

WIRING DIAGRAMS

1993 WIRING DIAGRAMS Chrysler Corp.

IDENTIFICATION

COMPONENT LOCATION MENU

COMPONENT LOCATIONS

Component	Location (Fig. No.)
A/C HEATER RADIATOR FAN SYSTEM	A-E 32-35 (9)
AIRBAG MODULE	A 23 (6)
ALTERNATOR	D 3 (1)
ANTI-LOCK BRAKE SYSTEM	B-E 20-23 (6)
ASHTRAY LIGHT	A 31 (8)
AUTO SHUTDOWN RELAY (3.0L)	A-B 11 (3)
AUTO SHUTDOWN RELAY (3.3L)	A-B 15 (4)
BACK-UP LIGHT RELAY	B 24 (7)
BACK-UP LIGHT SWITCH (M/T)	C 2 (1)
BATTERY	A 2 (1)
BODY COMPUTER	A-C 36 (10)
BRAKE WARNING INDICATOR SWITCH	A 16 (5)
BUS DIAGNOSTIC CONNECTOR	B 23 (6)
CIG LIGHTER	A 31 (8)
CLUTCH SWITCH (M/T)	B 16 (5)
COOLANT TEMPERATURE SENSORS	B 38 (10)
CRUISE CONTROL SYSTEM	C-E 24-27 (7)
DEFOG SWITCH	A 43 (11)
DIRECTIONAL (DIR) SWITCH	B 3 (1)
ELECTRONIC AUTOMATIC TRANSAXLE (EATX) CONTROL	A 24-27 (7)
ENGINE DIAGNOSTIC CONN (2.5L)	D 7 (2)
ENGINE DIAGNOSTIC CONN (3.0L)	C-D 11 (3)
ENGINE DIAGNOSTIC CONN (3.3L)	C-D 15 (4)
FLASHER RELAY	B 31 (8)
FOG LIGHT SWITCH	E 24 (7)
FUEL PUMP RELAY (2.5L)	A 7 (2)
FUEL PUMP RELAY (3.0L)	A 11 (3)
FUEL PUMP RELAY (3.3L)	A 15 (4)
FUEL TANK UNIT	E 42 (11)
FUSE LINK	A 2 (1)
FUSE LINKS	C-D 2-3 (1)
FUSE BLOCK	B-D 16-19 (5)
GLOVE BOX LIGHT	E 16 (5)
HAZARD SWITCH	B 28 (8)

1993 Dodge Grand Caravan ES

WIRING DIAGRAMS 1993 WIRING DIAGRAMS Chrysler Corp.

HEADER LIGHT SWITCH	C 38 (8)
HEADLIGHT DIMMER SWITCH	C 31 (8)
HEADLIGHT SWITCH	A-C 28 (8)
HI SPEED FAN RELAY	A 35 (9)
HORN RELAY	D-E 3 (1)
IGNITION OFF DRAW (IOD) CONNECTION	D 2 (1)
IGNITION SWITCH	A 17-18 (5)
ILLUMINATED ENTRY DOOR SWITCHES	C 38 (10)
INSTRUMENT CLUSTER	A 39 (10)
INTERIOR LIGHTS	C-E 36-39 (10)
KEY LIGHT SWITCH	D-E 39 (10)
LEFT FRONT DOOR AJAR SWITCH	B 38 (10)
LIFTGATE LIGHTS	D 39 (10)
LIFTGATE RELEASE SWITCH	B 43 (11)
LOW BEAM RELAY	C-D 31 (8)
NEUTRAL START/BACK-UP LIGHT SWITCH (A/T)	A-B 2 (1)
OIL PRESSURE SWITCH	B 38 (10)
OVERHEAD CONSOLE	D-E 36 (10)
PARK BRAKE SWITCH	A 16 (5)
PARK LIGHT RELAY	D 31 (8)
POWER DOOR LOCK SYSTEM	D-E 42-43 (11)
POWER MIRROR SYSTEM	A 40-42 (11)
POWER SEAT SYSTEM	B-C 40 (11)
POWER WINDOW SYSTEM	C-D 40-41 (11)
POWERTRAIN CONTROL MODULE (PCM) (2.5L)	A-D 4 (2)
POWERTRAIN CONTROL MODULE (PCM) (3.0L)	A-D 8 (3)
POWERTRAIN CONTROL MODULE (PCM) (3.3L)	A-D 12 (4)
PUMP MOTOR RELAY	E 23 (6)
PURGE SOLENOID (2.5L)	E-5 (2)
PURGE SOLENOID (3.0L)	D-E 8 (3)
PURGE SOLENOID (3.3L)	E 12 (4)
REAR WIPER/WASHER MODULE	E 40 (11)
REAR WIPER/WASHER SWITCH	E 31 (8)
RELAY BLOCK	D-E 17-18 (5)
RIGHT FRONT DOOR AJAR SWITCH	A 37 (10)
SAFETY SHUTDOWN MINI RELAY	C 27 (7)
SEAT BELT SWITCH	B 38 (10)
SPEAKER RELAY	E 19 (5)
STARTER RELAY	A 3 (1)
STOP LIGHT SWITCH	D 27 (7)
TRANS EMCC SOL	B 2 (1)
UNDERHOOD LIGHT SWITCH	E 3 (1)
VAN CONVERSION RELAY	D-E 27 (7)
VANITY LIGHT SWITCH	C 37 (10)

1993 Dodge Grand Caravan ES

WIRING DIAGRAMS 1993 WIRING DIAGRAMS Chrysler Corp.

VENT SWITCHES	D-E 36 (10)
WARNING INDICATOR CENTER	B 39 (10)
WASHER LOW FLUID LEVEL SENSOR	C-D 29 (8)
WASHER MOTOR	D 29 (8)
WIPER/WASHER SYSTEM	D-E 28-30 (8)
2 SPEED FAN CTRL MOTOR	A 33(9)
4WD VACUUM SOLENOID	B-C 25-26 (7)

GROUND LOCATIONS

Component	Location (Fig. No.)
GROUND A: (UPPER LEFT OF ENGINE)	A 1 (1)
GROUND B: (LEFT SIDE REAR OF ENGINE)	A 2 (1)
GROUND C: (LEFT FENDER SHIELD REAR OF BATTERY)	A 2 (1)
GROUND D: (RIGHT SIDE SHIELD)	B 2 (1)
GROUND E: (CENTER OF TRANSMISSION)	C 2 (1)
GROUND F: (LEFT SIDE OF CLOSURE PANEL FRONT OF BATTERY)	E 1-2 (1)
GROUND G: (TOP REAR OF ENGINE)	B 7 (2)
GROUND H: (TOP REAR OF ENGINE)	B 11 (3)
GROUND I: (LEFT SIDE OF ENGINE)	B 15 (4)
GROUND J: (RIGHT KICK PANEL)	A 19 (5)
GROUND K: (REAR OF I/P)	A 23 (6)
GROUND L: (LEFT KICK PANEL)	C 25 (7)
GROUND M: (LEFT REAR OF ENGINE)	B 35 (9)
GROUND N: (LEFT KICK PANEL)	E 33 (9)
GROUND O: (RIGHT OF LIGHT)	D 38 (10)
GROUND P: (FRONT HEADER)	E 37 (11)
GROUND Q: (THRU LIFTGATE PANEL)	B 42 (11)
GROUND R: (RIGHT REAR QTR PANEL)	B 42 (11)
GROUND S: (LEFT SIDE OF LIFTGATE)	C 42 (11)

WIRING DIAGRAMS

1993 Dodge Grand Caravan ES

WIRING DIAGRAMS 1993 WIRING DIAGRAMS Chrysler Corp.

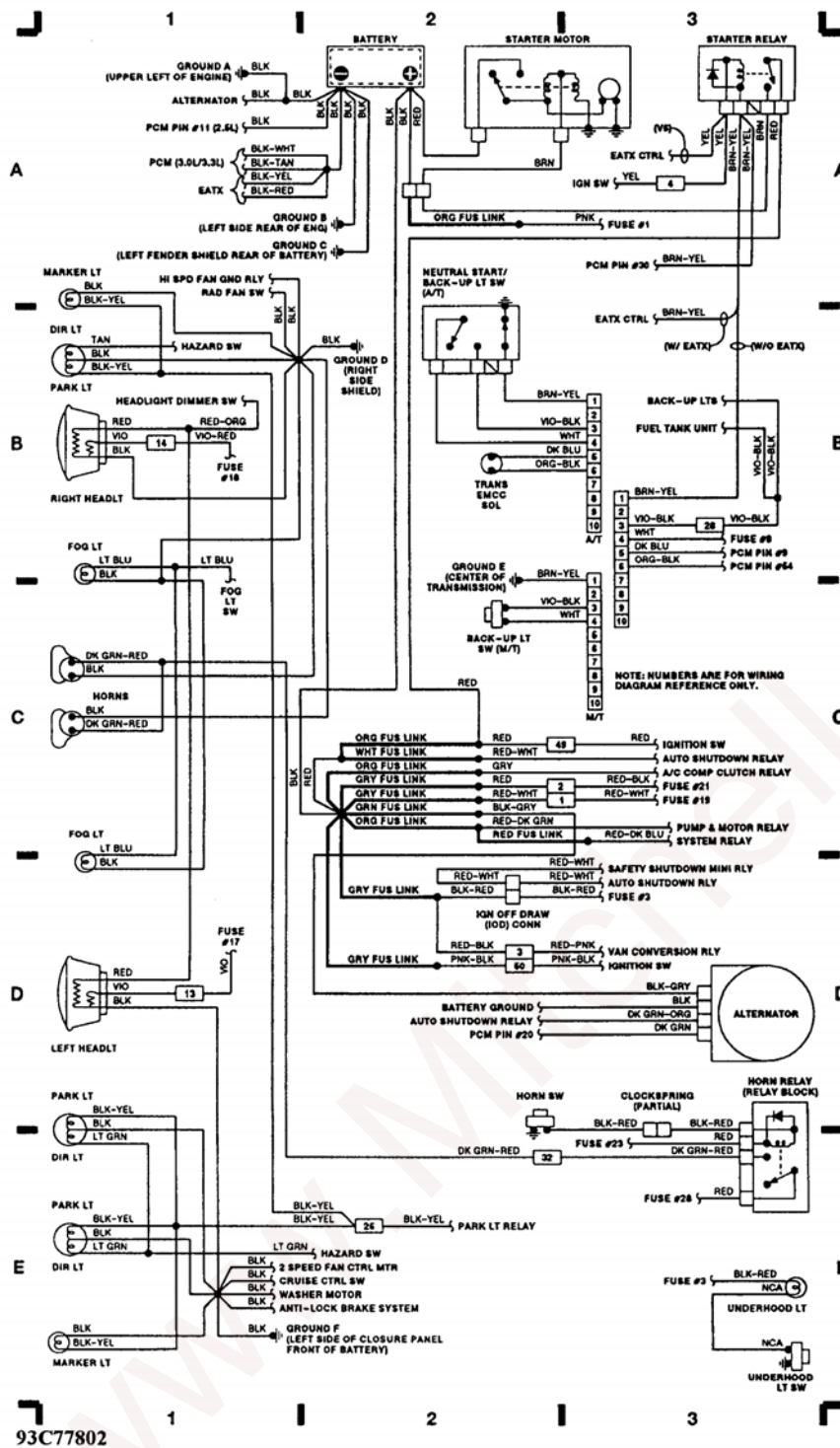

Fig. 1: Engine Compartment & Headlights (Grids 1-3)

1993 Dodge Grand Caravan ES

WIRING DIAGRAMS 1993 WIRING DIAGRAMS Chrysler Corp.

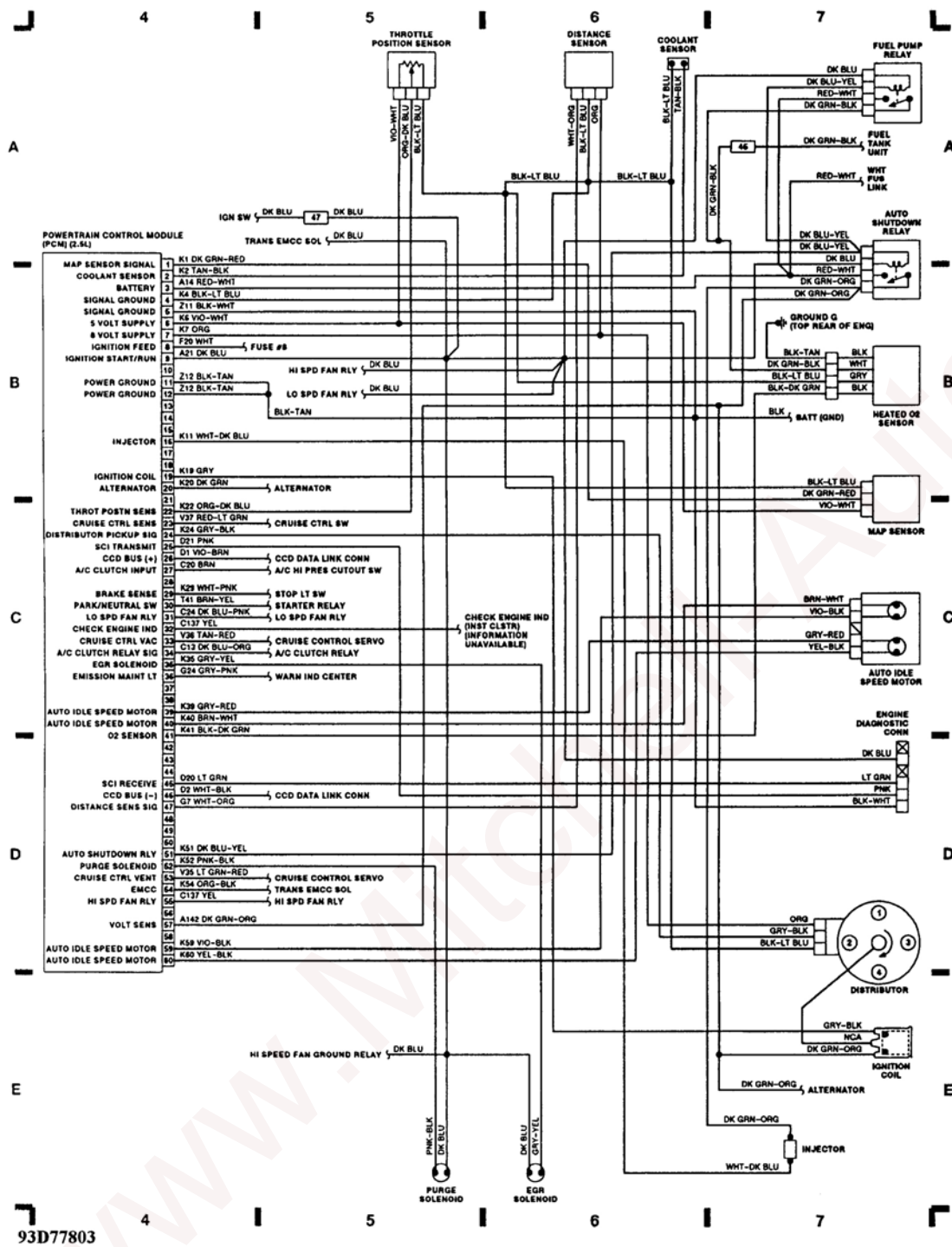
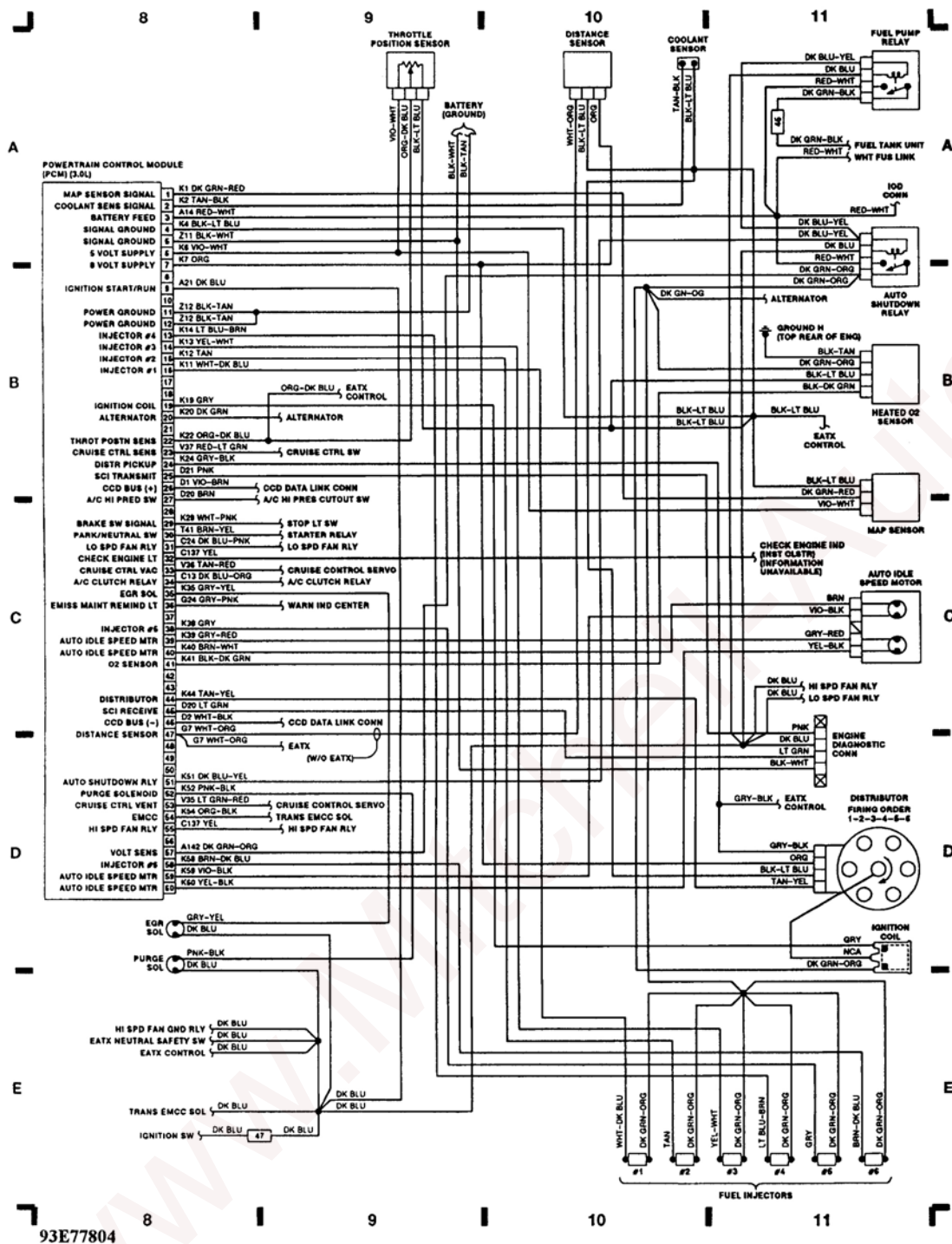

Fig. 2: Electronic Control Module (2.5L) (Grids 4-7)

1993 Dodge Grand Caravan ES

WIRING DIAGRAMS 1993 WIRING DIAGRAMS Chrysler Corp.



93E77804

Fig. 3: Electronic Control Module (3.0L) (Grids 8-11)

1993 Dodge Grand Caravan ES

WIRING DIAGRAMS 1993 WIRING DIAGRAMS Chrysler Corp.

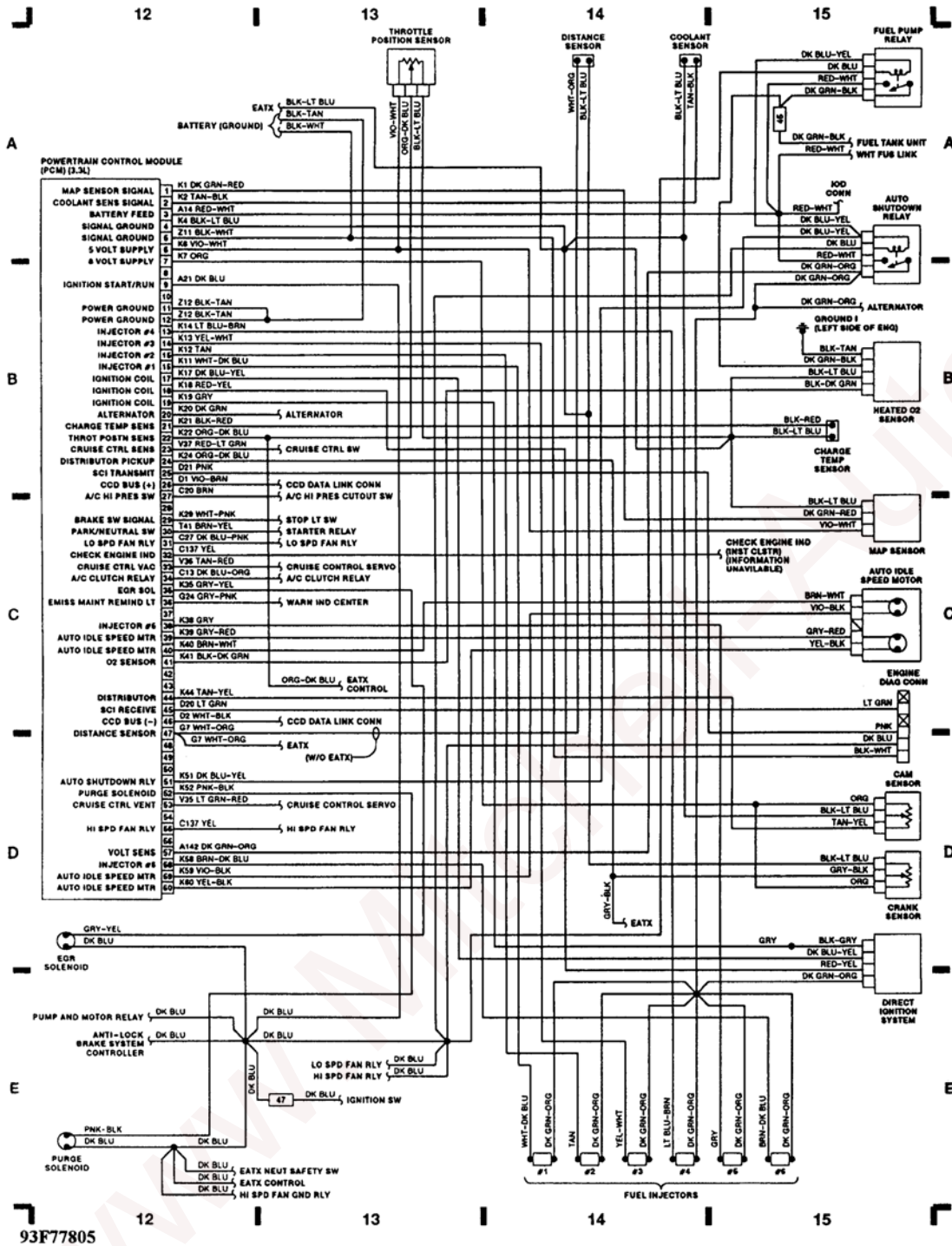

Fig. 4: Electronic Control Module (3.3L) (Grids 12-15)

1993 Dodge Grand Caravan ES

WIRING DIAGRAMS 1993 WIRING DIAGRAMS Chrysler Corp.

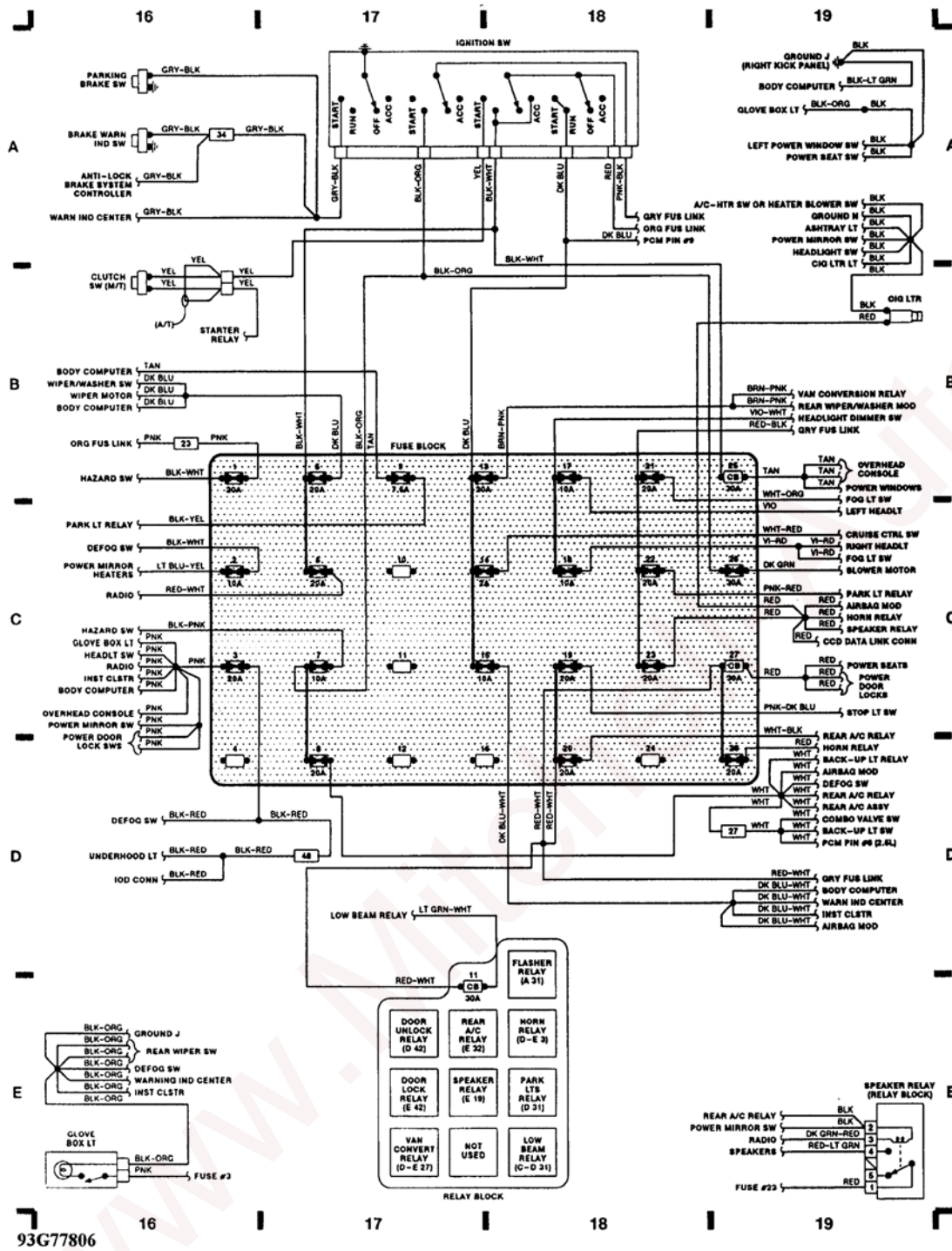

Fig. 5: Fuse Block (Grids 16-19)

1993 Dodge Grand Caravan ES

WIRING DIAGRAMS 1993 WIRING DIAGRAMS Chrysler Corp.

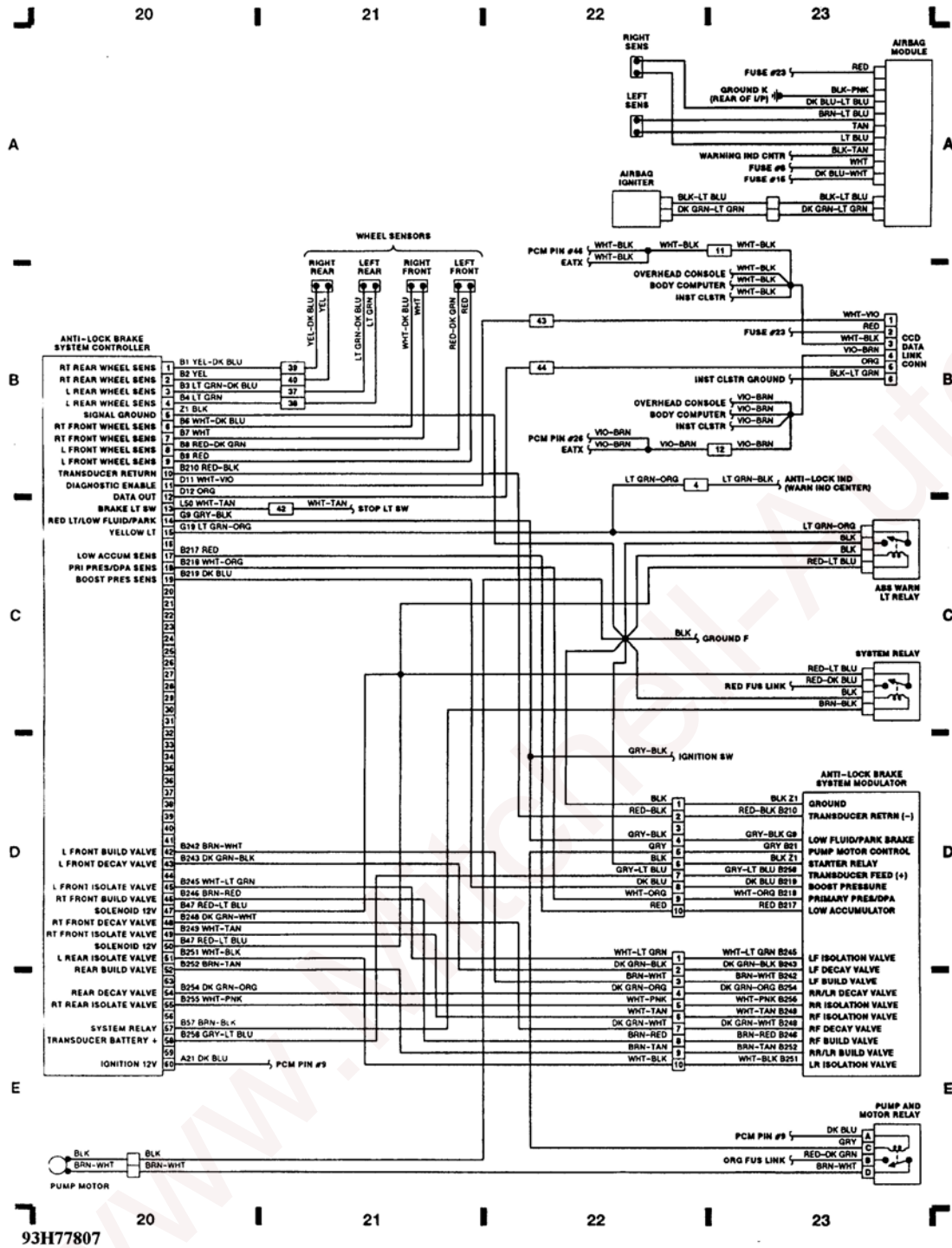

Fig. 6: Anti-Lock Brake System (Grids 20-23)

1993 Dodge Grand Caravan ES

WIRING DIAGRAMS 1993 WIRING DIAGRAMS Chrysler Corp.

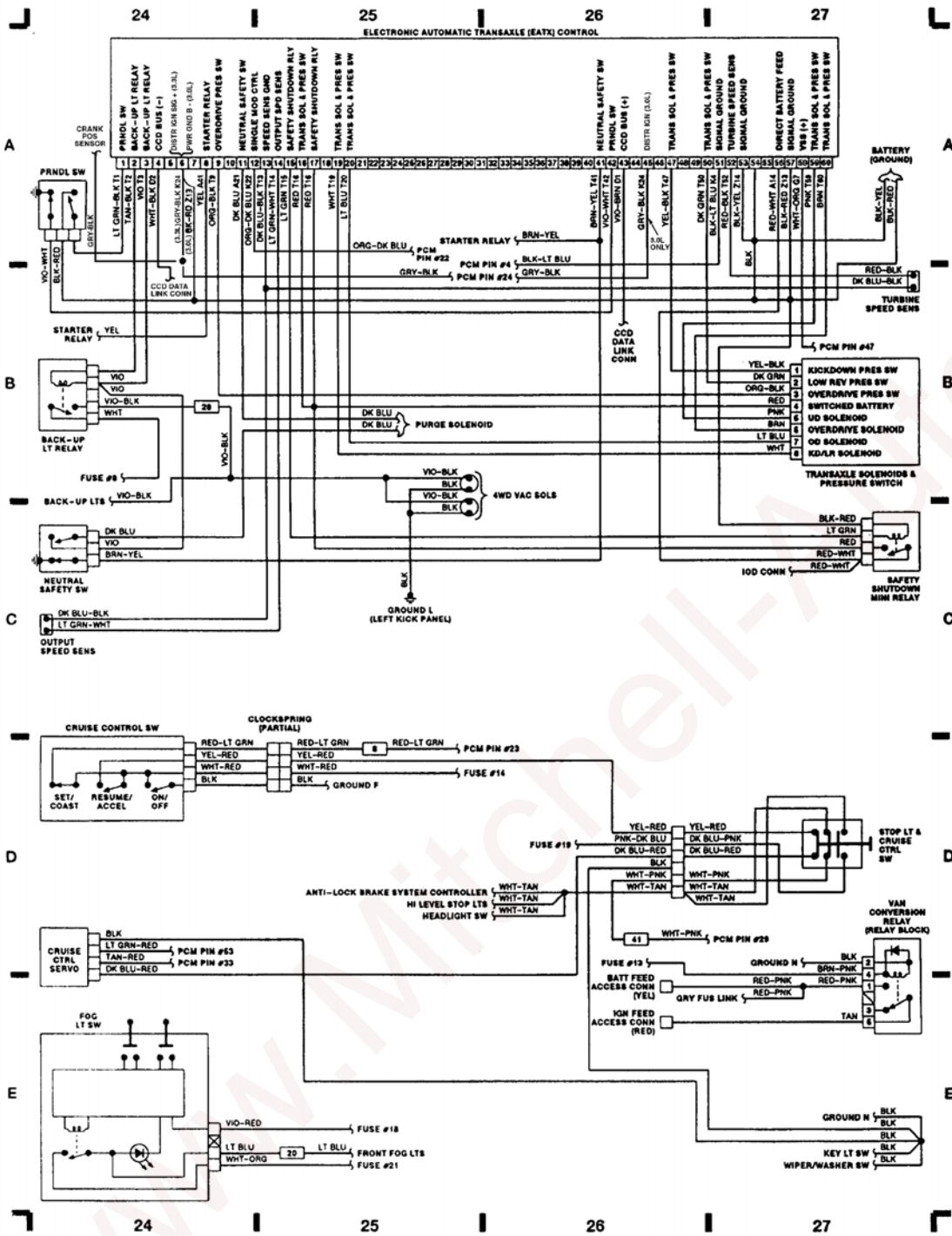

Fig. 7: EATX Control System & Cruise Control (Grids 24-27)

1993 Dodge Grand Caravan ES

WIRING DIAGRAMS 1993 WIRING DIAGRAMS Chrysler Corp.

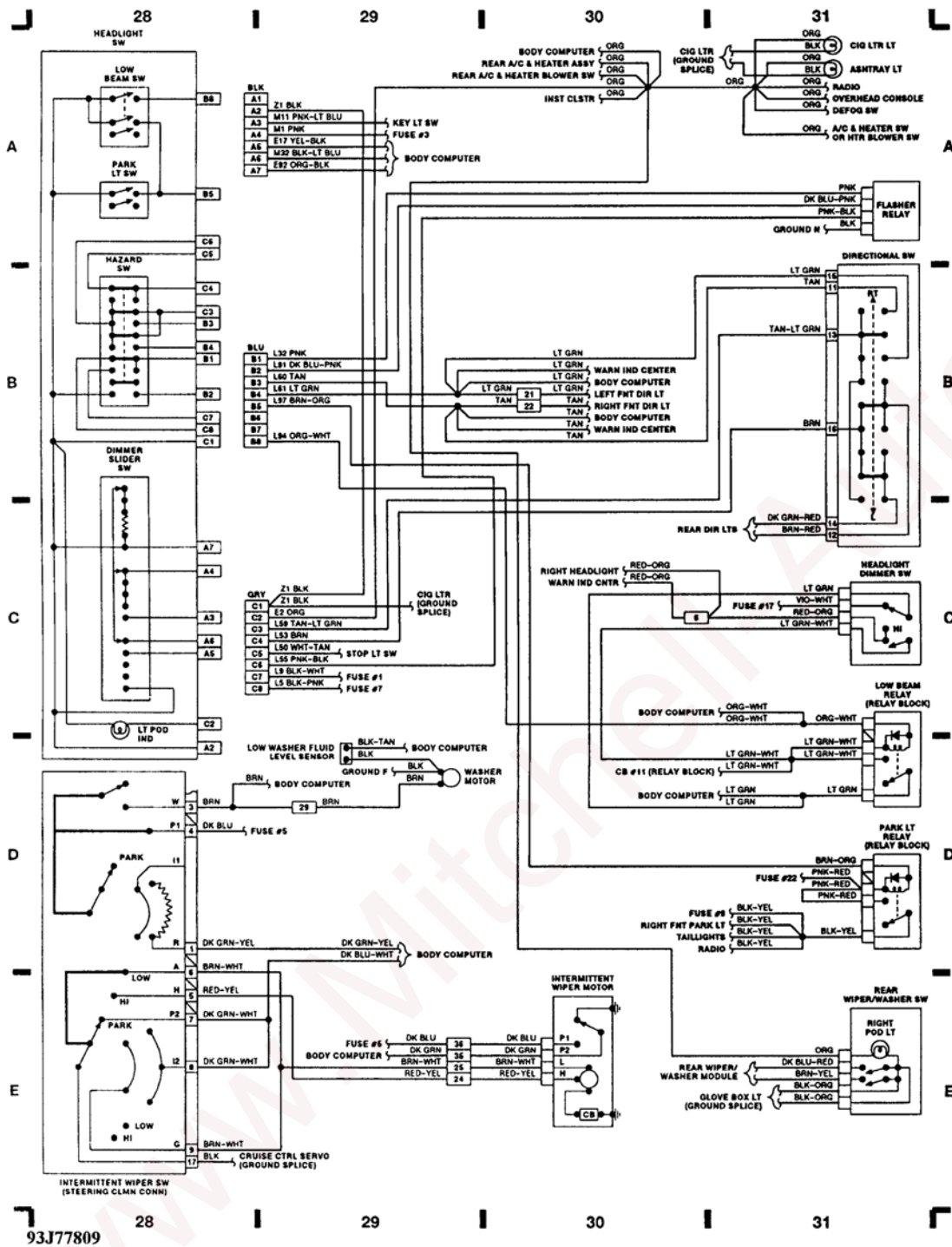

Fig. 8: Headlight Switch, Intermittent Wiper (Grids 28-31)

1993 Dodge Grand Caravan ES

WIRING DIAGRAMS 1993 WIRING DIAGRAMS Chrysler Corp.

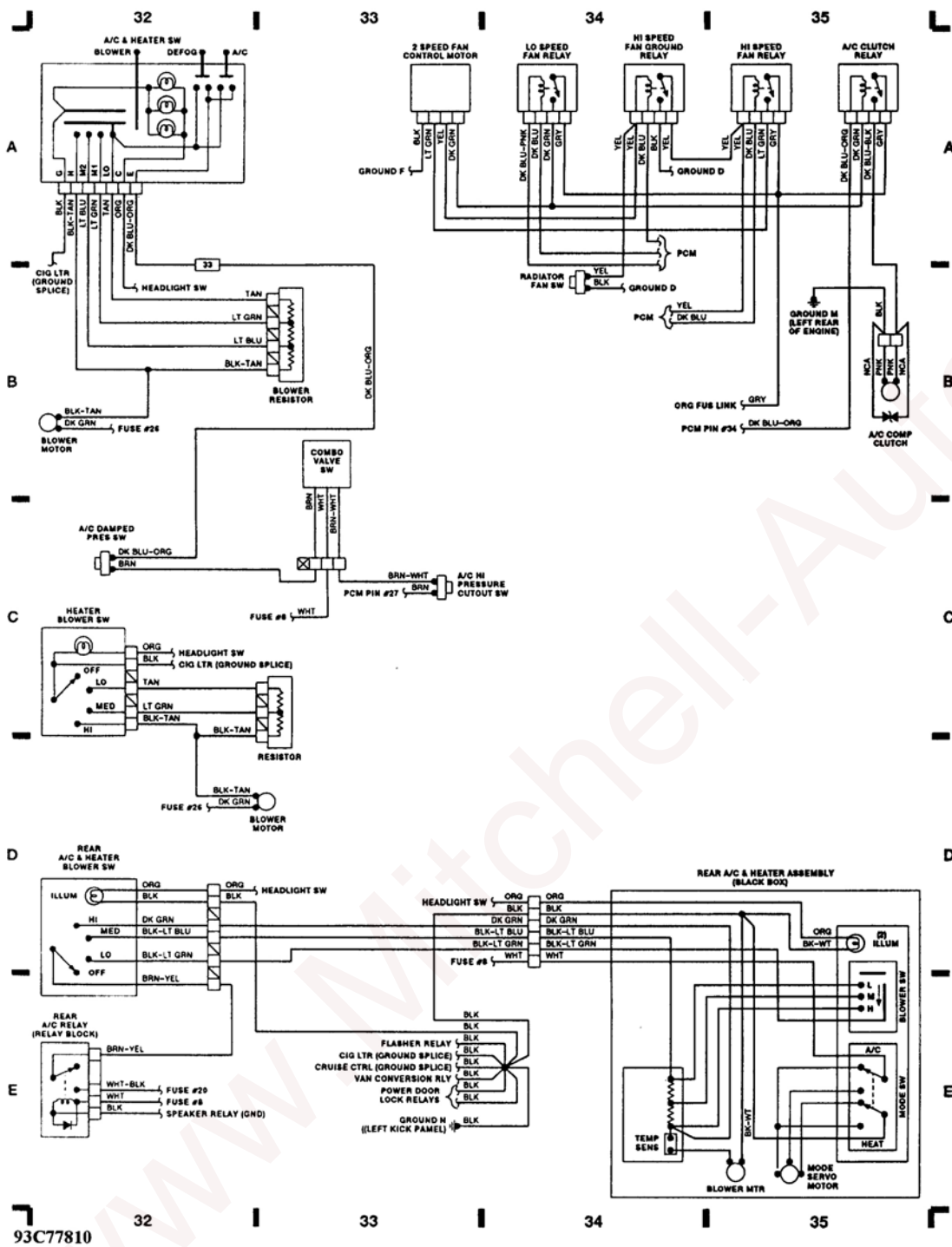

Fig. 9: Air Conditioning & Heater Switch (Grids 32-35)

1993 Dodge Grand Caravan ES

WIRING DIAGRAMS 1993 WIRING DIAGRAMS Chrysler Corp.

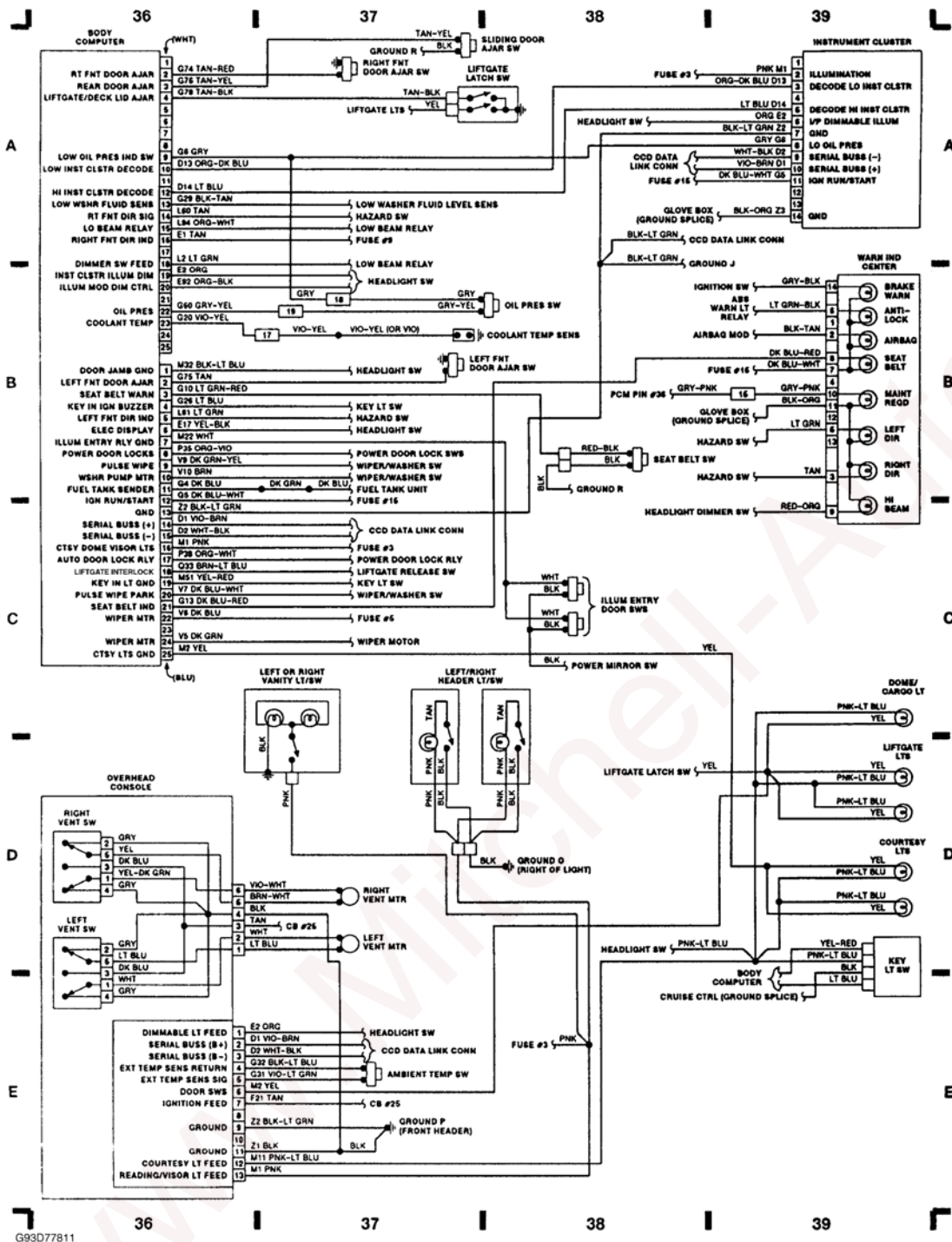

Fig. 10: Body Computer/Overhead Console/Inst. Clstr. (Grids 36-39)

1993 Dodge Grand Caravan ES

WIRING DIAGRAMS 1993 WIRING DIAGRAMS Chrysler Corp.

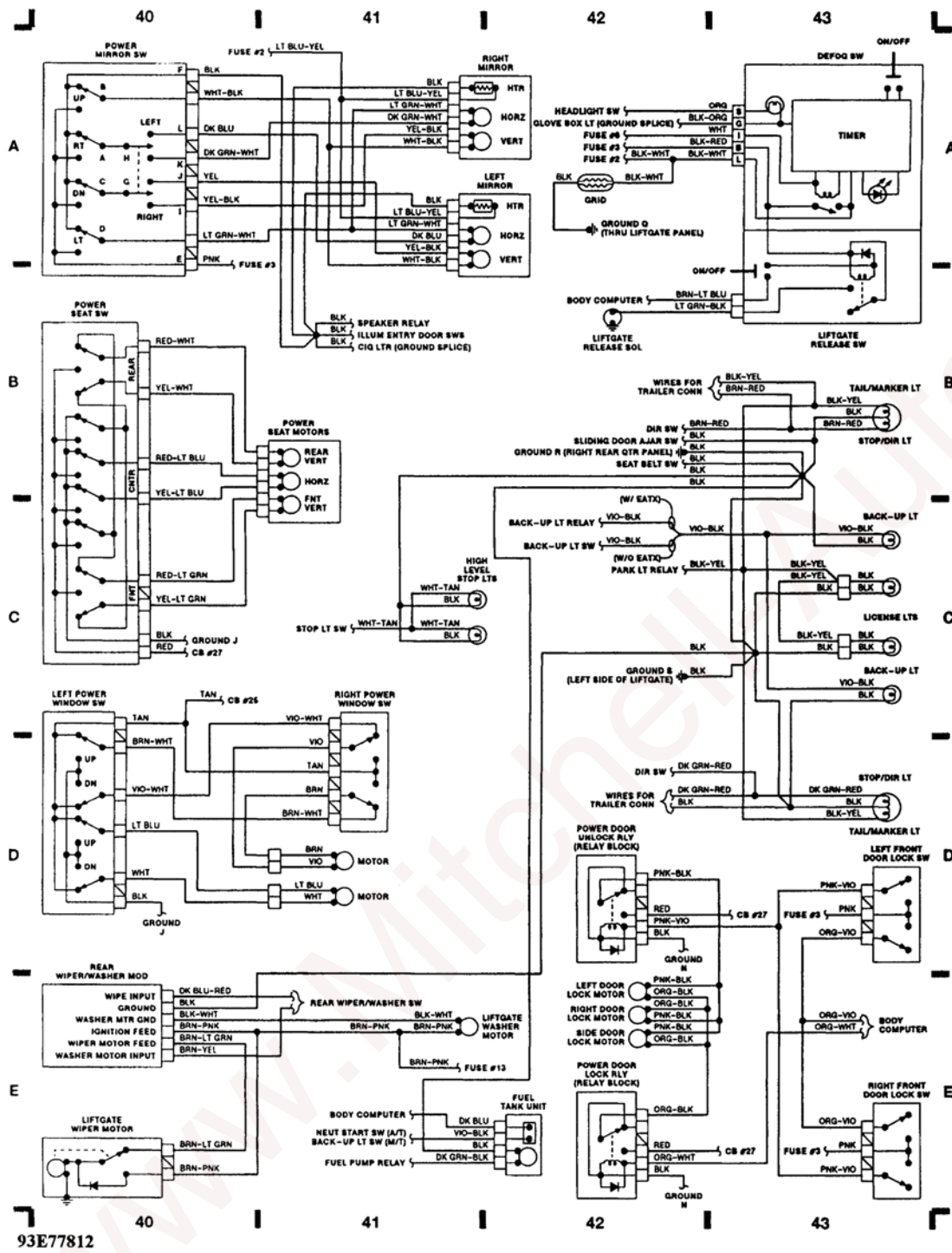

Fig. 11: Power Mirror, Window Switches & Taillights (Grids 40-43)