

# BYD F0 Owner's Manual

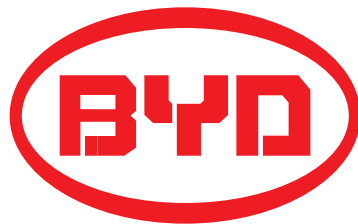

**BYD AUTO**

*Build Your Dreams*

BYD Auto Co., Ltd

## Preface

Thank you for choosing BYD F0. For better use and maintenance of BYD F0 AUTO, please do read this manual carefully.

BYD F0 adopts electrical fuel injection (EFI) engine. The wiring harness is complicated, so, without permission, please do NOT add electrical appliances such as anti-theft systems, central controlled door locks, power window, audio equipment, etc. to the AUTO; otherwise the failure caused by it will not be covered by the “Warranty” of BYD.

Please follow strictly the instructions where “Safety Friendly Tips” and “Auto Damage” are indicated in this manual to avoid the possibility of injuries or damages.

The notice types and their purposes are as follows

<b>Friendly Tips</b>
<b>Precautions to avoid vehicle damage or personal injury</b>

<b>Notice</b>
<b>Precautions to be followed to make maintenance easier</b>

The illustrations provided in this manual are for reference only.

BYD Auto Co., Ltd. reserves the right for revising technical characteristics and contents of this manual without prior notice.

Thank you for choosing BYD F0. Your valuables comments and proposals will be warmly welcomed.

### Safety Sign



The safety sign indicated by the figure above means “Do NOT do so” or “Do NOT let it happen”.

## Contents

Whole-vehicle Performance Parameters of BYD F0 .....	1
Chapter 1 Operation of Instruments and Controllers .....	4
1. Instrument Panel Exterior .....	4
2. Keys and doors .....	9
3. Seats, seat belts, steering wheel and rearview mirrors .....	20
4. Lighting, wipers and defrosters .....	36
5. Instrument and maintenance indicators .....	42
6. Ignition switch and parking brake .....	50
7. Auto audio system .....	53
8. Air conditioning system .....	59
9. Other devices .....	67
Chapter 2 Driving Tips .....	69
Chapter 3 Starting and Driving .....	76
Chapter 4 Emergency Handling .....	83
Chapter 5 Anti-corrosion and Automobile Exterior Maintenance .....	94
Chapter 6 Maintenance Knowledge .....	100
Chapter 7 Self-Maintenance .....	106
1. Preface .....	106
2. Engine and Chassis .....	112
3. Electrical appliance parts .....	120
Chapter 8 Specification of parts .....	131

## Whole-vehicle Performance Parameters of BYD F0

Product Model and Name		1.0MT	
Dimension	length	mm (millimeter)	3460
	width	mm (millimeter)	1618
	height	mm (millimeter)	1465
Wheelbase		mm (millimeter)	2340
Track	track front	mm (millimeter)	1420
	track rear	mm (millimeter)	1410
Curb Weight		kg (kilogram)	870
Gross Weight		kg (kilogram)	1245
Tire Size		165/60 R14	
Approach Angle		° (degree)	17
Departure Angle		° (degree)	31
Front Overhang		mm (millimeter)	655
Rear Overhang		mm (millimeter)	465
Passengers		5	
Maximum Speed		km/h (kilometer/hour)	≥151
Engine Model		BYD371QA	
Pattern		in-line 3-cylinder, 12-value, 4-stroke, water cooled, dual overhead cam, closed-loop electric fuel injection control	
Displacement		ml (milliliter)	998
Maximum Power Output kw/rpm (kilowatt/round per minute)		50/6000	
Maximum Gradeability		%	≥30
Constant-speed (90km/h)	One-hundred-kilometer	Fuel Economy	L/100km
		≤4.2	
Emission Standard		European III/European IV	

## Vehicle Identification of BYD F0

### Vehicle Identification Number

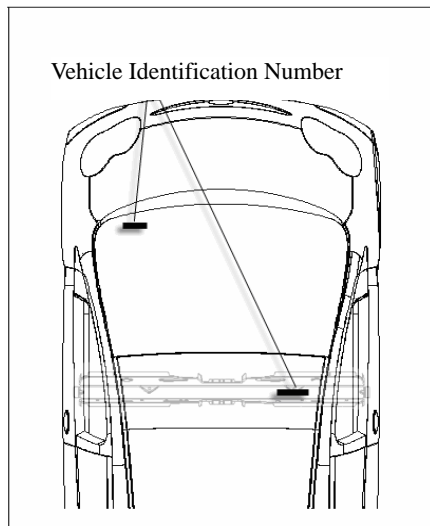

Two vehicle identification number labels are pasted respectively on the left upper side of the instrument panel and the floor beam under the co-driver seat as shown in the above figure.

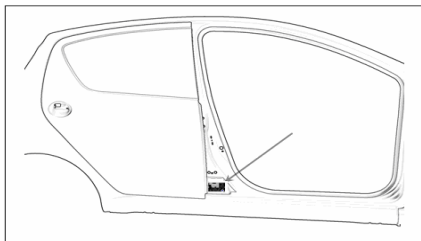

The vehicle identification number is also marked on the manufacturer nameplate at the bottom of the right side-frame B column as shown in the above figure.

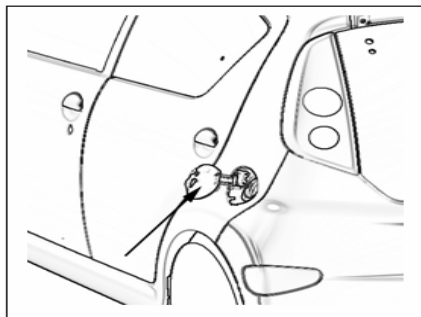
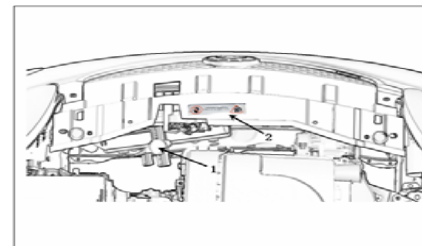
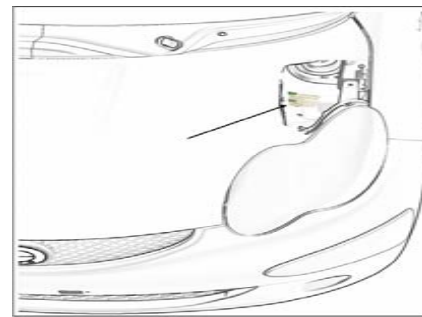

Figure above shows the fuel grade indication sign, which is pasted on the inner side of the fuel lid.



In the above figure, 1 is the indication sign of engine coolant, and 2 is the warning sign of cooling fan.



Warning sign of the air conditioning system

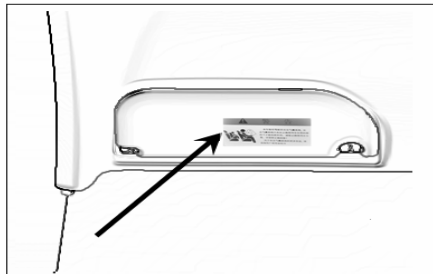

What the above figure shows is the warning sign of the air bag, which is pasted on the sun visor at the driver side.

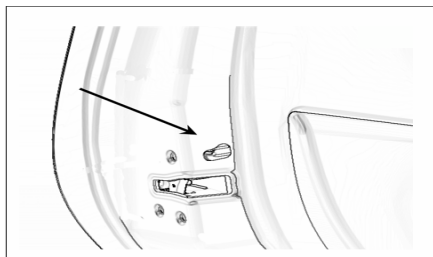

What the above figure shows is the indication sign of the child protection device, which is pasted above the child protection lock on the back of the rear vehicle door.

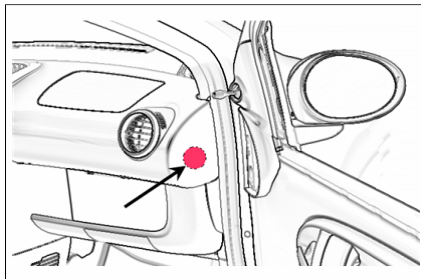

What the above figure shows is the warning sign of the co-driver air bag, which is pasted on the right side of the lower body of the instrument panel.

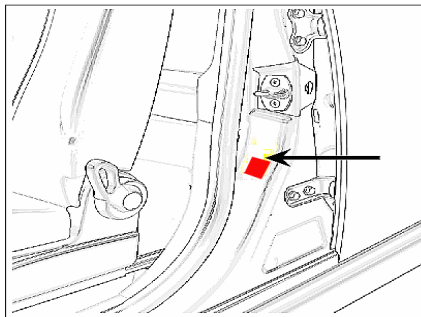

What the above figure shows is the

indication sign of the tire pressure, which is pasted on the lower part of the left front door lock.

## Engine Number

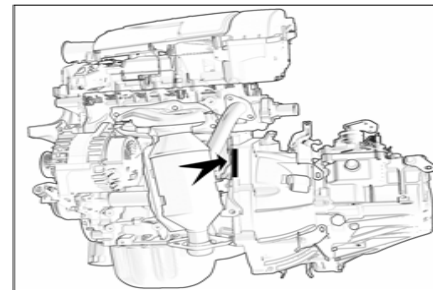

The engine number is marked on the engine cylinder body as the above figure shows.

**Section 1-1**

**Chapter 1 Operation of Instruments and Controllers**

**1. Instrument Panel Exterior**

Instrument Panel Exterior .....	5
Combined Meter Exterior .....	7
Indication signs on the combined meter.....	8

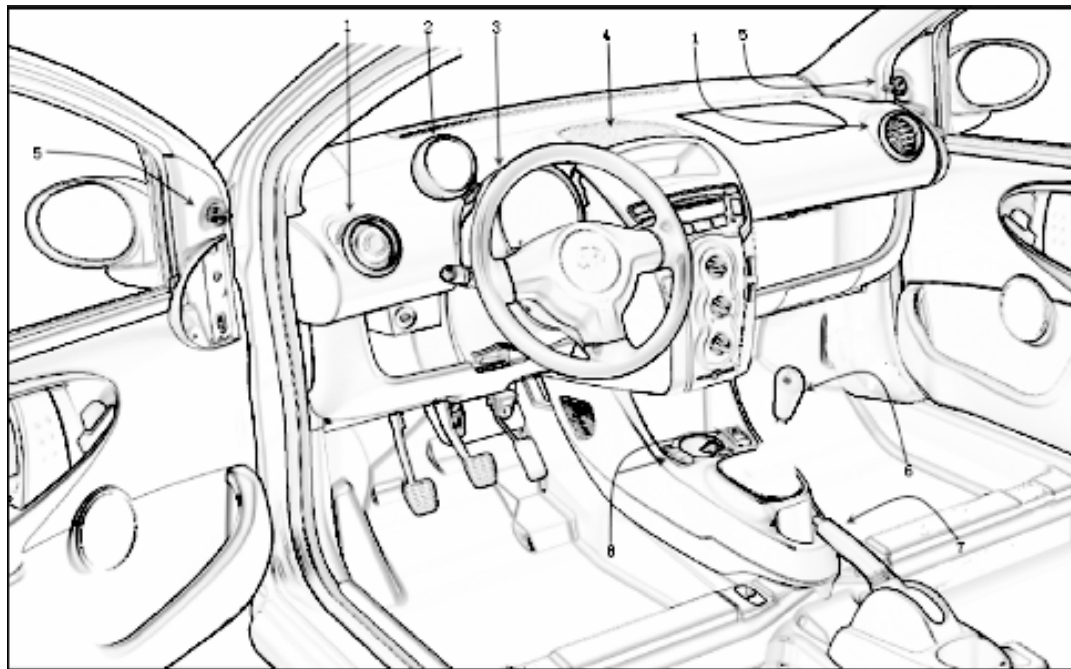
**Instrument Panel Exterior**

1. Side duct
2. Tachometer (if equipped)
3. Combined instrument
4. Central air outlet
5. Rearview mirror control handle
6. Manual transmission shift handle
7. Parking brake handgrip
8. Power window switch (if equipped)



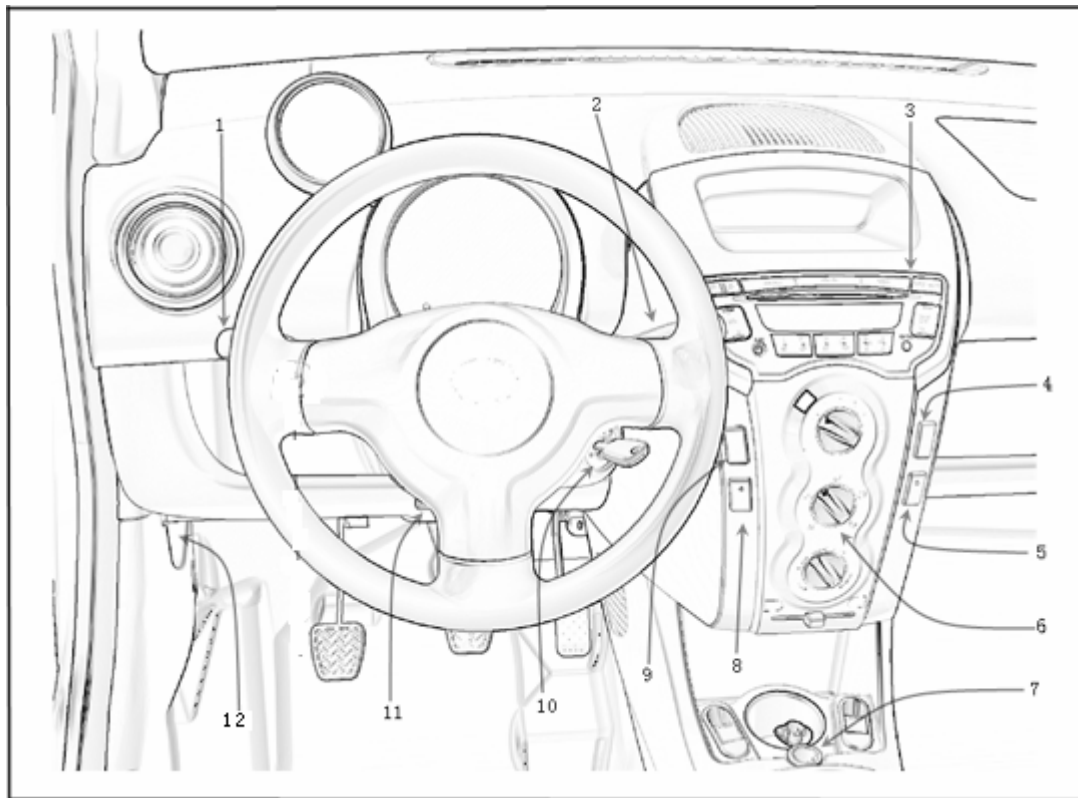





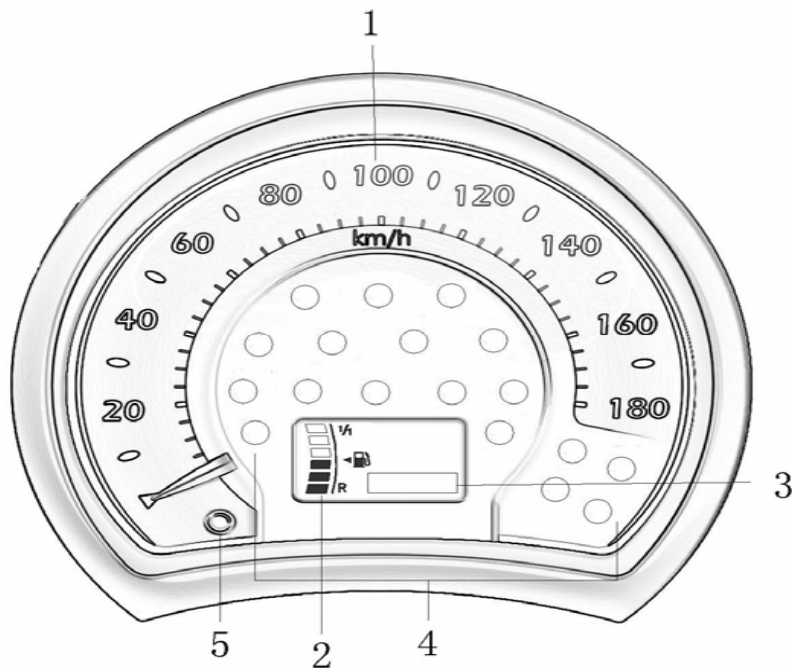











1. Switch of head lights, turn signal lights and rear fog lights
2. Switch of wipers and washers
3. Audio system
4. Switch of front fog lights (if equipped)
5. Rear defroster switch (if equipped)
6. Air conditioner control panel
7. Cigar lighter (if equipped)
8. A/C switch
9. Emergency alarm light
10. Ignition switch
11. Steering wheel position adjustment mechanism
12. Engine hood opening handle

## Combined Meter Exterior



1. Speedometer
2. Fuel gauge
3. Odometer
4. Maintenance indicator
5. Short trip reset button

### Indication signs on the combined meter

	braking system warning light *		ABS system warning light *
	seat belt indicator *		SRS warning light *
	battery discharge indicator *		position indicator
	low engine oil pressure indicator *		high beam indicator
	engine fault indicator *		turn indication and danger warning light
	low fuel level reminding light *		front fog light indicator
	low coolant temperature warning light *		rear fog light indicator
	high coolant temperature warning light*		door-open warning light

Items marked with “\*” are maintenance indicators. Refer to “Maintenance indicators and warning buzzers” in Section 1-5 for details.

**Section 1-2****Operation of Instruments and Controllers****2. Keys and doors**

Keys .....	10
Side door .....	11
Remote controller (if equipped) .....	12
Rear side door windows .....	15
Rear back door .....	16
Engine hood .....	16
Fuel tank cap .....	18

## Keys

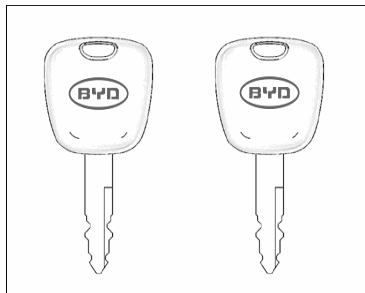

**Main and auxiliary keys for autos without central door lock control systems**

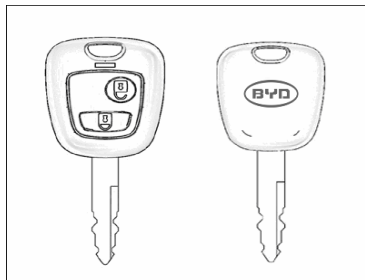

**Main and auxiliary keys for autos with central door lock control systems**

Friendly Tips: Please carry a spare key with you for use when you have left the key locked in the auto.



- 1) Do not bend the key handle.
- 2) Do not knock at other objects with the key.
- 3) Do not place the key where the temperature is high, e.g. on the instrument panel or the engine hood under direction solar irradiation.
- 4) Do not dip the key into water or wash it in ultrasonic cleaning solution.

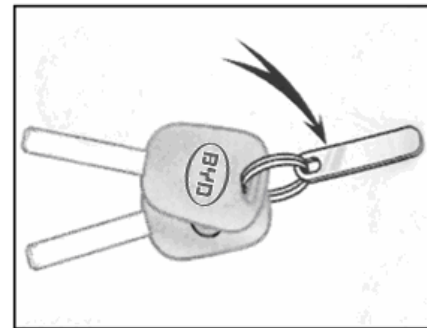

### Key number plate

The key number is indicated on the key number plate. Put the key number plate in a safety place. Do not put in the car. We suggest you write the key number down and save it in a safety place.

## Side door

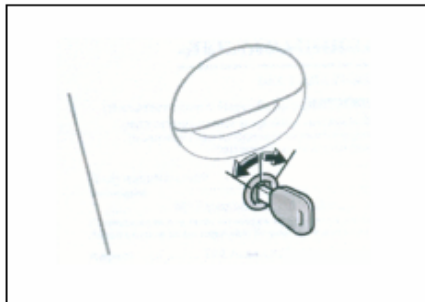
**Unlocking and locking with the key**

Insert the key into the key hole and turn it.

Unlock: Turn the key rightward.

Lock: Turn the key leftward.

When the auto is equipped with central door lock control systems, the side doors and the drive-side door will be simultaneously locked and unlocked.

## Unlocking and locking of the lock knob

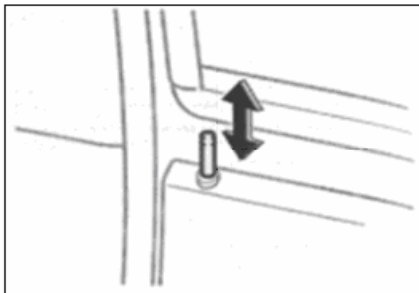

Unlock: Pull the lock knob upward.

Lock: Press the lock knob downward.

Friendly Tips: To lock the auto doors from the side side, set the lock knob at the locking position before closing the front side door, and then lift the side outer pull handle and close the door. Take care not to lock the key in the car.

## Rear-door child protection lock

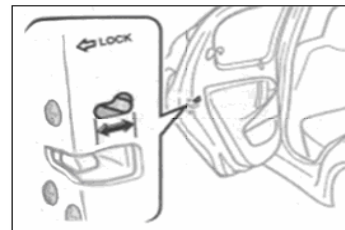

**Shift the lock lever to the “LOCK” position as the above figure**

When the child protection lock is locked up, the rear door cannot be opened with the inner catch handle (can be opened with the outer pull handle). We suggest you use this function as long as there is a child in the car.

**Friendly Tips**

**Before actuating the auto, especially when there is any child in the car, please make sure the door is closed and locked. Correct seat belt use and door lockup is helpful to prevent the driver and passengers from being thrown out in case of accidents and prevent unexpected opening of the doors.**

### Remote controller (if equipped)

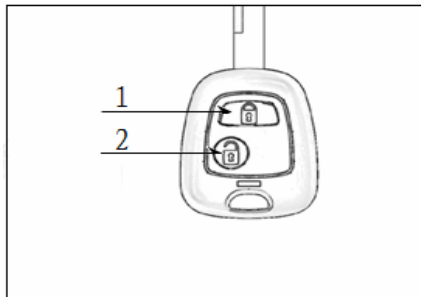

1、 “” “locking button

2、 “” “unlocking button

For manipulating any button, press it down slowly and correctly. For locking, the turn lights will flash once; for unlocking, the turn lights will flash twice.

Follow the following instructions for avoidance of remote controller damage:

- Do not place the remote controller where the temperature is possibly high, e.g. on the instrument panel.
- Do not disassemble it without permission.

- Do not knock in violently against other objects or throw it on the ground.
- Avoid putting it in water.

If the remote controller does not work, please check:

- Whether there is any wireless radio station or airport radio transmitter nearby that may interfere with the normal operation of the transmitter.
- Whether the battery power has run out. Check the battery in the transmitter. For battery replacement, please refer to “remote controller battery replacement” in this section.

If the problem cannot be solved, please contact authorized service stations of BYD. If the remote controller is lost, please contact immediately authorized service stations of BYD for avoidance of burglary accidents.

### Door lockup and opening

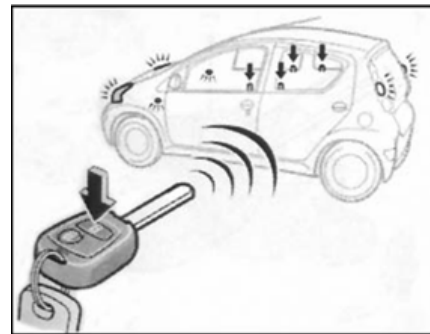

#### Door lockup

**Lock:** Press “”. All side door lock motors simultaneously execute locking action once and the turn signal lights flash once.

Check whether all doors are truly closed.

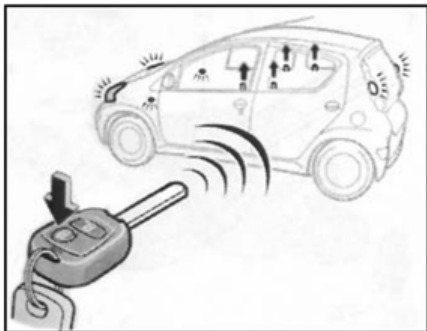

- The remote controller won't work.
- The operation range of remote control becomes very narrow.

#### Battery replacement

CR2016 lithium batteries or equivalent should be used for replacement. It is suggested to have the battery replaced in a BYD authorized service station.

#### Door opening

Open: Press “”. All side door lock motors simultaneously execute unlocking action once and the turn signal lights flash twice.

The action will be executed once if the button is pressed once. Continual press of the button won't repeat the action. To execute the action once again, release the button and press it again.

The following phenomena suggest that power in the battery of the remote controller has possibly run out and battery replacement is needed (see “Battery replacement” in this page):

#### Notice

- ◆ Do not have relevant part lost in battery replacement.
- ◆ Only a battery of the specified model or suggested by the BYD authorized service station can be used for replacement.
- ◆ Used batteries should be disposed according to local laws and regulations.
- ◆ Take care not to let children swallow replaced remote controller batteries or parts.

Replace the remote controller battery according to the following procedures:

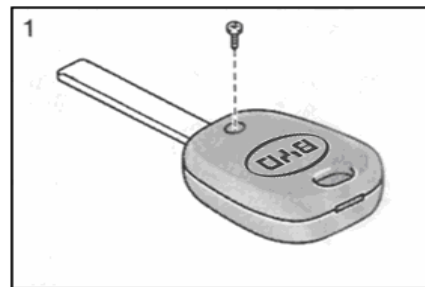

1. Screw off the screw.

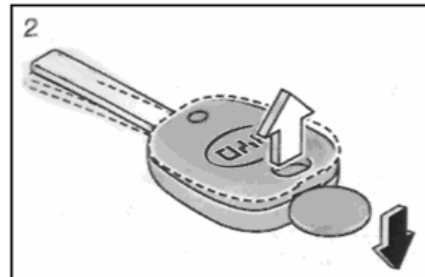

2. Open the remote controller with a coin or a similar tool.



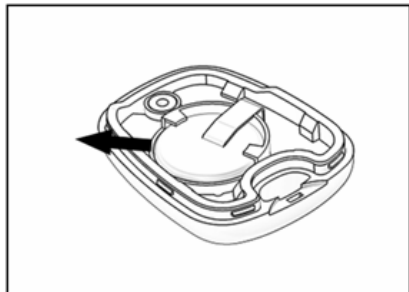

3. Take the used battery.

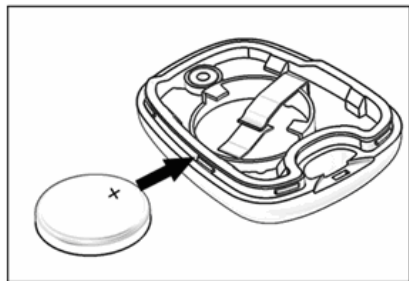

4. Place a new battery in with the anode (+) facing upward.  
5. Close the remote controller firm and screw up the screw.

#### Notice

- ◆ Make sure the anode and cathode of the remote controller battery are correctly positioned.
- ◆ Do not replace the battery with wet hands; water may lead to unexpected rustiness.
- ◆ Do not touch or move any part in the remote controller; otherwise, correct operation may be affected.
- ◆ When positioning a new battery in the remote controller, pay attention not to bend the electrodes and remove dust and oil in the remote controller box.

After battery replacement, check whether the remote controller can work normally. If it still cannot work, please contact authorized service stations of BYD.

#### Notice

- ◆ Without permission, do not alter the emission frequency, increase the emission power (by including but not limited to adding emission frequency amplifiers), equip external antennas or use other emission antennas.
- ◆ Use of the remote controller should not produce any harmful interference to any legal wireless communication services; stop use of the remote controller immediately if any interference is found and do not use it until measures have been taken and the interference has been eliminated.
- ◆ Do not use the remote controller near aircrafts or airports.

## Electric door windows (if equipped)

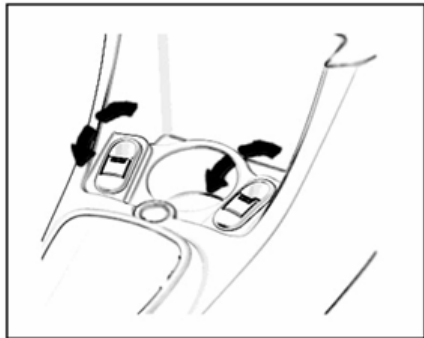

The front electric window switches at the left/right side of the auxiliary instrument panel can respectively control the left/right front door windows.

Operation of the front door window:

The ignition key should be in "II" position.

Open: Press down the switch lightly.

Close: Pull upward the switch lightly.

## Warning

For avoiding damage to people, please read the following instructions:

- Before closing the power windows, make sure there is no man around the window and make sure heads, hands and other parts of passengers are in the car. If necks, heads or hands of passengers are caught by the closed window, severe damage may be caused. Therefore, operation safety should be ensured in closing power windows.

- Do not let children manipulate the power window switches without attendance; otherwise, they may be caught by the windows.

- Make sure the ignition key is taken away or is in "0" position when leaving the car.

## Rear side door windows

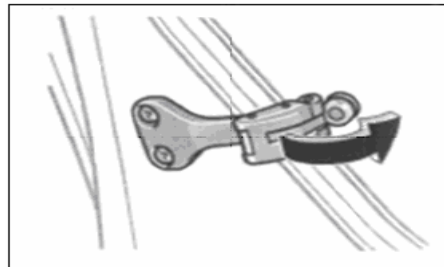

Open the side door glass as shown in the above figure.

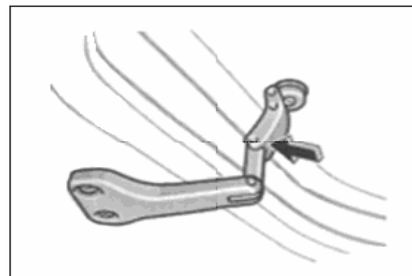

Push to open the side door glass side-opening mechanism as shown in the above figure.

## Rear back door

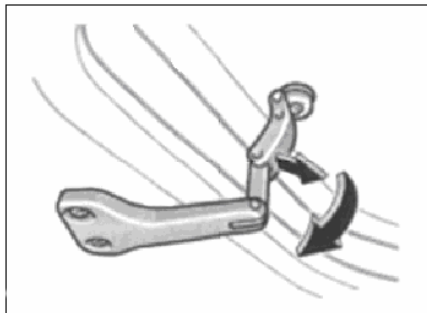

Close the side door glass as shown in the above figure.

Friendly Tips
---------------

- |  |
|--|
| <ul style="list-style-type: none"> <li>● The rear side window should be pushed open completely; otherwise, the window side-opening mechanism will automatically return.</li> <li>● Be careful when closing rear side windows for hand-caught avoidance.</li> </ul> |
|--|

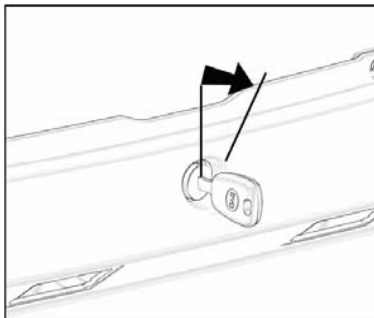

Unlock: Insert the key into the key hole and turn it clockwise.

When closing the rear back door, please check whether it is effectively closed. For considerations of baggage loading, please refer to “Considerations of baggage loading” in Section 2.

Friendly Tips
---------------

- |   |
|---|
| <ul style="list-style-type: none"> <li>● In driving, make sure the rear back door is closed. This can prevent the baggage from being thrown out and exhaust from entering the compartment.</li> </ul> |
|---|

## Engine hood

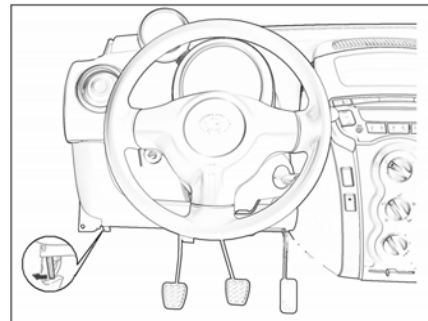

Open the engine hood:

1. Draw up the engine hood opening handle. The engine hood will spring up a little.

Friendly Tips
---------------

<p>Before driving, make sure the engine hood is closed and locked firm. Otherwise, in driving, the engine hood may open suddenly and cause accidents.</p>
---

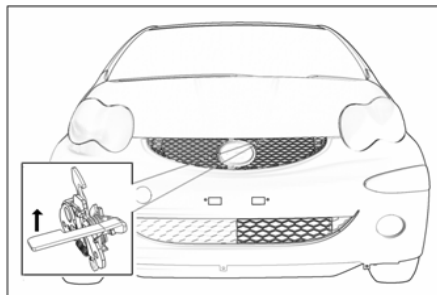

2. Stand in front of the car, draw upward the assistant handle of the engine hood lock and lift the engine hood.

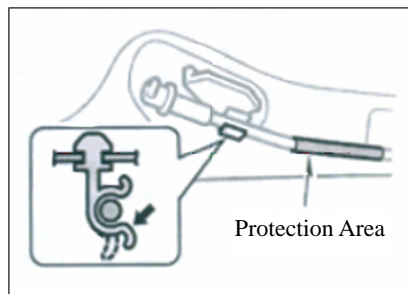

As shown in the above figure, hold the protection area and remove the engine hood bracket from its seat.

#### Notice

- ◆ Hold the protection area to avoid burning.

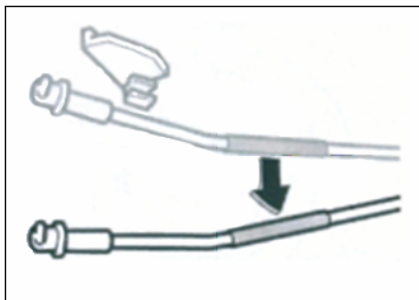

Move the engine hood bracket as shown in the above figure.

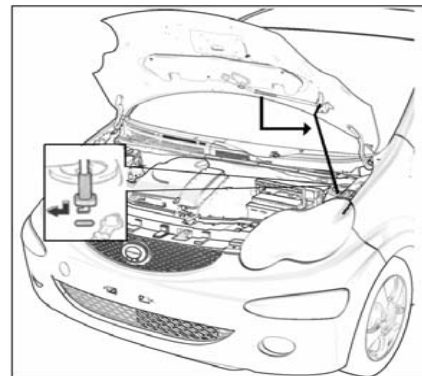

3. Insert the engine hood bracket in the groove to keep the engine hood open.

Before closing the engine hood, check whether there is any tool or rag left in the engine hood. Place the engine hood bracket back into its seat and then put down the engine hood and check whether it is locked up. If necessary, press its front edge to lock it up.

### Friendly Tips

- After the engine hood bracket is inserted into the groove, make sure it firmly supports the engine hood; otherwise, the engine hood may fall down and hurt you.

### Fuel tank cap

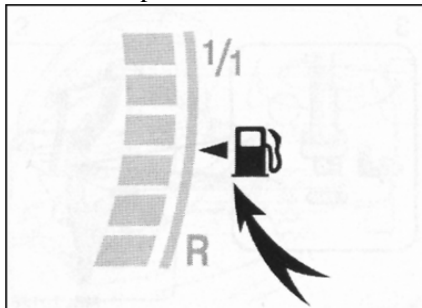

This figure indicates that the fuel filler port is on the left side of the car.

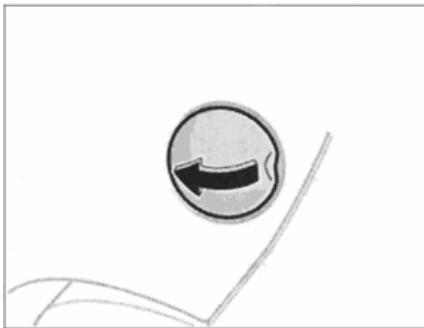

1. Open the fuel filler port.

In fuel injection, the engine should be kept turned off.

### Friendly Tips

- Do not smoke in fuel injection. Sparks or flames will lead to fires.

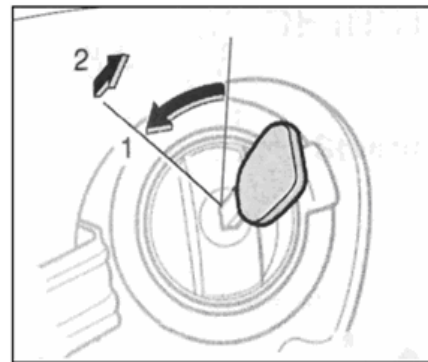

2. For taking off the filler port lid, turn the key anti-clockwise for 90° to position 1 in the above figure and, after a few seconds, take the key and the fuel tank cap at the same time.

If the fuel tank cap still cannot be taken off, please repeat the above operation. When the fuel tank cap is taken out, a slight noise can be heard. It's normal.

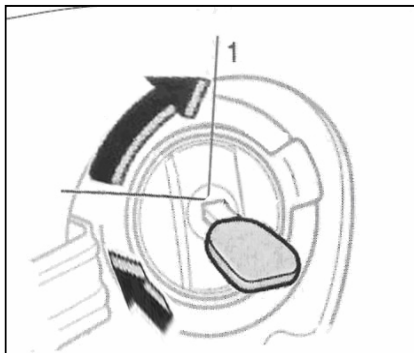

3. For mounting the fuel tank cap, insert the key with the fuel tank cap into the fuel hose, turn the key clockwise for 90° to position 1 in the above figure and then take the key out.

#### Friendly Tips

- For avoiding fuel outflow in accidents, make sure the fuel tank cap is screwed firm.
- Only genuine and original fuel tank caps for BYD F0 autos can be used for the replacement purpose. They can adjust the pressure of the fuel tank.
- For opening the fuel tank, the cap should not be taken off suddenly. In hot weather, if the fuel tank cap is taken off suddenly, pressurized fuel may spurt out from the filling port and cause human damage.

## **Section 1-3**

### **Operation of Instruments and Controllers**

#### **3. Seats, seat belts, steering wheel and rearview mirrors**

Seats .....	21
Front seats .....	21
Integrated foldable rear seat .....	22
Head protection device.....	22
Seat belts .....	22
Airbag for the driver and the front passenger .....	25
Outer rearview mirrors.....	34
Inner rearview mirror.....	35

## Seats

When the automobile is driving, all passengers should adjust the seat backs straightly upward, lean on the seat backs on the back and use the seat belts correctly.

### Friendly Tips

- The auto should not be actuated until all passengers have been seated down well. Do not sit on the upper back part of a folded seat or on trunk or baggage. In emergency braking or collisions, passengers whole have sat straight or had the seat belts buckled up may be seriously injured.
- In driving, do not let passengers stand up or move among seats; otherwise, they may be seriously injured in emergency braking or collisions.

## Front seats

### Considerations of seat adjustment

Adjust the driver seat to include the pedals, the steering wheel and the instrument panel controller into the easy-control range of the controller.

### Friendly Tips

- Do not adjust the seat when the car is driving, since sudden movement of the seat may lead to auto control failure.
- In seat adjustment, take care to avoid collision between the seat and passengers or baggage.
- After the seat is adjustment, make sure it is locked up at its position.
- After seat adjustment, lean backward to see whether the seat back is locked up at its position.
- Do not place things under the seat; this may affect the seat lockup mechanism and lead to some movement of the seat, causing auto control failure.
- In seat adjustment, do not put your hand under the seat or near moving parts; otherwise, your hand or fingers may be injured.

### Front seat adjustment

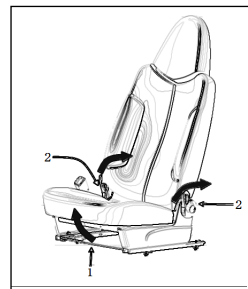

Front seat with double angel adjustment rod (Optional)



Front seat with single angel adjustment rod (Optional)

**1. Seat front-rear position adjustment rod**  
Hold the middle of rod 1 and pull it upward, move the seat frontward and backward to the desired position and then release the rod.

**2. Seat back angle adjustment rod**  
Hold rod 2 and pull it backward, slope the back to the desired angle and then release the rod.



### Friendly Tips

- Seat belts can provide the maximum protection in collision accidents if the driver and passengers sit straight and lean on the seat backs. If you lean on the seat back obliquely, the seat belt part for the waist may slide over your hip and directly exerts pressure on your belly. In front-collision accidents, over obliquity of the seat may increase the risk of human injuries.

### Rear seats

#### Integrated fixed rear seat

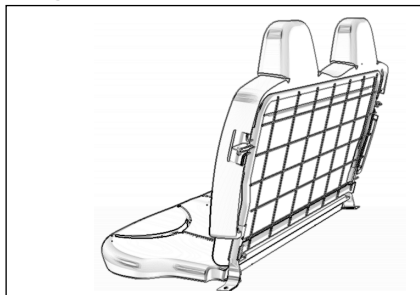

#### Integrated foldable rear seat (Optional)

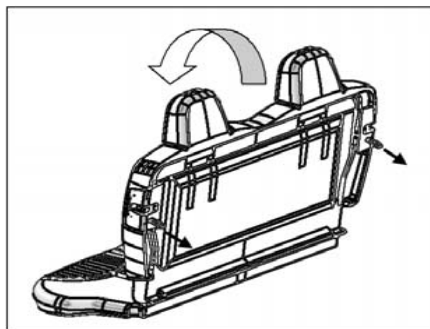

Pull the right and left sides of the rear seat back simultaneously backward. The left and right unlocking belts will unlock the seat back and fold it downward. The trunk will be expanded to the backs of the front seats. For considerations of baggage loading, refer to “Considerations of baggage loading” in Section 2.

### Friendly Tips

**When returning the seat back to the upright position, to prevent human injuries in accidents or emergency braking, the following preventive measures should be taken:**  
**Pull and push the seat back to make sure it is firmly locked up.**  
**Make sure the seat belt is not bent or caught by the seat back and arrange it in the correct position.**

### Head protection device

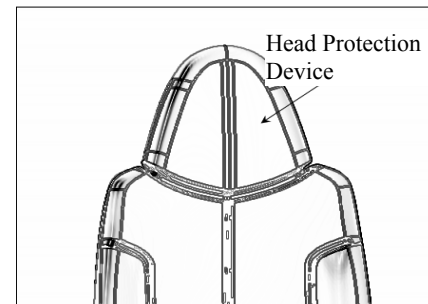

For safety and comfort, the seats are equipped with head protection devices

### Seat belts

#### Consideration for use of seat belts:

BYD strongly require that the driver and passenger in the vehicle wear seat belts at any time to reduce the possibility of injuries in accidents.

Seat belts equipped on the vehicle are designed for adults and should be applied to children with caution.

It is suggested to seat children in the rear seat with child chairs and fasten the seat belt for protection. According to accident statistics, it is safer to correctly protect children in the rear seat than in the front seat.

If a child has to be arranged in the front seat, it is necessary to use a child seat and fasten the seat belt correctly; otherwise, in accidents, the airbag will deploy quickly and cause severe injury to the child.

Arranged in the front seat or the rear seat, children should not be allowed to stand or kneel. In emergency braking or crashes, unprotected children may be seriously injured. Similarly, do not seat children on your legs; as such, they won't be fully protected.

#### Friendly Tips

**When the vehicle is driving, passengers in it should sit in the seats and fasten the seat belts correctly; otherwise, in emergency braking or crashes, people in the car are more prone to severe injuries.**

In use of seat belts, the following instructions should be abided by:

- In a time length, a seat belt can only be used by one person. It's not allowed that two or more persons share one seat belt—even for children.
- Do not incline the seat back over. The seat belt has the best protection effect when the seat back is in the upright position. (Refer to instructions on seat adjustment)
- Caution: do not destroy the belt or hardware of the seat belt; prevent them from being caught in the seat or the door.
- Check the seat belt regularly to see whether it has cutting lines, worn or loose parts. Damaged parts should be replaced with new ones; the system should not be disassembled or modified.
- Keep the seat belt clean and dry. For cleaning, use neutral soap water or slightly hot water. Bleaching agents, dyes or grinding cleaning agents are not suitable for seat belt cleaning—they may severely reduce the protection performance of the seat belt. (See “Interior cleaning” in Section 5)
- After serious crashes, the seat belt system (including screws) should be replaced, even if the damage is not so marked.

#### Friendly Tips

**After the tab is inserted, make sure it is locked up firm to the buckle and the seat belt is not twisted.**

**Do not leave small objects, e.g. coins, paper clips, etc. in the buckle. They may affect the connection of the tab and the buckle.**

**If the seat belt functions abnormally, immediately inform BYD authorized service stations. Before repaired, it cannot protect passengers or children and may cause injuries.**

#### Three-point seat belt

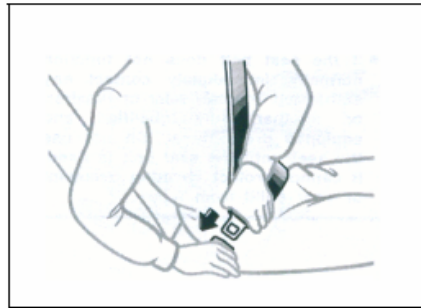

Adjust the seat according to your demand and sit upright in it; then, lean on the seat back. To fasten your belt, pull it out of the retractor and insert the tab into the buckle. After the tab is inserted into the buckle, a clicking sound can be heard.

Length of the seat belt can be automatically adjusted according to the passenger figure and the seat position.

In emergency braking or crashes, the retractor will lock the seat belt. If you incline forward too fast, it will also be locked. Slow and steady operation can lengthen the seat belt so that you can feel free.

If you cannot pull the seat belt out from the retractor, tug it and then release it slowly. Then, you can pull it out from the retractor successfully.

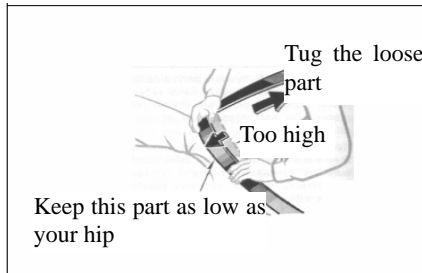

Adjust the seat belt at the waist and the shoulder.

Keep the waist belt as low as the hip as far as possible—do not buckle it at your waist. Then, tug the shoulder part upward through the catch plate and adjust the seat belt to an appropriate position.

### Friendly Tips

- **Waist seat belts fastened too high and seat belts assembled loosely may slide below the waist and cause severe injuries in crashes or other accidents. Therefore, keep the waist belt as low as the hip as far as possible.**

- **For safety considerations, do not place the shoulder seat belt below your arm.**

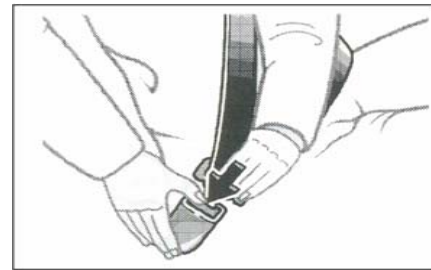

To release the belt, press the buckle-release button on the buckle. The seat belt will automatically retract.

If the seat belt cannot smoothly retract automatically, tug it out to see whether there is any knot or twist.

### Friendly Tips

- **It should be made sure that the shoulder seat belt passes over the shoulder center. The seat belt should be somewhat far away from the neck without sliding off the shoulder. Otherwise, its protection effect may**

be reduced and severe human injuries may be caused in crash accidents.

## Two-point seat belt

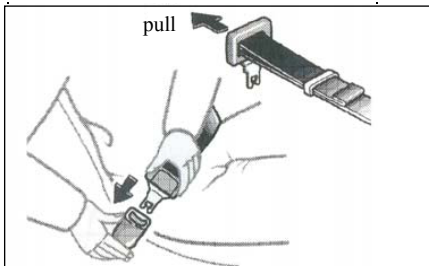

Sit upright in your seat and lean on the back. Fasten the seat belt and insert the tab into the buckle.

After the tab is inserted into the buckle, a clicking sound can be heard.

If the seat belt is not long enough, keep the tab perpendicular to the seat belt and tug the tab.

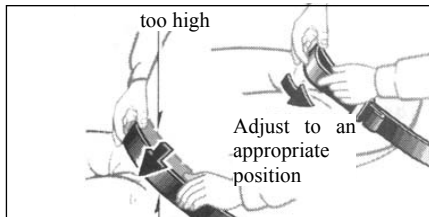

Retract the excessive length of the seat belt and adjust its position to keep it as low as the hip as far as possible.

To shorten the seat belt, tug the unfixed end. Keep the waist belt as low as the hip as far as possible—do not buckle it at your waist.

### Friendly Tips

- **Waist seat belts fastened too high and assembled loosely may slide below the waist and cause severe injuries in crashes or other accidents. Therefore, keep the waist belt as low as the hip as far as possible.**

### Supplemental restraint system (optional)

Supplemental restraint system (SRS, abbreviated as airbag system) is a supplement to seat belts. The airbag system can provide extra protection for heads and chests of the driver and passengers and reduce casualties in severe frontal crashes.

### Airbag for the driver and the front passenger

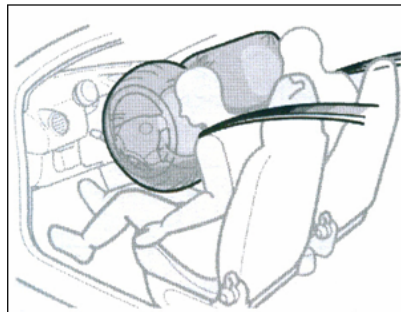

Sidebag and windowbag (Optional)

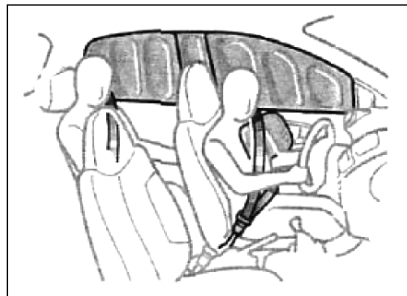

The airbag system cannot take the place of seat belts and is only a part of the whole passive safety protection system of the automobile. Note that the airbag system has

the best protection performance only when working together with fastened seat belts. Therefore, for the safety of yourself and your family, please pay special attention to the “Friendly Tips” and “Notice” in this section.

### Friendly Tips

**Please keep the seat belt fastened when the vehicle is driving!**  
**Please keep sitting in a correction posture so that the protection effect of the seat belt and the airbag system can be taken into full play.**  
**Do not dismount parts of the airbag without permission!**



**The airbag system is monitored by an electronic control unit and provided with self-diagnosis function. The system state can be indicated by a warning light on the combined meter:**

Each time after the ignition switch is turned on, the airbag warning light turns on for about 5s and then goes out for longer than 5s, the system can be considered as normal. If the airbag has already been deactivated by a BYD authorized service station, but the warning light still turns on and goes out as above, it means the airbag has no protection function.

The warning light system is used for monitoring the airbag ECU, the collision sensor, the inflation device, the warning light, wires and the power supply. (For details, please refer to “Maintenance indicators and warning buzzers” in Section 1-5.)

### Notice

**The following problems suggest faults of the airbag system:**  
**The warning light won't shine after the ignition switch is turned on.**  
**5s after the ignition switch is turned on, the warning light won't go out or start flashing again and shine after going out.**  
**The warning light turns on again after the ignition switch is turned off.**  
**The warning light turns on or flashes when the vehicle is driving.**

### Friendly Tips

**In case of faults, have the airbag system checked immediately in a BYD authorized service station. Otherwise, in accidents, partial or all function of the airbag system may be affected!**

### Airbag triggering conditions

The airbag is designed to be triggered under the following conditions: severe frontal collision accidents will trigger the airbag system; special collision accidents may trigger the airbag system.

In general, the airbag system won't be triggered in mild front collision or side collision accidents, in rear end collisions or in turn-over accidents. In such accidents, the seat belt, if fastened, can protect the driver in the normal way.

The decisive factor for triggering the airbag system is the comprehensive intelligent comparison and judgment of the deceleration curve produced in a collision and acquired by the electronic control unit (ECU) and the set value. If the automobile deceleration signal produced and detected in the collision is lower than the set reference value in the ECU, the airbag won't be triggered even though the car may have been severely deformed in the accident.

ECU setting of BYD airbag system takes various common misuse and domestic road conditions into full consideration. However, reasons and conditions of crashes are variable, so, for your safety, please abide strictly by this manual, use the automobile correctly and avoid misuse; otherwise, the expected protection effect of the airbag cannot be ensured.

### Protection principle of the airbag

Once the airbag system is triggered, air will be immediately inflated into the airbag and make it full in front of the driver and the passenger. The occupants will fall into the expanded airbag and the forward inertia will be polished, thereby reducing the degrees of injuries to their heads, necks and chests. The specially developed airbag can, after expanded and then pressed by the driver and the passenger in an accident, absorb energy and discharge the air out at a certain rate so as to reduce the effort of the airbag on the occupants and relieve injuries to them. After the accident, air in the bag can be basically discharged, so the forward vision won't be hindered.

The airbag can be expanded within a few fractions of a second so as to provide extra protection for the driver and the passenger in accidents.

Airbag expansion can produce a rather loud noise but, in general, won't cause injuries (the possibility of ear ringing or temporary deafness is not excluded, but these problems, if happening, can recover soon). The gas produced in triggering the airbag system may have some smell but won't lead to

occupant poisoning. A little smoke will be emitted after the airbag is expanded; it's normal and not the indication of a fire, so please do not worry about it.

**The airbag system possibly won't be triggered in the following accidents:**

Hitting on a cement pole, a tree or other slim objects

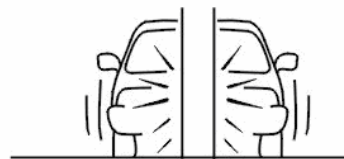

Crashing into the bottom of a truck

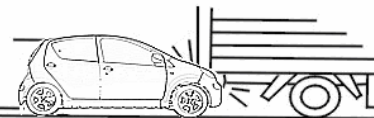

The airbag may be triggered in the following accidents:

Rear Crash

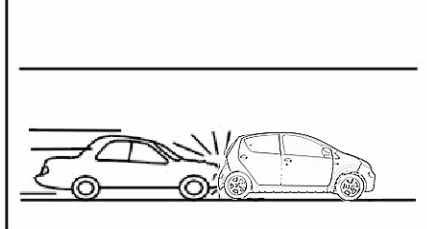

Hit by other vehicles on the side

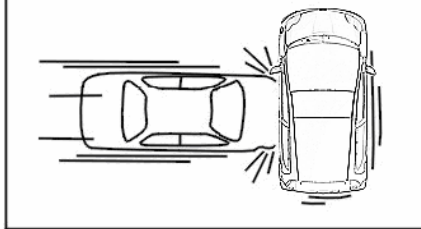

Hitting on protruding objects, a safety island or stones by the road



Bumping into the wall with an angle

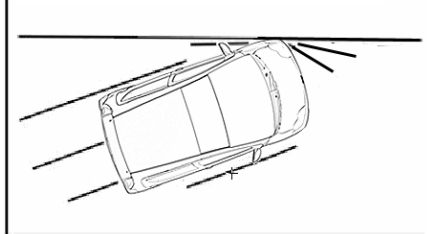

Side rollover

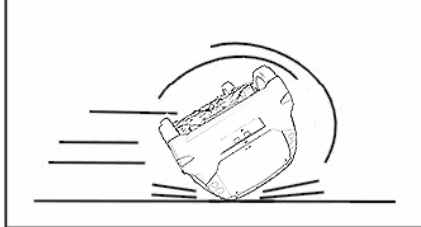

Bumping into a deep hole

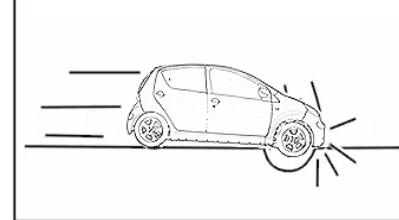

The airbag possibly won't be triggered in the above cases as shown in the figures.

Hitting on the ground at the bottom of a slope

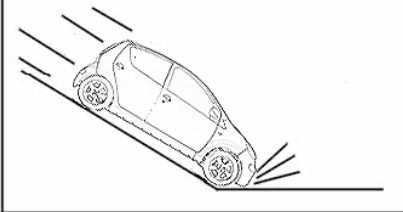

The above accidents as shown in the figures may trigger the airbag.

The airbag may be triggered if the automobile is severely impacted by the bottom.

#### Notice

The airbag is designed to match the certain vehicle models. Any changes of the suspension, the tire size, the bumper, the chassis and other original equipment may adversely affect the function of the airbag. In addition, it is strictly prohibited to apply any airbag parts to other vehicle models; otherwise it might lead to safety airbag system failure, resulting in personal injuries.

During driving, please wear the seat

belt correctly and maintain a correct sitting posture. If you haven't worn the seat belt and lean forward or sit in an incorrect posture, the risk of injuries in accidents with airbag expansion may be increased.

It's very important for the driver to maintain a distance of at least 25cm between the chest and the steering wheel since only by doing so can the maximum protection effect be provided when the system is triggered. That is to say, it's necessary to adjust the front seats and the headrest according to the figure of each occupant; in addition, the driver's arms should be bent only a little and stretched nearly straight.

Do not paste or cover the surface of the steering wheel lid or the surface near the airbag on the right of the instrument panel with any objects or do any other decorative treatment. Telephone supports, cups, ashtrays, etc. can increase the risk of injuries in accidents with airbag inflation.

The surface of the steering wheel lid or the surface near the airbag on the

right of the instrument panel should be cleaned with only dry or slightly wetted cloth and should not be knocked at violently.

Don't let child passenger sit in the front seat without protection. If a collision triggers the air bag, the child passenger may get seriously injured or even killed.

Don't stay or put any animals or objects near the driver, the front seat passenger and the air bags. It is extremely dangerous for an adult to hold a child on the legs.

Don't make any modifications to none parts of the airbag system, including corresponding labels.

All modification to the airbag, including the repair other parts (such as detachment of the steering wheel) can only be made in BYD authorized service stations.

The airbag system must be replaced in a BYD authorized service station within 15 years as of the date of delivery (manufacture date indicated in the certificate).

The air bag can only provide protection once. Once the air bag is



triggered or damaged, the system must be replaced.

Please hand our materials to the next owner of the vehicle in transfers. Please note that if the airbag is shut down, the information should be informed the next owner of as well.

When disposing the parts of the vehicle or the airbag system, please comply with correlative safety regulations and disposal procedures. BYD authorized service stations have a good knowledge of these regulations and the detailed disposal procedures. The air bag system has strong resistance capacity against the surrounding electromagnetic interference. However, to avoid accidents, please do not use the vehicle beyond the electromagnetic environment specified by national laws.

The airbag system of BYD auto has taken into full consideration various kinds of misuses and road conditions. However, avoid serious crashes happen in the bottom of the vehicle or drive toughly in poor road conditions in order to prevent accidents.

### Shut down the airbag

According to applicable regulations, airbags for the driver and the passenger in the front seat can only be shut down in some cases such as:

- When it is impossible to keep a 25cm distance between the center of the steering wheel and the chest of the driver even though the driver seat is adjusted properly.
- When special equipment needs to be installed for the disabled within the range of the steering wheel.
- When the front seats cannot maintain the manufacturer's setting location after adjustment due to some reasons

Shutdown of the airbag system should be conducted by a BYD authorized service station. After a certain airbag is shut down, the BYD authorized service station will paste a label on the corresponding position and make a record.

### Friendly Tips

If the air bag system needs to be shut down in some special occasions, please have it done in a BYD authorized service station. Otherwise, serious injuries or death may be incurred!

- If the airbag protection function is to be recovered, please go to a BYD authorized service station for help.

### Supplemental information

● Please read this manual thoroughly. If you want to sell or disconnect the vehicle, please notify the owner or the demolition department that the car is equipped with the airbag system, and recommend them to read the manual carefully.

● If the airbag system is working, please don't touch any part of the airbag module (you may be burned), and ask a BYD authorized service station for detachment treatment. Once the air bag system has functioned, please install a new airbag system after it is removed.

● The airbag system only functions in case of serious frontal collisions. It doesn't mean that the airbag system has problems when it doesn't respond to the collision. Incorrect maintenance or failure to repair faulty parts may affect the normal performance of the airbag system.

### System parts

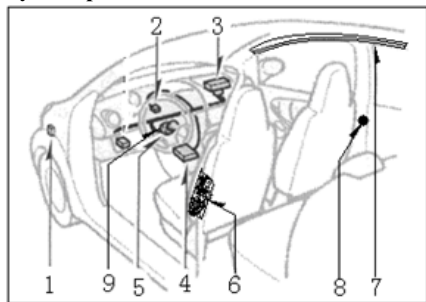

The airbag system consists mainly of the following parts, the arrangement of which is shown in the above figure:

1. airbag collision sensor (bisidely symmetrical)
2. SRS warning light
3. airbag module for the occupant in the front row (airbag and inflation device)

4. central control unit (ECU)
5. airbag module for the driver (airbag and inflation device)
6. airbag module for seat side (bisidely symmetrical) (Optional)
7. window bag module (bisidely symmetrical) (Optional)
8. side collision sensor (bisidely symmetrical) (Optional)
9. clock spring

### Considerations

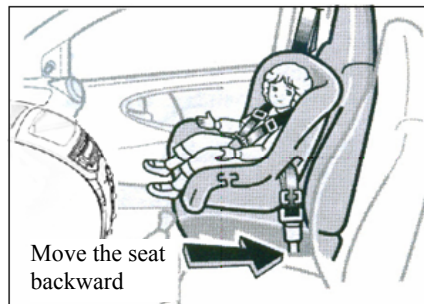

### Warning

- Child protection equipment should not be added to the front passenger seat unless necessary. Since the airbag for the occupant in the

front row can inflate quickly with high tension, so do move the seat backward as far as possible. Otherwise, it may cause injury or even death of children sitting there.



### Warning

- When the vehicle is driving, do not sit on the edge of the seat or bend over the instrument panel, since when the airbag inflates fast with powerful force, occupants directly contacting or nearing the airbag may be killed or severely injured. Please keep sitting in a correct posture and please fasten your seat belt correctly.

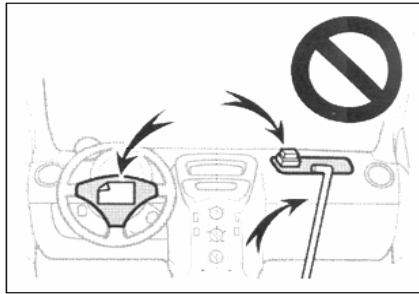

● Nonobservance of these instructions may lead to deaths or severe injuries. Please consult BYD authorized service stations for detailed items on repair and modification.

**Side Airbag**

- The driver's seat and driver's side equipped with side airbag
- The rear seat is best safety for children
- Do not rely on the door
- Details are set out in the owner's manual

**Warning**

- BYD strongly suggests seating and correctly fixing all babies and children in the rear seat.
- Never allow children to stand or kneel down on the front seat. The airbag for the occupant in the front seat can inflate rather quickly with powerful force and may kill or severely injure the children.
- Do not place children on your knees or hold them in your arms. Please equip children protection devices on the rear seat.

**Warning**

- Please do not place any object on or contact your body the front of the instrument panel or the steering wheel pad. They may hinder airbag inflation or the inflation tension of the air bag can shoot them out and lead to personal death or injuries. Similarly, the driver or the occupant in the front seat should not carry objects with hands or put object on the knees.
- Please do not modify or move any wire. Please do not modify, move, knock or disassemble any part. Otherwise, normal work of the airbag may be affected; the system may work abnormally or even won't work, causing deaths or severe injuries.

**Warning**

- Side air bag inflating may result in serious injuries or even death if body tilt forward on the front door.
- To remind you of danger of side airbags, your vehicle is posted with warning signs on both sides of the front door frames.

**Warning**

Do not modify the airbag system in the following ways before consulting BYD authorized service stations. These modifications may affect the normal work of the airbag system in some cases.

- Installing electronic devices, e.g. vehicle AM/FM radios, cassette players or CD players.
- Modifying the suspension system.
- Modifying the front end structure and side structures of the occupant compartment.
- Adding grille protection accessories (protection grilles, bucket rods, etc.) snowplows, winches or other devices connected to the front end.
- Doing repair work at the lower parts of the front mudguard, the front end structure, the control console, the steering column, the steering wheel and the instrument panel or on or near the instrument panel near the airbag for the front seat.

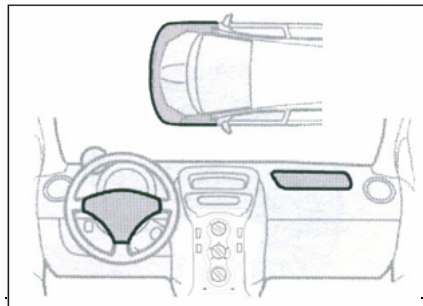
**Warning**

Please contact a BYD authorized service station in case of the following problems:

- The airbag has been inflated.
- The front part of the vehicle (shaded part in the figure) is affected in an accident; but it's not serious enough to trigger the airbag.
- The panel part of the steering wheel, the instrument table or the lower part of the instrument panel (shaded parts in the figure) is scratched, cracked or damaged in similar ways.

**Notice**

- Do not disconnect the battery before contacting the BYD authorized service station.

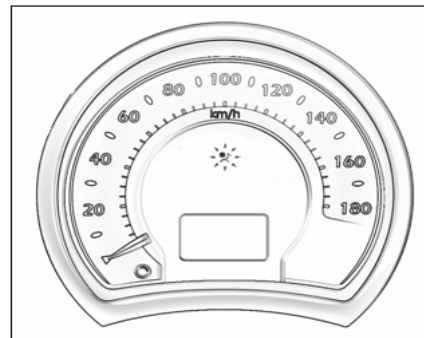
**SRS warning light**

When the ignition key is shifted to “II” and if there is no fault, the SRS warning light will shine for 5s and then goes out.

Steering wheel



To change the steering wheel angle, hold the steering wheel, push down the lock release lever, tilt the steering wheel to the desired angle and return the lever to its original position.

Notice

- Do not adjust the steering wheel while the vehicle is moving. This may cause the driver to mishandle the vehicle and an accident may occur.
- After adjusting the steering wheel, try to move it upward and downward to make sure that it is locked in position.

Outer rearview mirrors

Adjustment of outer rearview mirrors with adjusting switches (optional)

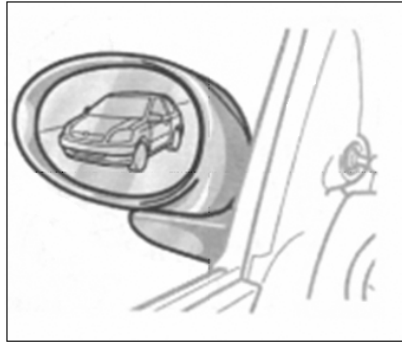

Adjust the outer rearview mirrors to an angle where you can just see side sides of the vehicle.

Friendly Tips

- Do not adjust the rearview mirrors when the vehicle is driving. In doing so, the driver may control the vehicle incorrectly and cause accidents.

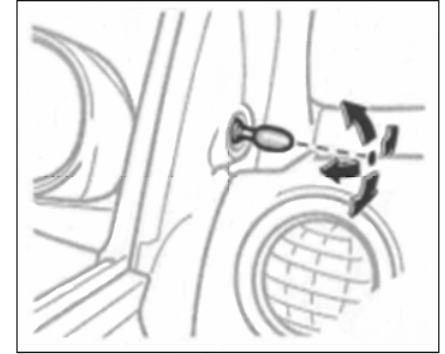

Adjust the rearview mirror with this switch. Move the switch into the desired direction.

Notice

- ◆ If the rearview mirror is fixed by freezing, do not manipulate the controller or scrape the surface of the rearview mirror. The ice on the surface of the rearview mirror should be removed with a spraying deicer.

### Adjustment of outer rearview mirrors without adjusting switches

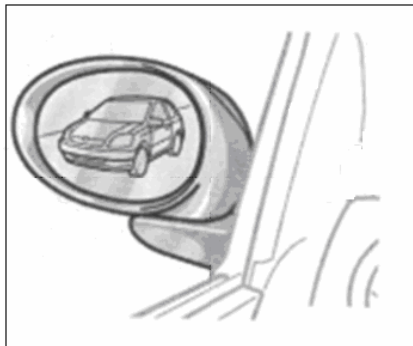

Adjust the outer rearview mirrors with your hand to an angle where you can just see side sides of the vehicle.

In addition, please pay attention to contents in the “**Friendly Tips**” and “**Notice**” on the previous page.

### Folding of outer rearview mirrors

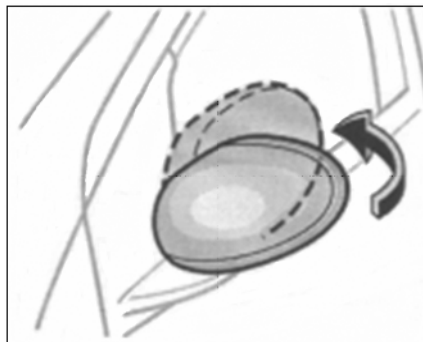

The outer rearview mirrors can be folded backward as shown in the above figure.

#### Notice

- ◆ **Please do not exceed its journey when folding the outer rearview mirror backward; otherwise, it may be damaged.**

#### Friendly Tips

- **Please do not drive when folding the outer rearview mirror backward. Please adjust the outer rearview mirror before starting to drive.**

### Inner rearview mirror

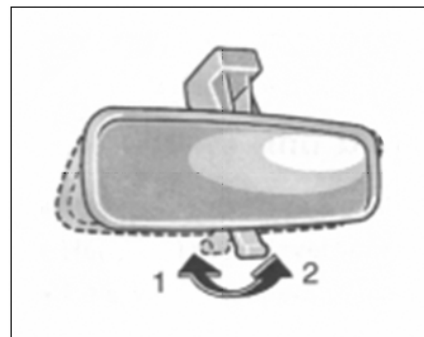

Adjust the inner rearview mirror to an angle where you can just see the rear of the vehicle in it.

In night driving, you can pull the adjusting rod toward yourself to weaken the dazzling irradiation of front lights of the following vehicle.

Daytime driving—the rod is in position 1.

When the rod is in this position, reflection in the rearview mirror has good clarity.

Night driving—the rod is in position 2.

The rearview clarity may be reduced by some extent for glare weakening.

**Section 1-4****Operation of Instruments and Controllers****4. Lighting, wipers and defrosters**

Headlights and turn signal lights.....	37
Emergency warning lights .....	38
Rear fog lights.....	38
Reading light.....	39
Front windshield wipers and washers .....	39
Rear windshield wipers and washers .....	39
Rear windshield defrosters (optional).....	40
Front fog lights (optional).....	41

## Headlights and turn signal lights

### Head lights

Rotate the head light knob at the top end of the left combined switch to turn on the following lights:

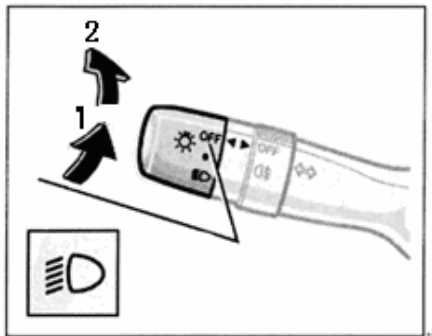

**Position 1**—parking lights, tail lights, registration plate lights, background lights of the combined meter, indicator (green) of parking lights on the combined meter, and tail light indicators.

**Position 2**—head lights and all above-mentioned lights.

### Light indication buzzer

If the parking lights are on and the ignition key is in position “0”, the light indication buzzer will remind turning off the lights when you open the door at the driver side.

#### Notice

◆ **For prevention of battery discharge, when the engine is in rest state, do not keep lights on for long time.**

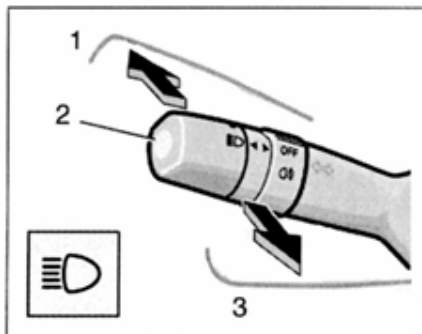

**High beam and low beam lights**—rotate the light knob at the top end of the left combined switch to the front lighting light position. Pull the left combined switch to position 2 to turn on Low beam lights; push the left combined switch away from yourself (to position 1) to turn on the high beam. Then both high beam and low beam lights are on.

The high beam indicator (blue) on the combined meter indicates that the high beam are on.

**Flashing high beam** (position 3)—pull the left combined switch toward your body (position 3). When the left combined switch is released, the high beam will stop flashing. The high beam indicator (blue) on the combined meter indicates that the high beam are flashing.

When the knob is rotated to the “OFF” position, the high beam will flashing.



## Turn signal lights

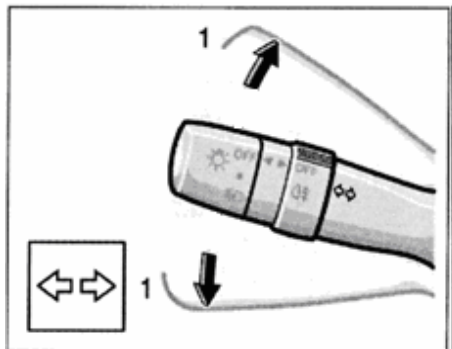

To send out a steering signal, turn the left combined switch upward or downward to position 1.

The ignition key should be in position “II” .

After the vehicle has made the turn, the handle can return to its original position automatically. But in lane changes, it should be manually returned.

## Emergency warning lights

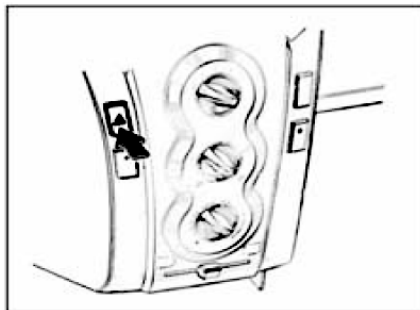

To turn on emergency warning lights, press this switch down once. Then, all turn signal lights will flash. To turn off the lights, press this switch again.

If the vehicle has to be parked where traffic accidents can be caused, the emergency warning lights should be turned on to remind other drivers. If possible, park the vehicle away from the road.

When emergency warning lights are on, the steering signal light switch won't function.

Notice
<p>◆ For prevention of battery discharge, when the engine is in rest state, do not keep lights on for long time.</p>

## Rear fog lights

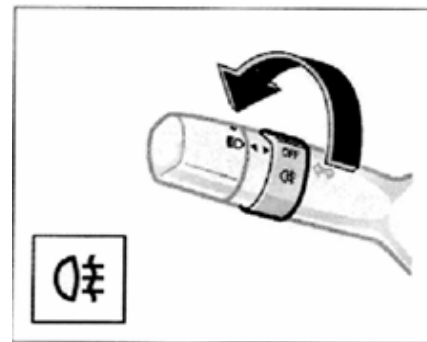

Rotate the lighting knob to the front lighting light position and then rotate the signal light knob (shaded part in the figure) to position “R” to turn on rear fog lights.



The rear fog light indicator (yellow) on the combined meter will indicate the rear fog lights are on.

When the lighting knob is rotated to “OFF”, the signal light knob will automatically rotate to position “OFF” and the rear fog lights will automatically go out.

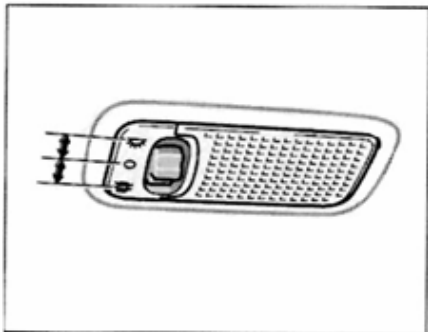
## Reading light



Slide the switch to turn on the reading light. The reading light switch has the following positions:

- “” (ON)——keep the lights on.
- “” (OFF)——turn off the reading light.
- “” (DOOR)——when the door is opened, the light will be turned on; after the

door is closed, the light will be turned off.

## Front windshield wipers and washers

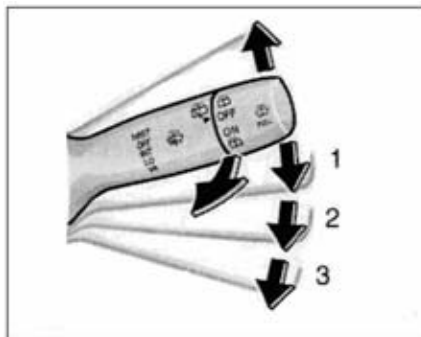

To turn on the front windshield wipers, the ignition key should be in position “II”. Turn the right combined switch to the desired set position.

Position	Speed Setting
position 1	intermittent
position 2	slow
position 3	fast

To wipe the front windshield only once, push the right combined switch upward and then release it.

To eject detergent, turn the right combined switch to yourself and then release it.

For details on detergent addition, please refer to “Detergent addition” in Part 3 of Section 7.

In freezing weather, to use the washers, the windshield should first be heated with the defrosters. Otherwise, the detergent may freeze on the windshield and hinder your vision.

### Notice

- ◆ **Do not turn on the water wipers when the front windshield is dry; otherwise, the glass may be scraped.**

## Rear windshield wipers and washers

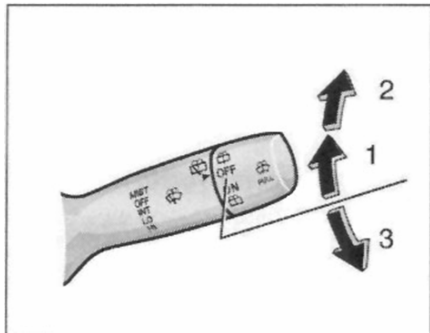

To turn on the front windshield wipers, the ignition key should be in position “II” . Turn the rear wiping and washing knob to position “ON” (position 1).

To eject detergent, rotate the rear wiping and washing knob upward or downward as far as possible (position 2 or position 3). After released, the knob can automatically return.

For details on detergent addition, please refer to “Detergent addition” in Part 3 of Section 7.

### Notice

◆ **Do not turn on the water wipers when the front windshield is dry; otherwise, the glass may be scraped.**

## Rear windshield defrosters (optional)

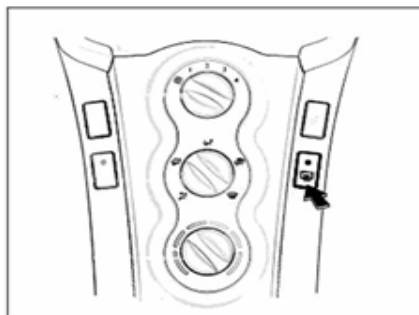

To remove fog or frost on the rear windshield, press this switch down. The ignition key should be in position “II” . The thin electric heating wires in the rear windshield can quickly make the rear windshield clear. At the same time, the rear

windshield defroster switch indicator turns on, indicating the defrosters are working. The defrosters can be turned off by pressing this switch again.

When the rear windshield becomes clear, make sure the defrosters are turned off. Long-time working of the defrosters may lead to battery discharge. The defrosters are not designed for drying raindrops and snowmelt.

### Notice

◆ **To prevent battery discharge, turn off the defrosters when the engine is stopped.**

◆ **When cleaning inner surface of the rear windshield, take care not to scrape or damage the electric heating wires or the connectors.**

## Notice

◆ Do not turn on the water wipers when the rear windshield is dry; otherwise, the glass may be scraped.

## Front fog lights (optional)

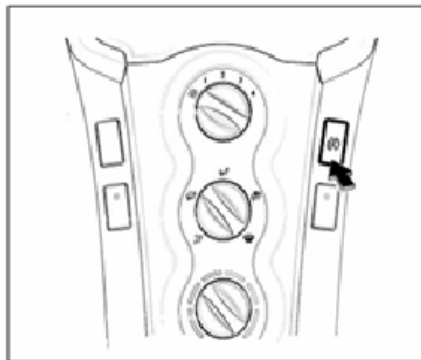
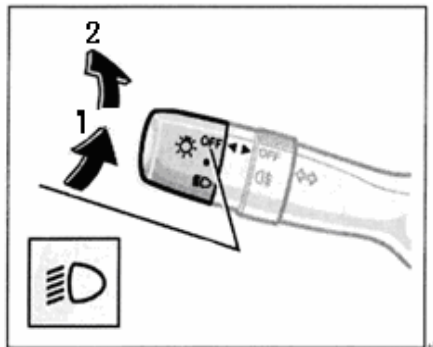

To turn on the front fog lights, first rotate the left combined switch lighting knob to position 1 or 2 and then press the front fog light switch; otherwise, even if the front fog light switch is pressed down, they won't shine.

The front fog light indicator (green) on the combined meter will indicate the front fog lights are working.

To turn off the front fog lights, turn off parking lights or press the front fog lights down again.

## **Section 1-5**

### **Operation of instruments and controllers**

#### **5. Instrument and maintenance indicators**

Fuel gauge.....	43
Engine coolant temperature warning light .....	43
Speedometer (optional).....	44
Odometer, trip odometer .....	44
Instructions on maintenance indicators and warning buzzers .....	45

## Fuel gauge

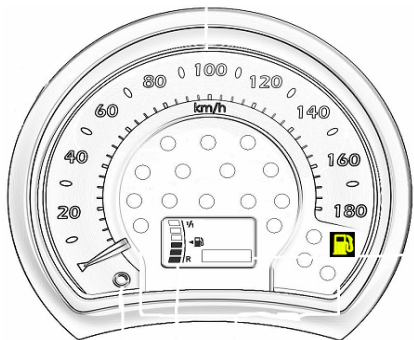

When the ignition key is in position “II”, the fuel gauge detects and displays the approximate volume of fuel remaining in the fuel tank.

Fuel tank is nearly full—dialing position “1/1” ;

Fuel nearly runs out—dialing position “R” .

The fuel level should be kept at 1/3 or above of the fuel tank capacity.

When the fuel level is near “R” or the low fuel level warning light turns on, the fuel tank should be filled immediately.

On slopes or turning roads, the fuel level

display may fluctuate due to motion of fuel in the fuel tank, or the low fuel level warning light may shine earlier than usual.

## Engine coolant temperature warning light

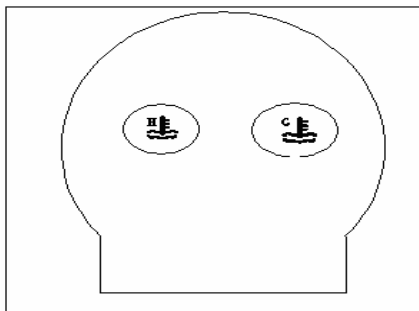

When the ignition key is in position “II”, the engine coolant temperature warning light on the combined meter can indicate the temperature state of the engine coolant if it is too high or too low. The working temperature of the engine will change with whether and the engine load.

When the ignition key is rotated to position “ II ” and if the engine coolant

temperature is normal, the engine coolant low-temperature warning light will shine for 6s and then go out.

## Engine coolant temperature is too high

If the engine coolant temperature is too high, the high-temperature warning light will shine; if the engine temperature increases continually, the light will continue shining. If the temperature is too high, stop and let the engine cool.

Under the following working conditions, the engine may become too hot:

- Climbing for long in hot weather.
- Slowing down or stopping after driving at high speed.
- Driving with frequent stops or idling the engine for long with the air conditioning system turned on.
- Towing a trailer.

## Notice

◆ Do not take the thermostat in the engine cooling system away; otherwise, the engine may become too cold. The thermostat is used for controlling flow of the coolant so that the engine temperature can be kept in the regulated operation range.

◆ If the engine is too hot, stop driving immediately. Refer to “If the auto is too hot” in Section 4.

**Engine coolant temperature is too low**

If the engine coolant temperature is too low, the low-temperature warning light will shine; if the engine temperature drops continually, the light will continue shining. If the engine temperature is too low, please pre-heat the engine and then actuate the automobile.

## Speedometer (optional)

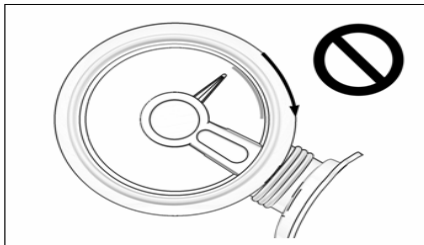

The speedometer displays the rotation speed of the engine by rpm (rounds per minute). It's used for selecting the proper shifting time in driving so as to prevent lug down and over-speed operation of the engine.

Driving with the engine rotating at over-speed will lead to over-wear of the engine and fuel waste.

When the ignition switch is turned to position “III”, zero-return of the speedometer dial doesn't indicate faults.

## Notice

◆ If the dial goes into the red region, the engine may be severely damaged.

## Odometer, trip odometer

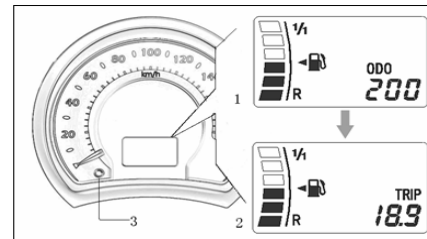

The LCD provides the following information:







1. Odometer—displaying the total mileage your auto has run for.
2. Trip odometer—displaying the mileage your automobile has run for since when the trip odometer was set as zero.

3. Trip odometer zero-return button—for adjusting the display of the trip odometer to zero and switching the meter display.



To switch the meter display, quickly press and release the button. The display will be switched from the odometer to the trip odometer and vice versa.

To adjust the display of the trip odometer to zero, first display the reading of the trip odometer and then hold the button until the display becomes zero.

### Instructions on maintenance indicators and warning buzzers

	If the indicator turns on or the buzzer buzzes...	Do according to the following instructions
(a)		If the parking brake is not used, please stop immediately and contact a BYD authorized service station.
(b)	 (indicator and buzzer)	Fasten the seat belt for the driver
(c)		Stop and check
(d)		Stop and check
(e)		Send the automobile to a BYD authorized service station
(f)		Check whether all doors are closed.



(g)		Stop and check
If the indicator turns on or the buzzer buzzes...		Do according to the following instructions
(h)	 (optional)	Send the automobile to a BYD authorized service station. If the braking system warning light also turns on, stop immediately and contact a BYD authorized service station.
(i)	 (optional)	Immediately send the automobile to a BYD authorized service station for maintenance.
(j)	Light indication buzzer	Turn off the lights.

**(a) Brake system warning light**

When the ignition key is in position “II” , the light will shine in the following conditions:

- When the brake fluid level is low.
- When the parking brake is drawn for parking.

Friendly Tips
<ul style="list-style-type: none"> <li>● It's very dangerous to drive when the brake fluid level is low.</li> </ul>



**Have the vehicle checked in a BYD authorized service station if the following problems occur:**

- The ignition key in position “II” , the light won't shine even when the parking brake is used.
- The ignition key in position “II” , the light won't go out even when the parking brake is released.

Temporary shining of the warning light doesn't suggest fault existence.

Friendly Tips
<p><b>In case of any of the following problems, stop and park the vehicle in a safe place immediately and contact a BYD authorized service station:</b></p> <ul style="list-style-type: none"> <li>● The engine running, the light won't go out even when the parking brake is released.</li> </ul> <p><b>Under such conditions, the brake may be working abnormally and the brake distance will be lengthened. Push the brake pedal forcefully so stop the vehicle immediately.</b></p> <ul style="list-style-type: none"> <li>● The brake system warning light turns on while the “ABS” warning light is shining.</li> </ul> <p><b>Under such conditions, not only the ABS system won't function in braking, but also the vehicle will become extremely unstable.</b></p>



**(b) Driver seat belt indicator and indicator buzzer**

The light and the buzzer are used for reminding the driver to fasten the seat belt.

Once the ignition key is turned to position “II” and if the seat belt for the driver is not well fastened, the indicator will flash for 6 times and the buzzer will buzz for 6 times. If then the vehicle remains still, the indicator will shine continually and the buzzer will stop buzzing; if then the vehicle is driving, the indicator will flash for 6 times and the buzzer will buzz for 6 times every 30s.

**(c) Discharge indicator**

The light is used for indicating that the battery is in discharging state.

When the ignition key is in position “II” , the indicator will shine; in normal conditions, after the engine is started, the indicator will go out.

Notice
--------

<p>◆ <b>Shining of the light during engine operation indicates faults of the charging system or break of the engine belt. Please drive the vehicle away from the road and park it in a safety place and then immediately stop the engine. Inform a BYD authorized service station for help.</b></p>
---

**(d) Low engine oil pressure indicator**

The light is used for indicating that the engine oil pressure is too low.

In driving, if the light flashes or keeps shining, drive away from the lane and park the vehicle in a safety place and then immediately stop the engine. Ask a BYD authorized service station for help.

The light may flash occasionally when the engine is idling or shine temporarily after emergency braking.

However, if it goes out when the engine accelerates gradually, the problem may be neglected.

When the engine oil level is very low, the light can also shine. This light is not used for showing low engine oil levels; the engine oil level should be determined with an oil measuring tape.

Notice
--------

<p>◆ <b>Do not drive the vehicle—even for a short distance—when the indicator is shining; otherwise, the engine may be damaged.</b></p>
---

**(e) Engine fault indicator**

The light will shine if the electronic fuel injection system of engine has faults or the pollutant emission has exceeded the control standard.

If the light turns on in driving, inform a BYD authorized service station to examine the vehicle as soon as possible.

**(f) Door-open warning light**

Whatever position the key is in, the warning light will shine as long as there is a door open.

**(g) Low fuel level warning light**

The light will shine if the fuel in the fuel tank nearly runs out. Add plenty of fuel as soon as possible.

When the vehicle is climbing a steep slope or turning, the low fuel level warning light may shine earlier than usual due to shake of the fuel in the fuel tank.

**(h) “ABS” warning light (optional)**

When the ignition key is turned to position “II”, the warning light will shine. If the ABS system works normally, the warning light will go out after a few seconds. If the system has faults, the warning light will shine again.

When the “ABS” warning light is shining (the brake system warning light is out), the ABS system won't work, but the brake system can still work normally.

When the “ABS” warning light is shining (the brake system warning light is out), the ABS system won't work, so in emergency braking or braking on slippery roads, the wheels will be locked.

Both of the conditions can indicate certain monitoring parts in the warning light system have faults. If either of the conditions happens, contact a BYD authorized service station as soon as possible to have the vehicle checked.

- When the ignition key is turned to position “II”, the light shine is on continually or can not turn on.
- The light turns on in driving.

In operation, temporary shining of the warning light does not suggest problem existence.

#### Friendly Tips

- **If the “ABS” warning light turns on when the brake system warning light is shining, park the vehicle in a safe place immediately and contact a BYD authorized service station.**

**Under such cases, not only the ABS system won't work in braking, but also the vehicle will become extremely unstable.**

#### (i) SRS warning light (optional)

The ignition key turned to position “II”, the light turns on for about 5s and then goes out, indicating the airbag system is working normally.

The warning light system is used for monitoring the airbag ECU, the collision sensor, the inflation device, the warning lights, wires and the power supply.

If any of the conditions happens, it means certain parts monitored by the warning light system have faults. Contact a BYD authorized service station as soon as possible to have the vehicle checked.

- When the ignition key is turned to position “II”, the light turns on for about 5s and then keeps flashing.
- When the ignition key is turned to position “II”, the light won't shine or flash.
- The light turns on in driving.

#### (j) Lighting indication buzzer

When the parking lights or head lights are on, the ignition key is turned to position “0” or taken away, and the door at the driver side is not closed, the buzzer will sound to remind the drive to turn off the parking lights or head lights before leaving the vehicle.

**Section 1-6****Operation of Instruments and Controllers****6. Ignition switch and parking brake**

Ignition switch with steering wheel self-locking mechanism .....	51
Parking brake .....	51

## Ignition switch with steering wheel self-locking mechanism

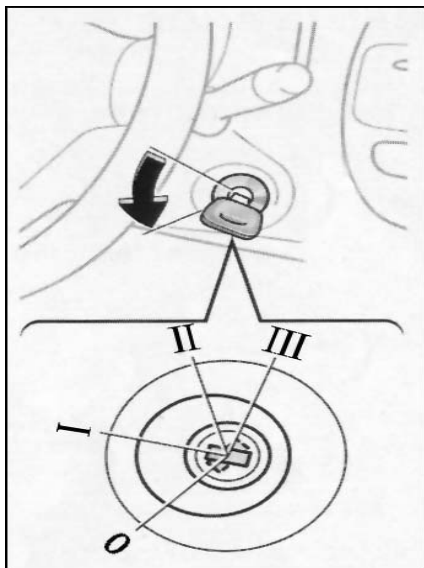

“III” ——Start the starter. After released, the key will return to position “II” .  
For the starting method, refer to Section 3.

“II” ——Start engine operation and powering all accessory electric appliances.

This is the position for normal driving.

“I” ——Accessory apparatuses, e.g. the radio, can operate, but the engine stops.

“0” ——The engine stops and the steering wheel is locked. The key can be taken off only when in this position.

The key can be turned from position “I” to “0” only after pressed in.

In engine startup, the key seems to be caught in position “0” . To release it, first make sure it is completely inserted in and then rotating the steering wheel when turning the key.

When the ignition key is turned to position “III” , “I” or “0” , if dials of the speedometer and the tachometer returns to the bottom or only swing a little, faults are indicated.

### Friendly Tips

- **It is forbidden to take the key out in driving; otherwise, the steering wheel will be locked and the steering operation will go out of control.**

### Notice

- ◆ **When the engine is free, to prevent battery discharge, do not keep the key in position “I” .**

## Parking brake

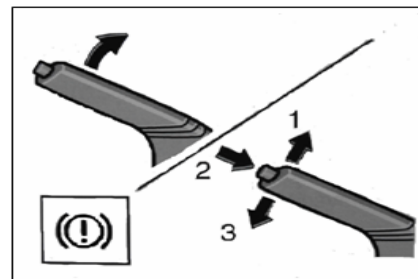

In parking, lift up the parking brake firmly to prevent the vehicle from sliding.

Applying: Lift the handle of the parking brake. To get better retaining force, push and hold the brake pedal with your foot until the parking brake is lifted up.

Release: Lift the handle of the parking brake lightly (1), press in the lock-release button (2) and then put the parking brake down (3).

The parking brake indicator will shine until the parking brake is released to show the parking brake has been set.

<b>Friendly Tips</b>
<ul style="list-style-type: none"><li>● <b>Before driving, make sure the parking brake is completely released and the parking brake indicator is out.</b></li></ul>

**Section 1-7****Operation of Instruments and Controllers****7. Auto audio system**

Audio system reference.....	54
Function instruction of the central control interface .....	55
Operation of the audio system.....	56



**Audio system reference****Functions and characteristics**

1. CD play
2. Built-in AM/FM radio
3. Shock-proof structure
4. 30W×4 maximum power output (loudspeaker)
5. Audio input support
6. Clock display

## Function instruction of the central control interface

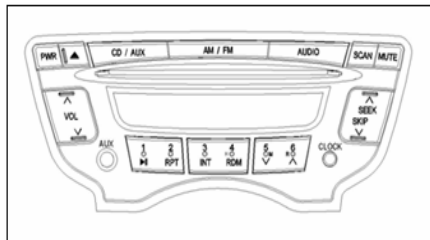

### “1 2 3 4 5 6” keys

The keys are used for saving channels and listening to programs of the saved channels.

**Save a channel:** You can save the current channel by holding down a numerical key. The corresponding figure can be displayed on the LCD screen at the same time.

**Listen to programs of a saved channel:** You can listen to programs of a saved channel by pressing the corresponding numerical key. The corresponding figure and the channel frequency will be displayed on the LCD screen at the same time.

Each key can save two AM channels and three FM channels. (When the “AM/FM” key is pressed, the LCD will show “AM1”, “AM2”, “FM1”, “FM2” and “FM3” in sequence.) If power supply of the audio system is cut off (the system is disconnected from the battery or the fuse is burnt out), the saved channels will be cleared.

### Disc unloading key “▲”

Press this key to unload the CD disc.

### “SEEK/SKIP (∧ / ∨)” key

**AM FM radio:** Press the “SEEK/SKIP (∧ / ∨)” to select channels of different frequencies.

Hold down the “SEEK/SKIP (∧ / ∨)” key to search channels with signals automatically.

**CD player:** Press the “SEEK/SKIP (∧ / ∨)” key to play the next/previous music file.

Hold the “SEEK/SKIP (∧ / ∨)” key to enter fast-forward or fast-backward mode; release the key to recover normal playing.

### “Power” key

Press the “Power” key to turn on or turn off the audio system. When the ignition key is in position “II” or “I”, the audio system can work.

### “VOL (∧ / ∨)” key

Press the “VOL (∧ / ∨)” key to adjust the sound volume.

### “AM/FM” key

Press the “AM/FM” key to switch between AM and FM.

### “SCAN” key

In AM/FM radio mode, hold this key to automatically save channels. Press this key to fast browse the saved channels.

### “AUDIO” key

Press the “AUDIO” key to enter the audio-effect adjustment mode and select audio effect from the cycle of “bass (BAD)-treble (TRE)-balance (BAL)-front and rear direction (FRD)”. When a certain mode is switched to, press the “VOL (∧ / ∨)” key for adjustment.

## “CLOCK” key

Hold this key to enter the clock adjustment mode. Press “4(H)”, “5(M)” and “6(R)” respectively for hour, minute adjustment and minute zero-return.

## “CD/AUX” key

**CD play:** Press “CD/AUX” key to switch to the CD mode.

**AUX play:** If you want to listen to music files in a portable player, e.g. CD, MD or MP3, you can connect the device to the vehicle system by the AUX interface with an audio frequency cable and play the music files.

## “RDM” key

If you press this key, the LCD will show “RDM” and then play the music files in the CD disc in a random order. Press the “RDM” again to cancel the random play mode.

## “RPT” key

If you press this key, the LCD will show “RPT” and then repeat playing the music files in the CD disc. Press the “RPT” again to cancel the repeating play mode.

## “INT” key

If you press this key, the LCD will show “INT” and play the beginnings of the music files in the CD disc in a browsing mode. Press the “INT” again to cancel the browsing play mode.

## Operation of the audio system

Notice
<p><b>To use the audio system properly, the following instructions should be followed:</b></p> <p><b>Take care not to sprinkle drinks onto the audio system.</b></p> <p><b>Do not insert any foreign objects into the CD slot except CD discs.</b></p> <p><b>It's normal that noise may be given out by the loudspeakers of the working audio system if a mobile communication device, e.g. a mobile phone, is being used in or near the vehicle.</b></p>

## Radio

The broadcasting range of the FM radio is about 40km. If the vehicle is far away from signal emission towers of radio stations, the audio effect will become bad; you have to

search radio signals again. In addition, FM radio signals are short wave signals which may be intercepted by tall buildings or high mountains. The radio is not to blame for bad receiving effect for such reasons.

## Radio antenna

The radio antenna can be detached by rotating the antenna pole anticlockwise.

Notice
<p><b>To prevent antenna damage, take it off before the vehicle enters a vehicle cleaning station for cleaning.</b></p> <p><b>When the vehicle is parked in a garage, take the antenna off if it touches the ceiling.</b></p>

## CD player

In loading CD discs, please keep the surface with the label upward. The CD players will play the files in the CD from the first to the last and then replay the cycle.

Notice
<p><b>Do not disassemble the CD player without permission. Do not let oil or other objects enter the CD player.</b></p>

Please use 12cm (4.7 inch) standard CD discs.

## CD player protection

- The CD player is designed specially for 12cm CD discs.
- In extremely hot environment, do not use the CD player. In summer whether, please turn on the air conditioner after CD disc playing.
- When the vehicle is driving on a uneven road, the CD player, if working, may have the noise jump problem.
- If there is moist in the CD player, no song can be heard even when it is working. You should take the CD disc out of the player and not use the CD player until it is dry.

### Friendly Tips

**The CD player adopts invisible laser, which, if radiating out of the CD player, may lead to irradiation hazard. Please operate the CD player correctly according to the instruction.**



- Only standard CD discs as the above figure shows can be played.
- Possibly, following CD discs cannot be played:

Anti-copy CD  
 CD-R  
 CD-RW  
 CD-ROM

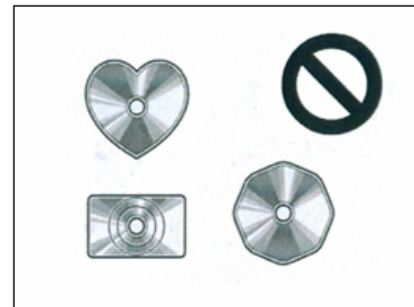

Discs with special shapes

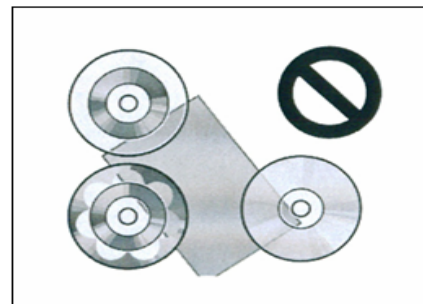

Transparent and translucent discs

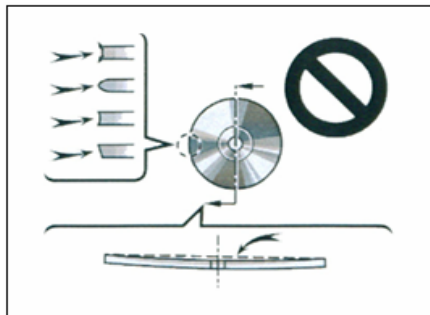

Discs of poor quality

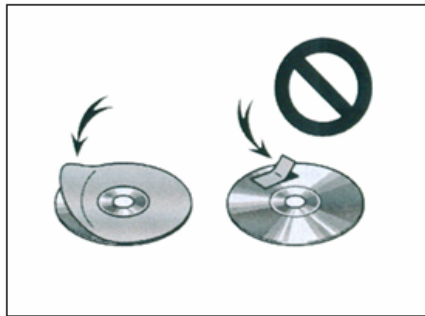

Discs with labels

**Notice**

**Please play legal discs. Do not use special-shape, transparent, translucent, poor-quality or labeled discs as shown above; otherwise, the CD player may be damaged or the disc cannot be played.**

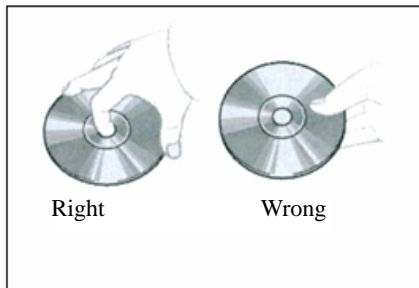

- CD discs should be loaded and unloaded carefully. More care should be taken for inserting a disc into the CD player slot. Hold edge of the disc and do not twist it. Do not leave your fingerprints on the CD disc, especially the data storage surface.

- Filth, scratches, contortion, pin holes or other damages on the disc may lead to skip reading or track repeat.

- After listened to, the CD disc should be taken out from the player and put into a plastic box away from moisture, heat resources and direct solar irradiation.



CD disc cleaning: first wipe the CD disc surface with a piece of soft and velveteen-free wet cloth and then wipe it dry with dry soft cloth. Do not apply alcohol or other detergent.

**Section 1-8****Operation of Instruments and Controllers****8. Air conditioning system**

Air conditioning control panel .....	60
Air outlet mode settings .....	63
Operation instructions .....	65
Side air outlets.....	65
Air filter (optional).....	66

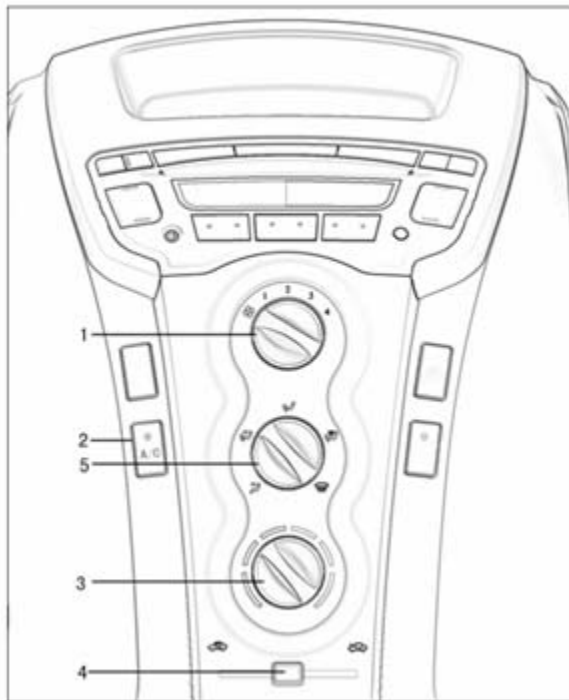
**Air conditioning control panel****With air conditioning**

1. air blower speed regulation knob
2. “A/C” switch
3. cool/hot wind selection knob
4. inner-outer circulation mode selection slider
5. outlet mode selection knob

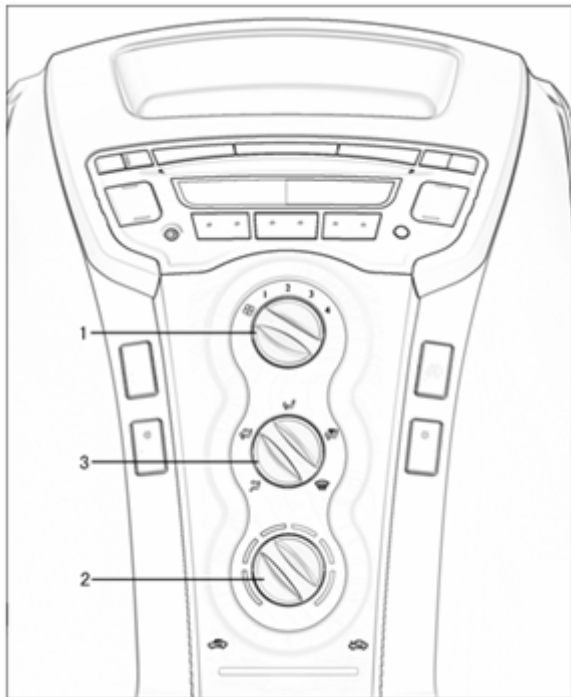
**Without air conditioning**

1. air blower speed regulation knob
2. cool/hot wind selection knob
3. outlet mode selection knob



## (1) Air blower speed regulation knob

Turn this knob to regulate the fan speed of the air blower—clockwise to increase the wind speed and anticlockwise to decrease the wind speed.

## (2) Cool/hot wind selection knob

Turn this knob to adjust the temperature—clockwise for increase and anticlockwise for decrease.

## (3) Outlet mode selection knob

Turn this knob to adjust the direction of the gas flow outlet.



1) Instrument panel—air flows come mainly from the air vents of the instrument panel.

2) Double layer—air flows come mainly from air vents of the floor and the instrument panel.

3) Floor—air flows come mainly from air vents of the floor.

4) Floor/windshield—air flows come mainly from air vents of the floor and the windshield.

It is used together with the inner-outer circulation mode selection slider in the outer circulation position.

5) Windshield—air flows come mainly from air vents of the windshield. It is used together with the inner-outer circulation mode selection slider in the outer circulation position.

For settings of the outlet mode selection knob, refer to the “—outlet mode settings” introduced below.

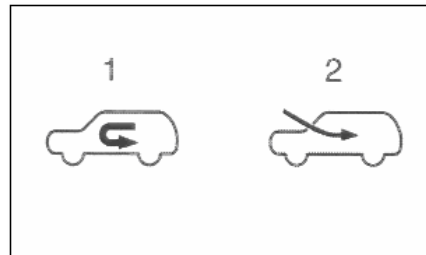

## (4) Inner-outer circulation mode selection slider (with air conditioner)



1) Inner circulation—to re-circulate air in the vehicle.

2) Outer circulation—to introduce outside air in the vehicle.

## (5) “A/C” switch

To turn on the air conditioning system, first turn the air blower speed regulation knob to a position other than “” and then press the “A/C” switch. At the same time, the working indicator of the switch will shine. Press the “A/C” switch again or turn the air blower speed regulation knob to position “” to turn off the air conditioning system.

Air outlet mode settings

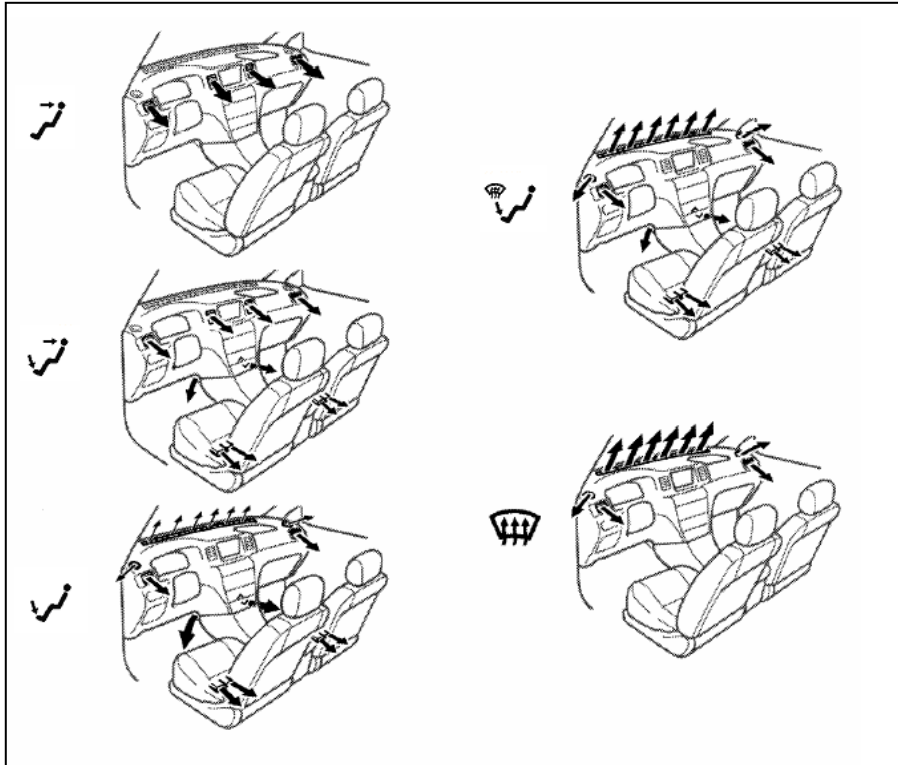

(1) Hot wind

To get the best effect, set the controller as follows:

1) With air conditioning

**air blower speed**—any position other than “”

**temperature**—heating position (red region)

**air introduction**—outer circulation (outside air)

**air flow**—floor

**air conditioner**—off

For fast temperature rise, select the inner circulation mode and keep it for minutes. Then, to prevent mist accumulation on the windows, select the outer circulation mode after the temperature in the vehicle is increased to a certain level.

- Press the “A/C” to remove moisture brought by heating.
- Select floor/windshield mode air flows to heat the vehicle interior and

remove frost and fog of the windshields.

## 2) Without air conditioning

**air blower speed**—any position other than “”  
**temperature**—heating position (red region)  
**air flow**—floor

## (2) Cooling (with air conditioning)

To get the best effect, set the controller as follows:

**air blower speed**—any position other than “”  
**temperature**—cooling position (blue region)  
**air introduction**—outer circulation (outside air)  
**air flow**—instrument panel  
**air conditioner**—on

- For fast temperature decrease, select the inner circulation mode and keep it for minutes.

## (3) Ventilation (with air conditioning)

To get the best effect, set the controller as follows:

**air blower speed**—any position other than “”  
**temperature**—cooling position (blue region)  
**circulation mode**—outer circulation (outside air)  
**outlet mode**—face blowing  
**AC switch**—off

## (4) Defogging (with air conditioning)

Interior of the front windshield  
 Optimized settings

**air blower speed**—any position other than “”  
**temperature regulation**—heating (red regions); cooling (blue region)  
**circulation mode**—outer circulation (outside air)  
**outlet mode**—defogging  
**AC switch**—on

- In damp weather, do not blow the windshield with cold wind; otherwise, more fog will be produced on the windshield due to inside-outside temperature difference.

## (5) Defrosting

Exterior of windshields  
 Optimized settings:

## 1) With air conditioning

**air blower speed**—any position other than “”

**temperature regulation**—heating (red regions)

**circulation mode**—outer circulation (outside air)

**outlet mode**—defrosting

**AC switch**—off

## 2) Without air conditioning

**air blower speed**—any position other than “”

**temperature regulation**—heating (red regions)

**outlet mode**—defrosting

● To defrost windshields by increasing the temperature in the vehicle, the outlet mode should be selected as feet-blowing defrosting.

**Operation instructions**

1) To cool the vehicle fast after it has been parked under direct solar irradiation, you can drive for a few minutes with the windows opened and, after the hot air has been discharged, close the windows and turn on the air conditioning system to cool the interior.

2) Make sure the air inlet grilles in front of the front windshield are not obstructed (by leaves, accumulated snow, etc.).

3) In damp weather, do not blow the windshield with cold wind; otherwise, more fog will be produced on the windshield due to inside-outside temperature difference.

4) Keep air ventilation below the front seat so that air in the vehicle can be thoroughly circulated out.

5) In chilly weather, the fan speed should be increased and kept for 1min to remove accumulated snow or moisture in the air inlet pipe and reduce fog on the windows.

6) With air conditioning: In driving on dusty roads, all windows should be closed.

If dust produced by vehicle driving can still enter the vehicle even when all windows are closed, it's best to move the inner-outer circulation mode slider to the outer circulation mode and turn the air blower speed regulation knob to a position other

than “”.

7) With air conditioning: On dusty roads or in windy or dusty weather, if you drives following another vehicle, it's best to move the inner-outer circulation mode slider to the inner circulation mode to cut off the air passage to the outside so as to prevent outside air and dust from entering the vehicle.

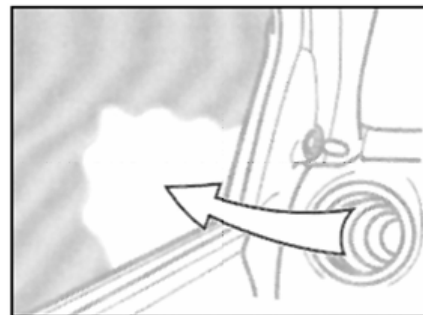
**Side air outlets**

Tips: Turning the front side outlet to the front door window can defrost the front door window quickly.

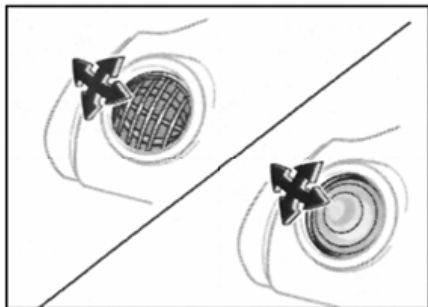

If the air flow is not satisfactory, check side air outlets. Side air outlets can be opened or closed as the above figure shows.

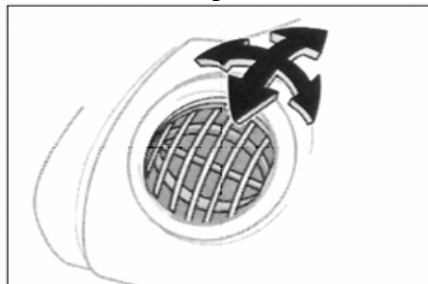

You can change the air flow direction by turning the side air outlet.

### Air filter (optional)

The air filter is equipped under the instrument table and in front of the co-driver seat.

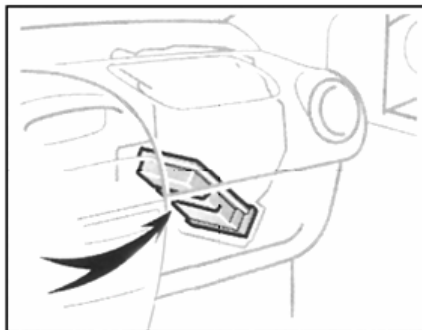

### Air filter examination and replacement

After long-time use, the air filter may be obstructed. According to experience, when the efficiency of air flowing, heating or defrosting is significantly reduced or door windows are prone to fog up, the air filter should be replaced.

To keep the air conditioning efficiency, check and replace the air filter according to the following maintenance method.

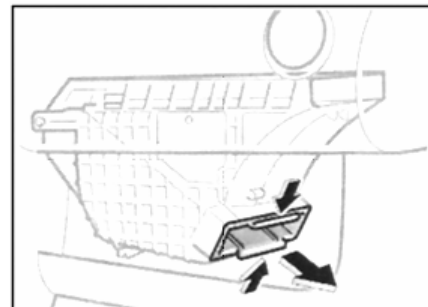

- 1) Take the air filter out according to the illustration.
- 2) Check the filter surface.

If the surface is not clean, the filter should be replaced.

#### Notice

**The air filter should be mounted in the correct position. If the air filter is not installed, the anti-dust and air conditioning performance may be affected.**

**Section 1-9****Operation of Instruments and Controllers****9. Other devices**

Electronic clock .....	68
Cigarette lighter (optional).....	68
Cup holder.....	68
Rear rack .....	68

## Electronic clock

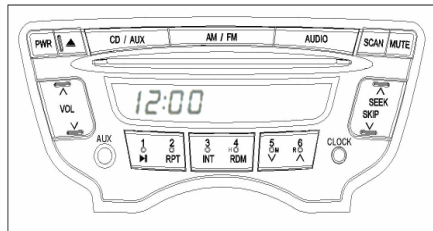

The key should be in position “I” or “II” .

Hold the CLOCK button for 2s to enter the clock adjustment interface. Press “4(H)”, “5(M)” and “6(R)” respectively for hour, minute adjustment and minute zero-return.

## Cigarette lighter (optional)



The cigarette lighter is a device used for light cigarette of the driver or a passenger. For use, press the cigarette lighter plug and, after it rebounds, take it out to light the cigarette.

Only when the ignition key is in position “I” or “II” can the cigarette lighter be used.

### Notice

**Do not press the cigarette lighter for long time.**

**After the cigarette lighter plug is heated, avoid contacting the metal part of the plug.**

**Except the cigarette light plug, do not put other metal articles or objects in the cigarette lighter socket; otherwise, short circuit may be caused.**

**If the cigarette light is to be replaced, BYD specified substitutes should be used.**

## Cup holder

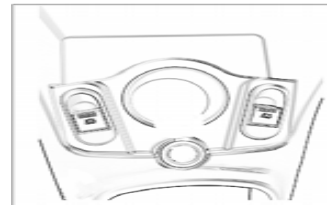

The cup holder is used for placing a cup or drink tin in. The cup dimension should not exceed 60mm×100mm.

## Rear rack



When the rear back door is opened, the rear rack will slope upward so that baggage can be placed in or taken out easily.

When additional baggage space is needed, take the rope away and raise the rack from the fixer.

Make sure the rack is arranged correctly.

**Section 2****Chapter 2 Driving Tips**

Running-in period .....	70
Fuel .....	70
Fuel cut-off system.....	70
Three-way catalytic converter.....	71
Engine exhaust warning .....	72
Engine oil .....	72
Brake system.....	73
Brake lining warning piece .....	75
Considerations for baggage loading.....	75
Suspension and chassis .....	75



## Running-in period

**Drive steadily and do not drive at high speeds.**

The vehicle needs no very complex adaptation. However, observance of the following simple instructions during the first 2,000km (kilometer) can not only save fuel but also lengthen the service life of the vehicle:

- Avoid full throttle in starting and driving.
- Avoid over-speed engine operation.
- Avoid emergency braking in the first 300km (kilometer).
- Do not drive too fast or too slowly at a constant speed.€
- Do not haul trailers in the first 2,000km (kilometer).

## Fuel

**Correct fuel selection is the basis for taking full use of the engine performance. Application of fuel adapting to EOBD is also critical to exhaust control and maintenance of relevant parts.**

Engine damage or discharge disqualification due to use of improper fuel is not included in the guarantee range of BYF F0 Auto.

## Fuel types

**Only No. 93 (included) or above lead-free gasoline conforming to National III or IV standard can be used.**

To prevent incorrect gasoline feed in gas stations, the vehicle is equipped with a small fuel tank opening, which matches the special nozzle of lead-free gasoline refueling pumps and doesn't adapt to the large standard nozzle of leaded gasoline refueling pumps.

### Notice

◆ **Do not use leaded gasoline. Application of leaded may lead to invalidity of the three-way catalyst converter and the exhaust pollution control device and increase the maintenance and repair cost.**

### Notice

◆ **Only No. 93 or above lead-free gasoline conforming to National IV standard can be used for EOBD.**

## In case of engine detonation

Under application of the recommended fuel, if severe detonation is felt or regular detonation sounds are heard when the vehicle is driving on even roads, you should contact a BYD authorized service station. However, you can occasionally hear short and slight detonation sound when accelerating or climbing slopes. It's normal and you need not to worry about it.

## Fuel tank capacity

30L (liter)

## Fuel cut-off system

In accidents, when the engine stops, the engine control system will stop providing fuel for the engine so as to lower the fuel leakage risk to the minimum. After the fuel pump stops, to restart the engine, turn the ignition switch to "I" or "0" and then restart it.

### Friendly Tips

- Before restarting the engine, you should check the ground under the vehicle to see whether there is any fuel leakage. If there is, the fuel system must have damages and requires repairing. In case of such problems, do not restart the engine.

### Three-way catalytic converter

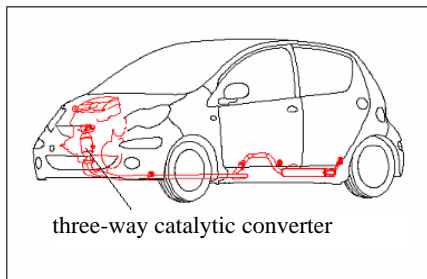

The three-way catalytic converter is an exhaust purifying device mounted in the exhaust system. It is used for reducing pollutants in the exhaust.

### Friendly Tips

- During engine operation, people and inflammables should be kept far away from the exhaust pipe, since the exhaust is extremely hot.
- Do not drive, idle or park the vehicle on the ground where there are weeds, leaves, paper or cloth which may cause fires.

### Notice

Too much un-burnt gas flowing into the three-way catalytic converter may lead to overheat of the device and, possibly, fire disasters. To prevent such and other dangers, you should take abide by the following instructions:

- ◆ Use lead-free gasoline only.
- ◆ Do not drive when the fuel level is very low; operation with fuel insufficiency may lead to engine misfire and increase the load of the three-way catalytic converter.

- ◆ Do not idle the engine at high or low speeds for long.
- ◆ Avoid over-speed engine operation.
- ◆ Do not start the vehicle by pushing or pulling it.
- ◆ Do not turn off the ignition switch when the vehicle is driving.
- ◆ Keep the engine in good operation state; malfunction of the electrical system, the electronic ignition system or the fuel system of the engine will lead to abnormally high temperature of the three-way catalytic converter.
- ◆ If the engine is difficult to start or frequently stops, check the vehicle immediately.
- ◆ To ensure normal operation of the three-way catalytic converter and the whole exhaust pollutant control device, the vehicle should be examined periodically according to the BYD F0 maintenance plan. (refer to Section 6)

## Engine exhaust warning

### Friendly Tips

- Avoiding inhaling the engine exhaust.
- Make sure the exhaust system has no leakage holes and the conjunction is tight. Check the exhaust system regularly. If you a crash accident happens or the exhaust sound changes, check the exhaust system immediately.
- Except entering or leaving the garage, do not start the engine in the garage or in closed spaces. Exhaust accumulated may cause severe dangers.
- Do not park the vehicle for long time with the engine running. However, if you have to do that, park the vehicle in an open place and adjust the heating or cooling system to introduce outside air into the vehicle.
- The rear back door should be closed during driving. The exhaust may come into the vehicle from the rear back door if it is open or loosely closed.
- The air inlet grille in front of the

windshield should be free of accumulated snow, leaves or other obstructions to ensure normal work of the ventilation system of the vehicle.

- If exhaust can be smelt in the vehicle, open the windows and immediately check the exhaust introduction sites to solve the problem.

## Engine oil

### Function of engine oil

The engine oil functions mainly for lubricating and cooling the engine interior and also plays a key role in keeping the engine in normal work state.

**In normal work, the engine will consume some engine oil. Under normal conditions, the engine consumes engine oil for the following reasons:**

- The engine oil is used for lubricating the piston, the piston ring and the cylinder. When the piston moves downward in the cylinder, a layer of thin oil film will be produced on the cylinder wall.
- When the vehicle slows down, the

produced high negative pressure will draw some oil into the combustion chamber. The oil, like part of the oil film on the cylinder wall, can be burnt by the high-temperature burning gas.

The engine oil is also applied for lubricating the inlet valve stem. Some oil will be drawn into the combustion chamber and burnt with the fuel. High temperature exhaust can also burn engine oil used for lubricating the vent stem.

**The engine oil consumption is related to its viscosity, quality and the driving vehicle status.**

High-speed driving and frequent acceleration and deceleration can increase the engine oil consumption.

Piston, piston ring and cylinder wall of the new engine in the running-up period will consume more engine oil.

**It should be noted that, in engine oil consumption evaluation, it' s difficult to judge the oil level correctly since the engine oil becomes diluted.**

For example, the vehicle has driven for a plurality of short trips and consumed the normal engine oil, but the engine oil level

showed by the oil meter never decreases even 1,000km (kilometer) or longer has been run because the engine oil has been slowly diluted by the fuel and its vapor.

In high-speed driving, on an expressway for example, the diluted parts will be evaporated, so afterward, you may find that much engine oil has been consumed.

### Importance of engine oil level examination

It's one of the key points in regular vehicle maintenance to keep the engine oil level above the optimal oil level so that the engine oil function won't be reduced. Therefore, it's very important to check the engine oil regularly. We suggest you check the engine oil level each time you add the oil.

#### Notice

- ◆ **If the engine oil level is not checked regularly, engine oil insufficiency may lead to severe engine faults.**

For details on engine oil level examination, refer to "Examine the engine oil level" in

Section 7-2.

### Brake system

The brake system is a hydraulic system with two independent auxiliary brake systems. Even if one auxiliary brake system becomes invalid, the other can still function, but more effort is needed to press the brake pedal and the brake distance will also be lengthened.

#### Friendly Tips

- **Do not drive the vehicle with only one auxiliary brake system working. The invalid auxiliary system should be repaired soon.**

### Vacuum booster

The vacuum booster works with the air inlet negative pressure of the engine. If the engine stops when the vehicle is driving, you can stop by pressing the brake pedal with much more effort than usual.

#### Friendly Tips

- **Do not press the brake pedal repeatedly if the engine stalls since the vacuum pressure may be consumed.**
- **Even if the vacuum power is totally consumed, the brake can also work, but the brake pedal should be pressed with much more effort than usual and the brake distance will also be lengthened.**

**Anti-lock brake system (with "ABS" warning light)**

**The anti-lock brake system is used for preventing lock of wheels in emergency braking or braking on slippery roads. It is helpful for providing stable direction control and vehicle steering performance.**

The effective method to press the ABS brake pedal: When the ABS system works, you will feel pulses of the brake pedal and hear noises. Under such conditions, as long as you press the brake pedal hard, the anti-lock brake system will work. In

emergency braking, do not press the brake repeatedly; this will lengthen the brake distance.

When the vehicle speed is increased to over 5 km/h (kilometer/hour), the anti-lock brake system enters work state. When the speed is reduced to below 5km/h (kilometer/hour), the anti-lock brake system will stop working.

In rainy whether, pressing the brake pedal can easily activate the anti-lock brake system on slippery roads, e.g. manhole covers, steel plates, bridge ends, etc.

When the engine is starting or the vehicle has just begun driving, you may hear clicking sounds in the engine compartment or motor sound persisting for seconds. This means the anti-lock brake system is performing self-check and doesn't indicate problem existence.

**When the anti-lock brake system is working, the following phenomena may occur, but this doesn't indicate that the system has faults:**

- You can hear the working sound of the anti-lock brake system and feel the pulses of the brake pedal and vibration of the vehicle body and the steering wheel. Even after the vehicle has stopped, you can still hear motor

sound sent out from the engine compartment.

- When the anti-lock brake system is ending its work, the brake pedal may move forward a little.

#### Friendly Tips

- **Do not think too highly of the anti-lock brake system; though it can help with the vehicle control, it's still very important to follow all regulations and keep a proper driving speed and safety distance, since even when the anti-lock brake system functions, its effect of stabilizing the vehicle is limited.**

- **In driving in rainy whether, if the anti-skid performance of the tires exceeds the allowance or wheel spin occurs, the anti-lock brake system will lose its effect of vehicle control.**

#### Notice

**The anti-lock brake system is not used for shortening the brake distance, so you should drive at proper speeds with the safety distance kept with the preceding vehicle. Under the following conditions, longer brake distances may be required compared with vehicles without the anti-lock brake system:**

- Driving on uneven, pebble-laid or snow-covered roads.
- Driving with wheel antiskid chains equipped.
- Driving on steps connecting roads.
- Driving on roads with recessions and projections.

**All of the four wheels are equipped with specifically-sized tires with proper pressure: the anti-lock brake system tests the vehicle speed with a speed sensor to get the rotating speed of each wheel. If tires not of the specified sizes are used, the rotation speeds cannot be determined accurately, leading to increase of the brake distance.**

## Drum parking brake

The vehicle is equipped with a drum parking brake. Brake shoes of such brake systems should be ran in regularly or after the brake drum or the brake shoes are replaced.

Please have the running-in work done in a BYD authorized service station.

## Brake lining warning piece

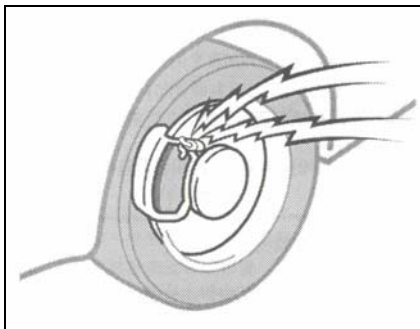

The brake warning piece on the disc brake will send out warning sound when the brake lining is worn and requires replacing.

If you hear screams or friction noise in driving, immediately contact a BYD authorized service station to have the vehicle checked.

Do not continue driving the vehicle if you hear the warning alarm.

## Considerations for baggage loading

You should follow the instructions below when loading baggage or goods:

- Put the baggage or goods in the trunk as far as possible. Make sure all things are fixed firm.
- Keep the vehicle balanced. Put heavy things in the front to keep balance.
- To save fuel, do not load unnecessary heavy things on the vehicle.

## Suspension and chassis

### Friendly Tips

- Do not modify the suspension/chassis with lifting tools, distance pieces, springs, etc. This may do harm to the manipulation performance and cause control loss.

## Section 3

### Chapter 3 Starting and Driving

Before starting the engine .....	77
Engine starting methods .....	77
Safety examinations before driving .....	77
Driving tips under different conditions .....	79
Driving tips in winter .....	79
Trailer towing.....	80
How to save fuel and prolong the vehicle service life .....	81

## Before starting the engine

1. Before entering the vehicle, check the surrounding environment.
2. Adjust the seat position, the seat height, the backrest angle, the height of the head protection device and the angle of the steering wheel.
3. Adjust the internal and exterior rearview mirrors.
4. Lock all the doors.
5. Fasten the seat belt well.

## Engine starting methods

### (a) Before starting

1. Put down the parking brake.
2. Turn off all unnecessary lights and auxiliary devices.
3. Set the shift bar at the neutral gear.
4. Press the clutch pedal to the bottom and do not release it until the vehicle is started.

### (b) Engine starting

Before starting the engine, make sure the work described in “(a) before starting” has been done.

#### Normal starting procedures

The multi-point fuel injection system in the

engine will automatically control the mixture of air and fuel used for starting. You can perform cold or hot engine start according to the following procedures.

Turn the key to position “III” to start the engine. After the engine is started, release the key.

Then engine can heat up by driving rather than by running idle. Steadily run the engine to pre-heat the driving vehicle until the temperature of the engine coolant rises to the normal range.

#### If the engine stalls

Start it again according to the normal starting procedures.

#### If the engine can not start

Refer to “If the vehicle cannot be started” in Section

#### Notice

- ◆ **The engine starting attempt should be finished within 3 seconds; otherwise, it may lead to overheat of the starter and the wire system.**

- ◆ **Avoid over-speed running of the engine.**

- ◆ **If the engine is difficult to start or always stalls, it should be examined immediately.**

## Safety examinations before driving

Before starting, it's best to examine the vehicle carefully. It takes only minutes but will bring you driving safety and enjoyment. As long as you have a basic knowledge of each part, you can examine the vehicle. Alternatively, you can ask a BYD authorized service station to examine it for you.

#### Friendly Tips

- **If the examination is done in a closed garage, make sure the garage is well ventilated. The engine exhaust is poisonous.**



**(a) Examinations before starting the engine****Vehicle exterior**

1. **Tires:** Determine the tire pressure with a tire pressure gauge and check them carefully to see whether there is any cut, damage or over wear.
2. **Wheel bolts:** Make sure the bolts are not loose or lost.
3. **Leakage:** After the vehicle has been parked for a while, check whether there is any fuel, engine oil, water or other liquid leakage on the ground. (It's normal that there are water drops produced by the air conditioning system.)
4. **Lighting:** Make sure head lights, parking lights, small lights, turn signal lights and other lighting devices can all work normally. Check the light intensity of the head lights.

**Vehicle interior**

1. **Spare tire, jack and wheel bolt wrench:** Check the tire pressure and make sure the vehicle is provided with a jack and a wheel bolt wrench.

2. **Seat belt:** Check whether the buckle can be fastened firm. Make sure the seat belt is not worn or scraped.
3. **Instruments and controllers:** Specifically, make sure the maintenance indicators, instrument lighting and defrosters can work normally.
4. **Brake:** Make sure there is enough free clearance for the pedal.

**Engine compartment interior**

1. **Spare fuses:** Make sure spare fuses of different rated amperage are provided in the fuse box.
2. **Coolant level:** Make sure the coolant level is correct. (refer to instructions in Section 7-2)
3. **Battery and cable:** Check whether the battery connectors are corroded or loose, whether the box has cracks and whether the cables are well connected.
4. **Wires:** Check whether there are broken, loosened or disconnected wires.
5. **Fuel pipe:** Check whether the pipeline has leakage or loose connection.

**(b) After the engine is started**

**Exhaust system:** Check whether there is gas leakage by listening. If any, repair the exhaust system immediately. (Refer to “Engine exhaust warning” in Section 2)

**Engine oil level:** Stop the engine and park the vehicle on the flat ground. After a few minutes, determine the engine oil level with an oil measuring meter. (Refer to instruction in Section 7-2)

**(c) In driving**

**Instruments:** Make sure the maintenance indicators and the speedometer work normally.

**Brake:** Check the brake in a safe place and make sure it doesn't deflect to any direction in braking.

**Examination of other abnormalities:** Check to see whether there are loose parts and leakage; listen to see whether there are abnormal noises.

## Driving tips under different conditions

- When driving against the wind, you should drive slowly so that the vehicle can be controlled easily.
- On trim-stones of road sides, you should drive slowly and keep the right angle as far as possible. Avoid driving on high and sharp objects or other road obstacles; otherwise, severe tire damages, e.g. explosion, may be caused.
- Reduce the speed when driving on uneven roads; otherwise, the impact will severely damage the tires and wheels.
- The brakes will be wetted in cleaning the vehicle or driving through deep water. You can check whether they are wetted by pressing the brake pedal lightly. Before the check, you should first make sure it is safe. If you cannot feel the normal brake force, the brakes may have been wetted. To dry them, you can, with the parking brake used, drive carefully and lightly press the brake pedal.

### Friendly Tips

- Before driving, make sure the parking brake is thoroughly released and the parking brake indicator is out.
- When the engine is working, do not leave the vehicle.
- Do not place your foot on the brake pedal in driving; it may lead to over-heat and wear of the brake and fuel waste.
- When going down a long steep slope, you should reduce the speed and turn to a low-speed gear. Frequent brake manipulation will lead to over-heat and, possibly, performance faults.
- Care should be taken in accelerating, high gear shift, low gear shift or braking on slippery roads. Sudden acceleration or engine brake will lead to vehicle sliding or turning.
- Do not drive if the brakes are moistened. When the brakes are moistened, longer brake distances are needed, and, the vehicle may be hauled to one side when the brakes

are used. Similarly, the parking brake cannot park the vehicle firm either.

### Notice

- ◆ Avoid accumulated water when driving on wet roads. Too much water introduced into the engine compartment may cause damage to the engine and electrical parts.

## Driving tips in winter

**Make sure the coolant has proper anti-freezing protection effect.**

Only coolants specified by BYD authorized service stations can be applied. You should select proper coolant according to the environment temperature and add it into the cooling system.

Application of unsuitable coolants will damage the engine cooling system.

<b>Notice</b>
---------------

◆ <b>Do not use water..</b>
-----------------------------

**Check the battery and the cable.**

Energy of all batteries can be reduced by cold whether, so the battery shall have sufficient power for starting in winter. Section 7-3 introduces battery examination by eye. BYD authorized service stations can examine the charging status of the battery for you.

**Make sure the engine oil viscosity is suitable for driving in winter.**

Refer to Section 7-2 for recommended engine oil viscosity. Too much summer-use engine oil remaining in the engine will lead to starting difficulty in winter. If you are not sure which engine oil should be used, you can seek help in any BYD authorized service station.

**Protect door locks from being frozen by ice or snow.**

Inject some deicer or glycerin into the door lock holes to prevent freezing.

**Apply cleaning liquids containing anti-freezing agents.**

Such products are available in BYD authorized service stations. The anti-freezing agent should be mixed with water according to instructions of the manufacturer.

<b>Notice</b>
---------------

◆ <b>Do not use the engine anti-freezing agent or other substitutes as the cleaning liquid, since it may damage the vehicle paint.</b>
--

**Do not use the parking brake if it may be frozen.**

For parking, set the gear lever in the neutral gear and block up the rear wheels. Avoid using the parking brake; otherwise, its periphery may be frozen by accumulated water or snow, causing it difficult to release.

**Make sure there is no accumulated snow or ice under the dashboard.**

Accumulated snow or ice under the dashboard may lead to turning difficulty. In freezing winter, you should stop often to see whether there is any accumulated ice or snow under the dashboard.

**It is suggested you carry some necessary tools for emergent use according to the road conditions.**

It's best you have a tire chain, a window scraper, a bag of sand or salt, a signal flashing device, a small shovel, connecting cables, etc. in the vehicle.

**Trailer towing**

BYD F0 is designed mainly for transporting passengers. Towing trailers will exert adverse influence on operation, performance, brake, durability and economical driving (fuel consumption, etc.) Safety and comfort of driving are totally dependent on correct use of the instruments and a good driving habit. For your own and others' safety, do not overload the vehicle or use it to haul trailers. BYD won't take responsibilities for damage or faults caused by trailing with commercial purposes.

### Weight limit

Before towing a trailer, the towing capacity of the trailer should be confirmed. You can contact a local BYD authorized service center and make sure that the towing capacity of the trailer is within the regulated range.

The towing capacity is determined on a flat road surface. It should be remembered that in mountainous regions, the engine power and its towing capacity will be reduced.

#### Friendly Tips

- **The hauled trailer weight should not exceed the maximum rated weight of the towing hook; otherwise, accidents and severe human damage may be caused.**
- **Towing may increase the brake distance, so in trailer towing, the safety distance should be lengthened. At a speed of 10km/h (kilometer/hour), the distance between your vehicle and the preceding vehicle should be at least the sum of the lengths of your vehicle**

**and the trailer. Avoid emergency braking; otherwise slipping may cause vehicle folding and make the vehicle out of control.**

### Tires

- Make sure the tires have proper pressure. Refer to instructions in Section 7-2.
- Keep the trailer tire pressure at the pressure strength defined by the trailer manufacturer according to the total weight of the trailer.

### Running-in procedures

- BYD Company suggests that all new vehicles or vehicles with new parts (engine, speed reducer, differential, wheel bearing, transmission shaft, etc.) not haul trailers in the first 2,000km (kilometer).

### Maintenance

- Trailer towing will increase the load of the vehicle, so it should be maintained more frequently.

### How to save fuel and prolong the vehicle service life

Fuel consumption can be reduced easily and conveniently. It can also lengthen the service life of the vehicle. Following is some knowledge on reducing the fuel and repair expenditure:

- **Keep proper tire pressure.** Tire pressure insufficiency will lead to tire wear and increase the fuel consumption. Refer to instruction in Section 7-2.
- **Do not place unnecessary things on the vehicle.** Too heavy weight will increase the engine load and lead to fuel consumption increase.
- **Avoid long-time pre-heating idling.** Once the engine has entered steady state, you can start driving, but the operation should be steady. It should be noted that in cold weather, the longer time is needed to preheat the engine.
- **Accelerate slowly and steadily.** Avoid sudden start. Drive with high-speed gear shifts soon.
- **Avoid long-time engine idling.** To wait for others when the traffic is not busy, you'd better stop the engine and, after the people have come, start it again.

- **Avoid lug down or over-speed operation of the engine.** Select proper speed gear shifts according to the road conditions.
- **Avoid frequent acceleration and deceleration.** It may increase the fuel consumption.
- **Avoid unnecessary parking or braking.** Keep a steady speed. Driving in accordance with the traffic signal lights can reduce the stop times to the minimum. Alternatively, drive on free roads with no traffic lights with a proper distance kept from the preceding vehicle to avoid emergency braking. This can also reduce brake wear.
- **Avoid areas with busy traffic or congestion as far as possible.**
- **Do not place your foot on the clutch**

**pedal or the brake pedal.** This may produce early wear and over heat and consume large amounts of oil.

- **Position the front wheels** correctly. Avoid crushing into stones on road sides. Drive slowly on uneven roads. Improper front wheel location can not only lead to over wear of tires, but also increase the engine load and fuel consumption.

- **The chassis should be kept clean and free of mud.** This can not only reduce the vehicle weight but also prevent corrosion.

- **Adjust the vehicle to keep it in the optimal state.** Dirty air filter, improper air vane, dirty spark plug, dirty engine oil and lubricant, improperly adjusted brakes, etc. can all affect the engine performance and cause fuel waste. To prolong their useful

lives, all parts should be maintained regularly. If you often drive in harsh environments, the vehicle should be maintained more often (refer to Section 6).

#### Friendly Tips

- **Do not stop the engine when going down slopes. If the engine is stopped, the power steering system and the vacuum booster won't function. Similarly, only when the engine is working can the exhaust pollutant control device can work properly.**

## **Section 4**

### Chapter 4 Emergency Handling

The car can not start up .....	84
The engine shut down while driving .....	86
The car is overheated .....	87
The car has flat tires .....	88
If the car gets stuck .....	92
The car needs towing .....	92

## The car can not start up

### (a) Simple Check

First please make sure that you are trying to start the car according to "Starting Method for Engine" of Section 3. Then, check whether there is plenty of fuel, and whether the spare key can start the engine. If the spare key can start it, that means the master key may have been damaged and please contact the service store authorized by BYD for test. If no key can start up the vehicle, probably there is something wrong with the engine system, and please contact the service store authorized by BYD for repair (see "Key" of Section 1~2).

### If the engine can not run or run too slowly,

1. Check whether the battery connectors are tightened and clean.
2. If the battery connectors are not the problem, please turn on the reading light:
  - If the reading light can not be lit up or with dim light, or the battery power run out during the engine is starting up, you can try a jump start. Please

see "(c) Jump Start".

- If the reading light is lit up but the engine can not start up, please contact the service store authorized by BYD.

Notice
<p><b>Do not try to manage it by pulling or pushing the car, otherwise there may be damage to the car or crash when the engine starts up, and meanwhile three-way catalytic converter may get overheated to start a fire, resulting in a fire.</b></p>

### If the starter motor of the engine runs at the normal speed but can not start the engine,

Rotate the ignition key to "I" or "0" and try again to start the engine.

If the engine can not start up, maybe there is fuel spilled as a result of repeated starting. Please see "(b) Fuel Spill in Engine Starting" for more details.

If the engine still can not be started, please contact the service store authorized by BYD.

### (b) Fuel Spill in Engine Starting

**If the engine can not start up, maybe there is fuel spilled as a result of repeated starting.**

In this case, please step on the accelerator pedal in full force and meanwhile rotate the key to "III". Keep the key and accelerator pedal in place for 15 seconds, and then release them for another try of starting with your feet off the accelerator pedal.

If the engine still can not start up after the 15 seconds, please release the key, and try starting once again several minutes later.

Now if you still fail to start the engine, please contact the service store authorized by BYD for help.

Notice
<p><b>◆ Each starting attempt should not last more than 30 seconds, or the starter motor and line system may get overheated.</b></p>

**(c) Jump Start**

To avoid personal injury and damage to the car caused by battery explosion, sulphur acid burning, electrical appliances burning, or damaged electronic components, please follow the below instructions.

If you are not sure about these procedures, please ask the service store authorized by BYD for help.

**Friendly Tips**

- The battery containing sulphur acid is toxic and erosive. While starting, please wear safety glasses and protect your skin, clothes, and the car from being touched by sulphur acid leakage.

- If sulphur acid runs onto your body or into your eyes accidentally, please take off the clothes attacked by sulphur acid right away, wash the afflicted part with clean water, and then go to see the doctor quickly. If possible, please continue to scrub the afflicted part by wet sponge or cloth on

the way to clinic.

- If there is flame or sparkle nearby, the gas generated by battery may come into explosion. Please use standard wire for starting and avoid smoking or lighting a match.

**Notice**

- ◆ The battery power for starting is 12V. Before conducting a jump start, please make sure the battery is applicable.

**Procedures of Jump Start**

1. If the backup battery is installed in another car, please make sure there is no contact between two cars. Shut down all the unnecessary lights and auxiliary equipments.
2. Start and run the engine of the car with backup battery for a couple of minutes. That is, step lightly on the accelerator pedal to keep the engine running for minutes at the speed of 2000r/m.

3. Connect starting wires in order of a, b, c, d:

- a) Connect the clamp of anode (red) starting wire and anode terminal ( “+” ) of the depleted battery.
- b) Connect the another clamp of anode (red) starting wire and anode terminal ( “+” ) of the backup battery.

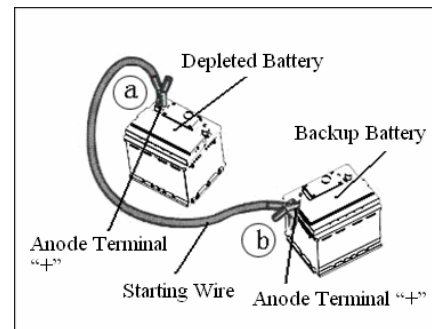



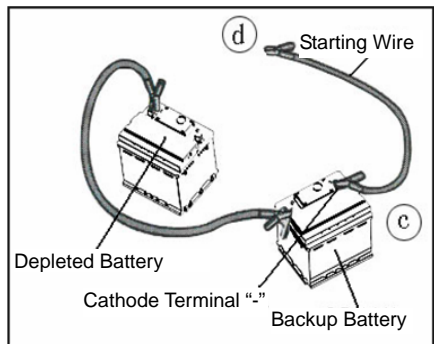

- c) Connect the clamp of cathode (black) starting wire and cathode terminal ( “-” ) of the backup battery.
- d) Connect the another clamp of cathode (black) starting wire to a solid, fixed, unpainted metal fixation point on the power-depleted car.

Below is the joint point:

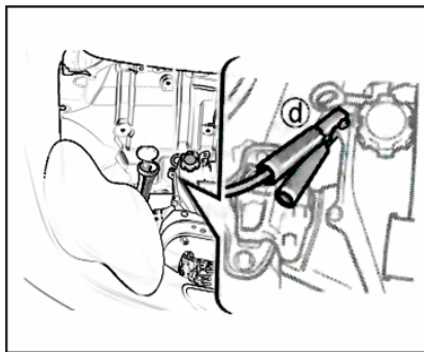

#### Joint Point on the Petrol Engine

When the engine is running, please do not connect the starting wire to any mobile object nearby.

#### Warning

**While connecting, please do not lean the battery or make the starting wire touch any objects except the appointed battery terminal so as to avoid damage.**

4. Start the engine in normal way, and then step lightly on the accelerator

pedal to keep the engine running for several minutes at the speed of 2000r/m.

5. Disconnect the starting wire carefully in completely reversed order: disconnect the cathode starting wire first, and then disconnect the anode starting wire. If the battery power is depleted for reasons unknown, please contact the service store authorized by BYD for examination.

#### If jump start fails

Please check whether the clamp on the starting wire is tightened. If the starting wire is connected properly, please charge the power-depleted battery for minutes and then try again to start the engine in normal way. If the engine still can not start up, please contact the service store authorized by BYD for examination.

#### The engine shut down while driving

1. Please slow down the car slowly, keep moving in a straight way and drive away from the road to a safe place.
2. Turn on the emergency flashlight.
3. Rotate the ignition key to "I" or "0" and try again to start the engine.

If the engine can not be started, please see "The Car Can Not Start Up".

#### Friendly Tips

**If the engine can not run, the power-assisting device of brake and redirector will not work. So steering and braking will be more difficult than usual.**

### The car is overheated

**If the coolant thermometer for the engine indicates overheated, or there is power loss, loud knocking, or noisy bang, that means the engine may be overheated. Please handle it as per the procedures below:**

1. Drive the car away from the road, park it, and turn on the emergency flashlight. Set the transmission in the neutral position, and apply the parking brake. Stop using the air conditioning if it is running.
2. If there is coolant or steam spouting out of the radiator or expansion tank, please shut down the engine until it is cooled down . If no coolant or steam is spouting, just keep the engine running and make sure the cooling fan

is working. If not, please turn off the ignition switch.

#### Friendly Tips

- **To avoid personal injury, please keep the engine hood closed until there is no steam. The spouting of steam or coolant means high pressure.**

3. Check whether there is obvious coolant leakage under the radiator, hose, and the car. The water drop from the air conditioning in use is a normal phenomenon.

#### Friendly Tips

- **When the engine is running, please keep your hands & clothes a certain distance away from the working fan & driving belt of the engine.**

4. If there is coolant leakage, please shut down the engine at once and contact the service store authorized by BYD for help.

5. In case of no obvious leakage, please check the coolant overflow tank. If it is dry, please add coolant to the tank until the level is between two scale marks while the engine is running.

#### Friendly Tips

- **In high temperature, the radiator cap is not allowed to be removed since the spouting high-temperature steam and liquid under pressure may cause serious damage.**

6. When the coolant temperature falls down to the normal level, please check the coolant level in the tank again and add additional coolant if necessary. Great loss of coolant means leakage in the system, please contact the service store authorized by BYD for immediate examination.

### The car has flat tires

1. Please decrease the car speed slowly, keep moving in a straight line, and drive away from the road to a safe place on the firm and flat ground out of busy traffic. Do not park your car on the turnout track of the central highway.
2. Shut down the engine and turn on the emergency flashlight.
3. Apply the parking brake, and set the transmission in the neutral position.
4. All people should go off the car for a place away from traffic.
5. Read the following instructions carefully:

#### Friendly Tips

To reduce the possibility of serious personal injury, please obey the instructions below when you try to lift the car by jack.

- Follow the instructions for jack-up.
- No part of your body is allowed to stay under the car lifted by jack, or

there may be bodily injury.

- When the car is lifted by jack, please do not start or operate the engine.
- Park your car on the firm and flat ground, apply the parking brake tightly and set the transmission in the neutral position. If necessary, lay the chock block under the tire in the diagonal direction of the tire to be replaced.
- Make sure the jack is placed on the right lifting point. To lift the car by a jack not placed properly may damage the car or make the car drop down from the jack and thus cause injuries.
- When the car is supported completely by jack, no one is allowed to stay under the car.
- Jack-up is only for tire replacement purpose.
- When someone is in the car, please do not lift it.
- Do not put any thing on the top

or bottom of the jack while lifting.

- Just lift the car to a height that allows tire removal and replacement.

#### Notice

- ◆ Do not continue to drive the car with flat tire. Even a short drive will damage the tire permanently.

Take out the tools required and spare tire.

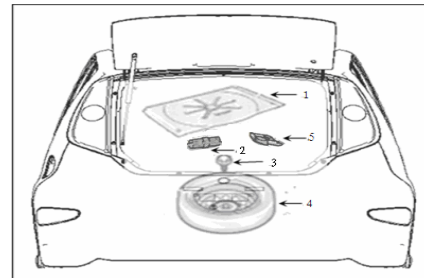

6. Cover Plate for Spare Tire
7. Toolkit
8. Retaining Bolt for Spare Tire
9. Spare Tire
10. Jack

In an emergency, you will need to repair the car by yourself. Please well know the use method and storage site of the jack and its various tools.

### Use your hand to rotate the terminal of the jack

Remove: rotate the terminal in direction 1 until the jack become flexible.

Collect: rotate the terminal in direction 2 until the jack is fixed tightly to avoid it from being thrown forward when there is crash or emergency brake.

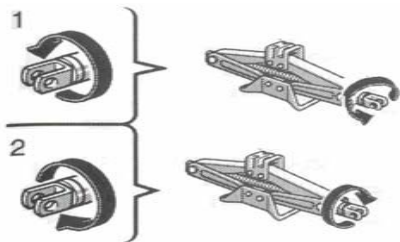

1. Loosen the bolt and remove it, then take the spare tire out of the car.

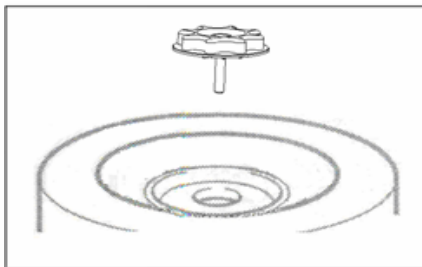

To store the tire, please put the outside of the tire downward, and then fasten the tire in the opposite order above to prevent it from being thrown forward when there is crash or emergency brake.

2. While lifting, please lay the chock block under the tire in the diagonal direction of the flat tire to avoid the car sliding.

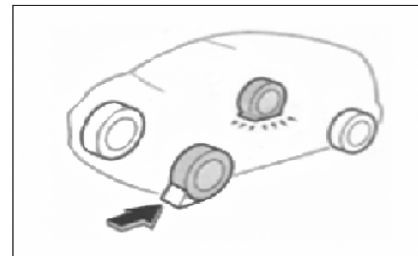

Put the chock block in front of the front tire or behind the back tire.

3. Unscrew all the wheel bolts on the flat tire.

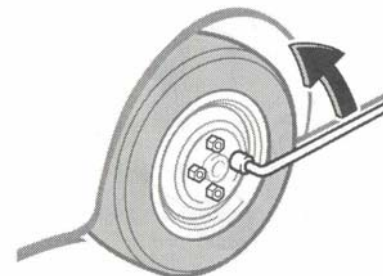

Before jack-up, please unscrew the wheel bolts counterclockwise to loosen them. To strengthen unscrewing, you can nest a spanner into the bolt with its handle on the right, and grip the handle end to pull up (see figure above). Please avoid the spanner slipping out of the bolt.

**Do not remove the bolts, just loosen them.**

### Friendly Tips

- **Do not use motor oil or lubrication oil on the bolts, or the bolts will get loose to make the tire drop off and cause serious accident.**

**4. Place the jack under the proper lifting point, as shown in the figure.**

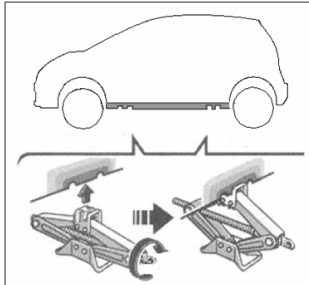

Make sure that the jack is placed on the flat and solid ground.

**5. Height that allows installation of spare tire.**

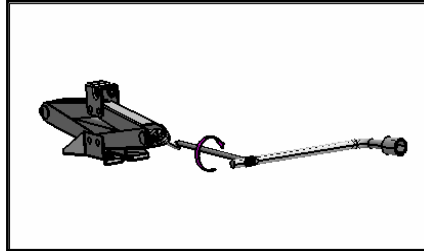

Please notice that it needs larger clearance to install the spare tire than remove the flat tire.

For jack-up, please insert the jack handle into the jack (loose joint) and rotate it clockwise. When the jack touches the car and starts lifting, please check again if the jack is in the right position.

### Friendly Tips

- **When the car is supported completely by jack, no one is allowed to stay under the car.**

**6. Remove the wheel bolts and replace the tire.**

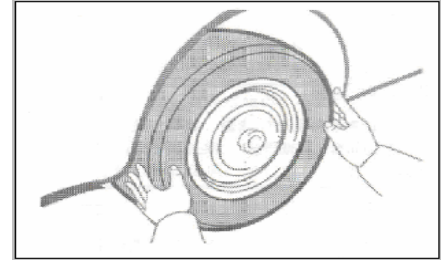

Take off the flat tire and put aside.

Roll the spare tire to the installation position, aim the bolt hole at tire hole, and then screw the tire bolt and fasten it (with a torque of 108 N • m).

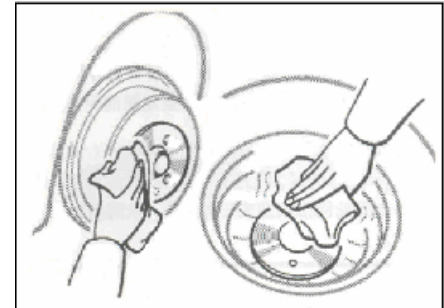

Before installation, please brush off all corrosive materials on the installation surface with a wire brush. During the

installation, the metal areas on the installation surface must be well connected with each other, or the wheel bolts may get loose and the tire may drop off while driving.

**Reinstall all the wheel bolts.**

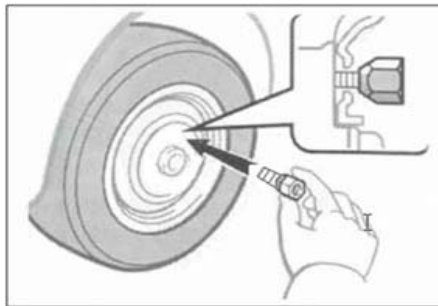

Before reinstallation, please use your hands to screw the wheel bolts firmly.

#### Friendly Tips

- **Do not use motor oil or lubrication oil for the bolts, or the bolts will be tightened overly and damaged. In this case the bolts will get loose to make the tire drop off and cause serious accident. So, if there is motor oil or lubrication oil on the bolts, please clear them off.**

#### 7. Lay down the car thoroughly and screw the wheel bolts firmly.

To lay down the car, please rotate the jack handle counterclockwise.

Please use a spanner to screw the bolts. Do not use any other lever tools except your hands, like hammer, tube, or your feet. Make sure the spanner is nested into the bolts firmly.

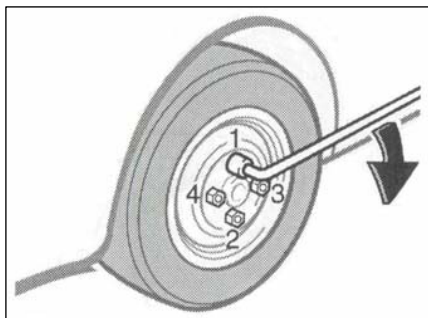

As per the above order, screw the bolts tighter and tighter one by one until all the bolts are fastened firmly.

#### Friendly Tips

- **Please make sure no part of your body and no one nearby will get injured while laying down the car onto the ground.**
- **When the tire is replaced, please use the spanner with a torque of 108N·m (11kgf·m) to screw the bolts. Or the bolts will get loose to make the tire drop off and cause serious accident.**

#### After tire replacement

##### 7. Check the replacement tire pressure.

Adjust the tire pressure to the specified value in Section 8. If the current pressure is lower than specified value, please drive the car slowly to the nearby service station for air charging until the tire pressure reaches specified value.

Do not forget to install the tire valve cap, or dust and moisture will enter the valve core to cause possible air leakage. If you have

lost the tire valve cap, please use a new one immediately.

**8. Collect all the tools, jack, and flat tire properly.**

After tire replacement, please use a torque spanner to screw the wheel bolts to the specified torque in Section 8. The flat tire should be repaired by technician.

**Friendly Tips**

- Before driving, please make sure all the tools, jack, and flat tire are fixed in their storage position so as to reduce the possibility of personal injury caused by crash or emergency braking.

**If the car gets stuck**

If the car gets stuck in snow field, mud field, or sand field, please try to get it out by pushing it forward and backward.

**Friendly Tips**

- While driving, if there are people or objects near the car, please do not try to move the car by pushing it forward and backward. Because in this way, the car will get out and suddenly move forward or backward to cause bodily injury or object damage nearby.

**The car needs towing**

Towing Forward



Towing Backward



Towing by Platform Truck



If you use proper towing gear to tow the car, it will not be damaged.

Improper towing way may damage the car. Most towing personnel know the right towing method, but something may go wrong accidentally. To avoid damage to the car, please follow the precautions below.

### Precautions for Towing

Towing should use safety chain system and obey national, provincial, and local law. The wheel and axle touching the ground should be in good condition. If they are damaged, you will need platform truck for towing.

### Emergency Towing

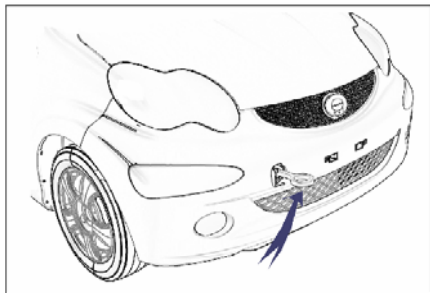

For towing, you can entrust the service store authorized by BYD to handle on your behalf.

If you can not find a tow company for emergency situation, please tie the towing cable or chain to the emergency towing hook at the bottom of the car and conduct a temporary tow carefully.

#### Notice

- ◆ Please use the specified towing hook, or the car may be damaged.
- ◆ Do not tow the car backward with all four wheels on the ground, or it will seriously damage the transmission.

The driver should sit inside driving the car and controlling the brake.

Towing in this way may only move the car slowly for a short distance on the hard road. Meanwhile the wheels, axle, transmission, steering wheel, and brake should be in good condition.

#### Friendly Tips

- While towing, please avoid sudden startup and unstable driving operation, because they will exert great stress on emergency towing hook, and towing cable or chain. The hook, cable, or chain may crack to result in serious personal injury or damage to the car.

#### Notice

- ◆ Please use the towing cable or chain designed specifically for car towing. Tie the cable or chain to the towing hook firmly.

Before towing, please release the parking brake and set the transmission in the neutral position. The key should be at "I" (idle engine) or "II" (running engine).

#### Friendly Tips

- If the engine can not run, the power-assisted device of brake and redirector will not work. So direction changing and braking will be more difficult than usual.



## **Section 5**

### Chapter 5 Anti-corrosion and Automobile Exterior Maintenance

Anti-corrosion .....	95
Washing and waxing .....	96
Inside cleaning .....	97

## Anti-corrosion

Proper maintenance for the car can prevent corrosion for a long time.

### The common causes for car corrosion:

- Saline-alkali, dust, and moisture concentrate at the unaccessible parts of bottom of the car.
- The paint film or bottom layer is scratched by slight crash or foreign bodies such as sand.

### If you live in a special area or operate the car in special circumstance, please be careful:

- The dust on the road with saline-alkali or chemical substances will speed up corrosion. The air along the seacoast or in contaminated industrial park is also saline.
- High moisture will speed up corrosion, especially in the area with a temperature just over 0° C.
- Certain parts of the car are always under moisture or humidity. Even if the rest parts are kept dry, corrosion will occur.
- High compartment temperature may cause corrosion to the parts which can not get dry quickly due to lack of proper ventilation.

The above items show the importance of

keeping the car, especially the bottom part clean, and repairing the damaged paint film and protection film ASAP.

### To avoid corrosion for BYD F0, please follow the instructions below:

#### Wash the car regularly.

Washing your car regularly can keep it clean. But for anti-corrosion, please abide by the following points:

- In winter if you drive the car on the road with saline-alkali or live by the sea, please wash the running part of the car at least once per month to reduce corrosion.
- High pressure or steam is effective for cleaning chassis and wheel cover. Slurry and dirt in these positions are difficult to remove, you need to pay extra attention as getting the slurry and crumbs wet without removing them may cause severer damage. Please avoid the dust jamming the drain hole on the lower edge of the door, sill plate, and frame, or water accumulated will lead to corrosion.
- Arrange a thorough cleaning for the chassis when winter is over.

**For more hints, please see "Washing and Waxing".**

**Check the car's paint and decorative pieces.** When there is any fragment or crack on the paint film, please repair it at once to avoid the access to corrosion. If the fragments or cracks peel off the metal surface, please contact the service store authorized by BYD for repair.

**Check inside of carriage.** Moisture and dust will concentrate beneath the floor mats and cause corrosion, please check the underside of the floor mats frequently and make sure it is dry. When you transport chemicals, detergent, fertilizer, or salt, please pay particular attention and use proper containers for transportation. In case of any spillage or leakage, please clean it immediately and keep dry.

**Use mudguard.** When driving in saline-alkali area or on the gravel road, you can use mudguard to protect the car. The mudguard with big size and short distance from the ground has better effect. Small mudguard for wheel cover of BYD F0 is a decorative item. The service store authorized by BYD can provide the service of mudguard installation to the users.

**Park the car in well ventilated garage or other place with roof, but not in damp or unventilated garage.** To wash your car in the garage or drive on the wet or snowy road will get the garage damp and thus cause corrosion. Even though the garage is dry, the car will also get damp and suffer corrosion if it is poorly ventilated.

## Washing and waxing

### Cleaning for BYD F0

Clean the car in normal way.

In the cases below, the paint film may peel off and there will be corrosion in the car body and parts. Please clean the car immediately.

- Driving along the seacoast.
- Driving on the road covered with anti-freezer.
- Stuck with coal tar, resin, bird manure, and dead insects.
- Driving in the area with heavy smoke, coal ash, dust, iron fillings, or chemical substances.
- The car is obviously covered with dust and slurry.

### Manual Cleaning for BYD F0

Clean the car in shade place when it does not feel hot.

#### Friendly Tips

- **Please protect your hands from hurt while cleaning the underside of the floor or chassis.**

1. Use water pipe to wash away the loose dirt and all the slurry and saline-alkali at the bottom of the car and in the sunken places of the wheels.
2. Use neutral detergent to wash the car. The detergent mixture should meet the requirements from its manufacturer. Dip a soft cloth into the detergent to wipe the car, and use soap water and clean water to remove the dirt.
3. Thorough wash: When the soap water get dry, it will leave taints. So in the summer, please use clean water to flush each part of the car after washing.
4. To avoid leaving water mark, please dry the car body with clean soft towel. Do not wipe or press too hard, or the paint surface may be damaged.

**Decorative plastic pieces on wheels:** The decorative plastic pieces are easy to be damaged by organic substances. If any organic substance spills onto the decorative pieces, please wash it away by clean water and check whether the decorative pieces are hurt.

#### Friendly Tips

- **Do not install the seriously damaged decorative pieces for plastic wheels, or they may drop off the wheel while driving and thus lead to accident.**

**Aluminum wheel:** wash it only with neutral soap water or neutral detergent.

**Plastic bumper:** be careful to wash it. Do not use detergent with grinding materials to wipe it, because its front side is soft.

**Asphalt from the road:** wash it by turpentine or detergent marked as non-harmful to the painted surface.

Notice
--------

<p>◆ <b>Do not use such organic substances as gas, kerosene, naphtha, and strong solvent, or you may get toxic or the car will be damaged.</b></p>
--

### Auto Car Washing

You can wash your car at auto carwash station. But please take notice that some types of brushes, unfiltered water, and the wash process adopted by the machine will hurt the painted surface. Hurt to the painted surface will reduce its duration and gloss particularly for the car in dark color. Usually the staff from carwash will tell you which washing process is most proper for the painted surface.

### Waxing for BYD F0

To keep the glossy as brand-new, we suggest you to polish and wax the car once per month; if the car body is not quite water-resistant, please do waxing.

1. Before waxing, please wash the car and dry the body even if you use the mixture of detergent and wax.

2. Please use quality polish and car wax. When the polishing on the car body has been weathered seriously, please use the cleaning polish separated from the car wax. Follow the instructions and precautions from the manufacturer. The chrome plated surface also need polishing and waxing.
3. On a large surface, if the water can not form beads but stay on the surface, you shall wax the car.

Notice
--------

<p>◆ <b>When the car is placed in painting &amp; polishing workshop with high temperature for repainting, please remove the plastic bumper from the car, or high heat may damage the bumper.</b></p>
--

### Inside cleaning

Friendly Tips
---------------

- |  |
|--|
| <ul style="list-style-type: none"> <li>● <b>Do not wash the floor with water or allow the water to flow onto the floor while cleaning the car inside or outside, as the water may enter the audio devices or other electric appliances on the carpet (mat), which may result in malfunction of the devices and corrosion of the car body.</b></li> </ul> |
|--|

### Carpet

Please use quality foam detergent to clean the carpet.

First use the dust collector to absorb the dust. Several kinds of foam detergents are applicable, some are packed in aerosol can, and the rest are powder or liquid to be mixed with water for foam. Use a sponge or brush dipped with foam to wash the carpet, and the sponge or brush shall move in circle.

No clean water is needed, just keep the carpet dry.

Please read the instructions for detergent and strictly follow them.

### Seat Belt

The seat belt can be washed with neutral soap water or tepid water.

Use sponge or soft cloth to clean it. And check if the seat belt has evidence of abrasion or cut.

#### Notice

- ◆ The seat belt can not be cleaned with coloring agent or bleach, or its strength will be weakened.
- ◆ Do not use the seat belt until it is dry.

### Doors and Windows

Doors and windows can be cleaned with normal household detergent.

#### Notice

- ◆ While cleaning the inside of the back window, please be careful not to scratch or damage the heater strip or the plug.

Please use damp and soft cloth to clean the air conditioning control panel, car stereo system, instrument panel, central control panel, and switches.

Dip a clean and soft cloth into the water or tepid water, and then wipe away the dust gently.

#### Notice

- ◆ Do not use organic substances (like solvent, kerosene, alcohol, or gas) and acid-base solutions, because these chemicals will lead to color change, taint, and peeling on the surface.
- ◆ Before using detergent or polish, first please make sure they do not include the above substances.
- ◆ If you use new liquid detergent, please do not spill the liquid onto the inside surface of the car as they may contain above substance. You should clean up the spilled liquid at once in the way described previously.

### Leather Ornament Inside the Car

For leather ornaments, you can use neutral detergent designed for woolen fabrics to clean them.

Use a soft cloth dipped with 5% of neutral detergent designed for woolen fabrics to erase the dust, and then wipe off the residual detergent with a clean wet cloth.

If any part of the leather gets wet after cleaning, please wipe it dry with a clean soft cloth and keep it in the ventilated shade for drying.

#### Notice

- ◆ If you can not wash off the dirt with neutral detergent, please use the detergent without organic solvent.
- ◆ Do not use organic substances to clean the leather, like naphtha, alcohol, gas, or acid-base solution, because they will make the leather fade.
- ◆ Dirty leather ornaments will generate mold. Please try to avoid oil stain and always keep the ornaments clean.

◆ Long-time exposure to the sun may cause solidification or shrinkage to the leather surface. So please park your car in the shade especially in summer.

◆ In the hot summer, the temperature inside the car tends to rise. Do not place those articles made of vinyl plastic, plastic, or waxy materials on the leather ornaments, because those articles will stick to the leather in high-temperature environment.

◆ Improper cleaning for the leather ornaments may lead to color fading or spots.

In case of any query for cleaning the car, please consult the local service store authorized by BYD.

**Section 6**

## Chapter 6 Maintenance Knowledge

Maintenance.....	101
Signs for repair arrangement.....	101
Maintenance schedule for BYD F0.....	101

## Maintenance

### Regular maintenance is very important.

Here BYD recommend you to maintain F0 according to the maintenance schedule below. Regular maintenance is helpful in:

- Fuel saving
- Extension of service life
- Joy of driving
- Safe driving
- Stable driving
- Warranty compliance
- Compliance with government rules

### Signs for repair arrangement

Please pay attention to the auto performance, sound change, and the apparent signs for repair arrangement. Below are some significant signs:

- The engine is misfiring, unstable, or with a bang.
- Power is decreasing dramatically.
- The engine is with strange noise.
- There is water leakage from the underneath of the car. (Water drops for working air conditioning are normal.)
- The exhaust noise is changing. (Perhaps there is carbon monoxide leakage. You need to open the window while driving and examine the exhaust

system right away.)

- The tire is leaking air. There is excessive tire noise while turning, and uneven tire abrasion.
- The car will deflect to one side while running on the flat ground in a straight line.
- There is strange noise related to movement of the suspension system.
- Braking effect is dropping. The brake pedal or clutch pedal feels like a sponge, or almost touches the floor. While braking, the car deflect to one side.
- The engine coolant temperature keeps on the high side.

In case of above conditions, please take your car to the service store authorized by BYD for examination and repair at once.

Friendly Tips
<ul style="list-style-type: none"> <li>● <b>Do not continue to drive the car before examination, or there may be serious damage to the car or personal injury.</b></li> </ul>



## Maintenance schedule for BYD F0

- Maintenance schedule for BYD F0 is to ensure stable driving, void malfunction, safe and economical driving.
- Please refer to the maintenance schedule for maintenance interval. It is subject to the readings on the milometer or time interval, whichever comes earlier.
- Please also maintain the items already out of its final time at the same time interval.

Maintenance interval for each item is recorded in the maintenance schedule.

**For rubber hose (used for cooling and heating system, braking system, and fuel system), please contact the service store authorized by BYD to arrange an examination according to the maintenance schedule for BYD F0.**

They are very important maintenance items. In case of any degradation or damage to the hose, please replace it with a new one immediately. Please note the rubber hose will degrade over time and thus come into inflation, abrasion, and burst.



**Maintenance schedule**

**Maintenance Operations:** I=to examine, repair, or replace if necessary; R=to replace, change, or lubricate; C=to clean.

Maintenance Interval  Maintenance Items	Milometer Readings or Months, Whichever Comes Earlier															
	× 1, 000(km)	3	8	13	18	23	28	33	38	43	48	53	58	63	68	73
	Months	First Time	6	9	12	15	18	21	24	27	30	33	36	39	42	45
<b>Engine &amp; Transmission</b>																
1 Check if the ribbed belt is with crack, flying chip, or abrasion and adjust its intensity.		I		I		I		I		R		I		I		I
2 Check if the ignition cable is damaged.		I		I		I		I		I		I		I		I
3 Check and replace the spark plug.	General Service Condition	Replacement for Each 10,000km														
	Severe service Condition	Replacement in Advance as Required														
4 Check the crankcase ventilation system (PCV valve and air hose)		I		I		I		I		I		I		I		I
5 Check if the water-cooling pipe is damaged and whether its connection is firm.		I		I		I		I		I		I		I		I
6 Check the engine coolant level in the tank.		I		I		I		I		I		I		I		I
7 Replace the engine coolant.		Replacement for Each 2 Years or 40,000km														
8 Replace the core of the air cleaner.	General Service Condition	Cleaning for Each 2,500km; Replacement for Each 15,000km														
	Severe service Condition	Replacement in Advance as Required														
9 Change the motor oil.		R: Replacement for Each 5,000km or 6 Months														

	Severe service Condition	R: for Each 3,000km													
10 Replace the oil filter.	General Service Condition	R: Replacement for Each 5,000km or 6 Months													
	Severe service Condition	R: for Each 3,000km													
11 Check the battery accumulator.		I		I		I		I		I		I		I	
12 Check the idle speed of the engine.		I		I		I		I		I		I		I	
13 Check the ignition timing.		I				I				I				I	
14 Check and adjust the valve clearance.		I		I		I		I		I		I		I	
15 Check if the exhaust fitting is leaking air.		I		I		I		I		I		I		I	
16 Check the control cable of the throttle valve.		I		I		I		I		I		I		I	
17 The throttle body.		Cleaning for Each 10,000km													
18 The oil nozzle.		I				I				I				I	
19 Check the oxygen sensor.		I		I		I		I		I		I		I	
20 Check the three-way catalytic converter.		I		I		I		I		I		I		I	
21 The fuel filter.		Replacement for Each 10,000km or 6 Months													
22 The fuel tank cover, fuel pipe, and terminal.		I				I				I				I	
23 The active carbon canister.		I		I		I		I		I		I		I	
24 Check and change the gear oil inside the manual transmission.	General Service Condition	I	R			R		I		R		I		R	
	Severe service Condition	R: Time Period Reduction as Required													
<b>Chassis &amp; Car Body</b>															
25 Check the fixation screw fastening the chassis.		I		I		I		I		I		I		I	
26 The brake pedal and parking brake.		I		I		I		I		I		I		I	
27 The brake pad and brake disc.		I		I		I		I		I		I		I	
28 Brake fluid.		I	I	I	I	I	I	I	I	R	I	I	I	I	I

29 The brake pipe and hose.	I		I		I		I		I		I		I		I
30 Power-assisted steering fluid.	I	I	I	I	I	I	I	I	R	I	I	I	I	I	I
31 The steering wheel and draw bar.	I		I		I		I		I		I		I		I
32 The dust helmet of transmission shaft.	I		I		I		I		I		I		I		I
33 The ball pin and dust helmet.	I		I		I		I		I		I		I		I
34 The front and back suspension system.	I		I		I		I		I		I		I		I
35 The tire and inflation pressure.	I	I	I	I	I	I	I	I	I	I	I	I	I	I	I
36 Check the front and back wheel alignment.	I		I		I		I		I		I		I		I
37 Check if the wheel bearing is with clearance.	I		I		I		I		I		I		I		I
38 Check the function of the clutch system and adjust the pedal travel.	I		I		I		I		I		I		I		I
39 Cooling or heating system.	I		I		I		I		I		I		I		I
40 The filter of air conditioning.	I		R		R		R		R		R		R		R
41 The refrigerant of air conditioning.	I		I		I		I		I		I		I		I
42 Check the air bag system.	I		I		I		I		I		I		I		I
43 Check damage to the car body.	Annually														

Notes:

- (1) Time period for replacement of oil filter can be reduced based on the dirt level of the petrol engine.
- (2) Severe service condition means:
  - Always running in the dusty area or exposure to salty air.
  - Always running on the bumpy, water-logging, or mountain road.
  - Running in cold areas.
  - The engine frequently suffers long-lasting idle running or short-distance running in the cold season.
  - Frequently use of the brake, frequent hard braking.
  - It often functions as a tow trailer.
  - It is used as a taxi.
  - Running time in urban area with busy traffic and a temperature over 32°C exceeds 50% of the total running time.
  - Running time at the speed of 120km/h with a temperature over 32°C exceeds 50% of the total running time.
  - Always running overload.

## **Section 7-1**

### Chapter 7 Self-Maintenance

#### **1. Preface**

Appearance of the engine compartment.....	107
Fuse layout.....	108
Precautions for self-maintenance.....	109
Positioning of the Jack.....	110

## Appearance of the engine compartment

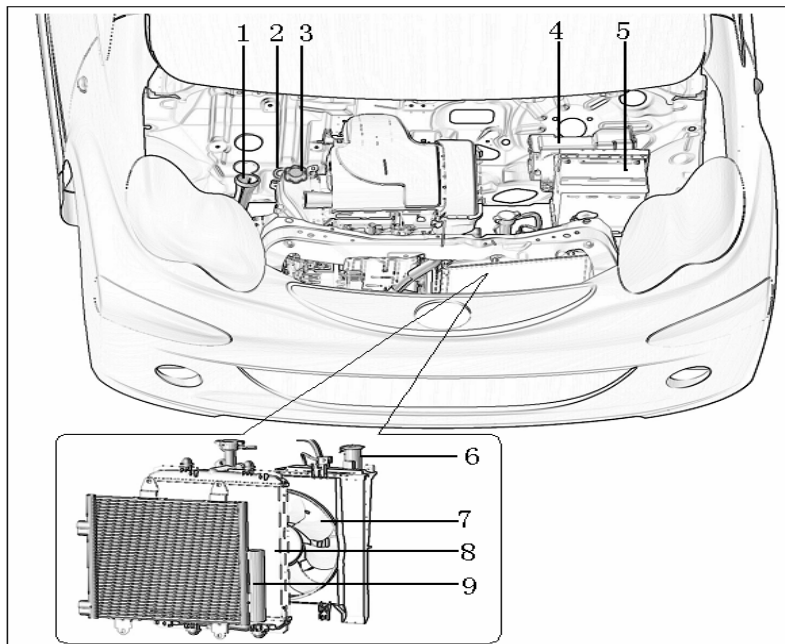

1. Detergent tank for the Wiper Front and Back
2. Oil Dipstick
3. Oil Filler Cap
4. Distribution Box of Engine Compartment
5. Battery
6. Inflated Tank
7. Cooling Fan
8. Radiator
9. Condenser

## Fuse layout

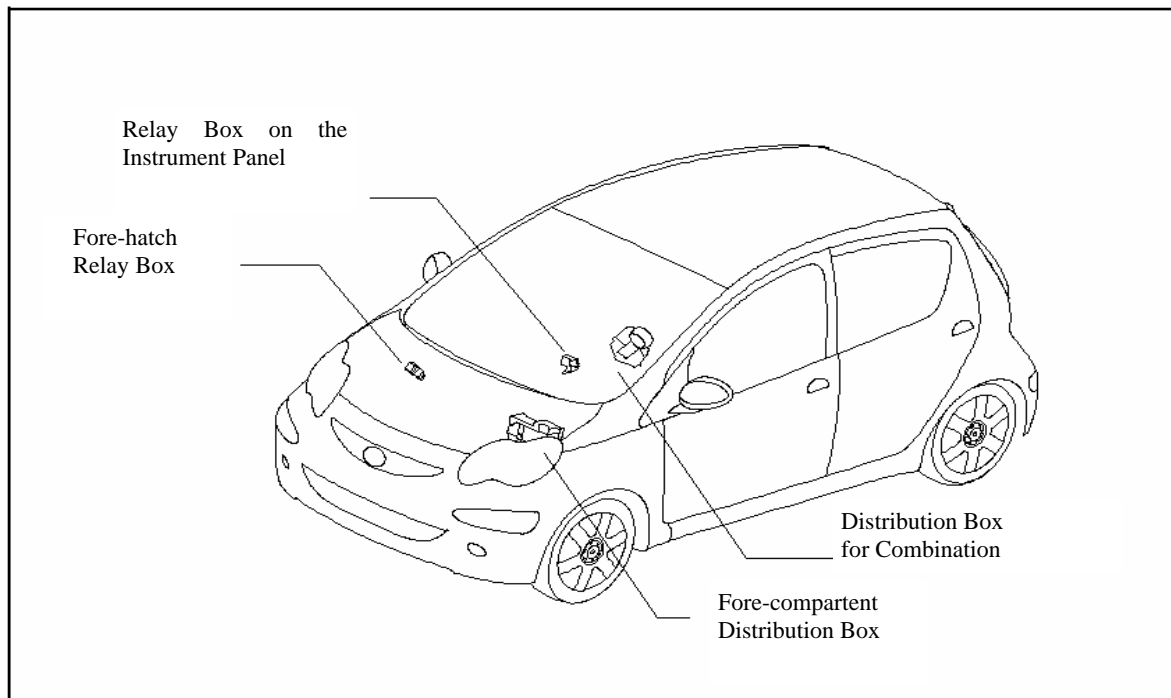

For the name of electric parts protected by each fuse, please see “Fuse & Relay” in Section 8.

## Precautions for self-maintenance

For self-maintenance, please follow the correct procedures here.

Please be careful that improper or incomplete maintenance may cause handling problems.

This section is intended for easy self-maintenance operation only, but as described in Section 6, some parts herein must be maintained by qualified technician with special tools.

For maintenance operation, please follow the precautions below so as to avoid accidental injury.

For examination and replacement, please contact the service store authorized by BYD.

### Friendly Tips

- When the engine is running, please keep your hands, cloths, and the tools away from the cooling fan and driving belt (take off your exposed necklace, watch, and necktie).
- After startup, the temperature of the engine, radiator, exhaust device, hose of the spark plug, motor oil, coolant, and spark plug will get very

high. Please be careful and do not touch them.

- When the engine is with high temperature, please do not remove the radiator cap or loosen the drain plug, or you may get a burn.
- Do not put any flammable objects in the engine area, like tissue or crumbs.
- Do not smoke, or the spark may cause fire of fuel or battery.
- For disposal of the battery, please be careful since it contains toxic gas and erosive sulphur acid.
- Do not get under the bottom of car when it is being lifted up, usually by auto hydraulic devices.
- When you work nearby the cooling fan or radiator, make sure the ignition switch is turned off. If it is turned on, the high-temperature coolant or working air conditioning will make the cooling fan running.
- If you are working under the environment with possibility of

exposure to flying and dropping objects or spray, please use appropriate eye protection.

- Please avoid to touch the motor oil repeatedly, because it contains potential toxic substances and may cause skin irritation, skin inflammation, or even skin cancer. When you smear the motor oil by accident, please wash it with soapy water.
- Keep the used motor oil in a safe container, but not in household waste bin, sewer, or anywhere the children can reach. You can call the dealer or service store authorized by BYD to ask for more information about recycling and disposal of motor oil.
- Please be careful in adding the brake fluid, because it is harmful to your hands and eyes. When the brake fluid sticks to your hands or goes into your eyes by accident, please wash the affected parts with water immediately. If you still feel uncomfortable, please go and see the doctor soon.



## Attention

- ◆ There is strong current in the battery and high voltage in the ignition coil, never make a short circuit.
- ◆ The engine coolant in the radiator shall be quality ethylene glycol organic compounds free of silicate, amines, nitrite, or borates. This coolant contains 50% cooling fluid and 50% deionized water.
- ◆ If you spill the coolant by accident, please clean it up with water so as to avoid erosion to the parts and the painted surface.
- ◆ Do not allow any dirt to enter the hole of the spark plug.
- ◆ The outer electrode of the spark plug should not be fixed opposite to the central electrode.
- ◆ Please use the specified spark plug. Other spark plugs may cause damage, performance fall-off, or noise to the engine,
- ◆ When you spill the brake fluid by accident, please clean it up with clear

water so as to avoid damage to the parts and the painting.

- ◆ You should install the air cleaner, or the engine may be damaged by excessive abrasion.
- ◆ Please do not use paper handkerchief to wipe the glass surface.
- ◆ When you close the engine compartment cover, please check if there are tools or crumbs left.

## Positioning of the Jack

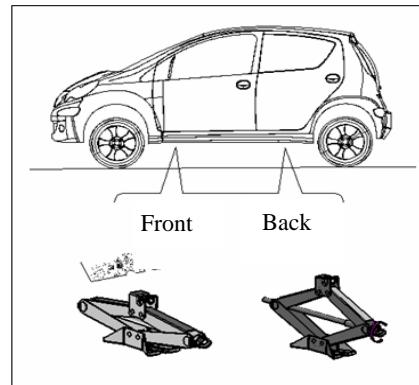

In order to lift the car by jack, please put the jack in the right position as showed on this figure.

**Friendly Tips**

To reduce the possibility of personal injury, please obey the instructions below when you try to lift the car by jack.

◆ Try to avoid breathing in the exhaust gas from the engine, because the exhaust gas contains carbon monoxide, which is colorless and smellless. It will cause serious injury.

◆ No part of your body is allowed to stay under the car lifted by jack, or there may be bodily injury.

◆ When the car is lifted by jack, please do not start or operate the engine.

◆ Park your car on the firm and flat ground and make sure the parking brake is pulled up. If necessary, please block the tire opposite to the lifting point.

◆ Make sure the jack is placed on the right lifting point. To lift the car by a jack not placed properly may damage the car or make the car drop down from the jack and thus cause

injuries.

◆ When the car is supported completely by jack, no one is allowed to stay under the car. Please use car support stand to hold it.

◆ When someone is in the car, please do not lift it.

◆ Do not put any materials on the top or bottom of the jack while lifting.

**Notice**

◆ Make sure the jack is stored properly, or it may damage the car.

## **Chapter 7-2**

### **Self-maintenance**

#### **2. Engine and Chassis**

Check the oil level.....	113
Check the engine coolant level .....	114
Check the radiator and condenser .....	115
Check the tire pressure .....	115
Check and replace the tire .....	116
Rotate the tire .....	117
Replace wheel .....	118
Notes on aluminum wheels .....	119

## Check the oil level

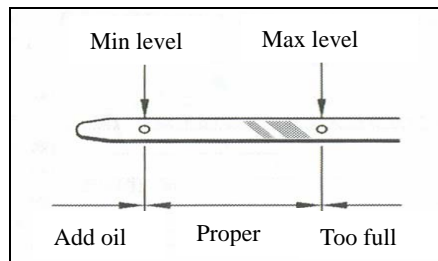

**When the engine is in the working temperature, shut down the engine and check the oil level by the oil level dipstick.**

- To obtain the accurate reading, you should park the car on flat ground. Wait a few minutes after shutting down the engine to let the oil concentrate at the bottom of the engine.
- Pull out the oil level dipstick, place a piece of cloth on its end and wipe it clean.
- Reinsert the oil level dipstick — try to insert it as deeply as possible, otherwise the reading will be

inaccurate.

- Pull out the oil level dipstick, place a piece of cloth on its end and check the oil level.

### Notice

- ◆ Please pay attention to not drip the oil onto the parts of the car.

**If the oil level is lower or slightly higher than the Min oil level line, you should add oil of the same type into the engine.**

Remove the oil cover, add a small amount of oil and check the oil level dipstick. Repeat this process until the oil level is close to the Max oil level line. We suggest you to use funnel to add the oil.

After adding oil, the oil level shall be between Min level line and Max level line on the oil level dipstick.

When the oil level reaches the proper range, please install the oil cover and screw it tight.

### Notice

- ◆ Please pay attention to not drip the oil onto the parts of the car.
- ◆ Avoid adding too much oil, otherwise the engine will be damaged.
- ◆ When you finish adding the oil, please check again the oil level on the oil level dipstick.

### The choice of oil

Please use the lubricants approved by the service store authorized by BYD or the same goods meeting the following grade and viscosity.

Oil grade of gasoline engine:

SAE 5W—30	Above -30℃
SAE 10W-30/40	Above -15℃
API grade	SG grade or above

Amount: 3 L

The specification of gear oil used by the transmission:

75W—90		above -30°C
80W—90		above -15°C
80W—90	or	The whole year in the South
80W—140		
API grade		GL-4 grade or above

Amount: 1.6-1.7L

### Recommended oil viscosity (SAE):

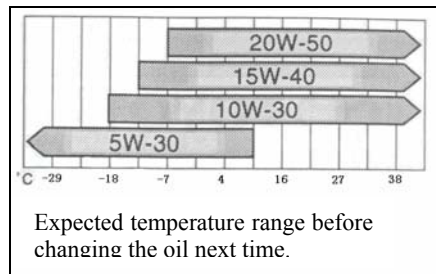

**In the extremely cold days, if you use SAE 10W-30 or oil with higher viscosity, the engine will be hard to start, so oil SAE 5W-30 is recommended.**

### Oil identification mark

Some oil container has one or two API register labels for reference when choosing oil.

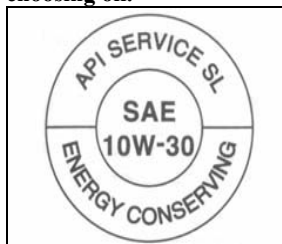

### API classification mark

API classification mark is located somewhere outside the oil container.

The upper part of the label is the oil quality specified by API (American Petroleum Institute), such as SL. The middle part of the label is SAE viscosity grade, such as SAE 10W-30. “Energy-Conserving” on the lower part of the label means this oil is fuel-saving.



### ILSAC certification mark

The certification mark of ILSAC (International Lubricant Standardisation and Approval Committee) is on the front side of the container.

### Check the engine coolant level

**In the engine cooling state, check the transparent coolant tank. The coolant level in the tank is proper if it is between “FULL” and “LOW” line. If the level is low, you need to add coolant. (About the type of coolant, refer to the following “Coolant Type Choice” .)**

The coolant level in the tank will vary with the engine temperature. However, if the liquid level is at the “LOW” line or below, you need to add the coolant to make the liquid level up to the “FULL” line.

After adding coolant, if the coolant level drops in a short time, the system may have leakage. You should look and check the radiator, hose, radiator cover, vent cock as well as pump.

If you can not find out any leakage, you can go to the service store authorized by BYD to test the cover pressure and check whether the cooling system have leakage or not.

### Friendly Tip

- **To avoid burns, please don't remove the radiator cover when the engine temperature is high.**

### Coolant type choice

Only the coolants approved by the service store authorized by BYD can be used, you should choose the suitable type of coolant according to the ambient temperature. Inappropriate use of the coolant will damage the engine cooling system.

### Notice

- ◆ **Please don't use water as coolant.**

You can contact the service store authorized by BYD for details.

### Check the radiator and condenser

When radiator or condenser is too dirty or you are not sure about the extent of dirt, please send the car to the service store authorized by BYD.

### Friendly Tip

- **When the engine is hot, please pay attention not to touch the radiator or condenser to avoid scalding.**

### Notice

- ◆ **Don't check it by yourself to avoid damage to the radiator and condenser.**

### Check the tire pressure

Keep the tire with proper pressure. You can refer to Chapter 8 for the recommended cold tire pressure and the tire size.

You should check the tire pressure once two weeks or at least once a month. Don't forget to check the spare tire pressure.

Improper tire pressure may cause higher fuel consumption and reduce the driving comfort, the tire life and the traffic safety.

If the tire needs to be charged regularly, you shall have it checked by the service store authorized by BYD.

### Friendly Tip

**Keep the tire pressure proper. Otherwise, the following will happen and cause accidents.**

#### Low tire pressure(underinflated)

- **Excessive abrasion**
- **Abnormal abrasion**
- **Difficulty in handling the car**
- **The tire is too hot to cause air leakage.**

- The performance of the tire hermetic seal will be weak.

- Wheel deformation and/ or tire separation.

#### High pressure(overinflated)

- Difficulty in handling the car
- The central wheel pattern is excessively abraded.
- The possibility that the hard road causes damage to the tire is bigger.

When checking tire pressure, you should comply with the following instruction:

- You can check the tire pressure only when the tire is cold. You can get the proper cold tire pressure reading only if the car has been in parking for at least 3 hours or has been driven no more than 1.5km(km).
- You need to use the tire pressure gauge. Estimate the tire pressure by experience may have errors. In addition, difference of only a few pounds in tire pressure will reduce the performance of taking and driving a car.

- Please don't deflate the tire or reduce the tire pressure after driving. It is normal that the tire pressure get higher after driving.

- Make sure that the tire valve cover is installed. If there is no valve cover, dust or moisture will enter the valve core and lead to leakage. If the valve cover is lost, you should install a new one immediately.

### Check and replace the tire

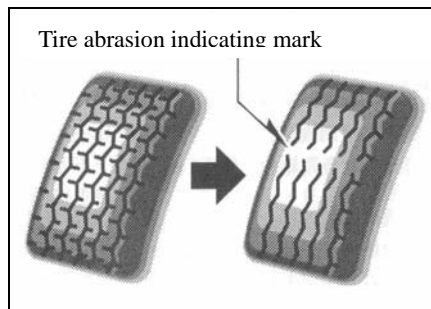

#### Check the tire

Use the tire abrasion indicating mark to check the tire surface. If you can see the indicating mark, you should replace the tire. The tire of F0 embeds abrasion indicating

mark to indicate when you should replace the tire. If the depth of the tire is abraded to 1.6mm or less, you can see the abrasion indicating mark. If you see the abrasion indicating mark appearing in two or more adjacent pattern grooves, you need to replace the tire. The danger of skidding is greater if the tire is thinner.

If the depth of the tire is abraded to 4mm(mm) or less, the snow tire function will be lost.

**If you find the tire damages such as cut, crack, deep crack with the cord fabric exposed or expansion, that means the tire has an internal damage, you need to replace it.**

If the tire leaks frequently or it can't be repaired because of the size and location of cuts and other damages, you need to replace the tire. If you are not sure, please contact the service store authorized by BYD.

If the leak happens in driving, don't continue driving. Even moving a short distance may cause unrepairable damage to the tire.

**Any tire that has been used more than six years, even if there is no distinct damage, should be checked by qualified technical staff.**

Even if the tire has never or infrequently been used, its performance will degrade because of aging.

This also apply to the spare tire and tires in inventory.

### Replace tire

**When replacing tire, you should use a tire which has the same size, structure and the same or greater carrying capacity than the tire to be replaced.**

Using the tire of any other size or type will seriously affect the driving, taking, the calibration of speedometer/odometer, distance from ground and the distance between car and tire or the tire chain.

### Friendly Tips

**Please comply with the following instruction, otherwise, it may cause serious accidents.**

- **Don't use radial tire, bias belted tire or diagonal-ply tyre to the car, otherwise it may cause typical operation danger and make the car out of control.**
- **Don't use the other tire size other than the manufacturer's recommendation, otherwise it may cause a typical operation danger and make the car out of control.**

**Never use old tires on the F0.**

It is dangerous to use the tire of unknown source.

**We recommend that you replace the four tires at the same time, or at least the two front or rear tires at the same time.**

Please refer to Chapter 4 "If the tire deflates" for the steps of tire replacement.

You should keep the wheels' balance after replacing the tire.

Unbalanced wheels will affect vehicle operation and the tire life. In normal use, the wheels will lose its balance gradually, so you should check them aperiodically to keep the wheels balance.

### Rotate the tire

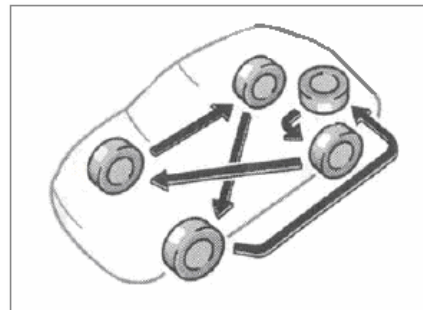

**In order to keep the abrasion of tires at the same level and to extend the tire life, we recommend that you rotate the tire when you travel every 10, 000 kms. However, the most appropriate time to rotate the tire is in accordance with the driving habit of the driver and the road condition.**



When rotating the tire, you should check whether there is uneven abrasion or damage. Improper tire pressure, improper wheel alignment, unbalanced wheel or frequent braking may cause abnormal abrasion of the tire.

### Choice of tire chain

Use the tire chain of proper size.

The using rule of tire chain varies according to the location or the type of the road. So, you should make sure the local rule before you install the tire chain. The installation of tire chain

Install the tire chain on the front tires as tightly as possible. Don't use the tire chain on the rear tires. After driving 0.5—1.0 km, please tighten the tire chain once again.

You should comply with the instruction of tire chain factory when installing the tire chain to the tires.

If you used a wheel cover, it will be scratched by the tire chain. So you must remove the wheel cover before installing the tire chain.

### Friendly Tips

- The driving speed should not exceed 50km/h or the lower speed limit prescribed by the tire chain factory.
- Drive carefully and pay attention to the bulge objects, holes and a sharp turn, which may result in the vehicle jumping.
- When using the tire chain, please avoid a sharp turn or a locked wheel braking, which could adversely affect the operation of the car.
- When driving the car with tire chain, you should be careful. Reduce speed before making a turn to avoid losing control of the car, otherwise it may result in an accident.

### Replace wheel

#### When to replace wheels

When the wheel has damages such as bending, cracks or severe corrosions, it must be replaced.

If you don't replace the damaged wheels,

the tires may get off from the wheel and the vehicle may be out of control.

#### The choice of wheels

**When replacing the wheel, you should make sure that the replaced wheel has the same capacity, diameter, rim width and bias volume as the old wheel.**

The service store authorized by BYD can replace the wheel properly.

Wheels of different sizes or types may have an adverse effect on the operation, the life of the wheel and bearing, the calibration of speedometer / odometer, brake performance, headlight collimation, bumper height, vehicle height off ground and the distance between tire or tire chain and the body or chassis of the car.

Don't use an old wheel to replace a damaged wheel. Because these wheels may have been disposed or have travelled a lot of mileages, they may cause malfunction without warning. And also the bended wheel that has been repaired has a structural damage, so it can't be used. Don't use the inner tire specially designed for the tire without inner tire on the leaked wheels.

**Friendly Tips**

- **Don't use the wheels with a size other than the factory's recommendation, because it may cause a typical operation danger and make the car out of control, otherwise, it may cause serious accidents.**

- When using the wheel tire chain to adjust the wheel balance, you should only use BYD balance block and plastic hammer or rubber hammer.
- As with all the cars, F0 should be checked for wheel damage regularly. If you find a damage, you should replace it immediately.

**Notes on aluminum wheels**

- The vehicles installed with aluminum wheels should be checked to find out whether the wheel bolts have loosed after the initial 1,600 km travel.
- If you rotate, repair or replace the wheel, you should checked whether the wheel bolts have loosed after 1,600 km travel.
- When using the tire chain, please pay attention to not damaging the aluminum wheels.
- Only the BYD wheel bolts and wrenches specially designed for the aluminum wheels can be used.

## **Chapter 7-3**

### Self-maintenance

#### **3. Electrical appliance parts**

Check the battery status .....	121
Check and replace fuse .....	123
Add cleanser.....	124
Replace bulb.....	125

## Check the battery status

## Notices

## Friendly Tips

## Notices of battery.

Batteries can produce flammable and explosive hydrogen gas.

- When using tools, avoid sparks on battery.
- Don't smoke or use matches near the battery.

Electrolyte contains toxic and corrosive sulfuric acid.

- Keep the electrolyte away from the eyes, skin or clothing.
- Don't drink the electrolyte by mistake.
- You need to wear safety goggles when you work near the battery.
- Keep children away from the batteries.

## Emergency measures

If the electrolyte splashes into eyes, wash them with water immediately, then go to hospital soon. If possible, on the way to hospital, continue to use sponge or cloth dipped with clean water to wash the affected part.

- If the electrolyte splashes on the skin, the skin should be fully cleaned. If you feel pain or burning, you should go to hospital immediately.
- If the electrolyte splashes on the clothing, it may seep in and contact the skin. So you should take off the clothes immediately, if necessary, you should deal according to the foregoing methods.
- If you drink the electrolyte by accident, you should drink plenty of water or milk and eat milk with magnesia, raw eggs or vegetable oil then go to hospital immediately.

## Check the battery exterior

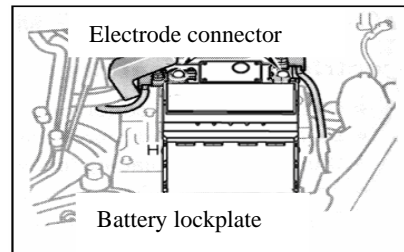

Check whether the battery is corroded or the joint is loose or cracked or the press tool is loose.

- If the battery has been corroded, you should use the liquor mixed of warm water and soda to wash it. Smear grease to the external joint to avoid further corrosion.
- If the joint connector is loose, you should tighten the nut of the clight—but not too tightly.
- Tighten the lockplate until it can keep the battery fixed in place. Excessive tightening will damage the battery box.

### Notice

- ◆ **Before maintenance, make sure the engine and all ancillary equipments are closed.**
- ◆ **When checking the battery, you should disconnect the ground cable on the negative joint ( “\_” mark) first and install it in the last place.**
- ◆ **Avoid causing a short circuit when using tools.**
- ◆ **When cleaning the battery, do not let liquid enter into the battery.**

### Check by the indicator

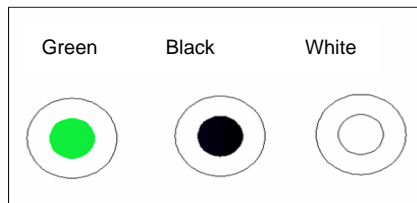

You can know the interior state of the battery according to the description outside the battery and the battery status indicator, as shown in the figure above.

Indicator color	Battery status
Green	Good
Black	Need to charge
White	Need to replace

### Notices on recharging battery

When charging the battery, it will produce hydrogen. Therefore, before charging:

1. Please rotate the ignition key to "0" position and disconnect the battery cathode when charging the battery installed on the car.
2. Before connecting or disconnecting the wire between the charging device and the battery, please power off the charging device.

### Friendly Tips (R)

- **Please charge the battery in ventilated or open area. Don't charge the battery in unventilated or closed area.**
- **The charging current is 5A or less. Please don't charge it fast to avoid accident such as battery explosion.**
- **When the battery electrolyte is not enough, you need to replace the battery, please don't add the electrolyte by yourself.**
- **Type of battery on different models may be different. When replacing the battery, please make sure to choose the battery of the same model from the same manufacturer as the original battery.**

### Notice

- ◆ **Before maintenance, please make sure that the engine and all the accessories are closed.**

## Check and replace fuse

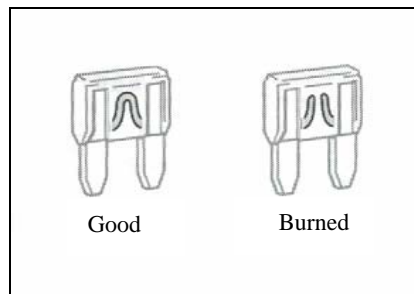

### Model A

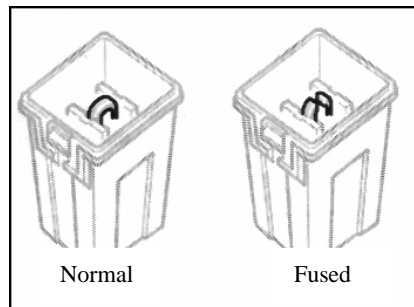

### Model B

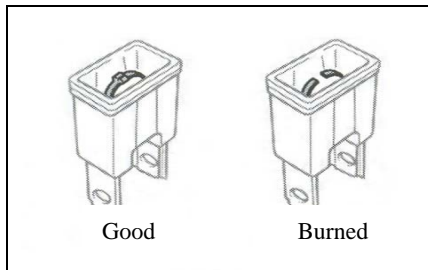

### Model C

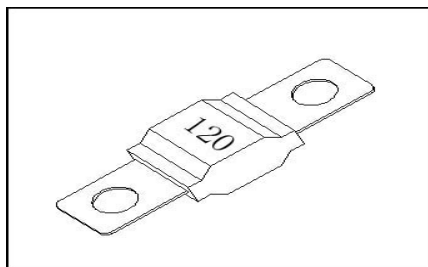

**Model D (check whether it is fused by special instrument)**

**If the headlight or other electrical parts do not work, you should check the fuse. If the fuse has been burned, you should replace it.**

About the location of fuses, you can refer to Section 7-1 “Fuse Arrangement” .

**Disconnect the ignition switch and unworking electrical equipment. Vertically pull out the fuse which may have problem and check it.**

Find out which fuse has problem. There is circuit name of each fuse on the cover of fuse box. The control function of each circuit can be found in Chapter 8 of this manual.

If you are unable to make sure whether the fuse has been burned, you can replace the fuse that may have problem.



You can pull out Model A fuse by the fuse pulling tool. The location of the fuse pulling tool is shown in the figure above.

**If the fuse has been burned, you should install a new fuse to the socket.**

You should only install the fuse of the amperage specified on the fuse box.

If there are no spare fuses, in emergency situation, you can pull out the “DOME” fuse which is dispensable in general driving; if it has the same rating amperage, it can be used as substitute temporarily.

If there is no fuse of the same amperage, you should choose a fuse which has lower amperage; and do try to get a fuse with the amperage as close to the rating amperage as possible. If you use the fuse whose amperage is lower than the specified value, it may be burned again, but this doesn't mean it has a problem. You should install a proper fuse as soon as possible, then put back the substitute fuse in place.

You had better to keep a set of spare fuses in the car for emergency use.

If the new replaced fuse is burned immediately, the electrical system may

have problem. You should go to the service store authorized by BYD for repair.

#### Friendly Tips

- Never use a fuse whose amperage is higher than the rating amperage or use any other objects to replace the fuse, otherwise it may cause serious damage and may lead to fire.

#### Add cleanser

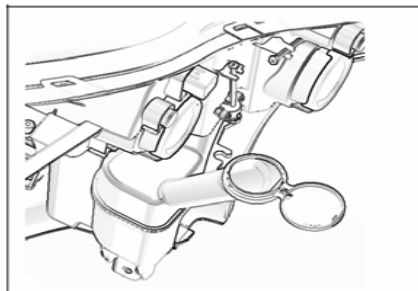

**If the cleaner doesn't work, the cleaner storage tank may have been empty; you should check the cleanser**

**liquid level on the storage tank. If the level is lower, you should add cleanser.**

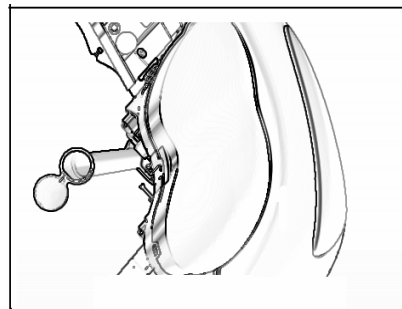

**Pull open the storage tank cover before adding the cleanser.**

You can use water as cleanser. But in cold regions where the temperature is below freezing, you need to use the cleanser with antifreeze. These products are available in the service store authorized by BYD and most auto parts stores. About the mixing ratio with water, you can refer to the instruction of the manufacturer.

Put back the cover of the storage tank after adding the cleanser in it.

## Notice

- ◆ Don't use engine antifreeze or other substitutes, because this will damage the vehicle paint.

## Replace bulb

The following figure shows the method to take out the bulb. When replacing the bulb, please make sure that the ignition switch and light switch have been closed. Please use bulbs with the same rating power as the following table shows.

## Friendly Tips

- When the bulb is hot, please don't replace it to avoid burning.
- The halogen bulb is filled with pressurized gas, you should be particularly careful. If the bulb is scratched or falls to ground, it may explode or crack. You should hold the plastic or metal part of bulb. Don't touch the glass part of bulb with bare hands.

## Notice

- ◆ You should use the bulbs as shown in the following table.

Bulbs	W(watt)	Model
Headlight (low beam)	55	H1
Headlight (high beam)	55	H1
Front fog light	55	H11
Front parking light	5	W5W
Front turn signal light	21	PY21W
Side turn signal light	5	WY5W
Rear turn signal light	21	PY21W
Backup light	21	P21W
Rear fog light	21	PR21W
High brake light	5*4	W5W
License light	5	W5W
Reading light	5	W5W
Brake light/ rear parking light	21/5	P21/5W

When traveling in rain or when the light shade is wet after washing, the inside of lamp shade of external light such as headlight will temporarily fog. As the windshield fogging in rainy days, this fog isn't a trouble as it is due to the temperature difference between the inside and the outside of light shade. But if there is water droplet or water pool in the lightshade, please contact the service store authorized by BYD.

## Low beam light

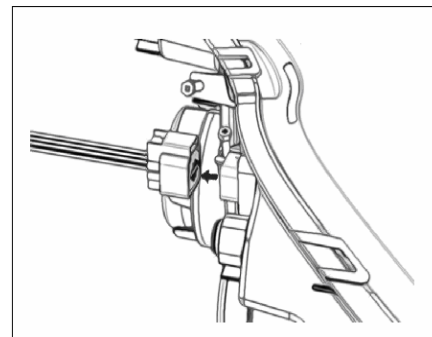

1. Open the engine hood, Unplug the headlight connector.



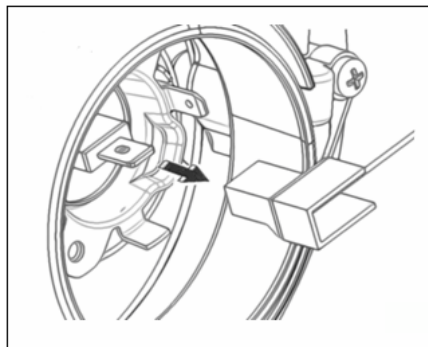
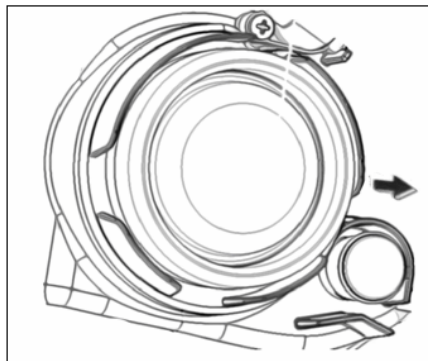

2. **Put out the headlight dustproof sleeve, pull out the Low beam light**

**connector. If the connector is too tight, please twist it.**

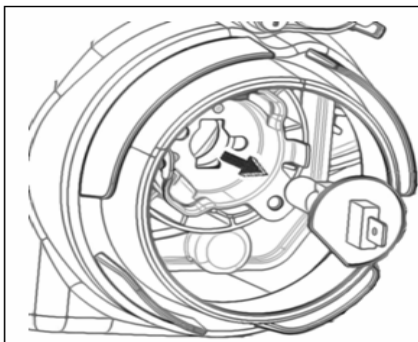
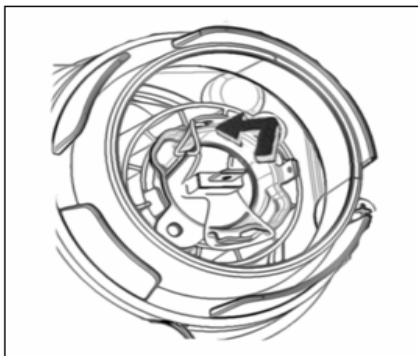

3. **Release the bulb fixing spring and take out the bulb.**
4. **Replace the bulb.**

The steps of installation are opposite to the disassembly.

You don't have to refocus after replacing the bulb. If you need to refocus, please contact the service store authorized by BYD.

**High beam light**

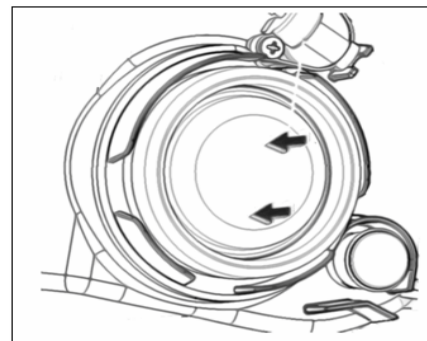

The steps of high beam is the same as the Low beam light, ditto.

## Front parking light



1. Put out the front parking light holder according to the above figure.

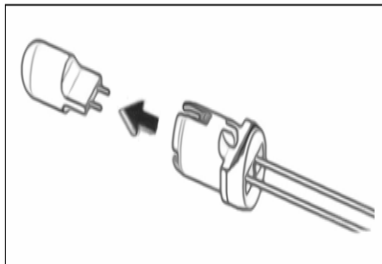

2. Take out the bulb and replace it.

## Front turn signal light



1. Put out the light holder according to the above figure.

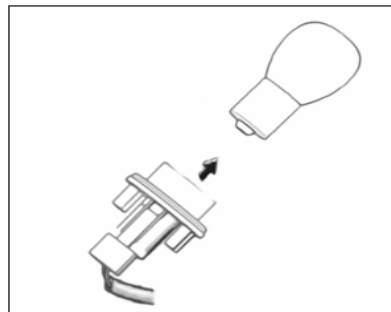

2. Take out the bulb and replace it.

## Side turn signal light

The side turn signal light can't be replaced, if the bulb is damaged, please contact the service store authorized by BYD to replace the assembly of side turn light.

## Rear grouped lights

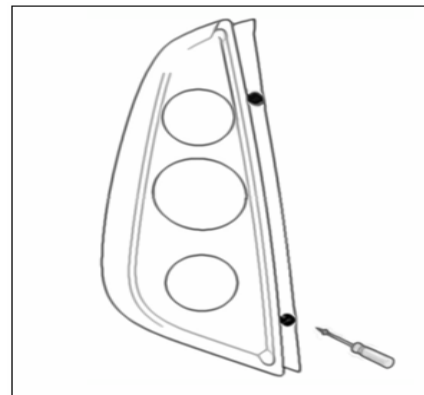

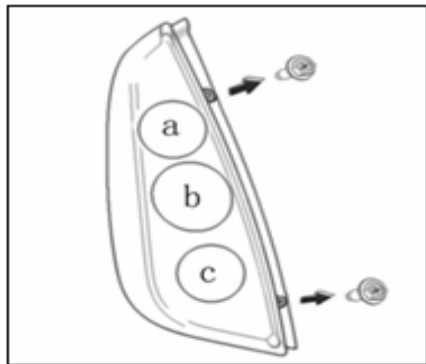

1. Use cross screwdriver to remove the screws. (As shown in the figure above)
  - a. Brake light / taillight
  - b. Rear turn signal light
  - c. Rear fog light (driver side) or backup light (passenger side)

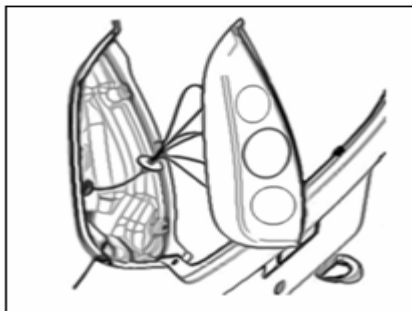

2. Remove the rear grouped light (As shown in the figure above)

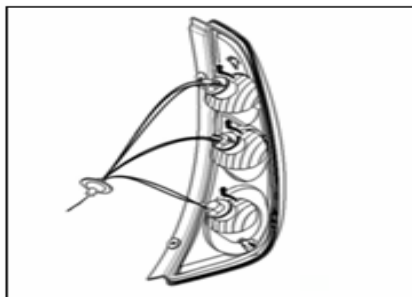

3. Remove the light holder in the rotation direction as shown in the figure above.

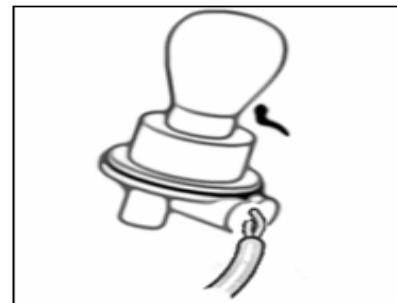

4. Take out the bulb and replace it.

#### High mounted brake light

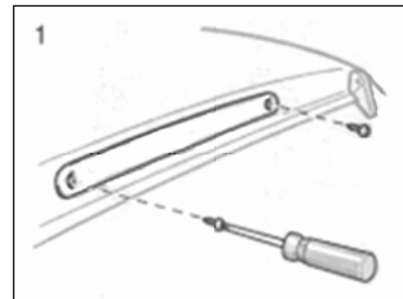

1. Use cross screwdriver to remove the screws.

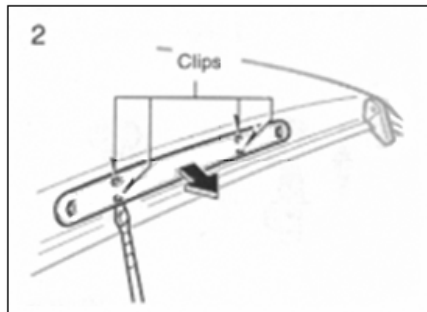

2. Use flat screwdriver to unclench the high mounted brake light.

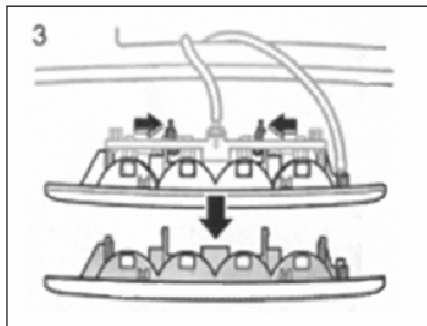

3. Remove the light holder.

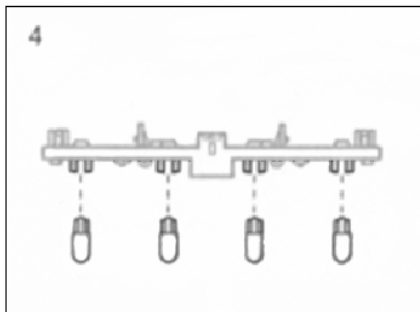

4. Take out the bulb.

The steps of installation is opposite to the disassembly.

#### License light

When replacing the bulb of license light, you should remove the assembly of license light in the rear bumper, then replace the bulb.

#### Friendly Tips

- When plugging in/out the connectors, if you drop the connectors into the installation hole by mistake, please contact the service store authorized by BYD.

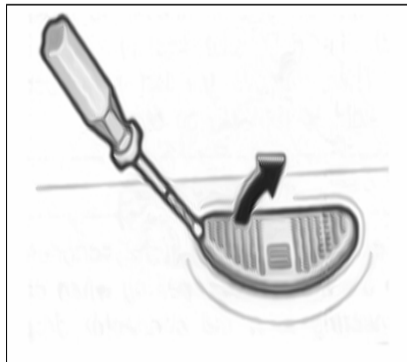

1. Use a small flat screwdriver or the similar tools to unclench the license light.

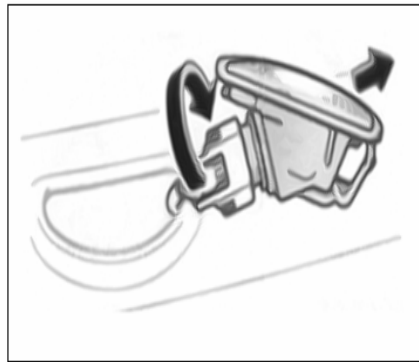

2. Turn the light holder counterclockwise and remove it.

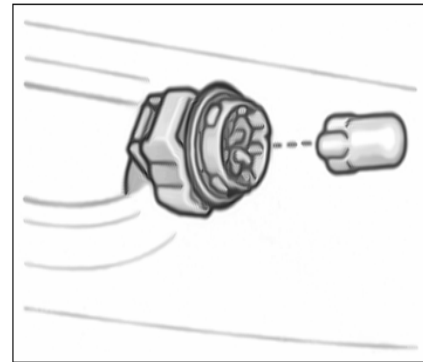

3. Remove the bulb.

The steps of installation are opposite to the disassembly.

## **Chapter 8**

### Chapter 8 Specification of parts

Maintenance specification.....	132
Fuse and relay .....	133

## Maintenance specification

### Engine Lubrication

- **Gasoline engine oil level:**

10W-30/40            above-15°C

5W—30              above-30°C

SG level or above

**Amount:** 3L

- **Specification of gear oil used by the transmission:**

75W—90            above-30°C

80W—90            above-15°C

80W—90            or All year around the  
80W—140           South

API grade GL-4 grade or above.

**Amount:** 1.6-1.7L

- The grease is the lithium base grease which is commonly used by cars.

### Air-condition system

- **Refrigerant specification:**  
HFC-134a

**Amount:** 450g

### Cooling System

- **coolant specification:**  
-25°C, high-quality glycol coolant

**Amount:** 3.5L(Liter)

### Braking System

- **Brake fluid specification:**  
DOT3

**Amount:** 1.0L(Liter)

### Hydraulic steering system

- **Steering fluid specification:**  
ATF DEXRON III

**Amount:** 0.8L(Liter)

### Tires

- **Tire size**  
165/60 R14 75T

- **Tire pressure, KPa**  
220

- **Wheel bolt torque, N·m**  
108

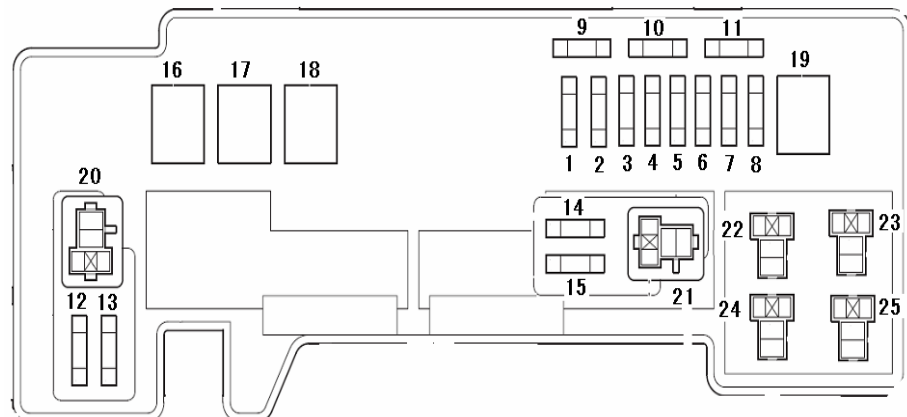

**Fuse and relay**

**(1) Front compartment power distribution**

- 1. Electric horn (10A)
- 2. Warning light (10A)
- 3. Void space
- 4. Void space
- 5. Reading light (15A)
- 6. EFI control (30A)
- 7. Front fog light(15A) (when installed)
- 8. AM2(30A)
- 9. Spare fuse(10A)
- 10. Spare fuse (15A)

- 11. Spare fuse (30A)
- 12. Left front low beam light(10A)
- 13. Left front high beam (10A)
- 14. Right front low beam light(10A)
- 15. Right front high beam (10A)
- 16. ABS (60A) (when installed)
- 17. Void space
- 18. Cooling fan(30A)
- 19. Headlight (40A)
- 20. A/C magnetic clutch relay (when installed)
- 21. Front fog relay(when installed)
- 22. Cooling fan relay
- 23. Electric horn relay
- 24. EFI main relay
- 25. Oil pump relay



## (2) Combination instrument part

### Combination instrument(Right sight)

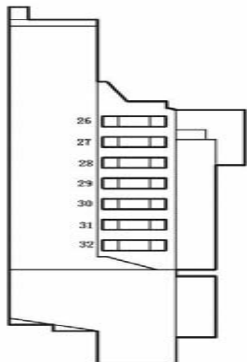

- 26. Spare fuse (7.5A)
- 27. Door lock(25A) (when installed)
- 28. Back Defroster(20A) (when installed)
- 29. Taillight (7.5A)
- 30. Car Diagnosis (7.5A)

- 31. Air-conditioning (7.5A) (when installed)
- 32. Rear fog light (7.5A)

### Combination instrument(Left sight)

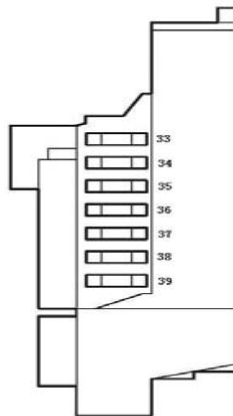

- 33. Audio system ACC (15A)
- 34. IG2(15A)
- 35. Backup light (10A)

- 36. Brake light(10A)
- 37. IG1(15A)
- 38. Windscreen wiper (20A)
- 39. ECU-IG(7.5A)

### Combination instrument(Back)

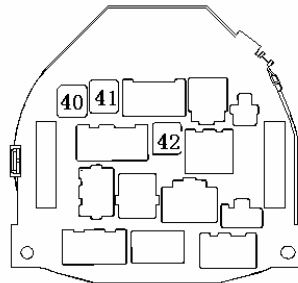

- 40. Power window (30A) (when installed)
- 41. AM1(40A)
- 42. Blower (40A)

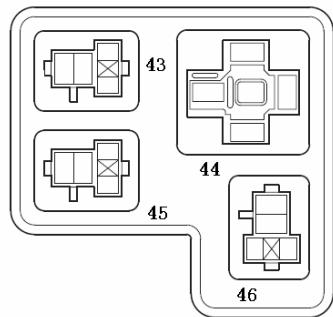
**(1) Instrument panel relay part**

43. ACC Relay

44. Blower Relay

45. IG Relay

46. Back Defroster Relay (when installed)

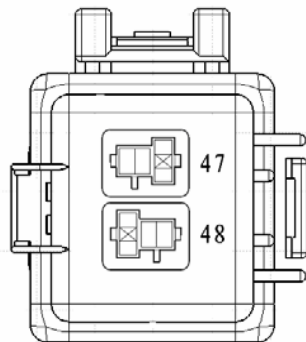
**(2) Front cabin relay part**

47. Low beam light relay

48. Reserved space

