

Chapter 2 Part B:

2.0 litre DOHC engine

Unless otherwise stated, procedures are as described for the SOHC engines in Part A of this Chapter

Contents

Camshafts and cam followers - removal, inspection and refitting . . .21	Engine - refitting (automatic transmission in vehicle)10
Compression test - description and interpretation35	Engine - refitting (manual gearbox in vehicle)9
Crankcase ventilation system - general information2	Engine - removal leaving automatic transmission in vehicle6
Crankshaft and bearings - examination and renovation31	Engine - removal leaving manual gearbox in vehicle5
Crankshaft and main bearings - removal and refitting30	Examination and renovation - general information32
Crankshaft front oil seal - renewal23	Flywheel/driveplate - removal, inspection and refitting22
Crankshaft rear oil seal - renewal24	General information1
Cylinder head - dismantling and reassembly19	Initial start-up after overhaul or major repair34
Cylinder head - inspection and renovation20	Major operations possible with the engine in the vehicle3
Cylinder head - removal and refitting (engine in vehicle)17	Major operations requiring engine removal4
Cylinder head - removal and refitting (engine removed)18	Oil pump - dismantling, inspection and reassembly27
Engine/automatic transmission assembly - reconnection and refitting12	Oil pump drive chain and sprockets - examination and renovation .28
Engine/automatic transmission assembly - removal and separation .8	Oil pump - removal and refitting26
Engine dismantling - general information14	Pistons and connecting rods - removal and refitting29
Engine/manual gearbox assembly - reconnection and refitting . . .11	Sump - removal and refitting25
Engine/manual gearbox assembly - removal and separation7	Timing chain and sprockets - removal and refitting15
Engine mountings - renewal13	Timing chain, sprockets and tensioner - examination and renovation16
Engine reassembly - general information33	

2B

Degrees of difficulty

Easy , suitable for novice with little experience 	Fairly easy , suitable for beginner with some experience 	Fairly difficult , suitable for competent DIY mechanic 	Difficult , suitable for experienced DIY mechanic 	Very difficult , suitable for expert DIY or professional 
---	--	--	---	--

Specifications

General

Manufacturer's code:	
Carburettor engine	N8B
Fuel-injection engine without catalyst	N9B
Fuel-injection engine with catalyst	N9D
Bore - mm (in)	86.00 (3.386)
Stroke - mm (in)	86.00 (3.386)
Cubic capacity - cc (cu in)	1998 (121.9)
Compression ratio	10.3:1
Compression pressure at cranking speed	11 to 13 bar (160 to 189 lbf/in ²)
Maximum power (DIN, kW @ rpm):	
N8B engine	80 @ 5600
N9B engine	92 @ 5500
N9D engine	88 @ 5500
Maximum torque (DIN, Nm @ rpm):	
N8B engine	174 @ 3000
N9B engine	174 @ 2500
N9D engine	171 @ 2500

Lubrication system

Oil type	See "Lubricants and fluids"
Oil capacity:	
With filter	4.5 litres (7.92 pints)
Without filter	4.0 litres (7.04 pints)

2B•2 DOHC engine

Cylinder block

Bore diameter:	
Standard grade 1	86.000 to 86.010 mm
Standard grade 2	86.010 to 86.020 mm
Oversize 0.15 grade A	86.150 to 86.160 mm
Oversize 0.15 grade B	86.160 to 86.170 mm
Oversize 0.5	86.500 to 86.510 mm

Crankshaft

Endfloat	0.090 to 0.300 mm
Main bearing running clearance	0.011 to 0.048 mm
Main bearing journal diameter:	
Standard (yellow)	54.980 to 54.990 mm
Standard (red)	54.990 to 55.000 mm
Undersize 0.25 (green)	54.730 to 54.750 mm
Main bearing thrustwasher thickness:	
Standard	2.301 to 2.351 mm
Oversize 0.38 (yellow)	2.491 to 2.541 mm
Big-end bearing running clearance	0.006 to 0.060 mm
Big-end bearing journal diameter:	
Standard	50.890 to 50.910 mm
Undersize 0.25 (green)	50.640 to 50.660 mm

Pistons and piston rings

Piston diameter:	
Standard 1	85.970 to 85.980 mm
Standard 2	85.980 to 85.990 mm
Standard service	85.980 to 86.000 mm
Oversize 0.15	86.130 to 86.150 mm
Oversize 0.50	86.470 to 86.490 mm
Piston ring end gap:	
Top	0.300 to 0.600 mm
Centre	0.500 to 0.800 mm
Bottom (oil control)	0.400 to 1.500 mm

Cylinder head

Valve guide bore	7.063 to 7.094 mm
Camshaft bearing parent bore diameter	26.000 to 26.030 mm

Camshafts

Endfloat	0.020 to 0.260 mm
----------	-------------------

Valves and valve springs - general

Valve timing:	
Carburettor engine:	
Inlet opens	13°BTDC
Inlet closes	39°ABDC
Exhaust opens	43°BBDC
Exhaust closes	13°ATDC
Fuel-injection engines:	
Inlet opens	13°BTDC
Inlet closes	51°ABDC
Exhaust opens	43°BBDC
Exhaust closes	13°ATDC
Valve spring free length:	
Inner spring	48.200 mm
Outer spring	46.800 mm
Inlet valve stem diameter:	
Standard	7.025 to 7.043 mm
Oversize 0.2	7.225 to 7.243 mm
Oversize 0.4	7.425 to 7.443 mm
Oversize 0.6	7.625 to 7.643 mm
Oversize 0.8	7.825 to 7.843 mm
Exhaust valve stem diameter:	
Standard	6.999 to 7.017 mm
Oversize 0.2	7.199 to 7.217 mm
Oversize 0.4	7.399 to 7.417 mm
Oversize 0.6	7.599 to 7.617 mm
Oversize 0.8	7.799 to 7.817 mm

Torque wrench settings

	Nm	lbf ft
Main bearing cap bolts	90 to 104	66 to 77
Big-end bearing cap bolts:		
Stage 1	6 to 8	4 to 6
Stage 2	15 to 17	11 to 13
Stage 3	Tighten further 85° to 95°	Tighten further 85° to 95°
Crankshaft pulley bolt:		
Stage 1	45 to 58	33 to 43
Stage 2	Tighten further 80° to 90°	Tighten further 80° to 90°
Camshaft sprocket bolts	55 to 63	41 to 46
Flywheel bolts	82 to 92	61 to 68
Oil pump bolts	9 to 12	7 to 9
Oil pump sprocket bolt	16 to 19	12 to 14
Oil pump chain tensioner bolt	10 to 13	7 to 10
Sump bolts and nuts	8 to 10	6 to 7
Sump studs	6 to 8	4 to 6
Sump drain plug	21 to 28	15 to 21
Sump front mounting plate	23 to 28	17 to 21
Oil baffle nuts	17 to 21	13 to 15
Oil pick-up pipe-to-cylinder block bolts	9 to 13	7 to 10
Oil pressure warning lamp switch	18 to 22	13 to 16
Cylinder head bolts:		
M11 bolts:		
Stage 1	25	18
Stage 2	55	41
Stage 3	Tighten further 90°	Tighten further 90°
Stage 4	Tighten further 90°	Tighten further 90°
M8 bolts	36 to 39	27 to 29
Camshaft cover bolts	6 to 8	4 to 6
Camshaft bearing cap nuts	22 to 26	16 to 19
Lower timing chain guide:		
Upper bolt	10 to 13	7 to 10
Lower bolt	24 to 28	18 to 21
Upper and lower timing chain cover bolts	7 to 10	5 to 7
Crankshaft rear oil seal housing bolts	8 to 11	6 to 8
Engine-to-gearbox/transmission bolts	29 to 41	21 to 30

2B

1 General information

The 2.0 litre DOHC (Double OverHead Camshaft) engine was introduced in June 1989 to replace the 2.0 litre SOHC engine used previously in the Granada range, at the same time a 2.0 litre version of the Scorpio model was also introduced. The engine is of four-cylinder, in-line type.

The crankshaft incorporates five main bearings. Thrustwashers are fitted to the centre main bearing in order to control crankshaft endfloat.

The camshafts are driven by a chain from the crankshaft and operate the angled valves via hydraulic cam followers. One camshaft operates the inlet valves, and the other operates the exhaust valves.

The distributor is driven directly from the front of the inlet camshaft, and the oil pump is driven by a chain from the crankshaft. An electric fuel pump is mounted in the fuel tank.

Lubrication is by means of a bi-rotor pump which draws oil through a strainer located inside the sump, and forces it through a full-flow filter into the engine oil galleries, from where it is distributed to the crankshaft and camshafts. The big-end bearings are supplied with oil via internal drillings in the crankshaft. The undersides of the pistons are supplied

with oil from drillings in the connecting rods. The hydraulic cam followers are supplied with oil from passages in the cylinder head. The camshafts are lubricated by oil from spray tubes mounted above the camshaft bearing caps.

A closed crankcase ventilation system is employed, whereby piston blow-by gases are drawn from the crankcase, through a breather pipe into the inlet manifold where they are burnt with fresh air/fuel mixture.

2 Crankcase ventilation system - general information

The crankcase ventilation system (see **illustration**) consists of an oil separator and vent valve fitted to the cylinder block on the left-hand side of the engine. This is connected by a pipe to the inlet manifold. The system operates according to the vacuum in the inlet

2.1 Crankcase ventilation system - fuel-injection engine

- 1 Inlet manifold connection
- 2 Inlet manifold
- 3 Breather pipe
- 4 Oil separator
- 5 Vent valve
- 6 Connecting hose

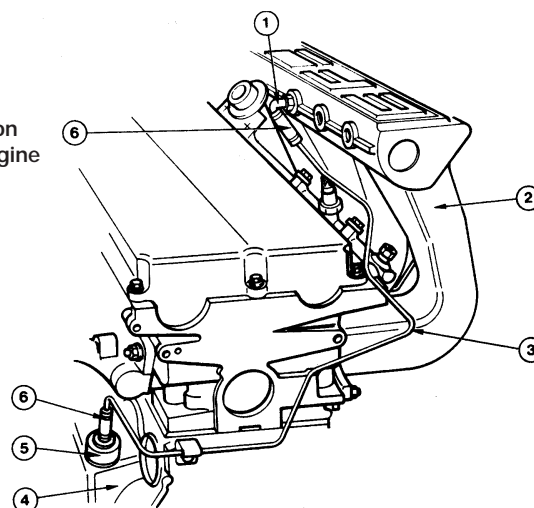

manifold. Piston blow-by gases are drawn through the oil separator and the vent valve to the inlet manifold. The blow-by gases are then drawn into the engine together with the fuel/air mixture. Refer to Chapter 1 for maintenance of the system.

3 Major operations possible with the engine in the vehicle

The following operations can be carried out without removing the engine from the vehicle.

- a) Removal of the camshafts.
- b) Removal and servicing of the cylinder head.
- c) Removal of the timing chain and sprockets.
- d) Removal of the oil pump.
- e) Removal of the sump.
- f) Removal of the pistons and connecting rods.
- g) Removal of the big-end bearings.
- h) Removal of the engine mountings.
- i) Removal of the clutch and flywheel.
- j) Removal of the crankshaft front and rear oil seals.

4 Major operations requiring engine removal

The following operations can only be carried out after removing the engine from the vehicle.

- a) Removal of the crankshaft main bearings.
- b) Removal of the crankshaft.

5 Engine - removal leaving manual gearbox in vehicle



Warning: Vehicles equipped with air conditioning: Components of the air conditioning system may obstruct work being undertaken on the engine, and it is not always possible to unbolt and move them aside sufficiently, within the limits of their flexible pipes. In such a case, the system should be discharged by a Ford dealer or air conditioning specialist. Refer also to the precautions given in Chapter 3.

Note: A hoist and lifting tackle will be required to lift the engine out of the vehicle.

- 1 Disconnect the battery negative lead.
- 2 Remove the bonnet.
- 3 On carburettor models, remove the air cleaner.
- 4 On fuel-injection models, remove the air inlet hose, plenum chamber and air cleaner lid as an assembly.
- 5 Disconnect the breather hose from the camshaft cover, and unscrew the bolt securing the hose support bracket to the left-hand side of the cylinder head (see illustration).
- 6 Drain the cooling system.
- 7 To provide additional working space, remove the radiator.



5.5 Removing the hose support bracket bolt from the cylinder head

8 Disconnect the coolant hoses from the water pump housing on the left-hand side of the engine and the cylinder head (see illustration).

9 Disconnect the coolant hoses from the thermostat housing.

10 Disconnect the heater coolant hose from the inlet manifold.

11 Where applicable, release the coolant hose from the bracket under the carburettor automatic choke housing.

12 Disconnect the throttle cable and (where necessary) speed control cable from the throttle linkage.

13 On carburettor models, disconnect the vacuum pipe from the engine management module.

14 Disconnect the brake servo vacuum hose (where necessary) from the inlet manifold.

15 On fuel-injection models, disconnect the vacuum pipes from the MAP sensor (located on the suspension turret on the right-hand side of the engine compartment) and, where applicable, the air conditioning system.

16 On carburettor models, disconnect the fuel supply and return hoses at the carburettor, and plug the ends of the hoses to minimise petrol spillage. Take adequate fire precautions.

17 On fuel-injection models, slowly loosen the fuel feed union at the fuel rail to relieve the pressure in the fuel system before disconnecting the union. Be prepared for petrol spillage and take adequate fire precautions. Disconnect the fuel feed hose,

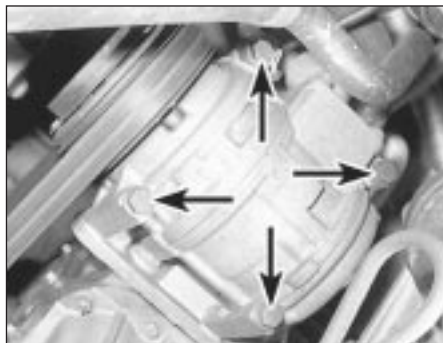

5.21 Air conditioning compressor mounting bolts (arrowed) (viewed from underneath)



5.8 Water pump coolant hoses (viewed from above)

and disconnect the fuel return hose from the fuel pressure regulator. Plug the ends of the hoses to minimise petrol spillage.

18 Disconnect the HT lead from the ignition coil, and unclip it from the timing chain cover.

19 Disconnect the wiring from the following components as applicable, depending on model. Then free the wiring loom from any necessary retaining clips or ties and position it clear of the engine.

- a) Alternator.
- b) Starter motor.
- c) Oil pressure warning lamp switch.
- d) Temperature gauge sender.
- e) Cooling fan switch.
- f) Anti-dieselling valve (carburettor models).
- g) Automatic choke heater (carburettor models).
- h) Engine coolant temperature sensor.
- i) Crankshaft speed/position sensor.
- j) Air charge temperature sensor.
- k) Throttle position sensor.
- l) Fuel temperature sensor.
- m) Fuel injectors.

20 Remove the water pump/alternator drivebelt, then unbolt the power steering pump from the mounting bracket and move it clear of the engine. Note that there is no need to disconnect the fluid hoses, but make sure that the pump is adequately supported to avoid straining them.

21 On models fitted with air conditioning, unbolt the air conditioning compressor from the mounting bracket, and move it clear of the engine (see illustration). Do not disconnect the hoses, but make sure that the compressor is adequately supported to avoid straining them.

22 Unscrew and remove the top engine-to-gearbox bolts which are accessible from the engine compartment. Note the location of the bolts, and the positions of the earth strap and any wiring clips attached to the bolts.

23 Unscrew the securing bolt, and disconnect the earth lead from the rear left-hand side of the cylinder head.

24 Unscrew the nuts securing the engine mountings to the engine mounting brackets.

25 Apply the handbrake, jack up the front of the vehicle and support it securely on axle stands (see "Jacking").

26 Drain the engine oil into a container.



5.29 Intermediate shaft lower clamp bolt (arrowed)



5.33 Engine adaptor plate bolt (arrowed)



5.36 Remove the engine mounting brackets to improve clearance

27 Remove the starter motor.

28 Remove the exhaust downpipe.

29 Ensure that the steering wheel is positioned in the straight-ahead position then, using a dab of paint or a suitable marker pen, make alignment marks between the intermediate shaft lower clamp and steering gear pinion. Slacken and remove the lower clamp bolt then disconnect the intermediate shaft from the steering gear (see illustration).

30 Working inside the vehicle, place a wooden block under the clutch pedal to raise it fully against the stop, so holding the automatic adjuster pawl clear of the toothed quadrant.

31 Disconnect the clutch cable from the clutch release arm, and pass the cable through the bellhousing.

32 Support the gearbox with a trolley jack, using a block of wood between the jack and the gearbox to spread the load.

33 Unscrew and remove the remaining engine-to-gearbox bolts, and remove the bolt from the engine adaptor plate (see illustration). Recover any shims fitted between the sump and the gearbox when removing the lower engine-to-gearbox bolts.

34 Make a final check to ensure that all relevant wires, pipes and hoses have been disconnected and positioned clear of the engine to facilitate engine removal.

35 Attach a suitable hoist to the engine lifting brackets located at the front and rear of the cylinder head, and carefully take the weight of the engine.

36 To improve clearance in the engine compartment when lifting the engine, unbolt the engine mounting brackets from the cylinder block, and remove them (see illustration).

37 Detach the brake lines from the front suspension crossmember (see illustration).

38 Support the crossmember with a jack (do not remove the jack from under the gearbox), then loosen the bolts securing the crossmember to the underbody. Remove the bolts from one side, and carefully lower the crossmember to allow sufficient room for the sump to clear the steering rack and crossmember when pulling the engine forwards from the gearbox (see illustration).



5.37 Removing a brake line securing clip from the suspension crossmember



5.38 Removing a suspension crossmember securing bolt

39 Gently raise the engine, then pull it forwards to disconnect it from the gearbox. Ensure that the gearbox is adequately supported, and take care not to strain the gearbox input shaft.

HAYNES *It may be necessary to rock the engine a little to release it from the gearbox.*
HINT

40 Once clear of the gearbox, lift the engine from the vehicle, taking care not to damage the components in the engine compartment.

6 Engine - removal leaving automatic transmission in vehicle

Note: Refer to Part A, Section 4 of this Chapter and to the warning that appears at the start of Section 5 before proceeding. A suitable hoist and lifting tackle will be required for this operation.

1 Proceed as described in paragraphs 1 to 21 of Section 5.

2 Unscrew and remove the top engine-to-transmission bolts which are accessible from the engine compartment. Note the location of the earth strap, vacuum pipe bracket, and transmission dipstick tube bracket, as applicable.

3 Proceed as described in paragraphs 23 to 29 of Section 5.

4 Where applicable, remove the bolt securing the transmission fluid dipstick tube to the left-hand side of the cylinder block.

5 Working through the starter motor aperture, unscrew the four torque converter-to-driveplate nuts. It will be necessary to turn the crankshaft, using a suitable spanner on the crankshaft pulley bolt, in order to gain access to each bolt in turn through the aperture.

6 Support the transmission with a trolley jack, using a block of wood between the jack and the transmission to spread the load.

7 Unscrew and remove the remaining engine-to-transmission bolts, and remove the bolt from the engine adaptor plate. Recover any shims fitted between the sump and the transmission when removing the lower engine-to-transmission bolts. Where applicable, pull the blanking plug from the adapter plate.

8 Proceed as described in paragraphs 34 to 38 of Section 5.

9 Gently raise the engine, then pull the engine forwards to disconnect it from the transmission. Ensure that the torque converter is held firmly in place in the transmission housing, otherwise it could fall out resulting in fluid spillage and possible damage. It may be necessary to rock the engine a little to release it from the transmission.

10 Once clear of the transmission, lift the engine from the vehicle, taking care not to damage the components in the engine compartment.

7 Engine/manual gearbox assembly - removal and separation



Note: Refer to Part A, Section 4 of this Chapter and to the warning that appears at the start of Section 5 before proceeding. A hoist and lifting tackle will be required for this operation.

- 1 Proceed as described in paragraphs 1 to 21 of Section 5.
- 2 Unscrew the securing bolt, and disconnect the earth lead from the rear left-hand side of the cylinder head.
- 3 Unscrew the nuts securing the engine mountings to the engine mounting brackets.
- 4 Jack up the vehicle and support it securely on axle stands (see "Jacking"). Ensure that there is enough working room beneath the vehicle.
- 5 To improve access, disconnect the exhaust downpipe from the manifold and remove the exhaust system.
- 6 Drain the engine oil into a suitable container.
- 7 On models fitted with a catalytic converter, release the securing clips and withdraw the exhaust heat shield from under the vehicle for access to the propeller shaft.
- 8 Remove the propeller shaft.
- 9 Where applicable, bend back the locktabs, then unscrew the two bolts in each case securing the two anti-roll bar mounting clamps to the vehicle underbody. Lower the anti-roll bar as far as possible.
- 10 Proceed as described in paragraphs 30 and 31 of Section 5.
- 11 Support the gearbox with a trolley jack, using a block of wood between the jack and the gearbox to spread the load.
- 12 Unscrew the four nuts securing the gearbox crossmember to the vehicle underbody. Unscrew the central bolt securing the crossmember to the gearbox, and remove the crossmember. Note the position of the earth strap, where applicable. Recover the mounting cup, and the exhaust mounting bracket and heat shield (as applicable).
- 13 Lower the gearbox slightly on the jack, then remove the circlip, and disconnect the speedometer drive cable from the gearbox.
- 14 Disconnect the wiring from the reversing lamp switch, and on models with fuel-injection, disconnect the wiring from the vehicle speed sensor mounted in the side of the gearbox.
- 15 Slacken and remove the two bolts and washers (one either side) securing the gear linkage support bracket to the gearbox.
- 16 Using a pin punch, drive out the roll pin securing the gearchange rod to the gear linkage.
- 17 Attach a hoist to the engine lifting brackets located at the front and rear of the cylinder head, and slowly take the weight of the engine. Arrange the lifting tackle so that the engine/gearbox assembly will assume a steep angle of approximately 40° to 45° as it is being removed.
- 18 To improve clearance in the engine compartment when lifting the engine, unbolt

the engine mounting brackets from the cylinder block, and remove them.

- 19 Ensure that the steering wheel is positioned in the straight-ahead position then, using a dab of paint or a marker pen, make alignment marks between the intermediate shaft lower clamp and steering gear pinion. Slacken and remove the lower clamp bolt then disconnect the intermediate shaft from the steering gear.
- 20 Detach the brake lines from the front suspension crossmember.
- 21 Support the crossmember with a jack (do not remove the jack from under the gearbox), then loosen the bolts securing the crossmember to the underbody. Remove the crossmember securing bolts, and carefully lower the crossmember to allow sufficient room for the engine sump to clear the steering rack and crossmember as the engine/gearbox assembly is removed.
- 22 Make a final check to ensure that all relevant wires, pipes and hoses have been disconnected to facilitate removal of the engine/gearbox assembly.
- 23 Raise the engine/gearbox, at the same time lowering the trolley jack which is supporting the gearbox.
- 24 Place a suitable rod across the vehicle underbody to support the gear linkage support bracket whilst the gearbox is removed.
- 25 Tilt the engine/gearbox assembly using the hoist and the trolley jack, until the assembly can be lifted from the vehicle. Take care not to damage surrounding components.
- 26 If the vehicle is to be moved, with the engine/gearbox assembly removed, temporarily refit the suspension crossmember and the anti-roll bar to the underbody, and reconnect the steering column to the intermediate shaft.
- 27 To separate the engine from the gearbox, proceed as follows.
- 28 Remove the starter motor.
- 29 Support the engine and gearbox horizontally on blocks of wood.
- 30 Unscrew the engine-to-gearbox bolts, noting the locations of the bolts, and the positions of the earth strap and any wiring clips attached to the bolts. Recover any shims fitted between the sump and the gearbox when removing the lower engine-to-gearbox bolts.
- 31 Unscrew the bolt from the engine adapter plate.
- 32 Pull the engine and gearbox apart, taking care not to strain the gearbox input shaft. It may be necessary to rock the units slightly to separate them.

8 Engine/automatic transmission assembly - removal and separation



Note: Refer to Part A, Section 4 of this Chapter and to the warning that appears at the start of Section 5 before proceeding. A suitable hoist and lifting tackle will be required for this operation. Any suspected faults in the automatic transmission should be referred to a Ford dealer or automatic transmission

specialist before removal of unit, as the specialist fault diagnosis equipment is designed to operate with the transmission in the vehicle.

- 1 Proceed as described in paragraphs 1 to 21 of Section 5.
- 2 Unscrew the securing bolt, and disconnect the earth lead from the rear left-hand side of the cylinder head.
- 3 Unscrew the nuts securing the engine mountings to the engine mounting brackets.
- 4 Jack up the vehicle and support it securely on axle stands (see "Jacking"). Ensure that there is enough working room beneath the vehicle.
- 5 To improve access, disconnect the exhaust downpipe from the manifold and remove the exhaust system.
- 6 Drain the engine oil into a suitable container.
- 7 On models fitted with a catalytic converter, release the securing clips and withdraw the exhaust heat shield from under the vehicle for access to the propeller shaft.
- 8 Remove the propeller shaft.
- 9 Where applicable, bend back the locktabs, then unscrew the two bolts in each case securing the two anti-roll bar mounting clamps to the vehicle underbody. Lower the anti-roll bar as far as possible.
- 10 Support the transmission with a trolley jack, using a block of wood between the jack and the transmission to spread the load.
- 11 Unscrew the four bolts securing the transmission crossmember to the vehicle underbody. Unscrew the central bolt securing the crossmember to the transmission, and remove the crossmember. Note the position of the earth strap, where applicable. Recover the mounting cup, and the exhaust mounting bracket and heat shield (as applicable).
- 12 Lower the transmission slightly on the jack.
- 13 Unscrew the unions and disconnect the fluid cooler pipes from the transmission. Plug the open ends of the pipes and the transmission to prevent dirt ingress and fluid leakage. Where applicable, detach the fluid cooler pipe bracket from the engine mounting bracket, and move it to one side.
- 14 Remove the two clips securing the selector rod, and detach the selector rod from the manual selector lever, and the selector lever on the transmission.
- 15 Disconnect the wiring from the starter inhibitor switch, downshift solenoid, lock-up clutch, reversing lamp switch, and where applicable, the 3rd/4th gearchange solenoid.
- 16 Remove the securing screw, and disconnect the speedometer cable (where fitted) from the transmission extension housing. Plug the opening in the transmission to prevent dirt ingress.
- 17 Proceed as described in paragraphs 17 to 26 of Section 7, substituting transmission for gearbox and ignoring paragraph 24.
- 18 To separate the engine from the transmission, proceed as follows.
- 19 Remove the starter motor.
- 20 Support the engine and transmission horizontally on blocks of wood.

21 Working through the starter motor aperture, unscrew the four torque converter-to-driveplate nuts. It will be necessary to turn the crankshaft using a spanner on the crankshaft pulley bolt in order to gain access to each nut in turn through the aperture.

22 Where applicable, remove the bolt securing the transmission fluid dipstick tube to the left-hand side of the cylinder block.

23 Unscrew the engine-to-transmission bolts, noting the locations of the bolts, and the positions of the earth strap and any wiring clips attached to the bolts. Recover any shims fitted between the sump and the transmission when removing the lower engine-to-transmission bolts.

24 Unscrew the bolt from the engine adapter plate and, where applicable, pull the blanking plug from the adapter plate.

25 Pull the engine and the transmission apart, ensuring that the torque converter is held firmly in place in the transmission housing, otherwise it could fall out resulting in fluid spillage and possible damage. It may be necessary to rock the units slightly to separate them.

9 Engine - refitting (manual gearbox in vehicle)



1 Reverse the procedure described in paragraphs 1 to 40 of Section 5, noting the following points.

2 Before attempting to refit the engine, check that the clutch friction disc is centralised.

3 Check that the clutch release arm and bearing are correctly fitted, and lightly grease the input shaft splines.

4 Check that the engine adapter plate is correctly positioned on the locating dowels. If necessary, a cable-tie can be used to temporarily secure the adapter plate in position on the cylinder block using one of the engine-to-gearbox bolt holes.

5 If shims were fitted between the sump and the gearbox, refit them in their original locations when mating the engine to the gearbox. If the engine has been overhauled, where applicable fit the relevant shims as calculated during engine reassembly.

6 Reconnect the clutch cable to the release arm, ensuring that it is routed as noted during removal.

7 Ensure that the roadwheels and the steering wheel are in the straight-ahead position then align the marks made on removal and reconnect the intermediate shaft to the steering gearing. Tighten the clamp bolt to the specified torque.

8 Refit the exhaust downpipe.

9 Fill the engine with the correct grade and quantity of oil.

10 Check the throttle cable adjustment. Where necessary, also adjust the speed control cable in the same way so that there is only a small amount of slack present in the cable.

11 Reconnect the coolant hoses to the water pump housing.

12 Fill the cooling system.

13 Tighten all fixings to the specified torque, where applicable.

10 Engine - refitting (automatic transmission in vehicle)



1 Reverse the procedure described in Section 6, noting the following points.

2 Check that the engine adapter plate is correctly positioned on the locating dowels. If necessary, a cable-tie can be used to temporarily secure the adapter plate in position on the cylinder block using one of the engine-to-transmission bolt holes.

3 As the torque converter is only loosely engaged in the transmission, care must be taken to prevent the torque converter from falling out forwards. When the torque converter hub is fully engaged with the fluid pump drivegear in the transmission, distance A (see illustration 2.20 in Chapter 7B) must be as specified. Incorrect installation of the torque converter will result in damage to the transmission.

4 If shims were fitted between the sump and the transmission, refit them in their original locations when mating the engine to the transmission. If the engine has been overhauled, where applicable fit the relevant shims as calculated during engine reassembly.

5 As the engine is installed, guide the torque converter studs through the holes in the driveplate. When the engine is positioned flush with the engine adapter plate and the transmission housing, check that the torque converter is free to move axially a small amount before refitting and tightening the engine-to-transmission bolts.

6 Do not tighten the torque converter-to-driveplate nuts until the lower engine-to-transmission bolts have been fitted and tightened.

7 Ensure that the roadwheels and the steering wheel are in the straight-ahead position then align the marks made on removal and reconnect the intermediate shaft to the steering gearing. Tighten the clamp bolt to the specified torque.

8 Refit the exhaust downpipe.

9 Fill the engine with the correct grade and quantity of oil.

10 Check the throttle cable adjustment. Where necessary, also adjust the speed control cable in the same way so that there is only a small amount of slack present in the cable.

11 Reconnect the coolant hoses to the water pump housing.

12 Fill the cooling system.

13 Tighten all fixings to the specified torque, where applicable.

11 Engine/manual gearbox assembly - reconnection and refitting



1 Reverse the procedure described in Section 7, noting the following points.

2 Before attempting to reconnect the engine to the gearbox, check that the clutch friction disc is centralised.

3 Check that the clutch release arm and

bearing are correctly fitted, and lightly grease the input shaft splines.

4 Check that the engine adapter plate is correctly positioned on the locating dowels. If necessary, a cable-tie can be used to temporarily secure the adapter plate in position on the cylinder block using one of the engine-to-gearbox bolt holes.

5 If shims were fitted between the sump and the gearbox, refit them in their original locations when mating the engine to the gearbox. If the engine has been overhauled, where applicable fit the relevant shims as calculated during engine reassembly.

6 Ensure that the roadwheels and the steering wheel are in the straight-ahead position then align the marks made on removal and reconnect the intermediate shaft to the steering gearing. Tighten the clamp bolt to the specified torque.

7 Reconnect the clutch cable to the release arm, ensuring that it is routed as noted during removal.

8 Refit the propeller shaft.

9 Refit the exhaust system.

10 Fill the engine with the correct grade and quantity of oil.

11 Check the throttle cable adjustment. Where necessary, also adjust the speed control cable in the same way so that there is only a small amount of slack present in the cable.

12 Reconnect the coolant hoses to the water pump housing.

13 Fill the cooling system.

14 Check and if necessary top-up the gearbox oil level.

15 Tighten all fixings to the specified torque, where applicable.

12 Engine/automatic transmission assembly - reconnection and refitting



1 Reverse the procedure described in Section 8, noting the following points.

2 Check that the engine adapter plate is correctly positioned on the locating dowels. If necessary, a cable-tie can be used to temporarily secure the adapter plate in position on the cylinder block using one of the engine-to-transmission bolt holes.

3 As the torque converter is only loosely engaged in the transmission, care must be taken to prevent the torque converter from falling out forwards. When the torque converter hub is fully engaged with the fluid pump drivegear in the transmission, distance A (see illustration 2.20 in Chapter 7B) must be as specified. Incorrect installation of the torque converter will result in damage to the transmission.

4 If shims were fitted between the sump and the transmission, refit them in their original locations when mating the engine to the transmission. If the engine has been overhauled, where applicable fit the relevant shims as calculated during engine reassembly.

5 As the engine and transmission are mated

2B•8 DOHC engine

together, guide the torque converter studs through the holes in the driveplate. When the engine is positioned flush with the engine adapter plate and the transmission housing, check that the torque converter is free to move axially a small amount before refitting and tightening the engine-to-transmission bolts.

6 Do not tighten the torque converter-to-driveplate nuts until the lower engine-to-transmission bolts have been fitted and tightened.

7 Ensure that the roadwheels and the steering wheel are in the straight-ahead position then align the marks made on removal and reconnect the intermediate shaft to the steering gearing. Tighten the clamp bolt to the specified torque.

8 Reconnect the selector rod and adjust as described in Chapter 7, Part B.

9 Refit the propeller shaft.

10 Refit the exhaust system.

11 Fill the engine with the correct grade and quantity of oil.

12 Check the throttle cable adjustment. Where necessary, also adjust the speed control cable in the same way so that there is only a small amount of slack present in the cable.

13 Reconnect the coolant hoses to the water pump housing.

14 Fill the cooling system.

15 Check and if necessary top-up the transmission fluid level.

16 Tighten all fixings to the specified torque, where applicable.

13 Engine mountings - renewal

Proceed as described in Part A, Section 23 of this Chapter but note that on certain models, it may be necessary to unbolt the engine mounting brackets from the cylinder block to allow sufficient clearance to remove the mountings.

14 Engine dismantling - general information

1 Refer to Part A, Section 8 of this Chapter, paragraphs 1 to 8 inclusive.

2 A selection of splined and Torx sockets will be required to remove many of the bolts when dismantling the engine.

3 Before dismantling the main engine components, the following externally mounted ancillary components can be removed.

- Inlet manifold (and carburettor, where applicable).
- Exhaust manifold.
- Alternator.
- Water pump, and thermostat.
- Water pump/alternator drivebelt tensioner.
- Distributor cap, HT leads and spark plugs.
- Oil pressure warning lamp switch.
- Crankshaft speed/position sensor.
- Oil filter.
- Dipstick.
- Engine mounting brackets (if not already done).
- Crankcase ventilation pipe and hoses.

- Clutch.
- Alternator mounting bracket.
- Air conditioning compressor mounting bracket (where applicable).
- Engine lifting brackets.

15 Timing chain and sprockets - removal and refitting

Note: A puller will be required to remove the crankshaft pulley. A new crankshaft pulley bolt, a new timing chain tensioner plunger assembly, new upper and lower timing chain cover gaskets and a new camshaft cover gasket and reinforcing sleeve sealing rings must be used on refitting.

1 If the engine is in the car, carry out the

following operations.

- Disconnect the battery negative lead.
- To improve access, remove the radiator. It will be difficult to remove the crankshaft pulley with the radiator in place.
- On carburettor models, remove the air cleaner.
- On fuel-injection models, remove the air inlet hose, plenum chamber and air cleaner lid as an assembly.
- Disconnect the breather hose from the camshaft cover.
- Remove the distributor cap and HT leads, and the rotor arm and housing.

2 Proceed as described in paragraphs 2 to 11 inclusive of Section 18 (see illustration).

3 Remove the water pump/alternator drivebelt.

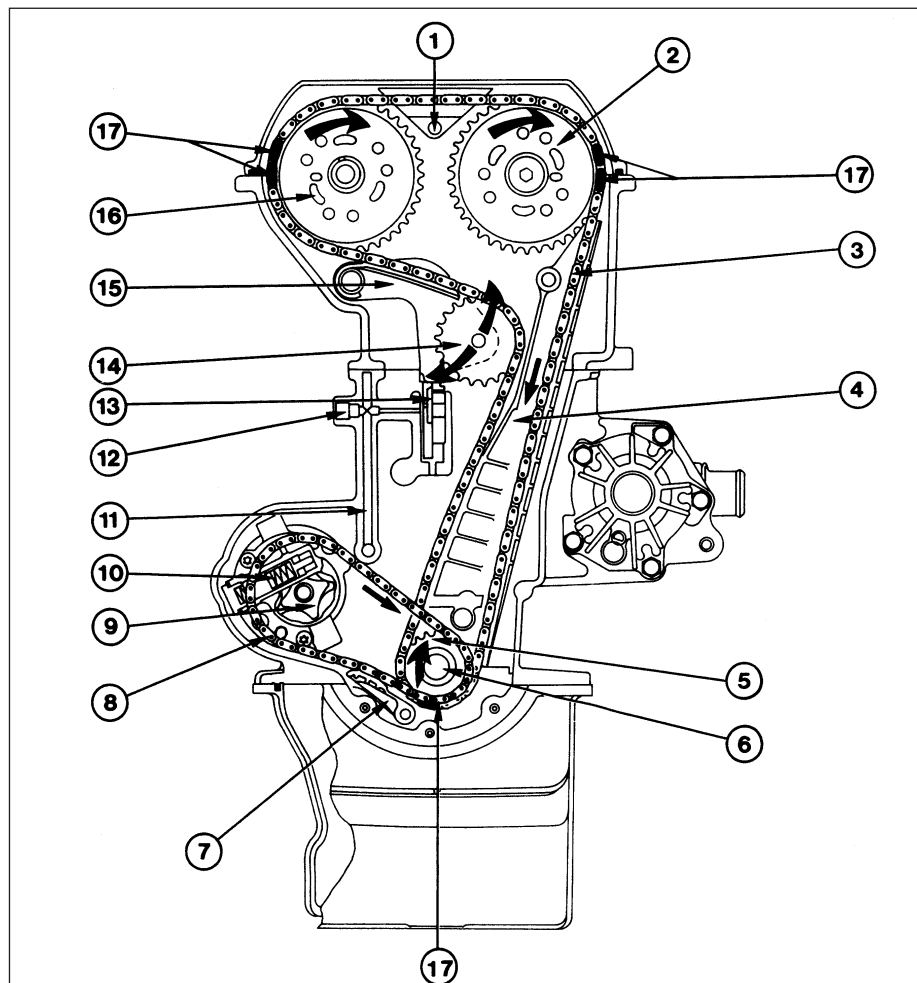

15.2 Timing chain, oil pump drive chain and associated components

- | | |
|--------------------------------|--|
| 1 Upper timing chain guide | 10 Oil pressure relief valve |
| 2 Exhaust camshaft sprocket | 11 Oil passage to timing chain tensioner plunger |
| 3 Timing chain | 12 Plug |
| 4 Lower timing chain guide | 13 Timing chain tensioner plunger |
| 5 Crankshaft sprocket (double) | 14 Timing chain tensioner sprocket |
| 6 Crankshaft | 15 Timing chain tensioner arm |
| 7 Oil pump chain tensioner | 16 Inlet camshaft sprocket |
| 8 Oil pump drive chain | 17 Copper chain links |
| 9 Oil pump | |



15.5a Using a puller to remove the crankshaft pulley (viewed from underneath vehicle)

4 Slacken the crankshaft pulley bolt. Prevent the crankshaft from turning by engaging top gear (manual gearbox only) and having an assistant press the brake pedal hard, or by removing the starter motor and jamming the ring gear teeth with a lever.

5 Unscrew the bolt part way, and use a suitable legged-puller to draw the crankshaft pulley off the crankshaft. The legs of the puller must be suitably shaped to enable them to rest on the metal surfaces of the pulley. **Note:** Do not attempt to remove the pulley with a puller whose legs contact the rubber surface of the pulley (see illustrations). Note that a new crankshaft pulley retaining bolt will be required for refitting.

6 Loosen the alternator lower mounting

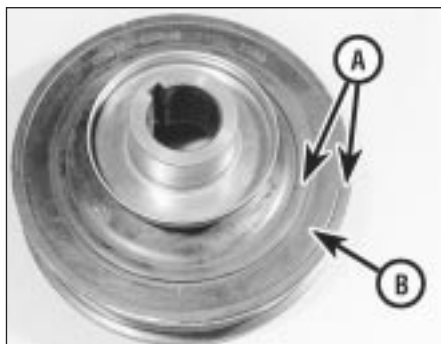

15.5b Position the legs of the puller on the metal surfaces of the pulley (A), not the rubber surface (B)

through-bolt, then remove the alternator upper mounting bolt, and swing the alternator away from the engine.

7 Unscrew the central securing bolt, and withdraw the drivebelt tensioner assembly.

8 Unscrew the eleven securing bolts, and remove the lower timing chain cover. Remove the rubber gasket and discard it; a new one must be used on refitting.

9 Using a suitable Torx socket, unscrew the securing screw, and carefully withdraw the oil pump chain tensioner (see illustration).

10 Unscrew the Torx type securing bolt, and withdraw the oil pump sprocket, complete with the oil pump drive chain.

11 Unscrew the two Torx bolts securing the lower timing chain guide, noting their



15.9 Oil pump chain tensioner securing screw (arrowed)

locations, and withdraw the timing chain guide through the top of the timing case (see illustrations).

12 Remove the Woodruff key from the end of the crankshaft, prising it free with a screwdriver if necessary, then slide the double chain sprocket from the end of the crankshaft, and lift the chain from the sprocket (see illustration).

13 Withdraw the timing chain through the top of the timing case and, where applicable, remove the cable-tie from the chain (see illustration).

14 The timing chain, sprockets and tensioner can now be examined for wear and damage.

15 Commence refitting as follows. Note that coppered links are provided in the timing chain to assist with refitting, but these can be difficult to see on a chain which has already been in service. If possible, position the coppered links as described during the following procedure. If the coppered links are not visible, the chain should still be refitted as described, but ignore the references to the coppered links.

16 Make sure that the slot for the Woodruff key in the end of the crankshaft is pointing vertically downwards. If necessary, temporarily refit the crankshaft pulley bolt in order to turn the crankshaft to the required position.

17 Lower the timing chain into the timing case from above, with the single coppered link at the bottom. If desired, use a cable-tie to



15.11a Lower timing chain guide upper securing bolt (arrowed)



15.11b Lower timing chain guide lower securing bolt (arrowed)



15.11c Withdrawing the lower timing chain guide



15.12 Sliding the double chain sprocket from the end of the crankshaft



15.13 Withdrawing the timing chain through the top of the timing case



15.19 Coppered link in timing chain aligned with crankshaft sprocket timing mark (arrowed)



15.31 Fitting a new lower timing chain cover oil seal

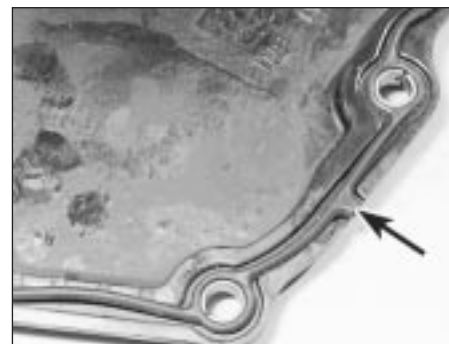

15.32 Lower timing chain cover gasket in position. Ensure that lug on gasket engages with notch in cover (arrowed)

prevent the chain from dropping into the timing case, as during removal.

18 Locate the double chain sprocket loosely over the end of the crankshaft (larger sprocket nearest the crankcase), with the timing mark pointing vertically down.

19 Fit the chain over the inner, larger sprocket, aligning the coppered link in the chain with the timing mark on the sprocket (see illustration).

20 Coat the threads of the lower timing chain guide lower securing bolt with a suitable thread-locking compound.

21 Introduce the lower timing chain guide through the top of the timing case, manipulating the chain around the guide as necessary, then fit the chain guide lower securing bolt and tighten it finger-tight.

22 Push the double chain sprocket onto the crankshaft, engaging the notch in the sprocket with the groove in the end of the crankshaft.

23 Proceed as described in paragraphs 34 to 42 of Section 18, but when fitting the chain over the camshaft sprockets, align the timing mark on each sprocket between the two corresponding coppered links in the chain.

24 Coat the threads of the lower timing chain guide upper securing bolt with a suitable thread-locking compound, then fit the bolt and tighten it finger-tight.

25 Proceed as described in paragraphs 43 to 46 of Section 18.

26 Tighten the two chain guide securing bolts to the specified torque.

27 Proceed as described in paragraphs 47 to 55 of Section 18.

28 Fit the oil pump drive chain around the outer crankshaft sprocket and the oil pump sprocket, then refit the oil pump sprocket, and tighten the securing bolt to the specified torque. If necessary, a screwdriver can be inserted through one of the holes in the sprocket to prevent it from turning as the securing bolt is tightened.

29 Refit the oil pump drive chain tensioner, and tighten the securing bolt to the specified torque.

30 Refit the Woodruff key to the end of the crankshaft.

31 Inspect the oil seal in the lower timing chain cover. If the oil seal is in good condition,

the cover can be refitted as follows, but if the seal is damaged, or has been leaking, a new seal should be fitted to the cover. If necessary, carefully prise the old oil seal from the cover using a screwdriver, and drive in the new seal using a suitable metal tube. Make sure that the seal lip faces into the engine. Note that the oil seal should be fitted dry. Take care not to damage the timing chain cover (see illustration).

32 Fit the lower timing chain cover using a new rubber gasket (see illustration).

33 Loosely refit the timing chain cover securing bolts.

34 Refit the crankshaft pulley to the end of the crankshaft, and draw the pulley onto the crankshaft using the original securing bolt, at the same time centering the lower timing chain cover.

35 With the lower timing chain cover centralised, and the pulley fully home on the crankshaft, remove the old securing bolt, then fit a new bolt.

36 Tighten the new crankshaft pulley bolt to the specified torque, in the two stages given in the Specifications at the beginning of this Chapter. Prevent the crankshaft from turning as during removal.

37 Tighten the lower timing chain cover securing bolts to the specified torque.

38 Refit the drivebelt tensioner assembly, ensuring that the lug on the rear of the tensioner bracket engages with the corresponding hole in the cylinder block, and tighten the securing bolt.



17.5 Disconnecting the heater coolant hose from the inlet manifold

39 Swing the alternator into position to align the upper mounting bolt hole with the corresponding hole in the drivebelt tensioner assembly, then refit the upper mounting bolt, and tighten the upper bolt and the lower through-bolt.

40 Refit the water pump/alternator drivebelt.

41 If the engine is in the vehicle, reverse the operations described in paragraph 1 of Section 15.

42 Where applicable, refill the cooling system.

16 Timing chain, sprockets and tensioner - examination and renovation

1 Examine all the teeth on the camshaft and crankshaft sprockets. If the teeth are "hooked" in appearance, renew the sprockets.

2 Examine the chain tensioner plastic sprocket for wear. If excessive wear is evident, the complete tensioner assembly must be renewed as the sprocket cannot be renewed independently. Note that the tensioner plunger assembly must be renewed whenever the timing chain is removed.

3 Examine the timing chain for wear. If the chain has been in operation for a considerable time, or if when held horizontally (rollers vertical) it takes on a deeply bowed appearance, renew it.

17 Cylinder head - removal and refitting (engine in vehicle)

Note: The cylinder head must not be removed when the engine is warm. Refer to the note at the beginning of the following Section before proceeding.

1 Disconnect the battery negative lead.

2 On carburettor models, remove the air cleaner.

3 On fuel-injection models, remove the air inlet hose, plenum chamber, and air cleaner lid as an assembly.

4 Drain the cooling system.

5 Disconnect the heater coolant hose from the inlet manifold (see illustration).



17.6 Hose bracket bolted to cylinder head (arrowed)

6 Disconnect the breather hose from the camshaft cover, and unbolt the hose bracket from the left-hand side of the cylinder head (see illustration).

7 Unscrew the securing bolt and disconnect the earth lead from the left-hand rear of the cylinder head.

8 Remove the distributor cap and HT leads, and the rotor arm and housing, as applicable. If necessary, mark the HT leads to aid refitting.

9 The cylinder head can be removed either with or without the manifolds and fuel rail, where applicable (it is easiest to remove the head complete with the manifolds and fuel rail). If desired, the inlet manifold and the fuel rail can be unbolted and moved to one side, leaving the wires, hoses, pipes and cables connected, but care must be taken not to place any strain on them.

10 Unscrew the three securing nuts and disconnect the exhaust downpipe from the manifold. It may be necessary to jack up the front of the vehicle to gain access to the nuts (in which case apply the handbrake and support the front of the vehicle securely on axle stands) (see "Jacking"). Discard the gasket.

11 If the inlet manifold and the fuel rail (where applicable) are to be removed with the cylinder head, disconnect all relevant wires, hoses, pipes and cables, otherwise, unbolt the manifold and the fuel rail, and move them to one side, ensuring that they are adequately supported. If the fuel rail is unbolted, be prepared for fuel spillage, and take adequate fire precautions.

12 Refer to the procedure described in paragraphs 2 to 19 of Section 18 to complete cylinder head removal.

13 Commence refitting by referring to paragraphs 20 to 55 of Section 18, then reverse the procedure described in paragraphs 1 to 11 of this Section, noting the following points.

- Use a new gasket when reconnecting the exhaust downpipe to the manifold.
- Ensure that the HT leads are reconnected correctly.
- Fill the cooling system.



18.0 Use new M8 (auxiliary) cylinder head bolts with hexagonal heads (A), not the earlier Torx type bolts (B)

18 Cylinder head - removal and refitting (engine removed)

Note: New cylinder head bolts, a new cylinder head gasket, a new timing chain tensioner plunger assembly, a new upper timing chain cover gasket, and a new camshaft cover gasket and reinforcing sleeve sealing rings must be used on refitting. It is essential that the three smaller M8 bolts are of the latest type with hexagonal heads, not the earlier Torx type (see illustration).

1 With the manifolds removed, proceed as follows.

2 Unscrew the eleven bolts and four nuts, and remove the camshaft cover. Recover the gasket.

3 Unscrew the four securing bolts and three studs, and remove the upper timing chain cover. Note the locations of the studs to aid refitting.

4 Using a spanner on the crankshaft pulley, turn the crankshaft to bring No 1 piston to the firing point (TDC). With No 1 piston at the firing point, the timing marks on the camshaft sprockets should be pointing away from each other, and should be approximately level with the top edge of the cylinder head. Timing notches are provided in the camshaft sprockets, and corresponding paint marks are provided on the outside edges of the sprockets (see illustration).

5 Hold the inlet camshaft sprocket stationary using a peg spanner which engages with the



18.5 Removing the inlet camshaft sprocket bolt and the distributor rotor shaft

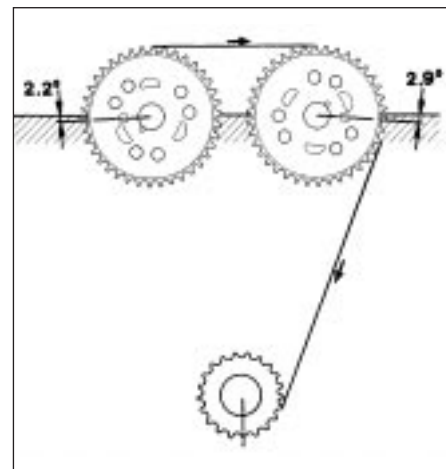

18.4 Timing mark positions with No 1 cylinder at TDC

spokes of the camshaft sprocket. Unscrew the camshaft sprocket bolt, and remove the distributor rotor shaft (see illustration).

HAYNES HiNT If a peg spanner is not available, a tool can be made from two lengths of steel strip (one long, the other short) and three nuts and bolts; one nut and bolt forming the pivot of a forked tool with the remaining two nuts and bolts at the tips of the "forks" to engage with the sprocket spokes.

6 Repeat the procedure given in paragraph 5 for the exhaust camshaft, but note that a spacer is fitted in place of the distributor rotor shaft.

7 Squeeze the upper timing chain guide securing lugs together, using pliers if necessary, and withdraw the guide from the plate at the front of the cylinder head (see illustration).

8 Mark the position of the timing chain in relation to the camshaft sprockets, so that the chain can be refitted in precisely its original position (ie, make alignment marks between each sprocket and a corresponding link in the chain), then slide the camshaft sprockets from the camshafts. Withdraw the sprockets and lay the timing chain over the exhaust side of the timing case, having eliminated the slack in



18.7 Upper timing chain guide securing lugs (arrowed)



18.9 Removing the chain tensioner arm pivot pin circlip

the chain. Secure the chain using a cable-tie through two of the chain links to prevent it from dropping off the crankshaft sprocket.

9 Using a suitable pair of pliers, extract the circlip from the chain tensioner arm pivot pin, taking care not to drop it into the timing case, then withdraw the pivot pin from the tensioner arm. If the pivot pin proves difficult to withdraw, an M6 bolt can be screwed into the end to facilitate removal (see illustration).

10 Lift the tensioner arm from the timing case.
11 Lift the tensioner plunger assembly from the cylinder head, and discard it (see illustration).



Warning: Take care when removing the plunger assembly; injury could result if the piston flies out. A new timing chain tensioner plunger assembly should be installed on refitting.



18.11 Lifting the chain tensioner plunger assembly from the cylinder head

12 Take note of the markings on the camshaft bearing caps, then progressively unscrew the bearing cap securing nuts.

13 Remove the bearing cap securing nuts, then lift off the camshaft oil spray bars, and the timing chain guide plate (see illustration).

14 Lift off the bearing caps, and then lift out the two camshafts (see illustrations).

HAYNES HINT The inlet camshaft is normally identified by a green paint mark. If necessary, identify the camshafts so that they can be refitted in their correct positions.

15 Withdraw the cam followers from their locations in the cylinder head, keeping them in order so that they can be refitted in their

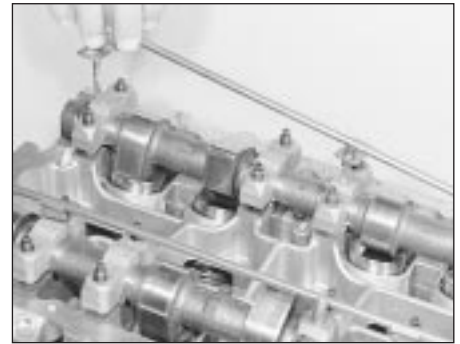

18.13 Lifting off a camshaft oil spray bar

original locations (see illustration). It is advisable to store the cam followers upright in an oil bath until they are to be refitted. Ensure that the depth of oil is sufficient to fully cover the cam followers.

16 Working at the front of the cylinder head, unscrew the three small M8 cylinder head bolts which are accessible through the timing case (see illustration).

17 Working in the reverse order to that shown for tightening the cylinder head bolts (see illustration), progressively loosen the remaining cylinder head bolts, and withdraw them from the cylinder head.

18 Lift the cylinder head from the block. If the cylinder head is stuck, tap it free with a soft-faced mallet. Do not insert a lever into the joint between the cylinder head and block, as this may result in damage to the mating faces. Place the cylinder head on blocks of wood to prevent damage to the valves.

19 Recover the gasket, and the locating dowels if they are loose, noting the positions of the locating dowels.

20 Commence refitting as follows.

21 Turn the crankshaft so that No 1 piston is approximately 20.0 mm (0.8 in) before TDC. This precaution will prevent possible contact between the valves and pistons.

22 Make sure that the mating faces of the cylinder block and cylinder head are perfectly clean, then refit the locating dowels (where applicable) and locate a new gasket over the



18.14a Lifting off a camshaft bearing cap

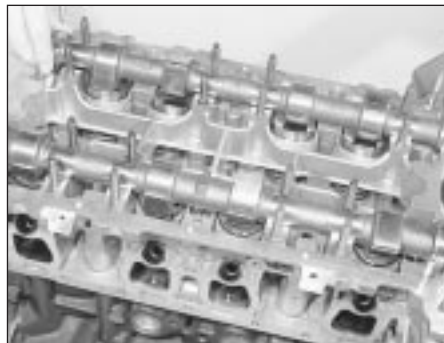

18.14b Lifting out the exhaust camshaft



18.15 Withdrawing a cam follower



18.16 M8 cylinder head bolts (arrowed) located at front of cylinder head

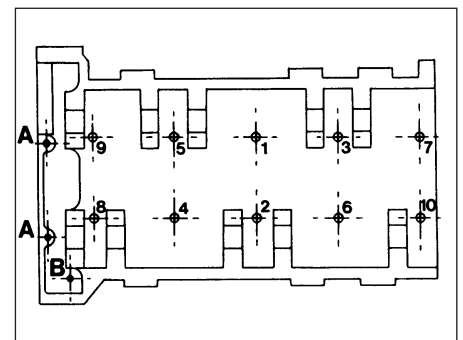

18.17 Cylinder head bolt tightening sequence

A Long M8 bolts

B Short M8 bolt



18.22 Fitting a new cylinder head gasket

dowels. Note that the gasket can only fit in one position (see illustration). Do not use jointing compound.

23 Lower the cylinder head onto the gasket, making sure that the locating dowels engage.

24 Oil the threads of the new main cylinder head bolts, and insert them into their locations in the cylinder head.

25 Tighten the bolts in the order shown (see illustration) and in the four stages given in the Specifications.

26 Insert the three smaller M8 cylinder head bolts through the top of the timing case (see illustration) and tighten them to the specified torque. Note that new bolts must be used, and that they should be of the latest type with hexagonal heads.

27 Lubricate the cam follower bores in the cylinder head, and the cam followers themselves, then insert the cam followers into their original locations in the cylinder head.

28 Lubricate the camshaft bearing surfaces in the cylinder head and the bearing caps.

29 Lubricate the surfaces of the camshafts, then carefully lay the camshafts in their original positions in the cylinder head. Position the camshafts with the slots in their front ends pointing away from each other.

30 Fit the bearing caps L1, L3, L5, R1, R3, and R5 (see illustration), then lay the camshaft oil spray bars and the timing chain guide plate in position over the studs (see illustrations).



18.30c Fitting the timing chain guide plate

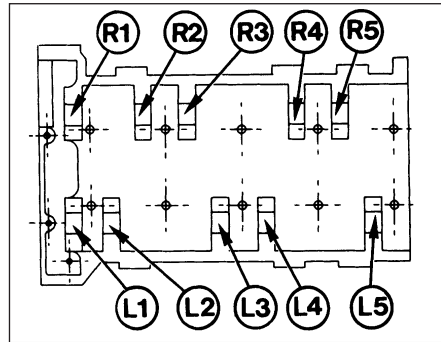

18.30a Camshaft bearing cap tightening sequence

31 Carefully tighten the bearing cap securing nuts by hand in the following stages to lower the camshafts into position.

Tighten the nuts for bearing caps L1 and R1 by half-a-turn (180°)

Tighten the nuts for bearing caps L5 and R5 by half-a-turn (180°)

Tighten the nuts for bearing caps L3 and R3 by half-a-turn (180°)

Continue to tighten the nuts in the small stages given until the bearing caps contact the cylinder head.

32 Fit bearing caps L2, L4, R2 and R4, and tap them into position on the cylinder head using light taps from a soft-faced mallet. Tighten the securing nuts evenly by hand.

33 Tighten all the bearing cap nuts to the specified torque in half turn stages, using the following sequence.

L1 and R1

L5 and R5

L3 and R3

L2 and L4

R2 and R4

34 Fit a new chain tensioner plunger assembly to the housing in the cylinder head with the piston uppermost. Before fitting the new plunger assembly, take note of the position of the piston (see illustration). The assembly is normally supplied with the piston protruding slightly from the cylinder, or slightly

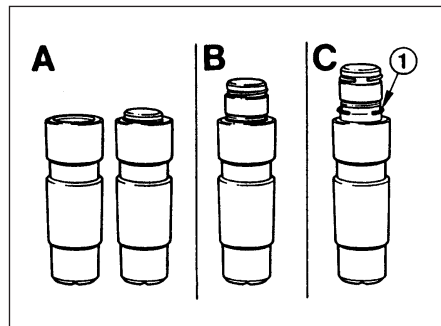

18.34 Timing chain tensioner plunger assembly

A Piston retracted - plunger assembly useable

B Piston partially unlatched - discard plunger assembly

C Latching ring (1) visible - discard plunger assembly

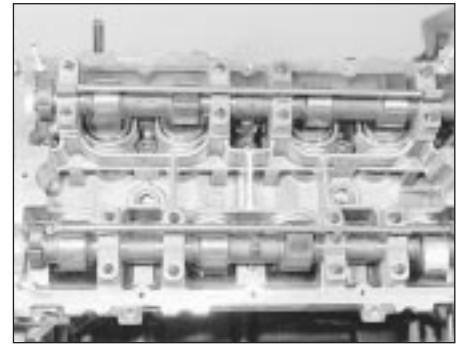

18.30b Camshaft oil spray bars correctly fitted

below the top surface of the cylinder (A). If the new assembly is supplied with the piston partially unlatched (B), or fully unlatched with the latching ring visible (C), it must not be used.



Warning: Take care when installing the plunger assembly, as there is a risk of injury if the piston flies out.

35 Locate the chain tensioner arm in position, then insert the pivot pin, and secure it with the circlip. Take care not to drop the circlip into the timing case.

36 Release the cable-tie securing the timing chain, and lay the chain over the exhaust camshaft sprocket, aligning the marks made previously on the chain and sprocket, so that the timing chain is taught on the exhaust side of the engine.

37 Fit the sprocket to the exhaust camshaft, with the camshaft in the TDC position (ie with the exhaust camshaft sprocket timing mark in line with the top edge of the cylinder head, pointing to the exhaust side of the engine, see paragraph 4). If necessary, use a pair of pliers on one of the unmachined sections of the camshaft to turn the camshaft to the TDC position. Take care not to damage the machined surfaces of the camshaft.

38 With the sprocket fitted, fit the spacer to the end of the camshaft, and tighten the securing bolt finger-tight (see illustration).

39 Lay the timing chain over the inlet



18.38 Spacer and sprocket securing bolt fitted to end of camshaft, with camshaft in TDC position (timing marks arrowed)

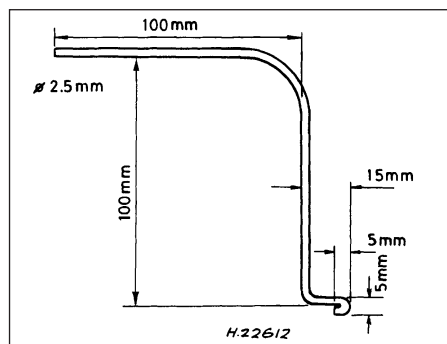

18.45 Fabricated tool used to unlatch tensioner plunger piston

camshaft sprocket, aligning the marks made previously on the chain and the sprocket.

40 Fit the sprocket to the inlet camshaft, with the camshaft in the TDC position (ie with the inlet camshaft sprocket timing mark in line with the top edge of the cylinder head, pointing to the inlet side of the engine see paragraph 4). Again, turn the camshaft if necessary to enable the sprocket to be fitted.

41 With the sprocket fitted, fit the distributor rotor shaft to the end of the camshaft, and tighten the securing bolt finger-tight. Note that it is acceptable for the timing chain to sag slightly between the two pulleys.

42 Fit a new upper timing chain guide to the plate at the front of the cylinder head.

43 Turn the crankshaft clockwise until the inlet camshaft begins to turn.

44 If the chain tensioner plunger piston protrudes from the cylinder, unlatch the piston by pressing the chain tensioner arm down by hand.

45 If the plunger piston is below the top surface of the cylinder, a tool must be fabricated to unlatch the piston (see illustration). It is suggested that 2.5 mm diameter welding rod is used to manufacture the tool. Use the tool to release the piston as follows.

46 Carefully lift the chain tensioner arm with a screwdriver, and insert the tool between the tensioner arm and the piston. Remove the screwdriver, and release the piston by pressing the tensioner arm down by hand. Carefully withdraw the tool once the piston has been released.

47 Tighten the camshaft sprocket securing bolts to the specified torque, holding the sprockets stationary as during removal.

48 Turn the crankshaft clockwise through two complete revolutions, and check that the timing marks on the camshaft sprockets are still aligned with the top face of the cylinder head as described in paragraph 4.

49 Turn the crankshaft clockwise through another complete revolution, and check that the timing marks on the camshaft sprockets are facing each other, directly in line with the top face of the cylinder head.

50 If the timing marks do not align as described, the timing chain has been incorrectly fitted (probably one chain link away

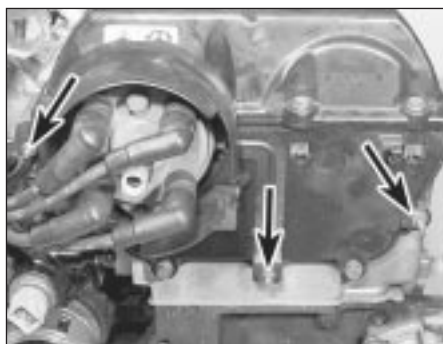

18.53 Upper timing chain cover securing stud locations (arrowed)

from the correct position on one of the camshaft sprockets), and the chain should be removed from the sprockets and fitted in the correct position.

51 Inspect the oil seal in the upper timing chain cover. If the oil seal is in good condition, the cover can be refitted as follows, but if the seal is damaged, or has been leaking, a new seal should be fitted to the cover. If necessary, carefully prise the old oil seal from the cover using a screwdriver, and drive in the new seal using a suitable metal tube. Make sure that the seal lip faces into the engine. Take care not to damage the timing chain cover.

52 Fit the upper timing chain cover using a new rubber gasket. Great care must be taken to avoid damage to the oil seal when passing the seal over the end of the inlet camshaft. Careful manipulation will be required (possibly using a thin feeler blade) to avoid damage to the oil seal sealing lip. Note that the oil seal should be fitted dry.

53 Refit the timing chain cover securing bolts and studs in their original locations and tighten them to the specified torque (see illustration).

54 Remove the reinforcing sleeves from the camshaft cover, and renew the rubber sealing rings. Note that the four short reinforcing sleeves fit at the front of the cover (see illustration).

55 Refit the camshaft cover using a new gasket, and tighten the securing bolts and studs to the specified torque.

19 Cylinder head - dismantling and reassembly

Note: A valve spring compressor will be required during this procedure. New valve stem oil seals should be used on reassembly.

Dismantle the cylinder head as described in paragraphs 2 to 4, Section 12, Part A of this Chapter and reassemble the head as described in paragraphs 4 to 6, Section 42, Part A of this Chapter, noting the following points:

- Ignore the references to the special tool.
- Double valve springs are used on all the valves (see illustration).
- Refer to the following Section if the cylinder head is to be inspected and renovated.



18.54 Fitting a camshaft cover reinforcing sleeve and sealing ring

20 Cylinder head - inspection and renovation

Refer to Part A, Section 34 of this Chapter, noting the following points.

- Valve and valve seat cutting and regrinding can be carried out using conventional tools.
- The cylinder head cannot be resurfaced, and if the surface distortion exceeds the specified limits, the cylinder head must be renewed.

21 Camshafts and cam followers - removal, inspection and refitting

Note: Once the timing chain has been removed from the camshaft sprockets, do not turn the crankshaft until the timing chain has been correctly refitted - this is to prevent contact between the valves and pistons. A new timing chain tensioner plunger assembly, a new upper timing chain cover gasket, and a new camshaft cover and reinforcing sleeve sealing rings must be used on refitting.

1 If the engine is in the vehicle, carry out the following operations.

- Disconnect the battery negative lead.
- On carburettor models, remove the air cleaner.
- On fuel-injection models, remove the air inlet hose, plenum chamber, and air cleaner lid as an assembly.



19.1 Withdrawing the double valve springs from the cylinder head

- d) Disconnect the breather hose from the camshaft cover.
- e) Remove the distributor cap and HT leads, and the rotor arm and housing. If necessary, mark the HT leads to aid refitting.

2 Proceed as described in paragraphs 2 to 15 inclusive of Section 18.

3 Examine the surfaces of the camshaft journals and lobes and the contact surfaces of the cam followers for wear. If wear is excessive, considerable noise would have been noticed from the top of the engine when running, and new camshafts and followers must be fitted. It is unlikely that this level of wear will occur unless a considerable mileage has been covered. Note that the cam followers cannot be dismantled for renewal of individual components.

4 Check the camshaft bearing surfaces in the cylinder head and the bearing caps for wear. If excessive wear is evident, the only course of action available is to renew the cylinder head complete with bearing caps.

5 Check the cam follower bores in the cylinder head for wear. If excessive wear is evident, the cylinder head must be renewed.

6 Check the cam follower oil grooves and the oil ports in the cylinder head for obstructions.

7 Refit the cam followers and the camshafts as described in paragraphs 27 to 55 of Section 18.

8 If the engine is in the vehicle, reverse the operations given in paragraph 1.

22 Flywheel/driveplate - removal inspection and refitting

Refer to Part A, Section 15 of this Chapter, noting the following points.

- a) If the engine is in the car, refer to Chapter 6 when removing and refitting the clutch, where applicable.
- b) The flywheel/driveplate securing bolts must be renewed on refitting; the new bolts are supplied ready-coated with thread-locking compound (see illustration).
- c) Check on the availability of new parts before contemplating renewal of the ring gear.



22.1 Improvised tool used to hold flywheel when tightening securing bolts

23 Crankshaft front oil seal - renewal

Note: A suitable puller will be required to remove the crankshaft pulley. A new crankshaft pulley bolt and a new lower timing chain cover gasket must be used on refitting.

1 The crankshaft front oil seal is located in the lower timing chain cover.

2 If the engine is in the car, carry out the following operations.

- a) Disconnect the battery negative lead.
- b) To improve access, remove the radiator. It will be difficult to remove the crankshaft pulley with the radiator in place.
- c) On fuel-injection models, remove the air inlet hose, plenum chamber, and air cleaner lid as an assembly.

3 Proceed as described in paragraphs 3 to 8 of Section 15.

4 With the lower timing chain cover removed, prise the old oil seal from the cover using a screwdriver, and drive in the new seal using a suitable metal tube. Make sure that the seal lip faces into the engine. Take care not to damage the timing chain cover. Note that the seal should be fitted dry.

5 Refit the lower timing chain cover as described in paragraphs 32 to 40 of Section 15.

6 If the engine is in the vehicle, reverse the operations given in paragraph 2.

24 Crankshaft rear oil seal - renewal

Note: New flywheel/driveplate bolts must be used on refitting.

1 Remove the flywheel/driveplate and the engine adapter plate.

2 Extract the seal using an oil seal removal tool if available. It may also be possible to remove the oil seal by drilling the outer face and using self-tapping screws and a pair of grips.

3 Clean the oil seal housing, then carefully wind a thin layer of tape around the edge of the crankshaft to protect the oil seal lip as the seal is installed.

4 Install a new oil seal. Make sure that the seal lip faces into the engine (see illustration).

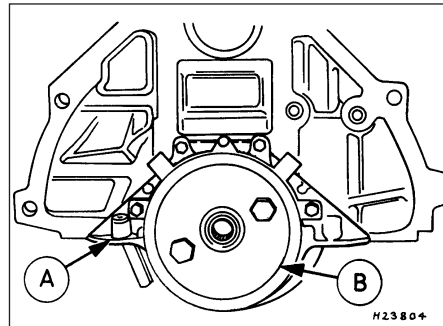

24.4 Tool used to fit the oil seal

- A Rear oil seal housing
B Special tool

HAYNES HiNT A tool can be improvised using a metal tube, a metal disc or flat bar, and two flywheel bolts. Draw the seal into position using the two flywheel bolts.

5 With the oil seal installed, carefully pull the tape from the edge of the crankshaft.

6 Refit the engine adapter plate and the flywheel/driveplate.

25 Sump - removal and refitting

Note: A new sump gasket will be required on refitting, and suitable sealing compound will be required to coat the sump and cylinder block mating faces. Shims may be required when mating the gearbox/transmission.

1 Sump removal and refitting is far easier if the engine is removed from the vehicle, however if the engine is in the vehicle, proceed as follows. If the engine has been removed from the vehicle, proceed to paragraph 9.

2 Remove the clutch or automatic transmission, as applicable.

3 Remove the flywheel/driveplate and the engine adapter plate.

4 Drain the engine oil into a suitable container.

5 Ensure that the steering wheel is positioned in the straight-ahead position then, using a dab of paint or a marker pen, make alignment marks between the intermediate shaft lower clamp and steering gear pinion. Slacken and remove the lower clamp bolt then disconnect the intermediate shaft from the steering gear.

6 Attach a suitable hoist to the engine lifting brackets located at the front and rear of the cylinder head, and carefully take the weight of the engine.

7 Detach the brake lines from the front suspension crossmember.

8 Support the crossmember with a jack, then loosen the bolts securing the crossmember to the underbody. Remove the bolts and carefully lower the crossmember sufficiently to allow the sump to be removed.

9 If the engine has been removed, it is preferable to keep it upright until the sump has been removed to prevent sludge from entering the engine internals.

10 Unscrew the sump securing nuts and bolts, and withdraw the sump from the engine. Do not prise between the mating faces of the sump and cylinder block. Discard the old gasket.

HAYNES HiNT If the sump is stuck, gently tap it sideways to free it (the sump will not move far sideways, as it locates on studs in the cylinder block).

11 Thoroughly clean the mating faces of the cylinder block and sump.

12 Commence refitting by locating a new gasket in the grooves in the sump.

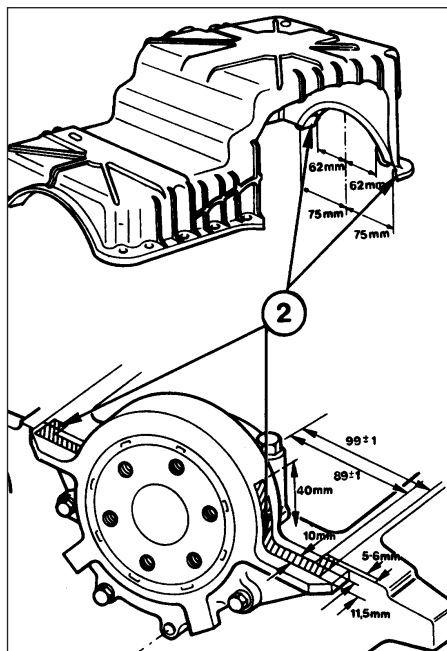

25.13 Apply sealing compound to the sump/cylinder block mating faces at the points indicated (2)

Dimensions are for guidance only

13 Apply a sealing compound to the faces of the cylinder block and sump at the points indicated (see illustration).

14 Apply suitable thread-locking compound to the sump securing studs and bolts, then locate the sump on the cylinder block and fit the securing nuts and bolts, but do not fully tighten them at this stage.

15 Align the sump so that the end faces and the cylinder block are flush. To do this, use a straight-edge. If the sump cannot be positioned so that the faces of the cylinder block and sump are flush, measure the difference in height using a feeler blade as shown (see illustration).

16 Tighten the sump securing nuts and bolts to the specified torque, then repeat the measurement made in paragraph 15. If the end faces of the sump and cylinder block are not flush, suitable shims must be fitted (available from a Ford dealer) between the sump and the gearbox/transmission to eliminate the clearance when mating the engine to the gearbox/transmission. Note that shims should be fitted at both sides of the sump, as required. Select suitable shims from those listed in the following table.

Clearance measured	Shims required
0 to 0.25 mm	No shims required
0.25 to 0.29 mm	0.15 mm (silver)
0.30 to 0.44 mm	0.30 mm (light blue)
0.45 to 0.59 mm	0.45 mm (red)
0.60 to 0.75 mm	0.60 mm (black)

17 If the engine is in the vehicle, reverse the procedure described in paragraphs 3 to 8, noting the following points.

- Ensure that the roadwheels and the steering wheel are in the straight-ahead

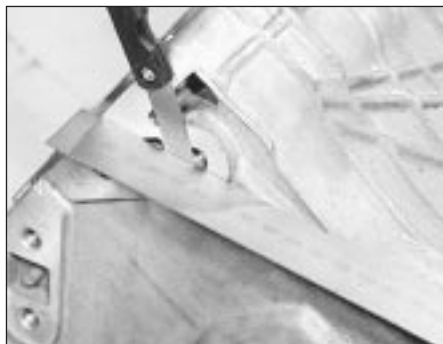

25.15 Measuring the clearance between the cylinder block and sump end faces

position then align the marks made on removal and reconnect the intermediate shaft to the steering gear. Tighten the clamp bolt to the specified torque.

- Fill the engine with the correct grade and quantity of oil.
- Refit the engine adapter plate and the flywheel/driveplate.
- Refit the gearbox or automatic transmission, as applicable, ensuring that the required shims are fitted between the sump and the gearbox/transmission.
- Tighten all fixings to the specified torque where applicable.

26 Oil pump - removal and refitting

Note: A suitable puller will be required to remove the crankshaft pulley. A new crankshaft pulley bolt, a new lower timing chain cover gasket and a new oil pump gasket must be used on refitting.

1 If the engine is in the car, carry out the following operations.

- Disconnect the battery negative lead.
- To improve access, remove the radiator. It will be difficult to remove the crankshaft pulley with the radiator in place.
- On fuel-injection models, remove the air inlet hose, plenum chamber and air cleaner lid as an assembly.

2 Proceed as described in paragraphs 3 to 10 of Section 15.



27.3 Removing the oil pump cover



26.3 Oil pump securing bolts (arrowed)

3 Unscrew the four securing bolts and withdraw the oil pump from the cylinder block (see illustration). Recover the gasket and discard it.

4 If desired, the pump can now be dismantled and inspected.

5 Thoroughly clean the mating faces of the pump and the cylinder block.

6 Prime the pump by injecting clean engine oil into it and turning it by hand.

7 Place a new gasket on the oil pump flange, ensuring that the gasket is correctly located so that the holes align with the oil passages in the pump.

8 Fit the oil pump, and tighten the securing bolts to the specified torque.

9 Proceed as described in paragraphs 28 to 40 of Section 15.

10 If the engine is in the vehicle, reverse the operations described in paragraph 1.

27 Oil pump - dismantling, inspection and reassembly

1 The oil pump can be dismantled for cleaning, but if any of the components are worn, the pump must be renewed as an assembly.

2 To dismantle the pump, proceed as follows.

3 Unscrew the two securing bolts, and remove the pump cover (see illustration).

4 Lift the inner and outer rotors from the pump casing.

5 Unscrew the pressure relief valve plug from



27.5a Unscrew the pressure relief valve plug and washer . . .



27.5b . . . and withdraw the spring and plunger

the pump cover, recover the washer, and withdraw the spring and plunger (see illustrations).

6 Thoroughly clean all components in petrol or paraffin, and wipe dry using a non-fluffy rag.
7 Examine the rotors and the pump casing for signs of excessive wear on the machined surfaces. If wear is evident, the complete pump assembly must be renewed, as spare parts are not available individually.

8 Commence reassembly by lubricating the relief valve plunger. Fit the plunger and the spring, and screw the plug into place, ensuring that the washer is in place under the plug.

9 Lubricate the rotors, and fit them to the pump casing with the punch marks facing the pump cover (see illustration).

10 Refit the pump cover and tighten the securing bolts.

11 Prime the pump before refitting.

28 Oil pump drive chain and sprockets - examination and renovation

1 Examine all the teeth on the sprockets. If the teeth are "hooked" in appearance, renew the sprockets.

2 Examine the chain tensioner for wear and renew it if necessary.

3 Examine the chain for wear. If it has been in operation for a considerable time, or if when held horizontally (rollers vertical) it takes on a deeply bowed appearance, renew it.



27.9 The punch marks (arrowed) on the oil pump rotors must face the pump cover

29 Pistons and connecting rods - removal and refitting

Note: *New connecting rod bolts and a new oil pick-up pipe gasket must be used on refitting.*

1 Remove the sump and the cylinder head.

2 Unscrew the two securing bolts, and remove the oil pick-up pipe (see illustration). Recover the gasket and discard it.

3 Unscrew the four securing nuts and withdraw the oil baffle from the studs on the main bearing caps (see illustration).

4 Removal is as described in Part A, Section 21, paragraphs 2 to 5 of this Chapter, and refitting as described in Part A, Section 37, noting the following additional points:

- a) *Take note of the orientation of the bearing shells during dismantling, and ensure that they are fitted correctly during reassembly.*
- b) *When fitting the pistons, ensure that the arrow on the piston crown and the letter F on the face of the connecting rod are pointing towards the front of the engine.*
- c) *Use new connecting rod bolts on reassembly; before fitting, oil the threads and the contact faces of the bolts. Tighten the bolts to the three stages given in the Specifications.*
- d) *Refit the oil baffle and tighten the securing nuts.*
- e) *Clean the mating faces of the cylinder block and the oil pick-up pipe, and refit the pick-up pipe using a new gasket.*
- f) *Refit the cylinder head and the sump.*



29.2 Removing the oil pick-up pipe

30 Crankshaft and main bearings - removal and refitting

Note: *A new crankshaft rear oil seal and a new rear oil seal housing gasket should be used on reassembly.*

1 With the engine removed from the vehicle, remove the timing chain and crankshaft sprocket, and the flywheel/driveplate.

2 Remove the pistons and connecting rods. If no work is to be done on the pistons and connecting rods, there is no need to push the pistons out of the cylinder bores.

3 Unbolt the crankshaft rear oil seal housing and remove it from the rear of the cylinder block. Recover the gasket and discard it.

4 Unscrew the two securing bolts and remove the sump mounting plate from the front of the cylinder block (see illustration).

5 Check the main bearing caps for identification marks, and if necessary use a centre punch to identify them (see illustration).

6 Before removing the crankshaft, check that the endfloat is within the specified limits by inserting a feeler blade between the centre crankshaft web and one of the thrustwashers (the thrustwashers are fitted to the crankcase, not the bearing cap). This will indicate whether or not new thrustwashers are required.

7 Unscrew the bolts and tap off the main bearing caps complete with bearing shells.

8 Lift the crankshaft from the cylinder block, and remove the rear oil seal if it is still in place on the crankshaft.



29.3 Withdrawing the oil baffle

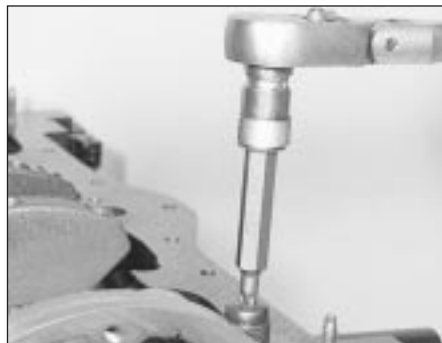

30.4 Unscrewing a sump mounting plate securing bolt



30.5 Main bearing cap identification mark (arrowed)

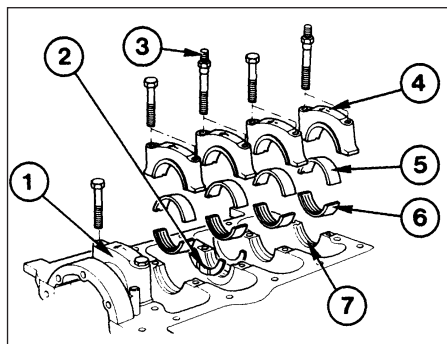

30.11 Crankshaft main bearings and associated components

- 1 Bearing cap
- 2 Thrustwasher
- 3 Stud for oil baffle
- 4 Identification markings
- 5 Bearing shell without oil groove
- 6 Bearing shell with oil groove
- 7 Bearing seat in cylinder block

9 Extract the bearing shells, and recover the thrustwashers, keeping them identified for location.

10 The crankshaft and bearings can be examined and if necessary renovated.

11 Commence refitting as follows (see illustration).

12 Wipe the bearing shell locations in the crankcase, and the crankshaft journals with a soft non-fluffy rag.

13 If the old main bearing shells are to be renewed (not to do so is a false economy, unless they are virtually new) fit the five upper halves of the main bearing shells to their locations in the crankcase.

14 Fit the thrustwashers to the centre main bearing location, using a little grease to retain them if necessary. The oil grooves in the thrustwashers must face outwards (ie facing the crankshaft webs). Note that where standard thrustwashers have been fitted in production, the centre main bearing is unmarked, but if oversize (0.38 mm) thrustwashers have been fitted, the centre main bearing will carry a yellow paint mark.

15 Lubricate the crankshaft journals and the upper and lower main bearing shells with clean engine oil, then carefully lower the crankshaft into the crankcase.

16 Lubricate the crankshaft main bearing journals again, and then fit the main bearing caps in their correct locations, with the arrows on the caps pointing towards the front of the engine.

17 Fit the main bearing cap bolts, noting that the studded bolts secure bearing caps Nos 3 and 5.

18 Lightly tighten all the securing bolts, then progressively tighten all bolts to the specified torque.

19 Check that the crankshaft rotates freely. Some stiffness is to be expected with new

components, but there must be no tight spots or binding.

20 Check that the crankshaft endfloat is within the specified limits by inserting a feeler blade between the centre crankshaft web and the thrustwashers.

21 Refit the sump mounting plate to the front of the cylinder block, and tighten the securing bolts to the specified torque.

22 Carefully wind a thin layer of tape around the rear edge of the crankshaft to protect the oil seal lips as the rear oil seal is installed.

23 Refit the crankshaft rear oil seal housing, using a new gasket, and tighten the securing bolts to the specified torque.

24 Install the new oil seal with reference to Section 24.

25 With the oil seal installed, carefully pull the tape from the edge of the crankshaft.

26 Refit the pistons and connecting rods as described previously in this Chapter.

27 Refit the flywheel/driveplate, and the timing chain and crankshaft sprocket.

31 Crankshaft and bearings - examination and renovation

Proceed as described in Part A, Section 27 of this Chapter, noting that the production bearing undersizes are indicated as follows.

Yellow or red paint marks on crankshaft — standard diameter main bearing journals.

Green line on crankshaft front counterweight — main bearing journals 0.25 mm undersize.

Green spot on counterweight — big-end bearing journals 0.25 mm undersize.

32 Examination and renovation - general information

Refer to Part A, Section 25 of this Chapter, but note that the connecting rod bolts should be renewed on reassembly, and when renewing the cylinder head bolts, the latest type bolts with hexagonal heads should always be used.

33 Engine reassembly - general information

Proceed as described in Part A, Section 35 of this Chapter, noting the following points.

- a) *If the cylinder head has been removed, pay particular attention to the note at the beginning of Section 18.*
- b) *If removed during any dismantling operations, new flywheel driveplate bolts and connecting rod bolts must be used.*
- c) *After reassembling the main engine components, refer to paragraph 3 of Section 14 and refit the ancillary components listed.*

34 Initial start-up after overhaul or major repair

Refer to Part A, Section 51 of this Chapter, but note that when the engine is first started, a metallic tapping noise may be heard. This is due to the timing chain tensioner plunger assembly taking time to pressurize with oil, resulting in a temporarily slack chain. The noise should stop after a short time, once oil pressure has built up.

35 Compression test - description and interpretation

1 When engine performance is down, or if misfiring occurs which cannot be attributed to the ignition or fuel system, a compression test can provide diagnostic clues. If the test is performed regularly it can give warning of trouble before any other symptoms become apparent.

2 The engine must be at operating temperature, the battery must be fully charged and the spark plugs must be removed. The services of an assistant will also be required.

3 Disable the ignition system by dismantling the coil LT feed. Fit the compression tester to No 1 spark plug hole. (The type of tester which screws into the spark plug hole is to be preferred.)

4 Have the assistant hold the throttle wide open and crank the engine on the starter. Record the highest reading obtained on the compression tester.

5 Repeat the test on the remaining cylinders, recording the pressure developed in each.

6 Desired pressures are given in the Specifications. If the pressure in any cylinder is low, introduce a teaspoonful of clean engine oil into the spark plug hole and repeat the test.

7 If the addition of oil temporarily improves the compression pressure, this indicates that bore or piston wear was responsible for the pressure loss. No improvement suggests that leaking or burnt valves, or a blown head gasket, may be to blame.

8 A low reading from two adjacent cylinders is almost certainly due to the head gasket between them having blown.

9 On completion of the test, refit the spark plugs and reconnect the coil LT feed.