

Control System

GENERAL

SCHEMATIC DIAGRAM

COMPONENT LOCATION

CONNECTOR CONFIGURATIONS

HARNESS LAYOUTS

General

INTRODUCTION	GI- 2
SYMBOLS	GI- 6
TROUBLESHOOTING INSTRUCTIONS	GI- 9

INTRODUCTION

KFDE6BC0

This Manual consists of five major diagnostic sections for electrical troubleshooting.

- Schematic diagrams
- Component location indexes
- Component locations
- Connector configurations
- Harness layouts

SCHEMATIC DIAGRAMS

The starting point of each system section is the schematic diagram. These diagrams show how all the components work together, such as electrical current paths from power source to ground(via electrical load), switch connections at each position, and other related circuit functions.

It is important to fully understand how a circuit works prior to troubleshooting and diagnosis.

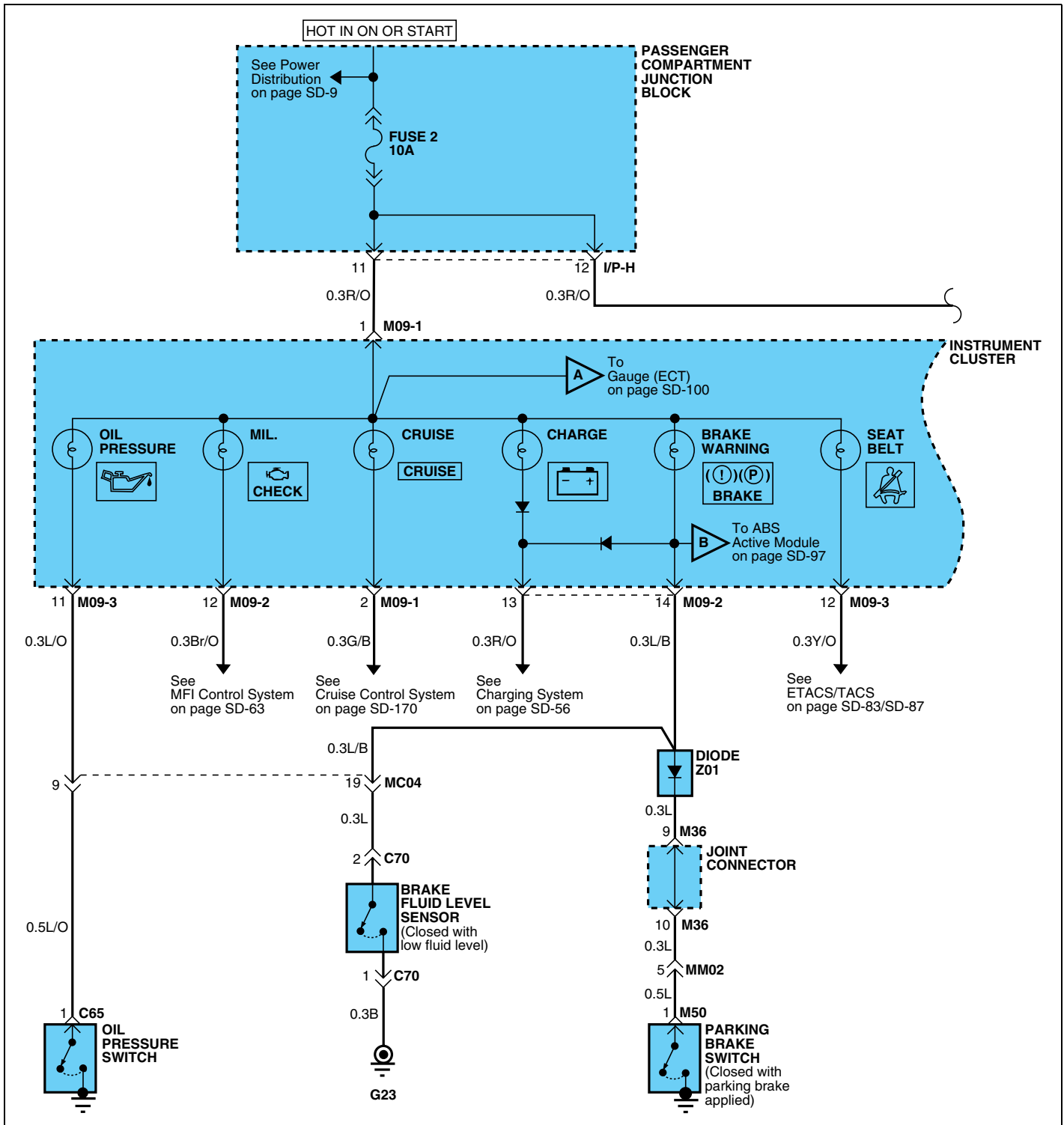

COMPONENT LOCATION INDEXES

When you want to locate the schematic components on the vehicle, use the Component Location Index which follows each schematic. A Component Location Index lists major

components, connectors, grounds, diodes, and their physical location and page reference. Almost all components, connectors or grounds, and diodes shown on a schematic can be pinpointed visually by using the Component Location Illustrations.

Components		Location Reference - Page
I12	Digital clock	CL-15
I16-1	Instrument cluster	CL-15
M55	Fuel sender	CL-19
M56	Fuel pump	CL-19
C34	Engine coolant temperature sender	CL-5, CL-8
Connectors		
MI01/MI02/MI03		CL-21
MC02		CL-21
CC02		CL-8
Grounds		
G01		CL-24
G02		CL-24

EGI001B

COMPONENT LOCATIONS

Component Locations make it easy to find the schematic components on the vehicle shown in the Component Location Index.

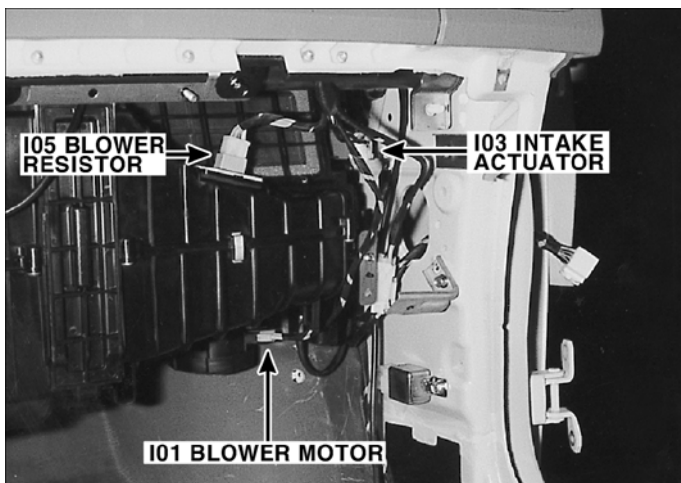

EGI001C

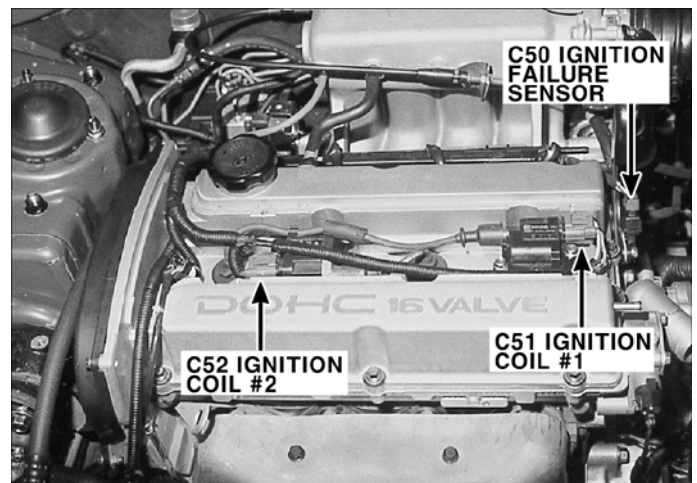

EGI001D

CONNECTOR CONFIGURATIONS

This section shows the cavity or terminal locations in all the multi-pin connectors shown in the schematic diagrams. It will help you to locate check points, together with the wire

colors and terminal numbers in the schematic. The configuration drawings show the connector view as seen from a component after the harness connector has been disconnected. When more than one connector is connected to a component, the connectors are all shown together. Both halves of in-line connectors are shown together.

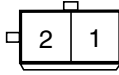
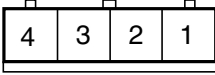
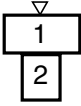
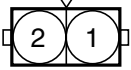
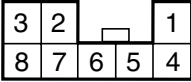
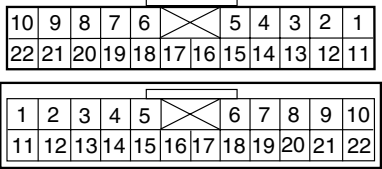
<p>E37-2</p> 	<p>E38</p> 	<p>E39</p> 	<p>E42</p> 
<p>E46</p> 	<p>E47</p> 	<p>EM01</p> 	

EGI001E

CONNECTOR VIEW AND NUMBERING ORDER

1. CONNECTOR VIEW

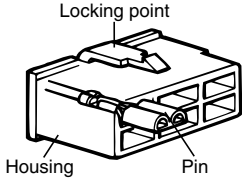
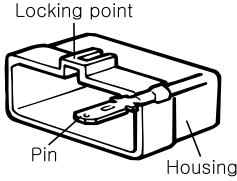
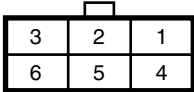
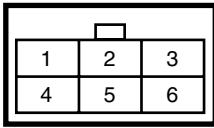
	Female	Male	Remarks
<p>Actual Illustration</p>			<p>It is not the shape of the connector housing, but the connector pin that distinguishes between male or female connectors. When numbering female and male connectors, refer to the numbering order in the following table. Some connectors may not follow this method of numbering order. For individual detailed numbering, refer to the CONNECTOR CONFIGURATIONS.</p>
<p>Illustration in the Shop manual</p>			

EGI001F

NOTE

UNLESS OTHERWISE STATED, ALL CONNECTOR VIEWS ARE FROM THE TERMINAL SIDE OF THE CONNECTOR.

2. NUMBERING ORDER

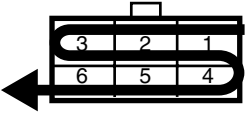
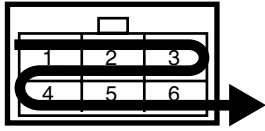
	Numbering order	Remarks
Female Connector		Numbered in order from upper right to lower left
Male Connector		Numbered in order from upper left to lower right

EGI001G

HARNESS LAYOUTS

Harness layouts show the routing of the major wiring harnesses, the in-line connectors and the splices between the major harnesses. These layouts will make electrical troubleshooting easier.

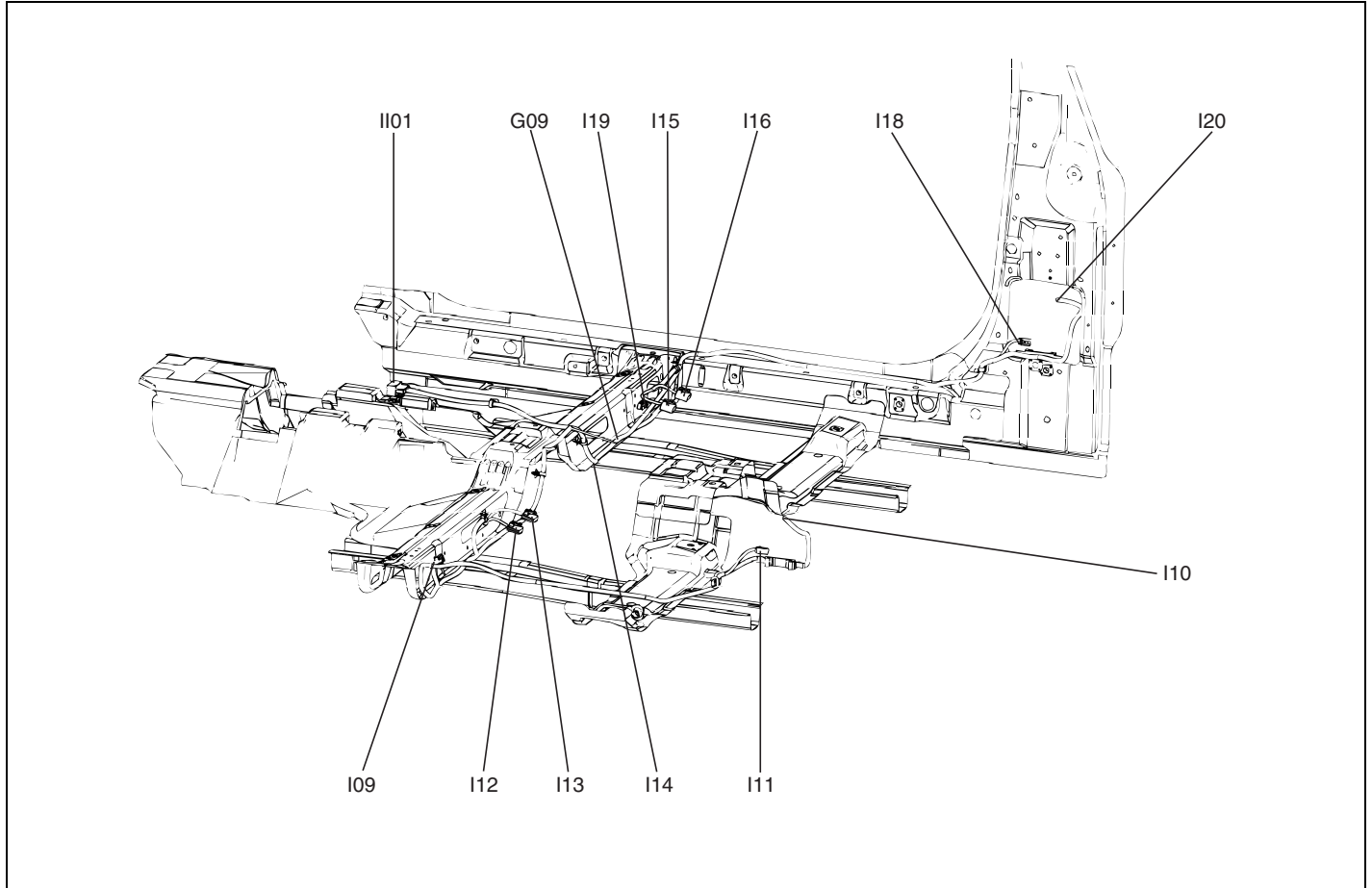

EGI001H

SYMBOLS

KC68AF55

The symbols and abbreviations explained in this section are used throughout the manual.

SYMBOLS IN SCHEMATIC

Components



A solid line means the entire component is shown.



A broken line indicates only part of the component is shown.



STOP LAMP SWITCH
Closed with pedal depressed

The name of the component appears next to its upper right corner.

Notes about component function follow its name.

Connectors

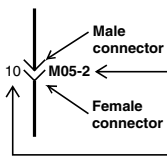

Male connector

Connector number

Female connector

Connector cavity number

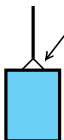

This means the connector connects directly to the component.

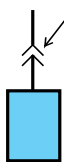

This indicates the connector connects to a lead (pigtail), wired directly to the component.

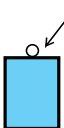

This indicates a screw terminal on the component.

Diode



This diode allows current to flow only in the direction of the arrow.

Fuse and Fusible link

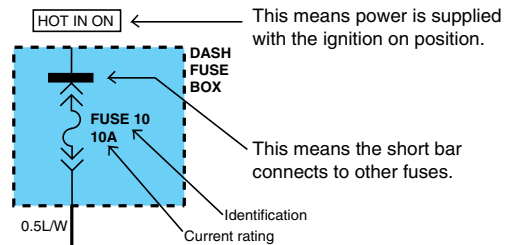

This means power is supplied with the ignition on position.

This means the short bar connects to other fuses.

Identification

Current rating

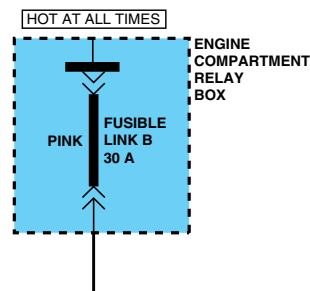

Circuit Breaker



Basically a reusable fuse, a circuit breaker will heat and open if too much current flows through it. Some units automatically reset when cool, others must be manually reset.

Wires

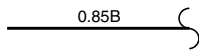

A wavy line means the wire is broken but is to be continued.

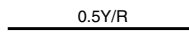

Wire insulation is yellow with a red strip.

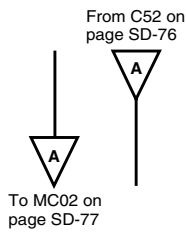

Current path is continued on the same page or another page. The arrow shows the direction of current flow. You should look for the "A" in the marked position.

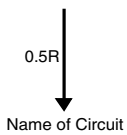

A wire connects to another circuit. The wire is shown again on that circuit which the arrow is pointing.

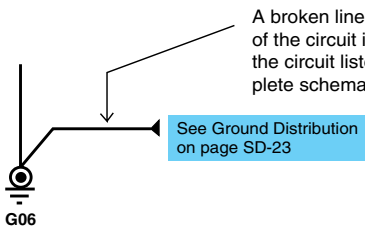

A broken line means only some of the circuit is shown: refer to the circuit listed for the complete schematic.

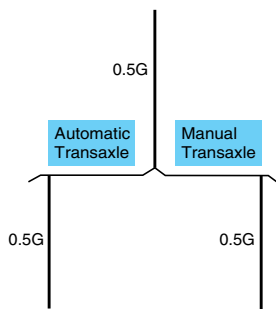

Wire choices for options or different models are labeled and shown with a "choice" bracket like this.

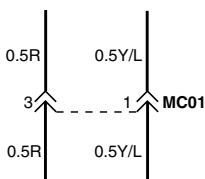

This dashed line means the R(red) and Y/L(yellow/blue) wires are both in connector MC01.

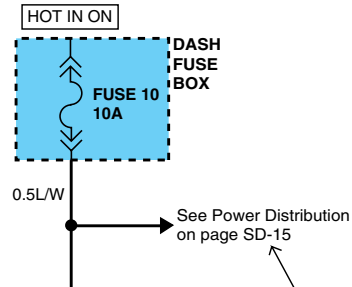

Where separate wires join, only the splice is shown: for details on the additional wiring, refer to the circuit listed.

Splices

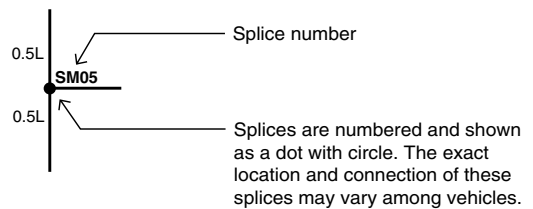

Ground - "G"

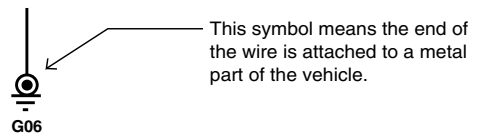

This ground symbol (dot and 3 lines overlapping the component) means the housing of the component is attached to a metal part of the vehicle.

Shield Wire

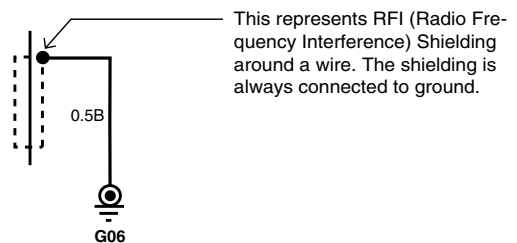

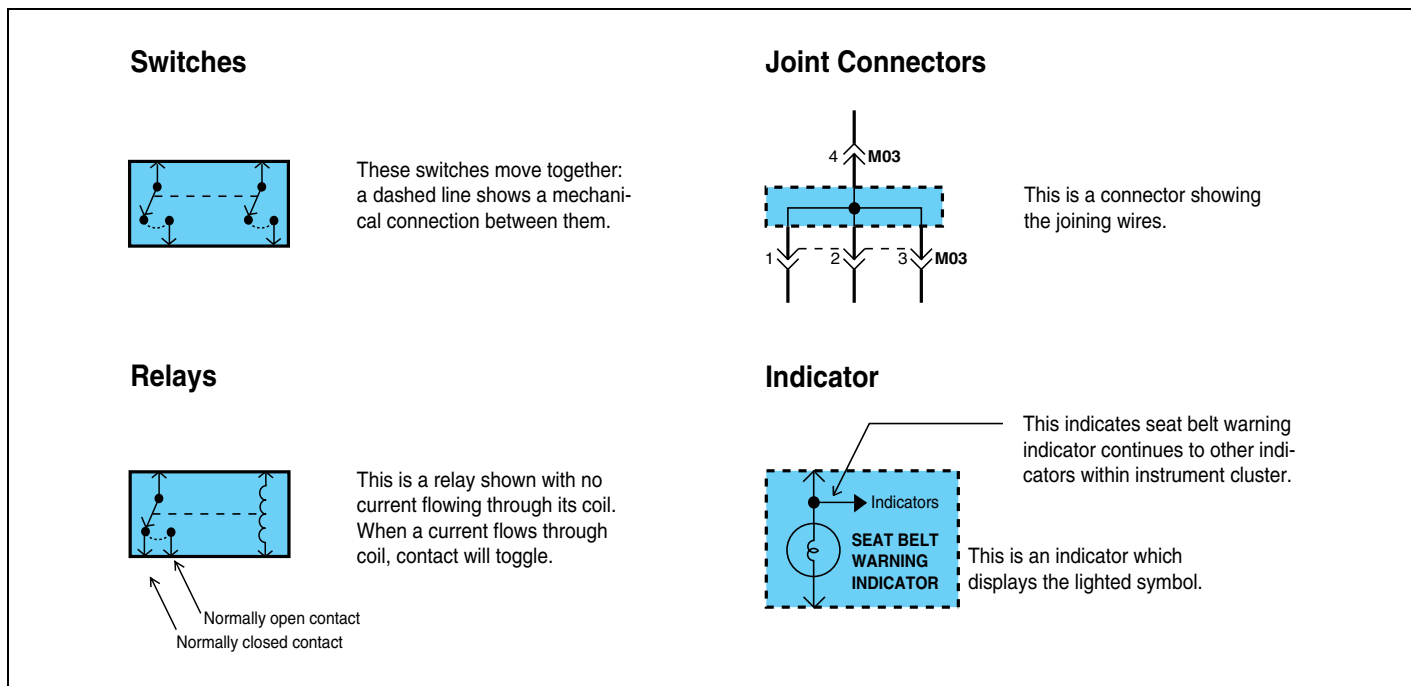

EGI002C

WIRE COLOR ABBREVIATIONS

The following abbreviations are used to identify wire colors in the circuit schematics.

Symbol	Color of wire	Symbol	Color of wire
B	Black	O	Orange
Br	Brown	P	Pink
G	Green	R	Red
Gr	Gray	W	White
L	Blue	Y	Yellow
Lg	Light green		

HARNESS CLASSIFICATION

Electrical wiring connectors are classified according to the wiring parts in the Harness Layouts.

Harness name	Location	Symbol
Engine harness	Engine compartment	E
Main, Floor, Roof, Sunroof, Seat warmer ext. harness	Passenger compartment, Floor, Roof	M
Control, Injector harness	Engine compartment	C
Tail gate harness	Tail gate	R
Air bag harness	Under crash pad and Floor	I
Door harness	Door	D

CONNECTOR IDENTIFICATION

A connector identification symbol consists of a wiring harness location classification symbol corresponding to a wiring harness location and number corresponding to the

connector. These connector locations can be found in the HARNESS LAYOUTS.

For example :

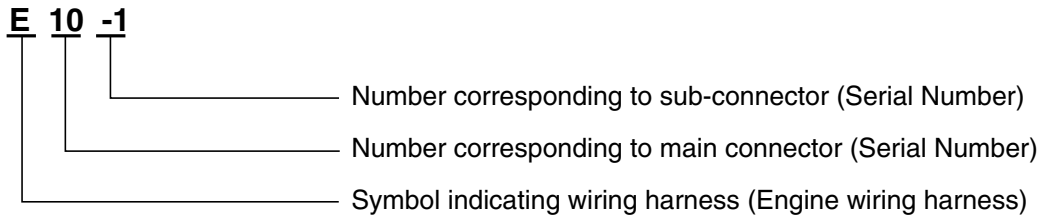

EGI002D

NOTE

Connectors which connect each wiring harness are represented by the following symbols.

For example :

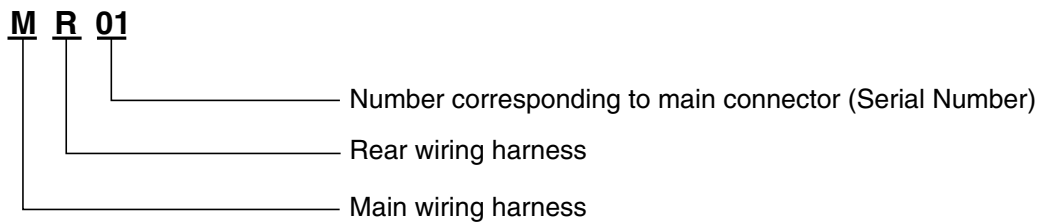

EGI002E

JUNCTION BLOCK IDENTIFICATION

A junction block identification symbol consists of a wiring harness location classification symbol corresponding to a

wiring harness location and number corresponding to the connector in the junction block.

For example :

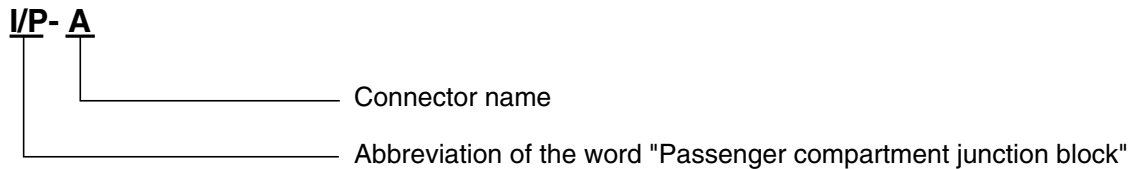

EGI002F

For example :

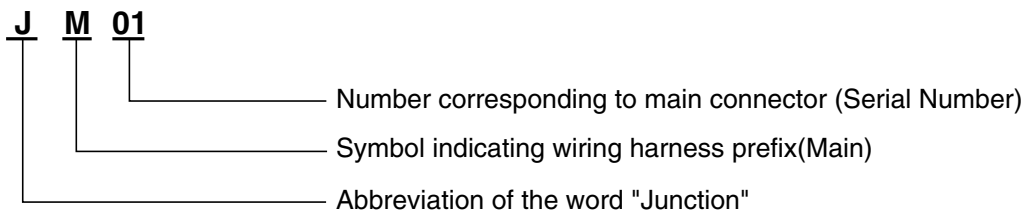

EGI002G

TROUBLESHOOTING INSTRUCTIONS

K9A93EB1

TROUBLESHOOTING PROCEDURES

The following five-steps troubleshooting procedure is recommended.

1. Verify the customer's complaints

Turn on all the components in the problem circuit to check the accuracy of the customer's complaints. Note the symptoms. Do not begin disassembly or testing until you have narrowed down the probable causes.

2. **Read and analyze the schematic diagram**

Locate the schematic for the problem circuit. Determine how the circuit is supposed to work by tracing the current paths from the power source through the system components to ground. If you do not understand how the circuit should work, read the circuit operation text. Also check other circuits that share with the problem circuit. The name of circuits that share the same fuse, ground, or switch, for example, are referred to on each diagram. Try to operate any shared circuits you did not check in step 1. If the shared circuit works, the shared wiring is okay, and the cause must be within the wiring used only by the problem circuit. If several circuits fail at the same time, the fuse or ground is a likely cause.

3. **Inspect the circuit/ component with the problem isolated**

Make a circuit test to check the diagnosis you made in step 2. Remember that a logical, simple procedure is the key to efficient troubleshooting. Narrow down the probable causes using the troubleshooting hints and system diagnosis charts. Test for the most likely cause of failure first. Try to make tests at points that are easily accessible.

4. **Repair the problem**

Once the problem is found, make the necessary repairs.

5. **Make sure the circuit works**

Repeat the system check to be sure you have repaired the problem. If the problem was a blown fuse, be sure to test all of the circuits on that fuse.

TROUBLESHOOTING EQUIPMENT

VOLTMETER AND TEST LAMP

Use a test lamp or a voltmeter on circuits without solid-state units and use a test lamp to check for voltage. A test lamp is made up of a 12-volt light bulb with a pair of leads attached. After grounding one lead, touch the other lead to various points along the circuit where voltage should be present. When the bulb goes on, there is voltage at the point being tested.>

CAUTION

A number of circuits include solid-state modules, such as the Engine Control Module(ECM), used with computer command control injection. Voltage in these circuits should be tested only with a 10-megaohm or higher impedance digital volt-met er . Never use a test lamp on circuits that contain solid state modules. Damage to the modules may result.

A voltmeter can be used in place of a test lamp. While a test lamp shows whether the voltage is present or not, a voltmeter indicates how much voltage is present.

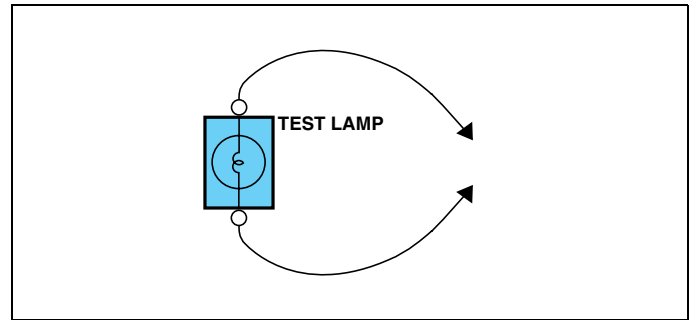

EGI003A

SELF-POWERED TEST LAMP AND OHMMETER

Use a self-powered test lamp or an ohmmeter to check for continuity. The ohmmeter shows how much resistance there is between two points along a circuit. Low resistance means good continuity.

CAUTION

Never use a self-powered test lamp on circuits that contain solid state modules. Damage to these modules may result.

An ohmmeter can be used in place of a self-powered test lamp. The ohmmeter shows how much resistance there is between two points along a circuit. Low resistance means good continuity.

Circuits which include any solid-state devices should be tested only with a 10-megaohm or higher impedance digital multimeter. When measuring resistance with a digital multimeter, the battery negative terminal should be disconnected. Otherwise, there may be incorrect readings. Diodes and solid-state devices in a circuit can make an ohmmeter give a false reading. To find out if a component is affecting a measurement, take one reading, reverse the leads and take a second reading. If different the solid-state device is affecting the measurement.

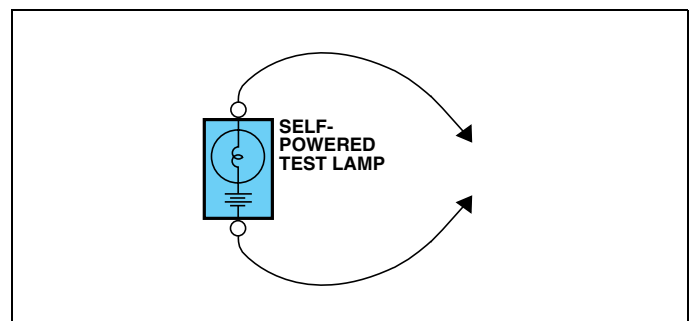

EGI003B

JUMPER WIRE WITH FUSE

Use a jumper wire with a fuse to by-pass an open circuit.

A jumper wire is made up of an in-line fuse holder connected to a set of test leads. This tool is available with small clamp connectors providing adaption to most connectors without damage.

CAUTION

Do not use a fuse with a higher rating than the specified fuse that protects the circuit being tested. Do not use this tool in any situation to substitute an input or output at the solid-state control module, such as ECM, TCM, etc.

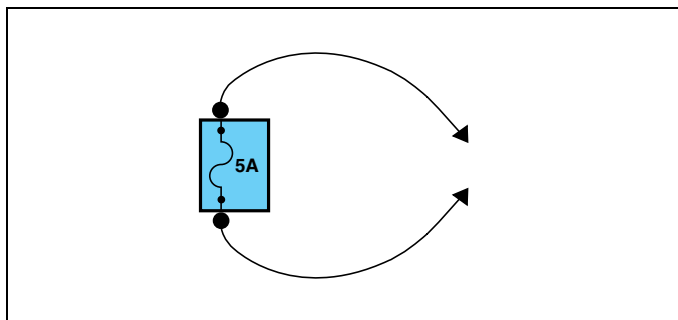

EGI003C

SHORT FINDER

A short finder is available to locate a short to ground. The short finder creates a pulsing magnetic field in the shorted circuit and shows you the location of the short through body trim or sheet metal.

TROUBLESHOOTING TEST

1. TESTING FOR VOLTAGE

This test measures voltage in a circuit. When testing for voltage at a connector, you do not have to separate the two halves of the connector. Instead, probe the connector from the back(backprobe). Always check both sides of the connector because dirt and corrosion between its contact surfaces can cause electrical problems.

- A. Connect one lead of a test lamp or voltmeter to a ground. If you are using a voltmeter, be sure it is the voltmeter's negative test lead you have connected to ground.
- B. Connect the other lead of the test lamp or voltmeter to a selected test point(connector or terminal).
- C. If the test lamp glows, there is voltage present. If you are using a voltmeter, note the voltage reading. A loss of more than 1 volt from specification indicates a problem.

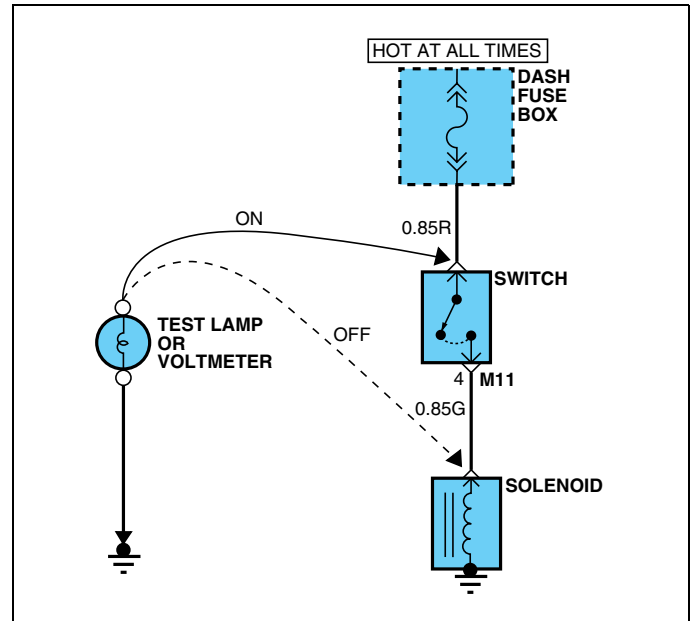

EGI003D

2. TESTING FOR CONTINUITY

- A. Disconnect the battery negative terminal.
- B. Connect one lead of a self-powered test lamp or ohmmeter to one end of the part of the circuit you wish to test. If you are using an ohmmeter, hold the leads together and adjust the ohmmeter to read zero ohms.
- C. Connect the other lead to the other end.
- D. If the self-power test lamp glows, there is continuity. If you are using an ohmmeter, low or zero resistance means good continuity.

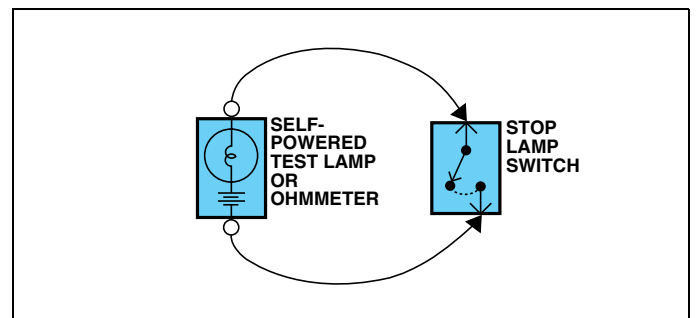

EGI003E

3. TESTING FOR SHORT TO GROUND

- A. Disconnect the battery negative terminal.
- B. Connect one lead of a self-powered test lamp or an ohmmeter to the fuse terminal on the load side.
- C. Connect the other lead to a ground.
- D. Beginning near the fuse block move the harness from side to side. Continue this procedure(about six inches apart) while watching the self-powered test lamp or ohmmeter.
- E. When the self-powered test lamp glows, or ohmmeter registers, there is a short to a ground in the wiring near that point.

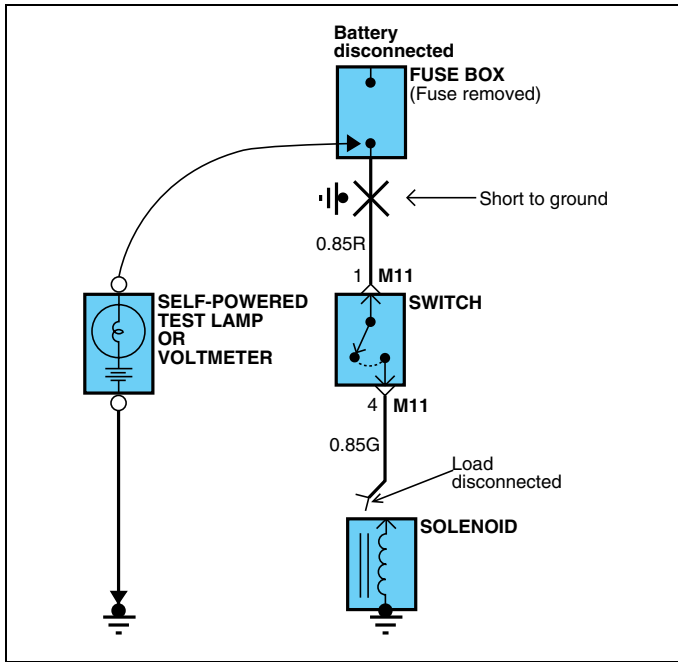

EGI003F

4. TESTING FOR A SHORT WITH A SHORT FINDER

- A. Remove the blown fuse. Leave the battery connected.
- B. Connect the short finder across the fuse terminals.
- C. Close all switches in series in the circuit that is being tested.
- D. Turn on the short circuit locator. It sends pulses of current to the short. This creates a pulsing magnetic field around the wiring between the fuse box and the short.
- E. Beginning at the fuse box, slowly move the short finder along the circuit wiring. The meter will show current pulses through sheet metal and body trim. As long as the meter is between the fuse and the short, the needle will move with each current pulse. Once the meter is moved past the point of the short, the needle will stop moving. Check around this area to locate the cause of the short circuit.

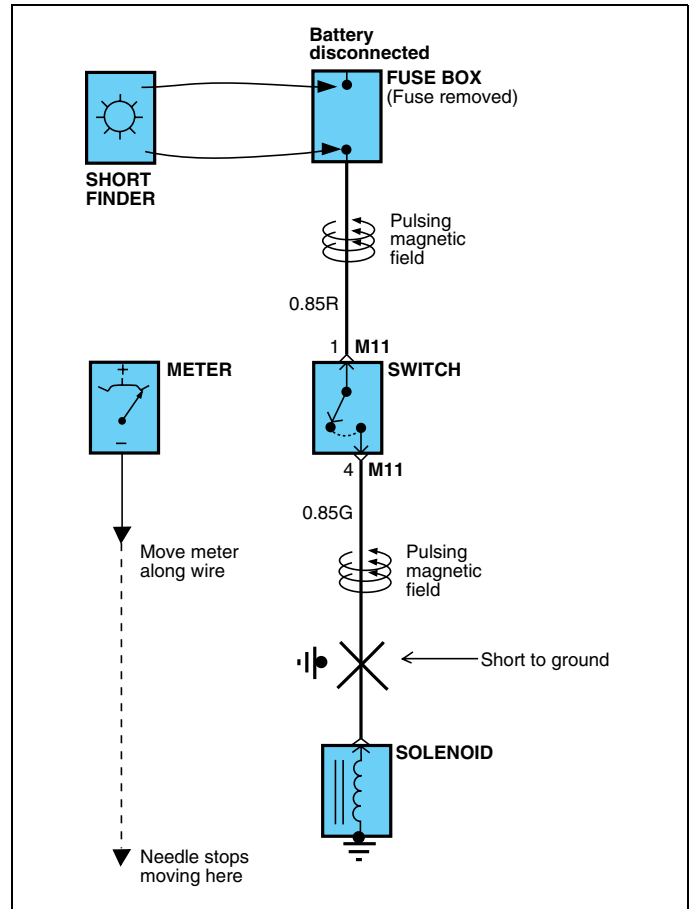

EGI003G

Schematic Diagram

FUSE AND RELAY INFORMATION	SD- 2
POWER DISTRIBUTION	SD- 6
FUSE BOX DETAILS	SD- 8
GROUND DISTRIBUTION	SD-14
VEHICLE SPEED SENSOR & TACHOGRAPH	SD-18
STARTING & CHARGING SYSTEM	SD-20
PREHEATING SYSTEM	SD-22
OVERHEAT WARNING SYSTEM	SD-24
PREHATER CONTROLS	SD-26
EXHAUST BRAKE SYSTEM	SD-28
ACCELERATOR INTERLOCK SYSTEM	SD-30
ANTI-LOCK BRAKE SYSTEM (ABS)	SD-32
CLOCK & CIGARETTE LIGHTER	SD-36
ETACS (ELECTRONIC TIME AND ALARM CONTROL SYSTEM)	SD-40
FRONT WIPER AND WASHER	SD-42
REAR WIPER AND WASHER	SD-44
SAFETY DOOR SYSTEM	SD-46
INDICATORS	SD-48
GAUGES	SD-52
HIGH SPEED WARNING SYSTEM	SD-54
POWER DOOR SYSTEM	SD-56
OUTSIDE MIRROR DEFOGGER	SD-58

AUDIO & HORN SYSTEM	SD-60
HEAD LAMPS	SD-64
TURN, HAZARD LAMPS & BACK-UP LAMPS	SD-66
FRONT FOG LAMPS	SD-70
REAR FOG LAMPS	SD-72
ROOM LAMPS	SD-74
TAIL, PARKING & LICENSE LAMPS	SD-76
READING LAMPS	SD-78
STOP LAMPS	SD-80
COURTESY LAMPS	SD-82
ILLUMINATIONS	SD-84
HEATER & VENTILATOR CONTROL SYSTEM	SD-88
A/C CONTROLS	SD-92

FUSE AND RELAY INFORMATION E21BF1AC

FUSE BOX

LAYOUT

SPARE 5A		SPARE 10A		SPARE 15A		SPARE 15A		SPARE 20A		FUSE PULLER	
1	2	3	4	5	6	7	8	9	10	11	12
5A	10A	10A	10A	10A	10A	15A	10A	10A	10A	10A	10A
13	14	Not used	16	17	18	19	20	21	Not used	23	24
15A	15A		20A	15A	20A	15A	15A	15A		10A	5A
25	26	27	28	29	30	31	32	Not used	34	35	36
10A	15A	15A	10A	15A	15A	10A	15A		10A	15A	10A

CIRCUIT

Fuse No.	Amperages(A)	Circuit protected
1	5A	Head lamps, Reading lamps
2	10A	Instrument cluster, ETACM, High speed warning, Generator
3	10A	Hazard warning
4	10A	Ventilator switch
5	10A	Accelerator interlock, Back-up lamp switch, Overheat warning
6	10A	Rear wiper & washer
7	15A	Door open switch, Folding door, Swing door
8	10A	Heater, A/con
9	10A	Wiper & Washer
10	5A	DBR, Cold start
11	5A	ABS
12	10A	Preheater
13	15A	Head lamp (High)
14	15A	Head lamp (Low)
15	-	Not used
16	20A	Not used
17	15A	Audio, Clock, Cigarette lighter
18	20A	Condenser relay
19	15A	Evaporator relay
20	15A	Evaporator relay
21	15A	Evaporator relay
22	-	Not used
23	10A	Room lamp, Tachograph, ETACM
24	5A	Not used
25	10A	Tail lamp
26	15A	Not used
27	15A	ETACM, Audio, Room lamp, Luggage lamp, Instrument cluster
28	10A	Horn, Hazard warning
29	15A	Blower motor relay
30	15A	Rear heater
31	10A	Fog lamp
32	15A	Preheater
33	-	Not used
34	10A	Reading lamp
35	15A	ABS
36	10A	Stop lamp, Accelerator interlock

RELAY BOX

LAYOUT

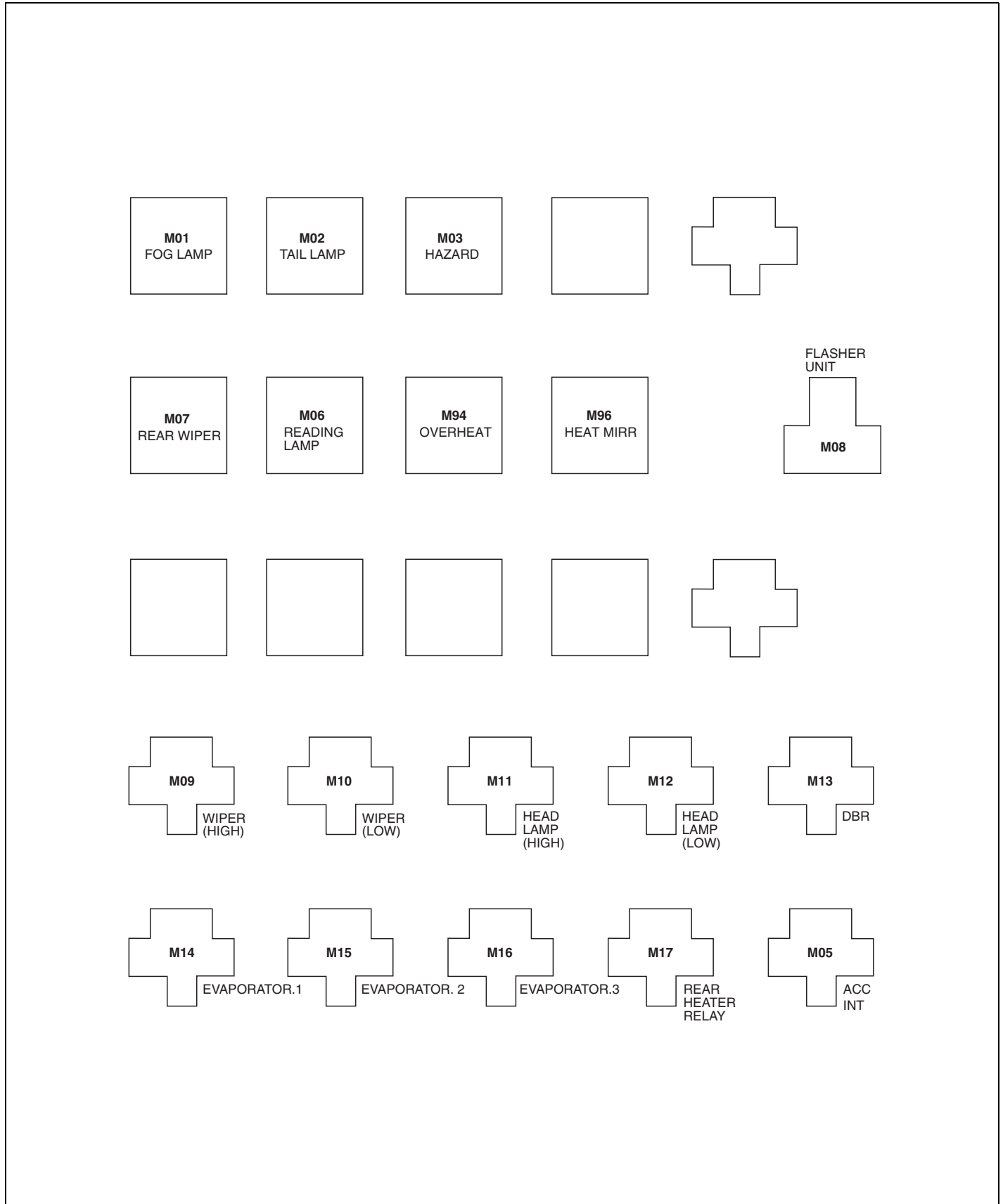

FUSIBLE LINK BOX

LAYOUT

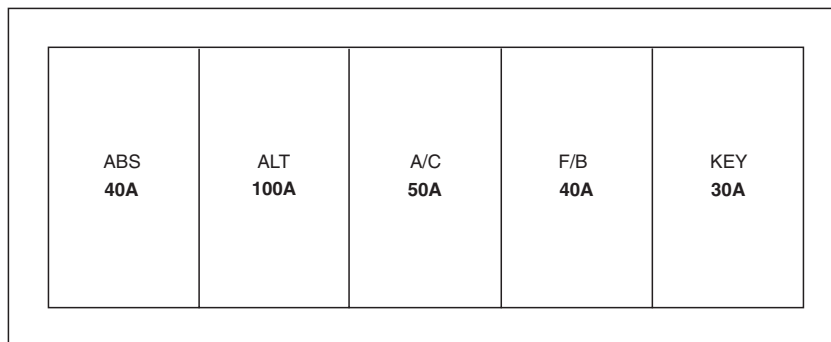

POWER DISTRIBUTION

EED1B50F

POWER DISTRIBUTION (1)

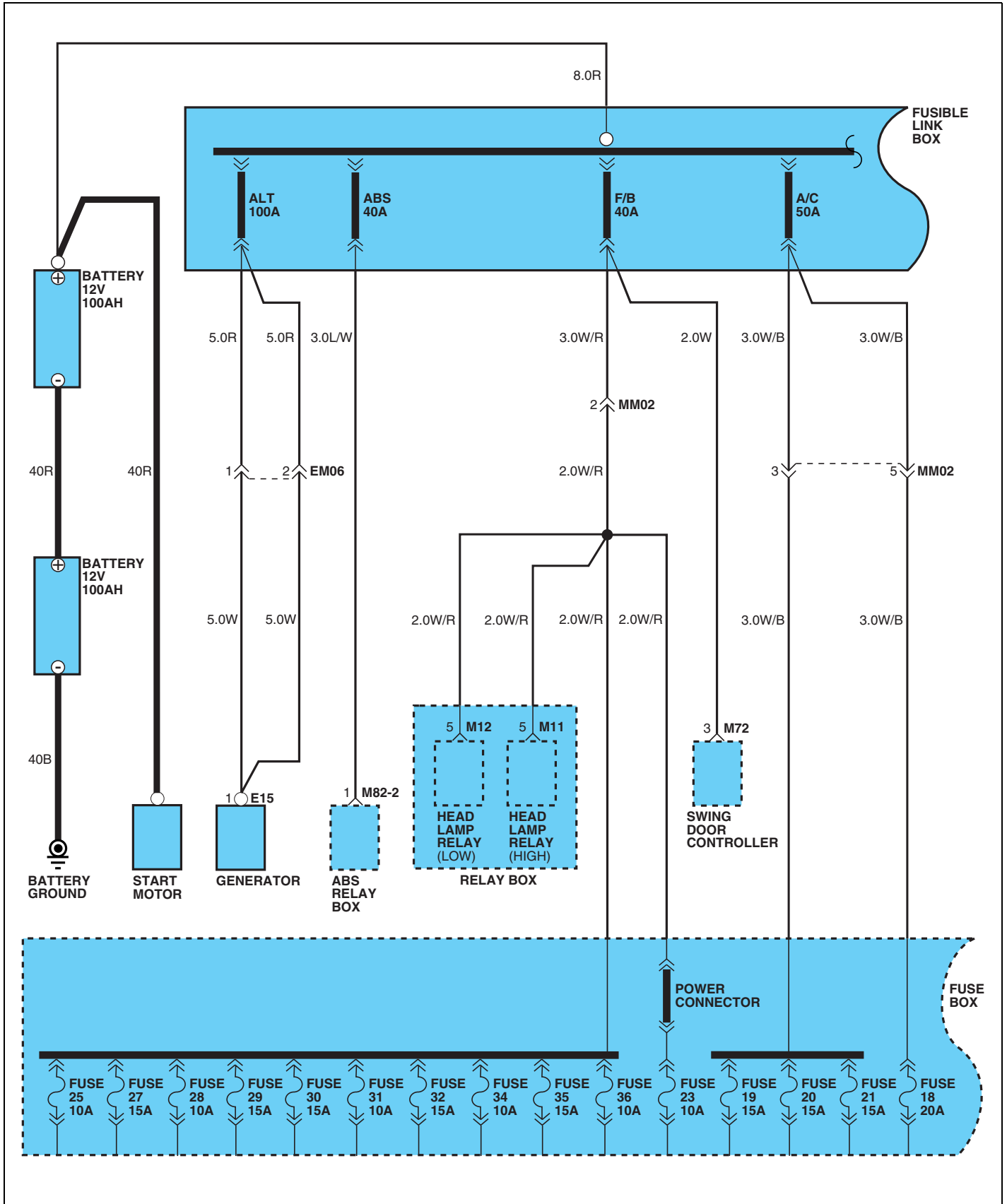

POWER DISTRIBUTION (2)

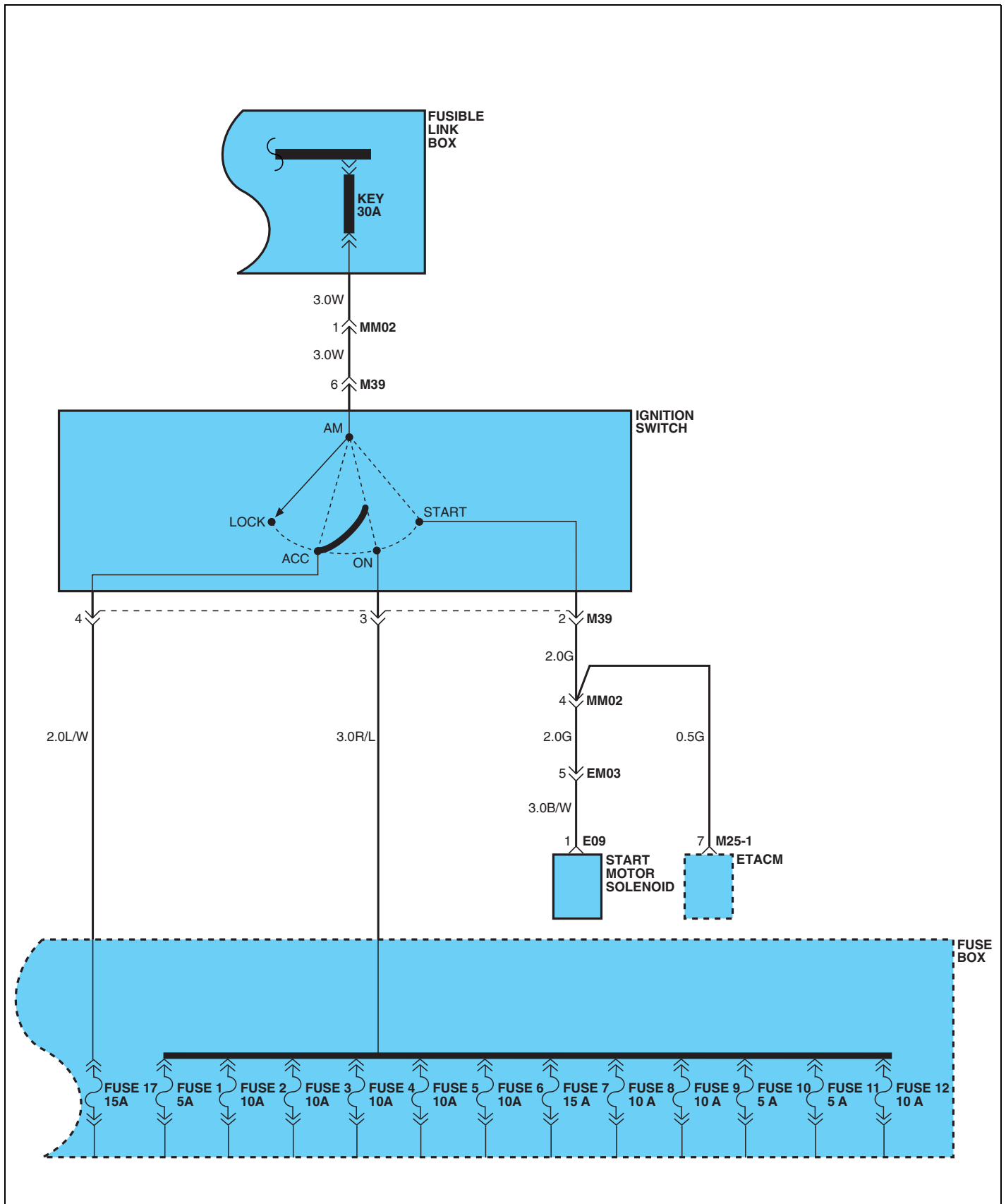

FUSE BOX DETAILS

E785EF75

FUSE BOX DETAILS (1)

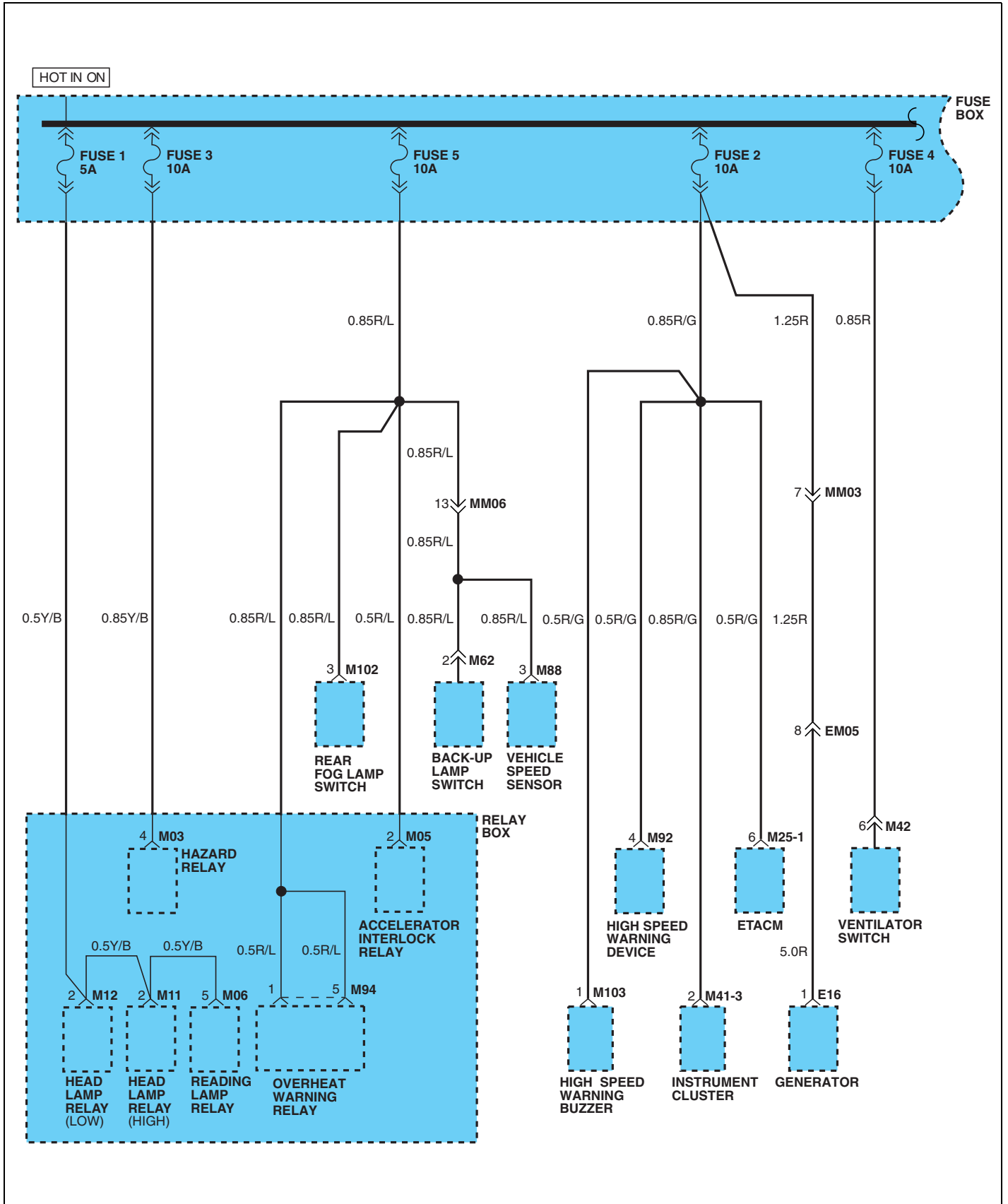

FUSE BOX DETAILS (2)

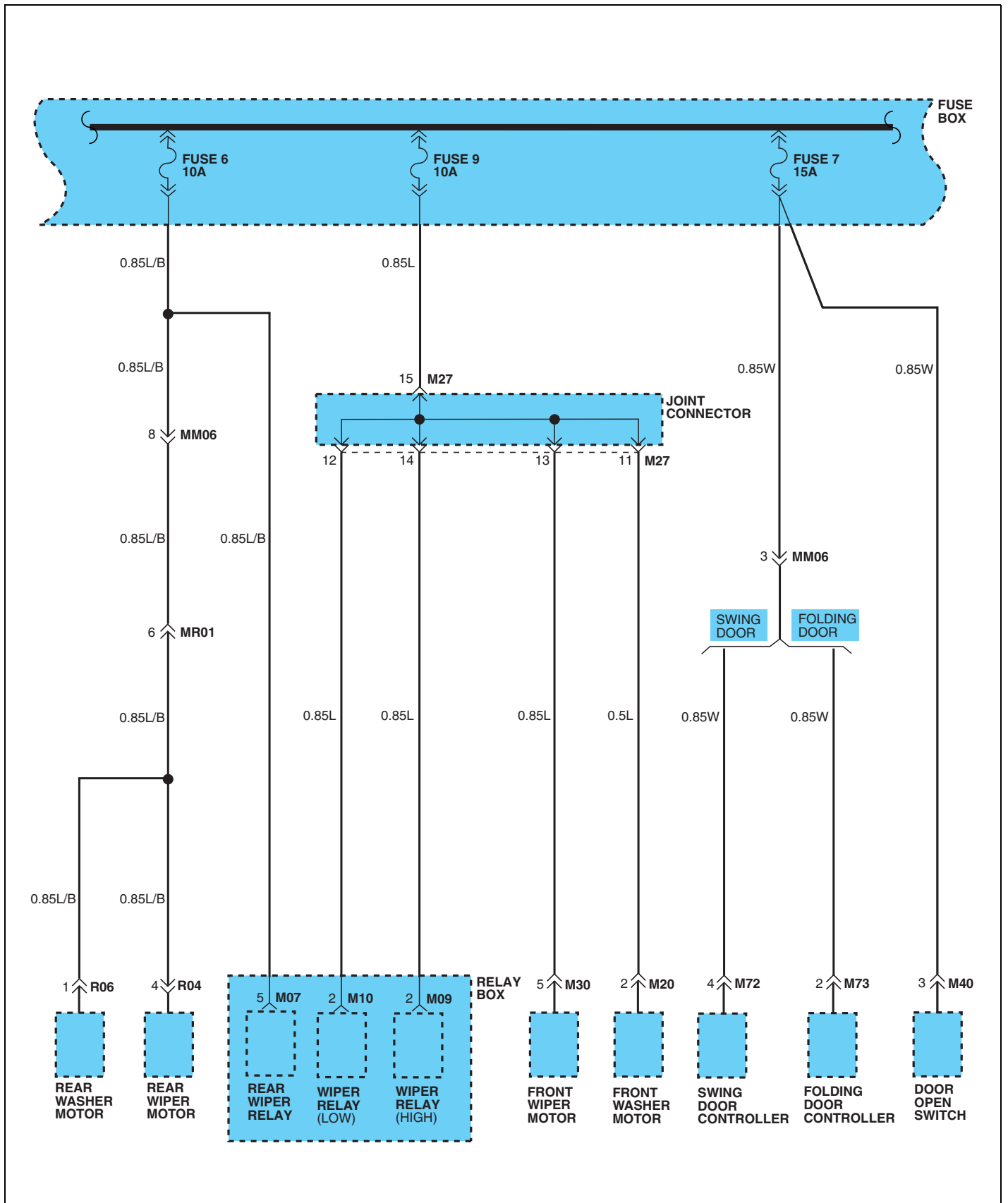

FUSE BOX DETAILS (3)

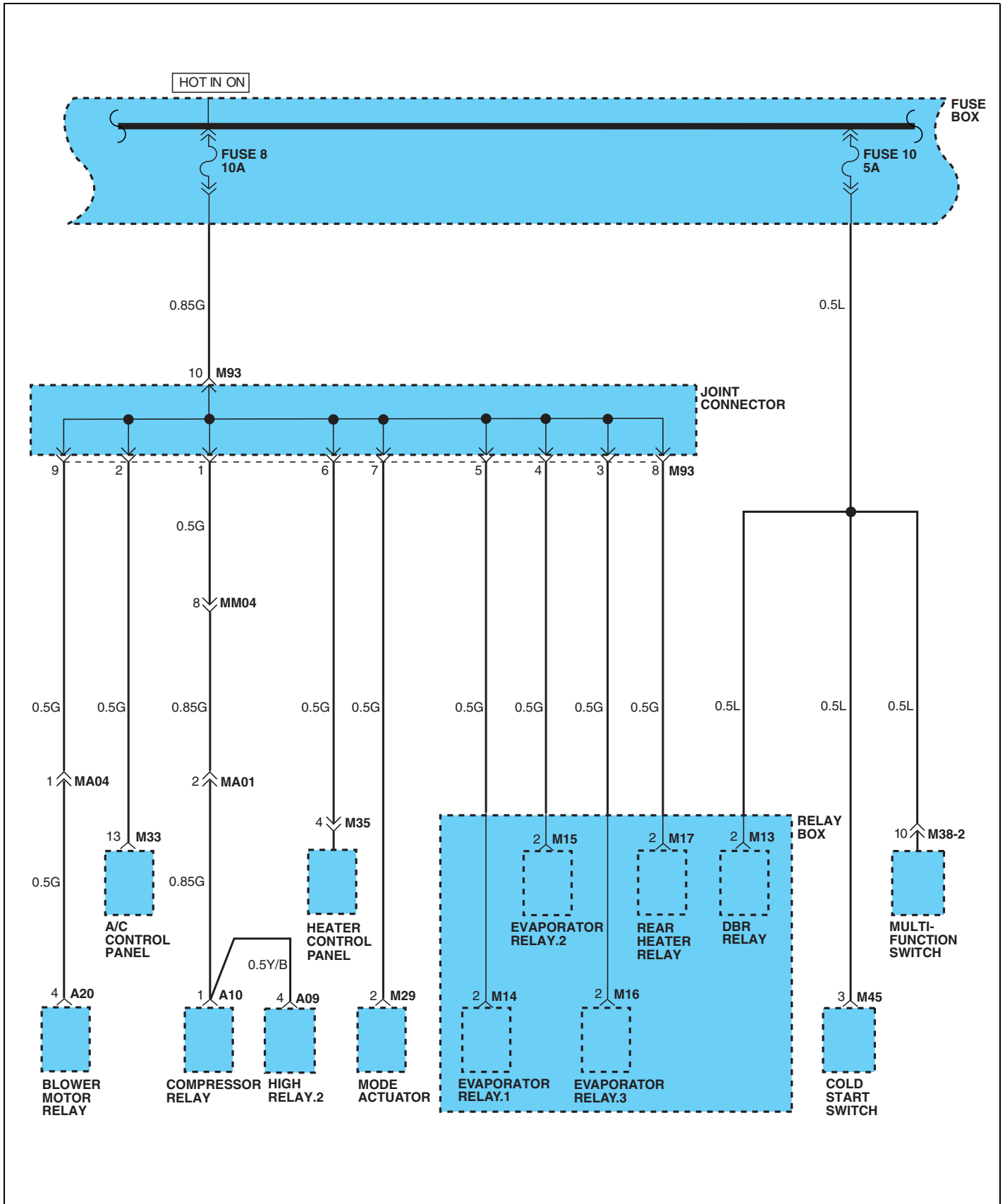

FUSE BOX DETAILS (4)

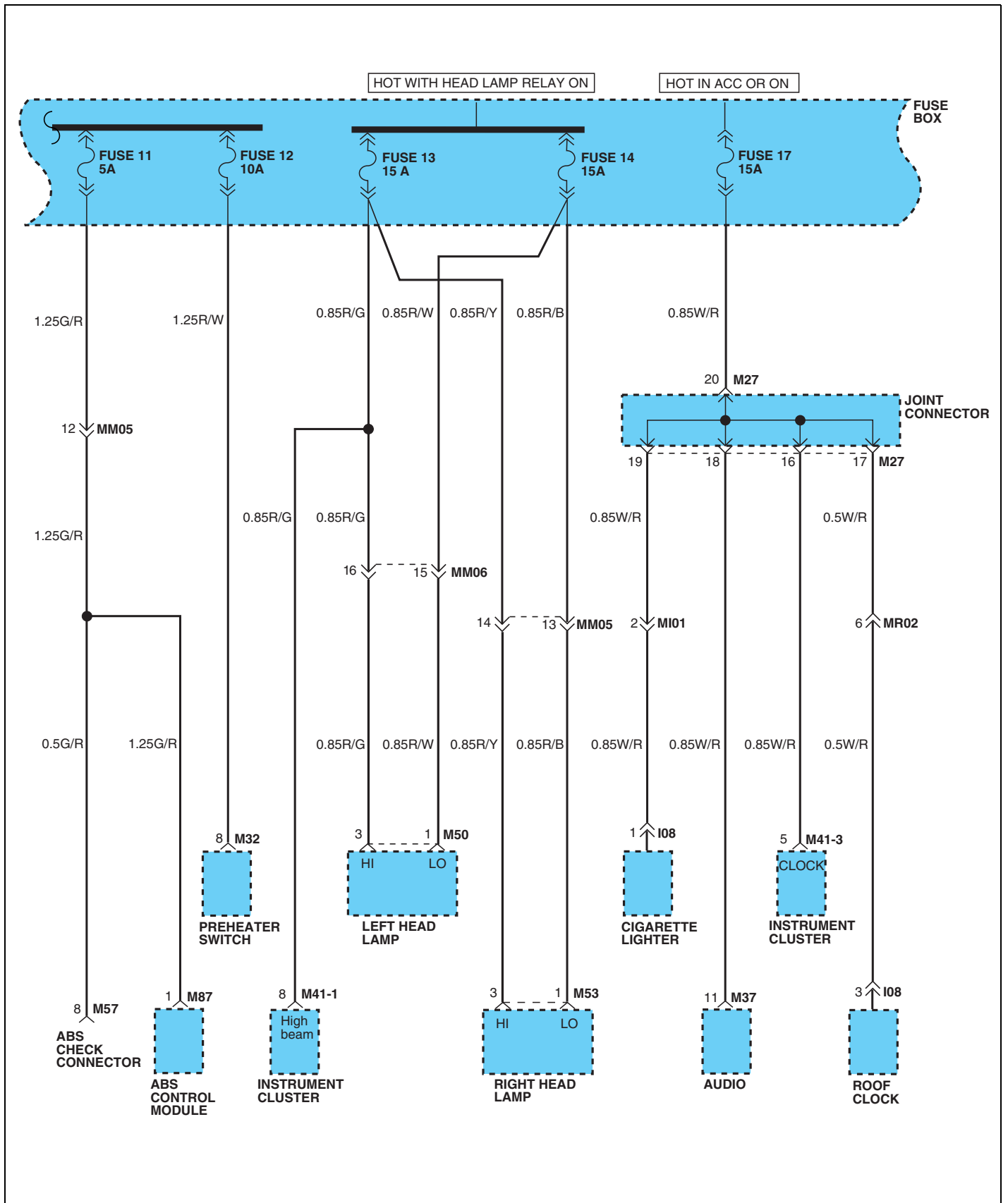

FUSE BOX DETAILS (5)

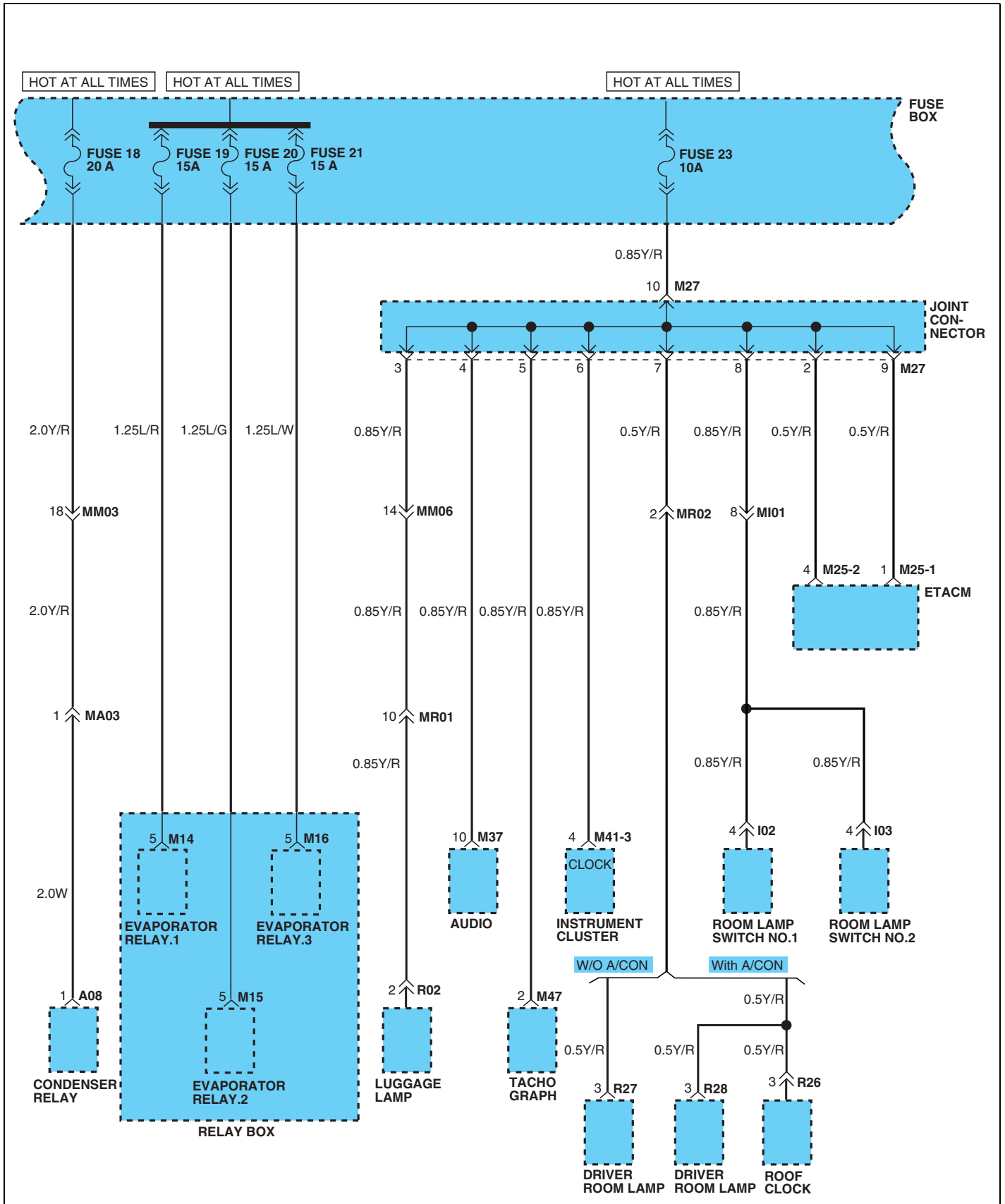

FUSE BOX DETAILS (6)

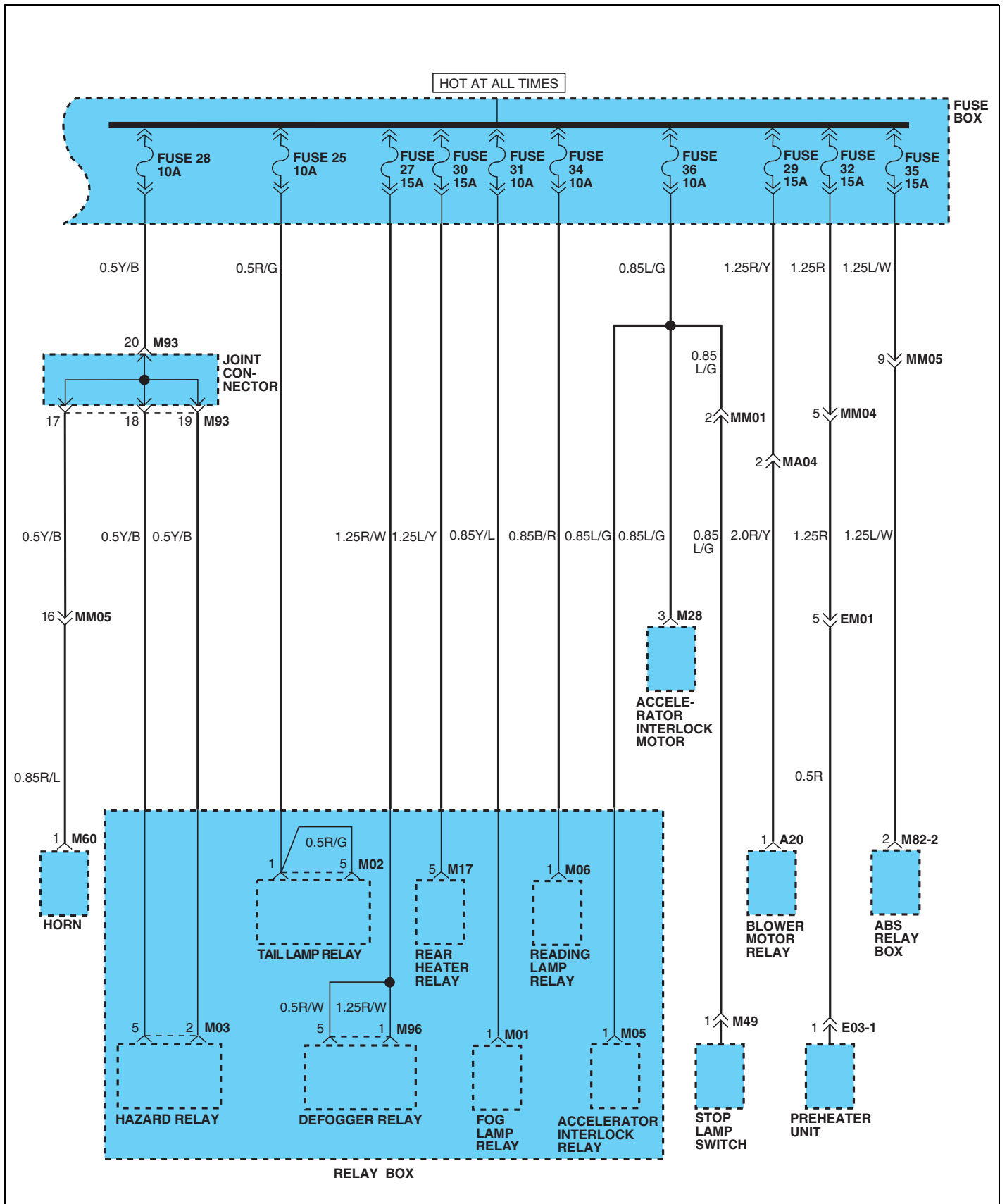

GROUND DISTRIBUTION

E2DE7D5D

GROUND DISTRIBUTION (1)

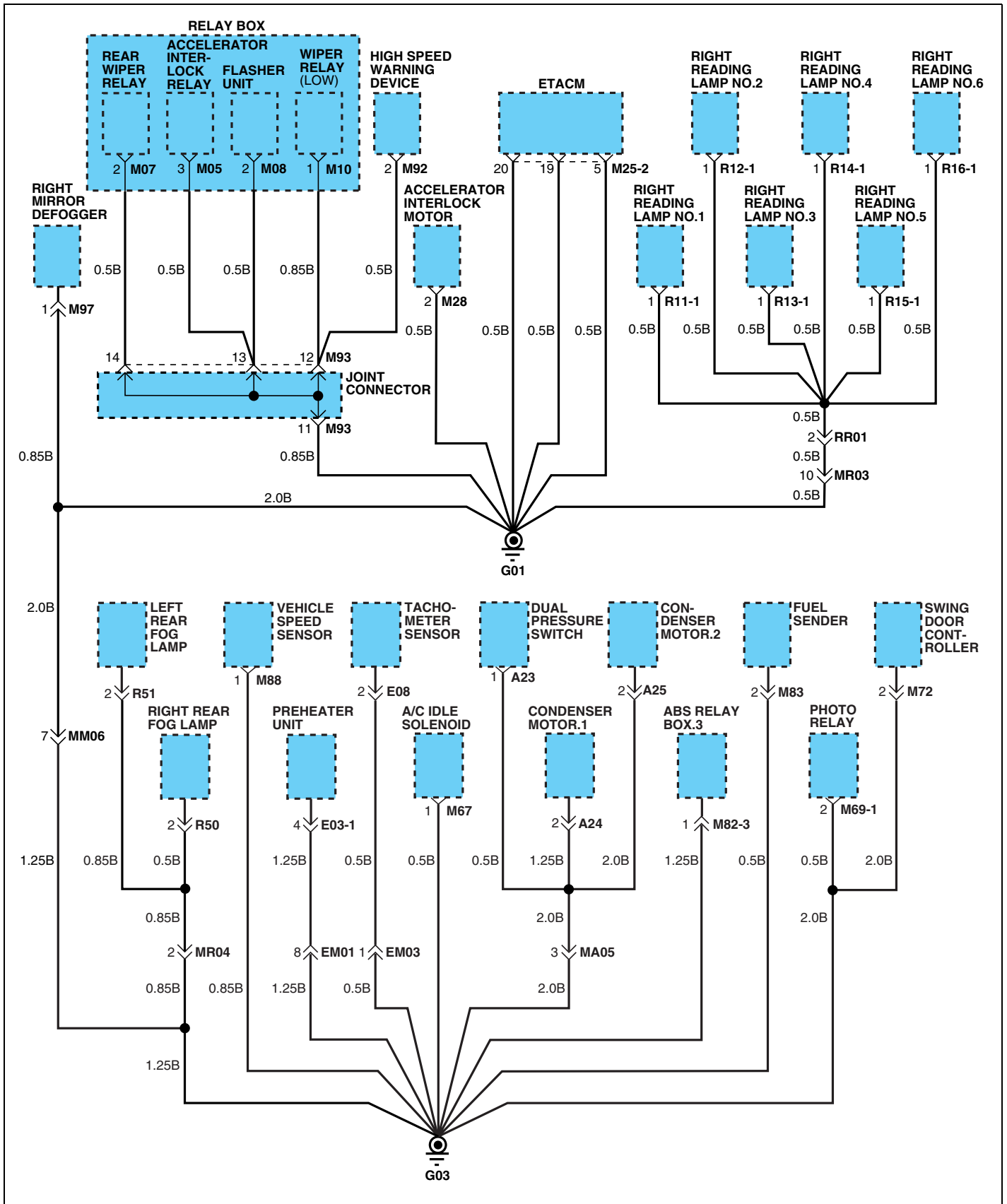

GROUND DISTRIBUTION (2)

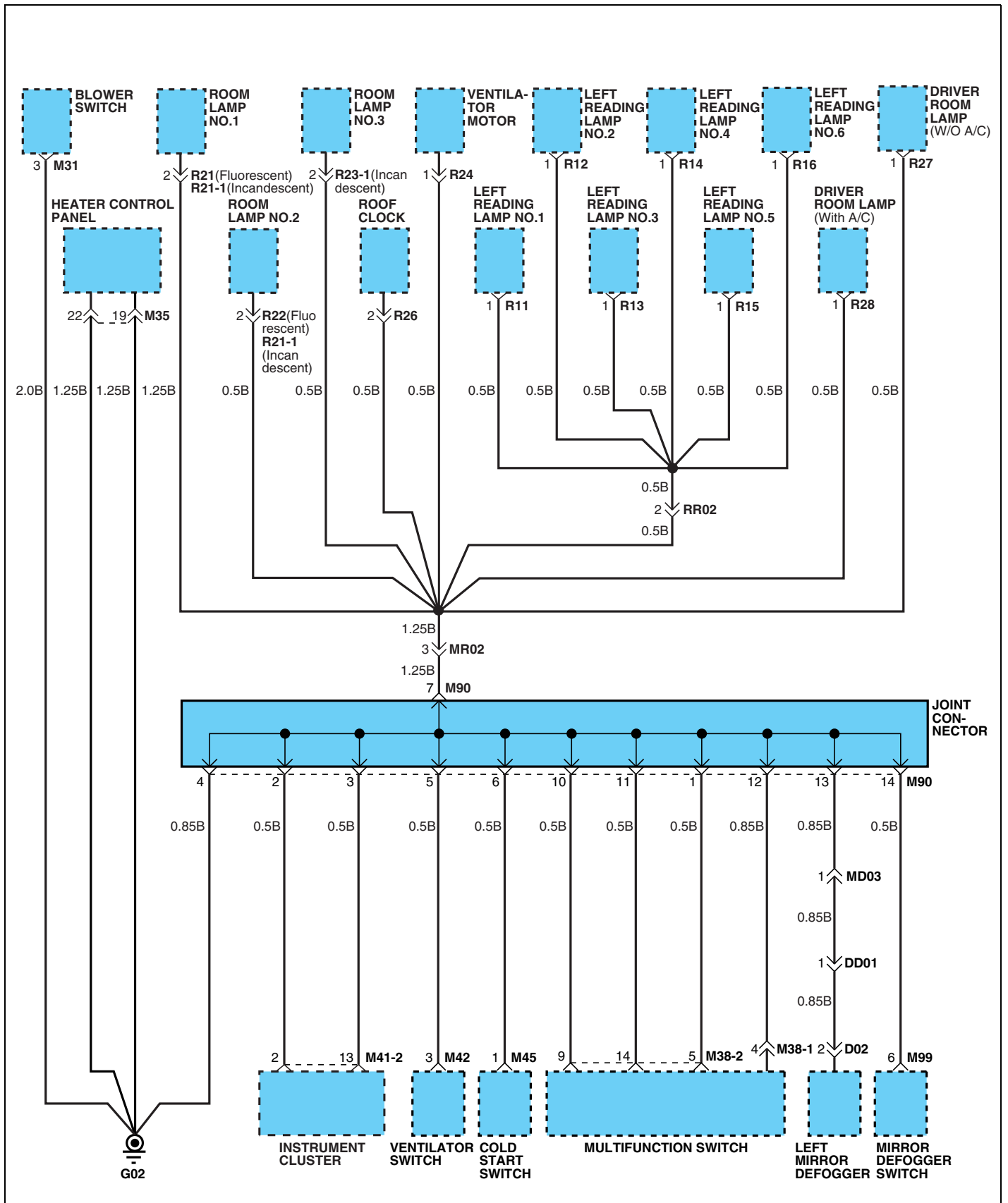

GROUND DISTRIBUTION (3)

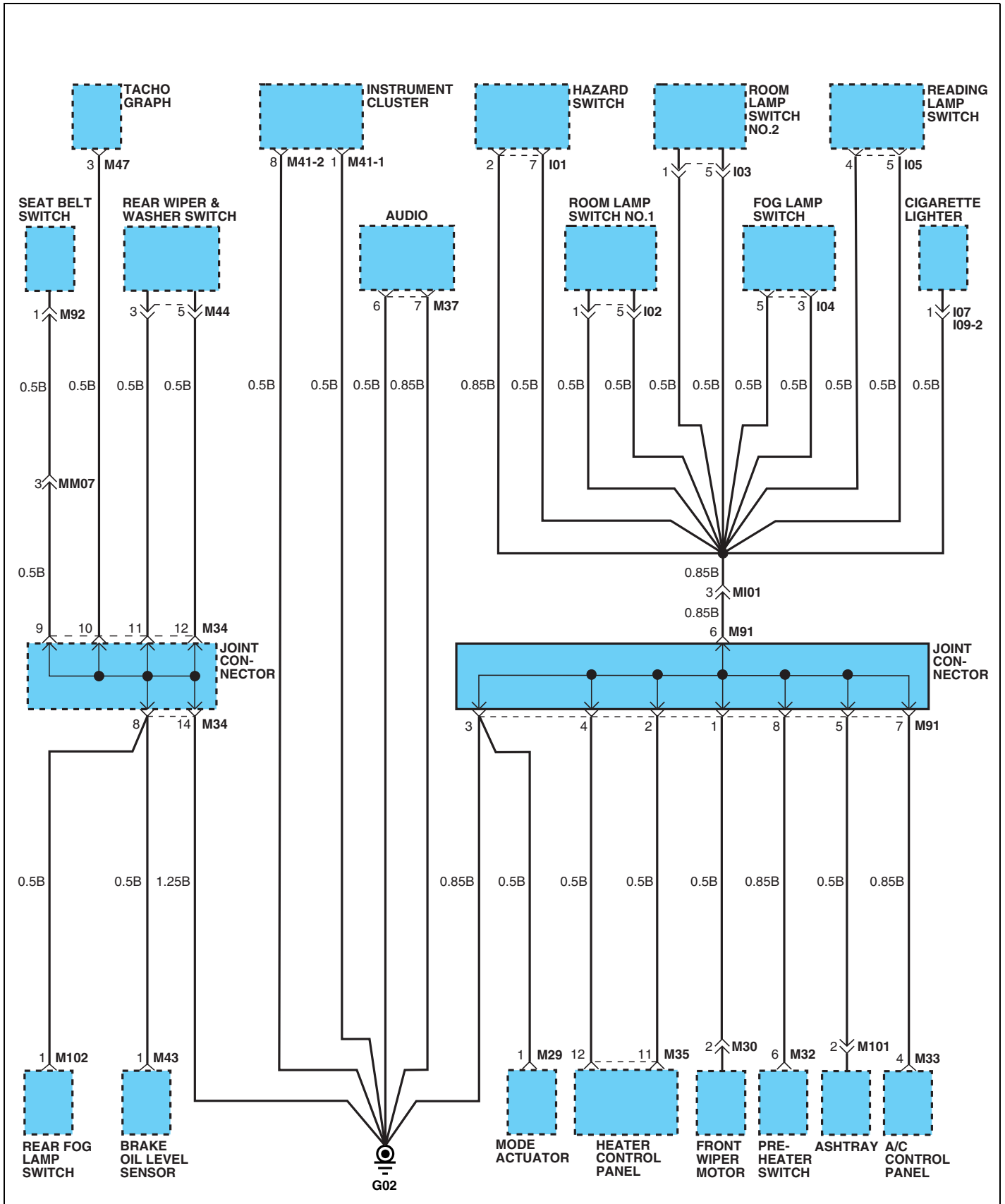

GROUND DISTRIBUTION (4)

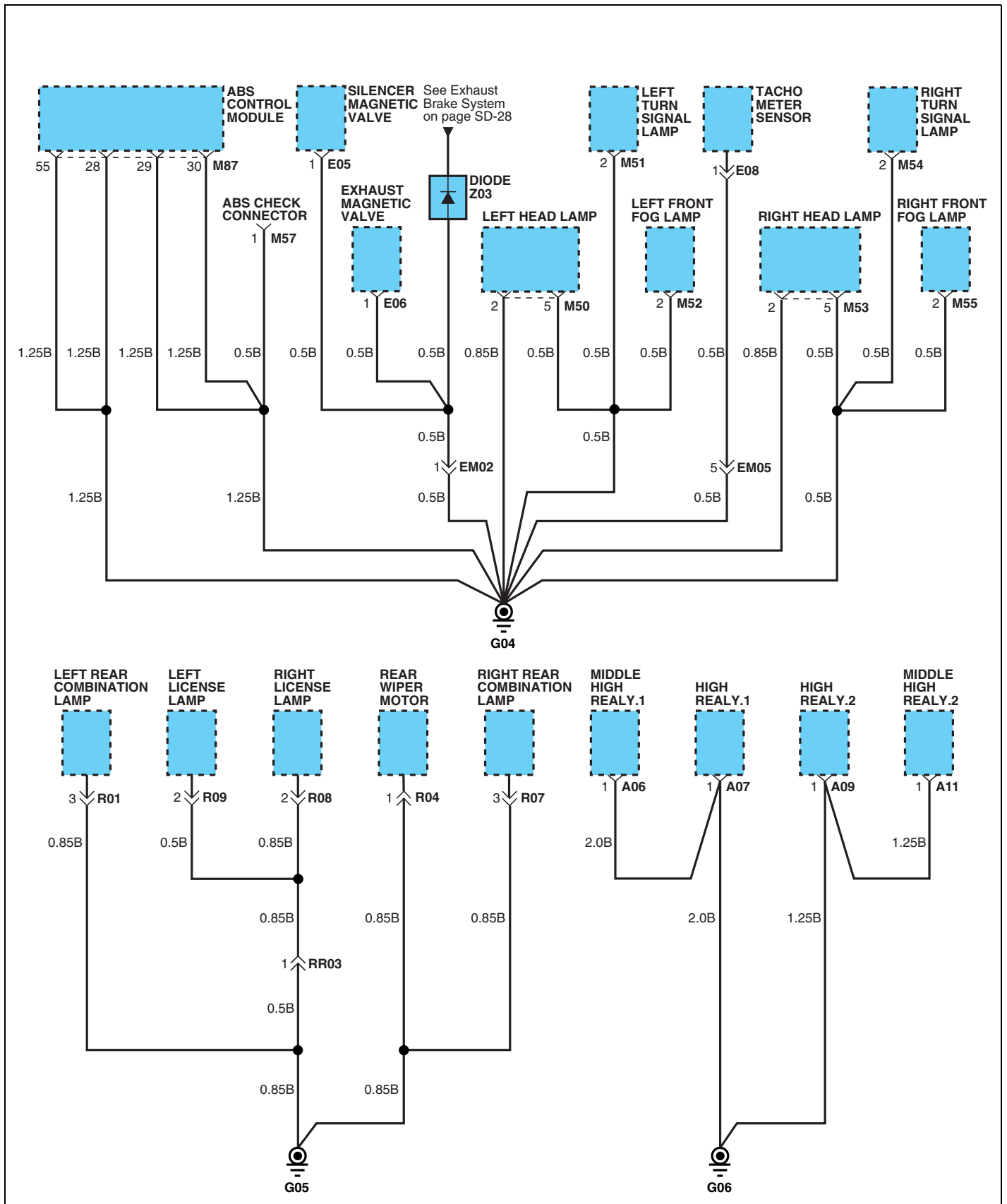

VEHICLE SPEED SENSOR & TACHOGRAPH

E0207ED2

VEHICLE SPEED SENSOR & TACHOGRAPH (1)

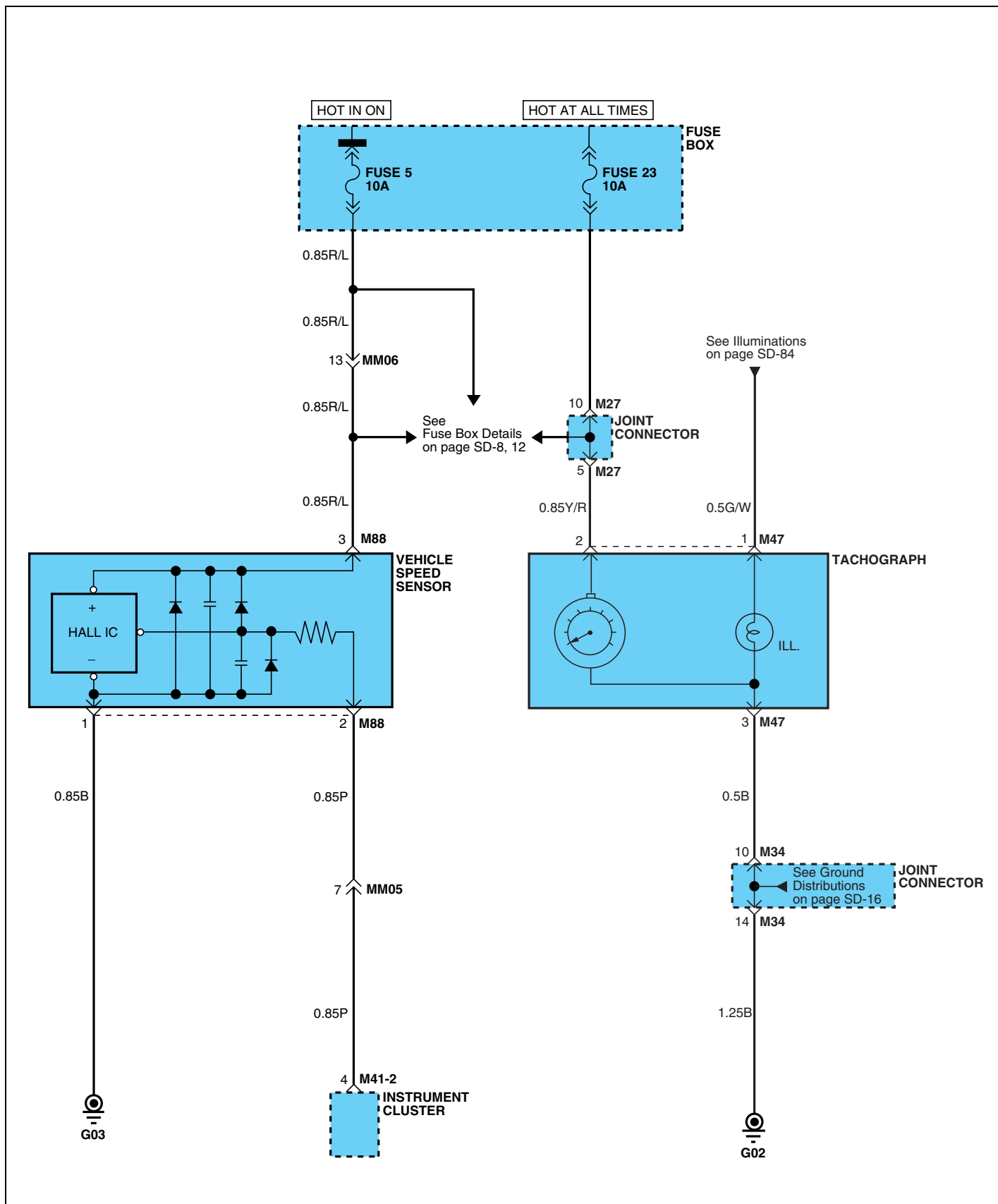

COMPONENT LOCATION INDEX

Components		Location reference-page
M27	Joint connector	CL- 2
M34	Joint connector	CL- 3
M41-2	Instrument cluster	CL- 3
M47	Tachograph	CL- 4
M88	Vehicle speed sensor	CL-10
Connectors		
MM05		CL- 6
MM06		CL- 6
Grounds		
G02		CL-19
G03		CL-19

STARTING & CHARGING SYSTEM

EDAC379A

STARTING & CHARGING SYSTEM (1)

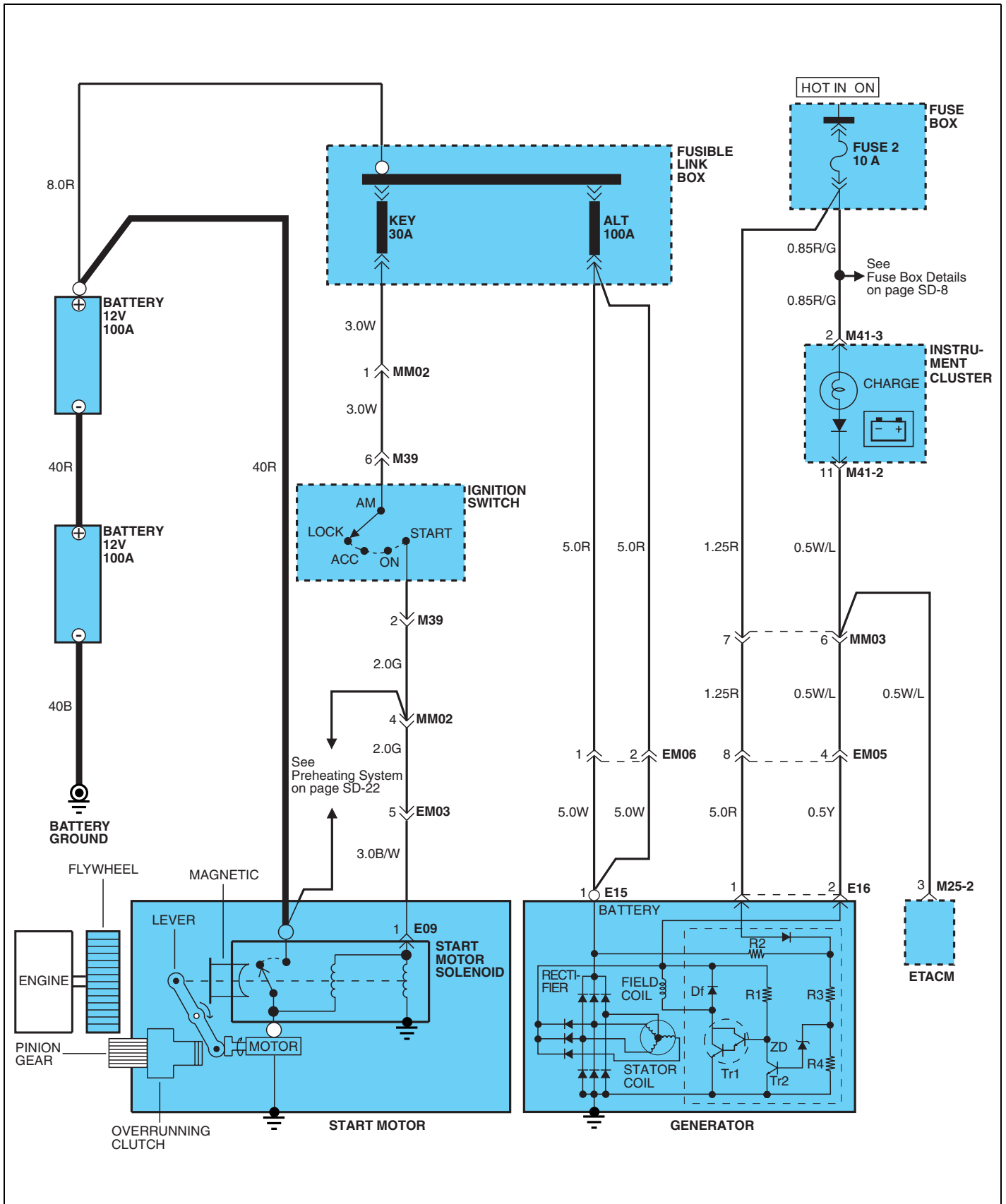

COMPONENT LOCATION INDEX

Components		Location reference-page
E09	Start motor solenoid	CL-13
E15	Generator	CL-13
E16	Generator	CL-13
M39	Ignition switch	CL- 3
M25-2	ETACM	CL- 2
M41-1	Instrument cluster	CL- 3
M41-2	Instrument cluster	CL- 3
Connectors		
EM03		CL-11
EM05		CL-12
EM06		CL-12
MM02		CL- 6
MM03		CL- 6

PREHEATING SYSTEM

E6EE8EAA

PREHEATING SYSTEM (1)

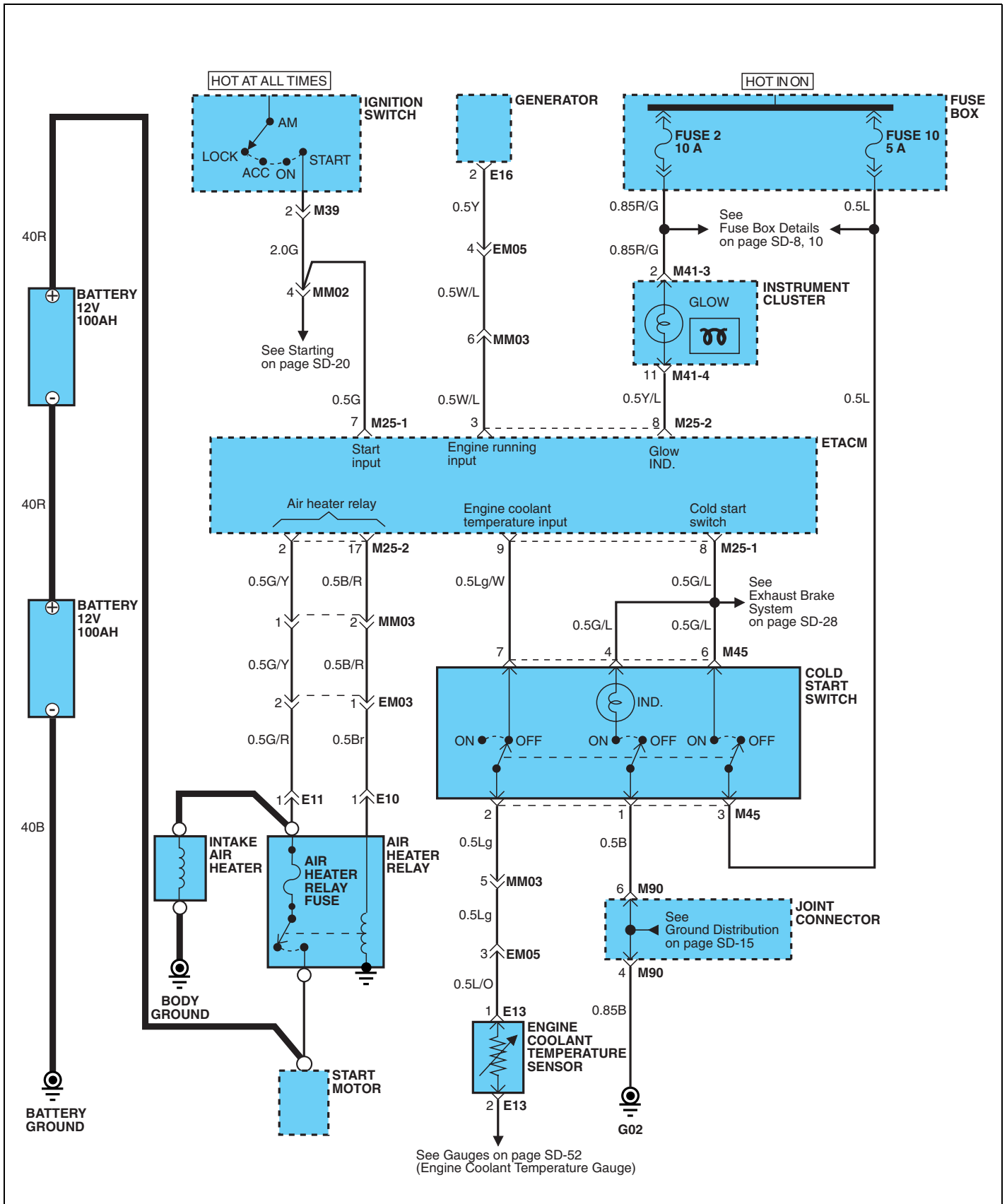

COMPONENT LOCATION INDEX

Components		Location reference-page
E10	Air heater relay	CL-13
E11	Air heater relay fuse	CL-13
E13	Engine coolant temperature sensor	CL-13
E16	Generator	CL-13
M25-1	ETACM	CL- 2
M25-2	ETACM	CL- 2
M39	Ignition switch	CL- 3
M41-1	Instrument cluster	CL- 3
M41-3	Instrument cluster	CL- 3
M45	Cold start switch	CL- 3
Connectors		
EM03		CL-11
EM05		CL-12
MM03		CL- 6
Grounds		
G02		CL-19

OVERHEAT WARNING SYSTEM

EAC0F060

OVERHEAT WARNING SYSTEM (1)

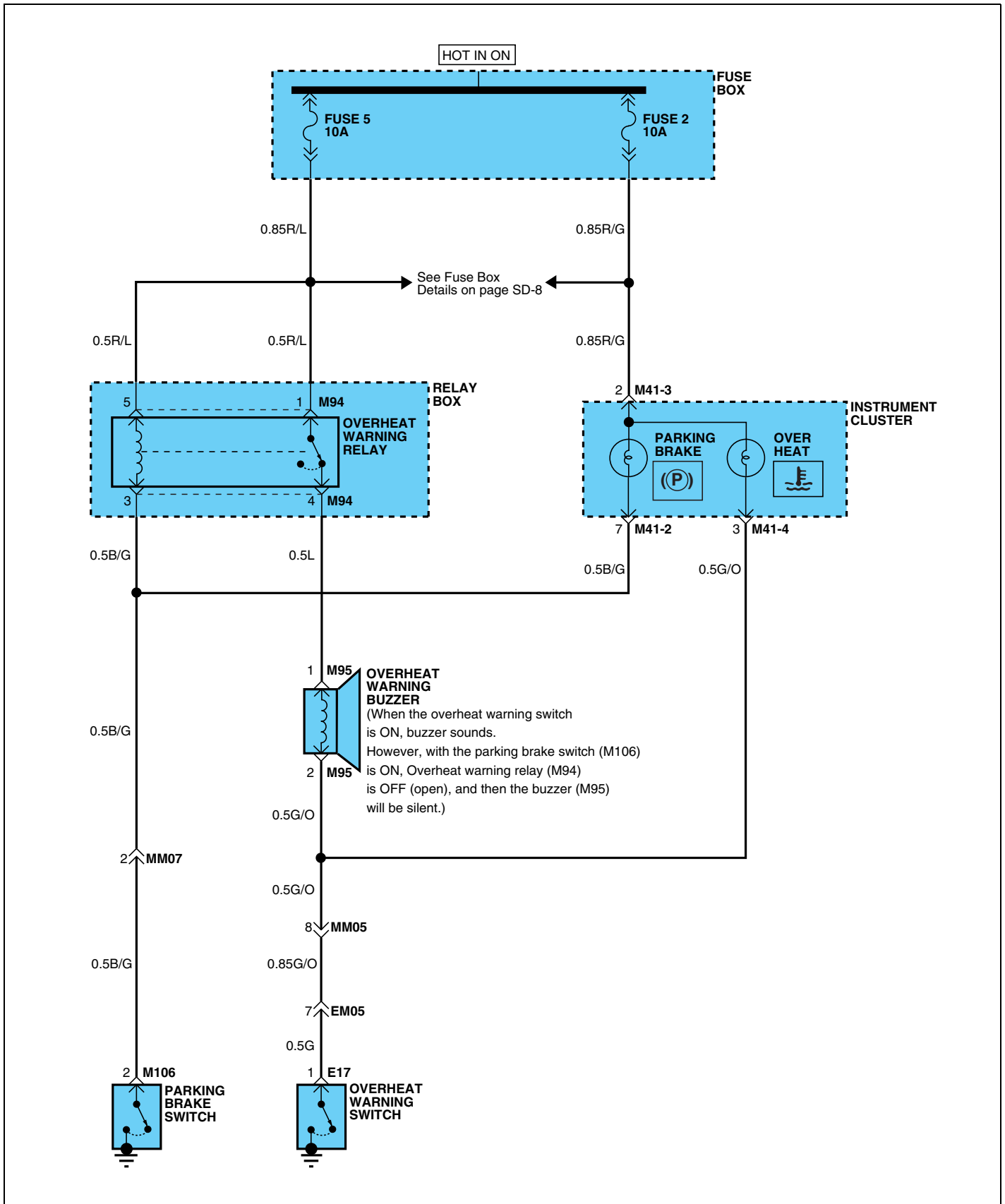

COMPONENT LOCATION INDEX

Components		Location reference-page
E17	Overheat warning switch	CL-13
M41-2,3,4	Instrument cluster	CL- 3
M91	Parking brake switch	CL- 4
M94	Overheat warning switch	CL- 5
M95	Overheat warning buzzer	CL- 5
Connectors		
EM05		CL-12
MM05		CL- 6
MM07		CL- 6

PREHATER CONTROLS

EE6E8D1A

PREHATER CONTROLS (1)

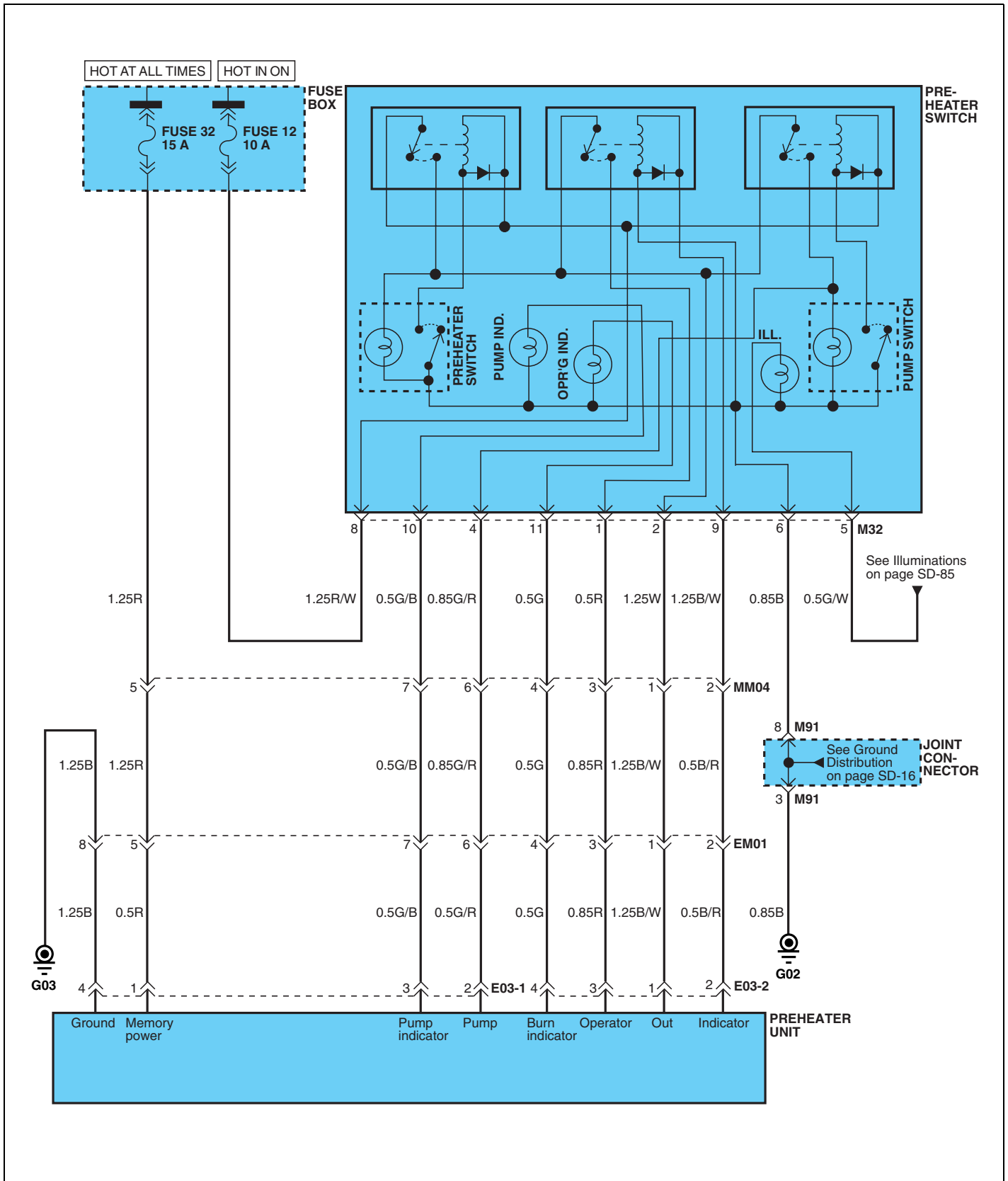

COMPONENT LOCATION INDEX

Components		Location reference-page
E03-1	Preheater unit	CL-13
E03-2	Preheater unit	CL-13
M32	Preheater switch	CL- 3
M91	Joint connector	CL- 4
Connectors		
EM01		CL-11
MM04		CL- 6
Grounds		
G02		CL-19
G03		CL-19

EXHAUST BRAKE SYSTEM

E6B242FF

EXHAUST BRAKE SYSTEM (1)

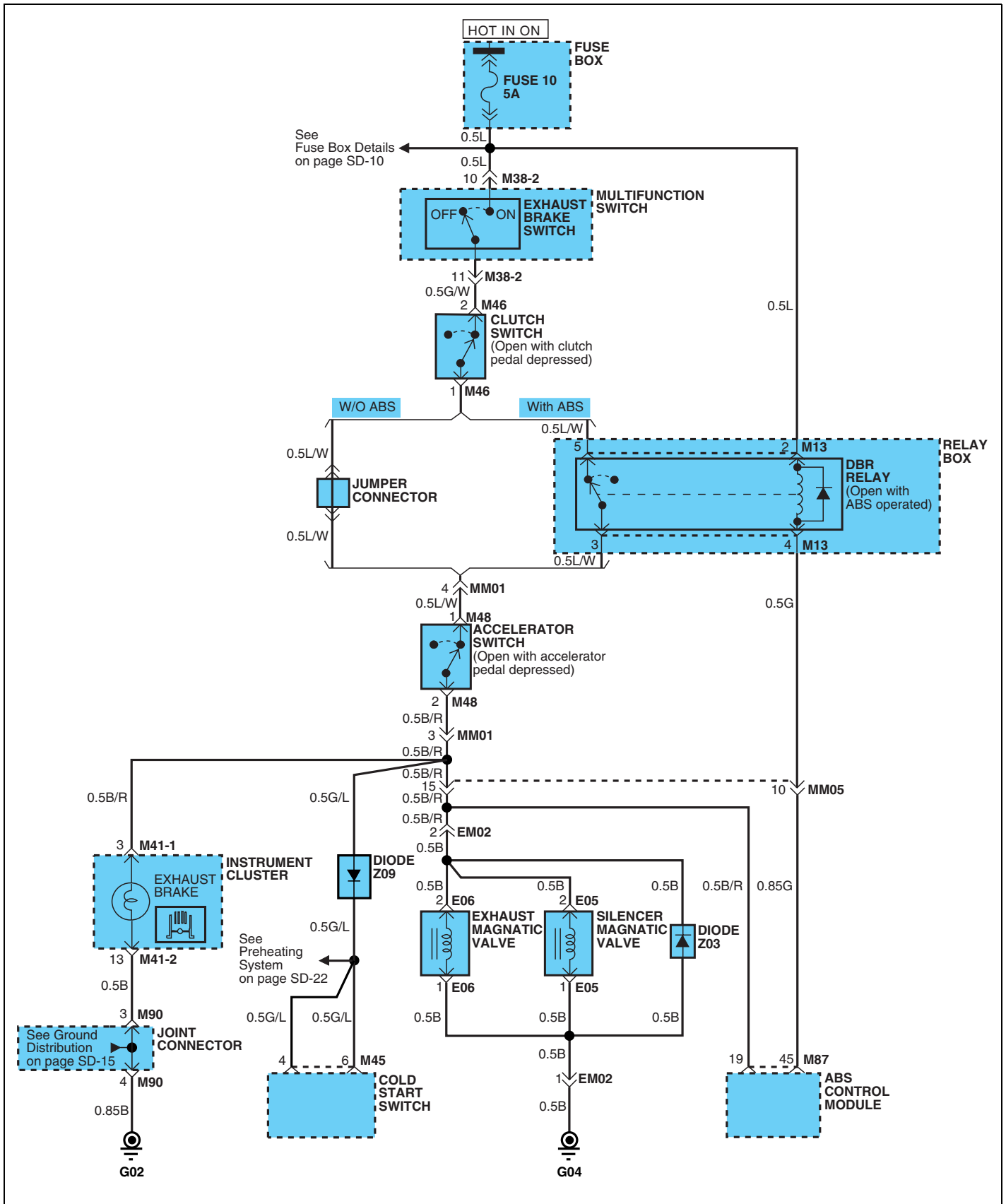

COMPONENT LOCATION INDEX

Components		Location reference-page
E05	Silencer magnetic valve	CL-13
E06	Exhaust magnetic valve	CL-13
M13	DBR relay	CL- 2
M38-2	Multifunction switch	CL- 3
M41-1,2	Instrument cluster	CL- 3
M45	Cold start switch	CL- 3
M46	Clutch switch	CL- 4
M48	Accelerator switch	CL- 4
M87	ABS control module	CL-10
M90	Joint connector	CL- 4
Connectors		
EM02		CL-11
MM01		CL- 6
MM05		CL- 6
Grounds		
G02		CL-19
G04		CL-19
Diodes		
Z03		CL-20
Z09		CL-20

ACCELERATOR INTERLOCK SYSTEM

ECFEF2F3

ACCELERATOR INTERLOCK SYSTEM (1)

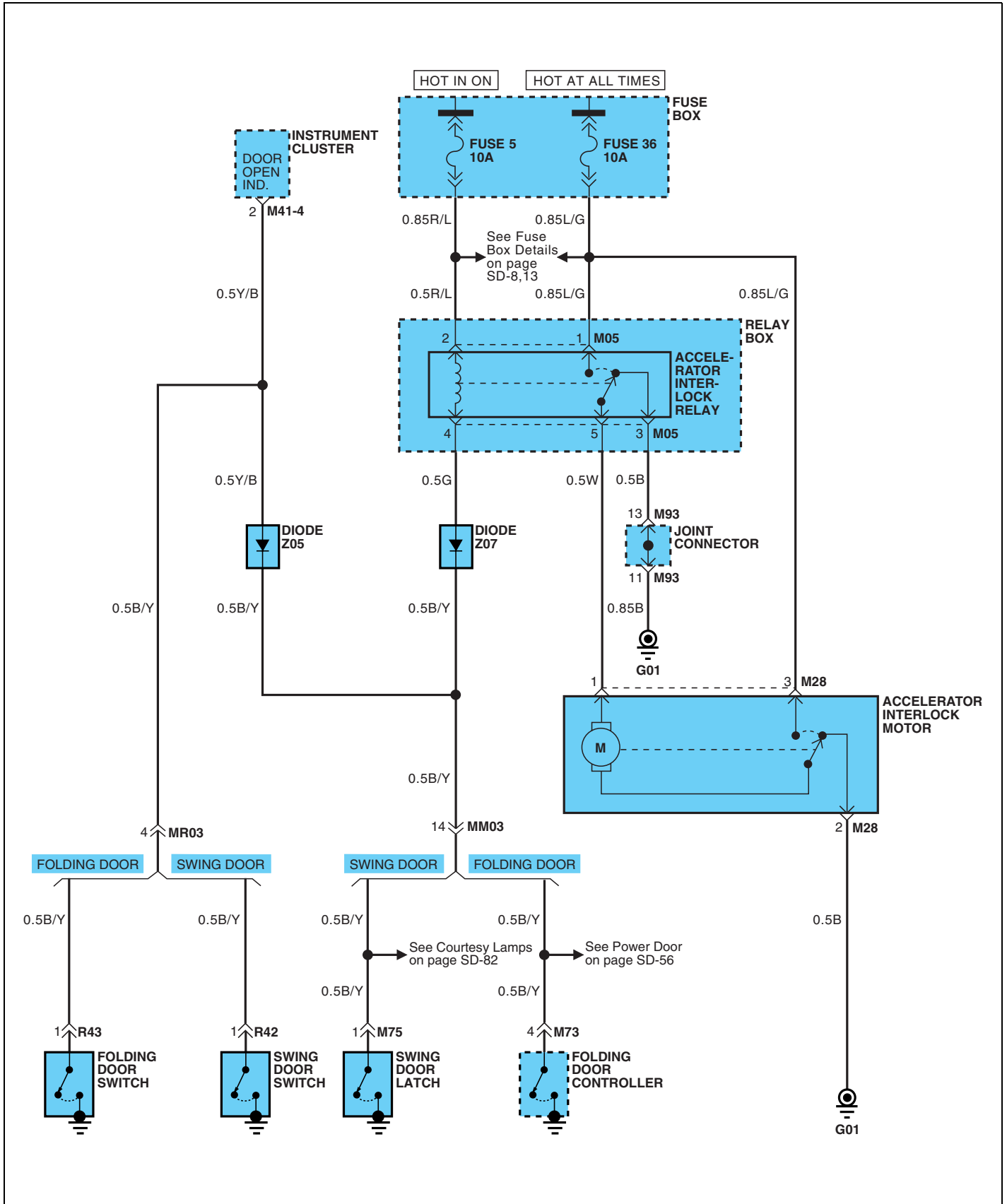

COMPONENT LOCATION INDEX

Components		Location reference-page
M05	Accelerator inter lock relay	CL- 2
M28	Accelerator interlock motor	CL- 2
M34	Joint connector	CL- 3
M41-4	Instrument cluster	CL- 3
M73	Folding door controller	CL- 9
M75	Swing door latch	CL- 8
M93	Joint connector	CL- 4
R42	Swing door switch	CL-18
R43	Folding door switch	CL-18
Connectors		
MM03		CL- 6
MR03		CL- 6
Grounds		
G01		CL-19
Diodes		
Z05		CL-20
Z07		CL-20

ANTI-LOCK BRAKE SYSTEM (ABS) E7F71CE1

ANTI-LOCK BRAKE SYSTEM (ABS) (1)

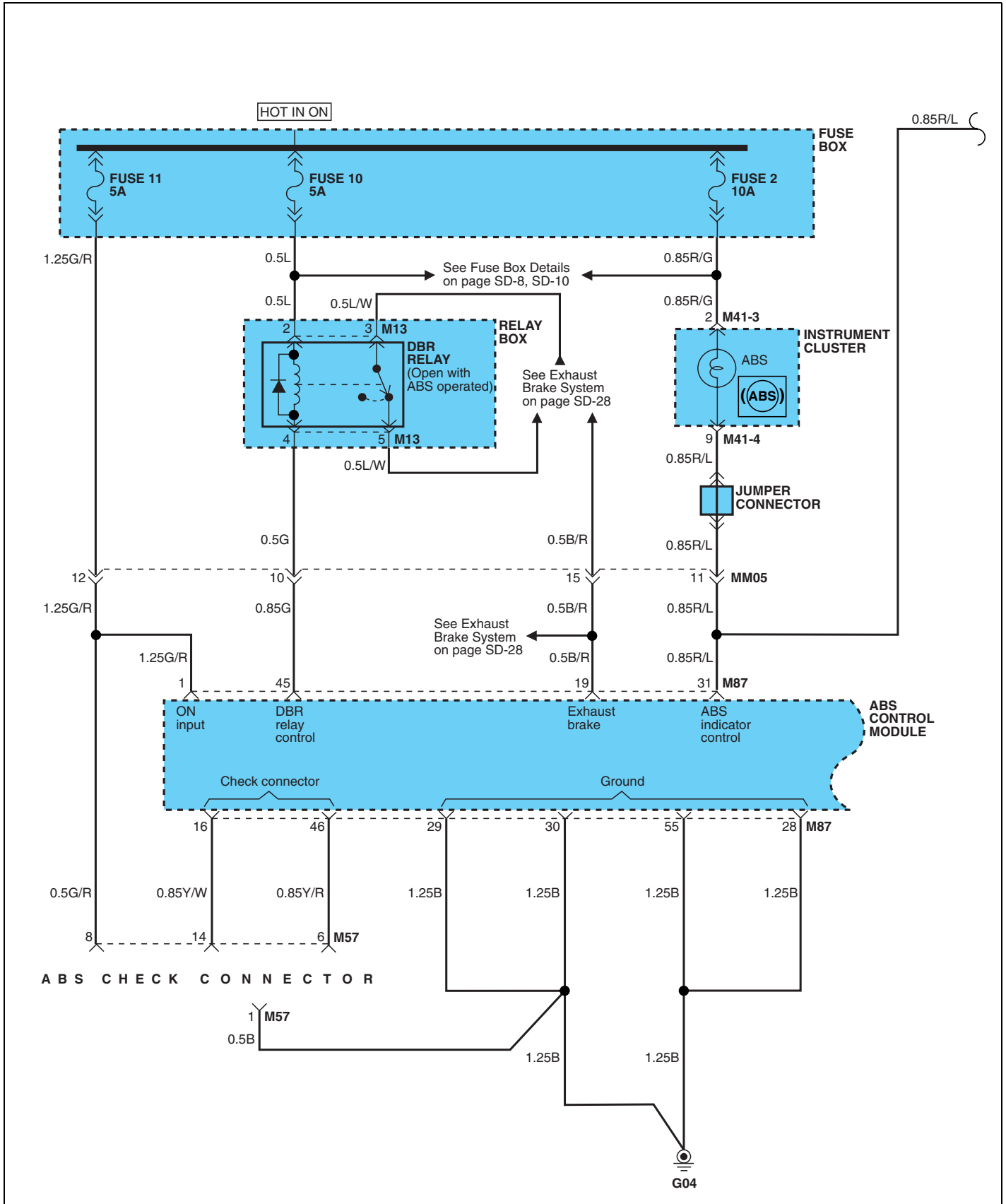

ANTI-LOCK BRAKE SYSTEM (ABS) (2)

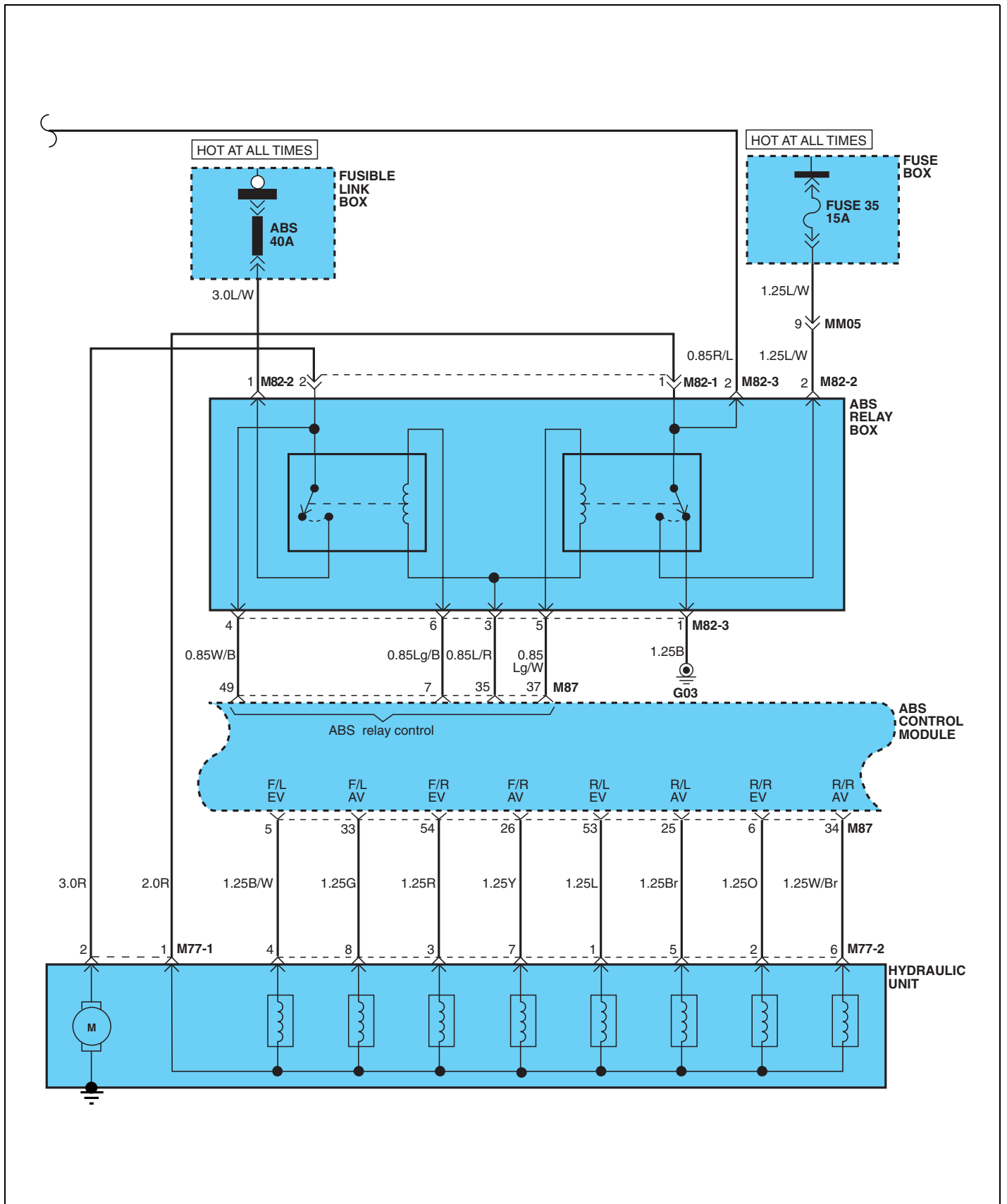

ANTI-LOCK BRAKE SYSTEM (ABS) (3)

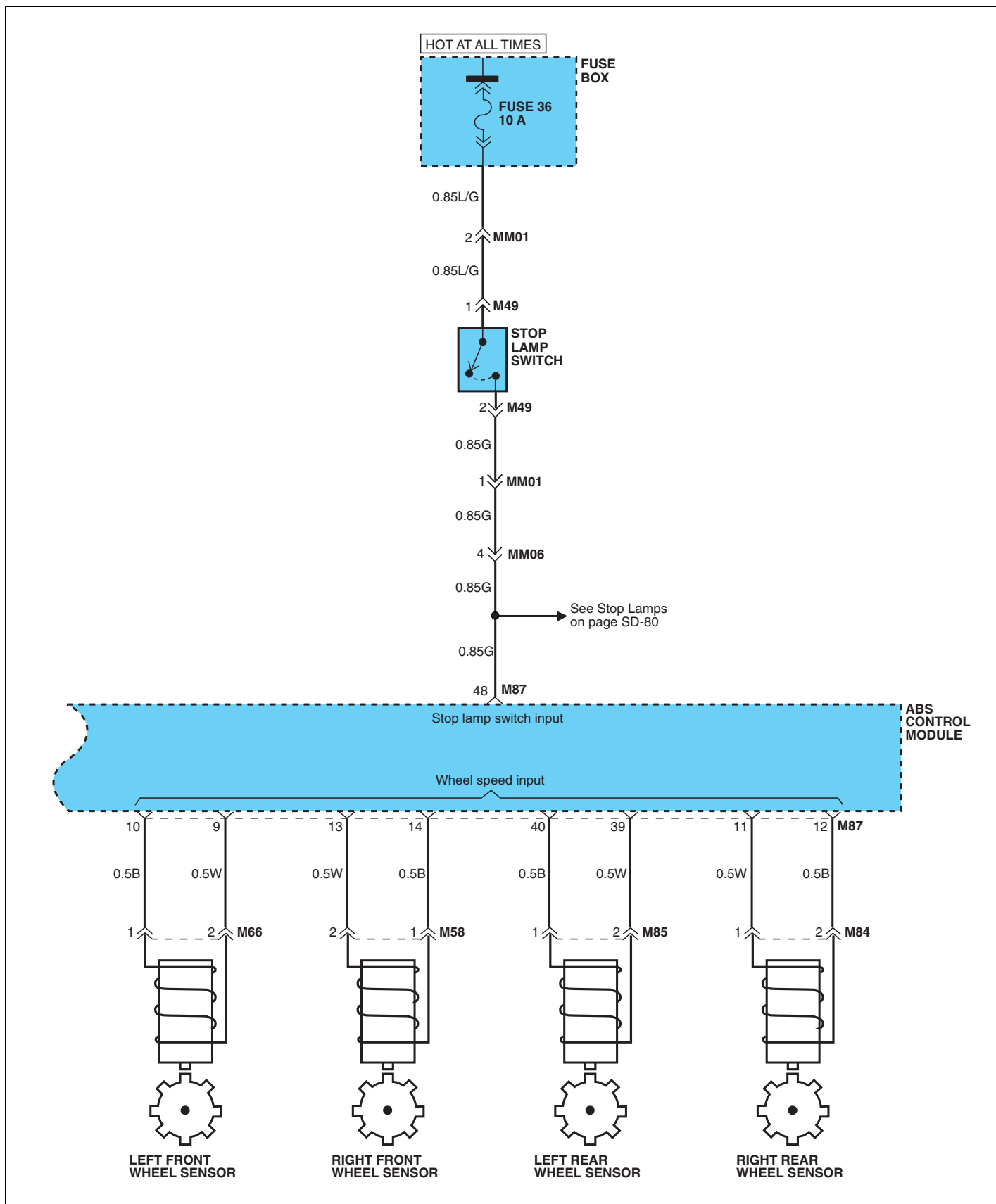

COMPONENT LOCATION INDEX

Components		Location reference-page
M13	DBR relay	CL- 2
M41-3	Instrument cluster	CL- 3
M41-4	Instrument cluster	CL- 3
M49	Stop lamp switch	CL- 4
M57	ABS check connector	CL- 7
M77-1	Hydraulic unit	CL- 9
M77-2	Hydraulic unit	CL- 9
M82-1	ABS relay box.1	CL- 9
M82-2	ABS relay box.2	CL- 9
M82-3	ABS relay box.3	CL- 9
M84	Right rear wheel sensor	CL-10
M85	Left rear wheel sensor	CL-10
M87	ABS control module	CL-10
Connectors		
MM01		CL- 6
MM05		CL- 6
MM06		CL- 6
Grounds		
G03		CL-19
G04		CL-19

CLOCK & CIGARETTE LIGHTER

E4E8AADC

CLOCK & CIGARETTE LIGHTER (1)

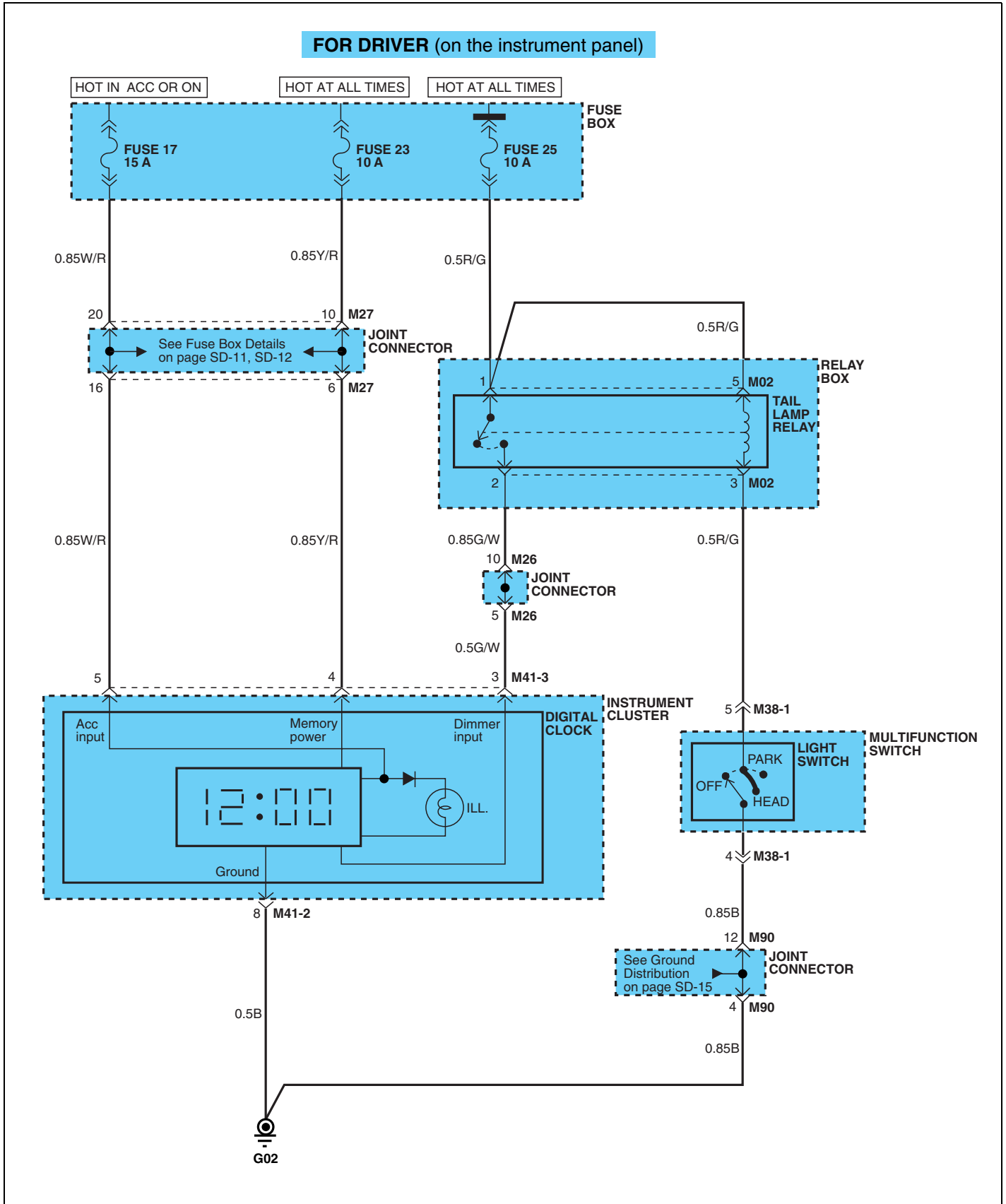

CLOCK & CIGARETTE LIGHTER (2)

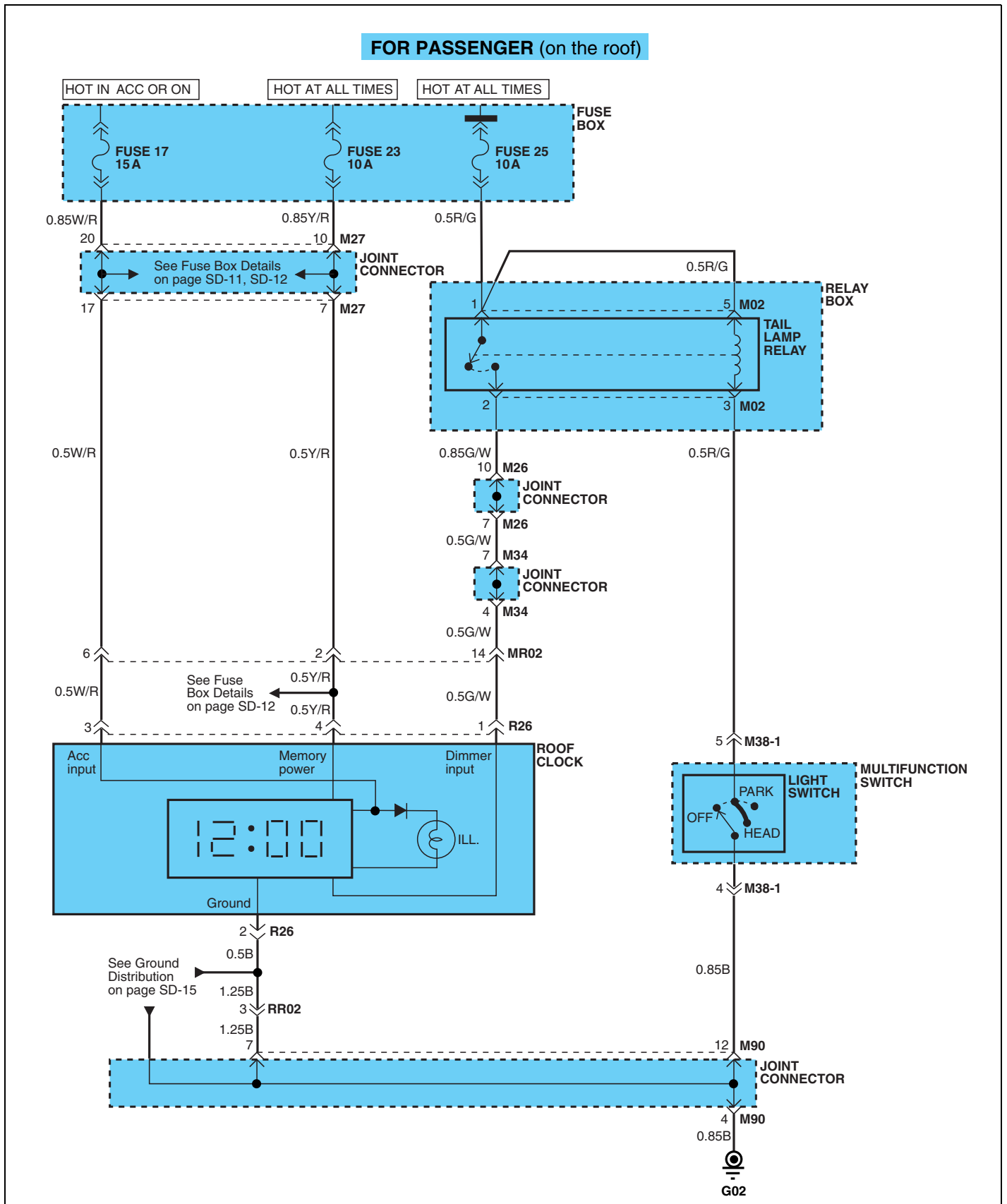

CLOCK & CIGARETTE LIGHTER (3)

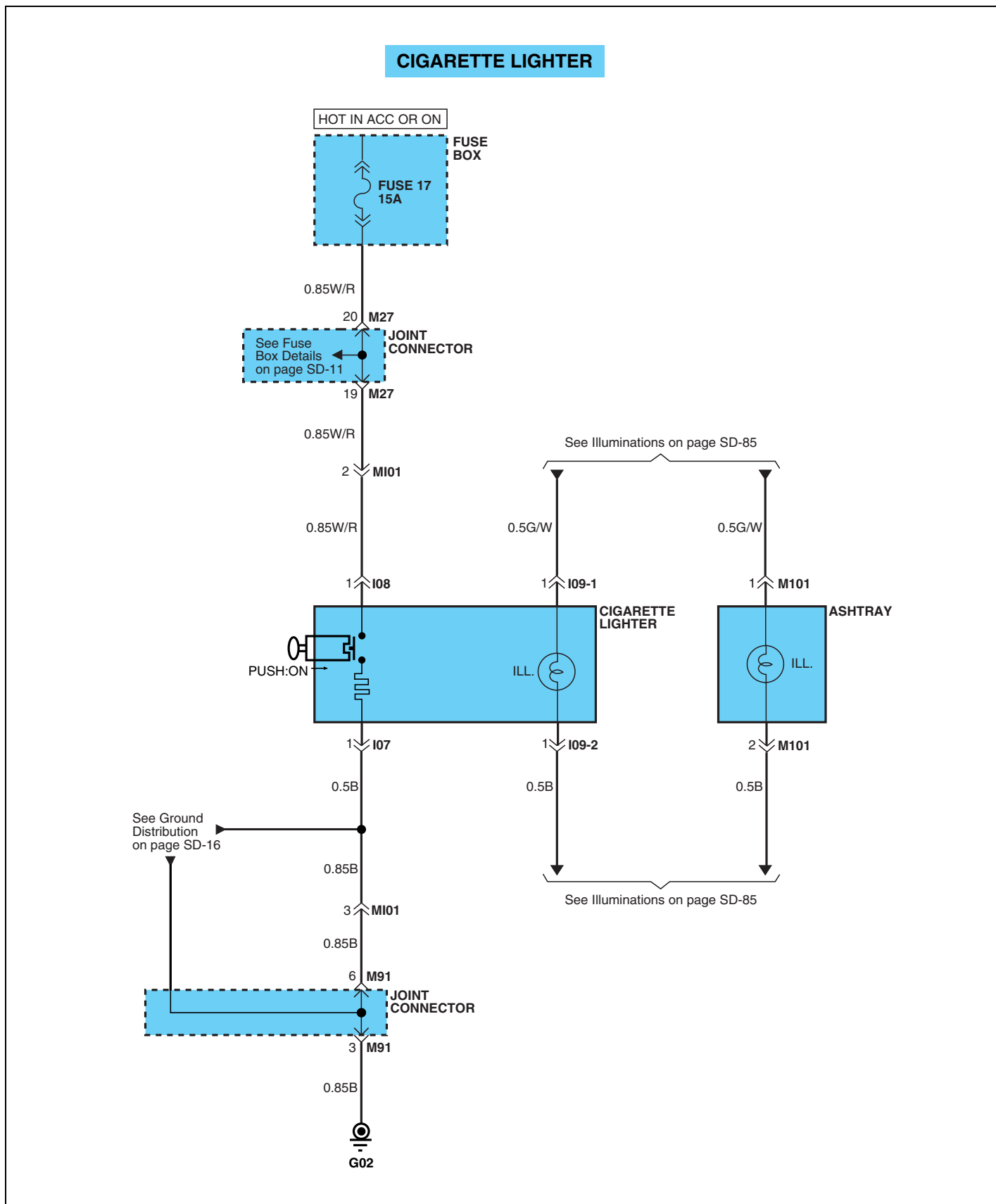

COMPONENT LOCATION INDEX

Components		Location reference-page
I01	Hazard switch	CL-15
I07	Cigarette lighter	CL-15
I08	Cigarette lighter	CL-15
I09-1	Cigarette lighter	CL-15
I09-2	Cigarette lighter	CL-15
M02	Tail lamp relay	CL- 2
M26	Joint connector	CL- 2
M27	Joint connector	CL- 2
M34	Joint connector	CL- 3
M38-1	Multifunction switch	CL- 3
M41-2,3	Instrument cluster	CL- 3
M90	Joint connector	CL- 4
M91	Joint connector	CL- 4
M101	Ashtray	CL- 5
R26	Roof clock	CL-17
Connectors		
MI01		CL- 6
MR02		CL- 6
Grounds		
G02		CL-19
G03		CL-19

ETACS (ELECTRONIC TIME AND ALARM CONTROL SYSTEM)

E5E8EDEA

ETACS (ELECTRONIC TIME AND ALARM CONTROL SYSTEM) (1)

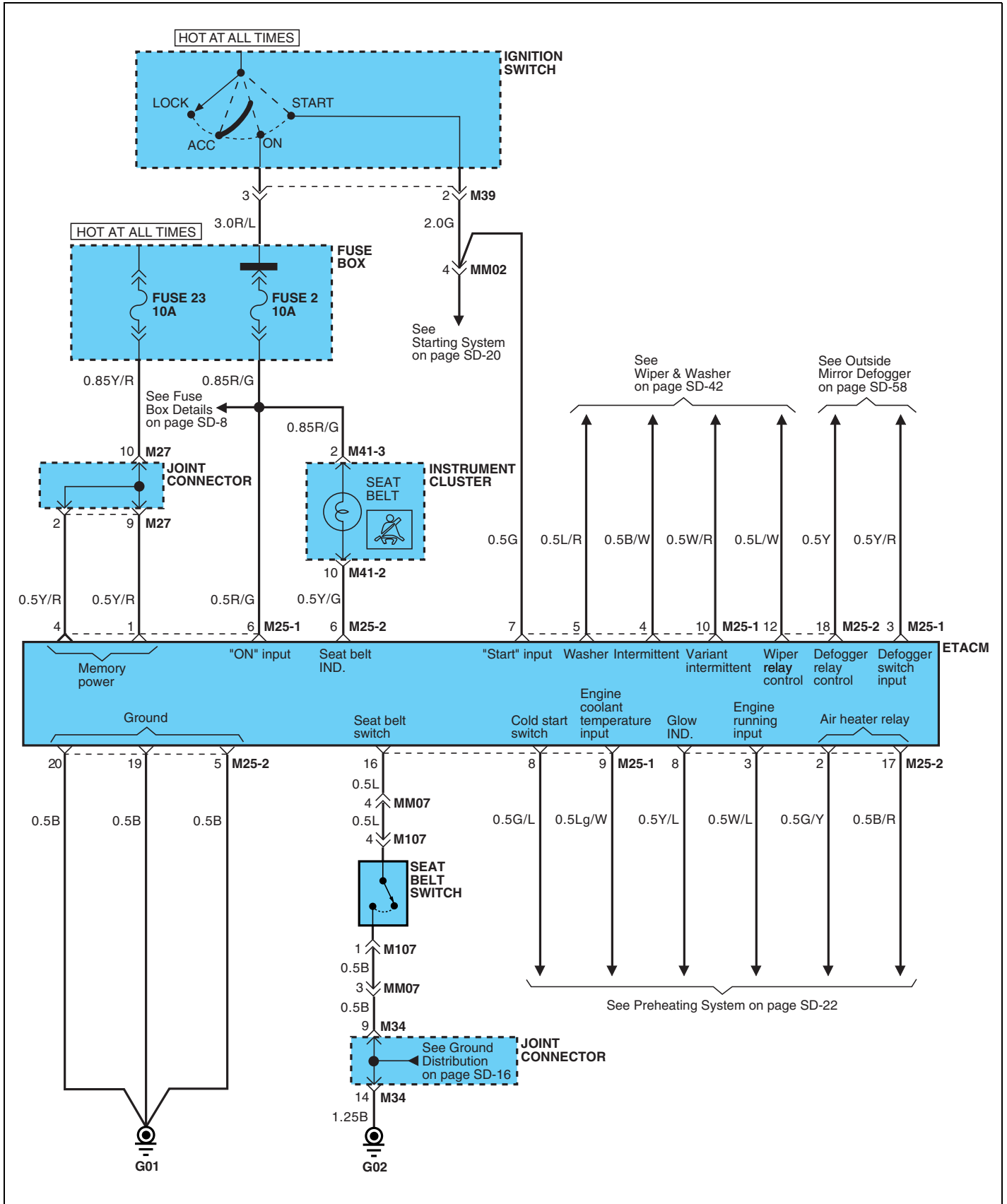

COMPONENT LOCATION INDEX

Components		Location reference-page
M25-1	ETACM	CL- 2
M25-2	ETACM	CL- 2
M27	Joint connector	CL- 2
M34	Joint connector	CL- 3
M39	Ignition switch	CL- 3
M41-2	Instrument cluster	CL- 3
M41-3	Instrument cluster	CL- 3
M107	Seat belt switch	CL-11
Connectors		
MM07		CL- 6
Grounds		
G01		CL-19
G02		CL-19

FRONT WIPER AND WASHER E90C382E

FRONT WIPER AND WASHER (1)

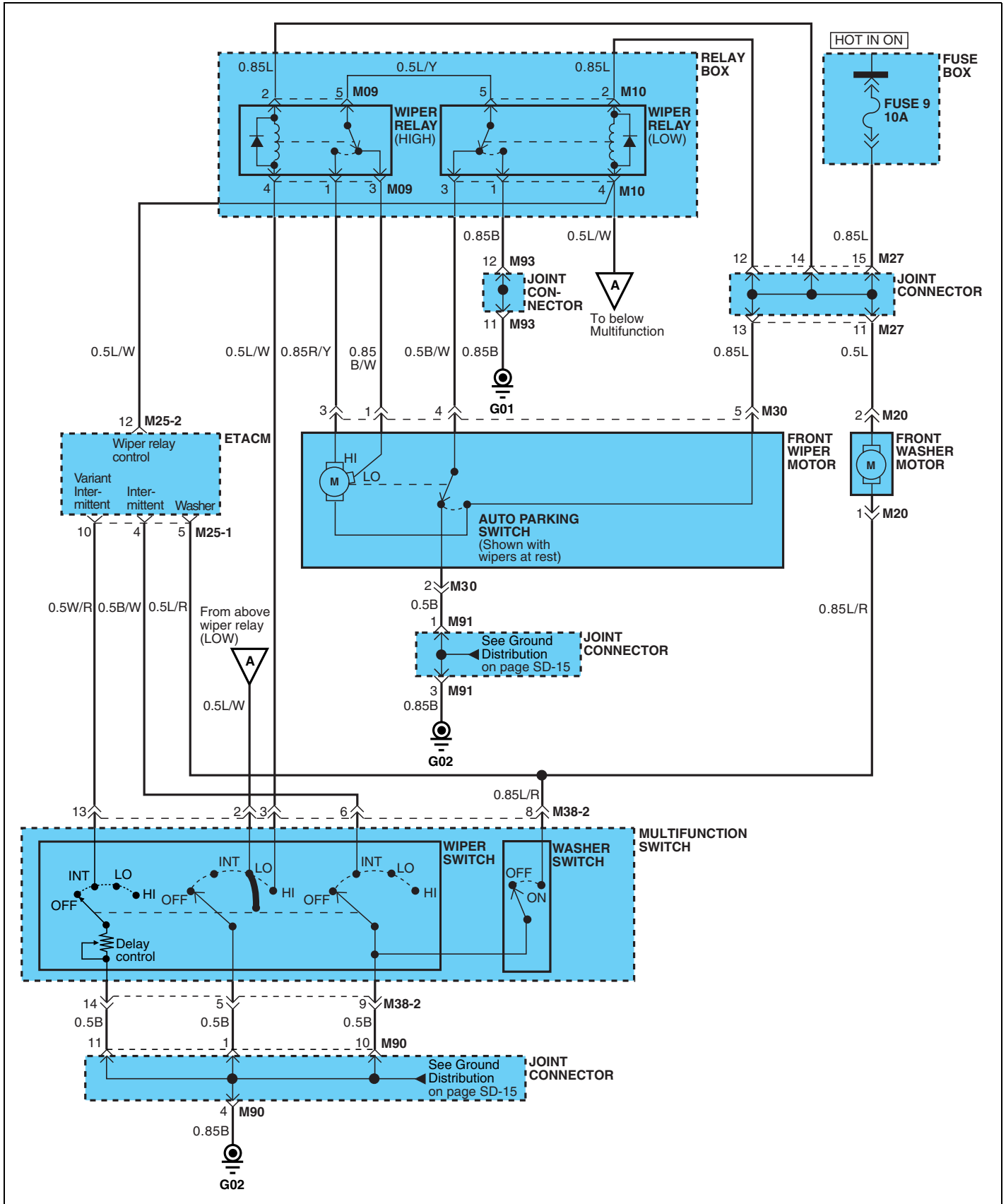

COMPONENT LOCATION INDEX

Components		Location reference-page
M09	Wiper relay (HIGH)	CL- 2
M10	Wiper relay (LOW)	CL- 2
M20	Front washer motor	CL- 2
M25-1	ETACM	CL- 2
M25-2	ETACM	CL- 2
M27	Joint connector	CL- 2
M30	Front wiper motor	CL- 2
M34	Joint connector	CL- 3
M38-2	Multifunction switch	CL- 3
M90	Joint connector	CL- 4
M91	Joint connector	CL- 4
M93	Joint connector	CL- 4
Grounds		
G01		CL-19
G02		CL-19

REAR WIPER AND WASHER ECA23E45

REAR WIPER AND WASHER (1)

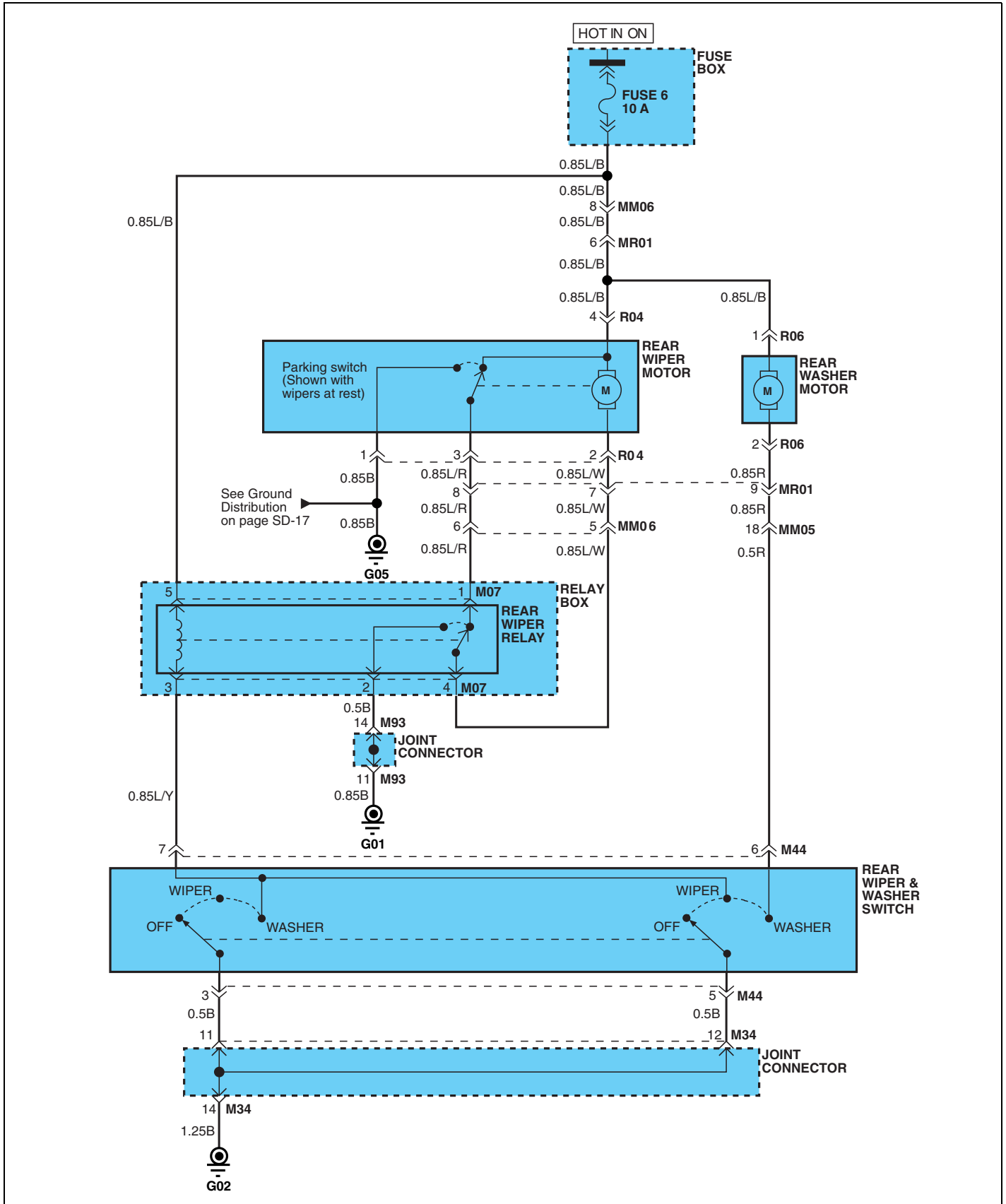

COMPONENT LOCATION INDEX

Components		Location reference-page
M07	Rear wiper relay	CL- 2
M34	Joint connector	CL- 3
M44	Rear wiper and washer switch	CL- 3
M93	Joint connector	CL- 4
R04	Rear wiper motor	CL-16
R06	Rear washer motor	CL-16
Connectors		
MM05		CL- 6
MM06		CL- 6
MR01		CL-12
Grounds		
G01		CL-19
G02		CL-19
G05		CL-19

SAFETY DOOR SYSTEM

E776E6A3

SAFETY DOOR SYSTEM (1)

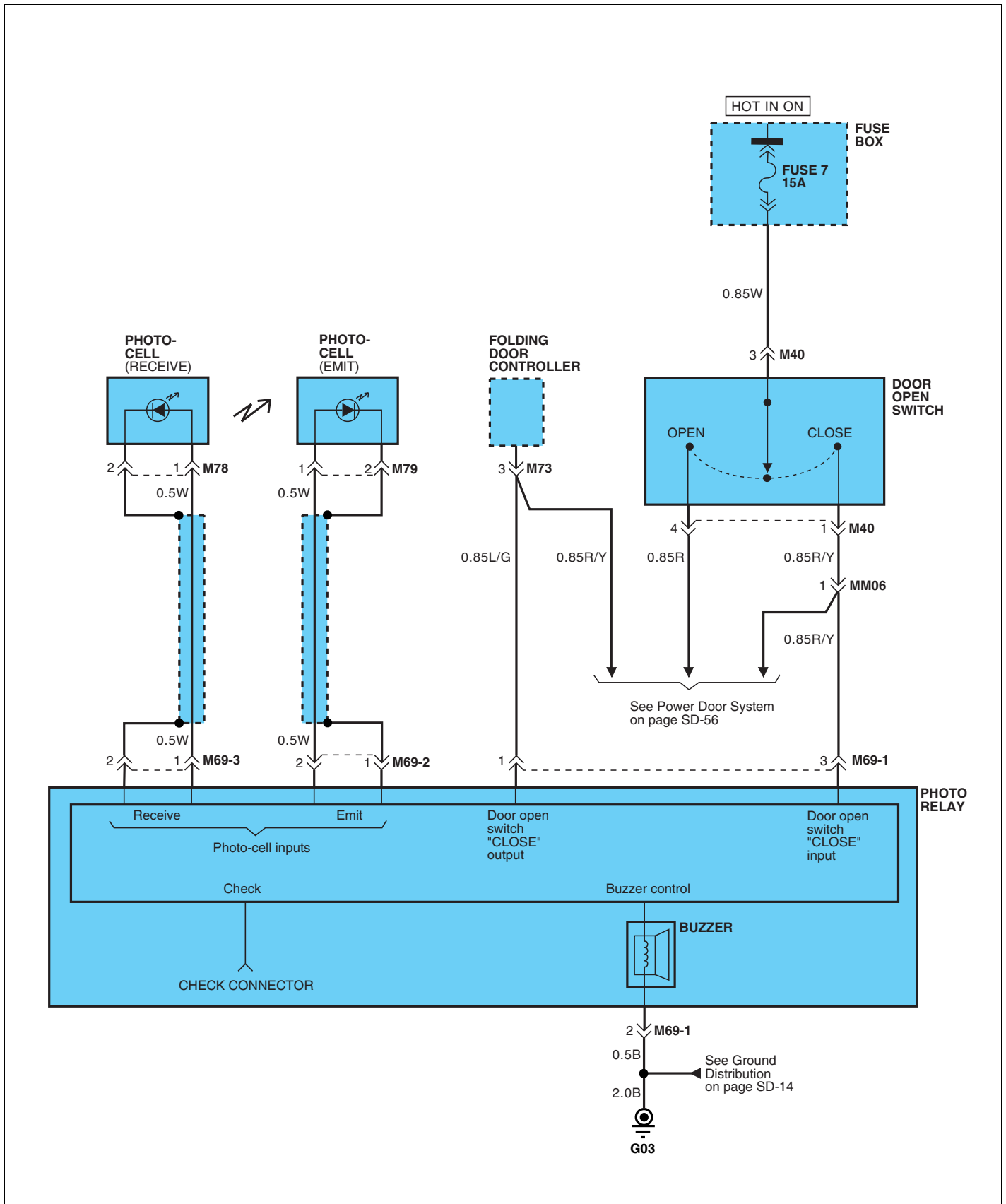

COMPONENT LOCATION INDEX

Components		Location reference-page
M40	Door open switch	CL- 3
M69-1	Photo relay	CL- 8
M69-2	Photo relay (EMIT)	CL- 8
M69-3	Photo relay (RECEIVE)	CL- 8
M73	Folding door controller	CL- 9
M78	Photo-cell (RECEIVE)	CL- 9
M79	Photo-cell (EMIT)	CL- 9
Connectors		
MM06		CL- 6
Grounds		
G03		CL-19

INDICATORS EE0CB7BB

INDICATORS (1)

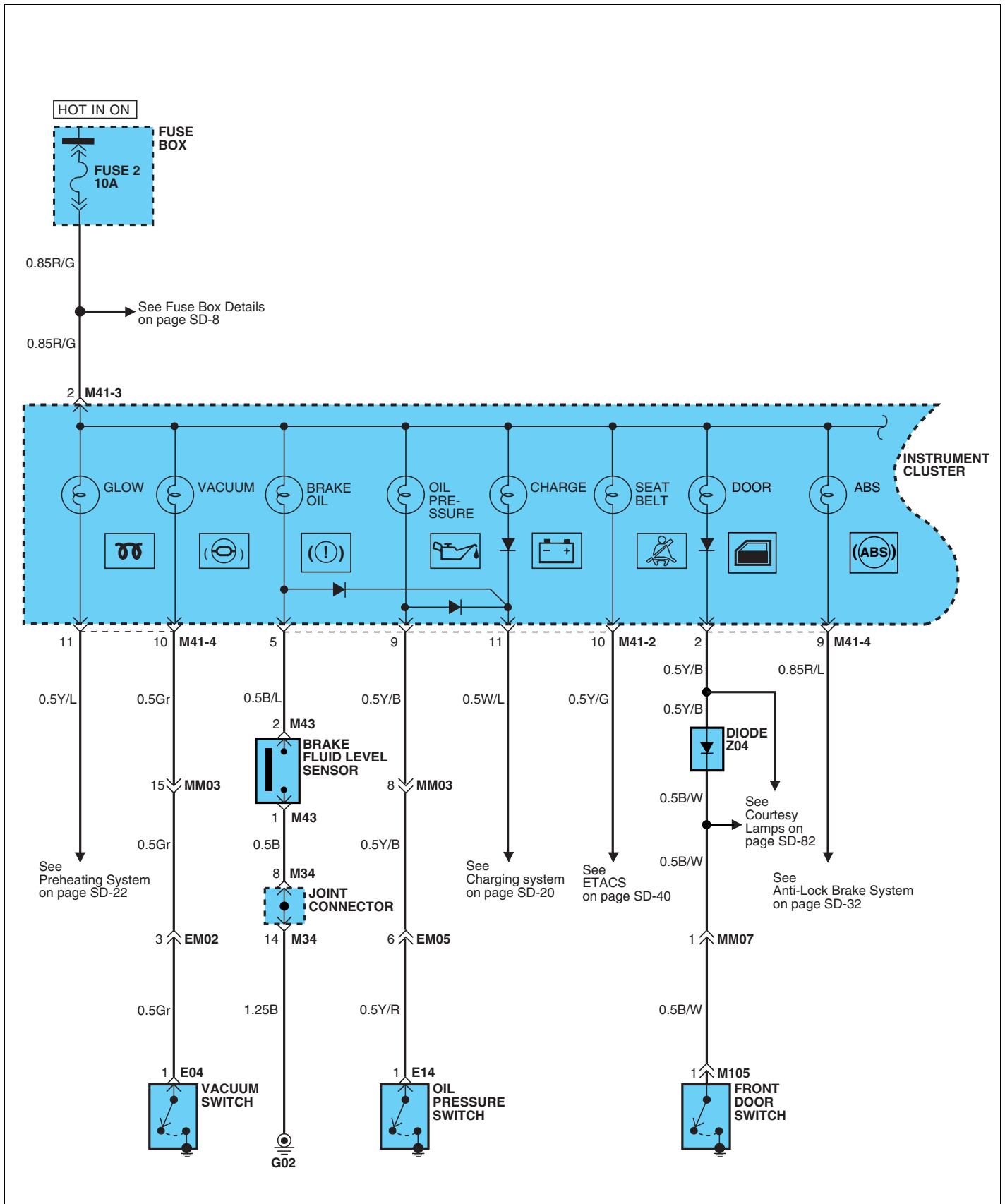

INDICATORS (2)

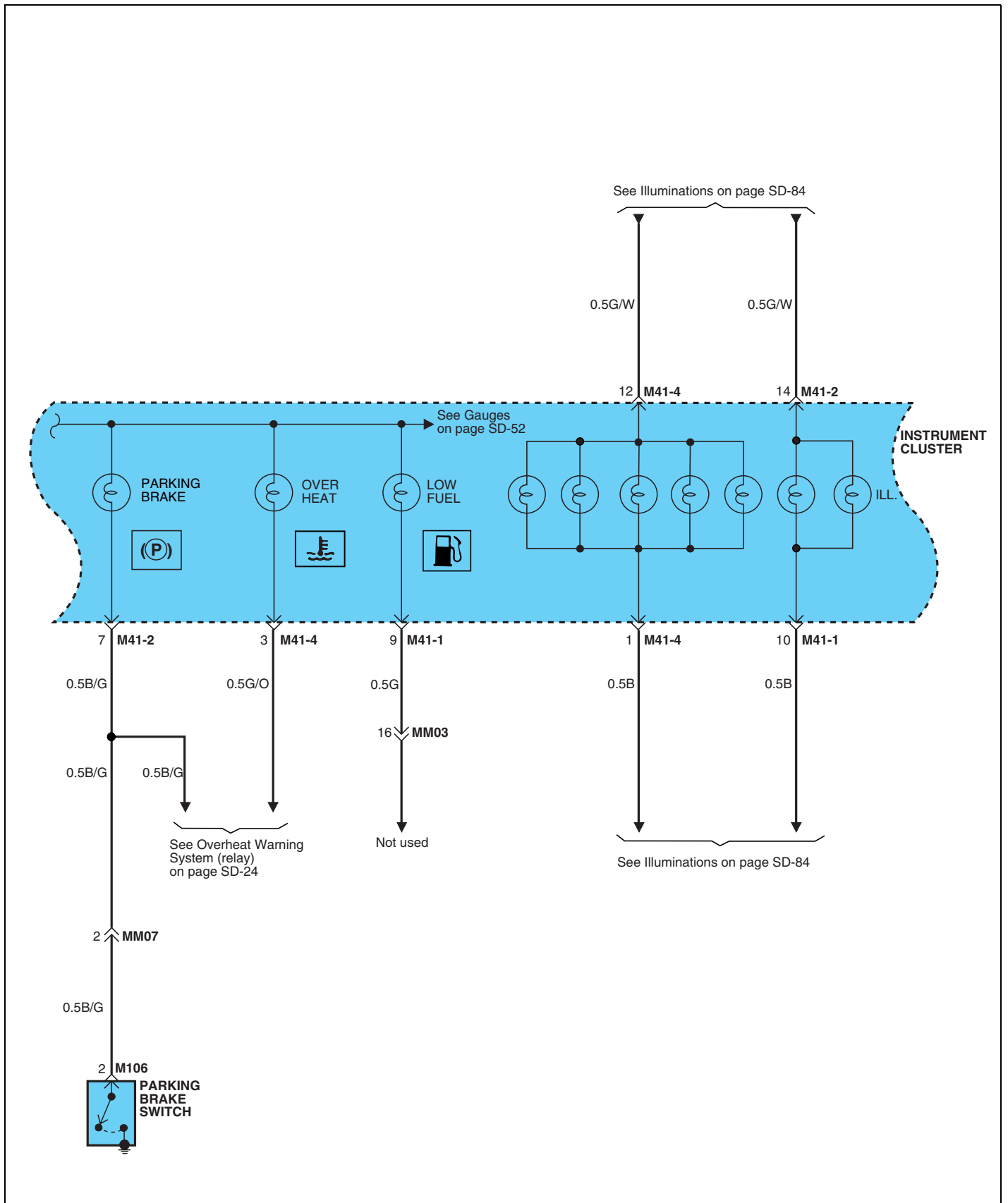

INDICATORS (3)

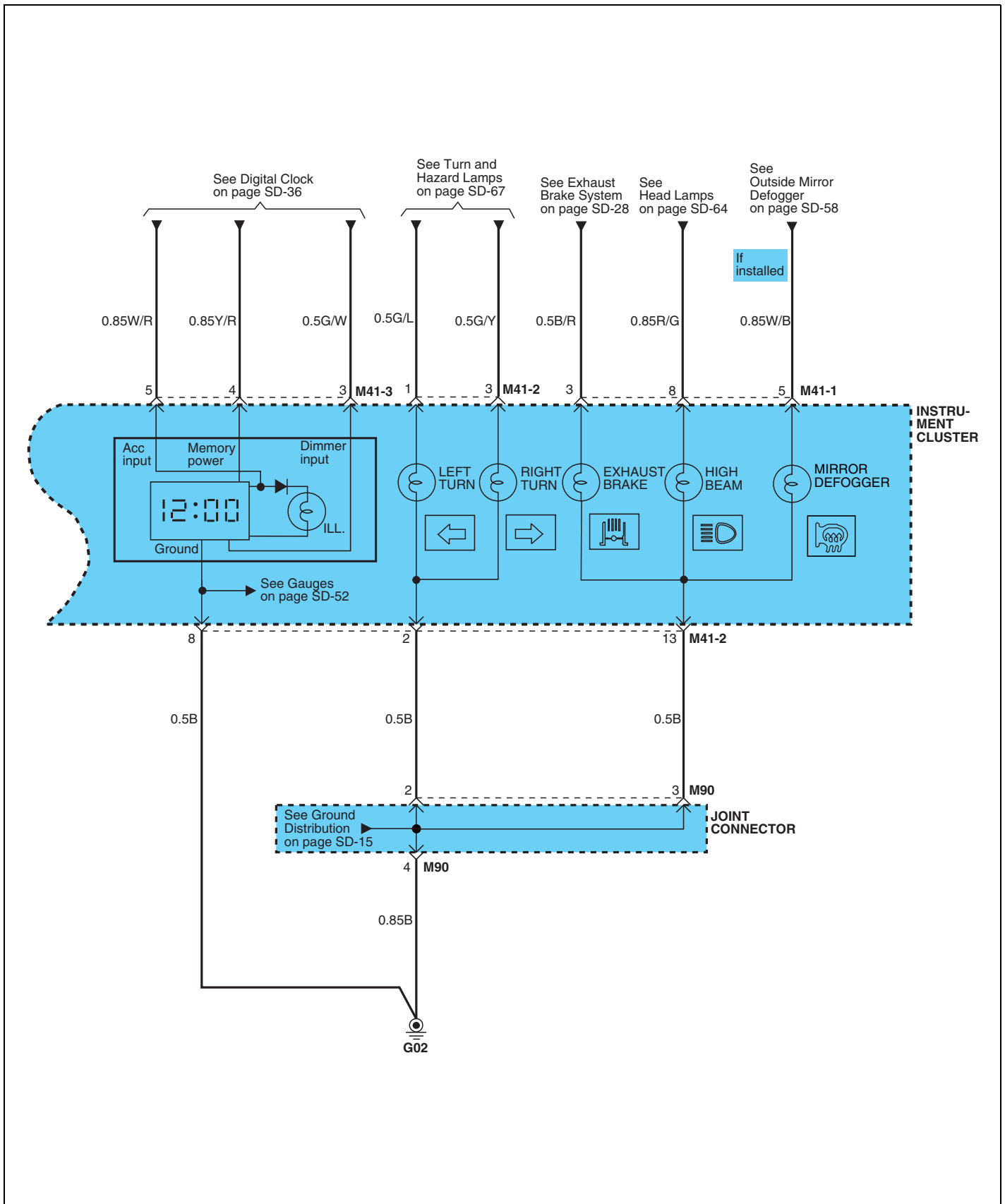

COMPONENT LOCATION INDEX

Components		Location reference - page
E04	Vacuum switch	CL-13
E14	Oil pressure switch	CL-13
M34	Joint connector	CL- 3
M41-1	Instrument cluster	CL- 3
M41-2	Instrument cluster	CL- 3
M41-3	Instrument cluster	CL- 3
M41-4	Instruemtn cluster	CL- 3
M43	Brake fluid level sensor	CL- 3
M90	Joint connector	CL- 4
M105	Front door switch	CL-11
M106	Parking brake switch	CL-11
Connectors		
EM05		CL-12
MM03		CL- 6
MM07		CL- 6
Grounds		
G02		CL-19
Diodes		
Z04		CL-20

GAUGES

E38BEB8B

GAUGES (1)

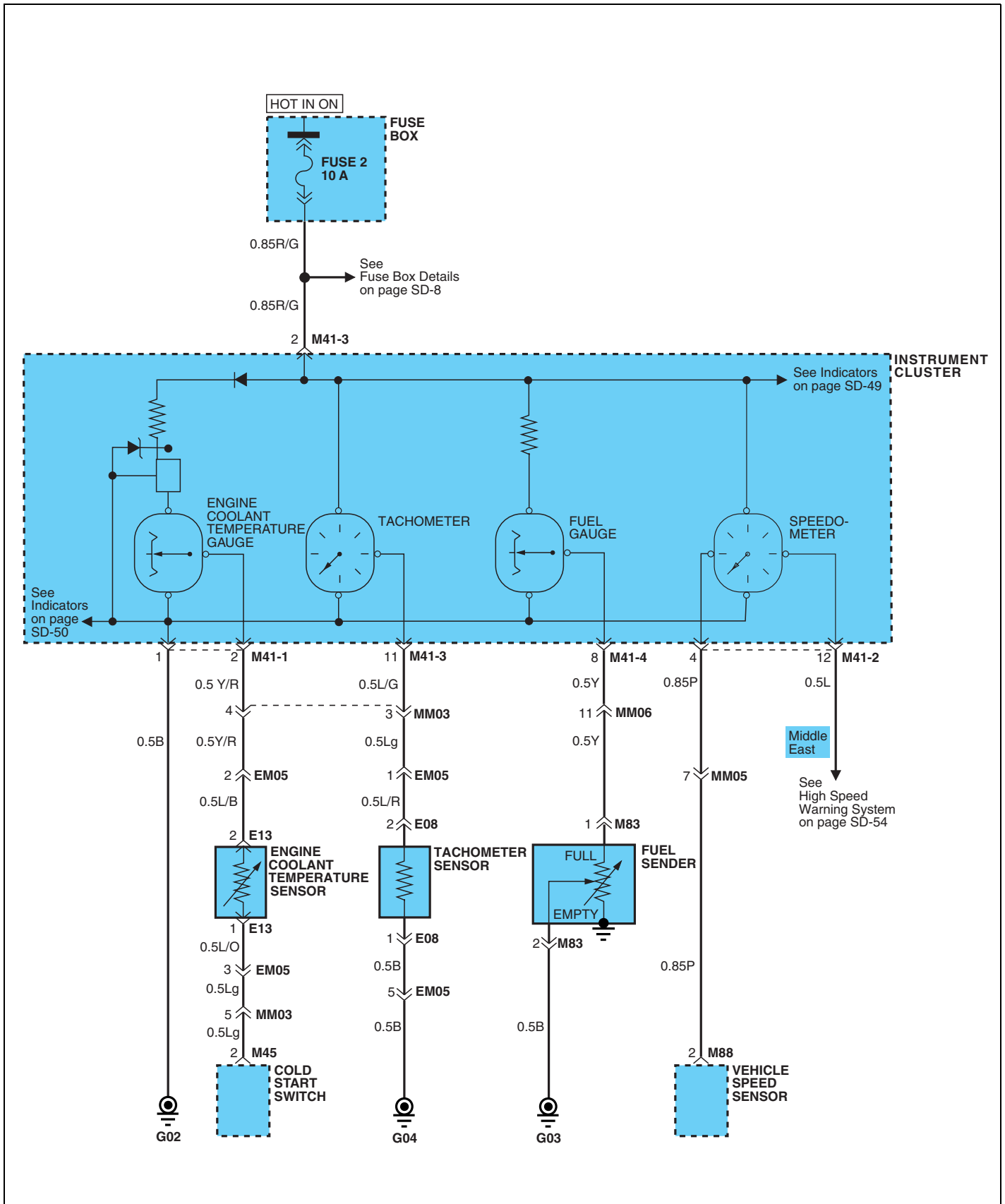

COMPONENT LOCATION INDEX

Components		Location reference-page
E08	Tachometer sensor	CL-13
E13	Engine coolant temperature sensor	CL-13
M41-1	Instrument cluster	CL- 3
M41-2	Instrument cluster	CL- 3
M41-3	Instrument cluster	CL- 3
M41-4	Instrument cluster	CL- 3
M45	Cold start switch	CL- 3
M83	Fuel sender	CL-10
M88	Vehicle speed sensor	CL-10
Connectors		
EM03		CL-11
EM05		CL-12
MM03		CL- 6
MM06		CL- 6
Grounds		
G02		
G03		CL-19
		CL-19

HIGH SPEED WARNING SYSTEM

EA3A3C45

HIGH SPEED WARNING SYSTEM (1)

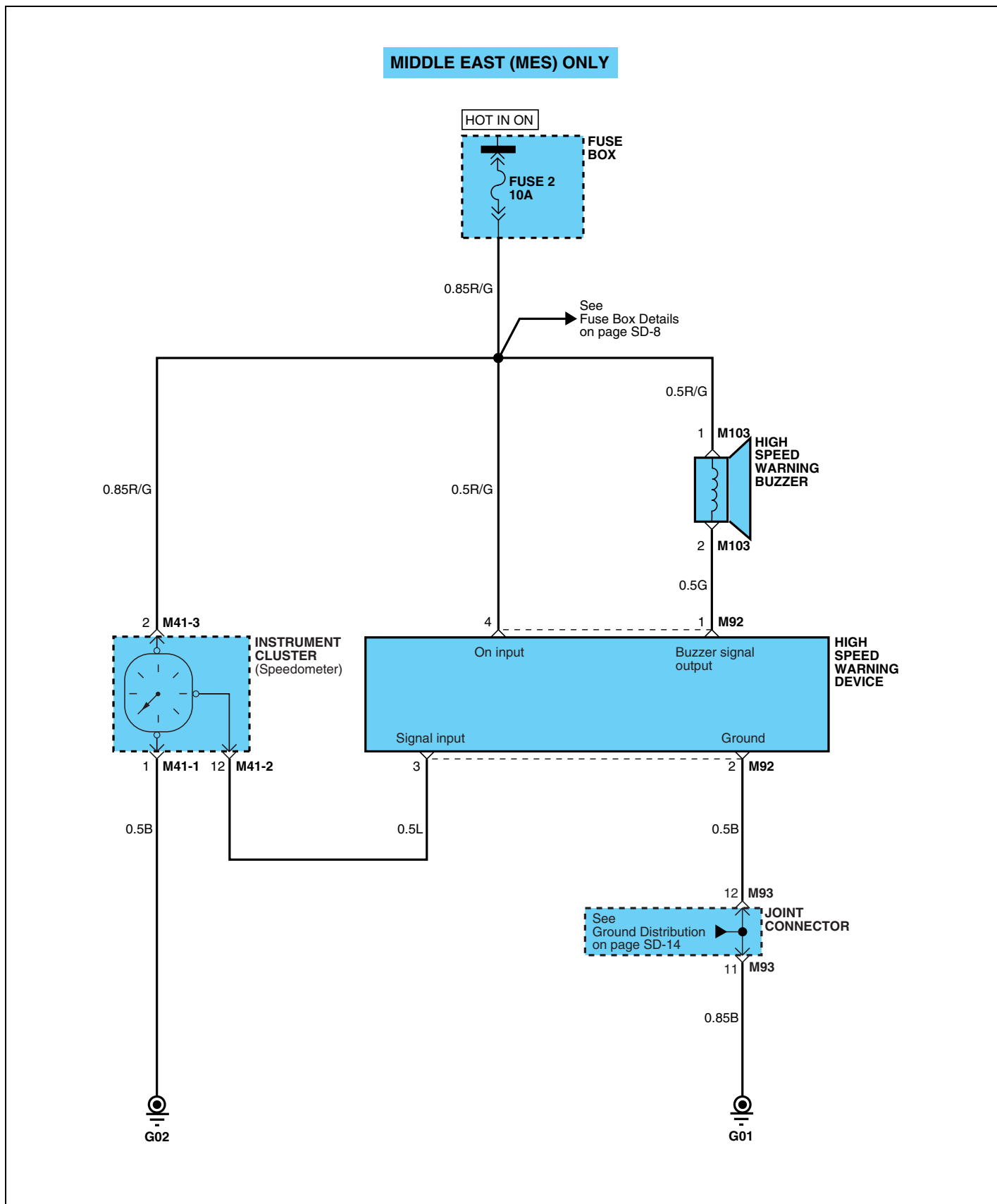

COMPONENT LOCATION INDEX

Components		Location reference-page
M25-1	ETACM	CL- 2
M41-2,3	Instrument cluster	CL- 3
M93	Joint connector	CL- 4
Grounds		
G01		CL-19

POWER DOOR SYSTEM

E4DE1F7C

POWER DOOR SYSTEM (1)

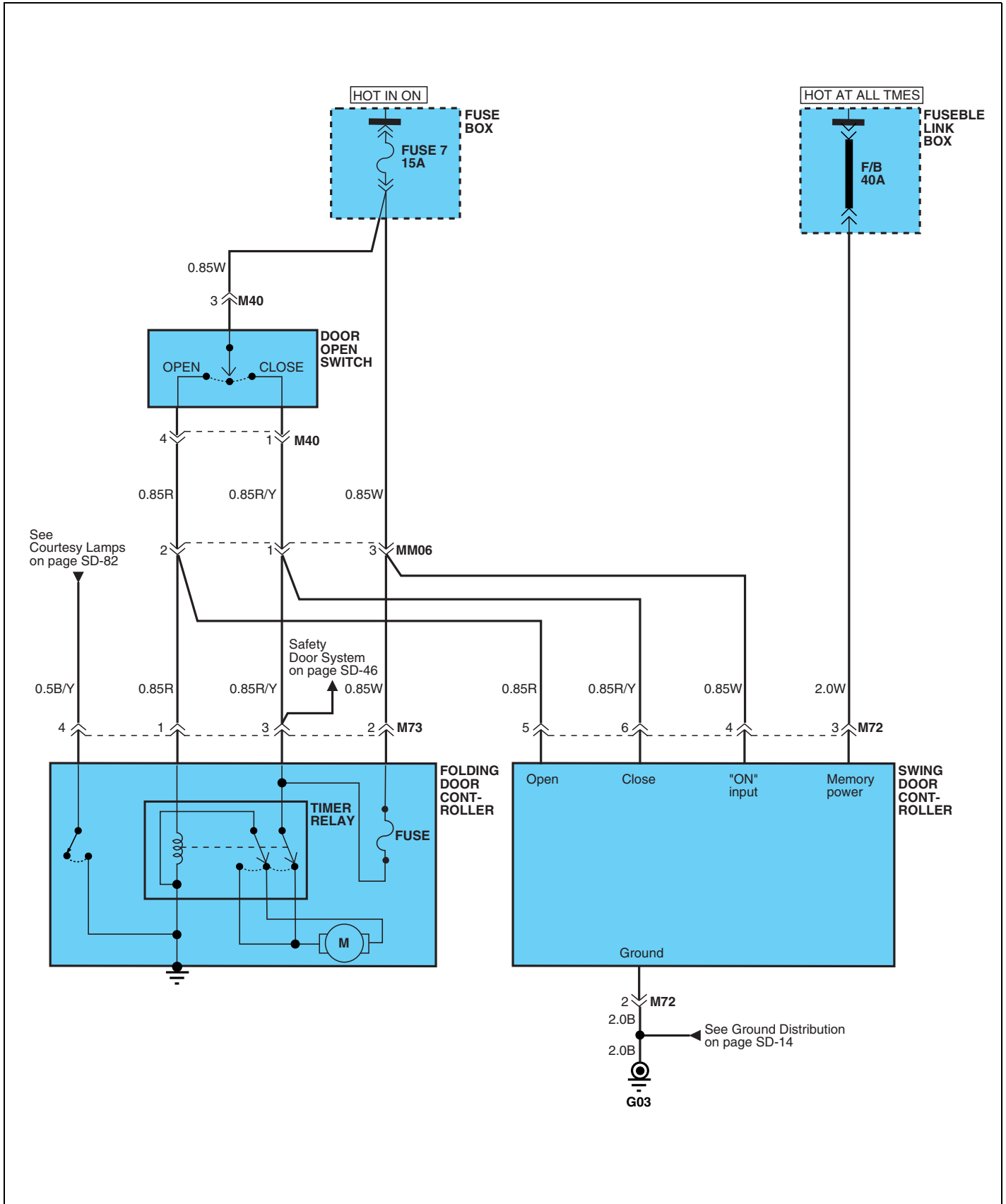

COMPONENT LOCATION INDEX

Components		Location reference-page
M40	Door open switch	CL- 3
M72	Swing door controller	CL- 8
M73	Folding door controller	CL- 9
Connectors		
MM02		CL- 6
MM06		CL- 6
Grounds		
G03		CL-19

OUTSIDE MIRROR DEFOGGER

EAAF070B

OUTSIDE MIRROR DEFOGGER (1)

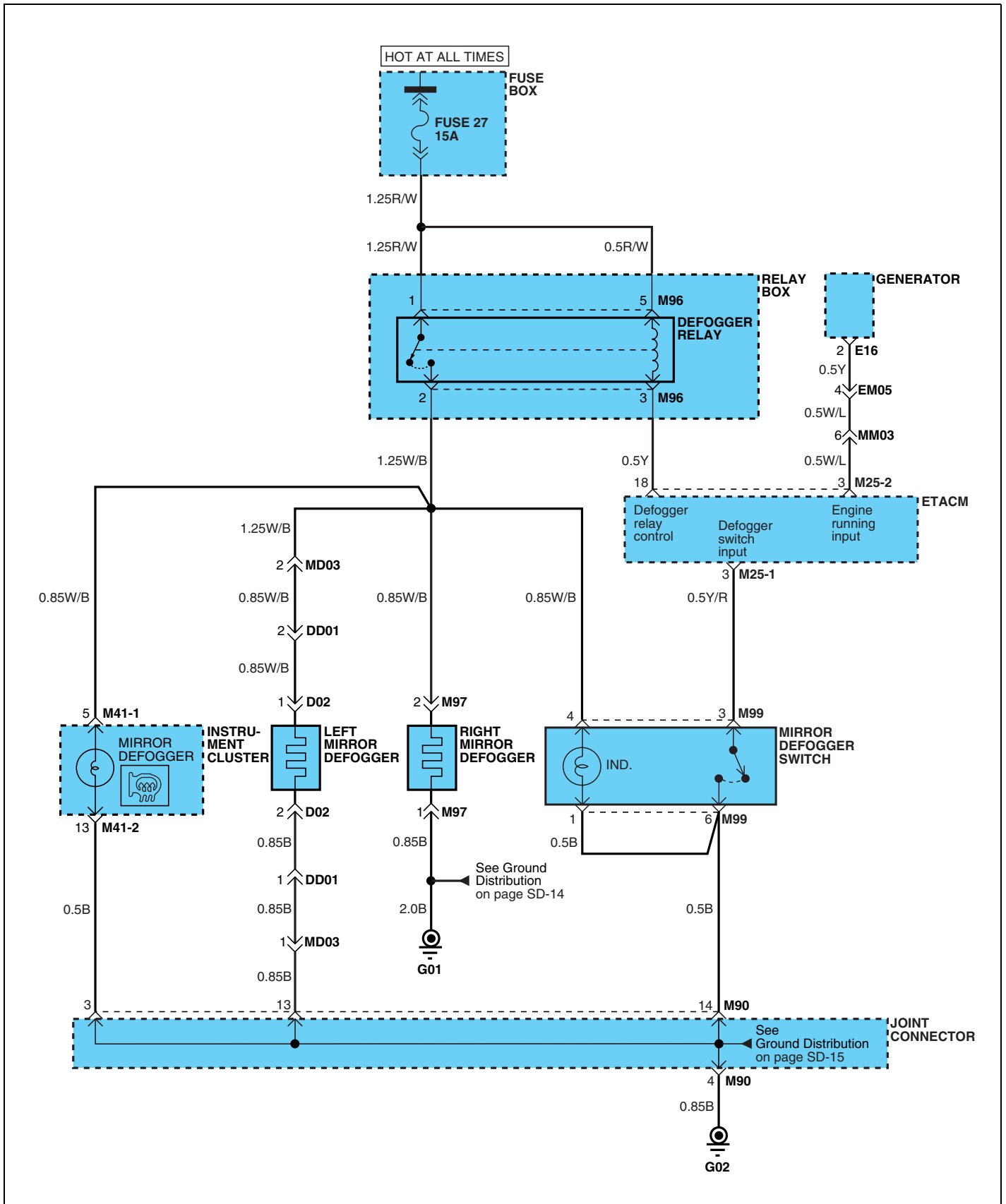

COMPONENT LOCATION INDEX

Components		Location reference-page
E16	Generator	CL-13
M25-1	ETACM	CL- 2
M25-2	ETACM	CL- 2
M41-1	Instrument cluster	CL- 3
M41-2	Instrument cluster	CL- 3
M90	Joint connector	CL- 4
M96	Defogger relay	CL- 5
M97	Right mirror defogger	CL- 5
M99	Mirror defogger switch	CL- 5
Connectors		
EM05		CL-12
MD03		CL- 5
MM03		CL- 6
Grounds		
G02		CL-19

AUDIO & HORN SYSTEM

E47EB6AB

AUDIO & HORN SYSTEM (1)

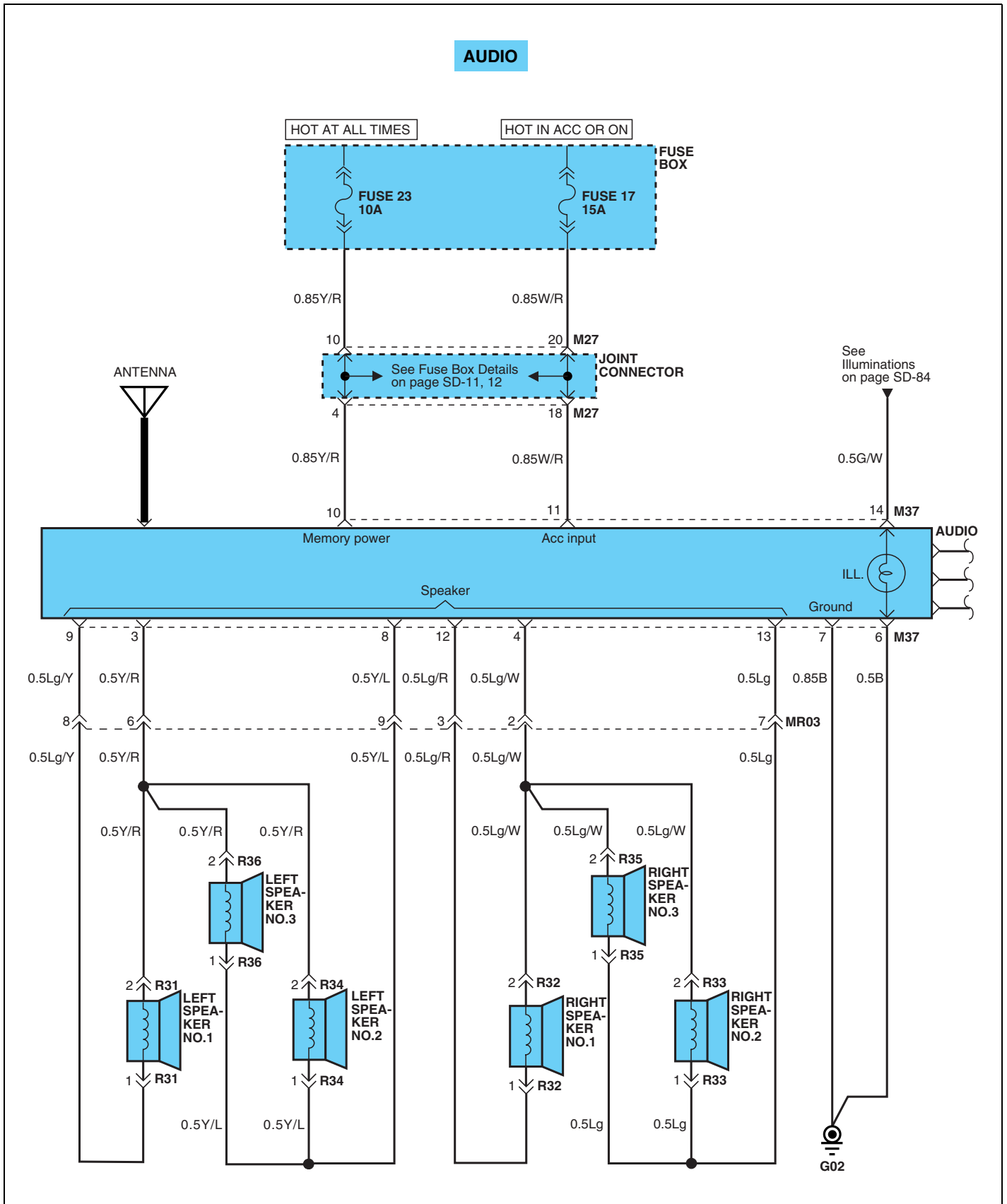

AUDIO & HORN SYSTEM (2)

AUDIO

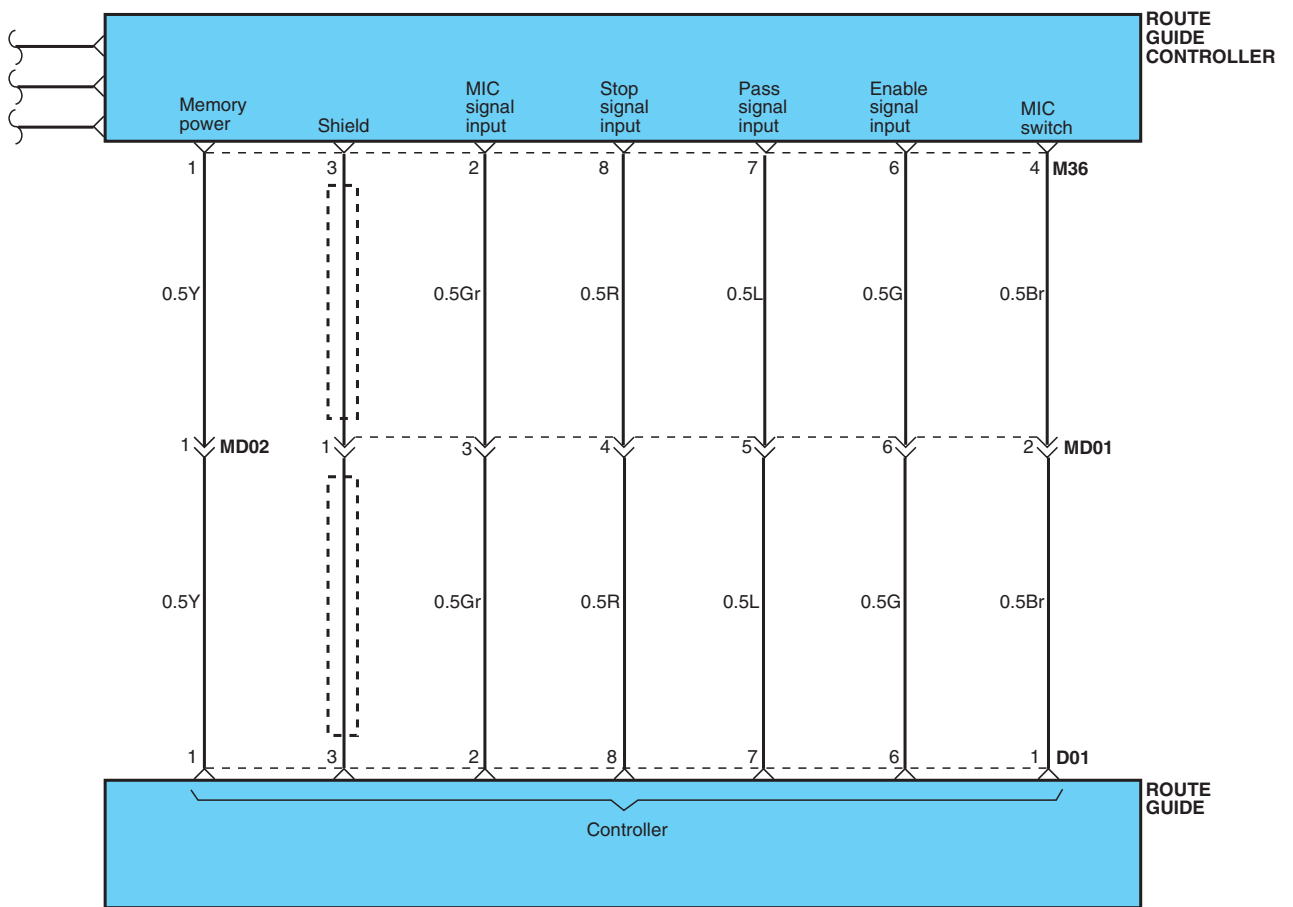

AUDIO & HORN SYSTEM (3)

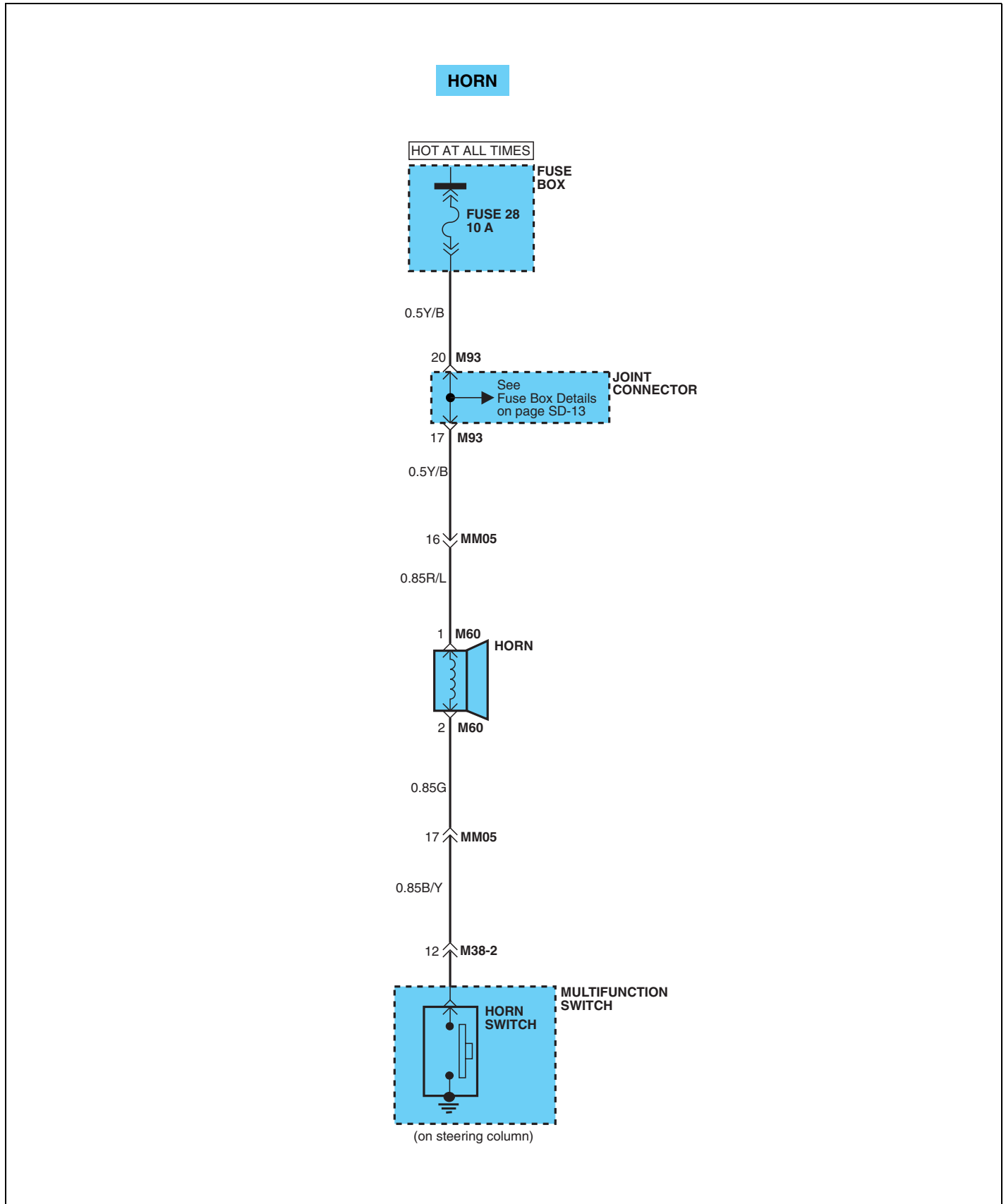

COMPONENT LOCATION INDEX

Components		Location reference-page
D01	Route guide	CL-15
M27	Joint connector	CL- 2
M36	Route guide controller	CL- 3
M37	Audio	CL- 3
M38-2	Multifunction switch	CL- 3
M60	Horn	CL- 8
R31	Left speaker No.1	CL-17
R32	Right speaker No.1	CL-17
R33	Right speaker No.2	CL-18
R34	Left speaker No.2	CL-18
R35	Right speaker No.3	CL-18
R36	Left speaker No.3	CL-18
Connectors		
MD01		CL- 5
MM05		CL- 6
MR03		CL- 6
Grounds		
G02		CL-19

HEAD LAMPS

KF8BB0A9

HEAD LAMPS (1)

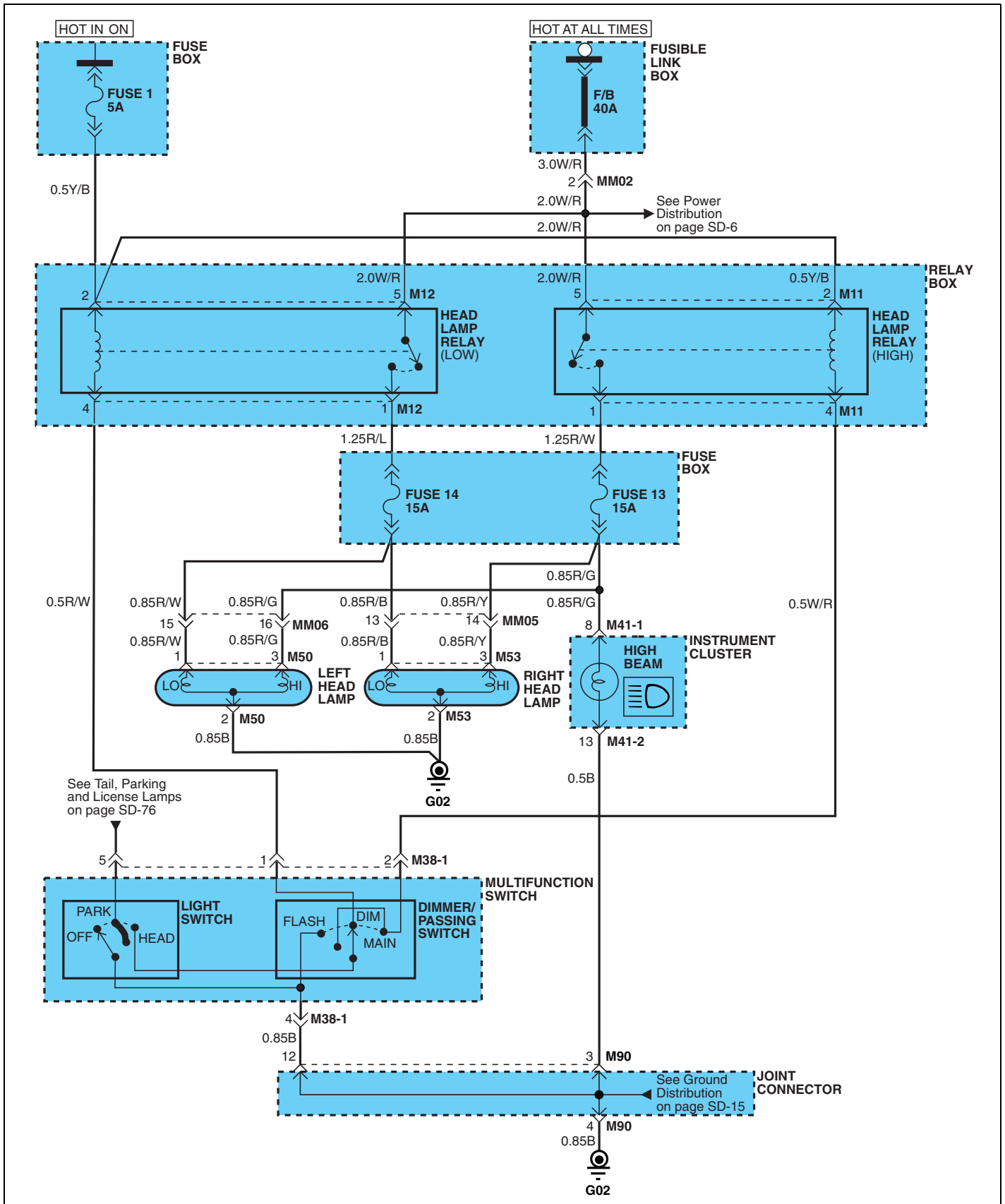

COMPONENT LOCATION INDEX

Components		Location reference - page
M11	Head lamp relay (HIGH)	CL- 2
M12	Head lamp relay (LOW)	CL- 2
M38-1	Multifunction switch	CL- 3
M41-1	Instrument cluster	CL- 3
M41-2	Instrument cluster	CL- 3
M50	Left head lamp	CL- 7
M53	Right head lamp	CL- 7
M90	Joint connector	CL- 4
Connectors		
MM02		CL- 6
MM05		CL- 6
MM06		CL- 6
Grounds		
G02		CL-19
M04		CL-19

TURN, HAZARD LAMPS & BACK-UP LAMPS

EDCC56BF

TURN, HAZARD LAMPS & BACK-UP LAMPS (1)

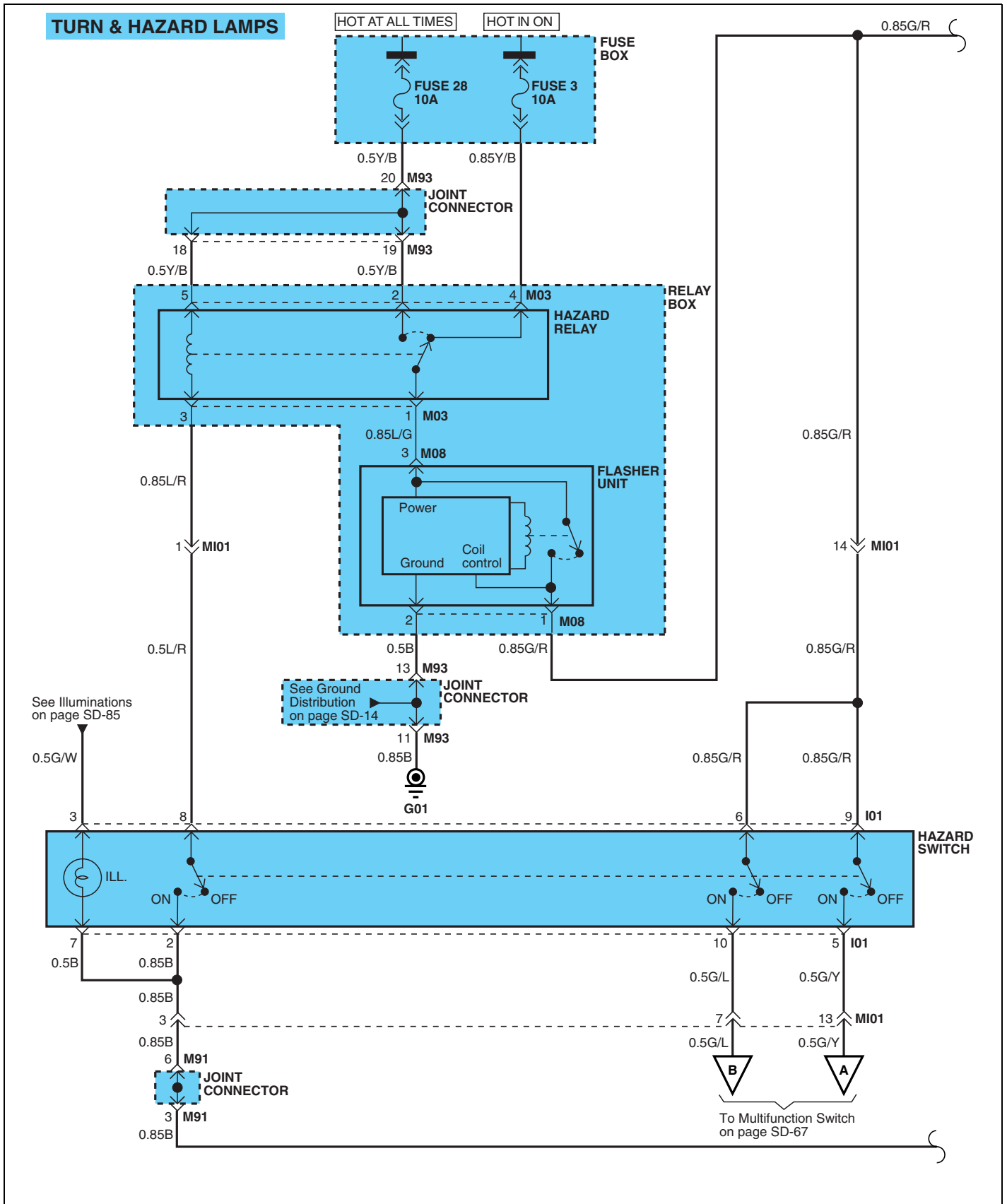

TURN, HAZARD LAMPS & BACK-UP LAMPS (2)

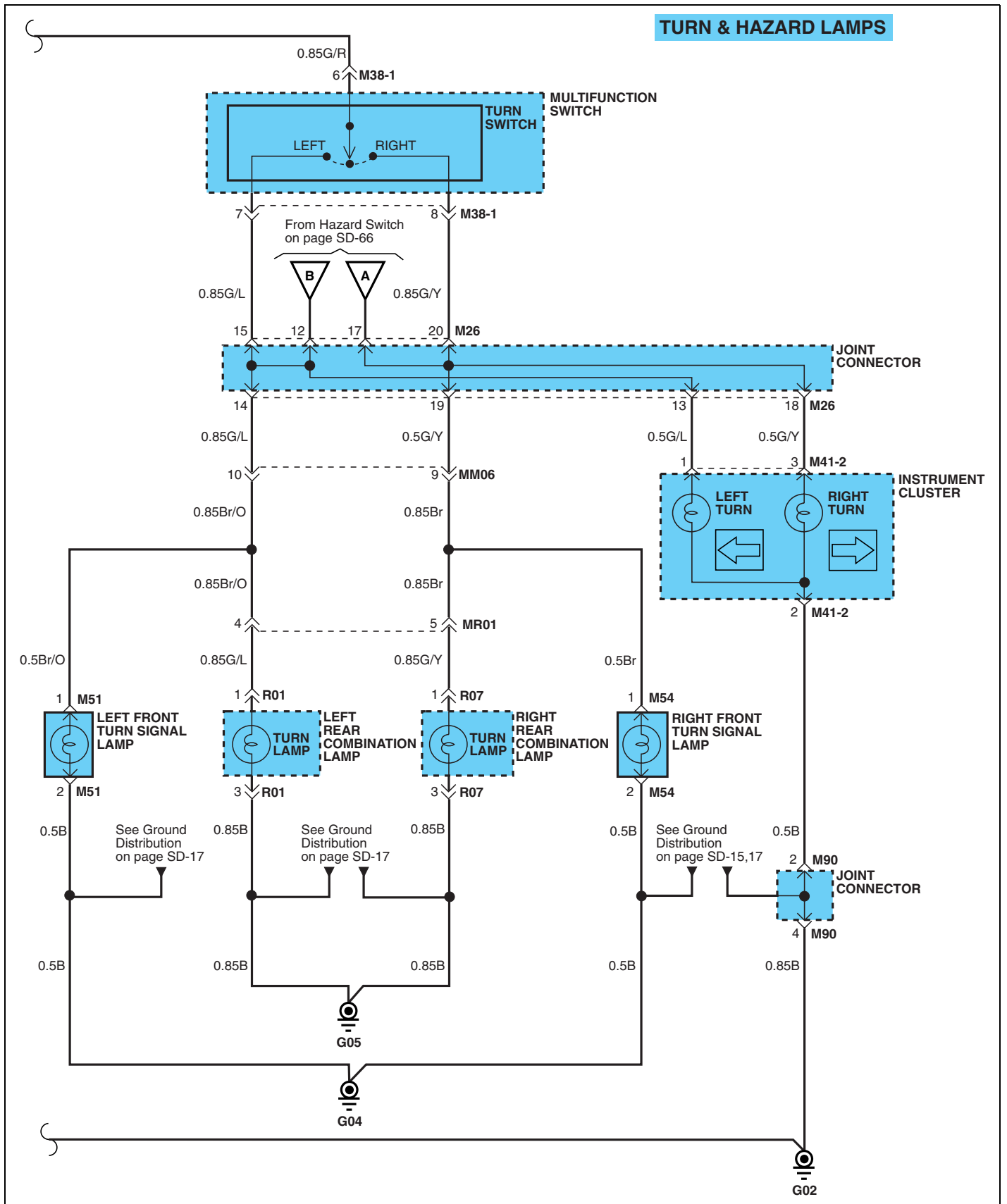

TURN, HAZARD LAMPS & BACK-UP LAMPS (3)

BACK-UP LAMPS

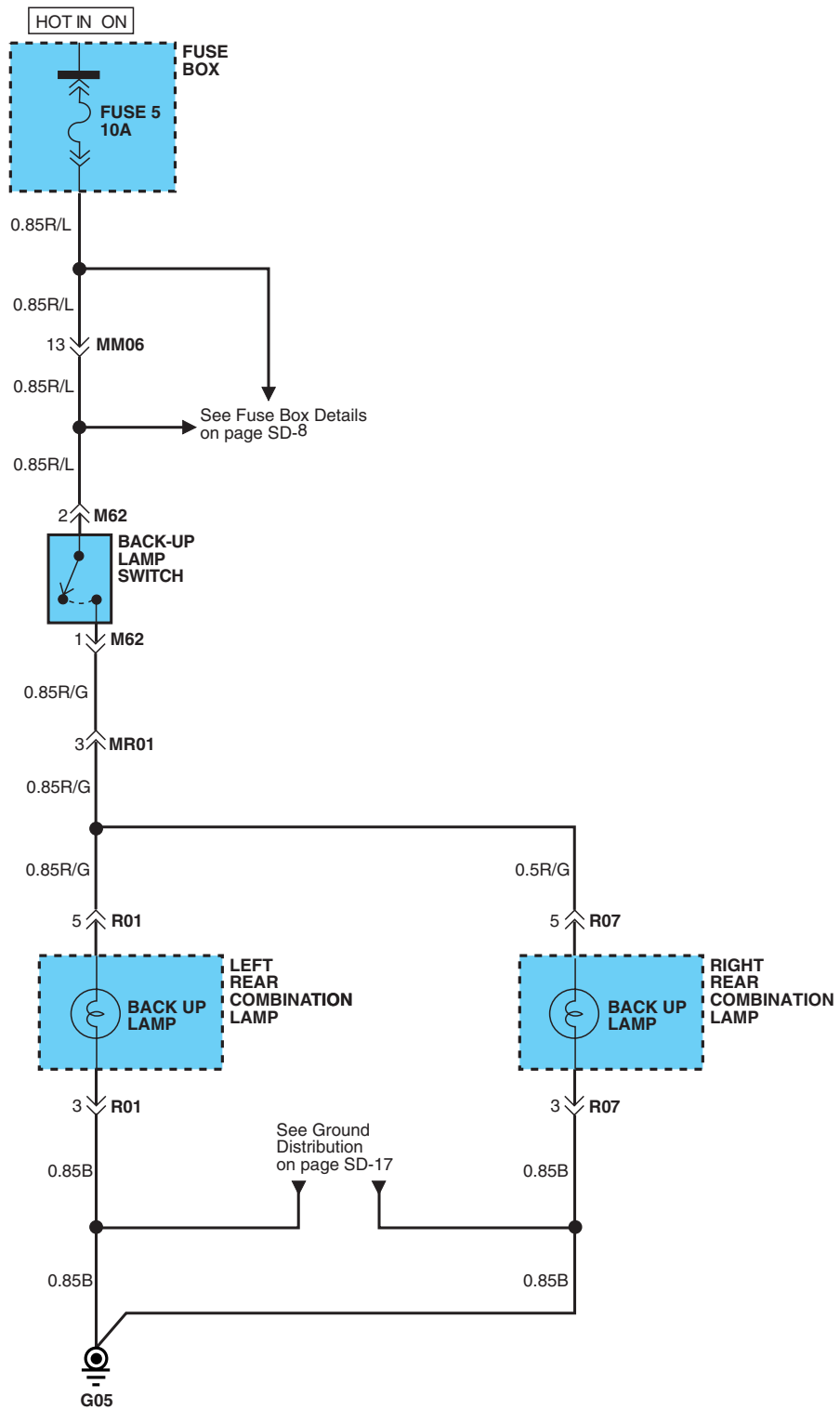

COMPONENT LOCATION INDEX

Components		Location reference-page
I01	Hazard switch	CL-15
M03	Hazard relay	CL- 2
M08	Flasher unit	CL- 2
M26	Joint connector	CL- 2
M38-1	Multifunction switch	CL- 3
M41-2	Instrument cluster	CL- 3
M51	Left front turn signal lamp	CL- 7
M54	Right front turn signal lamp	CL- 7
M62	Back-up lamp switch	CL- 8
M90	Joint connector	CL- 4
M91	Joint connector	CL- 4
M93	Joint connector	CL- 4
R01	Left rear combination lamp	CL-16
R07	Right rear combination lamp	CL-16
Connectors		
MI01		CL- 6
MM06		CL- 6
MR01		CL-12
Grounds		
G01		CL-19
G02		CL-19
G04		CL-19
G05		CL-19

FRONT FOG LAMPS

E1B4D9F6

FRONT FOG LAMPS (1)

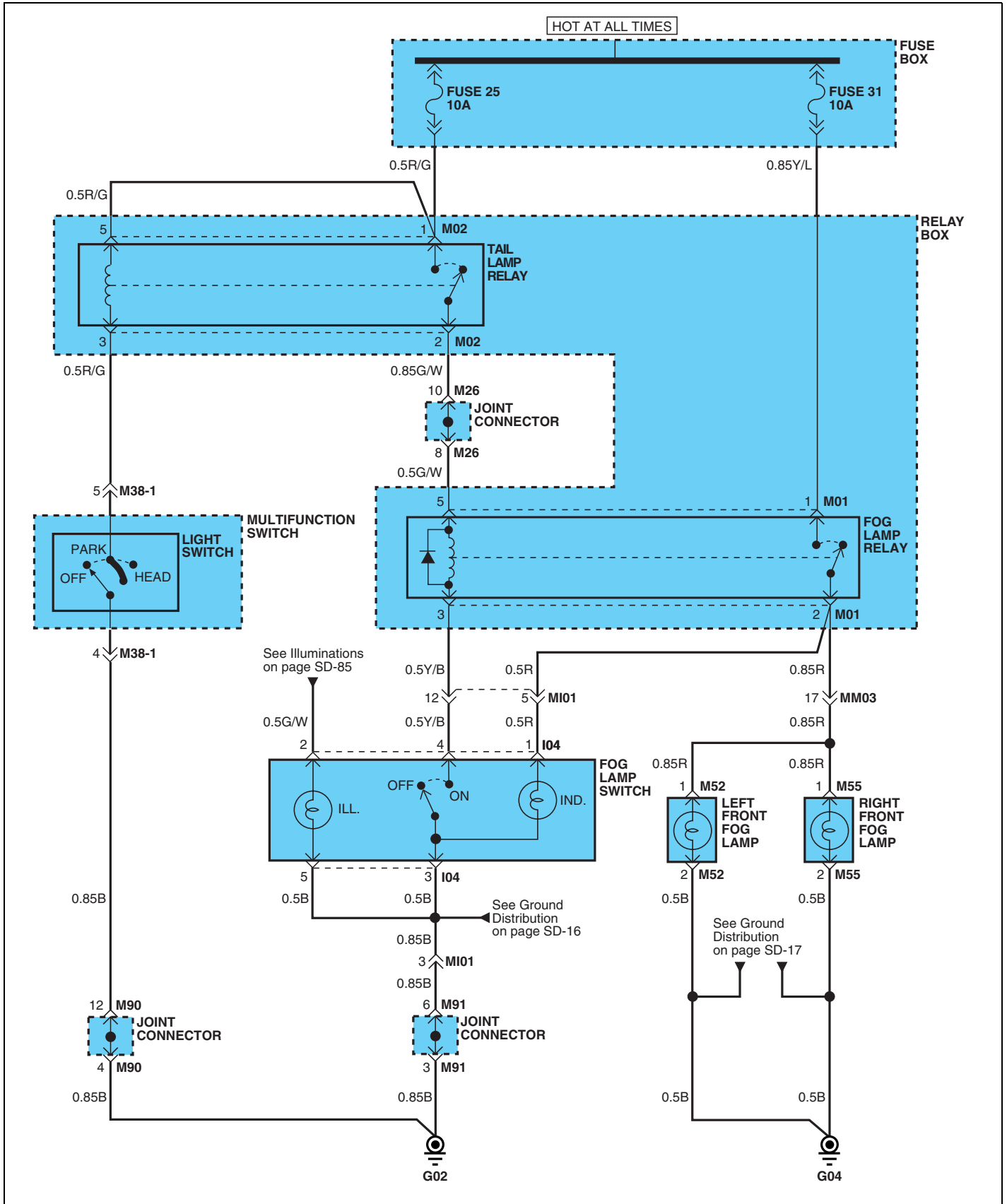

COMPONENT LOCATION INDEX

Components		Location reference-page
I04	Front fog lamp switch	CL-15
M01	Fog lamp relay	CL- 2
M02	Tail lamp relay	CL- 2
M26	Joint connector	CL- 2
M38-1	Multifunction switch	CL- 3
M52	Left front fog lamp	CL- 7
M55	Right front fog lamp	CL- 7
M90	Joint connector	CL- 4
M91	Joint connector	CL- 4
Connectors		
MI01		CL- 6
MM03		CL- 6
Grounds		
G02		CL-19
G04		CL-19

REAR FOG LAMPS

EF32BAA3

REAR FOG LAMPS (1)

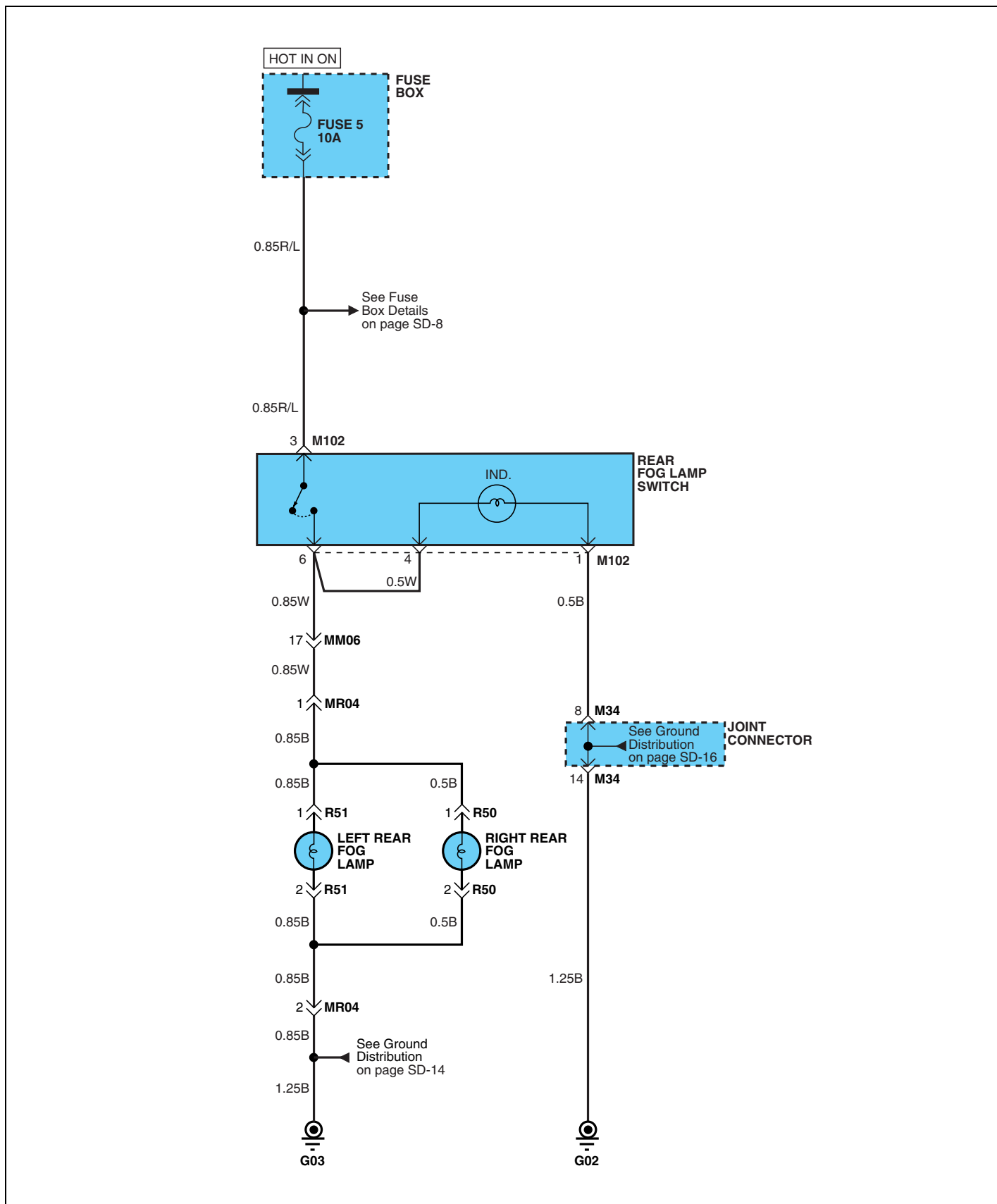

COMPONENT LOCATION INDEX

Components		Location reference-page
M34	Joint connector	CL- 3
M102	Rear fog lamp switch	CL- 5
Grounds		
G02		CL-19
G03		CL-19

ROOM LAMPS ECD2C3A1

ROOM LAMPS (1)

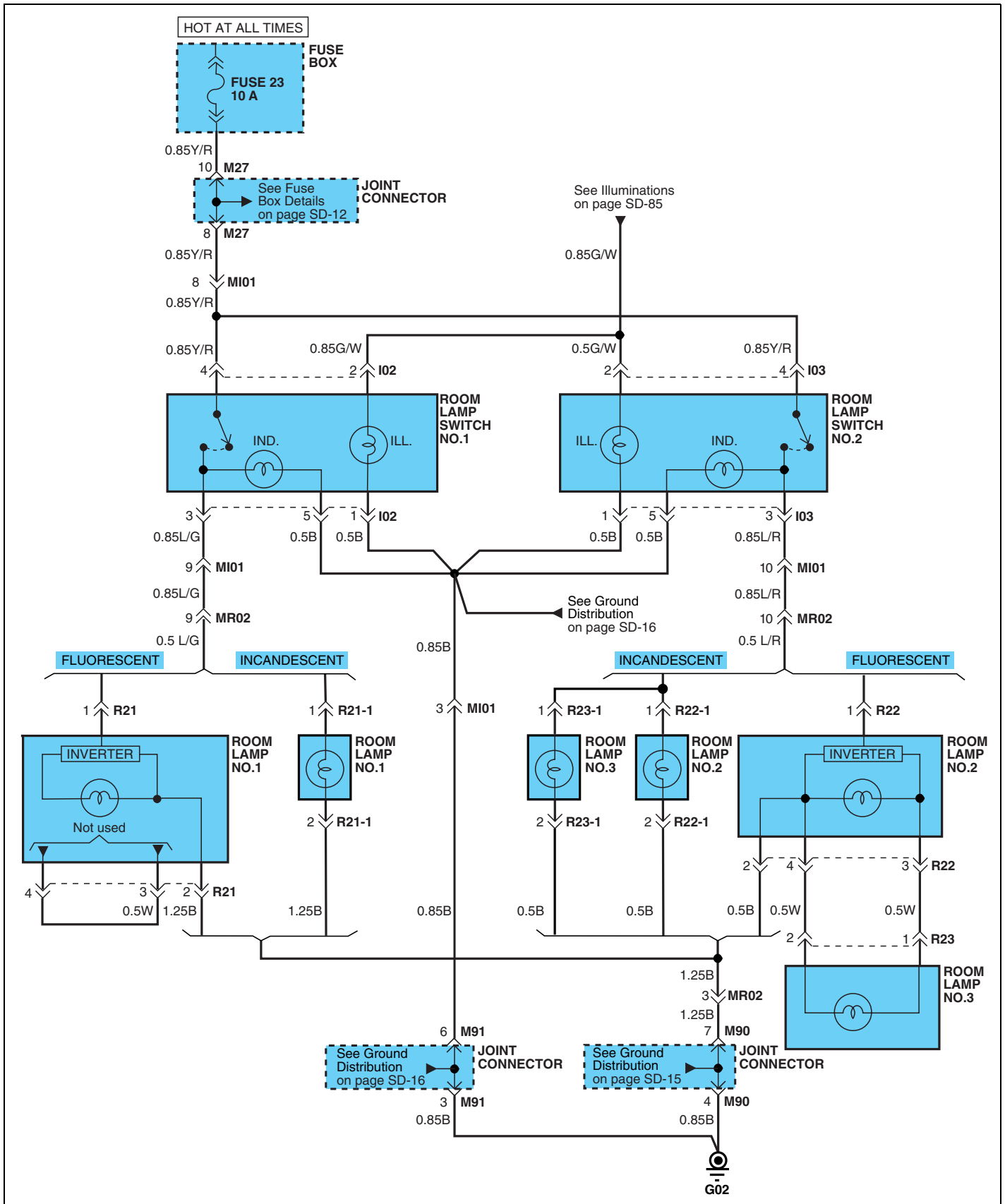

COMPONENT LOCATION INDEX

Components		Location reference-page
I02	Roor lamp switch No.1	CL-15
I03	Roor lamp switch No.2	CL-15
M27	Joint connector	CL- 2
M90	Joint connector	CL- 4
M91	Joint connector	CL- 4
R21	Room lamp No.1 (fluorescent)	CL-17
R21-1	Room lamp No.1 (Incandescent)	CL-17
R22	Room lamp No.2 (fluorescent)	CL-17
R22-1	Room lamp No.2 (Incandescent)	CL-17
R23	Room lamp No.3 (fluorescent)	CL-17
R23-1	Room lamp No.1 (Incandescent)	CL-17
Connectors		
MI01		CL- 6
MR02		CL- 6
Grounds		
G02		CL-19

TAIL, PARKING & LICENSE LAMPS

E450083A

TAIL, PARKING & LICENSE LAMPS (1)

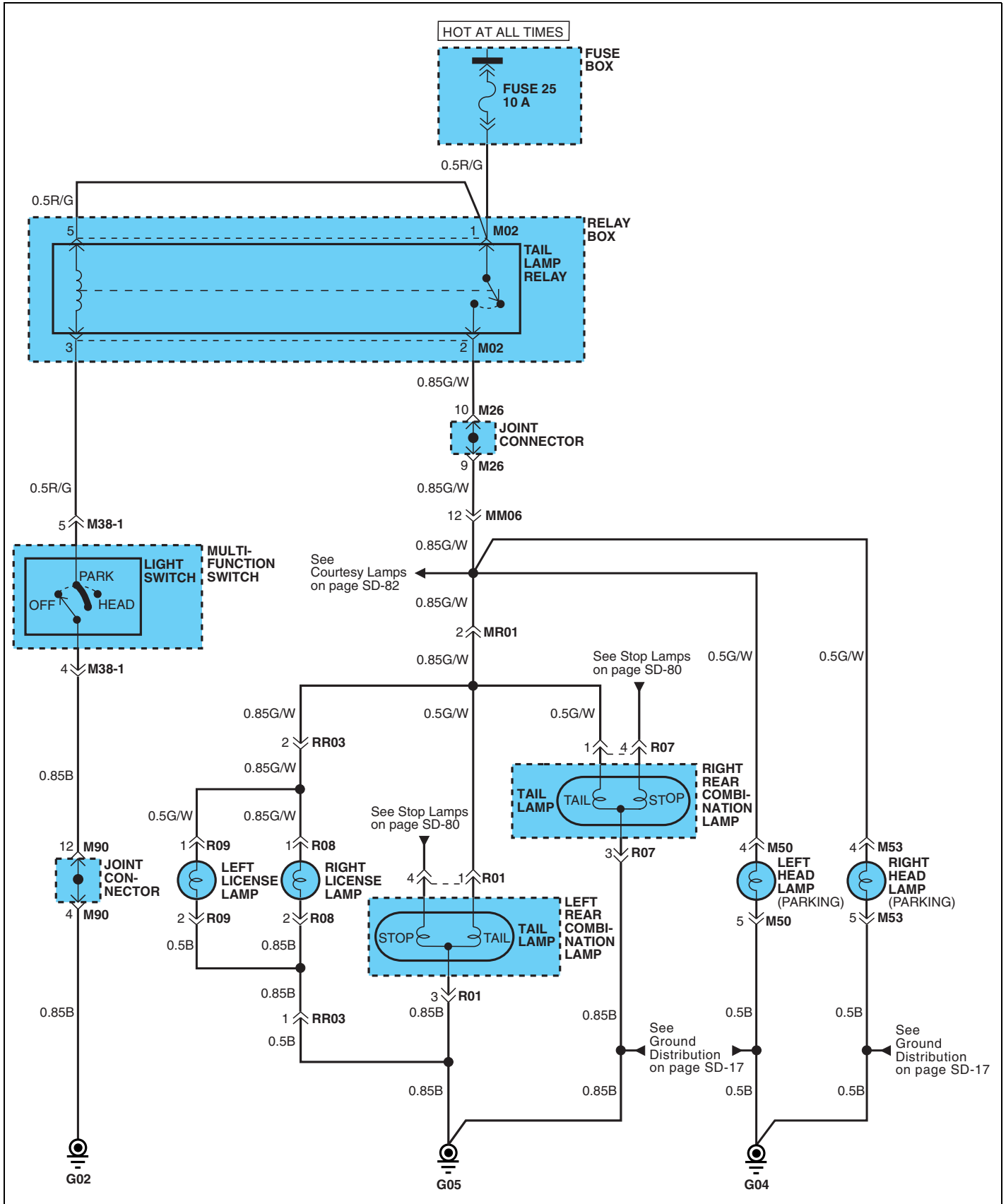

COMPONENT LOCATION INDEX

Components		Location reference-page
M02	Tail lamp relay	CL- 2
M26	Joint connector	CL- 2
M38-1	Multifunction switch	CL- 3
M50	Left head lamp (PARKING)	CL- 7
M53	Right head lamp (PARKING)	CL- 7
M90	Joint connector	CL- 4
R01	Left rear combination lamp	CL-16
R07	Right rear combination lamp	CL-16
R08	Right license lamp	CL-16
R09	Right license lamp	CL-16
Connectors		
MM06		CL- 6
MR01		CL-12
RR03		CL-16
Grounds		
G02		CL-19
G04		CL-19
G05		

READING LAMPS

E63C5FC1

READING LAMPS (1)

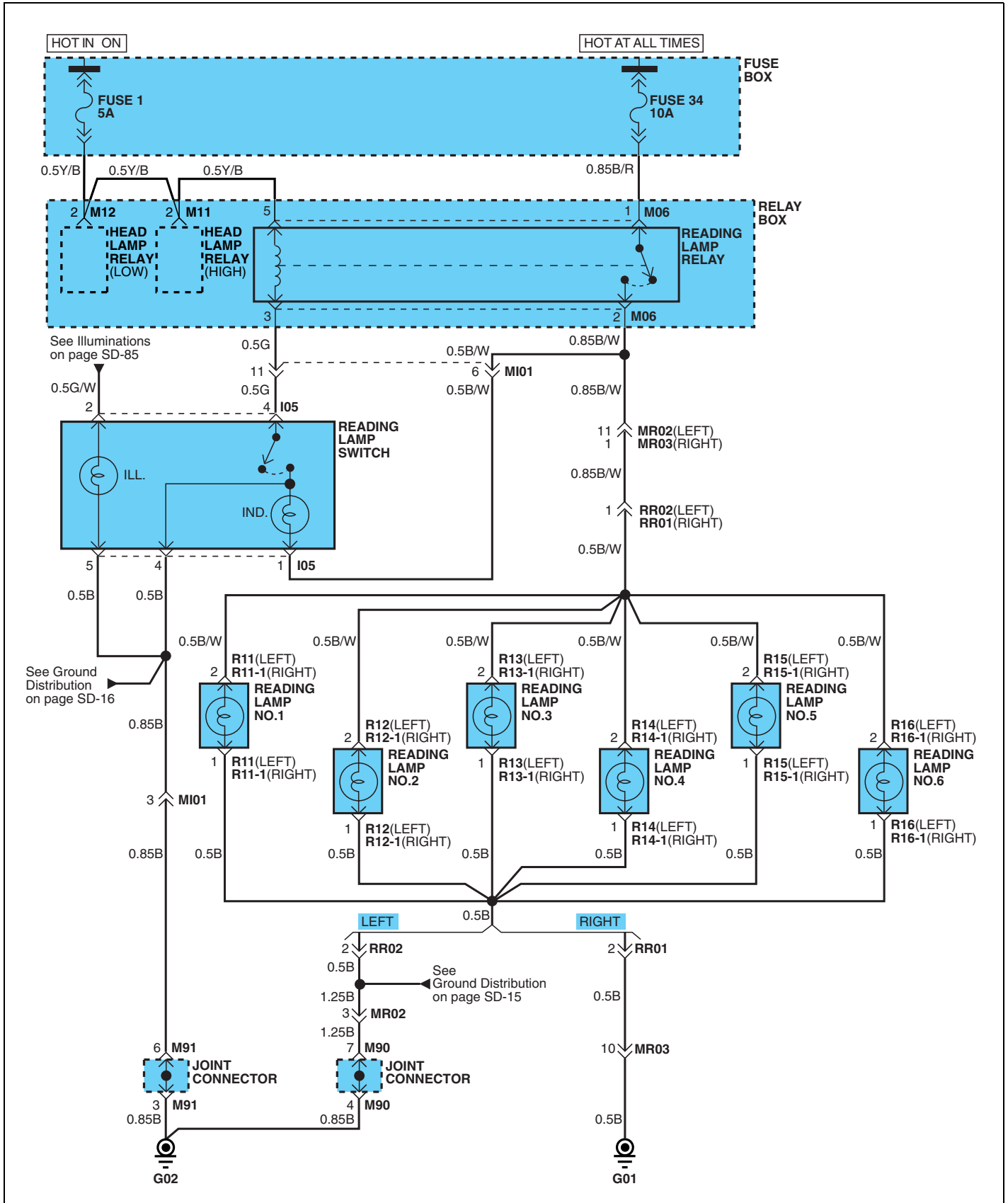

COMPONENT LOCATION INDEX

Components		Location reference-page
I05	Reading lamp switch	CL-15
M06	Reading lamp relay	CL- 2
M11	Head lamp relay (high)	CL- 2
M12	Head lamp relay (low)	CL- 2
M90	Joint connector	CL- 4
M91	Joint connector	CL- 4
R11	Left reading lamp No.1	CL-17
R11-1	Right reading lamp No.1	CL-17
R12	Left reading lamp No.2	CL-17
R12-1	Right reading lamp No.2	CL-17
R13	Left reading lamp No.3	CL-17
R13-1	Right reading lamp No.3	CL-17
R14	Left reading lamp No.4	CL-17
R14-1	Right reading lamp No.4	CL-17
R15	Left reading lamp No.5	CL-17
R15-1	Right reading lamp No.5	CL-17
R16	Left reading lamp No.6	CL-17
R16-1	Right reading lamp No.6	CL-17
Connectors		
MI01		CL- 6
MR02		CL- 6
MR03		CL- 6
RR01		CL-18
RR02		CL-18
Grounds		
G01		CL-19
G02		CL-19

STOP LAMPS

EB3D51ED

STOP LAMPS (1)

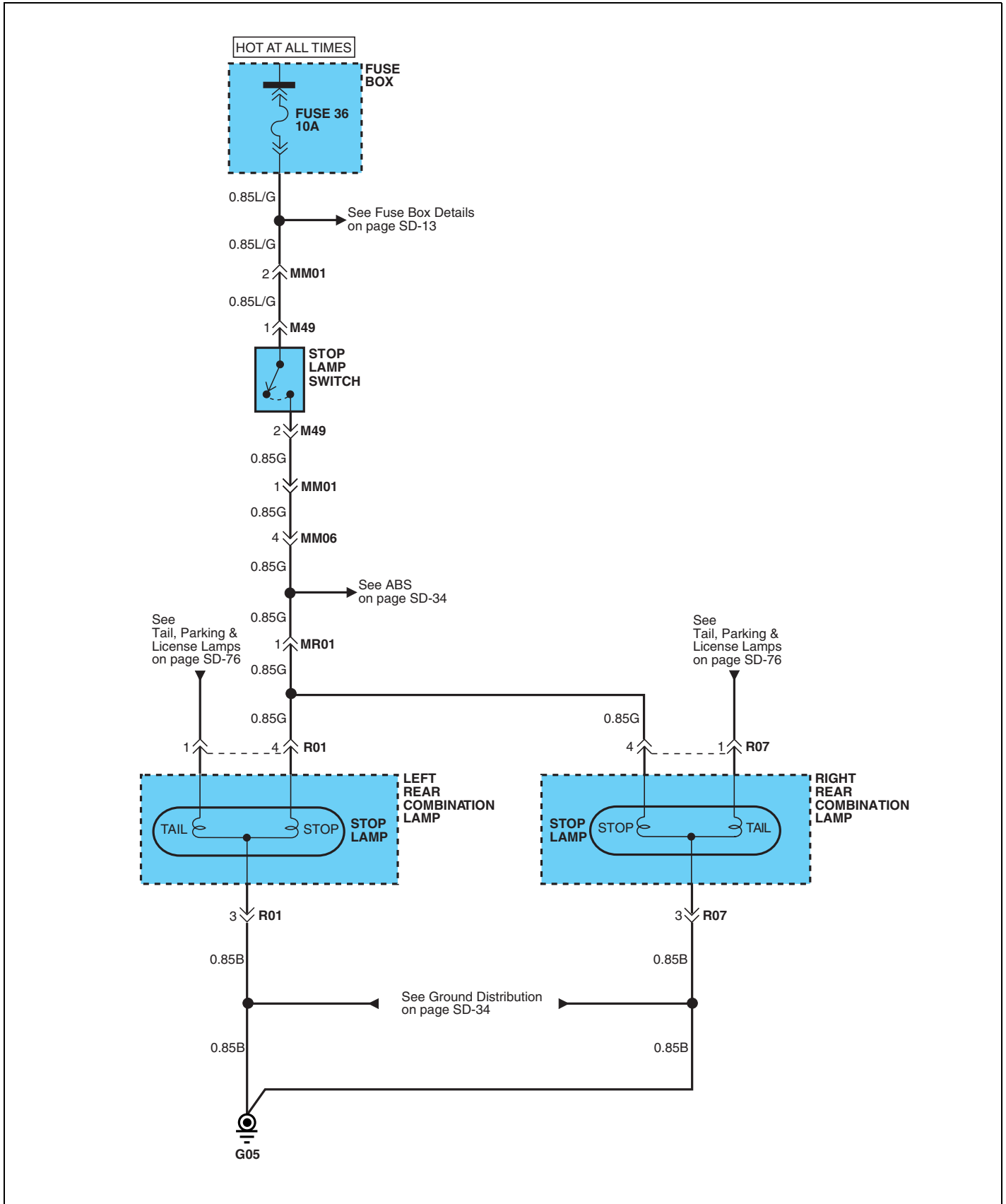

COMPONENT LOCATION INDEX

Components		Location reference-page
M49	Stop lamp switch	CL- 4
R01	Left rear combination lamp	CL-16
R07	Right rear combination lamp	CL-16
Connectors		
MM01		CL- 6
MM06		CL- 6
MR01		CL-12
Grounds		
G05		CL-19

COURTESY LAMPS

EEC0D5E5

COURTESY LAMPS (1)

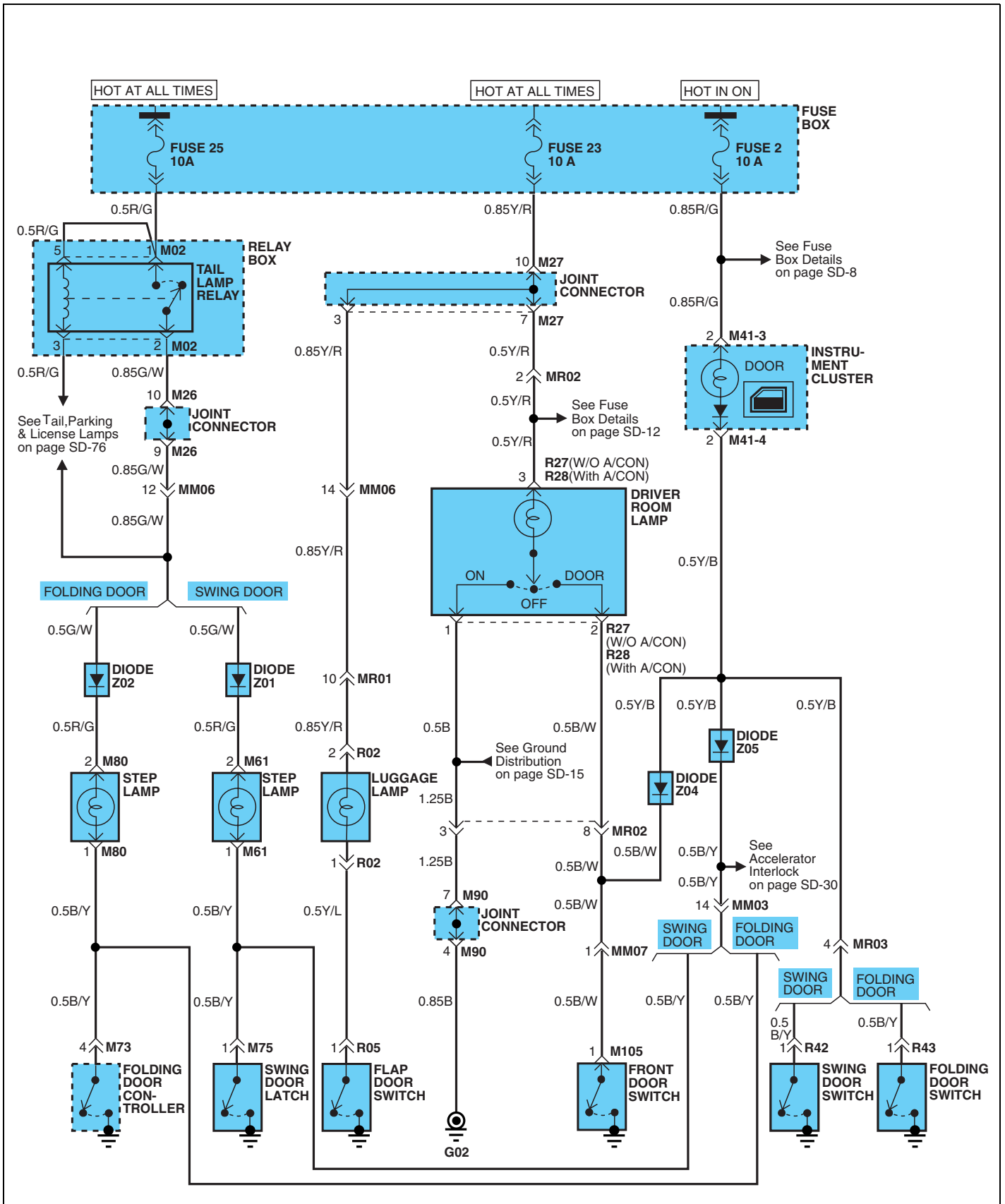

COMPONENT LOCATION INDEX

Components		Location reference-page
M02	Tail lamp relay	CL- 2
M26	Joint connector	CL- 2
M27	Joint connector	CL- 2
M41-3	Instrument cluster	CL- 3
M41-4	Instrument cluster	CL- 3
M61	Step lamp (Swing door)	CL- 8
M73	Folding door controller	CL- 9
M75	Swing door latch	CL- 8
M80	Step lamp (Folding door)	CL- 9
M105	Front door switch	CL-11
R02	Luggage lamp	CL-16
R05	Flap door switch	CL-16
R27	Driver room lamp	CL-17
R28	Driver room lamp	CL-17
R42	Swing door switch	CL-18
R43	Folding door switch	CL-18
Connectors		
MM03		CL- 6
MM06		CL- 6
MM07		CL- 6
MR02		CL- 6
MR03		CL- 6
Grounds		
G02		CL-19
Diodes		
Z01		CL-20
Z04		CL-20
Z05		CL-20

ILLUMINATIONS

EE2D1E2B

ILLUMINATIONS (1)

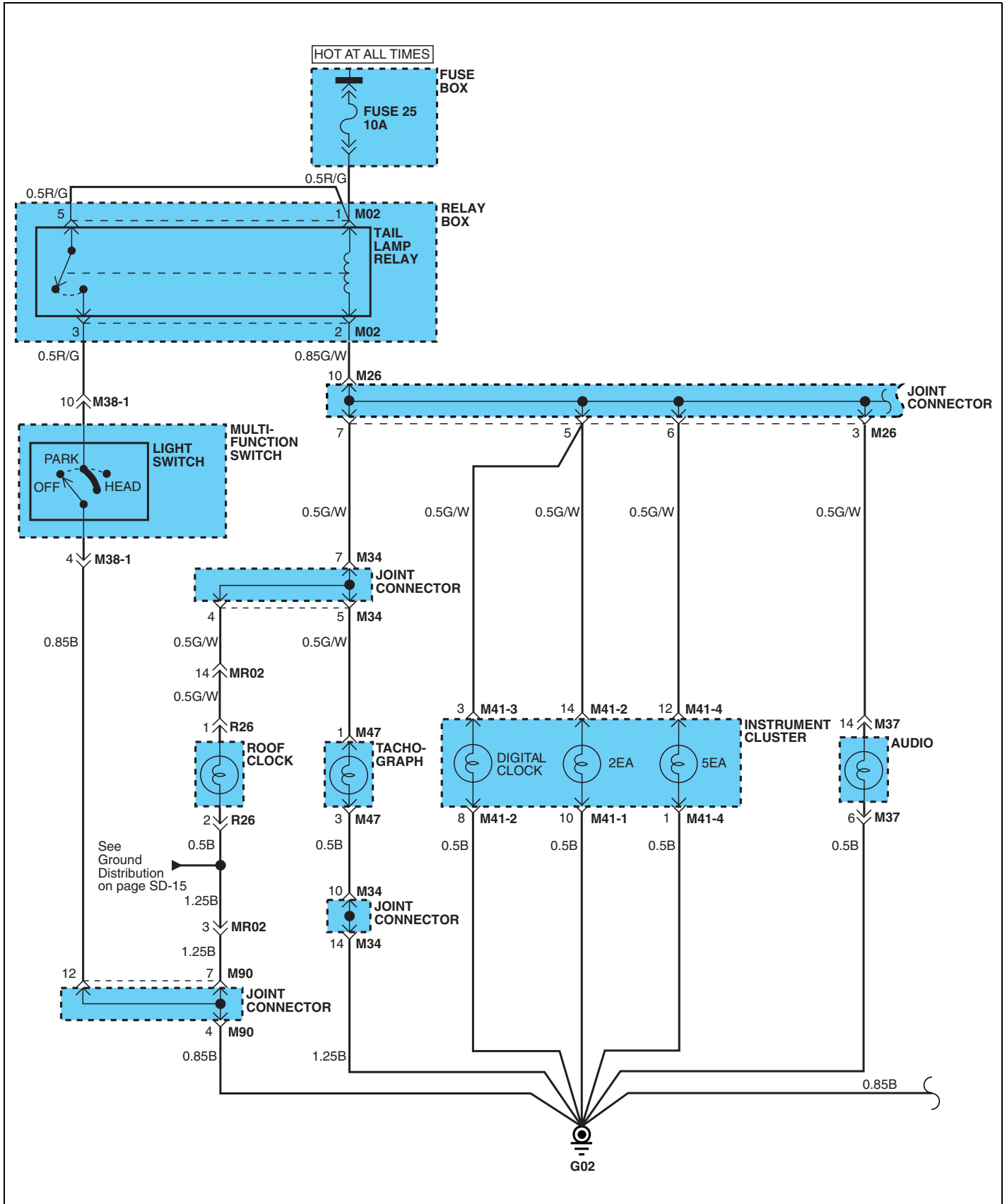

ILLUMINATIONS (2)

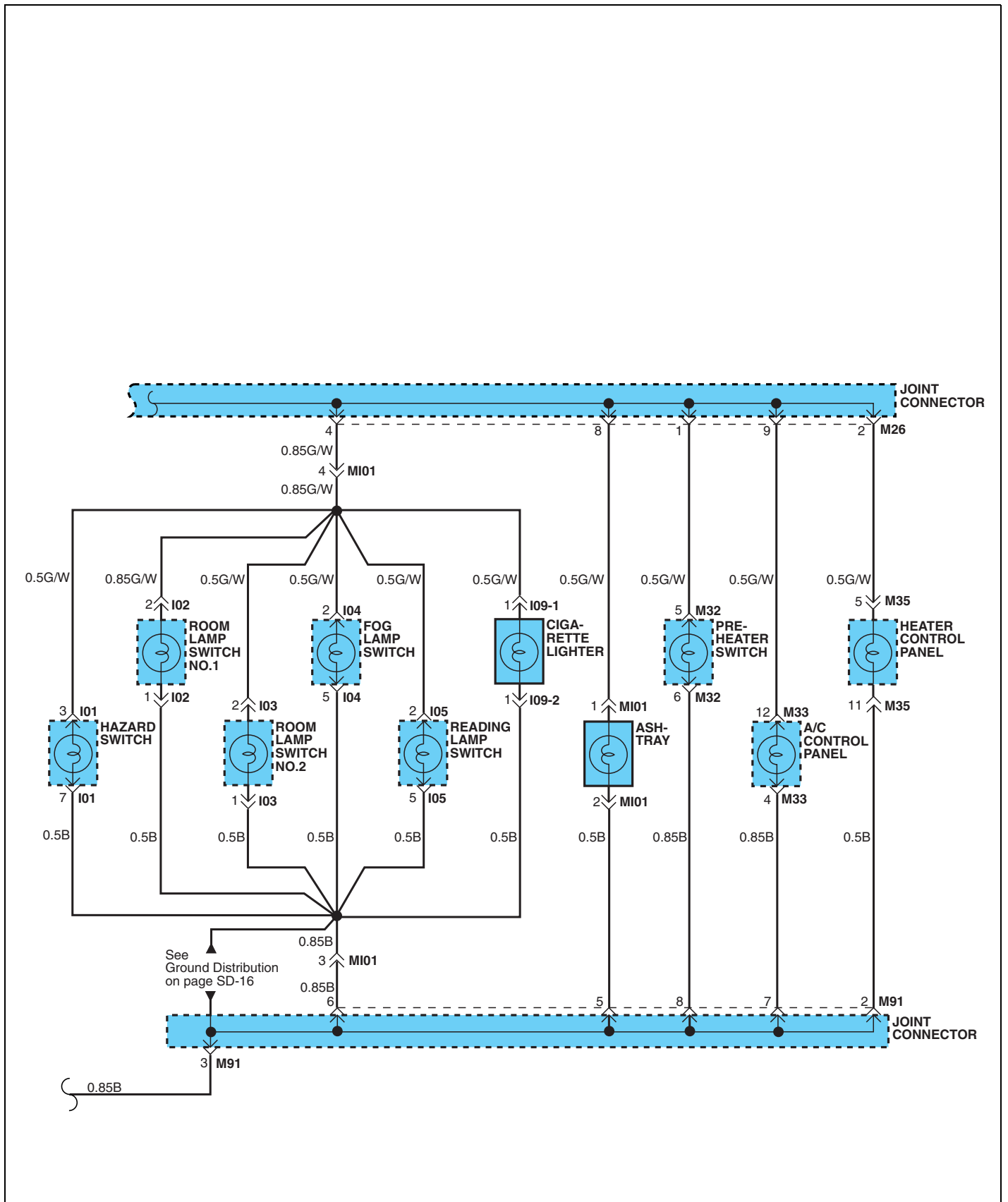

COMPONENT LOCATION INDEX

Components		Location reference-page
I01	Hazard switch	CL-15
I02	Room lamp switch No.1	CL-15
I03	Room lamp switch No.2	CL-15
I04	Fog lamp switch	CL-15
I05	Reading lamp switch	CL-15
I09-1	Cigarette lighter	CL-15
I09-2	Cigarette lighter	CL-15
M02	Tail lamp relay	CL- 2
M26	Joint connector	CL- 2
M32	Preheater switch	CL- 3
M33	A/C control panel	CL- 2
M34	Joint connector	CL- 3
M37	Audio	CL- 3
M38-1	Multifunction switch	CL- 3
M41-1	Instrument cluster	CL- 3
M41-2	Instrument cluster	CL- 3
M41-3	Instrument cluster	CL- 3
M41-4	Instrument cluster	CL- 3
M47	Tachograph	CL- 4
M90	Joint connector	CL- 4
M91	Joint connector	CL- 4
M101	Ashtray	CL- 5
Connectors		
MI01		CL- 6
Grounds		
G02		CL-19

MEMO

A large, empty rectangular box with a thin black border, occupying most of the page. It is intended for the main content of the memo.

HEATER & VENTILATOR CONTROL SYSTEM

E4D727E3

HEATER & VENTILATOR CONTROL SYSTEM (1)

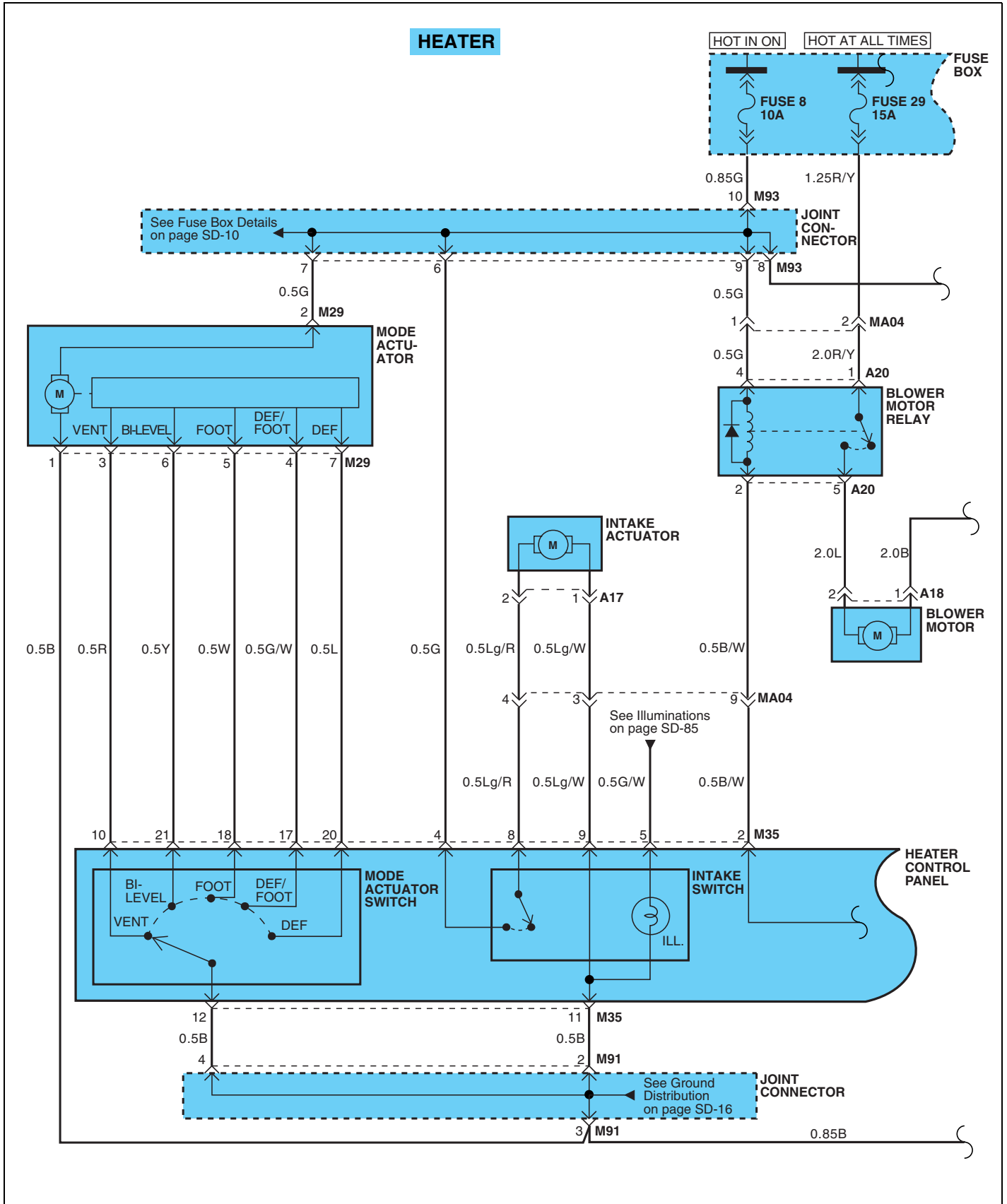

HEATER & VENTILATOR CONTROL SYSTEM (2)

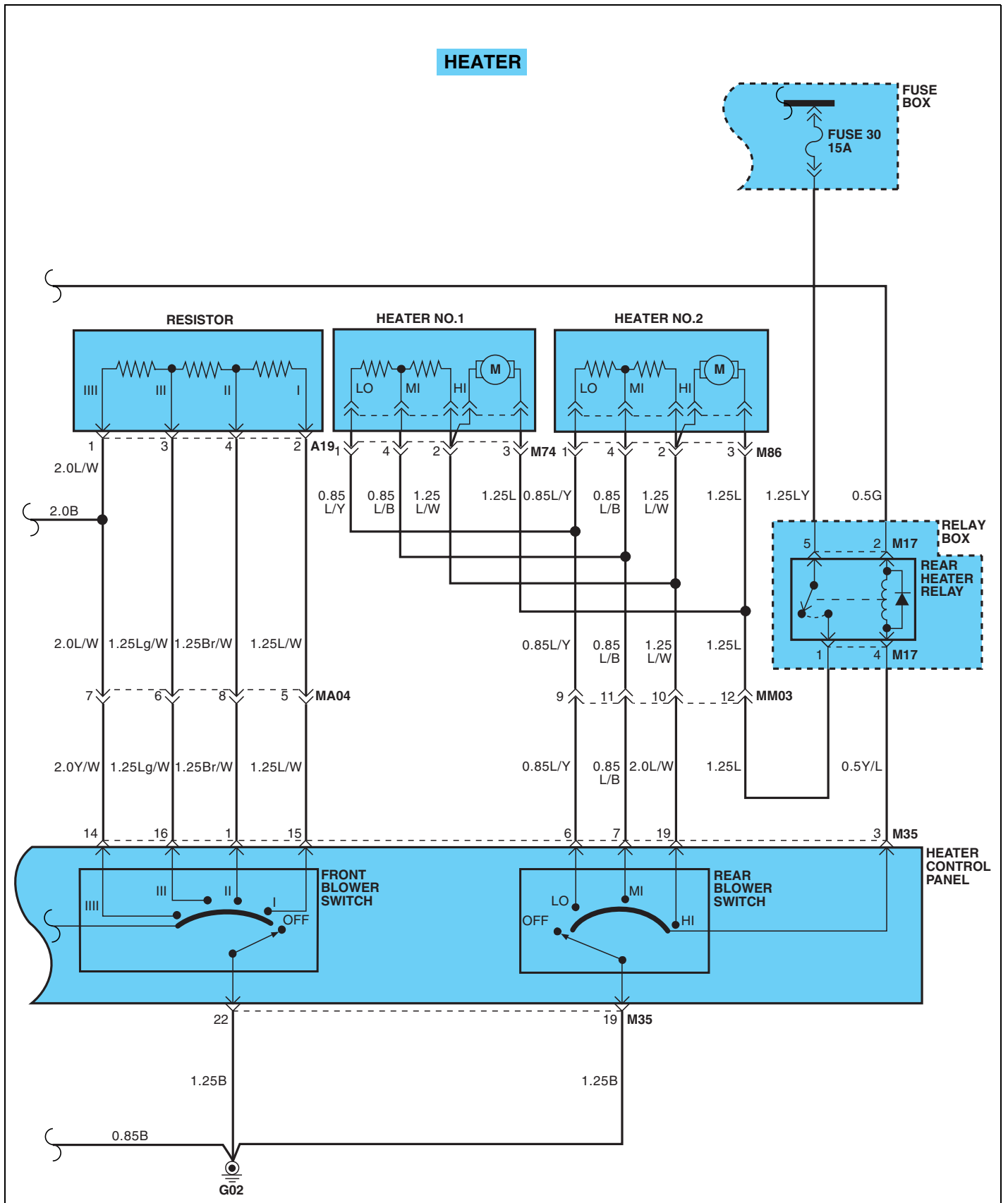

HEATER & VENTILATOR CONTROL SYSTEM (3)

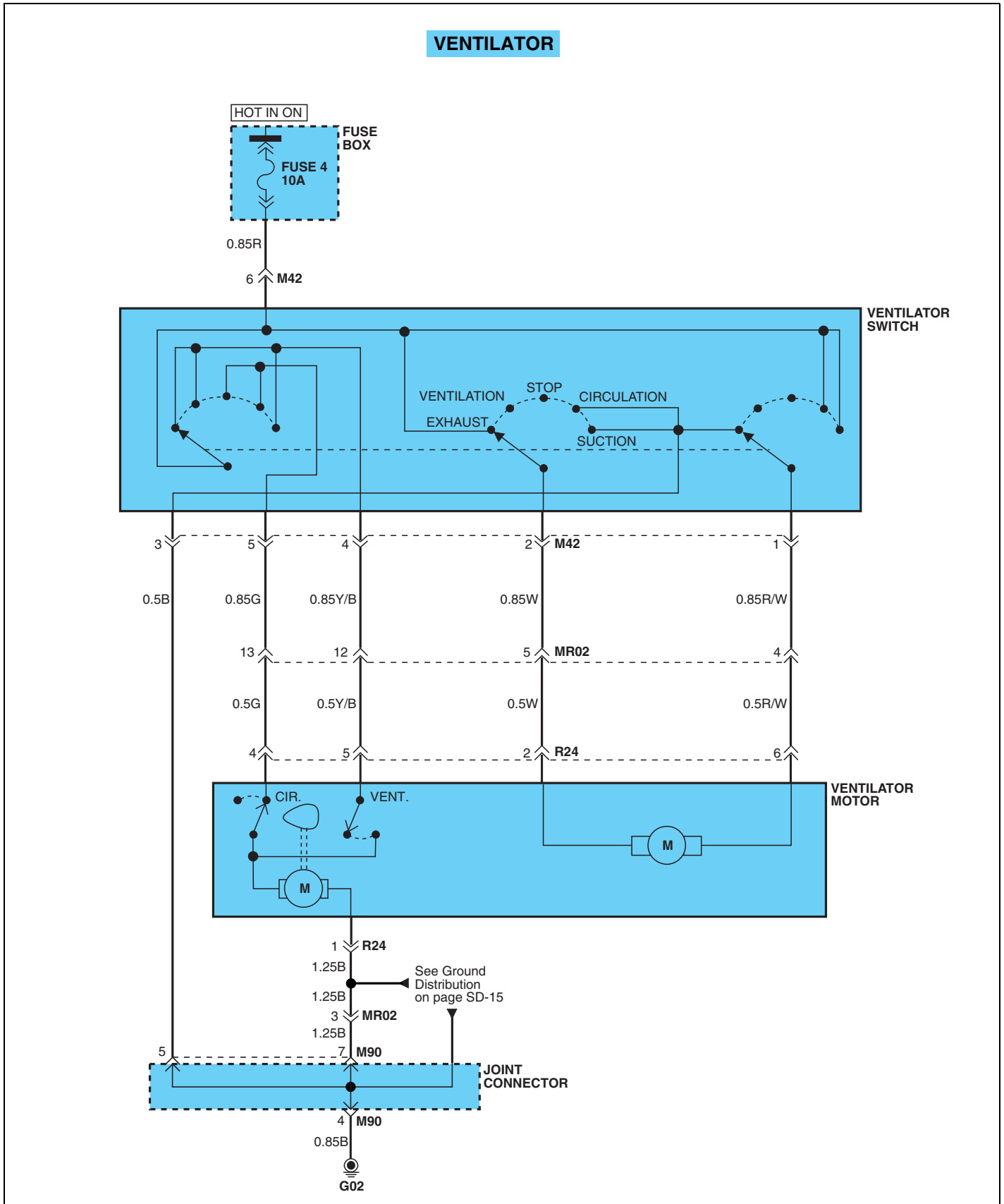

COMPONENT LOCATION INDEX

Components		Location reference-page
A17	Intake actuator	CL-14
A18	Blower motor	CL-14
A19	Resistor	CL-14
A20	Blower motor relay	CL-14
M17	Rear heater relay	CL- 2
M27	Joint connector	CL- 2
M29	Mode actuator	CL- 2
M34	Joint connector	CL- 3
M35	Heater control panel	CL- 3
M42	Ventilator switch	CL- 3
M74	Heater No.1	CL- 9
M86	Heater No.2	CL-10
M93	Joint connector	CL- 4
R24	Ventilator motor	CL-17
Connectors		
MA04		CL- 5
MM03		CL- 6
MR02		CL- 6
Grounds		
G02		CL-19

A/C CONTROLS

E48321E9

A/C CONTROLS (1)

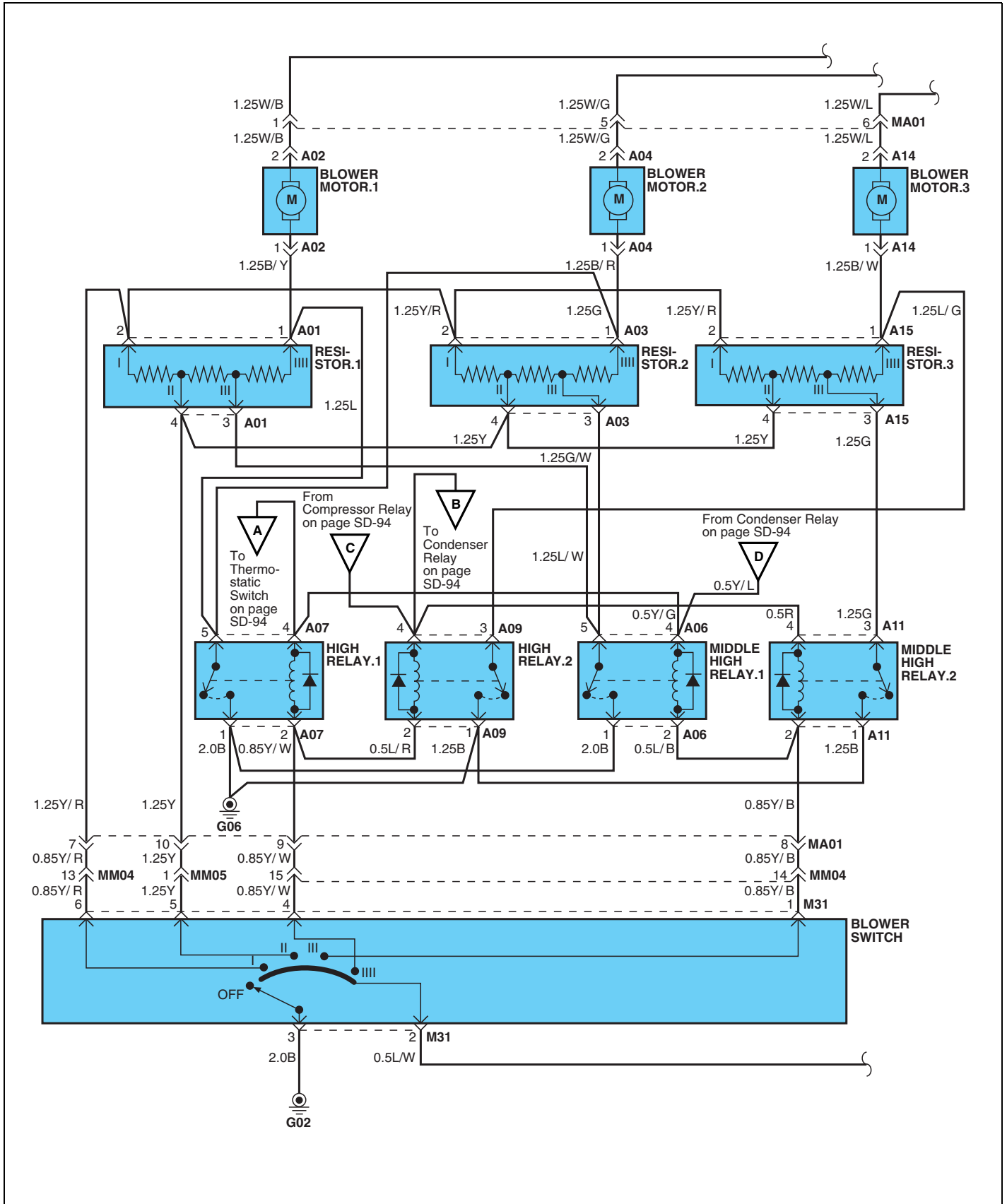

A/C CONTROLS (2)

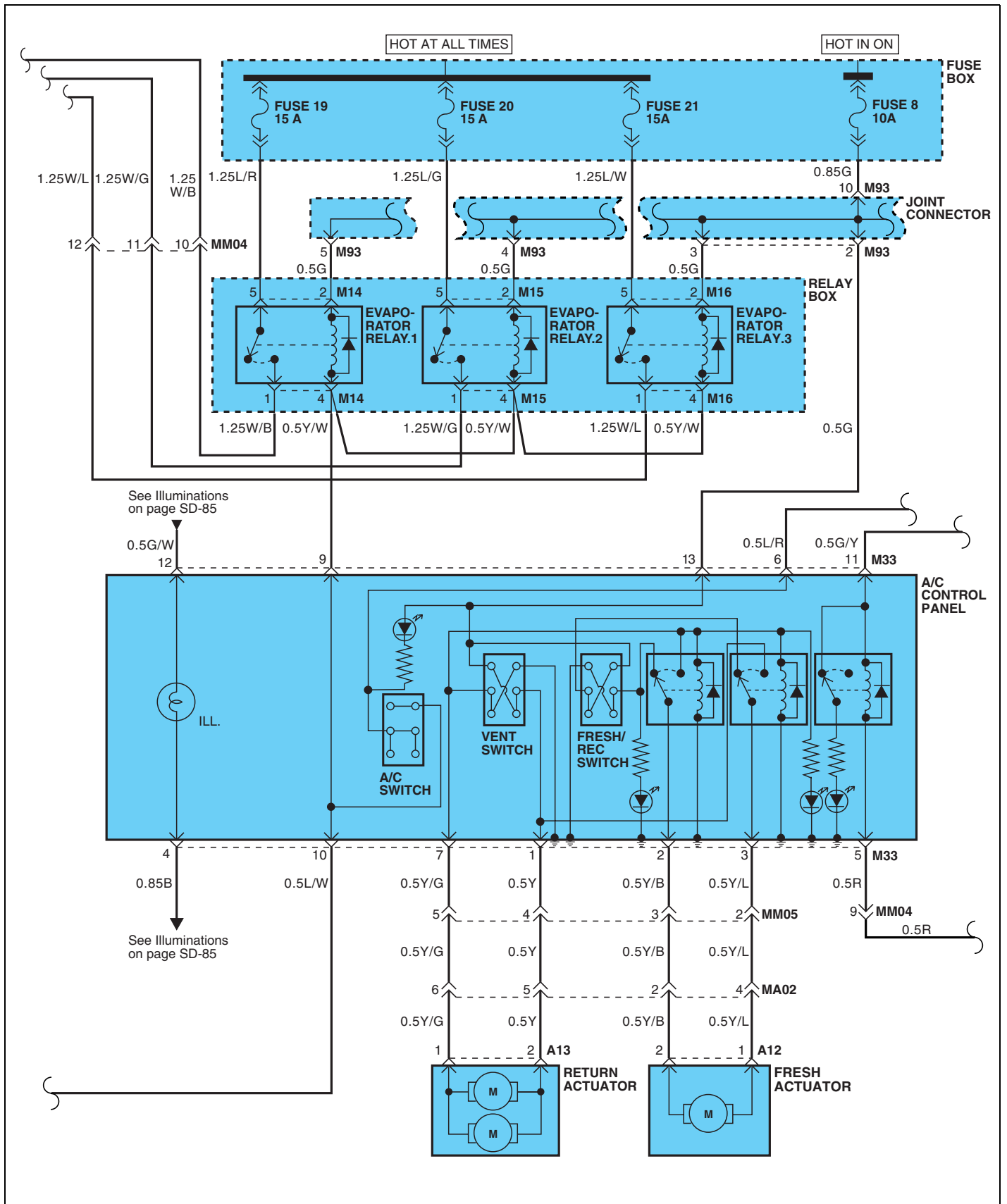

A/C CONTROLS (3)

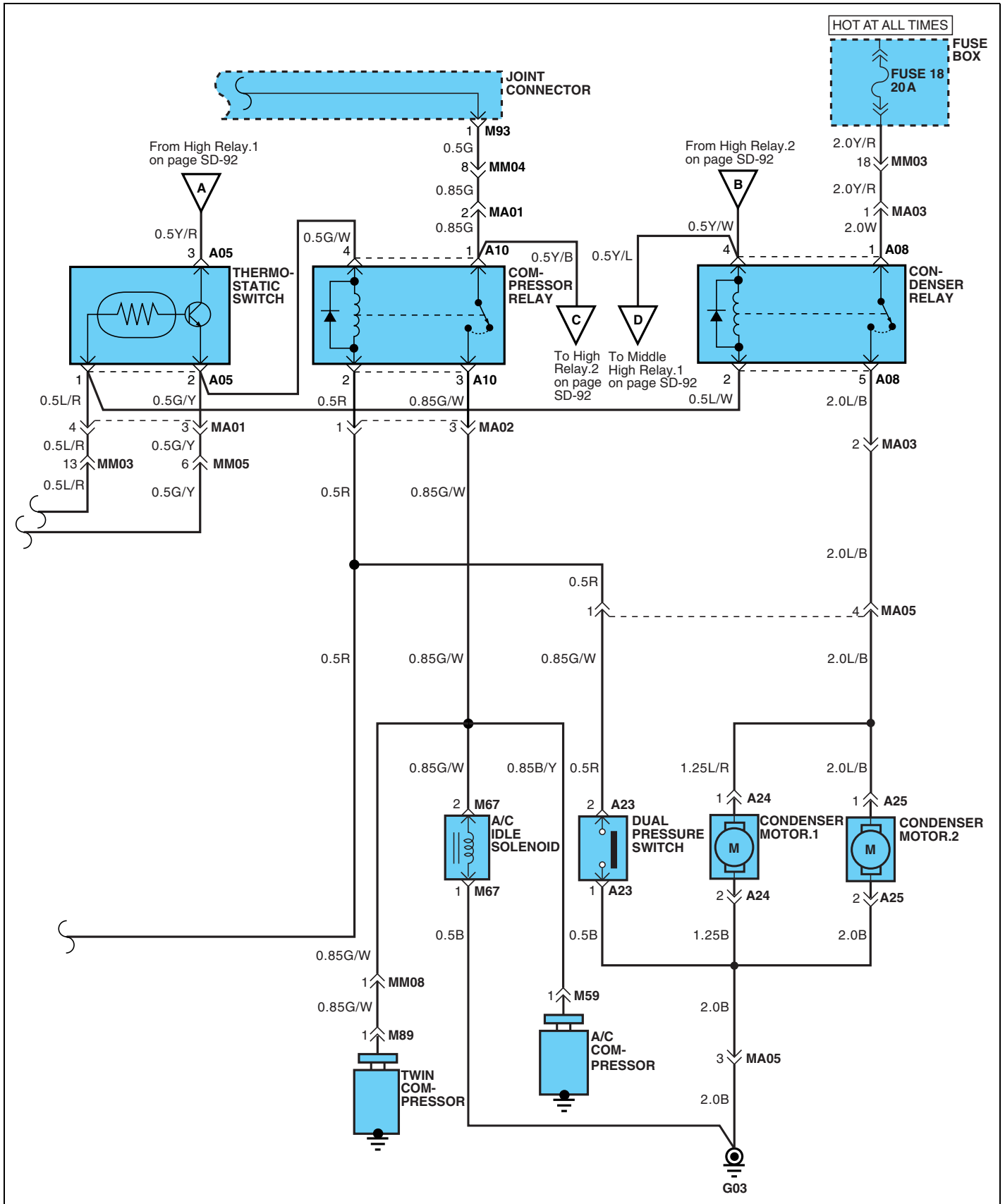

COMPONENT LOCATION INDEX

Components		Location reference-page
A01	Resistor.1	CL-14
A02	Blower motor.1	CL-14
A03	Resistor.2	CL-14
A04	Blower motor.2	CL-14
A05	Thermostatic switch	CL-14
A06	Middle high relay.1	CL-14
A07	High relay.1	CL-14
A08	Condenser relay	CL-14
A09	High relay.2	CL-14
A10	Compressor relay	CL-14
A11	Middle high relay.2	CL-14
A12	Fresh actuator	CL-14
A13	Return actuator	CL-14
A14	Blower motor.3	CL-14
A15	Resistor.3	CL-14
A23	Dual pressure switch	CL-14
A24	Condenser motor.1	CL-14
A25	Condenser motor.2	CL-14
M14	Evaporator relay.1	CL- 2
M15	Evaporator relay.2	CL- 2
M16	Evaporator relay.3	CL- 2
M27	Joint connector	CL- 2
M31	A/C switch	CL- 3
M33	A/C control panel	CL- 3
M34	Joint connector	CL- 3
M59	A/C compressor	CL- 7
M67	A/C idle solenoid	CL- 8
M89	Twin compressor	CL-10
M93	Joint connector	CL- 4
Connectors		
MA01		CL-12
MA02		CL-12
MA03		CL-12
MA05		CL-12
MM03		CL- 6
MM04		CL- 6
MM05		CL- 6
MM08		CL-12
Grounds		
G02		CL-19
G03		CL-19
G06		CL-19

Component Location

MAIN HARNESS	CL- 2
UNDER FLOOR HARNESS	CL- 7
ENGINE HARNESS	CL-13
A/C HARNESS	CL-14
FACIA & DOOR HARNESS	CL-15
REAR BODY & LICENSE HARNESS	CL-16
ROOM LAMP & SPEAKER HARNESS	CL-17
GROUNDS	CL-19
DIODES	CL-20

MAIN HARNESS E5D7E1A4

MAIN HARNESS (1)

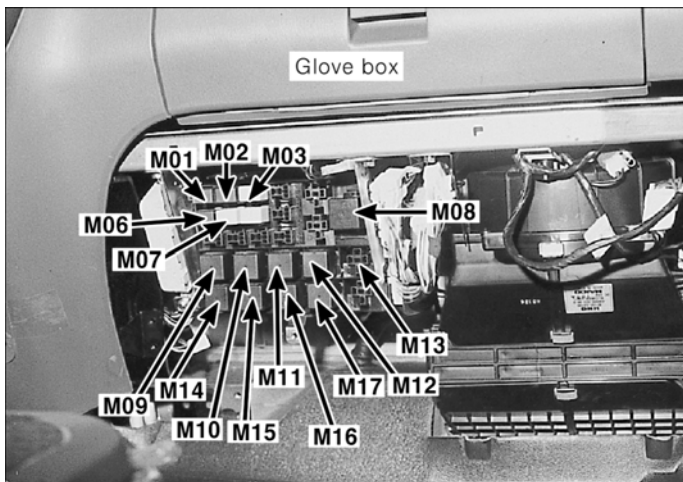

E3QD001A

M01~M17

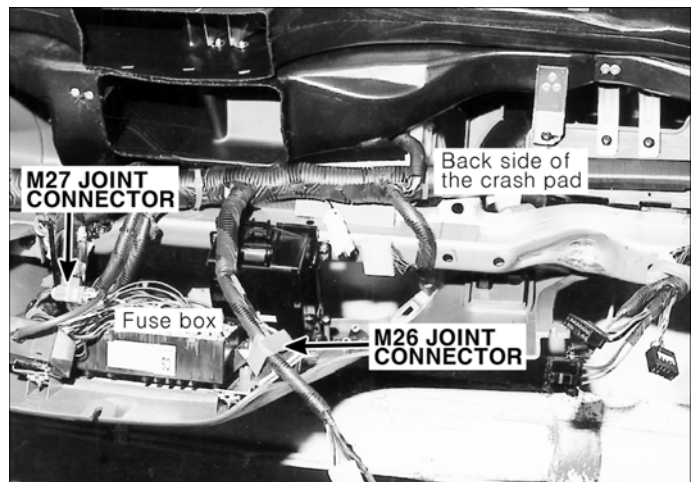

E3QD001D

M26, M27

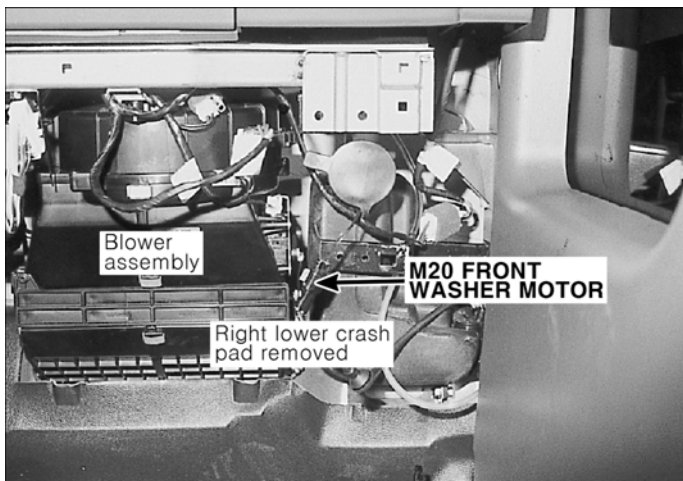

E3QD001B

M20

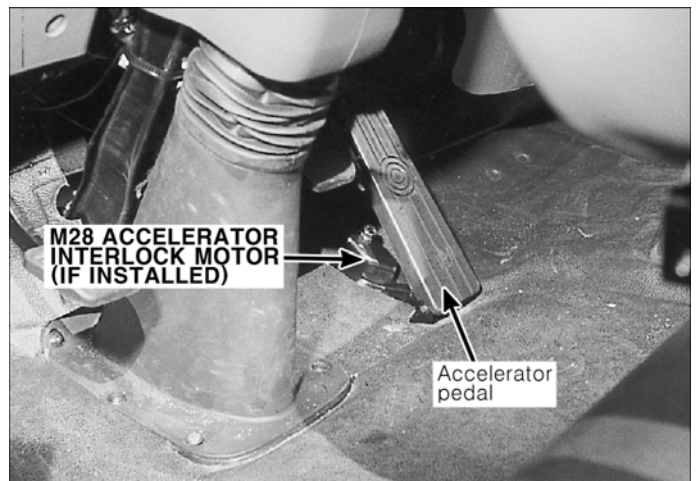

E3QD001E

M28

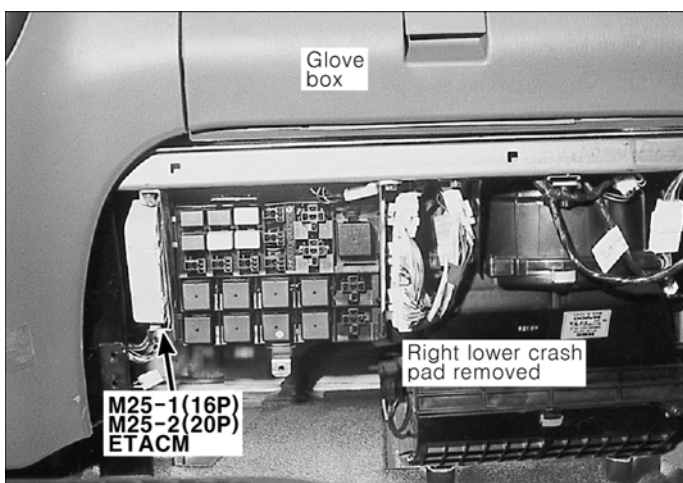

E3QD001C

M25-1, M25-2

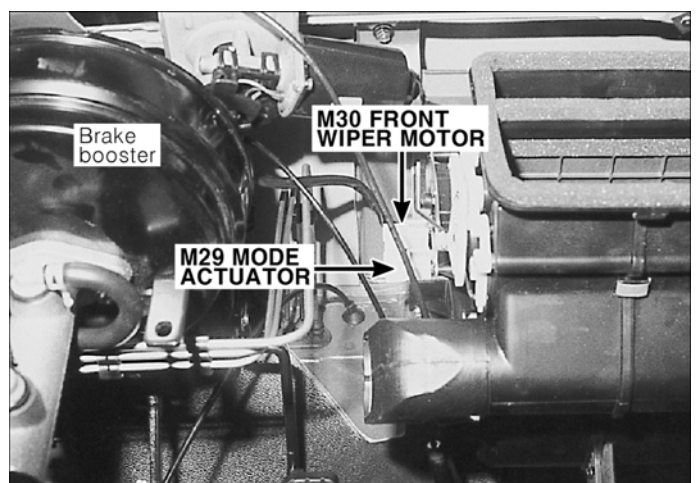

E3QD001F

M29, M30

MAIN HARNESS (2)

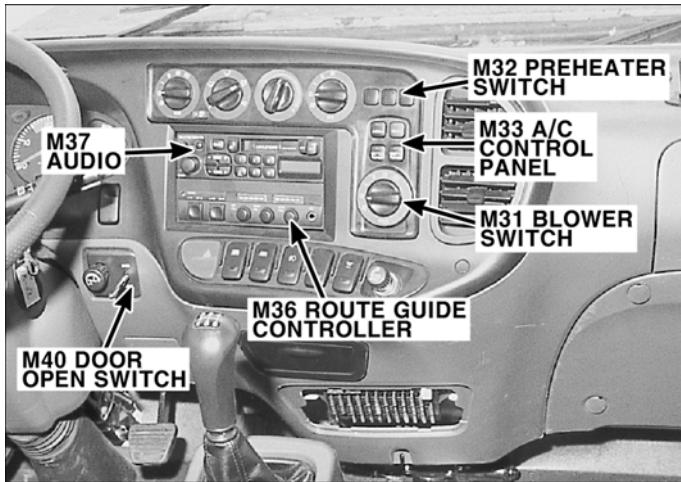

E3QD001G

M31, M32, M33, M36, M37, M40

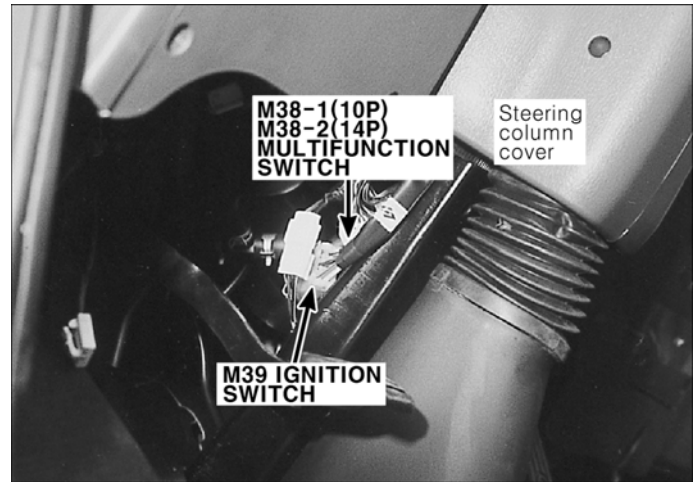

E3QD001K

M38-1, M38-2, M39

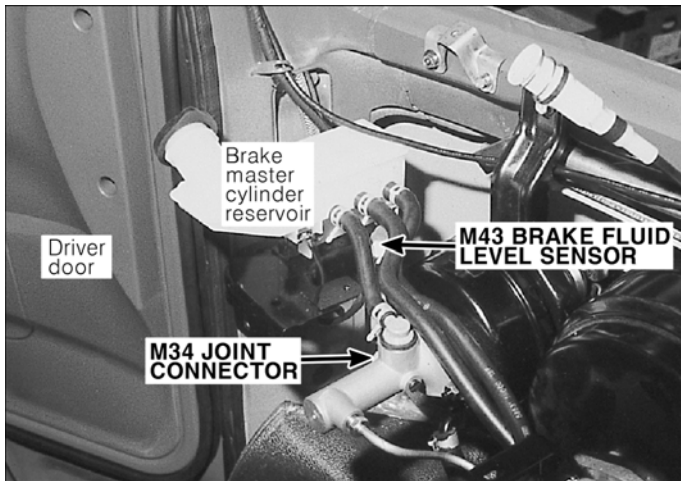

E3QD001H

M34, M43

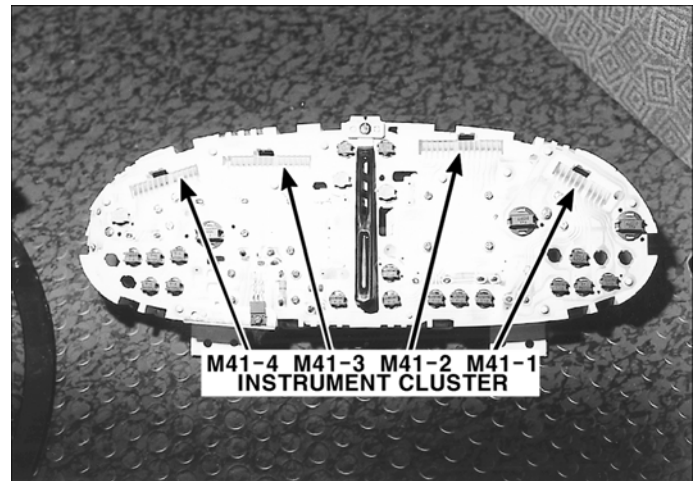

E3QD001L

M41-1, M41-2, M41-3, M41-4

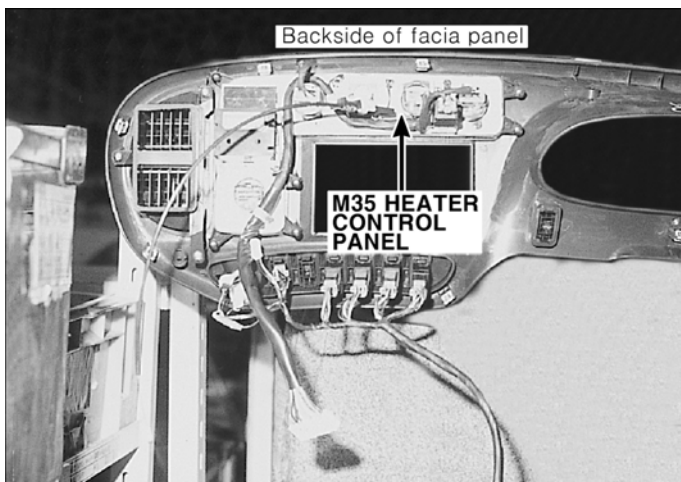

E3QD001J

M35

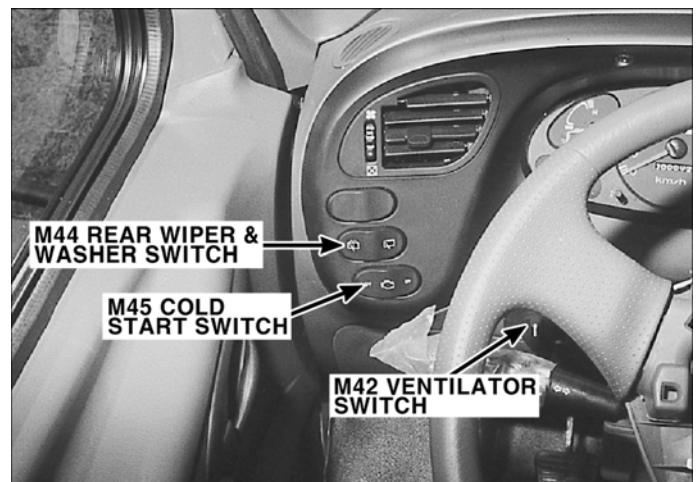

E3QD001M

M42, M44, M45

MAIN HARNESS (3)

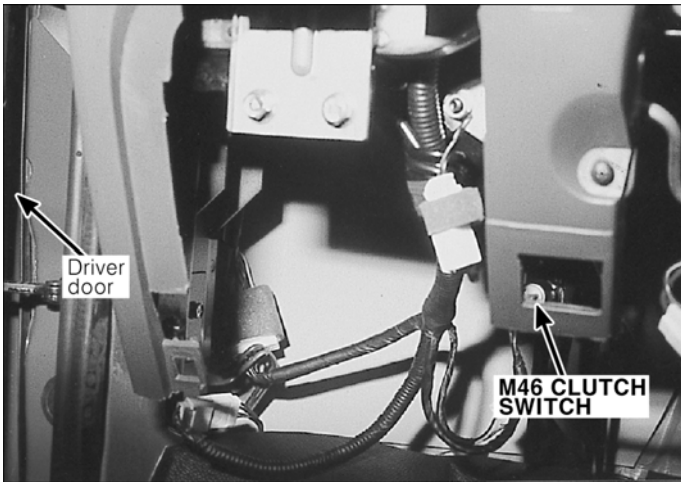

E3QD001N

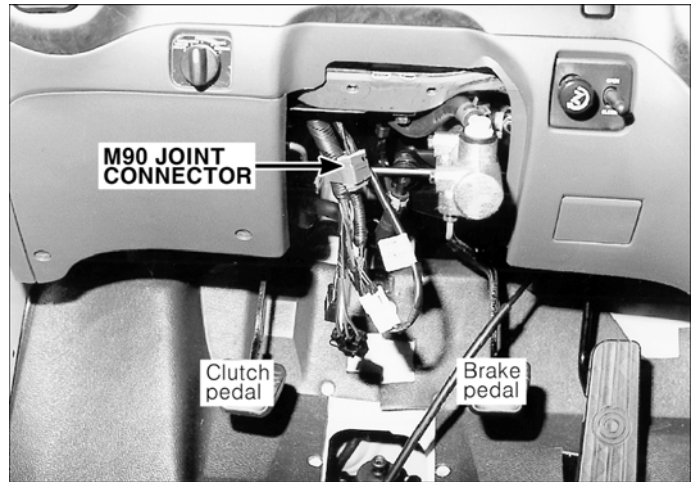

E3QD001R

M46

M90

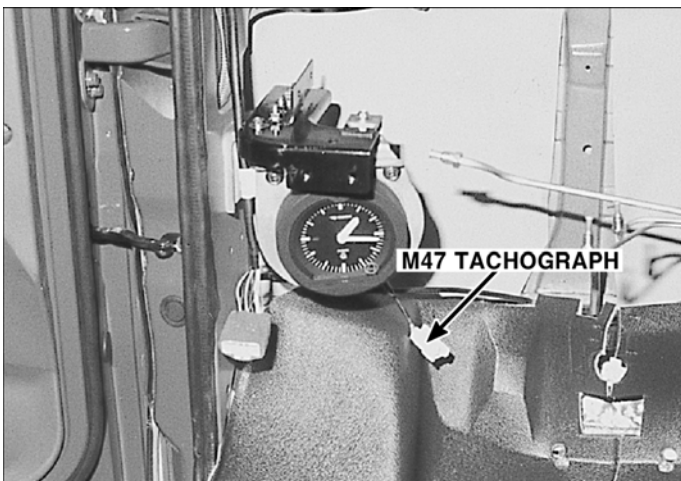

E3QD001P

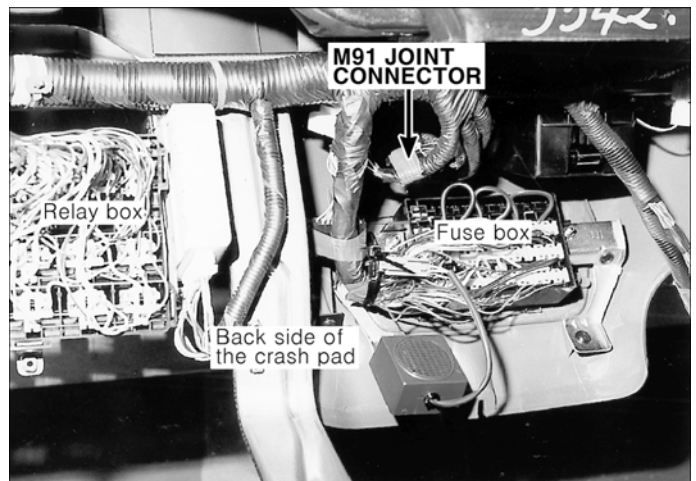

E3QD001S

M47

M91

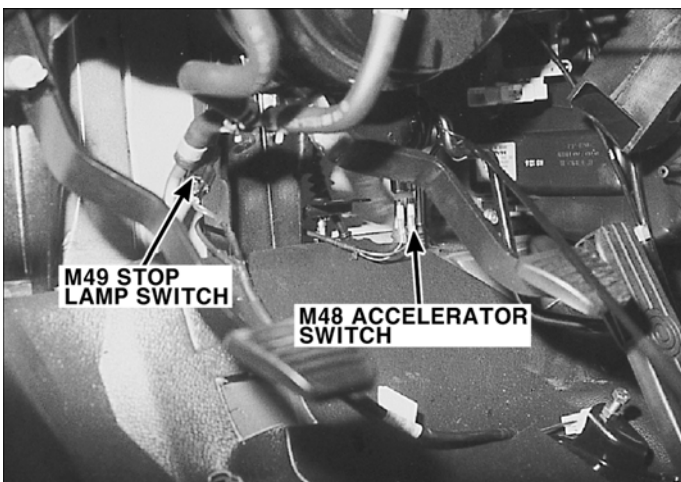

E3QD001Q

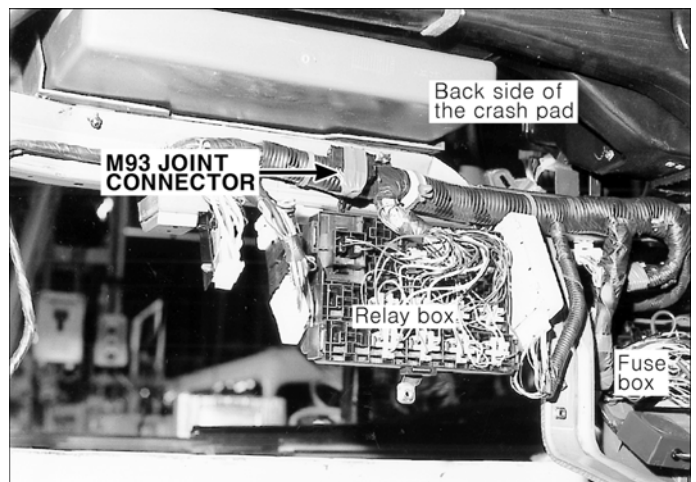

E3QD001T

M48, M49

M93

MAIN HARNESS (4)

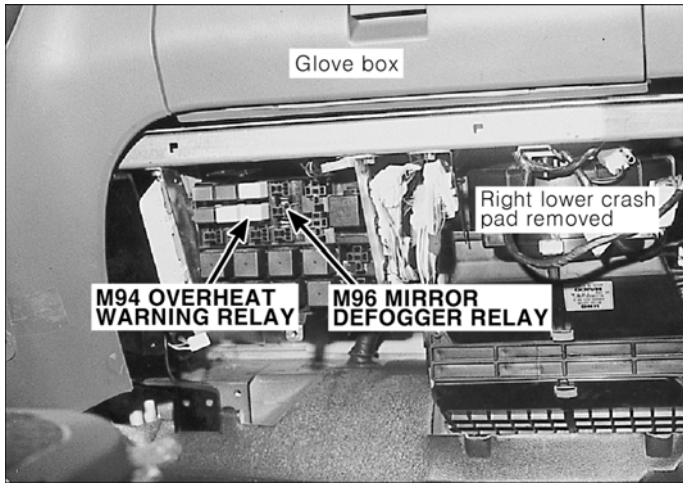

E3QD001U

M94, M96



E3QD001X

M99, M102

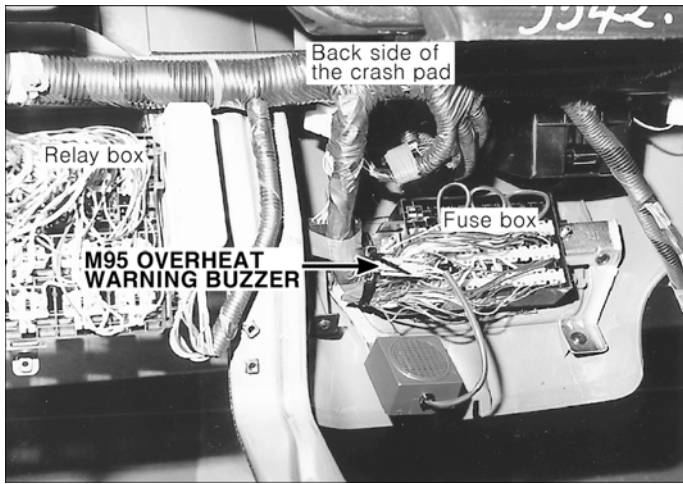

E3QD001V

M95

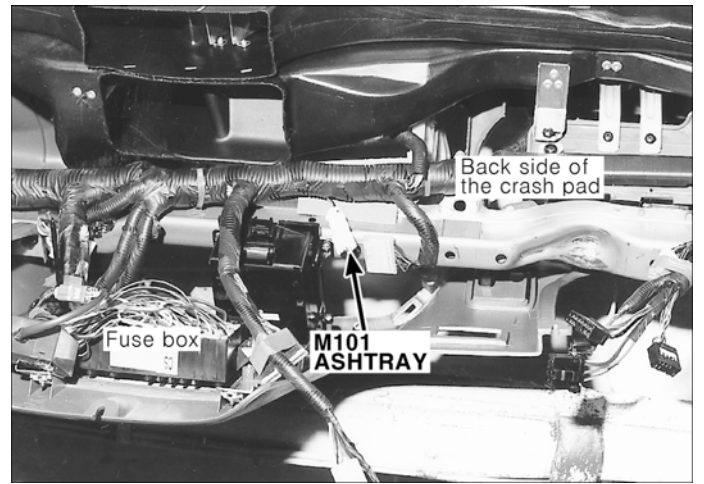

E3QD001Y

M101

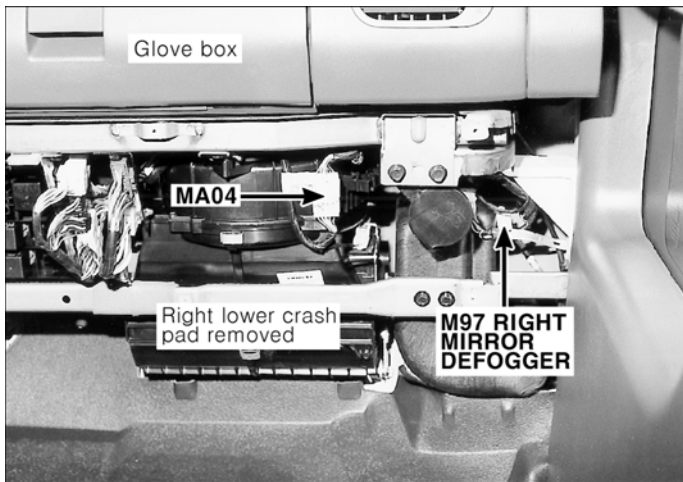

E3QD001W

M97, MA04

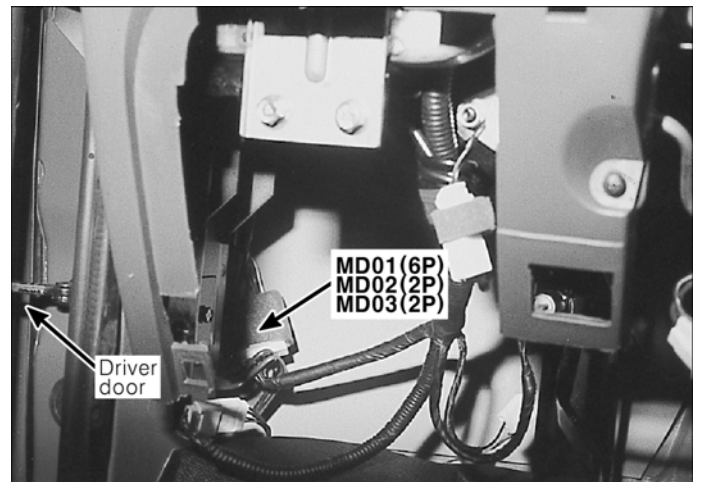

E3QD001Z

MD01, MD02, MD03

MAIN HARNESS (5)

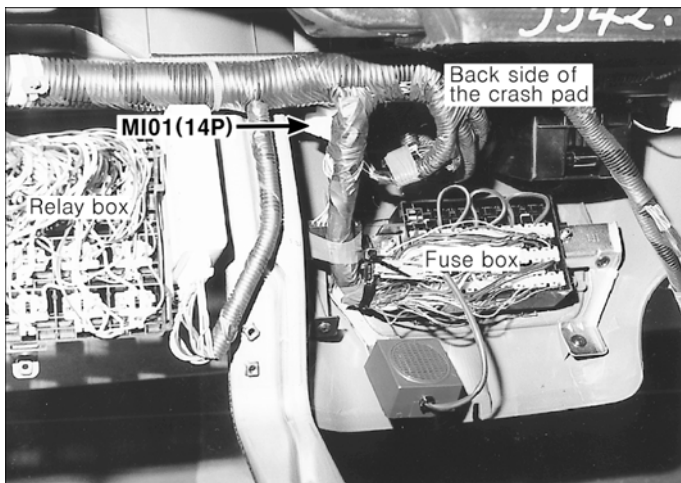

E3QD0A1A

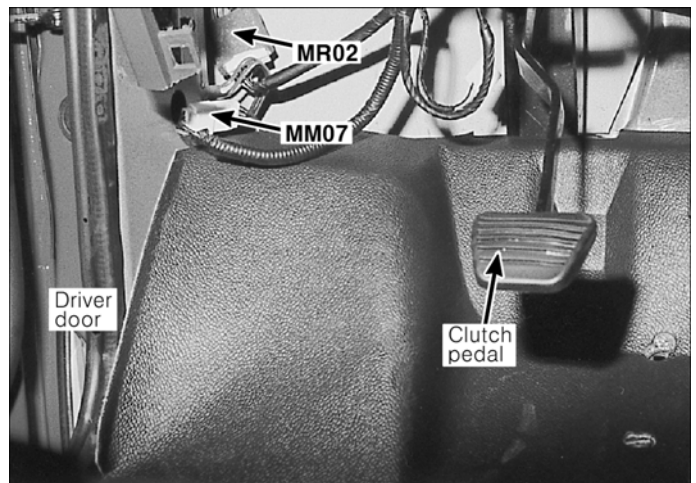

E3QD0A1D

MI01

MM07, MR02

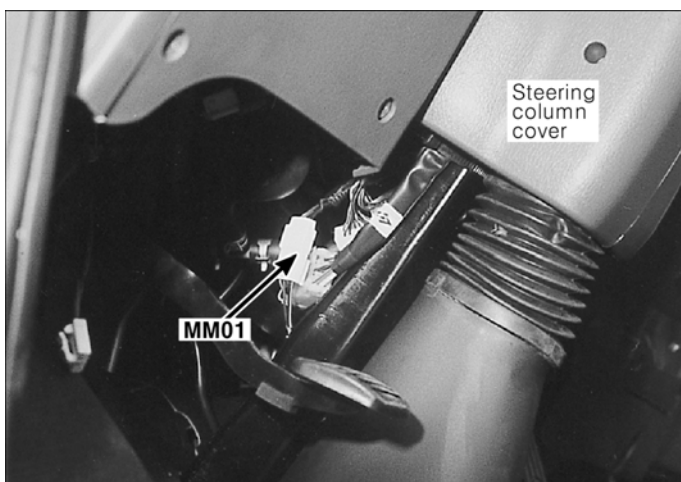

E3QD0A1B

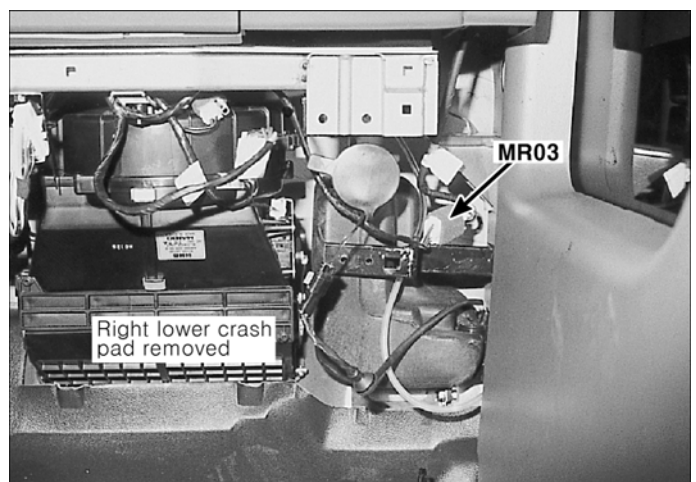

E3QD0A1E

MM01

MR03

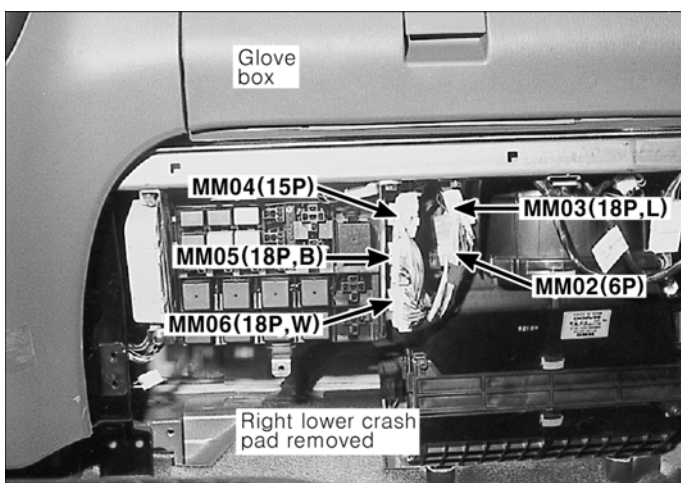

E3QD0A1C

MM02, MM03, MM04, MM05, MM06

UNDER FLOOR HARNESS

E4A31BD2

UNDER FLOOR HARNESS (1)

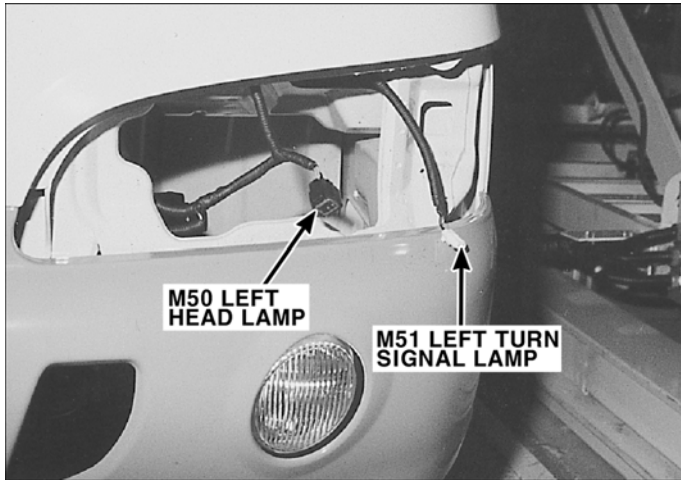

E3QD002A

M50, M51

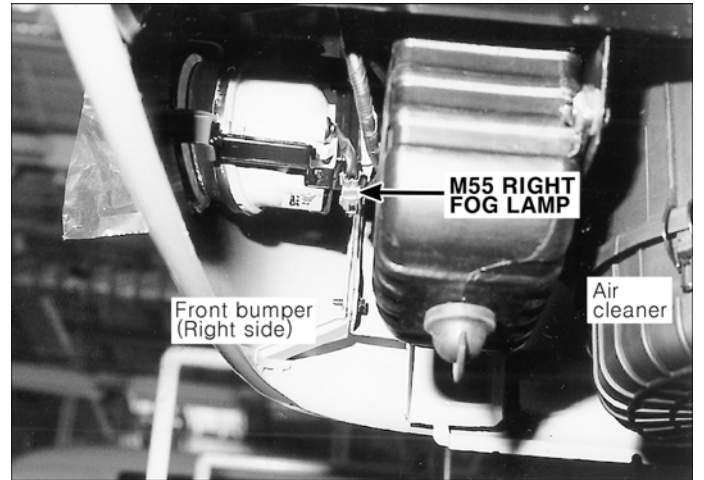

E3QD002D

M55

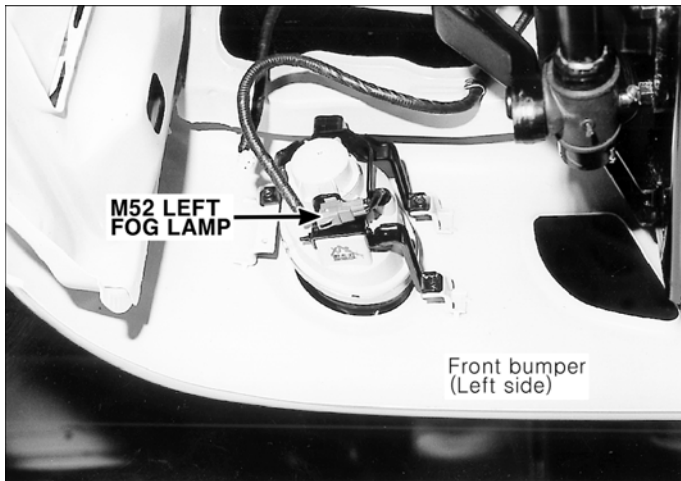

E3QD002B

M52



E3QD002E

M57

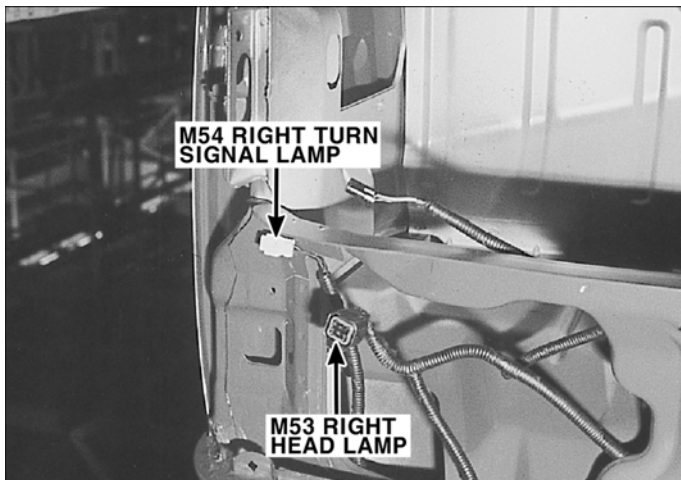

E3QD002C

M53, M54

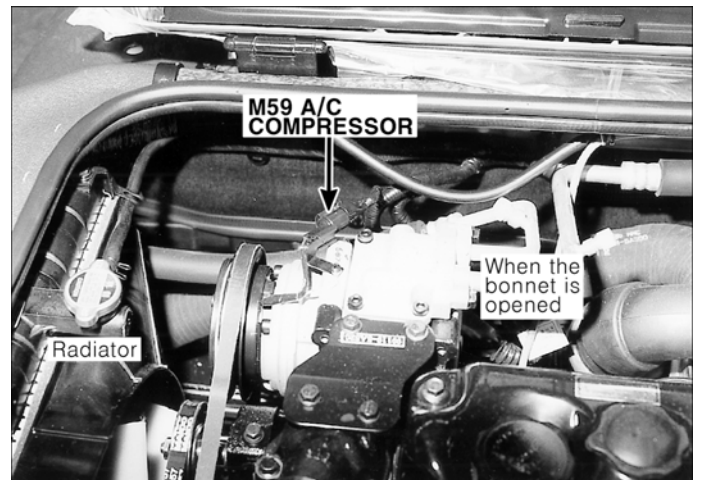

E3QD002F

M59

UNDER FLOOR HARNESS (2)

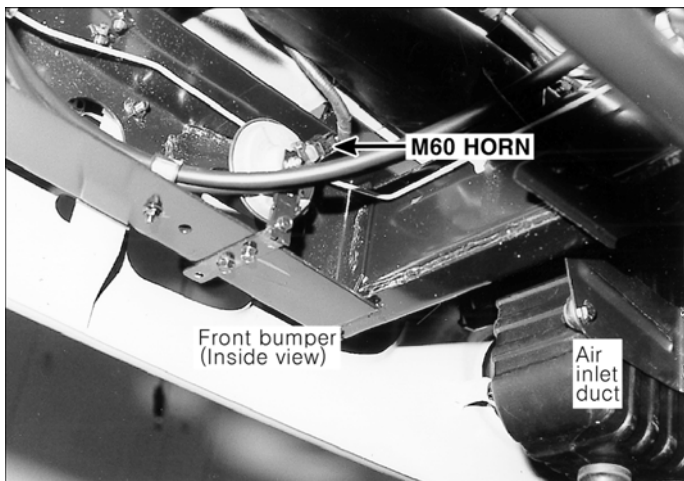

E3QD002G

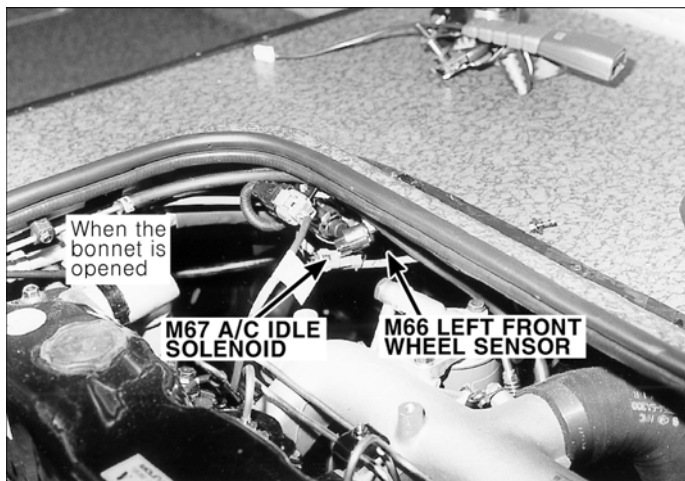

E3QD002K

M60

M66, M67

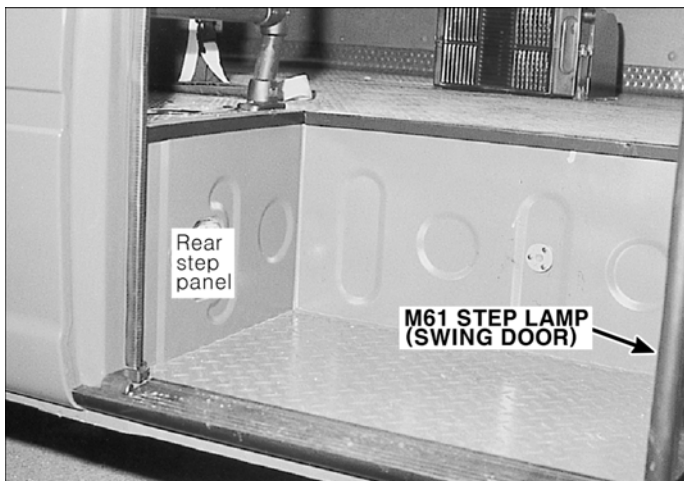

E3QD002H

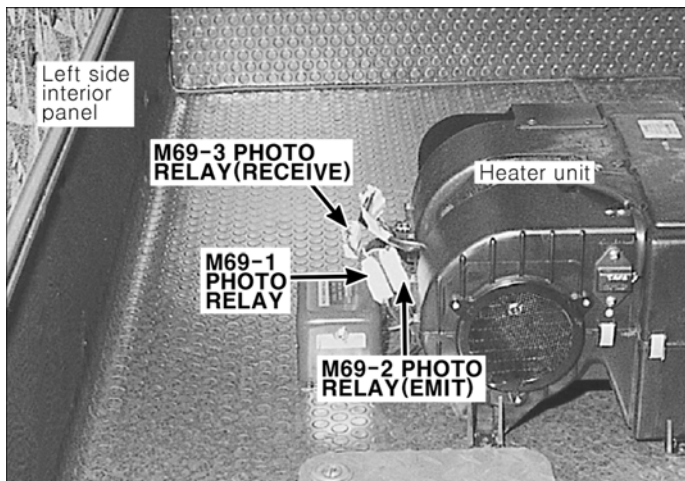

E3QD002L

M61

M69-1, M69-2, M69-3

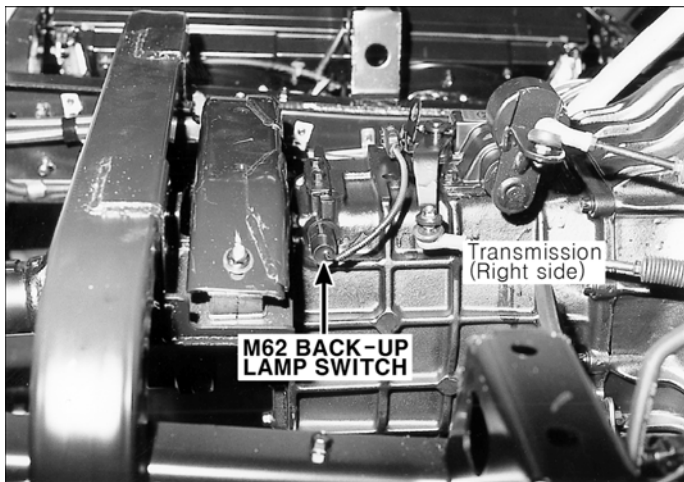

E3QD002J

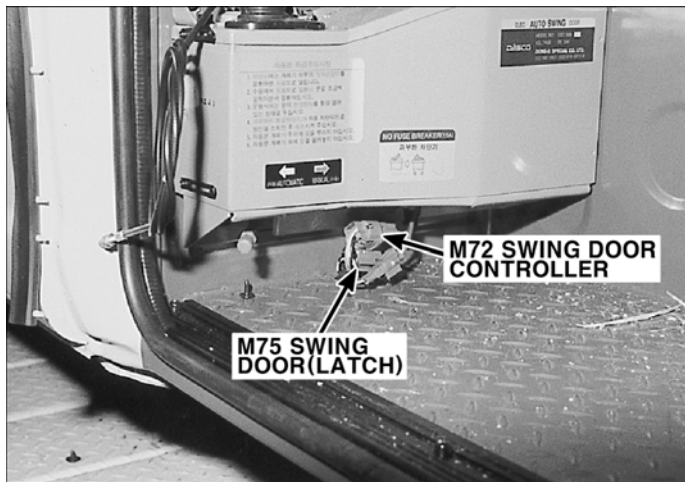

E3QD002M

M62

M72, M75

UNDER FLOOR HARNESS (3)

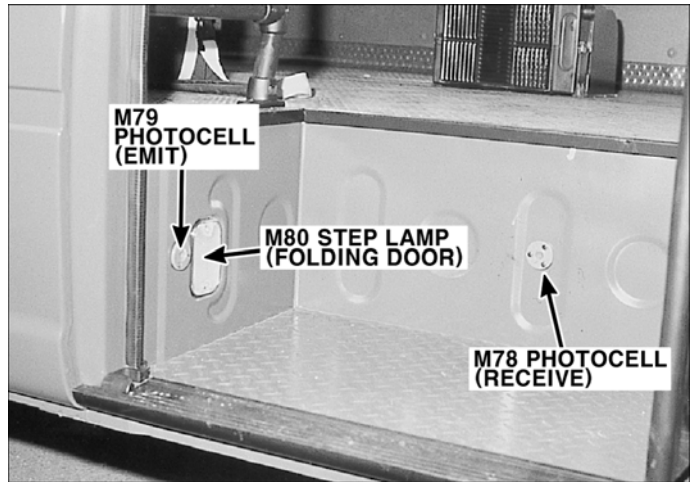
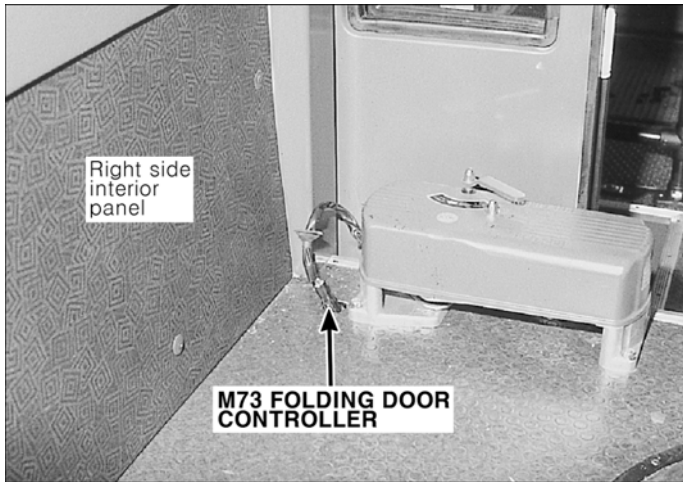

M73

M78, M79, M80

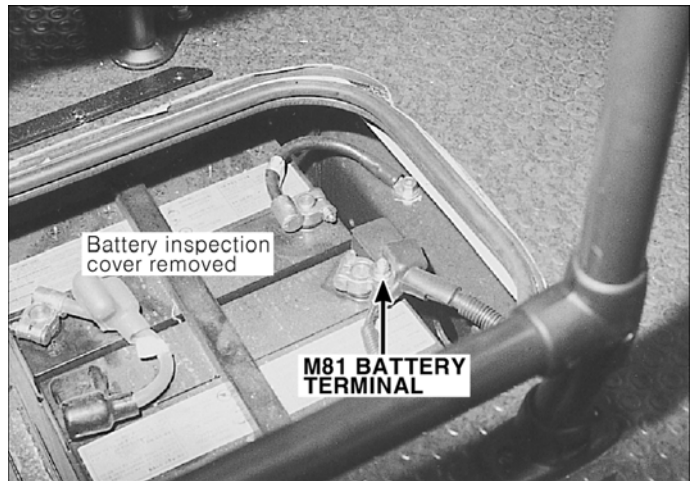
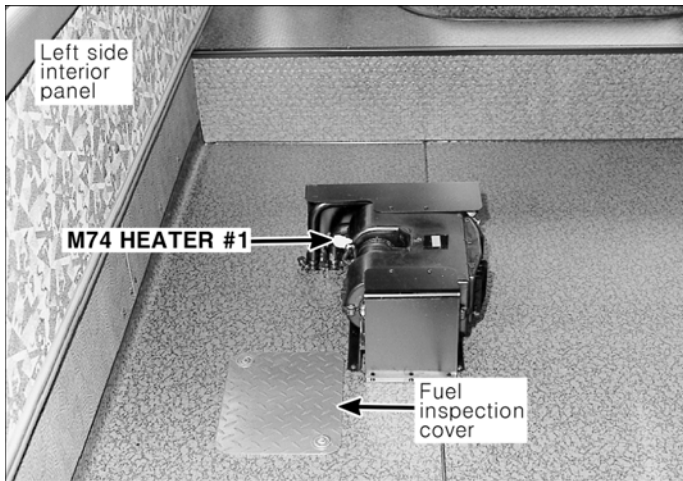

M74

M81

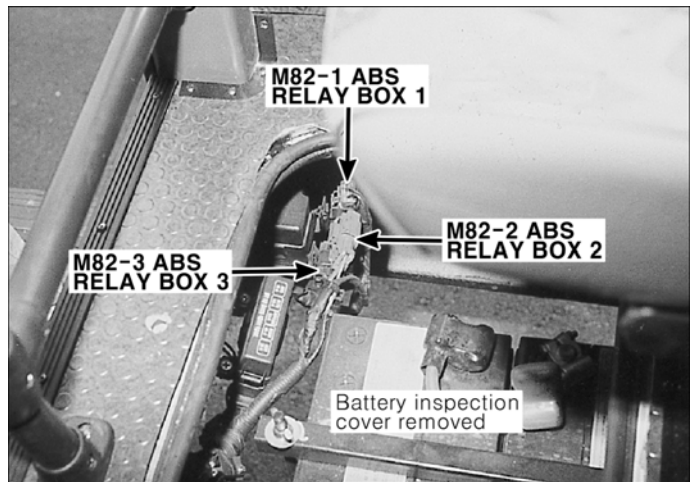
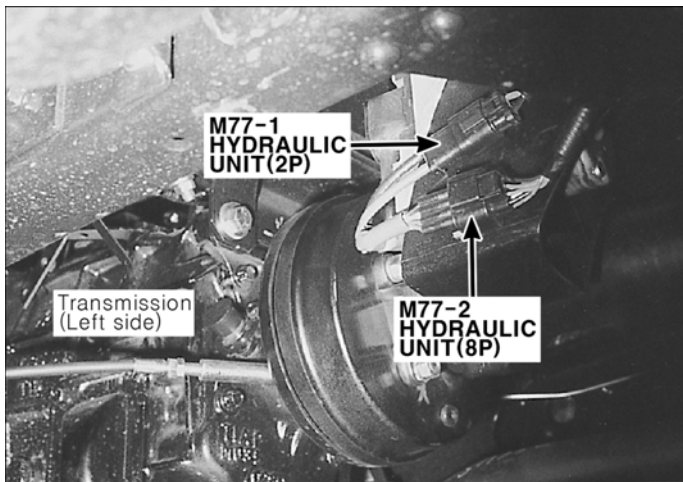

M77-1, M77-2

M82-1, M82-2, M82-3

UNDER FLOOR HARNESS (4)

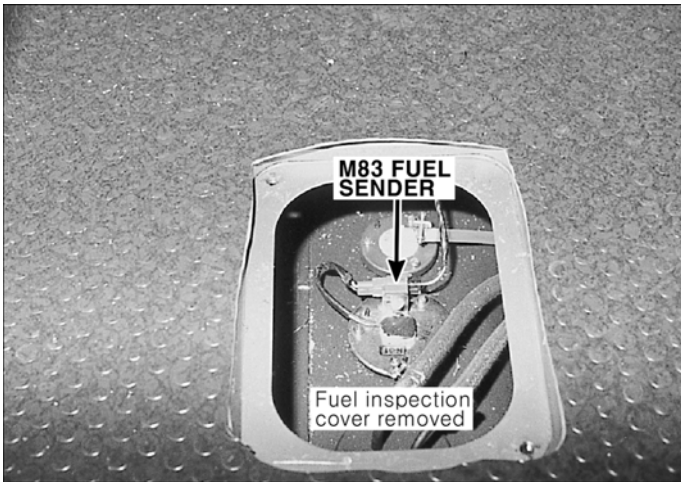

E3QD002U

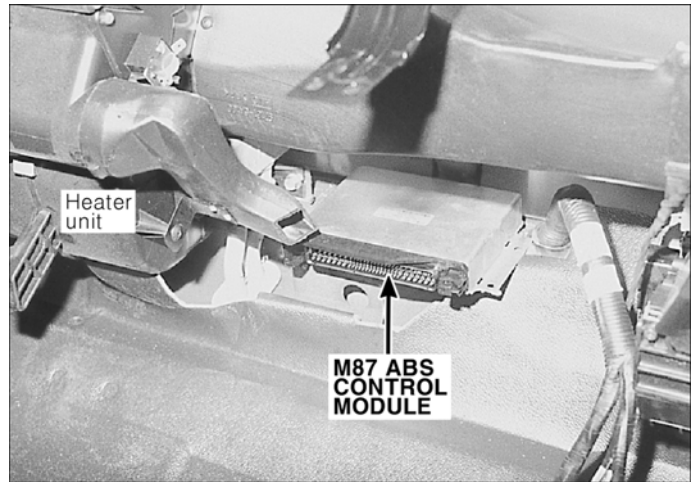

E3QD002X

M83

M87

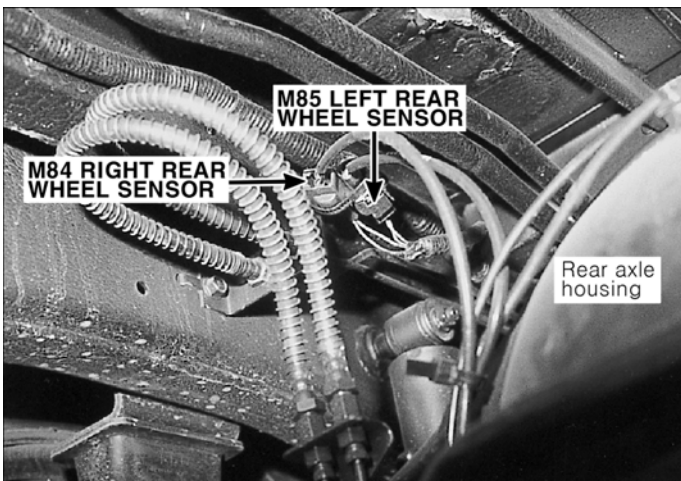

E3QD002V

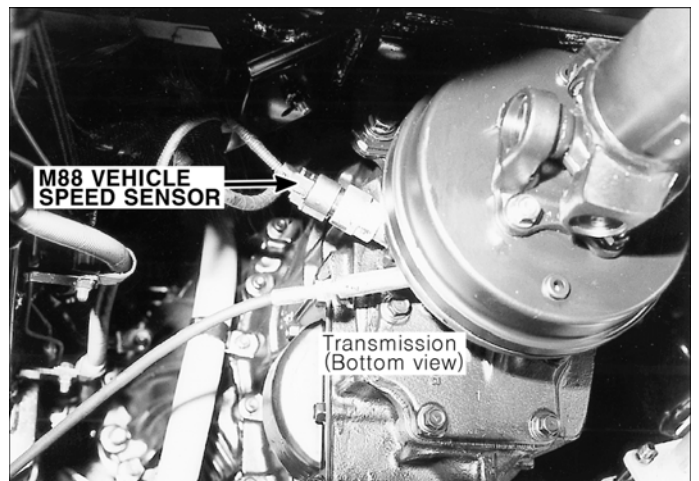

E3QD002Y

M84, M85

M88

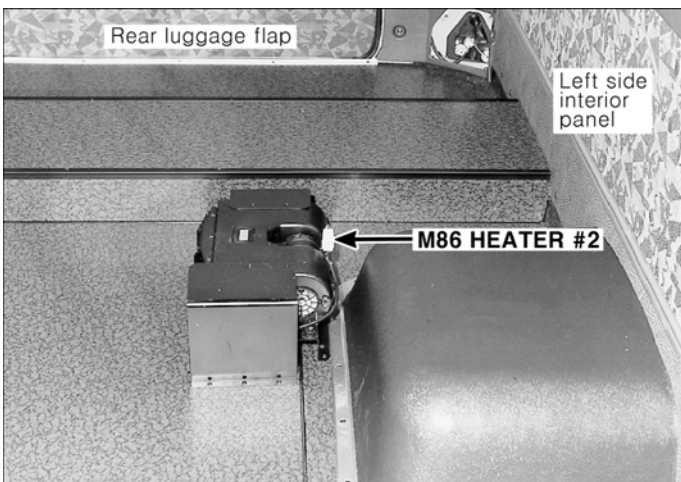

E3QD002W

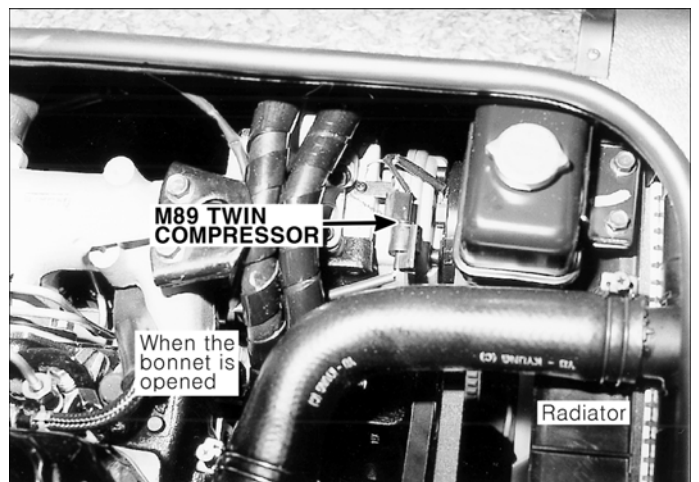

E3QD002Z

M86

M89

UNDER FLOOR HARNESS (5)



E3QD0A2A

M105

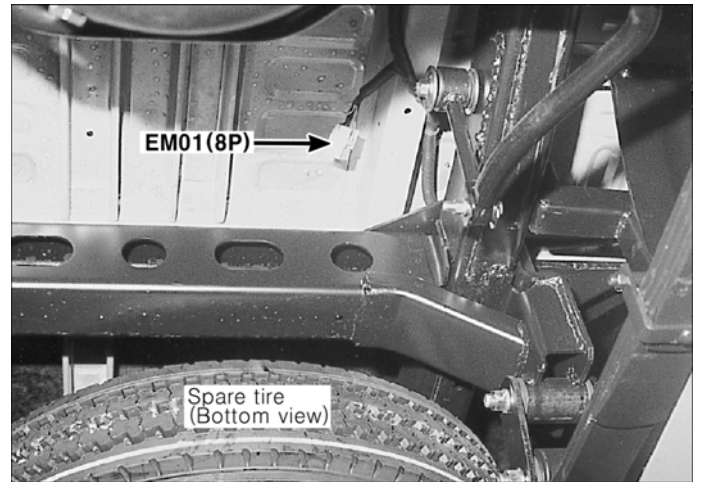

E3QD0A2D

EM01

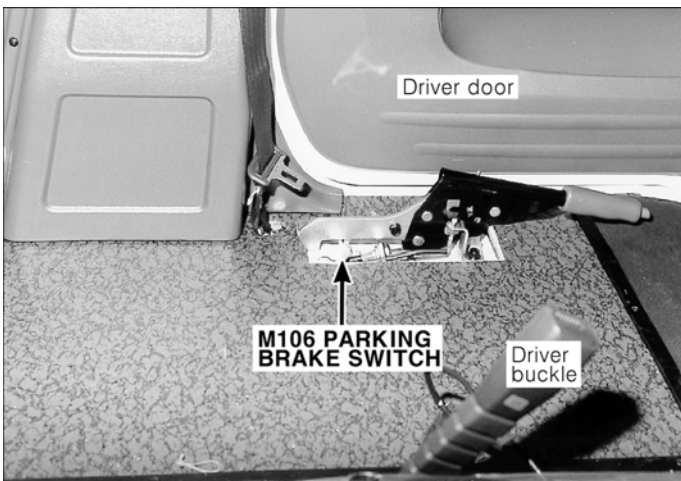

E3QD0A2B

M106

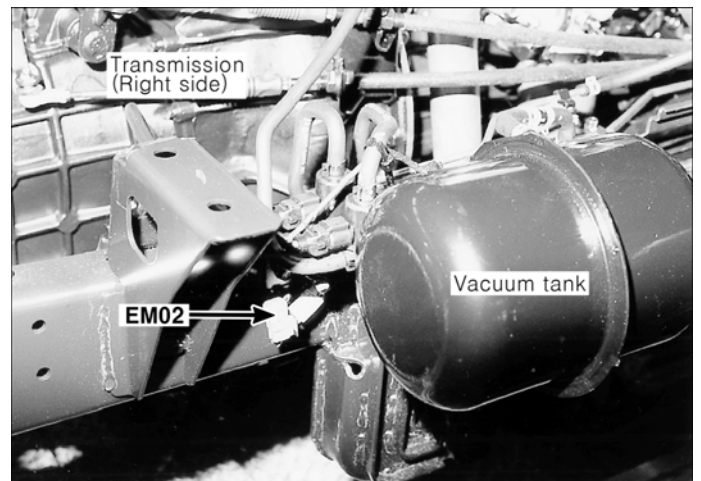

E3QD0A2E

EM02



E3QD0A2C

M107

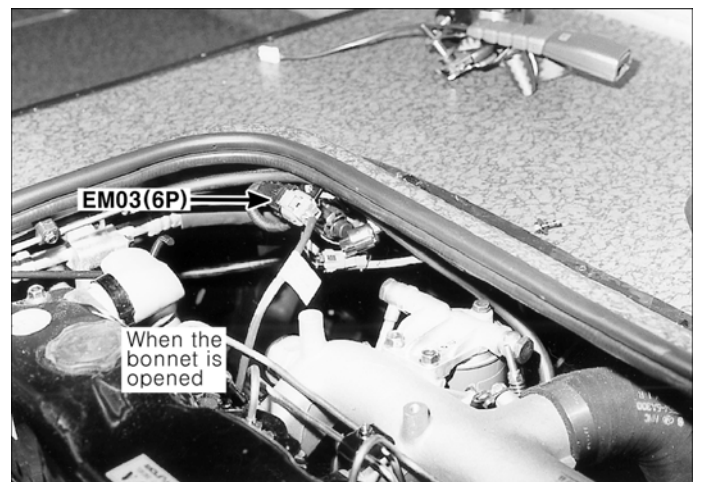

E3QD0A2F

EM03

UNDER FLOOR HARNESS (6)

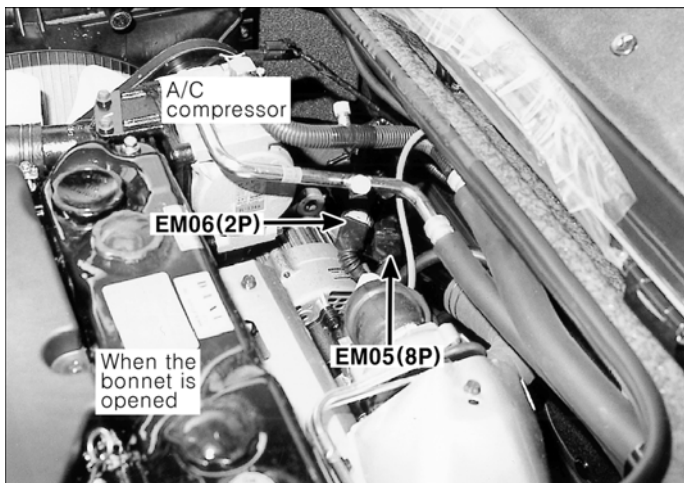

E3QD0A2G

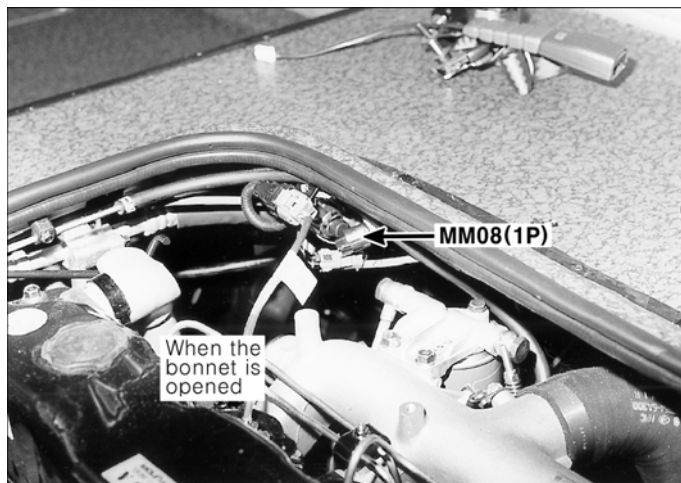

E3QD0A2K

EM05, EM06

MM08

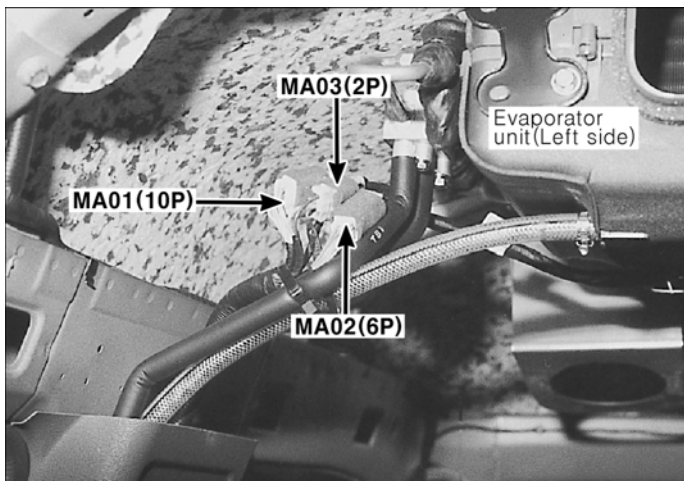

E3QD0A2H

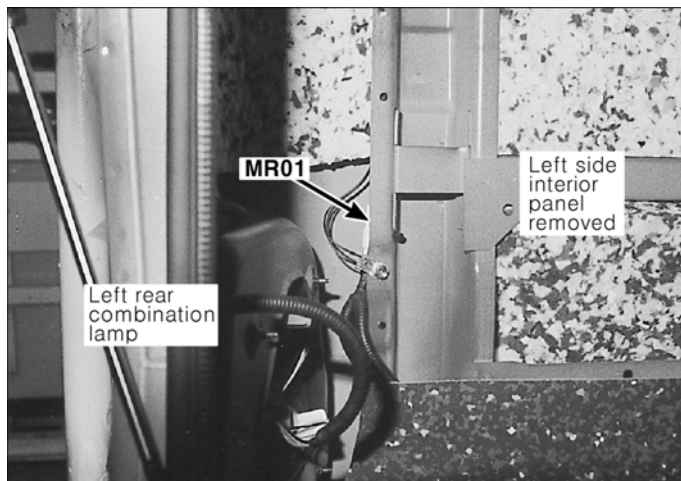

E3QD0A2L

MA01, MA02, MA03

MR01

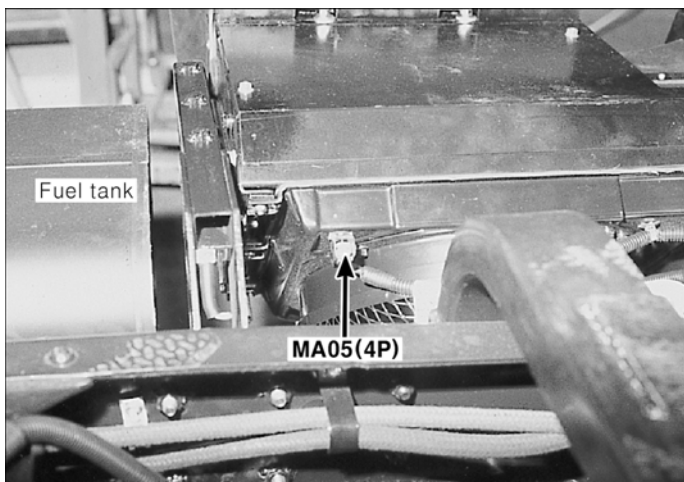

E3QD0A2J

MA05

ENGINE HARNESS

EBD3E093

ENGINE HARNESS (1)

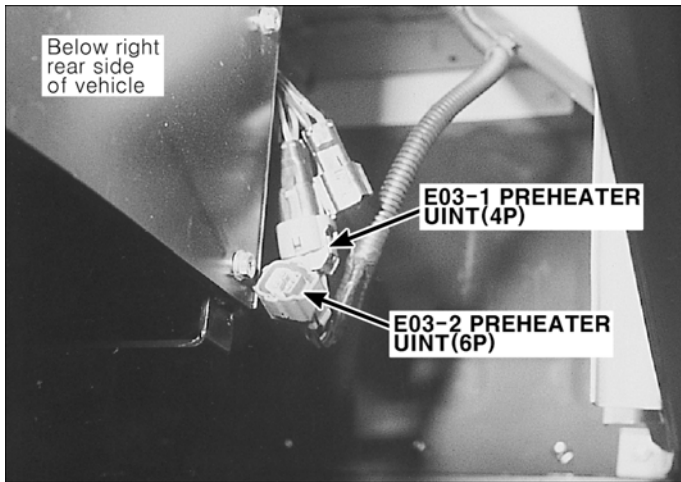

E3QD003A

E03-1, E03-2

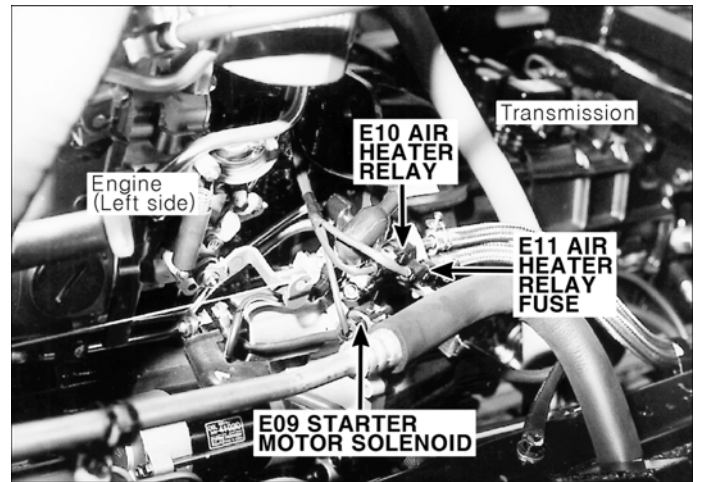

E3QD003D

E09, E10, E11

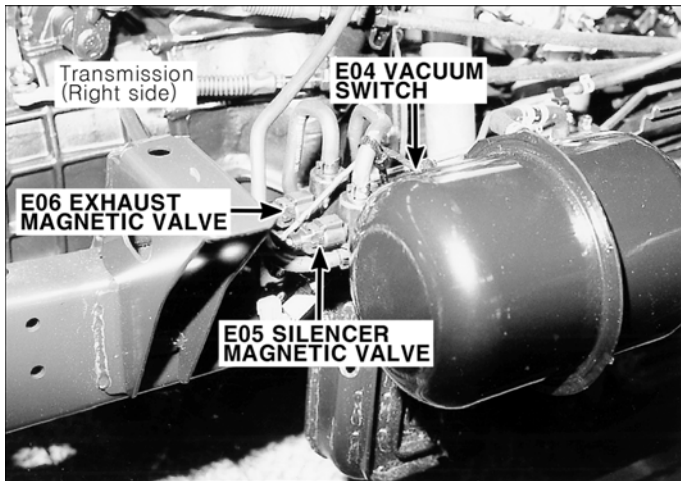

E3QD003B

E04, E05, E06

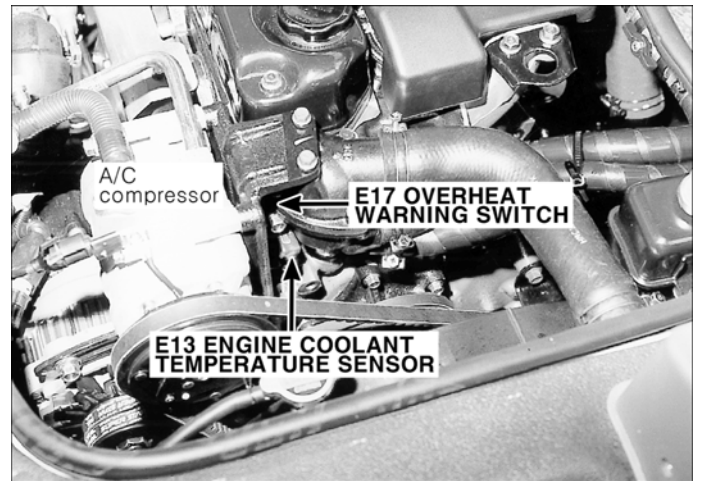

E3QD003E

E13, E17

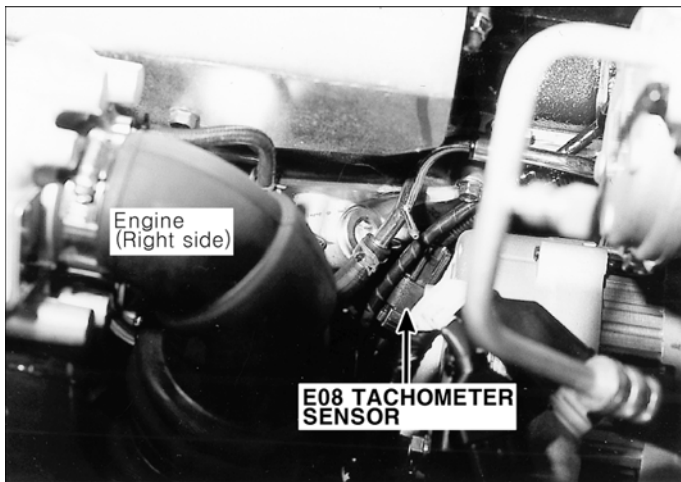

E3QD003C

E08

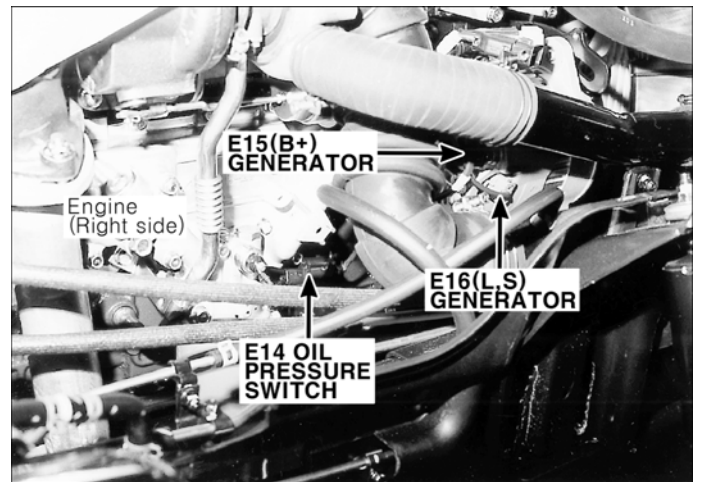

E3QD003F

E14, E15, E16

A/C HARNESS EBEEB637

A/C HARNESS (1)

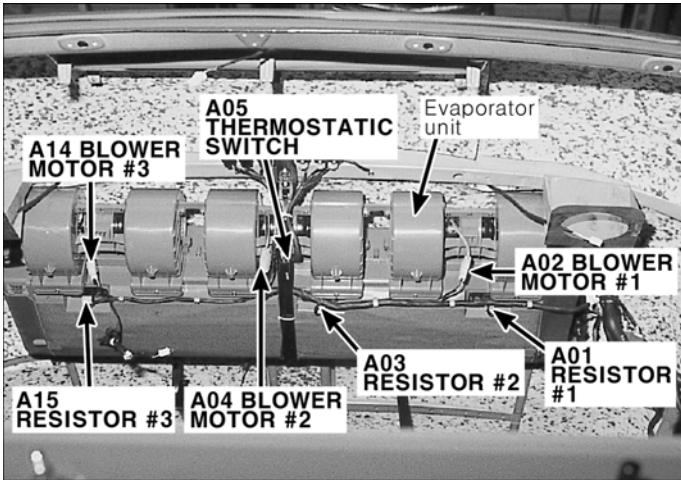

E3QD004A

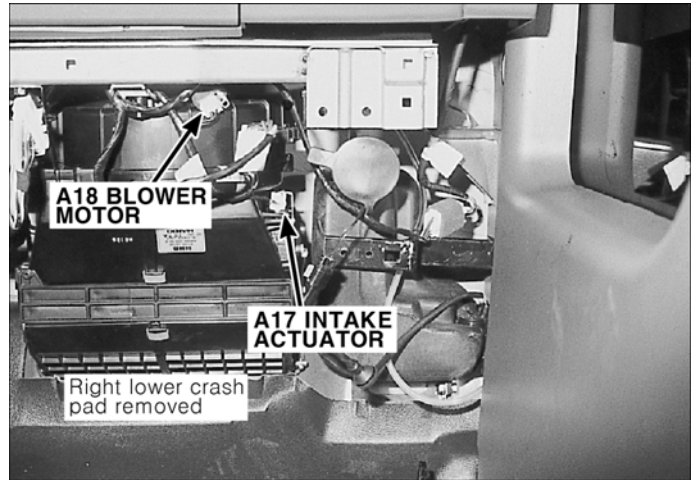

E3QD004D

A01, A02, A03, A04, A05, A14, A15

A17, A18

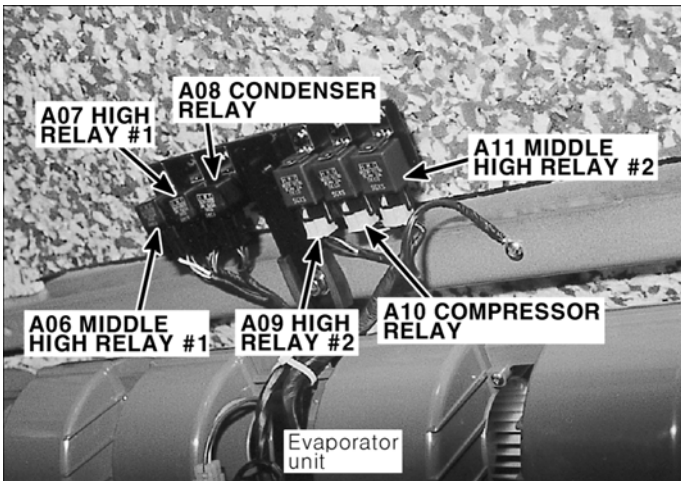

E3QD004B

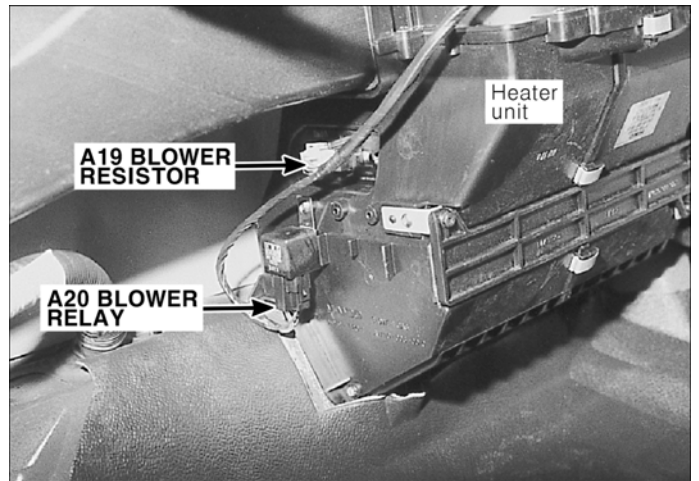

E3QD004E

A06, A07, A08, A09, A10, A11

A19, A20

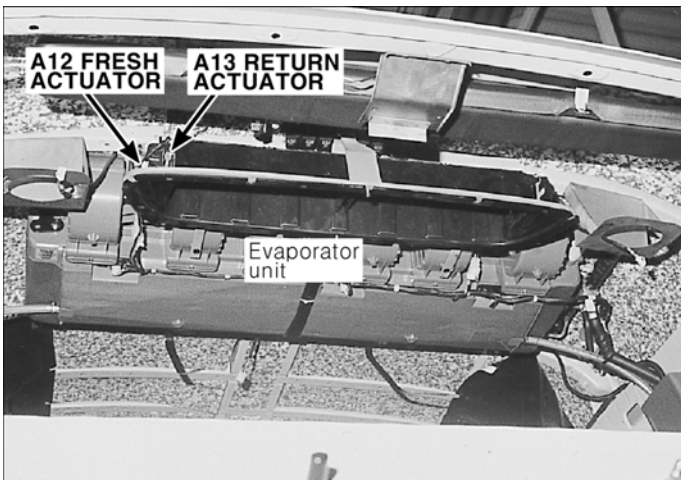

E3QD004C

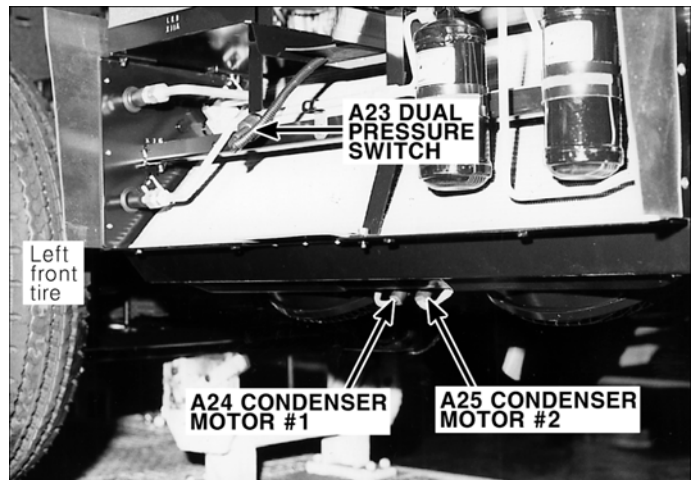

E3QD004F

A12, A13

A23, A24, A25

FACIA & DOOR HARNESS

E7AB0FF4

FACIA & DOOR HARNESS (1)

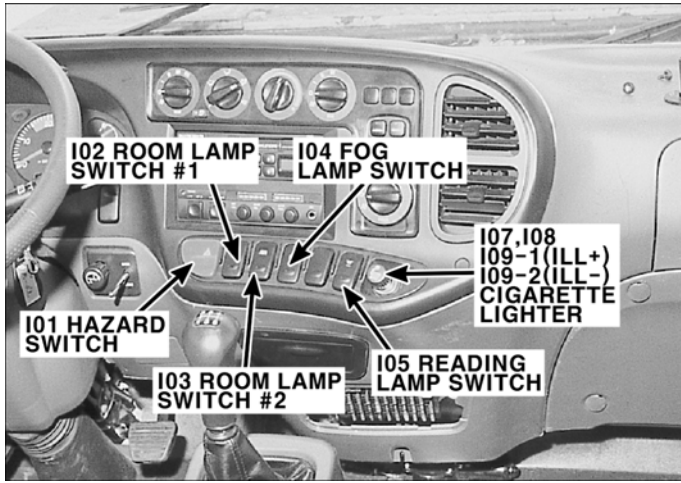

E3QD005A



E3QD005C

I01, I02, I03, I04, I05, I07, I08, I09-1,2

D01

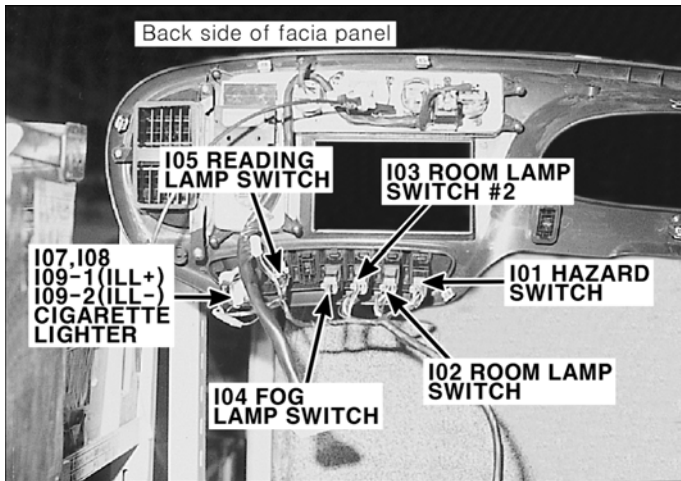

E3QD005B

I01, I02, I03, I04, I05, I07, I08, I09-1,2

REAR BODY & LICENSE HARNESS

EE09EC7E

REAR BODY & LICENSE HARNESS (1)

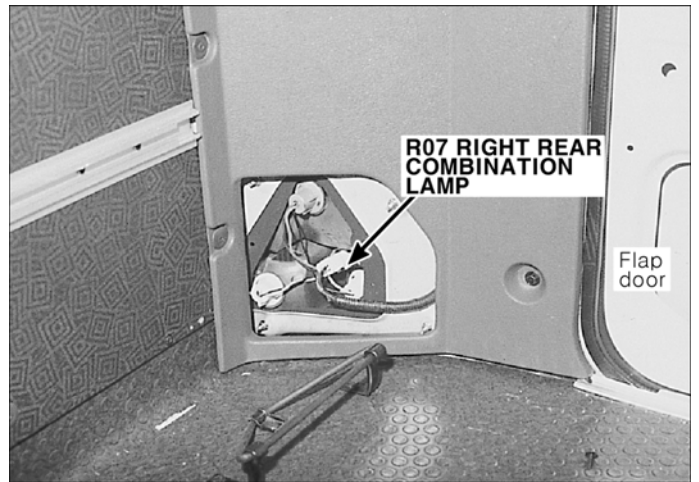
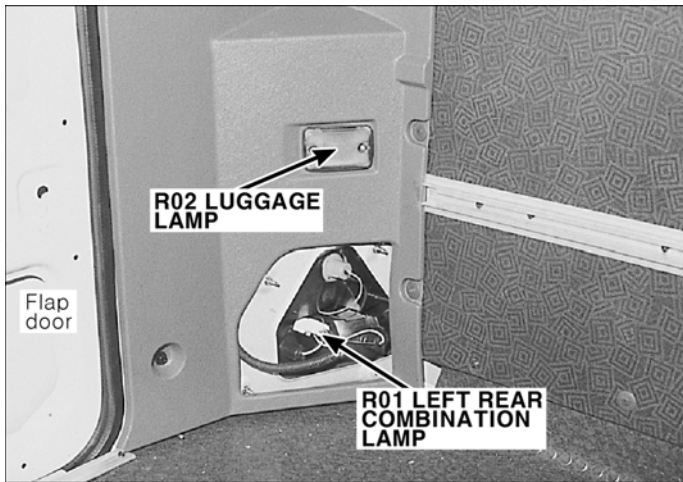

R01, R02

R07

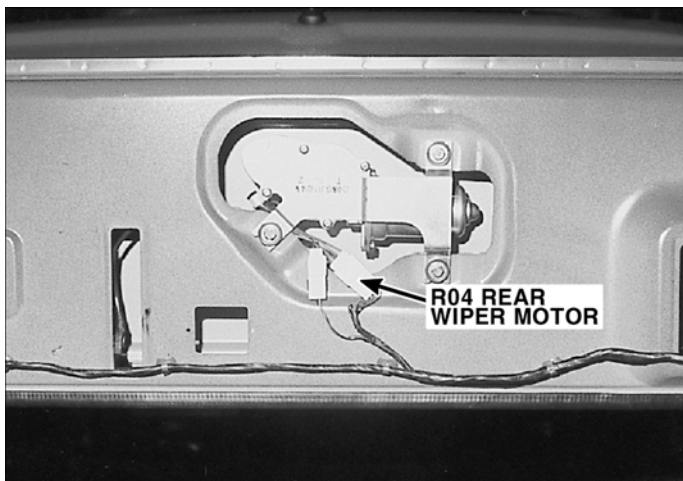

R04

R08, R09

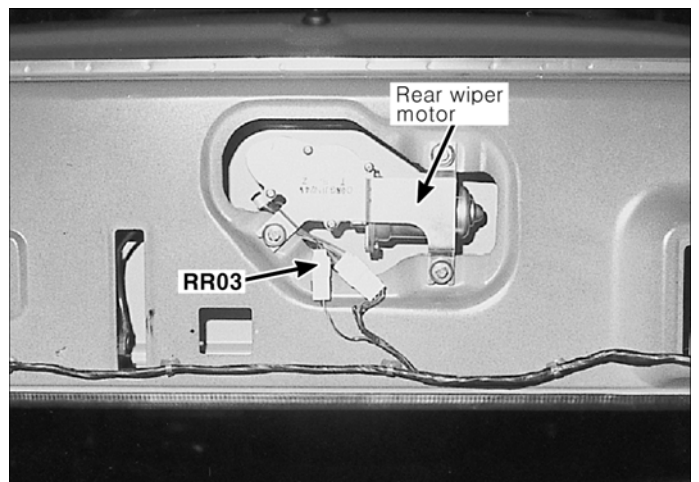
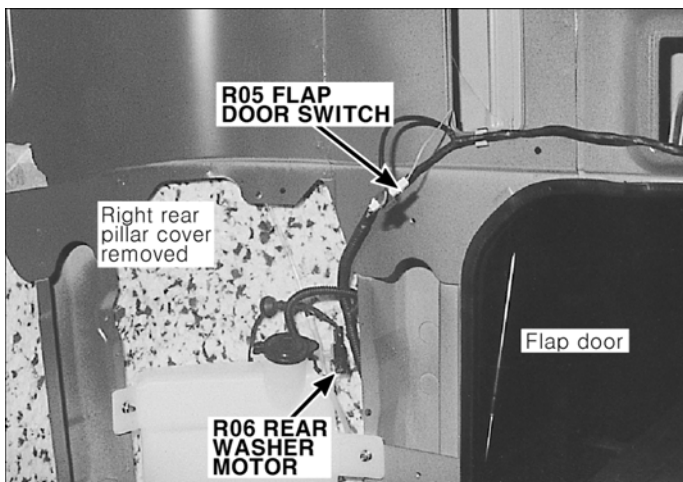

R05, R06

RR03

ROOM LAMP & SPEAKER HARNESS

E8D4E061

ROOM LAMP & SPEAKER HARNESS (1)

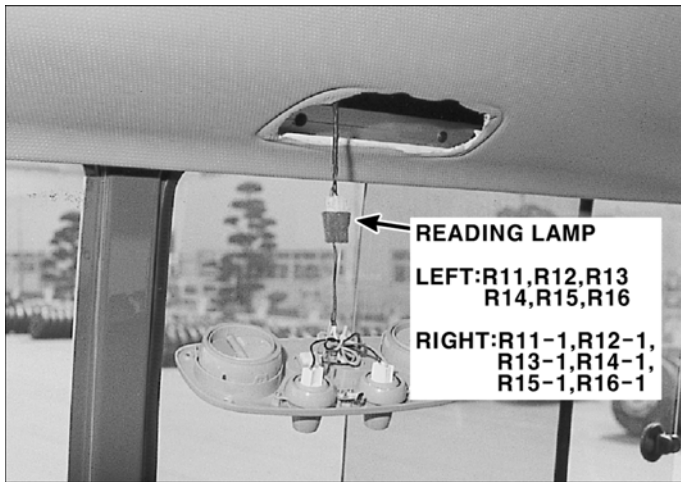

E3QD007A

R11~R16-1

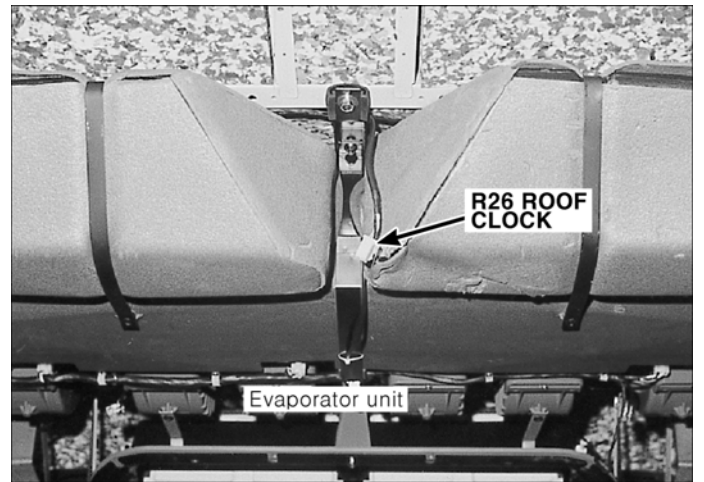

E3QD007D

R26

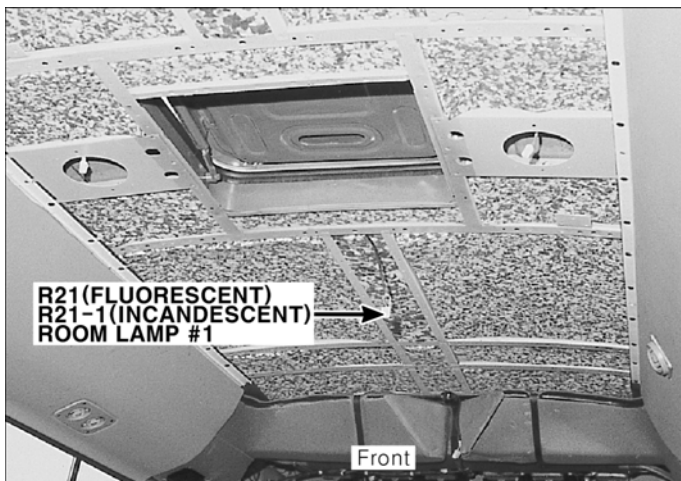

E3QD007B

R21, R21-1

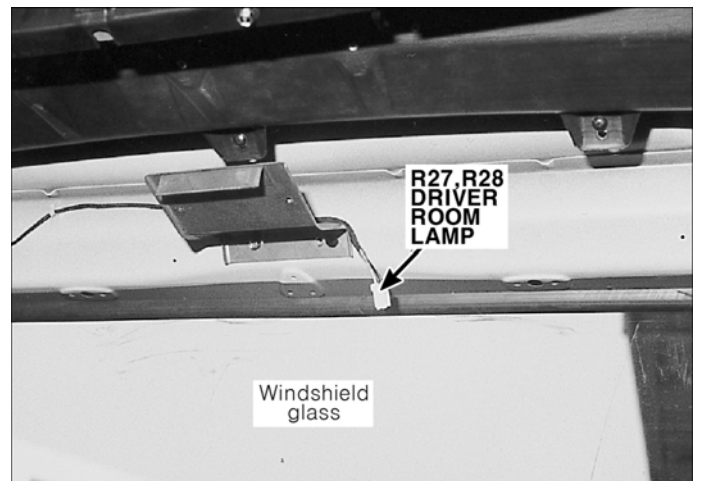

E3QD007E

R27, R28

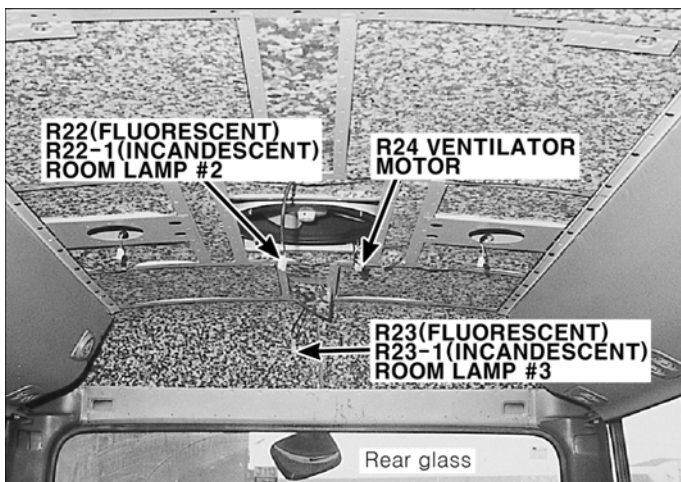

E3QD007C

R22, R22-1, R23, R23-1, R24

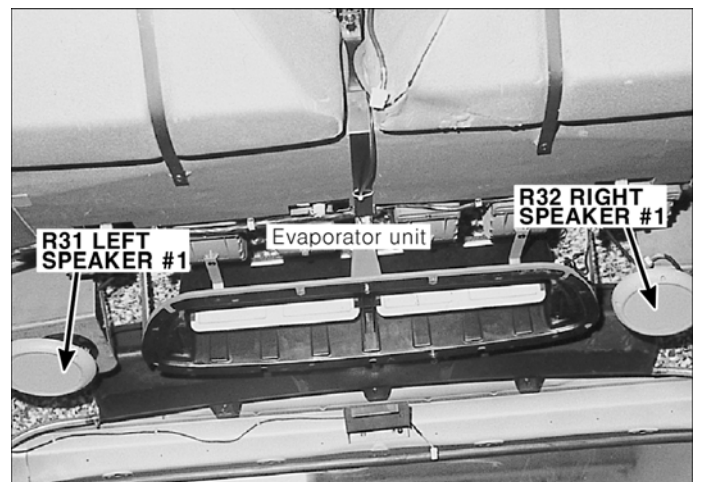

E3QD007F

R31, R32

ROOM LAMP & SPEAKER HARNESS (2)

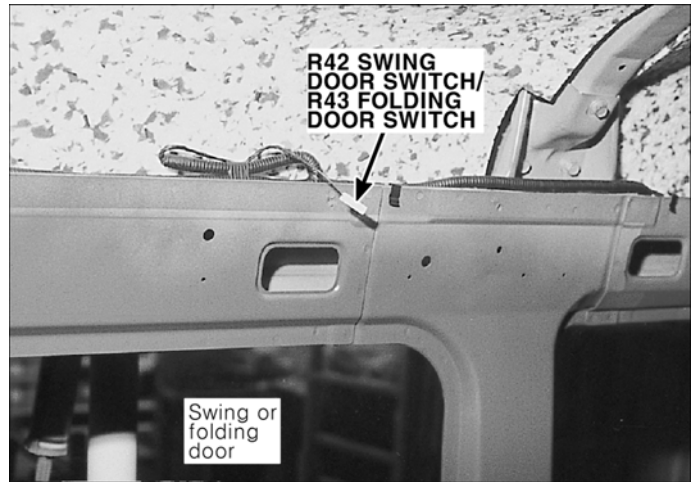
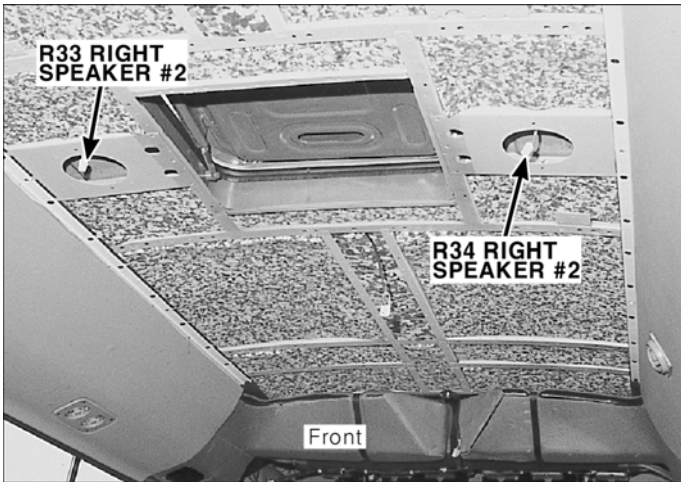

R33, R34

R42, R43

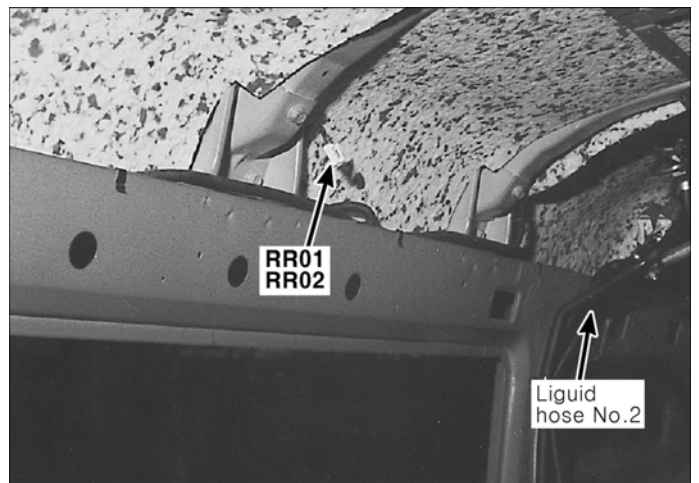
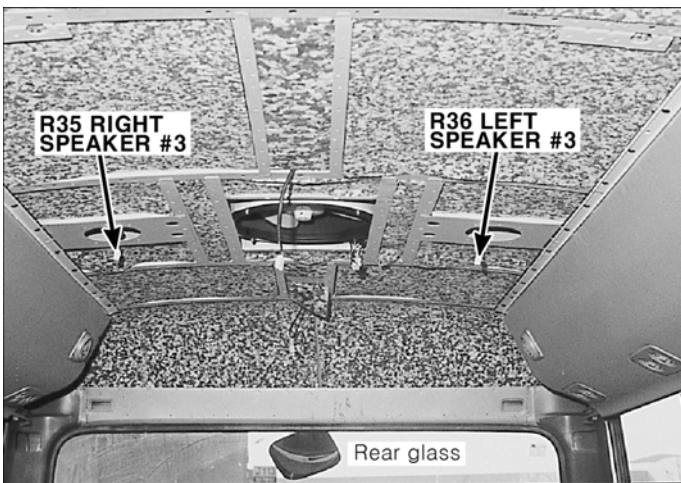

R35, R36

RR01, RR02

GROUNDS EBC721BC

GROUNDS (1)

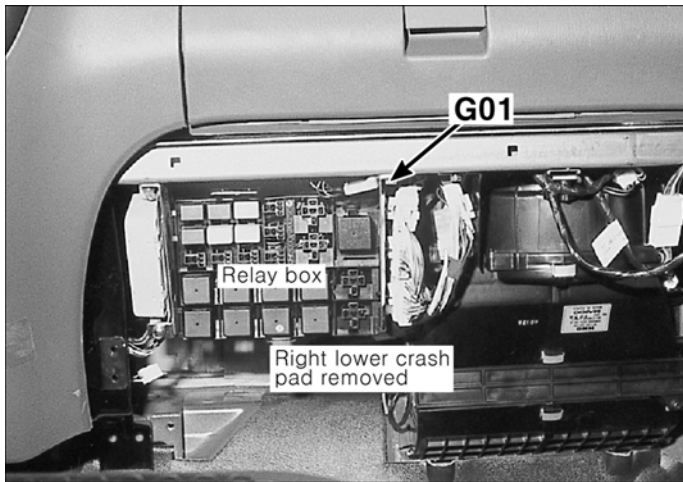

E3QD008A

G01

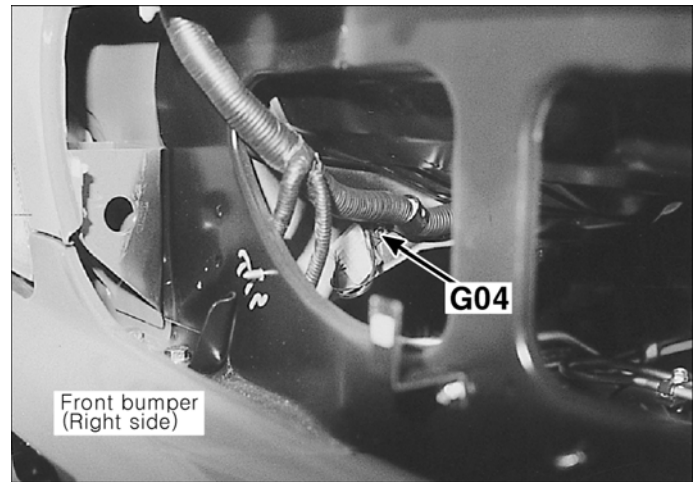

E3QD008D

G04

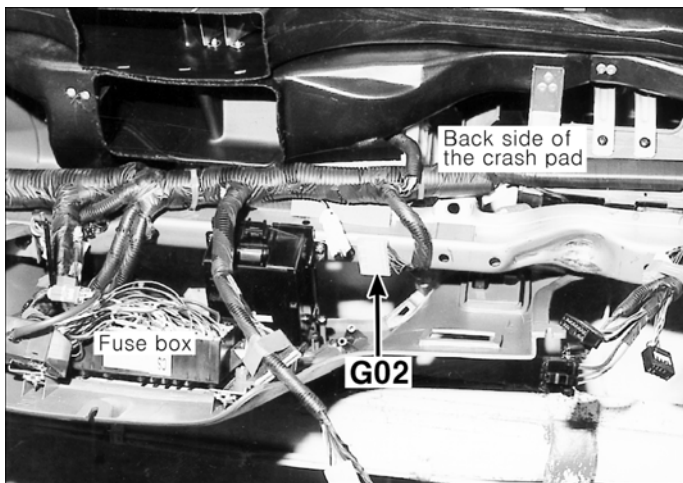

E3QD008B

G02

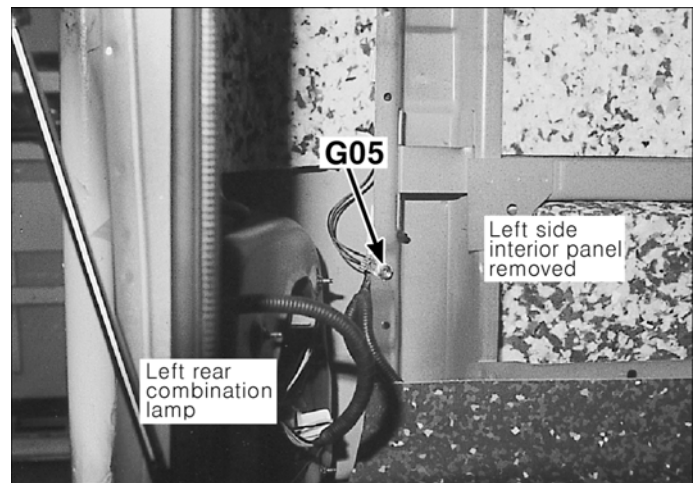

E3QD008E

G05

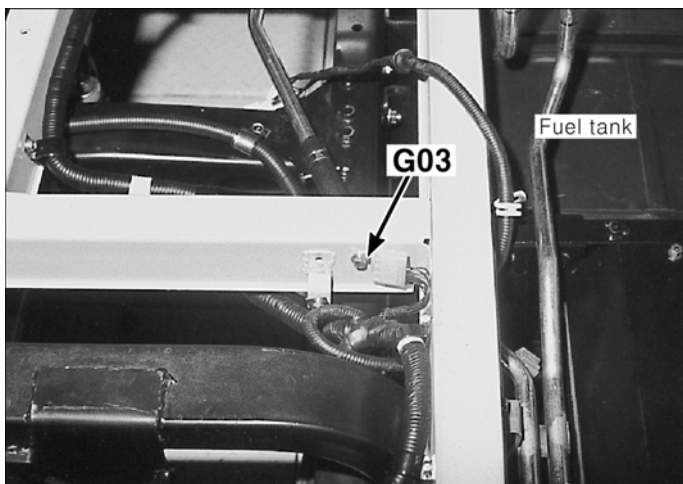

E3QD008C

G03

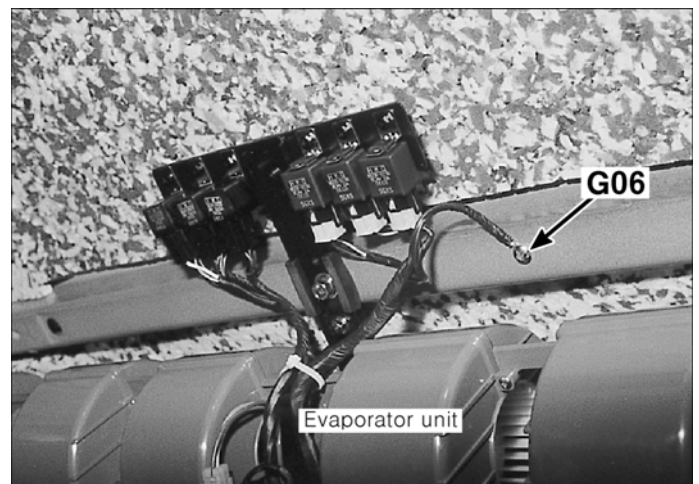

E3QD008F

G06

DIODES E01DD93B

DIODES (1)

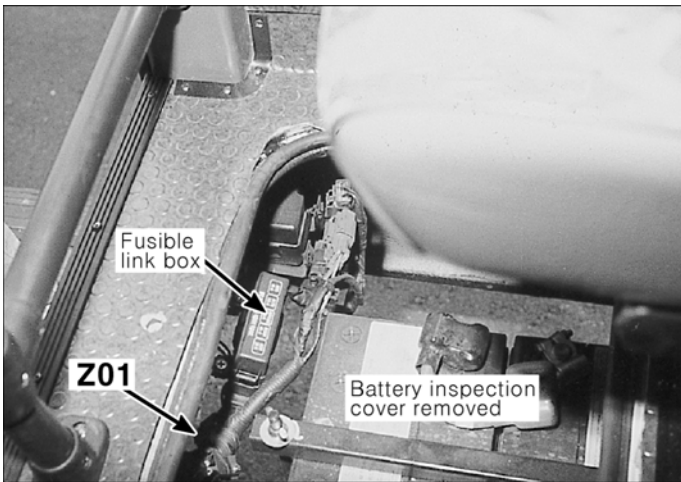

E3QD009A

Z01



E3QD009C

Z04, Z05, Z07, Z09

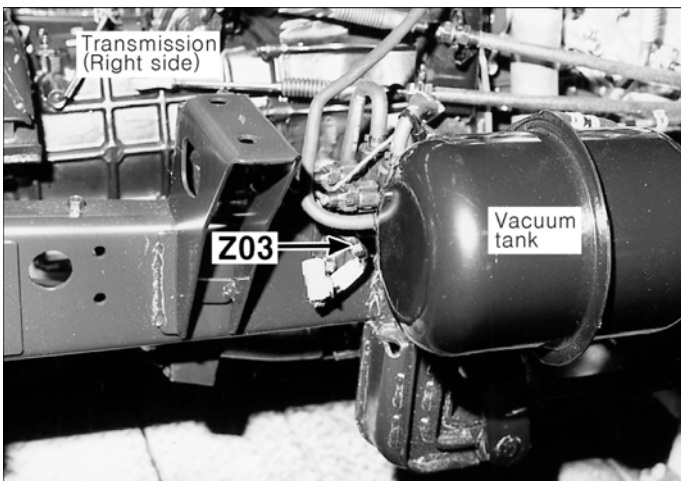

E3QD009B



Z03

Connector Configurations

MAIN HARNESS	CC- 2
UNDER FLOOR HARNESS	CC- 7
ENGIN HARNESS	CC-10
A/C HARNESS	CC-11
REAR BODY, LICENSE & REAR FOG LAMP HARNESS	CC-12
ROOM, READING & SPEAKER HARNESS	CC-13
FACIA & DOOR HARNESS	CC-15

MAIN HARNESS EEFEF303

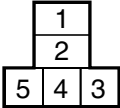
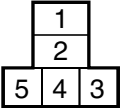
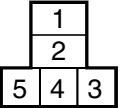
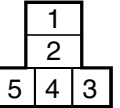
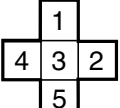
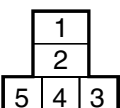
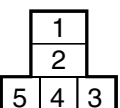
MAIN HARNESS (1)

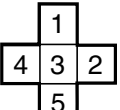
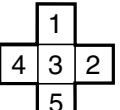
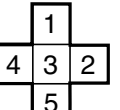
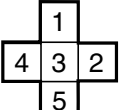
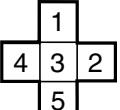
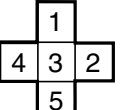
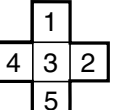
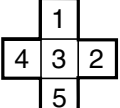
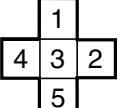
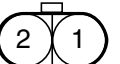
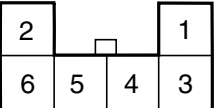
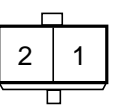
<p>M01</p>  <p>CR05F011</p>	<p>M02</p>  <p>CR05F011</p>	<p>M03</p>  <p>CR05F011</p>	<p>M04</p>  <p>CR05F011</p>
<p>M05</p>  <p>CR05F019</p>	<p>M06</p>  <p>CR05F011</p>	<p>M07</p>  <p>CR05F011</p>	<p>BLANK</p>
<p>M08</p>  <p>CR03F103</p>	<p>M09</p>  <p>CR05F019</p>	<p>M10</p>  <p>CR05F019</p>	<p>M11</p>  <p>CR05F019</p>
<p>M12</p>  <p>CR05F019</p>	<p>M13</p>  <p>CR05F019</p>	<p>M14</p>  <p>CR05F019</p>	<p>M15</p>  <p>CR05F019</p>
<p>M16</p>  <p>CR05F019</p>	<p>M17</p>  <p>CR05F019</p>	<p>BLANK</p>	<p>M20</p>  <p>CR02F001</p>
<p>BLANK</p>	<p>BLANK</p>	<p>M22</p>  <p>CR06F017</p>	<p>M23</p>  <p>CR02F049</p>

MAIN HARNESS (2)

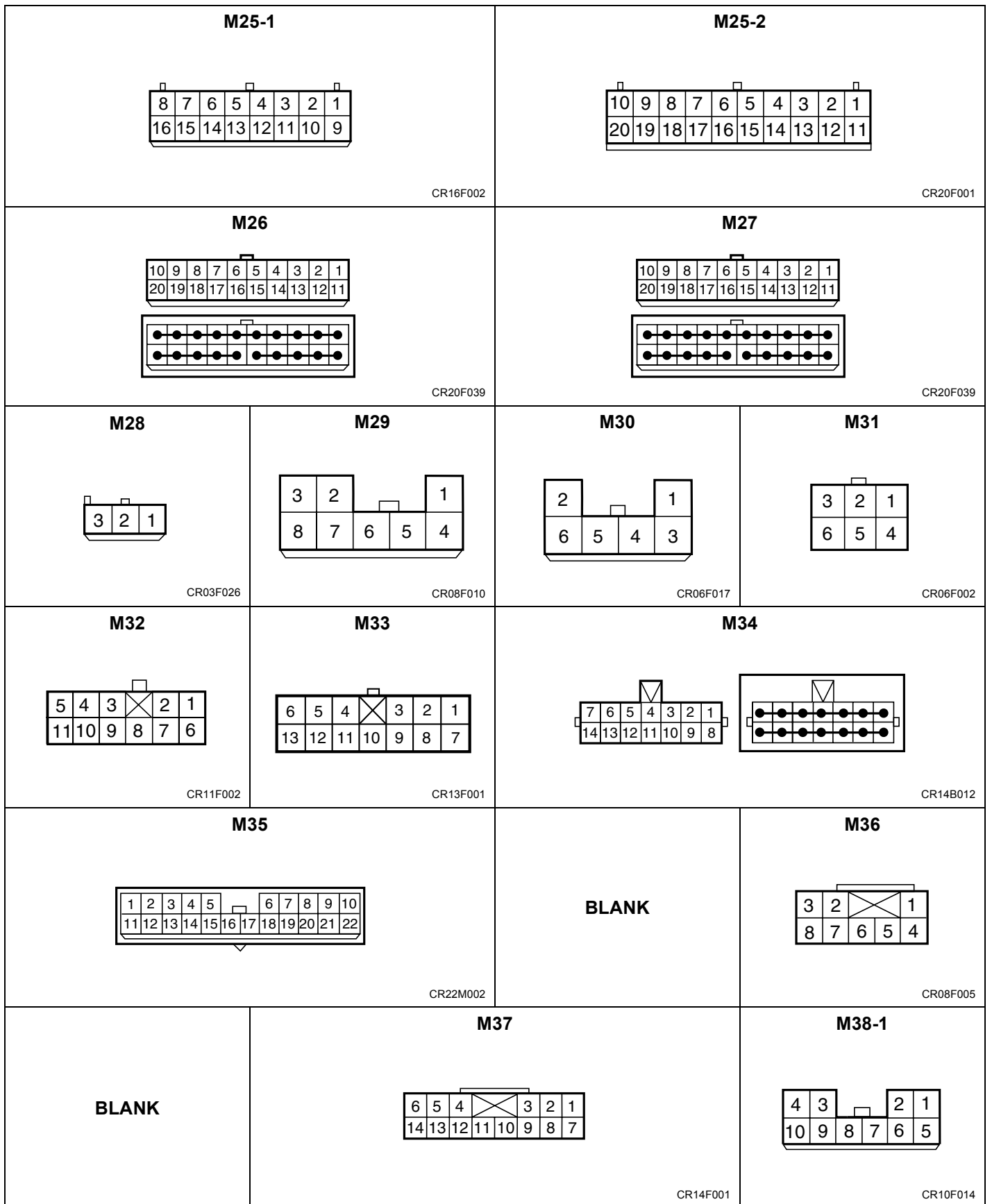

MAIN HARNESS (3)

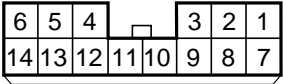
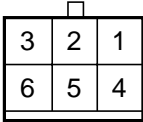
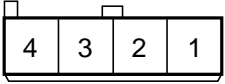
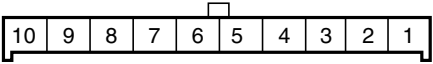
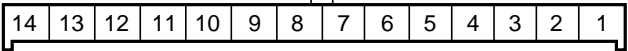
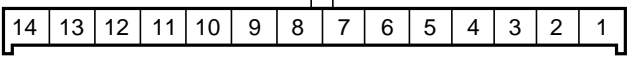
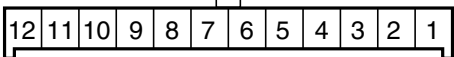
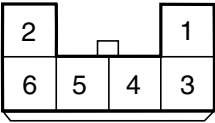
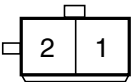
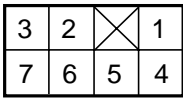
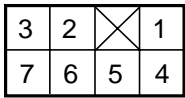
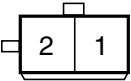
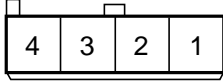
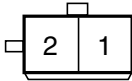
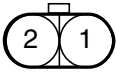
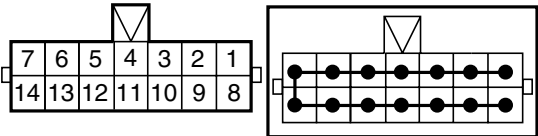
<p style="text-align: center;">M38-2</p>  <p style="text-align: right;">CR14F019</p>	<p style="text-align: center;">M39</p>  <p style="text-align: right;">CR06F014</p>	<p style="text-align: center;">M40</p>  <p style="text-align: right;">CR04F048</p>		
<p style="text-align: center;">M41-1</p>  <p style="text-align: right;">CR10F005</p>	<p style="text-align: center;">M41-2</p>  <p style="text-align: right;">CR14F007</p>			
<p style="text-align: center;">M41-3</p>  <p style="text-align: right;">CR14F007</p>	<p style="text-align: center;">M41-4</p>  <p style="text-align: right;">CR12F001</p>			
<p style="text-align: center;">M42</p>  <p style="text-align: right;">CR06F017</p>	<p style="text-align: center;">M43</p>  <p style="text-align: right;">CR02F046</p>	<p style="text-align: center;">M44</p>  <p style="text-align: right;">CR07F002</p>	<p style="text-align: center;">M45</p>  <p style="text-align: right;">CR07F002</p>	
<p style="text-align: center;">M46</p>  <p style="text-align: right;">CR02F046</p>	<p style="text-align: center;">BLANK</p>		<p style="text-align: center;">M47</p>  <p style="text-align: right;">CR04F048</p>	<p style="text-align: center;">M48</p>  <p style="text-align: right;">CR02F046</p>
<p style="text-align: center;">BLANK</p>		<p style="text-align: center;">M49</p>  <p style="text-align: right;">CR02F001</p>	<p style="text-align: center;">M90</p>  <p style="text-align: right;">CR14B019</p>	

MAIN HARNESS (4)

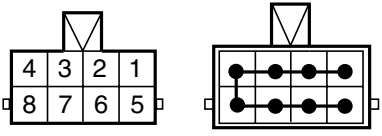
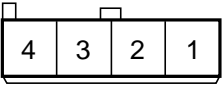
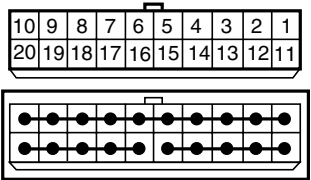
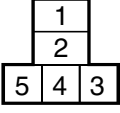
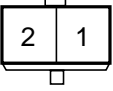
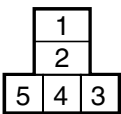
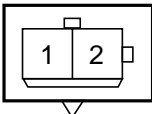
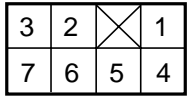
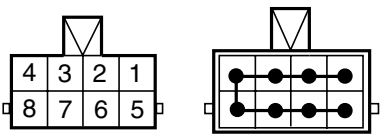
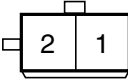
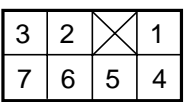
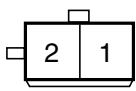
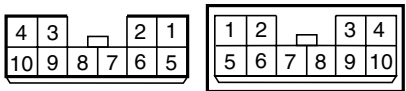
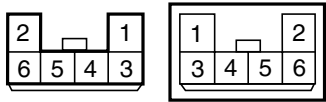
<p style="text-align: center;">M91</p>  <p style="text-align: right; font-size: small;">CR08B015</p>	<p style="text-align: center;">BLANK</p>	<p style="text-align: center;">M92</p>  <p style="text-align: right; font-size: small;">CR04F048</p>	
<p style="text-align: center;">M93</p>  <p style="text-align: right; font-size: small;">CR20F039</p>	<p style="text-align: center;">M94</p>  <p style="text-align: right; font-size: small;">CR05F011</p>	<p style="text-align: center;">M95</p>  <p style="text-align: right; font-size: small;">CR02F049</p>	
<p style="text-align: center;">M96</p>  <p style="text-align: right; font-size: small;">CR05F011</p>	<p style="text-align: center;">M97</p>  <p style="text-align: right; font-size: small;">CR02M020</p>	<p style="text-align: center;">BLANK</p>	<p style="text-align: center;">M99</p>  <p style="text-align: right; font-size: small;">CR07F002</p>
<p style="text-align: center;">M100</p>  <p style="text-align: right; font-size: small;">CR08B015</p>	<p style="text-align: center;">M101</p>  <p style="text-align: right; font-size: small;">CR02F046</p>	<p style="text-align: center;">BLANK</p>	
<p style="text-align: center;">M102</p>  <p style="text-align: right; font-size: small;">CR07F002</p>	<p style="text-align: center;">M103</p>  <p style="text-align: right; font-size: small;">CR02F046</p>	<p style="text-align: center;">BLANK</p>	<p style="text-align: center;">BLANK</p>
<p style="text-align: center;">MA04</p>  <p style="text-align: right; font-size: small;">CR10B006</p>		<p style="text-align: center;">MD01</p>  <p style="text-align: right; font-size: small;">CR06B006</p>	

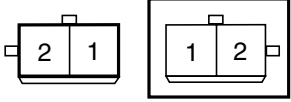
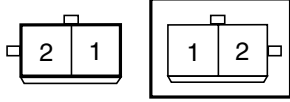
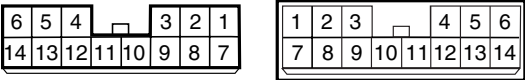
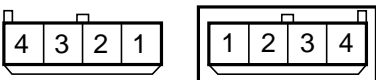
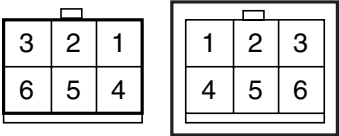
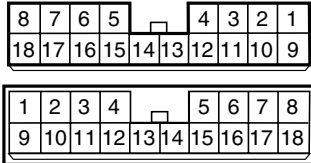
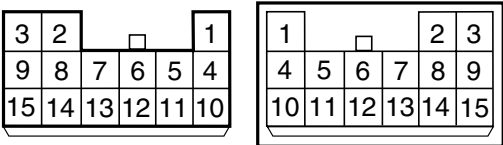
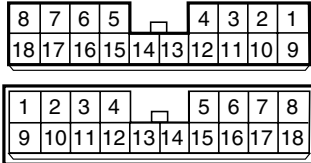
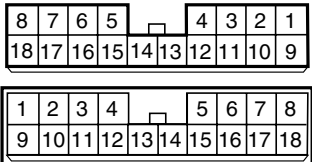
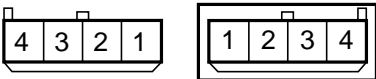
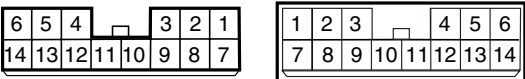
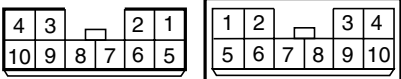

MAIN HARNESS (5)

<p style="text-align: center;">MD02</p>  <p style="text-align: right; font-size: small;">CR02B012</p>	<p style="text-align: center;">MD03</p>  <p style="text-align: right; font-size: small;">CR02B012</p>
<p style="text-align: center;">MI01</p>  <p style="text-align: right; font-size: small;">CR14B011</p>	<p style="text-align: center;">MM01</p>  <p style="text-align: right; font-size: small;">CR04B013</p>
<p style="text-align: center;">MM02</p>  <p style="text-align: right; font-size: small;">CR06B009</p>	<p style="text-align: center;">MM03</p>  <p style="text-align: right; font-size: small;">CR18B005</p>
<p style="text-align: center;">MM04</p>  <p style="text-align: right; font-size: small;">CR15B002</p>	<p style="text-align: center;">MM05</p>  <p style="text-align: right; font-size: small;">CR18B005</p>
<p style="text-align: center;">MM06</p>  <p style="text-align: right; font-size: small;">CR18B005</p>	<p style="text-align: center;">MM07</p>  <p style="text-align: right; font-size: small;">CR04B013</p>
<p style="text-align: center;">MR02</p>  <p style="text-align: right; font-size: small;">CR14B011</p>	<p style="text-align: center;">MR03</p>  <p style="text-align: right; font-size: small;">CR10B006</p>





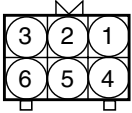
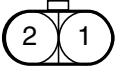
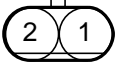
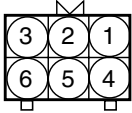
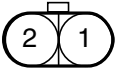
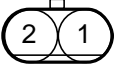
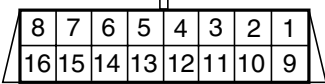
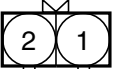

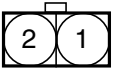
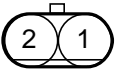
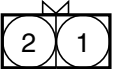
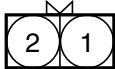
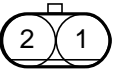
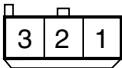
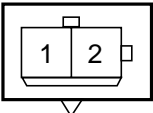
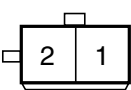
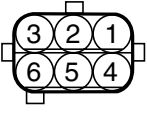
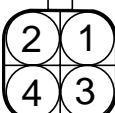
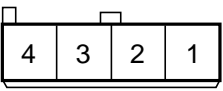
UNDER FLOOR HARNESS

EB8DB232

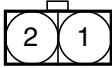
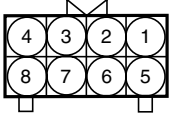
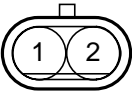
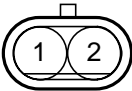
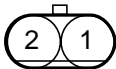
UNDER FLOOR HARNESS (1)

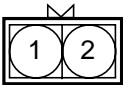
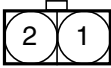
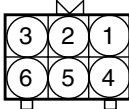
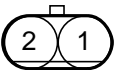
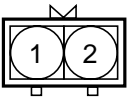
<p>M50</p>  <p>CR06F016</p>	<p>M51</p>  <p>CR02F001</p>	<p>M52</p>  <p>CR02F075</p>	<p>M53</p>  <p>CR06F016</p>
<p>M54</p>  <p>CR02F001</p>	<p>M55</p>  <p>CR02F075</p>	<p>M57</p>  <p>CR16F035</p>	
<p>BLANK</p>	<p>M58</p>  <p>CR02F040</p>	<p>M59</p>  <p>CR01F020</p>	<p>M60</p>  <p>CR02F002</p>
<p>M61</p>  <p>CR02F075</p>	<p>M62</p>  <p>CR02F040</p>	<p>M66</p>  <p>CR02F040</p>	<p>M67</p>  <p>CR02F075</p>
<p>BLANK</p>	<p>M69-1</p>  <p>CR03F026</p>	<p>M69-2</p>  <p>CR02M020</p>	<p>M69-3</p>  <p>CR02F046</p>
<p>BLANK</p>	<p>M72</p>  <p>CR06F046</p>	<p>M73</p>  <p>CR04F014</p>	<p>M74</p>  <p>CR04F048</p>

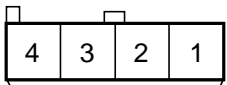
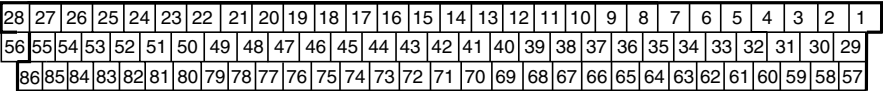
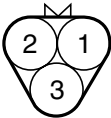
UNDER FLOOR HARNESS (2)

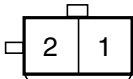
<p>M75</p>  <p>CR01F038</p>	<p>BLANK</p>	<p>M77-1</p>  <p>CR02F002</p>	<p>M77-2</p>  <p>CR08F021</p>
<p>M78</p>  <p>CR02M021</p>	<p>M79</p>  <p>CR02M021</p>	<p>M80</p>  <p>CR02F075</p>	<p>M81</p>  <p>CR01F002</p>
<p>M82-1</p>  <p>CR02M003</p>	<p>M82-2</p>  <p>CR02F002</p>	<p>M82-3</p>  <p>CR06F016</p>	<p>BLANK</p>
<p>M83</p>  <p>CR02F075</p>	<p>M84</p>  <p>CR02M023</p>	<p>M85</p>  <p>CR02F040</p>	<p>M86</p>  <p>CR04F048</p>
<p>M87</p>  <p>CR86F001</p>			
<p>M88</p>  <p>CR03F059</p>	<p>M89</p>  <p>CR01F020</p>	<p>M105</p>  <p>CR01F021</p>	<p>106</p>  <p>CR02F046</p>



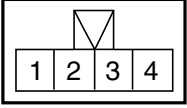
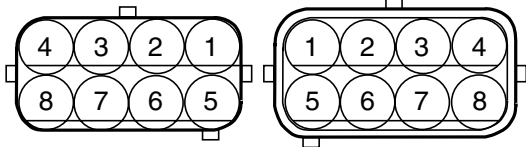
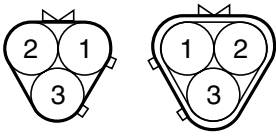
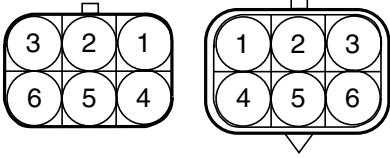
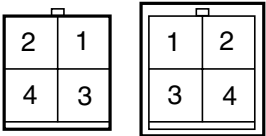
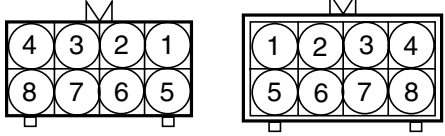
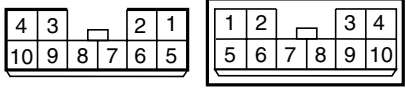
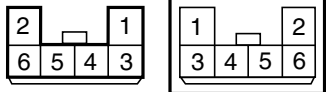
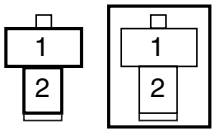
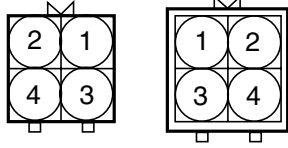
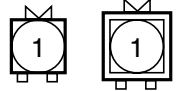
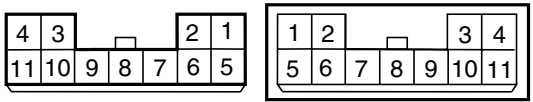
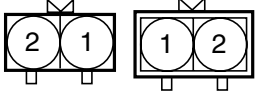







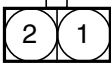
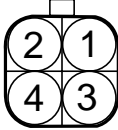
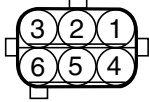

UNDER FLOOR HARNESS (3)

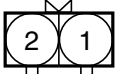
<p>M107</p>  <p>CR04M006</p>	<p>BLANK</p>	<p>EM01</p>  <p>CR08B023</p>	
<p>EM02</p>  <p>CR03B007</p>		<p>EM03</p>  <p>CR06B012</p>	
<p>EM04</p>  <p>CR04B003</p>	<p>EM05</p>  <p>CR08B005</p>		
<p>MA01</p>  <p>CR10B006</p>		<p>MA02</p>  <p>CR06B006</p>	
<p>MA03</p>  <p>CR02B015</p>	<p>MA05</p>  <p>CR04B007</p>	<p>BLANK</p>	<p>MM08</p>  <p>CR01B002</p>
<p>MR01</p>  <p>CR11B004</p>		<p>MR04</p>  <p>CR02B011</p>	

ENGINE HARNESS

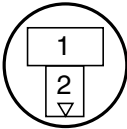

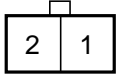

E389AA8D

ENGINE HARNESS (1)

<p>E01</p>  <p>CR01F002</p>	<p>E02</p>  <p>CR02F002</p>	<p>E03-1</p>  <p>CR04F014</p>	<p>E03-2</p>  <p>CR06F046</p>
<p>BLANK</p>	<p>E04</p>  <p>CR01F020</p>	<p>E05</p>  <p>CR02F021</p>	<p>E06</p>  <p>CR02F021</p>
<p>E08</p>  <p>CR02F040</p>	<p>E09</p>  <p>CR01F035</p>	<p>E10</p>  <p>CR01F001</p>	<p>E11</p>  <p>CR01F038</p>
<p>BLANK</p>	<p>E13</p>  <p>CR02F126</p>	<p>E14</p>  <p>CR01F040</p>	<p>BLANK</p>
<p>E15</p>  <p>CR01F026</p>	<p>E16</p>  <p>CR02F076</p>	<p>E17</p>  <p>CR01F034</p>	<p>BLANK</p>

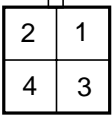
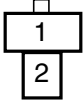
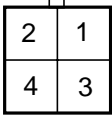
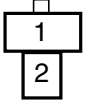
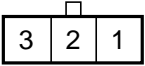
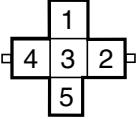
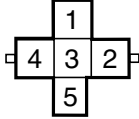
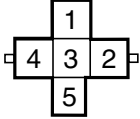
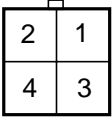
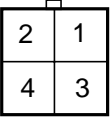
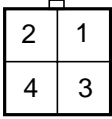
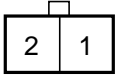
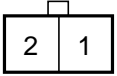
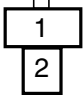
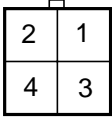
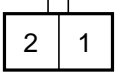
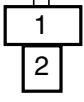
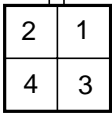
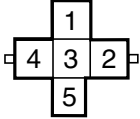
A/C HARNESS E3E14EA4



A/C HARNESS (1)

<p>A01</p>  <p>CR04F001</p>	<p>A02</p>  <p>CR02F012</p>	<p>A03</p>  <p>CR04F001</p>	<p>A04</p>  <p>CR02F012</p>
<p>A05</p>  <p>CR03F040</p>	<p>A06</p>  <p>CR05F001</p>	<p>A07</p>  <p>CR05F001</p>	<p>A08</p>  <p>CR05F001</p>
<p>A09</p>  <p>CR04F001</p>	<p>A10</p>  <p>CR04F001</p>	<p>A11</p>  <p>CR04F001</p>	<p>A12</p>  <p>CR02F076</p>
<p>A13</p>  <p>CR02F076</p>	<p>A14</p>  <p>CR02F012</p>	<p>A15</p>  <p>CR04F001</p>	<p>BLANK</p>
<p>A17</p>  <p>CR02F076</p>	<p>A18</p>  <p>CR02F012</p>	<p>A19</p>  <p>CR04F001</p>	<p>A20</p>  <p>CR05F001</p>
<p>A23</p>  <p>CR02F115</p>	<p>A24</p>  <p>CR02M51</p>	<p>A25</p>  <p>CR02M51</p>	<p>BLANK</p>

REAR BODY, LICENSE & REAR FOG LAMP HARNESS

ECB4DEDE

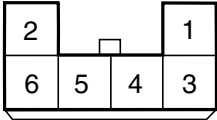
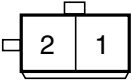
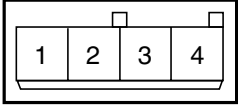
REAR BODY, LICENSE & REAR FOG LAMP HARNESS (1)

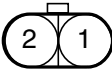
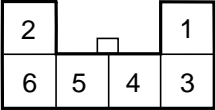
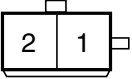
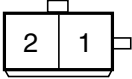
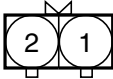
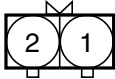
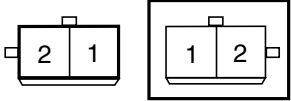

<p>R01</p>  <p>CR06F017</p>	<p>R02</p>  <p>CR02F046</p>	<p>BLANK</p>	<p>R04</p>  <p>CR04M021</p>
<p>BLANK</p>	<p>R05</p>  <p>CR01F043</p>	<p>R06</p>  <p>CR02F001</p>	<p>R07</p>  <p>CR06F003</p>
<p>R08</p>  <p>CR02F050</p>	<p>R09</p>  <p>CR02F050</p>	<p>R50</p>  <p>CR02F040</p>	<p>R51</p>  <p>CR02F040</p>
<p>RR03</p>  <p>CR02B012</p>		<p>BLANK</p>	<p>BLANK</p>

ROOM, READING & SPEAKER HARNESS EE3DCCA4

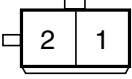
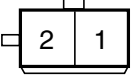
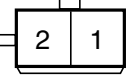
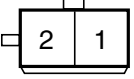
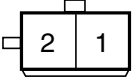
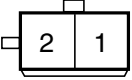
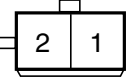
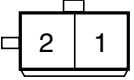
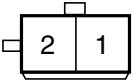
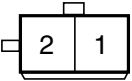
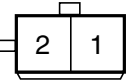
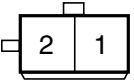
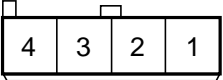
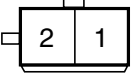
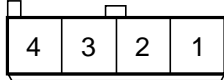
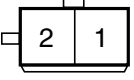
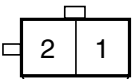
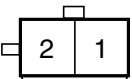
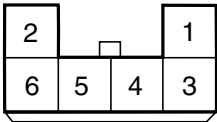
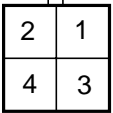
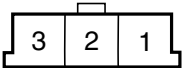
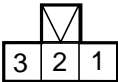
ROOM, READING & SPEAKER HARNESS (1)



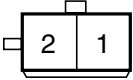
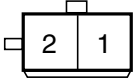
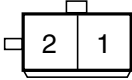
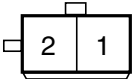
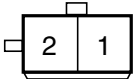
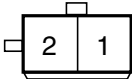
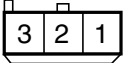
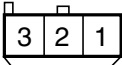
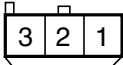
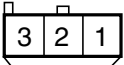

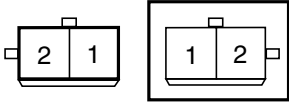
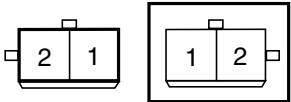
<p>R11</p>  <p>CR02F046</p>	<p>R11-1</p>  <p>CR02F046</p>	<p>R12</p>  <p>CR02F046</p>	<p>R12-1</p>  <p>CR02F046</p>
<p>R13</p>  <p>CR02F046</p>	<p>R13-1</p>  <p>CR02F046</p>	<p>R14</p>  <p>CR02F046</p>	<p>R14-1</p>  <p>CR02F046</p>
<p>R15</p>  <p>CR02F046</p>	<p>R15-1</p>  <p>CR02F046</p>	<p>R16</p>  <p>CR02F046</p>	<p>R16-1</p>  <p>CR02F046</p>
<p>R21</p>  <p>CR04F048</p>	<p>R21-1</p>  <p>CR02F046</p>	<p>R22</p>  <p>CR04F048</p>	<p>R22-1</p>  <p>CR02F046</p>
<p>R23</p>  <p>CR02F046</p>	<p>R23-1</p>  <p>CR02F046</p>	<p>R24</p>  <p>CR06F017</p>	<p>R26</p>  <p>CR04F001</p>
<p>R27</p>  <p>CR03F011</p>	<p>R28</p>  <p>CR03F007</p>	<p>BLANK</p>	<p>BLANK</p>

ROOM, READING & SPEAKER HARNESS (2)

<p>R31</p>  <p>CR02F046</p>	<p>R32</p>  <p>CR02F046</p>	<p>R33</p>  <p>CR02F046</p>	<p>BLANK</p>
<p>R34</p>  <p>CR02F046</p>	<p>R35</p>  <p>CR02F046</p>	<p>R36</p>  <p>CR02F046</p>	<p>R38</p>  <p>CR03F026</p>
<p>BLANK</p>	<p>R39</p>  <p>CR03F026</p>	<p>R40</p>  <p>CR03F026</p>	<p>R41</p>  <p>CR03F026</p>
<p>R42</p>  <p>CR01F021</p>	<p>R43</p>  <p>CR01F021</p>	<p>RR01</p>  <p>CR02B012</p>	
<p>RR02</p>  <p>CR02B012</p>		<p>BLANK</p>	<p>BLANK</p>

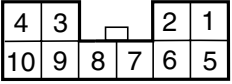
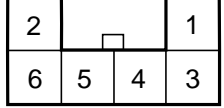
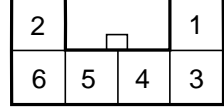
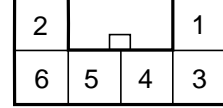
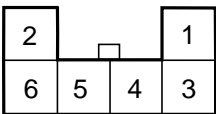
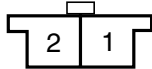
FACIA & DOOR HARNESS E5FBCFB2

FACIA & DOOR HARNESS (1)

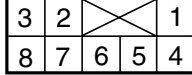
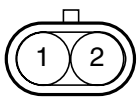
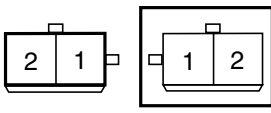
<p style="text-align: center;">I01</p>  <p style="text-align: right; font-size: small;">CR10F004</p>	<p style="text-align: center;">I02</p>  <p style="text-align: right; font-size: small;">CR06F003</p>	<p style="text-align: center;">I03</p>  <p style="text-align: right; font-size: small;">CR06F003</p>	<p style="text-align: center;">I04</p>  <p style="text-align: right; font-size: small;">CR06F003</p>
<p style="text-align: center;">I05</p>  <p style="text-align: right; font-size: small;">CR06F003</p>	<p style="text-align: center;">BLANK</p>	<p style="text-align: center;">I06</p>  <p style="text-align: right; font-size: small;">CR02F010</p>	<p style="text-align: center;">I07</p>  <p style="text-align: right; font-size: small;">CR01F022</p>
<p style="text-align: center;">I08</p>  <p style="text-align: right; font-size: small;">CR01F027</p>	<p style="text-align: center;">I09</p>  <p style="text-align: right; font-size: small;">CR01F027</p>	<p style="text-align: center;">D01</p>  <p style="text-align: right; font-size: small;">CR08F027</p>	<p style="text-align: center;">D02</p>  <p style="text-align: right; font-size: small;">CR02M001</p>
<p style="text-align: center;">DD01</p>  <p style="text-align: right; font-size: small;">CR02B009</p>		<p style="text-align: center;">BLANK</p>	<p style="text-align: center;">> BLANK</p>

Harness Layouts

MAIN HARNESS	HL- 2
UNDER FLOOR HARNESS	HL- 4
ENGINE HARNESS	HL- 6
OVERHEAD A/C HARNESS	HL- 7
FLOOR & DOOR HARNESS	HL- 8
REAR BODY & LICENSE LAMP HARNESS	HL- 9
ROOM, READING AND SPEAKER HARNESS	HL-10

MAIN HARNESS E0E23ABA

MAIN HARNESS (1)

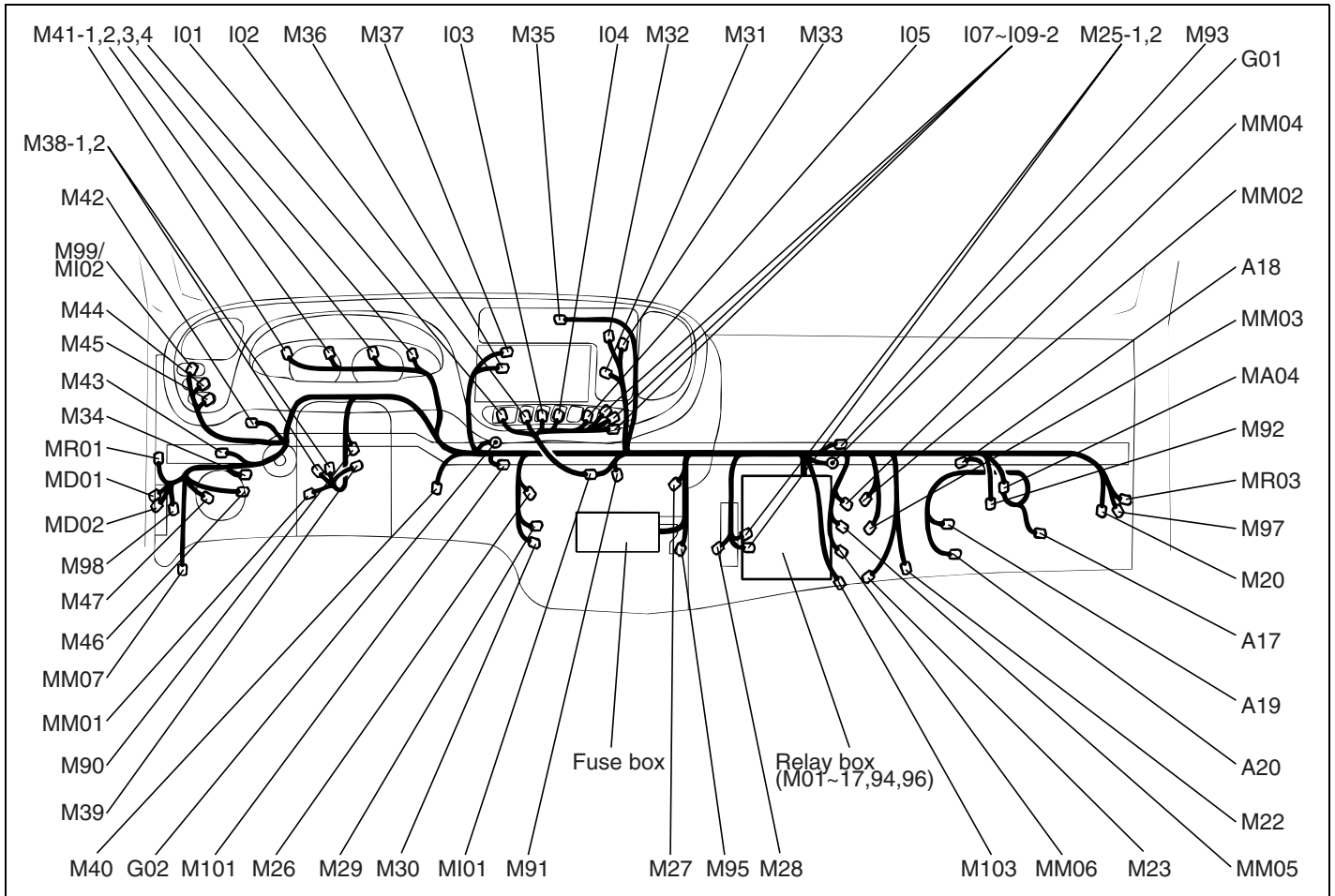

E5QD001A

CHASSIS SWITCH HARNESS

- M48 Accelerator switch
- M49 Stop lamp switch
- MM01 Connection with MAIN harness

BLOWER HARNESS

- A17 Intake actuator
- A18 Blower motor
- A19 Blower resistor
- A20 Blower relay
- MA04 Connection with MAIN harness

FACIA HARNESS

- I01 Hazard switch
- I02 Room lamp switch #1
- I03 Room lamp switch #2
- I04 Fog lamp switch
- I05 Reading lamp switch
- I07 Cigarette lighter
- I08 Cigarette lighter
- I09-1 Cigarette lighter (ILL+)
- I09-2 Cigarette lighter (ILL-)
- MI01 Connection with MAIN harness

MAIN HARNESS (2)

MAIN HARNESS

M01	Fog lamp relay	M41-3	Instrument cluster
M02	Tail lamp relay	M41-4	Instrument cluster
M03	Hazard relay	M42	Ventilator switch
M05	Accelerator inter relay	M43	Brake fluid level sensor
M06	Reading lamp relay	M44	Rear wiper & washer switch
M07	Rear wiper relay	M45	Cold start switch
M08	Flasher unit	M46	Clutch switch
M09	Wiper relay(High)	M47	Tachograph
M10	Wiper relay(Low)	M90	Joint connector
M11	Head lamp relay (High)	M91	Joint connector
M12	Head lamp relay (Low)	M92	High speed warning device (MES)
M13	DBR relay	M93	Joint connector
M14	Evaporator relay 1	M94	Overheat warning relay
M15	Evaporator relay 2	M95	Overheat warning buzzer
M16	Evaporator relay 3	M96	Mirror defogger relay
M17	Rear heater relay	M97	Right mirror defogger
M20	Front washer motor	M99	Mirror defogger switch
M25-1	ETACM	M101	Ashtray
M25-2	ETACM	M102	Rear fog lamp switch
M26	Joint connector	M103	High speed warning buzzer (MES)
M27	Joint connector	MA04	Connection with BLOWER harness
M28	Accelerator interlock motor	MD01	Connection with DOOR harness
M29	Mode actuator	MD02	Connection with DOOR harness
M30	Front wiper motor	MD03	Connection with DOOR harness
M31	Blower switch	MI01	Connection with FACIA harness
M32	Preheater switch	MM01	Connection with CHASSIS SWITCH harness
M33	A/C control panel	MM02	Connection with UNDER FLOOR harness
M34	Joint connector	MM03	Connection with UNDER FLOOR harness
M35	Heater control panel	MM04	Connection with UNDER FLOOR harness
M36	Route guide controller	MM05	Connection with UNDER FLOOR harness
M37	Audio	MM06	Connection with UNDER FLOOR harness
M38-1	Multifunction switch	MM07	Connection with FLOOR harness
M38-2	Multifunction switch	MR02	Connection with ROOM LAMP harness
M39	Ignition switch	MR03	Connection with SPEAKER harness
M40	Door open switch	G01	Ground
M41-1	Instrument cluster	G02	Ground
M41-2	Instrument cluster	Z04	Diode
		Z05	Diode
		Z06	Diode
		Z09	Diode

UNDER FLOOR HARNESS

E6CAABFF

UNDER FLOOR HARNESS (1)

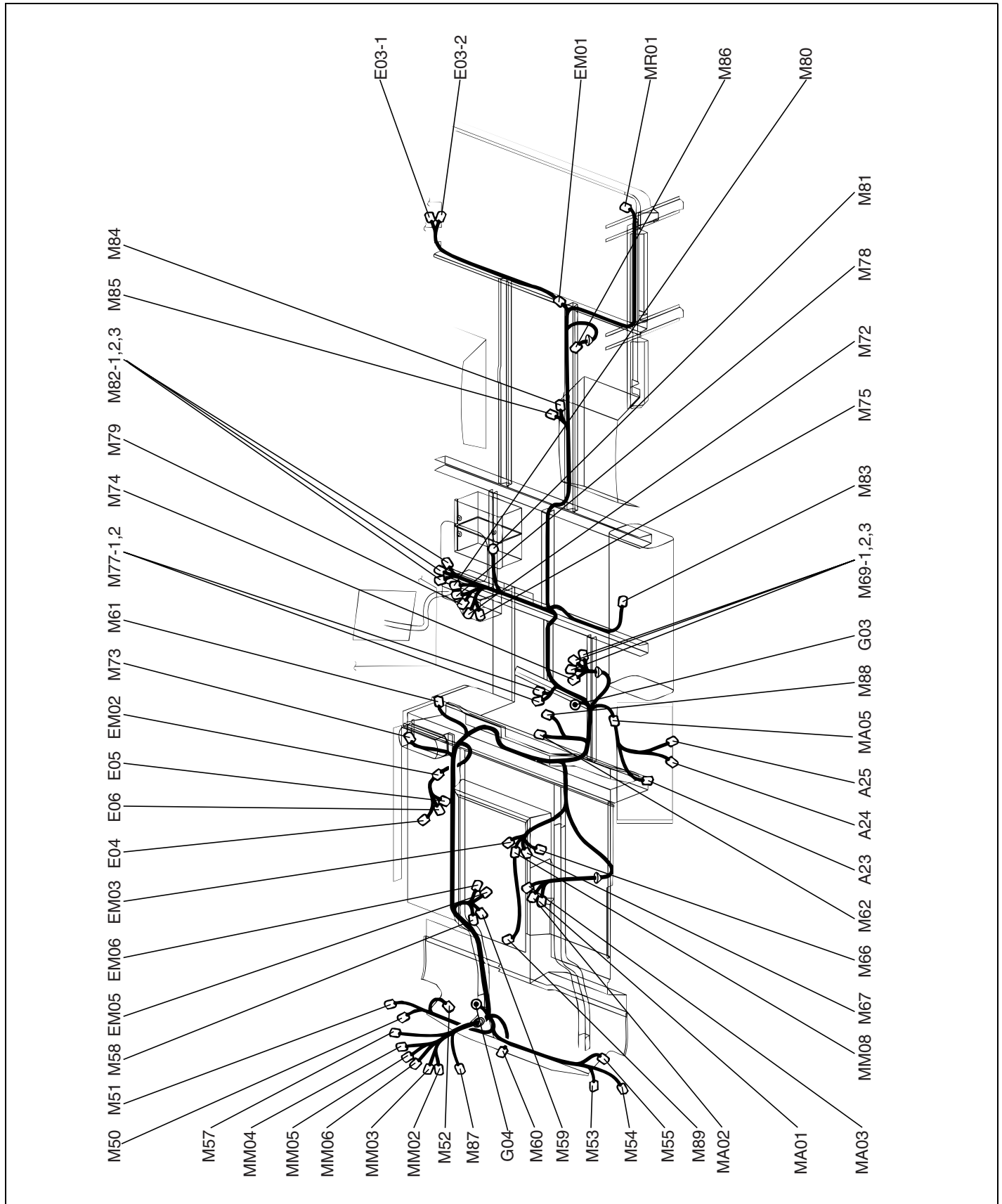

UNDER FLOOR HARNESS (2)

- M50 Left head lamp
- M51 Left turn signal lamp
- M52 Left fog lamp
- M53 Right head lamp
- M54 Right turn signal lamp
- M55 Right fog lamp
- M57 ABS check connector
- M58 Right front wheel sensor
- M59 A/C compressor
- M60 Horn
- M61 Step lamp (Swing door)
- M62 Back-up lamp switch
- M66 Left front wheel sensor
- M67 A/C idle solenoid
- M69-1 Photo relay
- M69-2 Photo relay (Emit)
- M69-3 Photo relay (Receive)
- M72 Swing door controller
- M73 Folding door controller
- M74 Heater #1
- M75 Swing door (Latch)
- M77-1 Hydraulic unit
- M77-2 Hydraulic unit
- M78 Photocell (Receive)
- M79 Photocell (Emit)
- M80 Step lamp (Folding door)
- M81 Battery terminal

TWIN COMPRESSOR HARNESS

- M89 Twin compressor
- MM08 Connection with UNDER FLOOR harness

CONDENSER HARNESS

- A23 Dual pressure switch
- A24 Condenser motor #1
- A25 Condenser motor #2
- MA05 Connection with UNDER FLOOR harness

- M82-1 ABS relay box 1
- M82-2 ABS relay box 2
- M82-3 ABS relay box 3
- M83 Fuel sender
- M84 Right rear wheel sensor
- M85 Left rear wheel sensor
- M86 Heater #2
- M87 ABS control module
- M88 Vehicle speed sensor
- EM01 Connection with PREHEATER harness
- EM02 Connection with CHASSIS VALVE harness
- EM03 Connection with ENGINE(LEFT) harness
- EM05 Connection with ENGINE(RIGHT) harness
- EM06 Connection with ENGINE(RIGHT) harness
- EA01 Connection with OVERHEAD A/C harness
- MA02 Connection with OVERHEAD A/C harness
- MA03 Connection with OVERHEAD A/C harness
- MA05 Connection with CONDENSER harness
- MM02 Connection with MAIN harness
- MM03 Connection with MAIN harness
- MM04 Connection with MAIN harness
- MM05 Connection with MAIN harness
- MM06 Connection with MAIN harness
- MM08 Connection with TWIN COMPRESSOR harness
- MR01 Connection with REAR BODY harness
- MR04 Connection with REAR FOG LAMP harness
- G03 Ground
- G04 Ground
- Z01 Diode
- Z02 Diode

PREHEATER HARNESS

- E03-1 Preheater unit
- E03-2 Preheater unit
- EM01 Connection with UNDER FLOOR harness

CHASSIS VALVE HARNESS

- E04 Vacuum switch
- E05 Silencer magnetic valve
- E06 Exhaust magnetic valve
- EM02 Connection with UNDER FLOOR harness
- Z03 Diode

ENGINE HARNESS

EC6F9DF5

ENGINE HARNESS (1)

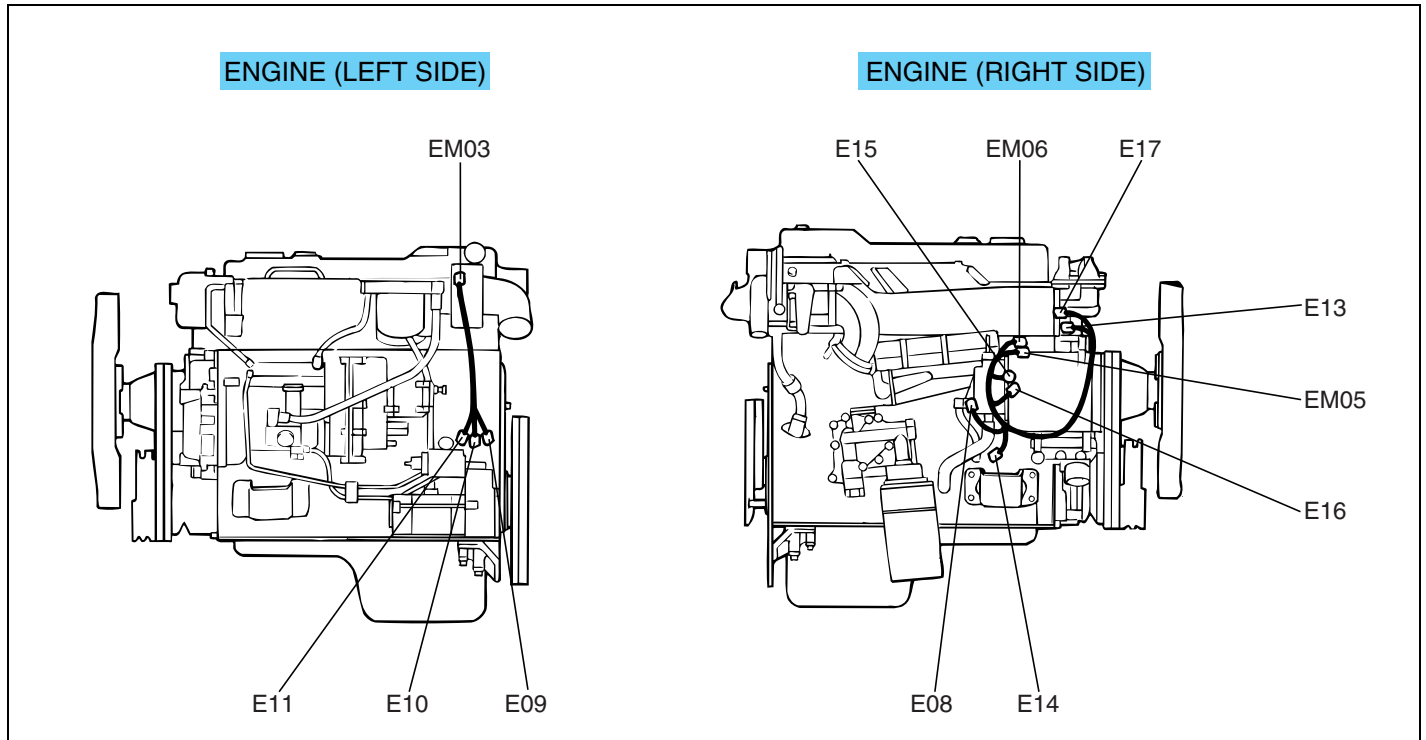

E5QD004A

ENGINE(LEFT) HARNESS

ENGINE(RIGHT) HARNESS

- E09 Starter motor solenoid
- E10 Air heater relay
- E11 Air heater relay fuse
- EM03 Connection with UNDER FLOOR harness

- E08 Tachometer sensor
- E13 Engine coolant temperature sensor
- E14 Oil pressure switch
- E15 Generator (B+)
- E16 Generator (L, S)
- E17 Overheat warning switch
- EM05 Connection with UNDER FLOOR harness
- EM06 Connection with UNDER FLOOR harness

OVERHEAD A/C HARNESS E7F9BDE8

OVERHEAD A/C HARNESS (1)

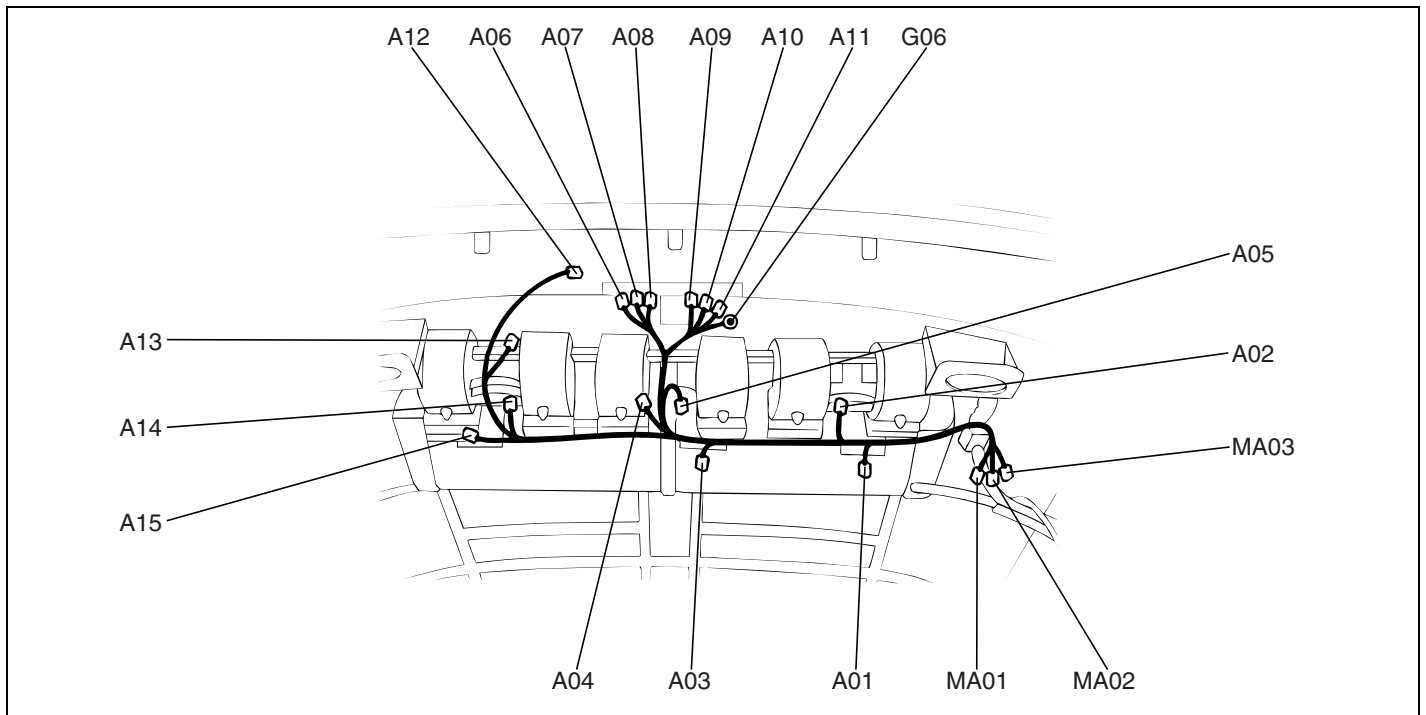

E5QD005A

A01	Resistor #1	A10	Compressor relay
A02	Blower motor #1	A11	Middle high relay #2
A03	Resistor #2	A12	Fresh actuator
A04	Blower motor #2	A13	Return actuator
A05	Thermostatic switch	A14	Blower motor #3
A06	Middle high relay #1	A15	Resistor #3
A07	High relay #1	MA01	Connection with UNDER FLOOR harness
A08	Condenser relay	MA02	Connection with UNDER FLOOR harness
A09	High relay #2	MA03	Connection with UNDER FLOOR harness
		G06	Ground

FLOOR & DOOR HARNESS

E094BC05

FLOOR & DOOR HARNESS (1)

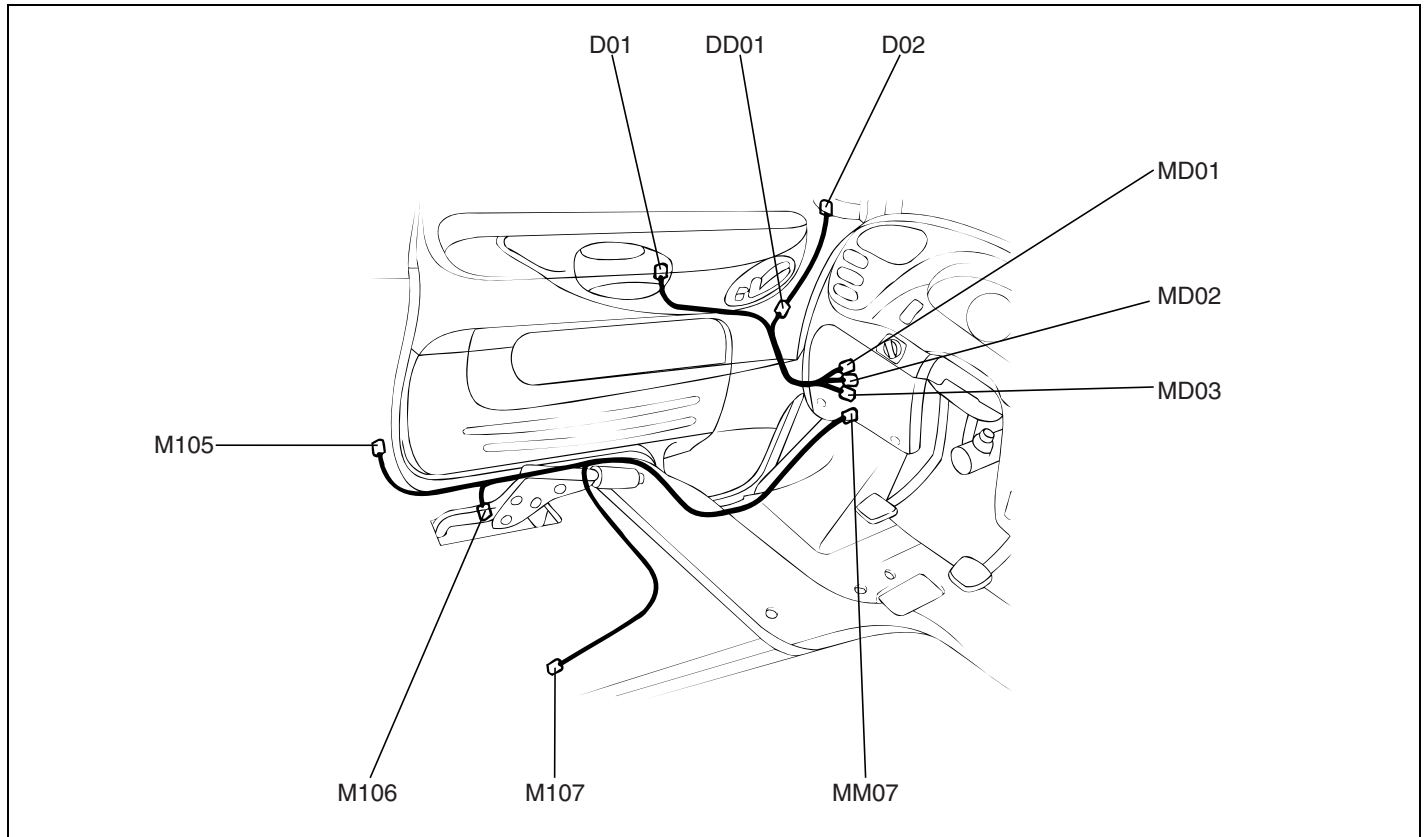

E5QD003A

FLOOR HARNESS

DOOR HARNESS

- M105 Front door switch
- M106 Parking brake switch
- M107 Seat belt switch
- MM07 Connection with MAIN harness

- D01 Route guide
- D02 Left mirror defogger
- MD01 Connection with MAIN harness
- MD02 Connection with MAIN harness
- MD03 Connection with MAIN harness
- DD01 Connection with DEFOGGER EXT. harness

REAR BODY & LICENSE LAMP HARNESS E15586FC

REAR BODY & LICENSE LAMP HARNESS (1)

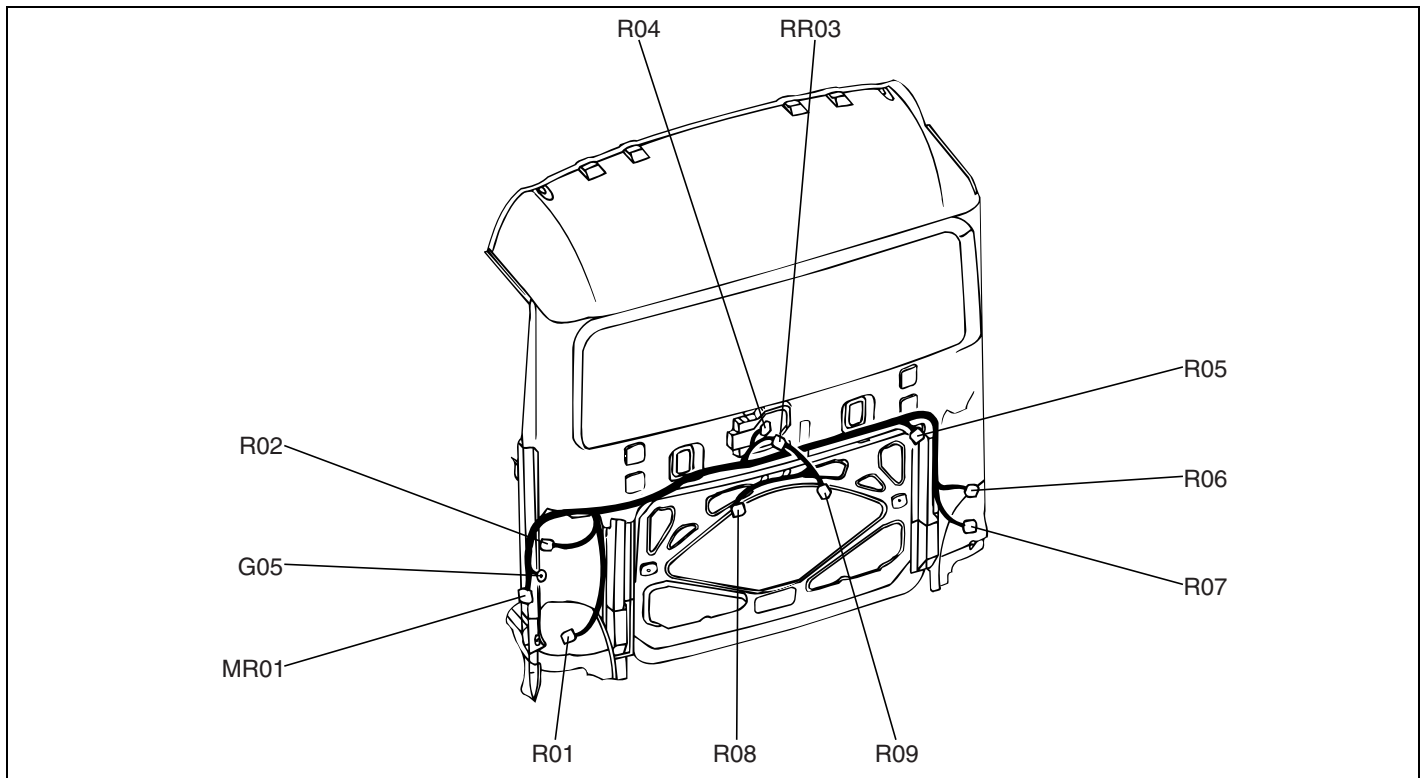

E5QD006A

REAR BODY HARNESS

- R01 Left rear combination lamp
- R02 Luggage lamp
- R04 Rear wiper motor
- R05 Flap door switch
- R06 Rear washer motor
- R07 Right rear combination lamp
- MR01 Connection with UNDER FLOOR harness
- RR03 Connection with LICENSE LAMP harness
- G05 Ground

LICENSE LAMP HARNESS

- R08 Right license lamp
- R09 Left license lamp
- RR03 Connection with REAR BODY harness

REAR FOG LAMP HARNESS

- R50 Right rear fog lamp
- R51 Left rear fog lamp
- MR04 Connection with UNDER FLOOR harness

ROOM, READING AND SPEAKER HARNESS

E374FA0E

ROOM, READING AND SPEAKER HARNESS (1)

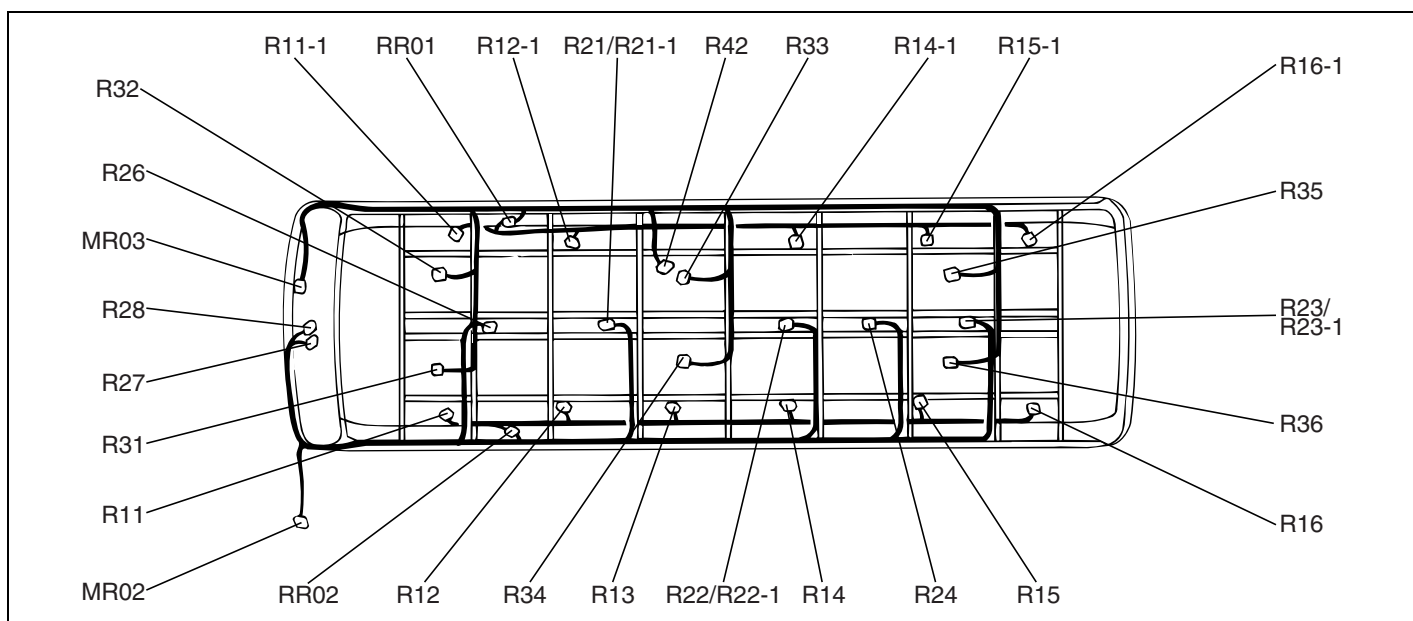

E5QD007A

READING LAMP HARNESS

- R11 Left reading lamp #1
- R11-1 Right reading lamp #1
- R12 Left reading lamp #2
- R12-1 Right reading lamp #2
- R13 Left reading lamp #3
- R13-1 Right reading lamp #3
- R14 Left reading lamp #4
- R14-1 Right reading lamp #4
- R15 Left reading lamp #5
- R15-1 Right reading lamp #5
- R16 Left reading lamp #6
- R16-1 Right reading lamp #6
- RR01 Connection with SPEAKER harness
- RR02 Connection with ROOM LAMP harness

- R26 Roof clock
- R27 Driver room lamp
- R28 Driver room lamp
- MR02 Connection with MAIN harness
- RR02 Connection with READING LAMP harness

SPEAKER HARNESS

- R31 Left speaker#1
- R32 Right speaker #1
- R33 Right speaker #2
- R34 Left speaker #2
- R35 Right speaker #3
- R36 Left speaker #3
- R42 Swing door switch
- R43 Folding door switch
- MR03 Connection with MAIN harness
- RR01 Connection with READING LAMP harness

ROOM LAMP HARNESS

- R21 Room lamp #1 (Fluorescent)
- R21-1 Room lamp #1 (Incandescent)
- R22 Room lamp #2 (Fluorescent)
- R22-1 Room lamp #2 (Incandescent)
- R23 Room lamp #3 (Fluorescent)
- R23-1 Room lamp #3 (Incandescent)
- R24 Ventilator motor