

**GENERAL INFORMATION
SECTION**

This service manual has been prepared to provide SUBARU service personnel with the necessary information and data for the correct maintenance and repair of SUBARU vehicles.

This manual includes the procedures for maintenance, disassembling, reassembling, inspection and adjustment of components and diagnostics for guidance of experienced mechanics.

Please peruse and utilize this manual fully to ensure complete repair work for satisfying our customers by keeping their vehicle in optimum condition. When replacement of parts during repair work is needed, be sure to use SUBARU genuine parts.

All information, illustration and specifications contained in this manual are based on the latest product information available at the time of publication approval.

FUJI HEAVY INDUSTRIES LTD.

FOREWORD**FW****HOW TO USE THIS MANUAL****HU****SPECIFICATIONS****SPC****PRECAUTION****PC****NOTE****NT****IDENTIFICATION****ID****RECOMMENDED MATERIALS****RM****PRE-DELIVERY INSPECTION****PI****PERIODICAL MAINTENANCE****PM**

ENGINE1 SECTION

This service manual has been prepared to provide SUBARU service personnel with the necessary information and data for the correct maintenance and repair of SUBARU vehicles.

This manual includes the procedures for maintenance, disassembling, reassembling, inspection and adjustment of components and diagnostics for guidance of experienced mechanics.

Please peruse and utilize this manual fully to ensure complete repair work for satisfying our customers by keeping their vehicle in optimum condition. When replacement of parts during repair work is needed, be sure to use SUBARU genuine parts.

FUEL INJECTION (FUEL SYSTEMS) FU(SOHC)

EMISSION CONTROL (AUX. EMISSION CONTROL DEVICES) EC(SOHC)

INTAKE (INDUCTION) IN(SOHC)

MECHANICAL ME(SOHC)

EXHAUST EX(SOHC)

COOLING CO

LUBRICATION LU

SPEED CONTROL SYSTEMS SP

IGNITION IG(SOHC)

STARTING/CHARGING SYSTEMS SC

ENGINE (DIAGNOSTICS) EN(SOHC)

All information, illustration and specifications contained in this manual are based on the latest product information available at the time of publication approval.

ENGINE2 SECTION

This service manual has been prepared to provide SUBARU service personnel with the necessary information and data for the correct maintenance and repair of SUBARU vehicles.

This manual includes the procedures for maintenance, disassembling, reassembling, inspection and adjustment of components and diagnostics for guidance of experienced mechanics.

Please peruse and utilize this manual fully to ensure complete repair work for satisfying our customers by keeping their vehicle in optimum condition. When replacement of parts during repair work is needed, be sure to use SUBARU genuine parts.

All information, illustration and specifications contained in this manual are based on the latest product information available at the time of publication approval.

FUEL INJECTION (FUEL SYSTEMS) FU(SOHCw/oOBD)

EMISSION CONTROL (AUX. EMISSION CONTROL DEVICES) EC(SOHCw/oOBD)

EXHAUST EX(SOHCw/oOBD)

IGNITION IG(SOHCw/oOBD)

ENGINE (DIAGNOSTICS) EN(SOHCw/oOBD)

FUEL INJECTION (FUEL SYSTEMS) FU(DOHC TURBO)

EMISSION CONTROL (AUX. EMISSION CONTROL DEVICES) EC(DOHC TURBO)

INTAKE (INDUCTION) IN(DOHC TURBO)

MECHANICAL ME(DOHC TURBO)

EXHAUST EX(DOHC TURBO)

IGNITION IG(DOHC TURBO)

ENGINE (DIAGNOSTICS) EN(DOHC TURBO)

TRANSMISSION SECTION

This service manual has been prepared to provide SUBARU service personnel with the necessary information and data for the correct maintenance and repair of SUBARU vehicles.

This manual includes the procedures for maintenance, disassembling, reassembling, inspection and adjustment of components and diagnostics for guidance of experienced mechanics.

Please peruse and utilize this manual fully to ensure complete repair work for satisfying our customers by keeping their vehicle in optimum condition. When replacement of parts during repair work is needed, be sure to use SUBARU genuine parts.

All information, illustration and specifications contained in this manual are based on the latest product information available at the time of publication approval.

CONTROL SYSTEMS	CS
AUTOMATIC TRANSMISSION	AT
MANUAL TRANSMISSION AND DIFFERENTIAL	MT
CLUTCH SYSTEM	CL
AUTOMATIC TRANSMISSION (DIAGNOSTICS)	AT

CHASSIS SECTION

This service manual has been prepared to provide SUBARU service personnel with the necessary information and data for the correct maintenance and repair of SUBARU vehicles.

This manual includes the procedures for maintenance, disassembling, reassembling, inspection and adjustment of components and diagnostics for guidance of experienced mechanics.

Please peruse and utilize this manual fully to ensure complete repair work for satisfying our customers by keeping their vehicle in optimum condition. When replacement of parts during repair work is needed, be sure to use SUBARU genuine parts.

All information, illustration and specifications contained in this manual are based on the latest product information available at the time of publication approval.

FUJI HEAVY INDUSTRIES LTD.

FRONT SUSPENSION FS

REAR SUSPENSION RS

WHEEL AND TIRE SYSTEM WT

DIFFERENTIALS DI

TRANSFER CASE TC

DRIVE SHAFT SYSTEM DS

ABS ABS

BRAKE BR

PARKING BRAKE PB

**POWER ASSISTED SYSTEM
(POWER STEERING)** PS

ABS (DIAGNOSTICS) ABS

BODY SECTION

This service manual has been prepared to provide SUBARU service personnel with the necessary information and data for the correct maintenance and repair of SUBARU vehicles.

This manual includes the procedures for maintenance, disassembling, reassembling, inspection and adjustment of components and diagnostics for guidance of experienced mechanics.

Please peruse and utilize this manual fully to ensure complete repair work for satisfying our customers by keeping their vehicle in optimum condition. When replacement of parts during repair work is needed, be sure to use SUBARU genuine parts.

All information, illustration and specifications contained in this manual are based on the latest product information available at the time of publication approval.

FUJI HEAVY INDUSTRIES LTD.

**HVAC SYSTEM
(HEATER, VENTILATOR AND A/C) AC**

AIRBAG SYSTEM AB

SEAT BELT SYSTEM SB

LIGHTING SYSTEM LI

WIPER AND WASHER SYSTEMS WW

ENTERTAINMENT ET

COMMUNICATION SYSTEM COM

GLASS/WINDOWS/MIRRORS GW

BODY STRUCTURE BS

INSTRUMENTATION/DRIVER INFO IDI

SEATS SE

SECURITY AND LOCKS SL

**SUNROOF/T-TOP/CONVERTIBLE TOP
(SUNROOF) SR**

EXTERIOR/INTERIOR TRIM EI

EXTERIOR BODY PANELS EB

CRUISE CONTROL SYSTEM CC

BODY SECTION

AIRBAG SYSTEM (DIAGNOSTICS) AB

CRUISE CONTROL SYSTEM (DIAGNOSTICS) CC

IMMOBILIZER (DIAGNOSTICS) IM

WIRING SYSTEM SECTION

WIRING SYSTEM

WI

This service manual has been prepared to provide SUBARU service personnel with the necessary information and data for the correct maintenance and repair of SUBARU vehicles.

This manual includes the procedures for maintenance, disassembling, reassembling, inspection and adjustment of components and diagnostics for guidance of experienced mechanics.

Please peruse and utilize this manual fully to ensure complete repair work for satisfying our customers by keeping their vehicle in optimum condition. When replacement of parts during repair work is needed, be sure to use SUBARU genuine parts.

All information, illustration and specifications contained in this manual are based on the latest product information available at the time of publication approval.

FOREWORD

FW 

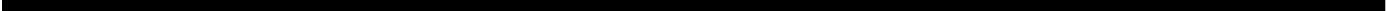

1. Foreword	Page 2
-------------------	-----------

1. Foreword SA01674

A: FOREWORD SA01674G21

These manuals are used when performing maintenance, repair, or diagnosis of the Subaru Forester.

Applied model: SF***** from 2001MY.

The additional manuals below are also available:
AUTOMATIC TRANSMISSION SERVICE
MANUAL (Pub. No. G0853ZE)

The manuals contain the latest information at the time of publication. Changes in specifications, methods, etc. may be made without notice.

HOW TO USE THIS MANUALS

HU



	Page
1. How to Use This Manuals.....	2



1. How to Use This Manuals SA02675

A: HOW TO USE THIS MANUALS

SA02675F69

1. STRUCTURE SA02675F6901

Each section consists of SCT that are broken down into SC that are divided into sections for each component. The specification, maintenance and other information for the components are included, and diagnosis information has also been added where necessary.

2. INDEX SA02675F6902

The first page has an index with tabs. And at the end of each section is an alphabetical index.

3. COMPONENTS SA02675F6903

For each component, a composition drawing is included.

4. SPECIFICATIONS SA02675F6904

If necessary, specifications are also included

5. INSPECTION SA02675F6905

Inspections are included to be carried out before and after maintenance.

6. MAINTENANCE SA02675F6906

Maintenance instructions are provided for each component. When multiple components comprise one process, refer to the instructions for that process for each component.

7. DIAGNOSIS SA02675F6907

Tables showing a step-by-step process make it easy to conduct diagnosis.

8. SI UNITS SA02675F6909

Measurements in these manuals are according to the SI units. Metric and yard/pound measurements are also included.

SPECIFICATIONS

SPC

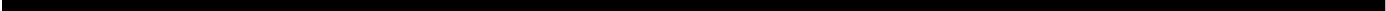

1. Forester	Page 2
-------------------	-----------

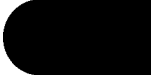

FORESTER

Specifications

1. Forester SA08758

A: DIMENSIONS SA08758G28

Model		2.0 L Non-TURBO	2.0 L TURBO
Overall length	mm (in)	4,460 (175.6), 4,530 (178.3)*1	
Overall width	mm (in)	1,735 (68.3), 1,765 (69.5)*2	
Overall height (at CW)	mm (in)	1,595 (62.8)	1,585 (62.4)
Compartment	Length	1,745 (68.7)	
	Width	1,435 (56.5)	
	Height	1,245 (49.0), 1,220 (48.0)*3	
Wheelbase	mm (in)	2,525 (99.4)	
Tread	Front	1,475 (58.1)	
	Rear	1,465 (57.7)	
Minimum road clearance	mm (in)	190 (7.5), 200 (7.9)*4	

*1: With bushing bar

*2: With fender flare

*3: With sunroof

*4: Australia spec. vehicles

B: ENGINE SA08758G29

Model		2.0 L Non-TURBO	2.0 L TURBO
Engine type		Horizontally opposed, liquid cooled, 4-cylinder, 4-stroke gasoline engine	
Valve arrangement		Overhead camshaft type	
Bore × Stroke	mm (in)	92 × 75 (3.62 × 2.95)	
Displacement	cm ³ (cu in)	1,994 (121.67)	
Compression ratio		10.0	8.0
Firing order		1 — 3 — 2 — 4	
Idle speed at Park/ Neutral position	rpm	700±100	
Maximum output	kW (HP)/rpm	101 (137)/5,600	130 (174)/5,600
Maximum torque	N·m (kgf-m, ft-lb)/rpm	186 (19.0, 137.0)/3,600	245 (25, 181)/3,200

C: ELECTRICAL SA08758G30

Model		2.0 L Non-TURBO	2.0 L TURBO
Ignition timing at idling speed	BTDC/rpm	12°±10°/700	
Spark plug	Type and manufacturer	NGK: BK5E-11 (without catalyst) CHAMPION: RC10YC4 (with catalyst)	NGK: PFR6B
Generator		12 V — 75 A	
Battery	Type and capacity (5HR)	For Europe	5MT: 12 V — 48AH 4AT: 12 V — 52AH
		For Australia	12 V — 40AH
		Others	12 V — 40AH

D: TRANSMISSION SA08758G31

Model		2.0 L Non-TURBO		2.0 L TURBO		
		AWD				
Transmission type		5MT*1	4AT*2	5MT*1	4AT*2	
Clutch type		DSPD	TCC	DSPD	TCC	
Gear ratio	1st	3.454	2.785	3.454	2.785	
	2nd	2.062	1.545	1.947	1.545	
	3rd	1.448	1.000	1.366	1.000	
	4th	1.088	0.694	0.972	0.694	
	5th	0.871	—	0.738	—	
	Reverse	3.333	2.272	3.333	2.272	
Auxiliary transmission gear ratio	High	1.000	—	—	—	
	Low	1.447	—	—	—	
Reduction gear (Front drive)	1st reduction	Type of gear	—	Helical	—	Helical
		Gear ratio	—	1.000	—	1.000
	Final reduction	Type of gear	Hypoid	Hypoid	Hypoid	Hypoid
		Gear ratio	4.111	4.444	4.444	4.111
Reduction gear (Rear drive)	Transfer reduction	Type of gear	Hypoid	—	Hypoid	—
		Gear ratio	1.000	—	1.081*4, 1.000*5	—
	Final reduction	Type of gear	Hypoid	Hypoid	Hypoid	Hypoid
		Gear ratio	4.111	4.444	4.111*4, 4.444*5	4.111

5MT*1: 5 × 2 forward speeds with synchromesh and 1-reverse — with center differential and viscous coupling

4AT*2: Electronically controlled fully-automatic, 4-forward speeds and 1-reverse — with hydraulically controlled transfer clutch

5MT*3: 5-forward speeds with synchromesh and 1-reverse — with center differential and viscous coupling

DSPD: Dry Single Plate Diaphragm

TCC: Torque Converter Clutch

*4: For Europe

*5: Others

E: STEERING SA08758G32

Model		LHD	RHD
Type		Rack and Pinion	
Turns, lock to lock		3.4	3.0
Minimum turning circle m (ft)		Curb to curb: 10.8 (35.4)	

F: SUSPENSION SA08758G33

Front	MacPherson strut type, Independent, Coil spring
Rear	Dual link strut type, Independent, Coil spring

FORESTER

Specifications

G: BRAKE SA08758G34

Model	Australia spec. vehicles and 2000 TURBO	Others
Service brake system	Dual circuit hydraulic with vacuum suspended power unit	
Front	Ventilated disc brake	
Rear	Disc brake	Drum brake
Parking brake	Mechanical on rear brakes	

H: TIRE SA08758G35

Rim size	15 × 6J	16 × 6 ¹ / ₂ JJ
Tire size	205/70R15	215/60R16
Type	Steel belted radial, Tubeless	

I: CAPACITY SA08758G36

Model		2.0 L Non-TURBO		2.0 L TURBO	
		AWD		AWD	
		5MT	4AT	5MT	4AT
Fuel tank	ℓ (US gal, Imp gal)	60 (15.9, 13.2)		60 (15.9, 13.2)	
Engine oil	Upper level	4.5 (4.8, 4.0)		5.0 (5.3, 4.4)	
	Lower level	3.5 (3.7, 3.1)		4.0 (4.2, 3.5)	
Transmission gear oil	ℓ (US qt, Imp qt)	4.0 (4.2, 3.5)	—	3.5 (3.7, 3.1)	—
Automatic transmission fluid	ℓ (US qt, Imp qt)	—	8.4 (8.9, 7.4)	—	9.3 (9.8, 8.2)
AT differential gear oil	ℓ (US qt, Imp qt)	—	1.2 (1.3, 1.1)	—	1.2 (1.3, 1.1)
AWD rear differential gear oil	ℓ (US qt, Imp qt)	0.8 (0.8, 0.6)		0.8 (0.8, 0.6)	
Power steering fluid	ℓ (US qt, Imp qt)	0.7 (0.7, 0.6)		0.7 (0.7, 0.6)	
Engine coolant	ℓ (US qt, Imp qt)	6.4 (6.8, 5.6)	6.3 (6.7, 5.5)	6.4 (6.8, 5.6)	6.3 (6.7, 5.5)

J: WEIGHT SA08758G37

1. EXCEPT AUSTRALIA SPEC. VEHICLE SA08758G3706

Model			2.0 L Non-TURBO			
			AWD			
			LHD		RHD	
			5MT	4AT	5MT	4AT
Curb weight (CW)	Front	kg (lb)	730 (1,610)	745 (1,643)	745 (1,643)	760 (1,676)
	Rear	kg (lb)	615 (1,356)	615 (1,356)	620 (1,367)	620 (1,367)
	Total	kg (lb)	1,345 (2,966)	1,360 (2,999)	1,365 (3,010)	1,380 (3,043)
Maximum permissible axle weight (MPAW)	Front	kg (lb)	920 (2,029)	930 (2,051)	920 (2,029)	930 (2,051)
	Rear	kg (lb)	990 (2,183)	990 (2,183)	990 (2,183)	990 (2,183)
Maximum permissible weight (MPW)	Total	kg (lb)	1,875 (4,134)	1,890 (4,163)	1,875 (4,134)	1,890 (4,167)

Model			2.0 L TURBO			
			AWD			
			LHD		RHD	
			5MT	4AT	5MT	4AT
Curb weight (CW)	Front	kg (lb)	795 (1,753)	815 (1,797)	790 (1,742)	810 (1,786)
	Rear	kg (lb)	635 (1,400)	630 (1,389)	630 (1,389)	630 (1,389)
	Total	kg (lb)	1,430 (3,153)	1,445 (3,186)	1,420 (3,131)	1,440 (3,185)
Maximum permissible axle weight (MPAW)	Front	kg (lb)	975 (2,150)	995 (2,195)	975 (2,150)	975 (2,150)
	Rear	kg (lb)	1,010 (2,225)	1,010 (2,225)	1,010 (2,225)	1,010 (2,225)
Maximum permissible weight (MPW)	Total	kg (lb)	1,950 (4,300)	1,970 (4,344)	1,950 (4,300)	1,970 (4,344)

NOTE:

When any of the following optional parts are installed, add the weight to the curb weight.

Weight of optional parts	ABS (Turbo model)	ABS (Non-Turbo model)	Cruise control	Self-levelizer	Fog lamp	Air conditioner	Sunroof	SRS airbag (Driver & Passenger)	SRS airbag (Side)	Cold weather pack	Cold weather pack (Leather seat)
Front kg (lb)	10 (22)	11 (24)	2 (4)	-1 (-2)	3.6 (7.9)	17 (38)	9 (20)	3 (7)	2 (4.4)	2 (4)	2.6 (5.7)
Rear kg (lb)	-1 (-2)	-1 (-2)	0 (0)	2 (4)	-1 (-2)	-3 (-7)	14 (31)	2 (4)	2 (4.4)	-1 (-2)	4.4 (9.7)
Total kg (lb)	9 (20)	10 (22)	2 (4)	1 (2)	2.6 (5.7)	14 (31)	23 (51)	5 (11)	4 (8.8)	1 (2)	7.0 (15.4)

FORESTER

Specifications

2. AUSTRALIA SPEC. VEHICLE SA08758G3704

Model		2.0 L Non-TURBO		2.0 L TURBO		
		AWD		AWD		
		RHD		RHD		
		5MT	4AT	5MT	4AT	
Unladen mass (UM)	Front	kg (lb)	740 (1,632)	755 (1,665)	810 (1,786)	835 (1,841)
	Rear	kg (lb)	625 (1,378)	625 (1,378)	630 (1,389)	625 (1,378)
	Total	kg (lb)	1,365 (3,010)	1,380 (3,043)	1,440 (3,175)	1,460 (3,219)
Gross vehicle mass (GVM)	Front	kg (lb)	885 (1,951)	910 (2,007)	960 (2,117)	980 (2,161)
	Rear	kg (lb)	990 (2,183)	980 (2,161)	990 (2,183)	990 (2,183)
	Total	kg (lb)	1,875 (4,134)	1,890 (4,167)	1,950 (4,300)	1,970 (4,344)

NOTE:

When any of the following optional parts are installed, add the weight to the unladen mass.

Weight of optional parts	ABS	Cruise control	Self-levelizer	Fog lamp	Air conditioner	Sunroof	SRS airbag (Driver & Passenger)	SRS airbag (Side)	Cold weather pack
Front kg (lb)	10 (22)	2 (4)	-1 (-2)	3.6 (7.9)	17 (38)	9 (20)	3 (7)	2 (4.4)	2.6 (5.7)
Rear kg (lb)	-1 (-2)	0 (0)	2 (4)	-1 (-2)	-3 (-7)	14 (31)	2 (4)	2 (4.4)	4.4 (9.7)
Total kg (lb)	9 (20)	2 (4)	1 (2)	2.6 (5.7)	14 (31)	23 (51)	5 (11)	4 (8.8)	7.0 (15.4)

PRECAUTION

PC

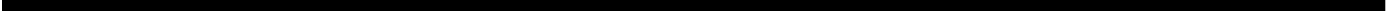

1. Precaution	Page 2
---------------------	-----------



PRECAUTION

Precaution

1. Precaution SA04677

A: PRECAUTION SA04677F59

Please clearly understand and adhere to the following general precautions. They must be strictly followed to avoid minor or serious injury to the person doing the work or people in the area.

1. ABS SA04677F5901

Handle the ABS as a total system. Do not disassemble or attempt to repair individual parts. Doing so could prevent the ABS system from operating when needed or cause it to operate incorrectly and result in injury.

2. BRAKE FLUID SA04677F5902

If brake fluid gets in your eyes or on your skin, do the following:

- Wash out your eyes and seek immediate medical attention.
- Wash your skin with soap and then rinse thoroughly with water.

3. ELECTRIC FAN SA04677F5903

The electric fan may rotate without warning, even when the engine is not on. Do not place your hand, cloth, tools, or other items near the fan at any time.

4. ROAD TESTS SA04677F5904

Always conduct road tests in accordance with traffic rules and regulations to avoid bodily injury and interrupting traffic.

5. AIRBAG SA04677F5905

To prevent bodily injury from unexpected deployment of airbags and unnecessary maintenance, follow the instructions in this manual when performing maintenance on airbag components or nearby, and airbag wiring harnesses or nearby.

To prevent unexpected deployment, perform one of the steps below and then wait at least 20 seconds to discharge electricity before beginning work.

- Step 1: Turn the ignition switch OFF.
- Step 2: Remove the negative battery terminal.

6. AIRBAG DISPOSAL SA04677F5906

To prevent bodily injury from unexpected airbag deployment, do not dispose airbag modules in the same way as other refuse. Follow the special instructions for disposal in this manual. Follow all government regulations concerning disposal of refuse.

7. AIRBAG MODULE SA04677F5907

Adhere to the following when handling and storing the airbag module to prevent bodily injury from unexpected deployment:

- Do not hold harnesses or connectors to carry the module.
- Do not face the bag in the direction that it opens towards yourself or other people.
- Do not face the bag in the direction that it opens towards the floor or walls.

8. AIRBAG SPECIAL TOOLS SA04677F5908

To prevent unexpected deployment, only use special tools.

9. WINDOW SA04677F5909

Always wear safety glasses when working around any glass to prevent glass fragments from damaging your eyes.

10. WINDOW ADHESIVE SA04677F5910

Always use the specified urethane adhesive when attaching glass to prevent it from coming loose and falling, resulting in accidents and injury.

NOTE

NT



1. Note.....	Page 2
--------------	-----------



1. Note SA03676

A: NOTE SA03676A15

This is information that can improve efficiency of maintenance and assure sound work.

1. FASTENER NOTICE SA03676A1501

Fasteners are used to prevent parts from damage and dislocation due to looseness. Fasteners must be tightened to the specified torque.

Do not apply paint, lubricant, rust retardant, or other substances to the surface around bolts, fasteners, etc. Doing so will make it difficult to obtain the correct torque and result in looseness and other problems.

2. STATIC ELECTRICITY DAMAGE SA03676A1502

Do not touch the ECM, connectors, logic boards, and other such parts when there is a risk of static electricity. Always use a static electricity prevention cord or touch grounded metal before conducting work.

3. IGNITION OFF BATTERY SA03676A1503

When removing the battery cables, always be sure to turn the ignition off to prevent electrical damage to the ECM from rush current.

4. SERVICE PARTS SA03676A1504

Use authentic service parts for maximum performance and maintenance, when conducting repairs. Subaru/FHI will not be responsible for poor performance resulting from the use of parts not specified by a genuine dealer.

5. LIFTS AND JACKS SA03676A1505

When using a lift or jack-ridged rack to raise a vehicle, always follow instructions concerning jack-up points and weight limits to prevent the vehicle from falling, which could result in injury. Be especially careful to make sure the vehicle is balanced before raising it.

Support locations

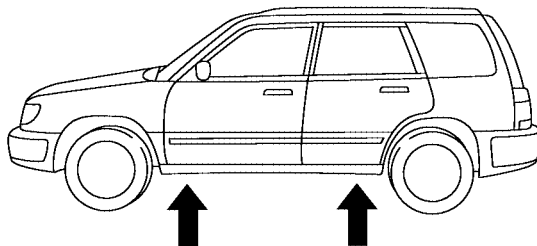

Pantograph jack

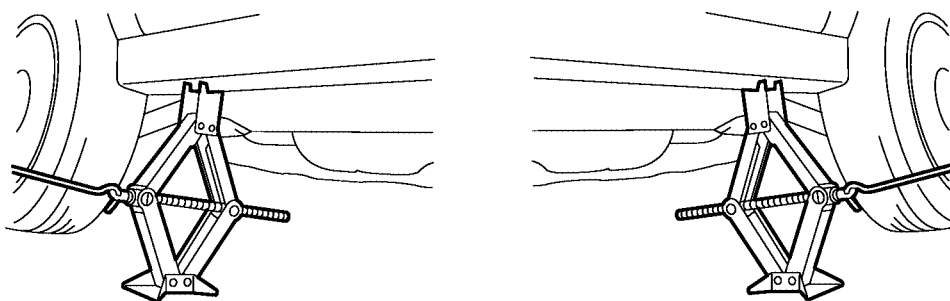

Lift

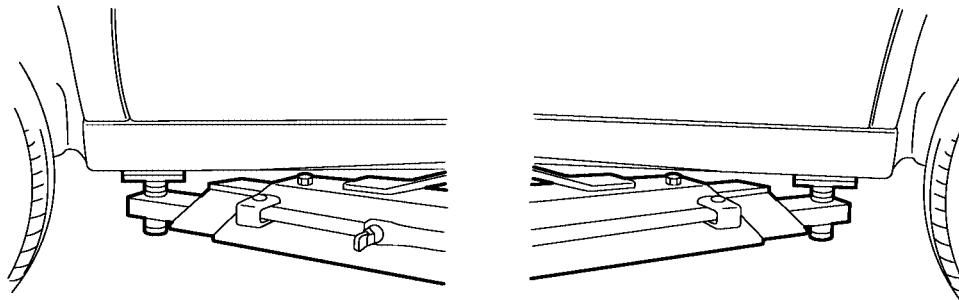

Safety stand

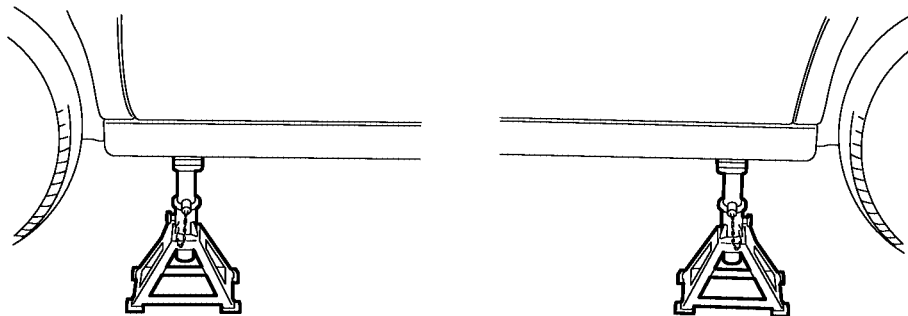

NOTE

Note

Front

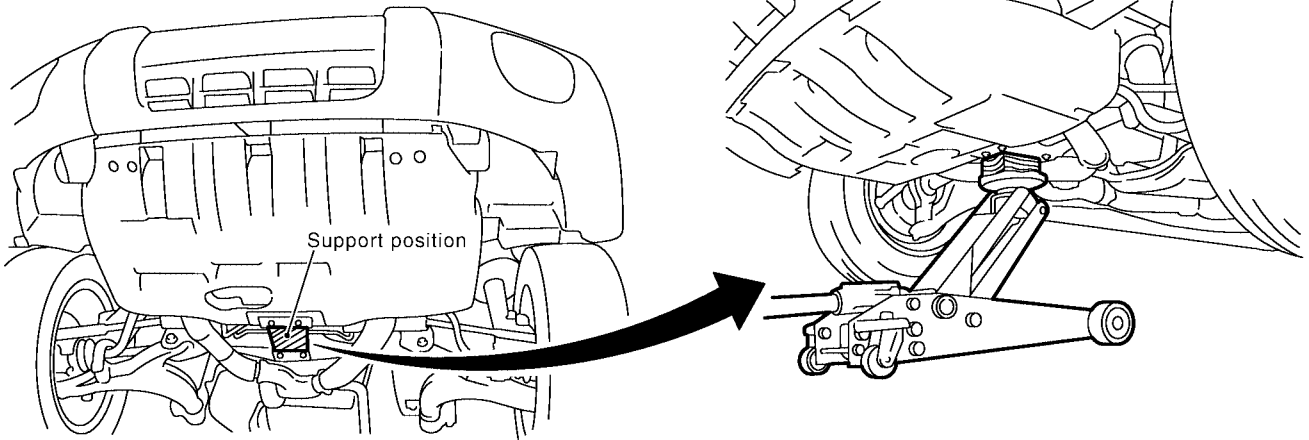

S1M0138A

Rear

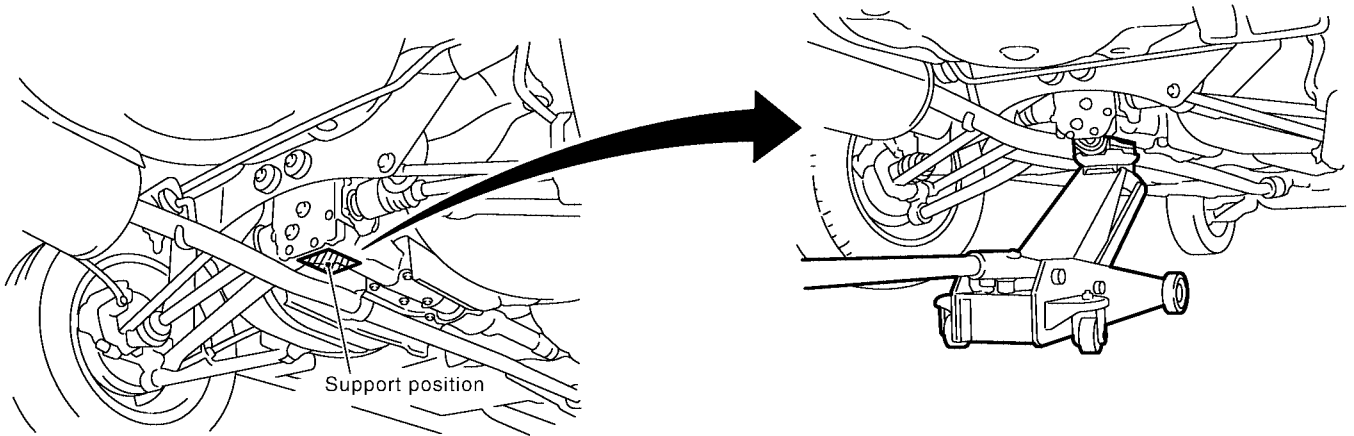

S1M0139A

6. TIE DOWNS SA03676A1506

Tie downs are used when transporting vehicles and when using the chassis dynamo. Attach tie downs only to the specified points on the vehicle.

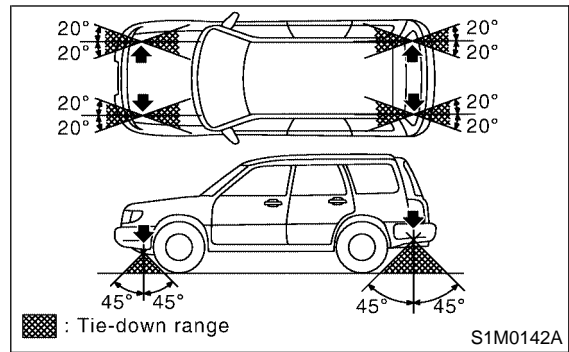
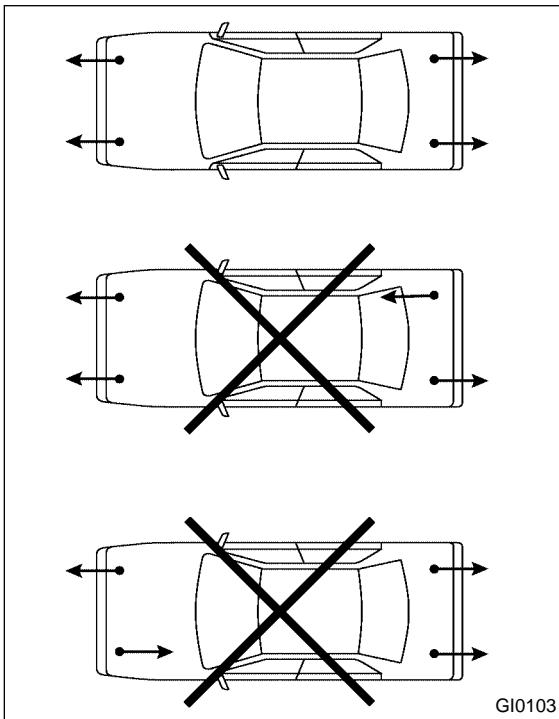
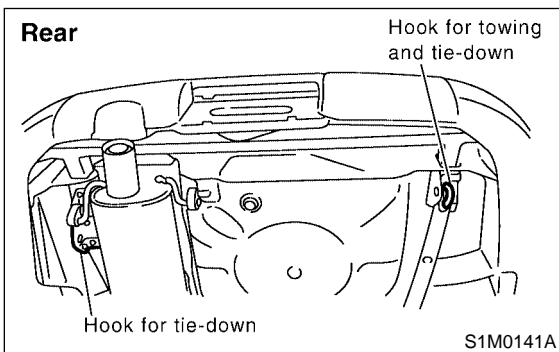
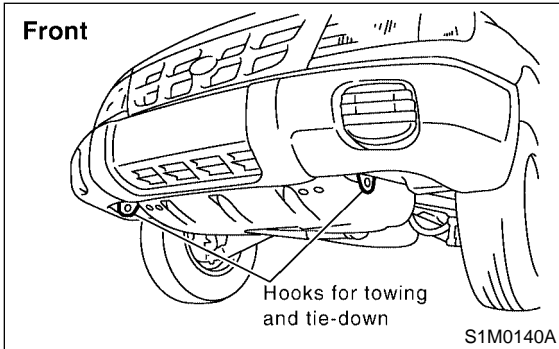

7. TOWING SA03676A1507

Avoid towing vehicles except when the vehicle cannot be driven. For vehicles with AWD, AT, or VTD, use a loader instead of towing. When towing other vehicles, to prevent excessive weight from damaging the hook or vehicle:

- Do not tow other vehicles with a front towing hook.
- Make sure the vehicle towing is heavier than the vehicle being towed.

8. TRAINING SA03676A1508

For information about training, contact a dealer or agent.

9. GENERAL SCAN TOOL SA03676A1509

Using general scan tools will greatly improve efficiency of repairing engine electronic controls. The Subaru Select Monitor can be used to diagnose the engine and also the ABS, and other parts.

NOTE

Note

MEMO:

IDENTIFICATION

ID



1. Identification	Page 2
-------------------------	-----------



IDENTIFICATION

Identification

1. Identification SA06679

A: IDENTIFICATION SA06679F70

1. IDENTIFICATION NUMBER AND LABEL LOCATIONS SA06679F7001

The VIN (Vehicle Identification Numbers) is used to classify the vehicle.
Positioning of the plate label for identification

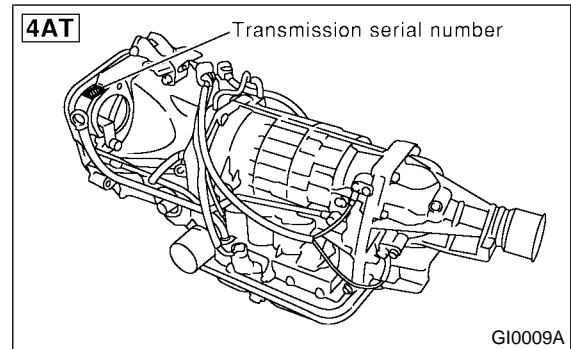
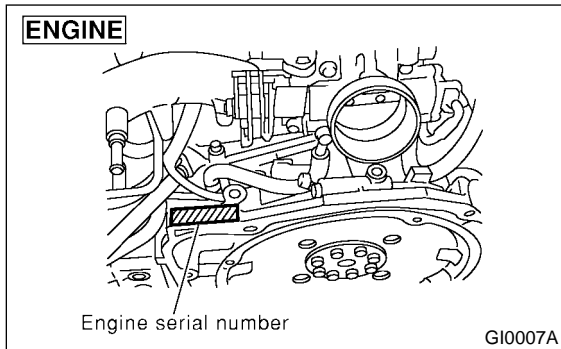
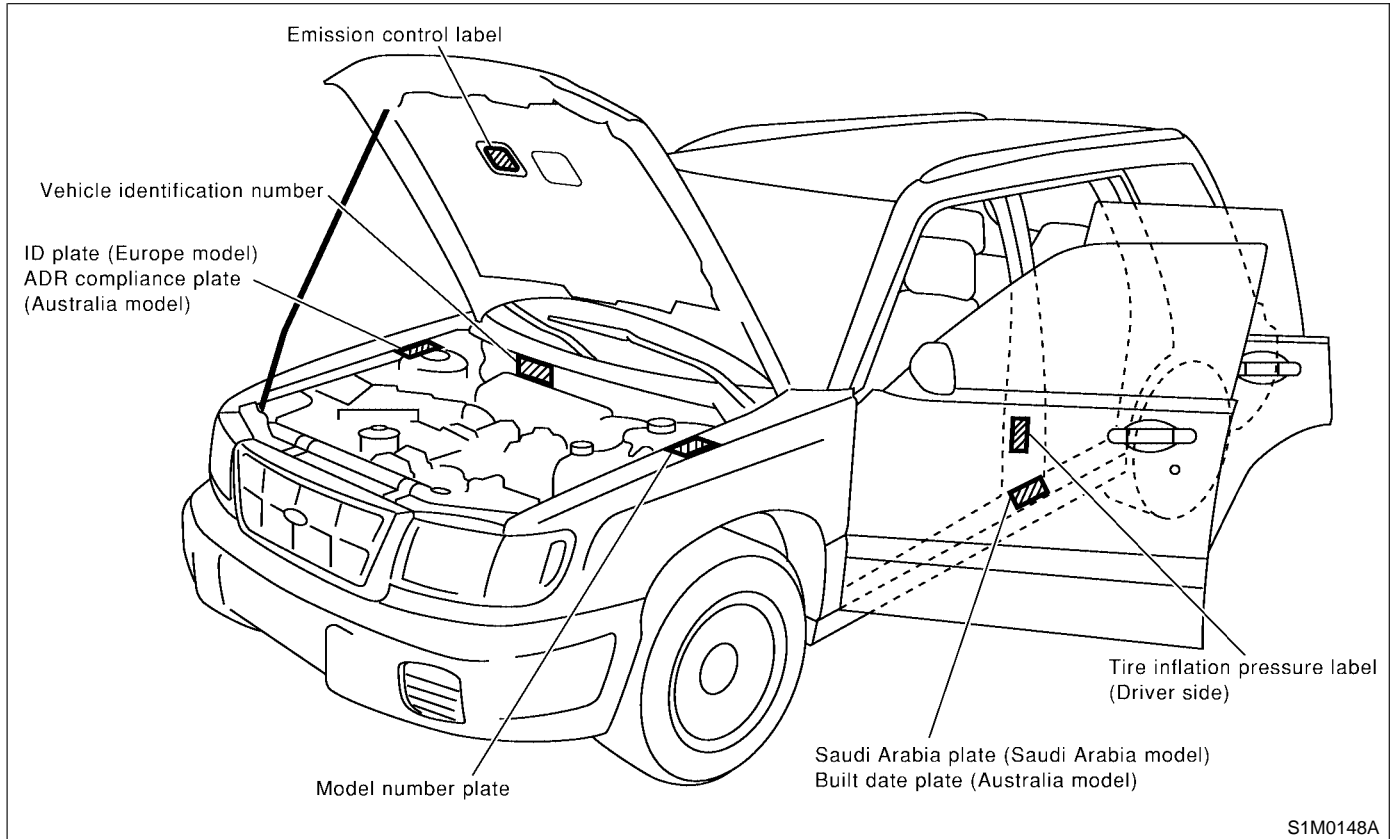

IDENTIFICATION

Identification

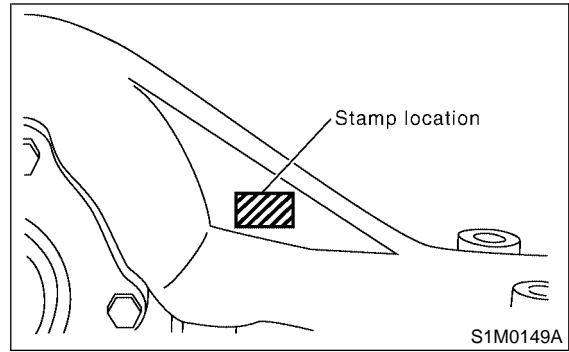
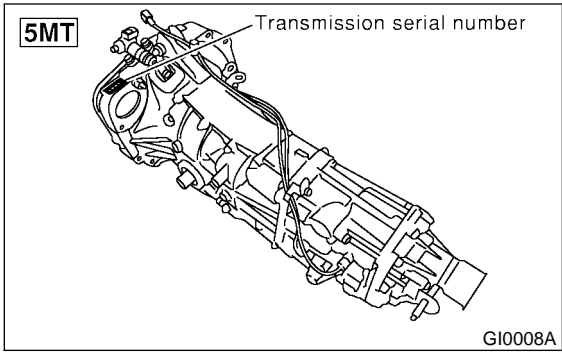

Model number plate

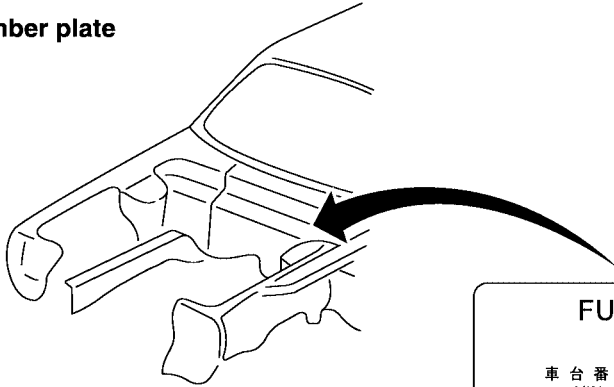

FUJI HEAVY INDUSTRIES LTD.

型式

車台番号 VIN **JF1BD4LG9RG002001**

○アプライトモデル applied model **BD4AL3G** オプションコード option code **E0** ○

トリムコード trim code **410** エンジン型式 engine type **EJ20ENMABA**

外装飾コード color code **230** ミッション型式 transmission type **TM752RGAAA**

富士重工業株式会社

GI0011A

IDENTIFICATION

Identification

2. MEANING OF V.I.N. SA06679F7002

The meaning of the VIN is as follows:

- **Europe, Australia and General (Except GCC)**

]JF1SF5LJ31G002001[

The starting and ending brackets (] [) are stop marks.

Digits	Code	Meaning	Details
1 to 3	JF1	Manufacturer body area	JF1: Passenger car, FHI made JF2: MPV, FHI made
4	S	Car line	Forester
5	F	Body type	F: Wagon
6	5	Displacement	5: 2.0 L AWD
7	L	Steering position	K: RHD (Right-hand drive) L: LHD (Left-hand drive)
8	J	Engine & transmission	J: SOHC MPI Full-time AWD 5-speed MT R: SOHC MPI 4-speed AT D: DOHC Turbo Full-time AWD 5-speed MT P: DOHC Turbo 4-speed AT
9	3	Drive type	3: Full-time AWD 5-speed MT single range 4: Full-time AWD 5-speed MT dual range 5: Full-time AWD 4-speed AT
10	1	Model year	1: 2001MY 2: 2002MY
11	G	Factory location	G: FHI (Gunma)
12 to 17	002001	Serial number	

- **GCC countries (Saudi Arabia, etc.)**

]JF1SF53MX1J002001[

The starting and ending brackets (] [) are stop marks.

Digits	Code	Meaning	Details
1 to 3	JF1	Manufacturer body area	JF1: Passenger car, FHI made
4	S	Car line	Forester
5	F	Body type	E: Wagon
6	5	Displacement	5: 2.0 L AWD
7	3	Grade	3: BASE 5: NA SPRT
8	M	Restraint	M: Manual belts, dual airbag
9	X	Check digit	
10	1	Model year	1: 2001MY 2: 2002MY
11	J	Transmission type	H: Full-time AWD 4-speed AT J: Full-time AWD 5-speed MT dual range
12 to 17	002001	Serial number	

3. MODEL NUMBER PLATE SA06679F7003

The model number plate indicates: the applied model, the option code, the trim code, the engine type, the transmission type, and the exterior color code. This information is helpful when placing orders for parts.
SF9CL7R

Digits	Code	Meaning	Details
1	S	Series	Forester
2	F	Body style	F: Wagon
3	9	Engine displacement Drive system Suspension system	5: 2.0 L AWD 9: 2.5 L AWD
4	C	Minor change	2001MY
5	L	Destination	K: Right-hand drive for general market L: Left-hand drive for general market Y: For United States, Canada
6	7	Grade	2: BASE 3: HUNTER Ver. 4: NA SPORT 5: TYPES
7	R	Transmission, fuel feed system	E: DOHC MPI 4-speed AT P: DOHC MPI Turbo 4-speed AT D: DOHC MPI Turbo center differential AWD J: SOHC MPI center differential AWD R: SOHC MPI 4-speed AT

The engine and transmission type are as follows:

- **Engine**

EJ20DAXBBB

Digits	Code	Meaning	Details
1 and 2	EJ	Engine type	EJ: 4 cylinders
3 and 4	20	Displacement	20: 2.0 L 25: 2.5 L
5	D	Fuel feed system	1: D-MPI SOHC-A 2: D-MPI SOHC-B 4: MPI DOHC 5: MPI Turbo
6	A	Detailed specifications	Used when ordering parts. See the parts catalog for details.
7	X	Transmission	W: AWD MT X: AWD AT
8 to 10	BBB	Detailed specifications	Used when ordering parts. See the parts catalog for details.

IDENTIFICATION

Identification

● Transmission

TZ1A3ZS3AA

Digits	Code	Meaning	Details
1	T	Transmission	T: Transmission
2	Z	Transmission type	Y: Full-time AWD MT center differential Z: Full-time AWD AT MPT
3 and 4	1A	Classification	75: MT 1A: New AT
5	3	Series	3: AT 5: MT
6	Z	Transmission specifications	V: Full-time AWD 5-speed MT with viscous coupling center differential single range X: Full-time AWD 5-speed MT with viscous coupling center differential dual range Z: Full-time AWD 4-speed AT with MPT
7 to 10	AAA	Detailed specifications	Used when ordering parts. See the parts catalog for details.

● Rear differential 1

VA1RFF

Digits	Code	Meaning	Details
1	V	For AWD	V: AWD
2	A	Type	A: A type
3	1	Hypoid gear diameter	1: 152 dia. 2: 160 dia.
4	R	Installation position	R: Rear
5	F	Reduction gear ratio	F: 4.444
6	F	Specification differences	F: Case A

● Rear differential 2

T1

Code	Reduction gear ratio	LSD
T1	3.900	No
T2	4.111	No
TP	4.444	No
BK	4.111	No
BP	4.111	Strengthened type
BL	4.444	Strengthened type
VB	3.700	No

RECOMMENDED MATERIALS

RM

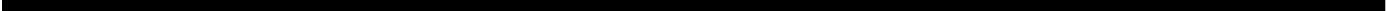

	Page
1. Recommended Materials	2



1. Recommended Materials SA05678

A: RECOMMENDED MATERIALS

SA05678G22

1. GENERAL SA05678G2201

To insure the best performance, always use the specified oil, gasoline, adhesive, sealant, etc. or that of equivalent quality.

2. FUEL SA05678G2202

Always use a gasoline of the same or higher octane value than specified in the owner's manual. Ignoring the specifications below will result in damage or poor operation of the engine and fuel injection system. Use the specified gasoline to correct performance.

- **Unleaded gasoline**

Use unleaded gasoline and not leaded gasoline on vehicles with catalytic converter installed to reduce air pollution. Using leaded gasoline will damage the catalytic converter.

- **Leaded gasoline**



On vehicles without catalytic converter, use gasoline with an octane value of 90 RON or higher.

RECOMMENDED MATERIALS

Recommended Materials

3. LUBRICANTS SA05678G2203

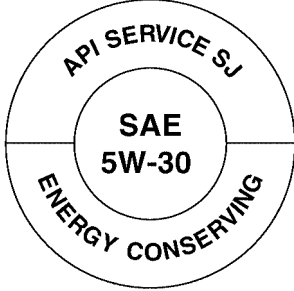
Use either the lubricants in the table below or equivalent lubricants. See the table below to choose the correct SAE viscosity.

Lubricant	Recommended			Alternative
	API Spec.	CCMC Spec.	ACEA Spec.	
Engine oil	SJ Grade "Energy conserving"  G10001  G10002	G4 or G5	A1, A2 or A3	API: SH or SG
Manual transmission oil	GL-5	—	—	—
Front differential	GL-5	—	—	—
Rear differential	GL-5	—	—	—

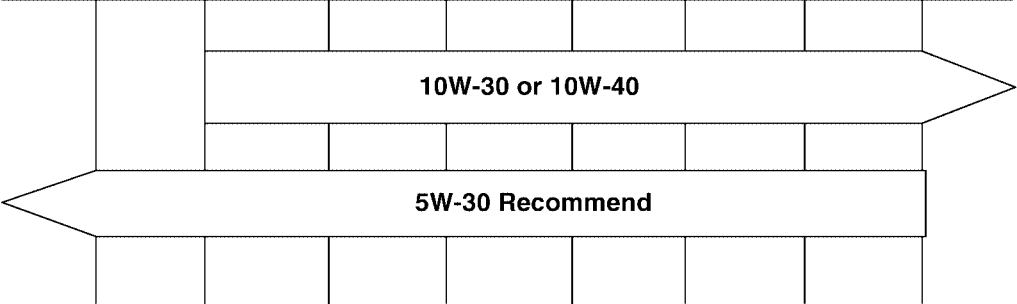
SAE viscosity	SAE viscosity No. and applicable temperature SAE J300																		
Engine oil	<table style="width: 100%; border-collapse: collapse;"> <tr> <td style="text-align: center;">(°C)</td> <td style="text-align: center;">-30</td> <td style="text-align: center;">-20</td> <td style="text-align: center;">-10</td> <td style="text-align: center;">0</td> <td style="text-align: center;">10</td> <td style="text-align: center;">20</td> <td style="text-align: center;">30</td> <td style="text-align: center;">40</td> </tr> <tr> <td style="text-align: center;">(°F)</td> <td style="text-align: center;">-22</td> <td style="text-align: center;">-4</td> <td style="text-align: center;">14</td> <td style="text-align: center;">32</td> <td style="text-align: center;">50</td> <td style="text-align: center;">68</td> <td style="text-align: center;">86</td> <td style="text-align: center;">104</td> </tr> </table>  <p style="text-align: right; margin-top: 20px;">G10003A</p>	(°C)	-30	-20	-10	0	10	20	30	40	(°F)	-22	-4	14	32	50	68	86	104
(°C)	-30	-20	-10	0	10	20	30	40											
(°F)	-22	-4	14	32	50	68	86	104											

RECOMMENDED MATERIALS

Recommended Materials

SAE viscosity	SAE viscosity No. and applicable temperature SAE J300								
Manual transmission oil	(°C)	-30	-20	-10	0	10	20	30	40
	(°F)	-22	-4	14	32	50	68	86	104
Rear differential	90								
	85W								
	80W								
	75W-90								
GI0004A									
Front differential	(°C)	-30	-20	-10	0	10	20	30	40
	(°F)	-22	-4	14	32	50	68	86	104
90									
85W									
80W									
80W-90									
GI0005A									

4. FLUID SA05678G2204

Use the fluids specified in the table below. Do not mix two different kinds or makes of fluid.

Fluid	Recommended	Alternative	Remarks
Automatic transmission fluid	DEXRON III	—	
Power steering fluid	DEXRON III	—	
Brake fluid	FMVSS No. 116 DOT3	FMVSS No. 116 DOT4	
Clutch fluid	FMVSS No. 116 DOT3	FMVSS No. 116 DOT4	

5. COOLANT SA05678G2205

Use genuine coolant to protect the engine.

Coolant	Recommended	Item number	Alternative
Coolant	SUBARU coolant	000016218	None
Water for dilution	Distilled water	—	Tap water

RECOMMENDED MATERIALS

Recommended Materials

The table below shows the ratio of coolant to distilled water.

Coolant Specifications							
Lowest anticipated atmospheric temperature	SUBARU coolant-to-*water ratio (Volume) %	Specification gravity					Freezing point
		at 10°C (50°F)	at 20°C (68°F)	at 30°C (86°F)	at 40°C (104°F)	at 50°C (122°F)	
Above -30°C (-22°F)	50 — 50	1.084	1.079	1.074	1.068	1.062	-36°C (-33°F)
Above -15°C (5°F)	30 — 70	1.050	1.049	1.042	1.037	1.032	-16°C (3°F)

*: It is recommended that distilled water be used.

6. REFRIGERANT SA05678G2206

Standard air conditioners on Subaru vehicles use HFC134a refrigerant. Do not mix it with other refrigerants. Also, do not use any air compressor oil except for ZXL200PG and DENSO OIL 9.

Air conditioner	Recommended	Item number	Alternative
Refrigerant	HFC134a	—	None
Compressor oil	ZXL200PG	—	None

7. GREASE SA05678G2207

Use the grease and supplementary lubricants shown in the table below.

Grease	Application point	Recommended	Item number	Alternative
Supplementary lubricants	<ul style="list-style-type: none"> ● O2 sensor ● Bolts, etc. 	SUBARU CRC	004301003	—
Grease	MT main shaft	FX clutch grease	000040901	—
	Clutch master cylinder push rod	Slicolube G-40M	004404003	—
	<ul style="list-style-type: none"> ● Steering shaft bearing ● Gear shift bush 	SUNLIGHT2	003602010	—
	Steering gear box	Valiant grease M-2	003608001	—
	Disc brake	Niglube RX-2	003606000 or 725191040	—
	Drum brake	Molykote No. 7439	72519460	—
	<ul style="list-style-type: none"> ● Brake pad ● Brake shoe 	Molykote AS-880N	26298AC000	—
	Front axle SFJ	SSG-6003	28093TA000	—
	Front BJ	NTG 2218	28093AA000	—
	Rear axle BJ	Molykote No. 2	723223010	—
	Rear axle EBJ (Turbo-model)	NTG 2218	28093AA000	—
	Rear axle DOJ	VU-3A702	23223GA050	—
	<ul style="list-style-type: none"> ● Control cable ● Throttle linkage ● Water pump ● Door latch ● Door striker 	Slicolube G-30M	004404002	—

RECOMMENDED MATERIALS

Recommended Materials

8. ADHESIVES SA05678G2210

Use the adhesives shown in the table below, or equivalent.

Adhesive	Application point	Recommended	Item number	Alternative
Adhesive	Windshield and body	Essex Chemical Crop's Urethane E	—	Sunstar 580
	Weatherstrip, rubber parts	Cemedine 5430L	—	3M's EC-1770 EC-1368
	Soft vinyl	Cemedine 540	—	3M's EC-776 EC-847 or EC-1022 (Spray type)
	Momentary sealant	Cemedine 3000 RS-300	—	Armstrong's Eastman 910

9. SEAL MATERIAL SA05678G2209

Use seal material shown in the table below, or equivalent.

Seal material	Application point	Recommended	Item number	Alternative
	Engine case	Three Bond 1215B	004403007	Dow Corning's No. 7038
	Transmission	Three Bond 1217B	K0877YA020	—
	Rear differential	Three Bond 1324	004403042	—
	Rear differential	Three Bond 1105	004403010	Dow Corning's No. 7038
	Weatherstrip	Starcalking B-33A	000018901	Butyl Rubber sealant
	Steering adjusting screw	Three Bond 1102	004403006	—
	SOHC cam cap	Three Bond 1280B	K0877YA018	—

PRE-DELIVERY INSPECTION

PI



1. Pre-delivery Inspection.....	Page 2
---------------------------------	-----------



1. Pre-delivery Inspection SA09719

A: GENERAL SA09719G23

The purposes of the pre-delivery inspection (PDI) are as follows.

- Remove the additional parts used for ensuring the vehicle quality during transportation and restore the vehicle to its normal state.
- Check if the vehicle before delivery is in a normal state.
- Check for any damage or missing parts that may have taken place during transportation or storage.
- Make sure to provide a complete vehicle to the customer.

Because of the above reasons, all dealerships must always carry out the PDIs before delivering a vehicle.

In addition, all franchised shops and PDI centers must check the status of every vehicle received to identify who is responsible for any possible defects.

B: PDI PROCEDURE SA09719G50

Follow the procedures shown in the table below.

Static Checks Just After Vehicle Receipt

Step	Check point
1. Appearance check	(1) If the vehicle is covered with protective coating, visually check the vehicle body for damage and dents. If the protective coating has been removed, visually check the body paints for small areas of damage or stains. (2) Visually check the glass and light lenses for any damage and cracks or excessive gaps to the body sheet metal. (3) Visually check the plated parts for any damage.
2. Tire check	(1) Check the tires for damage, abnormal conditions, and dents on the wheels. (2) Check the tire air pressure.
3. Fuse installation	(1) If the vehicle is about to be delivered to the customer, attach a room lamp fuse.
4. Check the doors for lock/unlock and open/close operations.	(1) Using the key, check if the door can be locked and unlocked normally. (2) Open and close the all doors to see that there are no abnormal conditions.
5. Operation check of trunk lock release lever	(1) Operate the trunk lock release lever to check that the trunk opens normally.
6. Check the rear gate for lock/unlock and open/close operations.	(1) Using the key, check if the door can be locked and unlocked normally. (2) Open and close the doors to see that there are no abnormal conditions.
7. Operation check of fuel lid opener lock release lever	(1) Operate the fuel lid opener to check that the fuel lid is unlocked normally.
8. Operation check of child lock system.	(1) Check that the child lock operates normally.
9. Accessory check	Check the following accessories are provided: <ul style="list-style-type: none"> ● Owner's manual ● Warranty booklet ● Service booklet ● Spare key ● Jack ● Tool set ● Spare tire
10. Operation check of hood lock release system	(1) Operate the hood lock release lever to check that the hood opens normally.
11. Connection of air conditioner harness	(1) If the vehicle is about to be delivered to the customer, connect the air conditioner harness.
12. Battery	(1) Check the battery for any abnormal conditions such as rust and trace of battery fluid leaks.
13. Brake fluid	(1) Check the fluid amount.
14. Engine oil	(1) Check the oil amount.
15. Transmission fluid	(1) Check the fluid amount. (2) For AT, check the front differential oil.
16. AT front differential oil	(1) Check the AT front differential oil amount.
17. Coolant	(1) Check the coolant amount.
18. Clutch fluid	(1) Check the clutch fluid amount.
19. Window washer fluid	(1) Check the window washer fluid amount.
20. Hood latch check	(1) Check that the hood is closed and latched securely.
21. Keyless entry system	(1) Check that the keyless entry system operates normally.
22. Seat	(1) Check the seat surfaces for smears or dirt. (2) Check the seat installation conditions and functionality.
23. Seat belt	(1) Check the seat belt installation conditions and functionality.
24. Wheel alignment	(1) Check that the wheel alignments are properly adjusted.

PRE-DELIVERY INSPECTION

Pre-delivery Inspection

Checks with the Engine Running

Step	Check point
1. Read memory and test mode connectors	(1) Read memory and test mode connectors
2. Starting condition	(1) Start the engine and check that the engine starts smoothly.
3. Exhaust system	(1) Check that the exhaust noise is normal and no leaks are found.
4. Indicator light	(1) Check that all the indicator lights operate normally.
5. Clock	(1) Check that the clock operate normally.
6. Radio	(1) Check that the radio system operates normally.
7. Cigarette lighter	(1) Check that the cigarette lighter operates normally.
8. Lighting system	(1) Check that the lighting systems operate normally.
9. Window washer	(1) Check that the window washer system operates normally.
10. Wiper	(1) Check that the wiper system operates normally.
11. Power window operation check	(1) Check the power window for correct operations.

Dynamic Test with the Vehicle Running

Step	Check point
1. Brake test	(1) Check that the foot brake operates normally.
2. Parking brake	(1) Check that the parking brake operates normally.
3. AT shift control	(1) Check the AT shift patterns are correct.
4. Heater & ventilation	(1) Check that the heater & ventilation system operates normally.
5. Air conditioner	(1) Check that the air conditioner operates normally.
6. Cruise control	(1) Check that the cruise control system operates normally.

Checks after Dynamic Test

Step	Check point
1. ATF level	(1) Check that the ATF level is normal.
2. Power steering fluid level	(1) Check that the power steering fluid level is normal.
3. Fluid leak check	(1) Check for fluid/oil leaks.
4. Water leak check	(1) Spray the vehicle with water and check for water leaks.
5. Appearance check 2	(1) Remove the protective coating (if any). (2) Check the body paints for damage and smears. (3) Check the plated parts for damage and rust.

1. APPEARANCE CHECK SA09719G5001

- If the vehicle is covered with protective coating, visually check the vehicle body for damage and dents.
- If there is no protective coating, check the body paints for small areas of damage or stains and repair as necessary.
- Check the window glass, door glass, and lights for any cracks or damage and repair or replace the parts as necessary.
- Check the plated parts, such as the grilles and door knobs, for damage or loss of gloss and repair or replace the parts as necessary.

2. TIRE CHECK SA09719G5002

- Check the tire outer faces for any damage.
- Check the tire air pressure by referring to the following table.

Tire size		Tire inflation pressure kPa (kg/cm ² , psi)	
		Front	Rear
Non-TURBO	P205/70R15 95S*	Light load	200 (2.0, 29) / 190 (1.9, 28)
	205/70R15 95H 205/70R15 95Q (SNOW)	Full load	200 (2.0, 29) / 250 (2.5, 36)
TURBO	P215/60R16 94H*	Light load	200 (2.0, 29) / 190 (1.9, 28)
	215/60R16 95V 215/60R16 95Q (SNOW)	Full load	200 (2.0, 29) / 250 (2.5, 36)

*: Australia model

NOTE:

- After inspecting and adjusting the tire pressure, be sure to put the valve cap back.
- When towing, adjust the tire inflation pressures as follows:
Front: 200 kPa (2.0 kg/cm², 29 psi)
Rear: 280 kPa (2.8 kg/cm², 41 psi)

3. FUSE INSTALLATION SA09719G5010

A vehicle just delivered has no fuses for the room lamp circuit to prevent battery discharge. Attach a 15 A fuse as shown in the figure.

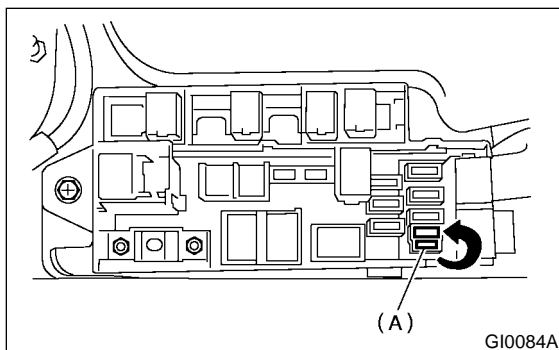

4. CHECK THE DOOR OPERATIONS, LOCK/UNLOCK AND OPEN/CLOSE, AS FOLLOWS. SA09719G5003

Using the key, lock and unlock the door several times to check for normal operation. Open and close the door several times for smooth movement.

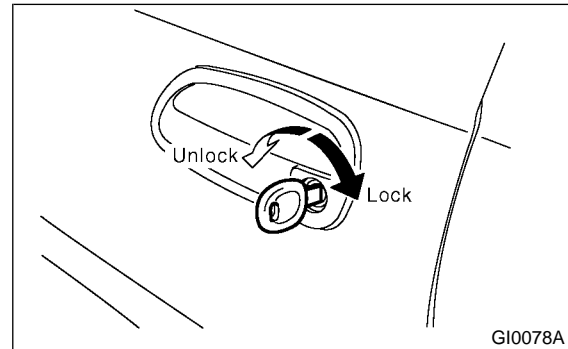

● Vehicles with manual door locks:

Sit in the driver seat, close the door completely, and move the lock lever to the lock position. Then, pull the inside door handle to ensure the door will not open.

● Vehicles with power door locks:

Sit in the driver seat, close the driver's door completely, and place the door lock knob (A) to the lock position. Then pull the all inside door handles (B) to ensure that the all doors will not open. For other doors, place the lock levers to the lock positions and then pull the inside door handles to ensure that the doors will not open.

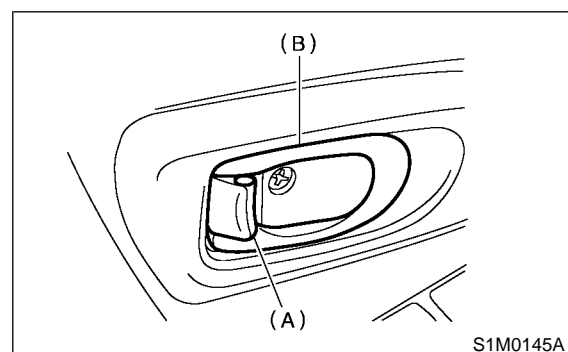

5. OPERATION CHECK OF TRUNK LOCK RELEASE LEVER SA09719G5005

Operate the trunk lock release lever and verify that the trunk lid opens.

PRE-DELIVERY INSPECTION

Pre-delivery Inspection

6. OPERATION CHECK OF REAR GATE LOCK RELEASE LEVER

SA09719G5006

- Operate the rear gate lock release lever and verify that the rear gate is unlocked and opened smoothly.
- Using the key, lock and unlock the door several times to check for normal operation. Open and close the door several times for smooth movement.

7. OPERATION CHECK OF FUEL LID OPENER LOCK RELEASE LEVER

SA09719G5007

Operate the fuel lid opener and verify that the fuel lid opens normally. Check that the filler cap is securely closed.

8. CHECK THE OPERATION OF CHILD SAFETY LOCKS

SA09719G5052

- 1) Set the child safety lock on both rear doors to the lock positions.
- 2) Close the rear doors completely.
- 3) Check that the lock levers of the rear doors are in the unlock positions. Then, pull the inside door handles of the rear doors to ensure that the doors will not open.
- 4) Next, pull the outside door handles of the rear doors to ensure that the doors will open.
- 5) Repeat the above steps two or three times.

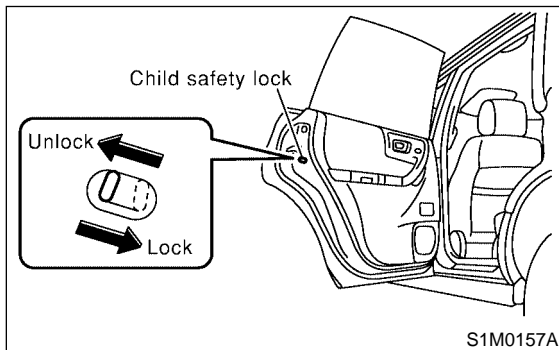

9. ACCESSORY CHECK

SA09719G5008

Check that the following accessories are provided in the luggage compartment or cargo area.

- Owner's manual
- Warranty booklet
- Service booklet
- Spare key
- Jack
- Tool set
- Spare tire

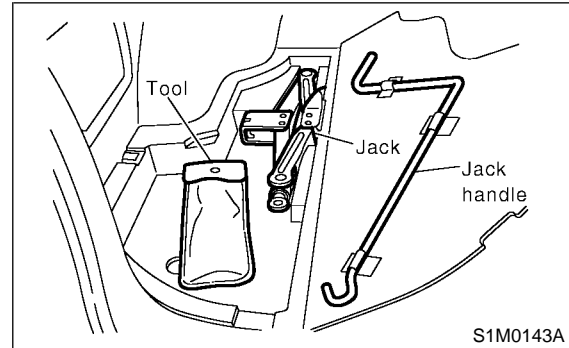

10. OPERATION CHECK OF HOOD LOCK RELEASE SYSTEM

SA09719G5009

Unlatch and open the hood while checking that no abnormal conditions are found. Then, support the hood with the hood stay.

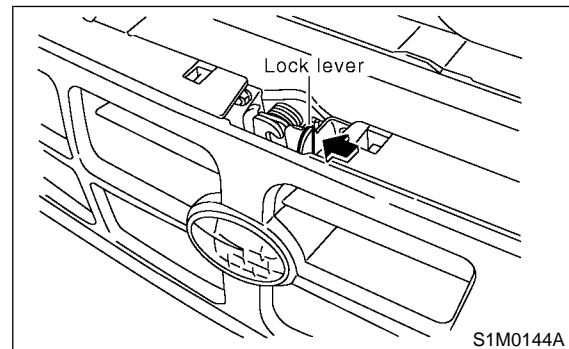
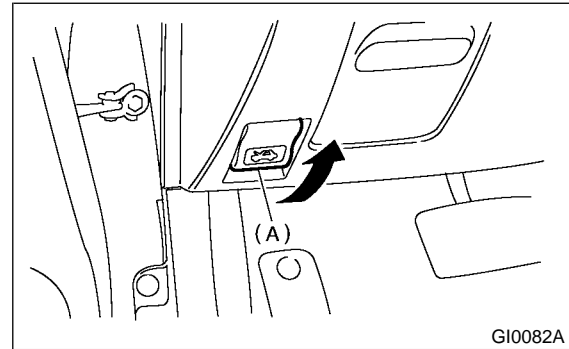

11. CONNECTION OF AIR CONDITIONER HARNESS SA09719G5011

A vehicle just delivered has its air conditioner harness disconnected to protect the air conditioner compressor. Connect the harness as shown in the figure.

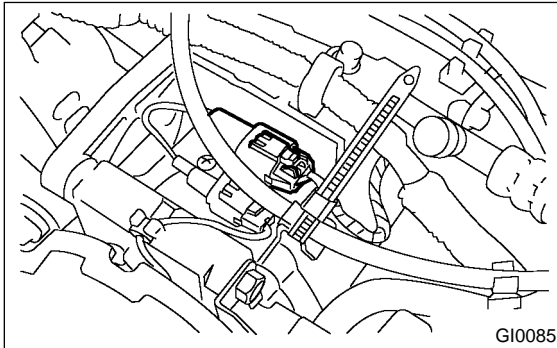

12. BATTERY SA09719G5012

Check the battery terminals to make sure that no rust or corruptions due to fluid leaks are found. Check that the battery tent is securely tightened.

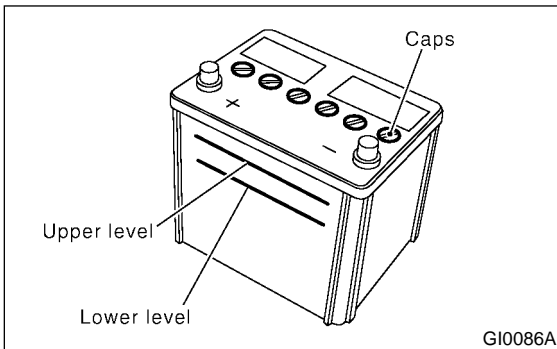

13. BRAKE FLUID SA09719G5013

Check the brake fluid amount. If the amount is insufficient, carry out a brake line test to identify brake fluid leaks and check the brake operation. After that, refill the brake fluid tank with the specified type of fluid.

14. ENGINE OIL SA09719G5014

Check the engine oil amount. If the amount is insufficient, check that no leaks are found. Then, add the necessary amount of the specified engine oil.

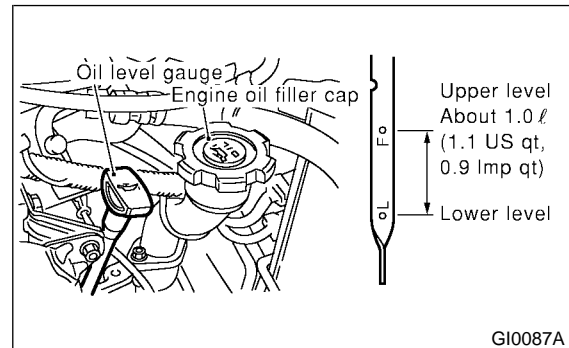

15. TRANSMISSION FLUID SA09719G5015

Check the transmission fluid amount. If the amount is insufficient, check that no leaks are found. Then, add the necessary amount of the specified fluid.

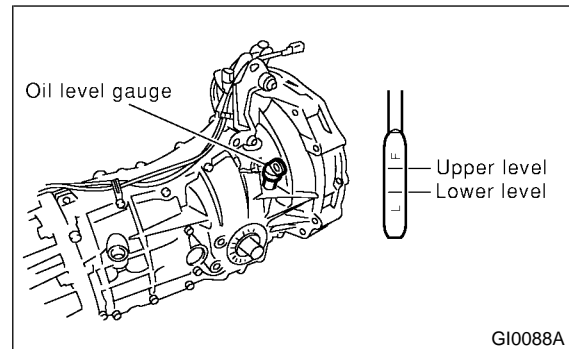

16. AT FRONT DIFFERENTIAL OIL SA09719G5016

Check the AT front differential oil amount. If the amount is insufficient, check that no leaks are found. Then, add the necessary amount of the specified AT front differential oil.

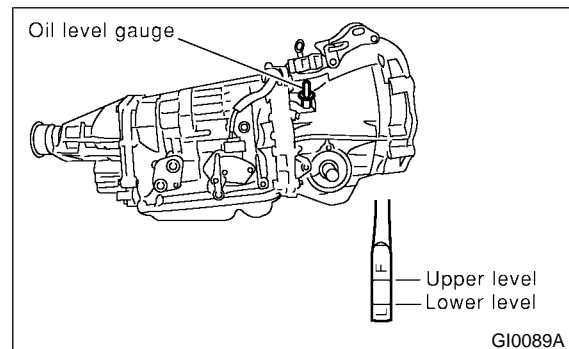

PRE-DELIVERY INSPECTION

Pre-delivery Inspection

17. COOLANT SA09719G5017

Check the coolant amount on the reservoir. If the amount is insufficient, check that no leaks are found. Then, add the necessary amount of coolant with the specified concentration.

18. CLUTCH FLUID SA09719G5018

Check the clutch fluid amount. If the amount is insufficient, check that no leaks are found. Then, add the necessary amount of the specified fluid.

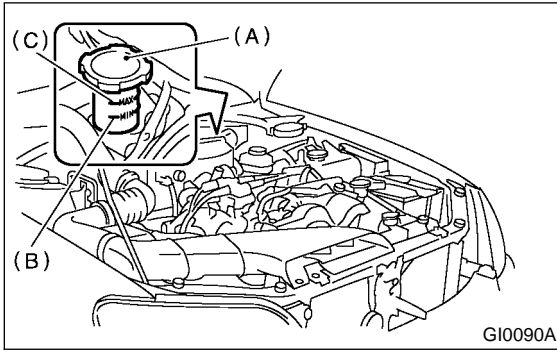

19. WINDOW WASHER FLUID SA09719G5019

Check the window washer fluid amount. If the amount is insufficient, check that no leaks are found. Then, add the necessary amount of washer fluid commercially available.

20. HOOD LATCH CHECK SA09719G5020

Retract the hood stay and close the hood. Check that the hood is securely latched.

21. KEYLESS ENTRY SYSTEM SA09719G5021

Check the keyless entry system operations as follows.

- Remove the key from the ignition switch and close all the doors including rear gate (wagon).
- Press the “LOCK” button on the transmitter momentarily once and check if all the doors are locked and the hazard light flashes ones.

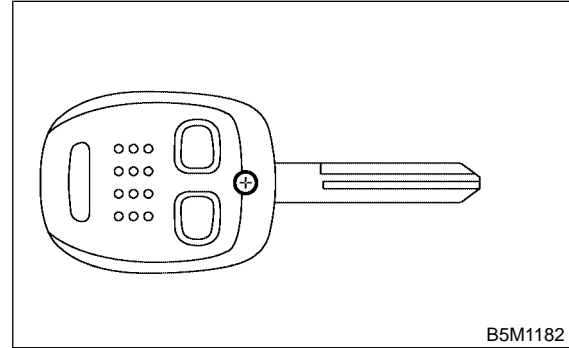

- Press the “OPEN” button on the transmitter momentarily once and check if the driver’s door is unlocked, the hazard light flashes twice and the dome light illuminates.
- Close all doors and rear gate, press the “LOCK” button of the transmitter. Press the “OPEN” button of the transmitter and wait for 30 seconds. Check that all doors and the rear gate are automatically locked again.

22. SEAT SA09719G5023

Check that each seat provides full functionality in sliding and reclining. Check all available functions of the rear seat such as a trunk-through center arm rest.

23. SEAT BELT SA09719G5024

Pull out the seat belt and then release it. Check that the belt webbing retracts smoothly.

24. WHEEL ALIGNMENT SA09719G5026

Check the wheel alignments. <Ref. to FS-6 Wheel Alignment.> and <Ref. to RS-7 Wheel Alignment.>

25. READ MEMORY AND TEST MODE CONNECTORS SA09719G5050

Turn the ignition switch to ON and check that the check-engine light starts blinking. If the light blinks, return the ignition key to LOCK and disconnect the test mode connector. Then, turn the ignition key to ON again. If the check-engine light blinks at that time in spite of the disconnected test mode connector, carry out an engine diagnosis.

With OBD model

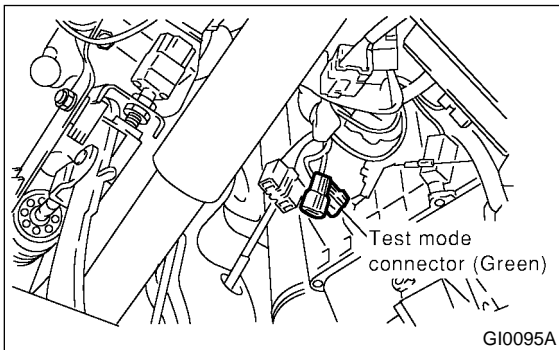

Without OBD model

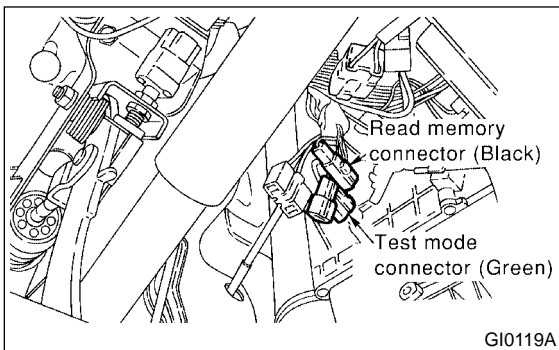

26. STARTING CONDITION SA09719G5029

Start the engine and check that the engine starts smoothly. If any battery voltage problems are found, recharge or replace the battery. If any abnormal noises are observed, immediately stop the engine and check and repair the necessary components.

27. EXHAUST SYSTEM SA09719G5030

Listen to the exhaust noise to see if no abnormal noises are observed.

28. INDICATOR LIGHT SA09719G5031

Check that all the indicator lights are off.

29. CLOCK SA09719G5032

Check the clock for normal operations and enough accuracy.

30. RADIO SA09719G5033

Check the radio for full functionality and normal noise level. Also check the CD unit operations.

31. CIGARETTE LIGHTER SA09719G5034

Check that the cigarette lighter operations.

32. LIGHTING SYSTEM SA09719G5035

- Check the headlight operations.
- Check the brake light operations.
- Check the other lights for normal operations.

33. WINDOW WASHER SA09719G5036

Check that the window washer system injects washer fluid to the specified area of the windshield shown in the figure.

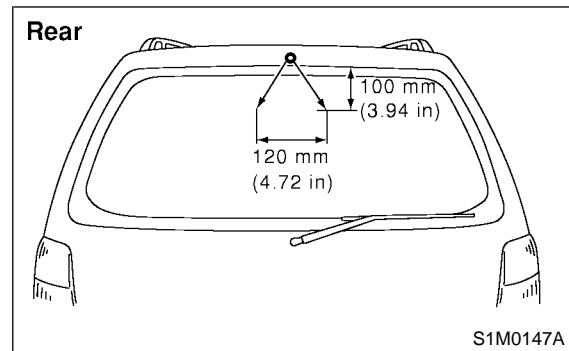
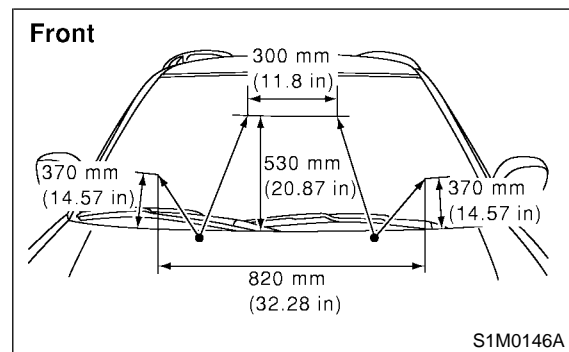

34. WIPER SA09719G5037

Check the front and rear wipers for normal operations.

35. POWER WINDOW OPERATION CHECK SA09719G5004

Manipulate the power window switches one by one to check that each of the power windows goes up and down with no abnormal noises.

36. BRAKE TEST SA09719G5038

Check the foot brake for normal operations.

37. PARKING BRAKE SA09719G5039

Check the parking brake for normal operations.

PRE-DELIVERY INSPECTION

Pre-delivery Inspection

38. AT SHIFT CONTROL SA09719G5041

Set the AT select lever to each gear position while checking that the demanded gear position is correctly attained.

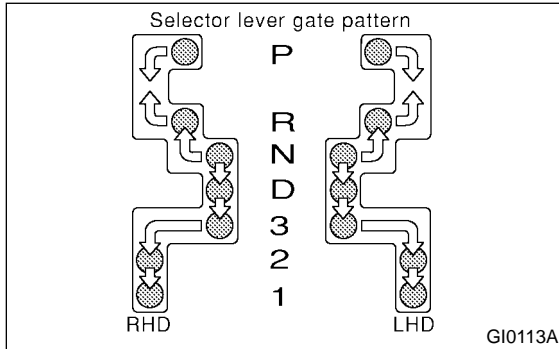

Selector Position	Gear Position			
	1st	2nd	3rd	4th
D	Yes	Yes	Yes	Yes
3	Yes	Yes	Yes	
2	Yes	Yes		
1	Yes			

39. HEATER & VENTILATION SA09719G5042

Operate the heater and ventilation system to check for normal airflow and heating capacity.

40. AIR CONDITIONER SA09719G5043

Operate the air conditioner. Check that the A/C compressor operates normally and enough cooling is provided.

41. CRUISE CONTROL SA09719G5044

Operate the cruise control system. Check that the system is activated and deactivated correctly.

42. ATF LEVEL SA09719G5045

Check that the ATF level is normal. If insufficient, check that no leaks are found. Then add the necessary amount of the specified ATF.

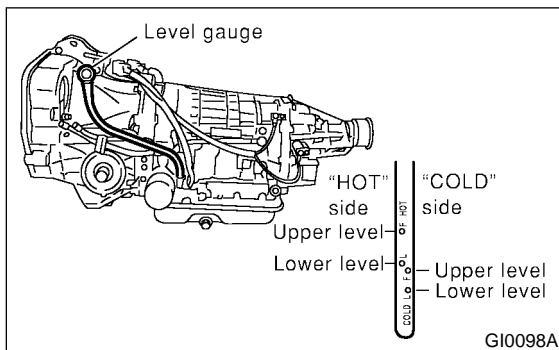

43. POWER STEERING FLUID LEVEL SA09719G5046

- 1) Check power steering fluid for deterioration or contamination. If the fluid is highly deteriorated or contaminated, drain it and refill with new fluid.
- 2) Check joints and units for oil leakage. If any oil leaks are found, repair or replace the applicable part.
- 3) Inspect fluid level on flat and level surface with engine "OFF" by indicator of reservoir tank. If the level is at lower point or below, add fluid to keep the level in the specified range of the indicator. If at upper point or above, drain fluid by using a syringe or the like.

(1) Check at temperature 20°C (68°F) on reservoir surface of oil pump; read the fluid level on the "COLD" side.

(2) Check at temperature 80°C (176°F) on reservoir surface of oil pump; read the fluid level on the "HOT" side.

Non-turbo model

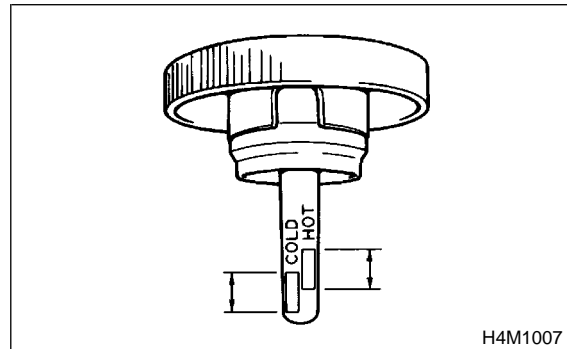

Turbo model

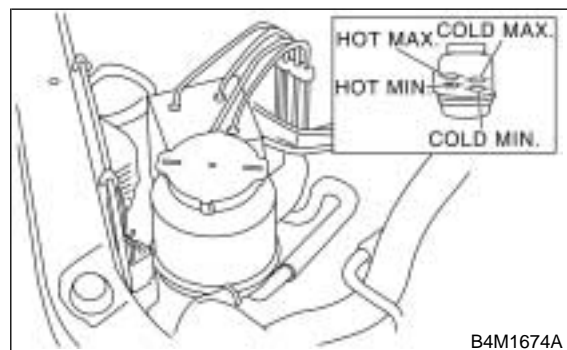

44. FLUID LEAK CHECK SA09719G5047

Check the entire areas of the vehicle for any trace of coolant/oil/fluid leaks.

45. WATER LEAK TEST SA09719G5048

Spray the vehicle with water and check that no water enters the passenger compartment.

- Before performing the water leakage test, remove anything that may obstruct the operation or which must be kept dry.
- Close all of the windows completely, and then close all of the doors tightly. Close the hood and trunk lid before starting the test.
- Connect a hose to a tap, and spray water on the vehicle. The rate of water discharge must be approx. 20 to 25 liters (5.3 to 6.6 US gal, 4.4 to 5.5 Imp gal) per minute.

When spraying water on areas adjacent to the floor and wheel house, increase the pressure. When directing water on areas other than the floor portion and wheel house, decrease the pressure. But the force of water must be made strong occasionally by pressing the end of the hose.

NOTE:

Be sure to keep the hose at least 10 cm (3.9 in) from the vehicle.

- Check the following areas:
 - Front window and body framework mating portion
 - Door mating portions
 - Glass mating portions
 - Rear quarter window mating portions
 - Rear window and body framework mating portion
 - Around roof drips
- If any dampness in the compartments is discovered after the water has been applied, carefully check all areas that may have possibly contributed to the leak.

46. APPEARANCE CHECK 2 SA09719G5049

Check the vehicle body paints, plated faces, glass, and lenses for any dirt or damage.

PRE-DELIVERY INSPECTION

Pre-delivery Inspection

MEMO:

PERIODIC MAINTENANCE SERVICES

PM

	Page
1. General Description.....	2
2. Schedule.....	3
3. Engine Oil.....	6
4. Engine Oil Filter.....	8
5. Spark Plugs.....	9
6. Drive Belt(s).....	10
7. Camshaft Drive Belt.....	12
8. Valve Clearance.....	14
9. Fuel Line.....	15
10. Fuel Filter.....	16
11. Air Cleaner Element.....	17
12. Cooling System.....	18
13. Coolant.....	19
14. Idle Mixture.....	21
15. Clutch System.....	22
16. Hill-holder System.....	24
17. Transmission Oil.....	25
18. ATF.....	26
19. Front & Rear Differential Oil.....	27
20. Brake Line.....	29
21. Brake Fluid.....	31
22. Disc Brake Pads and Discs.....	32
23. Brake Linings and Drums.....	33
24. Suspension.....	35
25. Wheel Bearing.....	37
26. Axle Boots & Joints.....	38
27. Steering System (Power Steering).....	39
28. Supplemental Restraint System.....	42

GENERAL DESCRIPTION

Periodic Maintenance Services

1. General Description SA07001

A: GENERAL SA07001G23

Be sure to perform periodic maintenance in order to maintain vehicle performance and find problems before they become serious.

SCHEDULE

2. Schedule SA07682

A: MAINTENANCE SCHEDULE 1 SA07682G24

1. MAINTENANCE SCHEDULE 1 – (1) SA07682G2401

For periodic maintenance of over 50,000 km (30,000 miles) or 48 months, carry out inspections by referring to the following tables. For a maintenance period gone beyond these tables, apply them repeatedly as a set of 50,000 km (30,000 miles) or 48 months.

		Maintenance Interval [Number of months or km (miles), whichever occurs first]					Remarks
	Months		12	24	36	48	
	× 1,000 km	5	12.5	25	37.5	50	
	× 1,000 miles	3	7.5	15	22.5	30	
1	Engine oil		R	R	R	R	
2	Engine oil filter		R	R	R	R	

2. MAINTENANCE SCHEDULE 1 – (2) SA07682G2402

For periodic maintenance of over 100,000 km (60,000 miles) or 48 months, carry out inspections by referring to the following tables. For a maintenance period gone beyond these tables, apply them repeatedly as a set of 100,000 km (60,000 miles) or 48 months.

		Maintenance Interval [Number of months or km (miles), whichever occurs first]					Remarks
	Months		12	24	36	48	
	× 1,000 km	1.6	25	50	75	100	
	× 1,000 miles	1	15	30	45	60	
3	Spark plugs			R		R	
4	Drive belt(s)		I	I	I	I	
5	Camshaft drive belt					R	
6	Valve clearance	Use in Europe countries					Inspect every 100,000 km (60,000 miles)
		Use in others					Inspect every 160,000 km (100,000 miles)
7	Fuel line			I		I	
8	Fuel filter					R	
9	Air cleaner element		I	R	I	R	
10	Cooling system			I		I	
11	Coolant			R		R	
12	Idle mixture	I	I	I	I	I	For models without catalyst converter
13	Clutch system		I	I	I	I	
14	Hill-holder system	I	I	I	I	I	
15	Transmission oil			R		R	
16	ATF			R		R	
17	Front & rear differential oil			R		R	
18	Brake line			I		I	
19	Brake fluid			R		R	
20	Disc brake pads & discs		I	I	I	I	
21	Brake linings and drums			I		I	
22	Parking brake		I	I	I	I	
23	Suspension		I	I	I	I	

SCHEDULE

Periodic Maintenance Services

			Maintenance Interval [Number of months or km (miles), whichever occurs first]					Remarks
	Months		12	24	36	48		
	× 1,000 km	1.6	25	50	75	100		
	× 1,000 miles	1	15	30	45	60		
24	Wheel bearing							
25	Axle boots & joints							
26	Steering system (Power steering)							

Symbols used:

R: Replace

I: Inspection

(R) or (I): Recommended service for safe vehicle operation.

NOTE:

- (1) When the vehicle is used in extremely dusty conditions, the air cleaner element should be replaced more often.
- (2) ATF filter is maintenance free part. ATF filter needs replacement, when it has physically damaged or ATF leaked.

SCHEDULE

Periodic Maintenance Services

B: MAINTENANCE SCHEDULE 2 SA07682G25

Item	Every	Repeat short distance drive	Repeat rough/muddy road drive	Extremely cold weather area	Salt or other corrosive used or coastal area	High humidity or mountain area	Repeat towing trailer
Engine oil		Replace more frequently		Replace more frequently			Replace more frequently
Engine oil filter		Replace more frequently		Replace more frequently			Replace more frequently
Fuel line	6 months				I		
	12,500 km						
	7,500 miles						
Transmission oil							Replace more frequently
ATF							Replace more frequently
Front & rear differential oil							Replace more frequently
Brake line	6 months	I	I		I		I
	12,500 km						
	7,500 miles						
Brake fluid	12 months					R	
	25,000 km						
	15,000 miles						
Brake pads	6 months	I	I		I		I
	12,500 km						
	7,500 miles						
Brake linings and drums	6 months	I	I		I		I
	12,500 km						
	7,500 miles						
Parking brake	6 months	I	I		I		I
	12,500 km						
	7,500 miles						
Suspension	6 months		I	I	I		I
	12,500 km						
	7,500 miles						
Axle boots & joints	6 months	I	I	I	I		I
	12,500 km						
	7,500 miles						
Steering system (Power steering)	6 months	I	I	I	I		I
	12,500 km						
	7,500 miles						

ENGINE OIL

Periodic Maintenance Services

3. Engine Oil SA07077

A: REPLACEMENT SA07077A20

1) Drain engine oil by loosening engine oil drain plug.

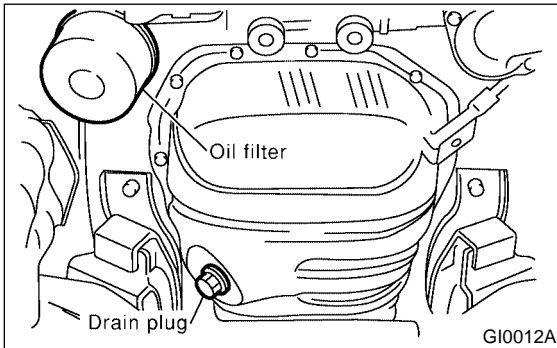

- 2) Open engine oil filler cap for quick draining of the engine oil.
- 3) Replace drain plug gasket.
- 4) Tighten engine oil drain plug after draining engine oil.

Tightening torque:

44 N·m (4.5 kgf·m, 33 ft·lb)

5) Fill engine oil through filler pipe up to upper point on level gauge. Make sure that vehicle is placed level when checking oil level. Use engine oil of proper quality and viscosity, selected in accordance with the table in figure.

Engine oil capacity (Non-TURBO model):

Upper level

4.5 ℓ (4.8 US qt, 4.0 Imp qt)

Lower level

3.5 ℓ (3.7 US qt, 3.1 Imp qt)

Engine oil capacity (TURBO model):

Upper level

5.0 ℓ (5.3 US qt, 4.4 Imp qt)

Lower level

4.0 ℓ (4.2 US qt, 3.5 Imp qt)

NOTE:

● When replenishing oil, it does not matter if the oil to be added is a different brand from that in the engine; however, use oil having the API classification and SAE viscosity No. designated by SUBARU.

● If vehicle is used in desert areas with very high temperatures or for other heavy duty applications, the following viscosity oils may be used:

API classification: SJ or SH

SAE Viscosity No.: 30, 40, 10W-50, 20W-40, 20W-50

6) Close engine oil filler cap.

7) Start engine and warm it up for a time.

8) After engine stops, recheck the oil level.

If necessary, add engine oil up to upper level on level gauge.

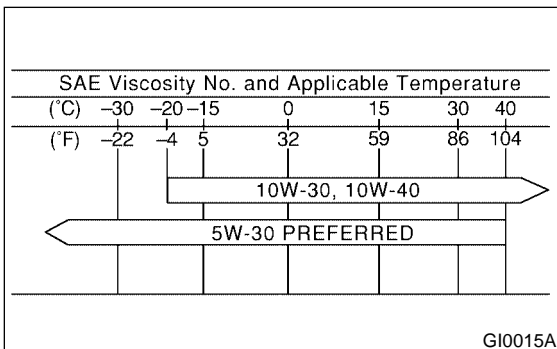
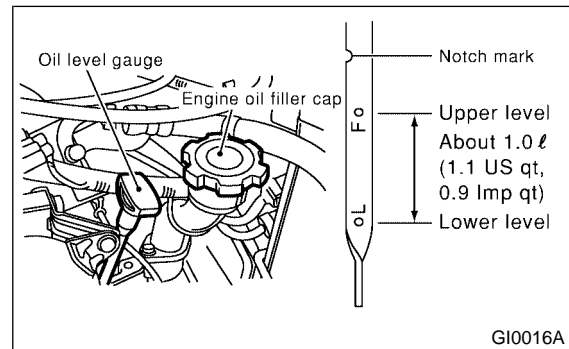

The proper viscosity helps vehicle get good cold and hot starting by reducing viscous friction and thus increasing cranking speed.

B: INSPECTION SA07077A10

- 1) Park vehicle on a level surface.
- 2) Remove oil level gauge and wipe it clean.
- 3) Reinsert the level gauge all the way. Be sure that the level gauge is correctly inserted and in the proper orientation.
- 4) Remove it again and note the reading. If the engine oil level is below the “L” line, add oil to bring the level up to the “F” line.

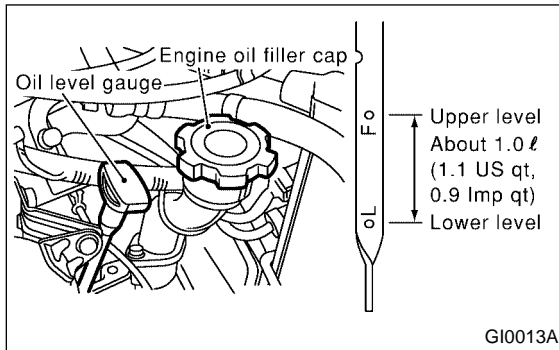

- 5) After turning off the engine, wait a few minutes for the oil to drain back into the oil pan before checking the level.
- 6) Just after driving or while the engine is warm, engine oil level may show in the range between the “F” line and the notch mark. This is caused by thermal expansion of the engine oil.
- 7) To prevent overfilling the engine oil, do not add oil above the “F” line when the engine is cold.

4. Engine Oil Filter SA07585

A: REPLACEMENT SA07585A20

- 1) Remove oil filter with ST.
ST 498547000 OIL FILTER WRENCH

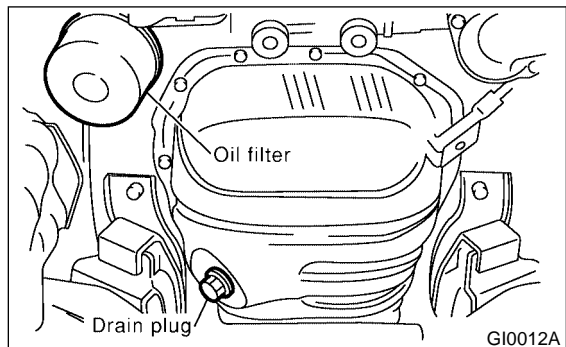

- 2) Get a new oil filter and apply a thin coat of engine oil to the seal rubber.
- 3) Install oil filter by turning it by hand, being careful not to damage seal rubber.
- 4) Tighten more (approximately 2/3 to 3/4 turn) after the seal rubber contacts the oil pump case. Do not tighten excessively, or oil may leak.
- 5) After installing oil filter, run engine and make sure that no oil is leaking around seal rubber.

NOTE:

The filter element and filter case are permanently joined; therefore, interior cleaning is not necessary.

- 6) Check the engine oil level. <Ref. to PI-7, ENGINE OIL, PDI PROCEDURE, Pre-delivery Inspection.>

5. Spark Plugs SA07683

A: REPLACEMENT SA07683A20

1. NON-TURBO MODEL SA07683A2003

NOTE:

For spark plug replacement procedure details, refer to IG section. <Ref. to IG(SOHC)-4, Spark Plug.> and <Ref. to IG(SOHCw/oOBD)-5, Spark Plug.>

- 1) Disconnect battery ground cable.
- 2) Remove air intake duct as a unit.
- 3) Remove resonator chamber.
- 4) Remove washer tank and put it aside.
- 5) Disconnect spark plug cord.
- 6) Remove spark plug with a plug-wrench.

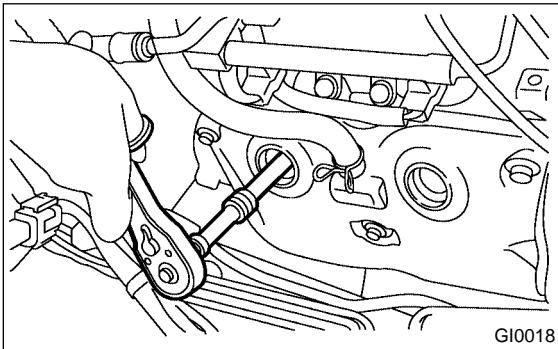

- 7) Set new spark plug.

Recommended spark plug:

With OBD

CHAMPION RC10YC4

CHAMPION RC8YC4

NGK BKR6E-11

NIPPONDENSO K20PR-U11

Spark plug gap

1.0 — 1.1 mm (0.039 — 0.043 in)

Without OBD

NGK BKR6E (Without catalytic converter)

CHAMPION RC10YC4 (With catalytic converter)

NGK BKR5E-11 (With catalytic converter)

Spark plug gap

0.7— 0.8 mm (0.028 — 0.031 in) (Without catalytic converter)

1.0 — 1.1 mm (0.039 — 0.043 in) (With catalytic converter)

- 8) Tighten spark plug lightly with hand, and then secure with a plug-wrench to the specified torque.

Tightening torque:

20.6 N-m (2.10 kgf-m, 15.19 ft-lb)

NOTE:

- Be sure to place the gasket between the cylinder head and spark plug.
- If torque wrench is not available, tighten spark plug until gasket contacts cylinder head; then

tighten further 1/4 to 1/2 turns.

2. TURBO MODEL SA07683A2004

NOTE:

For spark plug replacement procedure details, refer to IG section. <Ref. to IG(DOHC TURBO)-4, Spark Plug.>

- 1) Disconnect battery ground cable, and then remove battery and battery carrier.
- 2) Remove air cleaner lower case. <Ref. to IN(DOHC TURBO)-7, Air Cleaner.>
- 3) Remove washer tank and put it aside.
- 4) Disconnect connector from ignition coil.
- 5) Remove ignition coil.
- 6) Remove spark plug with a plug-wrench.

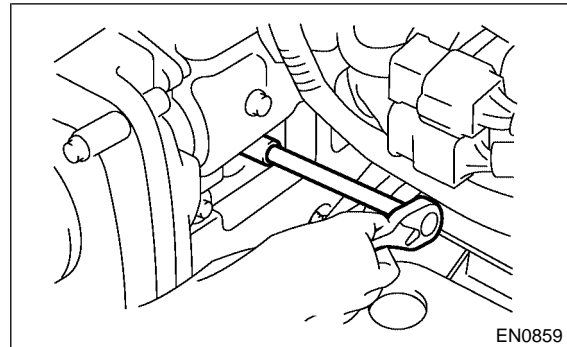

- 7) Set new spark plug.

Recommended spark plug:

NGK: PFR6B

- 8) Tighten spark plug lightly with hand, and then secure with a plug-wrench to the specified torque.

Tightening torque:

Spark plug

21 N-m (2.1 kgf-m, 15 ft-lb)

Ignition coil

16 N-m (1.63 kgf-m, 11.8 ft-lb)

NOTE:

- Be sure to place the gasket between the cylinder head and spark plug.
- If torque wrench is not available, tighten spark plug until gasket contacts cylinder head; then tighten further 1/4 to 1/2 turns.

DRIVE BELT(S)

Periodic Maintenance Services

6. Drive Belt(s) SA07684

A: INSPECTION SA07684A10

- 1) Replace belts, if cracks, fraying or wear is found.
- 2) Check drive belt tension and adjust it if necessary by changing generator installing position and/or idler pulley installing position.

Belt tension

(A)

replaced: 7 — 9 mm (0.276 — 0.354 in)

reused: 9.0 — 10.0 mm (0.354 — 0.394 in)

(B)*

replaced: 7.5 — 8.5 mm (0.295 — 0.335 in)

reused: 9.0 — 10.0 mm (0.354 — 0.394 in)

*: There is no belt (B) on models without an air conditioner.

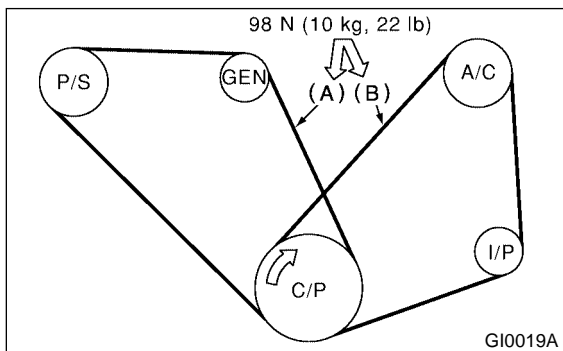

C/P Crankshaft pulley

GEN Generator

P/S Power steering oil pump pulley

A/C Air conditioning compressor pulley

I/P Idler pulley

B: REPLACEMENT SA07684A20

NOTE:

Wipe off any oil or water on the belt and pulley.

- 1) Loosen the lock bolt (A).
- 2) Loosen the slider bolt (B).
- 3) Remove the front side belt (C).

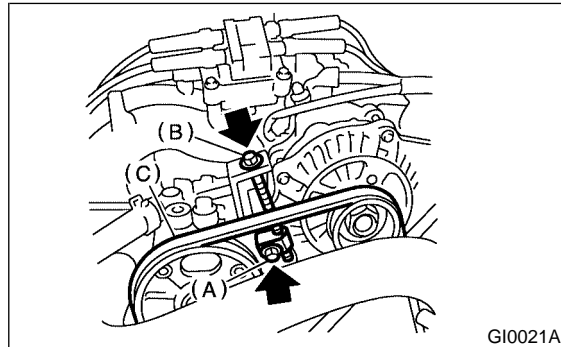

- 4) Loosen the lock nut (A).
- 5) Loosen the slider bolt (B).
- 6) Remove the rear side belt.

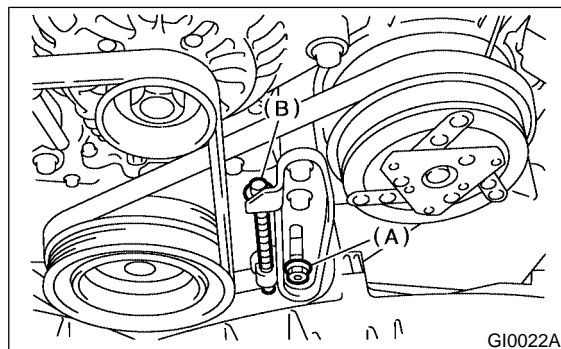

- 7) Install a new belt, and tighten the slider bolt so as to obtain the specified belt tension.
- 8) Tighten the slider bolt (B).
- 9) Tighten the lock nut (A).

Tightening torque:

22.6 N-m (2.3 kgf-m, 16.6 ft-lb)

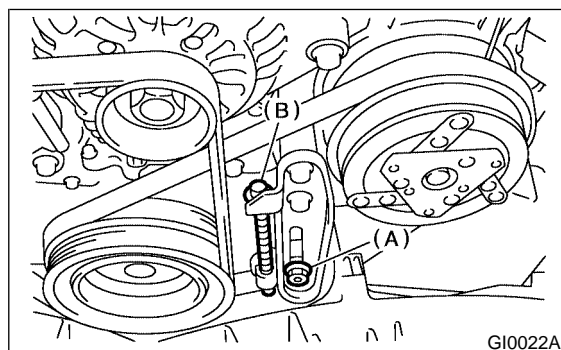

- 10) Install a new belt, and tighten the slider bolt so as to obtain the specified belt tension.
- 11) Tighten the slider bolt (B).
- 12) Tighten the lock bolt (A).

Tightening torque:

Lock bolt, through bolt:

25 N·m (2.5 kgf·m, 18 ft·lb)

Slider bolt:

8 N·m (0.8 kgf·m, 5.8 ft·lb)

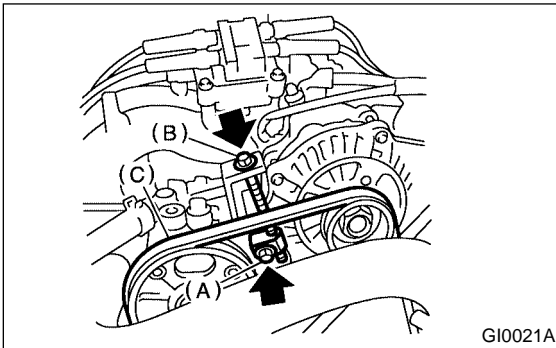

GI0021A

CAMSHAFT DRIVE BELT

Periodic Maintenance Services

7. Camshaft Drive Belt

SA07685

A: REPLACEMENT

SA07685A20

1. SOHC MODEL

SA07685A2001

NOTE:

For camshaft drive belt replacement procedure details, refer to ME(SOHC) section. <Ref. to ME(SOHC)-46, Timing Belt Assembly.>

1) Remove radiator fan <Ref. to CO-32, Radiator Main Fan and Fan Motor.> and air conditioner fan <Ref. to CO-34, Radiator Sub Fan and Fan Motor.>

2) Remove V-belt cover.

3) Remove V-belts. <Ref. to ME(SOHC)-42, V-belt.>

4) Remove air conditioning compressor drive belt tensioner.

5) Remove pulley bolt.

ST 499977100 CRANKSHAFT PULLEY
WRENCH

6) Remove crankshaft pulley.

7) Remove left side belt cover.

8) Remove front belt cover.

9) Remove timing belt guide. (MT vehicle only)

10) Turn crankshaft and align alignment marks on crankshaft, and left and right camshaft sprockets with notches of belt cover and cylinder block:

ST 499987500 CRANKSHAFT SOCKET

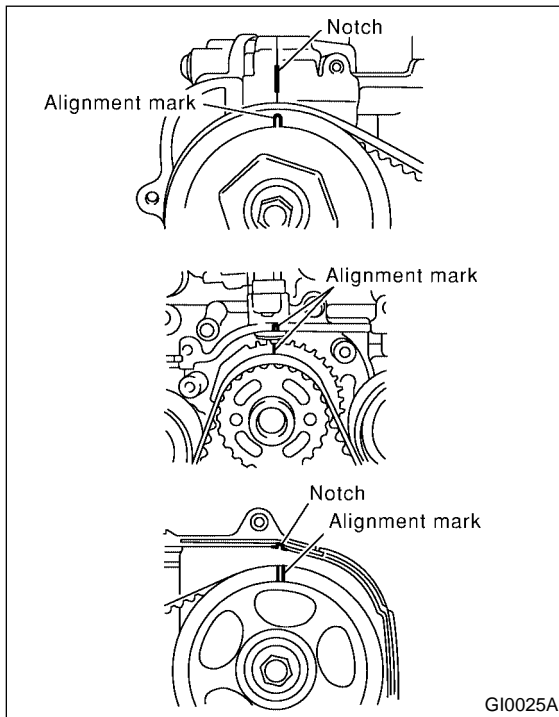

11) Remove belt idler.

12) Remove belt idler (No. 2).

13) Remove timing belt.

14) Remove automatic belt tension adjuster assembly.

2. DOHC MODEL

SA07685A2002

NOTE:

For camshaft drive belt replacement procedure details, refer to ME(DOHC) section. <Ref. to ME(SOHC)-46, Timing Belt Assembly.>

1) Remove radiator fan and air conditioning fan. <Ref. to CO-32, Radiator Main Fan and Fan Motor.> and <Ref. to CO-34, Radiator Sub Fan and Fan Motor.>

2) Remove V-belts. <Ref. to ME(DOHC TURBO)-44, V-belt.>

3) Remove air conditioning compressor drive belt tensioner.

4) Remove pulley bolt.

ST 499977300 CRANKSHAFT PULLEY
WRENCH

5) Remove crankshaft pulley.

6) Remove air conditioning compressor drive belt tensioner.

7) Remove left side belt cover.

8) Remove right side belt cover.

9) Remove front belt cover.

10) Remove timing belt guide. (MT vehicle only)

11) Turn crankshaft and align alignment marks on crankshaft, and left and right camshaft sprockets with notches of belt cover and cylinder block. To turn crankshaft, Use ST:

ST 499987500 CRANKSHAFT SOCKET

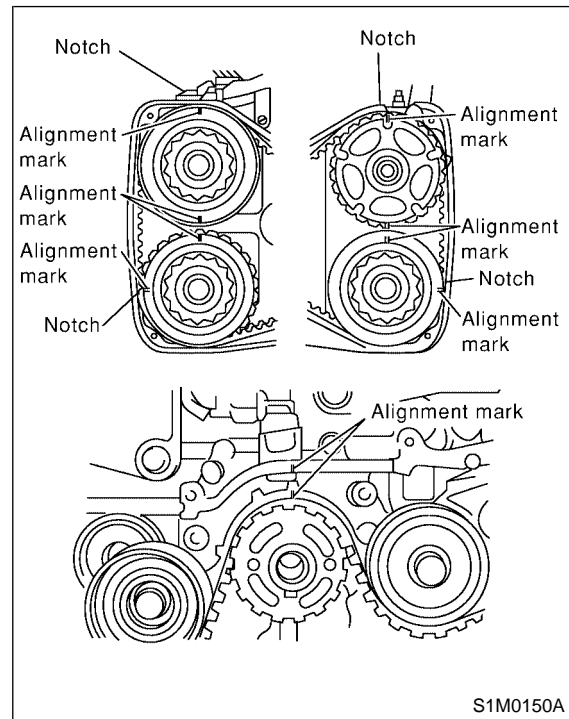

12) Remove belt idler.

13) Remove timing belt.

14) Remove automatic belt tension adjuster assembly.

B: INSTALLATION SA07685A11**1. SOHC MODEL** SA07685A1101

Install in the reverse order of removal. <Ref. to ME(SOHC)-46, Timing Belt Assembly.>

2. DOHC MODEL SA07685A1102

Install in the reverse order of removal. <Ref. to ME(DOHC TURBO)-48, Timing Belt Assembly.>

NOTE:

When installing the timing belt, be sure to align all alignment marks on the belt with corresponding marks on the sprockets. If incorrectly installed, interference between pistons and valves may occur.

C: INSPECTION SA07685A10**1. SOHC MODEL** SA07685A1001

- 1) Remove left and right timing belt covers.
- 2) While cranking engine at least four rotations, check timing belt back surface for cracks or damage. Replace faulty timing belt as needed.
- 3) Measure timing belt width W. If it is less than 27 mm (1.06 in), check idlers, tensioner, water pump pulley and cam sprocket to determine idler alignment (squareness). Replace worn timing belt.

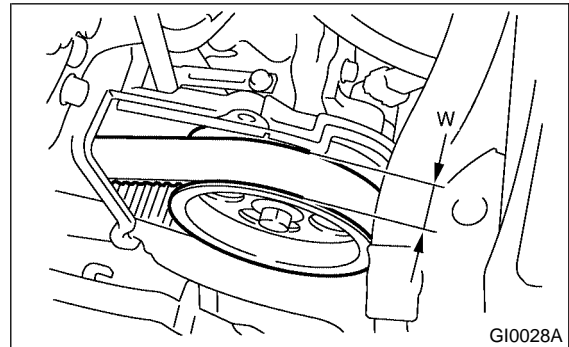

- 4) Install left and right timing belt covers.

2. DOHC MODEL SA07685A1002

- 1) Remove left and right timing belt covers.
- 2) While cranking engine at least four rotations, check timing belt back surface for cracks or damage. Replace faulty timing belt as needed.
- 3) Measure timing belt width W. If it is less than 30 mm (1.18 in), check idlers, tensioner, water pump pulley and cam sprocket to determine idler alignment (squareness). Replace worn timing belt.
- 4) Install left and right timing belt covers.

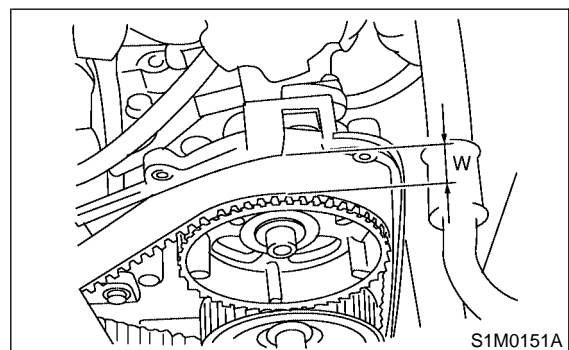

8. Valve Clearance SA07083

A: INSPECTION SA07083A10

For the inspection procedures of the valve clearance: <Ref. to ME(SOHC)-29, Valve Clearance.> or <Ref. to ME(DOHC TURBO)-28, Valve Clearance.>

9. Fuel Line SA07686

A: INSPECTION SA07686A10

The fuel line is located mostly internally, so check pipes, areas near pipes, and engine compartment piping for rust, hose damage, loose bands, etc. If faulty parts are found, repair or replace them. <Ref. to FU(SOHC)-69, Fuel Delivery, Return and Evaporation Lines.> or <Ref. to FU(SOHCw/oOBD)-56, Fuel Delivery, Return and Evaporation Lines.> or <Ref. to FU(DOHC TURBO)-67, Fuel Delivery, Return and Evaporation Lines.>

10. Fuel Filter SA07027

A: REPLACEMENT SA07027A20

For fuel filter replacement procedures, refer to “FU” section.

<Ref. to FU(SOHC)-66, Fuel Filter.> or <Ref. to FU(SOHCw/oOBD)-54 Fuel Filter.> or <Ref. to FU(DOHC TURBO)-64, Fuel Filter.>

11. Air Cleaner Element SA07687

A: REPLACEMENT SA07687A20

NOTE:

Do not attempt to clean the air cleaner element. The filter paper of the element is wetted with a special inflammable slow-evaporating viscous liquid. It is resistant to cold weather and has a long service life. Dirt adhering to this filter paper forms porous laminations with the viscous liquid, which function as a filtration layer to reduce dust penetration into the filter paper. If this filter paper is cleaned, the filtration layer thus formed will be lost along with the viscous liquid.

1. NON-TURBO MODEL SA07687A2001

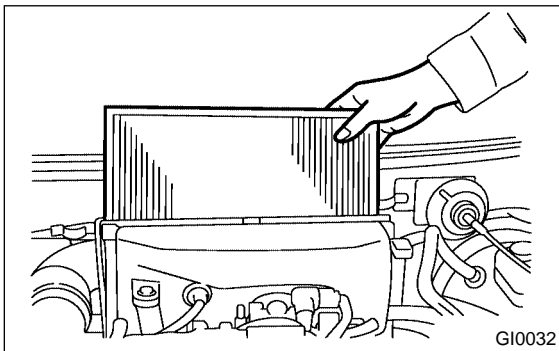

- 1) Remove bolt (A) which install air cleaner case to stays.
- 2) Remove the clip (B) above the air cleaner case.

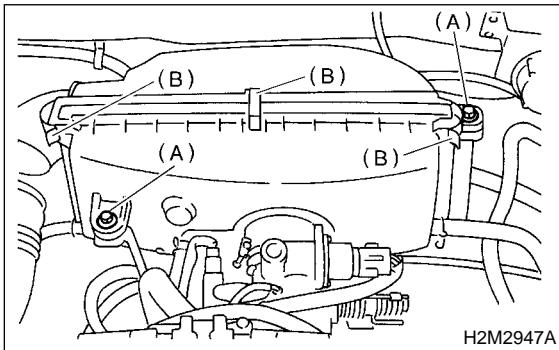

- 3) Remove air cleaner.
- 4) Install in the reverse order of removal.

CAUTION:

Fasten with a clip after inserting the lower tab of the case.

2. TURBO MODEL SA07687A2002

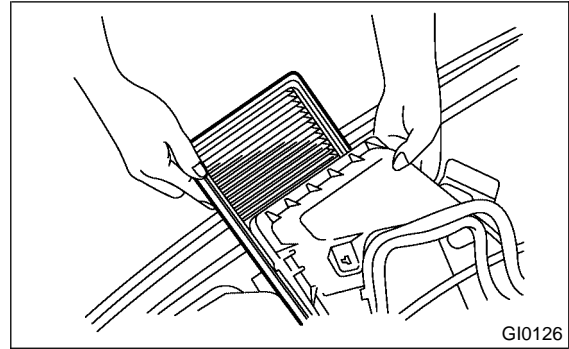

- 1) Remove the clip (B) above the air cleaner case.

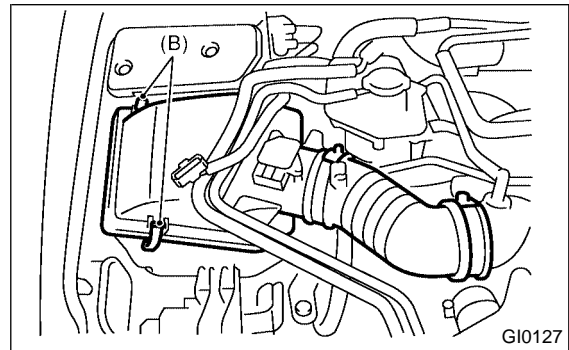

- 2) Remove air cleaner.
- 3) Install in the reverse order of removal.

CAUTION:

Before installing air cleaner upper cover, align holes with protruding portion of air cleaner lower case, then secure upper cover to lower case.

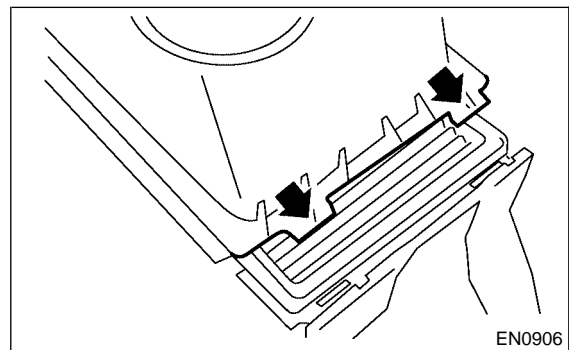

12. Cooling System SA07688

A: INSPECTION SA07688A10

1) Check radiator for leakage, filling it with coolant and attach radiator cap tester (A) to the filler neck. Then apply a pressure of 157 kPa (1.6 kg/cm², 23 psi) and check the following points:

- Each portion of radiator for leakage
- Hose joints and other connections for leakage

CAUTION:

● When attaching or detaching tester and when operating tester, use special care not to deform radiator filler neck.

Non-TURBO model

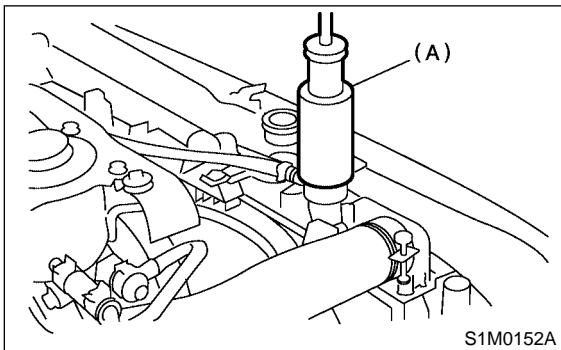

TURBO model

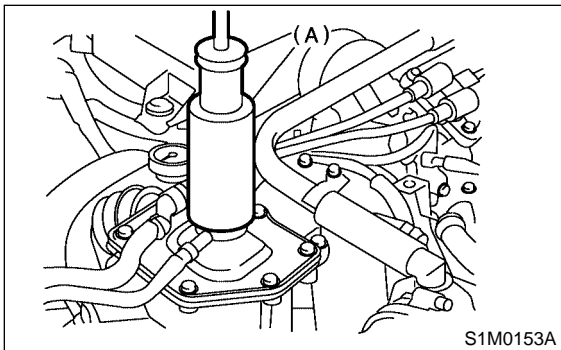

● When performing this check, be sure to keep the engine stationary and fill radiator with coolant.

- Wipe off check points before applying pressure.
- Use care not to spill coolant when detaching tester from radiator.

2) Check the radiator cap valve open pressure using radiator cap tester.

NOTE:

Rust or dirt on cap may prevent valve from functioning normally: be sure to clean cap before testing.

Raise the pressure until the needle of gauge stops and see if the pressure can be retained for five to six seconds. The radiator cap is normal if a pressure above the service limit value has been maintained for this period.

Radiator cap valve open pressure

Standard value:

93 — 123 kPa (0.95 — 1.25 kg/cm², 14 — 18 psi)

Service limit:

83 kPa (0.85 kg/cm², 12 psi)

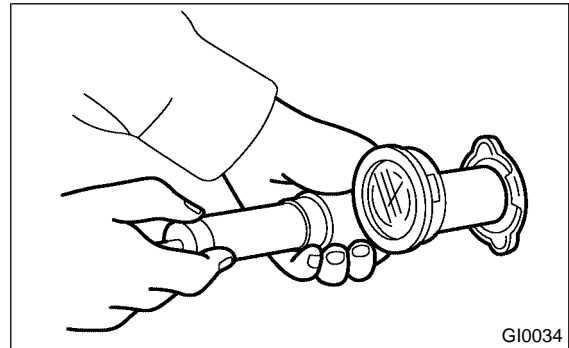

GI0034

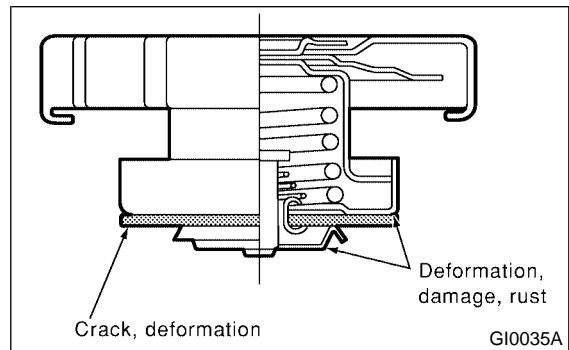

GI0035A

3) If the coolant temperature exceeds 76.0 to 80.0°C (169 to 176°F) while radiator is not so hot, check thermostat. If thermostat does not open at 76.0 to 80.0°C (169 to 176°F), replace it with a new one.

4) If electric fan does not operate when coolant temperature exceeds 90 to 94°C (194 to 201°F), check thermostwitch or fan motor.

13. Coolant SA07689

A: REPLACEMENT SA07689A20

1. REPLACEMENT OF COOLANT SA07689A2001

WARNING:

The radiator is of the pressurized type. Do not attempt to open the radiator cap immediately after the engine has been stopped.

- 1) Lift up the vehicle.
- 2) Remove under cover.
- 3) Fit vinyl tube to drain pipe.
- 4) Place a container under drain tube.
- 5) Loosen drain cock to drain engine coolant into container.

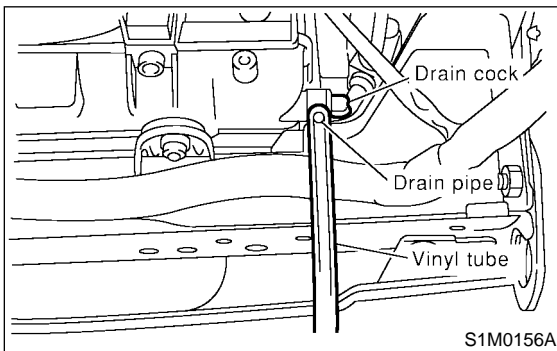

- 6) For quick draining, open radiator cap.

CAUTION:

Be careful not to spill coolant on the floor.

- 7) Drain coolant from reservoir tank.
- 8) Tighten radiator drain screw securely after draining coolant.
- 9) Install reservoir tank to original position.
- 10) Non-TURBO model.
 - (1) Slowly pour prepared coolant from radiator filler port to neck of filler, then pour into reservoir tank up to "FULL" level.

Coolant capacity (fill up to "FULL" level)

MT model:

Approx. 6.4 ℓ (6.8 US qt, 5.6 Imp qt)

AT model:

Approx. 6.3 ℓ (6.7 US qt, 5.5 Imp qt)

NOTE:

The SUBARU Genuine Coolant containing anti-freeze and anti-rust agents is especially made for SUBARU engine, which has an aluminum crank-case. Always use SUBARU Genuine Coolant, since other coolant may cause corrosion.

- (2) Securely install radiator cap.
- (3) Run engine for more than five minutes at 2,000 to 3,000 rpm. (Run engine until radiator becomes hot in order to purge air trapped in cooling system.)

- (4) Stop engine and wait until coolant temperature lowers. Then open radiator cap to check coolant level and add coolant up to radiator filler neck. Next, add coolant into reservoir tank up to "FULL" level.

- (5) After adding coolant, securely install radiator and reservoir tank caps.

11) TURBO model.

- (1) Slowly pour prepared coolant from coolant flow tank filler port up to the brim of port, and install cap, then pour coolant into reserve tank up to "FULL" level.

- (2) Run engine for about 15 minutes, not exceeding 2,000 rpm. (Run engine until radiator becomes hot in order to purge air trapped in cooling system.)

- (3) Stop engine and wait until coolant temperature lowers. [below 50°C (122°F) or 60°C (140°F)] Open coolant flow tank cap and add coolant up to the brim of the port.

- (4) Wait until coolant temperature lowers further [below 30°C (86°F)], then pour into reserve tank up to the "FULL" level.

- (5) Run the vehicle until the coolant temperature rises to 80°C (176°F) and check the level in the coolant flow tank, add coolant up to the "FULL" level.

Coolant capacity (fill up to "FULL" level)

MT model

Approx. 6.4ℓ (6.8 US qt, 5.6 Imp qt)

AT model

Approx. 6.3ℓ (6.7 US qt, 5.5 Imp qt)

COOLANT

2. RELATIONSHIP OF SUBARU COOLANT CONCENTRATION AND FREEZING TEMPERATURE

SA07689A2002

The concentration and safe operating temperature of the SUBARU coolant is shown in the diagram. Measuring the temperature and specific gravity of the coolant will provide this information.

[Example]

If the coolant temperature is 25°C (77°F) and its specific gravity is 1.054, the concentration is 35% (point A), the safe operating temperature is -14°C (7°F) (point B), and the freezing temperature is -20°C (-4°F) (point C).

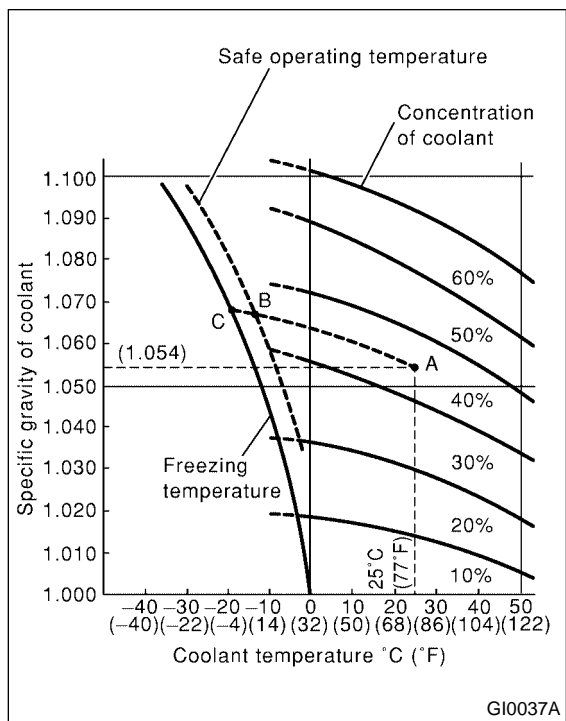

3. PROCEDURE TO ADJUST THE CONCENTRATION OF THE COOLANT

SA07689A2003

To adjust the concentration of the coolant according to temperature, find the proper fluid concentration in the above diagram and replace the necessary amount of coolant with an undiluted solution of SUBARU genuine coolant (concentration 50).

The amount of coolant that should be replaced can be determined using the diagram.

[Example]

Assume that the coolant concentration must be increased from 25% to 40%. Find point A, where the 25% line of coolant concentration intersects with the 40% curve of the necessary coolant concentration, and read the scale on the vertical axis of the graph at height A. The quantity of coolant to be drained is 2.1 liters (2.2 US qt, 1.8 Imp qt). Drain 2.1 liters (2.2 US qt, 1.8 Imp qt) of coolant from the cooling system and add 2.1 liters (2.2 US qt, 1.8 Imp qt) of the undiluted solution of SUBARU coolant.

If a coolant concentration of 50% is needed, drain all the coolant and refill with the undiluted solution only.

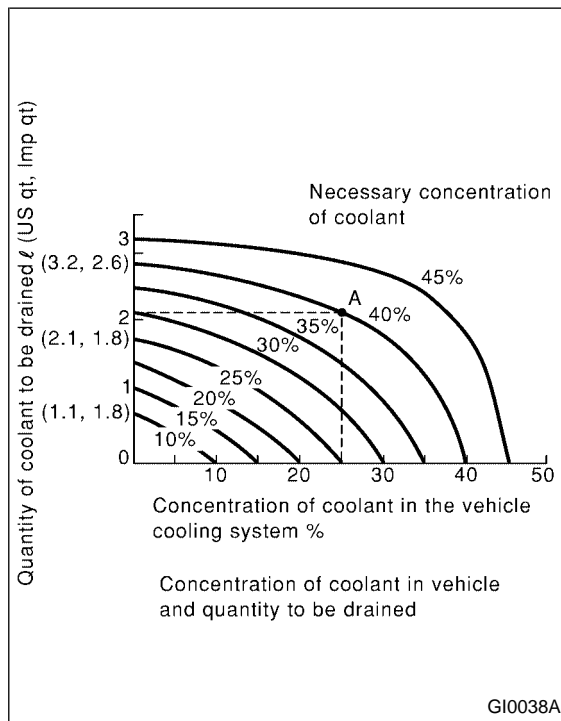

14. Idle Mixture SA07734

A: INSPECTION AND ADJUSTMENT

SA07734G26

1. IDLE MIXTURE SA07734G2601

Before measuring the idle mixture, make sure that the ignition timing and the engine idle speed are within specifications.

- 1) Set the gear position at "Neutral" for MT, or "N" or "P" for AT.
- 2) Warm up engine sufficiently until cooling fan starts to operate.
- 3) Measure the idle mixture with the CO meter.

Engine idle speed	CO
700±100 rpm	1.0±0.5%

- 4) If out of specification, adjust the idle mixture using CO adjusting screw of mass air flow sensor.
- 5) After adjusting the CO value, check and adjust increment coefficient of CO resistor by using Select Monitor.

- (1) Select "Current data display & Save" on the select monitor.
- (2) If out of specified data, adjust the increment coefficient of CO resistor while rotating CO adjusting screw.

Specified data:
0.28 — 4.22 V

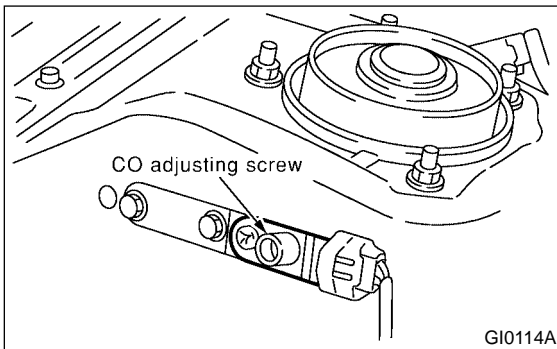

NOTE:
If driving the vehicle on out of specified data, the "trouble code 49" is indicated in many case.

CLUTCH SYSTEM

Periodic Maintenance Services

15. Clutch System SA07690

A: INSPECTION AND ADJUSTMENT

SA07690G26

1. MECHANICAL CLUTCH TYPE SA07690G2601

1) Inspect free play of clutch pedal by operating pedal by hand.

If it is out of the specified value, adjust it by turning wing nut on engine side of clutch cable at release fork.

Tightening torque

(Adjusting nut on release fork):

4.4 — 7.4 N·m (0.45 — 0.75 kgf·m, 3.3 — 5.4 ft·lb)

Standard free play:

AT clutch pedal

10 — 20 mm (0.39 — 0.79 in)

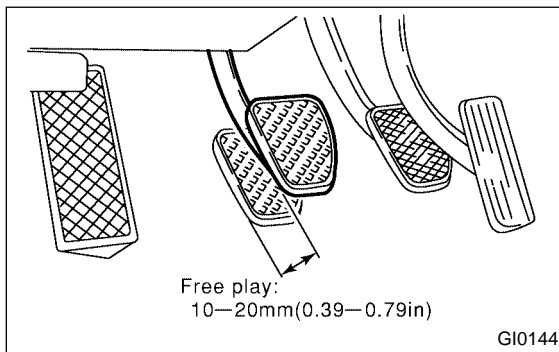

Fork lever free play allowance:

2 — 4 mm (0.08 — 0.16 in)

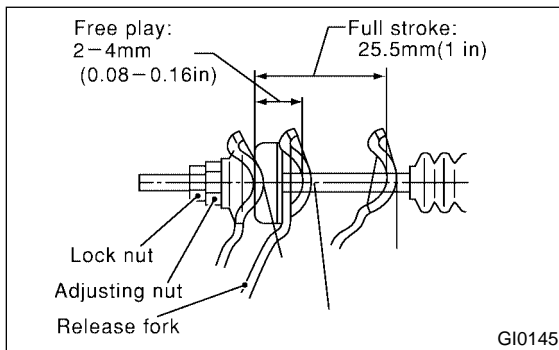

- 2) Pedal-to-floor plate gap in disengaged position.
- (1) With the engine idling, pull parking brake lever completely.
 - (2) Slowly depress clutch pedal while moving shift lever into reverse.
 - (3) Stop depressing clutch pedal when gear-shifting is complete. With clutch pedal in this position, measure the distance between the upper side of pedal pad and the lower end of front panel (intersection of front panel with floor). Check that the measured value is within the specified standard.

Standard:

80 mm (3.15 in) or more

3) Pedal height

Check that the clutch pedal pad surface is level with or higher than brake pedal pad surface.

2. HYDRAULIC CLUTCH TYPE SA07690G2602

1) Push the release lever to retract the push rod of the operating cylinder and check if the fluid level in the clutch reservoir tank rises or not.

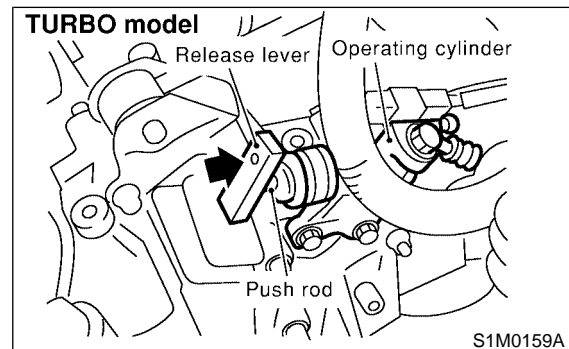
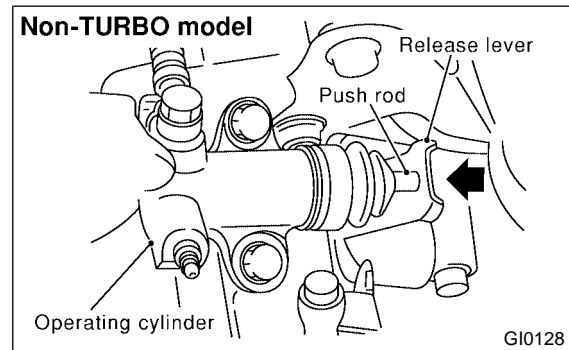

- 2) If the fluid level rises, pedal free play is correct.
- 3) If the fluid level does not rise, or the push rod cannot be retracted, adjust the clutch pedal. <Ref. to CL-37 Clutch Pedal.>
- 4) Inspect the underside of master cylinder, clutch damper and operating cylinder for clutch system, hoses, piping and their couplings for fluid leaks. If fluid leaks are found, correct them by retightening their fitting bolt and/or replacing their parts.
- 5) Check the fluid level using the scale on the outside of the clutch master cylinder tank (A). If the level is below "MIN" (B), add clutch fluid to bring it up to "MAX" (C).

Recommended clutch fluid:

FMVSS No. 116, fresh DOT3 or DOT4 brake fluid

NOTE:

- Avoid mixing different grades of brake fluid to prevent degradation of the fluid.
- Be careful not to allow dirt or dust to get into the reservoir tank.

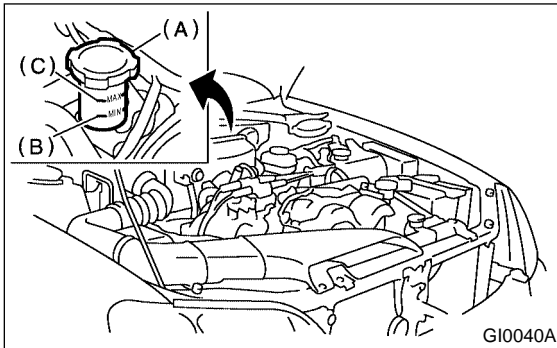

16. Hill-holder System SA07735

A: INSPECTION AND ADJUSTMENT

SA07735G26

1) Confirm stopping and starting performance by activating hill-holder on an uphill road of 3° or higher inclination.

(1) When vehicle does not stop;
Tighten adjusting nut of PHV cable.

(2) When vehicle does not start properly;
A; When hill-holder is released later than engagement of clutch (engine tends to stall):
Loosen adjusting nut gradually until smooth starting is enabled.

B; When hill-holder is released earlier than engagement to clutch (vehicle slips down slightly): Tighten adjusting nut so that hill-holder is released later than engagement of clutch (status in A). Then make adjustment the same as in A.

NOTE:

- Whenever turning adjusting nut, hold inner cable with pliers to prevent it from turning.
- Replace pressure hold valve (PHV), return spring of PHV or PHV cable with new one, if they are defective and/or damaged.

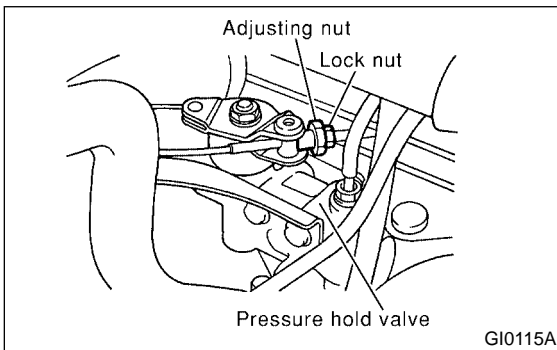

17. Transmission Oil SA07691

A: REPLACEMENT SA07691A20

1. MANUAL TRANSMISSION SA07691A2001

1) Drain gear oil by removing drain plug after allowing the engine to cool for 3 to 4 hours.

NOTE:

Before starting work, cool off the engine well.

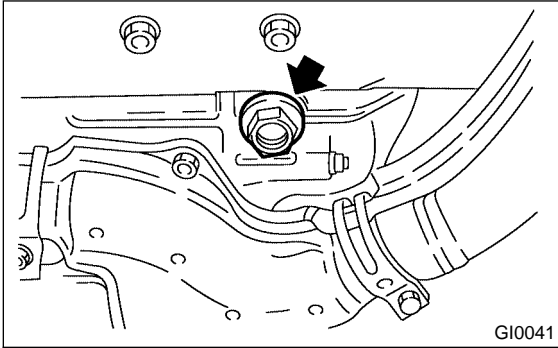

2) Reinstall drain plug after draining gear oil and tighten it to the specified torque.

Tightening torque:

44 N·m (4.5 kgf-m, 32.5 ft-lb)

NOTE:

- Be sure to place a gasket between the transmission case and drain plug.
- Replace the gasket with a new one.
- Each oil manufacturer has its base oil and additives. Thus, do not mix two or more brands.

3) Fill transmission gear oil through the oil level gauge hole up to the upper point of level gauge.

Gear oil capacity:

Single range model

3.5 l (3.7 US qt, 3.1 Imp qt)

Dual range model

4.0 l (4.2 US qt, 3.5 Imp qt)

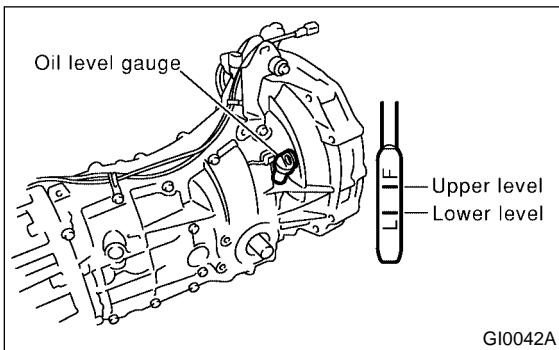

18. ATF SA07692

A: REPLACEMENT SA07692A20

1. AUTOMATIC TRANSMISSION FLUID SA07692A2001

1) Drain ATF (Automatic Transmission Fluid) by removing drain plug after allowing the engine to cool for 3 to 4 hours.

NOTE:

Before starting work, cool off the engine well.

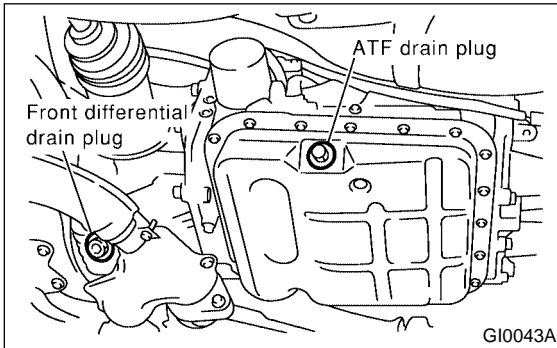

2) Reinstall drain plug after draining ATF, and tighten it to the specified torque.

Tightening torque:

25.0 N·m (2.55 kgf·m, 18.4 ft·lb)

3) Fill ATF up to the middle of the "COLD" side on level gauge by using the gauge hole.

Recommended fluid:

Dexron III type automatic transmission fluid

Fluid capacity:

Fill the same amount drained from ATF drain plug hole.

4) Run the vehicle until the ATF temperature rises to 60 to 80°C (140 to 176°F) and check the ATF level.

2. ATF FILTER SA07692A2002

NOTE:

ATF filter is maintenance free part. ATF filter needs replacement, when it has physically damaged or ATF leaked.

For the replacement procedures of the ATF filter:
<Ref. to AT-46, ATF Filter.>

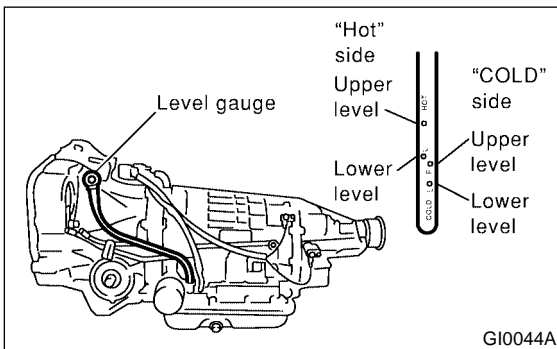

19. Front & Rear Differential Oil

SA07693

A: REPLACEMENT

SA07693A20

1. FRONT DIFFERENTIAL (MANUAL TRANSMISSION)

SA07693A2001

For M/T vehicle, manual transmission oil works as differential oil to lubricate differential. Refer to "Transmission Oil". <Ref. to PM-25 MANUAL TRANSMISSION, REPLACEMENT, Transmission Oil.>

2. FRONT DIFFERENTIAL (AUTOMATIC TRANSMISSION)

SA07693A2002

1) Drain differential gear oil by removing drain plug after allowing the engine to cool for 3 to 4 hours.

NOTE:

Before starting work, cool off the engine well.

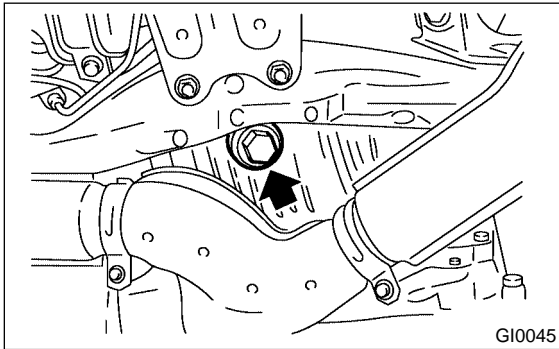

2) Reinstall drain plug after draining differential gear oil and tighten it to the specified torque.

Tightening torque:

44 N·m (4.5 kgf·m, 32.5 ft·lb)

NOTE:

- Be sure to place a gasket between the transmission case and drain plug.
- Replace the gasket with a new one.
- Each oil manufacturer has its base oil and additives. Thus, do not mix two or more brands.

3) Fill differential gear oil through the oil level gauge hole up to the upper point of level gauge.

Differential gear oil capacity:

1.1 — 1.3 ℓ (1.2 — 1.4 US qt, 1.0 — 1.1 Imp qt)

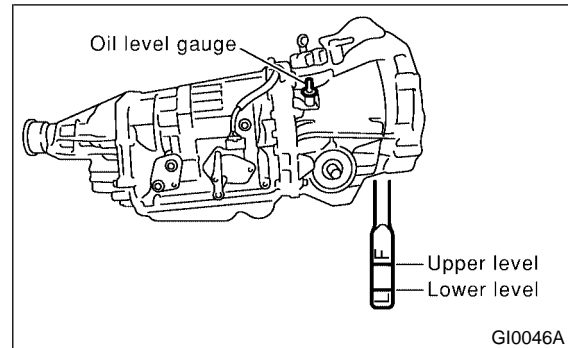

3. REAR DIFFERENTIAL

SA07693A2003

- 1) Drain oil by removing drain plug.
- 2) Remove filler plug for quick draining oil.
- 3) Reinstall drain plug after draining oil.

NOTE:

- Apply fluid packing to drain plug threads before installation in T-type.
- VA-type uses a new aluminum gasket.

Fluid packing:

Three Bond 1105

Tightening torque:

T-type:

49.0 N·m (5.0 kgf·m, 36.2 ft·lb)

VA-type:

34 N·m (3.5 kgf·m, 25.3 ft·lb)

4) After installing drain plug onto rear differential gear case firmly, fill oil up fully to the mouth of filler plug.

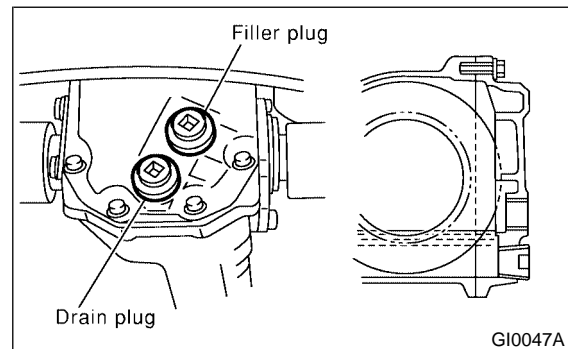

Oil capacity:

0.8 ℓ (0.8 US qt, 0.7 Imp qt)

NOTE:

Each oil manufacturer has its base oil and additives. Thus, do not mix two or more brands.

FRONT & REAR DIFFERENTIAL OIL

Periodic Maintenance Services

5) Install filler plug onto rear differential gear case firmly.

NOTE:

- Apply fluid packing to filler plug before installation in T-type.
- VA-type uses a new aluminum gasket.

Fluid packing:

Three Bond 1105

Tightening torque:

T-type:

49.0 N·m (5.0 kgf-m, 36.2 ft-lb)

VA-type:

34 N·m (3.5 kgf-m, 25.3 ft-lb)

20. Brake Line SA07694

A: INSPECTION SA07694A10

1. BRAKE LINE SA07694A1001

- 1) Check scratches, swelling, corrosion and/or traces of fluid leakage on brake hoses or pipe joints.
- 2) Check the possibility of adjacent parts interfering with brake pipes/hoses during driving, and loose connections/clamps.
- 3) Check any trace of fluid leakage, scratches, etc. on master cylinder, wheel cylinder and pressure control valve.

NOTE:

- When the brake fluid level in the reservoir tank is lower than the specified limit, the brake fluid warning light on the combination meter will come on.
- Visually check brake hose (using a mirror where it is difficult to see) for any damage.

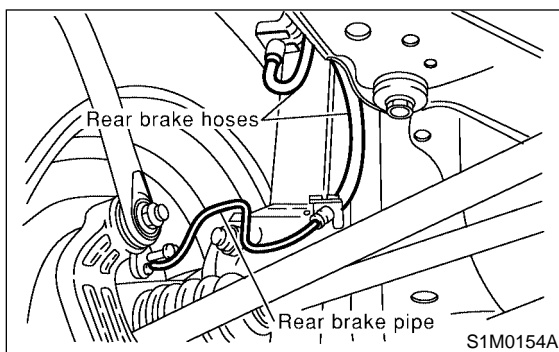
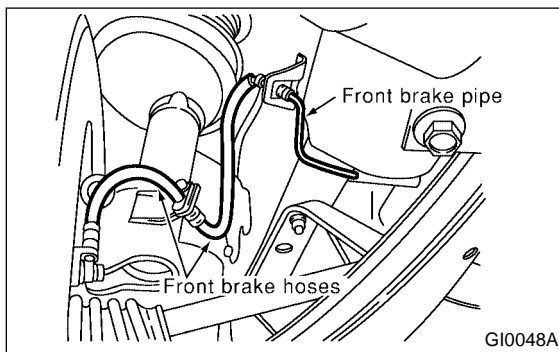

B: CHECKING SA07694G27

1. SERVICE BRAKE SA07694G2701

- 1) Check the free play of brake pedal with a force of less than 10 N (1 kgf, 2 lb).

Brake pedal free play:
1 — 3 mm (0.04 — 0.12 in)

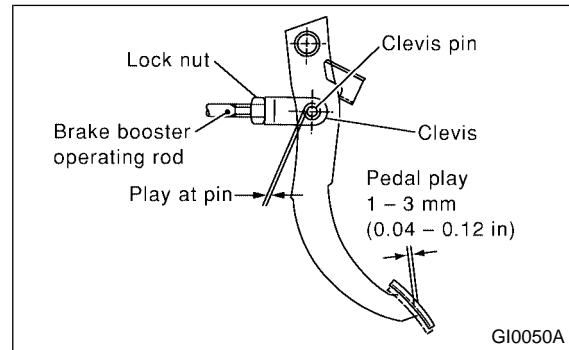

- 2) If the free play is out of specifications above, adjust the brake pedal as follows:

- (1) Be sure engine is off. (No vacuum is applied to brake booster.)
- (2) There should be play between brake booster clevis and pin at brake pedal installing portion.
 [Depress brake pedal pad with a force of less than 10 N (1 kgf, 2 lb) to a stroke of 1 to 3 mm (0.04 to 0.12 in).]
- (3) Depress the surface of brake pad by hand.
- (4) If there is no free play between clevis pin and clevis, turn brake switch adjusting nut until the clearance between stopper and screw of brake switch becomes 0.3 mm (0.012 in).

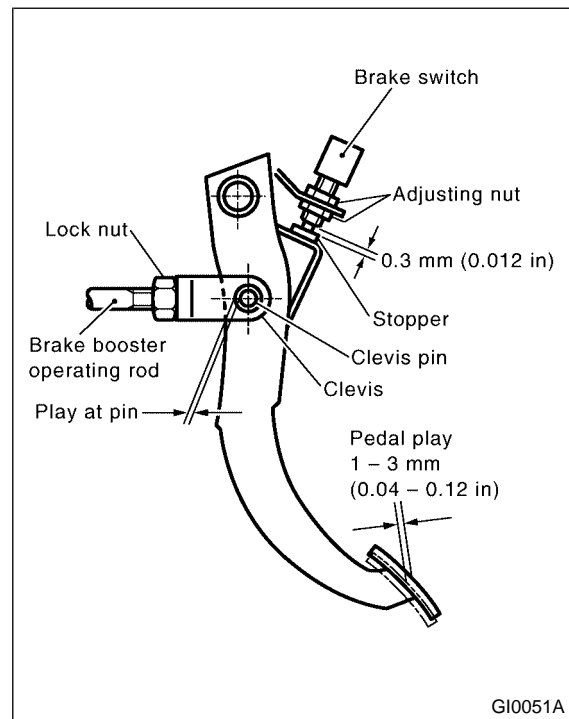

BRAKE LINE

Periodic Maintenance Services

3) Check the pedal stroke.

While the engine is idling, depress the brake pedal with a 490 N (50 kgf, 110 lb) load and measure the distance between the brake pedal and steering wheel. With the brake pedal released, measure the distance between the pedal and steering wheel again. The difference between the two measurements must be less than 95 mm (3.74 in). If the distance is more than specified, there is a possibility air is in the inside of the hydraulic unit.

Brake pedal reserve distance: A
more than 95 mm (3.74 in)/ 490 N (50 kgf, 110 lb)

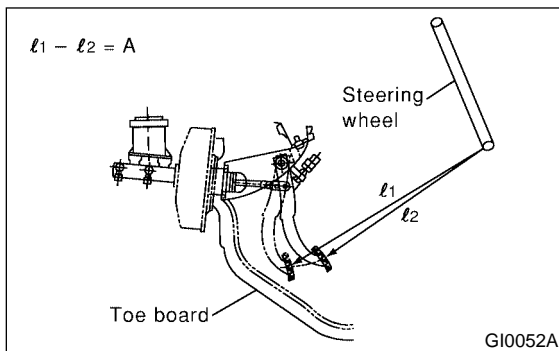

4) Check to see if air is in the hydraulic brake line by the feel of pedal operation. If air appears to exist in the line, bleed it from the system.

5) Check for even operation of all brakes, using a brake tester or by driving the vehicle for a short distance on a straight road.

2. BRAKE SERVO SYSTEM SA07694G2702

1) With the engine off, depress the brake pedal several times applying the same pedal force: Make sure the travel distance should not change.

2) With the brake pedal depressed, start the engine: Make sure the pedal should move slightly toward the floor.

3) With the brake pedal depressed, stop the engine and keep the pedal depressed for 30 seconds: Make sure the pedal height should not change.

4) Check valve is built into vacuum hose. Disconnect vacuum hose to inspect function of check valve.

Blow air into vacuum hose from its brake booster side end: Air must flow out of engine side end of hose. Next blow air into hose from engine side: Air should not flow out of hose.

Replace both check valve and vacuum hose if check valve is faulty. Engine side of vacuum hose is indicated by marking "ENGINE" as shown.

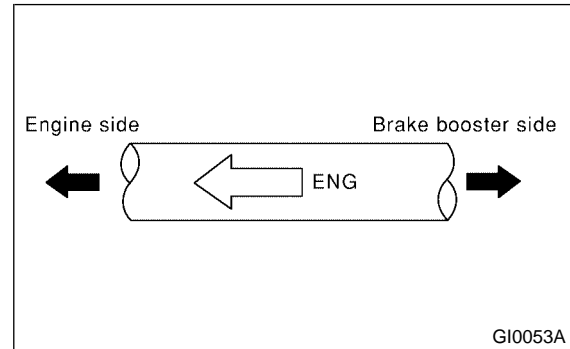

5) Check vacuum hose for cracks or other damage.

NOTE:

When installing the vacuum hose on the engine and brake booster, do not use soapy water or lubricating oil on their connections.

6) Check vacuum hose to make sure it is tight and secure.

21. Brake Fluid SA07162

A: REPLACEMENT SA07162A20

- 1) Either jack up vehicle and place a safety stand under it, or lift up vehicle.
- 2) Remove both front and rear wheels.
- 3) Draw out the brake fluid from master cylinder with syringe.
- 4) Refill reservoir tank with recommended brake fluid.

Recommended brake fluid:

FMVSS No. 116, fresh DOT3 or 4 brake fluid

NOTE:

- Avoid mixing different brands of brake fluid to prevent degrading the quality of the fluid.
- Be careful not to allow dirt or dust to get into the reservoir tank.

Bleeding sequence (1) → (2) → (3) → (4)

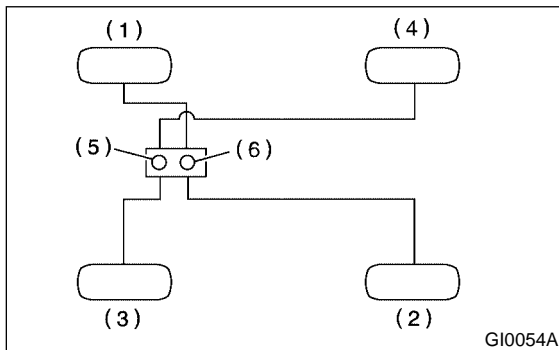

- (1) Front right
- (2) Rear left
- (3) Front left
- (4) Rear right
- (5) Secondary
- (6) Primary

- 5) Install one end of a vinyl tube onto the air bleeder and insert the other end of the tube into a container to collect the brake fluid.

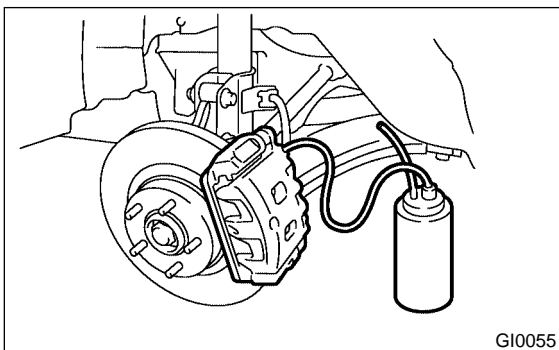

NOTE:

- Cover bleeder with waste cloth, when loosening it, to prevent brake fluid from being splashed over surrounding parts.
 - During bleeding operation, keep the brake reserve tank filled with brake fluid to eliminate entry of air.
 - Brake pedal operation must be very slow.
 - For convenience and safety, it is advisable to have two men working.
 - The amount of brake fluid required is approximately 500 ml (16.9 US fl oz, 17.6 Imp fl oz) for total brake system.
- 6) Instruct your co-worker to depress the brake pedal slowly two or three times and then hold it depressed.
 - 7) Loosen bleeder screw approximately 1/4 turn until a small amount of brake fluid drains into container, and then quickly tighten screw.
 - 8) Repeat steps 6) and 7) above until there are no air bubbles in drained brake fluid and new fluid flows through vinyl tube.

NOTE:

Add brake fluid as necessary while performing the air bleed operation, in order to prevent the tank from running short of brake fluid.

- 9) After completing the bleeding operation, hold brake pedal depressed and tighten screw and install bleeder cap.

Tightening torque:

8 N·m (0.8 kgf·m, 5.8 ft·lb)

- 10) Bleed air from each wheel cylinder by following the previous 5 steps.
- 11) Depress brake pedal with a force of approximately 294 N (30 kgf, 66 lb) and hold it there for approximately 20 seconds. At this time check pedal to see if it makes any unusual movement. Visually inspect bleeder screws and brake pipe joints to make sure that there is no fluid leakage.
- 12) Install wheels, and drive vehicle for a short distance between 2 to 3 km (1 to 2 miles) to make sure that brakes are operating properly.

DISC BRAKE PADS AND DISCS

Periodic Maintenance Services

22. Disc Brake Pads and Discs

SA07695

A: INSPECTION

SA07695A10

1. DISC BRAKE PAD AND DISC

SA07695A1001

- 1) Jack up vehicle and support with rigid racks. Then remove wheels.
- 2) Visually check pad thickness through inspection hole of disc brake assembly. Replace pad if necessary.

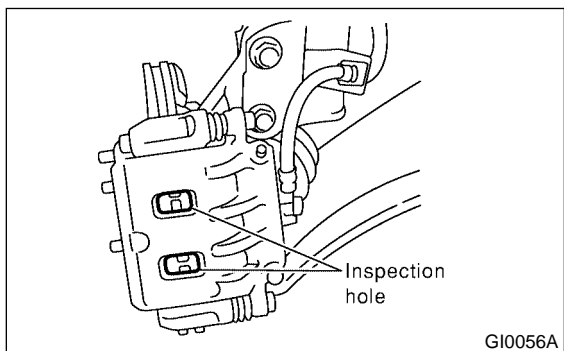

NOTE:

When replacing a pad, always replace the pads for both the left and right wheels at the same time. Also replace pad clips if they are twisted or worn.

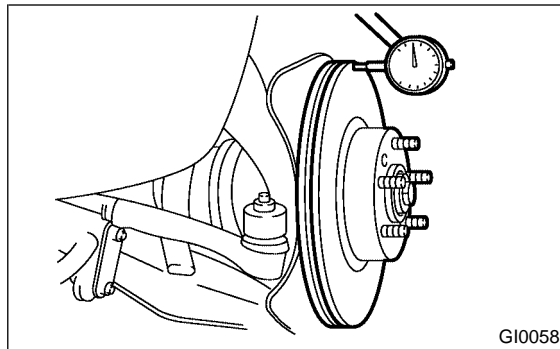

Pad thickness including back metal mm (in)		
	Front	Rear
Standard	17 (0.67)	14 (0.55)
Service limit	7.5 (0.295)	6.5 (0.256)
Service limit (exclusive back metal)	1.5 (0.059)	1.5 (0.059)

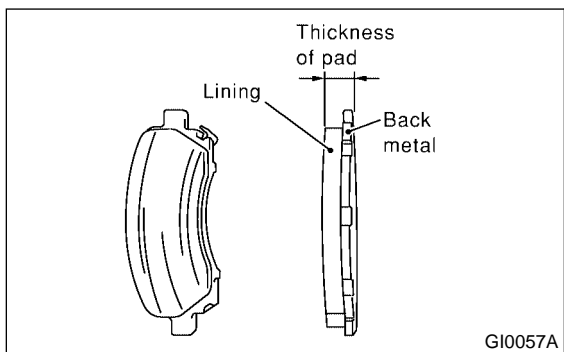

- 3) Check the disc rotor, and correct or replace if it is damaged or worn.

Brake disc thickness mm (in)		
	Front	Rear
Standard	24 (0.94)	10 (0.39)
Wear limit	22 (0.87)	8.5 (0.335)

- 4) Measure the disc rotor runout at a point less than 5 mm (0.20 in) from the outer periphery of the rotor.

Disc rotor runout limit:

Front: 0.075 mm (0.0030 in)

Rear: 0.075 mm (0.0030 in)

23. Brake Linings and Drums

SA07696

A: INSPECTION

SA07696A10

1. REAR DRUM BRAKE

SA07696A1001

- 1) Remove brake drum, and check that there is no fluid leakage from wheel cylinder. If there is fluid leakage from wheel cylinder, replace it. <Ref. to BR-34, Rear Drum Brake Drum.>
- 2) Inspect brake shoes for damage or deformities and check brake linings for wear.

NOTE:

- Always replace both leading and trailing brake shoes for the left and right wheels at the same time.
- When either the left or the right brake assembly is replaced, always replace the leading shoe and trailing shoe of the other.
- The cotter pin, once removed, cannot be reused.

Thickness of lining (except back metal)

Standard value: 4.1 mm (0.161 in)

Service limit: 1.5 mm (0.059 in)

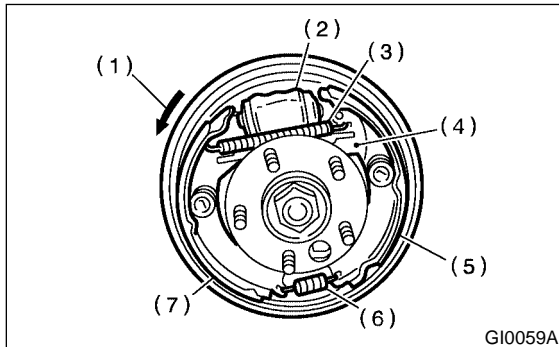

GI0059A

- (1) Rotational direction of drum (Forward)
- (2) Wheel cylinder
- (3) Upper shoe return spring
- (4) Adjusting lever
- (5) Trailing shoe
- (6) Lower shoe return spring
- (7) Leading shoe

To replace trailing shoe, remove cotter pin. Clevis pin should also be replaced if worn.

- 3) Check brake drum for wear, dents or other damage.

If the inside surface of brake drum is streaked, correct the surface with emery cloth (#200 or more). If it is unevenly worn, tapered, or the outside surface of brake drum is damaged, correct or replace it.

Brake drum inner diameter

Standard value: 228.6 mm (9.000 in)

Service limit: 230.6 mm (9.079 in)

If deformation or wear of back plate, shoe, etc. is noticeable, replace the affected parts.

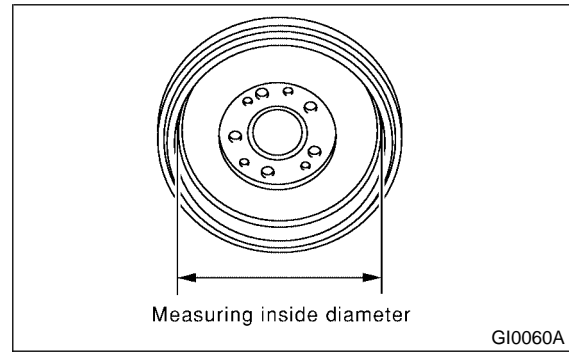

Measuring inside diameter

GI0060A

2. PARKING BRAKE (REAR DISC BRAKE)

SA07696A1002

Inspect brake linings and drums of both sides of the rear brake at the same time by removing brake drums.

- 1) Inspect brake shoes for damage or deformation and check brake linings for wear.

NOTE:

Always replace both primary and secondary brake shoes for the left and right wheels at the same time.

Brake lining thickness excluding back metal

Standard value: 3.2 mm (0.126 in)

Wear limit: 1.5 mm (0.059 in)

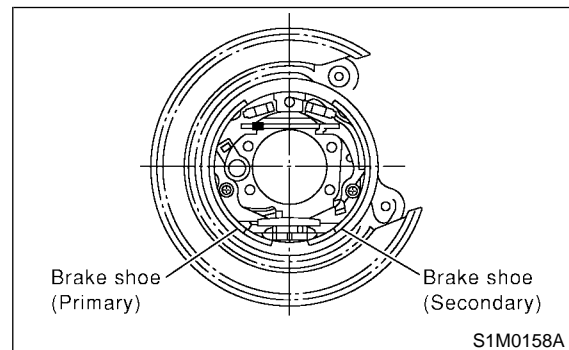

S1M0158A

BRAKE LININGS AND DRUMS

Periodic Maintenance Services

2) Check brake drum for wear, dents or other damage. If the inside surface of brake drum is streaked, correct the surface with emery cloth (#200 or more). If it is unevenly worn, tapered, or the outside surface of brake drum is damaged, correct or replace it.

Brake drum inside diameter

Standard value: 170 mm (6.69 in)

Wear limit: 171 mm (6.73 in)

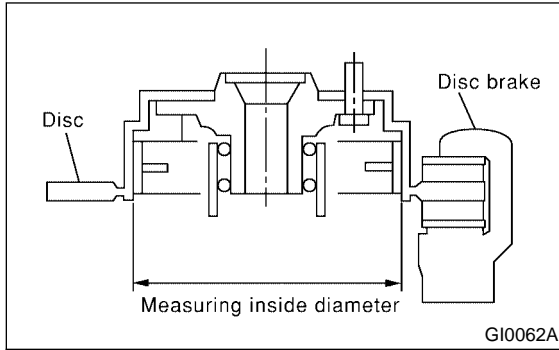

- 3) If the deformation or wear of back plate, shoe, etc. is noticeable, replace them.
- 4) When the shoe return spring tension is excessively weakened, replace it, taking care to identify upper and lower springs.

B: ADJUSTMENT

SA07696A01

1. REAR DRUM BRAKE

SA07696A0101

The main brake is adjusted automatically, and so there is no need to adjust it.

2. PARKING BRAKE (REAR DISC BRAKE)

SA07696A0102

For rear disc brake, adjust parking brake after bleeding the air.

- 1) Remove rear cover (rubber) installed at back plate.
- 2) Turn adjuster toward arrow mark (upward) until it is locked slightly, by using slot-type screwdriver as shown in illustration.

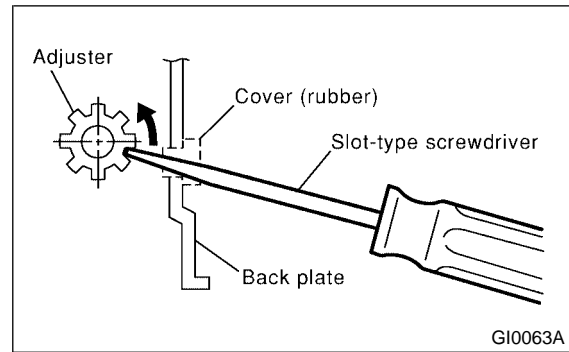

- 3) Turn back (downward) adjuster 3 to 4 notches.
- 4) Install cover (rubber) at original position correctly.

24. Suspension SA07697

A: INSPECTION SA07697A10

1. SUSPENSION BALL JOINT SA07697A1001

- 1) Jack up vehicle until front wheels are off ground.
- 2) Next, grasp bottom of tire and move it in and out. If relative movement is observed between brake disc cover and end of transverse link, ball joint may be excessively worn.
- 3) Next, grasp end of transverse link and move it up and down. Relative movement between housing and transverse link boss indicates ball joint may be excessively worn.
- 4) If relative movement is observed in the immediately preceding two steps, remove and inspect ball joint. If free play exceeds standard, replace ball joint. <Ref. to FS-17, Front Ball Joint.>

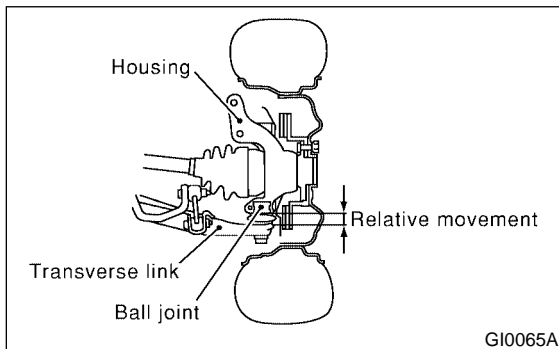
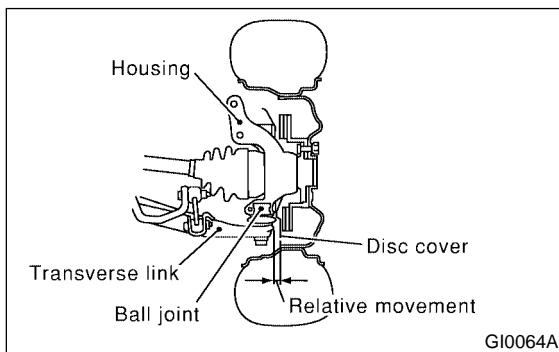

- 5) Damage of dust seal
Visually inspect ball joint dust seal. If it is damaged, remove transverse link. <Ref. to FS-14, Front Transverse Link.> And measure free play of ball joint. <Ref. to FS-17, Front Ball Joint.>
 - (1) When looseness exceeds standard value, replace ball joint.
 - (2) If the dust seal is damaged, replace with the new ball joint.

NOTE:

When transverse link ball joint has been removed or replaced, check toe-in of front wheel. If front wheel toe-in is not at specified value, adjust toe-in. <Ref. to FS-6, Wheel Alignment.>

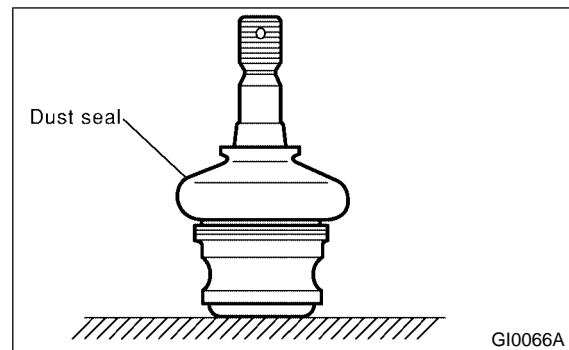

2. TRANSVERSE LINK'S REAR BUSHING SA07697A1002

Check oil leaks at around liquid-filled bushing. If oil leaks, replace bushing.

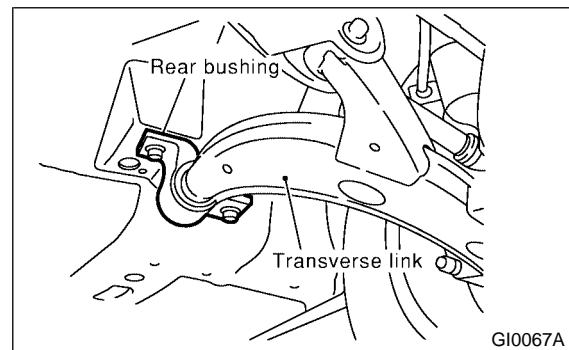

3. WHEEL ARCH HEIGHT SA07697A1003

- 1) Unload cargoes and set vehicle in curb weight condition.
- 2) Then, check wheel arch height of front and rear suspensions to ensure that they are within specified values.
- 3) When wheel arch height is out of standard, visually inspect following components and replace deformed parts.
 - Suspension components [Front strut assembly and rear strut assembly]
 - Body parts to which suspensions are installed.
- 4) When no components are deformed, adjust wheel arch height by replacing coil spring in the suspension whose wheel arch height is out of standard. <Ref. to FS-6, Wheel Alignment.> and <Ref. to RS-7, Wheel Alignment.>

SUSPENSION

Periodic Maintenance Services

4. WHEEL ALIGNMENT OF FRONT SUSPENSION

SA07697A1004

1) Check alignment of front suspension to ensure that following items conform to standard values.

- Toe-in
- Camber angle
- Caster angle
- Steering angle

<Ref. to FS-6, Wheel Alignment.>

2) When caster angle does not conform to standard value, visually inspect following components and replace deformed parts.

- Suspension components [Strut assembly, crossmember, transverse link, etc.]
- Body parts to which suspensions are installed.

3) When toe-in and camber are out of standard value, adjust them so that they conform to respective service standard.

4) When right-and-left turning angles of tire are out of standard, adjust to standard value.

5. WHEEL ALIGNMENT OF REAR SUSPENSION

SA07697A1005

1) Check alignment of rear suspension to ensure that following items are within standard values.

- Toe-in
- Camber angle
- Thrust angle

<Ref. to RS-7, Wheel Alignment.>

2) When camber angle does not conform to standard value, visually inspect parts listed below. If deformation is observed, replace damaged parts.

- Suspension components [Strut assembly, crossmember, lateral link, etc.]
- Body parts to which suspensions are installed.

3) When toe-in and thrust angle are out of standard value, adjust them so that they conform to respective service standard.

6. OIL LEAKAGE OF STRUT

SA07697A1009

Visually inspect front strut and rear strut for oil leakage as instructed. Replace front strut and rear strut if oil leaks excessively.

7. TIGHTNESS OF BOLTS AND NUTS

SA07697A1007

Check bolts and nuts shown in the figure for looseness. Retighten bolts and nuts to specified torque. If self-lock nuts and bolts are removed, replace them with new ones.

Front suspension: <Ref. to FS-2, General Description.>

Rear suspension: <Ref. to RS-2, General Description.>

8. DAMAGE TO SUSPENSION PARTS

SA07697A1008

1) Check the following parts and the fastening portion of the vehicle body for deformation or excessive rusting which impairs the suspension. If necessary, replace damaged parts with new ones. If minor rust formation, pitting, etc. are noted, remove rust and apply remedial anti-corrosion measures.

- Front suspension
 - Transverse link
 - Crossmember
 - Strut
- Rear suspension
 - Lateral link
 - Crossmember
 - Strut

● In the district where salt is sprayed to melt snow on a road in winter, check suspension parts for damage caused by rust every 12 months after lapse of 60 months. Take rust prevention measure as required.

25. Wheel Bearing SA07698

A: INSPECTION SA07698A10

1. FRONT WHEEL BEARING SA07698A1001

NOTE:

Inspect the condition of front wheel bearing grease.

- 1) Jack up the front of vehicle.
- 2) While holding front wheel by hand, swing it in and out to check bearing free play.
- 3) Loosen wheel nuts and remove front wheel.
- 4) If bearing free play exists in step 2) above, attach a dial gauge to hub and measure axial displacement in axial direction.

Service limit:

***Straight-ahead position within 0.05 mm
(0.0020 in)***

- 5) Remove bolts and self-locking nuts, and extract transverse link from front crossmember.
 - 6) While lightly hammering spring pin which secures S.F.J. to transmission spindle, remove it.
 - 7) Extract S.F.J. from transmission spindle. <Ref. to DS-17, Front Axle.>
 - 8) While supporting front drive shaft horizontally with one hand, turn hub with the other to check for noise or binding.
- If hub is noisy or binds, disassemble front axle and check condition of oil seals, bearing, etc.

- 6) While supporting rear drive shaft horizontally with one hand, turn hub COMPL with the other to check for noise or binding.
- If hub COMPL is noisy or binds, disassemble rear axle and check condition of oil seals, bearings, etc.

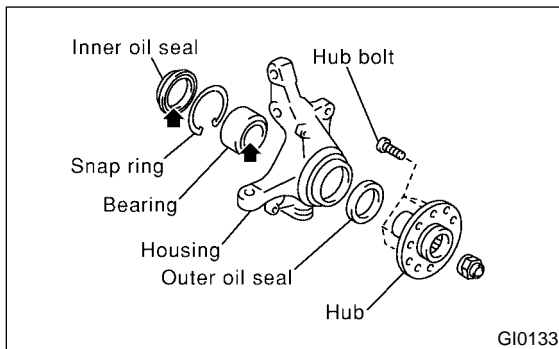
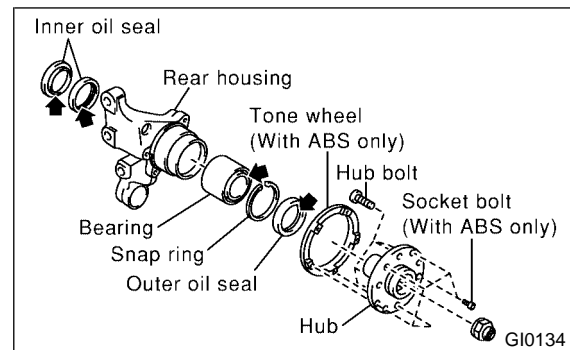

2. REAR WHEEL BEARING SA07698A1002

- 1) Jack up the rear of vehicle.
- 2) While holding rear wheel by hand, swing it in and out to check bearing free play.
- 3) Loosen wheel nuts and remove rear wheel.
- 4) If bearing free play exists in step 2) above, attach a dial gauge to hub COMPL and measure axial displacement in axial direction.

Service limit:

***Straight-ahead position within 0.05 mm
(0.0020 in)***

- 5) Remove the DOJ of rear drive shaft from rear differential. <Ref. to DS-38, Rear Drive Shaft.>

26. Axle Boots & Joints SA07699

A: INSPECTION SA07699A10

1. FRONT AND REAR AXLE BOOTS SA07699A1001

Inspect front axle boots (A) and rear axle boots (B) for deformation, damage or failure. If faulty, replace them with new ones. <Ref. to DS-32, Front Drive Shaft.> and <Ref. to DS-38, Rear Drive Shaft.>

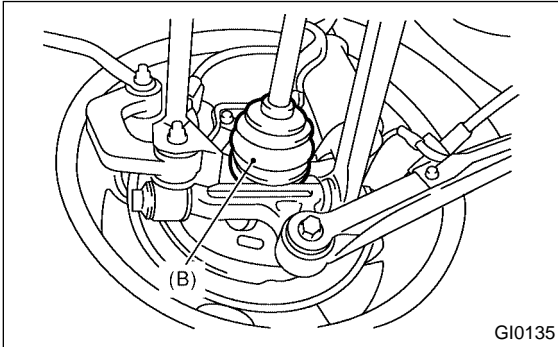
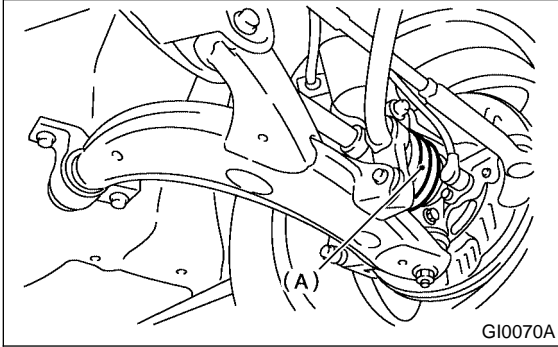

2. PROPELLER SHAFT SA07699A1002

Inspect propeller shaft for damage or failure. If faulty, replace with new one. <Ref. to DS-14, Propeller Shaft.>

27. Steering System (Power Steering) SA07701

A: INSPECTION SA07701A10

1. STEERING WHEEL SA07701A1001

- 1) Set steering wheel in a straight-ahead position, and check wheel spokes to make sure they are correctly set in their specified positions.
 - 2) Lightly turn steering wheel to the left and right to determine the point where front wheels start to move.
- Measure the distance of the movement of steering wheel at the outer periphery of wheel.

Steering wheel free play:
0 — 17 mm (0 — 0.67 in)

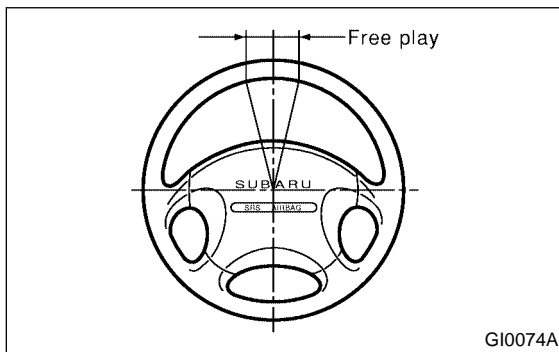

Move steering wheel vertically toward the shaft to ascertain if there is play in the direction.

Maximum permissible play:
0.5 mm (0.020 in)

- 3) Drive vehicle and check the following items during operation.
 - (1) Steering force
 The effort required for steering should be smooth and even at all points, and should not vary.
 - (2) Pull to one side
 Steering wheel should not be pulled to either side while driving on a level surface.
 - (3) Wheel runout
 Steering wheel should not show any sign of runout.
 - (4) Return factor
 Steering wheel should return to its original position after it has been turned and then released.

2. STEERING SHAFT JOINT SA07701A1002

- 1) When steering wheel free play is excessive, disconnect universal joint of steering shaft and check it for any play and yawing torque (at the point of the crossing direction). Also inspect for any damage to sealing or worn serrations. If the joint is loose, retighten the mounting bolts to the specified torque.

Tightening torque:
24 N·m (2.4 kgf·m, 17.4 ft·lb)

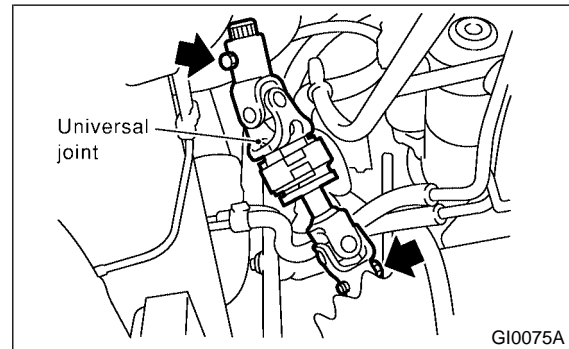

3. GEARBOX SA07701A1003

- 1) With wheels placed on a level surface, turn steering wheel 90° in both the left and right directions. While wheel is being rotated, reach under vehicle and check for looseness in gearbox.

Tightening torque:
59 N·m (6.0 kgf·m, 43.4 ft·lb)

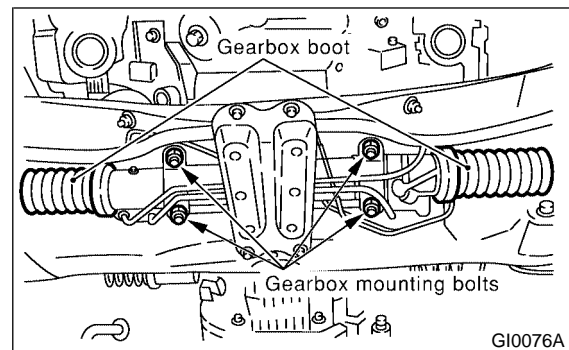

- 2) Check boot for damage, cracks or deterioration.

STEERING SYSTEM (POWER STEERING)

Periodic Maintenance Services

3) With vehicle on a level surface, quickly turn steering wheel to the left and right.

While steering wheel is being rotated, check the gear backlash. If any unusual noise is noticed, adjust the gear backlash in the following manner.

(1) Loosen the adjusting screw three to four rotations.

(2) Apply liquid packing to at least 1/3 of entire perimeter of adjusting screw thread.

(3) Tighten adjusting screw to 7.4 N·m (0.75 kgf-m, 5.4 ft-lb) and then loosen. Repeat this operation twice.

(4) Retighten adjusting screw to 7.4 N·m (0.75 kgf-m, 5.4 ft-lb) and back off 25°.

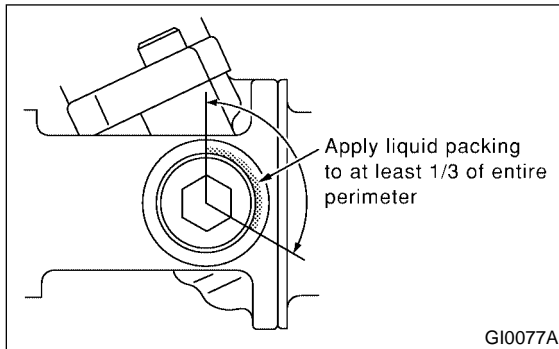

(5) Install lock nut. While holding adjusting screw with a wrench, tighten lock nut using ST. ST 926230000 SPANNER

Tightening torque (Lock nut):
39 N·m (4.0 kgf-m, 29 ft-lb)

Hold the adjusting screw with a wrench to prevent it from turning while tightening the lock nut.

4. TIE-ROD SA07701A1004

1) Check tie-rod and tie-rod ends for bends, scratches or other damage.

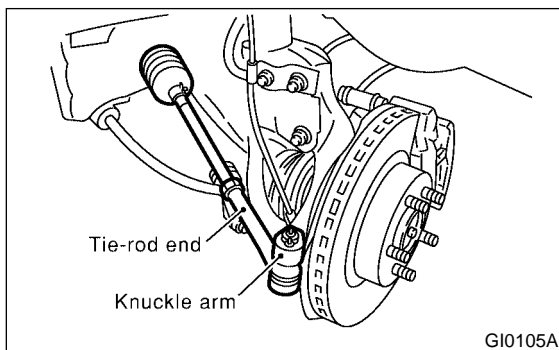

2) Check connections of knuckle ball joints for play, inspect for damage on dust seals, and check free play of ball studs. If castle nut is loose, retighten it to the specified torque, then tighten further up to 60° until cotter pin hole is aligned.

Tightening torque:
27 N·m (2.75 kgf-m, 19.9 ft-lb)

3) Check lock nut on the tie-rod end for tightness. If it is loose, retighten it to the specified torque.

Tightening torque:
83 N·m (8.5 kgf-m, 61.5 ft-lb)

5. POWER STEERING FLUID LEVEL

SA07701A1005

1) Check power steering fluid for deterioration or contamination. If the fluid is highly deteriorated or contaminated, drain it and refill with new fluid.

2) Check joints and units for oil leakage. If any oil leaks are found, repair or replace the applicable part.

3) Inspect fluid level on flat and level surface with engine "OFF" by indicator of reservoir tank.

If the level is at lower point or below, add fluid to keep the level in the specified range of the indicator. If at upper point or above, drain fluid by using a syringe or the like.

(1) Check at temperature 20°C (68°F) on reservoir surface of oil pump; read the fluid level on the "COLD" side.

(2) Check at temperature 80°C (176°F) on reservoir surface of oil pump; read the fluid level on the "HOT" side.

Non-turbo model

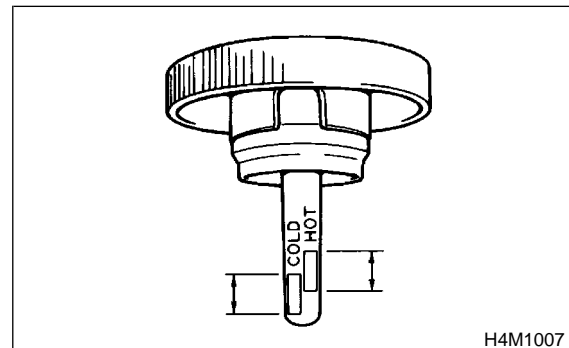

Turbo model

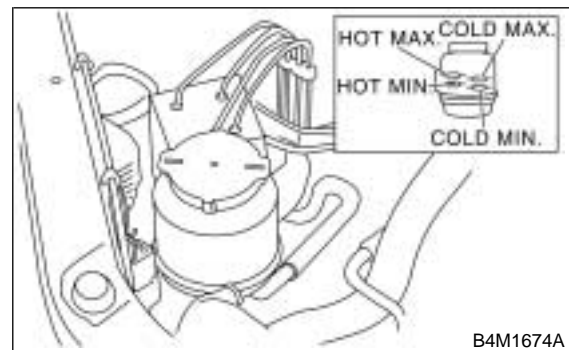

NOTE:

If fluid level is at MAX level or above, drain fluid to keep the level in the specified range of indicator by using a syringe or the like.

Recommended fluid:
Dexron IIE or III

Fluid capacity:
0.7 l (0.7 US qt, 0.6 Imp qt)

6. POWER STEERING FLUID FOR LEAKS

SA07701A1006

Inspect the underside of oil pump and gearbox for power steering system, hoses, piping and their couplings for fluid leaks.

If fluid leaks are found, correct them by retightening their fitting bolts (or nuts) and/or replacing their parts.

NOTE:

- Wipe the leakage fluid off after correcting fluid leaks, or a wrong diagnosis is taken later.
- Also pay attention to clearances between hoses (or pipings) and other parts when inspecting fluid leaks.

7. HOSES OF OIL PUMP FOR DAMAGES

SA07701A1007

Check pressure hose and return hose of oil pump for crack, swell or damage. Replace hose with new one if necessary.

NOTE:

Prevent hoses from revolving and/or turning when installing hoses.

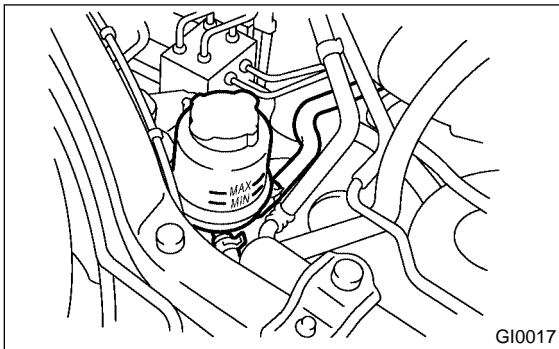

8. POWER STEERING PIPES FOR DAMAGE

SA07701A1008

Check power steering pipes for corrosion and damage.

Replace pipes with new one if necessary.

9. GEARBOX BOOTS

SA07701A1009

Inspect both sides of gearbox boots as follows, and correct the defects if necessary.

1) (A) and (B) positions of gearbox boot are fitted correspondingly in (A) and (B) grooves of gearbox and the rod.

2) Clips are fitted outside of (A) and (B) positions of boot.

3) Boot does not have crack and hole.

NOTE:

Rotate (B) position of gearbox boot against twist of it produced by adjustment of toe-in, etc.

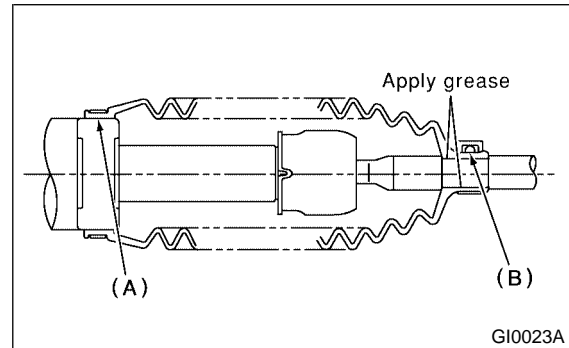

10. FITTING BOLTS AND NUTS

SA07701A1010

Inspect fitting bolts and nuts of oil pump and bracket for looseness, and retighten them if necessary.

Inspect and/or retighten them when engine is cold.

SUPPLEMENTAL RESTRAINT SYSTEM

Periodic Maintenance Services

28. Supplemental Restraint System SA07702

A: INSPECTION SA07702A10

Check the airbag system in accordance with the result of the self-diagnosis. <Ref. to AB-2, Basic Diagnostic Procedure.>

1) Ensure that airbag connectors are connected. If not, properly connect (also double lock the connector). When the ignition switch is turned ON with the connector(s) disconnected, the airbag warning light turns on to identify the fault.

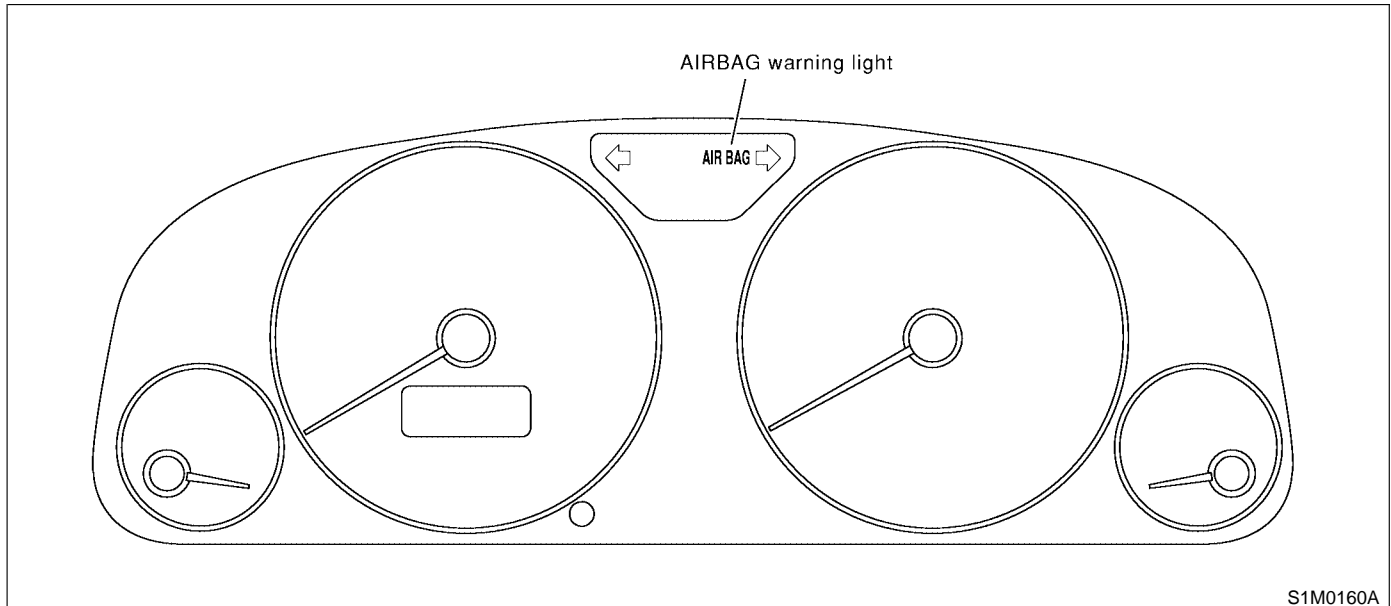

2) Turn the ignition switch ON, and connect the airbag diagnosis terminal of the service connector (located below lower cover) to the ground terminal.

3) The warning light blinks to indicate a trouble code (a fault is identified). When the airbag system is in good order (no trouble codes are stored in the memory), the warning light blinks on and off at 0.6 second intervals (as long as the diagnosis terminal is connected to the ground terminal).

4) When the warning light indicates a trouble code, check the airbag system in accordance with the troubleshooting procedure. <Ref. to AB-2, Basic Diagnostic Procedure.>