

HANDBOOK

DS 5



DS AUTOMOBILES



# On-line handbook

Select one of the following means of access to view your handbook on-line...

Find your handbook on the CITROËN website, under "MyCITROËN".

This personal and customisable space allows you to establish direct and special contact with CITROËN.

---

Referring to the handbook on-line also gives you access to the latest information available, easily identified by the bookmark, associated with this symbol:



If the "MyCITROËN" function is not available on the CITROËN public website for your country, you can find your handbook at the following address:

<http://service.citroen.com/ddb/>

Select:

- > the language,
  - > the vehicle, its body style,
  - > the print edition of your handbook appropriate for the date of registration of your vehicle.
- 

Scan this code for direct access to your handbook.





DS AUTOMOBILES

This handbook covers all of the variations in equipment available across the whole DS 5 range. Your vehicle will be fitted with only some of the equipment described in this document, depending on its trim level, version and the specification for the country in which it was sold.

The descriptions and illustrations are given as indications only. Automobiles CITROËN reserves the right to modify the technical characteristics, equipment and accessories without having to update this edition of the handbook.

This document forms an integral part of your vehicle. Remember to pass it on to the new owner in the event of the sale of the vehicle.

We thank you for having chosen a DS 5.

This handbook has been designed to help you to make the most of your vehicle in all circumstances and in complete safety.

Take the time to read through it.

Happy motoring!

# Contents

Key

 safety warning

 additional information

 contributes to the protection of the environment

**6** OVERVIEW

**14** ECO-DRIVING

**308** ALPHABETICAL  
INDEX



## 001 MONITORING

- 18** Instrument panel
- 19** Indicator and warning lamps
- 32** Gauges and indicators
- 37** Distance recorders
- 38** Clock
- 39** Monochrome screen C
- 43** Touch screen
- 46** Trip computer



## 002 ACCESS

- 52 Electronic key - remote control
- 54 Keyless Entry and Starting
- 61 Central locking
- 62 Boot
- 63 Alarm
- 66 Electric windows
- 68 Cockpit glass roof



## 003 COMFORT

- 72 Front seats
- 77 Rear seats
- 80 Mirrors
- 81 Steering wheel adjustment
- 82 Front fittings
- 86 Rear fittings
- 87 Boot fittings
- 88 Triangle (stowing)
- 89 Heating and Ventilation
- 91 Dual-zone digital air conditioning
- 95 Front demist - defrost
- 95 Rear screen demist - defrost



## 004 DRIVING

- 98 Driving recommendations
- 100 Starting / Switching off the engine
- 103 Electric parking brake
- 109 Hill start assist
- 110 Manual gearbox
- 111 Automatic gearbox
- 115 Gear shift indicator
- 116 Tyre under-inflation detection
- 118 Stop & Start
- 122 Lane departure warning system
- 123 Blind spot sensors
- 126 Head-up display
- 128 Memorising speeds
- 130 Speed limiter
- 133 Cruise control
- 136 Parking sensors
- 138 Reversing camera



## 005 VISIBILITY

- 142 Lighting controls
- 145 Daytime running lamps / Sidelamps (LEDs)
- 146 Automatic illumination of headlamps
- 147 Automatic headlamp dipping
- 149 Side spotlamps
- 150 Headlamp beam height adjustment
- 151 Directional lighting
- 153 Wiper controls
- 155 Automatic rain sensitive wipers
- 157 Courtesy lamps
- 158 Interior mood lighting

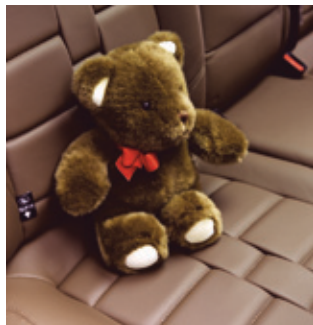

## 006 CHILD SAFETY

- 162 Child seats
- 164 Deactivating the passenger's front airbag
- 170 ISOFIX mountings
- 176 Child lock



## 007 SAFETY

- 180 Direction indicators
- 181 Emergency or assistance call
- 181 Horn
- 182 ESC system
- 186 Seat belts
- 189 Airbags



## 008 PRACTICAL INFORMATION

- 196 Temporary puncture repair kit
- 202 Changing a wheel
- 211 Changing a bulb
- 219 Changing a fuse
- 223 12 V battery
- 227 Energy economy mode
- 228 Changing a wiper blade
- 229 Towing the vehicle
- 231 Towing a trailer
- 232 Fitting roof bars
- 233 Advice on care and maintenance
- 234 Accessories



## 009 CHECKS

- 239 Fuel tank
- 242 Misfuel prevention (Diesel)
- 243 Opening the bonnet
- 244 Petrol underbonnet layout
- 245 Diesel underbonnet layout
- 246 Running out of fuel (Diesel)
- 247 Checking levels
- 251 Checks
- 253 AdBlue® additive and SCR system (BlueHDi Diesel)



## 010 TECHNICAL DATA

- 264 Petrol engines
- 265 Petrol weights
- 267 Diesel engines
- 269 Diesel weights
- 273 Dimensions
- 274 Identification markings



## 011 AUDIO AND TELEMATICS

- 278 Emergency or assistance
- 281 Audio system



For versions equipped with a navigation system in the touch screen, refer to the supplement in the handbook pack.

# Overview





# Exterior

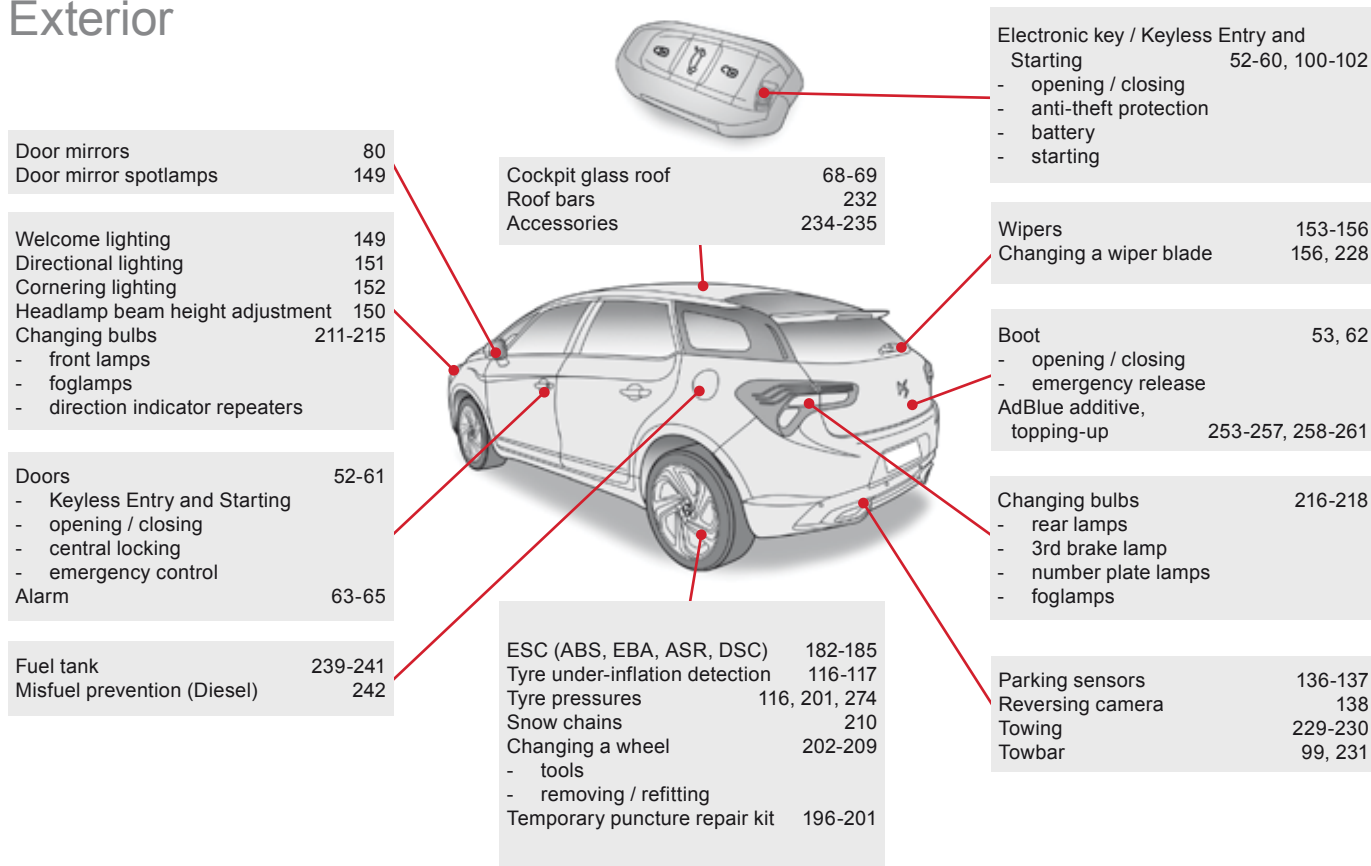

# Interior

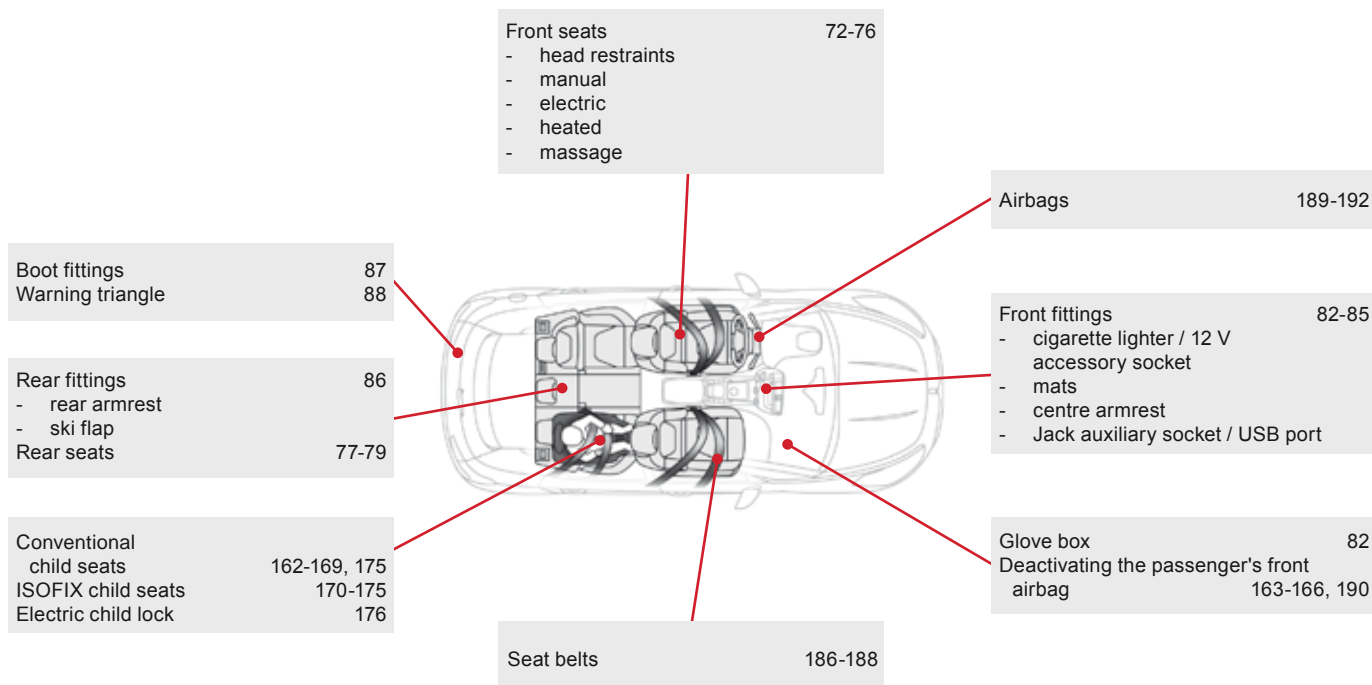

# Instruments and controls

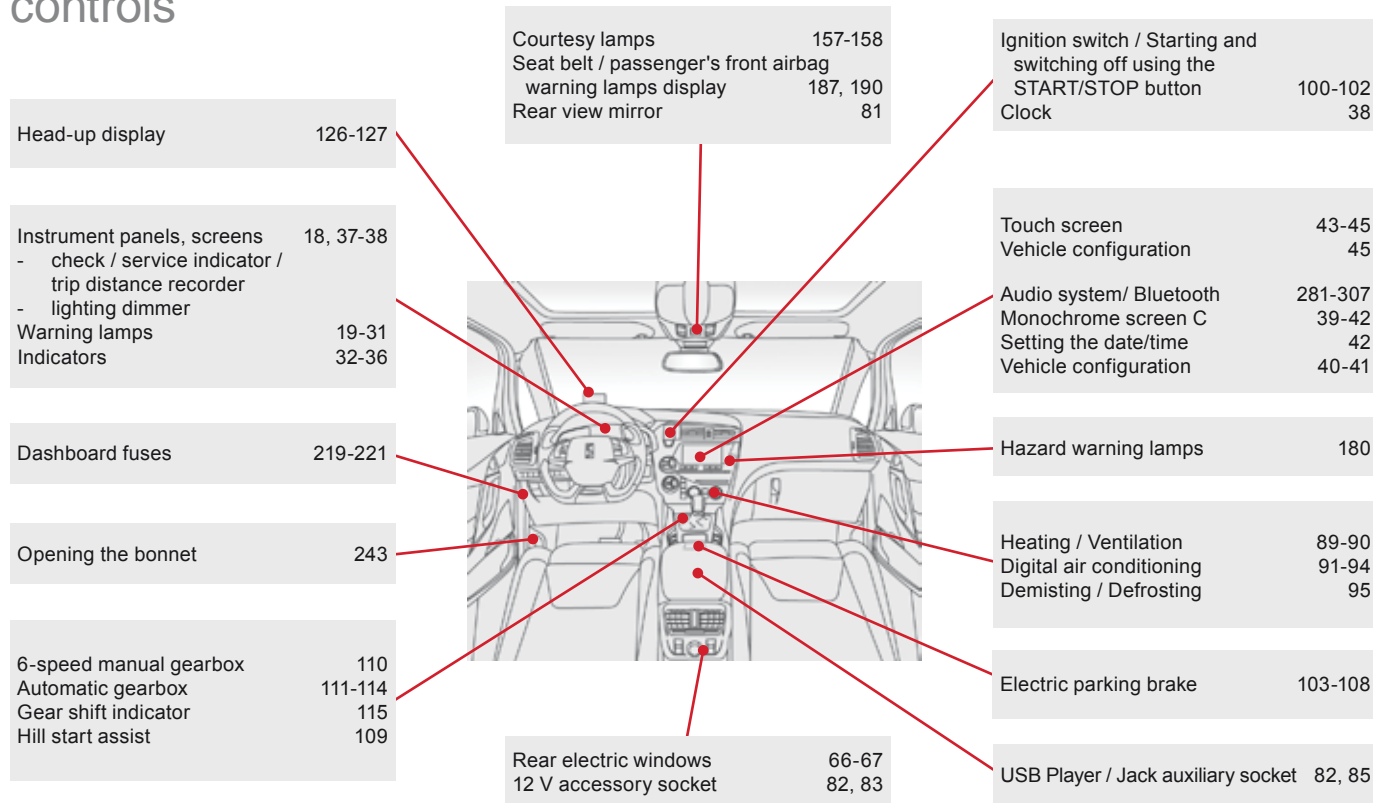



# Instruments and controls

## Multifunction steering wheel

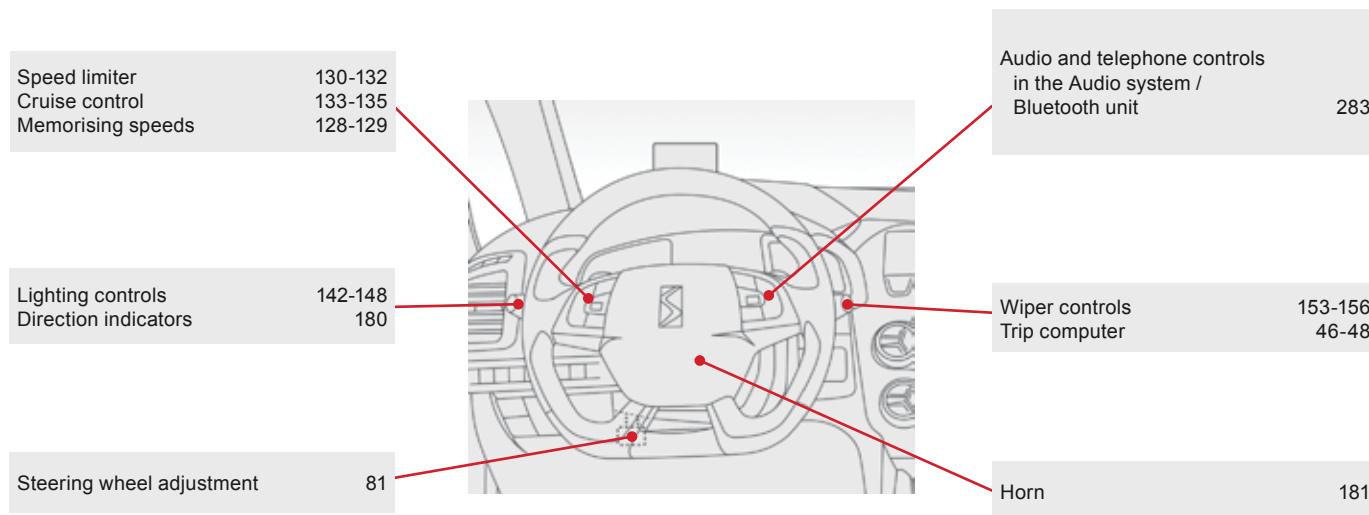

# Instruments and controls

## Side switch panel

Parking sensors	136-137
DSC/ASR systems	184-185
Stop & Start or Blind spot sensors	118-121 123-125

Opening the fuel filler flap	239
Opening the boot	62

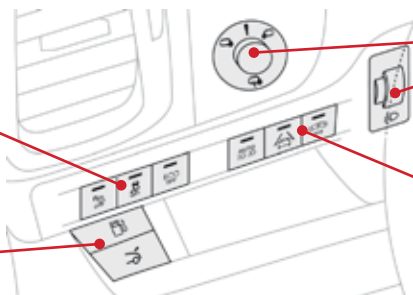

Door mirrors	80
Headlamp height adjustment	150

Automatic headlamps	147-148
Lane departure warning system	122
Volumetric alarm monitoring	63-65

## Centre switch panel

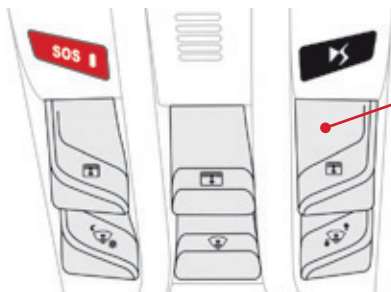

Localised emergency call	181, 278-279
Localised assistance call	181, 278-279
Cockpit glass roof	68-69
Head-up display	126-127

Electric windows, front/rear	66-67
Electric child lock	176
Central locking	61

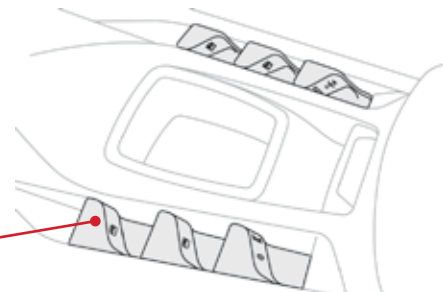

# Maintenance - Technical data

Running out of fuel (Diesel) 246

Petrol engines 264  
Diesel engines 267-268

12V battery 223-226  
Load reduction, economy mode 227  
Engine compartment fuses 219-220, 222

Checking levels 247-250  
- oil  
- brake fluid  
- power steering fluid  
- coolant  
- screenwash/headlamp wash fluid  
AdBlue additive 253-261  
Checking components 251-252  
- air filter  
- passenger compartment filter  
- oil filter  
- electric parking brake  
- brake pads / discs

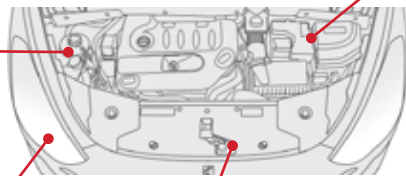

Petrol weights 265-266  
Diesel weights 269-272

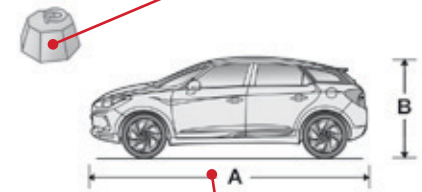

Changing bulbs 211-218  
- front  
- rear

Opening the bonnet 243  
Under the bonnet, petrol 244  
Under the bonnet, Diesel 245

Dimensions 273  
Identification markings 274

## Eco-driving

Eco-driving is a range of everyday practices that allow the motorist to optimise their fuel consumption and CO<sub>2</sub> emissions.

### Optimise the use of your gearbox

With a manual gearbox, move off gently and change up without waiting. During acceleration change up early.

With an automatic gearbox, give preference to automatic mode and avoid pressing the accelerator pedal heavily or suddenly.

The gear efficiency indicator invites you engage the most suitable gear: as soon as the indication is displayed in the instrument panel, follow it straight away.

For vehicles fitted with an automatic gearbox, this indicator appears only in manual mode.

### Drive smoothly

Maintain a safe distance between vehicles, use engine braking rather than the brake pedal, and press the accelerator progressively. These practices contribute towards a reduction in fuel consumption and CO<sub>2</sub> emissions and also helps reduce the background traffic noise.

If your vehicle has cruise control, make use of the system at speeds above 25 mph (40 km/h) when the traffic is flowing well.

### Control the use of your electrical equipment

Before moving off, if the passenger compartment is too warm, ventilate it by opening the windows and air vents before using the air conditioning. Above 30 mph (50 km/h), close the windows and leave the air vents open.

Remember to make use of equipment that can help keep the temperature in the passenger compartment down (sunroof and window blinds...).

Switch off the air conditioning, unless it has automatic regulation, as soon as the desired temperature is attained.

Switch off the demisting and defrosting controls, if not automatic. Switch off the heated seat as soon as possible.

Switch off the headlamps and front foglamps when the level of light does not require their use.

Avoid running the engine before moving off, particularly in winter; your vehicle will warm up much faster while driving.

As a passenger, if you avoid connecting your multimedia devices (film, music, video game...), you will contribute towards limiting the consumption of electrical energy, and so of fuel.

Disconnect your portable devices before leaving the vehicle.





## Limit the causes of excess consumption

Spread loads throughout the vehicle; place the heaviest items in the bottom of the boot, as close as possible to the rear seats.

Limit the loads carried in the vehicle and reduce wind resistance (roof bars, roof rack, bicycle carrier, trailer...). Use a roof box in preference.

Remove roof bars and roof racks after use.

At the end of winter, remove snow tyres and refit your summer tyres.

## Observe the recommendations on maintenance

Check the tyre pressures regularly, when cold, referring to the label in the door aperture, driver's side.

Carry out this check in particular:

- before a long journey,
- at each change of season,
- after a long period out of use.

Don't forget the spare wheel and the tyres on any trailer or caravan.

Have your vehicle serviced regularly (engine oil, oil filter, air filter, passenger compartment filter...) and observe the schedule of operations recommended in the manufacturer's service schedule.

With a BlueHDi Diesel engine, if the SCR system is faulty your vehicle becomes polluting ; go to a CITROËN dealer or a qualified workshop without delay to have the emissions of nitrous oxides brought back to the legal level.

When refuelling, do not continue after the third cut-off of the nozzle to avoid any overflow.

At the wheel of your new vehicle, it is only after the first 1 800 miles (3 000 kilometres) that you will see the fuel consumption settle down to a consistent average.

**001**

Instruments and controls



PAUSE  
0 km/h  
D  
130 km/h  
4.6 km/h  
3.56 km/h

# Petrol-Diesel instrument panel



## Dials and screens

1. Rev counter (x 1 000 rpm or tr/min), graduation according to engine (petrol or Diesel).
2. Fuel gauge.
3. Engine coolant temperature gauge.
4. Analogue speedometer (mph or km/h).
5. Cruise control or speed limiter settings.
6. Gear shift indicator or gear lever position and gear engaged for an automatic gearbox.
7. Instrument panel screen: distance recorders, service indicator, engine oil level indicator\*, remaining range for the AdBlue additive and the SCR system\*, alert messages, trip computer, media currently playing, navigation instructions\*.
8. Digital speedometer (mph or km/h).

## Control buttons

- A.** Main lighting and controls dimmer.
- B.** - Short press: display in turn of servicing information, remaining range for the AdBlue additive and the alert log.  
- Long press: reset the service indicator or trip recorder (depending on context).

\* Depending on version.

**i** When switching the ignition on or off, the speedometer needle and the bars of the dials carry out a full sweep and then return to 0.

## Indicator and warning lamps

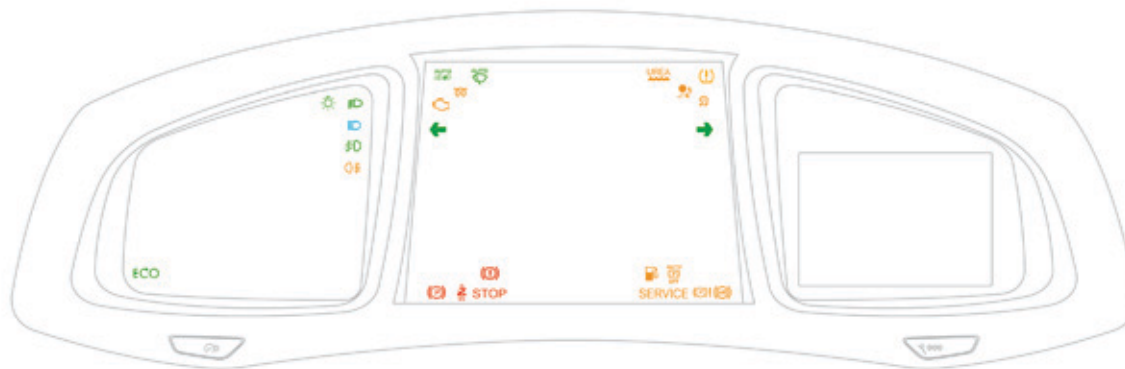

Visual indicators informing the driver that a system is in operation, switched off or has a fault.

### When the ignition is switched on

Certain warning lamps come on for a few seconds in the instrument panel and/or instrument panel screen when the vehicle's ignition is switched on.

When the engine is started, these same warning lamps should go off. If they remain on, before moving off, refer to the information on the warning lamp concerned.







### Associated warnings

The switching on of certain warning lamps may be accompanied by an audible signal and a message in the instrument panel screen. The warning lamps may come on continuously (fixed) or flash.





 Certain warning lamps may come on in one of two modes: fixed (continuous) or flashing. Only by relating the type of illumination to the operation of the vehicle can it be determined whether the situation is normal or a fault has occurred. Refer to the tables on the following page for more information.



## Operation indicator lamps

If one of the following indicator lamps comes on in the instrument panel and/or instrument panel screen, this confirms that the corresponding system has come into operation.

Warning / indicator lamp		State	Cause	Action / Observations
	<b>Left-hand direction indicator</b>	flashing with buzzer.	The lighting stalk is pushed down.	
	<b>Right-hand direction indicator</b>	flashing with buzzer.	The lighting stalk is pushed up.	
	<b>Sidelamps</b>	fixed.	The lighting stalk is in the "Sidelamps" position.	
	<b>Dipped beam headlamps</b>	fixed.	The lighting stalk is in the "Dipped beam headlamps" position.	
	<b>Main beam headlamps</b>	fixed.	The lighting stalk is pulled towards you.	Pull the stalk to return to dipped beam headlamps.
	<b>Automatic headlamp dipping</b>	fixed.	The lighting stalk has been pulled towards you and the button has been pressed. Its indicator lamp is on.	The camera, located in the interior rear view mirror, authorises or not switching between main and dipped beam, depending on the exterior lighting and the driving conditions. Pulling the lighting stalk to return to dipped beam.
	<b>Front foglamps</b>	fixed.	The front foglamps are switched on using the ring on the lighting control stalk.	Turn the ring on the lighting control stalk rearward twice to switch off the front foglamps.

 For more information on the lighting controls, refer to the corresponding section.

Warning / indicator lamp		State	Cause	Action / Observations
	<b>Rear foglamps</b>	fixed.	The rear foglamps are on.	Turn the ring on the stalk rearward to switch off the rear foglamps.
	<b>Diesel engine pre-heating</b>	fixed.	The <b>START/STOP</b> switch has been pressed (ignition on).	Wait until the warning lamp goes off before starting. Once it goes off, starting is immediate, on condition that the brake pedal remains pressed with an automatic gearbox, or the clutch pedal is pressed fully down with a manual gearbox. The period of illumination of the warning lamp is determined by the ambient conditions (up to about thirty seconds in severe winter conditions). If the engine does not start, switch the ignition off and then on, wait until the warning lamp goes off again, then start the engine.
	<b>Electric parking brake</b>	fixed.	The electric parking brake is applied.	Release the electric parking brake to switch off the warning lamp: with your foot on the brake pedal, pull the electric parking brake control lever. Observe the safety recommendations. For more information on the electric parking brake, refer to the corresponding section.
	<b>Deactivation of the automatic functions of the electric parking brake</b>	fixed.	The "automatic application" (on switching off the engine) and "automatic release" functions are deactivated or faulty.	Activate the function (depending on the country of sale) via the vehicle configuration menu or contact a CITROËN dealer or a qualified workshop if automatic application / release is not possible. For more information on the electric parking brake, refer to the corresponding section.

Warning / indicator lamp		State	Cause	Action / Observations
	<b>Automatic wiping</b>	fixed.	The wiper control is pushed downwards.	Automatic front wiping is activated. To deactivate automatic wiping, operate the control stalk downwards or put the stalk into another position.
	<b>Passenger's airbag system</b>	fixed in the seat belt and passenger's front airbag warning lamps display.	The control switch, located in the glove box, has been placed in the "ON" position. The passenger's front airbag is activated. In this case, do not install a rearward facing child seat on this seat.	Move the control switch to the "OFF" position to deactivate the passenger's front airbag. In this case, you can install a rearward facing child seat, unless there is a fault with the airbags (airbag warning lamp on).
	<b>Stop &amp; Start</b>	fixed.	When the vehicle stops (red lights, traffic jams, ...) the Stop & Start system has put the engine into STOP mode.	The warning lamp goes off and the engine restarts automatically in START mode, as soon as you want to move off.
		flashes for a few seconds, then goes off.	STOP mode is temporarily unavailable. or START mode is invoked automatically.	For more information on Stop & Start, refer to the corresponding section.





## Deactivation indicator lamps

If one of the following indicator lamps comes on, this confirms that the corresponding system has been switched off intentionally. This is may be accompanied by an audible signal and a message in the instrument panel screen.

Warning / indicator lamp	State	Cause	Action / Observations	
	<b>Passenger's airbag system</b>	fixed in the instrument panel and/or seat belt and front passenger's airbag warning lamps display.	The control switch, located in the glove box, is set to the <b>OFF</b> position. The passenger's front airbag is deactivated. You can install a rearward facing child seat, unless there is a fault with the airbags (airbag warning lamp on).	Set the control to the <b>"ON"</b> position to activate the passenger's front airbag. In this case, do not install a rearward facing child seat on this seat.

## Warning lamps



When the engine is running or the vehicle is being driven, illumination of one of the following warning lamps indicates a fault which requires action on the part of the driver.



Any fault resulting in the illumination of a warning lamp must be investigated further by reading the associated message in the instrument panel screen.



If you encounter any problems, contact a CITROËN dealer or a qualified workshop.

Warning / indicator lamp		State	Cause	Action / Observations
<b>STOP</b>	<b>STOP</b>	fixed, associated with another warning lamp, accompanied by an audible signal and a message in the screen.	Illumination of this warning lamp is related to a serious fault with the braking system, power steering, the engine oil pressure or engine coolant temperature or a major electrical fault.	Stop as soon as it is safe to do so as the engine may cut out. Park, switch off the ignition and call a CITROËN dealer or a qualified workshop.



Warning / indicator lamp	State	Cause	Action / Observations
<b>SERVICE</b>	<b>Service</b>	temporarily, accompanied by a message.	One or more minor faults for which there is no specific warning lamp have been detected.  Identify the cause of the fault using the message displayed in the screen. You can deal with some problems yourself, such as a door open or the start of saturation of the particle filter (as soon as the traffic conditions allow, regenerate the filter by driving at a speed of at least 40 mph (60 km/h), until the warning lamp goes off). For any other problems, such as a fault with the tyre under inflation detection system, contact a CITROËN dealer or a qualified workshop.
	fixed, accompanied by a message.	One or more major faults for which there is no specific warning lamp have been detected.	Identify the cause of the fault using the message displayed in the screen; you must then contact a CITROËN dealer or a qualified workshop.
	fixed, associated with the flashing and then fixed display of the service indicator spanner.	The servicing interval has been exceeded.	Only on BlueHDi Diesel versions. Your vehicle must be serviced as soon as possible.

Warning / indicator lamp		State	Cause	Action / Observations
	<b>Electric parking brake</b>	flashing.	The electric parking brake is not applied automatically. The application/release is faulty.	You must stop as soon as it is safe to do so. Park on flat level ground, engage a gear (or place the lever in position <b>P</b> for an automatic gearbox), switch off the ignition and contact a CITROËN dealer or a qualified workshop.
	<b>Electric parking brake fault</b>	fixed.	The electric parking brake has a fault.	Contact a CITROËN dealer or a qualified workshop without delay. For more information on the electric parking brake, refer to the corresponding section.
	<b>Deactivation of the automatic functions of the electric parking brake</b>	fixed.	The "automatic application" (on switching off the engine) and "automatic release" functions are deactivated or faulty.	Activate the function (depending on the country of sale) via the vehicle configuration menu or contact a CITROËN dealer or a qualified workshop if automatic application / release is not possible. For more information on the electric parking brake, refer to the corresponding section.



Warning / indicator lamp		State	Cause	Action / Observations
	<b>Braking</b>	fixed.	The brake fluid level has dropped significantly.	You must stop as soon as it is safe to do so. Top up with brake fluid listed by CITROËN. If the problem persists, have the system checked by a CITROËN dealer or a qualified workshop.
+		fixed, associated with the ABS warning lamp.	The electronic brake force distribution (EBFD) system has a fault.	You must stop as soon as it is safe to do so. Have it checked by a CITROËN dealer or a qualified workshop.
	<b>Anti-lock Braking System (ABS)</b>	fixed.	The anti-lock braking system has a fault.	The vehicle retains conventional braking. Drive carefully at reduced speed and contact a CITROËN dealer or a qualified workshop without delay.
	<b>Dynamic stability control (DSC/ASR)</b>	flashing.	The DSC/ASR regulation is operating.	The system optimises traction and improves the directional stability of the vehicle in the event of loss of grip or trajectory.
		fixed.	The DSC/ASR system has a fault.	Have it checked by a CITROËN dealer or a qualified workshop.

Warning / indicator lamp		State	Cause	Action / Observations
	<b>Engine autodiagnosis system</b>	flashing.	The engine management system has a fault.	Risk of destruction of the catalytic converter. Have it checked by a CITROËN dealer or a qualified workshop.
		fixed.	The emission control system has a fault.	The warning lamp should go off when the engine is started. If it does not go off, contact a CITROËN dealer or qualified workshop without delay.
	<b>Low fuel level</b>	fixed with the two last bars flashing, accompanied by a message and an audible signal.	When it first comes on there remains <b>approximately 6 litres of fuel</b> in the tank.	<p>You must refuel as soon as possible to avoid running out of fuel.</p> <p>This warning lamp will come on every time the ignition is switched on, accompanied by a message and an audible signal, until a sufficient addition of fuel is made.</p> <p>This audible signal and message are repeated with increasing frequency as the fuel level drops and approaches "0".</p> <p>Fuel tank capacity: approximately 60 litres.</p> <p>Never continue to drive until you run out of fuel as this could damage the emission control and injection systems.</p>
 + <b>SERVICE</b>	<b>Under-inflation</b>	fixed.	The pressure in one or more wheels is too low.	Check the pressure of the tyres as soon as possible. This check should preferably be carried out when the tyres are cold.
		flashing then fixed, accompanied by the Service warning lamp.	The tyre pressure monitoring system has a fault or no sensor is detected on one of the wheels.	Under-inflation detection is not assured. Have the system checked by a CITROËN dealer or a qualified workshop.





Warning / indicator lamp		State	Cause	Action / Observations
	<b>AdBlue® additive (BlueHDi Diesel)</b>	fixed, on switching on the ignition, accompanied by an audible signal and a message indicating the remaining driving range.	The remaining driving range is between 350 miles (600 km) and 1500 miles (2400 km).	Have the AdBlue® additive tank topped up as soon as possible: go to a CITROËN dealer or a qualified workshop, or carry out this operation yourself.
		flashing associated with the SERVICE warning lamp, accompanied by an audible signal and a message indicating the remaining driving range.	The remaining driving range is between 0 and 350 miles (600 km).	You must <b>top-up the AdBlue®</b> additive tank to <b>avoid a breakdown</b> : go to a CITROËN dealer or a qualified workshop, or carry out this operation yourself.
		flashing, associated with the SERVICE warning lamp, accompanied by an audible signal and a message indicating that starting is prevented.	The AdBlue® tank is empty: the starting inhibition system required by legislation prevents starting of the engine.	To be able to start the engine, you must <b>top-up the AdBlue®</b> additive tank: go to a CITROËN dealer or a qualified workshop, or carry out this operation yourself. It is <b>essential</b> to add at least 3.8 litres of AdBlue® to the additive tank.

 For topping-up or for more information on the AdBlue® additive, refer to the corresponding section.

Warning / indicator lamp	State	Cause	Action / Observations
 <p>UREA + SERVICE + </p>	<p>fixed, on switching on the ignition, associated with the SERVICE and engine diagnostic warning lamps, accompanied by an audible signal and a message.</p>	<p>A fault with the SCR emissions control system has been detected.</p>	<p>This alert disappears once the exhaust emissions return to normal levels.</p>
	<p>flashing, on switching on the ignition, associated with the SERVICE and engine diagnostic warning lamps, accompanied by an audible signal and a message indicating the remaining driving range.</p>	<p>After confirmation of the fault with the emissions control system, you can drive for up to 650 miles (1 100 km) before the engine starting inhibition system is triggered.</p>	<p>Contact a CITROËN dealer or a qualified workshop <b>without delay, to avoid a breakdown.</b></p>
	<p>flashing, on switching on the ignition, associated with the SERVICE and engine diagnostic warning lamps, accompanied by an audible signal and a message.</p>	<p>You have exceeded the authorised driving limit following confirmation of a fault with the emissions control system: the engine starting inhibition system prevents starting of the engine.</p>	<p>To be able to start the engine, you <b>must</b> call on a CITROËN dealer or a qualified workshop.</p>





Warning / indicator lamp		State	Cause	Action / Observations
	<b>Seat belt(s) not fastened / unfastened</b>	fixed or flashing accompanied by an audible signal.	A seat belt has not been fastened or has been unfastened.	Pull the strap then insert the tongue in the buckle.
	<b>Airbags</b>	on temporarily.	This lamp comes on for a few seconds when you turn on the ignition, then goes off.	This lamp should go off when the engine is started. If it does not go off, contact a CITROËN dealer or a qualified workshop.
		fixed.	One of the airbag or seat belt pretensioner systems has a fault.	Have it checked by a CITROËN dealer or a qualified workshop.
	<b>Directional headlamps</b>	flashing.	The directional headlamps system has a fault.	Have it checked by a CITROËN dealer or a qualified workshop.

## Coolant temperature gauge

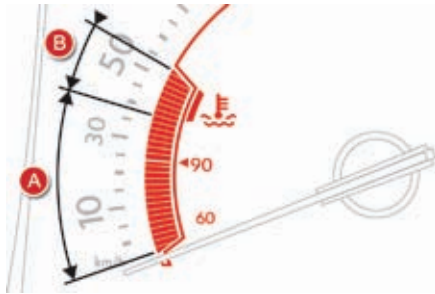

With the engine running:

- in zone **A**, the temperature is correct,
- in zone **B**, the temperature is too high; the central **STOP** warning lamp comes on, accompanied by an audible signal and a message in the instrument panel screen.

**You MUST stop as soon as it is safe to do so.**

Wait a few minutes before switching off the engine.

Contact a CITROËN dealer or a qualified workshop.

After driving for a few minutes, the temperature and pressure in the cooling system increase.

To top up the level:

- ☞ wait for the engine to cool,
- ☞ unscrew the cap by two turns to allow the pressure to drop,
- ☞ when the pressure has dropped, remove the cap,
- ☞ top up the level to the "MAX" mark.

 Be aware of the risk of burns when topping up the cooling system. Do not fill above the maximum level (indicated on the reservoir).

## Service indicator



System which informs the driver when the next service is due, in accordance with the manufacturer's service schedule.

The point at which the service is due is calculated from the last service indicator reset to zero, according to the mileage covered and the time elapsed since the last service.

**i** For BlueHDi Diesel versions, depending on the country of sale, the degree of deterioration of the engine oil may also be taken into account.

### More than 1 800 miles (3 000 km) remain before the next service is due

When the ignition is switched on, no service information appears in the instrument panel screen.

### Between 600 miles (1 000 km) and 1 800 miles (3 000 km) remain before the next service is due

For a few seconds after the ignition is switched on, the spanner symbolising the service operations comes on and a message is displayed in the instrument panel indicating the distance or time remaining before the next service is due.

**Example:** 1 900 miles (2 800 km) remain before the next service is due.

When the ignition is switched on, the instrument panel screen temporarily indicates:

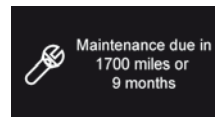

A few seconds after the ignition is switched on, **the spanner goes off.**



## Less than 600 miles (1 000 km) remain before the next service is due

**Example:** 500 miles (900 km) remain before the next service is due.

For a few seconds after the ignition is switched on, the instrument panel screen indicates:

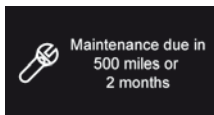

After the message disappears, **the spanner remains on** alongside the mileage recorder as a reminder that a service must be carried out soon.



## Service overdue

For a few seconds after the ignition is switched on, **the spanner flashes** to indicate that the service must be carried out as soon as possible.

**Example:** the service is overdue by 300 miles. When the ignition is switched on, the instrument panel screen indicates:

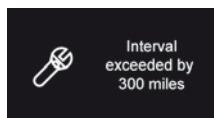

**The spanner remains on** alongside the mileage recorder to indicate that a service is overdue.

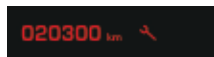

The spanner may come on if you have exceeded the period since the last service, as indicated in the manufacturer's service schedule.

 For BlueHDi Diesel versions, the spanner may also come on early, according to the level of deterioration of the engine oil, which depends on the driving conditions in which the vehicle is used.

 With BlueHDi Diesel versions, the **Service** warning lamp also comes on when the ignition is switched on.



## Resetting the service indicator



After each service, the service indicator must be reset to zero.

If you have carried out the service on your vehicle yourself:

- ☞ switch off the ignition,
- ☞ press and hold the trip distance recorder zero reset button,
- ☞ switch on the ignition; the distance recorder display begins a countdown,
- ☞ when the display indicates "**=0**", release the button; the spanner disappears.



If you have to disconnect the battery following this operation, lock the vehicle and wait at least five minutes for the reset to be registered.

## Retrieving the service information

You can access the service information at any time.

- ☞ Press the trip distance recorder zero reset button.

The service information is displayed for a few seconds, then disappears.

## Engine oil level indicator\*

On versions fitted with an electric oil level indicator, the state of the engine oil level is displayed in the instrument panel for a few seconds, after the servicing information.

 The level read will only be correct if the vehicle is on level ground and the engine has been off for more than 30 minutes.



### Oil level correct

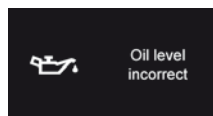

### Oil level incorrect

This is indicated by the display of the message "Oil level incorrect" in the instrument panel screen, accompanied by the service warning lamp and an audible signal.

If the low oil level is confirmed by a check using the dipstick, the level must be topped up to avoid damage to the engine.

For more information on checking the levels, refer to the corresponding section.



### Oil level indicator fault

This is signalled by the display of the message "Oil level measurement invalid" in the instrument panel. Contact a CITROËN dealer or a qualified workshop.

In the event of a fault with the electric indicator, the oil level is no longer monitored.

If the system is faulty, you must check the engine oil level using the manual dipstick located under the bonnet.

For more information on checking the levels, refer to the corresponding section.

\* Depending on version.

## Distance recorders

The total and trip distances are displayed for thirty seconds when the ignition is switched off, when the driver's door is opened and when the vehicle is locked or unlocked.



### Total distance recorder

It measures the total distance travelled by the vehicle since its first registration.

**i** When travelling abroad, you may have to change the units of distance: the display of road speed must be in the official units (miles or km) for the country. The change of units is done via the screen configuration menu, with the vehicle stationary.

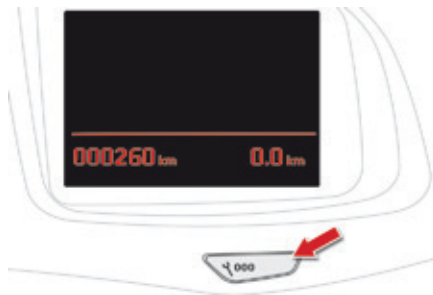

### Trip distance recorder

It measures the distance travelled since it was reset to zero by the driver.

- ☞ With the ignition on, press the button until zeros appear.

## Lighting dimmer

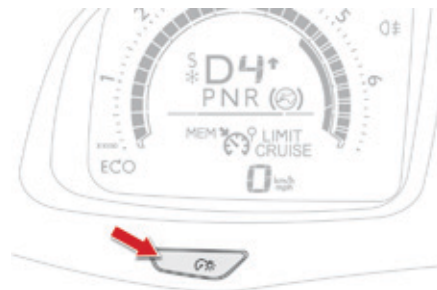

This allows manual adjustment of the brightness of the instruments and controls when driving at night.

When the lighting is on:

- ☞ press this button to adjust the brightness of the instruments and controls,
- ☞ when the level of brightness required is reached, release this button.

The setting is memorised when switching off the ignition.

**i** Pressing this button does not have any effect when the exterior lighting is off.

## Black panel (comfortable night display) with the touch screen

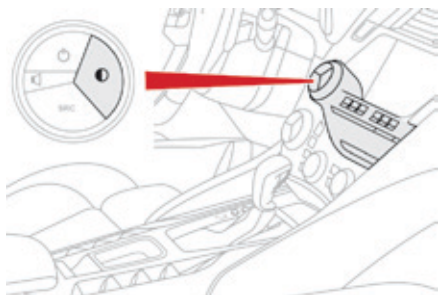

This allows some of the instrument panel displays, as well as the touch screen, to be switched off when driving at night, so as to reduce visual fatigue for the driver.

The essential driving information, such as the vehicle speed, warning lamps, the gear engaged for an automatic gearbox, cruise control or speed limiter, remains displayed in the instrument panel.



- ☞ With the exterior lighting on, press this button to activate the function.
- ☞ Press this button again or press the instrument panel lighting dimmer button to deactivate the function.

### Touch screen

You can return to the current display at any time by pressing the blank screen or one of the menu buttons.

-  In automatic illumination of headlamps mode, the "Black panel" function is automatically deactivated once the ambient light reaches an adequate level.

## Clock

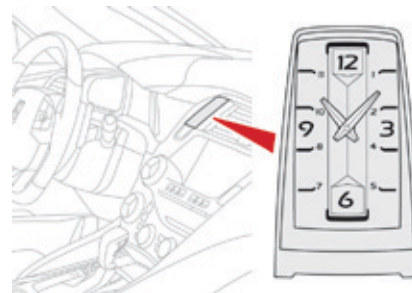

The analogue clock does not have an adjustment button. To set the time, refer to the section relating to the screen (audio system) configuration menu. The clock is synchronised with the screen time; once the the setting has been confirmed in the screen, the hands will turn to synchronise with the screen, as well as every time the ignition is switched on.



# Monochrome screen C

## Displays in the screen



Depending on the context, it displays:

- time,
- date,
- ambient temperature (this flashes if there is a risk of ice),
- visual parking sensor information,
- current audio source,
- telephone or Bluetooth system information,
- settings menus for the screen and the vehicle equipment.

## Controls

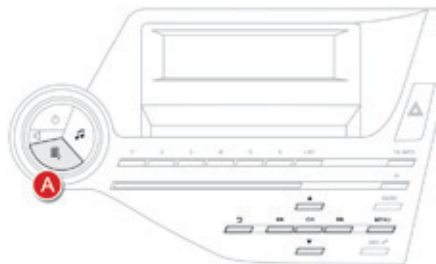

From the control panel of your Audio system, press:

- ☞ button **A** to chooses between the display of audio information in full screen or the shared display of the audio source and the time,
- ☞ the **"MENU"** button for access to the **main menu**,
- ☞ the **"▲"** or **"▼"** buttons to scroll through the items in the screen,
- ☞ the **"◀"** or **"▶"** buttons to change a setting value,
- ☞ the **"OK"** button to confirm,
- or
- ☞ the **"Back"** button to abandon the operation in progress.

## Main menu

### Personalisation-configuration



- ☞ Press the **"MENU"** button for access to the **main menu**:
  - "Multimedia",
  - "Telephone",
  - "Bluetooth connection",
  - "Personalisation-configuration",
- ☞ Press the **"◀"** or **"▶"** button to select the menu required, then confirm by pressing the **"OK"** button.



## "Multimedia" menu

With the audio system switched on, this menu allows you to activate or deactivate the functions associated with use of the radio (RDS, DAB / FM auto tracking, RadioText (TXT) display) or to choose the media play mode (Normal, Random, Random all, Repeat). For more information on the "Multimedia" application, see the "Audio and telematics" section.



## "Telephone" menu

With the audio system switched on, this menu allows you to make a call or view the various telephone directories. For more information on the "Telephone" application, see the "Audio and telematics" section.



## "Bluetooth connection" menu

With the audio system on, this menu allows a Bluetooth device (telephone, media player) to be connected or disconnected and the connection mode to be defined (hands-free, playing audio files). For more information on the "Bluetooth connection" application, see the "Audio and telematics" section.



## "Personalisation-configuration" menu



This menu gives access to the following functions:

- "Define the vehicle parameters",
- "Choice of language",
- "Display configuration",

### Define the vehicle parameters

This menu allows you to activate or deactivate the following equipment, classified in different categories:

- "Access to the vehicle" (see the "Access" section):
  - "Flip action" (Selective unlocking of the driver's door),
  - "Unlocking boot only" (Selective unlocking of the boot).

- "Driving assistance":
  - "Parking brake automatic" (Automatic electric parking brake; see the "Driving" section),
  - "Rear wiper in reverse gear" (Rear wiper coupled to reverse gear; see the "Visibility" section),
  - "Speeds memorised" (Memorising speeds; see the "Driving" section).
- "Vehicle lighting" (see the "Visibility" section):
  - "Directional headlamps" (Main / additional directional lighting),
- "Interior lighting" (see the "Visibility" section):
  - "Follow-me-home headlamps" (Automatic operation of headlamps after switching off the ignition),
  - "Welcome lighting" (Exterior welcome lighting),
  - "Mood lighting" (Mood lighting).

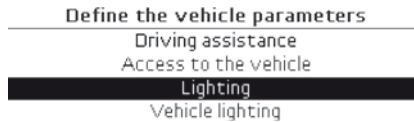

For example: setting of the duration of the "follow-me-home" lighting

- ☞ Press the "◀" or "▶" buttons, to select the "Define the vehicle parameters" menu, then the "OK" button.



OK

- ☞ Press the "▲" or "▼" buttons to select the "Interior lighting" line, then the "OK" button; then follow the same procedure to select the "Follow-me-home headlamps" line.

- ☞ Press the "◀" or "▶" buttons to set the value required (15, 30 or 60 seconds), then press the "OK" button to confirm.

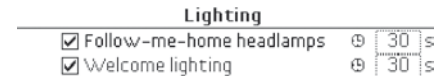

OK

- ☞ Press the "▲" or "▼" buttons, then the "OK" button to select the "OK" box and confirm or press the "Back" button to cancel.

## Choice of language

Once this menu has been selected, you can choose the language used by the display from a pre-defined list.

## Display configuration

This menu gives access to the following settings:

- "Choice of units",
- "Date and time adjustment",
- "Display parameters",
- "Brightness".

### Adjusting the date and time

- ☞ Press the "◀" or "▶" button to display the "Display configuration" menu, then press **"OK"**.
- ☞ Press the "▲" or "▼" button to select the "Date and time adjustment" button, then press **"OK"**.
- ☞ Press the "◀" or "▶" button to select the setting to modify. Confirm by pressing **"OK"**, then modify the setting and confirm again to save the modification.
- ☞ Adjust the settings one by one, confirming with the **"OK"** button.
- ☞ Press the "▲" or "▼" button, then the **"OK"** button to select the **"OK"** box and confirm or the **"Back"** button to cancel.

 The analogue clock, located in the dashboard, is synchronised with the time in the screen. It is set after the time is adjusted using the configuration menu and every time the ignition is switched on.

 As a safety measure, configuration of the multifunction screen by the driver must only be done when stationary.

# Touch screen

Associated with the navigation system, this screen gives access to:

- menus for adjusting settings for vehicle functions and systems,
- audio and display settings menus,
- audio system and telephone controls and the display of associated information.
- the controls for the navigation system and Internet services and the display of associated information.

It also allows the display of:

- the ambient temperature (a blue snowflake appears if there is a risk of ice),
- the trip computer,
- visual parking sensor information,
- the image from the reversing camera.

 For versions equipped with a navigation system in the touch screen, refer to the supplement in the handbook pack.

## General operation

### Recommendations

Its use is possible at all temperatures and when wearing gloves.

Do not use pointed objects on the touch screen.

Do not touch the touch screen with wet hands.

Uses a soft clean cloth to clean the touch screen.

 **As a safety measure, the driver should only carry out operations that require close attention with the vehicle stationary.**

Some functions are not accessible when driving.

### Principles

Press the virtual buttons in the touch screen. Each menu is displayed over one or two pages (primary page and secondary page).

Use the "**Options**" button to go to the secondary page.

 After a few moments with no action on the secondary page, the primary page is displayed automatically.



Use this button for access to additional information and to the settings for certain functions.



Use this button to confirm.



Use this button to quit the current display and return to the primary page.

## Menus

Press one of the buttons on the control panel for direct access to a particular menu.

### DRIVE Driving

Allows settings to be adjusted for certain vehicle functions.  
See the corresponding section.

### NAV Navigation.

See the "Audio and telematics" section.

### MEDIA Radio Media.

See the "Audio and telematics" section.

### TEL Telephone.

See the "Audio and telematics" section.

### WEB Connected services.

The connected services are accessible via Bluetooth, Wi-Fi, MirrorLink™ or CarPlay® connections.  
See the "Audio and telematics" section.



### SETUP Settings.



Allows configuration of the display and the system.  
Language, units, date and time, colour schemes, ...

1. Volume.
2. On / Off.
3. Black panel (comfortable night driving display).
4. Change audio source.
5. Access to audio settings.  
See the "Audio and telematics" section.



## "Driving" menu

The systems with settings that can be adjusted are detailed in the table below.

Button	Corresponding function	Comments
	<b>Speed settings</b>	Memorisation of speeds for use with the speed limiter or cruise control.
	<b>Vehicle settings</b>	Access to other functions with settings that can be adjusted: <ul style="list-style-type: none"><li>- Automatic parking brake (Automatic electric parking brake; see the "Driving" section),</li><li>- Automatic rear wiper in reverse (Activation of rear wiper coupled to reverse gear; see the "Visibility" section).</li><li>- Guide-me-home lighting (Automatic guide me home lighting; see the "Visibility" section),</li><li>- Welcome lighting (Exterior welcome lighting; see the "Visibility" section),</li><li>- Mood lighting (Mood lighting; see the "Visibility" section),</li><li>- Adaptive lighting (Main / additional directional lighting; see the "Visibility" section).</li><li>- Driver plip action (Selective unlocking of the driver's door; see the "Access" section),</li><li>- Unlocking boot (Selective unlocking of the boot; see the "Access" section).</li></ul>
<b>ECO OFF</b>	<b>Stop &amp; Start</b>	Deactivation of the function. Function deactivated = indicator lamp on (orange).

# Trip computer

System that gives you information on the current journey (range, fuel consumption...).

## Instrument panel screen

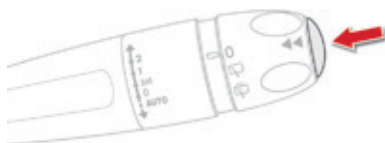

## Information display

☞ Press the button on the end of the **wiper control stalk** to display the various tabs in succession.



- The current information tab with:
  - the range,
  - the current fuel consumption,
  - the Stop & Start time counter.



- Trip "1" with:
  - the average speed,
  - the average fuel consumption for the first trip.



- Trip "2" with:
  - the average speed,
  - the average fuel consumption for the second trip.

- Radio or media.
- Satellite navigation.

## Trip reset

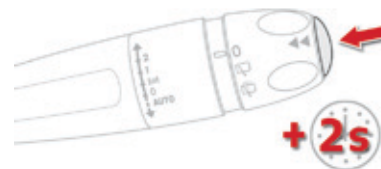

☞ When the desired trip is displayed, press for more than two seconds on the end of the **wiper control stalk**.

Trips "1" and "2" are independent but their use is identical.

For example, trip "1" can be used for daily figures, and trip "2" for monthly figures.





## Touch screen

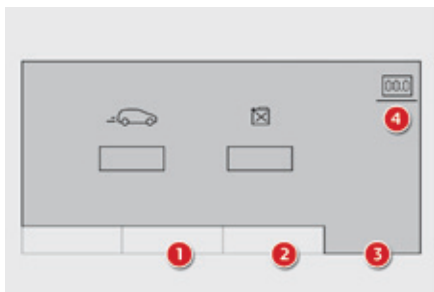

1. "Instantaneous".
2. "Trip 1".
3. "Trip 2".
4. "00.0 / Reset".

## Display of information



☞ Select the "Driving" menu.

The trip computer information is displayed in the primary page of the menu.

☞ Press one of the buttons to display the desired tab.

The current instantaneous fuel consumption tab with:

- the range,
- the current fuel consumption,
- the Stop & Start time counter.

The trip "1" tab with:

- the average speed,
- the average fuel consumption, for the first trip.

The trip "2" tab with:

- the average speed,
- the average fuel consumption, for the second trip.

## Trip reset

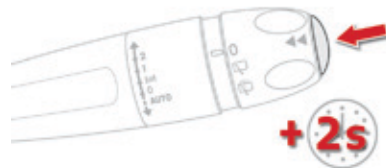

☞ When the desired trip is displayed, press the reset button or press and hold the end of the wiper control stalk.

Trips "1" and "2" are independent but their use is identical.

For example, trip "1" can be used for daily figures, and trip "2" for monthly figures.

## Trip computer, a few definitions...



### Range

(miles or km)

This indicates the distance which can still be travelled with the fuel remaining in the tank in relation to the average fuel consumption over the last few miles (kilometres) travelled.

**i** This value may vary following a change in the style of driving or the relief, resulting in a significant change in the current fuel consumption.

When the range falls below 20 miles (30 km), dashes are displayed. After filling with at least 5 litres of fuel, the range is recalculated and is displayed when it exceeds 60 miles (100 km).

**i** If dashes are displayed continuously while driving in place of the digits, contact a CITROËN dealer or a qualified workshop.



### Current fuel consumption

(mpg or l/100 km or km/l)

This is the average fuel consumption during the last few seconds.

**i** This function is only displayed from 20 mph (30 km/h).



### Average fuel consumption

(mpg or l/100 km or km/l)

This is the average fuel consumption since the last trip computer zero reset.



### Average speed

(mph or km/h)

This is the average speed calculated since the last trip computer zero reset (ignition on).



### Stop & Start time counter

(minutes / seconds or hours / minutes)

If your vehicle is fitted with Stop & Start, a time counter calculates the time spent in STOP mode during a journey. It resets to zero every time the ignition is switched on.



**002**

Access



# Electronic key remote control

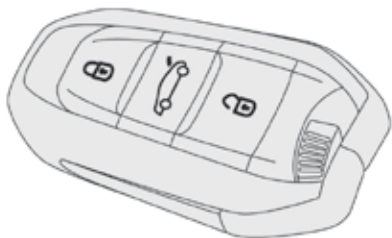

System which permits central unlocking or locking of the vehicle using the lock or from a distance. It is also used to locate and start the vehicle, as well as providing protection against theft.

## Unlocking the vehicle

### Complete unlocking



- ☞ Press the open padlock to completely unlock the vehicle.

### Selective unlocking



- ☞ To unlock only the driver's door, press the open padlock once.
- ☞ To unlock the other doors and the boot, press the open padlock again.



This setting is done in the vehicle configuration menu. Complete unlocking is activated by default.



Unlocking is confirmed by rapid flashing of the direction indicators for around two seconds.  
At the same time, depending on version, the door mirrors unfold.



## Selective boot unlocking



- ☞ Press this button until you hear the boot unlock. The doors remain locked.

 If selective boot unlocking is deactivated, pressing this button unlocks the whole vehicle.



The selective boot unlocking function is set in the vehicle configuration menu.

By default, selective boot unlocking is on.

## Locking the vehicle



- ☞ Press the closed padlock to fully lock the vehicle.
- ☞ Hold the button down until the windows close completely.

 Locking is confirmed by fixed illumination of the direction indicators for approximately two seconds. Depending on version, the door mirrors fold at the same time.

 Be particularly aware of children when operating the windows.

 If one of the doors or the boot is not fully closed, locking does not take place. When the vehicle is locked, if it is unlocked inadvertently, it will automatically lock itself again after about thirty seconds unless a door is opened. If the alarm was previously activated, it will not be reactivated automatically.

# Keyless Entry and Starting

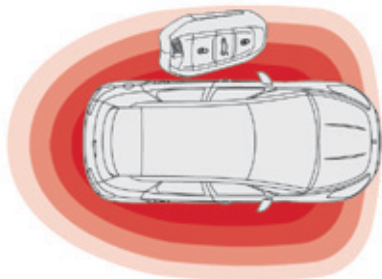

System that allows the unlocking, locking and starting of the vehicle while keeping the electronic key on your person.

**i** It can also be used as a remote control. For more information, refer to the "Electronic key / remote control" section.

**H** For reasons of safety and theft protection, do not leave your electronic key in the vehicle, even when you are close to it. It is recommended that you keep it on your person.

## Unlocking the vehicle

### Complete unlocking

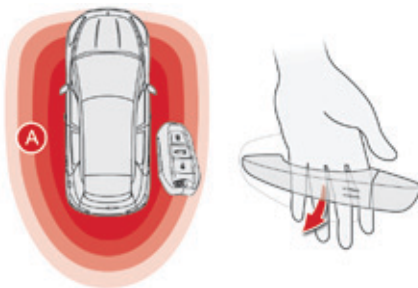

**H** With the electronic key on your person and in the recognition zone **A**, pass your hand behind one of the door handles to unlock the vehicle.

Your passengers can also open their doors, as soon as the electronic key is in the recognition zone.

### Selective unlocking

- H** To unlock only the drivers door, with the electronic key on your person, pass your hand behind the driver's door handle.
- H** To unlock the complete vehicle, pass your hand behind one of the passenger door handles on the same side of the vehicle as the electronic key is located.



This setting is done via the vehicle configuration menu.

By default, complete unlocking is activated.

**i** Unlocking is confirmed by rapid flashing of the direction indicators for approximately two seconds. The door mirrors unfold at the same time. If the alarm is on, the audible warning triggered when opening a door with the key (integral with the remote control), will stop when the ignition is switched on.



## Locking the vehicle

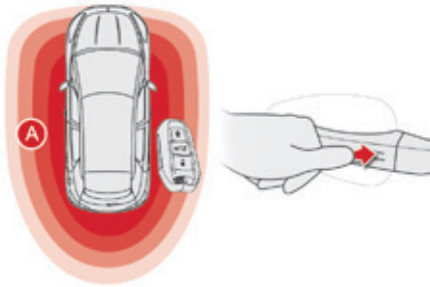

- ☞ With the electronic key on your person in the recognition zone **A**, press with a finger or thumb on one of the door handles (at the markings) to lock the vehicle.
- ☞ Maintain pressure with your finger or thumb until the windows close completely.

**i** Locking is confirmed by fixed lighting of the direction indicators for approximately two seconds. The door mirrors fold at the same time.

**!** Ensure that nothing and no person prevents the correct operation of the windows. Be particularly aware of children when operating the windows.

**i** If one of the doors or the boot is still open or if the key for Keyless Entry and Starting system has been left inside the vehicle or if the ignition is on, the central locking does not take place. When the vehicle is locked, if it is unlocked inadvertently, it will lock itself again automatically after about thirty seconds unless a door is opened. If the alarm was previously activated, it will not be reactivated automatically. The folding and unfolding of the door mirrors by the remote control can be deactivated by a CITROËN dealer or a qualified workshop.

## Locating your vehicle



This function allows you to identify your vehicle from a distance, particularly in poor light. Your vehicle must be locked.

- ☞ Press the closed padlock on the remote control.

This will switch on the courtesy lamps and the direction indicators will flash for around ten seconds.

**!** As a safety measure (children on board), never leave the vehicle without taking the key for the Keyless Entry and Starting system, even for a short period. Guard against theft when the key for the Keyless Entry and Starting system is in the recognition zone with the vehicle unlocked.

In order to preserve the charge of the cell battery in the remote control, the "hands-free" functions go into extended stand-by after 21 days of non-use. To restore these functions, press one of the remote control buttons or start the engine with the electronic key in the reader.

## Deadlocking

- ⚠ Deadlocking renders the exterior and interior door controls inoperative. It also deactivates the manual central locking button. You must therefore never leave anyone inside the vehicle when it is deadlocked.

### Using the remote control



- ☞ Press the closed padlock to lock the vehicle completely. Maintain pressure with your finger to close the windows.

- ☞ Press the closed padlock again within five seconds to deadlock the vehicle.



- ⚠ Ensure that nothing or any person prevents the correct closing of the windows. Be particularly aware of children when operating the windows.

### With Keyless Entry and Starting

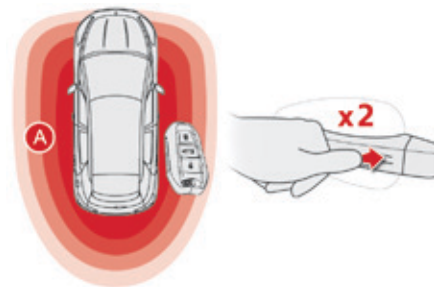

By the doors:

- ☞ With the electronic key on your person in the recognition zone **A**, press with a finger or thumb on the door handle (at the markings) to lock the vehicle.
- ☞ Within five seconds, press the door handle again to deadlock the vehicle.

## Back-up key

### Unlocking / Locking using the integral key with Keyless Entry and Starting

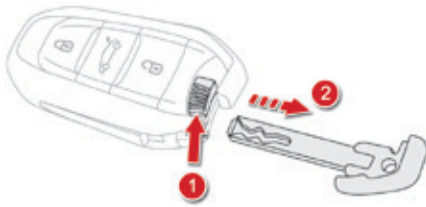

The integral key is used to lock and unlock the vehicle when the electronic key cannot operate:

- cell battery flat, vehicle battery discharged or disconnected, ...
  - vehicle located in an area with strong electromagnetic signals.
- ☞ Maintain a pull on button 1, to extract the integral key 2.

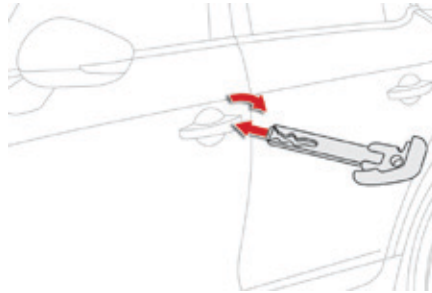

#### Locking the driver's door

- ☞ Insert the integral key in the door lock, then turn it to the rear.

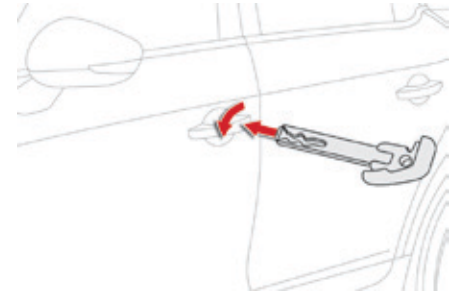

#### Unlocking the driver's door

- ☞ Insert the integral key in the door lock, then turn it to the front.

**i** If the alarm is activated, the audible signal triggered on opening a door with the key (integral with the remote control) will stop when the ignition is switched on.

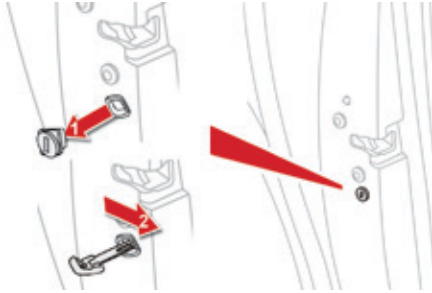

### Locking the passenger doors

- ☞ Open the doors.
- ☞ On the rear doors, check that the child lock is not on.

For more information on the child lock, refer to the corresponding section.

- ☞ Remove the black cap, located on the edge of the door, using the integral key.
- ☞ Insert the integral key in the socket without forcing it, then without turning it, move the latch sideways towards the inside of the door.
- ☞ Remove the integral key and refit the cap.
- ☞ Close the doors and check that the vehicle has locked correctly from the outside.

### Unlocking the passenger doors

- ☞ Pull the interior door opening control.

## Remote control problem - reinitialisation

Following disconnection of the vehicle battery, replacement of the remote control battery or in the event of a remote control malfunction, you can no longer unlock, lock or locate your vehicle.

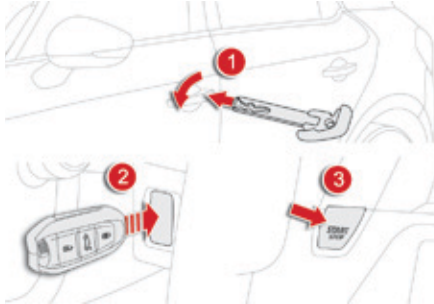

- ☞ Place the mechanical key (integral with the remote control) in the lock to unlock your vehicle.
- ☞ Place the electronic key in the reader.
- ☞ Switch on the ignition by pressing START/STOP.

The electronic key is fully operational again. If the problem persists, contact a CITROËN dealer or a qualified workshop as soon as possible.

## Changing the cell battery

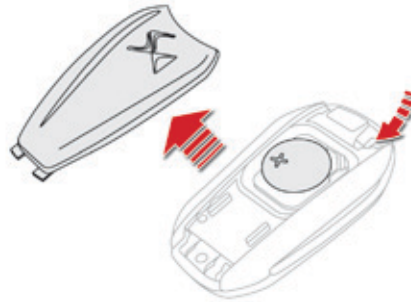

Battery ref.: CR2032 / 3 volts.

This replacement battery is available from a CITROËN dealer or a qualified workshop. A message appears in the instrument panel screen when replacement of the battery is needed.

- ☞ Unclip the cover using a small screwdriver at the cutout.
- ☞ Lift off the cover.
- ☞ Remove the flat battery from its location.
- ☞ Fit the new battery into its location observing the original direction of fitment.
- ☞ Clip the cover onto the casing.



Do not throw the remote control batteries away, they contain metals which are harmful to the environment. Take them to an approved collection point.



## **Lost electronic key**

Visit a CITROËN dealer with the vehicle's registration certificate, your personal identification documents and if possible the key code label. The CITROËN dealer will be able to retrieve the key code and the transponder code required to order a new key.

## **Electronic key**

The electronic key is a sensitive system; do not operate it while it is in your pocket as there is a possibility that it may unlock the vehicle, without you being aware of it.

Do not repeatedly press the buttons of your electronic key out of range and out of sight of your vehicle. You run the risk of stopping it from working and the remote control would have to be reinitialised.

The electronic key cannot operate as a remote control when it is in the reader or even when the ignition is switched on.

## **Locking the vehicle**

Driving with the doors locked may make access to the passenger compartment by the emergency services more difficult in an emergency. As a safety precaution (with children on board), take the electronic key with you when you leave the vehicle, even for a short time.

## **Electrical interference**

The electronic key may not operate if close to certain electronic devices: telephone, laptop computer, strong magnetic fields, ...

## **Anti-theft protection**

Do not make any modifications to the electronic engine immobiliser system; this could cause malfunctions.

## **When purchasing a second-hand vehicle**

Have all of the keys in your possession paired by a CITROËN dealer, to ensure that only your keys allow your vehicle to be unlocked and started.

# Central locking

## Manual central locking

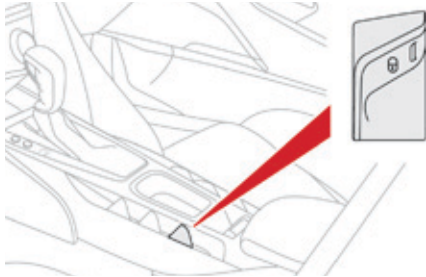

- ☞ Press this button to operate the central locking of the vehicle (doors and boot) from inside the vehicle.
- ☞ Pressing the button again unlocks the vehicle completely.

### When locking / deadlocking from the outside

If the vehicle is locked or deadlocked from the outside, the button is not active.

- ☞ After normal locking, pull one of the interior door handles to unlock the vehicle.
- ☞ After deadlocking, you have to use the remote control, the Keyless Entry and Starting system or the integral key to unlock the vehicle.

## Automatic central locking of doors (anti-intrusion security)

The doors and boot lock automatically when driving, as soon as the speed exceeds 6 mph (10 km/h).

To activate or deactivate this function (activated by default):



- ☞ with the ignition on, press this button until a message appears in the instrument panel.



If one of the doors or the boot is open, automatic central locking does not complete: the sound of the locks rebounding can be heard.



### Transporting long or voluminous objects

If you want to drive with the boot open but the vehicle's side doors locked, press the central locking control button to lock the doors.



Driving with the doors locked may make access to the passenger compartment by the emergency services more difficult in an emergency.

# Boot

## Opening from outside

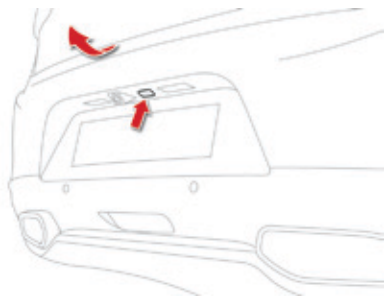

- ☞ After unlocking the boot only or the vehicle, press the opening control then raise the tailgate.

## Opening from inside

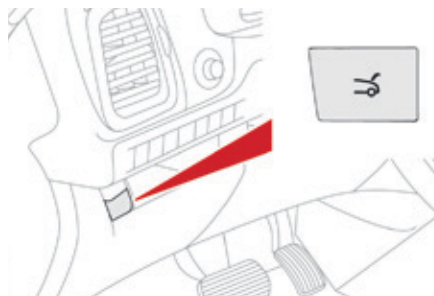

- ☞ Press this button until the boot is heard to unlock.

## Closing

- ☞ Lower the tailgate using the interior grab handle.

If the tailgate is not closed correctly, **engine running** or **vehicle moving** (speed above 6 mph (10 km/h)), a message appears in the instrument panel screen for a few seconds.

## Tailgate release

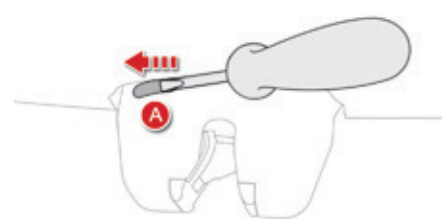

System allowing the mechanical unlocking of the boot in the event of a battery or central locking system malfunction.

## Unlocking

- ☞ Fold back the rear seats to gain access to the lock from inside the boot.
- ☞ Insert a small screwdriver into hole **A** of the lock to unlock the tailgate.
- ☞ Move the latch to the left.

## Locking after closing

If the fault persists after closing again, the boot will remain locked.



# Alarm

System which protects and provides a deterrent against theft and break-in. It provides the following types of monitoring:

## - Exterior perimeter

The system checks for opening of the vehicle. The alarm is triggered if anyone tries to open a door, the boot or the bonnet...

## - Interior volumetric

The system checks for any variation in the volume in the passenger compartment. The alarm is triggered if anyone breaks a window, enters the passenger compartment or moves inside the vehicle.

## - Tilt

The system checks for any change in the attitude of the vehicle. The alarm is triggered if the vehicle is lifted, moved or knocked.

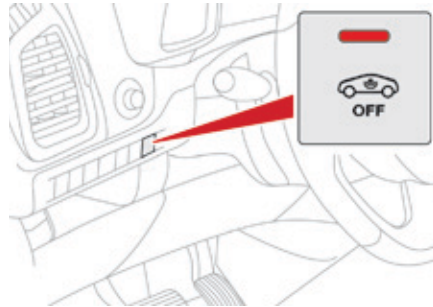



## Self-protection function

The system checks for the putting out of service of its components. The alarm is triggered if the battery, the button or the wires of the siren are put out of service or damaged.

For all work on the alarm system, contact a CITROËN dealer or a qualified workshop.

## Locking the vehicle with full alarm system

### Activation

-  Switch off the ignition and get out of the vehicle.
-   Press the locking button on the remote control or lock the vehicle using the Keyless Entry and Starting system.

The monitoring system is active: the indicator lamp in the button flashes once per second.

-  Following an instruction to lock the vehicle from the remote control or using the Keyless Entry and Starting system, the exterior perimeter monitoring is activated after a delay of 5 seconds, the interior volumetric monitoring after 45 seconds and the anti-tilt after 90 seconds. If an opening (door, boot...) is not closed fully, the vehicle is not locked but the exterior perimeter monitoring will be activated after a delay of 45 seconds.

## Deactivation



☞ Press the unlocking button on the remote control or unlock the vehicle using the Keyless Entry and Starting system.



The alarm system is deactivated: the indicator lamp in the button goes off.



Where the vehicle locks itself again automatically (occurs 30 seconds after unlocking, if a door or the boot is not opened), the monitoring system is not reactivated automatically.

To reactivate it, the vehicle must be unlocked and locked again, using the remote control or the "Keyless Entry and Starting" system.

## Locking the vehicle with exterior perimeter monitoring only

Deactivate the interior volumetric and anti-lift monitoring to avoid unwanted triggering of the alarm in certain cases such as:

- leaving a window partially open,
- leaving a pet in the vehicle,
- washing your vehicle,
- changing a wheel,
- having your vehicle towed,
- transportation by sea.

## Deactivation of the interior volumetric and anti-tilt monitoring



☞ Switch of the ignition and within ten seconds, press this button until the indicator lamp is on continuously.

☞ Get out of the vehicle.



☞ Press the locking button on the remote control immediately or lock the vehicle using the Keyless Entry and Starting system.

The exterior perimeter monitoring alone is activated: the indicator lamp in the button flashes once per second.



To be effective, this deactivation must be carried out each time the ignition is switched off.



## Reactivation of the interior volumetric and anti-tilt monitoring



☞ Press the unlocking button on the remote control or unlock the vehicle using the Keyless Entry and Starting system to deactivate the exterior perimeter monitoring.



☞ Press the locking button on the remote control or lock the vehicle using the Keyless Entry and Starting system to activate all the monitoring functions.



The indicator lamp in the button again flashes once per second.

## Triggering of the alarm

This is indicated by sounding of the siren and flashing of the direction indicators for thirty seconds.

The monitoring functions remain active until the alarm has been triggered eleven times in succession.



When the vehicle is unlocked using the remote control or unlocked using the Keyless Entry and Starting system, rapid flashing of the indicator lamp in the button informs you that the alarm was triggered during your absence. When the ignition is switched on, this flashing stops immediately.

## Failure of the remote control

In this case, carry out the operations below to deactivate the monitoring functions:

- ☞ Unlock the vehicle using the key (integral with the remote control) in the driver's door lock.
- ☞ Open the door; the alarm is triggered.
- ☞ Switch on the ignition; the alarm stops. The indicator lamp in the button goes off.

## Locking the vehicle without activating the alarm

- ☞ Lock or deadlock the vehicle using the key (integral with the remote control) in the driver's door lock.

## Operating fault

When the ignition is switched on, fixed illumination of the indicator lamp in the button indicates a fault in the system. Have it checked by a CITROËN dealer or a qualified workshop.

## Automatic activation\*

2 minutes after the last door or the boot is closed, the system is activated automatically.

- ☞ To avoid triggering the alarm on entering the vehicle, first press the unlocking button on the remote control or unlock the vehicle using the Keyless Entry and Starting system.

\* Depending on the country of sale.

# Electric windows

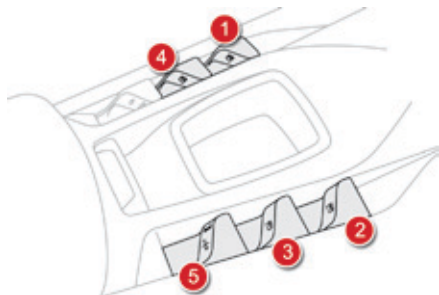

1. Left hand front electric window switch.
2. Right hand front electric window switch.
3. Right hand rear electric window switch.



4. Left hand rear electric window switch.
5. Deactivating the rear electric window switches, locking the rear doors (child lock).

## Operation

### Manual mode

To open or close the window, press or pull the switch gently. The window stops as soon as the switch is released.

### Automatic mode

To open or close the window, press or pull switch fully: the window opens or closes completely when the switch is released. Pressing or pulling the switch again stops the movement of the window.

**i** The electric window switches remain operational for approximately 45 seconds after switching off the ignition, while the vehicle's doors are still closed. Once a door is opened, or once the 45 seconds have elapsed, you have to switch on the ignition to operate the windows.



## Safety anti-pinch

When the window rises and meets an obstacle, it stops and immediately partially lowers again. In the event of unwanted opening of the window on closing, press the switch until the window opens completely, then pull the switch immediately until the window closes. Continue to hold the switch for approximately one second after the window has closed.

The safety anti-pinch function is not active during this operation.

## Deactivating the rear window controls



For the safety of your children, press switch **5** to prevent operation of the rear windows irrespective of their position.

The warning lamp in the button comes on, accompanied by a message confirming activation. It remains on, as long as the child lock is activated.

The interior controls for the rear doors are also deactivated.

Opening the doors from the outside and operation of the rear windows from the driver's controls remain possible.

## Reinitialisation of the electric windows

Following reconnection of the battery, the safety anti-pinch function must be reinitialised. The safety anti-pinch function is not active during these operations.

For each window:

- lower the window completely, then raise it. It will rise in steps of a few centimetres each time the switch is pressed. Repeat the operation until the window closes completely,
- continue to press the switch for at least one second after reaching this position, window closed.



In the event of contact during operation of the windows, you must reverse the movement of the window. To do this, press the switch concerned.

When operating the passenger electric window switches, the driver must ensure that no one is preventing correct closing of the windows.

The driver must ensure that the passengers use the electric windows correctly.

Be particularly aware of children when operating the windows.

Be aware of passengers and other persons present close to the vehicle when closing the windows remotely using the the electronic key or the Keyless Entry and Starting system.

# Cockpit glass roof

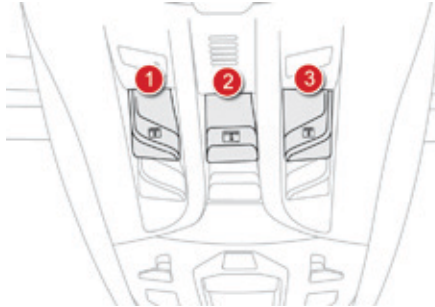

Each of the three sections of the glass roof is fitted with an electric blind. The controls for the blinds can be operated individually or simultaneously.

## Electric blinds

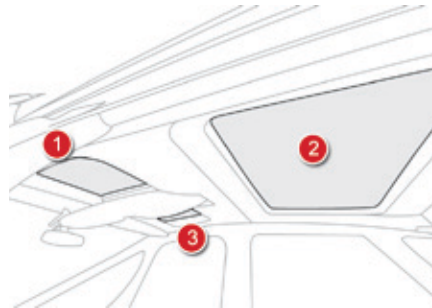

There are two options for opening and closing:

### Manual mode

- ☞ Pull or press the control switch without going beyond the point of resistance (forwards to close and rearwards to open). When you release the control switch, the blind continues to move for a further 2 cm approximately, then stops.

### Automatic mode

- ☞ Pull or press the control switch, going beyond the point of resistance (forwards to close and rearwards to open). One press opens or closes the blind completely. Following a new action on the the control switch, the blind continues to move for a further 2 cm approximately, then stops.

### Safety anti-pinch

In automatic mode and at the end of its travel, if the blind meets an obstacle while closing, it stops and moves back slightly.



## Reinitialisation

In the event of a failure or battery disconnection while a blind is moving or soon after it stops, the safety anti-pinch must be reinitialised.

For each blind control switch:

- ☞ operate the control until the blind is fully closed,
- ☞ continue to press for at least 3 seconds. A slight movement of the blind will then be noticeable, confirming the reinitialisation.



If the blind opens again on its own during a closing movement or soon after stopping:

- ☞ operate the control switch until the blind is fully open,
- ☞ then operate the control switch until the blind is fully closed.

**The safety anti-pinch function is not operational during these operations.**



If the blind meets an obstacle during operation, you must reverse the movement of the blind. To do this, press the control switch for the blind in question.

When the driver operates the blind control switch, they must ensure that no one is preventing correct closing of the blind.

The driver must ensure that passengers use the blind correctly.

Be particularly aware of children when operating the blind.

**003**

Comfort





# Front seats

## Manual

### 1. Adjustments to the height and angle of the head restraint

To raise it, pull upwards.

To lower it, press on the lug and the head restraint at the same time.

### 2. Adjustment of the backrest angle

Turn the wheel to adjust the angle of the backrest.

### 3. Adjustment of the seat height

Raise or lower the control lever the number of times required to obtain the desired position.

### 4. Forwards-backwards adjustment of the seat position

Lift the control bar and slide the seat forwards or backwards.

### 5. Adjustment of the driver's lumbar support

Turn the wheel to obtain the desired level of lumbar support.

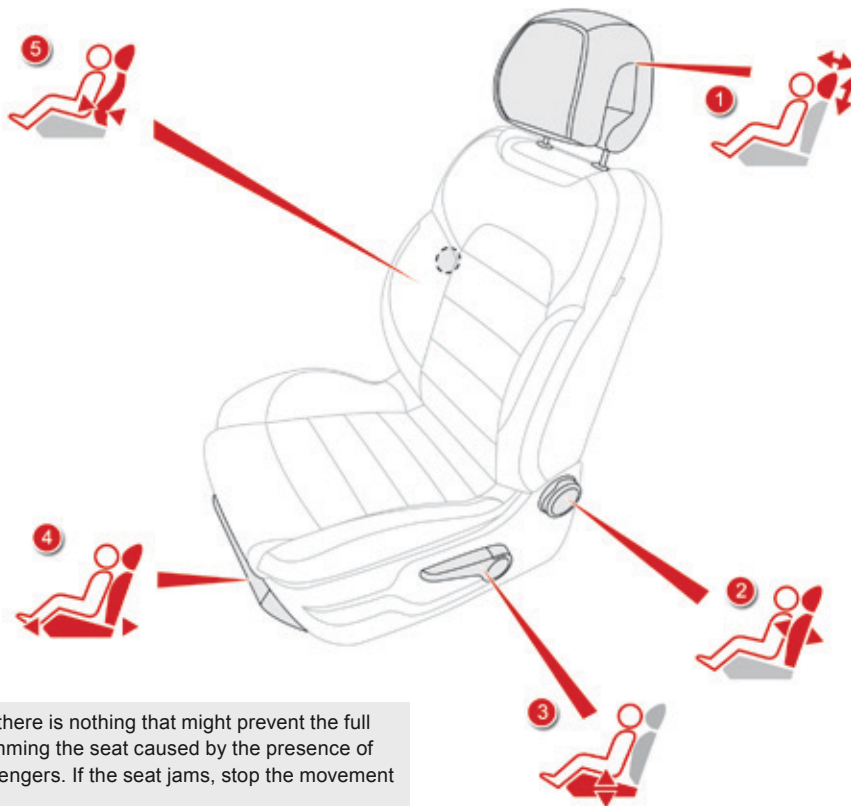

Before moving the seat backwards, ensure that there is nothing that might prevent the full travel of the seat, so as to avoid the risk of jamming the seat caused by the presence of objects on the floor behind the seat or rear passengers. If the seat jams, stop the movement immediately.

## Electric

### 1. Adjustment of the seat cushion angle and height, and forwards-backwards adjustment

- ☞ Raise or lower the front of the control to adjust the seat cushion angle.
- ☞ Raise or lower the rear of the control to raise or lower the seat.
- ☞ Simultaneously raise or lower the front and rear of the control in order to raise or lower the entire seat.

### 2. Adjustment of the backrest angle

Move the control forwards or backwards to adjust the backrest angle.

### 3. Adjustment of driver's lumbar support

Press the control switches to obtain the desired level of lumbar support.

### 4. Manual adjustment of the cushion

Pull on the grip to adjust the length of the cushion.

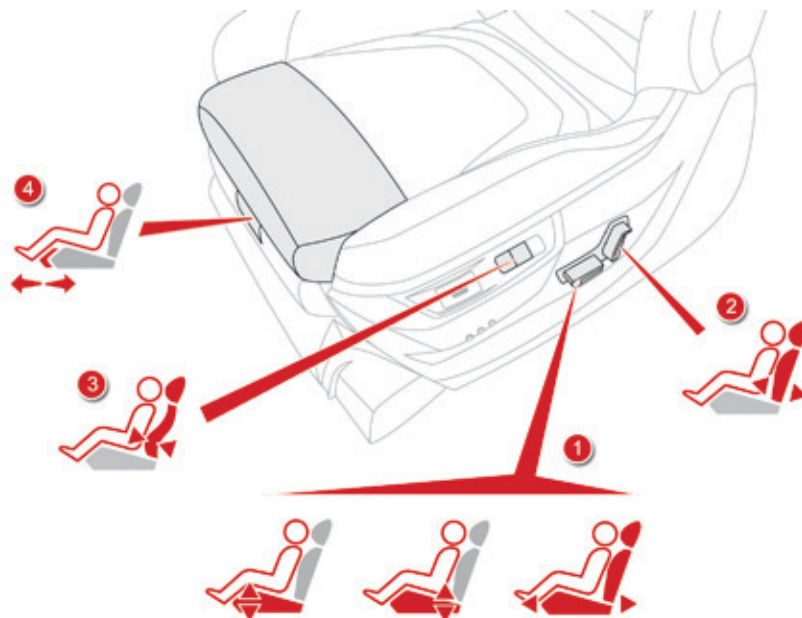

**i** Switch on the ignition or start the engine if the vehicle has gone into economy mode.  
The electric functions of the driver's seat are active for about 45 seconds after opening the front door. They are deactivated about 45 seconds after switching off the ignition and in economy mode.  
To reactivate them, switch on the ignition.

**w** Before moving the seat backwards, ensure that there is nothing that might prevent the full travel of the seat, so as to avoid the risk of jamming the seat caused by the presence of objects on the floor behind the seat or rear passengers.  
If the seat jams, stop the movement immediately.

## Storing driving positions

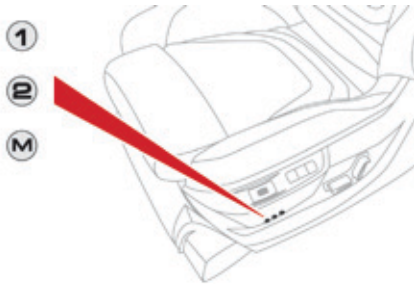

System which stores the electrical settings of the driver's seat and the head-up display settings. It enables you to store up to two positions using the buttons on the side of the driver's seat.

### Storing a position using buttons M / 1 / 2

- ☞ Switch on the ignition.
- ☞ Adjust your seat and the head-up display.
- ☞ Press button **M**, then press button **1** or **2** within four seconds.  
An audible signal indicates that the position has been stored.

Storing a new position cancels the previous position.

### Recalling a stored position

- ☞ Briefly press button **1** or **2** to recall the corresponding position.  
An audible signal indicates the end of the adjustment.

**i** You can interrupt the current movement by pressing button **M**, **1** or **2** or by using one of the seat controls.  
A stored position cannot be recalled while driving.  
Recalling stored positions is deactivated 45 seconds after switching off the ignition.

## Head restraint height and angle adjustment

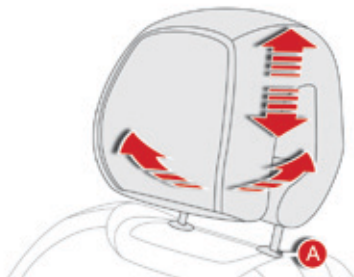

- ☞ To raise a head restraint, pull it upwards.
- ☞ To remove the head restraint, press the lug **A** and pull the head restraint upwards.
- ☞ To put the head restraint back in place, engage the head restraint stems in the openings keeping them in line with the seat back.
- ☞ To lower the head restraint, press the lug **A** and push down on the head restraint at the same time.
- ☞ To adjust the angle of the head restraint, tilt its lower part forwards or rearwards.

 The head restraint is fitted with a frame with notches which prevents it from lowering; this is a safety device in case of impact.

**The adjustment is correct when the upper edge of the head restraint is level with the top of the head.**

Never drive with the head restraints removed; they must be in place and adjusted correctly.

## Heated seats control

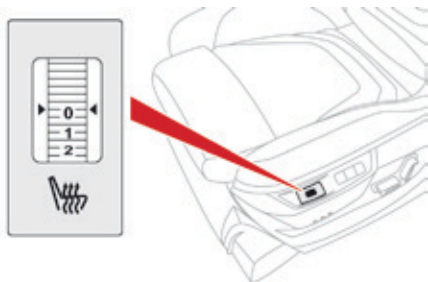

☞ Use the adjustment wheel to switch on and select the level of heating required:

- 0: Off.
- 1: Low.
- 2: Medium.
- 3: High.

With the engine running, the front seats can be heated separately.

## Massage function

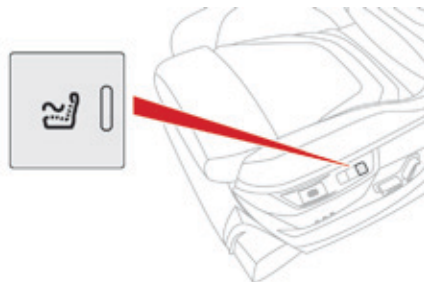

This system provides a back massage. It only operates when the engine is running or in STOP mode of the Stop & Start system.

### Activation



☞ Press this switch.

Its indicator lamp comes on and the massage function is activated for a period of 1 hour. During this time, massage is performed in 6 cycles of 10 minutes (6 minutes of massage followed by 4 minutes break). After one hour, the function is deactivated, the indicator lamp goes off.

### Deactivation



You can deactivate the massage function at any time by pressing this switch, its indicator lamp goes off.

## Rear seats

Bench seat with split cushion and backrest (left hand 2/3, right hand 1/3) which can be folded individually to adapt the load space in the boot.

### Folding the cushion and backrest

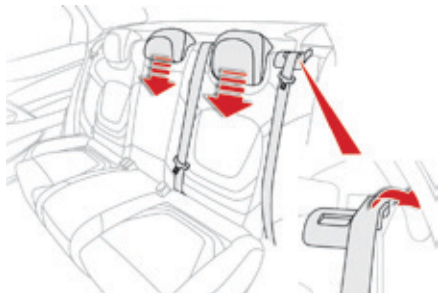

- ☞ Move the corresponding front seat forward if necessary.
- ☞ Place the head restraints in the low position or remove them.
- ☞ Remove the seat belt from its guide.



- ☞ Lift the cushion 1 by hand, lifting from the rear.

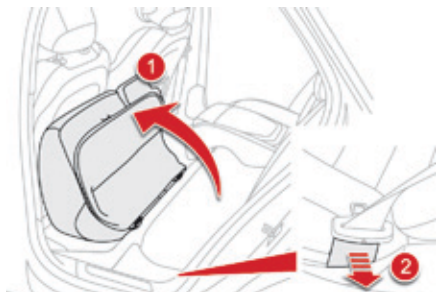

- ☞ Tip the seat cushion 1 fully against the front seat.
- ☞ Keep the seat belt guide 2 held against the vehicle.

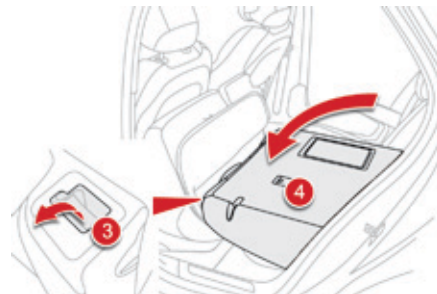

- ☞ Pull control 3 forwards to release the seat back 4.
- ☞ Fold the seat backrest 4.

## Repositioning the seat backrest and cushion

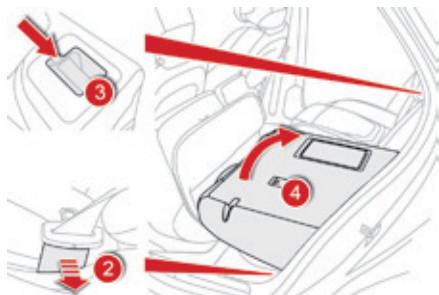

- ☞ Keep the seat belt guide **2** held against the vehicle to avoid trapping the seat belt when repositioning the seat.
- ☞ Straighten the seat back **4** while refitting the head restraints and secure it.
- ☞ Check that the red indicator, located next to the control **3**, is no longer visible.

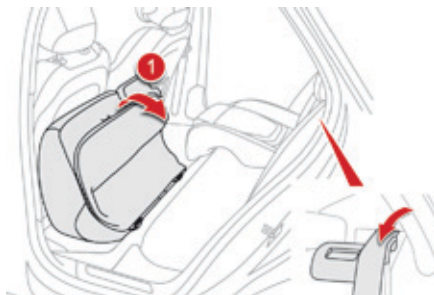

- ☞ Reposition the cushion **1**.
- ☞ Release the seat belt guide **2**.
- ☞ Put the seat belt back in place in the guide.

 When repositioning the seat backrest, take care not to trap the seat belts.





## Removing the seat cushion

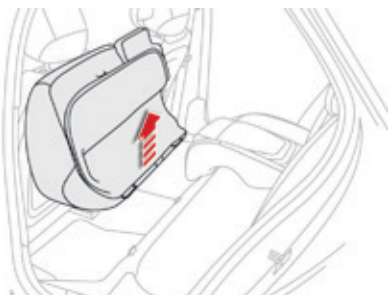

- ☞ Remove the seat cushion **1** from its fixings by pulling upwards.

## Refitting the seat cushion

- ☞ Position the seat cushion **1** vertically in its fixings.

## Rear head restraints

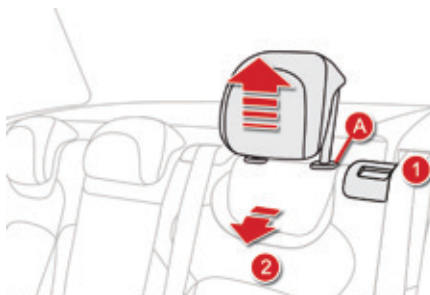

These have one position for use (up) and a stowed position (down).

They can also be removed.

To remove a head restraint:

- ☞ release the backrest using control **1**,
- ☞ tilt the backrest **2** slightly forwards,
- ☞ pull the head restraint upwards to the stop,
- ☞ then, press the lug **A**.

 Never drive with the head restraints removed; they must be in place and correctly adjusted.

# Mirrors

## Door mirrors

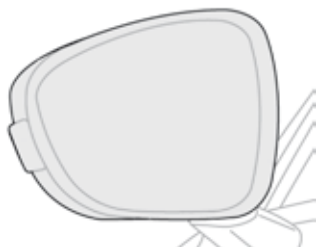

- ⚠ As a safety measure, the mirrors should be adjusted to reduce the blind spot.

## Demisting - Defrosting



Demisting-defrosting of the door mirrors operates by switching on the heated rear screen.

For more information, refer to the "Rear screen and door mirrors demist-defrost" section.

- ⚠ The rear screen demist - defrost can only operate when the engine is running.



## Adjustment

- ☞ Turn control **A** to the right or to the left to select the corresponding mirror.
- ☞ Move control **A** in all four directions to adjust.
- ☞ Return control **A** to the central position.

- ⓘ The objects observed are, in reality, closer than they appear. Take this into account in order to correctly judge the distance of vehicles approaching from behind.

## Folding

Automatic: lock the vehicle using the electronic key.



Manual: with the ignition on, move control **A** downwards.

- ⓘ If the mirrors are folded using control **A**, they will not unfold when the vehicle is unlocked.

## Unfolding

Automatic: unlock the vehicle using the electronic key.



Manual: with the ignition on, move control **A** upwards.

The mirrors can be folded manually if necessary.

- ⓘ The folding and unfolding of the door mirrors using the electronic key can be deactivated by a CITROËN dealer or a qualified workshop. Fold the mirrors when putting your vehicle through an automatic car wash.

## Rear view mirror

Adjustable mirror providing a central rearward view.

Equipped with an anti-dazzle system, which darkens the mirror glass and reduces the nuisance to the driver caused by the sun, headlamps from other vehicles...

## Automatic day/night model

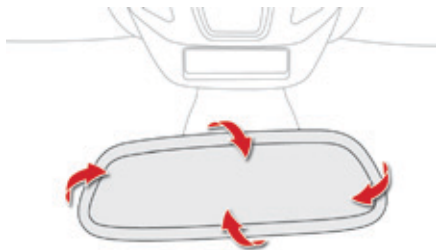

By means of a sensor, which measures the light from the rear of the vehicle, this system automatically and progressively changes between the day and night uses.

## Seeing clearly

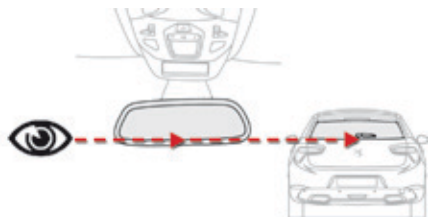

For better rear vision, align the bottom of the rear view mirror with the bottom of the rear screen.



In order to ensure optimum visibility during your manoeuvres, the mirror lightens automatically when reverse gear is engaged.

## Steering wheel adjustment

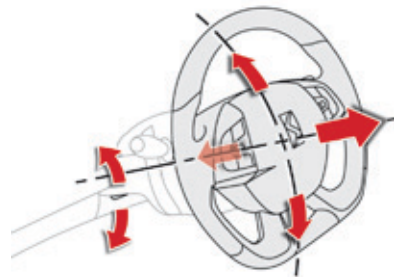

- ☞ **When stationary**, pull the control lever to release the adjustment mechanism.
- ☞ Adjust the height and reach to suit your driving position.
- ☞ Push the control lever to lock the adjustment mechanism.



As a safety measure, these operations should only be carried out with the vehicle stationary.

## Front fittings

1. **Glove box**
2. **Storage**
3. **Storage (according to version)**
4. **Ticket holder (according to version)**
5. **Removable ashtray / 12 V accessory socket (120 W)**

Press the lid to open the ashtray.

To empty the ashtray, remove it by pulling it upwards.

6. **Centre armrest and storage**

It is illuminated, cooled and contains storage spaces (1.5 litre bottle, ...).

7. **USB Player**

8. **12 V accessory socket (120 W)**

Observe the maximum power rating to avoid damaging your device.

9. **Door panel with cup holder**

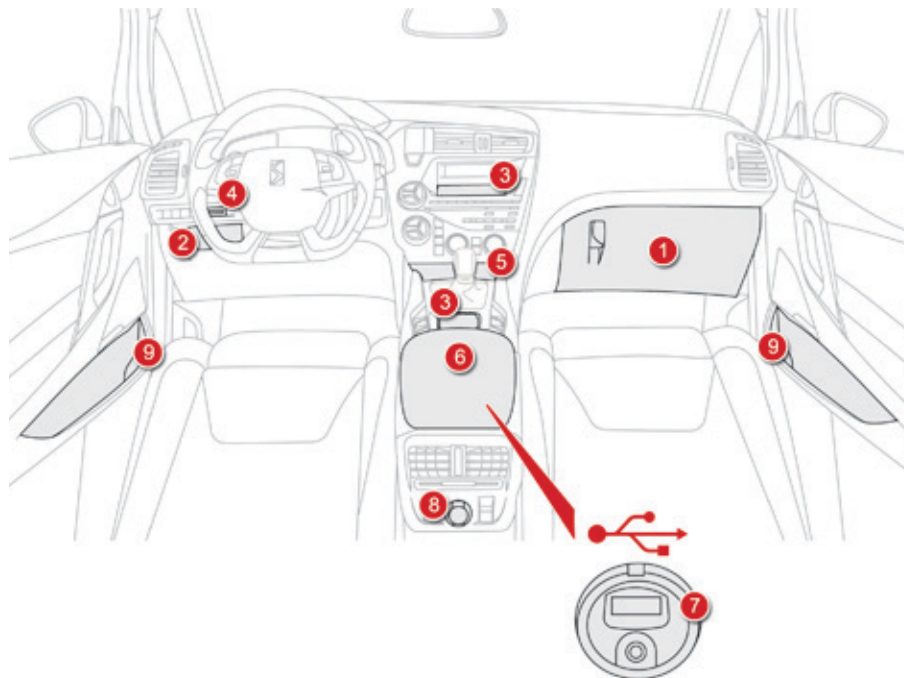



## Cigarette lighter / 12 V accessory socket

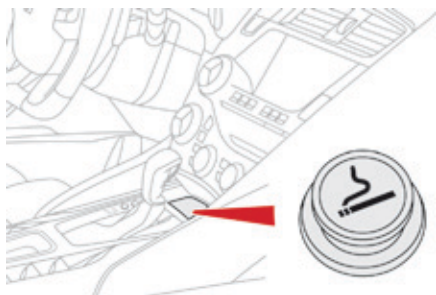

- ☞ To use the cigarette lighter, press it in and wait a few seconds until it pops out automatically.
- ☞ To connect a 12 V accessory (max power: 120 W), remove the cigarette lighter and connect a suitable adaptor.

You can use this socket to connect a telephone charger, a bottle warmer...  
After use, put the cigarette lighter back into place straight away.

 The connection of an electrical device not approved by CITROËN, such as a USB charger, may adversely affect the operation of vehicle electrical systems, causing faults such as poor telephone reception or interference with displays in the screens.

## Mats

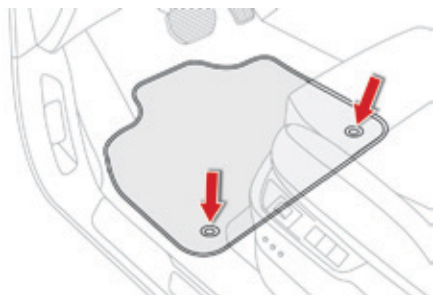

### Fitting

To fit the mat on the driver's side:

- ☞ move the seat fully back,
- ☞ fit the mat in place,
- ☞ engage the fixings by pressing down on them.

### Removal

To remove the mat on the driver's side:

- ☞ move the seat fully back,
- ☞ disengage the fixings, leaving the fixing pins in the floor carpet,
- ☞ remove the mat.

### Refitting

To refit the mat on the driver's side:

- ☞ position the mat correctly,
- ☞ refit the fixings by pressing,
- ☞ check that the mat is secured correctly.



To avoid any risk of jamming of the pedals:

- only use mats which are suited to the fixings already present in the vehicle; these fixings must be used,
- never fit one mat on top of another.

The use of mats not approved by CITROËN may interfere with access to the pedals and hinder the operation of the cruise control / speed limiter.



## Centre armrest

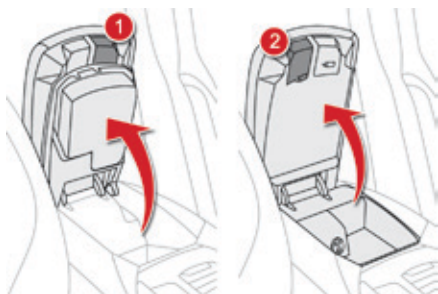

It contains two storage compartments.

### Storage compartments

- ☞ For access to the large compartment, press button 1 then raise the cover.
- ☞ For access to the small compartment (below the armrest cover) press button 2 then raise the cover.

The large compartment houses a USB port and a Jack auxiliary socket. It also houses an air vent (adjustable for flow) that delivers cooled air.

## USB Player



This connection box comprises a USB port and a Jack auxiliary socket.

### USB port

The USB port allows the connection of a portable device, such as a digital audio player of the iPod® type or a USB memory stick. The USB player reads your audio files, which are transmitted to your audio system and played via the vehicle's speakers. The management of these files is from the steering mounted controls or the audio system.

**i** When connected to the USB port, the portable device charges automatically. While charging, a message is displayed if the power consumption of the portable device exceeds the current delivered by the vehicle.

The USB port also allows a telephone to be connected by MirrorLink™ or CarPlay®, so that certain applications on the telephone can be used in the touch screen.

### Jack auxiliary socket

The Jack auxiliary socket allows the connection of a portable device, such as a digital audio player, so that your audio files can be heard through the vehicle's speakers. The management of these files is from the portable device.

**i** For more information, refer to the corresponding part of the "Audio and telematics" section.

## Rear fittings

### Rear armrest



- ☞ Lower the rear armrest for a more comfortable position.

It may be fitted with cup holders and also gives access to the ski flap.

### Ski flap



It allows long objects to be carried in the vehicle.

### Opening

- ☞ Lower the armrest.
- ☞ Press the flap opening control.
- ☞ Lower the flap.
- ☞ Load the objects from inside the boot.



Do not leave the flap open when not carrying long objects in the vehicle.



## Boot fittings

- 1. Rear shelf**  
It can be removed when carrying large objects.
- 2. Bag hooks**
- 3. Stowing rings**
- 4. Warning triangle retaining straps**

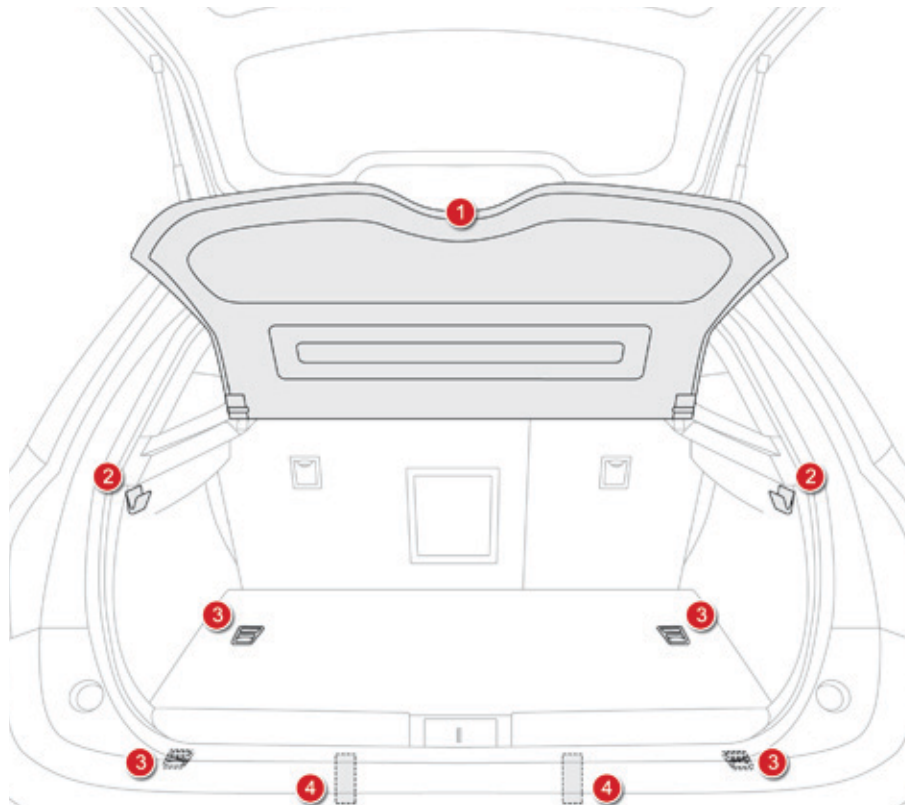

## Warning triangle (stowing)

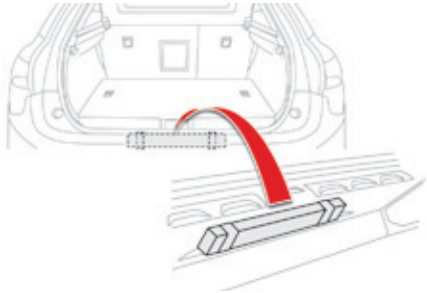

Use the straps on the interior boot trim to stow the folded triangle or its storage box.



### **Placing the triangle on the road**

Place the triangle behind the vehicle, as required by the legislation in force in your country.

# Heating and Ventilation

System which creates and maintains good conditions of comfort and visibility in the vehicle's passenger compartment.

## Controls

The incoming air follows various routes depending on the controls selected by the driver, the front passenger and rear passengers.

The temperature control enables you to obtain the level of comfort required by mixing the air of the various circuits.

The air distribution control enables you to select the air vents used in the passenger compartment by the combined use of the associated buttons.

The air flow control enables you to increase or reduce the speed of the ventilation fan. These controls are grouped together on control panel **A** on the centre console.

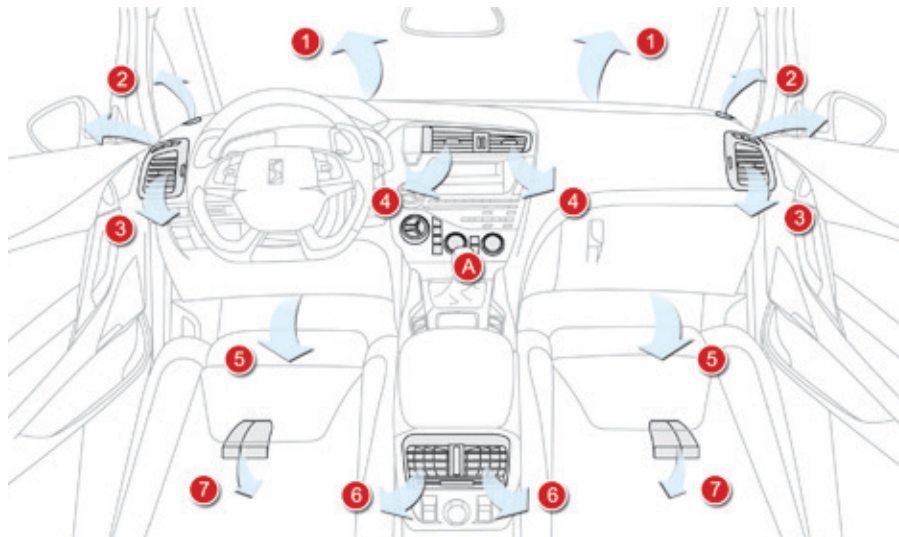

## Air distribution

1. Windscreen demisting/defrosting vents.
2. Front side quarter light window demisting/defrosting vents.
3. Side adjustable air vents.
4. Central adjustable air vents.
5. Air outlets to the driver and front passenger footwells.
6. Adjustable air vents for the rear passengers.
7. Air outlets to the rear footwells.

# Recommendations for ventilation and air conditioning



In order for these systems to be fully effective, follow the operation and maintenance guidelines below:

- ☞ To obtain an even air distribution, take care not to obstruct the exterior air intake grilles located at the base of the windscreen, the nozzles, the vents and the air outlets, as well as the air extractor located in the boot.
- ☞ Do not cover the sunshine sensor, located on the dashboard; this is used for regulation of the digital air conditioning system.
- ☞ Operate the air conditioning system for at least 5 to 10 minutes, once or twice a month to keep it in perfect working order.
- ☞ Ensure that the passenger compartment filter is in good condition and have the filter elements replaced regularly (refer to the "Checks" section).  
We recommend the use of a combined passenger compartment filter. Thanks to its special active additive, it contributes to the purification of the air breathed by the occupants and the cleanliness of the passenger compartment (reduction of allergic symptoms, bad odours and greasy deposits).
- ☞ To ensure correct operation of the air conditioning system, you are also advised to have it checked regularly as recommended in the maintenance and warranty guide.
- ☞ If the system does not produce cold air, switch it off and contact a CITROËN dealer or a qualified workshop.

You can switch off the air conditioning (AC button) and stay in Automatic mode in order to limit fuel consumption. If misting appears while in this mode, you can switch the air conditioning back on temporarily to improve the situation.

When towing the maximum load on a steep gradient in high temperatures, switching off the air conditioning increases the available engine power and so improves the towing ability.



If after an extended stop in sunshine, the interior temperature is very high, first ventilate the passenger compartment for a few moments.

Put the air flow control at a setting high enough to quickly change the air in the passenger compartment.

The air conditioning system does not contain chlorine and does not present any danger to the ozone layer.



The condensation created by the air conditioning results in a discharge of water under the vehicle which is perfectly normal.

If you want to prioritise heating, start and leave the engine running by pressing ECO OFF.

# Dual-zone digital air conditioning

## Automatic operation

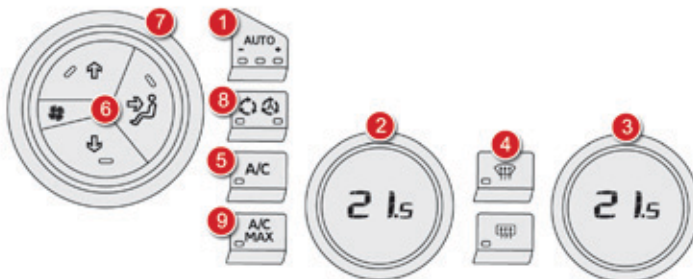

### 1. Automatic comfort programme



We recommend the use of one of the three AUTO modes available: they provide optimised regulation of the temperature in the passenger compartment according to the comfort value that you have chosen.

These three modes automatically control the system, according to the desired setting, while also maintaining the desired comfort value.

This system is designed to operate effectively in all seasons, with the windows closed.

- ☞ Press the "AUTO" button repeatedly:
  - a first indicator lamp comes on; the "low" setting mode is selected,
  - a second indicator lamp comes on; the "medium" setting mode is selected,
  - a third indicator lamp comes on; the "high" mode setting is selected.

Use the "medium" and "high" settings in preference to maintain the comfort level at the rear.

**i** When the engine is cold, the air flow will reach its optimum level progressively, taking account of the weather and the desired comfort level so as to avoid too great a distribution of cold air.

On entering the vehicle, if the interior temperature is much colder or warmer than the comfort value, there is no need to change the value displayed in order to obtain the comfort required. In all seasons, with the windows closed the system corrects the difference in temperature automatically and as quickly as possible.

## 2-3. Driver's-passenger's side settings



The driver and front passenger can each adjust the temperature to their requirements.

The value indicated on the display corresponds to a level of comfort and not to a temperature in degrees Celsius or Fahrenheit.

- ☞ Turn control **2** or **3** to the left or to the right respectively to decrease or increase this value.

A setting around the value 21 provides optimum comfort. However, depending on your requirements, a setting between 18 and 24 is normal.

You are advised to avoid a left / right setting difference of more than 3.

## 4. Automatic visibility programme



For more information on the automatic visibility programme, refer to the corresponding section in "Front demisting - defrosting".

- ℹ With Stop & Start, when demisting has been activated, the STOP mode is not available.

## Manual operation

If you wish, you can make a different choice from that offered by the system by changing a setting. The "**AUTO**" indicator lamps go off; the other functions, except the air conditioning, will still be controlled automatically.

- ☞ Pressing the "**AUTO**" button returns the system to completely automatic operation.

- ℹ For maximum cooling or heating of the passenger compartment, it is possible to exceed the minimum value 14 or the maximum value 28.

- ☞ Turn control **2** or **3** to the left until "**LO**" is displayed or to the right until "**HI**" is displayed.

## 5. Air conditioning On / Off



- ☞ Press this button to switch off the air conditioning.

Switching the system off could result in discomfort (humidity, condensation).

- ☞ Press this button again to return to automatic operation of the air conditioning. The indicator lamp in the "A/C" button comes on.

To obtain cool air more quickly, you can use recirculation of the interior air for a few moments. Then revert to the intake of exterior air.

## 6. Air distribution adjustment



- ☞ Press one or more buttons to direct the air flow towards:
  - the windscreen and side windows,
  - the outer and centre air vents,
  - the footwells.

You can combine the three orientations to obtain the desired air distribution.

## 7. Air flow adjustment



- ☞ Turn this control to the left to decrease the air flow or to the right to increase the air flow.

The air flow indicator lamps, between the two fans, come on progressively in relation to the value requested.

## 8. Air intake / Air recirculation

Interior air recirculation enables the passenger compartment to be isolated from exterior odours and smoke when external pollution is detected.

It is activated automatically on operation of the screenwash.

It is inactive when the ambient temperature is below 5 °C to avoid the risk of misting in the vehicle.



- The indicator lamp "with "A" on indicates that recirculation is controlled automatically.
- The indicator lamp "without "A" on indicates that recirculation is forced manually.
- Both indicator lamps off indicates that recirculation is controlled automatically without taking account of the detection of pollution.



Avoid prolonged operation in interior air recirculation mode or driving for long periods with the system off (risk of condensation and deterioration of air quality).

## 9. Maximum air conditioning



- ☞ If you want to quickly cool the air in the passenger compartment, press this button; "LO" is displayed.

To return to the previous settings, press the button again.

## Switching the system off



- ☞ Turn the air flow control to the left until all of the indicator lamps go off.

This action switches off the air conditioning and the ventilation.

Temperature related comfort is no longer assured but a slight flow of air, due to the movement of the vehicle, can still be felt.

- ☞ Modify the settings (temperature, air flow or air distribution) or press the "AUTO" button to reactivate the system with the values set before it was switched off.



# Front demist - defrost

## Automatic visibility programme



- Select this programme to demist or defrost the windscreen and side windows as quickly as possible.

The system automatically manages the air conditioning, air flow and air intake, and provides optimum distribution towards the windscreen and side windows.

- To stop the programme, press either the **"visibility"** button again or **"AUTO"**, the indicator lamp in the button goes off and the indicator lamp in the **"AUTO"** button comes on.

The system starts again with the values in use before it was overridden by the visibility programme.

- With Stop & Start, when demisting has been activated, the STOP mode is not available.

# Rear screen and door mirrors demist - defrost

## Switching on



- Press this button (located on the air conditioning system control panel) to demist/defrost the rear screen and the door mirrors. The indicator lamp associated with the button comes on.

## Switching off

The demisting/defrosting switches off automatically to prevent an excessive consumption of current.



- It is possible to stop the demisting/defrosting operation before it is switched off automatically by pressing the button again. The indicator lamp associated with the button goes off.



- Switch off the demisting/defrosting of the rear screen and door mirrors as soon as appropriate, as lower current consumption results in reduced fuel consumption.



- The rear screen demist - defrost can only operate when the engine is running.

**004**

Driving



# Driving recommendations

Observe the driving regulations and remain vigilant whatever the traffic conditions.

Pay close attention to the traffic and keep your hands on the wheel so that you are ready to react at any time to any eventuality.

On a long journey, a break every two hours is strongly recommended.

In difficult weather, drive smoothly, anticipate the need to brake and increase the distance from other vehicles.

## Driving on flooded roads

We strongly advise against driving on flooded roads, as this could cause serious damage to the engine or gearbox, as well as to the electrical systems of your vehicle.

If you are obliged to drive through water:

- check that the depth of water does not exceed 15 cm, taking account of waves that might be generated by other users,
- deactivate the Stop & Start system,
- drive as slowly as possible without stalling. In all cases, do not exceed 6 mph (10 km/h),
- do not stop and do not switch off the engine.



On leaving the flooded road, as soon as circumstances allow, make several light brake applications to dry the brake discs and pads. If in doubt on the state of your vehicle, contact a CITROËN dealer or a qualified workshop.

## Important!

 Never drive with the parking brake applied - Risk of overheating and damage to the braking system!  
Do not park or run the engine when stationary in areas where inflammable substances and materials (dry grass, dead leaves...) might come into contact with the hot exhaust system - Risk of fire!

 Never leave a vehicle unsupervised with the engine running. If you have to leave your vehicle with the engine running, apply the parking brake and put the gearbox into neutral or position **N** or **P**, depending on the type of gearbox.



## When towing

### Distribution of loads

- ☞ Distribute the load in the trailer so that the heaviest items are as close as possible to the axle and the nose weight approaches the maximum permitted without exceeding it.

Air density decreases with altitude, thus reducing engine performance. Above 1 000 metres, the maximum towed load must be reduced by 10 % for every 1 000 metres of altitude.

For more information on weights (and the towed loads which apply to your vehicle) refer to the corresponding section.

### Side wind

- ☞ Take into account the increased sensitivity to side wind.

### Cooling

Towing a trailer on a slope increases the temperature of the coolant.

As the fan is electrically controlled, its cooling capacity is not dependent on the engine speed.

- ☞ To lower the engine speed, reduce your speed.

The maximum towed load on a long incline depends on the gradient and the ambient temperature.

In all cases, keep a check on the coolant temperature.



- ☞ If the warning lamp and the **STOP** warning lamp come on, stop the vehicle and switch off the engine as soon as possible.

### Braking

Towing a trailer increases the braking distance. To avoid overheating of the brakes, the use of engine braking is recommended.

### Tyres

- ☞ Check the tyre pressures of the towing vehicle and of the trailer, observing the recommended pressures.

### Lighting

- ☞ Check the electrical lighting and signalling on the trailer and the headlamp beam height of your vehicle.

For more information on adjusting the headlamp beam height, refer to the corresponding section.



The rear parking sensors will be deactivated automatically if a genuine CITROËN towbar is used.

# Starting / Switching off the engine

With a **manual gearbox**, put the gear lever into neutral.

With an **automatic gearbox**, place the gear selector at position **P** or **N**.

## Starting using the electronic key

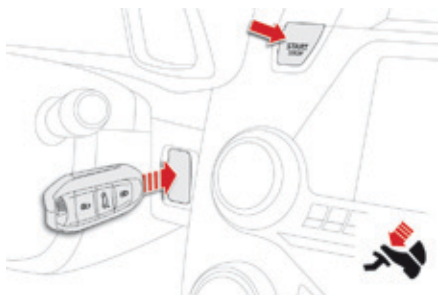

- ☞ Insert the electronic key in the reader.
- ☞ Press the brake pedal for vehicles with an automatic gearbox, or fully de clutch for vehicles with a manual gearbox.

- ☞ Press the **"START/STOP"** button while maintaining pressure on the pedal until the engine starts.

The steering column unlocks and the engine starts more or less instantly.  
See the advice below for Diesel vehicles.

## Starting with Keyless Entry and Starting

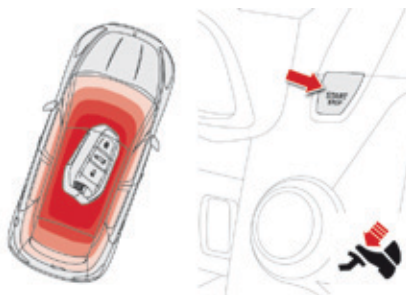

It is not necessary to place the electronic key in the reader.

- ☞ With the electronic key inside the vehicle, press the brake pedal for vehicles with an automatic gearbox, or fully depress the clutch pedal for vehicles with a manual gearbox.
- ☞ Press the **"START/STOP"** button while maintaining pressure on the pedal until the engine starts.

The steering column unlocks and the engine starts more or less instantly.  
See the warning below for Diesel vehicles.

**i** If one of the starting conditions is not met, a reminder message appears in the instrument panel screen. In some circumstances, it is necessary to turn the steering wheel slightly while pressing the **"START/STOP"** button to assist unlocking of the steering; a message warns you when this is needed.

The "Keyless Entry and Starting" electronic key must be in the recognition zone.  
For safety reasons, do not leave this zone with the vehicle running.  
If the electronic key is not detected in the recognition zone, a message is displayed. Move the electronic key into the zone so that the engine can be started.

## **D** **o** **d** Diesel vehicles

In temperatures below zero the engine will not start until the pre-heater warning lamp has gone off.  
If this warning lamp comes on after pressing **"START/STOP"**, you should hold the brake or clutch pedal down until the warning lamp goes off and do not press the **START/STOP** button again.

## Switching off using the electronic key

☞ Immobilise the vehicle.



☞ Press the "START/STOP" button.

The engine stops and the steering column locks.

☞ Remove the electronic key from the reader.

### Electronic key left in the reader

If the electronic key is left in the reader, on opening the driver's door a message appears to warn you.

## Switching off with Keyless Entry and Starting

☞ Immobilise the vehicle.



☞ With the electronic key inside the vehicle, press the "START/STOP" button.

The engine stops and the steering column locks.



Switching off the engine leads to a loss of braking assistance.

## Switching the ignition on (without starting)

With the electronic key in the reader or the Keyless Entry and Starting key inside the vehicle, pressing the "START/STOP" button, **with no action on the pedals**, allows the ignition to be switched on.



☞ Press the "START/STOP" button, the instrument panel comes on but the engine does not start.

☞ Press the button again to switch off the ignition and so allow the vehicle to be locked.



With the ignition on, the system goes into energy economy mode when necessary to maintain the state of charge of the battery.



If the vehicle is not immobilised, the engine will not stop. Never leave your vehicle with the electronic key still inside.

## Anti-theft protection

### Electronic engine immobiliser

The keys contain an electronic chip which has a secret code. When the ignition is switched on, this code must be recognised in order for starting to be possible.

This electronic engine immobiliser locks the engine management system a few minutes after the ignition is switched off and prevents starting of the engine by anyone who does not have the key.

In the event of a malfunction, you are informed by a message in the instrument panel screen. In this case, your vehicle does not start; contact a CITROËN dealer as soon as possible.

## Emergency starting with the "Keyless Entry and Starting" system

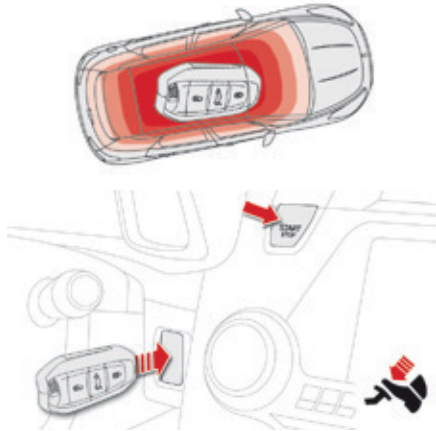

When the electronic key is in the recognition zone and your vehicle does not start after pressing the "**START/STOP**" button:

- ☞ Insert the electronic key in the reader.
- ☞ Press the brake pedal on vehicles with an automatic gearbox, or fully declutch with a manual gearbox.
- ☞ Press the "**START/STOP**" button. The engine starts.

## Emergency switch-off



In the event of an emergency only, the engine can be switched off without conditions. To do this, press and hold the "**START/STOP**" button for about 3 seconds. In this case the steering column locks as soon as the vehicle stops.

## Electronic key not recognised by the "Keyless Entry and Starting" system



If the electronic key is no longer in the recognition zone when driving or when you (later) request switching off the engine, a message appears in the instrument panel.



- ☞ Press and hold the "**START/STOP**" button for about 3 seconds if you want to force switching off the engine.

**i** Note that restarting will not be possible without the key.



# Electric parking brake

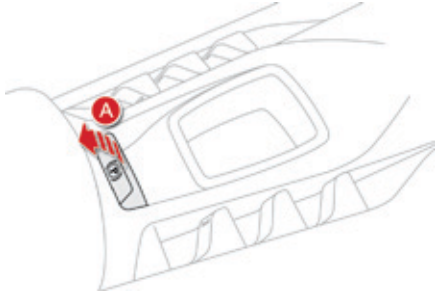

The electric parking brake combines 2 operating modes:

- **Automatic Application/Release**  
Application is automatic when the engine stops, release is automatic on use of the accelerator (this mode is activated by default).
- **Manual Application/Release**  
Manual application of the parking brake is done by pulling control lever **A**. Manual release is by **pulling** then releasing the control lever, while pressing the brake pedal.

**i** When the driver's door is opened, there is an audible signal and a message is displayed if the parking brake is not applied.

## Programming the automatic mode

For some countries of sale, it is possible to deactivate automatic operation.



In this case, deactivation is done via the vehicle configuration menu.



If automatic mode is deactivated, the parking brake must be applied and released manually.

If this warning lamp comes on in the instrument panel, the automatic mode is deactivated.

## Label on door panel



**!** Never leave the vehicle without checking that the parking brake is on.



This warning lamp comes on fixed.

## **!** Very cold conditions or when towing

In these circumstances, it is recommended that you do not apply the parking brake.

For this, with the ignition on, deactivate the automatic functions and release the parking brake manually:

- ☞ **Manual gearbox:** engage first gear or reverse.
- ☞ **Automatic gearbox:** select position **P**.

## **!** Discharged battery

In this case, the electric parking brake no longer functions.

As a safety measure, immobilise the vehicle following the recommendations above or by placing a chock against one of the wheels.

Call on a CITROËN dealer or a qualified workshop.

## Manual application

With the vehicle stationary, to apply the parking brake whether the engine is running or off, **pull** control lever **A**.

The application of the parking brake is confirmed by:



- illumination of the braking warning lamp and of the **P** warning lamp in the control lever **A**,
- display of the message "Parking brake on".

With the engine running, when the driver's door is opened there is an audible signal and a message is displayed if the parking brake has not been applied - unless the selector lever is in position **P** (Park) in the case of an automatic gearbox.



Before leaving the vehicle, check that parking brake warning lamps in the instrument panel and the control lever **A** are on fixed, not flashing.

## Manual release

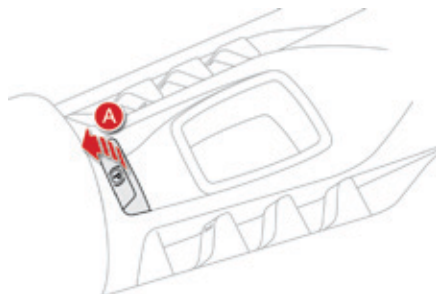

With the ignition on or the engine running, to release the parking brake, **press** the **brake pedal**, **pull** then release control lever **A**. The full release of the parking brake is confirmed by:



- the braking warning lamp and the **P** warning lamp in the control lever **A** going off,
- display of the message "Parking brake off".

If you pull the control lever **A** without pressing the brake pedal, the parking brake will not be released and a message appears in the instrument panel.

## Maximum application

If necessary, you can make a **maximum application** of the parking brake. It is obtained by means of a **long pull** on control lever **A**, until you see the message "Parking brake applied fully" and an audible signal is heard.

### Maximum application is essential:

- in the case of a vehicle towing a caravan or a trailer, if the automatic functions are activated but you are applying the parking brake manually,
- when the slope you are parked on may vary (e.g. on a ferry, on a lorry, during towing).





In the case of towing, a loaded vehicle or parking on a gradient, make a maximum application of the parking brake then turn the front wheels towards the pavement and engage a gear when you park. After a maximum application, the release time will be longer.

## Automatic application, engine off

With the vehicle stationary, the parking brake is automatically applied when the engine is switched off.



The application of the parking brake is confirmed by:

-  - illumination of the braking warning lamp and of the **P** warning lamp in the control lever **A**,
- display of the message "Parking brake on".

 Before leaving the vehicle, check that parking brake warning lamps in the instrument panel and in the control lever **A** are on fixed (not flashing). Never leave a child alone inside the vehicle with the ignition on, as they could release the parking brake.

## Automatic release

The electric parking brake releases automatically and progressively when you press the accelerator :

-  **Manual gearbox**: fully depress the clutch pedal, engage 1<sup>st</sup> or reverse gear; press the accelerator pedal and let up the clutch pedal until the brake releases.
-  **Automatic gearbox**: select position **D**, **M** or **R** then press the accelerator pedal.

Full release of the parking brake is confirmed by:

-  - the braking warning lamp and the **P** warning lamp in the control lever **A** going off,
- display of the message "Parking brake off".

 When stationary, with the engine running, do not press the accelerator pedal unnecessarily, as you may release the parking brake.

## Immobilising the vehicle, engine running

With the engine running and the vehicle stationary, in order to immobilise the vehicle it is essential to manually apply the parking brake by pulling control lever **A**.

The application of the parking brake is confirmed by:

-  - illumination of the braking warning lamp and of the **P** warning lamp in the control lever **A**,
- display of the message "Parking brake on".

With the engine running, when the driver's door is opened there is an audible signal and a message is displayed if the parking brake has not been applied - unless the selector lever is in position **P** (Park) in the case of an automatic gearbox.

 Before leaving the vehicle, check that parking brake warning lamps in the instrument panel and the control lever **A** are on fixed, not flashing.

## Emergency braking

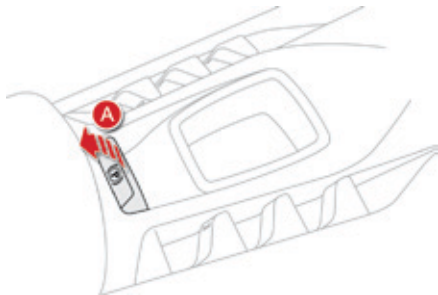

The emergency braking must only be used in exceptional circumstances.



In the event of a failure of the main service brake or in an exceptional situation (e.g. driver taken ill, under instruction, etc) a continuous pull on the control lever **A** will stop the vehicle.

The DSC system provides stability when braking during emergency braking. If the emergency braking malfunctions, the message "Parking brake control faulty" will be displayed.

## Special situations

In some circumstances (engine start...), the parking brake may adjust the level of application itself. This is normal operation.

To move your vehicle a few centimetres without starting the engine, with the ignition on, press the brake pedal and release the parking brake **by pulling** then **releasing** the control lever **A**.

Complete release of the parking brake is indicated by the warning lamps in the control lever **A** and in the instrument panel going off and by the display of the message "Parking brake off".

To ensure correct operation, and so your safety, the number of successive applications and releases of the parking brake is limited to eight cycles.



If used excessively, you are alerted by the message "parking brake faulty" and a flashing warning lamp.









 If a failure of the DSC system is signalled by the illumination of this warning lamp, then braking stability is not guaranteed. In this event, stability must be assured by the driver by repeating alternate "pull-release" actions on the control lever **A**.



## Operating faults

If the electric parking brake fault warning lamp comes on together with one or more of the warning lamps presented in these tables, immobilise the vehicle on flat and level ground, engage a gear, place chock against one of the wheels if necessary and switch off the ignition. Contact a dealer or a without delay. Call on a CITROËN dealer or a qualified workshop without delay.

Alert	Consequences
Display of the message <b>"Parking brake fault"</b> and illumination of these warning lamps:  	<ul style="list-style-type: none"> <li>- The automatic functions are deactivated.</li> <li>- Hill start assist is not available.</li> <li>- The electric parking brake can only be used manually.</li> </ul>
Display of the message <b>"Parking brake fault"</b> and illumination of these warning lamps:  	<ul style="list-style-type: none"> <li>- Manual release of the electric parking brake is only possible by pressing the accelerator pedal and pulling the control lever.</li> <li>- Hill start assist is not available.</li> <li>- The automatic functions and the manual application are still available.</li> </ul>
Display of the message <b>"Parking brake fault"</b> and illumination of these warning lamps:  	<ul style="list-style-type: none"> <li>- The automatic functions are deactivated.</li> <li>- Hill start assist is not available.</li> </ul>

Alert	Consequences
<p style="text-align: center;">     </p> <p>and possibly</p> <p style="text-align: center;">  </p> <p>flashing</p>	<p>To apply the electric parking brake:</p> <ul style="list-style-type: none"> <li>☞ immobilise the vehicle and switch off the ignition.</li> <li>☞ pull the control for at least 5 seconds or until application is complete.</li> <li>☞ switch on the ignition and check that the electric parking brake warning lamps come on.</li> </ul> <p>The application is slower than during normal operation.</p> <p>To release the electric parking brake:</p> <ul style="list-style-type: none"> <li>☞ switch on the ignition.</li> <li>☞ pull the control lever and hold it for approximately 3 seconds then release it.</li> </ul> <p>If the braking warning lamp is flashing or if the warning lamps do not come on with the ignition on, these procedures will not work. Place the vehicle on level ground and have it checked by a CITROËN dealer or a qualified workshop.</p>
<p>Display of the message "<b>Parking brake fault</b>" and illumination of these warning lamps:</p> <p style="text-align: center;">  </p> <p>and possibly</p> <p style="text-align: center;">  </p> <p>flashing</p>	<ul style="list-style-type: none"> <li>- Only the automatic application on switching off the engine and automatic release on acceleration functions are available.</li> <li>- The manual application/release of the electric parking brake and the emergency braking are not available.</li> </ul>
<p>Display of the message "<b>Battery charge fault</b>".</p> <p style="text-align: center;">  </p>	<ul style="list-style-type: none"> <li>- You must stop as soon as it is safe to do so. Switch off and immobilise your vehicle (if necessary, place the a chock under a wheel).</li> <li>- Apply the electric parking brake before switching off the engine.</li> </ul>

## Hill start assist

System which keeps your vehicle immobilised temporarily (approximately 2 seconds) when starting on a gradient, the time it takes to move your foot from the brake pedal to the accelerator pedal.

This system only operates when:

- the vehicle is completely stationary, with your foot on the brake pedal,
- certain gradient conditions are met,
- with the driver's door closed.

The hill start assist system cannot be deactivated.

### Operation

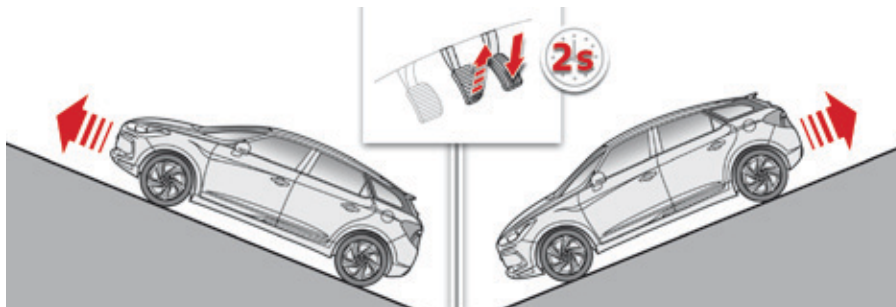

**On an ascending slope, with the vehicle stationary, the vehicle is held for a momentarily when you release the brake pedal:**

- provided you are in first gear or neutral with a manual gearbox,
- provided you are in position **D** or **M** with an automatic gearbox.

**On a descending slope, with the vehicle stationary and reverse gear engaged, the vehicle is held momentarily when you release the brake pedal.**

### Operating fault



**SERVICE**

If a fault in the system occurs, these warning lamps come on. Contact a CITROËN dealer or a qualified workshop to have the system checked.



Do not leave the vehicle while it is being held in the hill start assist phase. If you need to leave the vehicle with the engine running, apply the parking brake manually then ensure that the parking brake warning lamp and the warning lamp **P** in the lever of the electric parking brake control are on fixed (not flashing).

# 6-speed manual gearbox

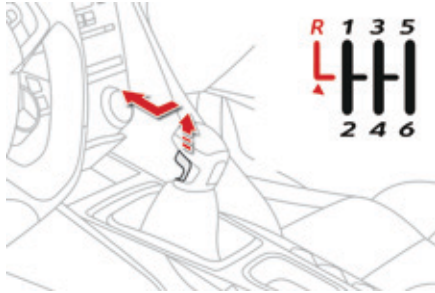

## Engaging 5<sup>th</sup> or 6<sup>th</sup> gear

- ☞ Move the lever fully to the right to engage 5<sup>th</sup> or 6<sup>th</sup> gear.

 Failure to follow this advice could cause permanent damage to the gearbox (inadvertent engagement of 3<sup>rd</sup> or 4<sup>th</sup> gear).

## Engaging reverse gear

- ☞ Raise the trigger under the knob and move the gear lever to the left then forwards.

 Only engage reverse gear when the vehicle is stationary with the engine at idle.

 As a safety precaution and to facilitate starting of the engine, always select neutral and depress the clutch pedal.



# Automatic gearbox

Six speed automatic gearbox which offers a choice between the comfort of fully automatic operation, enhanced by sport and snow programmes, and the pleasure of manual gear changing.

Two driving modes are offered:

- **automatic** operation for electronic management of the gears by the gearbox, with a **sport** programme for a more dynamic style of driving and a **snow** programme to improve driving when traction is poor,
- **manual** operation for sequential changing of the gears by the driver.

## Gear selection gate

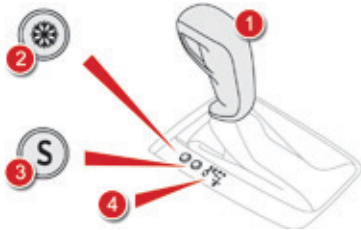

1. Gear selector.
2. Button "❄" (**snow**).
3. Button "S" (**sport**).
4. Position markings for the gear selector.

## Gear selector positions



- P.** Park.
  - Immobilisation of the vehicle, parking brake on or off.
  - Starting the engine.
- R.** Reverse.
  - Reversing manoeuvres, vehicle stationary, engine at idle.
- N.** Neutral.
  - Immobilisation of the vehicle, parking brake on.
  - Starting the engine.
- D.** Automatic operation.
- M.+ / -** Manual operation with sequential changing of the six gears.
  - ☞ Push forwards to change up through the gears.  
or
  - ☞ Pull backwards to change down through the gears.

## Displays in the instrument panel



When you move the selector in the gate to select a position, the corresponding indicator comes on in the instrument panel.

- P** Park
- R** Reverse
- N** Neutral
- D** Drive (automatic driving)
- S** Sport programme
- ❄ **Snow** programme
- 1 to 6** Gear engaged during manual operation
  - Invalid value during manual operation

## Moving off

- ☞ With your foot on the brake, select position **P** or **N**.
- ☞ Start the engine.

If this procedure is not followed, an audible signal is heard, accompanied by a message in the instrument panel screen.

- ☞ With the engine running, press the brake pedal.
- ☞ Select position **R**, **D** or **M**.



If you do not press the brake pedal when trying to move the gear selector out of position **P**, this warning lamp or this symbol appears in the instrument panel accompanied by a message, flashing of the **P** symbol, the display of a message and an audible signal.

- ☞ Check that the display in the instrument panel agrees with the position engaged.
- ☞ Gradually release the brake pedal.

The parking brake is released manually, the vehicle moves off.

If the parking brake is on and automatic mode is activated, accelerate progressively.



If the parking brake does not release automatically, check that the front doors are fully closed.



If position **N** is engaged inadvertently while driving, allow the engine to return to idle then engage position **D** to accelerate.



When the engine is running at idle, with the brakes released, if position **R**, **D** or **M** is selected, the vehicle moves even without the accelerator being pressed.  
Never leave children unsupervised in the vehicle when the engine is running.  
When carrying out maintenance with the engine running, apply the parking brake and select position **P**.

## Automatic operation

- ☞ Select position **D** for **automatic** changing of the six gears.

The gearbox then operates in auto-adaptive mode, without any intervention on the part of the driver. It continuously selects the most suitable gear according to the style of driving, the profile of the road and the load in the vehicle.

For maximum acceleration without touching the selector, press the accelerator pedal down fully (kick down). The gearbox changes down automatically or maintains the gear selected until the maximum engine speed is reached.

On braking, the gearbox changes down automatically to provide effective engine braking.

If you release the accelerator sharply, the gearbox will not change to a higher gear for safety reasons.



Never select position **N** while the vehicle is moving.  
Never select positions **P** or **R** unless the vehicle is completely stationary.

## Sport and snow programmes

These two special programmes supplement the automatic operation in very specific conditions of use.

### Sport programme "S"

☞ Press button "S", after starting the engine. The gearbox automatically favours a dynamic style of driving.



S appears in the instrument panel.

### Snow programme "❄"

☞ Press button "❄", after starting the engine. The gearbox adapts to driving on slippery roads. This programme improves starting and drive when traction is poor.



❄ appears in the instrument panel.

## Return to auto-adaptive mode

☞ At any time, press the button selected again to leave the special programme engaged and return to auto-adaptive mode.

## Manual operation

- ☞ Select position **M** for **sequential** changing of the six gears.
- ☞ Push the selector towards the + sign to change up a gear.
- ☞ Pull the selector towards the - sign to change down a gear.

It is only possible to change from one gear to another if the vehicle speed and engine speed permit; otherwise, the gearbox will operate temporarily in automatic mode.



**D** disappears and the gears engaged appear in succession on the instrument panel.

If the engine speed is too low or too high, the gear selected flashes for a few seconds, then the actual gear engaged is displayed. When the vehicle is stationary or moving very slowly, the gearbox selects gear **1** automatically.

It is not necessary to release the accelerator when changing gear.

It is possible to change from position **D** (automatic) to position **M** (manual) at any time. The sport and snow programmes do not operate in manual mode.

## Invalid value during manual operation



This symbol is displayed if a gear is not engaged correctly (selector between two positions).

## Stopping the vehicle

Before switching off the engine, put the selector in position **P** or **N** to place the gearbox in neutral.

In both cases, apply the parking brake to immobilise the vehicle, unless it is programmed to automatic mode.



If the selector is not in position **P**, when the driver's door is opened or approximately 45 seconds after the ignition is switched off, there is an audible signal and a message appears.

☞ Return the selector to position **P**; the audible signal stops and the message disappears.

## Operating fault

When the ignition is on, a message appears in the instrument panel screen to indicate a gearbox fault.

In this case, the gearbox switches to back-up mode and is locked in 3rd gear. You may feel a substantial knock when changing from **P** to **R** and from **N** to **R**. This will not cause any damage to the gearbox.

Do not exceed 60 mph (100 km/h), local speed restrictions permitting.

Have it checked by a CITROËN dealer or a qualified workshop.



You risk damaging the gearbox:

- if you press the accelerator and brake pedals at the same time,
- if you force the selector from position **P** to another position when the battery is flat.



To reduce fuel consumption when stationary for long periods with the engine running (traffic jam...), position the gear selector at **N** and apply the parking brake, unless it is programmed in automatic mode.

# Gear efficiency indicator\*

System which reduces fuel consumption by recommending the most appropriate gear.

## Operation

Depending on the driving situation and your vehicle's equipment, the system may advise you to skip one (or more) gear(s). You can follow this instruction without engaging the intermediate gears.

The gear engagement recommendations must not be considered compulsory. In fact, the configuration of the road, the amount of traffic and safety remain determining factors when choosing the best gear. Therefore, the driver remains responsible for deciding whether or not to follow the advice given by the system. This function cannot be deactivated.

**i** With an automatic gearbox, the system is only active in manual mode.

On BlueHDi Diesel 135 and 150 versions with manual gearbox, in certain driving conditions the system may suggest changing into neutral so that the engine can go into standby (STOP mode with Stop & Start). In this case, **N** is displayed in the instrument panel.

The information appears in the instrument panel in the form of an arrow.

**i** On vehicle fitted with a manual gearbox, the arrow may be accompanied by the gear recommended.

Example:

- You are in third gear.
- You press the accelerator pedal.
- The system may suggest that you engage a higher gear.



**i** The system adapts its gear change recommendation according to the driving conditions (slope, load, ...) and the demands of the driver (power, acceleration, braking, ...).  
The system never suggests:

- engaging first gear,
- engaging reverse gear.

\* Depending on engine.

# Tyre under-inflation detection

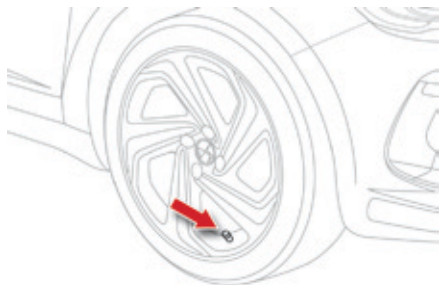

System which automatically checks the pressures of the tyres while driving. The system continuously monitors the pressures of the four tyres, as soon as the vehicle is moving. A pressure sensor is located in the valve of each tyre (except the spare wheel). The system triggers an alert if a drop in pressure is detected in one or more tyres.

 The tyre under-inflation detection system is an aid to driving which does not replace the need for vigilance on the part of the driver.

 This system does not avoid the need to check the tyre pressures regularly (including the spare wheel) and before a long journey. Driving with under-inflated tyres adversely affects road holding, extends braking distances and causes premature tyre wear, particularly under arduous conditions (vehicle loaded, high speed, long journey).

 Driving with under-inflated tyres increases fuel consumption.

 The tyre pressures for your vehicle can be found on the tyre pressure label. The tyre pressures must be checked when the tyres cold (vehicle stopped for 1 hour or after driving for less than 6 miles (10 km) at moderate speed). Otherwise, add 0.3 bar to the values indicated on the label. For more information on identification markings, including the tyre pressure label, refer to the corresponding section.

## Under-inflation alert



The alert is given by the fixed illumination of this warning lamp, accompanied by an audible signal, and depending on equipment, the display of a message.

In the event of a problem on one of the tyres, the symbol or the message appears, according to equipment, to identify it.

- ☞ Reduce speed, avoid sudden steering movements or harsh brake applications.
- ☞ Stop as soon as it is safe to do so.
  
- ☞ If you have a compressor (the one in the temporary puncture repair kit for example), check the four tyre pressures when cold. If it is not possible to check the tyre pressures at the time, drive carefully at reduced speed.  
or
- ☞ In the event of a puncture, use the temporary puncture repair kit or the spare wheel (according to equipment).



The alert is maintained until the tyre or tyres concerned is reinflated, repaired or replaced.  
The spare wheel (space-saver type or a steel rim) does not have a sensor.



The loss of pressure detected does not always lead to visible deformation of the tyre.  
Do not rely on just a visual check.

## Operating fault



The flashing and then fixed illumination of the under-inflation warning lamp accompanied by the illumination of the service warning lamp indicates a fault with the system.

In this case, monitoring of the tyre pressures is not assured.



This alert is also displayed when one or more wheels is not fitted with a sensor (for example, a space-saver or steel spare wheel).

Go to a CITROËN dealer or a qualified workshop to have the system checked or, following the repair of a puncture, to have the original wheel, equipped with a sensor, refitted.

Any tyre repair or replacement on a wheel fitted with this system must be carried out by a CITROËN dealer or a qualified workshop. If after changing a tyre, a wheel is not detected by your vehicle (fitting snow tyres for example), you must have the system reinitialised by a CITROËN dealer or a qualified workshop.

# Stop & Start

The Stop & Start system puts the engine temporarily into standby - STOP mode - during stops in the traffic (red lights, traffic jams, ...). The engine restarts automatically - START mode - as soon as you want to move off. The restart takes place instantly, quickly and silently.

Perfect for urban use, the Stop & Start system reduces fuel consumption and exhaust emissions as well as the noise level when stationary.

## Operation

### Going into engine STOP mode



The "ECO" warning lamp comes on in the instrument panel and the engine goes into standby automatically:

- **with a manual gearbox**, at speeds below 12 mph (20 km/h) or vehicle stationary with the THP 120 petrol and BlueHDi 115 and 120 Diesel versions, when you place the gear lever in neutral and you release the clutch pedal,
- **with an automatic gearbox**, vehicle stationary, when you press the brake pedal or put the gear selector in position **N**.



If your vehicle is fitted with the system, a time counter calculates the sum of the periods in STOP mode during a journey. It resets itself to zero every time the ignition is switched on with the **START/STOP** button.



For your comfort, during parking manoeuvres, STOP mode is not available for a few seconds after coming out of reverse gear. Stop & Start does not affect the operation of vehicle systems such as braking, power steering...



Never refuel with the engine in STOP mode; you must switch off the ignition with the **START/STOP** button.



## Special cases: STOP mode not available

STOP mode is not invoked when:

- the vehicle is on a steep slope (rising or falling),
- the driver's door is open,
- the driver's seat belt is not fastened,
- the vehicle has not exceeded 6 mph (10 km/h) since the last engine start using the **START/STOP** button,
- the electric parking brake is applied or being applied,
- the engine is needed to maintain a comfortable temperature in the passenger compartment,
- demisting is active,
- some special conditions (battery charge, engine temperature, braking assistance, ambient temperature...) where the engine is needed to assure control of a system.



In this case, the "ECO" warning lamp flashes for a few seconds then goes off.

**This operation is perfectly normal.**

## Going into engine START mode

**ECO** The "ECO" warning lamp goes off and the engine starts automatically:

- **with a manual gearbox**, when you **fully** depress the clutch pedal,
- **with an automatic gearbox**:
  - gear selector in position **D** or **M**, when you release the brake pedal,
  - or gear selector in position **N** and brake pedal released, when you place the gear selector in position **D** or **M**,
  - or when you engage reverse.

## Special cases: START invoked automatically

As a safety measure or to maintain comfort levels in the vehicle, START mode is invoked automatically when:

- you open the driver's door,
- you unfasten the driver's seat belt,
- the speed of the vehicle exceeds 15 mph (25 km/h) with a manual gearbox (2 mph (3 km/h) with THP 210 petrol and BlueHDi 115 and 120 Diesel versions), or 2 mph (3 km/h) with an automatic gearbox,
- the electric parking brake is being applied,
- some special conditions (battery charge, engine temperature, braking assistance, ambient temperature...) where the engine is needed for control of a system.



In this case the "ECO" warning lamp flashes for a few seconds, then goes off.

**This operation is perfectly normal.**

## Deactivation / Reactivation

In certain circumstances, such as the need to maintain the temperature in the passenger compartment, it may be useful to deactivate the Stop & Start system.

The system can be deactivated at any time, once the ignition is switched on.

If the engine is in STOP mode, it then restarts.

The Stop & Start system is reactivated automatically every time the ignition is switched on.

### Opening the bonnet



Before doing anything under the bonnet, deactivate the Stop & Start system to avoid the risk of injury related to an automatic change to START mode.

### Driving on flooded roads

Before driving through a flooded road, it is strongly recommended that you deactivate the Stop & Start system. For more advice on driving, particularly on flooded roads, refer to the corresponding section.

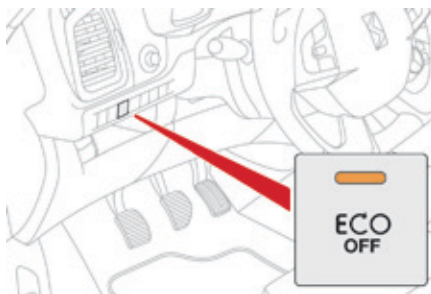

### With the switch on the dashboard

Press this switch. Deactivation is confirmed by the illumination of the indicator lamp in the control switch and the display of a message.

Pressing the switch again reactivates the system. The indicator lamp in the switch goes off, accompanied by the display of a message.

### With the touch screen button

Select the "Driving" menu. In the page, press this button.

Deactivation is confirmed by the illumination of the indicator lamp for the button and the display of a message.

Pressing the button again reactivates the system. The indicator lamp for the button goes off, accompanied by the display of a message.



## Operating fault

In the event of a fault with the system, the button in the "**ECO OFF**" switch flashes for a few moments, then remains on.  
Have it checked by a CITROËN dealer or a qualified workshop.

In the event of a fault in STOP mode, the vehicle may stall.

All of the instrument panel warning lamps come on.

It is then necessary to switch off the ignition and start the engine again using the "**START/STOP**" button.



The Stop & Start system requires a 12 V battery of specific technology and specification.

All work on this type of battery must be carried out only by a CITROËN dealer or a qualified workshop.

For more information on the 12 V battery, refer to the corresponding section.

# Lane departure warning system

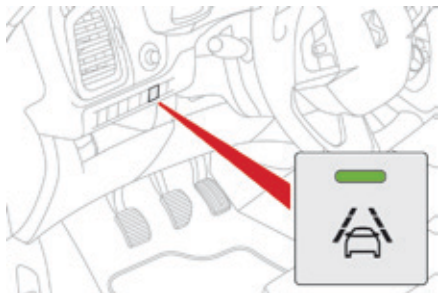

System which, using a camera which recognises solid or broken lines, detects the involuntary crossing of longitudinal traffic lane markings on the ground.

To provide safe driving, the camera analyses the image then, if the driver's attention drops, triggers a warning if the vehicle drifts over a lane marking (speed higher than 50 mph (80 km/h)).

This system is particularly useful on motorways and main roads.



The lane departure warning system cannot, in any circumstances replace the need for vigilance on the part of the driver.

## Activation



When switching on the ignition or with the engine running, press this button to activate the system; the indicator lamp comes on.

## Detection - Alert

You are warned by the vibration of the driver's seat cushion:

- on the right-hand side, if the marking on the ground has been crossed on the right,
- on the left-hand side, if the marking on the ground has been crossed on the left.

No warning is transmitted while the direction indicator is active and for approximately 20 seconds after the direction indicator is switched off.

## Deactivation



Press this button again, the indicator lamp goes off.

The status of the system remains in the memory when the ignition is switched off.

## Operating fault

In the event of a fault, the indicator lamp in the button flashes.

Contact a CITROËN dealer or a qualified workshop.



The detection may be impeded:

- if the markings on the ground are worn,
- if there is little contrast between the markings on the ground and the road surface,
- if the windscreen is dirty,
- in certain severe weather conditions: fog, heavy rain, snow, bright sunlight or direct exposure to the sun (low sun, leaving a tunnel, ...) and shade.



It is necessary to observe the driving regulations and to take a break every two hours.

# Blind spot sensors

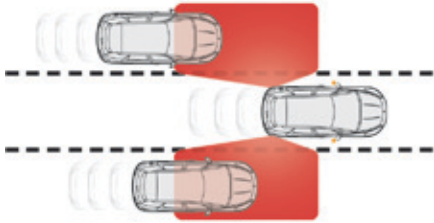

This driving assistance system warns the driver of the presence of another vehicle in the blind spot angle of their vehicle (areas masked from the driver's field of vision), as soon as this presents a potential danger.

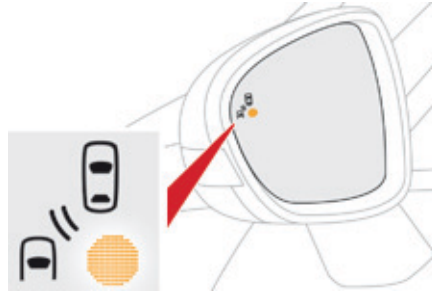

A warning lamp appears in the door mirror on the side in question:

- immediately, when being overtaken,
- after a delay of about one second, when overtaking a vehicle slowly.

## Operation

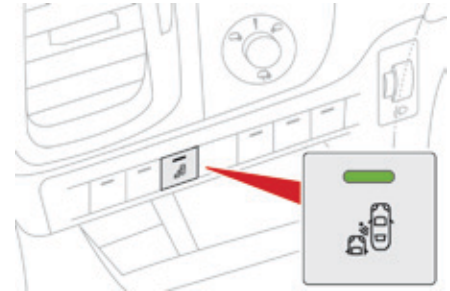

- ☞ On switching on the ignition, or engine running, press this button to activate the function; the warning lamp comes on. Sensors fitted in the front and rear bumpers monitor the blind spots.

**!** This system is designed to improve safety when driving and is in no circumstances a substitute for the use of the interior rear view mirror and door mirrors. It is the driver's responsibility to constantly check the traffic, to assess the distances and relative speeds of other vehicles and to predict their movements before deciding whether to change lane. The blind spot sensor system can never replace the need for vigilance on the part of the driver.

The alert is given by a warning lamp which comes on in the door mirror on the side in question as soon as a vehicle - car, lorry, cycle - is detected.

For this, the following conditions must be met:

- all the vehicles must be moving in the same direction,
- the speed of your vehicle is between 7 and 75 mph (12 and 140 km/h),
- when you overtake a vehicle with a speed difference of less than 6 mph (10 km/h),
- when a vehicle overtakes you with a speed difference of less than 15 mph (25 km/h),
- the traffic must be flowing normally,
- in the case of an overtaking manoeuvre, if this is prolonged and the vehicle being overtaken remains in the blind spot,
- you are driving on a straight or slightly curved road,
- your vehicle is not pulling a trailer, a caravan...

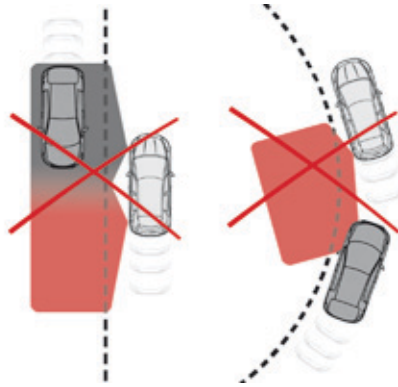

No alert will be given in the following situations:

- in the presence of immobile objects (parked vehicles, barriers, street lamps, road signs...),
- with vehicles moving in the opposite direction,
- driving on a sinuous road or a sharp corner,

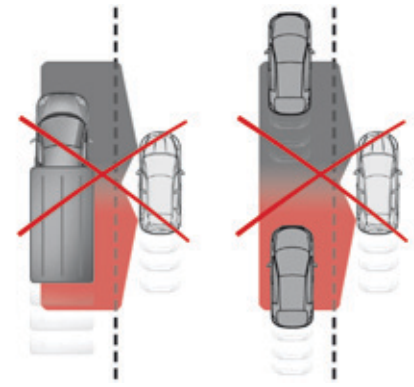

- when overtaking (or being overtaken by) a very long vehicle (lorry, coach...) which is at the same time detected at the rear in the blind spot angle and present in the driver's forward field of vision,
- in very heavy traffic: vehicles detected in front and behind are confused with a lorry or a stationary object,
- when overtaking quickly.

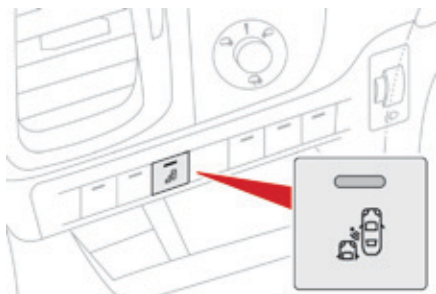

☞ To deactivate the system, press this button again; the warning lamp goes off.

The state of the system remains in memory on switching off the ignition.

**i** The system is automatically deactivated when towing with a towbar approved by CITROËN.

## Operating fault

In the event of a fault, the warning lamp in the button flashes then goes off.  
Have it checked by a CITROËN dealer or a qualified workshop.

**i** The system may suffer temporary interference in certain weather conditions (rain, hail...).  
In particular, driving on a wet surface or moving from a dry area to a wet area can cause false alerts (for example, the presence of a fog of water droplets in the blind spot angle is interpreted as a vehicle).  
In bad or wintry weather, ensure that the sensors are not covered by mud, ice or snow.  
Take care not to cover the warning zone in the door mirrors or the detection zones on the front and rear bumpers with adhesive labels or other objects; they may hamper the correct operation of the system.

# Head-up display

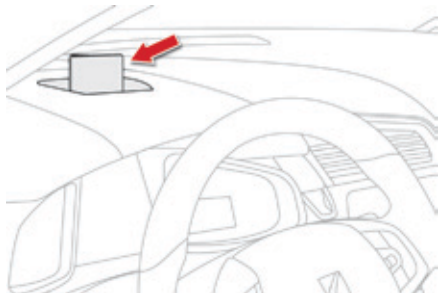

System which projects information onto a transparent blade in the driver's field of vision so that they do not have to take their eyes off the road. This system operates when the engine is running and the settings are stored when the ignition is switched off.

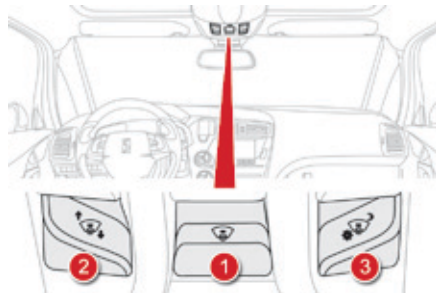
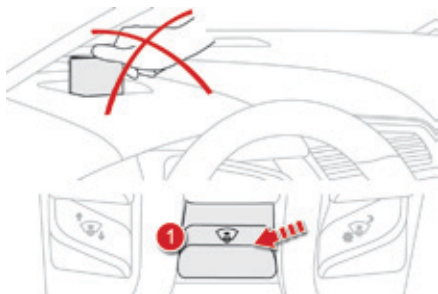

1. Head-up display On / Off.
2. Display height adjustment.
3. Brightness adjustment.

## Displays during operation

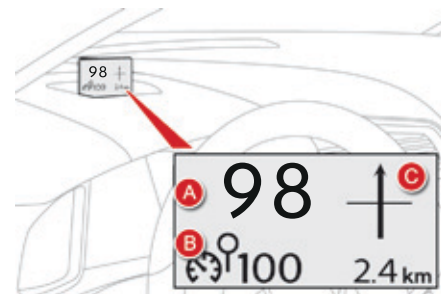

Once the system has been activated, the information projected in the head-up display is:

- A. The speed of your vehicle.
- B. Cruise control/speed limiter information.
- C. Navigation information (depending on version).

 For more information on the navigation system, refer to the "Audio and telematics" section.



## Activation / Deactivation

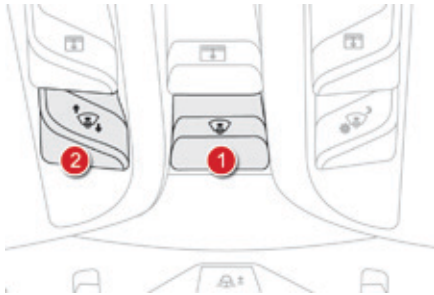

- ☞ With the engine running, press button 1. The activated/deactivated status when the engine was switched off is retained when the engine is switched on again.

The blade retracts automatically 3 seconds after switching off the engine except in STOP mode of Stop & Start.

## Height adjustment

- ☞ With the engine running, adjust the display to the required height using button 2:
- towards the rear to move the display up,
  - towards the front to move the display down.

## Brightness adjustment



- ☞ With the engine running, adjust the brightness of the information using button 3:
- towards the rear to increase the brightness,
  - towards the front to decrease the brightness.



We recommend that adjustments are only made using these buttons when the vehicle is stationary. When stationary or while driving, no objects should be placed around the transparent blade (or on its cover) to avoid blocking deployment of the blade and preventing its correct operation.



In certain extreme weather conditions (rain and/or snow, bright sunshine, ...) the head-up display may not be legible or may suffer temporary interference. Some sunglasses may hamper reading of the information.

To clean the transparent blade, use a clean, soft cloth (such as a spectacles cloth or microfibre cloth). Do not use a dry or abrasive cloth or detergent or solvent products as these could scratch the blade or damage the anti-reflection coating.

# Memorising speeds

By offering preset speed settings, this function facilitates the programming of a speed setting for both the speed limiter and the cruise control.

The system includes up to 5 or 6 speeds, depending on equipment, that you can modify.

## With your Audio system



### Activating the function Modifying a speed setting

- ☞ Go to the main menu by pressing the **"MENU"** button:
- ☞ Select the "Personalisation-configuration" menu and confirm.
- ☞ Select "Vehicle parameters" menu and confirm.
- ☞ Select the "Driving assistance" line and confirm.
- ☞ Select "Speeds memorised" line and confirm.
- ☞ Select "Activation" to activate the function.

- ☞ Select the speed setting to be modified and confirm.
- ☞ Modify the speed setting.
- ☞ Select **"OK"** and confirm to save the modifications.



As a safety measure, the driver must only modify the speed settings when stationary.



### **"MEM" button**

- ☞ Press this button to display the list of memorised speed settings.

## With the touch screen

### Modifying a speed setting

**DRIVE** ☞ Press this button to select the "Driving" menu.



☞ Press "**Speed settings**".

☞ Select the system for which you want to memorise new speed settings:



- speed limiter

or



- cruise control

☞ Choose the speed setting to be modified.



- ☞ Enter the new value using the numerical keypad and confirm.
- ☞ Confirm to save the modification and quit the menu.



### "MEM" button

This button allows you to select a speed setting to be used with the speed limiter or cruise control.

Refer to the corresponding section.

# Speed limiter

System which prevents the vehicle from exceeding the speed programmed by the driver.

- i** The speed limiter is **switched on** manually. The minimum programmed speed is 20 mph (30 km/h). The programmed speed remains in the system memory when the ignition is switched off.

## Steering mounted controls

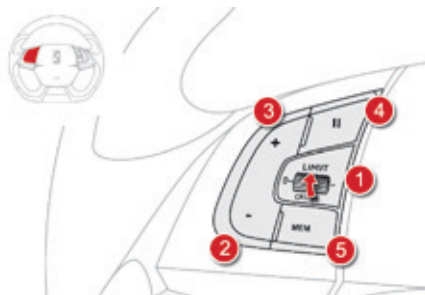

1. Speed limiter mode selection wheel.
2. Programmed value decrease button.
3. Programmed value increase button.
4. Speed limiter on / pause button.
5. Display memorised speed settings button.

## Displays in the instrument panel

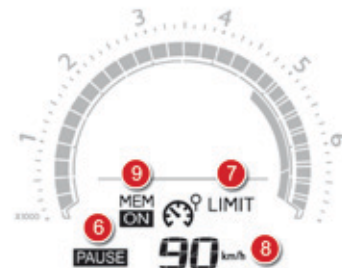

6. Speed limiter on / pause indication.
7. Speed limiter mode selection indication.
8. Programmed speed value.
9. Selection of a memorised speed setting.

- H** The speed limiter is a driving aid that cannot, in any circumstances, replace the need to observe speed limits or the need for vigilance on the part of the driver.



- i** This information also appears in the head-up display. For more information, refer to the "Head-up display" section.

## Switching on



- ☞ Turn the wheel **1** to the "LIMIT" position to select the speed limiter; the function is paused.



- ☞ If the speed setting is suitable (last speed setting programmed in the system) press button **4** to switch the speed limiter on.



- ☞ Pressing button **4** temporarily interrupts the function (pause).

## Adjusting the limit speed setting

You do not have to switch the speed limiter on in order to set the speed.

To modify the limit speed setting using memorised speeds and from your Audio system:

- ☞ with the system first activated.
- For more information on memorising speeds, refer to the corresponding section.
- ☞ make a long press on button **2** or **3**, the system displays the memorised speed closest to the actual speed of the vehicle; this setting becomes the new limit speed,
- ☞ to choose another memorised speed, make another long press on button **2** or **3**.

To modify the limit speed setting using memorised speeds and from the touch screen:

- ☞ press button **5** to display the six memorised speed settings,
- ☞ press the button for the desired speed setting.

This setting becomes the new limit speed.

To modify the limit speed setting from the current speed of the vehicle:

- ☞ in steps of +/- 1 mph (km/h), make successive short presses on button **2** or **3**,
- ☞ continuously, in steps of +/- 5 mph (km/h), press and hold button **2** or **3**.

## Temporarily exceeding the programmed speed

- ☞ If you want to temporarily exceed the programmed limit speed, press **firmly** on the accelerator pedal, going beyond the **point of resistance**.

The speed limiter is deactivated temporarily and the displayed programmed speed flashes.



- ⚠ On a steep descent or in the event of sharp acceleration, the speed limiter will not be able to prevent the vehicle from exceeding the programmed speed.

When the limit speed is exceeded but is not due to action by the driver, there is an audible signal to complete the alert.

Once the speed of the vehicle returns to the programmed setting, the speed limiter functions again: the display of the programmed speed setting becomes steady again.



## Switching off

- ☞ Turn wheel 1 to the "0" position: the display of information on the speed limiter disappears.

## Operating fault

Flashing dashes indicate a fault with the speed limiter.



Have it checked by a CITROËN dealer or a qualified workshop.

- ⚠ The use of mats not approved by CITROËN may interfere with the operation of the speed limiter. To avoid any risk of jamming of the pedals:
  - ensure that the mat is positioned correctly,
  - do not fit one mat on top of another.

# Cruise control

System which automatically maintains the cruising speed of the vehicle at a setting programmed by the driver, without any action on the accelerator pedal.

- i** The cruise control is **switched on** manually.  
It requires a minimum vehicle speed of 25 mph (40 km/h) as well as:
- with a manual gearbox, the engagement of fourth gear or higher,
  - with an automatic gearbox, the gear selector at position **D** or second gear or higher in manual mode.

- The operation of the cruise control can be interrupted (pause):
- by pressing control **4** or by pressing the brake or clutch pedal,
  - automatically, if operation of the dynamic stability control system is triggered.

- i** Switching off the ignition cancels any programmed speed setting.

- !** As a safety measure, you are advised to keep your feet near the pedals at all times.

## Steering mounted controls

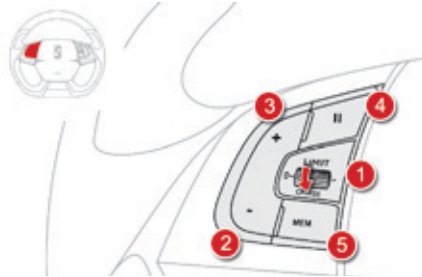

1. Cruise control mode selection wheel.
2. Button for setting the current speed of the vehicle as the cruise setting or lowering the cruise setting.
3. Button for setting the current speed of the vehicle as the cruise setting or raising the cruise setting.
4. Cruise control pause / resume button.
5. Display memorised speed settings button.

- !** The cruise control system is a driving aid that cannot, in any circumstances, replace the need to observe speed limits, nor the need for vigilance on the part of the driver.

## Displays in the instrument panel

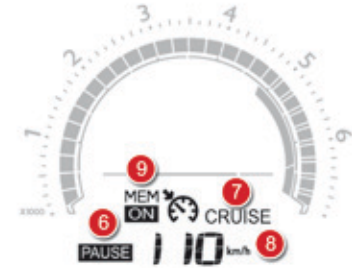

6. Cruise control pause / resume indication.
7. Cruise control mode selected indication.
8. Cruise speed setting.
9. Selecting a memorised cruise speed.

108  
110 II

- i** This information also appears in the head-up display.  
For more information, refer to the "Head-up display" section.

## Switching on



- ☞ Turn the wheel **1** to the "**CRUISE**" position to select cruise control mode; the function is paused.

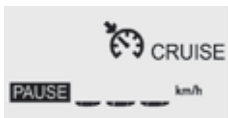

- ☞ To start the cruise control and set a cruise speed, once the vehicle has reached the desired speed, press button **2** or **3**: the current speed of your vehicle becomes the cruise speed setting. You can release the accelerator pedal.



- ☞ Pressing button **4** interrupts operation of the system (pause).



- ☞ Pressing button **4** again restores operation of the cruise control (ON).

## Adjusting the cruise speed setting

The cruise control must be activated.

To modify the cruise speed setting using memorised speeds and from your Audio system:

- ☞ with the system first activated.
- For more information on memorising speeds, refer to the corresponding section.
- ☞ make a long press on button **2** or **3**, the system displays the memorised speed closest to the actual speed of the vehicle; this setting becomes the new cruise speed,
- ☞ to choose another memorised speed, make another long press on button **2** or **3**.

To modify the cruise speed setting using memorised speeds and from the touch screen:

- ☞ press button **5** to display the six memorised speed settings,
- ☞ press the button for the desired speed setting.

This setting becomes the new cruise speed.

 As a precaution, it is recommended that the cruise speed chosen be close to the current speed of your vehicle, so as to avoid any sudden acceleration or deceleration of the vehicle.

To modify the cruise speed setting from the current speed of the vehicle:

- ☞ in steps of + or - 1 mph (km/h), make repeated short presses on button **2** or **3**,
- ☞ continuously, in steps of + or - 5 mph (km/h), press and hold button **2** or **3**.

 Take care: pressing and holding button **2** or **3** results in a rapid change in the speed of your vehicle.



## Temporarily exceeding the programmed speed

When required (overtaking manoeuvre...), it is possible to exceed the programmed speed by pressing the accelerator pedal.

The cruise control is temporarily overridden and the programmed speed setting flashes.



To return to the programmed speed, simply release the accelerator pedal.

Once the vehicle has returned to the programmed speed, the cruise control takes over again: the display of the programmed speed setting becomes steady again.



**!** When descending a steep hill, the cruise control system cannot prevent the vehicle from exceeding the programmed speed.

You may have to brake to control the speed of your vehicle. In this case, the cruise control is automatically paused.

To activate the system again, press button **4**.

## Switching off

☞ Turn wheel **1** to the "0" position: the cruise control information disappears from the screen.

## Operating fault

Flashing dashes indicate a fault with the cruise control system.



Have it checked by a CITROËN dealer or a qualified workshop.

**!** Only use the cruise control if the traffic conditions will allow you to drive for a certain time at a steady speed and at a safe distance from the vehicle ahead. Do not activate the cruise control in urban areas, in heavy traffic, on winding or steep roads, on slippery or flooded roads, or in conditions of poor visibility (heavy rain, fog, falling snow...). In some circumstances, it may not be possible to maintain or reach the programmed speed: towing, vehicle heavily loaded, steep climb.

**!** The use of mats not approved by CITROËN may interfere with the operation of the cruise control. To avoid any risk of jamming of the pedals:

- ensure that the mat is positioned correctly,
- never fit one mat on top of another.

# Parking sensors

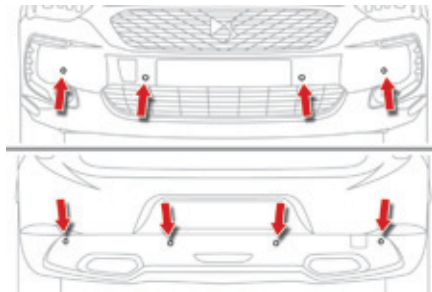

This system indicates the proximity of an obstacle (person, vehicle, tree, gate, etc.) which comes within the field of detection of sensors located in the bumper. Certain types of obstacle (stake, roadworks cone, etc.) detected initially will no longer be detected at the end of the manoeuvre, if they are located in blind spots in the sensors' field of detection.



This system cannot in any circumstances replace the need for vigilance on the part of the driver.

## Rear parking sensors

The system is switched on by engaging reverse gear.

This is confirmed by an audible signal.

The system is switched off when you come out of reverse gear.

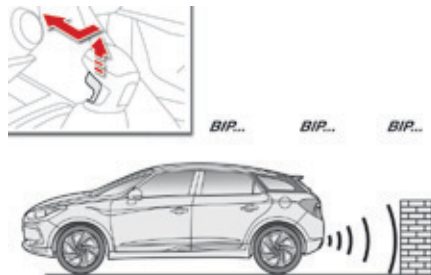

## Audible assistance

The proximity information is given by an intermittent audible signal, the frequency of which increases as the vehicle approaches the obstacle. The sound emitted by the speaker (right or left) indicates the side on which the obstacle is located. When the distance between the vehicle and the obstacle becomes less than approximately thirty centimetres, the audible signal becomes continuous.

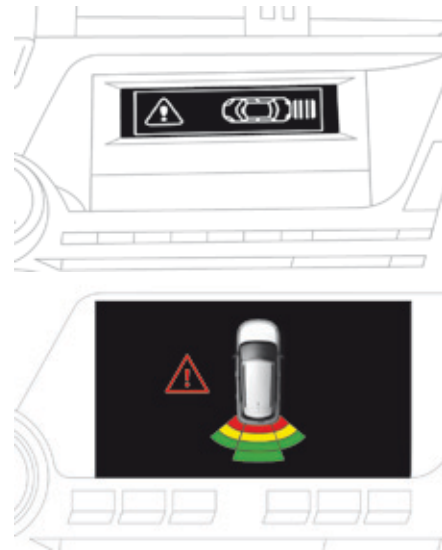

## Visual assistance

This supplements the audible signal by displaying bars in the screen which move progressively nearer to the vehicle. When the obstacle is very close, the "Danger" symbol is displayed on the screen.

## Front parking sensors

In addition to the rear parking sensors, the front parking sensors are triggered when an obstacle is detected in front and the speed of the vehicle is still below 6 mph (10 km/h).

The front parking sensors are interrupted if the vehicle stops for more than three seconds in forward gear, if no further obstacles are detected or when the speed of the vehicle exceeds 6 mph (10 km/h).

- i** The sound emitted by the speaker (front or rear) indicates whether the obstacle is in front or behind.

## Deactivation / Activation of the front and rear parking sensors

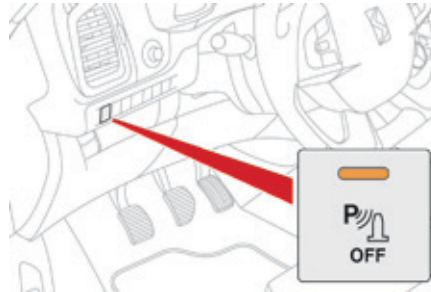

The function is deactivated by pressing this button. The indicator lamp in the button comes on.

Pressing this button again reactivates the function. The indicator lamp in the button goes off.

- i** The function will be deactivated automatically if a trailer is being towed or a bicycle carrier is fitted (vehicle fitted with a towbar or bicycle carrier recommended by CITROËN).

## Operating fault

**SERVICE** In the event of a malfunction of the system, when reverse gear is engaged this warning lamp is displayed in the instrument panel and/or a message appears in the screen, accompanied by an audible signal (short beep).

Contact a CITROËN dealer or a qualified workshop.

- i** In bad weather or in winter, ensure that the sensors are not covered with mud, ice or snow. When reverse gear is engaged, an audible signal (long beep) indicates that the sensors may be dirty. Certain sound sources (motorcycle, lorry, pneumatic drill, etc.) may trigger the audible signals of the parking sensor system.

# Reversing camera

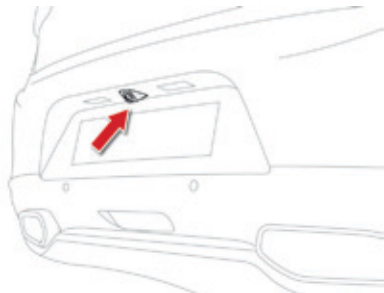

The reversing camera is activated automatically when reverse gear is engaged. The image from the camera is displayed in the touch screen.

The reversing camera system may be accompanied by parking sensors.

 This system is a driving aid that does not replace vigilance on the part of the driver, who must remain in control of the vehicle at all times.

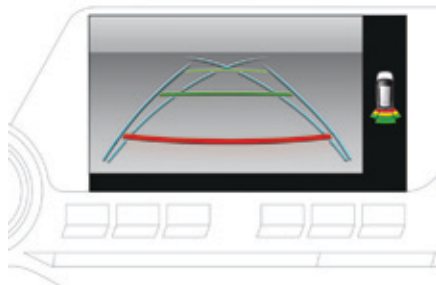

The blue lines represent the general direction of the vehicle. The blue curved lines represent the maximum turning circle.

The green lines represent distances of around 1 to 2 metres beyond the edge of the vehicle's rear bumper.

The red line represents the distance of around 30 cm beyond the edge of your vehicle's rear bumper.

 The lines displayed in the screen do not allow the position of the vehicle to be determined relative to tall obstacles (for example: vehicles nearby). Some deformation of the image is normal.

## High pressure jet washing

When cleaning your vehicle, keep the end of the high pressure lance at least 30 cm from the camera lens. Clean the camera lens regularly using a soft cloth.



**005**

Visibility



# Lighting controls

Controls for selection and operation of the various front and rear lamps providing the vehicle's lighting and signalling.

## Main lighting

There are various lamps on the vehicle:

- sidelamps, to be seen,
- dipped beam headlamps to see without dazzling other drivers,
- main beam headlamps to see clearly when the road is clear,
- directional headlamps for improved visibility when cornering.

## Additional lighting

Other lamps are installed to fulfil the requirements of particular driving conditions:

- rear foglamps to better signal the presence of the vehicle in foggy conditions,
- front foglamps for better visibility in foggy conditions and to improve lighting at intersections and when parking,
- daytime running lamps for better visibility of the vehicle by day.

## Lighting function settings

You can activate or deactivate the following lighting functions:

- guide-me-home lighting,
- main additional lighting,
- secondary additional lighting,
- welcome lighting,
- automatic illumination of headlamps,
- automatic headlamp dipping.









## Selection ring for main lighting mode

Turn the ring to align the desired symbol with the marking.



-  Lighting off (ignition off) / Daytime running lamps (engine running).
-  Automatic illumination of headlamps.
-  Sidelamps only.
-  Dipped or main beam headlamps.

## Dipping the headlamps

Pull the stalk to switch the lighting between dipped / main beam headlamps.

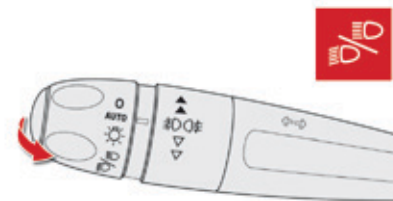

In the lighting off and sidelamps modes, the driver can switch on the main beam headlamps temporarily ("headlamp flash") by maintaining a pull on the stalk.

## Displays

Illumination of the corresponding indicator lamp in the instrument panel confirms the lighting switched on.

## Foglamp selection ring

The foglamps operate with dipped and main beam headlamps.

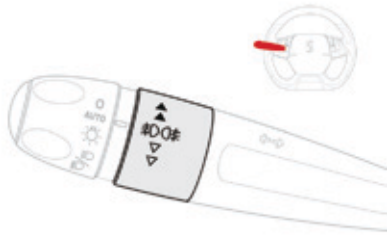

### Front and rear foglamps

Rotate and release the ring:

- ☞ forwards a first time to switch on the front foglamps,
- ☞ forwards a second time to switch on the rear foglamps,
- ☞ rearwards a first time to switch off the rear foglamps,
- ☞ rearwards a second time to switch of the front fog lamps.

When the headlamps switch off with automatic illumination of headlamps (AUTO model) or when the dipped beam headlamps are switched off manually, the foglamps and sidelamps remain on.

- ☞ Turn the ring rearwards to switch off the foglamps, the sidelamps will then switch off.



In good or rainy weather, by both day and night, the front foglamps and the rear foglamps are prohibited. In these situations, the power of their beams may dazzle other drivers. They should only be used in fog or falling snow. In these weather conditions, you should switch on the foglamps and dipped beam headlamps manually, as the sunshine sensor may detect sufficient light. Do not forget to switch off the front and rear foglamps when they are no longer necessary.

### **i** Switching off the lighting when switching off the ignition

When the ignition is switched off, all of the lamps switch off immediately, except for the dipped beam headlamps if automatic guide-me-home lighting is activated.

### **Switching on the lighting when switching on the ignition**

To reactivate the lighting control stalk, turn the ring **A** to position **"0"** - lighting off, then to the position of your choice. When the driver's door is opened, a temporary audible signal warns you that the vehicle's lighting is on.

They switch off automatically after a period which depends on the state of charge of the battery (entry to energy economy mode).

**i** In some weather conditions (e.g. low temperature or humidity), the presence of misting on the internal surface of the glass of the headlamps and rear lamps is normal; it disappears after the lamps have been on for a few minutes.

## **Daytime running lamps / Sidelamps (LEDs)**

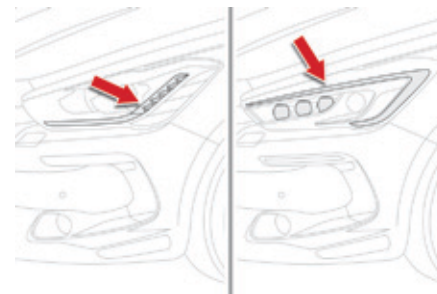

The light-emitting diodes (LEDs) come on automatically when the engine is started.

They provide the following functions:

- Daytime running lamps (lighting control stalk in position **"0"** or **"AUTO"** with adequate light level).
- Sidelamps (lighting control stalk in position **"AUTO"** with low light level or "Sidelamps only" or "Main or dipped beam headlamps").

The LEDs are brighter when operating as daytime running lamps.

# Automatic illumination of headlamps

When a low level of ambient light is detected by a sunshine sensor, the number plate lamps, sidelamps and dipped beam headlamps are switched on automatically, without any action on the part of the driver. They can also come on if rain is detected, at the same time as automatic operation of the windscreen wipers. As soon as the ambient light returns to a sufficient level or after the windscreen wipers are switched off, the lamps are switched off automatically.

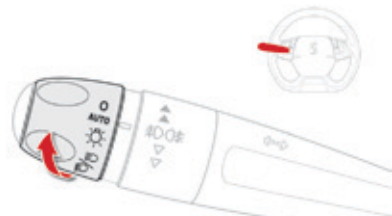

## Activation

- ☞ Turn the ring to the "AUTO" position. The activation of the function is accompanied by the display of a message in the screen.

## Deactivation

- ☞ Turn the ring to another position. Deactivation of the function is accompanied by the display of a message in the screen.

## Operating fault

- SERVICE** In the event of a malfunction of the sunshine sensor, the lighting comes on, this warning lamp is displayed in the instrument panel and/or a message appears in the screen, accompanied by an audible signal.

Contact a CITROËN dealer or a qualified workshop.

- ⚠ In fog or snow, the sunshine sensor may detect sufficient light. In this case, the lighting will not come on automatically. Do not cover the sunshine sensor, coupled with the rain sensor and located in the centre of the windscreen behind the rear view mirror; the associated functions would no longer be controlled.

## Automatic guide-me-home lighting

When the automatic illumination of headlamps function is activated (lighting control stalk in the "AUTO" position), under low ambient light the dipped beam headlamps remain on when the ignition is switched off.

## Programming



Activation or deactivation, as well as the duration of the guide-me-home lighting, is set in the vehicle configuration menu.

## Automatic headlamp dipping

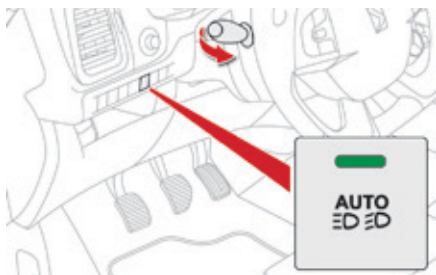

System which automatically changes between dipped and main beam according to the lighting and traffic conditions, using a camera located in the rear view mirror.

**!** This automatic headlamp dipping system is a driving aid. The driver remains responsible for the vehicle's lighting, its correct use for the prevailing conditions of light, visibility and traffic and observation of driving and vehicle regulations.

**i** The system will be operational as soon as you have exceeded 15 mph (25 km/h). If the speed drops below 9 mph (15 km/h), the system no longer operates.

### Switching on



☞ Put the lighting control stalk ring in the "AUTO" position.



☞ Press the button, its indicator lamp comes on.



☞ Flash the headlamps (pull the stalk beyond the point of resistance) to activate the function.



This indicator lamp comes on in the instrument panel to confirm activation.

### Operation

Once activated, the system operates as follows:

- if there is adequate light and/or if the traffic conditions do not allow the use of main beam, then dipped beam is maintained,
- if the light level is low and the traffic conditions allow, main beam comes on automatically.

### Pause

If the situation requires a change of headlamp beam, the driver can take over at any time.



☞ Flashing the headlamps again pauses the function and the lighting system changes to "automatic illumination of headlamps" mode.



☞ Flash the headlamps again to reactivate the system.

### Switching off



☞ Press the button, its indicator lamp goes off, the lighting system changes to "automatic illumination of headlamps" mode.



The system may suffer interference or not work correctly:

- under conditions of poor visibility (for example, snowfall, heavy rain or thick fog, ...),
- if the windscreen is dirty, misted or obscured (by a sticker, ...) in front of the camera,
- if the vehicle is facing highly reflective signs.

The system is not able to detect:

- road users that do not have their own lighting, such as pedestrians,
- road users whose lighting is obscured, such as vehicles running behind a safety barrier (on a motorway, for example),
- road users at the top or bottom of a steep slope, on twisty roads, on crossroads.

## Manual guide-me-home lighting

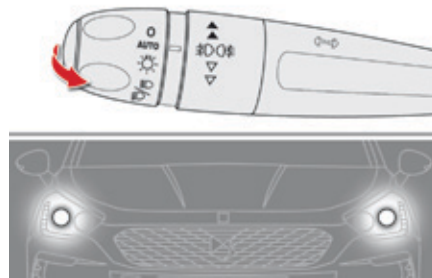

Temporarily keeping the dipped beam headlamps on after the vehicle's ignition has been switched off makes the exit of the vehicle's occupants easier when the light is poor.

### Switching on

- ☞ Within one minute after switching of the ignition, "flash" the headlamps using the lighting stalk.
- ☞ A further "headlamp flash" switches the function off.

### Switching off

The manual guide-me-home lighting switches off automatically after a set time (this time is programmable in the configuration menu).

## Parking lamps

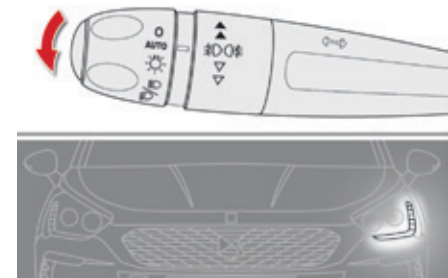

Side markers for the vehicle by illumination of the sidelamps on the traffic side only.

- ☞ Within one minute of switching off the ignition, operate the lighting control stalk up or down depending on the traffic side (for example: when parking on the left; lighting control stalk upwards; the right hand sidelamps are on).

This is confirmed by an audible signal and illumination of the corresponding direction indicator warning lamp in the instrument panel. To switch off the parking lamps, return the lighting control stalk to the middle position or switch on the ignition.

## Exterior welcome lighting

The remote control operation of the lighting makes your approach to the vehicle easier in poor light. It is activated according to the level of light detected by the sunshine sensor.

### Switching on



☞ Press the open padlock on the remote control or the door handle with the Keyless Entry and Starting system.

The dipped beam headlamps and the sidelamps come on; your vehicle is also unlocked.

### Switching off

The exterior welcome lighting switches off automatically after a set time, when the ignition is switched on or on locking the vehicle.

### Programming



The lighting duration is selected via the vehicle configuration menu.



The duration of the welcome lighting is associated with and identical to that of the automatic guide-me-home lighting.

## Door mirror spotlamps



To make your approach to the vehicle easier, these illuminate:

- the zones facing the driver's and passenger's doors,
- the zones forward of the door mirrors and rearward of the front doors.

### Switching on

The spotlamps come on:

- when you unlock the vehicle,
- when you switch off the ignition,
- when you open a door,
- when you use the remote control to locate the vehicle.

### Switching off

They are timed to go off automatically.

# Headlamp beam height adjustment

## Manual adjustment of halogen headlamps

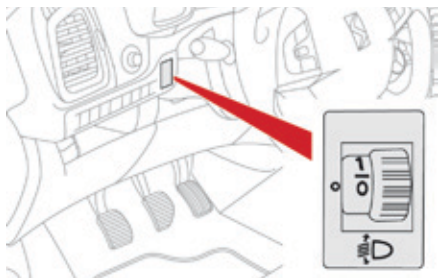

To avoid causing a nuisance to other road users, the height of the halogen headlamps should be adjusted according to the load in the vehicle.

0. 1 or 2 people in the front seats.
  - Intermediate setting.
1. 5 people + maximum authorised load.
  - Intermediate setting.
2. Driver + maximum authorised load.
  - Intermediate setting.
3. 5 people + maximum load in the boot.

## Automatic adjustment of xenon headlamps

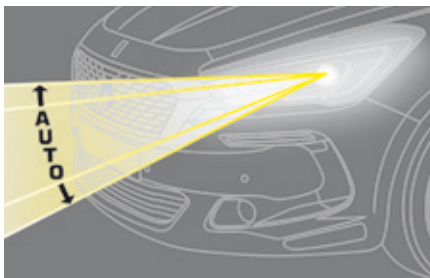

In order to avoid causing a nuisance to other road users, this system corrects the height of the xenon headlamps beam automatically and when stationary, in relation to the load in the vehicle.

**SERVICE** If a fault occurs, this warning lamp is displayed in the instrument panel, accompanied by an audible signal and a message in the instrument panel screen.

The system then places your headlamps in the lowest position.

 If a fault occurs, do not touch the xenon bulbs.  
Contact a CITROËN dealer or a qualified workshop.



The initial setting is position "0".



## Directional lighting

When the dipped or main beam headlamps are on, this function, allows the light beams to better follow the road.

The use of this function, coupled with the xenon headlamps and the cornering lighting, considerably improves the quality of your lighting round bends.

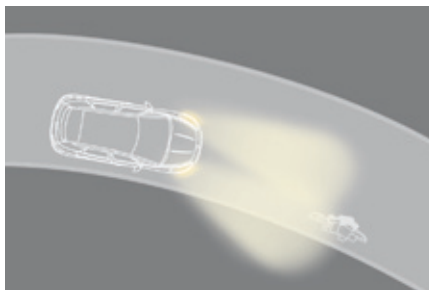

with directional lighting

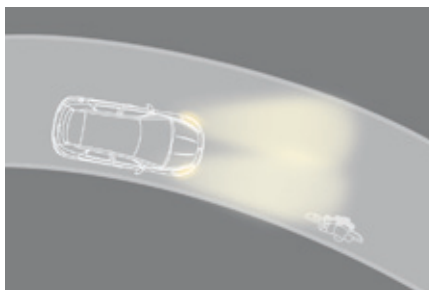

without directional lighting

### Programming



The system is activated or deactivated in the vehicle configuration menu.

The system is activated by default. The state of the system stays in memory on switching off the ignition.

### Operating fault



If a fault occurs, this warning lamp flashes in the instrument panel, accompanied by a message in the screen.

Contact a CITROËN dealer or a qualified workshop.



This function is inactive:

- when stationary or at low speeds,
- when reverse is engaged.

# Cornering lighting

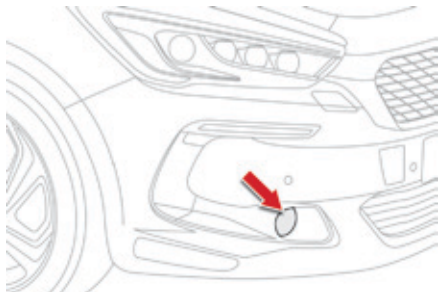

With dipped or main beams, this function makes use of the beam from a front foglamp to illuminate the inside of a bend, when the vehicle speed is below 25 mph (approximately 40 km/h) (urban driving, winding road, intersections, parking manoeuvres...).

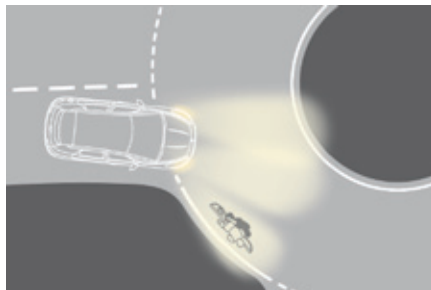

**with cornering lighting**

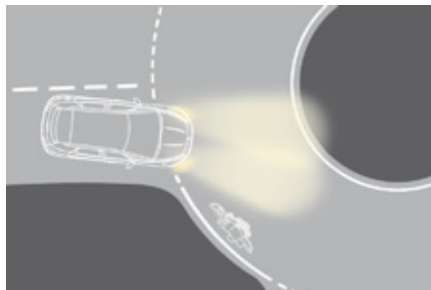

**without cornering lighting**

## Switching on

The system operates:

- when the corresponding direction indicator is switched on, or
- from a certain angle of rotation of the steering wheel.

## Switching off

The system does not operate:

- below a certain angle of rotation of the steering wheel,
- above 25 mph (40 km/h),
- when reverse gear is engaged.

## Programming



The system is activated or deactivated in the vehicle configuration menu.

The system is activated by default.

# Wiper controls

The vehicle's front and rear wipers are designed to improve the driver's visibility progressively according to the climatic conditions.

## Programming

Various automatic wiper control modes are also available according to the following options:

- automatic rain sensitive windscreen wipers,
- rear wiping on engaging reverse gear.

## Manual controls

The wipers are controlled directly by the driver.

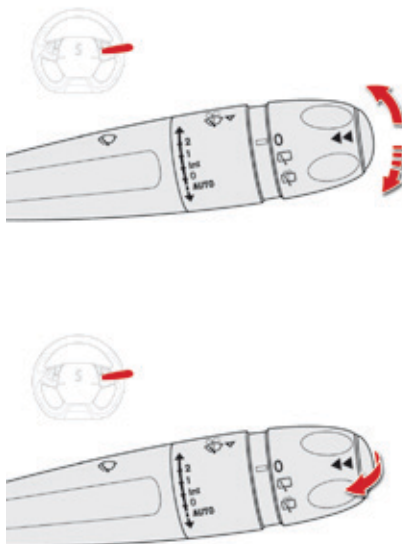

## Windscreen wipers

Wiping speed:

- |               |  |
|---------------|--|
| <b>2</b>      | fast (heavy rain),   |
| <b>1</b>      | normal (moderate rain),  |
| <b>Int</b>    | intermittent (proportional to the speed of the vehicle),                                 |
| <b>0</b>      | park,  |
| <b>AUTO ↓</b> | automatic (press down and release),<br>single wipe (pull the stalk briefly towards you). |

## Rear wiper

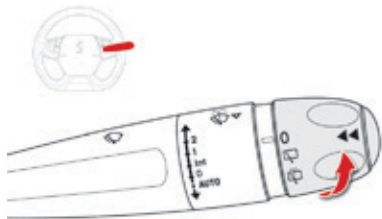

**!** If a significant accumulation of snow or ice is present, or when using a bicycle carrier on the boot, deactivate the automatic rear wiper via the configuration menu.

Rear wiper selection ring:



park,

intermittent wipe,

wash-wipe (set duration).

## Reverse gear

When reverse gear is engaged, the rear wiper will come into operation if the windscreen wipers are operating.

## Programming



The function is activated or deactivated via the configuration menu.

This function is activated by default.

## Windscreen and headlamp wash

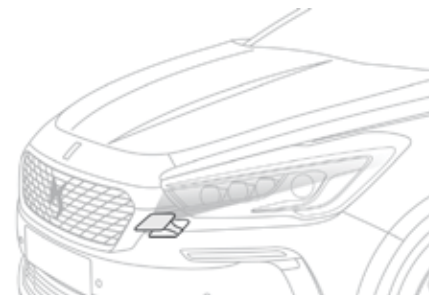

**!** Pull the windscreen wiper stalk towards you. The windscreen wash then the windscreen wipers operate for a fixed period.

The headlamp washers only operate when **the dipped or main beam headlamps are on, with the vehicle moving.**

To reduce the consumption of the fluid by the headlamp washers, they operate only with every seventh use of the screenwash or every 25 miles (40 km) during a given journey.



## Automatic rain sensitive windscreen wipers

The windscreen wipers operate automatically, without any action on the part of the driver, if rain is detected (sensor behind the rear view mirror), adapting their speed to the intensity of the rainfall.

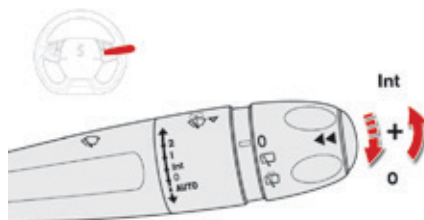
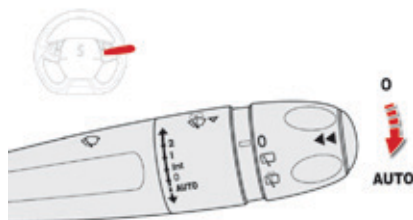

### Switching on



Briefly push the control stalk downwards.

A wiping cycle confirms that the instruction has been accepted.

This warning lamp comes on in the instrument panel and a message is displayed.

### Switching off



Briefly push the control stalk downwards again, or place the control stalk in another position (Int, 1 or 2).

This warning lamp goes off in the instrument panel and a message is displayed.



The automatic rain sensitive windscreen wipers must be reactivated by pushing the control stalk downwards, if the ignition has been off for more than one minute.

## Operating fault

If a fault occurs with the automatic rain sensitive wipers, the wipers will operate in intermittent mode.

Have it checked by CITROËN dealer or a qualified workshop.



Do not cover the rain sensor, linked with the sunshine sensor and located in the centre of the windscreen behind the rear view mirror.

Switch off the automatic rain sensitive wipers when using an automatic car wash.

In winter, it is advisable to wait until the windscreen is completely clear of ice before activating the automatic rain sensitive wipers.

## Special position of the windscreen wipers



This position permits release of the windscreen wiper blades.

It is used for cleaning or replacement of the blades. It can also be useful, in winter, to detach the blades from the windscreen.

- ☞ Any action on the wiper stalk in the minute after switching off the ignition places the blades vertically on the screen.
- ☞ To park the blades again, switch on the ignition and operate the wiper stalk.



To maintain the effectiveness of the flat wiper blades, it is advisable to:

- handle them with care,
- clean them regularly using soapy water,
- avoid using them to retain cardboard on the windscreen,
- replace them at the first signs of wear.

# Courtesy lamps

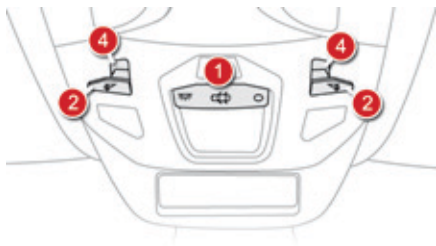

1. Front - rear courtesy lamp
2. Front map reading lamps
3. Rear map reading lamps
4. Interior mood LEDs

## Front - rear courtesy lamps



In this position, the courtesy lamp comes on gradually:

- when the vehicle is unlocked,
- when the electronic key is removed from the reader,
- when opening a door,
- when the remote control locking button is activated, in order to locate your vehicle.

It switches off gradually:

- when the vehicle is locked,
- when the ignition is switched on,
- 30 seconds after the last door is closed.



Permanently off.



Permanent lighting.



With the "permanent lighting" mode, the lighting time varies according to the circumstances:

- with the ignition off, approximately ten minutes,
- in energy economy mode, approximately thirty seconds,
- with the engine running, unlimited.

## Front - rear map reading lamps

- ☞ With the ignition on, press the corresponding switch.



Take care to avoid leaving anything in contact with the courtesy lamps.

## Interior mood lighting

The dimmed passenger compartment lighting improves visibility in the vehicle when the light is poor.

### Switching on



At night, the interior mood lighting comes on automatically when the sidelamps are switched on ( for example, a source of light in the roof console illuminates the middle of the centre console).

The interior mood lighting switches off automatically when the sidelamps are switched off.

### Programming



The system is activated and deactivated in the vehicle configuration menu.

### Adjusting the brightness of the courtesy lamp

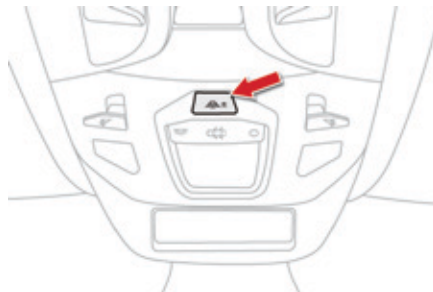

Lamps on: there are 7 levels of brightness.

The level of brightness increases progressively with each press of the button, returning to zero after the maximum level is reached.

A long press gives maximum brightness.

This adjustment is used to set the mood lighting level for the interior lamp, as well as for the door opening controls and the storage locations (depending on version).

## Footwell lighting



The soft lighting provided by the footwell lamps improves visibility in the vehicle when the light is poor.

### Switching on

Its operation is identical to that of the courtesy lamps. The lamps come on when one of the doors is opened.





**006**

Child safety



SOFIX

# General points relating to child seats

Although one of CITROËN main criteria when designing your vehicle, the safety of your children also depends on you.

For maximum safety, please observe the following recommendations:

- in accordance with European regulations, **all children under the age of 12 or less than one and a half metres tall must travel in approved child seats suited to their weight**, on seats fitted with a seat belt or ISOFIX mountings\*,
- **statistically, the safest seats in your vehicle for carrying children are the rear seats,**
- **a child weighing less than 9 kg must travel in the rearward facing position both in the front and in the rear.**



**CITROËN recommends** that children should travel in the **outer rear seats** of your vehicle:

- **rearward facing** up to the age of 3,
- **forward facing** over the age of 3.

\* The regulations on carrying children are specific to each country. Refer to the legislation in force in your country.

## Child seat at the front\*

### Rearward facing



When a rearward facing child seat is installed on the **front passenger seat**, adjust the seat to the fully back and highest position, with the backrest straightened.

The passenger's front airbag must be deactivated. Otherwise, **the child risks being seriously injured or killed if the airbag is deployed.**

### Forward facing



When a forward facing child seat is installed on the **front passenger seat**, adjust the vehicle's seat to the fully back and highest position with seat backrest straightened and leave the passenger's front airbag activated.



**Passenger seat in the fully back and highest position.**

- i** Ensure that the seat belt is correctly tensioned.  
For child seats with a support leg, ensure that the support leg is in firm and stable contact with the floor. If necessary, adjust the passenger seat.

\* Refer to the legislation in force in your country before carrying your child in this seating position.

# Deactivating the passenger's front airbag

 Never install a rearward facing child restraint system on a seat protected by an active front airbag. This could cause the death of the child or serious injury.

The warning label present on both sides of the passenger's sun visor repeats this advice. In line with current legislation, the following tables contain this warning in all of the languages required.

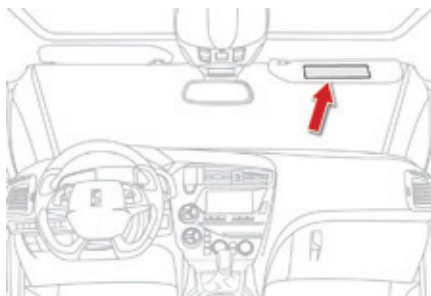

Passenger airbag OFF

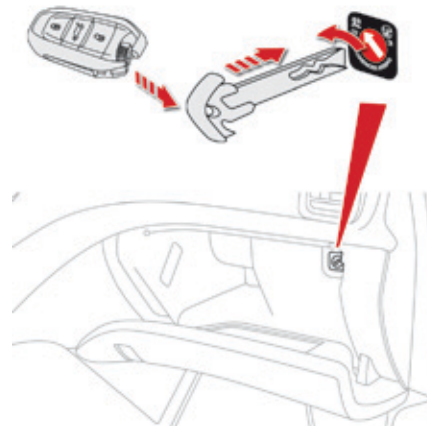

 For information on deactivating the passenger's front airbag, refer to the "Airbags" section.

AR	لا يجب أبدا تركيب نظام لإجلاس الطفل لوجه باتجاه الراء على مقعد سيارة مجهز بوسادة أمان هوائية أمامية مغلقة، فقد يؤدي هذا إلى التسبب بموت الطفل أو بإصابات خطيرة لديه.
BG	НИКОГА НЕ инсталирайте детско столче на седалка с АКТИВИРАНА предна ВЪЗДУШНА ВЪЗГЛАВНИЦА. Това може да причини СМЪРТ или СЕРИОЗНО НАРАНЯВАНЕ на детето.
CS	NIKDY neumistujte dětské zádržné zařízení orientované směrem dozadu na sedadlo chráněné AKTIVOVANÝM čelním AIRBAGEM. Hrozí nebezpečí SMRTI DÍTĚTE nebo VÁŽNĚHO ZRANĚNÍ.
DA	Brug ALDRIG en bagudvendt barnestol på et sæde, der er beskyttet af en AKTIV AIRBAG. BARNET risikerer at blive ALVORLIGT KVÆSTET eller DRÆBT.
DE	Montieren Sie auf einem Sitz mit AKTIVIERTEM Front-Airbag NIEMALS einen Kindersitz oder eine Babyschale entgegen der Fahrtrichtung, das Kind könnte schwere oder sogar tödliche Verletzungen erleiden.
EL	Μη χρησιμοποιείτε ΠΟΤΕ παιδικό κάθισμα με την πλάτη του προς το εμπρός μέρος του αυτοκινήτου, σε μια θέση που προστατεύεται από ΜΕΤΩΠΙΚΟ αερόσακο που είναι ΕΝΕΡΓΟΣ. Αυτό μπορεί να έχει σαν συνέπεια το ΘΑΝΑΤΟ ή το ΣΟΒΑΡΟ ΤΡΑΥΜΑΤΙΣΜΟ του ΠΑΙΔΙΟΥ
EN	NEVER use a rearward facing child restraint on a seat protected by an ACTIVE AIRBAG in front of it, DEATH or SERIOUS INJURY to the CHILD can occur
ES	NO INSTALAR NUNCA un sistema de retención para niños de espaldas al sentido de la marcha en un asiento protegido mediante un AIRBAG frontal ACTIVADO, ya que podría causar lesiones GRAVES o incluso la MUERTE del niño.
ET	Ärge MITTE KUNAGI paigaldage "seljaga sõidusuunas" lapseistet juhi kõrvalistmele, mille ESITURVAPADI on AKTIVEERITUD. Turvapadja avanemine võib last TÕSISELT või ELUOHTLIKULT vigastada.
FI	ÄLÄ KOSKAAN aseta lapsen turvaistuunta selkã ajosuuntaan istuimelle, jonka edessä suojana on käyttööön aktivoitu TURVATYÖNY. Sen laukeaminen voi aiheuttaa LAPSEN KUOLEMAN tai VAKAVAN LOUKKAANTUMISEN.
FR	NE JAMAIS installer de système de retenue pour enfants faisant face vers l'arrière sur un siège protégé par un COUSSIN GONFLABLE frontal ACTIVE. Cela peut provoquer la MORT de l'ENFANT ou le BLESSER GRAVEMENT
HR	NIKADA ne postavljati dječju sjedalicu leđima u smjeru vožnje na sjedalo zaštićeno UKLJUČENIM prednjim ZRAČNIM JASTUKOM. To bi moglo uzrokovati SMRT ili TESKU OZLJEDU djeteta.
HU	SOHA ne használnjon menetiránynak háttal beszerelt gyermekülést AKTIVÁLT (BEKAPCSOLT) FRONTLÉGSZÁKKAL védett ülésen. Ez a gyermek HALÁLÁT vagy SÜLYÖS SÉRÜLÉSÉT okozhatja.
IT	NON installare MAI seggiolini per bambini posizionati in senso contrario a quello di marcia su un sedile protetto da un AIRBAG frontale ATTIVATO. Ciò potrebbe provocare la MORTE o FERITE GRAVI al bambino.
LT	NIEKADA neįrengkite vaiko prilaikymo priemonės su atgal atgręžtu vaiku ant sėdynės, kuri saugoma VEIKIANČIOS priekinės ORO PAGALVĖS. Išsiskleidus oro pagalvei vaikas gali būti MIRTINAI arba SUNKIAI TRAUMUOTAS.

LV	NEKAD NEuzstādiet uz aizmuguri vērstu bērnu sēdekļīti priekšējā pasažiera sēdvietā, kurā ir AKTIVIZĒTS priekšējais DROŠĪBAS GAISA SPILVENS. Tas var izraisīt BĒRNA NĀVI vai radīt NOPIETNUS IEVAINOJUMUS.
MT	Qatt m'ghandek thalli tifel/tifla marbut f'siggu dahrn lejn l-Airbag attiva, ghaliex tista' tikkawza korriment serju jew anke mewt lit-tifel/tifla
NL	Plaats NOOIT een kinderzitje met de rug in de rijrichting op een zitplaats waarvan de AIRBAG is INGESCHAKELD. Bij het afgaan van de airbag kan het KIND LEVENSGEVAARLIJK GEWOND RAKEN
NO	Installer ALDRI et barnesete med ryggen mot kjøretningen i et sete som er beskyttet med en frontal AKTIVERT KOLLISJONSPUTE, BARNET risikerer å bli DREPT eller HARDT SKADET.
PL	NIGDY nie instalować fotelika dziecięcego w pozycji "tyłem do kierunku jazdy" na siedzeniu wyposażonym w CZŁOWIA PODUSZKE POWIETRZNA w stanie AKTYWNYM. Może to doprowadzić do ŚMIERCI DZIECKA lub spowodować u niego POWAŻNE OBRAŻENIA CIAŁA.
PT	NUNCA instale um sistema de retenção para crianças de costas para a estrada num banco protegido por um AIRBAG frontal ACTIVADO. Esta instalação poderá provocar FERIMENTOS GRAVES ou a MORTE da CRIANÇA.
RO	Nu instalati NICIODATA un sistem de retenere pentru copii, dispus cu spatele in directia de mers, pe un loc din vehicul protejat cu AIRBAG frontal ACTIVAT. Aceasta ar putea provoca MOARTEA COPILULUI sau RANIREA lui GRAVA.
RU	ВО ВСЕХ СЛУЧАЯХ ЗАПРЕЩАЕТСЯ использовать обращенное назад детское удерживающее устройство на сиденье, защищенном ФУНКЦИОНИРУЮЩЕЙ ПОДУШКОЙ БЕЗОПАСНОСТИ, установленной перед этим сиденьем. Это может привести к ГИБЕЛИ РЕБЕНКА или НАНЕСЕНИЮ ЕМУ СЕРЬЕЗНЫХ ТЕЛЕСНЫХ ПОВРЕЖДЕНИЙ
SK	NIKDY neinštalujte detské zádržné zariadenie orientované smerom dozadu na sedadlo chránené AKTIVOVANÝM čelným AIRBAGOM. Mohlo by dôjsť k SMRTELNEMU alebo VÁŽNEMU PORANENIU DIETĀTA.
SL	NIKOLI ne nameščajte otroškega sedeža s hrbtom v smeri vožnje, če je VARNOSTNA BLAZINA pred sprednjim sopotnikovim sedežem AKTIVIRANA. Takšna namestitve lahko povzroči SMRT OTROKA ali HUDE POŠKODBE.
SR	NIKADA ne koristite dečje sedišta koje se okreće unazad na sedištu zaštićenim AKTIVNIM VAZDUŠNIM JASTUKOM ispred njega, jer mogu nastupiti SMRT ili OZBILJNA POVREDA DETETA.
SV	Passagerarkrockkudden fram MÅSTE vara avaktiverad om en bakåtvänd bilbarnstol installeras på denna plats. Annars riskerar barnet att DÖDAS eller SKADAS ALLVARLIGT.
TR	KESİNLKLE HAVA YASTIĞI AKTİF olan ön koltuğa yüzü arkaya dönük bir çocuk koltuğu yerleştirmeyiniz. Bu ÇOCUĞUN ÖLMESİNE veya ÇOK AĞIR YARALANMASINA sebep olabilir.



# Child seat at the rear

## Rearward facing

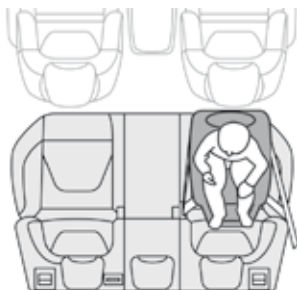

When a rearward facing child seat is installed **on a rear passenger seat**, move the vehicle's front seat forward and straighten the backrest so that the rearward facing child seat does not touch the vehicle's front seat.

## Forward facing

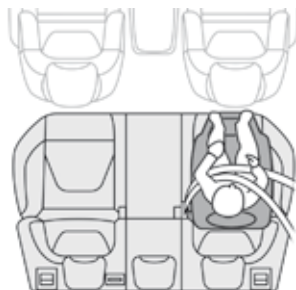

When a forward facing child seat is installed **on a rear passenger seat**, move the vehicle's front seat forward and straighten the backrest so that the legs of the child in the forward facing child seat do not touch the vehicle's front seat.

## Centre rear seat

A child seat with a support leg must never be installed on the **centre rear passenger seat**.



The incorrect installation of a child seat in a vehicle compromises the protection of the child in the event of an accident.



Ensure that the seat belt is correctly tensioned.  
For child seats with a support leg, ensure that this is in firm contact with the floor. If necessary, adjust the front seat of the vehicle.

# Child seats recommended by CITROËN

CITROËN offers a range of recommended child seats which are secured using a **three point seat belt**.

## Group 0+: from birth to 13 kg



**L1**

"RÖMER Baby-Safe Plus"  
Installed in the rearward facing position.

## Groups 2 and 3: from 15 to 36 kg



**L4**

"KLIPPAN Optima"  
From 22 kg (approximately 6 years), the booster is used on its own.





**L5**

"RÖMER KIDFIX"  
Can be fitted to the vehicle's ISOFIX mountings.  
The child is restrained by the seat belt.

# Installing child seats attached using the seat belt

In accordance with European regulations, this table indicates the options for installing child seats secured using a seat belt and universally approved (a) according to the weight of the child and the seating position in the vehicle:

Weight of the child and indicative age					
Seat		Under 13 kg (groups 0 (b) and 0+) Up to approx 1 year	From 9 to 18 kg (group 1) 1 to 3 years approx	From 15 to 25 kg (group 2) 3 to 6 years approx	From 22 to 36 kg (group 3) 6 to 10 years approx
Front passenger seat (c) with height adjustment		U (R)	U (R)	U (R)	U (R)
Outer rear seats (d)		U	U	U	U
Centre rear seat		X	X	X	X

(a) Universal child seat: child seat that can be installed in all vehicles using a seat belt.

(b) Group 0, from birth to 10 kg. Shells seats and baby carriers cannot be installed in the front passenger seat.

When installed in the 2<sup>nd</sup> row, they prevent use of the other seats.

(c) Refer to the legislation in force in your country before installing your child on this seat.

(d) To install a child seat at the rear, rearward facing or forward facing, move the front seat forwards, then straighten the backrest to allow sufficient space for the child seat and the child's legs.

**U:** seat suitable for the installation of a child seat secured using a seat belt and universally approved, rearward facing and/or forward facing.

**U (R):** same as **U**, with the passenger seat adjusted to the highest position and as far back as possible.

**X:** seat position not suitable for installation of a child seat for the weight class indicated.



Remove and stow the head restraint before installing a child seat with a backrest on a passenger seat. Refit the head restraint once the child seat has been removed.

# "ISOFIX" mountings

Your vehicle has been approved in accordance with the **latest ISOFIX regulations**.

The seats, represented below, are fitted with regulation ISOFIX mountings:

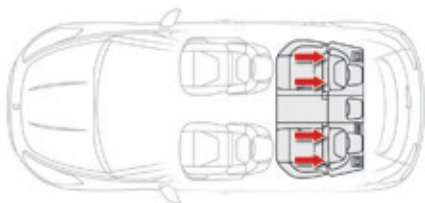

The ISOFIX mountings are three rings for each seat:

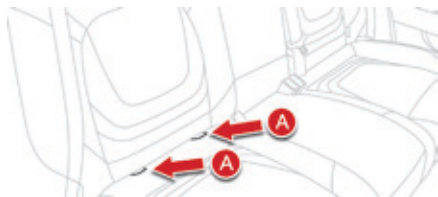

- two rings **A**, located between the vehicle seat back and cushion, indicated by a marking,



- a ring **B**, located under a cover on the back of the top of the seat backrest, referred to as the **TOP TETHER** for fixing the upper strap. Its position is indicated by a marking.

Located on the back of the seat backrest, the top tether is used to secure the upper strap of child seats that have one. This device limits forward tipping of the child seat, in the event of a front impact.

This ISOFIX mounting system ensures fast, reliable and safe fitting of the child seat in your vehicle.

The **ISOFIX child seats** are fitted with two latches which are secured easily on the two rings **A**. Some also have an **upper strap** (or top tether) which is attached to ring **B**.

To secure the child seat to the **TOP TETHER**:

- remove and stow the head restraint before installing the child seat on this seat (refit it after the child seat has been removed),
- open the **TOP TETHER** cover by pulling its cut-out,
- pass the child seat strap behind the seat backrest, centred between the holes for the head restraint rods,
- secure the upper strap fixing to the ring **B**,
- tighten the upper strap.

 The incorrect installation of a child seat in a vehicle compromises the child's protection in the event of an accident. Observe strictly the fitting instructions provided with the child seat.

 For information on the possibilities for fitting ISOFIX child seats to your vehicle, refer to the table of seating positions.



# ISOFIX child seats recommended by CITROËN

CITROËN offers a range of ISOFIX child seats listed and type approved for your vehicle.

## Baby P2C Mini and its ISOFIX base (size categories: C, D, E)

### Group 0+: from birth to 13 kg

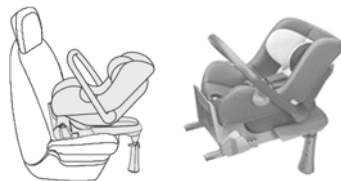

Installed rearward facing using an ISOFIX base which is attached to the anchorage rings **A**.  
The base has a support leg, adjustable for height, which sits on the vehicle's floor.  
This seat can also be secured with a seat belt.  
In this case only the seat shell is used.

 Refer also to the child seat manufacturer's fitting instructions for information on installing and removing the seat.

**"RÖMER Duo Plus ISOFIX"**

(size category **B1**)

**Group 1: from 9 to 18 kg**



Installed only in the forward facing position.

Attached to the rings **A**, as well as the ring **B**, referred to as the TOP TETHER, using an upper strap.

Three seat body angles: sitting, reclining, lying.

This child seat can also be used on seats which are not fitted with ISOFIX mountings. In this case, it must be attached to the vehicle seat using the three point seat belt.

**Baby P2C Midi and its ISOFIX base**

(size categories: **D, C, A, B, B1**)

**Group 1: from 9 to 18 kg**



Installed rearward facing using an ISOFIX base which is attached to the rings **A**.

The base includes a support leg, adjustable for height, which rests on the vehicle's floor.

This child seat can also be used forward facing.



This child seat **can not** be secured with a seat belt.

We recommend that it be used rearward facing up to 3 years.

# Locations for installing ISOFIX child seats

In accordance with European Regulations, this table indicates the options for installing ISOFIX child seats on seats in the vehicle fitted with ISOFIX mountings.

In the case of universal and semi-universal ISOFIX child seats, the ISOFIX size category, determined by a letter from **A** to **G**, is indicated on the child seat next to the ISOFIX logo.

Type of ISOFIX child seat	Weight of the child / indicative age									
	Less than 10 kg (group 0) Up to approx. 6 months		Less than 10 kg (group 0) Less than 13 kg (group 0+) Up to approx. 1 year			From 9 to 18 kg (group 1) From approx. 1 to 3 years				
	Sleeper cot*		rearward facing			rearward facing		forward facing		
ISOFIX size category	F	G	C	D	E	C	D	A	B	B1
Front passenger seat 	X									
Outer rear seats 	IL-SU**		IL-SU			IL-SU		IUF IL-SU		
Centre rear seat 	X									

\* Sleeper cots cannot be fitted to the front passenger's seat.

\*\* The ISOFIX sleeper cot, fixed to the lower ISOFIX rings, occupies all of the rear seats.

**IUF:** seat suitable for the installation of an Isofix **U**niversal seat, **F**orward-facing secured using the upper strap secured to the upper ring on ISOFIX seating positions.

**IL-SU:** seat suitable for the installation of an Isofix **S**emi-**U**niversal seat either:

- rearward facing fitted with an upper strap or a support leg,
- forward facing fitted with a support leg,
- a sleeper cot fitted with an upper strap or a support leg.

For advice on securing of the upper strap, refer to the "Isofix mountings" section.

**X:** seat not suitable for the installation of a child seat or shell for the weight group indicated.



Remove and stow the head restraint before installing a child seat with a backrest on a passenger seat. Refit the head restraint once the child seat has been removed.



## Advice

The incorrect installation of a child seat in a vehicle compromises the child's protection in the event of an accident.

Ensure that there is no seat belt or seat belt buckle under the child seat, as this could destabilise it.

Remember to fasten the seat belts or the child seat harnesses keeping the slack relative to the child's body to a minimum, even for short journeys.

When installing a child seat using the seat belt, ensure that the seat belt is tightened correctly on the child seat and that it secures the child seat firmly on the seat of your vehicle. If your passenger seat is adjustable, move it forwards if necessary.

At rear seating positions, always leave sufficient space between the front seat and:

- a rearward facing child seat,
- the child's feet for a child seat fitted forward facing.

To do this, move the front seat forwards and, if necessary, move its backrest into the upright position.

For optimum installation of the forward facing child seat, ensure that the back of the child seat is as close as possible to the backrest of the vehicle's seat, in contact if possible. You must remove the head restraint before installing a child seat with backrest to a passenger seat.

Ensure that the head restraint is stored or attached securely to prevent it from being thrown around the vehicle in the event of sharp braking. Refit the head restraint when the child seat is removed.

## Children at the front

The legislation on carrying children on the front passenger seat is specific to each country. Refer to the legislation in force in your country.

Deactivate the passenger's front airbag when a rearward facing child seat is installed on the front passenger seat.

Otherwise, the child risks being seriously injured or killed if the airbag is deployed.

## Installing a booster seat

The chest part of the seat belt must be positioned on the child's shoulder without touching the neck.

Ensure that the lap part of the seat belt passes correctly over the child's thighs. CITROËN recommends the use of a booster seat which has a back, fitted with a seat belt guide at shoulder level.

As a safety precaution, do not leave:

- a child or children alone and unsupervised in a vehicle,
- a child or an animal in a vehicle which is exposed to the sun, with the windows closed,
- the keys within reach of children inside the vehicle.

To prevent accidental opening of the doors and rear windows, use the child lock.

Take care not to open the rear windows by more than one third.

To protect young children from the rays of the sun, fit side blinds on the rear windows.

# Electric child lock

Remote control system to prevent opening of the rear doors using their interior controls and use of the rear electric windows.

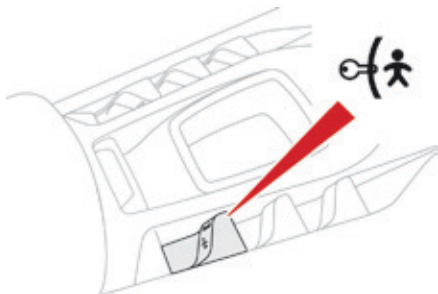

## Switching on



☞ With the ignition on, press this button.

The indicator lamp in the button comes on, accompanied by a message to confirm that the child lock is on. This indicator lamp remains on until the child lock is switched off.



It is still possible to open the doors from the outside and operate the rear electric windows from the driver's control panel.

## Switching off



☞ With the ignition on, press this button again.

The indicator lamp in the button goes off, accompanied by a message to confirm that the child lock is off. This indicator lamp remains off while the child lock is switched off.



Any other status of the indicator lamp indicates a fault with the electric child lock. Have it checked by a CITROËN dealer or a qualified workshop.



This system is independent and in no circumstances does it take the place of the central locking control. Check the state of the child lock each time you switch on the ignition. Always remove the key from the ignition when leaving the vehicle, even for a short time. In the event of a serious impact, the electric child lock is switched off automatically to permit the exit of the rear passengers.



**007**

Safety



## Direction indicators

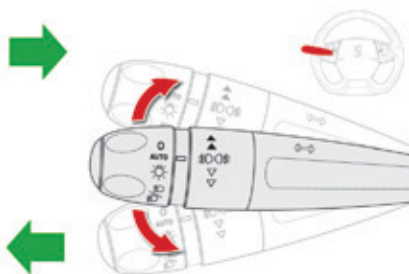

- ☞ Lower the lighting control stalk fully when moving to the left.
- ☞ Raise the lighting control stalk fully when moving to the right.

**i** If you forget to cancel the direction indicators for more than twenty seconds, the volume of the audible signal will increase if the speed is above 40 mph (60 km/h).

On versions fitted with LED direction indicators, the line of LEDs is illuminated sequentially. The brightness of the daytime running lamps is reduced during sequential operation of the direction indicators.

### Three flashes

Move the stalk briefly upwards or downwards, without going beyond the point of resistance; the corresponding direction indicators will flash 3 times.

**i** This function can be used at any speed, but it is particularly useful for changing lane on fast roads.

## Hazard warning lamps

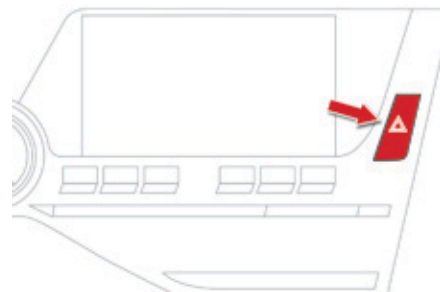

Press the button, the direction indicators flash. They can operate with the ignition off.

### Automatic operation of hazard warning lamps

When braking in an emergency, depending on the rate of deceleration, as well as when the ABS regulation is invoked or in the event of an impact, the hazard warning lamps come on automatically.

They switch off automatically the first time you accelerate.

- ☞ You can also switch them off by pressing the button.

## Emergency or assistance call

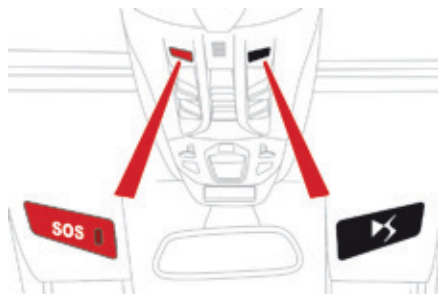



This system allows you to make an emergency or assistance call to the emergency services or to the dedicated service (operated by CITROËN Assistance).

 For more information on the use of this function, refer to the "Audio and telematics" section.

## Horn

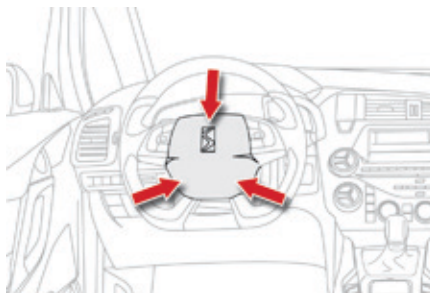
Audible warning system to alert other road users to an imminent danger.



 Press the central part of the multifunction steering wheel.

 Use the horn moderately and only in the circumstances allowed by the traffic regulations in the country in which you are driving.

# Electronic stability control (ESC)

A set of the following Electronic Stability systems:

- anti-lock braking system (ABS) and electronic brake force distribution (EBFD),
- emergency braking assistance,
- wheel anti-slip regulation (ASR) or traction control,
- dynamic stability control (DSC).

## Definitions

### **Anti-lock braking system (ABS) and electronic brake force distribution (EBFD)**

These systems improve the stability and manoeuvrability of your vehicle when braking and contribute towards improved control in corners, in particular on poor or slippery road surfaces.

The ABS prevents wheel lock in the event of emergency braking.

The electronic brake force distribution system manages the braking pressure wheel by wheel.

### **Emergency braking assistance**

In an emergency, this system enables you to reach the optimum braking pressure more quickly and therefore reduce the stopping distance.

It is triggered in relation to the speed at which the brake pedal is pressed. This is felt by a reduction in the resistance of the pedal and an increase in the effectiveness of the braking.

### **Anti-slip regulation (ASR)**

This system (also known as Traction Control) optimises traction in order to avoid wheel slip by acting on the brakes of the driving wheels and on the engine. It also improves the directional stability of the vehicle on acceleration.

### **Dynamic stability control (DSC)**

If there is a difference between the path followed by the vehicle and that required by the driver, this system monitors each wheel and automatically acts on the brake of one or more wheels and on the engine to return the vehicle to the required path, within the limits of the laws of physics.





## Intelligent traction control system ("Snow motion")

Depending on version, your vehicle has a system to help driving on snow: **intelligent traction control**.

This system detects situations of difficult surface adhesion that could make it difficult to move off or make progress on deep fresh snow or compacted snow.

In these situations, the **intelligent traction control** limits the amount of wheel slip to provide the best traction and trajectory control for your vehicle.



The use of snow tyres is strongly recommended on surfaces offering low levels of adhesion.

## Operation

### Anti-lock braking system (ABS) and electronic brake force distribution (EBFD)



When this warning lamp comes on, accompanied by an audible signal and a message, it indicates that there is a fault with the ABS, which could cause loss of control of the vehicle when braking.



When this warning lamp comes on, coupled with the **STOP** warning lamp, accompanied by an audible signal and a message, it indicates that there is a fault with the electronic brake force distribution (EBFD), which could cause loss of control of the vehicle when braking.

**You must stop as soon as it is safe to do so.**

In both cases, contact a CITROËN dealer or a qualified workshop.



When changing wheels (tyres and rims), make sure that these are approved for your vehicle.

Normal operation of the ABS may make itself felt by slight vibrations of the brake pedal.



**In emergency braking, press very firmly without releasing the pressure.**

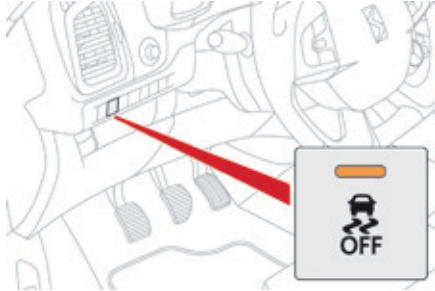

## Dynamic stability control (DSC) and anti-slip regulation (ASR)

### Activation

These systems are activated automatically each time the vehicle is started.

As soon as they detect a problem of grip or trajectory, these systems act on the operation of the engine and brakes.



This is indicated by flashing of this warning lamp in the instrument panel.

### Deactivation

In exceptional conditions (starting a vehicle which is bogged down, stuck in snow, on soft ground...), it may be advisable to deactivate the DSC and ASR, so that the wheels can turn freely and regain grip.

Reactivate the systems as soon as the level of grip permits.



☞ Press this button.

The indicator lamp in the button comes on.

The DSC and ASR systems no longer act on the operation of the engine and on the brakes in the event of an involuntary change of trajectory.

### Reactivation

The systems are reactivated automatically each time the ignition is switched back on or from 30 mph (50 km/h).

Below 30 mph (50 km/h), you can reactivate them manually:



☞ Press this button again.

The indicator lamp in the button goes off.

### Operating fault



Illumination of this warning lamp and the lamp in the deactivation button, accompanied by an audible signal and a message, indicate a fault with the system.

Contact a CITROËN dealer or a qualified workshop to have the system checked.

## DSC/ASR

The DSC and ASR systems offer increased safety in normal driving, but they should not encourage the driver to take extra risks or drive at high speed.

It is in conditions of reduced grip (rain, snow, black ice) that the risk of loss of grip increases. It is therefore important for your safety to keep the DSC and ASR systems activated in all conditions, and particularly in difficult conditions.

The correct operation of these systems depends on observation of the manufacturer's recommendations regarding as much the wheels (tyres and rims), braking and electronic components as the assembly and repair procedures used by CITROËN dealers.

To benefit in full from the effectiveness of the DSC and ASR systems in wintry conditions, the vehicle must be fitted with four snow tyres, allowing the the vehicle to retain neutral handling on the road.

 After an impact, have these systems checked by a CITROËN dealer or a qualified workshop.

# Seat belts

## Front seat belts



The front seat belts are fitted with a pretensioning and force limiting system. This system improves safety in the front seats in the event of a front or side impact. Depending on the severity of the impact, the pretensioning system instantly tightens the seat belts against the body of the occupants. The pretensioning seat belts are active when the ignition is on. The force limiter reduces the pressure of the seat belt on the chest of the occupant, so improving their protection.

## Rear seat belts

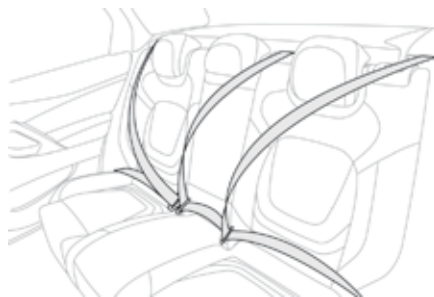

The rear seats are each fitted with a seat belt, three-point anchorages with inertia reel and force limiter (except for the centre rear seat).



## Fastening

- ☞ Pull the strap, then insert the tongue in the buckle.
- ☞ Check that the seat belt is fastened correctly by pulling the strap.

## Unfastening

- ☞ Press the red button on the buckle.
- ☞ Guide the seat belt as it reels in.

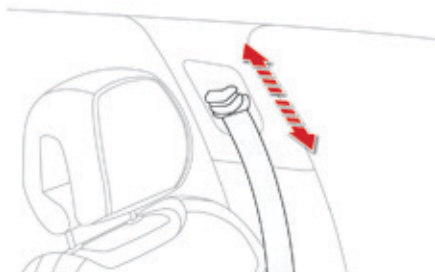

### Front seat belt height adjustment

- To adjust the anchorage point, squeeze the control and slide it until you find a notch.

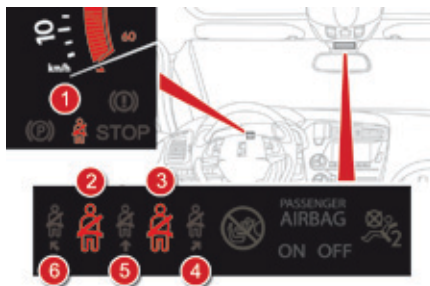

### Seat belt not fastened / unfastened warning lamps\*

- Front and/or rear seat belts not fastened / unfastened warning lamp in the instrument panel.
- Front left seat belt warning lamp.
- Front right seat belt warning lamp.
- Rear right seat belt warning lamp.
- Rear centre seat belt warning lamp.
- Rear left seat belt warning lamp.



From approximately 12 mph (20 km/h), the warning lamp(s) flash for two minutes accompanied by an audible signal. Once these two minutes have elapsed, the warning lamp(s) remain on until the driver or one or more passengers fasten their seat belt.

### Front seat belt warning lamps



On switching on the ignition, warning lamp 1 comes on in the instrument panel and the corresponding warning lamp 2 and/or 3 come(s) on in red in the passenger's seat belt and front airbag warning lamp display, if the corresponding seat belt is not fastened or is unfastened.

### Rear seat belt warning lamps



On switching on the ignition, the corresponding warning lamps 4, 5 and 6 come on in red for about 30 seconds if a seat belt is not fastened. Above 12 mph (20 km/h), the corresponding warning lamps 4, 5 or 6 comes on in red, accompanied by an audible signal and a message in the instrument panel screen, when a rear passenger has unbuckled their seat belt.

\* Depending on version and/or country of sale.

## Advice

The driver must ensure that passengers use the seat belts correctly and that they are all fastened before setting off.

Wherever you are seated in the vehicle, always fasten your seat belt, even for short journeys.

Do not interchange the seat belt buckles as they will not fulfil their role fully.

The seat belts are fitted with an inertia reel permitting automatic adjustment of the length of the strap to your size. The seat belt is stowed automatically when not in use.

Before and after use, ensure that the seat belt is reeled in correctly.

The lower part of the strap must be positioned as low as possible on the pelvis. The upper part must be positioned in the hollow of the shoulder.

The inertia reels are fitted with an automatic locking device which comes into operation in the event of a collision, emergency braking or if the vehicle rolls over. You can release the device by pulling the strap firmly and then releasing it so that it reels in slightly.

In order to be effective, a seat belt must:

- be tightened as close to the body as possible,
- be pulled in front of you with a smooth movement, checking that it does not twist,
- be used to restrain only one person,
- not bear any trace of cuts or fraying,
- not be converted or modified to avoid affecting its performance.

In accordance with current safety regulations, for all repairs on your vehicle's seat belts, go to a qualified workshop with the skills and equipment needed, which a CITROËN dealer is able to provide.

Have your seat belts checked regularly by a CITROËN dealer or a qualified workshop, particularly if the straps show signs of damage.

Clean the seat belt straps with soapy water or a textile cleaning product, sold by CITROËN dealers.

After folding or moving a seat or rear bench seat, ensure that the seat belt is positioned and reeled in correctly.

## Recommendations for children

Use a suitable child seat if the passenger is less than 12 years old or shorter than one and a half metres.

Never use the same seat belt to secure more than one person.

Never allow a child to travel on your lap.

For more information on child seats, refer to the corresponding section.

## In the event of an impact

**Depending on the nature and seriousness of the impact**, the pretensioning device may be deployed before and independently of the airbags. Deployment of the pretensioners is accompanied by a slight discharge of harmless smoke and a noise, due to the activation of the pyrotechnic cartridge incorporated in the system.

In all cases, the airbag warning lamp comes on.

Following an impact, have the seat belts system checked, and if necessary replaced, by a CITROËN dealer or a qualified workshop.

# Airbags

## General information

System designed to contribute towards improving the safety of the occupants (with the exception of the rear centre passenger) in the event of violent collisions. The airbags supplement the action of the seat belts fitted with force limiters (all except the centre rear passenger belt).

If a collision occurs, the electronic detectors record and analyse the front and side impacts sustained in the impact detection zones:

- in the case of a serious impact, the airbags are deployed instantly and contribute towards better protection of the occupants of the vehicle (with the exception of the rear centre passenger); immediately after the impact, the airbags deflate rapidly so that they do not hinder visibility or the exit of the occupants,
- in the case of a minor or rear impact or in certain roll-over conditions, the airbags may not be deployed; the seat belt alone contributes towards ensuring your protection in these situations.

### The airbags do not operate when the ignition is switched off.

This equipment will only deploy once. If a second impact occurs (during the same or a subsequent accident), the airbag will not be deployed again.

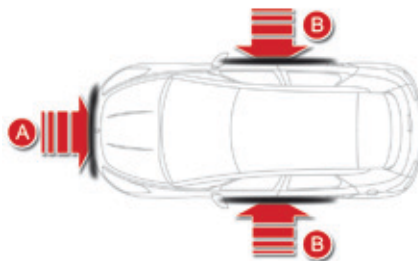

## Impact detection zones

- A. Front impact zone.
- B. Side impact zone.



Deployment of one or more of the airbags is accompanied by a slight emission of smoke and a noise, due to the activation of the pyrotechnic cartridge incorporated in the system. This smoke is not harmful, but sensitive individuals may experience slight irritation.

The noise of detonation related to the deployment of one or more airbags may result in a slight loss of hearing for a short time.

## Front airbags

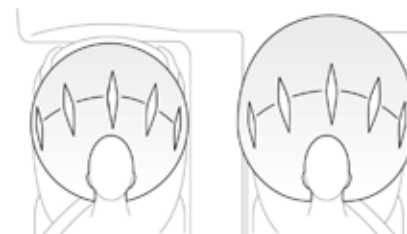

System which protects the driver and front passenger in the event of a serious front impact in order to limit the risk of injury to the head and thorax.

The driver's airbag is fitted in the centre of the steering wheel; the front passenger's airbag is fitted in the dashboard above the glove box.

## Deployment

The airbags are deployed, except the passenger's front airbag if it is deactivated, in the event of a serious front impact to all or part of the front impact zone A, in the longitudinal centreline of the vehicle on a horizontal plane and directed from the front to the rear of the vehicle.

The front airbag inflates between the thorax and head of the front occupant of the vehicle and the steering wheel, driver's side, and the dashboard, passenger's side to cushion their forward movement.

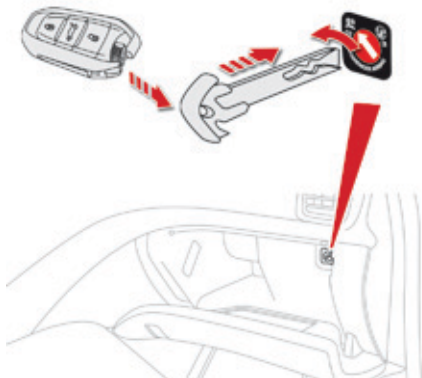

## Deactivation

Only the passenger's front airbag can be deactivated:

- ☞ insert the key in the passenger airbag deactivation switch,
- ☞ turn it to the "OFF" position,
- ☞ then, remove the key keeping the switch in the new position.



According to version, this warning lamp comes on either in the instrument panel or in the seat belt and passenger's front airbag warning lamp display when the ignition is on and until the airbag is reactivated.



To assure the safety of your child, the passenger's front airbag must be deactivated when you install a rearward facing child seat on the front passenger seat.

Otherwise, the child would risk being seriously injured or killed if the airbag were deployed.

## Reactivation

When you remove the child seat, **with the ignition off**, turn the switch to the "ON" position to reactivate the airbag and so assure the safety of your front passenger in the event of an impact.



With the ignition on, this warning lamp comes on in the seat belt and passenger's front airbag warning lamp display for approximately one minute, if the passenger's front airbag is activated.

## Operating fault



If this warning lamp comes on in the instrument panel, accompanied by an audible warning and a message in the instrument panel screen, contact a CITROËN dealer or a qualified workshop to have the system checked. The airbags may no longer be deployed in the event of a serious impact.



## Lateral airbags

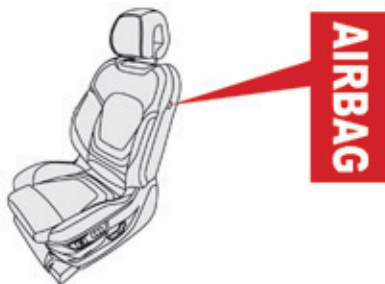

System which protects the driver and front passenger in the event of a serious side impact in order to limit the risk of injury to the chest, between the hip and the shoulder. Each lateral airbag is fitted in the seat backrest frame, door side.

### Deployment

A lateral airbag is deployed unilaterally in the event of a serious side impact applied to all or part of the side impact zone **B**, perpendicular to the longitudinal centreline of the vehicle on a horizontal plane and directed from the outside towards the inside of the vehicle. The lateral airbag inflates between the hip and shoulder of the front occupant of the vehicle and the corresponding door trim panel.

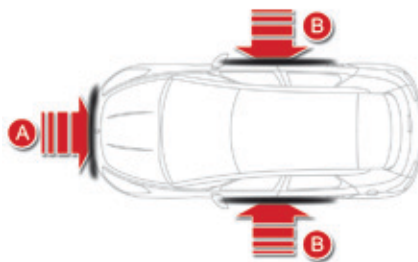

### Impact detection zones

- A. Front impact zone.
- B. Side impact zone.

## Curtain airbags

System which protects the driver and passengers (with the exception of the rear centre passenger) in the event of a serious side impact in order to limit the risk of injury to the side of the head. Each curtain airbag is built into the pillars and the upper passenger compartment area.

### Deployment

The curtain airbag is deployed at the same time as the corresponding lateral airbag in the event of a serious side impact applied to all or part of the side impact zone **B**, perpendicular to the longitudinal centreline of the vehicle on a horizontal plane and directed from the outside towards the inside of the vehicle.

The curtain airbag inflates between the front or rear occupant of the vehicle and the windows.

### Operating fault



If this warning lamp comes on in the instrument panel, accompanied by an audible signal and a message in the instrument panel screen, contact a CITROËN dealer or a qualified workshop to have the system checked. The airbags may no longer be deployed in the event of a serious impact.



In the event of a minor impact or bump on the side of the vehicle or if the vehicle rolls over, the airbag may not be deployed. In the event of a rear or front collision, the lateral and curtain airbags are not deployed.

## Advice

**For the airbags to be fully effective, observe the safety recommendations below:**

Sit in a normal upright position.  
Wear a correctly adjusted seat belt.  
Do not leave anything between the occupants and the airbags (a child, pet, object...), nor fix or attach anything close to the inflation trajectory of the airbags; this could cause injuries during their deployment.  
Never modify the original definition of your vehicle, particularly in the area directly around the airbags.  
After an accident or if the vehicle has been stolen or broken into, have the airbag systems checked.  
All work on the airbag system must be carried out by a CITROËN dealer or a qualified workshop.  
Even if all of the precautions mentioned are observed, a risk of injury or of minor burns to the head, chest or arms when an airbag is deployed cannot be ruled out. The bag inflates almost instantly (within a few milliseconds) then deflates within the same time discharging the hot gas via openings provided for this purpose.

### Front airbags

Do not drive holding the steering wheel by its spokes or resting your hands on the centre part of the wheel.  
Passengers must not place their feet on the dashboard.  
Do not smoke as deployment of the airbags can cause burns or the risk of injury from a cigarette or pipe.  
Never remove or pierce the steering wheel or hit it violently.  
Do not fit or attach anything to the steering wheel or dashboard, this could cause injuries with deployment of the airbags.

### Lateral airbags

Use only approved covers on the seats, compatible with the deployment the lateral airbags. For information on the range of seat covers suitable for your vehicle, you can contact a CITROËN dealer.  
For more information on accessories, refer to the corresponding section.  
Do not fix or attach anything to the seat backs (clothing...). This could cause injury to the chest or arms if the lateral airbag is deployed.  
Do not sit with the upper part of the body any nearer to the door than necessary.

### Curtain airbags

Do not fix or attach anything to the roof. This could cause injury to the head if the curtain airbag is deployed.  
If fitted on your vehicle, do not remove the grab handles installed on the roof, they play a part in securing the curtain airbags.



**008**

Practical information



# Temporary puncture repair kit

This kit consists of a compressor and a sealant cartridge.

It allows the **temporary repair** of a tyre.

You are then able to go to the nearest garage.

It is designed to repair most punctures which could affect the tyre, located on the tyre tread or shoulder.

Its compressor can be used to check and adjust the pressure of the tyre.

## Access to the kit

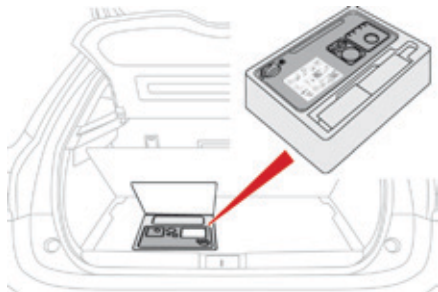

This kit is installed in the storage box, under the boot floor.

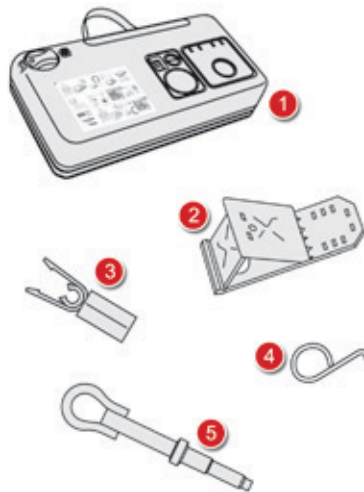

## List of tools\*

All of these tools are specific to your vehicle and can vary according to equipment.

Do not use them for other purposes.

1. 12 V compressor.  
Contains a sealant cartridge for the temporary repair of a tyre and can also be used for adjusting tyre pressures.
2. Chock.  
For blocking the wheels of the vehicle.
3. Wheel bolt cap removal tool.  
For removing the wheel bolt head protectors on alloy wheels.
4. Wheel finisher remover.  
For removing the wheel finishers on alloy wheels.
5. Removable towing eye.

For more information on towing the vehicle, refer to the corresponding section.

\* Depending on country of sale.



## Description of the kit

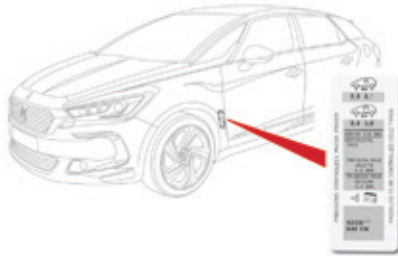

The tyre inflation pressures are given on this label.

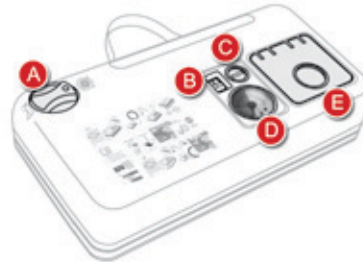

- A. "Sealant" or "Air" position selector.
- B. On "I" / off "O" switch.
- C. Deflation button.
- D. Pressure gauge (in bar and psi).
- E. Compartment housing:
  - a cable with adaptor for 12 V socket,
  - various inflation adaptors for accessories, such as balls, bicycle tyres...

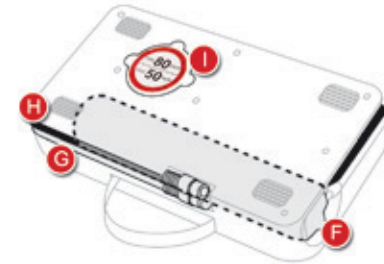

- F. Sealant cartridge.
- G. White pipe with cap for repair.
- H. Black pipe for inflation.
- I. Speed limit sticker.

**i** The speed limit sticker I must be affixed to the vehicle's steering wheel to remind you that a wheel is in temporary use. Do not exceed a speed of 50 mph (80 km/h) when driving with a tyre repaired using this type of kit.

## Repair procedure

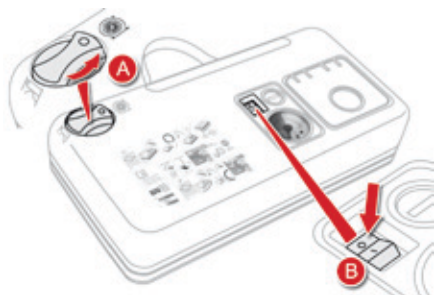

### 1. Sealing

- ☞ Switch off the ignition.
- ☞ Turn the selector **A** to the "sealant" position.
- ☞ Check that the switch **B** is in position "O".



**i** Avoid removing any foreign bodies which have penetrated into the tyre.

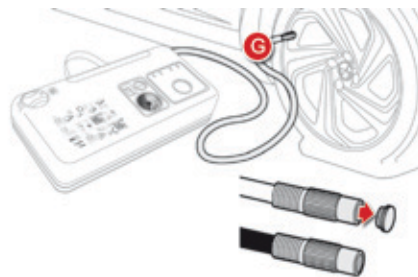

- ☞ Uncoil the white pipe **G** fully.
- ☞ Unscrew the cap from the white pipe.
- ☞ Connect the white pipe to the valve of the tyre to be repaired.

**!** Take care, this product is harmful (e.g. ethylene-glycol, colophony...) if swallowed and causes irritation to the eyes. Keep this product out of the reach of children.



- ☞ Connect the compressor's electric plug to the vehicle's 12 V socket.
- ☞ Start the vehicle and leave the engine running.

**i** The vehicle's electric system allows the connection of a compressor for long enough to inflate a tyre after a puncture repair or for inflating a small inflatable accessory.



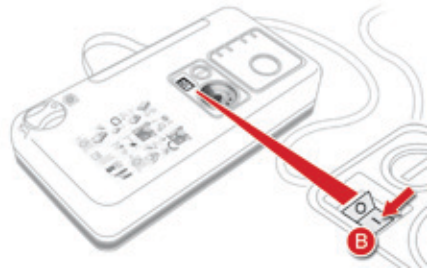



- ☞ Switch on the compressor by moving the switch **B** to position "I" until the tyre pressure reaches 2.0 bars. The sealant is injected into the tyre under pressure; do not disconnect the pipe from the valve during this operation (risk of splashing).

### Tyre under-inflation detection

If the vehicle is fitted with tyre under-inflation detection, the under-inflation warning lamp will remain on after the wheel has been repaired until the system is reinitialised by a CITROËN dealer or a qualified workshop.

-  Do not start the compressor before connecting the white pipe to the tyre valve: the sealant product would be expelled through the pipe.

-  If after around 5 to 7 minutes the pressure is not attained, this indicates that the tyre is not repairable; contact a CITROËN dealer or a qualified workshop for assistance.

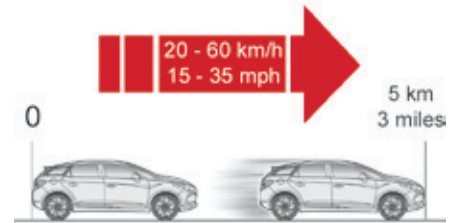

- ☞ Remove the kit and screw the cap back on the white pipe. Take care to avoid staining your vehicle with traces of fluid. Keep the kit to hand.
- ☞ Drive immediately for approximately three miles (five kilometres), at reduced speed (between 15 and 35 mph (20 and 60 km/h)), to plug the puncture.
- ☞ Stop to check the repair and the tyre pressure using the kit.

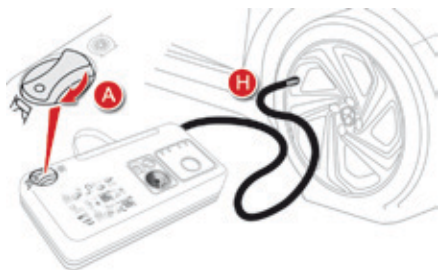

## 2. Inflation

- ☞ Turn the selector **A** to the "air" position.
- ☞ Uncoil the black pipe **H** fully.
- ☞ Connect the black pipe to the valve of the wheel.

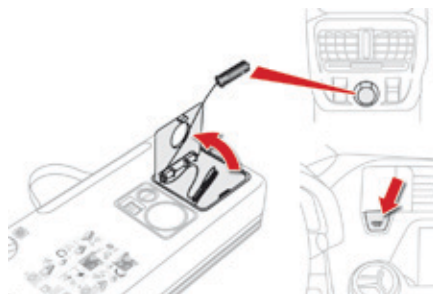

- ☞ Connect the compressor's electric plug to the vehicle's 12 V socket.
- ☞ Start the vehicle again and leave the engine running.

**H** As soon as possible, go to a CITROËN dealer or a qualified workshop. You must inform the technician that you have used this kit. After inspection, the technician will advise you on whether the tyre can be repaired or if it must be replaced.

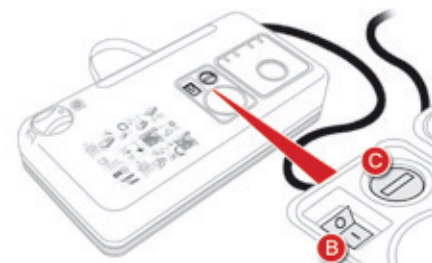

- ☞ Adjust the pressure using the compressor (to inflate: switch **B** in position "I"; to deflate: switch **B** in position "O" and press button **C**), in accordance with the vehicle's tyre pressure label (located on the left hand door aperture).
- A loss of pressure indicates that the puncture has not been fully plugged; contact a CITROËN dealer or qualified workshop for assistance.
- ☞ Remove and stow the kit.
- ☞ Drive at reduced speed (50 mph [80 km/h] max) limiting the distance travelled to approximately 120 miles (200 km).

## Removing the cartridge

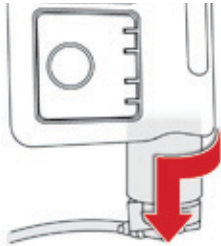

- ☞ Stow the black pipe.
- ☞ Detach the angled base from the white pipe.
- ☞ Support the compressor vertically.
- ☞ Unscrew the cartridge from the bottom.

**⚠ Beware of discharges of fluid.**  
The expiry date of the fluid is indicated on the cartridge.  
The sealant cartridge is designed for single use; even if only partly used, it must be replaced.  
After use, do not discard the cartridge into the environment, take it to an authorised waste disposal site or a CITROËN dealer.  
Do not forget to obtain a new sealant cartridge, available from CITROËN dealers or from a qualified workshop.

## Checking tyre pressures / inflating accessories

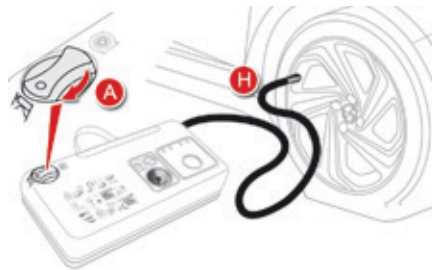

You can also use the compressor, without injecting any product, to:

- check or adjust the pressure of your tyres,
  - inflate other accessories (balls, bicycle tyres...).
- ☞ Turn the selector **A** to the "Air" position.
  - ☞ Uncoil the black pipe **H** fully.
  - ☞ Connect the black pipe to the valve of the wheel or accessory.  
If necessary, fit one of the adaptors supplied with the kit first.



- ☞ Connect the compressor's electrical connector to the vehicle's 12 V socket.
- ☞ Start the vehicle and let the engine run.
- ☞ Adjust the pressure using the compressor (to inflate: switch **B** in position "I"; to deflate: switch **B** in position "O" and press button **C**), according to the vehicle's tyre pressure label or the accessory's pressure label.
- ☞ Remove the kit then stow it.

# Changing a wheel

Procedure for changing a wheel with a damaged or punctured tyre for the spare wheel using the tools provided with the vehicle.

## Access to the tools

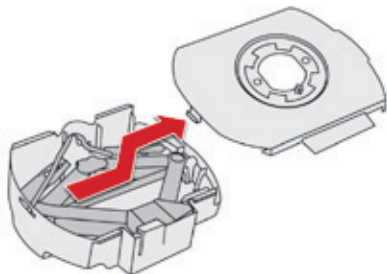

The jack is stowed in a box attached to the spare wheel.  
The assembly is secured under the vehicle by means of a winch system.  
Refer to the "Access to the spare wheel" section.

To open the tool box:

- ☞ press the tab, slide the lid on the box half way, then remove it.

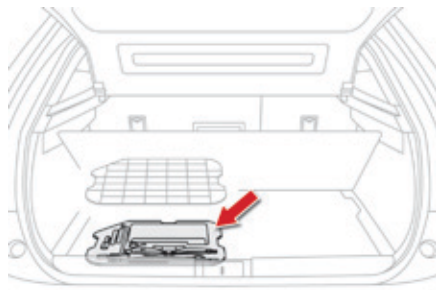

The other tools are stowed in a well under the boot floor.

- i** The jack must only be used to change a wheel with a damaged or punctured tyre.  
Do not use any jack other than the one supplied with this vehicle.  
If the vehicle does not have its original jack, contact a CITROËN dealer or a qualified workshop to obtain the correct jack for it.  
The jack does not require any maintenance.

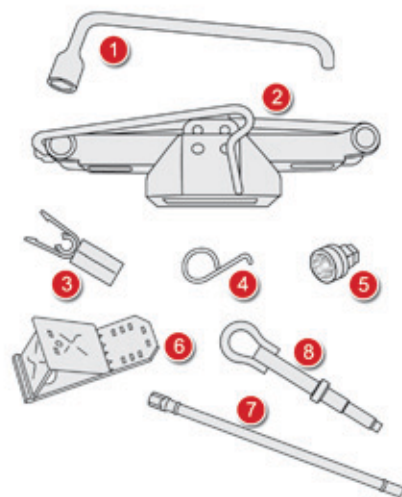

**H** All of these tools are specific to your vehicle and can vary according to equipment. Do not use them for any other purposes.

### List of tools\*

1. Wheelbrace.  
For removing the wheel trim and removing the wheel bolts.
2. Jack with integral handle.  
For raising the vehicle.
3. Wheel bolt cover removal tool.  
For removing the bolt head protectors on alloy wheels.
4. Wheel trim remover.  
For removing the alloy wheel finishers.
5. Socket for the security bolts (located in the glove box).  
For adapting the wheelbrace to the special "security" bolts.
6. Chock.  
For blocking the vehicle's wheels.
7. Wheelbrace extension.  
For slackening/tightening the spare wheel carrier nut.
8. Removable towing eye.

For more information on towing the vehicle, refer to the corresponding section.

## Access to the spare wheel

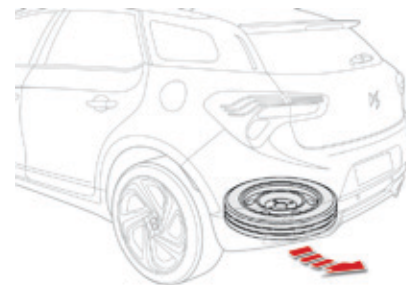

The spare wheel is supported by a winch carrier system underneath the vehicle.

### **i** Tyre under-inflation detection

The spare wheel is not fitted with a sensor. The punctured wheel must be repaired by a CITROËN dealer or a qualified workshop.

\* Depending on country of sale.

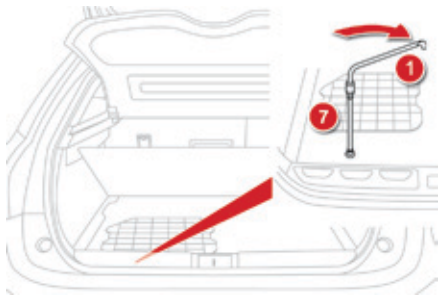

## Taking out the spare wheel

- ☞ Raise the floor to reveal the spare wheel carrier drive nut.
- ☞ Turn this drive nut fully clockwise, using the wheelbrace **1** and the extension **7**, to unwind the winch cable, until the spare wheel is flat on the ground. Unwind the link needed for access to the wheel.

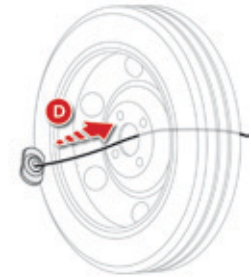
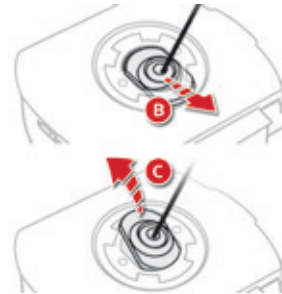
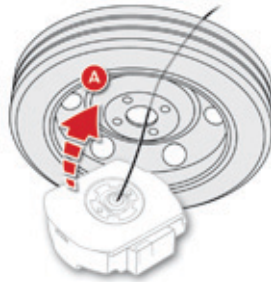

- ☞ Detach the assembly of wheel and box from the rear of the vehicle.
- ☞ Straighten the spare wheel for access to the spare wheel.
- ☞ Detach the link piece from the tool box lid.
- ☞ Pass the link piece through the middle of the wheel to free it.

**!** When the spare wheel is fitted in place of a punctured wheel, you must refit the winch carrier and tool box under the vehicle before setting off. Refer to the "Putting the winch carrier and spare wheel back in place" section.

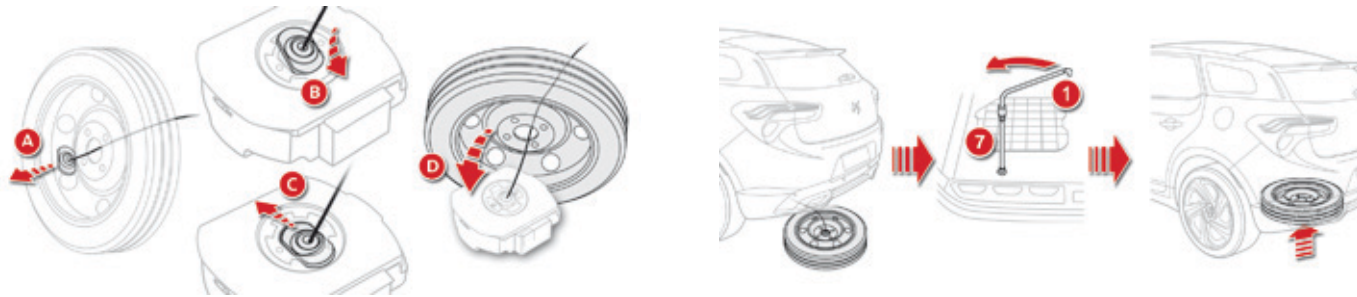

## Putting the winch carrier and spare wheel back in place

This procedure is to be carried out whether the spare wheel is present or not. Without the spare wheel, skip steps **A** and **D**.

Only a "space-saver" type spare wheel can be secured under the vehicle using the winch carrier.

- ☞ Stow the jack in the box and refit the lid.
- ☞ Place the closed box flat on the ground, close to the rear of the vehicle.
- ☞ Straighten the spare wheel and pass the link piece through the middle of the wheel.
- ☞ Insert the link piece in the tool box aperture.

- ☞ Centre the spare wheel on the tool box.
- ☞ Place the assembly of wheel and tool box under the rear of the vehicle.
- ☞ Raise the assembly of wheel and tool box under the vehicle by turning the winch drive nut anticlockwise using the wheelbrace **1** and the extension **7**.

- ☞ Tighten fully and check that the wheel is horizontally flush against the floor.

## Removing a wheel



### **i** Parking the vehicle

Immobilise the vehicle where it does not block traffic: the ground must be level, stable and not slippery.

Apply the parking brake unless it has been programmed to automatic mode, switch off the ignition and engage first gear\* to block the wheels.

Check that the braking warning lamp and the **P** warning lamp in the parking brake control lever come on.

If necessary, place a chock against the wheel opposite the wheel to be changed.

The occupants must get out of the vehicle and wait where they are safe.

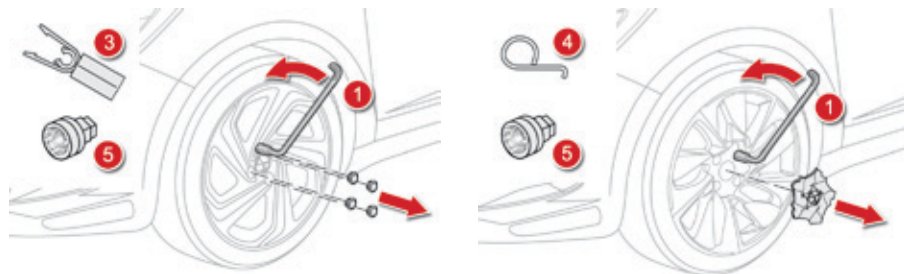

### List of operations

- ☞ Depending on equipment, remove the protective cover from from each of bolts using the tool 3 or remove the wheel trim using tool 4.
- ☞ Fit the security socket 5 on the wheelbrace 1 to slacken the security bolt (if fitted).
- ☞ Slacken the other bolts (no more than a 1/4 turn) using the wheelbrace 1 only.

**H** Never go underneath a vehicle raised using a jack; use an axle stand.

\* Position **P** for an automatic gearbox.



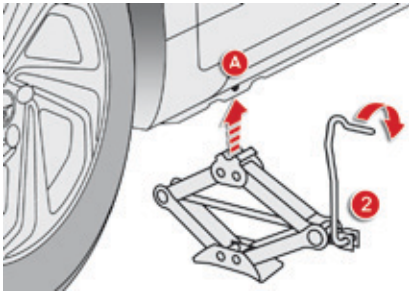

- ☞ Position the foot of the jack **2** on the ground and ensure that it is directly below the front **A** or rear **B** jacking point provided on the underbody, whichever is closest to the wheel to be changed.

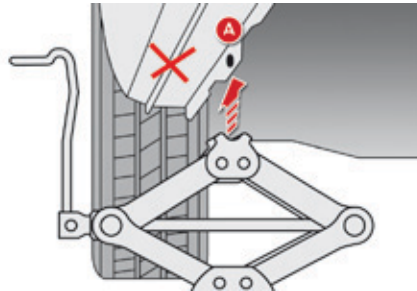

- ☞ Extend the jack **2** until it comes into contact with the jacking point **A** or **B** used; the contact surface at the jacking point **A** or **B** must be correctly engaged with the central part of the head of the jack

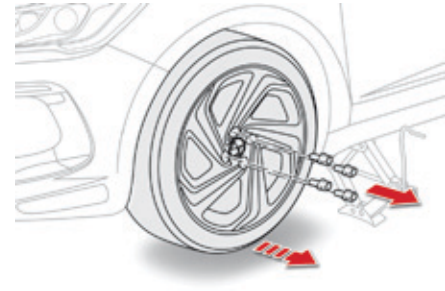

- ☞ Raise the vehicle until there is sufficient space between the wheel and the ground to admit the spare (not punctured) wheel easily.
- ☞ Remove the bolts and store them in a clean place.
- ☞ Remove the wheel.

**!** Ensure that the jack is stable. If the ground is slippery or loose, the jack may slip or drop - Risk of injury!

Ensure that the jack is positioned only at one of the jacking points **A** or **B** under the vehicle, making sure that the vehicle's contact surface is centred on the head of the jack. Otherwise there is a risk of damage to the vehicle and/or of the jack dropping - Risk of injury!

## Fitting a wheel



### Fitting the "space-saver" spare wheel

If your vehicle is fitted with alloy wheels, when tightening the bolts on fitting, it is normal to notice that the washers do not come into contact with the "space-saver" spare wheel. The wheel is secured by the conical surface of each bolt.

### After changing a wheel

The wheel with the punctured tyre cannot be fitted under the vehicle. It must be stowed flat on the boot floor; use a cover to protect the inside of the boot.



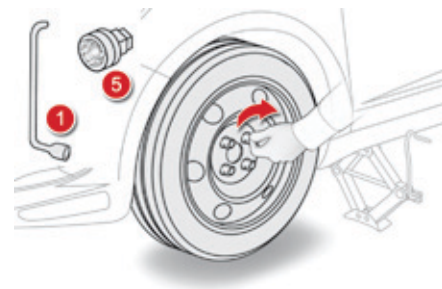

Do not exceed 50 mph (80 km/h) when driving with the "space-saver" type spare wheel fitted.

Have the tightening of the bolts and the pressure of the spare wheel checked by a CITROËN dealer or a qualified workshop without delay.

Have the punctured wheel repaired and refitted to the vehicle as soon as possible.



### List of operations

-  Put the wheel in place on the hub.
-  Screw in the bolts fully by hand.
-  Pre-tighten the security bolt using the wheelbrace 1 fitted with the security socket 5.
-  Pre-tighten the other bolts using the wheelbrace 1 only.

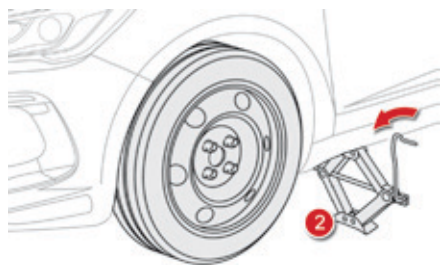

- ☞ Lower the vehicle fully.
- ☞ Fold the jack 2 and detach it.

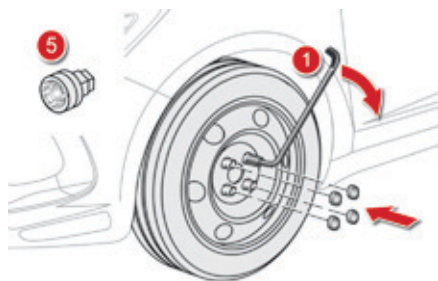

- ☞ Tighten the security bolt using the wheelbrace 1 fitted with the security socket 5.
- ☞ Tighten the other bolts using the wheelbrace 1 only.
- ☞ Refit the bolt protectors on each of the bolts or the wheel trim (depending on equipment).
- ☞ Store the tools in the box.

# Snow chains

In wintry conditions, snow chains improve traction as well as the behaviour of the vehicle when braking.

 The snow chains must be fitted only to the front wheels. They must never be fitted to "space-saver" type spare wheels.





Use only the chains designed to be fitted to the type of wheel fitted to your vehicle:

Original tyre size	Maximum link size.
215/60 R16	9 mm
225/50 R17	
235/45 R18	cannot be fitted with snow chains
235/40 R19	

For more information on snow chains, contact a CITROËN dealer or a qualified workshop.

 Take account of the legislation in force in your country on the use of snow chains and the maximum running speed authorised.

## Advice on installation

-  If you have to fit the chains during a journey, stop the vehicle on a flat surface on the side of the road.
-  Apply the parking brake and position any wheel chocks to prevent movement of your vehicle.
-  Fit the chains following the instructions provided by the manufacturer.
-  Move off gently and drive for a few moments, without exceeding 30 mph (50 km/h).
-  Stop your vehicle and check that the snow chains are correctly tightened.

 It is strongly recommended that before you leave, you practise fitting the snow chains on a level and dry surface.

 Avoid driving with snow chains on roads that have been cleared of snow, to avoid damaging your vehicle's tyres and the road surface. If your vehicle is fitted with alloy wheels, check that no part of the chain or its fixings is in contact with the wheel rim.

# Changing a bulb

## Front lamps

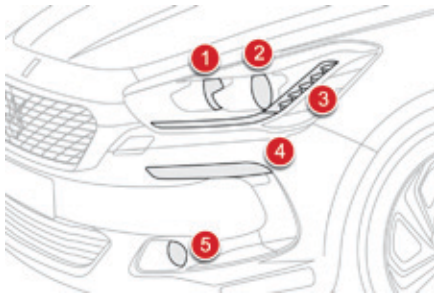

### Model with halogen headlamps

1. Main beam headlamps (H1).
2. Dipped beam headlamps (H7).
3. Daytime running lamps / sidelamps (LEDs)\*.
4. Direction indicators (HY21).
5. Directional foglamps (H11).

**i** For bulbs with lugs (type H7...) take care to observe their correct installation so as to ensure the best lighting performance.

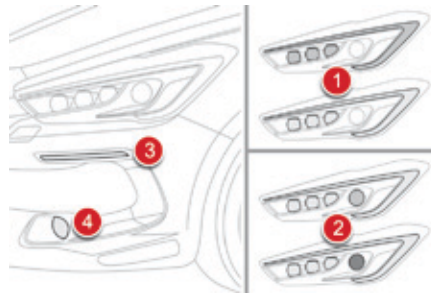

### Model with directional xenon headlamps

1. Daytime running lamps / sidelamps (LEDs).
2. Directional main beam / dipped beam headlamps (D1S).
3. Direction indicators (LEDs).
4. Directional foglamps (LEDs).

### Light-emitting diodes (LED)

For the replacement of this type of lamp, go to a CITROËN dealer or a qualified workshop. LED (light-emitting diode) replacement kits are available from CITROËN dealers.

#### **⚠ Risk of electrocution**

Xenon bulbs (D1S) must be replaced by a CITROËN dealer or a qualified workshop.

**i** In some weather conditions (e.g. low temperature or humidity), the presence of misting on the internal surface of the glass of the headlamps and rear lamps is normal; it disappears after the lamps have been on for a few minutes.

\* LEDs: light-emitting diodes.



The headlamps are fitted with polycarbonate glass with a protective coating:

- ☞ **do not clean them using a dry or abrasive cloth, nor with a detergent or solvent product,**
- ☞ use a sponge and soapy water or a pH neutral product,
- ☞ when using a high pressure washer on persistent marks, do not keep the lance directed towards the lamps or their edges for too long, so as not to damage their protective coating and seals.



Changing a bulb should only be done after the headlamp has been switched off for several minutes (risk of serious burns).

- ☞ Do not touch the bulb directly with your fingers, use a lint-free cloth. It is imperative to use only anti-ultraviolet (UV) type bulbs to avoid damaging the headlamp. Always replace a failed bulb with a new bulb with the same type and specification.

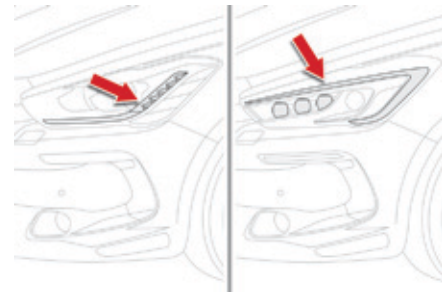

### Daytime running lamps / sidelamps

For the replacement of this type of LED lamp and lighting guides, contact a CITROËN dealer or a qualified workshop.

A replacement kit for the LEDs is available from CITROËN dealers.

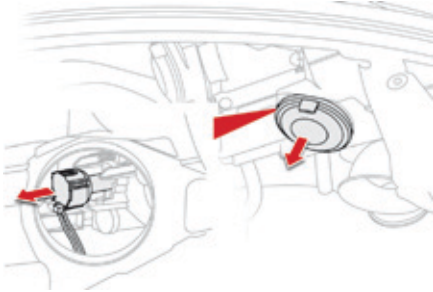

### Main beam headlamps (halogen model)

- ☞ Remove the protective plastic cover by pulling on the tab.
- ☞ Remove the connector with the bulb by pressing on the lug at the bottom.
- ☞ Remove the bulb and change it.

For reassembly, carry out these operations in reverse order.

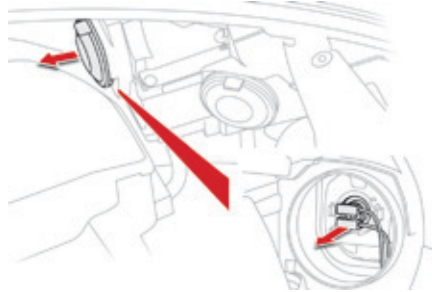

### Dipped beam headlamps (halogen model)

- ☞ Remove the protective plastic cover by pulling on the tab.

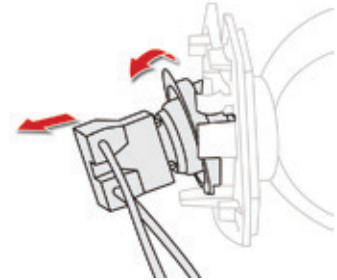

- ☞ Press on the top of the connector then pivot the assembly downwards.
- ☞ Remove the connector with the bulb.
- ☞ Remove the bulb and change it.

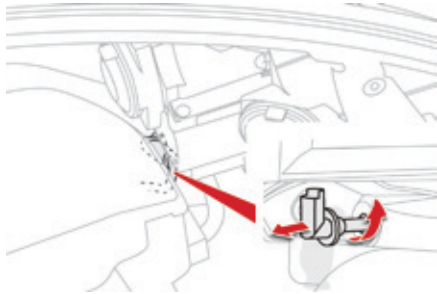

For reassembly, carry out these operations in reverse order, but engaging the bottom of the bulb first.



## Direction indicators



-  Faster flashing of a direction indicator warning lamp (left or right) indicates a failed bulb on that side.

The direction indicator bulb is located below the front lamp.

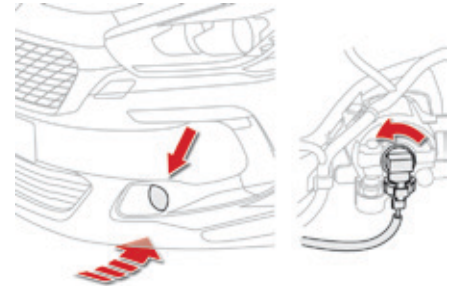
-  Turn the bulb holder a quarter turn and pull it out.
-  Remove the bulb and change it.



## Front foglamps

-  Remove the deflector under the body.
-  Disconnect the bulb connector.
-  Turn the bulb a quarter of a turn, withdraw and change it.

To refit, carry out these operations in reverse order.

To replace these bulbs you may also contact a CITROËN dealer or a qualified workshop.





## Integrated direction indicator side repeaters

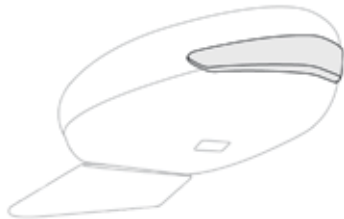

You should contact a CITROËN dealer or a qualified workshop for the replacement of these bulbs.

## Door mirror spotlamps

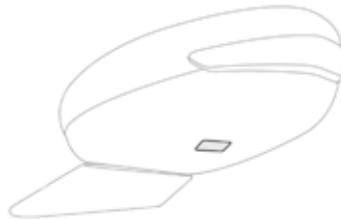

You should contact a CITROËN dealer or a qualified workshop for the replacement of the light emitting diode - LED.

## Rear lamps

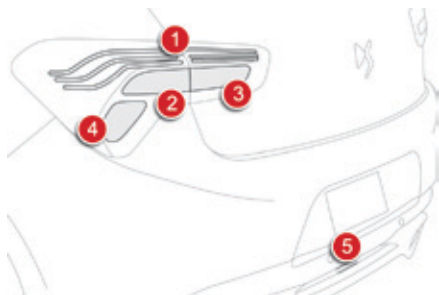

1. **Sidelamps**  
(light emitting diodes - LEDs).
2. **Direction indicators** (PY21W amber).
3. **Reversing lamps** (P21W).
4. **Brake lamps** (P21W).
5. **Foglamps** (P21W).

### Light emitting diodes-LEDs

For replacement, contact a CITROËN dealer or qualified workshop.

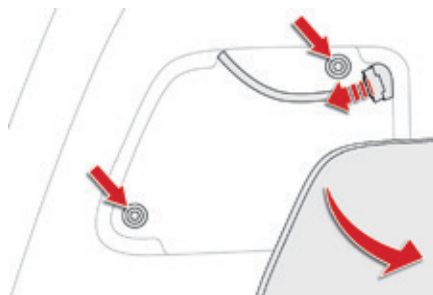

## Direction indicators and brake lamps (on the wings)

- ☞ Open the boot then remove the access cover.
- ☞ Disconnect the lamp connector.
- ☞ Remove the two lamp fixing nuts.

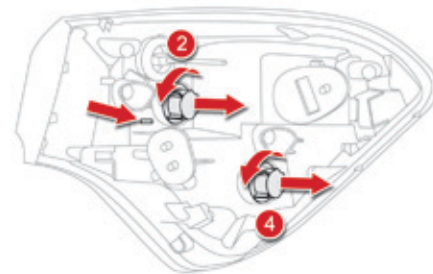

- ☞ Carefully remove the lamp unit from outside. The retaining clips unclip automatically.
- ☞ Turn the bulb holder a quarter of a turn and change the bulb.

For reassembly, carry out these operations in reverse order.

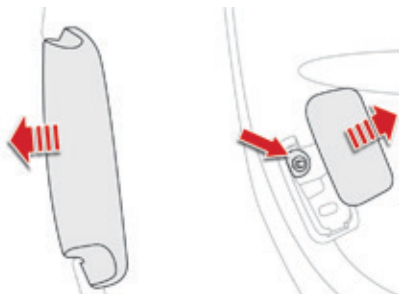

### Reversing lamp (tailgate)

- ☞ Open the tailgate.
- ☞ Unclip the skirt of the lamp.
- ☞ Remove the access cover and the lamp fixing nut.

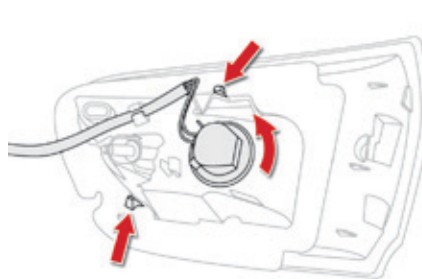

- ☞ Carefully remove the lamp from the outside. The retaining clips unclip automatically.
- ☞ Turn the bulb holder a quarter of a turn and replace the bulb.

For reassembly, carry out these operations in reverse order.

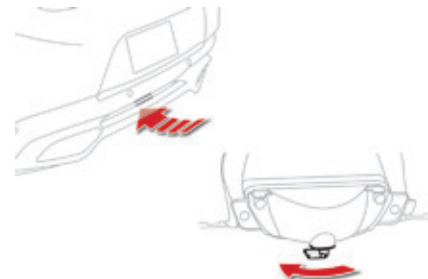

### Foglamp

Access is by passing a hand under the bumper.

- ☞ Turn the bulb holder a quarter of a turn and pull it out.
- ☞ Change the bulb.

To refit, carry out these operations in reverse order.

You can also contact a CITROËN dealer or a qualified workshop for the replacement of these bulbs.

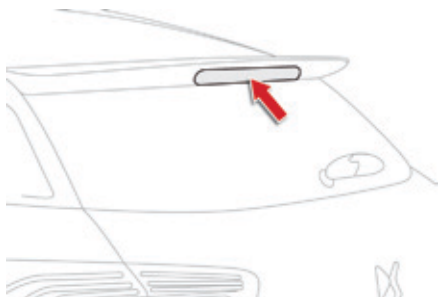

### **Third brake lamp (light emitting diodes - LEDs)**

Contact a CITROËN dealer or qualified workshop.

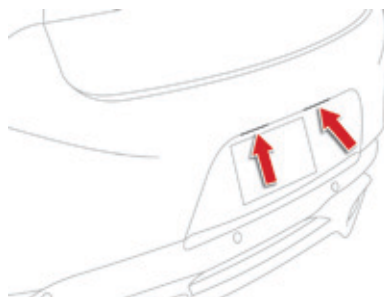

### **Number plate lamps**

- ☞ Insert a thin screwdriver into the slot in the lens.
- ☞ Push it outwards to unclip it.
- ☞ Remove the lens.
- ☞ Pull the bulb out and change it.

# Changing a fuse

## Access to tooling

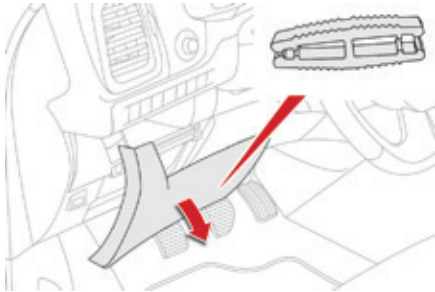

The fuse extraction tweezers are fitted to the back of the dashboard fusebox cover.

For access to it:

- ☞ remove the cover completely and turn it over,
- ☞ remove the tweezers.

## Changing a fuse

Before changing a fuse, it is necessary to:

- ☞ identify the cause of the failure and correct it,
- ☞ switch off all electrical consumers,
- ☞ immobilise the vehicle and switch off the ignition,
- ☞ identify the failed fuse using the allocation tables and diagrams presented on the following pages.

To remove or fit a fuse, it is essential to:

- ☞ use the special tweezers to extract the fuse from its housing and check the condition of its filament.
- ☞ always replace the failed fuse with a fuse of the same rating (same colour); a fuse of different rating could cause a fault (risk of fire).

If the fault recurs after replacing a fuse, have the electrical system checked by a CITROËN dealer or a qualified workshop.

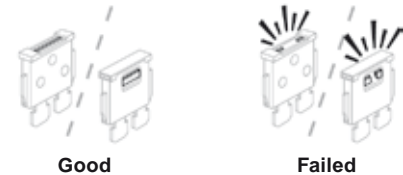

Good

Failed



Tweezer

**!** The replacement of a fuse not mentioned in the tables below could cause a serious malfunction of your vehicle. Contact a CITROËN dealer or a qualified workshop.



## **Installing electrical accessories**

Your vehicle's electrical system is designed to operate with standard or optional equipment.

Before installing other electrical equipment or accessories on your vehicle, contact a CITROËN dealer or a qualified workshop.



CITROËN will not accept responsibility for the cost incurred in repairing your vehicle or for rectifying malfunctions resulting from the installation of accessories not supplied and not recommended by CITROËN and not installed in accordance with its instructions, in particular when the combined consumption of all of the additional equipment connected exceeds 10 milliamperes.



## Dashboard fuses

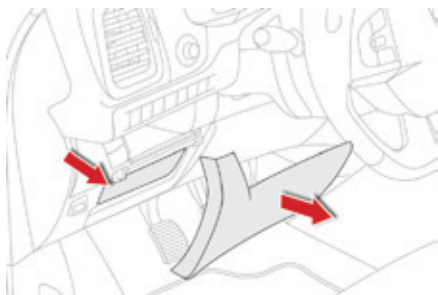

The fusebox is placed in the lower dashboard (left-hand side).

### Access to the fuses

☞ See the "Access to tooling" section.



## Table of fuses

Fuse N°	Rating (A)	Functions
<b>F6 A or B</b>	<b>15</b>	Audio system.
<b>F8</b>	<b>3</b>	Alarm.
<b>F13</b>	<b>10</b>	Front cigarette lighter, front 12 V socket.
<b>F14</b>	<b>10</b>	Rear 12 V socket.
<b>F16</b>	<b>3</b>	Rear map reading lamps.
<b>F17</b>	<b>3</b>	Courtesy mirror.
<b>F28 A or B</b>	<b>15</b>	Audio system.
<b>F30</b>	<b>20</b>	Rear wiper.
<b>F32</b>	<b>10</b>	Audio amplifier.

## Engine compartment fuses

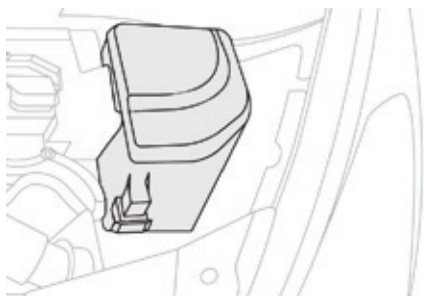

The fusebox is placed in the engine compartment near the battery.

### Access to the fuses

- ☞ Unclip the cover.
- ☞ Change the fuse.

For information on the special requirements and precautions to take before changing a fuse, refer to the start of this section.

- ☞ When you have finished, close the cover carefully to ensure correct sealing of the fusebox.

## Table of fuses

Fuse N°	Rating (A)	Functions
F20	15	Front / rear screenwash pump.
F21	20	Headlamp wash pump.
F22	15	Horn.
F23	15	Right-hand main beam headlamp.
F24	15	Left-hand main beam headlamp.
F27	5	Left hand lamp mask.
F28	5	Right hand lamp mask.

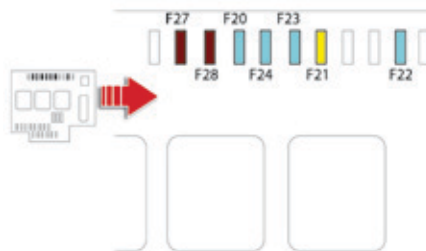





# 12 V battery

Procedure for starting the engine using another battery or charging a discharged battery.

## General points

### Lead-acid starter batteries

 Batteries contain harmful substances such as sulphuric acid and lead. They must be disposed of in accordance with regulations and must not, in any circumstances, be discarded with household waste. Take used remote control batteries and vehicle batteries to a special collection point.

 Versions equipped with Stop & Start are fitted with a 12 V lead-acid battery of specific technology and specification. Its replacement should be carried out only by a CITROËN dealer or a qualified workshop.

 Protect your eyes and face before handling the battery. All operations on the battery must be carried out in a well ventilated area and away from naked flames and sources of sparks, so as to avoid the risk of explosion or fire. Wash your hands afterwards.

 If your vehicle has an automatic gearbox, do not try to start the engine by pushing the vehicle.

## Access to the battery

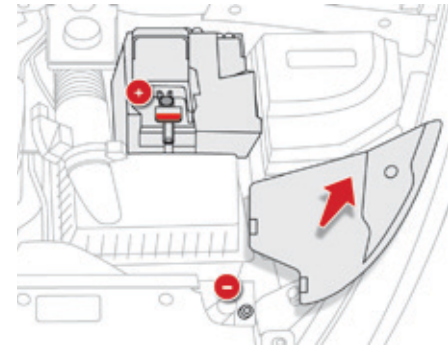

The battery is located under the bonnet.

To gain access to it:

- ☞ open the bonnet using the interior release lever, then the exterior safety catch,
- ☞ raise the plastic cover on the (+) terminal.

The battery (-) terminal is not accessible.

A remote earth point is provided at the front of the vehicle.

For access to it:

- ☞ unclip the plastic cover, located alongside the left-hand headlamp.

## Starting using another battery

When your vehicle's battery is discharged, the engine can be started using a slave battery (external or on another vehicle) and jump lead cables or a battery booster.

- ⚠ Never try to start the engine by connecting a battery charger. Never use a 24 V or higher battery booster. First check that the slave battery has a nominal voltage of 12 V and a capacity at least equal to that of the discharged battery. The two vehicles must not be in contact with each other. Switch off the electrical consumers on both vehicles (audio system, wipers, lighting, ...). Ensure that the jump lead cables do not pass close to moving parts of the engine (cooling fan, belts, ...). Do not disconnect the (+) terminal when the engine is running.

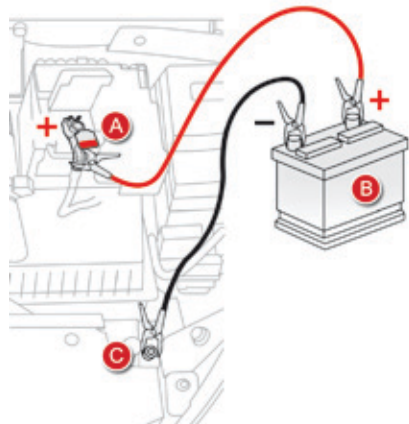

- ☞ Raise the plastic cover on the (+) terminal, if your vehicle has one.
- ☞ Connect the red cable to the positive terminal (+) of the flat battery **A** (at the metal elbow) then to the positive terminal (+) of the slave battery **B** or the booster.
- ☞ Connect one end of the green or black cable to the negative terminal (-) of the slave battery **B** or the booster (or earth point on the other vehicle).

- ☞ Connect the other end of the green or black cable to the earth point **C** on the broken down vehicle.
- ☞ Start the engine of the vehicle with the good battery and leave it running for a few minutes.
- ☞ Operate the starter on the broken down vehicle and let the engine run. If the engine does not start straight away, switch off the ignition and wait a few moments before trying again.
- ☞ Wait until the engine returns to idle then disconnect the jump lead cables in the reverse order.
- ☞ Refit the plastic cover to the (+) terminal, if your vehicle has one.
- ☞ Allow the engine to run for at least 30 minutes, by driving or with the vehicle stationary, so that the battery reaches an adequate state of charge.

- ⓘ Some functions, including Stop & Start, are not available if the battery is not sufficiently charged.

## Charging the battery using a battery charger

For optimum service life of the battery, it is essential to maintain an adequate state of charge.

In some circumstances it may be necessary to charge the battery:

- if you use your vehicle essentially for short journeys,
- if the vehicle is to be taken off the road for several weeks.

Contact a CITROËN dealer or a qualified workshop.

- ⚠ If you envisage charging your vehicle's battery yourself, use only a charger compatible with lead-acid batteries of a nominal voltage of 12 V.



If this label is present, it is essential to use only a 12 V charger, to avoid causing irreversible damage to the electrical components related to the Stop & Start system.

- ⚠ Follow the instructions for use provided by the manufacturer of the charger. Never reverse polarities.

- ℹ It is not necessary to disconnect the battery.

- ☞ Switch off the ignition.
- ☞ Switch off all electrical consumers (audio system, lighting, wipers, ...).
- ☞ Switch off the charger **B** before connecting the cables to the battery, so as to avoid any dangerous sparks.
- ☞ Ensure that the charger cables are in good condition.
- ☞ Connect the charger **B** cables as follows:
  - the positive (+) red cable to the (+) terminal of the battery **A**,
  - the negative (-) black cable to the earth point **C** on the vehicle.
- ☞ At the end of the charging operation, switch off the charger **B** before disconnecting the cables from the battery **A**.

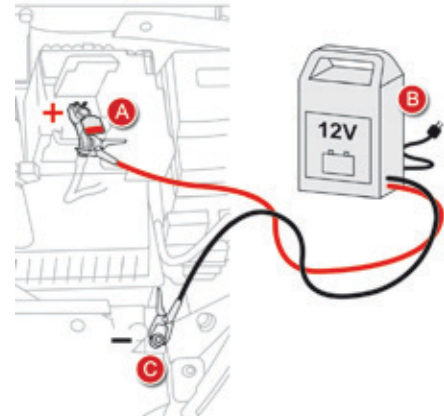

- ⚠ Never try to charge a frozen battery. If the battery has been frozen, have it checked by a CITROËN dealer or a qualified workshop, who will check that the internal components have not been damaged and the casing is not cracked, which could cause a leak of toxic and corrosive acid.

## Disconnecting the battery

In order to maintain an adequate state of charge for starting the engine, it is recommended that the battery be disconnected if the vehicle is taken out of service for a long period.

Wait 2 minutes after switching off the ignition before disconnecting the battery.

- ☞ close the windows and the doors before disconnecting the battery,
- ☞ switch off all electrical consumers (audio system, wipers, lighting, ...),
- ☞ switch off the ignition and wait for four minutes.

Having exposed the battery, it is only necessary to disconnect the (+) terminal.

### Quick release terminal

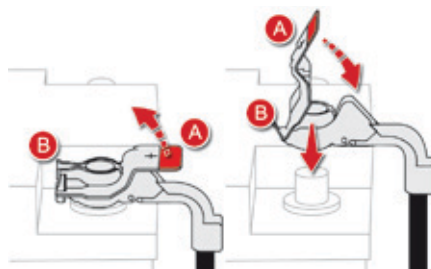

### Disconnecting the (+) terminal

- ☞ Raise the lever **A** fully to release the clamp **B**.

### Reconnecting the (+) terminal

- ☞ Position the open clamp **B** of the cable on the positive post (+) of the battery.
- ☞ Press down on the clamp to position it correctly on the battery post.
- ☞ Lock the clamp by lowering the lever **A**.



Do not force the lever as locking will not be possible if the clamp is not positioned correctly; start the procedure again.

### Following reconnection of the battery

After reconnecting the battery, switch on the ignition and wait 1 minute before starting to allow initialisation of the electronic systems. However, if minor problems persist following this operation, contact a CITROËN dealer or a qualified workshop.

Referring to the corresponding section, you must yourself reinitialise or reset certain systems, such as:

- the remote control or electronic key (depending on version),
- the electric blind(s),
- the electric windows
- the date and time,
- the radio preset stations.



The Stop & Start system may not be operational during the trip following the first engine start.

In this case, the system will only be available again after a continuous period of immobilisation of the vehicle, a period which depends on the ambient temperature and the state of charge of the battery (up to about 8 hours).

## Load reduction mode

System which manages the use of certain functions according to the level of charge remaining in the battery.

When the vehicle is being driven, the load reduction function temporarily deactivates certain functions, such as the air conditioning, the heated rear screen...

The deactivated functions are reactivated automatically as soon as conditions permit.

## Energy economy mode

System which manages the duration of use of certain functions to conserve a sufficient level of charge in the battery.

After the engine has stopped, you can still use functions such as the audio and telematics system, windscreen wipers, dipped beam headlamps, courtesy lamps, etc. for a maximum combined duration of about forty minutes.

### Switching to economy mode

A message then appears in the instrument panel screen indicating that the vehicle has switched to economy mode and the active functions are put on standby.

If a telephone call is being made at this time, it will be maintained for around 10 minutes with the Bluetooth hands-free system of your audio system.

### Exiting economy mode

These functions are reactivated automatically next time the vehicle is driven.

In order to restore the use of these functions immediately, start the engine and let it run:

- for less than ten minutes, to use the equipment for approximately five minutes,
- for more than ten minutes, to use the equipment for up to approximately thirty minutes.

Let the engine run for the duration specified to ensure that the battery charge is sufficient.

Do not repeatedly and continuously restart the engine in order to charge the battery.



A flat battery prevents the engine from starting.

For more information on the battery, refer to the corresponding section.

# Changing a wiper blade

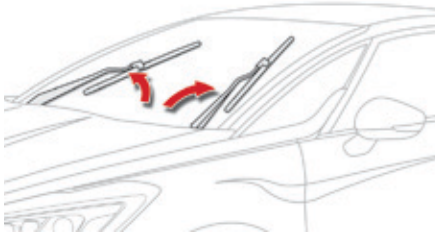

## Before removing a front wiper blade

- ☞ Within one minute after switching off the ignition, operate the wiper stalk to position the wiper blades vertically on the windscreen.

## Removing

- ☞ Raise the corresponding wiper arm.
- ☞ Unclip the wiper blade and remove it.

## Fitting

- ☞ Put the corresponding new wiper blade in place and clip it.
- ☞ Fold down the wiper arm carefully.

## After fitting a front wiper blade

- ☞ Switch on the ignition.
- ☞ Operate the wiper stalk again to park the wiper blades.

# Towing the vehicle

Procedure for having your vehicle towed or for towing another vehicle using a removable towing eye.

## Access to the tools

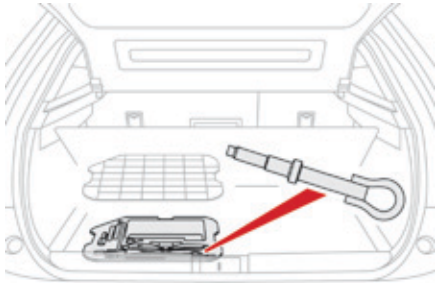

The towing eye is stowed in the boot under the floor.

To gain access to it:

- ☞ open the boot,
- ☞ raise the boot floor,
- ☞ take out the towing eye, located in the storage well.

## 🚫 General recommendations

Observe the legislation in force in your country.

Ensure that the weight of the towing vehicle is higher than that of the towed vehicle.

The driver must remain at the wheel of the towed vehicle and must have a valid driving licence.

When towing a vehicle with all four wheels on the ground, always use an approved towing arm; rope and straps are prohibited.

The towing vehicle must move off gently.

When towing a vehicle with the engine off, there is no longer any power assistance for braking or steering.

In the following cases, you must always call on a professional recovery service:

- vehicle broken down on a motorway or fast road,
- four-wheel drive vehicle,
- when it is not possible to put the gearbox into neutral, unlock the steering, or release the parking brake,
- towing with only two wheels on the ground,
- where there is no approved towing arm available...

## Towing your vehicle

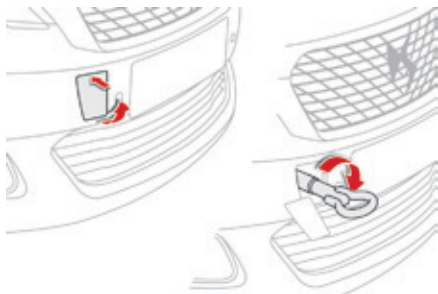

- ☞ On the front bumper, unclip the cover by pressing at the top to disengage the securing lugs.
- ☞ Screw the towing eye in fully.
- ☞ Install the towing arm.



☞ Place the gear lever in neutral (position **N** with an automatic gearbox). Failure to follow this advice could result in damage to certain systems (braking, transmission...) and the absence of braking assistance the next time the engine is started.

- ☞ Unlock the steering and release the parking brake.
- ☞ Switch on the hazard warning lamps on both vehicles.
- ☞ Move off gently and drive at low speed and for a short distance only.

## Towing another vehicle

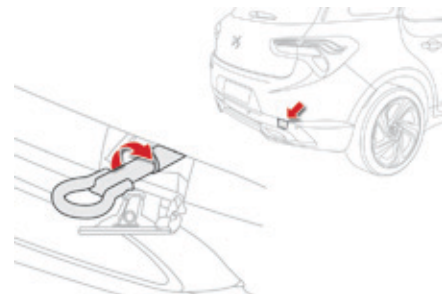

- ☞ On the rear bumper, unclip the cover by levering at the left with the point of the towing eye.
- ☞ Screw the towing eye in fully.
- ☞ Install the towing arm.
- ☞ Switch on the hazard warning lamps on both vehicles.
- ☞ Move off gently and drive at low speed and for a short distance only.



## Towing a trailer



Your vehicle is primarily designed for transporting people and luggage, but it may also be used for towing a trailer.

**i** When not towing a trailer, remove the quickly-detachable tow ball before driving, so as to avoid masking the central rear lamp.

**i** We recommend the use of genuine CITROËN towbars and their harnesses that have been tested and approved from the design stage of your vehicle, and that the fitting of the towbar is entrusted to a CITROËN dealer or a qualified workshop.  
If the towbar is not fitted by a CITROËN dealer, it must still be fitted in accordance with the vehicle manufacturer's instructions.

**!** Driving with a trailer places greater demands on the towing vehicle and the driver must take particular care. For more advice on driving when towing, refer to the corresponding section.

**i** For more information on weights (and the towed loads which apply to your vehicle) refer to the corresponding section.

# Fitting roof bars

When fitting transverse roof bars, take care to position them correctly:

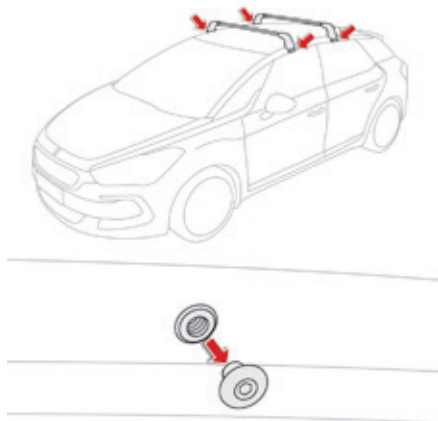

- 🔧 Remove the cap using an allen™ key.
- 🔧 Put the bars into position then fit and tighten the securing screws.

⚠️ Use accessories recommended by CITROËN observing the manufacturer's recommendations and fitting instructions so as to avoid the risk of damaging the body (deformation, scratches, ...).

ℹ️ Maximum authorised load evenly distributed on the roof bars, for a loading height not exceeding 40 cm (with the exception of bicycle carriers): **70 kg**.  
If the height exceeds 40 cm, adapt the speed of the vehicle to the profile of the road to avoid damaging the roof bars and the fixings on the roof.

⚠️ Be sure to refer to national legislation in order to comply with the regulations for transporting objects which are longer than the vehicle.



## Advice on care and maintenance

Recommendations on the care and maintenance your vehicle are given in the maintenance and warranty guide.

### Customising stickers

These customising parts are self-adhesive stickers, treated to give good resistance to ageing and tearing.

They are intended for customising the body. Available also as accessories, we recommend that you have them fitted by a CITROËN dealer or a qualified workshop.

When washing your vehicle, keep the end of a high-pressure lance at least 30 centimetres from the stickers.

### Headlamps and lamps

The headlamps have polycarbonate lenses, finished with a protective lacquer.

Do not clean them with a dry or abrasive cloth, nor with detergent or solvent products.

Use a sponge and soapy water.

The use of a high pressure jet wash for cleaning the headlamps, lamps and their surrounds may damage the lacquer and seals.

Observe the recommendations on pressure and distance for jet washing.

First clean persistent stains with a sponge and warm soapy water.

### Leather

Leather is a natural product. Appropriate regular care and cleaning is essential for its durability.

Refer to your vehicle's maintenance and warranty guide for information on the special precautions to observe.



We strongly advise against cleaning your vehicle in a high pressure car wash.

# Accessories

A wide range of accessories and genuine parts is available from the CITROËN dealer network. These accessories and parts are all suitable for your vehicle and benefit from CITROËN's recommendation and warranty.

## "Comfort":

door deflectors, side window blinds, rear screen blind, isotherm module, coat hanger fixed to head restraint, mobile reading lamp, mirror for caravan, parking sensors, scented air freshener, cigarette lighter, ...

## "Transport systems":

child seats and booster cushions, boot carpet, boot liner, boot net, boot spacers, transverse roof bars, bicycle carrier, ski carrier, roof boxes, towbars, wiring harnesses...



If a towbar and wiring harness are fitted outside the CITROËN dealer network, the installation must be done using the vehicle's electrical pre-equipment and fitted following the manufacturer's recommendations.

## "Styling":

aluminium pedals, aluminium foot rest, alloy wheels, chrome mirror shells, ...

## "Security and safety":

anti-intrusion alarm, anti-tilt unit, stolen vehicle tracking system, child seats and booster cushions, dog guard, breathalyser, first aid kit, fire extinguisher, warning triangle, belt cutter/glass breaker, high visibility vest, wheel security bolts, snow chains, snow socks, ...

## "Protection":

mats\*, mud flaps, bumper protection strips, boot sill protector, vehicle cover...



The rear bodywork has been designed to avoid spray.

- \* To avoid any risk of jamming the pedals:
  - ensure that mats are correctly positioned and secured,
  - never fit one mat on top of another.

## "Multimedia":

Bluetooth hands-free system, portable satellite navigation system, mapping update CD, driving assistance systems, portable video screen, portable video support bracket, multimedia system support, 230 V/50 Hz socket, 230 V/12 V adaptor, mobile phone charger compatible with iPhone®, Wi-Fi on board, ...

By visiting a CITROËN dealer you can also obtain cleaning and maintenance products (interior and exterior) - including ecological products in the "TECHNATURE" range, products for topping up (screenwash...), paint touch-up pens and aerosols for the exact colour of your vehicle, refills (sealant cartridge for the temporary puncture repair kit...), ...

### **Installation of radio communication transmitters**

Before installing any after-market radio communication transmitter, you can contact a CITROËN dealer for the specification of transmitters which can be fitted (frequency, maximum power, aerial position, specific installation requirements), in line with the Vehicle Electromagnetic Compatibility Directive (2004/104/EC).

 Depending on the legislation in force in the country, certain safety equipment may be compulsory: high visibility safety vests, warning triangles, breathalyzers, spare bulbs, spare fuses, fire extinguisher, first aid kit, mud flaps at the rear of the vehicle.

 The fitting of electrical equipment or accessories which are not recommended by CITROËN may result in a failure of your vehicle's electronic system and excessive electrical consumption. Contact a CITROËN dealer for information on the range of recommended equipment and accessories.

**009**

Checks



DS 5

## TOTAL & DS

### A DYNAMIC PARTNERSHIP, DIRECTED TOWARDS THE FUTURE.

For more than 45 years, TOTAL and DS have shared common values: excellence, creativity and technological innovation.

It is in this same spirit that TOTAL has developed a range of TOTAL QUARTZ lubricants adapted to DS engines, making them even more fuel efficient and protective of the environment.

**Choose TOTAL QUARTZ lubricants  
for servicing your vehicle,  
this is your assurance of optimum  
durability and performance from your  
engine.**



DS AUTOMOBILES

DS prefers **TOTAL**



**TOTAL**



# Fuel tank

Capacity of the tank: approximately 60 litres.

## Opening



- ☞ Press the switch

This switch remains active for a few minutes after switching off the ignition. If necessary, switch the ignition on again to reactivate it.



With Stop & Start, never refuel with the system in STOP mode; you must switch off the ignition with the START/STOP button.

## Refuelling

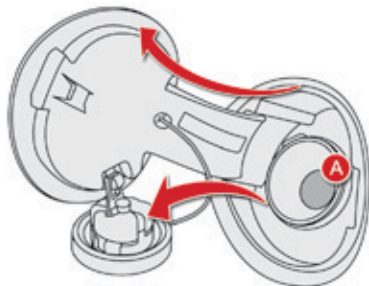

Additions of fuel must be of at least 5 litres to be registered by the fuel gauge.

Opening the filler cap may result in an inrush of air. This vacuum is entirely normal and results from the sealing of the fuel system.

- ☞ Take care to select the pump that delivers the correct fuel type for your vehicle's engine (reminder on a label on the inside of the filler flap).
- ☞ Open the filler cap by turning it a 1/4 turn to the left.
- ☞ Remove the filler cap and hang it on its carrier (on the filler flap).

- ☞ Introduce the nozzle and push it in fully (pushing open the non-return valve **A** on petrol vehicles).
- ☞ Fill the tank (don't continue past the third cut-off of the nozzle, as this may cause malfunctions).
- ☞ Refit the filler cap turning it a 1/4 turn to the right.
- ☞ Push the filler flap to close it.

Your vehicle is fitted with a catalytic converter which reduces harmful emissions in the exhaust gas.

The filler neck is narrower and allows only petrol nozzles to be used.

**For a petrol engine, the use of unleaded fuel is compulsory.**



**If you have put in the wrong fuel for your vehicle, you must have the tank drained and refilled with the correct fuel before you start the engine.**

## Low fuel level



When the low fuel level in the tank is reached, this warning lamp comes on in the instrument panel, accompanied by an audible warning and a message in the instrument panel screen.

When it first comes on, around 6 litres of fuel remain in the tank.

Until sufficient fuel has been added, this warning lamp appears every time the ignition is switched on, accompanied by an audible signal and a message. This audible signal and message are repeated with increasing frequency as the fuel level drops and approaches "0".

You must refuel as soon as possible to avoid running out.

## Fuel supply cut-off

Your vehicle is equipped with a safety device which cuts off the fuel supply in the event of a collision.

## Fuel used for petrol engines

The petrol engines are compatible with E10 bio-petrol (containing 10 % ethanol), conforming to European standards EN 228 and EN 15376.

E85 type fuels (containing up to 85 % ethanol) are reserved exclusively for vehicles marketed for the use of this type of fuel (BioFlex vehicles). The quality of the ethanol must comply with European standard EN 15293.





## Fuel used for Diesel engines

The Diesel engines are compatible with biofuels available at the pumps which meet current and future European standards:

- Diesel fuel that meets standard EN 590 mixed with a biofuel that meets standard EN 14214,
- Diesel fuel that meets standard EN16734 mixed with a biofuel that meets standard EN14214 (possibly containing up to 10 % Fatty Acid Methyl Ester),
- Paraffinic Diesel fuel that meets standard EN15940 mixed with a biofuel that meets standard EN14214 (possibly containing up to 7 % Fatty Acid Methyl Ester).

The use of B20 or B30 fuel meeting standard EN16709 is possible in your Diesel engines. However, this use, even occasional, requires strict application of the special servicing conditions referred to as "Arduous conditions".

For more information, contact a CITROËN dealer or a qualified workshop.

The use of any other type of (bio)fuel (vegetable or animal oils, pure or diluted, domestic fuel...) is strictly prohibited (risk of damage to the engine and fuel system).

Only the use of Diesel fuel additives that meet the standard B715000 is authorised.



DIESEL

## Misfuel prevention (Diesel)\*

Mechanical device which prevents filling the tank of a Diesel vehicle with petrol. It avoids the risk of engine damage that can result from filling with the wrong fuel.

Located in the filler neck, the misfuel prevention device appears when the filler cap is removed.

### Operation

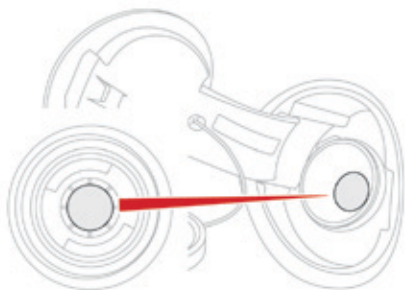

When a petrol filler nozzle is introduced into the fuel filler neck of your Diesel vehicle, it comes into contact with the flap. The system remains closed and prevents filling.

**Do not persist but introduce a Diesel type filler nozzle.**

**i** It remains possible to use a fuel can to fill the tank.

In order to ensure a good flow of fuel, do not place the nozzle of the fuel can in direct contact with the flap of the misfuel prevention device and pour slowly.

### **i** Travelling abroad

As Diesel fuel pump nozzles may be different in other countries, the presence of the misfuel prevention device may make refuelling impossible. Not all Diesel vehicles are fitted with misfuel protection, so before travelling abroad, we recommend that you check with the CITROËN dealer network, whether your vehicle is suitable for the fuel pumps in the country in which you intend to travel.

\* Depending on the country of sale.

# Bonnet

- ⚠ Before doing anything under the bonnet, switch off the Stop & Start system to avoid any risk of injury resulting from an automatic change to START mode.



- ⚠ Because of the presence of electrical equipment under the bonnet, it is recommended that exposure to water (rain, washing, ...) be limited.

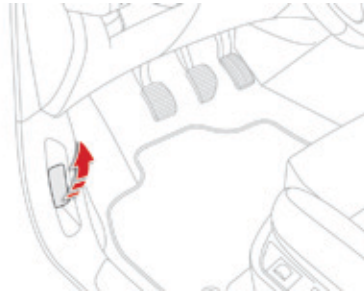

## Opening

- ☞ **From inside:** pull the release lever, located on the left below the dashboard, towards you.

- ⚠ **The cooling fan may start after switching off the engine: take care with articles and clothing that might be caught by the fan blades.**

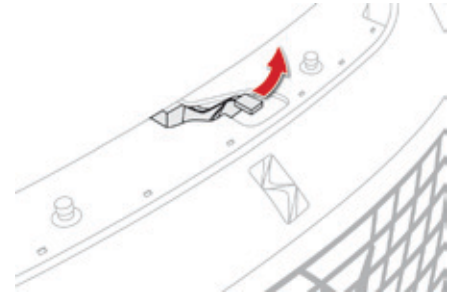

- ☞ **From the outside:** lift the safety catch and raise the bonnet.  
A bonnet strut opens the bonnet and holds it open.

## Closing

- ☞ Lower the bonnet and release it at the end of its travel.
- ☞ Check that it is latched correctly.

## Petrol engines

1. Power steering fluid reservoir.
2. Screenwash and headlamp wash fluid reservoir.
3. Coolant header tank.
4. Brake fluid reservoir.
5. Battery / Fuses.
6. Fusebox.
7. Remote earth point (-).
8. Air filter.
9. Engine oil dipstick.
10. Engine oil filler cap.

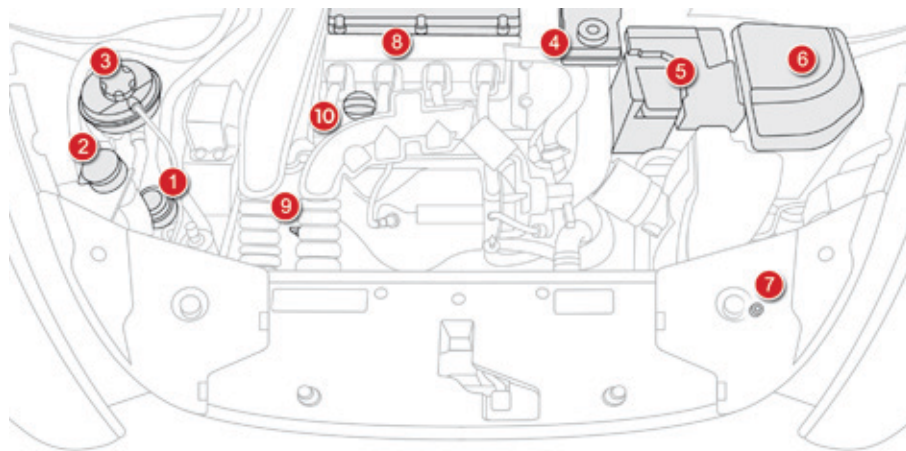

## Diesel engines

1. Power steering fluid reservoir.
2. Screenwash and headlamp wash fluid reservoir.
3. Coolant header tank.
4. Brake fluid reservoir.
5. Battery / Fuses.
6. Fusebox.
7. Remote earth point (-).
8. Air filter.
9. Engine oil dipstick.
10. Engine oil filler cap.

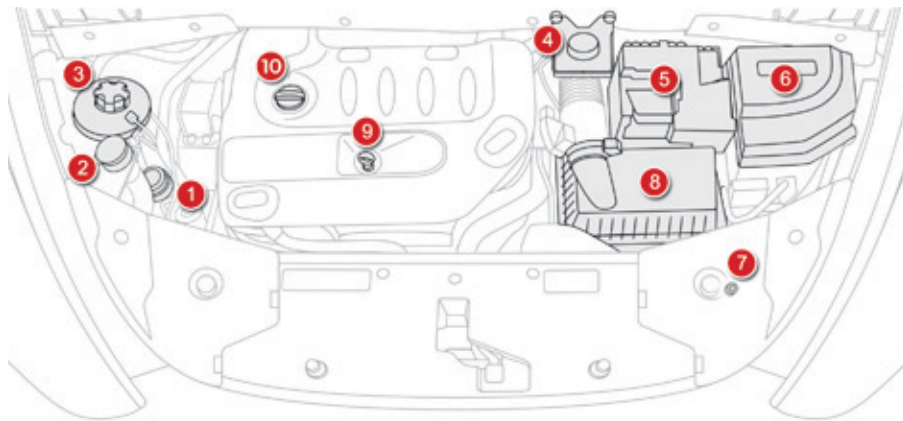

The Diesel fuel system operates under high pressure:

- Never carry out any work on this system yourself.
- HDi engines make use of advanced technology.

All maintenance and repairs require specially trained staff, which only a CITROËN dealer can provide.

# Running out of fuel (Diesel)

On vehicles fitted with Diesel engines, the fuel system must be primed if you run out of fuel.



For more information on the Diesel misfuel prevention device, refer to the corresponding section.



If the engine does not start first time, don't keep trying but start the procedure again from the beginning.

## BlueHDi engines

- ☞ Fill the fuel tank with at least five litres of Diesel.
- ☞ Switch on the ignition (without starting the engine).
- ☞ Wait around 6 seconds and switch off the ignition.
- ☞ Repeat the operation 10 times.
- ☞ Operate the starter to run the engine.



# Checking levels

Check all of these levels regularly, in line with the manufacturer's service schedule. Top them up if necessary, unless otherwise indicated. If a level drops significantly, have the corresponding system checked by a CITROËN dealer or a qualified workshop.

- ⚠ Take care when working under the bonnet, as certain areas of the engine may be extremely hot (risk of burns) and the cooling fan could start at any time (even with the ignition off).

## Engine oil level



The check is carried out either when the ignition is switched on using the oil level indicator in the instrument panel for vehicles so equipped, or using the dipstick.

- i To ensure that the reading is correct, your vehicle must be parked on a level surface with the engine having been off for more than 30 minutes.

It is normal to top up the oil level between two services (or oil changes). CITROËN recommends that you check the level, and top up if necessary, every 3 000 miles (5 000 kms).

## Checking using the dipstick

The location of the dipstick is shown in the corresponding underbonnet layout view.

- ☞ Take the dipstick by its coloured grip and remove it completely.
- ☞ Wipe the end of the dipstick using a clean non-fluffy cloth.
- ☞ Refit the dipstick and push fully down, then pull it out again to make the visual check: the correct level is between the marks **A** and **B**.

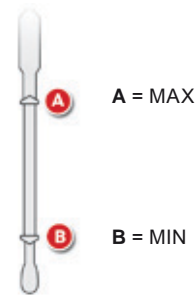

If you find that the level is above the **A** mark or below the **B** mark, **do not start the engine**.

- If the level is above the **MAX** mark (risk of damage to the engine), contact a CITROËN dealer or a qualified workshop.
- If the level is below the **MIN** mark, you must top up the engine oil.

## Oil grade

Before topping-up the oil or changing the oil, check that the oil is the correct grade for your engine and conforms to the manufacturer's recommendations.

## Topping-up the engine oil level

The location of the oil filler cap is shown in the corresponding underbonnet layout view.

- 🔧 Unscrew the oil filler cap to reveal the filler aperture.
- 🔧 Add oil in small quantities, avoiding any spills on engine components (risk of fire).
- 🔧 Wait a few minutes before checking the level again using the dipstick.
- 🔧 Add more oil if necessary.
- 🔧 After checking the level, carefully refit the oil filler cap and the dipstick in its tube.

After topping-up the oil, the check when switching on the ignition with the oil level indicator in the instrument panel is not valid during the 30 minutes after topping up.

## Engine oil change

Refer to the manufacturer's service schedule for details of the interval for this operation.

 In order to maintain the reliability of the engine and emission control system, never use additives in the engine oil.

## Brake fluid level



The brake fluid level should be close to the "MAX" mark. If it is not, check the brake pad wear.

## Changing the fluid

Refer to the manufacturer's service schedule for details of the interval for this operation.

## Fluid specification

The brake fluid must conform to the manufacturer's recommendations.

## Power steering fluid level



The power steering fluid level should be close to the "MAX" mark. With the engine cold, unscrew the cap to check the level.

## Coolant level



The coolant level should be close to the "MAX" mark but should never exceed it.

When the engine is warm, the temperature of the coolant is regulated by the fan.

**The cooling fan may start after switching off the engine: take care with articles and clothing that might be caught by the fan blades.**



In addition, as the cooling system is pressurised, wait at least one hour after switching off the engine before carrying out any work.

To avoid any risk of scalding, unscrew the cap by two turns to allow the pressure to drop. When the pressure has dropped, remove the cap and top up the level.

## Fluid specification

The coolant must conform to the manufacturer's recommendations.

## Screenwash / headlamp wash level

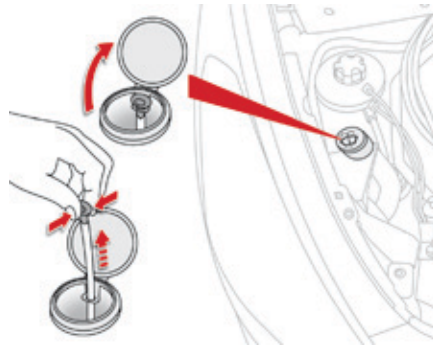

To check the level or top up the fluid on vehicle fitted with headlamp washers, immobilise the vehicle and switch of the engine.

- ☞ Before opening the bonnet, ensure that the engine has completely stopped.

- ☞ Open the screenwash reservoir filler cap.
- ☞ Take and pinch the level gauge to block its breather.
- ☞ Remove the gauge completely from the reservoir to read the level in the transparent section.
- ☞ Top up if necessary.
- ☞ Refit the filler cap to the reservoir and close the bonnet.

## Specification of the fluid

To ensure optimum cleaning and to avoid freezing, the fluid should never be topped up or replaced by plain water.

In wintry conditions, the use of an ethyl alcohol or methanol base fluid is recommended.

## Diesel additive level (Diesel engine with particle filter)

### SERVICE

A low additive level is indicated by illumination of this warning lamp, accompanied by an audible warning and a message in the instrument panel screen.

### Topping up

This additive must be topped up by a CITROËN dealer or a qualified workshop without delay.

## Used products



Avoid prolonged contact of used oil or fluids with the skin.

Most of these fluids are harmful to health or indeed very corrosive.



Do not discard used oil or fluids into sewers or onto the ground.

Take used oil to a CITROËN dealer or a qualified workshop (France) or to an authorised waste disposal site.

# Checks

Unless otherwise indicated, check these components in accordance with the manufacturer's service schedule and according to your engine. Otherwise, have them checked by a CITROËN dealer or a qualified workshop.

## 12 V battery



The battery does not require any maintenance. However, check regularly that the terminals are correctly tightened and that the connections are clean.

When carrying out any operation on the 12 V battery, refer to the corresponding section for details of the precautions to be taken before starting work.



Versions equipped with Stop & Start are fitted with a 12 V lead-acid battery of specific technology and specification. Its replacement should be carried out only by a CITROËN dealer or a qualified workshop.

## Air filter and passenger compartment filter



Refer to the manufacturer's service schedule for details of the replacement intervals for these components.

Depending on the environment (e.g. dusty atmosphere) and the use of the vehicle (e.g. city driving), **replace them twice as often if necessary.**

A clogged passenger compartment filter may have an adverse effect on the performance of the air conditioning system and generate undesirable odours.

## Oil filter



Replace the oil filter each time the engine oil is changed. Refer to the manufacturer's service schedule for details of the replacement interval for this component.

## Particle filter (Diesel)

### SERVICE

The start of saturation of the particle filter is indicated by the temporary illumination of this warning lamp accompanied by a message in the multifunction screen.



As soon as the traffic conditions permit, regenerate the filter by driving at a speed of at least 40 mph (60 km/h) until the warning lamp goes off.

If the warning lamp stays on, this indicates a low additive level.

For more information on checking levels, refer to the corresponding section.

On a new vehicle, the first particle filter regeneration operations may be accompanied by a "burning" smell, which is perfectly normal.

Following prolonged operation of the vehicle at very low speed or at idle, you may, in exceptional circumstances, notice the emission of water vapour at the exhaust on acceleration. This does not affect the behaviour of the vehicle or the environment.

## Manual gearbox



The gearbox does not require any maintenance (no oil change). Refer to the manufacturer's service schedule for the checking interval for this component.

## Automatic gearbox



The gearbox does not require any maintenance (no oil change). Refer to the manufacturer's service schedule for details of the level checking interval for this component.

## Brake pads



Brake wear depends on the style of driving, particularly in the case of vehicles used in town, over short distances. It may be necessary to have the condition of the brakes checked, even between vehicle services. Unless there is a leak in the circuit, a drop in the brake fluid level indicates that the brake pads are worn.

## Brake disc wear



For information on checking brake disc wear, contact a CITROËN dealer or a qualified workshop.

## Electric parking brake



This system does not require any routine servicing. However, in the event of a problem, have the system checked by a CITROËN dealer or a qualified workshop.

For more information on the electric parking brake, refer to the corresponding section.



Only use products recommended by CITROËN or products of equivalent quality and specification. In order to optimise the operation of units as important as those in the braking system, CITROËN selects and offers very specific products. After washing the vehicle, dampness, or in wintry conditions, ice can form on the brake discs and pads: braking efficiency may be reduced. Make light brake applications to dry and defrost the brakes.

# AdBlue® additive and SCR system for BlueHDi Diesel engines

To assure respect for the environment and conformity with the new Euro 6 emissions standard, without adversely affecting the performance or fuel consumption of Diesel engines, CITROËN has taken the decision to equip its vehicles with an effective system that associates SCR (Selective Catalytic Reduction) with a particle filter (FAP) for the treatment of exhaust gases.

## Presentation of the SCR system

Using an additive called AdBlue® containing urea, a catalytic converter turns up to 85% of nitrous oxides (NOx) into nitrogen and water, which are harmless to health and the environment.

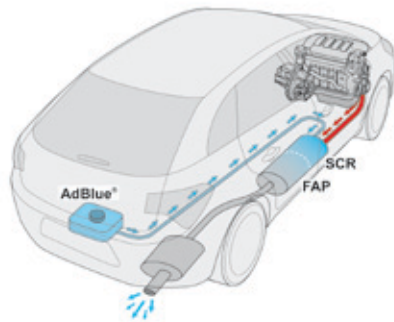

The AdBlue® additive is held in a special tank located under the boot at the rear of the vehicle. It has a capacity of 17 litres: this provides a driving range of about 12 500 miles (20 000 km), after which an alert is triggered warning you when the reserve remaining is enough for just 1 500 miles (2 400 km).

During each scheduled service of your vehicle by a CITROËN dealer or a qualified workshop, the AdBlue® additive tank is refilled in order to allow normal operation of the SCR system.

If the estimated mileage between two services is greater than 12 500 miles (20 000 km), we recommend that you go to a CITROËN dealer or a qualified workshop to have the necessary top-up carried out.



Once the AdBlue® tank is empty, a system required by regulations prevents starting of the engine. If the SCR is faulty, the level of emissions from your vehicle will no longer meet the Euro 6 standard: your vehicle becomes polluting. In the event of a confirmed fault with the SCR system, you must go to a CITROËN dealer or a qualified workshop as soon as possible: after a running distance of 650 miles (1 100 km), a system will be triggered automatically to prevent engine starting.

## Range indicators

Once the AdBlue® tank is on reserve or after detection of a fault with the SCR emissions control system, when the ignition is switched on, an indicator displays an estimate of the distance that can be covered, the range, before engine starting is prevented.

In the event of simultaneous system fault and low AdBlue® level, the shortest range figure is the one displayed.

### In the event of the risk of non-starting related to a lack of AdBlue®



The engine start prevention system required by regulations is activated automatically once the AdBlue® tank is empty.

#### Range greater than 1 500 miles (2 400 km)

When the ignition is switched on, no information on range is displayed automatically in the instrument panel.

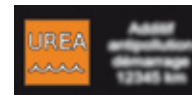
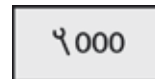

Pressing this button displays the driving range temporarily.

Above 3 000 miles (5 000 km), the value is not specified.



Remaining range between 350 and 1500 miles (600 and 2 400 km)

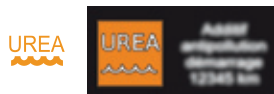

When switching on the ignition, the UREA warning lamp comes on, accompanied by an audible signal and the display of a message (e.g.: "Top up emissions additive: Starting prevented in 900 miles") indicating the remaining range expressed in miles or kilometres.

When driving, the message is displayed every 200 miles (300 km) until the additive tank has been topped-up.

Go to a CITROËN dealer or a qualified workshop to have the AdBlue® tank topped-up. You can also top-up the tank yourself.

For more information on topping-up the AdBlue® additive, refer to the corresponding section.

Remaining range between 0 and 350 miles (0 and 600 km)



When switching on the ignition, the SERVICE warning lamp comes on and the UREA warning lamp flashes, accompanied by an audible signal and the display of a message (e.g. "Top up emissions additive: Starting prevented in 350 miles") indicating the remaining range expressed in miles or kilometres.

When driving, the message is displayed every 30 seconds until the additive tank has been topped-up.

Go to a CITROËN dealer or a qualified workshop to have the AdBlue® tank topped-up. You can also top-up the tank yourself.

Otherwise you will not be able to restart your engine.

For more information on topping-up the AdBlue® additive, refer to the corresponding section.

Breakdown related to a lack of AdBlue® additive



When switching on the ignition, the SERVICE warning lamp comes on and the UREA warning lamp flashes, accompanied by an audible signal and the display of the message "Top up emissions additive: Starting prevented". The AdBlue® tank is empty: the system required by regulations prevents engine starting.



To be able to start the engine, we recommend that you call on a CITROËN dealer or a qualified workshop for the top-up required. If you carry out the top-up yourself, it is essential to add at least 3.8 litres of AdBlue® to the tank.

## In the event of a fault with the SCR emissions control system

 A system that prevents engine starting is activated automatically from 650 miles (1 100 km) after confirmation of a fault with the SCR emissions control system. Have the system checked by a CITROËN dealer or a qualified workshop as soon as possible.

### In the event of the detection of a fault



The UREA, SERVICE and diagnostic warning lamps comes on, accompanied by an audible signal and the display of the message "Emissions fault".

The alert is triggered when driving when the fault is detected for the first time, then when switching on the ignition for subsequent journeys, while the fault persists.

 If it is a temporary fault, the alert disappears during the next journey, after self-diagnosis of the SCR system.

### During an authorised driving phase (between 650 miles and 0 miles) (1 100 km and 0 km)



If a fault with the SCR system is confirmed (after 30 miles (50 km) covered with the permanent display of the message signalling a fault), the SERVICE and engine diagnostic warning lamps come on and the UREA warning lamp flashes, accompanied by an audible signal and the display of a message (e.g.: "Emissions fault: Starting prevented in 150 miles") indicating the remaining range express in miles or kilometres.

While driving, the message is displayed every 30 seconds while the fault with the SCR system persists.

The alert is repeated when switching on the ignition.

You should go to a CITROËN dealer or a qualified workshop as soon as possible. Otherwise, you will not be able to restart your engine.



## Starting prevented



Every time the ignition is switched on, the SERVICE and engine diagnostic warning lamps come on and the UREA warning lamp flashes, accompanied by an audible signal and the display of the message "Emissions fault: Starting prevented".

 You have exceeded the authorised driving limit: the starting prevention system inhibits engine starting.

To be able to start the engine, you must call on a CITROËN dealer or a qualified workshop.

## Freezing of the AdBlue® additive

The AdBlue® additive freezes at temperatures below around -11°C. The SCR system includes a heater for the AdBlue® tank, allowing you to continue driving in very cold conditions.

## Topping-up the AdBlue® additive

Filling the AdBlue® tank is an operation included in every routine service on your vehicle by a CITROËN dealer or a qualified workshop.

Nevertheless, given the capacity of the tank, it may be necessary to top-up the additive between services, more particularly if an alert (warning lamps and a message) signals the requirement.

You can go to a CITROËN dealer or a qualified workshop.

If you envisage topping-up yourself, please read the following warnings carefully.

### Precautions in use

The AdBlue® additive is an urea-based solution. This liquid is non-flammable, colourless and odourless (kept in a cool area). In the event of contact with the skin, wash the affected area with soap and water. In the event of contact with the eyes, wash (irrigate) the eyes with large amounts of water or with an eye wash solution for at least 15 minutes. If a burning sensation or irritation persists, get medical attention.

If swallowed, immediately wash out the mouth with clean water and then drink plenty of water. In certain conditions (high ambient temperature, for example), the risk of release of ammonia cannot be excluded: do not inhale the product. Ammonia vapour has an irritant effect on mucous membranes (eyes, nose and throat).



Keep AdBlue® out of the reach of children, in its original bottle. Never transfer AdBlue® to another container: it would lose its purity.

Use only AdBlue® additive that meets the ISO 22241 standard.



Never dilute the additive with water. Never pour the additive into the Diesel fuel tank.



**AdBlue®**

The supply in a non-drip bottle simplifies topping-up. You can obtain 1.89 litre (half a US gallon) bottles from a CITROËN dealer or a qualified workshop.



Never top-up from an AdBlue® dispenser reserved for heavy goods vehicles.



## Recommendations on storage

AdBlue® freezes at about  $-11^{\circ}\text{C}$  and deteriorates above  $25^{\circ}\text{C}$ . It is recommended that bottles be stored in a cool area and protected from direct sunlight.

Under these conditions, the additive can be kept for at least a year.

If the additive has frozen, it can be used once it has completely thawed out.



Never store bottles of AdBlue® in your vehicle.

## Procedure

Before topping-up, ensure that the vehicle is parked on a flat and level surface.

In wintry conditions, ensure that the temperature of the vehicle is above  $-11^{\circ}\text{C}$ .

Otherwise the AdBlue® may be frozen and so cannot be poured into its tank. Park your vehicle in a warmer area for a few hours to allow the top-up to be carried out.

- ☞ Press the START/STOP button to switch off the engine.

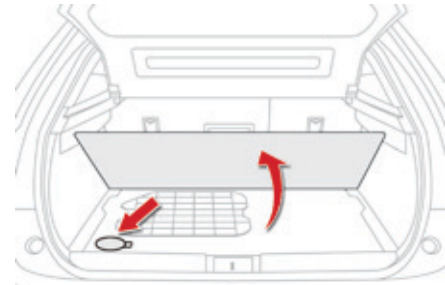

- ☞ Raise the boot floor for access to the AdBlue® tank. Use an object, such as a bag, to keep the left part up.



- ☞ Unclip the black plastic blanking plug using a lever.

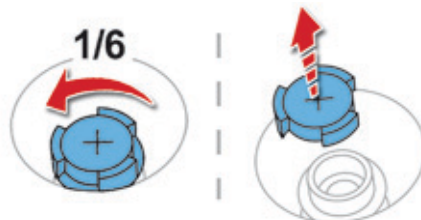



- ☞ Insert your fingers into the aperture and turn the blue cap a 6<sup>th</sup> of a turn anti-clockwise.
- ☞ Carefully lift off the cap, without dropping it.







- ☞ Obtain a bottle of AdBlue®. After first checking the use-by date, read carefully the instructions on use on the label before pouring the contents of the bottle into your vehicle's AdBlue® tank.





 Important: if your vehicle's AdBlue® tank is completely empty - which is confirmed by the alert messages and the impossibility of starting the engine - you must add at least 3.8 litres, so two 1.89 litre bottles.

 After emptying the bottle, wipe away any spillage around the tank filler using a damp cloth.

 If any additive is split or splashed, wash immediately with cold water or wipe with a damp cloth.  
If the additive has crystallised, clean it off using a sponge and hot water.

-  Refit the blue cap to the tank and turn it a 6<sup>th</sup> of a turn clockwise, to its stop.
-  Refit the black plastic blanking plug, clipping it in place.
-  Lower the boot floor and close the tailgate.

 Important: **when topping up after running out of additive**, signalled by the message "Top up emissions additive: Starting prevented", you must wait for approximately 5 minutes before switching on the ignition, **without opening the driver's door, unlocking the vehicle, placing the key of the "Keyless Entry and Starting" system inside the vehicle or inserting the electronic key in the reader.**  
Switch on the ignition, wait for 10 seconds, then start the engine.

 Never dispose of AdBlue® additive bottles in the household waste. Place them in a special container provided this purpose or take them to your dealer.

**010**

Technical data





# Petrol engines and gearboxes

Petrol engine	THP 150	THP 160	THP 165 S&S	THP 210 S&S
Gearbox	Automatic (6-speed)	Automatic (6-speed)	EAT6 automatic (6-speed)	Manual (6-speed)
Model code	5FEA	5FMA -Y -A/D	5GZT/S -T/1S -T/2S	5GMM/S
Cubic capacity (cc)	1 598	1 598	1 598	1 598
Bore x stroke (mm)	77 x 85.8	77 x 85.8	77 x 85.8	77 x 85.8
Max power*: EU standard (kW)	110	120	121	155
Max power engine speed (rpm)	6 050	6 000	6 000	6 000
Max torque: EU standard (Nm)	240	240	240	285
Max torque engine speed (rpm)	1 400	1 400	1 400	1 750
Fuel	Unleaded	Unleaded	Unleaded	Unleaded
Catalytic converter	Yes	Yes	Yes	Yes
Engine oil capacity (with filter replacement) (in litres)	4.25	4.25	4.25	4.25

\* The maximum power corresponds to the value type-approved on a test bed, under conditions defined in European legislation (Directive 1999/99/EC).

.../S: model fitted with Stop & Start.

.../1: model fitted with low rolling resistance tyres.

.../2: model fitted with very low rolling resistance tyres.

## Petrol weights and towed loads (in kg)

Petrol engine	THP 150	THP 160	THP 165 S&S	THP 210 S&S
Gearbox	Automatic (6-speed)	Automatic (6-speed)	EAT6 automatic (6-speed)	Manual (6-speed)
Model code	5FEA	5FMA -Y -A/D	5GZT/S -T/1S -T/2S	5GMM/S
- Unladen weight	1 495	1 495	1 429	1 430
- Kerb weight*	1 570	1 570	1 504	1 505
- Gross vehicle weight (GVW)	2 030	2 030	2 017	2 010
- Gross train weight (GTW) on a 12 % gradient	2 830	2 830	3 117	2 760
- Braked trailer (within GTW limit) on a 10 % or 12 % gradient	800	800	1 100	750
- Braked trailer** (with load transfer within the GTW limit)	800	800	1 400	1 050
- Unbraked trailer	745	745	750	750
- Recommended nose weight	75	75	75	75

\* The kerb weight is equal to the unladen weight + driver (75 kg).

\*\* The weight of the braked trailer can be increased, within the GTW limit, if the GVW of the towing vehicle is reduced by an equal amount; warning, towing using a lightly loaded towing vehicle may have an adverse effect on its road holding.

The GTW and towed load values indicated are valid up to a maximum altitude of 1 000 metres; the towed load mentioned must be reduced by 10 % for each additional 1 000 metres of altitude.

When towing the maximum authorised speed is reduced (comply with the legislation in force in your country).

High ambient temperatures may result in a reduction in the performance of the vehicle to protect the engine; if the ambient temperature is above 37 °C, limit the towed load.

## Petrol weights and towed loads (in kg) - Commercial versions

Petrol engine	THP 165 S&S	THP 210 S&S
Gearbox	EAT6 automatic (6-speed)	Manual (6-speed)
Model code	5GZT/S -T/1S -T/2S	5GMM/S
- Unladen weight	1 539	1 539
- Kerb weight*	1 614	1 614
- Gross vehicle weight (GVW)	2 225	2 160
- Gross train weight (GTW) on a 12% gradient	3 225	2 910
- Braked trailer (within the GTW limit) on a 10% or 12% gradient	1 000	750
- Unbraked trailer	750	750
- Recommended nose weight	75	75

\* The kerb weight is equal to the unladen weight + driver (75 kg).

The GTW and towed load values indicated are valid up to a maximum altitude of 1 000 metres; the towed load mentioned must be reduced by 10 % for each additional 1 000 metres of altitude.

When towing the maximum authorised speed is reduced (comply with the legislation in force in your country).

High ambient temperatures may result in a reduction in the performance of the vehicle to protect the engine; if the ambient temperature is above 37 °C, limit the towed load.

## Diesel engines and gearboxes

Diesel engine	BlueHDi 115 S&S		BlueHDi 120 S&S	
	Manual (6-speed)	EAT6 automatic (6-speed)	Manual (6-speed)	EAT6 automatic (6-speed)
Model code	BHXM/S -M/1S -M/2S	BHXT/S -T/1S -T/2S	BHZM/S -M/1S -M/2S	BHXT/S -T/1S -T/2S
Cubic capacity (cc)	1 560		1 560	
Bore x stroke (mm)	75 x 88.3		75 x 88.3	
Max power*: EU standard (kW)	85		88	
Max power engine speed (rpm)	3 750		3 750	
Max torque: EU standard (Nm)	300		300	
Max torque engine speed (rpm)	1 750		1 750	
Fuel	Diesel		Diesel	
Catalytic converter	Yes		Yes	
Particle filter	Yes		Yes	
Engine oil capacity (with filter replacement) (in litres)	3.75		3.75	

\* The maximum power corresponds to the value type-approved on a test bed, under conditions defined in European legislation (Directive 1999/99/EC).

.../S: model fitted with Stop & Start.

.../1: model fitted with low rolling resistance tyres.

.../2: model fitted with very low rolling resistance tyres.

# Diesel engines and gearboxes

Diesel engine	BlueHDi 135 S&S	BlueHDi 150 S&S	BlueHDi 180 S&S
Gearbox	Manual (6-speed)	Manual (6-speed)	EAT6 automatic (6-speed)
Model code	AHV AHSM/S -M/1S -M/2S	AHX AHRM/S -M/1S -M/2S	AHWT/S -T/1S -T/2S
Cubic capacity (cc)	1 997	1 997	1 997
Bore x stroke (mm)	85 x 88	85 x 88	85 x 88
Max power*: EU standard (kW)	100	110	132
Max power engine speed (rpm)	4 000	4 000	3 750
Max torque: EU standard (Nm)	320	370	400
Max torque engine speed (rpm)	2 000	2 000	2 000
Fuel	Diesel	Diesel	Diesel
Catalytic converter	Yes	Yes	Yes
Particle filter	Yes	Yes	Yes
Engine oil capacity (with filter replacement) (in litres)	6.1	6.1	5.1

\* The maximum power corresponds to the value type-approved on a test bed, under conditions defined in European legislation (Directive 1999/99/EC).

.../S: model fitted with Stop & Start.

.../1: model fitted with low rolling resistance tyres.

.../2: model fitted with very low rolling resistance tyres.

## Diesel weights and towed loads (in kg)

Diesel engine	BlueHDi 115 S&S		BlueHDi 120 S&S	
	Manual (6-speed)	EAT6 automatic (6-speed)	Manual (6-speed)	EAT6 automatic (6-speed)
Model code	BHXM/S -M/1S -M/2S	BHXT/S -T/1S -T/2S	BHZM/S -M/1S -M/2S	BHXT/S -T/1S -T/2S
- Unladen weight	1 428	1 434	1 428	1 434
- Kerb weight*	1 503	1 509	1 503	1 509
- Gross vehicle weight (GVW)	2 020	2 025	2 020	2 025
- Gross train weight (GTW) on a 12% gradient	3 120	2 775	3 120	2 775
- Braked trailer (within GTW limit) on a 10% or 12% gradient	1 100	745	1 100	745
- Braked trailer** (with load transfer with the GTW limit)	1 400	1 050	1 400	1 050
- Unbraked trailer	745	740	745	740
- Recommended nose weight	75	75	75	75

\* The kerb weight is equal to the unladen weight + driver (75 kg).

\*\* The weight of the braked trailer can be increased, within the GTW limit, if the GVW of the towing vehicle is reduced by an equal amount; warning, towing using a lightly loaded towing vehicle may have an adverse effect on its road holding.

The GTW and towed load values indicated are valid up to a maximum altitude of 1 000 metres; the towed load mentioned must be reduced by 10 % for each additional 1 000 metres of altitude.

When towing, the maximum authorised speed is reduced (comply with the legislation in force in your country).

High ambient temperatures may result in a reduction in the performance of the vehicle to protect the engine; if the ambient temperature is above 37 °C, limit the towed load.

## Diesel weights and towed loads (in kg)

Diesel engine	BlueHDi 135 S&S	BlueHDi 150 S&S	BlueHDi 180 S&S
Gearbox	Manual (6-speed)	Manual (6-speed)	EAT6 automatic (6-speed)
Model code	AHV AHS/M/S -M/1S -M/2S	AHX AHRM/S -M/1S -M/2S	AHWT/S -T/1S -T/2S
- Unladen weight	1 537	1 537	1 540
- Kerb weight*	1 612	1 612	1 615
- Gross vehicle weight (GVW)	2 130	2 130	2 125
- Gross train weight (GTW) on a 12% gradient	3 330	3 330	3 325
- Braked trailer (within GTW limit) on a 10% or 12% gradient	1 200	1 200	1 200
- Braked trailer** (with load transfer with the GTW limit)	1 500	1 500	1 500
- Unbraked trailer	750	750	750
- Recommended nose weight	75	75	75

\* The kerb weight is equal to the unladen weight + driver (75 kg).

\*\* The weight of the braked trailer can be increased, within the GTW limit, if the GVW of the towing vehicle is reduced by an equal amount; warning, towing using a lightly loaded towing vehicle may have an adverse effect on its road holding.

The GTW and towed load values indicated are valid up to a maximum altitude of 1 000 metres; the towed load mentioned must be reduced by 10 % for each additional 1 000 metres of altitude.

When towing, the maximum authorised speed is reduced (comply with the legislation in force in your country).

High ambient temperatures may result in a reduction in the performance of the vehicle to protect the engine; if the ambient temperature is above 37 °C, limit the towed load.



## Diesel weights and towed loads (in kg) - Commercial versions

Diesel engine	BlueHDi 115 S&S		BlueHDi 120 S&S	
	Manual (6-speed)	EAT6 automatic (6-speed)	Manual (6-speed)	EAT6 automatic (6-speed)
Model code	BHXM/S -M/1S -M/2S	BHXT/S - T/1S -T/2S	BHZM/S -M/1S -M/2S	BHZT/S - T/1S -T/2S
- Unladen weight	1 528	1 605	1 528	1 605
- Kerb weight*	1 603	1 680	1 603	1 680
- Gross vehicle weight (GVW)	2 150	2 225	2 150	2 225
- Gross train weight (GTW) on a 12% gradient	3 150	2 800	3 150	2 800
- Braked trailer (within the GTW limit) on a 10% or 12% gradient	1 000	575	1 000	575
- Unbraked trailer	745	575	745	575
- Recommended nose weight	75	75	75	75

\* The kerb weight is equal to the unladen weight + driver (75 kg).

The GTW and towed load values indicated are valid up to a maximum altitude of 1 000 metres; the towed load mentioned must be reduced by 10 % for each additional 1 000 metres of altitude.

When towing, the maximum authorised speed is reduced (comply with the legislation in force in your country).

High ambient temperatures may result in a reduction in the performance of the vehicle to protect the engine; if the ambient temperature is above 37 °C, limit the towed load.

## Diesel weights and towed loads (in kg) - Commercial versions

Diesel engine	BlueHDi 135 S&S	BlueHDi 150 S&S	BlueHDi 180 S&S
Gearbox	Manual (6-speed)	Manual (6-speed)	EAT6 automatic (6-speed)
Model code	AHV AHSM/S -M/1S -M/2S	AHX AHRM/S -M/1S -M/2S	AHWT/S -T/1S -T/2S
- Unladen weight	1 635	1 635	1 634
- Kerb weight*	1 710	1 710	1 709
- Gross vehicle weight (GVW)	2 255	2 255	2 255
- Gross train weight (GTW) on a 12% gradient	3 305	3 305	3 305
- Braked trailer (within GTW limit) on a 10% or 12% gradient	1 050	1 050	1 050
- Unbraked trailer	750	750	750
- Recommended nose weight	75	75	75

\* The kerb weight is equal to the unladen weight + driver (75 kg).

The GTW and towed load values indicated are valid up to a maximum altitude of 1 000 metres; the towed load mentioned must be reduced by 10 % for each additional 1 000 metres of altitude.

When towing, the maximum authorised speed is reduced (comply with the legislation in force in your country).

High ambient temperatures may result in a reduction in the performance of the vehicle to protect the engine; if the ambient temperature is above 37 °C, limit the towed load.

## Dimensions (in mm)

These dimensions have been measured on an unladen vehicle.

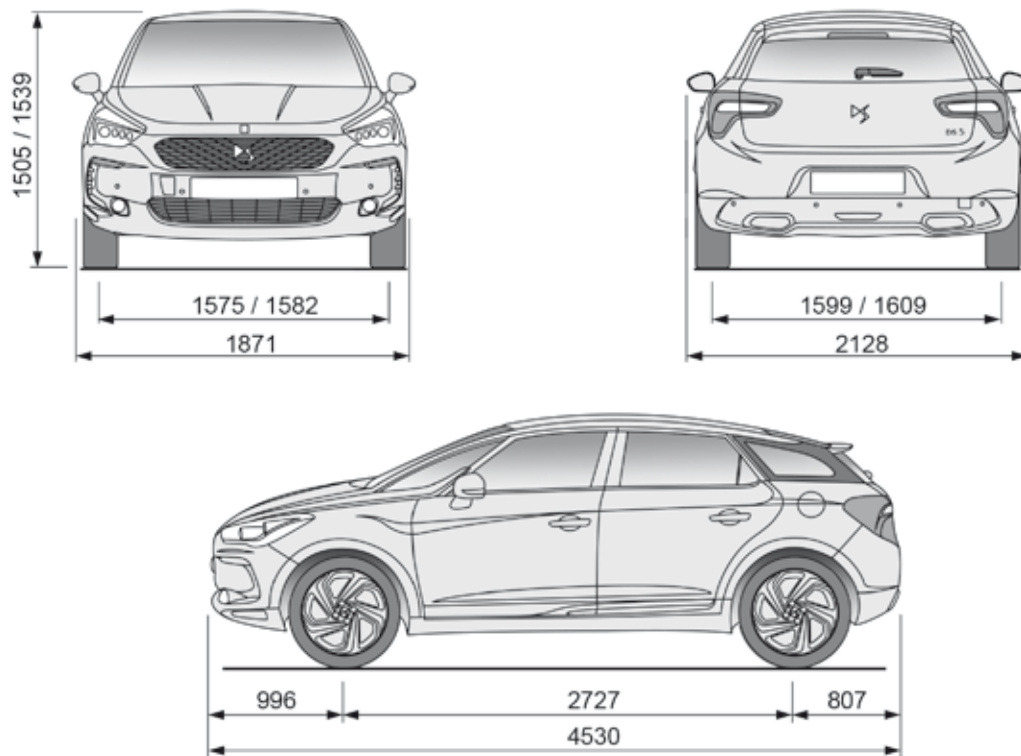

# Identification markings

Various visible markings for the identification of your vehicle.

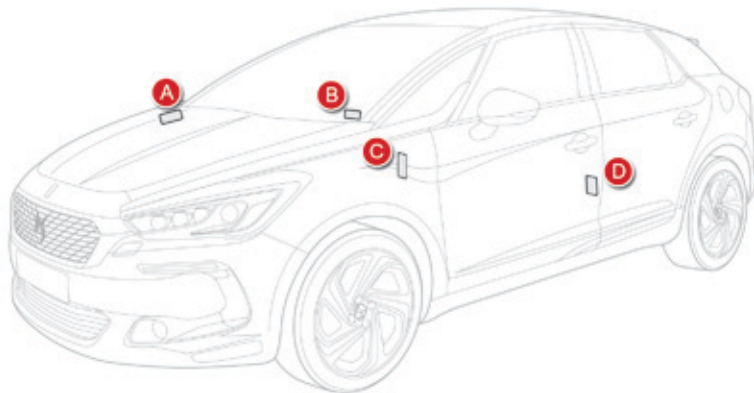

**A. Vehicle Identification Number (VIN) under the bonnet.**

This number is engraved on the bodywork near the damper support.

**B. Vehicle identification Number (VIN) on the windscreen lower cross member.**

This number is indicated on a self-adhesive label which is visible through the windscreen.

**C. Manufacturer's label.**

The VIN is indicated on a self-destroying label affixed to the door aperture, on the passenger's side.

**D. Tyre/paint label.**

This label is affixed to the centre pillar, on the driver's side.

It bears the following information:

- the tyre inflation pressures, laden and unladen,
- the tyre sizes,
- the inflation pressure of the spare wheel,
- the paint colour code.

 The tyre pressures must be checked when the tyres are cold, at least once a month.

 If the tyre pressures are too low, this increases fuel consumption.

 The rear quarter light cannot be etched as it is made of polycarbonate material.



**011**

Audio and telematics



DS AUTOMOBILES

# Emergency or assistance call



## Localised Emergency Call

SOS

In an emergency, press this button for more than 2 seconds. Flashing of the green indicator lamp and a voice message confirm that the call has been made to the "Localised Emergency Call"\* centre.

Pressing this button again immediately cancels the call.

The green indicator lamp goes off.

At any time, pressing this button for more than 8 seconds cancels the call.

The green indicator lamp remains on (without flashing) when communication is established. It goes off at the end of the call.

This call is dealt with by the "Localised Emergency Call" centre, which receives locating information from the vehicle and can send a detailed alert to the appropriate emergency services.

In countries in which a centre is not operational, or when the locating service has been expressly declined, the call is dealt with directly by the emergency services (112) without the vehicle location.



If an impact is detected by the airbag control unit, and independently of the deployment of any airbags, an emergency call is made automatically.



If you benefit from the DS Connect BOX offer with the SOS and assistance pack included, you also have available additional services in your MyCITROËN personal space, via the CITROËN Internet website in your country, accessible on [www.citroen.com](http://www.citroen.com).

\* These services are subject to conditions and availability.  
Consult a CITROËN dealer.

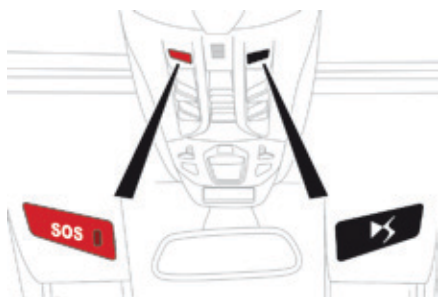



## Operation of the system



When the ignition is switched on, the green indicator lamp comes on for 3 seconds indicating that the system is operating correctly.



The orange indicator lamp flashes then goes off: the system has a fault.

The orange indicator lamp is on fixed: the back-up battery should be replaced.

In both cases, the emergency and assistance calls service may not work.

Contact a qualified repairer as soon as possible.

 The fault with the system does not prevent the vehicle being driven.

## Localised Assistance Call



Press this button for more than 2 seconds to request assistance if the vehicle breaks down.

A voice message confirms that the call has been started\*.

Pressing this button again immediately cancels the request.

The cancellation is confirmed by a voice message.

\* These services are subject to conditions and availability.  
Consult a CITROËN dealer.

 If you purchased your vehicle outside the CITROËN dealer network, we invite you to have a dealer check the configuration of these services and, if desired, modified to suit your wishes. In a multi-lingual country, configuration is possible in the official national language of your choice.

 For technical reasons, particularly to improve the quality of Telematic services to customers, the manufacturer reserves the right to carry out updates to the vehicle's on-board telematic system.

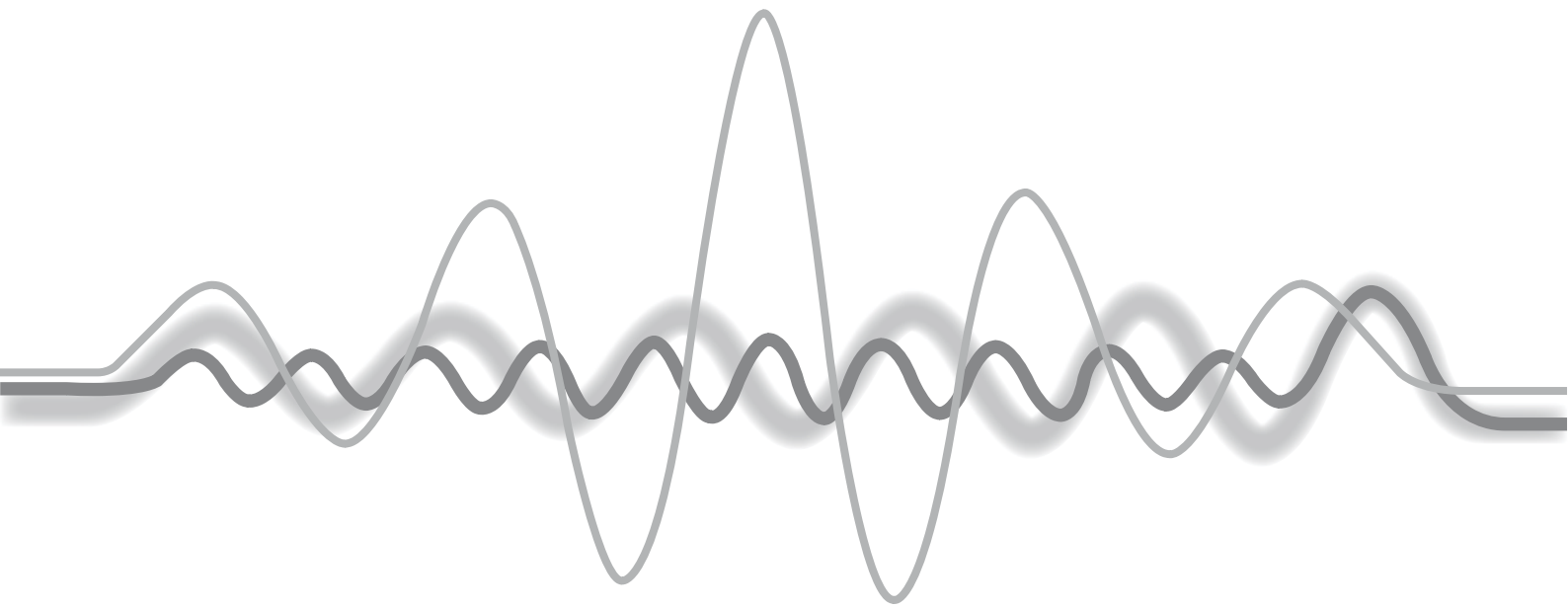

# Audio system / Bluetooth®



	Contents
First steps	282
Steering mounted controls	283
Menus	284
Audio	285
Using the telephone	292
Audio settings	300
Screen menu map(s)	301
Frequently asked questions	303

**i** The system is coded in such a way that it will only operate in your vehicle.

**!** As a safety measure, the driver must only carry out operations which require prolonged attention while the vehicle is stationary. When the engine is switched off and to prevent discharging of the battery, the audio system may switch off after a few minutes.

# First steps



On / Off.



Volume adjustment.



Audio settings:  
audio ambiances, treble, bass,  
loudness, distribution, left/right  
balance, front/rear fader, automatic  
volume.

1

Select preset radio station.  
Long press: store a station.

**LIST**

Display the list of stations received,  
CD/MP3 tracks or folders.  
Long press: managing the  
classification of MP3/WMA files /  
update the list of stations received.

**TA INFO**

TA (Traffic Announcement) function  
On / Off.  
Long press: access to type of  
information.

**MENU**

Access to main menu.

**SRC /**

Select source:  
Radio, CD, AUX, USB, Streaming.  
Accept an incoming call.

**OK**

Confirmation or display of contextual  
menu.



Manual step by step search up /  
down for radio frequencies.  
Select previous / next MP3 folder.  
Select previous / next folder / genre /  
artist / playlist in the USB device.  
Navigation in a list.



Automatic search up / down for radio  
frequencies.  
Select previous / next CD, USB,  
streaming track.  
Navigation in a list.



Abandon the current operation.  
Up one level (menu or folder).



Select screen display between modes:  
Full screen: Audio (or telephone if call  
in progress) /  
In a window: Audio (or telephone  
if call in progress) - Time or Trip  
computer.  
Long press: black screen (DARK).

**BAND**

Select AM / FM wavebands.

# Steering mounted controls

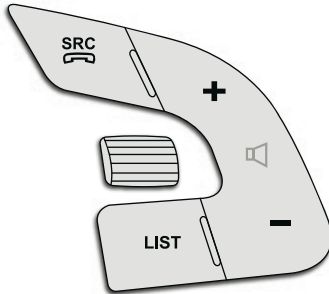

Media: change the multimedia source.  
Telephone: call.  
Call in progress: access to the telephone menu (end call, secret mode, hands-free mode).  
Telephone, press and hold: reject an incoming call, end a call; when there is no call in progress, access to the telephone menu.



Radio, rotate: automatic search for the previous / next station.  
Media, rotate: previous / next track.  
Press: confirm a selection.

**LIST**

Radio: display the list of stations.  
Media: display the list of tracks.  
Radio, press and hold: update the list of stations received.



Increase volume.



Decrease volume.

# Menus

## Screen C



**"Multimedia"**: Media parameters, Radio parameters.



**"Telephone"**: Call, Directory management, Telephone management, Hang up.



**"Bluetooth connection"**: Connections management, Search for a device.



**"Personalisation-configuration"**: Define the vehicle parameters, Choice of language, Display configuration, Choice of units, Date and time adjustment.





For a detailed global view of the menus available, refer to the "Screen menu map" section.





# Audio

## Selecting a station

 The exterior environment (hills, buildings, tunnel, car park, below ground...) may prevent reception, even in RDS station tracking mode. This phenomenon is normal in the propagation of radio waves and is in no way indicative of a fault with the audio system.

 Press **SOURCE** or **SRC** several times in succession and select radio.

 Press **BAND** to select a waveband.

 Press **LIST** to display the list of stations received in alphabetical order.

 Select the desired radio station and confirm by pressing **OK**.

 A press changes to the next or previous letter (e.g. A, B, D, F, G, J, K, ...).

### LIST

A long press on **LIST** builds or updates the list of stations; audio reception is cut momentarily.

## RDS

 RDS, if displayed, enables you to continue listening to the same station by automatic retuning to alternative frequencies. However, in certain conditions, coverage of an RDS station may not be assured throughout the country as radio stations do not cover 100 % of the territory. This explains the loss of reception of the station during a journey.

**OK**

When the radio is displayed on the screen, press **OK** to display the contextual menu.

**OK**

Select "**RDS**" and confirm to save. "**RDS**" is displayed in the screen.

## Receiving TA messages

 The TA (Traffic Announcement) function gives priority to TA alert messages. To operate, this function needs good reception of a radio station transmitting this type of message. When a traffic report is transmitted, the current audio source (Radio, CD, USB, ...) is interrupted automatically to play the TA message. Normal playback of the audio source resumes at the end of the transmission of the message.

**TA INFO**

Press **TA INFO** to activate or deactivate the reception of traffic messages.

## Receiving INFO messages

 The INFO function gives priority to TA alert messages. To be active, this function needs good reception of a radio station that transmits this type of message. When a message is transmitted, the current audio source (Radio, CD, USB, ...) is interrupted automatically to receive the INFO message. Normal play resumes at the end of the message transmission.

**TA INFO**

Make a long press on **TA INFO** to display the list of categories.



Select or deselect categories to activate or deactivate the reception of the corresponding messages.



## Display RADIO TEXT

 Radio text is information transmitted by the radio station related to the current programme or song.

### Screen C

**OK**

With the radio displayed on the screen, press **OK** to display the contextual menu.



Select "**RadioText (TXT) display**" and confirm **OK** to save.

## Audio CD

### Playing a CD

 Insert 12 cm diameter circular compact discs only.  
Some anti-pirating systems, on original discs or CDs copied using a personal recorder, may cause faults which are no reflection on the quality of the original player.  
Without pressing the **EJECT** button, insert a CD in the player, play begins automatically.

**SRC** / 

To play a disc which has already been inserted, press the **SOURCE** or **SRC** button several times in succession and select "**CD**".



Press one of the buttons to select a track on the CD.

**LIST**

Press **LIST** to display the list of tracks on the CD.



Press and hold one of the buttons for fast forward or backward.

# CD, USB

## Information and advice

The audio system will only play files with extension ".mp3" or ".wma" and a compression rate that is constant or variable between 32 Kbps and 320 Kbps.

It is advisable to restrict file names to 20 characters without using special characters (e.g. " ? ; ù) to avoid any playing or displaying problems.

The playlists accepted are types .m3u and .pls. The number of files is limited to 5 000 in 500 directories on a maximum of 8 levels.



On a single disc, the CD player can read up to 255 MP3 files spread over 8 directory levels. However, it is recommended that this be kept to 2 levels so as to limit the time taken to access and play the CD. During play, the folder structure is not observed.

In order to be able to play a recorded CDR or CDRW, when recording it is preferable to select standards ISO 9660 level 1.2 or Joliet.

If the disc is recorded in another format, it may not be played correctly.

It is recommended that the same recording standard is always used for an individual disc, with as low a speed as possible (4x maximum) for optimum sound quality.

In the particular case of a multi-session CD, the Joliet standard is recommended.

Use only USB memory sticks formatted FAT32 (File Allocation Table).



Do not connect a hard disk or USB device other than audio players to the USB port. This may cause damage to your installation.

## CD, USB

### Playing a compilation

 Insert an MP3 compilation in the CD player or connect a memory stick to the USB port, directly or via an extension lead.

The system creates playlists (temporary memory) the creation time for which can take from a few seconds to several minutes.

The playlists are updated every time the ignition is switched off or a USB memory stick is connected.

Play starts automatically after a period which depends on the capacity of the USB memory stick.

At a first connection, the order suggested is by folder. When connecting again, the order previously chosen is retained.



To play a disc or memory stick which has already been inserted, press **SOURCE** or **SRC** several times in succession and select "CD" or "USB".



Select a track or a folder.



Press one of the buttons to select the next or previous track.



Up a level in the menu.



Press one of the buttons to select the next or previous folder in the order chosen.



Skip a track.



Press and hold one of the buttons for fast forwards or backwards.



Press **LIST** to display the menu of folders in the compilation.



Select a line in the list.

## USB memory stick - File sorting

### LIST

Make a long press on **LIST** or press **MENU**, select "**Multimedia**", then "**Media parameters**" and finally "**Choice of track listing**" to display the different types of sorting.



Having selected the desired sorting ("**By folders**", "**By artists**", "**By genres**", "**By playlists**") press **OK**. Then confirm **OK** to save the modifications.

### OK

- **By folders**: all folders containing audio files recognised on the peripheral device, in alphabetical order without following the folder structure.
- **By artists**: all of the artist names defined in the ID3 Tags, in alphabetical order.
- **By genres**: all of the genres defined in the ID3 Tags.
- **By playlists**: if playlists have been saved.

## USB players

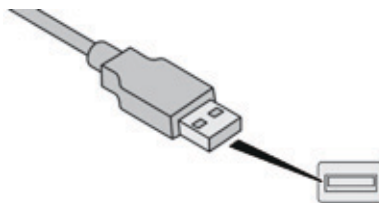

The audio files on a Mass Storage portable player\* can be heard through the vehicle's speakers by connecting it to the USB port (cable not supplied).



Management of the device is via the audio system controls.

If the portable player is not recognised by the USB port, connect it to the auxiliary Jack socket.

The Apple® player must be updated regularly for the best connection.

The playlists are those defined in the Apple® player.

The Apple® player must be generation 5 or later.

\* Check your player's manual.

## Auxiliary socket (AUX)



The auxiliary Jack socket permits the connection of a portable non-mass storage device or an Apple® player if not recognised by the USB port.

 Do not connect a device to the USB port and to the auxiliary Jack socket at the same time.

Connect the portable device to the auxiliary Jack socket using a suitable cable (not supplied).



Press the **SOURCE** or **SRC** button several times in succession and select "**AUX**".

First adjust the volume on your portable device.



Then adjust the volume of the audio system.

The display and management of controls is on the portable device.

## Streaming - Playing audio files via Bluetooth

### Depending on the compatibility of the phone

Streaming allows music files on a telephone to be heard via the vehicle's speakers. The telephone must support the appropriate Bluetooth profiles (Profiles A2DP / AVRCP).



Pair/connect the telephone: see the "USING THE TELEPHONE" section.



Activate the streaming source by pressing **SOURCE** or **SRC**. Control of playback is via the audio system. The contextual information can be displayed in the screen.



In certain cases, playing of the audio files must be initiated from the telephone.

The audio quality depends on the quality of the transmission from the telephone.

## Play mode



The play modes available are:

- Normal: the tracks are played in order, depending on the classification of the selected files.
- Random: the tracks in an album or folder are played in a random order.
- Random all: all of the tracks saved in the media are played in random order.
- Repeat: the tracks played are only those from the current album or folder.

**MENU**

Press **OK** for access to the contextual menu.

or

Press **MENU**.



Select "**Multimedia**" and confirm.



Select "**Media parameters**" and confirm.



Select "**Read mode**" and confirm.



Select the desired play mode and confirm **OK** to save the modifications.



# Using the telephone

## Pairing a telephone

### First connection

The services offered depend on the network, the SIM card and the compatibility of the Bluetooth telephone used.

Consult your telephone's manual and your operator to find out which services are available to you.



As a safety measure and because they require prolonged attention on the part of the driver, the operations for pairing of the Bluetooth mobile telephone with the Bluetooth hands-free system of your audio system must be carried out with the **vehicle stationary** and the ignition on.

Visit [www.citroen.co.uk](http://www.citroen.co.uk) for more information (compatibility, additional help, ...).

Activate the telephone's Bluetooth function and ensure that it is "visible to all" (refer to the telephone user guide).

**MENU**

Press **MENU**.



## Streaming - Playing audio files via Bluetooth

Pair/connect the telephone then play the files: see the "Pairing" section.

 Select "**Bluetooth connection**" and confirm.

**OK**

 Select "**Search for a device**".

**OK**

A window is displayed "**Search in progress...**".

 Select the telephone to be connected from the list. Only one telephone can be connected at a time.

**OK**

In some cases, the reference number of the telephone or the Bluetooth address may appear instead of the name of the telephone.

 A virtual keypad is displayed on the screen: enter a code with at least 4 digits and conform with **OK**.

**OK**

A message is displayed on the screen of the telephone: enter the same code and confirm.

If pairing fails, try again; the number of attempts is not limited.

Accept the connection to the telephone.

A message appears in the screen to confirm successful connection.

 Pairing can also be initiated from the telephone by searching for detected Bluetooth devices.

The directory and the calls list can be accessed after the synchronisation period (if the telephone is compatible). Automatic connection must be configured in the telephone to allow the connection each time the vehicle is started.

## Managing connections



The telephone connection automatically includes hands free operation and audio streaming.

The ability of the system to connect to just one profile depends on the telephone. Both profiles may connect by default.

**MENU**

Press **MENU**.



Select "**Bluetooth connection**" and confirm.

**OK**



Select "**Connections management**" and confirm. The list of paired telephones is displayed.

**OK**



Indicates that a device is connected.



Indicates connection of the audio streaming profile.



Indicates connection of the hands-free profile.



Select a telephone and confirm.

**OK**



Then select and confirm:

- "**Connect telephone**" / "**Disconnect telephone**": to connect / disconnect the telephone or the hands-free connection only.
- "**Connect media player**" / "**Disconnect media player**": to connect / disconnect only streaming.
- "**Connect telephone + media player**" / "**Disconnect telephone + media player**": to connect / disconnect the telephone (hands-free and streaming).
- "**Delete connection**": to delete the pairing.

**OK**





## Making a call - Dialling

-  To display the **"TELEPHONE"** menu:
- Make along press on **SOURCE** or **SRC**.
  - Or, press **OK** to display the contextual menu. Select **"Call"** and confirm.
  - Or, press **MENU**, select **"Telephone"** and confirm. Select **"Call"** and confirm.

 Select numbers one at a time using the **◀** and **▶** buttons and confirm.

**OK**

**OK**

Correction allows numbers to be deleted one at a time.

 Select **"Dial"** to enter a number and confirm.

 Select **OK** and confirm to start the call.

**OK**

## Making a call - Recently called numbers\*

SRC / 

To display the "TELEPHONE" menu:

- Make a long press on **SRC/TEL**.
- Or, press the dial to display the contextual menu. Select "**Call**" and confirm.
- Or, press **MENU**, select "**Telephone**" and confirm. Select "**Call**" and confirm.



Select the number and confirm to start the call.

OK



The calls list includes calls sent and received in the vehicle using the connected telephone.



It is possible to make a call directly from the telephone; park the vehicle first as a safety measure.



Select "**Calls list**" and confirm.

OK

## Making a call - From the directory of contacts

SRC / 

To display the "TELEPHONE" menu:

- Make a long press on **SRC/TEL**.
- Or, press the dial to display the contextual menu. Select "**Call**" and confirm.
- Or, press **MENU**, select "**Telephone**" and confirm. Select "**Call**" and confirm.





Select "**Directory**" and confirm.



OK

\* Depending on the compatibility of the telephone.





Select a contact then confirm.

  Home

  Business

 Mobile  
(depending on the information available in the contact records of the telephone connected).

Select the number and confirm.

 

## Receiving a call

An incoming call is announced by a ring and a superimposed display in the multifunction screen.

 "YES" to accept the call is selected by default.  
Press **OK** to accept the call.  
Select "**NO**" and confirm to reject the call.  
or  
Press one of these buttons to accept the call.



 A long press on **ESC** or on **TEL**, **SOURCE** or **SRC** also rejects an incoming call.







## Managing calls

 During a call, press **OK** to display the contextual menu.

### Hang up

 In the contextual menu, select "**Hang up**" to end the call.



 A long press on one of these buttons also ends the call.



## Secret - Mute

(so that the caller cannot hear)



OK



In the contextual menu:

- select "**Micro OFF**" to switch off the microphone.
- deselect "**Micro OFF**" to switch the microphone on.

OK

## Combined mode

(to leave the vehicle without ending the call)



In the contextual menu:

- select "**Telephone mode**" to transfer the call to the telephone.
- deselect "**Telephone mode**" to transfer the call to the vehicle.

OK

In certain cases, the combined mode has to be activated from the telephone.

If the contact has been cut off, when you reconnect on returning to the vehicle, the Bluetooth connection will be restored automatically (depending on the compatibility of the telephone).

## Interactive voice response



From the contextual menu, select "**DTMF tones**" and confirm to use the digital keypad to navigate in the interactive voice response menu.

OK

## Consultation call



From the contextual menu, select "**Switch**" and conform to return to a call left on hold.

OK

## Directory



The system accesses the telephone's contacts directory, depending on its compatibility, and while it is connected by Bluetooth.



With certain telephones connected by Bluetooth you can send a contact to the directory of the audio system. Contacts imported in this way are saved in a permanent directory visible to all, whatever the telephone connected.

The menu for the directory is not accessible if it is empty.



Select "**Directory**" to see the list of contacts.



To modify the contacts saved in the system, press **MENU** then select "**Telephone**" and confirm. Select "**Directory management**" and confirm.

You can:

- "**Consult an entry**",
- "**Delete an entry**",
- "**Delete all entries**".

Make a long press on **SOURCE** or **SRC** for access to the directory or press **OK**, and select "**Call**" and confirm.



# Audio settings

## Screen C

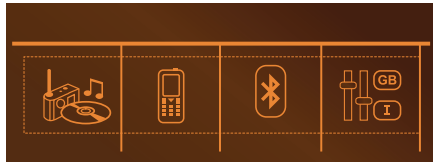

Press  to display the audio settings menu.

The settings available are:

- Ambience,
- Bass,
- Treble,
- Loudness,
- Distribution: Personalised or Driver,
- Left / right balance,
- Fader (front / rear balance),
- Auto. volume.



Select and confirm "**Other settings...**" to display the next setting in the list.

OK



The distribution (or spatialisation using the Arkamys® system), is an audio process which allows the sound quality to be improved according to the setting chosen, corresponding to the position of the listeners in the vehicle.



The Ambience, Treble and Bass audio settings are different and independent for each sound source.



On-board audio: Arkamys® Sound Staging optimises sound distribution in the the passenger compartment.

# Screen menu map(s)

## Screen C

### Main function

#### 1 Option A

##### 2 Option A1

##### 3 Option A11

#### 1 Option B...

### MEDIA

#### 1 Media parameters

##### 2 Choice of playback mode

##### 3 Normal

##### 3 Random

##### 3 Random all

##### 3 Repeat

##### 2 Choice of track listing

##### 3 By folders

##### 3 By artists

##### 3 By genres

##### 3 By playlists

#### 1 Radio parameters

### TELEPHONE

#### 1 Call

##### 2 Dial

##### 2 Directory

##### 2 Calls list

##### 2 Voice mail box

#### 1 Directory management

##### 2 Consult an entry

##### 2 Delete an entry

##### 2 Delete all entries

#### 1 Telephone management

##### 2 Telephone status

#### 1 Hang up

### BLUETOOTH CONNECTION

#### 1 Connections management

#### 1 Search for a device

## **PERSONALISATION- CONFIGURATION\***

**1** Define the vehicle parameters

**1** Choice of language

**1** Display configuration

**2** Choice of units

**2** Date and time adjustment

**2** Display parameters

**2** Brightness

\* The settings vary according to the trim level of the model.



## Frequently asked questions

The following tables contain answers to the most frequently asked questions.

QUESTION	ANSWER	SOLUTION
There is a difference in sound quality between the different audio sources (radio, CD...).	For optimum sound quality, the audio settings (Volume, Bass, Treble, Ambience, Loudness) can be adapted to the different sound sources, which may result in audible differences when changing source (radio, CD...).	Check that the audio settings (Volume, Bass, Treble, Ambience, Loudness) are adapted to the sources listened to. It is advisable to set the AUDIO functions (Bass, Treble, Front-Rear Fader, Left-Right Balance) to the middle position, select the musical ambience "None" and set the loudness correction to the "Active" position in CD mode or to the "Inactive" position in radio mode.
If the bass and treble settings are modified, the ambience selected is cancelled.	The selection of an ambience imposes specific bass and treble settings.	To obtain the desired sound quality, modify the treble and bass settings or select a pre-defined ambience setting.
If the ambience setting is changed, the previous settings for treble and bass are cancelled.		
If the "Driver" / "All passengers" distribution is modified, the balance settings are cancelled.	Choosing a distribution setting imposes a specific balance setting. Modifying one without the other is not possible.	Modify the balance setting or the distribution setting to obtain the desired sound quality.
When changing the balance setting, the "Driver" / "All passengers" distribution is cancelled.		

QUESTION	ANSWER	SOLUTION
<p>The quality of reception of the radio station listened to gradually deteriorates or the stored stations do not function (no sound, 87.5 MHz is displayed...).</p>	<p>The vehicle is too far from the transmitter used by the station listened to or there is no transmitter in the geographical area through which the vehicle is travelling.</p>	<p>Activate the RDS function to enable the system to check whether there is a more powerful transmitter in the geographical area.</p>
	<p>The environment (hills, buildings, tunnels, basement car parks...) block reception, including in RDS mode.</p>	<p>This phenomenon is normal and does not indicate a failure of the audio equipment.</p>
	<p>The aerial is absent or has been damaged (for example when going through an automatic car wash or in an underground car park).</p>	<p>Have the aerial checked by a CITROËN dealer.</p>
<p>Sound cut-outs of 1 to 2 seconds in radio mode.</p>	<p>During this brief sound cut-out, the RDS searches for another frequency giving better reception of the station.</p>	<p>Deactivate the RDS function if the phenomenon is too frequent and always on the same route.</p>
<p>The traffic announcement (TA) is displayed. I do not receive any traffic information.</p>	<p>The radio station does not broadcast traffic information.</p>	<p>Tune to a radio station which broadcasts traffic information.</p>
<p>The stored stations are not found (no sound, 87.5 MHz is displayed...).</p>	<p>An incorrect waveband is selected.</p>	<p>Press the BAND button to return to the waveband on which the stations are stored.</p>

QUESTION	ANSWER	SOLUTION
The CD is ejected automatically or is not played by the player.	<p>The CD is inserted upside down, is unplayable, does not contain any audio data or contains an audio format which the player cannot play.</p> <p>The CD is protected by an anti-pirating protection system which is not recognised by the audio equipment.</p>	<ul style="list-style-type: none"> <li>- Check that the CD is inserted in the player the right way up.</li> <li>- Check the condition of the CD: the CD cannot be played if it is too damaged.</li> <li>- Check the content in the case of a recorded CD: consult the advice in the "Audio" section.</li> <li>- The audio equipment's CD player does not play DVDs.</li> <li>- Due to their quality level, certain writeable CDs will not be played by the audio system.</li> </ul>
The CD player sound is poor.	The CD used is scratched or of poor quality.	Insert good quality CDs and store them in suitable conditions.
	The audio settings (bass, treble, ambience) are unsuitable.	Set the treble or bass level to 0, without selecting an ambience.
I am unable to connect my Bluetooth telephone.	It is possible that Bluetooth is switched off on the telephone or that the telephone has not been made not visible.	<ul style="list-style-type: none"> <li>- Check that your telephone has Bluetooth switched on.</li> <li>- Check in the telephone's settings that it is "Visible to all".</li> </ul>
	The Bluetooth telephone is not compatible with the system.	You can check the compatibility of your telephone on <a href="http://www.citroen.co.uk">www.citroen.co.uk</a> (services).
The Bluetooth connection is cut.	The battery of the peripheral may not be sufficiently charged.	Recharge the battery of the peripheral device.

QUESTION	ANSWER	SOLUTION
The message "USB peripheral error" or "Peripheral not recognised" is displayed in the screen.	The USB memory stick is not recognised. The memory stick may be corrupt.	Reformat the memory stick (FAT32).
A telephone connects automatically, disconnecting another telephone.	Automatic connection overrides manual connection.	Modify the telephone settings to remove automatic connection.
The Apple® player is not recognised when connecting to the USB port.	The Apple® player is of a generation that is not compatible with a USB connection.	Connect the Apple® player to the AUX Jack socket using a suitable cable (not supplied).
The hard disk or device is not recognised when connecting to the USB port.	Some hard disks and devices need a power supply greater than is provided by the audio system.	Connect the device to the 230 V socket, the 12 V socket or an external power supply. <b>Caution:</b> ensure that the device does not transmit a voltage greater than 5 V (risk of destruction of the system).
When streaming, the sound cuts momentarily.	Some models of telephone prioritise connection with the "hands-free" profile.	Delete the "hands-free" connection profile to improve streaming.

QUESTION	ANSWER	SOLUTION
In "Random all" play, not all of the tracks are played.	In "Random all" play, the system can only take into account up to 999 tracks.	
With the engine off, the audio system switches off after a few minutes of use.	When the engine is switched off, the audio system operating time depends on the state of charge of the battery. The switch-off is normal: energy economy mode is activated automatically to preserve the state of charge of the vehicle's battery. (See the "Energy Economy Mode" section).	Start the vehicle's engine to increase the battery charge.
The message "the audio system is overheated" appears on the display.	In order to protect the installation if the surrounding temperature is too high, the audio system switches to an automatic thermal protection mode leading to a reduction of the volume or stopping of the playing of the CD.	Switch the audio system off for a few minutes to allow the system to cool.

# Alphabetical index



## A

Accessories .....	234
Accessory position .....	101
Additive, AdBlue .....	29, 253-261
Additive, Diesel .....	250, 251
Adjusting headlamps .....	150
Adjusting head restraints .....	72, 75
Adjusting seats .....	72, 73
Adjusting the date .....	39, 42
Adjusting the height and reach of the steering wheel .....	81
Adjusting the seat belt height .....	187
Adjusting the time .....	38, 39, 42
Advice on care and maintenance .....	233
Advice on driving .....	98, 99
Airbags .....	31, 189
Airbags, curtain .....	191, 192
Airbags, front .....	189, 192
Airbags, lateral .....	191, 192
Air conditioning, automatic .....	90, 91
Air vents .....	89
Alarm .....	63
Anti-lock braking system (ABS) .....	182
Anti-pinch .....	68
Anti-theft .....	101
Armrest, front .....	82, 85
Armrest, rear .....	82, 86
Ashtray .....	82
Assistance call .....	181, 278
Assistance, emergency braking .....	182
Audible warning .....	181
Audio streaming (Bluetooth) .....	291, 293
Audio system .....	39, 281
Automatic headlamps .....	20, 147

## B

Battery .....	223-227, 251
Battery, charging .....	225
Battery, remote control .....	59, 60
Black panel .....	38
Blind spot sensors .....	123
BlueHDi .....	246, 253-261
Bluetooth (hands-free) .....	292
Boot .....	62
Boot (opening) .....	53
Brake discs .....	252
Brake lamps .....	216
Brake warning lamp .....	27
Braking assistance system .....	182
Braking, dynamic emergency .....	103, 107
Bulbs (changing) .....	211-218

## C

Capacity, fuel tank .....	239
Cap, fuel filler .....	239
CD .....	287
CD, MP3 .....	288, 289
Central locking .....	53, 55
Changing a bulb .....	211-218
Changing a fuse .....	219-222
Changing a wheel .....	202-209
Changing a wiper blade .....	156, 228
Changing the remote control battery .....	59
Checking the engine oil level .....	36, 247
Checking the levels .....	247-250
Checking tyre pressures (using the kit) .....	201
Checks .....	244, 245, 251, 252
Checks, routine .....	251, 252

Child lock .....	169, 176
Children .....	160-176, 188, 190
Child seats .....	162-188
Child seats, conventional .....	168, 169
Child seats, ISOFIX .....	170-173
Cigarette lighter .....	83
CITROËN Localised Emergency Call .....	278
Cleaning (advice) .....	233
Clock .....	38
Closing the boot .....	62
Closing the doors .....	53, 55
Configuration, vehicle .....	39, 45
Control, emergency boot release .....	62
Control, emergency door .....	57
Control, heated seats .....	76
Control stalk, lighting .....	142, 148
Control stalk, wipers .....	153-155
Courtesy lamps .....	157
Cruise control .....	128, 133
Cup holder .....	82

## D

Date (setting) .....	39, 42
Daytime running lamps .....	145, 211, 212
Deactivating ESC .....	184
Deactivating the passenger airbag .....	190
Deadlocking .....	56
Demisting, defrosting .....	95
Demisting, defrosting the mirrors .....	80, 95





Diesel ..... 21, 241  
 Dimensions ..... 273  
 Dipstick ..... 36, 247  
 Direction indicators ..... 148, 180, 211, 214-216  
 Display screen, instrument panel ..... 46, 115  
 Display screen, multifunction  
 (with audio system) ..... 39  
 Driving economically ..... 14  
 Driving positions (storing) ..... 74  
 Dynamic stability control (DSC) ..... 27, 182, 184

**E**  
 Eco-driving ..... 14  
 Economy mode ..... 227  
 Electronic brake force  
 distribution (EBFD) ..... 182  
 Emergency braking assistance (EBA) ..... 182  
 Emergency call ..... 181, 278  
 Emergency warning lamps ..... 88, 180  
 Emissions control system, SCR ..... 30, 253  
 Energy economy mode ..... 227  
 Engine compartment ..... 244, 245  
 Engine, Diesel ..... 241, 245, 246, 267  
 Engine, petrol ..... 240, 244, 264  
 Environment ..... 14, 59, 90, 95, 225, 261

**F**  
 Filling the fuel tank ..... 239-242  
 Filter, air ..... 251  
 Filter, oil ..... 251  
 Filter, particle ..... 250, 251  
 Filter, passenger compartment ..... 251  
 Fitting a wheel ..... 208  
 Fitting roof bars ..... 232  
 Fittings, boot ..... 87  
 Fittings, interior ..... 82  
 Fittings, rear ..... 86  
 Flap, fuel filler ..... 239, 242  
 Flashing indicators ..... 148, 180  
 Foglamps, front ..... 144, 152, 211, 214  
 Foglamps, rear ..... 144, 216, 217  
 Folding/unfolding  
 the door mirrors ..... 80  
 Fuel ..... 240, 241  
 Fuel consumption ..... 14  
 Fuel tank ..... 242  
 Fusebox, dashboard ..... 221  
 Fusebox, engine compartment ..... 222  
 Fuses ..... 219

**G**  
 Gauge, fuel ..... 18, 239  
 Gearbox, automatic ..... 14, 109, 111, 118, 223, 252  
 Gearbox, manual ..... 14, 109, 110, 118, 252  
 Gear lever, automatic gearbox ..... 111  
 Gear lever, manual gearbox ..... 110

Gear shift indicator ..... 115  
 Guide-me-home ..... 146, 148

**H**  
 Hazard warning lamps ..... 88  
 Hazard warning lamps, automatic  
 operation ..... 180  
 Headlamp adjustment ..... 150  
 Headlamps, automatic illumination ..... 143, 146  
 Headlamps, dipped beam ..... 20, 142, 211  
 Headlamps, directional ..... 151, 211  
 Headlamps, halogen ..... 211  
 Headlamps, main beam ..... 20, 142, 211, 213  
 Headlamps, Xenon ..... 211  
 Headlamp wash ..... 154, 249  
 Head restraints, front ..... 72, 75  
 Head restraints, rear ..... 79  
 Head-up display ..... 126, 130, 133  
 Heating ..... 91  
 Hill start assist ..... 109

**I**  
 Identification, vehicle ..... 274  
 Ignition ..... 101

Ignition on.....	101
Immobiliser, electronic.....	60, 101
Indicator, coolant temperature.....	32
Indicator, engine oil level.....	36
Indicator lamps, operation.....	19-31
Indicators, direction.....	180
Inflating tyres.....	14, 275
Inflating tyres and accessories (using the kit).....	201
Input, auxiliary.....	291
Instrument panels.....	18
Intelligent Traction Control.....	183
ISOFIX.....	170-174
Isofix mountings.....	170

## J

Jack.....	202, 203
Jump starting.....	224

## K

Key.....	52-60, 101
Key, electronic.....	52-55, 57
Keyless Entry and Starting.....	54, 60

Kit, hands-free.....	292
Kit, temporary puncture repair.....	196

## L

Labels, identification.....	274
Lamps, cleaning.....	233
Lamps, parking.....	148
Lane Departure Warning System (LDWS) ...	122
Leather (care).....	233
LEDs - light-emitting diodes.....	145, 216
Level, AdBlue® additive.....	253
Level, brake fluid.....	248
Level, Diesel additive.....	250, 251
Level, engine coolant.....	32, 249
Level, engine oil.....	36, 247
Level, headlamp wash.....	249
Level, power steering fluid.....	248
Levels and checks.....	244, 245, 247-250
Level, screenwash fluid.....	249
Light-emitting diodes - LEDs.....	145, 216
Lighting.....	158
Lighting, dashboard.....	37
Lighting dimmer.....	37
Lighting, directional.....	151, 152
Lighting, guide-me home.....	146, 148
Lighting, interior.....	157, 158
Lighting, mood.....	158
Lighting, welcome.....	149
Loading.....	14, 232
Load reduction mode.....	227
Localised Assistance Call.....	278
Locating your vehicle.....	55

Locking from the inside.....	61
Long objects, transporting.....	86
Low fuel level.....	28, 239
Lumbar.....	76

## M

Maintenance, routine.....	14, 233
Map reading lamps.....	157
Markings, identification.....	274
Massage function.....	76
Mat.....	84
Memorising a speed.....	128
Menu, audio system.....	284
Mirror, rear view.....	81
Mirrors, door.....	80, 123
Misfuel prevention.....	242
Mountings, Isofix.....	170
MP3 CD.....	288, 289

## N

Number plate lamps.....	218
-------------------------	-----

## O

Oil change .....	247
Oil consumption .....	247
Oil, engine .....	36, 247
Opening the boot .....	52-54, 62
Opening the doors .....	52, 54

## P

Pads, brake .....	252
Paint colour code .....	274
Parking brake, electric .....	26, 103, 107, 252
Parking sensors, front .....	137
Parking sensors, rear .....	136
Petrol .....	240
Plates, identification .....	274
Player, MP3 CD .....	288, 289
Port, USB .....	85, 290
Pressures, tyres .....	197, 274
Pre-tensioning seat belts .....	188
Priming the fuel system .....	246
Protecting children .....	160-176, 188, 190
Puncture .....	196

## R

Radio .....	285
Range, AdBlue .....	254, 255

Rear screen, demisting .....	80, 95
Recharging the battery .....	225
Reduction of electrical load .....	227
Regeneration of the particle filter .....	251
Reinitialising the remote control .....	59
Remote control .....	52-55, 60
Removing a wheel .....	206
Removing the mat .....	84
Replacing bulbs .....	211-218
Replacing fuses .....	219-222
Replacing the air filter .....	251
Replacing the oil filter .....	251
Replacing the passenger compartment filter .....	251
Resetting the service indicator .....	35
Resetting the trip recorder .....	37, 46, 47
Reversing camera .....	138
Reversing lamp .....	216
Roof bars .....	232
Roof, Cockpit glass .....	68
Running out of fuel (Diesel) .....	246

## S

Safety, children .....	160-176, 188, 190
Saturation of the particle filter (Diesel) .....	251
Screen, instrument panel .....	18, 46
Screen menu map .....	301, 302
Screen, monochrome .....	39, 284, 301
Screenwash reservoir .....	249

Screenwash, front .....	154
Screenwash, rear .....	154
SCR (Selective Catalytic Reduction) .....	253
Seat belts .....	168, 186-188
Seats, front .....	72-74
Seats, heated .....	76
Seats, rear .....	77, 79
Serial number, vehicle .....	274
Service indicator .....	33
Servicing .....	14
Settings, equipment .....	39, 45
Sidelamps .....	142, 145, 148, 211-213, 216
Side repeater .....	215
Ski flap .....	86
Snow chains .....	210
Socket, 12 V accessory .....	82, 83
Sockets, audio .....	85, 290, 291
Speed limiter .....	128, 130
Spotlamps, side .....	149, 215
Starting the engine .....	100, 102, 111
Starting using another battery .....	224
Steering mounted controls, audio .....	283
Steering wheel, adjustment .....	81
Stickers, expressive .....	233
Stop & Start .....	22, 48, 92, 95, 118, 223, 226, 239, 243, 251
Storage .....	82, 85-87
Storing driving positions .....	74
Stowing rings .....	87
Switching off the engine .....	100, 102, 111
Synchronising the remote control .....	59

## T

Table of weights .....	265, 269
Tables of engines .....	264, 267
Tables of fuses .....	219
Tank, AdBlue® additive .....	253, 258
Tank, fuel .....	239, 242
Technical data .....	264-276
Temperature, coolant .....	32
Third brake lamp .....	218
Three flashes (direction indicators) .....	180
Time (setting) .....	38, 39, 42
Tools .....	202, 203
Topping-up the AdBlue® additive .....	258
Total distance recorder .....	37
Touch screen .....	38, 43, 45, 47
Towbar .....	231
Towed loads .....	265, 269
Towing another vehicle .....	230
Traction control (ASR) .....	27, 182
Traffic information (TA) .....	286
Trailer .....	99, 231
Trajectory control systems .....	182
Triangle, warning .....	88
Trip computer .....	46-48
Trip distance recorder .....	37
Tyres .....	14, 276
Tyre under-inflation detection .....	116

## U

Under-inflation (detection) .....	116
Unlocking .....	52, 54
Unlocking from the inside .....	61

Unlocking the boot .....	53
Unlocking the doors .....	61
UREA .....	253, 254
USB player .....	85

## V

Ventilation .....	89, 90
Visibility .....	95

## W

Warning and indicator lamps .....	19-31
Warning lamp, braking system .....	27
Warning lamp, Diesel engine pre-heater .....	21
Warning lamps .....	21, 24, 26
Warning lamp, SCR emissions control system .....	30
Warning lamp, Service .....	25
Washing (advice) .....	138, 233
Weights .....	265, 269
Wheel, spare .....	202, 203
Window controls .....	66
Wiper blades (changing) .....	156, 228
Wiper, rear .....	154
Wipers .....	22, 153, 155
Wipers, automatic rain sensitive .....	153, 155















Labels are applied at various points on your vehicle. They carry safety warnings as well as vehicle identification information. Do not remove them: they form an integral part of your vehicle.

For any work on your vehicle, use a qualified workshop that has the technical information, skills and equipment required, all of which a CITROËN dealer is able to provide.

Automobiles CITROËN declares, by application of the provisions of the European legislation (Directive 2000/53) relating to End of Life Vehicles, that it achieves the objectives set by this legislation and that recycled materials are used in the manufacture of the products that it sells.

Reproduction or translation of all or part of this document is prohibited without written authorisation from Automobiles CITROËN.

**We draw your attention to the following points:**

- The fitting of electrical equipment or accessories not listed by CITROËN may cause faults and failures with the electrical system of your vehicle. Contact a CITROËN dealer for information on the range of recommended accessories.
- As a safety measure, access to the diagnostic socket, used for the vehicle's electronic systems, is reserved strictly for CITROËN dealers or qualified workshops, equipped with the special diagnostic tool required (risk of malfunctions of the vehicle's electronic systems that could cause breakdowns or serious accidents). The manufacturer cannot be held responsible if this advice is not followed.
- Any modification or adaptation not intended or authorised by Automobiles CITROËN or carried out without meeting the technical requirements defined by the manufacturer would lead to the suspension of the legal and contractual warranties.

Printed in the EU  
Anglais

08-15

4Dconcept  
Diadeis  
Interak

Automobiles CITROËN

Siège social : 6, rue Fructidor 75017 Paris - France

Tél. : +33 (0) 1 58 79 79 79 - [www.citroen.com](http://www.citroen.com)

Société anonyme au capital de 159 000 000 € - R.C.S. : 642 050 199 R.C.S. Paris - SIRET : 642 050 199 00990 - APE : 7010Z



DS AUTOMOBILES

SPIRIT OF  
AVANT-GARDE

15DS5.0041  
Anglais

[driveDS.com](http://driveDS.com)

SUPPLEMENT

# DS 5 Hybrid 4x4



DS AUTOMOBILES



# On-line handbook

Select one of the following means of access to view your handbook on-line...

Find your handbook on the CITROËN website, under "MyCITROËN".

This personal and customisable space allows you to establish direct and special contact with the manufacturer.

---

Referring to the handbook on-line also gives you access to the latest information available, easily identified by the bookmark, associated with this symbol:



If the "MyCITROËN" function is not available on the CITROËN public website for your country, you can find your handbook at the following address:

<http://service.citroen.com/ddb/>

Select:

- > the language,
  - > the vehicle, its body style,
  - > the print edition of your handbook appropriate for the date of registration of your vehicle.
- 

Scan this code for direct access to your handbook.





DS AUTOMOBILES

Your vehicle will be fitted with only some of the equipment described in this document, depending on its trim level, version and the specification for the country in which it was sold.

The descriptions and illustrations are given as indications only.  
Automobiles CITROËN reserves the right to modify the technical characteristics, equipment and accessories without having to update this edition.

This document forms an integral part of your vehicle. Remember to pass it on to the new owner in the event of the sale of the vehicle.

We thank you for having chosen a DS 5 Hybrid 4x4.

This document presents the characteristics of operation and the recommendations on use for versions that have the Hybrid4 system.

Refer to the DS 5 handbook for all other descriptions and characteristics, as well as the maintenance and warranty guide for information of servicing your vehicle.

Take the time to read through them.

Happy motoring!





---

## HYBRID4 SYSTEM

- 4 Presentation
- 8 Instrument panel
- 9 READY lamp
- 9 Power indicator
- 10 Display of energy flows
- 12 Fuel consumption histogramme
- 13 Trip computer
- 15 Starting / switching off
- 19 Mode selector
- 22 "ECO OFF" function
- 23 Driving recommendations
- 24 Eco-driving
- 25 Special aspects of ZEV mode
- 27 High voltage battery
- 30 Underbonnet

---

## 003 COMFORT

- 31 Boot fittings

---

## 004 DRIVING

- 32 Electronic gearbox

---

## 008 PRACTICAL INFORMATION

- 36 Car washing machine or tunnel
- 37 Temporary puncture repair kit
- 38 Recovery on a flat-bed
- 38 Snow chains

---

## 010 TECHNICAL DATA

- 39 Electric motor
- 40 Diesel engine
- 41 Weights

## 42 FREQUENTLY ASKED QUESTIONS

## 45 ALPHABETICAL INDEX

# Presentation of the Hybrid4 system

The Hybrid4 technology associates two sources of power: an HDi Diesel engine, which drives the front wheels and an electric motor, which drives the rear wheels.

These two motors can operate alternately or simultaneously, according to the Hybrid4 operating mode selected and the driving conditions.

The electric motor alone provides power for the vehicle in **ZEV** (Zero Emissions Vehicle) mode, and in **AUTO** mode when running at slow speed and under low load. The electric motor also assists the HDi Diesel engine when moving off, accelerating and changing gear. The electric motor is powered by a high voltage battery that is recharged during phases of deceleration as well as, up to a certain threshold, by the HDi Diesel engine.

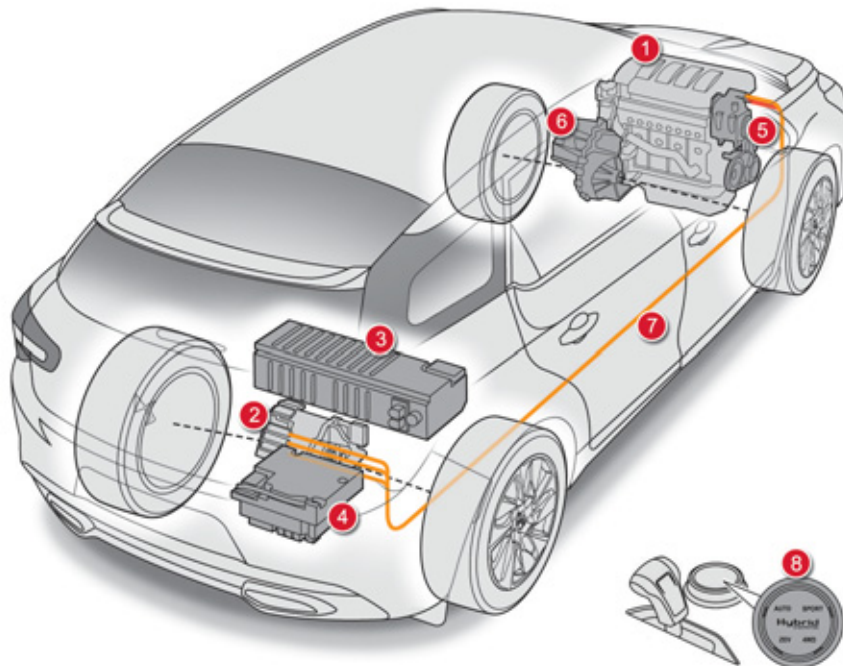

1. HDi Diesel engine (driving the front wheel).
2. Electric motor (driving the rear wheels).
3. 200 V high voltage battery.
4. Electronic power supervisor.
5. Alternator-starter motor (Stop & Start).
6. Electronic gearbox (ETG6).
7. Electrical flow.
8. Mode selector.

## Main parts of the Hybrid4 system

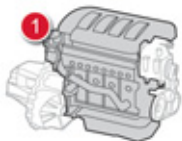

The **HDi Diesel engine (1)**, located at the front, drives the front wheels and provides most of the power needed to drive the vehicle.

Your Hybrid4 vehicle is fitted with effective emissions control systems, including the **Particle Filter (FAP)**.

During particle filter regeneration phases, the HDi engine is called on to produce the temperatures needed for combustion of the particles.

Electric running is temporarily unavailable and is accompanied by the display of a message "**Electric mode not available: FAP regeneration in progress**".

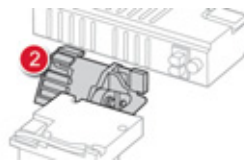

The **electric motor (2)**, located at the rear of the vehicle, drives the rear wheels on its own, or supplements the HDi Diesel engine, according to the Hybrid4 operating mode selected.

This electric motor also manages the recovery of energy, the charging of the batteries during phases of deceleration of the vehicle. It is active up to 70 mph (120 km/h).

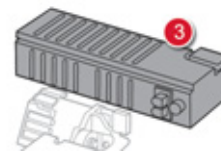

The **200 V high voltage battery (3)**, using Ni-MH technology, stores and delivers the energy needed for operation of the electric motor. Its state of charge is managed automatically by the electric motor during phases of deceleration or by the HDi Diesel engine below a certain threshold.

This high voltage battery is located in a special compartment under the boot floor. Access to it is strictly restricted to technicians at a CITROËN dealer or a qualified workshop.

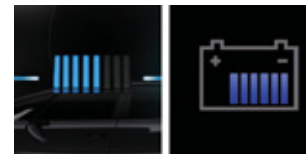

The **state of charge** of the high voltage battery is represented graphically by bars. See the "Display of energy flows" section.



The **12 V battery**, located under the bonnet, powers the vehicle's conventional electrical system. It is used for starting the HDi Diesel engine and the operation of the vehicle's equipment, such as the lighting, wipers, audio system...

This 12 V battery is recharged automatically by the high voltage network.

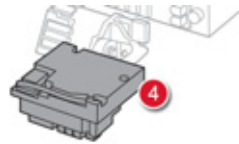

The **electronic power supervisor (4)** manages the operation of the two power units, HDi Diesel and electric, giving priority to low fuel consumption.

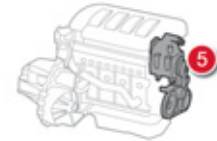

The **alternator-starter motor (5)** assures the **Stop & Start** function, which allows the HDi Diesel engine to be put into standby when the vehicle is at a standstill (traffic lights, a stop, or in a traffic jam...) or during phases of running in 100% electric mode.

The stopping and restarting of the HDi Diesel engine is done automatically and instantly without any action on the part of the driver. This alternator-starter motor also provides additional charging of the high-voltage battery by the HDi Diesel engine, if this not sufficiently charged, or in **4WD** mode for example.

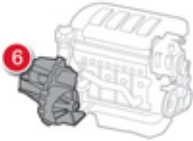

Compared to a manual gearbox, the **ETG6 electronic gearbox (6)** provides, in automatic mode, significant savings in fuel consumption, through the electronic management of gear changes.



The **mode selector (8)** allows selection of the four operating modes offered by the Hybrid4 system:

- **AUTO** mode, which optimises fuel consumption by automatically managing the alternate or simultaneous use of the two motors,
- **ZEV** (Zero Emissions Vehicle) mode, which provides 100% electric drive, when the driving conditions and the state of charge of the battery permit,
- **SPORT** mode, which provides more dynamic driving with additional performance,
- **4WD** (4 Wheel Drive) mode, which improves traction at low speed when grip is poor (snow, mud, sand...).

# Instrument panel



## Dials and screens

1. Power indicator (%).  
Display of the percentage of the total power available supplied by the Hybrid4 system, or the energy recovered.
2. Selector position and gear engaged for the electronic gearbox or gear shift indicator.
3. Speed limiter or cruise control settings.
4. READY lamp: indicates that the vehicle is ready to drive.
5. Engine coolant temperature gauge (°Celsius).
6. Analogue speedometer (mph or km/h).
7. Digital speedometer (mph or km/h).
8. Fuel gauge.
9. Instrument panel screen:
  - permanent display of distance recorders, and, as desired\*: trip computer, energy flows, current media playing or navigation instructions,
  - temporary display: service indicator, engine oil level indicator, alert messages.

## Control buttons

- A.** Main lighting and controls dimmer.
- B.** - Successive short presses: under-inflation detection, recall servicing information, alert log.
- Long press: reset the function selected to zero (service indicator or trip recorder).

\* By successive presses on the end of the wiper control stalk.

## READY lamp

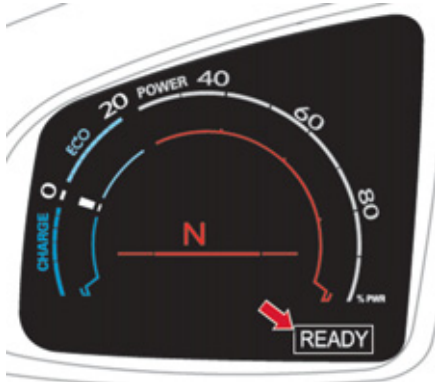

### READY

When the Hybrid4 system is started, this indicator lamp comes on to signal that the vehicle is ready to move off.

Illumination of this indicator lamp is more or less instant but may take a few seconds in some cases (pre-heating the HDi Diesel engine in cold weather or in energy economy mode...).

- ⚠ Never leave the Hybrid4 system on when leaving the vehicle, or opening the bonnet, refuelling... Before leaving the vehicle, ensure that the **READY** lamp is off.

## Power indicator

The indicator dial displays information on the total power used in real time, combining electric and Diesel.

It comprises three operating zones.

### ECO zone



Indicates that the vehicle is **optimising its energy consumption**, electric, Diesel or a combination of both.

This zone corresponds to phases of electric running as well as to phases of optimum use of the HDi Diesel engine, which are easily accessible with a suitable driving style (smooth "eco-citizen" driving).

### CHARGE zone



Indicates that the vehicle is in an electrical **energy recovery** phase: on deceleration, braking (partially) or particularly with your foot off the accelerator.

This allows the high voltage battery to be recharged using **"free" energy** which can then be **reused** for future energy requirements.

### POWER zone

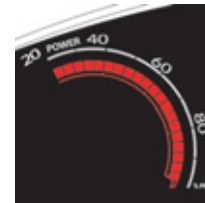

Indicates an increased cumulative **power demand** from your vehicle, taking account of the combined power available from the HDi Diesel engine and the electric motor.

# Display of energy flows

Information on the Hybrid4 mode selected (1, 2), arrows for energy flows (6 to 9) and the state of charge of the high voltage battery (4), is displayed in real time in the instrument panel screen or the touch screen.

See the "Trip computer" section.

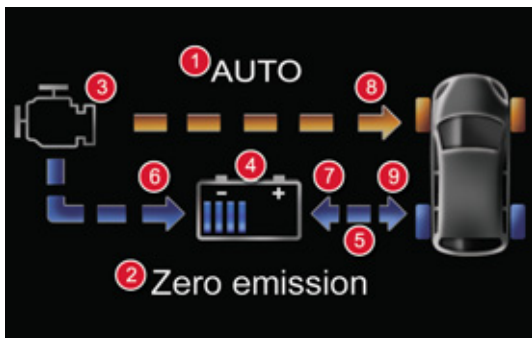

Display of flows in the instrument panel

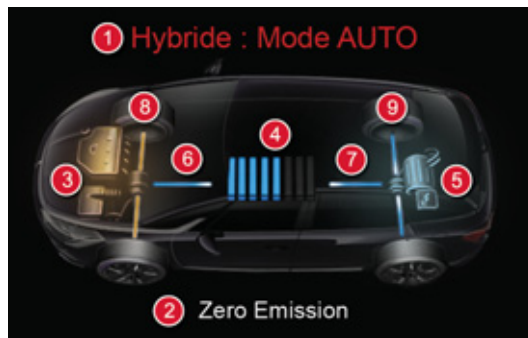

Display of flows in the touch screen

## Hybrid4 modes

1. Hybrid4 mode selected (**AUTO**, **ZEV**, **SPORT** or **4WD**).
2. "**Zero Emission**" messages if the HDi Diesel engine is stopped (0 g/km CO<sub>2</sub>).

## Vehicle infrastructure

3. HDi Diesel engine.
4. State of charge of the high voltage battery.
5. Electric Motor/Generator.

## Operation / Energy flows

6. The HDi Diesel engine supplies the battery (as needed).
7. Arrow from left to right: the battery powers the electric motor (when the electric motor is operating).  
Arrow from right to left: the electric motor/generator recharges the battery (energy recovery phases).
8. The HDi Diesel engine drives the front wheels.
9. The electric motor drives the rear wheels.



## On starting and when stationary

There is no flow of energy; the Stop & Start alternator-starter stops and restarts the HDi Diesel engine automatically, whatever the operating mode selected.



## Energy recovery

During this phase (deceleration, braking, foot off the accelerator, ... all modes), the high voltage battery is recharged by the electric motor/generator, then being driven by the rear wheels.

You can maximise this energy recovery by taking your foot off the accelerator pedal; deceleration will be less marked than with a conventional vehicle.



## 100% electric

In all electric running (**AUTO** or **ZEV** modes), only the electric motor drives the vehicle, via the rear wheels, powered by the high voltage battery.

The display of "**Zero Emission**" indicates that the HDi Diesel engine is stopped and the vehicle is producing no CO<sub>2</sub>.



# Fuel consumption histogram (Only with touch screen)

## Fuel consumption

This graph represents the history of average fuel consumption figures.

It is accessible via the "**Driving**" menu of the touch screen.

These figures are calculated over the last 30 minutes in periods of 5 minutes.

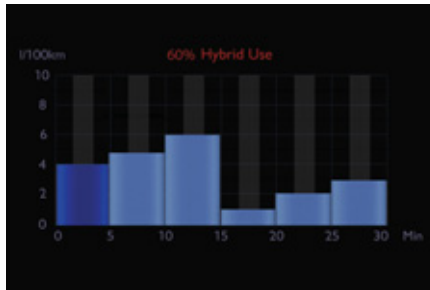

**60 % Hybrid Use** corresponds to 60 % of the cumulative running time with the addition of the Hybrid4 system and 40 % of the time with the Diesel engine only.



For more information on the trip computer, refer to the corresponding section.

# Trip computer

System that gives you information on the current journey (range, fuel consumption...).

## Instrument panel screen



## Information display

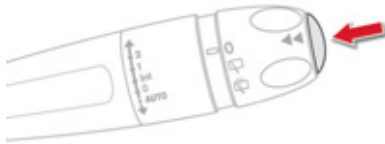

☞ Press the end of the **wiper control stalk** to display the various tabs in succession.



- The current information tab with:
  - the range,
  - the current instantaneous fuel consumption.



- Trip "1" with:
  - the average speed,
  - the average fuel consumption, for the first trip.



- Trip "2" with:
  - the average speed,
  - the average fuel consumption, for the second trip.

- The energy flows.
- The radio or media playing.
- Navigation instructions.

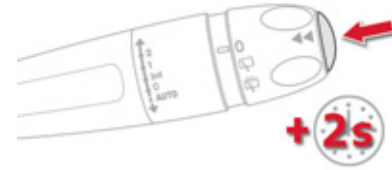

## Resetting the trip recorder

☞ When the desired trip is displayed, press the end of the wiper control stalk for more than two seconds.

Trips "1" and "2" are independent but their use is identical.

For example, trip "1" can be used for daily figures, and trip "2" for monthly figures.

## Resetting the histogramme (Only with touch screen)

☞ When trip "2" is displayed, press the end of the wiper control stalk for two seconds to reset the fuel consumption histogramme.

## Touch screen



1. "Instantaneous".
2. "Trip 1".
3. "Trip 2".
4. "Hybrid".
5. "Histogram".
6. "00.0 / Reset".

## Information display

**DRIVE** ☞ Select the "Driving" menu.

The trip computer information is displayed in the primary page of the menu.

☞ Press one of the buttons to display the desired tab.

The current instantaneous fuel consumption tab with:

- the range,
- the current fuel consumption.

The trip "1" tab with:

- the average speed,
- the average fuel consumption, for the first trip.

The trip "2" tab with:

- the average speed,
- the average fuel consumption, for the second trip.

The energy flows.

The fuel consumption histogram.

## Trip reset

 ☞ When the desired trip is displayed, press the reset button or press and hold the end of the wiper control stalk.

Trips "1" and "2" are independent but their use is identical.

For example, trip "1" can be used for daily figures, and trip "2" for monthly figures.

## Resetting the histogram

☞ When trip "2" is displayed, pressing the reset button also resets the fuel consumption histogram.

# Starting - switching off the Hybrid4 system

## Starting the Hybrid4 system

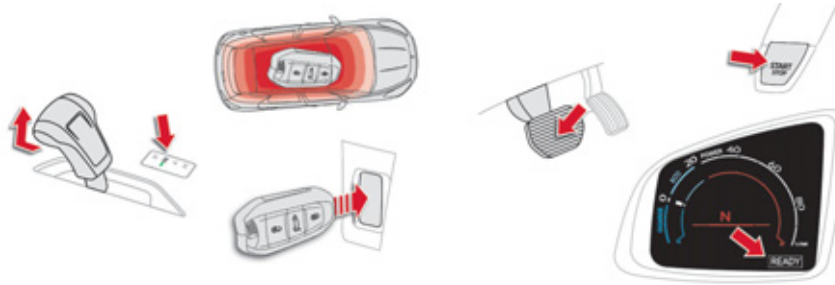

## Activation of the Hybrid4 system

- ☞ Place the gear selector at position **N**.
- ☞ Insert the electronic key in the reader.  
or
- ☞ With Keyless Entry and Starting, simply having the electronic key inside the vehicle is sufficient.
- ☞ **Press the brake pedal firmly.**
- ☞ Make a single short press (about one second) on the "**START/STOP**" button.
- ☞ Maintain pressure on the brake pedal until the **READY** lamp comes on, signalling activation of the Hybrid4 system, confirmed by an audible signal.

- 📘 If the Hybrid4 system does not activate:
  - ☞ If **N** is flashing in the instrument panel, move the gear selector to position **A** then to position **N**.
  - ☞ If the "**Foot on the brake**" is displayed, press the brake pedal firmly.

On activation of the Hybrid4 system, the instrument panel lights up, the power indicator needle is placed at position "**0**". The steering column automatically unlocks (perceptible noise and movement of the steering column). Depending on certain parameters, such as the state of charge of the high voltage battery or the ambient temperature, the Hybrid4 system itself determines whether it is necessary to start the HDi Diesel engine. The mode selector is at the **AUTO** position.

🚫 Never leave children alone inside the vehicle when the Hybrid4 system is active.

📘 🛑 In wintry conditions with the engine cold, the Diesel pre-heating warning lamp can stay on for a few seconds; wait until it goes off before releasing the brake pedal.

📘 The **READY** lamp may come on after a few seconds if there is a demand for activation of the Hybrid4 system after energy economy mode has been entered.

## Moving off

- ☞ Move the gear selector to position **A** (automatic mode) or **M** (manual mode) or **R** (reverse).

 Using automatic mode with the electronic gearbox optimises gear changes and so gives more economical driving.

- ☞ If automatic operation of the electric parking brake has been deactivated, pull then release the control lever to release the parking brake manually.
- ☞ Progressively release the brake pedal.
- ☞ With the parking brake released, the vehicle then moves off.

If the parking brake is still applied and is in automatic mode, accelerate progressively.

 For more information on the electric parking brake, refer to the corresponding section in the handbook for the vehicle.

You can change the operating mode of the Hybrid4 system at any time using its mode selector.

Driving in **ZEV** mode requires that particular conditions be met.

 When your vehicle moves off in electric mode, it makes no noise. Be very careful of pedestrians, cyclists... as, because of this, they will not hear you coming.

## Head-up display

The colour of the speedometer varies according to the drive train used:

- white display: Diesel engine running,
- blue display: Diesel engine stopped.

## Switching off the Hybrid4 system

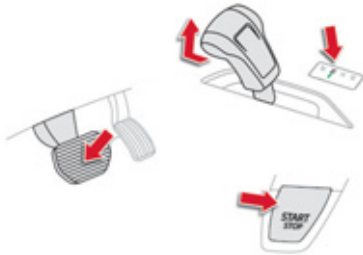

- ☞ Immobilise the vehicle.
- ☞ Place the gear selector in position **N**.
- ☞ Make a short press (about one second) on the "**START/STOP**" button.

The Hybrid4 stops:

- the **READY** lamp goes off,
- the steering column locks,
- the electric parking brake is applied automatically, unless its automatic mode is deactivated.
- ☞ Check that the parking brake warning lamps are on.
- ☞ Remove the electronic key from the reader.

⚠ Check that the **READY** lamp is off before leaving the vehicle. Never leave the electronic key in the vehicle in your absence.

⚠ Before doing anything under the bonnet, the Hybrid4 must be switched off (**READY** lamp off) and the electric parking brake must be applied.

⚠ For reasons of safety and theft protection, do not leave your electronic key in the vehicle, even when you are close to it. It is recommended that you keep it on your person.

## Switching the ignition on

With the electronic key in the reader or the Keyless Entry and Starting key inside the vehicle, pressing the "**START/STOP**" button, **with no action on the brake pedal**, allows the ignition to be switched on.



☞ Press the "**START/STOP**" button, the instrument panel comes on but the Hybrid4 system does not start up.

☞ Press this button again to switch off the ignition and so allow the vehicle to be locked.

⚠ With the ignition on, the system goes into energy economy mode when necessary to maintain the state of charge of the battery.

## Back-up starting / emergency switching off

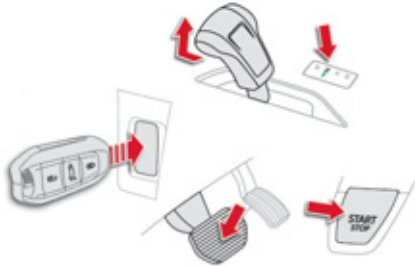

### Back-up starting with the Keyless Entry and Starting system

When the electronic key is in the recognition zone and after pressing the "START/STOP" button, the Hybrid4 system does not start up:

- ☞ Insert the electronic key in the reader.
- ☞ Place the gear selector at position **N**.
- ☞ Press the brake pedal firmly.
- ☞ Press the "START/STOP" button.

The Hybrid4 starts up; the **READY** lamp is on.

### Emergency switching off



In the event of an emergency only, the engine can be switched off without any conditions.

- ☞ To do this, press and hold the "START/STOP" button for about 3 seconds.

In this case the steering column locks as soon as the vehicle stops.

 The electronic key must always remain inside the vehicle when in use.

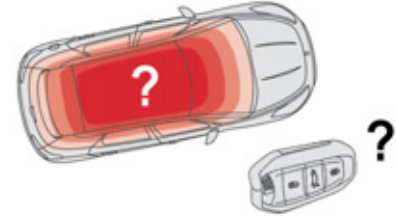

### Electronic key not recognised with Keyless Entry and Starting

If the electronic key is no longer in the recognition zone when driving or when you (later) request switching off of the Hybrid4 system, a message appears in the instrument panel.



- ☞ Press and hold the "START/STOP" button for about 3 seconds if you want to force the Hybrid4 system to switch off.

 Note that restarting will not be possible without the presence of the electronic key in the recognition zone.



# Mode selector

The selector allows the driver to select one of the four operating modes offered by the Hybrid4 system.

☞ Turn the dial to the right or left; the mode selected is confirmed by illumination of the corresponding indicator lamp.

**i** By default, the selector is in the **AUTO** position when starting the Hybrid4 system, whatever position it was in when the ignition was switched off.

**AUTO** mode: for everyday use and optimised fuel consumption.

**SPORT** mode: to make use of the maximum performance of the vehicle.

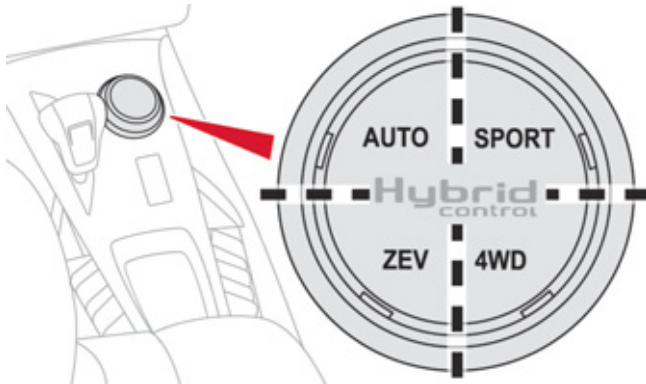

**ZEV** mode: for 100% electric running.

**4WD** mode: to force 4x4 drive in conditions of poor grip.



## AUTO mode

This mode is designed to optimise the vehicle's fuel consumption by managing the alternate or simultaneous operation of the two motors according to the conditions and driving style. When conditions allow, an adequate battery state of charge and moderate acceleration, the alternator-starter motor stops the HDi Diesel engine to provide 100% electric running.



## ZEV mode (all electric)

In **AUTO** mode, the **electric motor**:

- can power the vehicle on its own in "zero emissions" electric running, depending on the state of charge of the battery, if the conditions specific to the vehicle are met and if acceleration is moderate,
- **supplements the HDi Diesel engine** when moving off and changing gear, during acceleration or when traction from the front wheels is inadequate, temporarily providing 4-wheel drive.

The electric motor can operate only at speeds below 52 mph (85 km/h). It is no longer active above 75 mph (120 km/h).

Zero emissions vehicle operation is assured 100 % by electric drive.

This mode allows **silent and clean running** at moderate speeds.

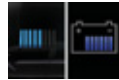

It can be activated when the conditions allow, particularly if the state of charge of high voltage battery is sufficient (from 4 bars).

Refer to the special conditions for operation of **ZEV** mode.

If the conditions do not allow **ZEV** mode to be selected or maintained, the message "**Electric mode is not currently available**" appears in the screen. The **ZEV** indicator lamp flashes for a few seconds then goes off and the indicator lamp in the **AUTO** position comes on.

In **ZEV** mode:

- range and acceleration capacity are limited; the maximum speed is around 36 mph (60 km/h),
- under high load or a priority requirement causing the start of the HDi Diesel engine, the system changes automatically to **AUTO** mode.

 For more information on the special conditions for the operation of **ZEV** mode, refer to the corresponding section.



## SPORT mode (Diesel and electric)

This mode allows more dynamic driving by providing **additional performance**.

By using the capacity of the electric motor to supplement the power of the HDi Diesel engine, the vehicle's full power is used for acceleration and pick-up.

This mode manages the response of the accelerator, the electronic gearbox and the use of the electric motor.

In **SPORT** mode:

- the electric motor as an addition is available up to 75 mph (120 km/h).



## 4WD mode (4-wheel drive)

This "4-wheel drive" mode provides **additional traction** at low speed by driving all four wheels of the vehicle simultaneously: the HDi Diesel engine (front wheel drive) and the electric motor (rear wheel drive) operate simultaneously and permanently.

Their coupling is managed electronically to optimise traction when grip is poor.

In **4WD** mode:

- the HDi Diesel engine operates continuously; if necessary, it supplies energy for the electric motor,
- the additional traction from the electric motor is available up to 75 mph (120 km/h).



- This mode is available whatever:
- the state of charge of the high voltage battery,
  - the altitude.



This mode should be used on snow covered roads or difficult ground (mud, sand, ...), as well as for crossing a ford, at moderate speed.

In this mode, in severe conditions and if the circumstances allow, it is recommended that you accelerate strongly to facilitate moving off and making progress and so reduce the risk of getting stuck.



This mode will be even more effective if the vehicle is fitted with suitable tyres, such as winter tyres.

# "ECO OFF" function



This function prevents the HDi Diesel engine being switched off and ensures that a comfortable temperature can be maintained in the passenger compartment. This therefore allows the air conditioning or heating to be kept running.

Depending on version, the control is either in the switch panel alongside the steering wheel, or in the **"Driving"** menu of the touch screen.

On pressing the **ECO OFF** switch, the HDi Diesel engine restarts immediately and then operates continuously. The indicator lamp in the control comes on.

Pressing this control again deactivates the function.

The indicator lamp in the control goes off. The Hybrid4 system returns to normal operation.

 The function is deactivated on switching off the ignition.

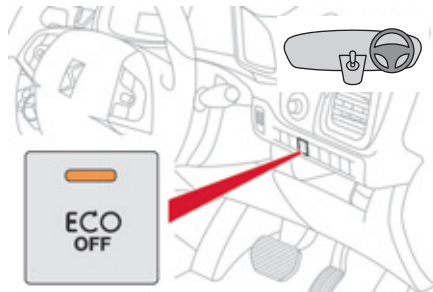

## With the switch on the dashboard

 Press this switch.

Deactivation is confirmed by the illumination of the indicator lamp in the control switch and the display of a message.

Pressing the switch again reactivates the system. The indicator lamp in the switch goes off, accompanied by the display of a message.

## With the touch screen button

**DRIVE**  Select the **"Driving"** menu.

**ECO OFF**  In the page, press this button.

Deactivation is confirmed by the illumination of the indicator lamp for the button and the display of a message.

Pressing the button again reactivates the system.

The indicator lamp for the button goes off, accompanied by the display of a message.

 During phases of electric running and when the internal combustion engine is stopped, the Hybrid4 system manages restarting automatically to maintain the temperature in the passenger compartment\*. However, variations in temperature may still be felt in very high ambient temperatures. In this case, activate the **ECO OFF** function.

\* Except in **ZEV** mode, which gives preference to electric running over maintaining a comfortable temperature.

## Driving recommendations

Observe the driving regulations and remain vigilant whatever the traffic conditions.

Pay close attention to the traffic and keep your hands on the wheel so that you are ready to react at any time to any eventuality.

On a long journey, a break every two hours is strongly recommended.

In difficult weather, drive smoothly, anticipate the need to brake and increase the distance from other vehicles.

### Driving on flooded roads

We strongly advise against driving on flooded roads, as this could cause serious damage to the internal combustion engine or electric motor, the electronic gearbox, or the electrical systems of your vehicle.

If you are obliged to drive through water:



- check that the depth of water does not exceed 15 cm, taking account of waves that might be generated by other users,
- place the mode selector in the **4WD** position,
- drive as slowly as possible without stalling. In all cases, do not exceed 6 mph (10 km/h),
- do not stop and do not switch off the engine.

On leaving the flooded road, as soon as circumstances allow, make several light brake applications to dry the brake discs and pads.

If in doubt on the state of your vehicle, contact a CITROËN dealer or a qualified workshop.

### Important!

**!** Never drive with the parking brake applied - Risk of overheating and damage to the braking system!  
Do not park or run the engine when stationary in areas where inflammable substances and materials (dry grass, dead leaves...) might come into contact with the hot exhaust system or certain components of the Hybrid4 system which can reach very high temperatures - Risk of fire!

**!** Never leave a vehicle unsupervised with the engine running. If you have to leave your vehicle with the engine running, apply the parking brake and put the electronic gearbox into position **N**.

# Eco-driving



Eco-driving is a range of everyday practices that allow the motorist to optimise their fuel consumption and CO<sub>2</sub> emissions.

## Adapted to your Hybrid4 vehicle

Use gear selector position **A**, as this optimises gear changes to suit the circumstances, and the **AUTO** mode of the Hybrid4 mode selector.

When moving off, accelerate normally up to the desired speed (**POWER** zone between 20 and 40 %).

At steady speeds, drive gently with small movements of the accelerator pedal (**ECO** or **CHARGE** zone), to allow running in electric mode when driving at low speed.

Anticipate the need to slow down and use engine braking (**CHARGE** zone), so as to make use of the recovery of "free" energy, while maintaining light pressure on the accelerator pedal.



For information on other eco-driving practices, refer to the corresponding section of the handbook for the vehicle.

# Special conditions for the operation of ZEV mode

**ZEV** mode can be selected when all of the conditions for its operation are met, in particular an adequate state of charge of the battery (50% at least).

In the situations described below, the HDi Diesel must be running; accordingly, **ZEV** mode cannot be selected or is deactivated automatically. The mode selector remains at or returns to the **AUTO** position to allow starting of the HDi Diesel engine.

## Cases of non availability of ZEV mode or automatic return to AUTO mode

### Action by the driver:

- Manual gear change when in automatic mode using the steering mounted controls for the electronic gearbox.
- Selection of manual mode by moving the gear selector for the electronic gearbox to position **M**.
- Sustained and sharp acceleration.
- Use of demisting / defrosting.
- Intensive use of air conditioning.

## Maintaining the performance of the system:

- If the state of charge of the high voltage battery is lower than 4 bars (equal to 50% charged). In **AUTO** mode, electric operation is possible with a lower state of charge.
- When the speed of the vehicle exceeds 18 mph (30 km/h), if the internal combustion engine has not already started at least once since the Hybrid4 system was started.
- When the fuel level enters the reserve zone (illumination of the low fuel warning lamp). Where this reserve is being used up quickly, **ZEV** may not be possible for some time after refuelling.
- During phases of regeneration of the particle filter (FAP), which is automatically triggered approximately every 300 miles (500 kms) for a period of about 10 minutes. During regeneration of the particle filter, the particles are brought up to a high temperature using the HDi Diesel engine; A message is then displayed: "**Electric mode not available: FAP regeneration**".

## Unsuitable circumstances:

- If certain conditions or engine temperature requirements needed by the HDi Diesel engine are not met (for example, in wintry conditions).
- Following a prolonged period with the vehicle parked in the sun.
- When the state of charge of the high voltage battery is close to the maximum level (for example: when going down a long hill using the electric motor for braking), recovery of the vehicle's kinetic energy being no longer possible, the HDi Diesel engine restarts automatically just to provide engine braking.
- On a steep rising slope.
- Driving at altitude.



# 200 V high voltage battery

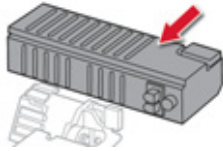

The Ni-Mh (Nickel-Metal Hydride) technology used for the high voltage battery is suited to the frequent partial charging and discharging cycles related to the operation of a hybrid vehicle.

The battery is installed close to the electric motor, below the boot trim, behind the storage well.



To preserve the service life of the battery, the level of charge never falls below 20%, even if no bars are displayed on the gauge after **ZEV** running.

Where the battery is close to maximum, vehicle deceleration with your foot off the accelerator pedal will be at a lower level.

## Charging

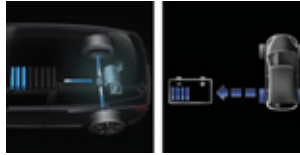

The battery recharges automatically while travelling.

The battery is charged when the vehicle decelerates and when going downhill, the electric motor then becomes a generator and converts kinetic energy into electrical energy (except if the speed of the vehicle is above 70 mph (120 km/h)).

This recovery allows the use of "free" energy. The battery may also be partially charged up to a level of 4 to 5 bars, using the alternator-starter motor (Stop & Start) of the HDi Diesel engine.



The battery is not recharged from a mains power supply.

The battery charging time is very short.

Once it is discharged, following **ZEV** running or high load, the battery will reach its optimum level of charge after around 10 minutes.

The average state of charge is 4 to 5 bars, so preserving a margin for energy recovery when deceleration or going downhill (free energy).

## Safety warnings related to high voltage

The voltage used for the operation of the electric motor is in the range 150 to 270 Volts.

Do not handle the components of the high voltage system (identified by the orange colour): risk of electrocution and burns!

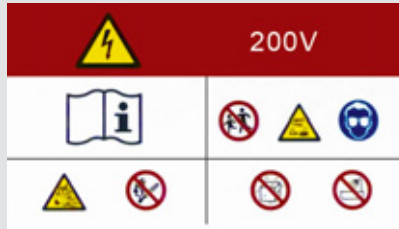

Be sure to take account of the warning labels present on the vehicle.

Battery electrolyte is very corrosive: risk of burns.

No sparks or naked flames.

Do not burn or heat.

Keep out of reach of children.

Do not spray or pour fluids: risk of damage to the battery.

**READY**

Before doing any work on the vehicle, switch off the ignition (**READY** lamp off).

High voltage cables are routed under the vehicle (sills); take care not to damage them when the vehicle is used for off-road activity (such as covering rough ground).

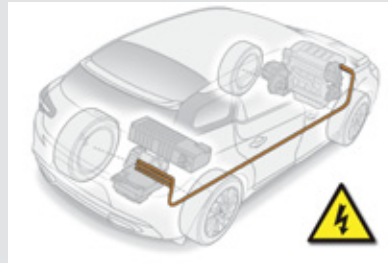

Never touch, dismantle, remove or replace the high voltage parts, orange cables or connectors, even in the event of an accident.

Take care to position lifting equipment (jack, hoist, ...) at the locations provided to avoid damaging the cables.

## Operations on the battery

The high voltage battery must not in any circumstances be charged from an external power supply and must only be handled by a qualified technician at a CITROËN dealer or a qualified workshop.

Incorrect handling may lead to serious burns, as well as electric arcs that could cause serious injury or even death.

## Emergency cut-off

In the event of an accident, a safety system automatically cuts-off the high voltage system and the fuel supply. The Hybrid4 system can no longer be started.

You must then contact a CITROËN dealer or a qualified workshop.



To avoid any risk to the environment, the high voltage battery must be recycled in an appropriate manner. Contact a CITROËN dealer or a qualified workshop.

## Ventilation of the high voltage battery

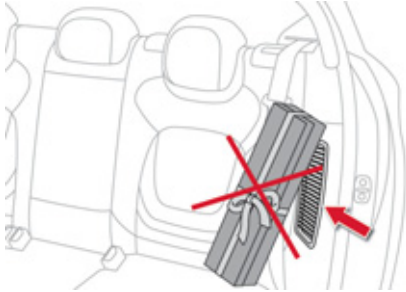

The high voltage battery has an air cooling system. This comprises an air intake (located on the side of the left hand rear seat) and a fan (located behind the left hand boot trim panel).

This ventilation system does not operate at the same speed at all times: it is continuously adjusted to suit the cooling requirements of the battery.

The noise of its operation can be heard, particularly at the rear, after the Hybrid4 system is switched off (post-ventilation).

### Safety recommendations

Do not obstruct the air intake with objects such as clothes or bags, in order to avoid any risk of the battery overheating, which could cause a loss of performance of the Hybrid4 system, even damage to the battery.

Do not spill fluids, as this may damage the battery and cause a short-circuit.

# Access to the underbonnet

## Recommendations

**READY**

Always ensure that the ignition is switched off (**READY** lamp off) before opening the bonnet.

The alternator-starter motor of your Hybrid4 vehicle is also supplied at high voltage. If the vehicle ignition has not been switched off, there is a risk of the engine restarting at any time.

 Before doing anything under the bonnet, you must switch off the ignition and verify that the **READY** lamp in the instrument panel is off - risk of serious injury!

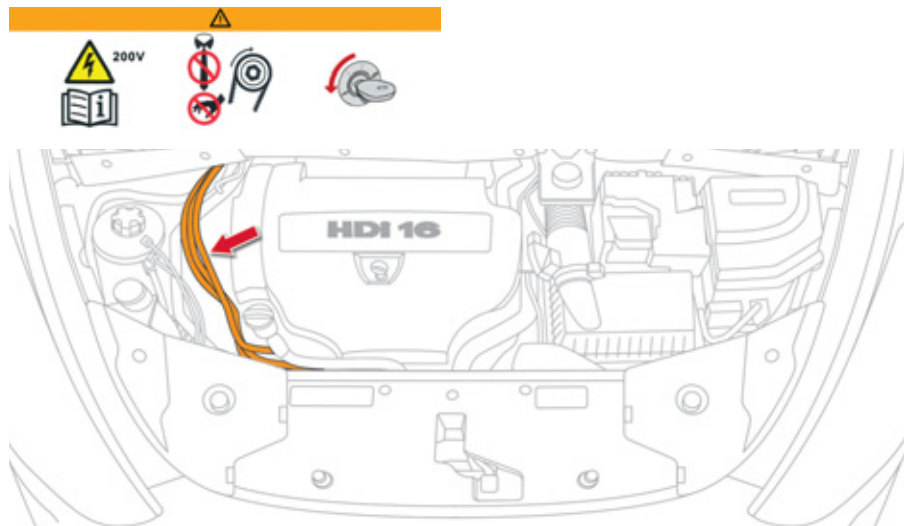

# Boot fittings

## 1. Rear parcel shelf

It can be removed to allow large objects to be carried.

## 2. Bag hooks

## 3. Retaining straps

These are provided to stow a warning triangle.

## 4. Removable boot floor

Lift the floor using its grip and follow the guides.

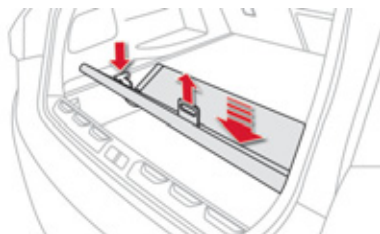
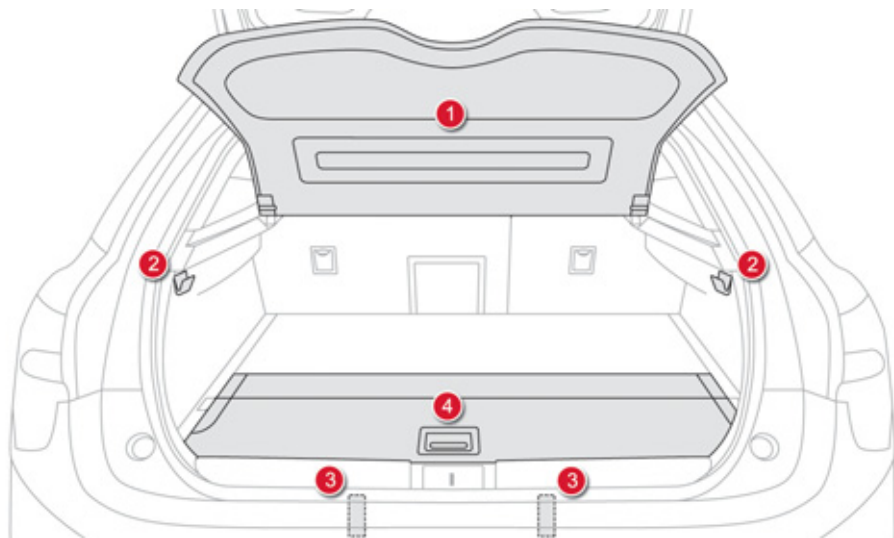

# Electronic gearbox (ETG6)

Six-speed electronic gearbox which offers a choice between two operating modes:

- **automated** mode for automatic control of the gears by the gearbox,
- **manual** mode for sequential gear changing by the driver.

In automated mode, it is possible to change gear manually by using the steering mounted control paddles as desired, when overtaking, for example.

## Gear selector

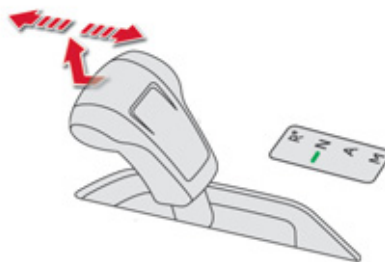

- R.** Reverse
  - ☞ With your foot on the brake, lift the selector and move it forwards.
- N.** Neutral.
  - ☞ With your foot on the brake, select this position to start.
- A.** Automated mode.
  - ☞ Move the selector backwards to select this mode.
- M.** Manual mode with sequential gear changing.
  - ☞ Lift the selector, then move it backwards to select this mode, then use the steering mounted control paddles to change gear.

**i** Engagement of reverse gear is accompanied by an audible signal.

## Steering mounted control paddles

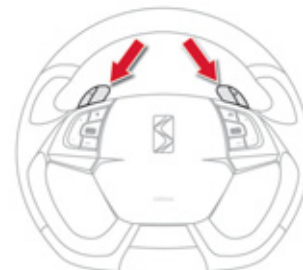

- +** Change up paddle to the right of the steering wheel.
  - ☞ Press the back of the "+" steering mounted paddle to change up a gear.
- Change down paddle to the left of the steering wheel.
  - ☞ Press the back of the "-" steering mounted paddle to change down a gear.

**i** The steering mounted paddles cannot be used to select neutral or to engage or disengage reverse gear.

**i** When immobilising the vehicle, with the Hybrid4 system active, you must place the gear selector in neutral **N**. Before carrying out any work in the engine compartment, check that the gear selector is in position **N**, that the parking brake is applied and that the **READY** lamp is off before switching off the Hybrid4 system.

## Displays in the instrument panel



**N** Neutral

**R** Reverse

**1, 2, 3, 4, 5, 6** Gears in manual mode

**A** This comes on when automated mode is selected. It goes off on changing to manual mode.



☞ Place your **foot on the brake** when a message appears in the instrument panel screen.



Before leaving the vehicle, place the gear selector in position **N** and then you must stop the Hybrid4 system by switching off the ignition (**READY** lamp off).

## Moving off



☞ To start the engine, place the gear selector in position **N**.

- ☞ Press the brake pedal down fully.
- ☞ Start the Hybrid4 system.



If the Hybrid4 system does not activate:

- If **N** is flashing in the instrument panel, move the gear selector to position **A** then to position **N**.
- If the message "**Foot on brake**" is displayed, press the brake pedal firmly.

- ☞ Select a drive mode (position **A** or **M**) or reverse (position **R**).



**A** or **M1** or **R** appears in the instrument panel screen.

- ☞ Release the parking brake by pulling the control lever, if automatic operation has been deactivated.
- ☞ Progressively release the brake pedal.

- ☞ If the parking brake is released, the vehicle moves off.

If the parking brake is applied and automatic mode is activated, accelerate progressively.

## Automated mode

- ☞ After starting the vehicle, select position **A** for enter automated mode.



**A** appears in the instrument panel screen.

The gearbox is then operating in auto-active mode, without any action on the part of the driver. It continuously selects the most suitable gear, depending on the:

- style of driving,
- profile of the road.



For optimum acceleration, for example when overtaking another vehicle, press the accelerator pedal firmly past the point of resistance.

## Manual gear changing

This selective gear change mode enables you to overtake, for example, while still remaining in automated mode.

☞ Operate the + or - steering mounted control paddle.

The gearbox engages the gear requested if the engine speed permits. **A** is still displayed in the instrument panel.

After a few moments without any action on the controls, the gearbox resumes automatic control of the gears.

## Manual mode

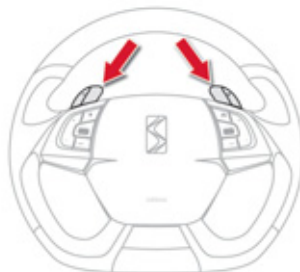

- ☞ When the vehicle has moved off, select position **M** to change to manual mode.
- ☞ Operate the + or - steering mounted control paddles.



**A** disappears and the gears engaged **M1...M6** appear successively in the instrument panel screen.

The gear change commands are only carried out if the engine speed permits. The internal combustion engine is still running.

It is not necessary to release the accelerator during gear changes.

When braking or slowing down, the gearbox changes down automatically to permit acceleration in the correct gear.

**i** At very low speed, if reverse gear is requested, this will only be taken into account when the vehicle is immobilised. A warning lamp appears in the instrument panel screen. Only engage reverse gear **R** when the vehicle is immobilised with the brake pedal pressed.

**!** On sharp acceleration in manual mode, the gearbox will not change up unless the driver acts on the gear lever or the steering mounted paddles. Never select neutral **N** while the vehicle is moving.





## Creep function

This function facilitates manoeuvring of the vehicle at low speed (when parking, in traffic jams, ...).

With the Hybrid4 hybrid system active, the vehicle stationary and the parking brake released:

- ☞ press the brake pedal,
- ☞ place the gear selector in position **A**, **R** or **M**,
- ☞ gradually release the brake pedal.

The vehicle moves off immediately and gradually reaches a speed of approximately 6 mph (10 km/h), with pressing the accelerator pedal.

 For your safety, this function will only be activated if you press the brake pedal when engaging forward drive or reverse.

This function is deactivated if the driver's door is opened. To reactivate it, close the door and then press the brake or accelerator pedal.

 Never leave children unsupervised in the vehicle with the Hybrid4 system active.

## Stopping the vehicle

Before switching off the Hybrid4 system, place the gear selector in position **N**.

When switching off the Hybrid4 system, the electric parking brake is applied automatically. If the automatic function is deactivated, apply the parking brake manually to immobilise the vehicle.

 Before leaving the vehicle, check that the parking brake lamps are on (not flashing) in the instrument panel and in the control lever.

 To immobilise the vehicle without applying the parking brake, before switching off the ignition, place the gear selector in position **A** or **R**.  
If the battery is flat, it is essential to place a chock against one of the wheels to immobilise the vehicle.

## Operating fault

### SERVICE

With the ignition on, the flashing of this warning lamp, accompanied by an audible signal and a message

in the instrument panel screen, indicates a malfunction of the gearbox.  
Have it checked by a CITROËN dealer or a qualified workshop.

# Car washing machine or tunnel



Some car washing machines or tunnels (where the vehicle is moved forwards on a travelling track) require that the parking brake be "released" during the wash.

If possible on your vehicle, deactivate the automatic operation of the electric parking brake in the vehicle systems configuration menu.

## Car washing machines or tunnels in which the HDi Diesel engine must be switched off.

- With the Hybrid4 system active, **READY** lamp on, parking brake released:
  - Place the gear selector at position **N**.
  - Switch off the Hybrid4 system (press the **START/STOP** button). The **READY** lamp goes off in the instrument panel and the parking brake is applied automatically.
  - Switch on the ignition again (press the **START/STOP** button) without your foot on the brake pedal. The **READY** lamp remains off.
  - Release the parking brake using the manual control on the centre console, while keeping your foot on the brake pedal.
  - Switch off the ignition (press the **START/STOP** button without your foot on the brake pedal) after having checked that the parking brake remains released.

## Car washing machines or tunnels in which the HDi Diesel engine must not be switched off.

- With the Hybrid4 system active, **READY** lamp on, parking brake released:
  - Place the gear selector at position **N (AUTO mode)**.
  - Press the brake pedal then the "**ECO OFF**" button.

If the HDi Diesel engine was on standby, it then restarts.  
If the HDi Diesel engine is running, its operation is maintained without time limit.

# Temporary puncture repair kit

This kit comprises a compressor and a sealant cartridge.  
It allows you to carry out a **temporary repair** to a tyre.  
This makes it possible to continue to the nearest garage.

- i** It can be used for repairing most punctures on the tread or shoulder of the tyre.  
The compressor can be used to check and adjust a tyre pressure.

## Access to the kit

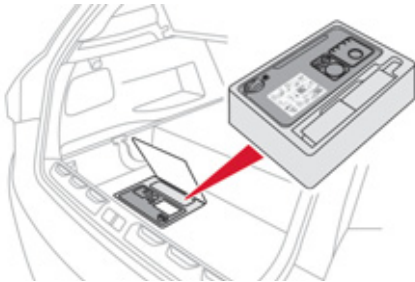

This kit is installed in the storage box, under the boot floor.

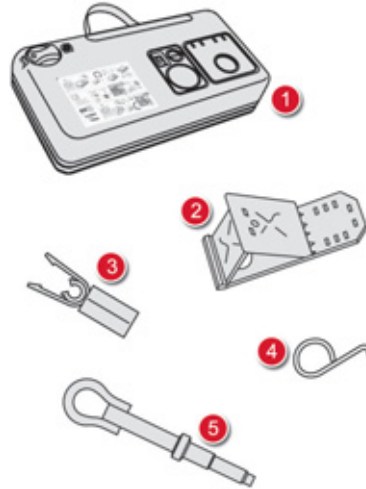

- i** For more information on the use of this temporary puncture repair kit, refer to the corresponding section in the handbook for the vehicle.

## List of tools

- 12 V compressor.  
Contains a sealant cartridge for the temporary repair of a tyre and can also be used for adjusting tyre pressures.
- Chock.  
For blocking the wheels of the vehicle.
- Wheel bolt cover remover.  
For removing the wheel bolt head protectors on alloy wheels.
- Wheel trim remover.  
For removing the wheel bolt finishers on alloy wheels.
- Removable towing eye.

- !** All of these tools are specific to your vehicle.  
Do not use them for other purposes.

## Recovery of the vehicle on a flat-bed

Never recover the vehicle by towing it with two or four wheels on the ground, as there is a risk of damage to the transmission.

However, if necessary because access to the vehicle is difficult, the vehicle can be moved a few dozen metres, at a speed of less than 6 mph (10 km/h).

Before doing any work, with the ignition on, press the brake pedal and place the gear selector at position **N**, then switch off the Hybrid4 system (**READY** lamp off).

Always call on professionals for recovery of the vehicle on a flat-bed lorry or trailer.

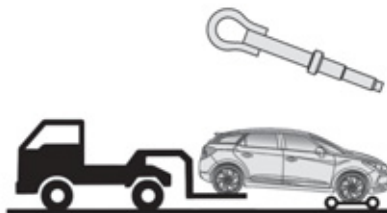

Use the towing eye **only** to pull the vehicle out or to lash it for recovery on a flat-bed lorry or trailer.

## Snow chains Recommendations

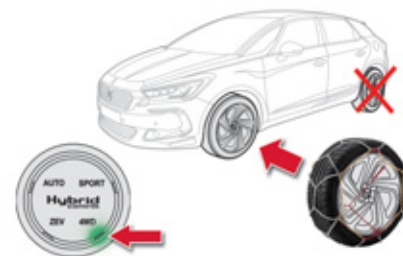

The use of snow chains is only authorised on the front wheels.

The mode selector must be in the **4WD** position.

 For information on the sizes compatible with the tyres on your vehicle and advice on use, refer to the corresponding section in the handbook for the vehicle.



# Electric motor and battery

<b>Electric motor</b>	-
Technology	Synchronous with permanent magnets
Max. power: EU standard (kW)*	27
Max. power speed (rpm)	2 000 to 7 500
Max. torque: EU standard (Nm)	200
Max. torque speed (rpm)	800 to 1 290
Efficiency (%)	80 to 90
<b>High voltage battery</b>	<b>Ni-MH</b> (Nickel Metal Hydride)
Voltage (V~)	200
Energy capacity (kWh / Ah)	1.1 / 5.5
Range (miles (km))	1.2 (2) (approximately)

\* The maximum power corresponds to the value type approved on a test bed, under conditions defined by European legislation (directive 1999/99/EC).

Range varies according to the ambient climatic conditions, the driving style and conditions, the use of vehicle systems and ageing of the battery.

# Diesel engine and gearbox

<b>Diesel engine</b>	<b>HDi 160</b>
<b>Gearbox</b>	<b>ETG6 electronic (6-speed)</b>
Cubic capacity (cc)	1 997
Bore x stroke (mm)	85 x 88
Max power: EU standard (kW)*	120
Max power engine speed (rpm)	3 850
Max torque: EU standard (Nm)	300
Max torque engine speed (rpm)	1 750
Fuel	Diesel
Catalytic converter	Yes
Particle filter	Yes
Engine oil capacity with filter replacement (in litres)	5.0

\* The maximum power corresponds to the type approved value on a test bed, under conditions defined by European legislation (directive 1999/99/EC).

## Weights and towed loads (in kg)

Version	Diesel Hybrid 4x4
Gearbox	ETG6 electronic (6-speed)
Model code: KF...	RHCM/1PS RHCM/PS
- Unladen weight	1 660
- Kerb weight*	1 735
- Gross vehicle weight (GVW)	2 265
- Gross train weight (GTW) on a 12% gradient	2 765
- Braked trailer (within GTW limit) on a 10% or 12% gradient	500
- Braked trailer** (with load transfer with the GTW limit)	800
- Unbraked trailer	500
- Recommended nose weight	75

\* The kerb weight is equal to the unladen weight + driver (75 kg).

\*\* The weight of the braked trailer can be increased, within the GTW limit, if the GVW of the towing vehicle is reduced by an equal amount; warning, towing using a lightly loaded towing vehicle may have an adverse effect on its road holding.

To make use of the 300 kg load transfer, the driver must be alone in the vehicle with no luggage in the vehicle.

The GTW and towed load values indicated are valid up to a maximum altitude of 1 000 metres; the towed load mentioned must be reduced by 10 % for each additional 1 000 metres of altitude.

The maximum authorised speed is reduced when towing (comply with the legislation in force in your country).

High ambient temperatures may result in a reduction in the performance of the vehicle to protect the engine; if the ambient temperature is above 37 °C, limit the towed load.

# Frequently asked questions

## 100% electric mode (zero emissions)

Question	Answer
<p>Why is it not always possible for me to select <b>ZEV</b> (Zero Emissions Vehicle) mode even though the battery seems well charged?</p>	<p>This situation is temporary. Certain conditions will occasionally prevent the change to <b>ZEV</b> mode, even if the battery has sufficient charge, such as, for example, very cold conditions, altitude, demisting, high demand for heating or air conditioning, regeneration of the particle filter (FAP).</p>
<p>Why do I sometimes see an alert message "<b>Electric mode not available: FAP regeneration in progress</b>"?</p>	<p>This is a message which indicates that regeneration of the particle filter (FAP) is in progress. This is a completely normal process that takes place every 240 or 300 miles (400 or 500 km) (or more frequently in prolonged urban use), as on a conventional HDi Diesel vehicle. In the case of a conventional HDi Diesel vehicle, this process is not generally noticed by the driver. On the other hand, in the case of Hybrid4 this phenomenon may be noticeable (in urban use) as temporarily the HDi engine will not stop and this message will be displayed at intervals while regeneration is in progress.</p>
<p>Why is it not possible for me to put the vehicle into <b>ZEV</b> mode, even though I had just been running electrically in <b>AUTO</b> mode?</p>	<p>The management of <b>ZEV</b> is different from <b>AUTO</b> mode. Changing to <b>ZEV</b> mode is only possible with a battery charge of at least 4 bars, in order to assure sufficient range. In <b>AUTO</b> mode, the system alone manages the conditions for changing temporarily to electric mode, for shorter periods and with a lower state of charge of the battery.</p>
<p>Why is the range in <b>ZEV</b> mode lower when going uphill?</p>	<p>The vehicle needs more energy when going uphill than when running on the level. So it is better to stay in <b>AUTO</b> mode, which will favour operation of the HDi Diesel engine.</p>
<p>Why is it that the system makes me come out of <b>ZEV</b> mode; it does not return to <b>ZEV</b> mode automatically when the conditions allow?</p>	<p>It is not intended to give preference to <b>ZEV</b> running at any cost, as it is not always the most economical mode. So the system returns automatically to <b>AUTO</b> mode.</p>



## Reducing consumption / Fuel

Question	Answer
How can I optimise my fuel consumption?	<p>Give preference to <b>AUTO</b> mode as it selects in the best way the "driving energy source" to use in order to reduce fuel consumption.</p> <p>You should also adapt your driving style to the characteristics of hybrid vehicles to get the best out of it, for example by taking your foot off the accelerator pedal rather than braking and by anticipating decelerations which allows the recovery of "free" energy for charging the battery (entering a built-up area, stop at traffic lights, stop at halt signs, ...).</p>
Why do I not manage to reduce my fuel consumption even though I often drive in <b>ZEV</b> (Zero Emissions Vehicle) mode?	<p>It is not <b>ZEV</b> mode but <b>AUTO</b> mode that is the most appropriate for reducing fuel consumption, as it selects the best "driving energy source".</p> <p><b>ZEV</b> mode (100% electric running) can reduce fuel consumption in some cases. However, recharging the traction battery has an energy cost.</p> <p>This is why we recommend using <b>AUTO</b> mode more often.</p>
Why does the fuel consumption histogram sometimes display consumption of 28 mpg (10 litres/100 km) in town?	<p>In traffic jams, the fuel consumption graph may temporarily display high values but, as the distance covered is low, this has very little impact on the average fuel consumption.</p> <p>In urban driving, your Hybrid4 will remain more efficient in terms of fuel consumption compared to a conventional vehicle.</p>
Why is my battery rarely fully charged?	<p>A partly charged battery is normal operation (4 to 5 bars on average in <b>AUTO</b> mode).</p> <p>This allows some capacity to be left free for the recovery of energy when decelerating.</p>
Why are there so many fuel alert messages when starting to use the reserve?	<p>To encourage you to refuel as soon as possible and to avoid losing the possibility of all electric running.</p>

## Air conditioning / Heating

Question	Answer
It seems to me that the vehicle runs less on electric when the heating or air conditioning is operating, is that right?	The demand for heating or air conditioning may require the starting of the HDi Diesel engine until the desired level of comfort is attained. Normal operation of the Hybrid4 system is simply put back. The period can be longer under very low or very high ambient temperatures.
It seems to me that when it is very hot and the air conditioning is working, the vehicle runs on electric for shorter periods. Is that right?	When it is hot, the periods when the HDi Diesel engine is put on standby and the vehicle runs on electric are necessarily restricted in order to limit the difference between the temperature in the vehicle and the level of comfort selected. In very hot weather, it is possible to press the " <b>ECO OFF</b> " button (which brings the vehicle out of <b>ZEV</b> mode and prevents electric running or the stopping of the engine) to give preference to temperature control (keeps the air conditioning running).

## Miscellaneous

Question	Answer
Is towing possible with my Hybrid4 vehicle?	For information on the towing ability of your Hybrid4 vehicle, refer to "Weights and towed loads" in the "Technical data" section. This allows a jet ski or two-wheeler on a trailer to be towed, for example. This limit is related to maintaining adequate cooling capacity for the HDi Diesel engine as well as the components of the Hybrid4 system that are also cooled by the engine's cooling system.
Why does engine braking seem so strong?	If the high voltage battery is not fully charged, the engine braking results mainly from the energy recovery by the electric motor. The power of this engine braking is higher than that of an internal combustion engine.

**A**

Advice on driving ..... 23  
 Air conditioning ..... 22, 25

**B**

Bag hook ..... 31  
 Back up starting ..... 18  
 Battery, 12 V ..... 5  
 Battery, high voltage ..... 5, 27-29, 39  
 Boot floor, removable ..... 31

**C**

Cable, high voltage ..... 28  
 Car wash ..... 36  
 Cooling, high voltage battery ..... 29

**D**

Defrosting ..... 25  
 Demisting ..... 25  
 Display screen, instrument panel ..... 8, 10, 13  
 Driving economically ..... 24

**E**

Eco-driving ..... 24  
 ECO OFF (switch) ..... 22  
 Electric running (ZEV) ..... 11, 20, 22, 24, 25  
 Electronic key ..... 15, 17, 18  
 Emergency switching off ..... 18  
 Energy flows ..... 10, 11  
 Energy recovery ..... 9, 11, 24

Engine compartment ..... 30  
 Engine, Diesel ..... 5, 19, 22, 25, 36, 40  
 Environment ..... 24

**F**

Filter, particle ..... 5, 26, 42  
 Fittings, boot ..... 31  
 Flat bed (recovery) ..... 38  
 Four-wheel drive (4WD) ..... 19, 21, 23, 38  
 Fuel consumption ..... 9, 12, 24

**G**

Gearbox, electronic ..... 5, 15, 23-25, 32  
 Gear selector, electronic gearbox ..... 32

**H**

Head-up display ..... 16  
 Heating ..... 22, 25  
 High voltage ..... 27, 28  
 Histogram, fuel consumption ..... 12

**I**

Ignition on ..... 17  
 Indicator, power ..... 9  
 Instrument panel ..... 8

**K**

Keyless Entry and Starting ..... 15, 17, 18  
 Key not recognised ..... 18  
 Kit, temporary puncture repair ..... 37

**M**

Mode selector ..... 2, 7, 19  
 Motor, electric ..... 5, 19, 39

**O**

Opening the bonnet ..... 30

**P**

Parcel shelf, rear ..... 31  
 Parking brake, electric ..... 15, 23, 36  
 Power indicator ..... 8, 9  
 Puncture ..... 37

## R

READY lamp .....	8, 9, 28, 30
Recovery of the vehicle .....	38
Regeneration of the particle filter .....	5, 26
Reset histogramme .....	14
Reset trip .....	13, 14
Retaining strap .....	31

## S

Selector, gear .....	32, 36
Snow chains .....	38
Speedometer .....	8
Starting the Hybrid4 system .....	15, 18
State of charge, battery .....	5, 10, 25, 27
Stop & Start .....	4, 6, 11, 27
Storage .....	31
Switching off the Hybrid4 system .....	15, 18

## T

Table of weights .....	41
Tables: of engine, motor .....	39, 40
Technical data .....	39-41
Tools .....	37
Touch screen .....	10, 12, 14
Towed loads .....	41
Towing eye .....	37
Triangle, warning .....	31
Trip computer .....	12-14
Tyres .....	37

## V

Ventilation, high voltage battery .....	29
---	----

## W

Washing (advice) .....	36
Weights .....	41





Labels are fitted in various areas of your vehicle. They carry safety warnings as well as vehicle identification information. Do not remove them: they form an integral part of your vehicle.

For any work on your vehicle, use a qualified workshop that has the technical information, competence and equipment required, which a CITROËN dealer is able to provide.

Automobiles CITROËN declares, by application of the provisions of the European regulation (Directive 2000/53) relating to End of Life Vehicles, that it achieves the objectives set by this regulation and that recycled materials are used in the manufacture of the products that it sells.

Reproduction or translation of all or part of this document is prohibited without written authorisation from Automobiles CITROËN.

**We draw your attention to the following points:**

- The fitting of electrical equipment or accessories not listed by CITROËN may cause faults and failures with the electrical system of your vehicle. Contact a CITROËN dealer for information on the range of recommended accessories.
- As a safety measure, access to the diagnostic socket, used for the vehicle's electronic systems, is reserved strictly for CITROËN dealers or qualified workshops, equipped with the special diagnostic tool required (risk of malfunctions of the vehicle's electronic systems that could cause breakdowns or serious accidents). The manufacturer cannot be held responsible if this advice is not followed.
- Any modification or adaptation not intended or authorised by Automobiles CITROËN or carried out without meeting the technical requirements defined by the manufacturer would lead to the suspension of the legal and contractual warranties.

Printed in the EU  
Anglais

08-15

4Dconcept  
Diadeis  
Interak

Automobiles CITROËN

Siège social : 6, rue Fructidor 75017 Paris - France

Tél. : +33 (0) 1 58 79 79 79 - [www.citroen.com](http://www.citroen.com)

Société anonyme au capital de 159 000 000 € - R.C.S. : 642 050 199 R.C.S. Paris - SIRET : 642 050 199 00990 - APE : 7010Z



DS AUTOMOBILES

SPIRIT OF  
AVANT-GARDE

15DS5H0041  
Anglais

[driveDS.com](http://driveDS.com)