

Ambassador

Mark II

O. H. V.

OPERATION MANUAL



PUBLISHED BY

HINDUSTAN MOTORS LTD.



**THE AMBASSADOR
MARK II**

GENERAL DATA

AMBASSADOR—MARK II

Engine	4 cylinder o. h. v.
Bore	2.875 in. (73.02 mm.)
Stroke	3.5 in. (88.9 mm.)
Cubic capacity	90.88 cu. in. (1489 c.c.)
Compression ratio	7.2 : 1
R.A.C. Rating	13.225 H.P.
Firing order	1, 3, 4, 2
Tappet clearance015 in. (.38 mm.) (hot)
Sparking plugs	MICOBOSCH, 14 mm. H-W 145T2 or KLG FE-50
Sparking plug gap025 in. (.64 mm.)
Contact breaker gap014 to .016 in. (.36 to .40 mm.)
Carburettor	S.U. semi-downdraught. 1½ in.
Rear axle ratio	4.875 : 1 (8/39)
Overall gear ratios :—			
1st	18.559 : 1
2nd	10.983 : 1
3rd	7.342 : 1
4th	4.875 : 1
Reverse	18.559 : 1
Fuel tank	12 gallons (54 litres)
Engine sump	4.54 litres [8 imp. pints (9.6 U.S. pints)]
Gear box	1.14 litres (2 pints)
Rear axle	1.14 litres (2 pints)
Water	8 litres (14 pints)
Tyre (5.50/5.90—15)		{	Front—24 lb./sq. in. (1.7 kg./cm ²)
Normal pressure (2 persons)		{	Rear—24 lb./sq. in. (1.7 kg./cm ²)

When additional passengers and luggage are carried, the pressure in the rear tyres should be increased in accordance with the load up to a maximum pressure of 28 lb./sq. in. (1.97 kg./cm²)

DIMENSIONS :

Track (front)	53½ in. (135.9 cm.)
Track (rear)	53 in. (134.6 cm.)
Turning circle—Right-hand lock	35 ft. 6½ in. (10.83 m.m.)
Left-hand lock	35 ft. 3 in. (10.74 m.m.)
Toe-in	3/32 in. (2.4 m.m.)
Wheelbase	97 in. (2.464 m.)
Length	171 in. (4.343 m.)
Width	65 in. (1.651 m.)
Height	63 in. (1.600 m.)
Ground clearance	6½ in. (15.9 cm.)
Unladen weight	1162 kg. (2563 lbs.)

CONTROLS

GEAR LEVER

The gear change lever positions are clearly shown below. The normal position in neutral is between the third and fourth gear positions. To engage the reverse gear, push the lever downwards in the neutral position to the limit of its travel and then move it rearwards.

Synchromesh engagement is provided on second, third and fourth gears.

PEDALS

The left-hand pedal operates the clutch, the centre pedal operates the brakes, and right-hand pedal operates the accelerator.

Do not allow the foot to rest on the clutch pedal while driving or excessive wear of the operating mechanism will result.

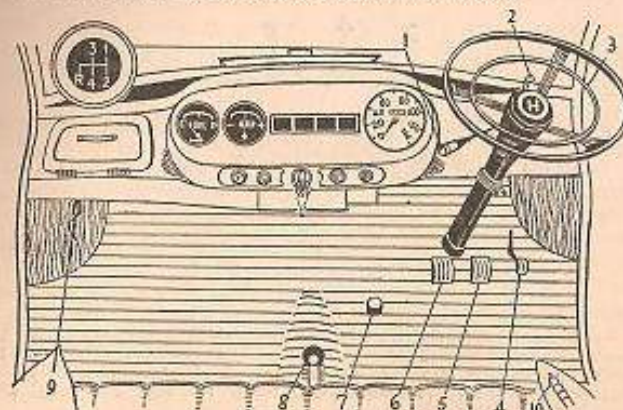

Fig. 2

1. Gear Lever 2. Direction Indicator Control 3. Horn Ring (Press) 4. Accelerator Pedal 5. Brake Pedal 6. Clutch Pedal 7. Head Lamp Dip. Switch (Press) 8. Seat Adjustment (Pull to release) 9. Bonnet Release (Pull) 10. Hand-brake (Pull on).

HAND BRAKE

The hand brake is located next to the driving seat. A "thumb-operated" ratchet release is incorporated in the handle. Pulling the handle upwards operates the rear wheel brake-shoes mechanically.

Brake release is achieved by pulling on the lever to take the load and then pressing the ratchet release. The hand brake is automatically adjusted when adjustment is made to the foot brake.

INSTRUMENTS AND SWITCHES

HEAD LAMP SWITCH

The foot-operated headlamp beam dipping switch is located in the centre of the toe-board. It is of the single-acting repeating type, lowering the beams on one application and raising them on the next. The headlamp beam warning light glows when the beams are in the raised position.

DIRECTION INDICATOR SWITCH (FLASHING)

The flashing direction indicators are operated by the small centrally situated lever, provided the ignition is switched on.

The switch is self-cancelling and operates the light on the side to which it is turned. If only a slight turn is made it may be necessary to return the switch manually.

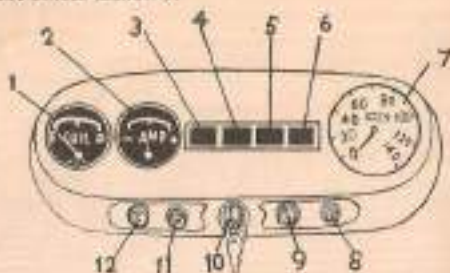

Fig. 3

1. Fuel Gauge 2. Ammeter 3. Lens Warning Light—Oil Pressure (Amber) 4. Lens Warning Light—Main Beams (Blue) 5. Lens Warning Light—Flasher (Green) 6. Lens Warning Light—Ignition (Red) 7. Speedometer 8. Panel Light Switch 9. Side Top Head Lamp—Switch 10. Ignition—Start Switch 11. Wiper Switch 12. Choke Control Switch.

HORN

The horns are operated by pressing the inner ring surrounding the steering wheel hub.

IGNITION—START SWITCH

The combined ignition-start switch is located in the centre of the control panel (See Fig. 3 item 10) and is operated by a removal key which also locks the driver's door and luggage compartment lid. The first movement of the switch switches on ignition circuit (indicated by the red warning light—see fig. 3 item 6). Further rotation of the switch against the pressure of a spring operates the starter. On releas-

INSTRUMENTS AND SWITCHES

ing the switch, it automatically returns to the starting position. The switch should be released to the starting position as soon as the engine starts running.

LIGHTING SWITCH (MARKED 'L')

On the right hand side of the control panel, next to the ignition-start switch is located the lighting switch (See Fig. 3 item 9). It is two position pull-push switch. Pulling out the switch to its first position switches on the side and tail lamps; pulling the switch further out lights on the head lamps. The blue beam warning light glows when the beams are in raised position.

PANEL LIGHT SWITCH (MARKED 'P')

The panel light switch is located at the extreme right of the control panel (See Fig. 3 item 8) and is pull-push type. The light is switched on when the knob is pulled provided the side lamps are switched on.

WINDSHIELD WIPER SWITCH (MARKED 'W')

The two windshield blades are operated by a pull-push switch marked 'W' and is located on the left hand side next to the ignition-start switch (See Fig. 3 item 11). Pull the switch knob out to bring both the blades in operation. Parking of the blades is automatic when the switch is pushed back to the 'off' position.

CHOKE OR MIXTURE CONTROL (MARKED 'C')

To enrich the mixture and assist starting when the engine is cold, pull the control knob marked 'C' located at the extreme left on the control panel (See Fig. 3 item 12).

Excessive use of the choke results in liquid petrol being drawn into the engine. This will cause excessive wear by washing the lubricant from the cylinder walls and deluting the oil in the sump. The choke knob should be pushed back to the 'off' position as soon as possible after the engine starts firing smoothly.

OIL PRESSURE WARNING LIGHT (AMBER)

This is the amber lamp (See Fig. 3 item 3) which glows when the ignition switch is switched on and engine is not running. It should go out when the engine is started and should remain out all the time the engine is running. Should this light continue to remain 'on' while engine running or does not light when the ignition is in the 'on' position before starting the engine, your dealer should be contacted immediately for necessary correction.

INSTRUMENTS AND SWITCHES

Warning: The lamp is operated by oil pressure through an automatic switch located in the engine crankcase and will, therefore, light up as soon as the oil pressure falls below the safety limit.

MAIN BEAM WARNING LIGHTS (BLUE)

The light, located second from left (See Fig. 3 item 4), glows 'blue' when the head lamps are on and the beams are in the raised position in order to remind the driver to dip for approaching traffic.

FLASHER WARNING LIGHT (GREEN)

This is the small 'green' lamp located next to the blue main beam warning lamp (See Fig. 3 item 5). Whenever the flashing direction indicator lamps are operated by moving the small centrally located lever on the steering hub (See Fig. 2 item 2), the flasher warning lamp also lights on and serves as a warning, should any failure occur in the system.

IGNITION WARNING LIGHT (RED)

This is the small 'red' lamp located at the extreme right hand side and next to the green flasher warning light (See Fig. 3 item 6). Whenever the ignition is switched on, the lamp lights up. It should go out as soon as the engine speed is increased. Should it fail to do so ascertain that dynamo belt is not broken or loose. If the belt is undamaged and is not loose, the dynamo is not charging. Electric circuit should be examined for location and rectification of the fault.

This red lamp also serves as a reminder not to leave the ignition switched on when the engine is not running.

SPEEDOMETER

The speedometer is situated on the right-hand side of the instrument panel (See Fig. 3 item 7) and gives indication of the total distance travelled.

INTERIOR LIGHT

A switch for the interior light is provided on the right-hand door pillar. An automatic switch is also fitted on each front door pillar. With both front doors closed the lamp may be switched on or off by operating the switch.

The act of opening either front door will switch on the lamp and closing the door will extinguish it.

WARNING LAMPS AND PANNEL BULBS

To change the panel and warning light bulbs unscrew the four fixing

INSTRUMENTS AND SWITCHES

screws to remove the cover from the combined ashtray aperture on the dash-board. The bulbs are then accessible from the back of the panel.

The bulb holders are pulled away from the locations to bulbs to be removed and replaced.

Note—On earlier model cars, two types of instruments were fitted as per Fig. No. 4 and 5 furnished below:

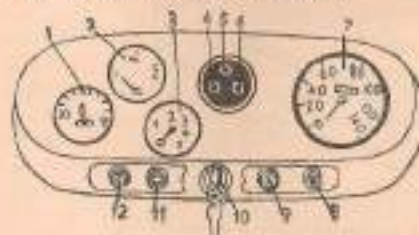

Fig. 4

1. Ammeter
2. Fuel Gauge
3. Oil Gauge
4. Direction Indicator Warning Light
5. Headlamp Beam Warning Light
6. Ignition Warning Light
7. Speedometer
8. Starter Switch
9. Power Light Switch
10. Ignition and Headlamp Switch
11. Wiper Switch
12. Mixture Control Switch

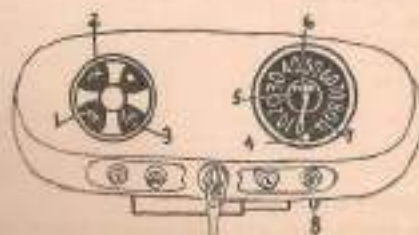

Fig. 5

1. Oil Gauge
2. Ammeter
3. Fuel Gauge
4. Head Lamp Beam Warning Light
5. Trip Meter
6. Total Mileage Indicator Meter
7. Ignition Warning Light

INSTRUMENTS AND SWITCHES

Warning: The lamp is operated by oil pressure through an automatic switch located in the engine crankcase and will, therefore, light up as soon as the oil pressure falls below the safety limit.

MAIN BEAM WARNING LIGHTS (BLUE)

The light, located second from left (See Fig. 3 item 4), glows 'blue' when the head lamps are on and the beams are in the raised position in order to remind the driver to dip for approaching traffic.

FLASHER WARNING LIGHT (GREEN)

This is the small 'green' lamp located next to the blue main beam warning lamp (See Fig. 3 item 5). Whenever the flashing direction indicator lamps are operated by moving the small centrally located lever on the steering hub (See Fig. 2 item 2), the flasher warning lamp also lights on and serves as a warning, should any failure occur in the system.

IGNITION WARNING LIGHT (RED)

This is the small 'red' lamp located at the extreme right hand side and next to the green flasher warning light (See Fig. 3 item 6). Whenever the ignition is switched on, the lamp lights up. It should go out as soon as the engine speed is increased. Should it fail to do so ascertain that dynamo belt is not broken or loose. If the belt is undamaged and is not loose, the dynamo is not charging. Electric circuit should be examined for location and rectification of the fault.

This red lamp also serves as a reminder not to leave the ignition switched on when the engine is not running.

SPEEDOMETER

The speedometer is situated on the right-hand side of the instrument panel (See Fig. 3 item 7) and gives indication of the total distance travelled.

INTERIOR LIGHT

A switch for the interior light is provided on the right-hand door pillar. An automatic switch is also fitted on each front door pillar. With both front doors closed the lamp may be switched on or off by operating the switch.

The act of opening either front door will switch on the lamp and closing the door will extinguish it.

WARNING LAMPS AND PANNEL BULBS

To change the panel and warning light bulbs unscrew the four fixing

INSTRUMENTS AND SWITCHES

screws to remove the cover from the combined ashtray aperture on the dash-board. The bulbs are then accessible from the back of the panel.

The bulb holders are pulled away from the locations to bulbs to be removed and replaced.

Note—On earlier model cars, two types of instruments were fitted as per Fig. No. 4 and 5 furnished below:

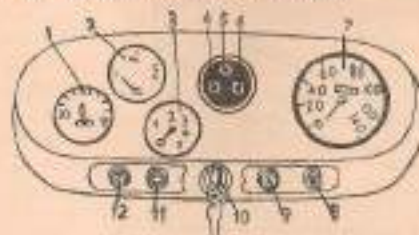

Fig. 4

1. Ammeter
2. Fuel Gauge
3. Oil Gauge
4. Direction Indicator Warning Light
5. Headlamp Beam Warning Light
6. Ignition Warning Light
7. Speedometer
8. Starter Switch
9. Power Light Switch
10. Ignition and Headlamp Switch
11. Wiper Switch
12. Misture Control Switch

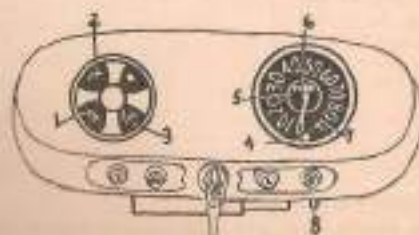

Fig. 5

1. Oil Gauge
2. Ammeter
3. Fuel Gauge
4. Head Lamp Beam Warning Light
5. Trip Meter
6. Total Mileage Indicator Meter
7. Ignition Warning Light

DOOR LOCKS

DOOR HANDLES AND LOCKS

The driver's door is locked by means of the Ignition key. The two rear doors and the door on the passenger's side are locked by pushing the interior handle forward.



Fig. 6
The ignition key is used to lock the driver's door

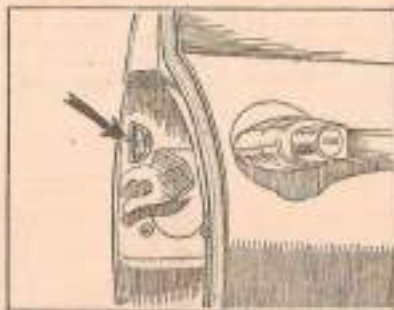

Fig. 7
The arrow indicates the small lever which should be pushed downwards to prevent the doors from being opened from the inside when carrying children

CHILDREN'S SAFETY DOOR LOCKS

In addition to the locks provided for use against unlawful entry from the outside, a children's safety locking device is fitted which prevents the doors from being opened from the inside by children.

Situated in the edge of each door, adjacent to the latch cam, will be found a small lever (See Fig. 7). When children are carried, the small lever should be moved downwards prior to closing the doors. The doors can then only be opened from the outside.

This device need not be used for normal locking and is for use only when the safety of children during journeys is desired.

BONNET LOCKS

WINDOW CONTROLS

In addition to the normal winding window, each front door is provided with a hinged ventilator panel which is latched, when in the fully closed position, by a small finger lever.

The ventilating panels are frictionally held in any desired open position.

RELEASING THE BONNET LOCK

Release the bonnet catch from inside the car by a gentle pull on the control knob which is to be found under the fascia panel on the extreme left-hand side. (See Fig. 8)



Fig. 8
The bonnet is released by pulling the loop handle on the extreme left below the fascia panel



Fig. 9
The bonnet safety catch is released by inserting a finger below the partly raised bonnet and raising the catch lever

RELEASING THE BONNET SAFETY HOOK

Release the safety hook by raising the lever up which can be felt just beneath the bonnet motif. Raise the bonnet lid, release the bonnet prop, and place its end into the bonnet latch hole on top of the radiator mask. Make sure the prop is securely engaged before working under the bonnet.

BONNET LOCKS & SEAT ADJUSTMENT

CLOSING THE BONNET

Raise the bonnet until the prop is clear, return it to its clip, and lower the bonnet to engage the safety hook. Apply double hand pressure to the bonnet front to force the bonnet down into the fully closed position. The bonnet lock will be heard to spring into engagement.

It is important to keep the bonnet lock properly oiled.

SEAT ADJUSTMENT

SEAT ADJUSTMENT

The front seat is adjustable and is secured in position by a spring-loaded locking pin which engages a series of locating holes in the guide tube in the centre of the floor. (See Fig. 10)

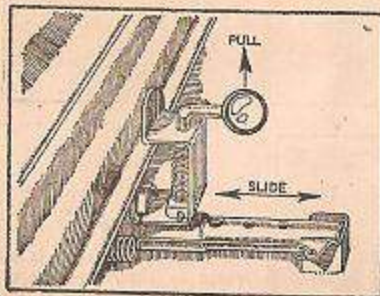

Fig. 10
Pull the locking pin knob upwards to release the front seat for adjustment

STARTING HANDLE

When it is required to use the starting handle, insert the shaft through the hole in the bumper, engaging the dowels with the dog on the engine.

When turning the engine it is important to keep the thumb of your hand on the same side of the handle as the palm for safety in case of backfire.

FUEL FILLER, SPARE WHEEL AND TOOLS

FILLING UP WITH FUEL

The fuel tank filler is located on the right-hand side above the rear wing and the cap is released by lifting the tab (See Fig. 11). Press the cap downwards to seal the tank.

The tank capacity is 12 gallons (54 litres).

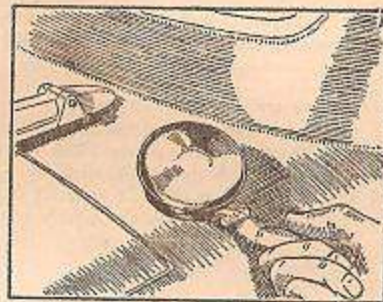

Fig. 11
The fuel tank filler is located on the right-hand side above the rear wing

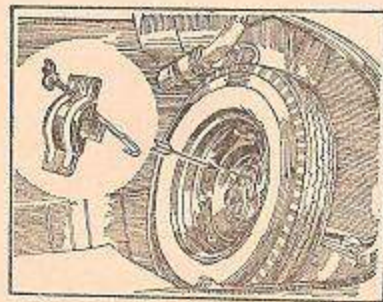

Fig. 12
To remove the spare wheel unscrew the wing nut and take off the clamp plate

SPARE WHEEL, JACK AND TOOL LOCATION

The spare wheel is carried in the boot and is secured in position by a wing nut and clamp plate, which must be removed before the wheel can be withdrawn (See Fig. 12). Accessories are supplied by the dealer to you.

RUNNING INSTRUCTIONS

RUNNING IN

For the first 200 miles (320 km.) do not exceed the speeds of—

- 35 m.p.h. (56 Km.p.h.) in top gear.
- 26 m.p.h. (42 Km.p.h.) in third gear.
- 15 m.p.h. (24 Km.p.h.) in second gear.
- 10 m.p.h. (16 Km.p.h.) in first gear.

The engine speed should then only be increased gradually and progressively until at least 1,000 miles (1600 km.) have been covered.

WARMING UP

It is extremely bad practice to allow the engine to warm up from cold by letting it idle slowly. The correct procedure is to let the engine turn over fairly fast (approximately 1,000 r.p.m., corresponding to a speed of 15 m.p.h. [24 km.p.h.] in top gear) so that it attains its correct working temperature as quickly as possible.

STARTING UP

Before starting the engine, make sure that the gear lever is in the neutral position. When starting from cold, pull out the choke or mixture control (marked 'C'). Switch on the ignition and pull the starter button (marked 'S'). The engine will be set in motion and after a second or two should start up, when the button must immediately be released. Should the engine fail to start first time, allow it to come to rest before operating the control again.

With a new car or in cold weather, the engine should first be freed by turning it with the starting handle, with the ignition switched off, before using the starter.

Gradually return the mixture control knob to the 'off' position as quickly as the warming engine will allow.

COOLING SYSTEM

FILLING THE COOLING SYSTEM

The radiator should be filled to approximately $\frac{1}{2}$ in. (13 mm.) below the bottom of the filler neck.

Unscrew the filler cap slowly if it is being removed while the engine is hot.

The filler cap is retained by a bayonet catch with a graduated cam which permits release of internal pressure prior to removal. A lobe on the end of the cam guards against accidental release of the cap before the internal pressure is relieved. Protect your hand against escaping steam.

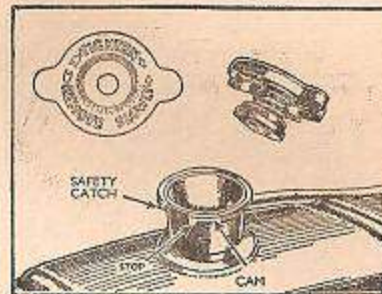

Fig. 13

The radiator filler cap removed to show the safety catch and stop

COLD WEATHER PRECAUTIONS

Water upon freezing expands, with the result that there is a very considerable risk of bursting either the radiator or the cylinder block by the pressure generated. As a precautionary measure when frost is anticipated an anti-freezing solution must be used in the radiator.

We recommend owners to use non-erosive anti-freeze in order to protect the cooling system during frosty weather and reduce corrosion to a minimum.

The correct quantities of anti-freeze for different degrees of frost resistance are :

Down to 7°F. (—14°C.)	Down to 0°F. (—18°C.)
15% solution	20% solution
Quantity : 1.25 litres (2½ pints)	Quantity : 1.7 litres (3 pints)

First decide what degree of frost protection is required before adding the anti-freeze to the radiator. If temperatures below 0°F. (—18°C) are likely to be encountered, a mixture of at least 25 per cent, of anti-freeze must be used. Consult authorised H.M. Dealer.

COOLING SYSTEM

Before introducing anti-freeze mixture to the radiator it is advisable to clean out the cooling system thoroughly by swilling out the passage with a hose inserted in the filler cap, keeping the two drain taps open. Only top up when the cooling system is at its normal running temperature, in order to avoid losing anti-freeze due to expansion.

Make sure that the cooling system is watertight and examine all joints, replacing any defective rubber hose with new.

DRAINING THE COOLING SYSTEM

Two taps are provided to ensure that the cooling system is completely drained.

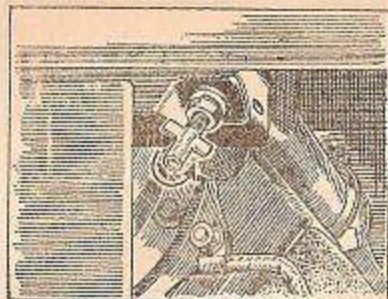
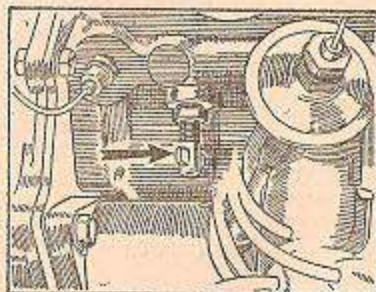

Fig. 14
Access to the radiator drain tap is gained from below the bumper on the right hand side. Turn the tap anti-clockwise to open it.

Fig. 15
The drain tap for the cylinder block is located on the right-hand side of the block at the rear end. Turn anti-clockwise to open the tap.



The radiator drain bolt on the left-hand side of the radiator bottom tank is easily accessible beneath the front bumper.

The cylinder block drain bolt is located on the right-hand side of the engine above the starter. The radiator and cylinder block drain bolts must both be opened to drain the system completely.

IGNITION EQUIPMENT

IGNITION ADJUSTMENT

Adjustment is provided for the ignition point to enable the best setting to be attained to suit varying fuels.

This consists of a knurled nut giving micrometer adjustment for the firing point.

Turning the nut clockwise retards the ignition. Turning it anti-clockwise advances the ignition.

The barrel of the screwed spindle has graduations to indicate the settings.

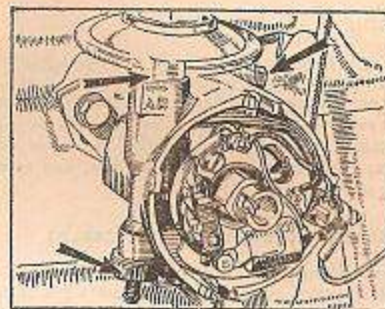

Fig. 16
The two arrows on the left indicate therein adjusting screw and markings, the arrow on the right indicates the distributor clamping nut.

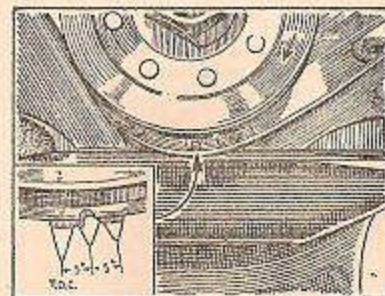

Fig. 17
The groove in the crankshaft pulley and the pointers to assist correct timing.

IGNITION SETTING

The normal ignition setting is with the spark taking place 6° B.T.D.C. The ignition point can be reset by loosening the pinch-bolt for the pinchclip at the base of the distributor body and rotating the body to the desired extent. Do not, however, disturb the pinch-clip unless absolutely necessary.

IGNITION EQUIPMENT

The range of adjustment provided by the micrometer adjuster is normally ample.

TOP DEAD CENTRE

The crankshaft pulley has a small groove which coincides with the long pointer on the timing chain case when the crankshaft is in the dead centre position for Nos. 1 and 4 cylinders. The other two pointers are 5° and 10° B.T.D.C.

COIL

The coil requires no attention beyond keeping its exterior clean, particularly between the terminals, and occasionally checking that the terminal connections are quite tight. If the high-tension cable needs renewal it should be replaced by 7-mm. rubber-covered ignition cable. Bare the end of the cable for $\frac{1}{4}$ in. (6 mm.). pass it through its moulded terminal and washer, and spread out the stands to ensure good contact.

RENEWING HIGH TENSION CABLES

The high-tension cables connecting the distributor to the sparking plugs may, after long use, show signs of perishing. They must then be replaced by 7-mm. rubber-covered ignition cable.

Unscrew the cable-securing screws to release the cable.

The new cables are cut to length, pushed well home in the distributor cover and pierced by replacing the cable-securing screws.

ELECTRICAL EQUIPMENTS

FUSES

Fuse connecting 'A1' and 'A2'. This fuse protects the accessories which are connected so that they operate irrespective of whether the ignition is on or off.

Fuse connecting 'A3' and 'A4'. This fuse protects the accessories which are connected so that they operate only when the ignition is switched on (stop lamp, direction indicators, etc.).

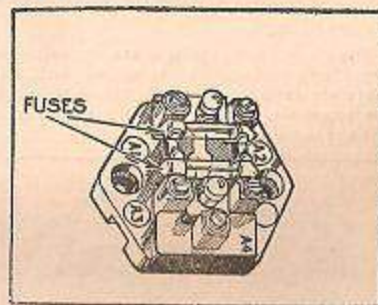

Fig. 18
The fuses are carried in the separate fuse block mounted on the bulkhead

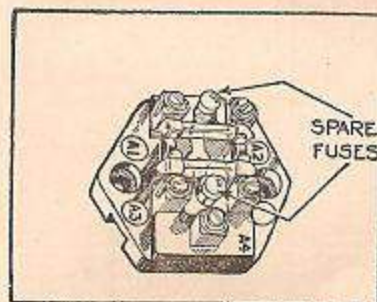

Fig. 19
Two spare fuses are housed in holders on the fusebox

BLOWN FUSES

The units which are protected by the fuse can readily be identified on the wiring diagram. A blown fuse is indicated by the failure of all the units protected by it, and is confirmed by examination of the fuse when withdrawn. Before renewing a blown fuse, inspect the wiring of the units that have failed for evidence for short circuit or other fault. Remedy the cause of the trouble before fitting a new fuse.

ELECTRICAL EQUIPMENTS

SPARE FUSES

Spare fuses are provided and it is important to use only 35 amps rating fuses. The fusing value is marked on a coloured paper slip inside the glass tube of the fuse. If the new fuse blows immediately and the cause of trouble cannot be found, have the equipment examined by an authorised HM dealer.

Note :—Battery should always be disconnected when any work is undertaken on dynamo, self-starter, ignition coil, flasher unit, etc.

CONTROL BOX

The cut-out and regulator are accurately set before leaving the Works and they must not be tampered with. The cover protecting them is therefore sealed. The fuses are mounted on a separate fuse unit and are accessible without removing the cover protecting the regulator and cut-out units.

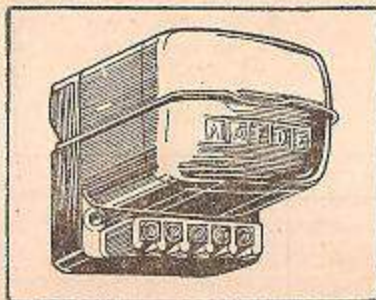

Fig. 20
The cut-out and regulator require no attention and should never be tampered with

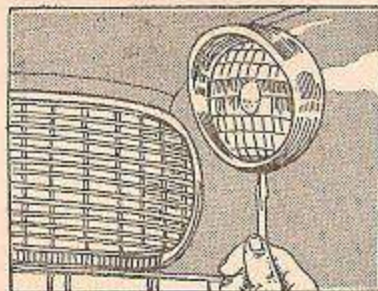

Fig. 21
The head lamp rim-retaining screw

HEAD LAMPS

To remove the light unit for bulb replacement, unscrew the securing

ELECTRICAL EQUIPMENT

screw at the bottom of the lamp rim and lift off the rim (See Fig. 21). Remove the dust-excluding rubber, which will reveal three spring-loaded screws. Press the light unit inwards against the tension of the springs and turn it in an anti-clockwise direction until the heads of the screws can pass through the enlarged ends of the keyhole slots in the rim.

REPLACING BULBS

Withdrawal of the light unit gives immediate access to the bulb holder for replacement.

Twist the back shell anti-clockwise and pull it off. The main bulb can then be withdrawn from its holder. Fit the replacement bulb in the holder, with the slot in its disc in engagement with the projection in the holder. Engage the projections on the back shell with the holder slots, press on and twist to the right until its catch engages (See Fig. 22).

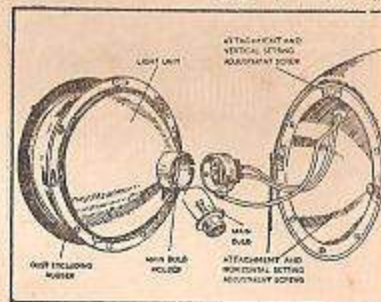

Fig. 22
The lamp unit removed to show the bulb holder and back shell

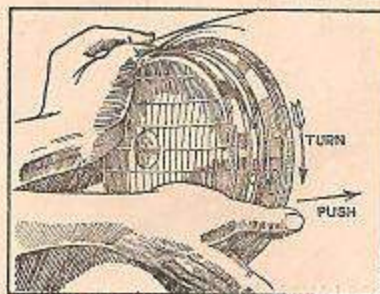

Fig. 23
Replacing the lamp unit

REPLACING THE LIGHT UNIT AND LAMP FRONT

Position the light unit so that the heads of the adjusting screws pass through the slotted holes in the flange. Press the unit inwards and

ELECTRICAL EQUIPMENT

turn it in a clockwise direction as far as it will go. Replace the dust-excluding rubber and refit the front rim (See Fig. 23).

SETTING HEAD LAMPS

The lamps should be set so that the main driving beams are parallel with the road surface or in accordance with local regulations. If adjustment is required, remove the rim as described on page 20.

Vertical adjustment is made by turning the screw at the top of the lamp. Horizontal adjustment can be altered by using the adjustment screws on each side of the light unit (See Fig. 24).

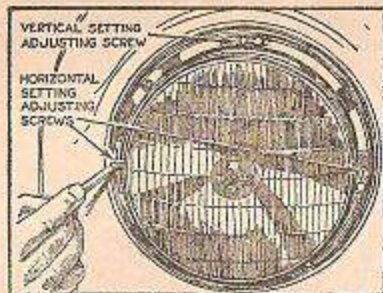
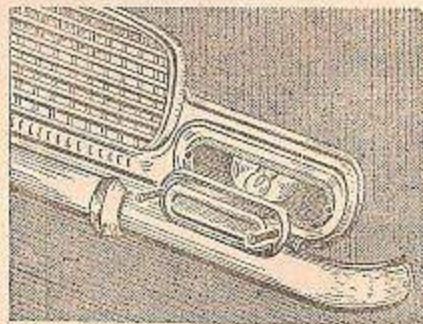

Fig. 24
The method of setting the headlamp beams

Fig. 25
Front sidelamp glass retaining screws are removed to show the bulb and holder



SIDE AND FLASHING INDICATOR LAMPS—FRONT

Access to the side and flashing lamp bulb for replacement is obtained by removing the lamp glass which are retained in position by two screws and with a rubber sealing gasket (See Fig. 23).

ELECTRICAL EQUIPMENT

STOP, TAIL AND FLASHING INDICATOR LAMPS

The flashing indicator bulb is fitted in the top compartment. Stop and the tail lamp bulb is fitted beneath the flashing indicator bulb. The stop and tail lamp bulb is of the double filament type, giving a marked increase in illumination on brake application to provide a stop warning. The bulb also has offset locating pins to ensure correct replacement. (See page 25 for replacement bulbs.)

To gain access to the bulbs, remove the two screws securing the lamp unit rim to the body and remove the rim (See Fig. 26).

Either lamp glass may be removed by first pushing inwards and then turning the glass in an anti-clockwise direction to free it from the securing lobes.

Fig. 26
Remove the two rim retaining screws to gain access to the lamps; the glasses are then removed by pushing inwards and turning them anti-clockwise

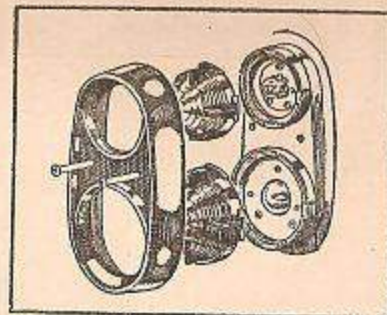

ELECTRICAL EQUIPMENT

NUMBER PLATE LAMPS

The number plate is illuminated by a separate lamp with a single bulb of 12-volt 6-watt rating. The domed cover is removed for bulb replacement by unscrewing the slotted screw (See Fig. 27). The bulb is of the miniature bayonett type and is easily removed and replaced.

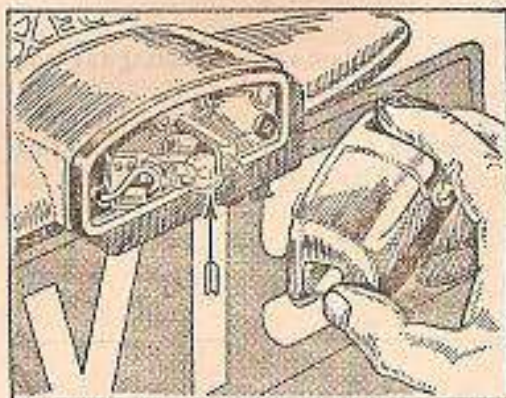

Fig. 27
Slacken the central screw and remove the cover to obtain access to the bulb

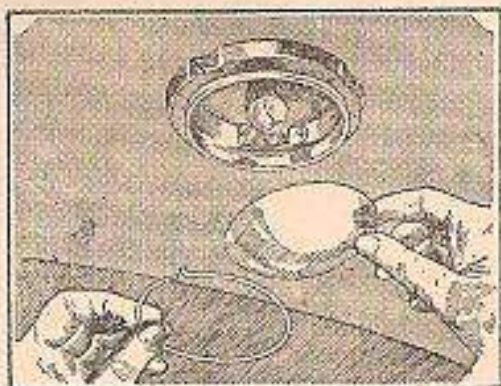

Fig. 28
A wire circlip retains the roof lamp glass

ROOF LAMP BULB REPLACEMENT

The roof lamp bulb can be replaced by removing the glass which is retained by a wire circlip (See Fig. 28).

ELECTRICAL EQUIPMENT

STARTER

The starter motor is mounted on the right-hand side of the engine on the flywheel housing. It requires no lubrication between overhaul periods.

In the event of the starter pinion becoming jammed in mesh with the flywheel, it can usually be freed by turning the starter armature by means of a spanner applied to the shaft extension at the commutator end. This is accessible by removing the small cap (See Fig. 29).

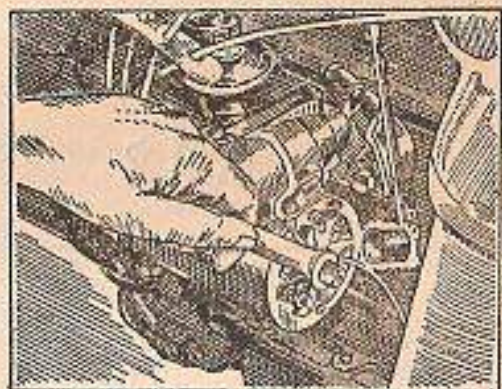

Fig. 29
A jammed starter pinion may be freed by turning armature shaft by means of a spanner

REPLACEMENT BULBS

				Volts	Watts
Headlamps	12	42/36
Pilot Lamps	12	6
Stop Lamps	12	18
Tail Lamp	12	6
Number Plate Illumination Lamp	12	6
Roof lamp	12	6
Ignition warning light	12	2.2
Headlamp beam-warning light	12	2.2
Panel, side and tail warning lights	12	2.2

WHEELS AND TYRES

JACK OPERATION

Apply the hand brake and remove the rubber plug from the socket which is welded to the chassis on either side beneath the centre door pillar. Insert the arm of the jack and raise the side of the car until the wheels are almost clear of the ground.

As the car swings over when one side is raised, the top of the jack should lean slightly outwards at the start of the lift, so that it is vertical when the wheels are raised clear of the ground. (See Fig. 30)

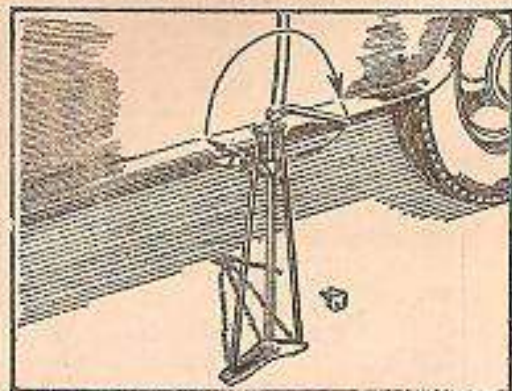
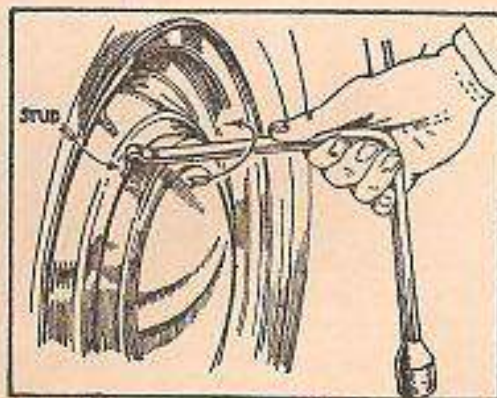

Fig. 30
The jack should be positioned leaning out slightly at the top

Fig. 31

Use the special attachment on the end of the wheel nut spanner to remove the hub caps.



REMOVING THE WHEEL DISC

Remove the wheel disc by inserting the tyre lever in the recess provided in the road wheel and levering off the hub cover, using a sideways motion of the lever and not a radial one (See Fig. 31). A radial movement of the lever will open out the rim of the disc. To refit the hub disc, the rim should be placed over two of the buttons on the wheel centre and the outer face given a sharp blow with the fist over the third button.

WHEELS AND TYRES

REMOVING THE WHEELS

Slacken the five nuts securing the road wheels to the hub. The wheel nuts have right-hand threads i.e. turn clock-wise to tighten and anti-clockwise to remove. Raise the car to lift the tyre clear of the ground and remove the nuts. Lift the road wheel from the studs.

Reverse this procedure when replacing the road wheel. Ensure that the securing nuts are tight. In case of cars fitted with A.P.I. brakes, also ensure that the brake adjuster seals are in position with the adjustment hole in the wheel opposite the hole in the brake-drum. For details of braking system, please refer to Page No. 48 to 50.

TYRE PRESSURES

The recommended tyre pressures are given on Page No. 4

Maintain the correct inflation pressures by checking with an accurate tyre gauge at least once a week. Correct when necessary.

Any unusual pressure loss should be investigated. Under-inflation causes rapid wear, and even more serious is the possible damage to the cords of the fabric owing to excessive bending or flexing of the cover walls.

TYRE VALVES

See that the valve caps are screwed down firmly by hand.

The reliability of a valve depends upon the proper functioning of its interior. It may be tested for air tightness by rotating the wheel until the valve is at the top and inserting its end in a container full of water. If bubbles appear, the seatings is faulty and should be renewed. When valve caps are removed, do not place them on a dusty road surface.

REMOVING TYRES

Inextensible wires are incorporated in the edges of tyres. Do not attempt to stretch the edges of the tyre cover over the rim. Force is entirely unnecessary and dangerous, as it merely tends to damage the cover edges.

WHEELS AND TYRES

Remove valve inner core to completely deflate the tyre and push both cover edges into the base of the rim (See Fig. 32).

Lever the cover edge over the rim edge (See Fig. 33).

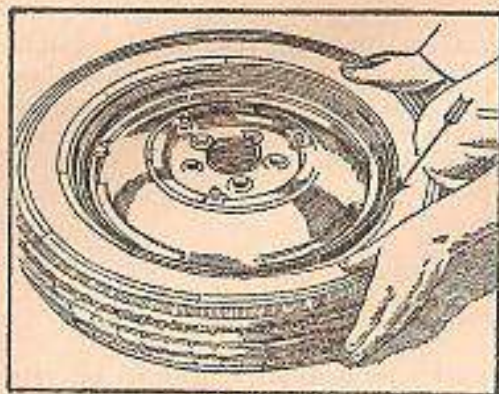

Fig. 32
The cover beads should be pushed into the wheel base of the rim

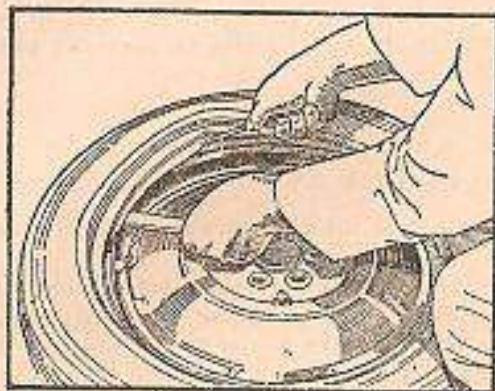

Fig. 33
The cover edge can then be levered over the rim to remove it, or replace it, as required

TYRE REPLACEMENT

A similar technique has to be employed when replacing the tyre. First fit the tyre into the rim and then use a tourniquet to spread the tyre beads to touch the wheel rim edges as the tyre beads form the air seals in the wheel rim.

Great care must be taken not to damage the bead. Use tyre levers which are in good condition.

WHEELS AND TYRES

REPAIRING TUBELESS TYRES

When convenient, the penetrating object should be removed and the tyre repaired. Small diameter penetrations can be repaired with the tyre manufacturer's plugging kit without removing the tyre. More extensive damage requires the removal of the tyre and vulcanizing.

Fig. 34
A section through a tubeless showing
A. Air-retaining liner
B. Rubber air seal
C. Rubber sealed valve

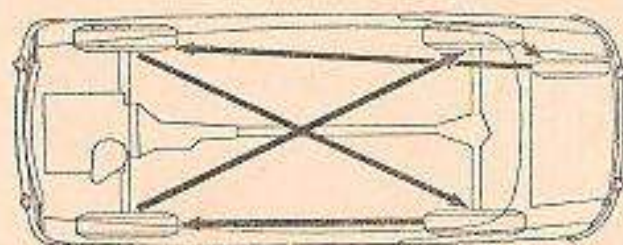
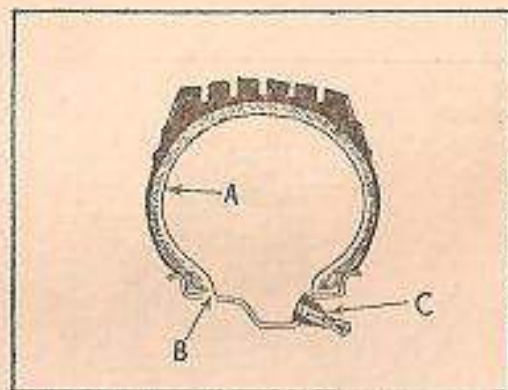

Fig. 35
Changing position of tyres

CHANGING POSITION OF TYRES

To obtain the best tyre mileage and to avoid irregular wear on the front tyres, it is essential that the wheels be interchanged diagonally with the rear wheels and the spare wheel at least every 3,000 miles (5000 km.) See Fig. 35.

FUEL PUMP

This is bolted on the left-hand forward side of the engine crankcase and has a suction pipe from the tank and an outlet pipe to the carburettor. If petrol appears to be leaking from the edge of the pump diaphragm, tighten the cover screws alternately. Sometimes such leakage may actually come from one of the pipe unions, causing the fuel to run down to the pump and collect around the diaphragm flange.

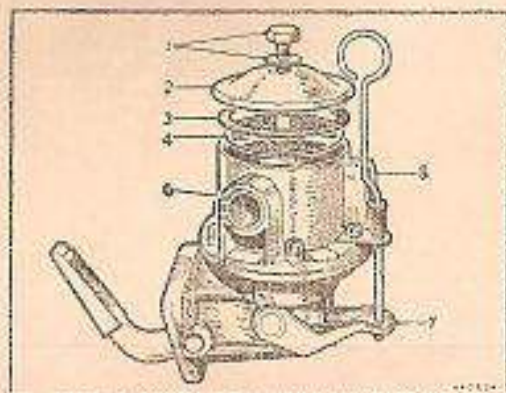

Fig. 36
The fuel pump showing:
1. Cover retaining screw.
2. Cover.
3. Joint washer.
4. Gauge filter.
5. Fuel inlet.
6. Fuel outlet.
7. Priming lever.

The pump filter should be examined, and cleaned, if necessary. Access to it is gained by removing the domed cover, after unscrewing the retaining screw, when the filter gauge itself may be lifted off its seating. Clean out the sediment chamber and clean the filter gauge in an air jet or petrol. The gasket under the filter cover should be renewed, if broken.

When refitting the cover make certain that the fibre washer is replaced under the head of the screw.

Check pump to engine mounting set screws and fuel pipe unions for tightness.

ADJUSTMENTS

CARBURETTER SLOW RUNNING ADJUSTMENT

After the first 1,000 miles or so, when the engine is fully run in, the slow-running adjustment may need a little attention—this should be done when the engine has attained its normal running temperature. If the slow-running speed only (not mixture strength) needs correction, this can be made on the throttle stop screw (A) by turning it clockwise to increase and anti-clockwise to decrease the engine speed.

After the slow-running has been dealt with check that the 'fast idle' adjustment screw (B), which impacts on a cam, is just clear of the impact face by about 1/64 in. (·40 mm.) See Fig. 37.

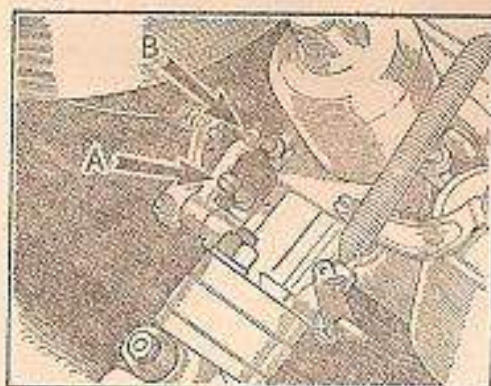

Fig. 37
Arrow (A) indicates the slow running adjustment screw and (B) indicates the 'fast idle' adjustment screw

If, however, the engine beat is uneven, denoting irregular firing, the mixture strength may need adjustment—but remember that defective compression, a faulty valve, or faulty ignition may also cause misfiring.

ADJUSTING THE JET

Uneven firing can be caused by a mixture which is too weak; the exhaust beat then is uneven with a 'splasy' or irregular type of misfire, and the exhaust is colourless. Uneven firing can be caused also by a mixture which is too rich; the misfire is then of a 'rhythmical' or regular type, coupled with a blackish exhaust.

ADJUSTMENTS

According to the symptoms, screw the jet adjusting nut, only one 'flat' of the hexagon at a time, either upwards for weakening or downwards for enrichening until the fastest idling speed is obtained consistent with even firing (See Fig. 38)

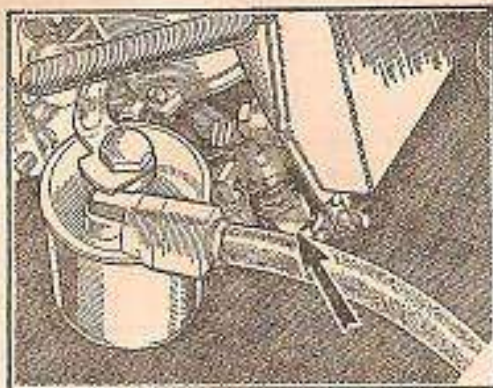

Fig. 38

The jet is adjusted by regulating the position of the spring-loaded nut which forms the abutment for the jet head

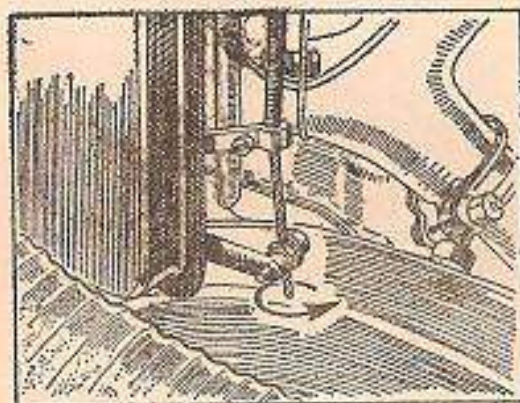

Fig. 39

When refitting the mixture control wire, give inner cable a clockwise twist (looking from the end). This ensures the correct functioning of the control locking device

If a considerable movement of the jet adjusting nut is required (more than three flats) then it is advisable to slacken off the clamp screw anchoring the control wire in the end of the jet lever—for, a lesser movement should not be necessary. When this clamp screw is re-tightened, see that the wire is given a slight twist in the direction indicated in the Fig. No. 39 before final clamping to ensure the proper locking action of the instrument panel control. Also do not clamp this wire so that it is in a taut or stretched condition. It must be slightly slack to ensure that the jet lever may fully return to the 'off' position.

ADJUSTMENTS

When adjusting the mixture strength it may be helpful if the idling speed of the engine is increased by about half a turn of the throttle stop screw—to be suitably reduced later when the correct mixture strength has been obtained.

When the mixture and slow-running speed are satisfactory then the remainder of the throttle range should also be correct.

If the return spring on the jet lever is temporarily disconnected to give spanner access to the jet adjusting nut, make sure that the jet head is abutting hard up against the under side of this nut throughout the adjustment by applying hand pressure on the jet lever.

WINDSHIELD WIPER BLADES

Should it be necessary to re-position the wiper blades on their spindle they can be withdrawn by holding back the small retaining clip, which locates in a register in the spindle, and withdrawing the blade. Replace the blade on the required spline, pushing it hard down on the spindle until retained by the spring clip (See Fig. 40).

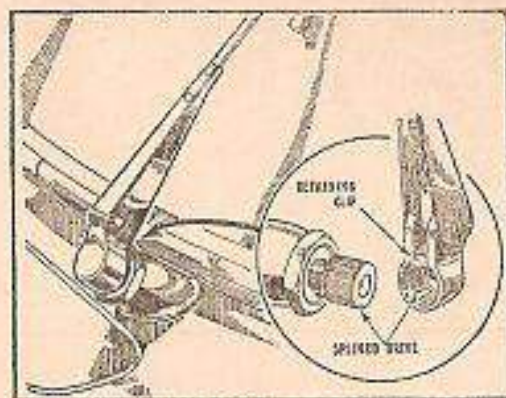

Fig. 40

The wiper blades may be removed by depressing the small retaining clip and withdrawing the blade

MAINTENANCE ATTENTION

Always use the right lubricants. Refer to the lubrication chart for the recommended lubricants at the back of the book.

For a complete summary of the attentions to be given at different mileages refer to H. M. Maintenance Voucher Book being supplied with it.

Every 250 Miles (400 km.)

CHECKING ENGINE OIL LEVEL

Every 250 miles (400 km.) check the supply of oil in the sump by withdrawing the dipstick on the right-hand side of the cylinder block. Wipe the lower portion of the rod, reinsert it, and withdraw it again. Oil will cling to the rod and will show the actual quantity present in the sump. The normal oil level is indicated by the 'MAX' mark on the dipstick. The oil level must not be allowed to drop below 'MIN' mark on the dipstick (See Fig. 41).

This check should be made in the morning before starting engine with the car in level ground. Oil should be topped-up to "MAX" mark. Over-filling will result in heavy oil consumption.

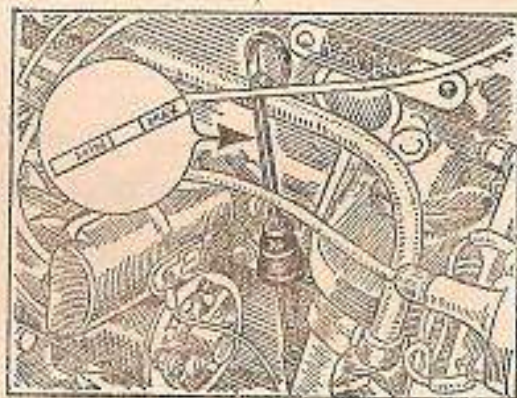

Fig. 41

Inset are shown the markings on the end of the engine oil dipstick

MULTIGRADE MOTOR OILS

In addition to the lubrications recommended in this Book, we also approve the use of appropriate multigrade motor oils produced by oil companies for all climatic temperatures unless the engine is in true mechanical condition.

FILLING UP WITH ENGINE OIL

The filling orifice is at the forward end of the cylinder head cover, and it is provided with a quick-action cap (See Fig. 42).

MAINTENANCE ATTENTION

Clean, fresh oil is essential. Please refer to the oils listed under heading "A" in the Lubrication Chart. For instructions on draining the sump see below.

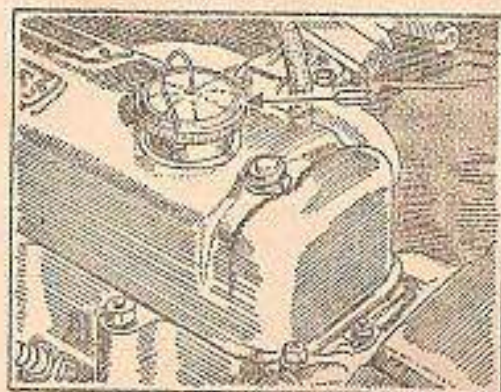

Fig. 42

Turn the oil filler cap anti-clockwise to release it

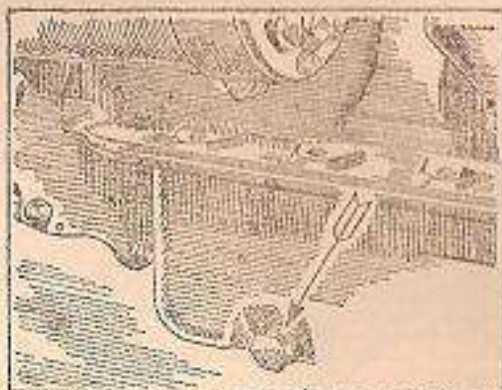

Fig. 43

engine sump drain plug is located on the right-hand side of the engine

First 500 Miles (800 km.)

SUMP AND OIL FILTER

The oil in the sump should be drained after the first 500 miles (800 km.) to clear the sump of any impurities that may have accumulated and refilled with the appropriate grade of lubricant. This operation is best carried out immediately the car returns from a journey, while the oil is still warm and fluid.

MAINTENANCE ATTENTION

On the right-hand side of the engine will be found a hexagon-headed drain plug (See Fig. 43). Removal of this plug will release the contents of the sump. After carefully cleaning the drain plug, it should be replaced and screwed up tightly.

Before refilling the sump withdraw the engine oil filter element by unscrewing the bolt at the bottom of filter (See Fig. 44). Wash the case and the felt element in petrol. Allow the element to dry thoroughly before refitting.

Note:—A paper element should never be washed but changed at every 2,000 miles (3200 km.).

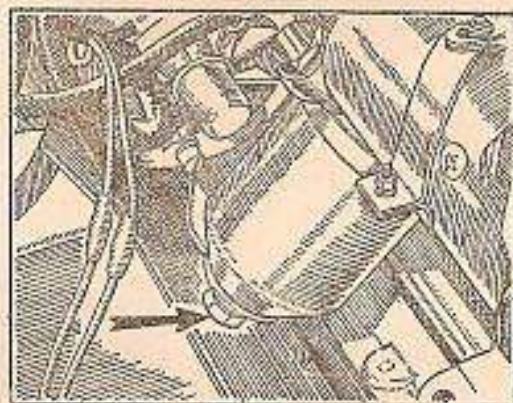

Fig. 44
Unscrew the bolt to release
the oil filter bowl

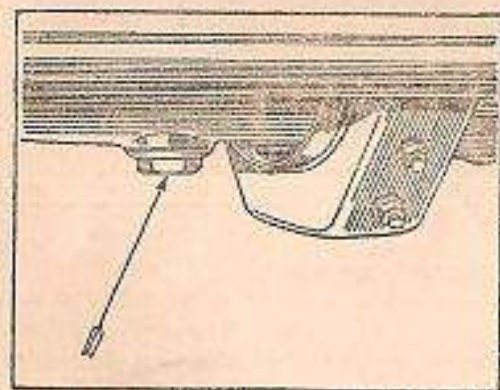

Fig. 45
The arrow indicates the gear
box drain plug

GEAR BOX

This should be drained after the first 500 miles (800 k.m.) by unscrewing the drain plug (See Fig. 45) and then filled with the correct amount

MAINTENANCE ATTENTION

of the recommended lubricant. The filler cap and dipstick are located beneath the rubber cap to the left of the gear box cover and are accessible when the front carpet has been raised (See Fig. 46). Ensure that the hollow centre of the drain plug has been cleaned thoroughly before it is replaced and tightened.

When the gear box has been drained completely, 1.14 litres (2 pints) of oil are required to fill it. The oil should be poured in through the filler plug until it reaches the "full" mark on the dipstick.

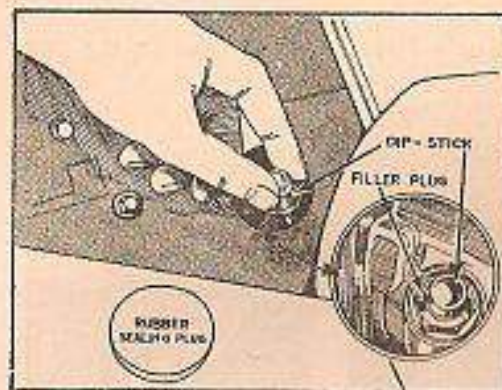

Fig. 46
Inset shows the gear box filler
plug and the dipstick

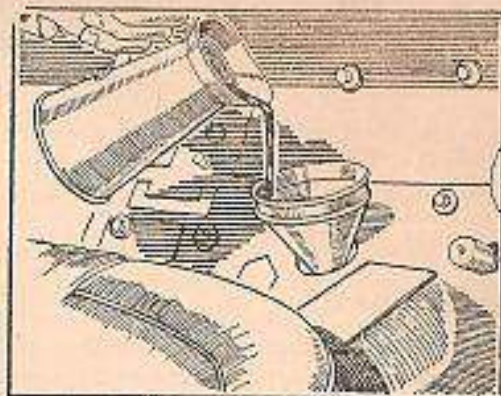

Fig. 47
Filling up the gear box with oil

Before refilling the gear box completely, unscrew the plug located on the extension casing and on the same side as the selector bends and pour in a little quantity (not exceeding 10 c.c.) by means of a oil can.

MAINTENANCE ATTENTION

REAR AXLE

A square headed drain plug is fitted at the bottom of the differential housing and its hollow centre must be cleaned before it is replaced and tightened (See Fig. 48).

The oil should be drained from the rear axle after the first 500 miles (800 k.m.). The axle must then be filled with the recommended lubricant upto the level of the filler plug. Approximately 1.14 litres (2 pints) of oil are required to refill the axle.

Note:—It is essential that only Hypoid Oil be used in the rear axle.

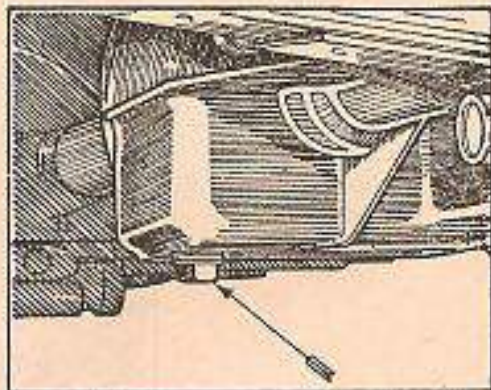

Fig. 48
Arrow indicates rear axle drain plug

WATER PUMP

It is essential that proper attention is given to the lubrication of the water pump bearing. The recommended grease for the lubrication of the water pump bearing is "Shell Retinax A" or its equivalents. Unscrew the bearing lubricating screw and apply a little quantity of the recommended grease (max. 5 c.c.). **DO NOT USE GREASE GUN.** This will prevent excessive grease from getting inside and finally going past the seals and thus causing the pump to leak.

MAINTENANCE ATTENTION

Every 5,00 Miles (800 km.)

Repeat the items listed under every 250 miles (400 k.m.) and add the followings:

PROPELLER SHAFT

The sliding joint and two needle type universal joints should receive grease gun attention every 5,00 miles (800 k.m.) (See Fig. 49). Please refer to the lubricants under the heading 'D' on the lubrication chart.

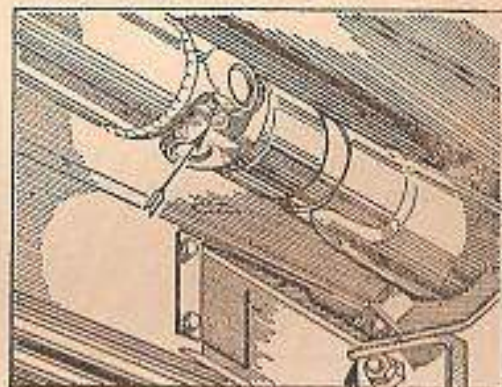

Fig. 49
The arrow indicates the grease nipple for the rear universal joint

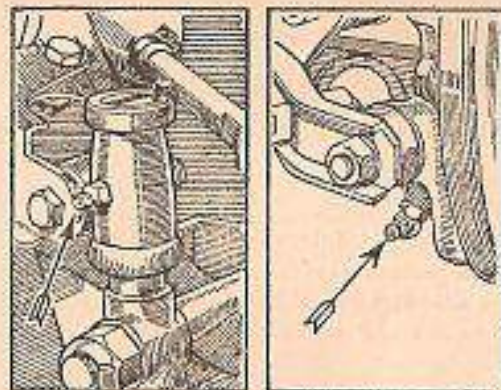

Fig. 50
Two grease nipples, one at the top and one at the bottom, are provided for swivel pin lubrication

THE SWIVEL PINS

Grease nipples are provided at the top and bottom of each swivel pin. The grease gun should be applied to the nipples every 5,00 miles (800 k.m.) (See Fig. 50). Three or four strokes of the gun should be given. Please refer to the lubricants under the heading 'D' on the Lubrication Chart.

MAINTENANCE ATTENTION

TIE-ROD ENDS

Every 5,00 miles (800 km.) the grease gun should be applied to the nipple on the ends of steering tie-rods and given three or four strokes (See Fig. 51). The inner ball joints of the tie-rods (those with the rubber boots) are automatically lubricated from steering gear box housing. Please refer to the lubricants under the heading 'D' on the Lubrication Chart.

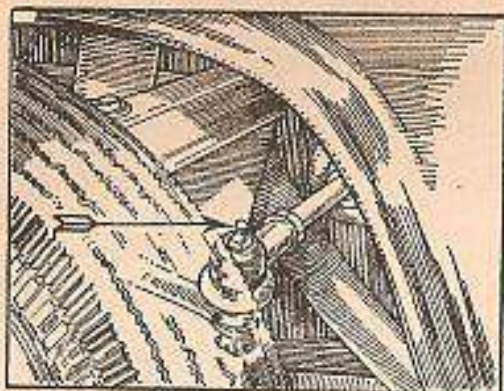

Fig. 51
One grease nipple is fitted on the end of each tie-rod

Test the tyre pressures including spare tyre. See that the radiator is full of water.

Every 1,000 Miles (1600 km.)

Repeat the items listed under every 500 miles (800 km.) and add the followings:

GEAR BOX OIL REPLENISHMENTS

Replenishments should take place at intervals of 1,000 miles (1600 km.). Care should be taken to ensure that the gear box is not filled above the "full" mark on the dipper rod. If the oil level is too high, oil may get into the clutch housing and cause clutch slipping.

REAR AXLE

The rear axle should be topped up every 1,000 miles (1600 k.m.).

SUMP AND OIL FILTER

The oil in the sump should be changed every 1,000 miles (1600 km.) to clear the sump of any impurities that may have accumulated and refilled with the appropriate grade of lubricant as per instructions given in the first 5,00 miles (800 km.) service.

MAINTENANCE ATTENTION

MASTER CYLINDER

The fluid level must be checked by turning back the front floor carpet on the driver's side and removing the exposed rubber plug. This will in turn expose the master cylinder filler plug, which should be removed. The fluid should be within $\frac{1}{2}$ in. (13 mm.) of the bottom of the filler neck but not above this. Replenish if necessary with (Lockheed Genuine Brake Fluid, 103—for A.P.I. Brakes) or (Girling Brake Fluid S.A.E. 70 R 3—for Brakes India Brakes).

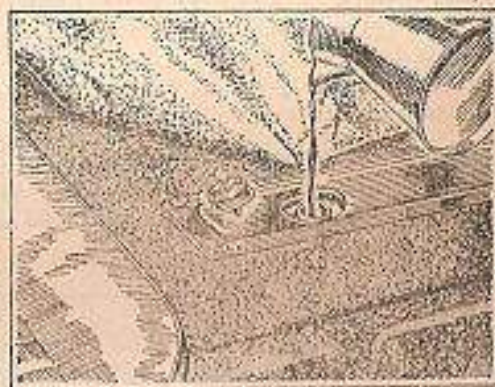

Fig. 52
The master cylinder filler cap is located beneath the carpet and on the floor on the driver's side



Fig. 53
Lubricating the carburettor piston damper

CARBURETTOR DAMPER

This reservoir needs topping up periodically with thin engine oil to Ref. F. (on Lubrication Chart). This operation is not at all critical; simply, unscrew and remove the damper unit and then pour oil into the hollow piston rod until the level is $\frac{3}{4}$ in. (13 mm.) from the top of the rod, then re-screw the damper back into position. It is suffi-

MAINTENANCE ATTENTION

cient to withdraw the damper unit far enough to insert the nozzle of an oilcan. The function of this piston damper unit is to provide an appropriate degree of enrichment for acceleration, and also to improve cold starting.

BONNET LOCK

The oilcan should be applied to the sliding surfaces of the spring-loaded lever on the lower portion of the lock, and to the pivot of the safety catch.

PROPELLER SHAFT FRONT UNIVERSAL JOINT

The grease gun, filled with grease to Ref. D (on Lubrication Chart) should be applied to the front universal joint nipples every 1,000 miles (1600 k.m.) and given three or four strokes. Access is obtained from underneath the car.

HAND BRAKE CABLE

The grease nipple on the hand brake cable should be given three or four strokes with a grease gun filled with grease to Ref. E (on Lubrication Chart).

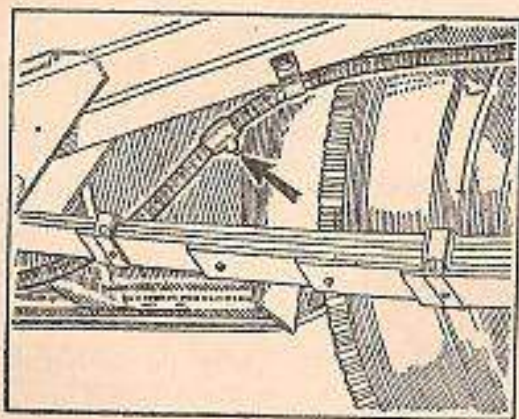

Fig. 54
The hand brake cable grease nipple is accessible from beneath the vehicle

CHECKING SPECIFIC GRAVITY

Check the condition of the battery by taking hydrometer readings of the specific gravity of the electrolyte in each of the cells. Readings should not be taken immediately after topping up the cells. The specific gravity readings and their conditions are as follows:—

1.200-1.215 Battery fully charged.

About 1.175 Battery about half-discharged.

Below 1.125 Battery fully discharged.

These figures are given assuming that the temperature of the solu-

MAINTENANCE ATTENTION

tion is about 60 F. (16° C). The readings for all cells should be approximately the same. If one cell gives a reading very different from the rest, it may be that acid has been spilled or has leaked from this particular cell or there may be a short circuit between the plates (See Fig. 55).

CHECKING SPECIFIC GRAVITY

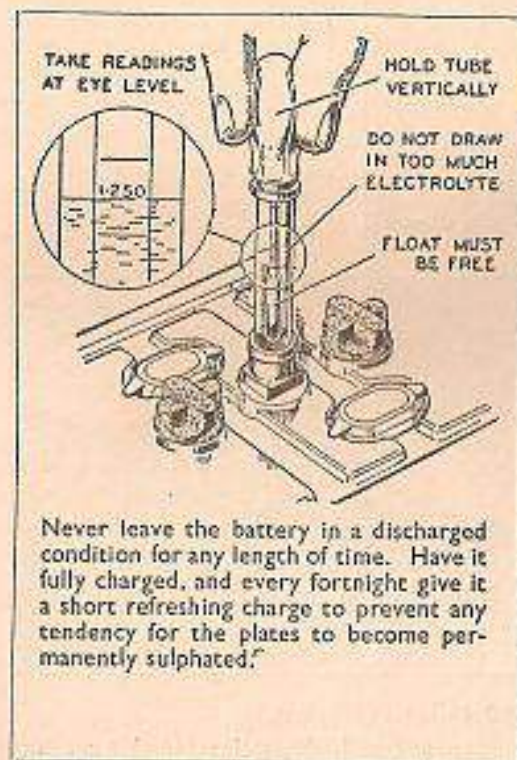

Fig. 55
The hydrometer in use, checking the specific gravity of the electrolyte

Never leave the battery in a discharged condition for any length of time. Have it fully charged, and every fortnight give it a short refreshing charge to prevent any tendency for the plates to become permanently sulphated.

AIR CLEANER

Slacken the screw-type clip securing the air cleaner body to the intake pipe, release the breather pipe and withdraw the air cleaner mplete from the engine.

Transfer the air cleaner to a bench, taking care not to spill the oil.

Remove the central wing bolt to release the top cover and filter

MAINTENANCE ATTENTION

gauge, which should be washed in petrol (gasoline) or paraffin (kerosene). Drain and dry it thoroughly before replacing.

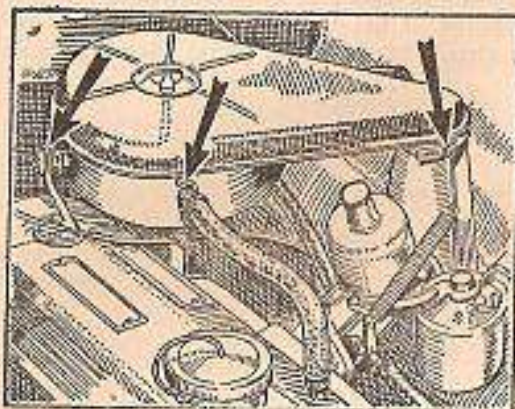

Fig. 56
The arrows indicate the two clips and the rubber-mounted spigot which secure the air cleaner

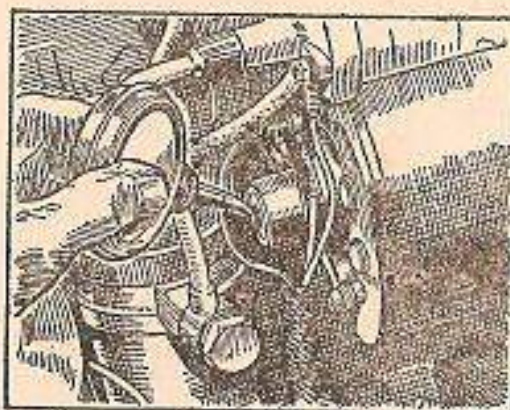

Fig. 57
The lubrication hole for the dynamo end bearing. Do not over lubricate

Every 3,000 Miles (4800 km.)

Repeat the items listed under every 1,000 miles (1600 km.) and add the followings:

ENGINE OIL FILTER

If the filter element is of felt type then it should be removed and cleaned in petrol every 3,000 miles. Alternatively the filter element (felt) should be renewed every 6,000 miles (9600 km.).

Note:—Paper element must be renewed every 2000 miles (3200 km.)

DYNAMO LUBRICATION

Add two drops of oil to Ref. F (on Lubrication Chart) to the rear end of the dynamo. Use an oilcan inserted in the central hole of the rear end bearing (See Fig. 57). Avoid Over-Oiling.

MAINTENANCE ATTENTION

CONTACT BREAKER PIVOT

Place a small amount of clean engine oil or grease to Ref. C (on Lubrication Chart) on the pivot on which the contact breaker lever works. Do not allow oil or grease to get on the contacts. Use lubricant sparingly.

CONTACT BREAKER GAP

Remove the distributor cap and turn the engine by hand until the contacts are fully opened. Check the gap with the .016 in. (.40 mm.) gauge on the screw-driver supplied in the tool kit; the gauge should be a sliding fit in the gap. If the gap varies appreciably from the gauge, slacken the contact plate securing screw (See Fig. 58) and adjust the contact gaps by inserting a screw-driver in the notched hloes at the end of the plate, turn clockwise to decrease and anti-clockwise to increase the gap. Tighten the securing screw.

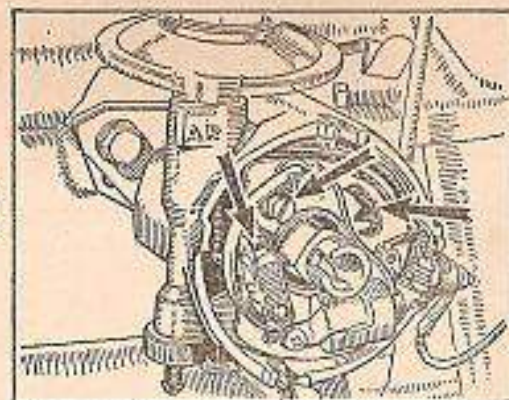

Fig. 58
The distributor points, contact plate securing screw, and the screw driver adjusting slots are indicated here by the arrows

If the contact breaker points are burned or blackened, clean them with a fine carborundum stone or with very fine emery-cloth.

Cleaning of the contacts is made easier if the contact breaker lever carrying the moving contact is removed. To do this, unscrew the nut securing the end of the spring, remove the spring washer, flat washer, and both wire terminals, and lift off the lever complete with spring. After cleaning, check the contact breaker setting on replacement.

DISTRIBUTOR CAM

Lightly smear the cam with a very small amount of grease to Ref. D (on Lubrication Chart) or clean engine oil can be used.

MAINTENANCE ATTENTION

DISTRIBUTOR CAM BEARING

Lift the rotor off the top of the spindle by pulling it off squarely and add a few drops of thin engine oil to the cam centre. Do not remove the screw which is exposed to view. There is a clearance between the screw and the inner face of the spindle for the oil to pass.

Replace the rotor with its drive plug correctly engaging the spindle slot and push it on the shaft as far as it will go.

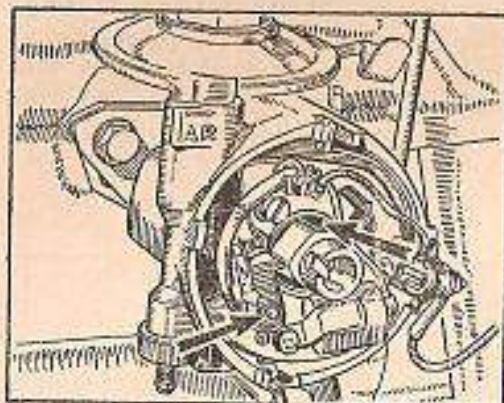

Fig. 59

A slight trace of grease or engine oil should be applied to the rotating cam. The cam bearing should also receive a few drops of oil.

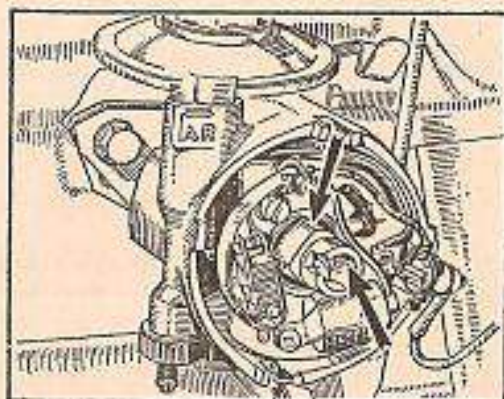

Fig. 60

Lubricate the advance mechanism and the contact breaker lever pivot at the stipulated interval

AUTOMATIC TIMING CONTROL

Carefully add a few drops of thin engine oil through the hole in the contact breaker base through which the cam passes. Do not allow any oil to get on or near the contacts.

Do not over-oil.

MAINTENANCE ATTENTION

SPARKING PLUG

The sparking plugs fitted to the car are Mico Bosch 14 mm., (HW-145T2). The gap between the points should be .025 in. (.64 mm.). When adjusting the gap always move the side wire; never bend the centre wire.

The only efficient way to clean sparking plugs is to have them properly serviced on machines specially designed for this purpose. These machines operate with compressed air and utilize a dry abrasive material specially graded and selected to remove harmful deposits from the plug insulator without damaging the insulator surface. In addition, the majority of the machines incorporate electrical testing apparatus enabling the plugs to be pressure-tested to check their electrical efficiency and gas-tightness.

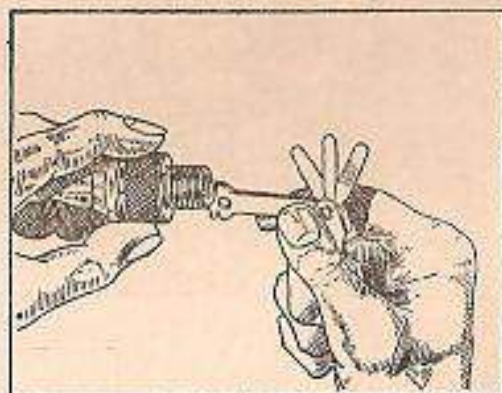

Fig. 61

To adjust the gap use the special sparking plug gauge and setting tool and move the side wire on the plug; never the centre one

BRAKE ADJUSTMENTS

Excessive brake pedal travel is an indication that the brake-shoes require adjusting.

The brakes on all four wheels must be attended to as detailed below to regain even and efficient braking.

When re-lining front or rear brake shoes, it is important that the shoes on both sides of the car are attended to at the same time. Never re-line the shoes for one wheel without attending to the opposite side.

Two types of brakes are being fitted on cars currently produced (1) Lock head type manufactured by M/s. Automobile Product of India Ltd. (A. P. I.) (2) Girling type manufactured by M/s. Brakes India Ltd. For identification, please refer to Figure Nos. 62 to 64 (A. P. I.) and 65 to 67 (Brakes India). In case of difficulty in identification, please contact the authorised Hindustan Dealer.

MAINTENANCE ATTENTION

FRONT BRAKES (A.P.I.)

Remove the front hub cap and rubber wheel plug and rotate the wheel or brake drum until one of the adjustment screws is visible through the hole provided. With a screwdriver turn the screw as far as it will go in a clockwise direction until the drum is locked solid, then turn the screw anti-clockwise—one notch only. The brake drum should then be free to rotate without the shoes rubbing. Carry out the same procedure on the screw which is diametrically opposite. The brake-shoes on this wheel are now fully adjusted. The brake-shoes on the other front wheel must be similarly adjusted. Do not forget to replace the rubber dust excluder plug.

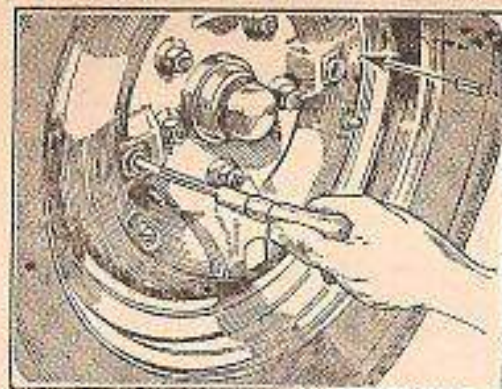

Fig. 62
Adjust one shoe, then turn the wheel half a turn to gain access to the second adjuster
(A. P. I.)

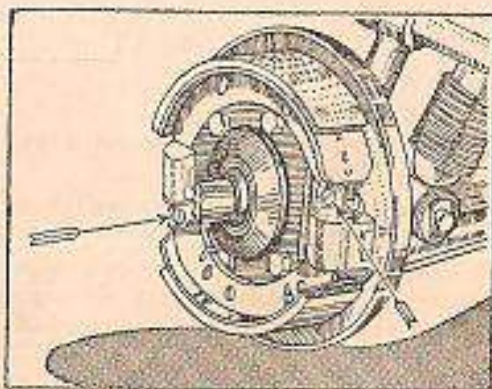

Fig. 63
The arrows indicate the two brake-shoe adjusting screws on the front assembly
(A. P. I.)

REAR BRAKES (A.P.I.)

The procedure is similar to that detailed above for the front brakes, except that there is only one adjuster, which controls both brake-shoes (See Fig. 64).

MAINTENANCE ATTENTION

It is essential that the hand brake should be fully released while the rear brake-shoes are being adjusted. Do not forget to replace the rubber plug.

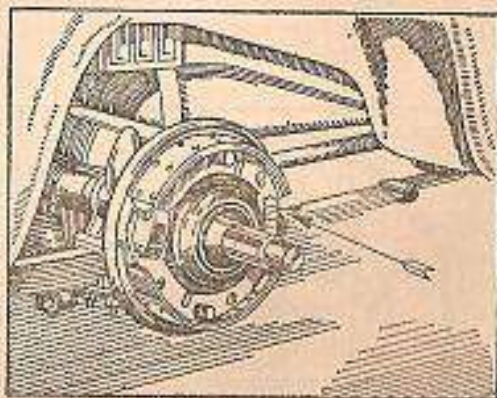

Fig. 64
A single adjustment screw only is provided on the rear brake which automatically adjusts the hand brake at the same time
(A. P. I.)

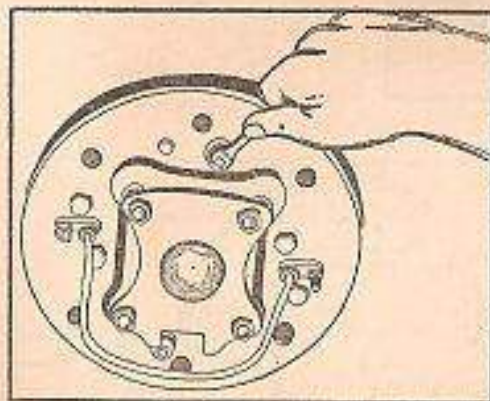

Fig. 65
Adjust one shoe and then the other one by turning the square head provided for the purpose
(Brakes India-Brakes)

FRONT BRAKES (Brakes India)

With a $\frac{1}{2}$ in. spanner turn the square head (See Fig. 65) as far as it will go in a clockwise direction until the drum is locked solid, then turn the head anti-clockwise till the drum is just free to rotate. Carry out the same procedure on the square head which is diametrically opposite. The brake-shoes on this wheel are now fully adjusted. The brake-shoes on the other front wheel must be similarly adjusted.

REAR BRAKES (Brakes India)

The procedure is similar to that detailed for the front brakes, except

MAINTENANCE ATTENTION

that there is only one adjuster, which controls both brake-shoes (See Fig. 66).

It is essential that the hand brake should be fully released while the rear brake-shoes are being adjusted.

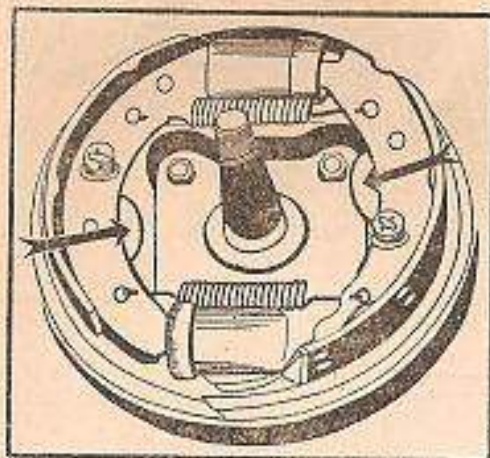

Fig. 66
The arrow indicates the two brake-shoe adjusting cams on the front assembly (Brakes India-Brakes)

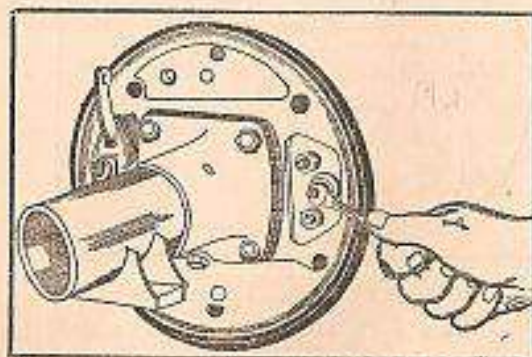

Fig. 67
A single adjustment screw only is provided on the rear brakes which automatically adjust the hand brake at the same times (Brakes India-Brake)

DYNAMO DRIVING BELT

Inspect the dynamo driving belt and adjust, if necessary, to take up any slackness. Care should be taken to avoid overtightening the belt, otherwise undue strain will be thrown on the dynamo bearings.

MAINTENANCE ATTENTION

The belt tension is adjusted by slackening the bolts of the dynamo cradle and moving the dynamo the required amount by hand in the slotted link (See Fig. 68).

Tighten up the bolts thoroughly.

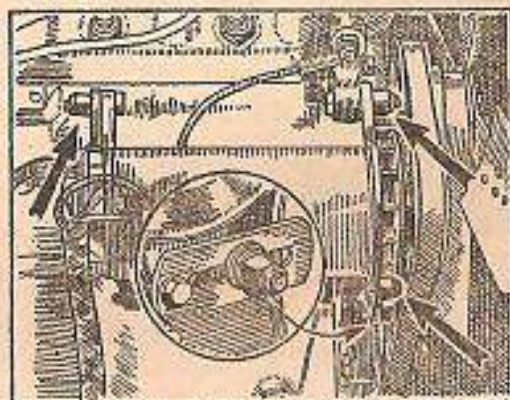

Fig. 68
The four points of attachment for the dynamo, all of which must be slackened for belt adjustment

Every 6,000 Miles (9600 km)

Repeat the items listed under every 3,000 miles (4800 km.) and add the followings.

EXTERNAL ENGINE OIL FILTER

The external engine oil filter container should be removed and the filter element (felt) should be taken out and replaced by a new one. Clean the filter element casing in petrol and dry thoroughly before replacing.

Note:—Paper element must be renewed every 2,000 miles (3200 km.)

GEAR BOX

The gear box should be drained and then filled with fresh oil every 6,000 miles (9600 km.).

MAINTENANCE ATTENTION

REAR AXLE

The rear axle should be completely drained and then refilled with fresh lubricants every 6,000 miles (9600 k.m.).

VALVE ROCKER CLEARANCE

Both inlet and exhaust valves should have a clearance of at least .015 in. (.38 mm.) when hot.

It is of the utmost importance to set:

No. 1 valve with	No. 8 fully open.
No. 3 " "	No. 6 " "
No. 5 " "	No. 4 " "
No. 2 " "	No. 7 " "
No. 8 " "	No. 1 " "
No. 6 " "	No. 3 " "
No. 4 " "	No. 5 " "
No. 7 " "	No. 2 " "

To adjust the clearance, slacken the adjusting screw locknut on the opposite end of the rocker arm and rotate the screw clockwise to reduce the clearance and anti-clockwise to increase it. Re-tighten the locknut when the clearance is correct, holding the screw against rotation with a screwdriver. (See Fig. 69)

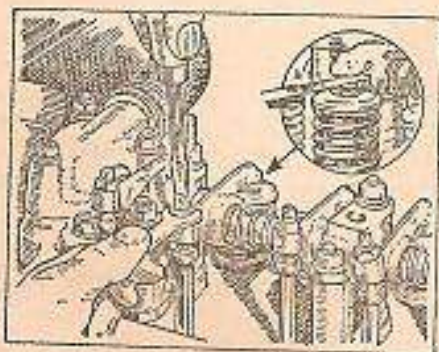

Fig. 69
The method of setting valve clearance, and (inset) using a feeler gauge to check the clearance

FRONT WHEEL HUBS

Remove the hub disc and prise off the hub grease cap from the

MAINTENANCE ATTENTION

end of the hub with a screwdriver (See Fig. 70). Fill the cap with grease to Ref. C (on Lubrication Chart) and place it back properly.

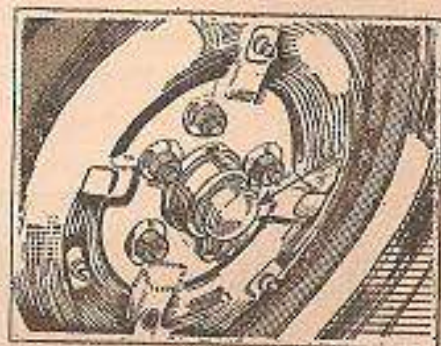

Fig. 70
The front hub grease cap must be gently prised off with a screwdriver

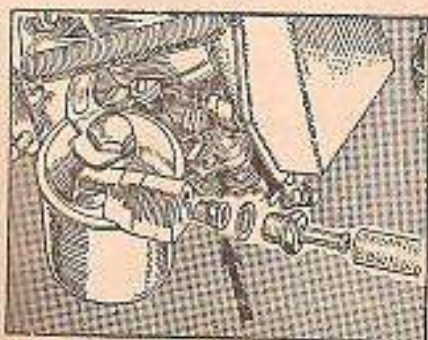

Fig. 71
The carburettor filter must be replaced with the open end outwards

CARBURETTER FILTER

The float-chamber filter should be removed and thoroughly cleaned with a stiff brush and petrol (gasoline). Never use rag. The filter is situated at the junction of the fuel pipe to the float-chamber lid. Replace the filter with its helical spring inwards and its open end outwards (See Fig. 71).

MAINTENANCE ATTENTION

STEERING GEAR

Tracking up the wheels. Excessive and uneven tyre wear is usually caused by faulty wheel tracking. The wheels should toe in to the extent of $\frac{3}{32}$ in (2.4 mm.). Ensure that the measurements are taken at axle level and the rims run true. Correct setting of the front wheels entails the use of a wheel alignment gauge, and the owner is advised to entrust this work to an Authorised Hindustan Dealer, who has the necessary equipment.

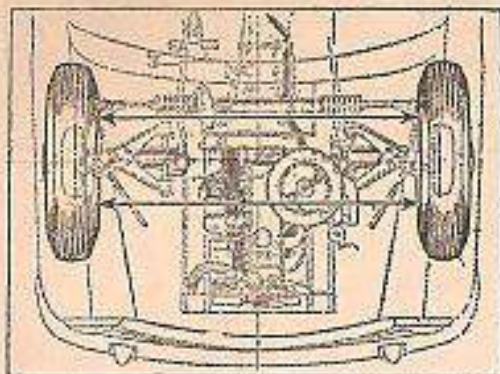

Fig. 72

At axle level the distance between the rims at the rear should be $\frac{3}{32}$ in. (2.4 mm.) greater than that at the front of the wheel rims

Every 12,000 Miles (19200 km.)

Repeat the items listed under every 6,000 miles (9600 km.) and then add the followings.

WATER PUMP

Once every 12,000 miles (19200 km.) or whenever a water pump is reconditioned, unscrew the bearing lubricating screw and apply a measured quantity of 5 c.c. of Shell Retinax A or equivalent type of grease. DO NOT USE GREASE GUN.

STEERING GEARBOX

A nipple is provided on the rack housing and is accessible from under the bonnet. Replenish the rack assembly with oil to Ref. B (on Lubrication Chart) and avoid overfilling the steering gearbox. Give no more than 10 strokes. A grease nipple is fitted on the pinion

MAINTENANCE ATTENTION

shaft to which the grease gun should also be applied and given two strokes (See Fig. 73).

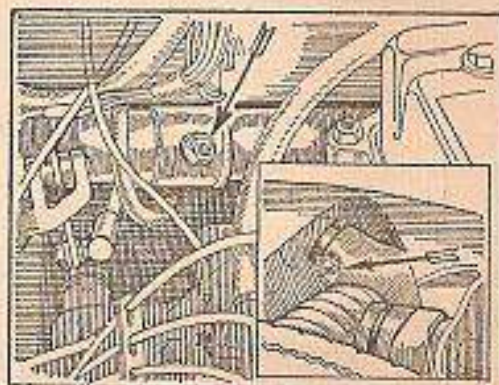

Fig. 73

The steering rack oil nipple is accessible from beneath the bonnet. Inset shows the nipple for the pinion shaft

RADIATOR

Open both drain taps on the engine and radiator. Allow the coolant to drain. Remove the radiator filler cap and insert a hose in the top of the radiator. Allow the water to run for several minutes to swill out the radiator and cylinder block passages.

Refill the system with water (preferably soft), or one of the recommended anti-freeze coolants.

HYDRAULIC DAMPERS

The hydraulic damper fitted are carefully set before despatch. They are non-adjustable and their construction is such that no dismantling can be carried out except by the makers. If they show signs of free movement, lack of adequate resistance, or excessive resistance, they must be renewed.

CARBURETTOR PISTON

The suction chamber and piston should be cleaned approximately every 12,000 miles (19,200 km.). After detaching the unit clean the main inside bore of the suction chamber and the outside diameter of the piston with a clean rag moistened in fuel. Reassemble in a clean and dry condition with a few spots of clean thin oil (Ref. F. on Lubrication Chart) on the piston rod only. Do not forget to refill the damper reservoir (see page 41 and Fig. No. 53).

Detach the float-chamber by unscrewing the attachment bolt, remove the lid and float, and empty away any sediment which may have collected in the bottom of the chamber.

WIRING DIAGRAM

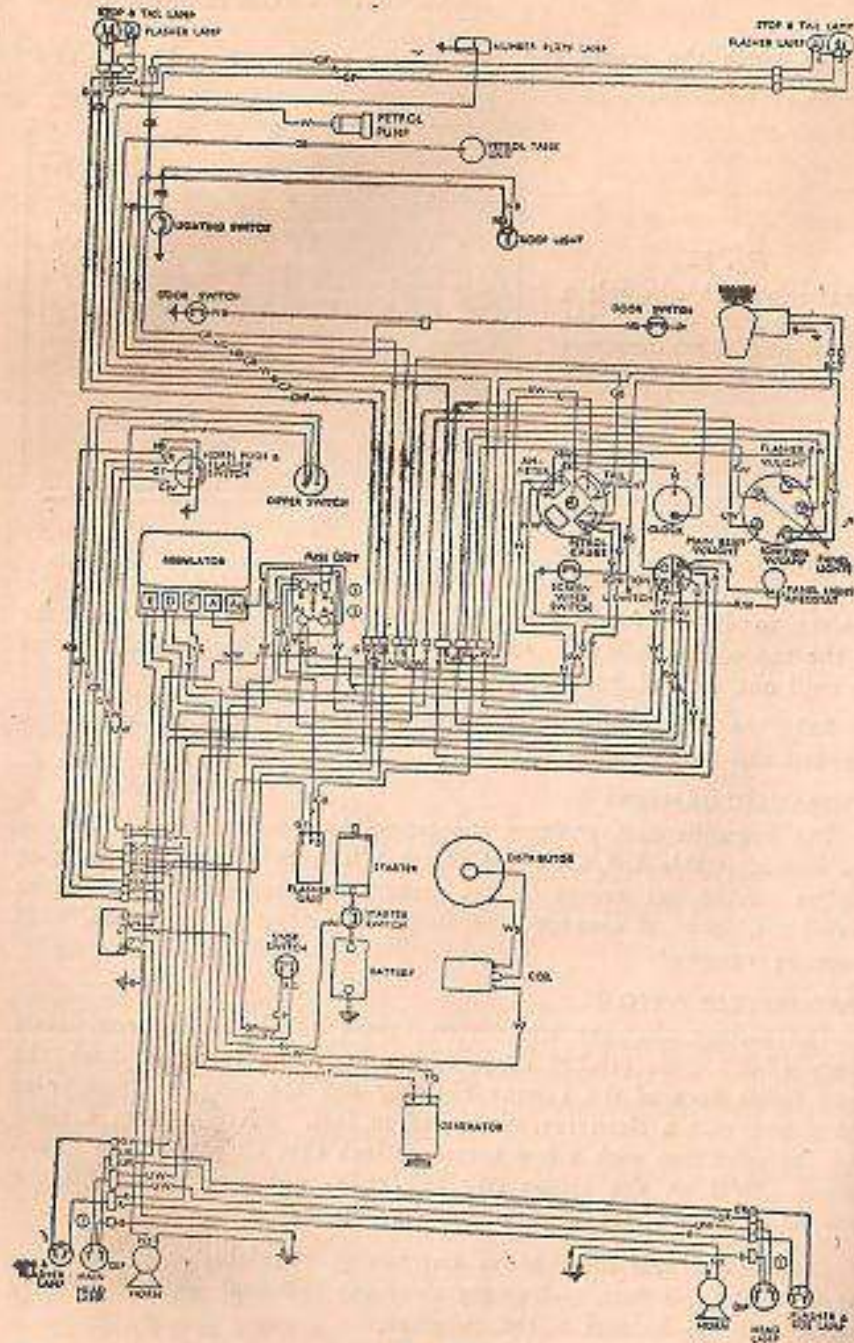

Fig. 74

KEY TO WIRING DIAGRAM

- L.H. side & flasher lamp.
- L.H. headlamp.
- L.H. horn.
- R.H. side & flasher lamp.
- R.H. headlamp.
- R.H. horn.
- Generator.
- Stop switch.
- Battery.
- Coil.
- Starter switch.
- Flasher unit.
- Starter.
- Distributor.
- Fuse unit.
- Regulator.
- Screenwiper switch.
- Ignition and light switch.
- Panel light Rheostat.
- Petrol gauge.
- Main-beam W/Light.
- Ignition W/Lamp. Panel lights
- Am-meter.
- Tail W/Light.
- Flasher W/Light.
- Dipper switch.
- Horn push & flasher switch.
- Door switch.
- Screen wiper.
- Lighting switch.
- Roof light.
- Petrol tank unit.
- L.H. stop & tail lamp.
- L.H. flasher lamp.
- Number plate lamp.
- R.H. stop and tail lamp.
- R.H. flasher lamp.

CABLE COLOUR CODE

- B — Black
- G — Green
- N — Brown
- P — Purple
- R — Red
- U — Blue
- W — White
- Y — Yellow
- GB — Black Green
- GB — Green Black
- GP — Green Purple
- GR — Green Red
- GW — Green White
- GY — Green Yellow
- NB — Brown Black
- NG — Brown Green
- NU — Brown Blue
- NW — Brown White
- NY — Brown Yellow
- RG — Red Green
- RW — Red White
- RY — Red Yellow
- UR — Blue Red
- UW — Blue White
- WB — White Black
- YG — Yellow Green

THE AMBASSADOR LUBRICATION CHART

Shell or Shell Deter U	"Caltex" Upper Cylinder Lubricant	"Esso" Top Lube
"Caltex" RPM Motor Oil SAE 20 HD	"Esso" Motor Oil 20	
"Caltex" Marfak 2 HD	"Esso" Multi-purpose Grease H	
"Caltex" Marfak 2 HD	"Esso" Multi-purpose Grease H	
"Caltex" Marfak 2 HD	"Esso" Multi-purpose Grease H	
"Caltex" Universal Thuban 90	"Esso" Gear Oil G.P. 80	
"Caltex" Universal Thuban 90	"Esso" Gear Oil G.P. 90	
"Caltex" RPM Motor Oil SAE 10/10W	"Esso" Motor Oil 10	
"Caltex" RPM Motor Oil SAE 20 HD	"Esso" Motor Oil 20	
"Caltex" RPM Motor Oil SAE 30 HD	"Esso" Extra Motor Oil	
"CALTEX"	"ESSO" Standard Eastern, INC	

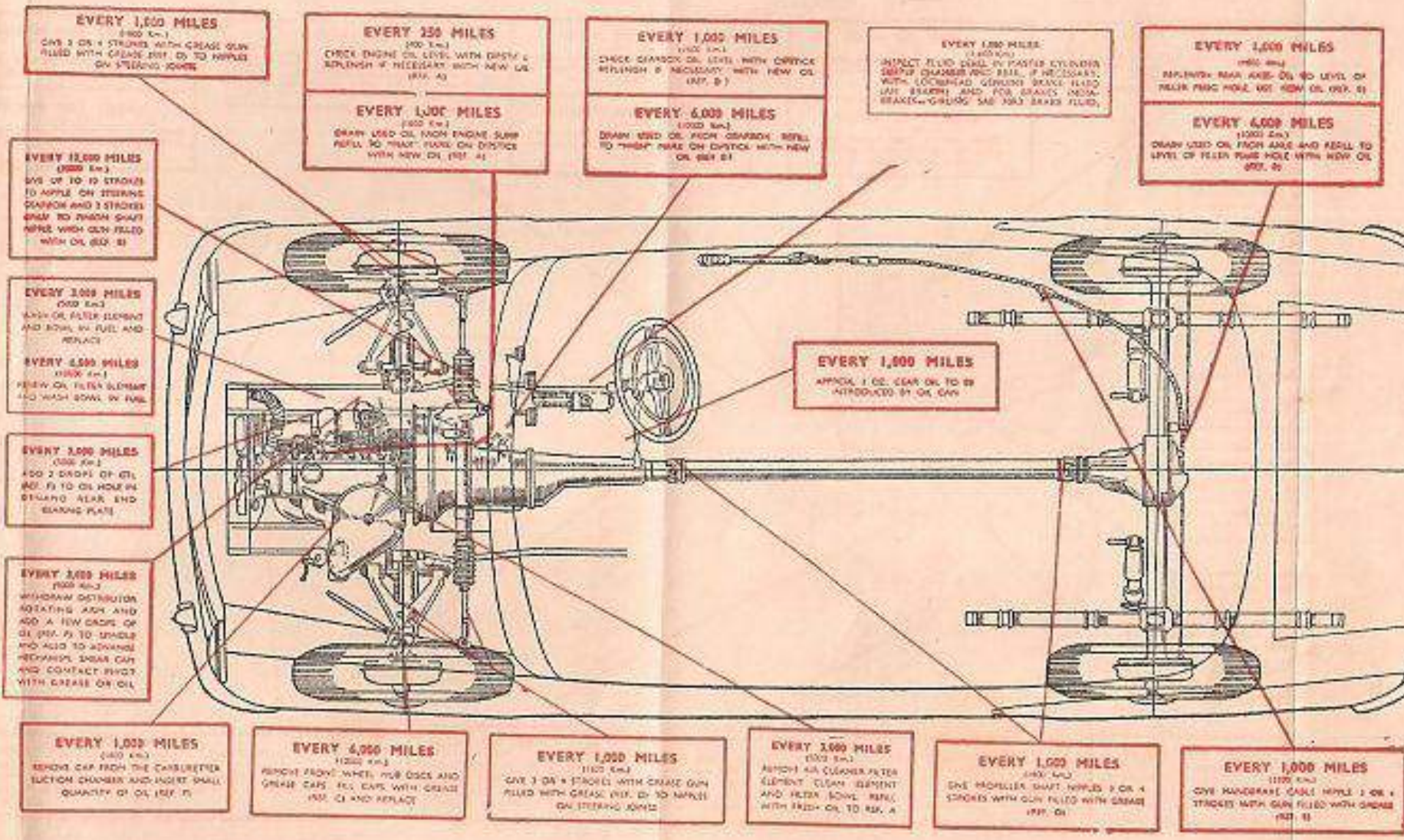

Every 1,000 Miles (1600 Km.). Use oil can filled with oil to Ref. F on all control joints, door lock, bonnet locks, hinges, etc.
 Every 6,000 Miles (10000 Km.). Remove grease plug from fan and water pump housing and insert a small amount of grease to Ref. C in opening, with the fingers only.
 Note. In extreme cold use the lighter lubricants indicated for extreme conditions.

APPROVED ALTERNATIVE LUBRICANTS

Component	A Engine and Air Cleaner			B Gearbox, Steering Gear-box and Rear Axle (Hypoid Gears)		C Wheel Hubs and Fan Bearings	D Chassis Greasing, Nipples and Springs	E Cables and Control Points	F Oilcan and Carburetter	G Upper Cylinder Lubrication
	Climatic Conditions	Tropical and temperate down to 32°F.	Extreme cold down to 10°F.	Arctic consistently below 10°F.	Tropical and temperate down to 10°F.	Extreme cold below 10°F.	All conditions	II conditions	All conditions	All conditions
"CASTROL" (Castrol Limited)	"Castrol" X.L.	"Castrolite"	"Castrol" Z	"Castrol" Hypoy	"Castrol" Hypoy light	"Castrol-lease" Heavy	"Castrol-lease" Medium	"Castrol-lease" Brake Cable Grease	"Castrolite"	Castrollo
"MOBIL" (Indian Oil)	Mobiloil "A"	Mobiloil "Arctic"	Mobiloil 10W	Mobilube "GX90"	Mobilube "GX80"	Mobil Grease "MP"	Mobilgrease "MP"	Mobilgrease "MP"	Mobiloil "Arctic"	Mobil Upperlube
"SHELL" (Burmah Shell)	"Shell" X-100 30	"Shell" X-100 20/20W	"Shell" X-100 10W	"Shell" Spirax 90 "E.P."	"Shell" Spirax 80 "E.P."	"Shell" Retinax A	"Shell" Retinax A	"Shell" Retinax A	"Shell" X-100 20/20W	"Shell" Upper Cylinder Lubricant or Shell Donax U
"CALTEX"	"Caltex" RPM Motor Oil SAE 30 HD	"Caltex" RPM Motor Oil SAE 20 HD	"Caltex" RPM Motor Oil SAE 10/10W	"Caltex" Universal Thuban 90	"Caltex" Universal Thuban 90	"Caltex" Marfak 2 HD	"Caltex" Marfak 2 HD	"Caltex" Marfak 2 HD	"Caltex" RPM Motor Oil SAE 20 HD	"Caltex" Upper Cylinder Lubricant
"ESSO" Standard Eastern, INC	"Esso" Extra Motor Oil	"Esso" Motor Oil 20	"Esso" Motor Oil 10	"Esso" Gear Oil G.P. 90	"Esso" Gear Oil G.P. 80	"Esso" Multi-purpose Grease H	"Esso" Multi-purpose Grease H	"Esso" Multi-purpose Grease H	"Esso" Motor Oil 20	"Esso" Top Lube