

SAIPA

Owner's Manual
SAIPA Family (111, 131, 132, 141)
equipped with (electronic injection fuel supply
system, Euro 4, hydraulic power steering, Bi-fuel
CNG, anti-theft system, ABS braking system)
Second edition



SAIPA Company

All rights reserved. No part of this publication may be reproduced in any material form (including photocopying or storing in any medium by electronic means and whether or not transiently or incidentally to some other use of this publication) without the SAIPA Corporation permission except in accordance with the provisions of the copyright.



Attention

Because performing the periodical services according to the manufacturer recommendations, has important effect on improving the vehicle performance and increasing its useful life, performing of these services (like replacing oil and oil filter of the engine) according to the table of vehicle periodical services (warranty chapter in this manual) and in the authorized dealership of SAIPA is mandatory. Surrendering these services, cancels the vehicle warranty. Therefore, if you want to use the vehicle warranty, it is necessary to refer to the authorized dealerships of SAIPA to perform the services (in maximum 1000km mileage after the limitation mileage or one month after deadline, which are defined in the table of periodical services).

Preface

Thanks and congratulation for your best choice in buying a new vehicle from our company. Please read carefully the owner's manual before driving. This book includes valuable and vital information regarding driving and introduces the vehicle equipment and components. Furthermore, the maintenance procedure and service timetable of the vehicle are instructed in the manual. We hope by having knowledge about driving and knowing vehicle's equipment, you experience a comfortable and relaxed driving using SAIPA products.

SAIPA Company History

Iranian Corporation of Citroen Automotive Manufacturing was established in 1965 in a 240,000 square meter area with a 20,000 square meter building and 160 million Iranian Rials as initial Capital. Now, it is extended to 415,000 square meters as a central factory. This company in its initial stage of establishment started its activities by thirty persons as its personnel. After a year, the Company's personnel increased to 600 persons out of whom them 150 persons

were working in the assembly line.









On July 16, 1967, before first production supply into the market, the managing director of the company requested a registered mark of SAIPAC which is the abbreviation of «SOCIETE ANNONYME IRANIENNE DE PRODUCTION AUTOMOBILE CITROEN» with the word of «Djian» for all models of automotives. In 1973, the company received agreement of the RENAULT Company of France to produce the RENAULT manufactured automotives. Following the Ministry of Industry and Mines agreement, the company removed the word «Citroen» from its registered mark to eliminate the unconformity from its activities. Before 1985, the company's logo was the logo of RENAULT and CITROEN. But, after changing the SAIPA's production policies and extending its activities to produce various models of vehicles, an independent logo was mandatory to be prepared. After numerous studies of the respected and artful teacher, Mr. MOMAYEZ, who designed the logos of different companies such as Iranian National Airline Organization, Tehran Mu-

nicipality, and so on, the SAIPA's logo was designed by revealing of Iranian Traditional Masonry which has beautiful geometrical arrangement.

SAIPA Products:

- In 1968, production of different types of «Djian» Automotives.
- In 1975, production of different types of Renault automotives.
- In 1986, responsibility of producing NISSAN pick-ups, which transferred from ZAMYAD company to SAIPA.
- In 1991, production of Renault 21 automotives.
- In 1992, production of Pride automotives.
- In 1996, design and production of pride automotives.
- In 1996, design and production of the first Iranian made automotive under the name of «Caravan».
- In 1999, production of «Xantia».
- In 2001, design and production of SAIPA 141, automotives.
- In 2004, production of «RIO» automotives.
- In 2010, design and production of new platforms of SAIPA 111, 132, 141 and 131.



-	Introduction		1
-	Introducing vehicle and its equipment		2
-	Driving a vehicle		3
-	Driving facts		4
-	Technical emergencies		5
-	Bi-fuel (CNG)		6
-	Vehicle maintenance		7
-	Vehicle guarantee		8
-	Vehicle specifications		9



CHAPTER 1

- How to use the owner's manual
- Break-in period (Initial period of vehicle operation)

Introduction

1

Introduction

1

How to use the owner's manual

The main goal of this manual is providing a better and easier facility for operating the vehicle. This manual can be used as an auxiliary source in many cases.

It is recommended to read carefully all the contents of this manual to prevent from the injuries when driving and accidents by considering its cautions and warnings.

The figures shown in this manual help you operate the vehicle as best as possible.

It also notifies you the technical specifications, important safety points, and driving at different conditions. You have to read all the cautions, warnings, and recommendations mentioned in this manual and follow the recommendations and steps carefully.



Warning

The warning word implies the cases which cause injuries in different degrees and also lead to death.



Caution

The caution word implies the cases which cause serious injuries to the vehicle's passengers.



Attention

The attention word implies the cases which cause damage to the vehicle.



Environment and vehicle

What are the environmental issues that affect the environmental

Break in period

In break-in period (Initial period of vehicle's operation), there is no necessary special action to take. Only by taking into account several safety points and cautions in the first 1000 Km of operation period, you can improve the normal operational and economical conditions of your vehicle and increase its useful life. To do so, the following points must be considered:

- Do not overload the engine, when you are driving.
- Do not drive at a constant speed for a long time. By changing the speed, improve the engine sealing conditions.
- Except in emergency situations, do not take brake suddenly.
- When starting the engine and starting to drive the vehicle, do not push the accelerator pedal abnormally.



Environment and vehicle

The fiftieth principle of basic law

Protecting the environment that recent and future people should have a developing social life in it, is public duty in Islamic Republic of Iran. Therefore, the economic activities and the others, which involve with pollution of environment or irreversible damages, are forbidden.



CHAPTER 2

Introducing vehicle and its equipment

Controls	12
Anti-theft system.....	13
Remote control system performance.....	15
Door locks.....	17
Windows.....	19
Seats.....	20
Safety Belts.....	23
Baby seats.....	28
Correct usage of safety belts.....	32
Air bag.....	36
Engine Hood.....	42
Engine hood and Fuel tank door (filler lid).....	43
Fuel tank door.....	44
Steering wheel and vehicle horn.....	45
Mirrors.....	46
Interior equipment	48
Rear window defogger.....	53
Heating and air Ventilation.....	54



Controls

2

- 1- Glove box door
- 2- Font Passenger airbag
- 3-lighter
- 4-ashtray
- 5- air conditioning knobs
- 6- Shift lever
- 7- Clock
- 8- Audio system
- 9- windshield washer/wiper lever
- 10-Instrument panel
- 11-Horn
- 12-Driver airbag
- 13- steering wheel
- 14- turn signal lever
- 15- trunk lid opener lever
- 16- CNG button
- 17- rear windshield wiper button
- 18- front fog lamp button
- 19- rear window defogger button
- 20- Rear fog lamp button
- 21- tilt wheel lever
- 22- head lamps light level switch
- 23- air conditioning duct
- 24- speaker
- 25- Inactivating button of Front passenger airbag
- 26- Hand brake
- 27- rear passenger ashtray
- 28- engine hood opener lever

* According to the vehicle model

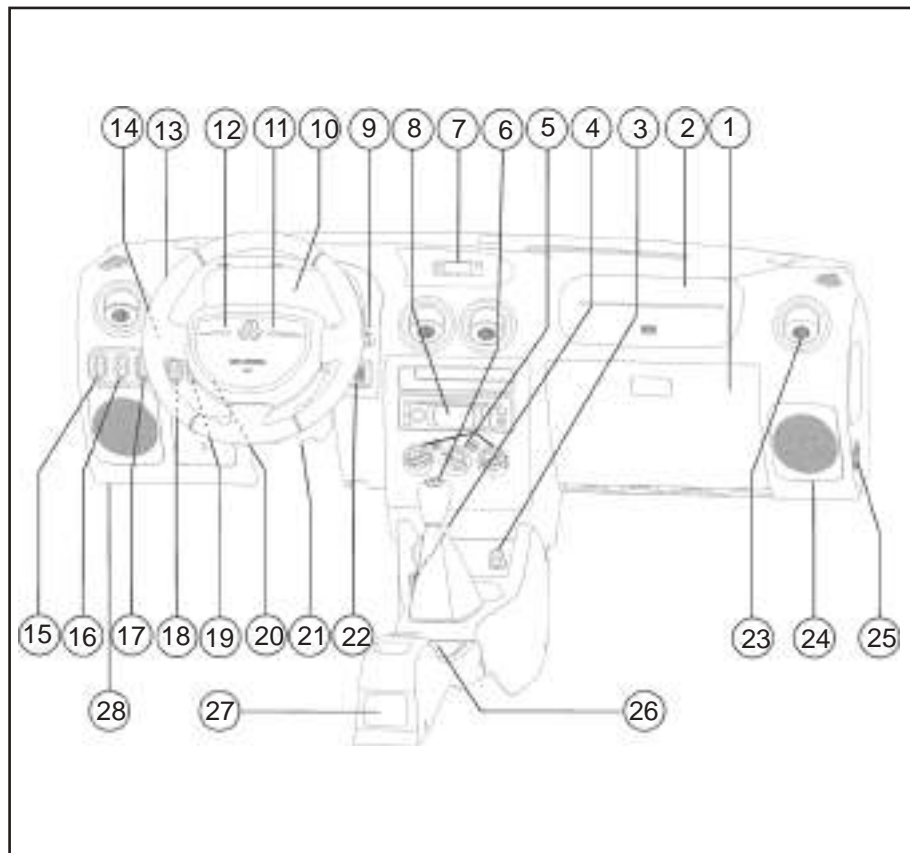

Anti-theft system (Immobilizer)

2



Your vehicle is equipped electronically with anti-theft system which prevents the theft possibility. This system works by an electronic transmitter which is installed on the ignition switch knob, communicates with the anti-theft system unit (ICU). If you insert the key into ignition switch and turn it to ON position, the anti-theft system receives signals from the switch transmitter and send them to the immobilizer control unit (ICU). It controls your switch code to see if it is correct to let the electronically controlled unit (ECU) ignite the engine.

Note

If you start the engine by another key unlike the main one (regular or undefined key to the system), the anti-theft system will not allow the engine to be ignited. In this case, the system will be locked for a minute, and then you can start the engine with the main key.

It is necessary to mention that the starting numbers by the undefined keys will extend progressively the waiting time of unlocking the system by the main key.

- Blinking of symbol , when the

switch is off, indicates that the anti-theft system (immobilizer) is active.

Note

- The electronic transmitter installed on the switch is one of the main components of the anti-theft system. Notice that the key should not be subjected to the temperature higher than 85 Celsius degrees, pressure, impact, or high electromagnetic field. This will cause malfunction of the switch and the system will not allow the engine to be started.

Anti-theft system (Immobilizer)

2



Note

When starting the engine, first turn the key into ON position and wait for a moment, then try to start.

Attention

This system does not affect doors opening and becomes active when starting the engine.

Note

In case of a key lost, consult the authorized agents of SAIPA YADAK Company for a new key programming to the system. It is necessary to mention that the spare key and its guarantee card are required to program or match a new key to the system. Therefore, it is important to be careful in safe protection of the spare key and its guarantee card.

Note

If change or unauthorized maintenance of the system causes any defect in different parts of the vehicle, the guarantee will not cover those defected parts.

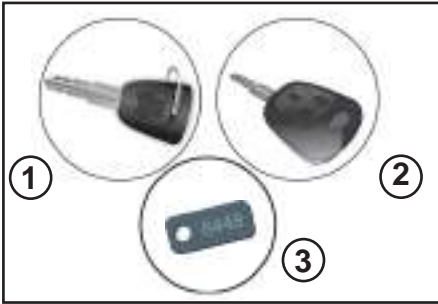

Keys

Your vehicle is supplied by the following keys:

- 1- A regular ignition key
- 2- An ignition key with remote control*
- 3- A tag of the key identification.

Remote control functions*



- 1- Locking and unlocking doors by remote control
- 2- Searching vehicle location
- 3- trunk lid opening key
- 4- Software locking key of remote control's keyboard

Caution

To prevent from the damage of the radio transmitter system inside the ignition key, do not subject it to humidity, high temperature, sun light, or impact.

Remote control

- 1- Locking and unlocking the doors by the remote control

By pushing the button  on the remote control, if the doors are locked, they will be unlocked by control unit's order. If the doors are opened, locking order will be sent via control unit by pushing the button  on the remote control.

Note

If one of the vehicle doors is left open, the locking signal by the remote control will not be effective. When the doors are locked and the unlock signal is sent by the remote control, the doors will be automatically locked, if vehicle's door were not opened within 15±2 seconds.

* According to the vehicle model

Remote Control Functions

2



2- Searching vehicle location

When the doors are locked, if the button is pressed  for two seconds, the flashers will blink 27 times at 3HZ frequency.

3- trunk lid opening

By pushing the stay damper button on remote control and holding it for 2 seconds, the trunk lid would be open.

4- Inactivating the software lock of the remote keypad

By pushing buttons  and  simultaneously for 5 seconds all remote functions will be inactivated , for activating them again the mentioned

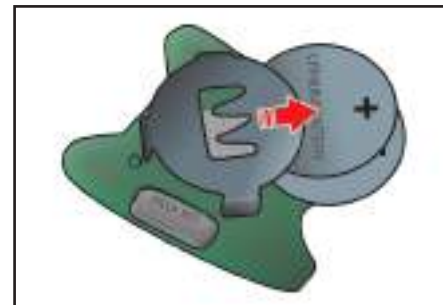

button should be held for 5 seconds.

Replacing the remote control's battery

If the indicator lamp on the remote control is off or is not blinking, it is required to replace the battery.

1- Use a screw driver to open the remote control's screw and remove the back cover.

2- As shown in the figure, take off the old battery and replace the new battery properly.

3- Replace the back cover and tighten the screw.

Caution

Use lithium lentiform battery of CR2016.

Warning

Do not use the old battery. The central locking system works by key if the remote control battery is dead. When replacing the battery, be careful not to damage or replace the anti-theft system electronic chip.



Locking and unlocking doors by key

- For locking and unlocking the central locking systems use the key. Put the key in driver's door and turn it left for locking and to right for unlocking.



Opening the trunk lid *

For opening the trunk lid, use the lever beside the driver's seat. Use remote control.



The trunk lid opener

This lever is on the left side of the driver's seat. Pull the lever up to open the trunk lid.

If you have to drive while the trunk lid is open, you should open the windows to lead the airstream.

* According to the vehicle model

Door Locks

2



Doors safety catches (child lock)

The child safety locks are located in the rear doors under the main key and they prevent from opening the doors from inside. To lock, push down the lever in the lock position and close the door. To open the door, first push up the latch key from inside and then open the door from outside.

Security points for preventing the vehicle's theft

Regard these points even when you are leaving the car just for a while:

- 1- Close the windows completely.
- 2- Pick up any valuable things with you or put them in the trunk.
- 3- Don't leave your key in the car.
- 4- Lock the steering wheel by turning it.
- 5- Lock all the doors.

In addition to these points, you can think of some ways to reduce the vehicle's theft possibility.

Beware:

- Don't park the car in lonely places.
- Don't park the car in dark places.
- Don't leave the car's documents in the car.

For more information, refer to police warnings on page 212.

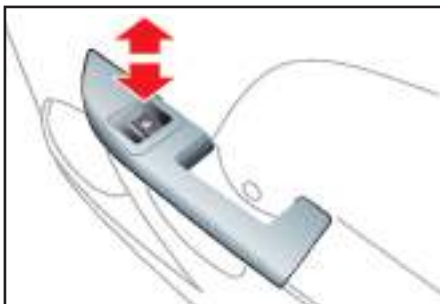

Power window switch on the front passenger's door

To open the window, push down the front part of button and to close it pull up the same part of button.

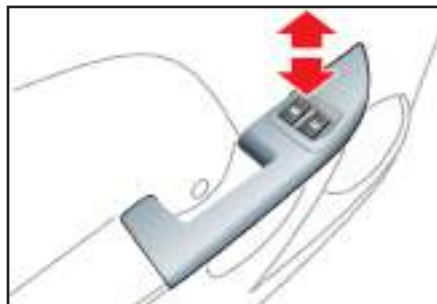

Power window switches on the driver's door

Using the power window buttons on the driver's door, the front windows can be controlled. To open/close the front door's windows, use the corresponding buttons as shown in the figure. The right button closes and opens the right window and the left one is related to the left window.

Warning

Prevent from the operation of the power windows buttons by the children. It may cause serious injuries.

Note

Water and cleaner's penetration into the power window buttons when washing the vehicle may damage their performance.

Seats

2

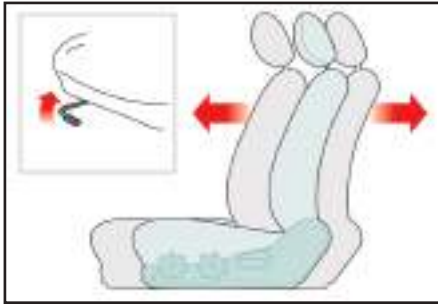

Front seat movement

To slide the seat back and front

- 1- Pull up and hold the adjustment lever that is under the front edge of the seat.
- 2- Move the seat at the desired amount.
- 3- Release the lever and ensure that the seat is locked at the desired position.

Warning

Do not adjust the driver seat and its cushion when driving. It can cause reduction of driving control, damages, and injuries.

Do not put on the seat anything that makes the position of the seat locking when occurring the accident and sudden brakes, which causes serious injuries and even death.

Always adjust the seatback in the vertical position and fasten the safety belt properly so that the belt crosses the lap.

If a child is seated on the front seat, put the seat cushion in a complete vertical position.



Front seats cushion adjustment

- 1- To adjust the front seat cushion angle, lean a little bit to the front and pull up the adjustment lever at outer part of the seat.
- 2- Adjust the seat cushion as desired.
- 3- Release the lever and ensure the seat cushion is fixed at the desired location (for locking the seat cushion, the corresponding adjustment lever must be set in the initial position).



Caution

Do not put anything under the front seats. This can cause improper movement of the seats or malfunction of pedals if they interfere with driver's feet.



Warning

To prevent from the side of the passenger seating on the front seat when vehicle is in motion, do not recline the seatbacks. In a reclined position, the seat belt cannot do its job properly and the passenger can slide in a crash and gets injury even death due to going the belt up over his abdomen.

Therefore, when vehicle is in motion, adjust the seatback in the normal vertical position.

Safety Belts

2

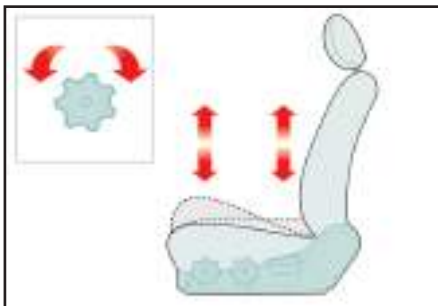

Adjustment of seat height *

- To adjust the seat height, turn the wheel located in the seat side.
- To lower the seat, turn the wheel counter clock-wise.
- To lift the seat, turn the wheel clock wise.

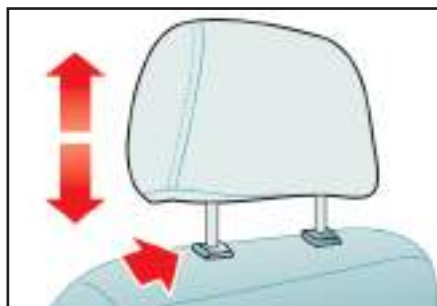

Adjustment of Head Rest

- To lift the head rest, pull it up. To lower the head rest push the left hand side button and lower it till the desired position.
- To remove the head rest, pull it up completely and push the button to detach.



Warning

- To prevent from the head and neck injuries, do not remove the head rest.
- When the vehicle is in motion, do not adjust the head rest.
- Adjust the head rest height at the same level of the ears to prevent from the injuries in a crash.

* According to car model.

Safety Belt Pretensioner (according to vehicle model)

Safety belt pretensioner's duty is to retract the safety belts so as the passenger is pulled to the seat and by this way the performance of safety belts improves. After locking safety belts, there is only a small movement for them and the forward movement of the passenger in a crash is restricted.

When the accident occurs or in the case of severe braking, safety belt holds the passenger tightly and prevents him from throwing out of the vehicle. This is why the usage of safety belts for passengers especially pregnant women is necessary.



Note

The pretensioner system becomes activated in the accidents even if there is no passenger seating on the seat. Activation of the pretensioner system occurs with a loud sound and the emission of smoke inside the vehicle. This smoke is not dangerous.

- Even so the smoke is not dangerous, it may cause skin allergy and is not smelled for a long time. Therefore, wash your face and hands after the accident.



Note

After 10 years of vehicle life, it is necessary to replace the driver and passenger airbag and pretensioner belt (if it is available).



Warning

To increase the proper function of the pretensioner system, the following points should be noticed:

- 1- It is necessary to buckle up the seat belt properly.
 - 2- The safety belt tab must be adjusted in its proper location.
- The pretensioner system of safety belt must be replaced after activation.
 - For safety, do not repair or replace the pretensioner system personally or by unauthorized person. In case, consult an authorized agent of SAIPA YADAK company.



Note

The pretensioner system of safety belts acts only in collides, which causes severe throwing out of the passenger.

* According to car model.

Safety Belts

2



Safety Belts guidance

- Set the backseat in the vertical position.
- Passengers must sit normally (no reclining or bending).
- The lap part of the safety belt must be set under the abdomen easily.
- The shoulder belt should go over the shoulder and across the chest.

The passengers should not sit as leaning forward.

To remind fastening the driver's seat belt, a warning light is installed .

Except the middle rear seat belt, other seats are equipped with the lap and shoulder belts (3 points). The middle rear seat belt has only lap belt which crosses under the abdomen (2 points).

The retractor lock of belt is not active in the normal driving condition; therefore, the belt is not tight in the slow motion of the passengers to provide their comfort ability. When braking, severe turning, and accidents, the re-

tractor lock of the safety belt will be locked automatically. Since the rear middle seat belt does not have retractor system, it is always in locked condition. This seat is the most suitable place to fix the child seat.

Warning

Be careful the belt tap is not twisted and trapped. If it does not release, consult the closet authorized SAIPA YADAK agent immediately.



Warning

After an accident, it is possible for the belt assembly to damage or lock. Therefore, after any accident, inspect the belt assembly, retractors, anchors and any damaged part. Consult an authorized SAIPA YADAK agent if it is required.

Warning

Inspect the belts periodically by pulling out the belt tap to see if there are any wearing, rupturing, burning, and other damages. Ensure the retrac-

tor system is working properly and the locks function is not improper. In case of any defect, replace the belt.

Warning

- Do not pass the belt through underneath or your arm and around your neck at all.
- Do not use a safety belt for two or more persons. It is designed for use of a single person.

Caution

When closing a door, be careful the belt tap is not trapped between the door and body. Because any damage to the belt tap and its lock system reduces the belt proper function.

Using the belt by pregnant women

Pregnant women are required to buckle up the safety seat belt except having special instructions from their doctors.

The lap belt must be fastened gently at the lowest part of abdomen. The pregnant women must be careful not to pass the belt over their abdomen.

Safety Belts

2



Using safety belt by children

- To protect the children at different ages, proper safety equipment must be used.
- Do not allow the children to stand or to kneel down on the seat when the vehicle is in motion.
- Do not use a single belt for two children or one adult with a child.



Warning

Do not allow the children to sit on your knees. In a crash, you will lose the control of your child.



Caution

The seats cover and the safety belts become hot in summer time and they can make injuries to your child. Therefore, before allowing the child to sit in his/her seat, check the seat cover, locks, and other metal parts in the child access area.

If by fastening the safety belt the shoulder belt hurts the child's neck or face, move him/her forward to the middle part of rear seat. If you cannot fix this problem, use the child seat.

Child safety system

- Shoulder belt must not pass over the neck and face of child.
- Improper use of the safety belt can cause serious injuries to the child.
- Based on the traffic regulations, it is safe to make the children sit on the rear seat. The children must be protected using a child seat and the safety seat belt.
- If the child seat is not installed properly, it is possible the child gets injured in an accident. Pay careful attention to buy a child seat which fits your car.

When installing the child seat, pay close attention to the manufacturer's comments.

Warning

-It is better to put the child seat on the rear, and whenever it is needed to put the child seat on the front seat, you should use the proper model and you should make inactive front seat air bags system*.

- When you do not use the child seat, put the child seat into the trunk or fix it firmly on the rear seat by the seat belt to protect it from shooting in a severe braking.

- If the child can use the safety seat belt, make him/her sit on the rear seat, do not let them sit on the front seat.

- When buckling up the safety belt, set the shoulder belt to go over the child's chest and the lap belt to pass over the lowest part of his/her abdomen. Moving the child to the middle

part of rear seat, make those adjustments possible. The shoulder belt must not go over the child's neck or face.

- If the safety seat belt cannot be adjustable at all, it is recommended to use auxiliary seat to lift up the surface of the child seat .

- Do not allow the child to stand or kneel down on the seat at all, when the vehicle is moving.

- When the vehicle is in motion, do not allow the child to sit on your laps. This will be dangerous in sudden brakes or in accidents.

- Allowing the child to sit on your knees does not protect him/her in the accidents even if the adult wears the safety seat belt.

Note

Before installing the child seat, read the manufacturer's instructions.

2

* According to car model.

Child Seat

2

Children protection

Do not assume children as adults with smaller bulk. The weight ratio of head to body weight ratio differs from adults up to 7 or 8 years old. In sudden acceleration reduction or impact, the head weight of child and weak muscle of his/her neck may cause serious injuries into the backbone. We can use the seat belt for children like adults, just when the child is 10 years old and he/she is as tall as 135cm.

That's why many countries have codified rules about the child's carrying instruments, selling and using safety equipment appropriate with the child weight.



Before 10 months old (less than 10kg weight)

The seat should be installed inverse, using belt with 3 connections, according to the picture.



From 9 months old to 3 years old (less than 18kg weight)

The seat should be installed as against, using belt with 2 or 3 connections, according to the picture.



Older than 3 years old (more than 15kg weight)

The seat belt regulator allows the child to sit on the rear seat easily while his/her face is straight forward. (Using belt with 2 or 3 connections)
(For children between 3 to 6 years old)



Older than 3 years old (more than 15kg weight)

We should use another fixing guard, which is installed on the rear, seat for children with bigger bulk. We must use belt with 3 connections and the child's face should be straight forward.
(For children between 6 to 10 years old)

 **Note**

It is necessary to use the child seat according to the country rules.

Child Seat

2



Fixing a child seat by a lap-shoulder belt

- 1- Replace the child seat in a desired position.
- 2- Pass the belt tab over the specified position shown in the Figure.



- 3- Pass the shoulder belt through the position specified by the manufacturer.



- 4- Lock the seat belt and check the looseness of the seat. Move the seat in different directions to ensure it is fixed firmly. If you want to tighten it more, unlock the belt and allow the retractor to function, to have more tightness.



Fixing a child seat by a lap belt

- 1- Replace the child seat in the middle part of rear seat.
- 2- Pull the lap belt latch.
- 3- Insert the tab of the belt through the position specified by the manufacturer of the child seat.

4- Lock the belt and ensure it is fixed firmly by pulling the belt tab to adjust. After installation, move the child seat in different directions to ensure it is fixed firmly.

The correct way of using the seat belt

2



Warning light of seat belt

The safety belt warning light turns on if the ignition switch is in ON position and the safety belt is not locked.



How to wear front seat belt properly

- 1- Pull the latch plate by hand.
- 2- Pull slowly the belt tab out of retractor.



- 3- Push the latch plate in to the buckle until it clicks.

The correct way of using the seat belt



4- Set the lap belt at the lowest part of your abdomen to prevent from sliding under the lap belt in a crash. Pull up the seat belt on the shoulder to keep the belt tight on your body.

The belt retractor automatically applies a pulling power on the belt tab, thus for safety do not allow the belt to get loose.



Safety belt releasing

To unlock the belt, push the button on the buckle.



Setting the front seats safety belts

Shoulder belt anchor height can be adjusted as desired. To adjust the height, pull the adjuster knob out and move the anchor up or down.

After adjustment, make sure the anchor is locked properly.

The correct way of using the seat belt

2



How to wear the rear safety belt properly (rear middle seat)

1- Pass the lap belt under your abdomen.

2- Push the latch plate in to the buckle until it clicks. Make sure the belt tab is not twisted.



3- To lengthen the belt tab, pull the latch plate at the proper angle.

4- To shorten the belt tab, pull the latch plate at the proper angle to set the desired length.



5- Pull the extra part of the belt such that the tab fits completely under your abdomen.

Caution

It is necessary to use the child seat according to the country rules.

Guides on the proper use of safety belts

To check the proper function of safety belts, the following points should be noticed:

- Always use the safety belt, even in short trips.
- If there is any torsion in the belt tab, smooth it before using.
- prevent from touching sharp and coarse objects with the belt tab, they will damage the tab.
- Regularly check the belt function in terms of retraction, anchors, locks, other parts, and any possible damages. In case of any damage, replace the damaged parts.
- To clean the belt tab, use the water and soap solution which can also be used in cleaning the seat covers.
- Do not apply detergent for cleaning the belts; this will reduce the retraction power.
- After unlocking the seat belt, pay attention to the belt to be retracted completely by the retractor.



Warning

Importance of safety belt use

There are four important reasons to use the safety belt and air bag.

- 1- To hold the passengers in a fixed condition and to prevent them from moving toward the air bag.
- 2- To protect the passengers in roll-overs, side and rear collisions in which the air bag is not installed.
- 3- To protect the passengers in minor front collisions in which the air bag does not deploy.
- 4- To prevent the passengers from shooting outside of the vehicle.

Safety Belt

2

Supplementary safety equipment-Air Bag Vehicle air bag duty*

The vehicle is equipped with a dual unit system as supplementary safety equipment. This consists of driver's air bag and front passenger's air bag. In some models, only driver's air bag is installed.

Air bag is used to increase the passenger's safety. It is necessary to mention that the air bag can not play the safety belt role.

Undeployment of air bag in some accidents

In many accidents such as side or rear impacts, rollovers, collisions of several vehicles, and collisions at low speeds, the air bag does not operate.

It deploys when the passenger moves toward the air bag from different sides.

Importance of safety belt usage

There are four important reasons for the use of safety belt and air bag.

- 1- To hold the passengers in a fixed condition and to prevent them from moving toward the air bag.
- 2- To protect the passengers in rollovers, side and rear collisions in which the air bag does not deploy.
- 3- To protect the passengers in minor front collisions in which the air bag does not deploy.
- 4- To prevent the passengers from shooting to the outside of the vehicle.



Warning

In the vehicles equipped with the air bags, buckling up the safety belts is mandatory for all the passengers. This will prevent serious injuries occurring during the accidents.

- The safety belt protects the driver from moving toward the air bag.
- The air bags inflate only in severe front accidents and it does not deploy in successive collisions of several vehicles.
- When trapping the vehicle in the flood (penetration of water into the vehicle), do not turn the ignition switch in ON position to unlock the steering wheel before disconnecting the battery. This may cause the air bag to inflate and the passengers get injury.

* Depending on the vehicle model

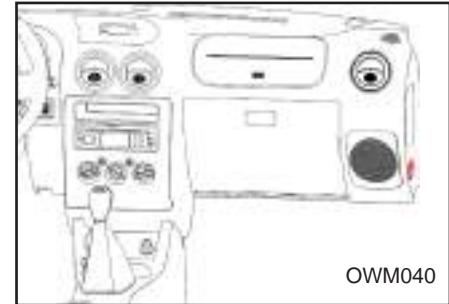
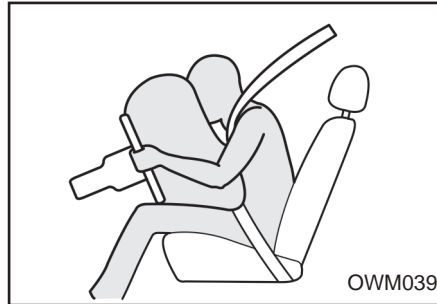
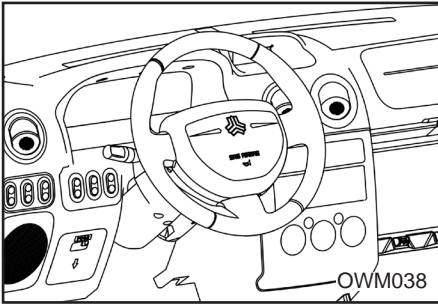

Air bag system components*

The main components of Supplemental Restraint System (SRS) of the vehicle are:

- The driver's frontal air bag is in the steering wheel and the right front passenger's air bag (if any) is located in the dashboard.
- A defect detector system checks constantly the system function.
- A warning light turns on when any defect is detected in the system.

* Depending on the vehicle model

- An emergency power of air bag functions in the accidents in which the vehicle electrical power is disconnected.

To check if the vehicle is equipped with the air bag system, you can see the "SRS" label on your steering wheel.

How the air bag works

The driver's frontal air bag is in the middle part of the steering wheel and the front passenger's frontal air bag is located in the upper part of the dashboard.

In frontal accident, the frontal air bags inflate to protect the passengers.

There is no sign which shows at what speed the air bag deploys. The function of the air bag in the Supplemental Restraint System (SRS) depends on the accident direction and its severity.

These two important factors determine when the signal of air bag actuation will be sent. Also, the air bag inflation depends on the vehicle speed, accident direction, vehicle strength, and the objects that the vehicle hits them.

The air bags inflate and deflate within 0,1 second.

Air bag

2

These two important parameters define sending the airbag inflation signal. In addition, airbags inflation depends on another parameters such as vehicle speed, collide angle, vehicle strength or the obstacles that the vehicles collide them. Airbags inflate and deplete in 0.1 seconds.

Therefore, it is impossible to see the inflation of the airbag. The first observation after the collision is the deployed airbag that is outside of its cover. It should be noted that airbag inflation could cause irritation, bruise and broken bones.

Airbag inflation could cause

dangerous injuries in some cases, especially when the driver adjusted the seat near the steering wheel.

In order to have more control, adjust the seat as far as possible to the steering wheel in the vehicles that are equipped with airbag. This prevents severe injuries or death in collisions.

Note

After 10 years of vehicle life, it is necessary to replace the driver and passenger airbag and pretensioner belt (if it is available).

Warning



Don't place the objects on the airbag cover or under it. Because after airbag inflation, the objects are thrown out and there is the possibility of injuries.

Warning

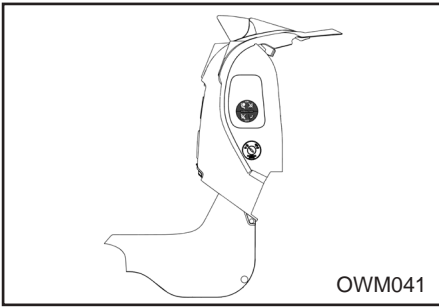
All the repairing or replacing of the harness, connectors and other parts that are related to the airbag and its control unit, should be done by SAIPA dealership. So, if there is any problem or malfunction in the ACU, resolving procedure would be done in the dealership.



How to make front passenger air bag inactivated

To fix the child seat on the front passenger seat (considering the standard and regulations), the front passenger air bag must be made inactivated. To do so, push lock button  and set it in OFF position by turning the  button while the engine is OFF. In this condition, the air bag warning light  stays ON continuously when turning the engine ON.



How to make activate front passenger air bag

After removing the child seat from the front passenger seat, reactivate the air bag with ON position lock 1 in the front passenger.

Warning lamp of inactivated airbag *

When the airbag inactivation switch  is in OFF position, this lamp remains ON.

Warning

Make sure that the air bag warning light  stays OFF when switch is ON.

Note

When the front passenger airbag is inactivated, the airbag warning lamp  remain ON continuously.

* Depending on the vehicle model

Air Bag

2

Noise and smoke

The inflation of the air bag is followed by a loud noise and emission of smoke. Therefore, after inflation of the air bags, breathing inside the vehicle will be very difficult due to the smoke and dust emitted by the air bag deployment.

It is recommended after accident and the air bags inflation to open the doors and windows immediately to provide breathing easily and comfortable environment.

Warning

After the air bags inflation, the steering wheel assembly and the dashboard become too hot due to explosion. Touching them may cause burning. Therefore, do not touch the internal parts of the air bags enclosures.

Importance of properly sitting on the seat

The frontal air bag of front passenger is bigger than the driver's frontal air bag and inflates with a large pressure. If the front passenger does not sit properly and does not fasten his/her belt, his/her severe injury or even death is very likely.

It is necessary that the front passenger seat is set at the rear most possible position.

Warning

Severe brakes in an accident will be very dangerous for a front passenger who does not fasten his belt. This may cause the front passenger to move forward to the frontal air bag which can inflate and cause injuries. Due to frontal air bag, do not use the child seat on the front seat at all. During air bag inflation, severe injuries of the child may occur.

Air bag warning light

The air bag warning light duty is to warn any defect in the Supplemental Restraint System (SRS). Inspect the system in the following situations:

- If the air bag warning light does not turn on when the ignition switch is in ON position.
- If the air bag warning light remains ON after starting the engine.
- When the vehicle is in motion, the air bag warning light stays ON or blinks.

Warning

- Do not make any changes in the steering wheel and other parts of Supplemental Restraint System.
- Do not make any changes in the harness. This may cause unexpected air bag inflation and injuries of the passengers or undeployment of the air bag on time.

The trained authorized personnel should replace the airbags systems after each inflation or 10 years of vehicle life.

Nevertheless performing all the precautions, injuring is possible for arms and body by airbag (because of position and nature of the system and person).

Never place your hands in the middle of the steering wheel during driving.

Be sure that the passenger does not place his foot on the dashboard during driving.

Engine Hood

2



Opening Engine hood

1- To open the engine hood, pull the opener handle under the dashboard located at the left hand side toward you.

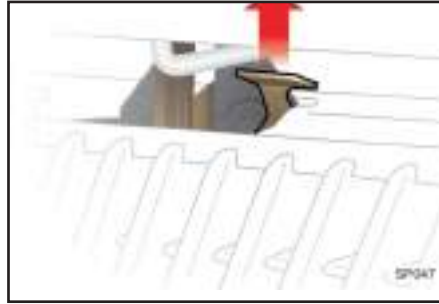

2- Go to the vehicle front and pull the engine hood up. Then release the secondary lever located at the middle bottom part of the engine hood as shown in the figure.

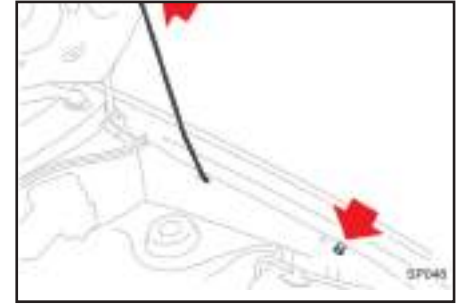

3- Raise the engine hood and put the retainer rod free end into the corresponding slot in the hood.

Engine Hood and Fuel Door

2

Closing Engine hood

- Before closing the engine hood insert the retainer rod into its retainer clamp in the hood to prevent from its looseness noise when the vehicle is in motion.
- Lower the engine hood gently and release it from the distance of 35 centimeters. After closing, lift the engine hood up to ensure it is completely locked.
- Do not close the engine hood severely.



Caution

Before closing the engine hood, pay attention all the parts are replaced, the tools removed from the inside engine compartment and the engine parts not left outside.

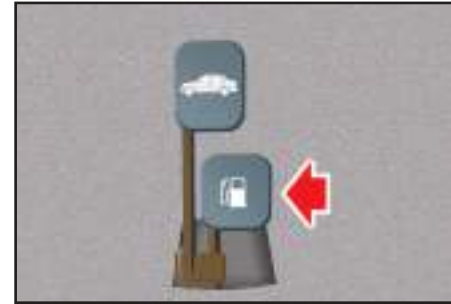

Opening Fuel door

Pull up the fuel door lever in the left corner of the driver's seat to open the fuel door.

Fuel Door

2



Opening fuel cap

- To open fuel cap, turn it counter-clockwise.

- To close fuel cap, turn it clock wise until it clicks, that means it have been closed correctly.

1- Fuel cap

2- Opening direction

3- Closing direction

Warning

Since it is possible the fuel tank to be pressurized, open the fuel cap gently with caution.

While there is a leakage of fuel from

the fuel cap or gas leakage noise, do not open the fuel cap until it finishes. Otherwise, there is a possibility of pressurized emission of gasoline vapor which will be very dangerous. Gasoline vapor is dangerous and flammable. Therefore, when fueling, turn the engine off and prevent from any spark, flame, and cigarette usage near the fuel tank filler neck. Always ensure that the fuel cap is properly and firmly closed.

Warning

If it is necessary to replace the fuel cap, be careful to use a standard cap. Using a non-standard cap in the vehicle results in malfunction in the fuel system and emission control.

If in a cold weather the fuel cap does not open easily due to icing, push the cap gently and by knocking slowly open it.

Prevent from spilling gasoline around the fuel cap and exterior surface of the vehicle. This will damage the painted surfaces.

Steering Wheel and Horn Assembly

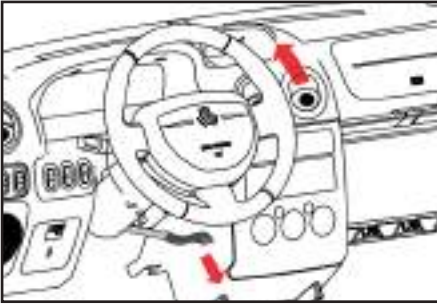

Adjust the steering wheel tilt angle at desired position before driving. To do so, first adjust your seat so that you can easily see the instrument panel on the dashboard front such as warning lights and indicators, and then adjust the steering at the desired position.

To change the tilt angle of the steering wheel, pull down the tilt adjuster lever located below the steering wheel. While holding the lever down, adjust the steering wheel tilt angle as desired and then pull up the lever. To ensure the steering wheel is locked, move up and down the steering wheel several times.

Warning

While driving do not adjust the steering wheel tilt angle. This is extremely dangerous.

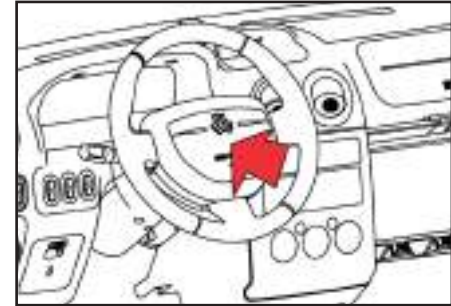

Horn

To sound the horn, push the centre pad area of the steering wheel on which the horn picture is depicted.

Mirrors

2

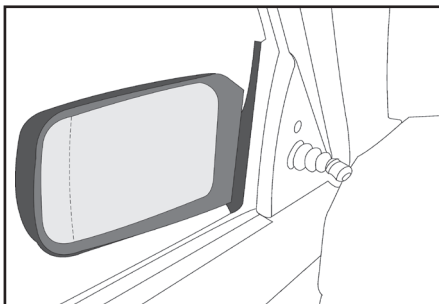

Side view mirrors

The vehicle is equipped with two side view mirrors, one in the left and the other in right hand side. These mirrors are adjustable by the corresponding levers. You can fold the mirrors in the rear direction to prevent them from damage when going through automatic car wash.

Mirror adjustment

To adjust the side view mirrors use the manual lever in the front of the front side windows frame as shown in the figure.

Caution

- The right side view mirror is convex and the objects are viewed closer than they appear.
- When changing the line, use the inside rear view mirror or look straight, to estimate your distance from the rear vehicle.

Note

Do not clean the ice on the mirror severely; this will damage the mirror surface. If the icing prevent from mirror adjustment, do not insist on adjusting by force. In this case, you can use special spray for ice melting or a piece of cloth or sponge soaked up warm water.

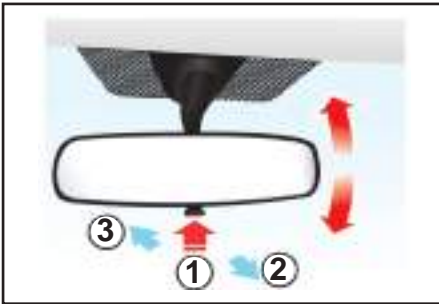

Inside view mirror (Front mirror) (day / night)

After adjusting the seat and steering wheel, adjust the mirrors so that you have enough vision from the rear window.

To reduce the reflection of other rear vehicle lights, pull the adjuster of rear view mirror toward yourself to set it in night position.

- 1- Day/ night adjuster lever
- 2- Night situation
- 3- Day situation

Caution

- Remember that setting the rear view mirror in the night position reduces the clear rear view.
- Be careful the objects on the rear seat do not blind your vision.

Interior Equipment

2



Room Lamp

Lamp room located in the middle part of ceiling can be set in one of the following three positions:

1- OFF: In this position the ceiling lamp stays off even if the vehicle door is open.

2- O: In this position the ceiling lamp turns on or off when the door is open or closes respectively.

3- ON: In this position ceiling lamp stays on even if the vehicle door is close.

Cigar lighter

To use cigar lighter push it all the way in and release it. When the element heats completely, the lighter pops back out by itself. If the engine is not started, you have to turn the ignition switch in ACC position to use the lighter.

Note

-Do not prevent from popping back out the lighter when it is heated.

-Use the standard cigare lighters. Using other non-standard equipment such as shavers, vacuum cleaners, and coffee makers may cause damage to the socket or disturb the electrical circuit of the vehicle.

-If the cigar lighter does not pop back out after thirty seconds by itself, pull it out manually to prevent from overheating.



Ashtray

The ashtray is displaceable and it can be installed in the rear or front part of the centre console. If you do not use the ashtray, you can use its place as cup holder.

Warning

- Do not use the ashtray as a garbage can.
- Hot cigarette and ignited matches put inside ashtray containing other flammable items may cause fire.



Rear seat ashtray

The rear ashtray is placed between 2 front seats on the centre console, to use the ashtray turn the marked place by pushing it toward you, as it is shown in the figure. Closing the rear ashtray is opposite of opening it.

Interior Equipment

2



Centre console

This part can be used as storage for holding small things or cups.

Warning

- Do not put the cups containing hot liquid without caps in to the cap holder when the vehicle is in motion.
- To prevent from damage when sudden brakes or accidents, do not put the bottle, and glass inside the cup holder or centre console when the vehicle is in motion.



Glove Box

To open the glove box door pull its handle toward yourself.

Caution

To prevent from damage in an accident or severe brake always close the glove box door when driving.



Sun visors

To use the sun visors pull them down. To use the sun visors for the side windows, pull them down first, take them out from their retainer brackets, and then turn them toward the windows.

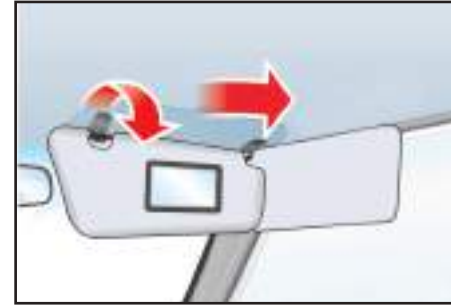

Sun visor mirror

To use the sun visor mirror, pull the sun visor down.

Interior Equipment

2



Digital Clock

When the ignition switch is in ON position, the digital watch buttons functions are as follows.

Hour

To change the hour shown on the digital watch display press the H button.

Minute

To change the minute on the digital watch display press the M button.

RESET

To remove the minute digits on the display, push the R button. After pushing the R button, the hour digit will be displayed.

For instance, by pushing the R button when the watch displays the time in the range of 9:01 until 9:29, it will display 9:00 and when it is in the range of 9:30 until 9:59 it will display 10:00.

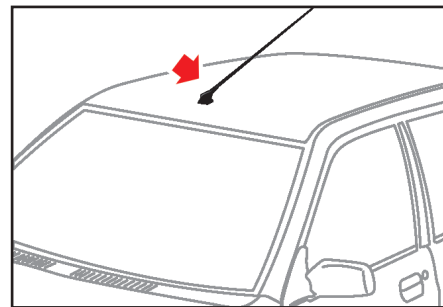

Antenna

The vehicle is equipped with the audio system which has an antenna. It can be moved up and down or removed when washing the car.

Caution

To prevent from damaging the antenna when washing the car, remove it from the vehicle.



Rear Window Defroster

Rear window defogger removes fog and frost from the surface of the rear glass, by making heat.

To use the rear window defogger turn the ignition switch in ON position.

The defogger light on the instrument panel stays on until the defogger is on.

If there is snow on the rear window glass, remove it gently.

Note

-Do not use sharp and coarse objects to remove snow from the rear window glass at all. This can damage the rear window defogger.

-To prevent from discharging the battery, use the rear defogger when the engine is running.

Heating and ventilation

2

1. Air flow distributor
2. Fan speed selector
3. Air recirculation controller
4. Temperature controller
5. Air conditioning switch





Fan speed selector

By turning this switch you can adjust the fan speed.
 Fan can be set in one of the following four conditions:

-  : The fan is OFF
- : Low speed
- : Medium speed
- : High speed



Temperature controller

You can adjust the temperature by turning this switch. For warm air turn it to right and for cold air turning it to left.



Air flow distributor

Air blows from different outlets, you can select the desired outlet by adjusting the air distribution switch.

Heating and ventilation

2



Air inlet control

By the inlet air control button, you can adjust the inlet air circulation method.

Air circulation inside the room

In this case the outside air is prevented from entering to the inside of the vehicle and only the inside air is circulated.

Outside air entrance

In this case, the fresh air enters from the outside.

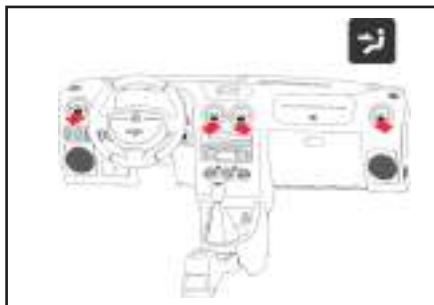

Valve position and outside air

1) Conditioning position

In this case, the air would directly blow into your face.

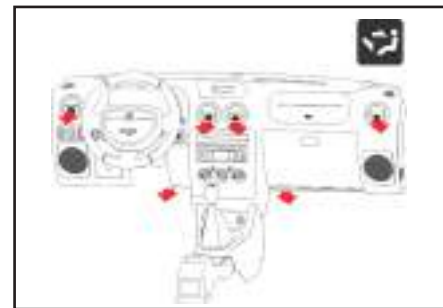

2) Both Positions

In this case, the air flows into your feet and face. Usually the air which blows into the feet is a bit warmer than the air blows into your face; except whenever the air control lever is in left side completely.

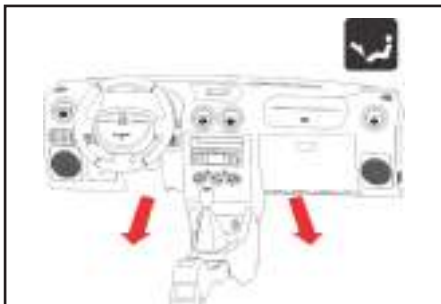

3) Under feet position

In this position, the air flows mainly toward floor and partially toward the windshield and the side windows.

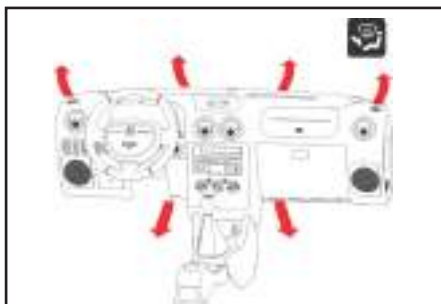

4) Underfeet and windshield position

In this position the warm air is blown mainly toward the windshield and the floor and partially toward the side windows.

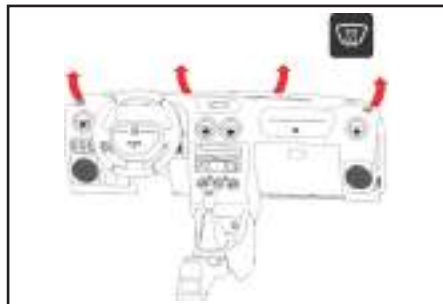

5) Windshield position

In this position most of the airflow is directed toward the windshield and a small amount toward the side windows and the floor.

Heating and ventilation

2



Air conditioner

For using the air conditioning system, push the button and hold it on one of 1 or 2 or 3 position. For turning off the air conditioning system push the button again.



Room ventilation procedure

Put the air control lever on the desired position as shown in the figure. Adjust the inlet air control lever on .

Put the air flow control lever on .

Put the blower speed switch on 1 position.

Note:

If the car had been parked directly exposing to sunlight, before turning on the air conditioning system, you should open the windows to send out the warm air.

For removing fog from the windows in rainy days you can use air conditioning to reduce the humidity from inside of the car.



Turning on the heater

1) Set the air temperature control lever in the desired position. (As shown in the picture)

2) set the inlet air control lever on 

3) set the air circulation lever on 

If the windshield surface is covered with fog, set the inlet air control switch on  button.

4) If you want to have dry and warm air inside the vehicle, turn on the air conditioning system.



Turning on the air conditioner

1) Set the air temperature control lever in the desired position. (As shown in the picture)

2) set the inlet air control lever on 

3) Turn on the engine and push  button.

4) Set the air circulation lever on 

5) Set the blower speed switch in the desired position.

Heating and ventilation

2



Note

If you want to have the maximum coolness of the refrigerant, set the air temperature control lever on the left side completely and set the inlet air control lever on . In addition, the blower speed control switch should be in the 3 position.

Clearing the windshield and side glasses condensation with the air conditioner

To remove fog and frost from the windshield and the side windows, you can use the air conditioning system as follows:

- 1- Set the air temperature control lever in desired position.
- 2- Set the inlet air control lever on 
- 3- Turn on the engine and then air conditioning system.
- 4- Set the air circulation and blower speed.

Caution

Using the air conditioning system while driving uphill and heavy traffic make the engine hot, so in these conditions turn off the refrigerant. Also do not turn on the refrigerant in high speed.



Warming up the windshield

1- Set the air temperature controller in the warmest position.

2- Put the inlet air control lever on 

3- Put the air flow control lever on 

Attention

If you need warm air on the floor put the air flow control lever on .

4- Position the fan speed switch to 1 or 2.

Position the air control lever on  to recycle the air inside the vehicle room.

Warning

When driving in too humid conditions use the  air conditioning system. Because of the difference between the outside air and the windows temperature, the windows surface would be covered with fog and the driver's vision would be blocked.



CHAPTER 3

Driving Vehicle

Ignition switch	64
Engine Starting up	65
Gear-Box	68
Brake system.....	70
Power steering	75
Front display indicators.....	76
Warning and indicators lights.....	78
Indicators and lamps.....	80
Rear fog lamp switch.....	82
Wiper and washer	83



Ignition Switch

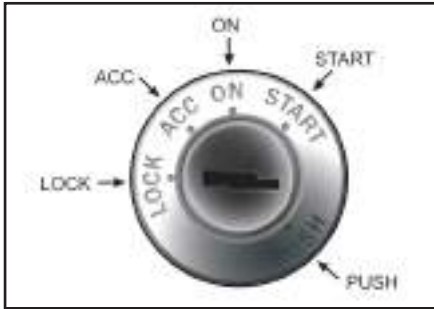

3

Starting switch

The descriptions of the positions on the switch (as illustrated in the figure) are as follows:

Lock position

In this position, the steering wheel is locked.

ACC Position

Some electrical equipment such as radio, clock and lighter can be used.

ON Position

At this position all the signs turn on and can be controlled.

Start position

Engine start state- Release the switch after the engine is turned on.

Push position

Push the key in and take out after the engine is turned off.

Important notes before starting up the engine:

- The parking brake lever should completely be pulled up.
- The change gear lever should be on neutral gear.
- Hold down the clutch pedal right down to stop the gearbox's gear from rotating when starting up the engine.

Start position

In the start position the engine will be started and by releasing the switch, it

will return in ON position.

If the ignition key is not turning in the lock cylinder, it is due to the force on the steering wheel. In this case, to release the steering wheel, turn it slightly to the left or right and then turn the key.

To set the switch in the lock position, push in the ignition key in ACC position while turning the key toward the lock position.

Caution

Hold the key on START position not more than 10 second. Wait minimum 10 second if restating is required. Release the key after engine started up.

Warning

- Never turn the key to LOCK or ACC position when driving. Never start the engine by putting your hand through the steering wheel.

Engine Starting up

1-Make sure the parking brake is engaged.

2-Hold the clutch pedal to the floor and shift the gear selector lever in neutral position. When starting the engine, push the clutch pedal all the way down.

3-Turn and hold the switch in the START position until the engine starts with in ten seconds.

In very cold weather when the temperature is lower than 18°C or when the engine has been off for several days, it is necessary to allow the engine warms up sufficiently. This must be done without pressing the accelerator pedal. To start the engine in warm or in cold condition, do not push the accelerator pedal.

Engine Starting up

3

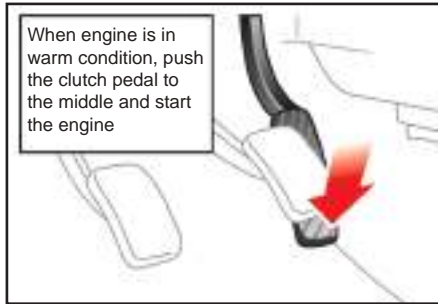

Starting engine in flooding

If the engine is not starting due to flooding with too much gasoline, do the following steps:

- 1- Make sure the parking brake is engaged.
- 2- Push the clutch and shift the selector lever in neutral position.

When starting the engine push down the clutch pedal

3- Push and hold all the way down the accelerator pedal.

4- While pushing all the way down the accelerator pedal start the engine and hold the ignition switch in the start position at most for ten seconds. If the engine starts, release the switch and the accelerator pedal quickly to prevent from sudden increase of the engine speed.

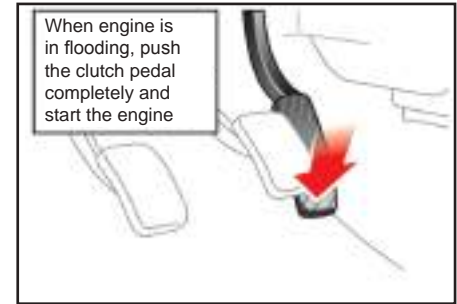

Starting Engine in warm condition

When the engine is warm and does not start normally (after several times, starting without pushing the accelerator pedal), do the following steps: Before starting again, wait for a minute and ensure that the parking brake is engaged.

- 1- Shift the selector lever in neutral position .When starting push the clutch pedal.
- 2- While pressing the accelerator pedal half way, start the engine (hold the ignition switch in the START position for ten seconds).
- 3- After starting the engine, wait for ten seconds to drive.



Note

Do not hold the switch in the START position for more than ten seconds. If the engine does not start or gets off, restart the engine after five to ten seconds.

Improper start of the engine may damage the engine.

Abnormal noise of the engine (from valves) may result from being it off for a long time.

This noise goes off after the engine temperature reaches the standard limit. Otherwise, consult an authorized SAIPA YADAK agent.

Manual Gearboxes

3



Gearbox operation

Shifting gears can be done as shown in the figure by five selections.

Push the clutch pedal all the way down and then shift the gear gently.

There is a safety system in the vehicle to prevent from unintentionally shifting from gear 5 to the reverse gear(R). In this case, the selector lever moves in to the neutral position and then in to the reverse selection.

Note

Only when the vehicle is in complete stop, shift the gear in to the reverse position.

To prevent the clutch system from early wear and abrasion, do not put your foot on the clutch pedal steadily.

Also, do not use the clutch pedal to stop the vehicle on the steep road (in traffic lights and so on.)

Warning

Before leaving the vehicle, make sure the parking brake is completely engaged, the engine is off, and the selector lever is shifted in gear 1 position. Otherwise, the vehicle may suddenly or unexpectedly move.

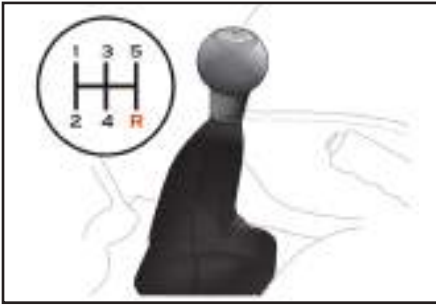

Changing gears

Changing gears are as shown in the fig.

Recommended speed at Gears:

Gear 1 to 2: 25Km/h
Gear 2 to 3: 40Km/h
Gear 3 to 4: 70Km/h
Gear 4 to 5: 100Km/h

Observation of the recommended speed increases engine and gear-boxes life time.

Reverse gearing

If you have to reduce your vehicle speed in a heavy traffic or on the steep roads, it is recommended to shift in to the lower gears before the engine becomes overloaded. The lower gear reduces the possible abnormal running of the engine, suitably accelerates the engine when increasing the speed.

Safety notes in driving

- Don't rest your hand on the gear change lever. The hand pressure will cause erosion on the gear change control system (mechanism).

- Don't rest your feet on the clutch's pedal. The feet weight will cause erosion on the clutch's system.

- Don't slip the clutch to stop the vehicle when driving downhill. The clutch slipping causes erosion on the clutch's system. Use parking brake to stop the vehicle on downhill.

- Don't drive in low gear for longtime. Driving in low gears for longtime causes excess fuel consumption and noises. In time changing gear from low to top gear will stop putting unnecessary load on the engine.

Brake System

Anti-lock Brake system (A.B.S)*

A.B.S system prevents each wheel from locking. This system contains 2 main parts: wheel speed sensor, and set of processor/modulator.

The advantage of this system is shortening the gap time between stopping and ordering the vehicle to stop. During the braking operation, the driver is not able to lead the vehicle because of locking of wheels, while a vehicle equipped with A.B.S does not lock the wheel, therefore the driver can lead the vehicle.

Some points for braking with the vehicle equipped with A.B.S:

1) Braking operation is done usually for the following purposes:

- Slow braking for controlling speed: here you are going to stop the vehicle slowly, for instance when you are going to take in or down a passenger. In this case the wheels usually are not locked and you can stop the vehicle by braking gently.

2) Emergency and severe braking: here you are going to reduce the speed quickly or stop the vehicle at the minimum distance, For instance when you confront with an object suddenly. In this case all or some of the wheels are locked and you should push your foot on the brake pedal steadily and also paying attention to the vehicle is managable. (Note that if the vehicle was drawn to margins because of changing line, the A.B.S system does not affect the vehicle control.)

Sometime while beating the brake pedal some inexperienced drivers think that the vehicle is getting trouble and they leave pushing the brake, while it is regular for cars using A.B.S.

* According to car model.

Significant points for Pride equipped with A.B.S:*

- 1) During activating the A.B.S you might hear sounds because of operating the valves and hydraulic pump. The sound in measure depends on the brake tension which developed on each wheel. This sound is normal and it is not due to a trouble in A.B.S.
- 2) After starting the engine and moving when the speed reached to 10km/h, the defect finder is activate and turns on the hydraulic pump to check the operation for a while. This may cause a sound produced by A.B.S and it is normal.
- 3) While braking normally you might hear sound produced by E.B.D system. This sound is normal and there is no need to change the A.B.S modulator.
- 4) After starting the engine, the A.B.S warning light stay on for 3 seconds and within this period the E.U.C system is checked if there is any defect.

* According to car model.

The warning light turns off when no defect is detected and stays on if any defect is detected. In case of any defect, consult an authorized SAIPA YADAK agent.

5) Pay attention that while the A.B.S is damaged the usual braking system is working normally.

6) The A.B.S increases the safety of the vehicle. Despite this, it is not a system for correcting the driver's mistake during driving or change the traffic situation. Therefore the driver should drive carefully and follow safety regulations and safe distance from the front vehicle.

7) If there were any problem with A.B.S function, consult an authorized SAIPA YADAK agent.

Brake System

3



Warning light of A.B.S:

-If the warning light of ABS stays on continuously, there is a defect in the A.B.S system circuit. In this case, the brakes function regularly without A.B.S system effect. You must consult an authorized agent of SAIPA YADAK.



Warning light for parking brake, brake grease level and E.B.D:

E.B.D system in PRAID is responsible for sharing the usual brake, which divides the brake power between front and rear wheel.

This light is turned on for 3 reasons:

- The park brake lever be pulled up or it had not been released completely. (Fault detection: release the park brake lever completely)
- Being down the brake oil level in main tank cylinder. (Fault detection: open the engine cab and then check the brake oil level on the tank cylinder and add brake oil if needed.)
- Having difficulties with E.D.B system (Fault detection: if none of the previous points detect the fault, the car E.B.D system does not work. Stop the car and call an authorized agent of SAIPA YADAK.

Problem sings in A.B.S

In case of each of the following problems you must consult to an authorized agent:

- Locking wheel and incomplete braking
- Wrong operation of E.B.D and A.B.S
- Increasing A.B.S operation
- Inactivating of the A.B.S (the warning light would turn on)

Brake system equipped with booster

The vehicle is equipped with a brake booster system which is activated when starting the engine. In cases such as turning off the engine at which the brake system does not function, you can stop the vehicle by pressing strongly on the brake pedal. In this case, the stopping distance will be longer. Pay attention to these notes: Be careful in towing the vehicle when the engine is off and the shift lever is in neutral position. If the engine turns off when you are driving for any reason, lead the vehi-

cle to the nearest appropriate position to stop. Do not apply brake when the engine is off, except in the emergency situations because by pressing the brake pedal the assisted force of the brake booster reduces.



Warning

If the engine is off, auxiliary braking system doesn't perform and there should be extra force on the pedal. In this case, the stopping distance will be longer. You should pay attention to the precautions before driving the vehicle.

Brake System

3

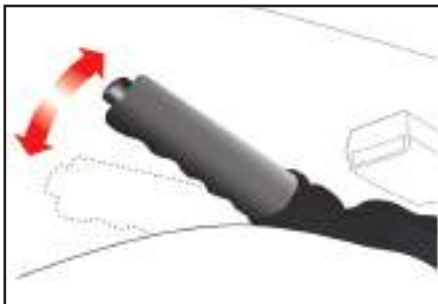

Parking Brake

To use parking brake, lift its lever up firmly while pushing the brake pedal.

Caution

While the parking brake is engaged do not drive. This causes early wear of rear brake pads.

To release the parking brake, first pull its lever up slightly, then push the end button and push down the lever gently.

Caution

Before leaving the driver's seat, always set the parking brake fully and then make sure the transaxle is shifted into 1st or reverse gear.

Always, after starting the engine, check the brake warning light. If the parking brake is not released completely, the warning light comes on. Therefore, before driving make sure the parking brake is released completely and the corresponding light is off.

If the warning light stays on after releasing the parking brake lever, there is possibility of the defect in parking brake system, and it should be taken in to account. In this case, stop the vehicle. Otherwise drive toward an authorized SAIPA YADAK agent with caution.

Power Steering*

Power steering uses engine power to provide better control of the vehicle.

When the engine is off or the power steering system is not working, you can steer the vehicle as regular but it will take much more effort.

If in normal engine condition the steering of the vehicle needs much more effort, consult an authorized SAIPA YADAK agent.



Note

-When the vehicle is stopped and the engine is still running, do not hold the steering wheel more than five seconds in a specific position (complete left or right turn position). This will damage hydraulic pump of steering.

-When the hydraulic system belt ruptures or the hydraulic pump does not work properly, you need much more effort to steer the vehicle. If the vehicle is parked for a long time in the cold weather (lower than 10°C), the viscosity of the power steering fluid will increase resulting in a delay for a short time in power system function. This is normal and you need to warm up the engine in idle condition.

*According to vehicle model

Instrument Panel

3



Instrument Panel

- 1-Speedometer
- 2- Engine temperature
- 3- Digital kilometer-counter and odometer
- 4- Odometer reset knob
- 5- Engine rpm
- 6- Fuel gage
- 7- High water temperature pointer
- 8- Fuel completion warning light

Fuel gage

Fuel gauge pointer returns to zero when the switch is on OFF position. Fuel gauge pointer shows the fuel level in the tank when the switch is turned on.

When the amount of fuel in the tank reaches at 7 liters, the warning light of the fuel turns on to warn that the fuel is about to finish. The fuel tank capacity is 37 liters.

Engine rpm

Tachometer indicates the engine speed in revolutions per minute (RPM). To prevent from engine damage, do not let the tachometer to remain in red area.

Speedometer

Speedometer indicates the vehicle speed in kilometer per hour.

Trip Odometer

Odometer indicates the distance traveled.

Trip Odometer reset knob

Press the reset knob to reset the odometer numbers.

Odometer

Odometer shows total vehicle traveled.



Instrument Panel

- 1-Speedometer
- 2- Engine temperature
- 3- Digital kilometer-counter and odometer
- 4- Odometer reset knob
- 5- Engine rpm
- 6- Fuel gage
- 7- High water temperature pointer
- 8- Fuel completion warning light

Fuel gage

Fuel gage pointer returns to zero when the switch is on OFF position. Fuel gage pointer shows the fuel level in the tank when the switch is turned on.

When the amount of fuel in the tank reaches at 7 liters, the warning light of the fuel turns on to warn that the fuel is about to finish. The fuel tank capacity is 37 liters.

Engine rpm

Tachometer indicates the engine speed in revolutions per minute (RPM). To prevent from engine damage, do not let the tachometer to remain in red area.

Speedometer

Speedometer indicates the vehicle speed in kilometer per hour.

Trip Odometer

Odometer indicates the distance traveled.

Trip Odometer reset knob

Press the reset knob to reset the odometer numbers.

Odometer

Odometer shows total vehicle traveled.

Pointers Warning Lights

Parking brake

Lights ON means either the parking brake is engaged or the brake fluid is in low level. When ignition switch is in ON position, put down parking brake lever completely to turn off the light.

Oil pressure gage

If this light turns on, it indicates that the engine oil pressure is low. If this light turns ON while driving, stop the vehicle and turn off the engine immediately and check the engine oil level. Top up the engine oil if the oil level is low. If the light stays on, consult the closest authorized SAIPA YADAK agent.

Note: *the light should turn on when switch is in ON position and turn off when the engine started up.*

Battery charge

Engine and/or electrical system has

* According to car model.

malfunction if this light comes on. Call to the nearest SAIPA YADAK Authorized Dealership if the light comes on with engine running, the electrical system function properly and the alternator belt is not torn.

Note

The light should turn on when switch is in "ON" position and turn off when the engine is started up.

Front lamp head light

This light comes on when switching to front lamp headlights

Rear window defogger

This light comes on when the rear defogger is active.

Hazard light

It flashes when the hazard light switch is turned on.

Fuel level light

This light comes on when the fuel quantity in the fuel tank is about 7 liter and it means the fuel will be finished soon.

Doors open light

This light comes on when the switch is in "ON" position and one of the doors is open.

Seat safety belt light

This light comes on when the switch is in "ON" position and stays on until the seat belt is fastened.

A.B.S warning light*

Constant A.B.S light on means A.B.S is not operating but the normal brake is operating. Please call the nearest SAIPA YADAK authorized agent for A.B.S troubleshooting.

Anti-theft system light

Anti-theft system is active when this light is flashing.

 **Rear Fog lamps indicator light**
This light comes on when the rear fog lamps become on.

 **Front Fog lamps indicators light***
This light turns on when the front fog lamps become on.

 **Check engine warning light**
This light is one of the problem detector components of the vehicle system.
If this light comes on while driving, there is a problem in the electrical system of the vehicle. In this case, the vehicle is able to move, but for inspection, consult an authorized SAIPA YADAK agent.

 **Caution**

- Driving for a long time while the check engine light is on will damage the vehicle and increase the fuel consumption.
- If the check engine light blinks, there is a possibility of defective catalyst which reduces the engine power.
- For inspection consult an authorized SAIPA YADAK agent.

 **Note**

Sometimes the check engine light comes on when the fuel tank cap is not properly installed. So in this case be sure about the fuel tank cap that is fully installed.

Pointers and Warning Lights

 **Airbag warning lamp:**
This lamp should blink 3 times by turning the ignition switch in ON position. During that, it controls the system. If there is any malfunction, the warning lamp remain ON continuously, else it becomes OFF. If the warning lamp blinks less than five times or it remains ON, there is malfunction in the system that you should refer to the nearest authorized dealership of SAIPA immediately. Because there is, malfunction in performance of airbag and can cause inactivation or delay in airbag inflation.

 **Inactivation-warning lamp of airbag:**
If the inactivation-warning lamp of airbag is in OFF position, this lamp remains OFF.

Lamps and Signs

3



Combination switch:

By twisting the combination switch lever as shown in the figure, instrument panel lights, license plate light, rear stop lamp and front parking light, turn on. Also, by twisting the lever again, in the same direction, headlamps turn on.



Headlamps upper beam:

When the dim lights are on, push the switch to the front to turn on the upper beam. The blue light on the speedometer comes on when the headlamps are on.



Flashing of the head-lamps

To use the signaling high-beam headlamps pull the control lamp toward yourself as shown in the figure and then release to return it to its initial position. When signaling by high-beam headlamps, it is not necessary to set the lamps in on position



Turn signal lamps

To turn on these lamps, as shown in the above figure, when turning right push up the control lever and turning left push down it. The signal lever includes two stages:

First stage-this stage is related to changing line and passing the vehicle in front of you.

Second stage-In this stage the lever moves completely when turning right and returns to its initial position in OFF step, by the complete rotation of the steering wheel.



Flasher light

Flasher light is used for drivers that are approaching or passing your vehicle. Also they use in towing or stopping the vehicle in the road side. If the flasher light turns on, rear and front turn signal lamps blink simultaneously.

Caution:

When the flasher lights are ON, turn signal lamps will not work solely.



Leveling Motor switch

This vehicle has a headlamps brightness adjuster thumbwheel set the brightness in a desired level and not to block the vision of the opposite vehicles drivers.

How to set the headlamps brightness
The headlamps brightness adjuster thumbwheel can be set in vertical direction according to the next table.

Head brightness adjustment

position	vehicle load		
	Front seats	Rear seats	Trunk
0	One or two persons	-	-
1	Two persons	-	Max. load
2	Two persons	one person	Max. load
3	Two persons	Two persons	Max. load

Rear and Front Fog Lamps

3



Front Fog Lamps*

To turn the front fog lights ON, turn the Daytime Running Lights ON and then depress the button shown on the figure.



Rear Fog Lamps

To turn the rear fog lights ON, turn the headlights ON and then depress the button shown on the figure.

Note

Using of fog lights is recommended in essential positions such as dust and fog. Using in other applications lead to hazards of rear drivers.

* According to car model.



Windshield Wipers

To set the wipers on, turn the ignition switch in on position and pull down the windshield lever as shown in the figure at desired positions explained below:

OFF- In this position the wipers off

INT - Automatic wipers condition

I - Low speed wipers Condition

II - High speed wipers Condition



Single Wiping Cycle

For a single wiping cycle, push the windshield lever as shown on the figure.

Caution

-To prevent from damaging the wipers arms, do not move them manually.

-To prevent from damaging the wipers blades, do not allow them to touch gasoline, Kerosene, and other oil-based Solutions.



Windshield Washer

To wash the windshield the ignition Switch must set in ON position, or you should start the engine. Pull toward yourself wind shield lever as shown in the figure and hold it at that position. In this condition the washing fluid will spray on the wind shield glass surface.

Caution

To prevent from damaging the washer Pump, be careful when the washer tank is empty do not operate the washer pump.



CHAPTER 4

Driving Points

- Required fuel specification.....	86
- Air pollution control system.....	87
- Recommendations before driving.....	88
- Comments on the economic usage of the vehicle.....	89
- Driving in special conditions.....	90
- Plaques and warning labels	94



Required Fuel Specification

Required Fuel Specification

The gas with EURO 4 standard is necessary for this vehicle. The vehicle has the best performance if the lead free gas is used. The lead free gas causes reduction of exhausted pollutions and prevents spark plug head sediment.

4

Note

Do not use the leaded gasoline at all. Using the leaded gasoline causes the catalyst to damage. Only use the additives authorized by SAIPA YADAK Company to clean the fuel system. The leaded fuel seriously damages the oxygen sensor of the engine and prevents from proper function of the pollution control system of the vehicle. Do not use the nonstandard additives.

* Pollution Control System

The catalyst system's type of this vehicle is CCC¹ connected to the exhaust manifold. Any change in the vehicle by the owner can affect vehicles performance, safety, and life, that may violate environmental pollution control regulations.

Furthermore, any damage or malfunction in the vehicle performance due to the changes by the customer is not covered by guaranty services.

Engine Precautionary measures

The exhaust gases contain carbon monoxide which is colorless and odorless and is very dangerous if it is smelled.

- Carbon monoxide is mixed by other exhaust gases inside the vehicle; consult the closest authorized SIAPA YADAK agent immediately. If you do not have access to the authorized SAIPA YADAK agent, do not drive with such a vehicle that has exhaust gas leakage in its room.

- Do not leave the vehicle when the

engine is on, while it is parked in the covered area at all. The maximum time period, the engine can stay on, in the covered area that is the time interval for starting and driving out.

- If you leave the vehicle in an open area when the engine is on, set the recirculation button in the fresh air position. If you smell any smoke, turn off the engine immediately.

- Do not sit inside the vehicle which is parked while the engine is on.



Environment and vehicle

If there is any abnormal smoke in the exhaust, please refer to the authorized workshops for diagnosis and engine repair, as soon as possible. The abnormal smoke makes more pollution of the air.

Catalyst Precautionary Measures

This vehicle is supplied with a catalyst pollution control system of the CCC type connected to the exhaust manifold. Consider the following precautionary measures:

- Only use unleaded gasoline.
- Does not drive or park on the flammable materials such as dry grass, paper, dry leaf, and so on at all. Because the catalyst is so hot and there is possibility of fire.
- If you see any malfunction in the engine performance such as the engine vibration or engine power reduction, stop driving the vehicle.
- Do not press the gas pedal for a long time while the vehicle is not moving.
- Do not change the engine parts and pollution control system.

All the changes and settings must be done by an authorized SAIPA YADAK agent.

If you do not follow the precautionary measures and the catalyst damages, the vehicle guarantee will be canceled.



Environment and vehicle

Catalyst

Most of the recent vehicles are equipped with Three – Way Catalytic Converter. The concept of three-way is the three basic pollutions that are produced by the engine, i.e., carbon monoxide, oxides of nitrogen and hydrocarbons, which are purged by these converters. The converters convert the pollution gases to carbon dioxide, nitrogen and water, which have less danger for the environment, by means of special elements.

It should be noted that in addition to the environment pollution, removing or replacing the catalyst lately, causes vehicle malfunction.



Environment and vehicle

This vehicle is equipped with the pollution control system via catalyst. In order to maintain and assurance of correct performance of the mentioned part, the following items should always be regarded.

The useful life of the catalyst in standard working condition is 100,000 km.

In the case of engine performance malfunction or reaching 100,000 km mileage, the mentioned part should be replaced in the authorized dealership of SAIPA.

Periodical inspections of exhausted gas should be done every 10,000 km. If the amount of pollution exceeds the standard value, replace the catalyst in the authorized dealership of SAIPA after making assurance about performance of the other parts.

Important Steps Before Driving

Before driving consider the following points:

- Make sure the windshields, rear window, mirrors, and lamps are clean.
- Check the tires conditions.
- Check the underneath of the vehicle to see if there is any leakage.
- Make sure there is no obstacle in the back while using the reverse gear.

Important Checks

Before driving the vehicle, check the engine oil level, radiator, brake fluid level, and the washer fluid level based on the suitable criteria. The detail procedure is written in the maintenance section.

Before start

- Make sure all the doors are closed and locked.
- Adjust your seat.
- Adjust the side view and rear view mirrors.
- Make sure all the lamps function properly.
- Check the instrument panel indicators.
- Set the ignition switch in ON position to ensure all the warning lights function properly.
- Release the parking brake lever completely and check if its warning lamp turns off.

For safety before driving make sure that you are familiar with all parts of the vehicle.

Driving after taking medicine

Driving after taking some medicines is very dangerous.

Make sure to consult your physician about driving after taking your medicine.



Environment and vehicle

Avoid unnecessary travels by personal vehicle, which has only one passenger.

Don't take extra load by the vehicle. Because every extra load increase the fuel consumption to the average of one liter per 100km.

Inspect the parking of your vehicle to be aware of fluid leakage timely

Comments on the optimal performance of the vehicle

The amount of fuel consumption depends on the driving method, and its time and place.

Use the following suggestions to reduce the fuel consumption of the vehicle and to reach its economical performance.

- Do not warm up the engine for a long time while the vehicle is stopped.
- Remember that when it is cold, the engine warms up within longer time.
- When you start to drive, accelerate the vehicle slowly.
- Make sure the engine is always tuned up, and follow the recommended periodic maintenance schedule to increase the life time of the vehicle parts.
- Do not use the air conditioning system if it is not necessary.
- When driving on the unsmooth roads reduce your speed.
- To increase the life time of tires and reducing fuel consumption, keep

them to the standard pressure.

- Maintain a safe distance from the front vehicle to prevent from sudden brakes and the wearing of brake pads and the tires. This reduces the fuel consumption when reaccelerating.
- Remove unnecessary loads from your vehicle.
- While driving do not put your foot on the brake pedal to rest. This will cause the brake pads to wear and the fuel consumption to increase.
- If the front wheels are not in the correct alignment, the tires will wear and the power will reduce, resulting in the fuel consumption increase.
- Being open of the windows at high speeds increases the fuel consumption.
- Opposite wind direction in driving increases fuel consumption. In this condition, it is better to drive at low speed.

Economic Usage of the Vehicle



Environment and vehicle

If you want to stop more than three minutes, stop the engine because in this case the fuel consumption is equal to one kilometer distance travelling.

Push the accelerator pedal up to mid to reach the desired velocity because full acceleration increases the fuel consumption immediately.

Using nonstandard parts such as exhaust manifold, which is a obstacle for the exhaust gases, makes malfunction in ignition and increases the fuel consumption rate.

Special Driving Conditions

Warning

- Never turn the engine OFF to coast down hills or anytime the vehicle is in motion. The power steering and power brakes will not function without the engine running. Instead, downshift to any appropriate gear for engine braking effect.

- If the vehicle gets stuck in snow, ice, or mud. You can use sand, salt tire chain or anything can increase the friction such as a blanket under the front wheels.

Warning

Using the reverse gear on the slippery roads is dangerous; this will cause sudden speed change of the wheels and their slide.

4

Special Driving Conditions

When hazardous driving is encountered because of water, snow, ice, mud, sand, or similar hazard, follow these suggestions:

- Drive cautiously and keep a safe distance from the front vehicle to increase the braking distance.
- Do not brake or turn suddenly.
- When driving in snow, mud, and sand, shift into the second gear and press down the accelerator pedal gently. This prevents from front wheels spinning. If it is necessary, you can use the first and the reverse gear.

How to free Your Vehicle when sticking in snow and mud

When the vehicle gets stuck in snow and mud, to free it repeatedly shift into the first and the reverse gears and press down the accelerator gently.

Do not press the accelerator pedal strongly. If you are not able to free your vehicle from snow or mud, you can use a towing vehicle to get out.

Otherwise, the engine and gear box will damage due to the higher engine temperature.

Warning

When starting to drive do not press the accelerator pedal strongly and do not release the clutch pedal suddenly. This will cause the front wheels to spin and the tires to become hot, which may result in explosion of tires and injuries of the people around the vehicle.

Driving at night

Since driving at night is more dangerous than day, consider the following recommendations:

- Driving vision at night especially on the streets without lights is reduced. Therefore, reduce your speed and keep a safe distance from the front vehicle.
- Adjust the mirrors so that to reduce the reflection of other vehicles lights.
- Keep always the headlamps clean. Otherwise, the driving vision at night will be reduced.
- Do not stare directly in to the approaching vehicles head-lamps. This

will reduce your vision and you need several seconds to readjust your eyes to the darkness.

- Turn on your headlamps so that your vehicle becomes visible to the approaching vehicles.

Driving in rain

Driving on wet and slippery roads is dangerous and it is required to prepare you for driving in rainy conditions. Therefore, notice the following recommendations.

- Make sure the wipers and windshield washer work properly.
- Drive slowly due to the vision reduction in heavy rainy weather and the need of larger braking distance when stopping the vehicle.
- If your tires are worn and do not have much tread left, applying your brakes on the slippery road causes your vehicle to slide and make an accident.
- Turn on your headlamps to make your vehicle visible to the approach-

ing vehicles.

- Driving too fast through water puddles reduces the brake performance. Therefore, slow down when driving through water puddles.
- If you feel your brakes are wet, drive slowly and apply your brakes several times to dry your brakes and to return them to their normal condition.

Driving in Special Conditions

Winter driving safety points

- The auxiliary tools such as tire chains, windshield washer fluid, a bag of sand, a flashlight, a small shovel, and a boost cable are recommended to have in your car while driving.
- Make sure you have enough amount of antifreeze in your radiator.
- Check your battery and its cables to be in good condition. The cold weather reduces the battery performance; therefore, it is better to use a good quality battery during winter time to have a better starter performance.
- Check the spark system if there is any disconnection or damage.
- Use proper antifreeze windshield washer fluid and make sure there is enough amount of the fluid inside the washer tank (do not use antifreeze coolant in your washer tank).
- Does not use the parking brake if you feel the possibility of freezing. This happens after driving in snow and rain and the temperature drops below the freezing point. In this case

use the first and the reverse gear instead of parking brake. And use proper obstacle for rear tires.

Winter Tires

It is recommended to use winter tires on all four wheels. Otherwise, the vehicle driving control will be difficult. When using winter tires, the vehicle speed must not exceed 120 km/h.

Tire chain

Tire chain selection

Using the tire chain must be based on the traffic regulations. The tire chain must be suitable for the tire size. In regard, follow the manufacturer's recommendation.

Installing tire chain

Follow the manufacturer's instructions for tire chain installation.

The tire chain scratches the hubcaps, therefore before installing the tire chain remove them.



Warning

- The tire chain affects your vehicle driving control.
 - When using the tire chain, the vehicle speed must not exceed 50 km/hr or the value recommended by the manufacturer if it is lower.
 - Drive with caution and not on the puddles, pits, sharp curves, or other surfaces which cause vehicle jumping if possible.
 - Do not apply brake and change your direction suddenly.
- Use tire chains on your front wheels and readjust them every a half or one kilometer driving.

Driving in Special Conditions

Driving in watery areas

When driving in the watery areas, make sure the water level is lower than the wheel hubs.

Drive slowly due to the wet brakes and the need to larger braking distance. After driving in watery region apply your brakes several times while driving slowly to restore your brakes to their normal condition.

Plaques and warning labels

4

Starting up the radiator for cooling the pistons

Model number: Saipa 13011, 13013M
 Engine displacement: 1301 cc - water-cooled
 Engine type: Diesel
 Max speed: 120 km/h
 Fuel consumption: 18 l/100 km
 Net power: 40 kW
 Net torque: 10.7 Nm @ 1700

Notes:
 1. It will automatically adjust the speed when oil level is low (oil level gauge light is on) until the level is normal.
 2. Normal level between 'LOW' and 'FULL' when engine is cold.
 3. Ethyl glycol antifreeze must be used in aluminum engine block.
 4. Manual book must be used as reference for draining and refilling.

(Hydraulic Power Steering)
 Appropriate lubricant oil used in hydraulic power steering: 1-DEKRON II 2-PSF-III
 Hydraulic Power Steering oil capacity: approximately 675cc
 Note:
 The hydraulic oil level can be measured while the engine is off. The correct oil level on the gauge should be read between L,H. Please refer to manual handbook for changing the hydraulic oil. The hydraulic power steering shall not function when engine is off.
 Never hold the steering wheel to the complete left or right more than 5 second while the engine is on.
 Call to nearest Saipa Company authorized dealership for troubleshooting of the hydraulic power steering.

CAUTION

AIR CONDITIONER
 MAX. OPERATING CHARGE
 R 134a (11.1-200g) OR R-134a is
 allowed. DO NOT EXCEED. See
 CAUTION. 9.00 is total lower high
 pressure system. Do not overcharge by
 a certified technician. Some improper
 service methods may cause injury
 without service technician.

LUBRICANT

13011/13013M

Engine	Oil	Capacity
13011	13011	675cc
13013M	13013M	675cc

Gear box

Caution

- Don't open the radiator top when engine is warm.
- The cooling fluid in the expansion tank must be controlled at least once a month.
- (Normal level between 'LOW and FULL' when engine is cold)
- Ethyl glycol antifreeze must be used in aluminum engine block.
- Manual book must be used as reference for draining and refilling.

Warning:
 Call to nearest Saipa Company authorized dealership for any repair on bifuel vehicle.

The air pressure (cold condition)	
Front	Rear
2.0 bar (29.0 PSI)	1.8 bar (26.1 PSI)

Maximum load: 1500 kg (3307 lb)

The air pressure (cold condition)	
Front	Rear
2.0 bar (29.0 PSI)	1.8 bar (26.1 PSI)

Maximum load: 1500 kg (3307 lb)

Caution

Warning
 Mind your hand
 The fan may operate
 when engine off

Caution
 Pressurized liquid
 Don't open when warm
 Control container
 fluid level



CHAPTER 5

Warning equipment	98
Engine overheat	99
Emergency starting of the vehicle	100
Protection of electric circuits	103
Fuses	105
Towing	107
Replacing tires	109



Warning Equipment



5

Flasher

Flasher is used to warn the vehicles approaching or passing you to make precautionary measures. When emergency services or stop off the road, it is necessary to use the flasher. So that the signal lamp of rear and front goes on and off simultaneously.



Note

- When the flasher is on, the turning signals do not function.

Warning triangle

In the emergency situations at which the vehicle is stopped on the road, put the warning triangle on the road to warn the vehicles approaching you.

Engine Overheating

If the engine temperature pointer shows a high temperature, or the engine power is reduced or if you hear a loud knocking noise from the engine and it is likely the engine is overheated.

In this case, do based on the following instructions:

1- Turn on the flashers and stop the vehicle in a safe place, shift the gear into neutral, and apply parking brake.

2- Ensure that the A/C system is off.

3- If the coolant or vapor comes from the radiator, turn off the engine and set the ignition switch in ON position but don't ignite the engine. In this case fan starts working automatically. If the fan does not work, consult an authorized SAIPA YADAK agent.

If there is coolant leakage from the radiator, let the engine run in the idle condition, open the engine hood, and wait until the engine returns to its normal temperature.

If the engine temperature does not

decrease, turn off the engine until it becomes cool.

4- Check the coolant level inside the tank, if the level is low, check if there is any leakage from the cap of the radiator, hoses, water pump, and fittings of the radiator or heater. In case of serious leakage or another defect that can overheat the engine, do not turn the engine ON until removing the fault by an authorized SAIPA YADAK agent. If you did not find any leakage, pour some liquid into the tank cautiously.



Warning

When warning up the engine, do not open the cap of radiator, otherwise, hot sprays put and can damage you seriously.

If the engine overheats continuously, check the coolant system and repair its defects.

Starting Engine in Emergency Situations

Using a booster battery

Improperly using a booster battery can be dangerous.

Therefore, to prevent from damaging yourself, the vehicle and battery, perform the battery jump based on the instructions written in this manual.

If you do not know the proper procedure of jumping the battery, consult an expert mechanic technician or a mobile repair unit.



Only use a 12-volt booster battery. Otherwise, using a 24-volt battery (two 12- volt batteries in series or a 24-volt generator) can damage the starter, sparking system, and other electrical elements.



- Keep the battery away from any spark or flame.

In the normal conditions the battery produces hydrogen gas which explodes in the vicinity of flame or spark.

When the dead battery is frozen or its electrolyte level is low, do not use battery jump. This can make an explosion.

Starting Engine in Emergency Situations

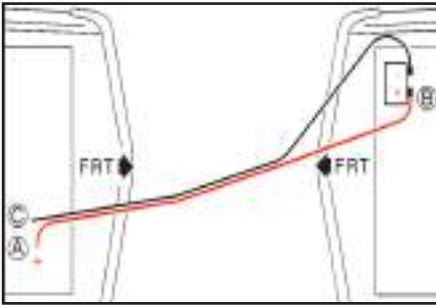

Battery jump procedure

- 1- Make sure that battery is 12- volt and its negative is grounded.
- 2- Check the electrolyte level of each cell of the battery.
- 3- If you are using another vehicle battery as a booster battery, make sure the two vehicles do not touch each other.

The corresponding parts are as follows:

- A- The dead battery
- B- The booster battery
- C- The metal and uncoloured part of the trunk

Emergency Starting

Booster cables connections

Connect the booster cables in the order of numbers indicated in the figure and disconnect in the reverse order.

1- Turn off all the unnecessary electrical equipment of the vehicle.

2- Connect the cables exactly in the order shown in the figure. First connect the one end of the first cable to the positive terminal (+) of the dead battery (1) and the other end of the cable to the positive terminal of the booster battery (2). Then connect the one end of the second cable to the negative terminal of the booster battery (3) and the other end to the fixed metal point of the vehicle (like bracket engine mounting or any uncolored surface) with the dead battery. Be careful the ground connection to become far from the dead battery.

Make sure not to connect the negative terminal of the booster battery to the negative terminal of the dead battery. Be careful the cables end to be connected to the proper points.

Do not lean to the battery when connecting the cables.

3- First turn on the engine of the vehicle with the booster battery and increase its engine rpm up to 2000, then start the engine of the vehicle with the dead battery.

If the discharged battery cause is not know (other than staying on the lamps while the engine is off) , it is necessary the vehicle to be checked by an authorized SIAPA YADAK agent.

Starting the vehicle by pushing

Starting the vehicle by pushing may cause damage to the emission control system.



Caution

Do not start the engine by towing the vehicle. Because the sudden motion of the vehicle toward front when starting can cause the collision of the two vehicles to each other.

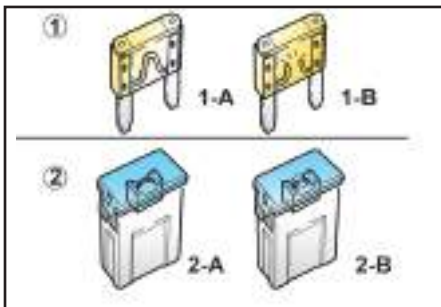

1-Regular fuse

1-A-Okay
1-B-Melted

2-Main fuse

2-A- Okay
2-B- Melted

Fuses

Fuses are simple connectors which disconnects the current when over current occurs to protect the electrical equipment from damage.

This vehicle has two fuse blocks, one inside the passenger compartment at the left hand side of the driver (lower part of the dashboard) and the other one inside the engine compartment near the battery.

The table of the fuses inside these two blocks will be indicated in this section.

If any parts of lighting system, auxiliary equipment, or control units do not function, check the fuse of the corresponding circuit.

Notice that if any fuse breaks, its band metal melts and it has to be replaced with a new one of the identical size and rating.

If the new fuse breaks again, it indicates that there is a problem in the electrical system of the vehicle. Therefore, do not use that electrical system and consult an authorized SAIPA YADAK agent as soon as possible.

Protection of Electrical Circuits

Warning

- Only use a new fuse with the identical capacity and rating when replacing a broken fuse.
- Using a high rating fuse can cause damage and even fire.

Warning

- Note that do not use a wire as a fuse even temporarily. This can damage the electrical system or cause fire.
- If one of the electrical systems of the vehicle does not function, first check the fuse block inside the vehicle at the left hand side of the driver(see the figure).

For fuse replacement do the following steps:

- 1- Set the ignition switch in off position and open the fuse block cover.
- 2- Using the caliper inside the fuse block, pull out the defected fuse directly and gently.
- 3- If the fuse is melted, replace it.
- 4- Use a new fuse with the same capacity and rating to replace the melted fuse. Be sure the fuse is firmly set in its proper place.

If you realized that the fuse cannot be fixed in its place firmly, consult an authorized SIAPA YADAK company agent.

If you do not have a spare fuse, you can use one of the other fuses which are not necessary for starting the vehicle (such as lighter or radio cassette player fuse).

If the fuses inside the vehicle are okay, but the headlamps or other electrical system elements are not functioning, check the fuse block inside the engine compartment and re-

place the broken fuse.

To replace the fuse do the following steps:

- 1- Turn off the ignition switch and all the electrical equipments.
- 2- Open the fuse block cover. (inside the engine compartment)
- 3- Check the fuses and replace the melted fuse with a new fuse of the same capacity.

Fuses

The fuse box is fitted to the left of the steering wheel. Open the fuse box cover to have access to the fuses. The fuses are simple connections which will disconnect the electricity current to stop damages to the electric equipments i.e. protect them. If equipment is not operating its relevant fuses could be disconnected.

Fuses replacement

- 1- Turn off the switch and all the electric equipments.
- 2- Open the fuse box cover and find the defected fuse by using the guideline table.
- 3-Take out the fuse puller and remove the defected fuse with it. The defected fuses are recognizable by their disconnected wire.
- 4- Substitute the defected fuse with similar or lower voltage fuse. The fuse box is contained with two spare fuses.



Warning

Nonstandard fuses must not be used even for a short time. nonstandard fuses will damage the wiring and electric equipment and cause fire.

Warning

- Substitute the defected fuse with similar fuse.
- Fitting in upper voltage fuse may cause damage or fire.
- Note that do not use a wire as a fuse even temporarily. This can damage the electrical system or cause fire.

Fuses

Fuse box table divided to user, capacity and color

A	CNG		10	Gas system	Red
B	Screen wiper		15	Screen wiper and washer	Blue
C	Fog lamp		20	Fog lamps	Yellow
D	Cooling fan		40	Engine cooling fan	Orange
E	Blower	All models	20	Cooling fan-Ventilator	Yellow
	Heater	New fuel injection	15	Ventilator - Heater	Blue
F	Power window		20	Power window switch	Green
G	engine	New slemens fuel injection	10	Alternator	Red
		fuel injection	5	Alternator	
		All models	10	Alternator and fuel pump	
H	Gauges		10	Gauges and thermometer, warning lamp and signal lamp	Red
I	Rear defroster		15	Rear windshield defroster	Blue
J	Stop		15	Horn and rear stop lamp	Blue
K	Hazard		15	Hazard lamps - clock and lamps	Blue
L	Room		10	Audio system, lamps-Interior lamps-Trunk lamps	Red
M	Hazard lamp		15	Front signal lamp, hazard lamp-license plate lamp-park lamps	Blue
N	EGI fuse*		10	ECU (fuel injection vehicle)	Red
O	Cigarette lighter		15	Cigarette lighter, clock, power antenna	Blue
P	Central lock		30	Central lock	Green
Q	Spare fuses				

* Improved injection system model

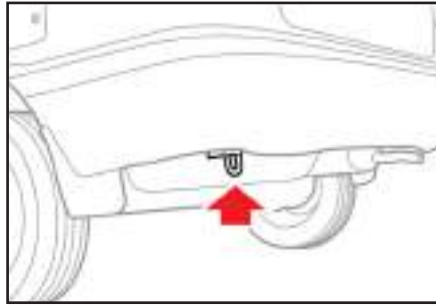
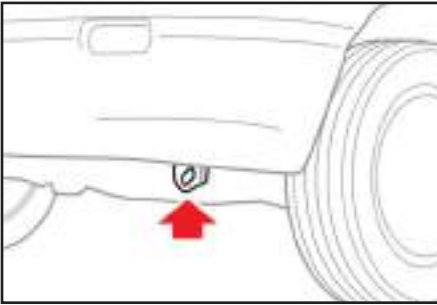

Towing the vehicle

If emergency towing is necessary, we recommend having it done by an Authorized SAIPA YADAK or a competent tow-truck service. Proper lifting and towing procedures are necessary to prevent damage to the vehicle. State and local laws applicable to towing vehicles must be followed.

As a general rule, towed vehicles should be pulled with the driving wheels off the ground. If the vehicle is seriously damaged and it cannot be towed properly use a flat bed for front wheels.

Front and rear towing hook

Use the hooks in order to vehicle holding only for towing the vehicle.

Vehicle Transporting

Transport by a truck

Carrying a vehicle by a truck is recommended to prevent from an accident and any damage.

Towing from the rear end

If it is possible do not tow a vehicle as suspended on its front wheels. If there is no choice, tow the vehicle for short distance at the lowest speed of the vehicle. The steering wheel must be locked when the direction of the wheels is set in a complete straight – ahead position. To maintain the straight – ahead position, you can clamp the steering wheel with a clamping device designed for towing.

Towing from the front end

The steering wheel must be locked when they are in a complete straight position. You can also clamp the steering wheel with a clamping device.

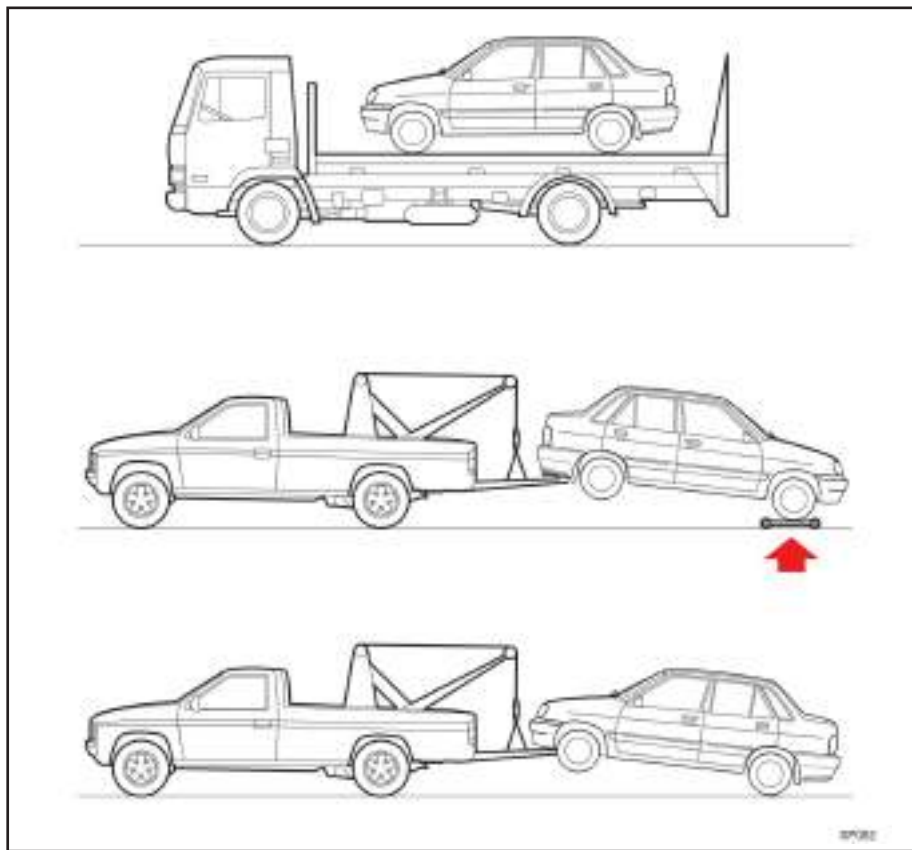

Tires Change



Spare tire and tire changing tools

Take out the jack, wheel wrench, and jack wrench from the trunk blanket underneath as shown.

You can fix the retentive pillar jack by turning the jack screw with hand.

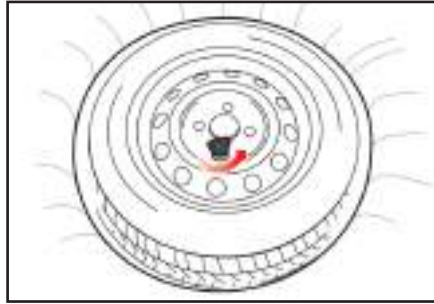

Spare tire

To take out the spare open the holding screw of the spare tire by turning it clockwise.

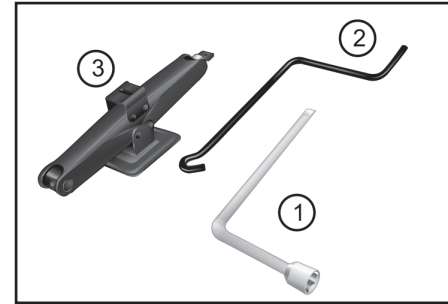

Tools

- 1- Wheel wrench
- 2- Jack wrench
- 3- Jack

Tires Change

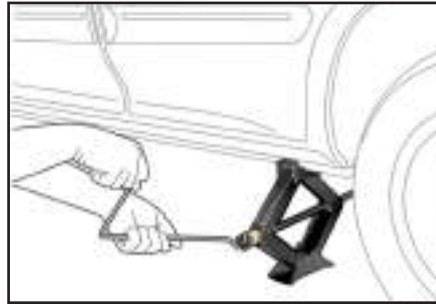
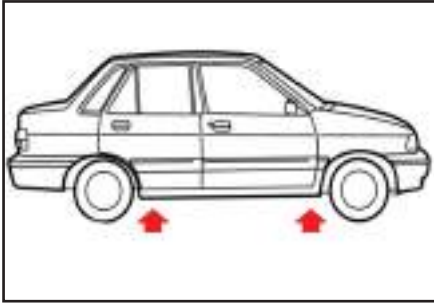

5

Jacking location under the vehicle

Locate the jack at the jacking positions indicated at the both sides of the vehicle near the tire to be replaced.

Make sure the jack is located on a smooth and horizontal surface.

Do not use the jack while there is a passenger inside the vehicle.

Make sure that the front wheels are completely straight head.

Apply the parking brake and shift into the first gear.

Jacking under the vehicle

1- Loosen the wheel nuts by wheel wrench.

2- Using the jack raise the vehicle far enough off the ground so that the tire detaches from the ground.

3- Remove the wheel nuts and take off the tire.

4- Replace the flat tire with the spare and tighten the wheel nuts manually as far as you can.

5- Lower the jack and remove it from the underneath of the vehicle.

6- Tighten firmly all the wheel nuts in a crisscross sequence.

7- Place the tools inside its box and the tire in its proper location inside the trunk.

Warning

- To replace the tire and repair pull the vehicle completely off road.
- If you are not able to replace the flat tire, get a mobile serviceman to help.
- Do not overload the jack
- For jacking use the specified locations. Be careful do not use other locations such as bumper underneath for jacking (instead of specified locations).
- When you have raised the vehicle using jack, do not get under the vehicle. Be careful do not get any part of your body under the vehicle.
- When jacking the vehicle do not start the engine.
- To prevent from any damage or dangerous only use the jack inside this vehicle, in the specified jacking locations.

Warning

Changing front tiers
When jacking under one of the front wheels using the proper location of the jack, shifting into the gear doesn't prevent the vehicle from moving. In this case make sure to apply parking brake completely and put obstacles at both sides of the rear tire in diagonal direction with the front flat tire.

Note

After replacing the tire, check its inflation pressure and if it is necessary adjust the tire pressure at the specified amount.



Chapter 6

Guideline for using bi-fuel powered vehicle*

CNG introduction	115
Engine compartment	117
Instrument panel	118
Fuel convert switch	120
CNG fuel tank indicator	122
Fuel charge	123
Safety factors and necessities	125
Vehicle control and maintenance	130
System repair	131
System primary troubleshooting	132
Periodic service operation	133



* According to car model.

Preface

Preface

Thank you for purchasing pride vehicle equipped with CNG system. Your choice is not only optimum use of country's energy resources but also protects environment resources, supports the reduction of pollution and fuel consumption significantly.

Please review owner manual prior driving the vehicle. This manual includes the adequate and beneficial information regarding the method of driving the vehicle and also acquaints you with the vehicle equipment. The owner manual also includes vehicle CNG system maintenance, services and safety factors.

Note:

Refer to nearest authorized dealership for maintenance and services. The vehicle should not be repaired by unauthorized and unskilled person.

Note:

You should not use and install parts and equipment which are not confirmed by authorized agents and also you should not service the vehicle in unauthorized agents, because the followings not only contravene the validity and terms of the vehicle guaranty, but also reduce the passengers' safety.

Familiarity with CNG and Advantages and Disadvantages of It:

The natural gas which is mainly composed by methane (CH₄) is a substitute for gasoline (petrol) or diesel fuel used in vehicles. It is considered to be an environmentally clean fossil fuel alternative to those fuels. The natural gas does not contain cancerous particles of carbon black (soot), lead and aromatic hydrocarbons such as benzene. The benzene is reduced by 99% in NGV (Natural Gas Vehicle) compared to petrol-powered vehicle and the pollutants' range of petrol-powered vehicle exhaust's emissions are more than NGV.

The research of NGVs' (Natural gas vehicles) effects on global warming (as the global warming is depending on the vehicle condition) indicated that NGVs reduce 17% global warming in complete fuel cycle.

The NGVs are practically compatible and congruous with urban environment because the emissions through exhaust pipes are within the determined and allowable range of the vehicles' pollutants. Due to NG being the most environmentally-friendly fuel and proved nature of reducing pollution particularities many countries apply subsidy to NGVs.

NGV consume the same gas as used in the offices and houses for heating systems, kitchen and so on. NG supplies as compressed or liquid form for vehicles. NGVs are cleaner, safer and less noisy (the NG heavy duty engine vehicle noise level is the same as a light duty diesel engine vehicle). Compressed natural gas (CNG) is less dangerous than liquid fuels such as petrol, gasoline and liquid gas because it is thinner than air and in case of a leak it is dispersed into the atmosphere with no harm to the environment. Also, CNG is less inflammable. Natural gas transfers by pipe line, so no fuel tanker danger involved and also no LPG transport limitation is required.

The catalytic converters used in the vehicle exhaust system are causing the reduction of pollutants in vehicle exhaust's emissions such as carbon monoxide, hydrocarbons and nitrogen oxide. The NGV emit less carbon dioxide than petrol-powered vehicles. NGVs have pollution advantages.

CNG Introduction

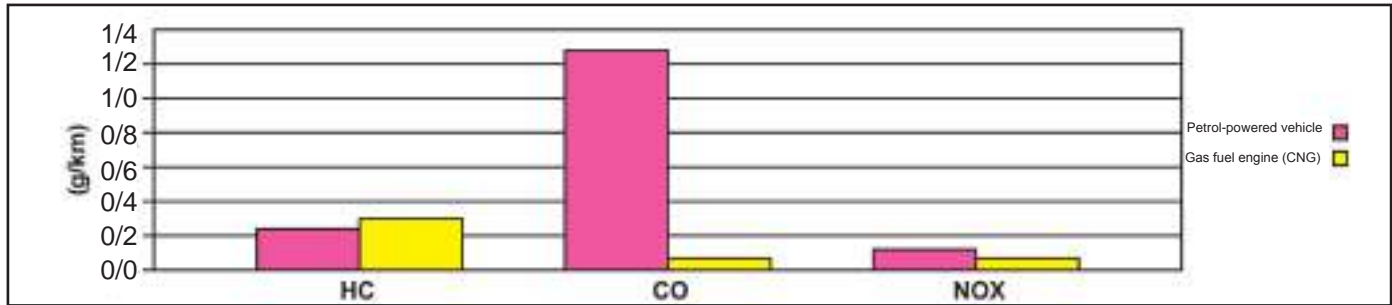

CNG introduction

Research and test results on two similar vehicles' exhaust emission under different driving conditions in the world, one petrol-powered vehicle and other one NG vehicle indicates that the pollutants emission from the NGV is less as illustrated in the graph above without replacing the exhaust catalytic converters.

6

Using NG will result in no pollutants such as soot, and suspended particles in the air which causes lung troubles and allergy such as asthma.

One of the particular advantages of NGV compared to petrol or diesel-powered vehicles is producing less noise. Another advantage is less explosion probability in vehicle accidents because NG is thinner than air and in case of a leak it is dispersed into the atmosphere with no harm to the environment. Normally NG pressurized canisters with 200 bar are installed in the vehicles. The different volume and required number of canisters (tanks) depend upon the vehicle engine weight, size and volume. A petrol tank in addition to the NG canister is installed on the bi-fuel-powered vehicles, so the NGV travels more than petrol-powered vehicles.

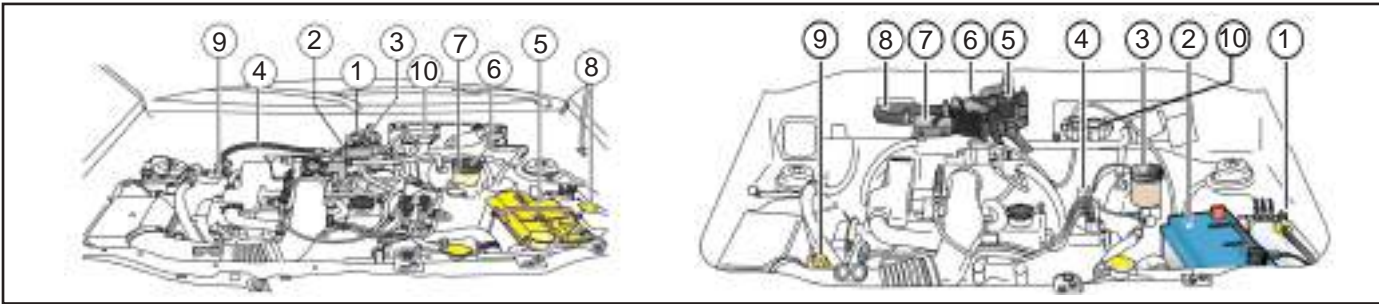

Improved Engine Compartment Part (Equipped with CNG)

- 1- Radiator fluid overflow tank
- 2- Battery
- 3- Brake fluid tank
- 4- Coil
- 5- Gas stop solenoid valve
- 6- Regulator
- 7- Gas fuel distributor
- 8- Gas fuel low pressure pipe
- 9- Oil gauge
- 10- Inertia switch

Bosch Engine Compartment Part (Equipped with CNG)

- 1- Gas regulator (high pressure)
- 2- Gas stop solenoid valve
- 3- Gas pressure sensor
- 4- Gas hose (low pressure)
- 5- Battery
- 6- Brake fluid tank
- 7- Coil
- 8- Radiator fluid overflow tank
- 9- Gas fuel distributor
- 10- Inertia switch

Instrument Panel



Front display

- 1- Speedometer
- 2- Engine thermometer
- 3- Digital odometer and trip odometer and CNG fuel level
- 4- Water overheat alarm light
- 5- Trip odometer resetting button
- 6- Engine tachometer
- 7- Fuel gage indicator
- 8- Fuel gage warning light
- 9- Fuel gage pointer

6

Whenever this indicator **CNG** is on, the vehicle is in gas combustion situation and when it is off the vehicle is in petrol combustion state.



Front display

- 1- Speedometer
- 2- Engine thermometer
- 3- Digital odometer and trip odometer and CNG fuel level
- 4- Water overheat alarm light
- 5- Trip odometer resetting button
- 6- Engine tachometer
- 7- Fuel gage indicator
- 8- Fuel gage warning light
- 9- Fuel gage pointer

Whenever this indicator **CNG** is on, the vehicle is in gas combustion situation and when it is off the vehicle is in petrol combustion state.

Fuel Status Changing Key



Fuel Status Changing Key

In injector gas combustion vehicle the fuel status changing key is in “Push button” format. By each time of pressing it upwardly and a proper pausing you can change the automotive fuel position. This key is placed on the dashboard.

Automotive Performance Using Gas and Petrol

Due to the fact that performance with the gas fuel is preferable, the system performance manner has embedded in a way that the automotive is always start up in petrol-based status and then in case of achievement of the required conditions (e.g. temperature...) it may automatically be changed such status to gas-based.

The status of the consuming fuel type at anytime is informed to the driver using the fuel status indicator embedded on the instrument panel. Also the driver may change the fuel status

from gas to petrol and vice versa by pressing the fuel status switch. However changing the fuel status is applicable when the engine heat reaches to proper temperature and the fuel in petrol/gas tank is of enough content. If the automotive is working under gas-based status and the gas is finished, then the engine management system changes the status to petrol-based automatically. If automotive is working under petrol-based status and the petrol is low then such system changes the status to gas-based automatically, in this case there is still some fuel remained in fuel tank.

Engine control unit (ECU) keeps such amount of fuel for the next start-ups, so that in next start-ups enough petrol could be furnished. It should be mentioned that changing the fuel status is performed when there is enough fuel in gas/petrol tank.

An important point regarding the type of fuel

The respectable owners of this automotive shall be aware that it is necessary to use petrol and gas alternatively. If the automotive works either with gas or petrol for a long time, then it may get trouble with the injectors and other components. So it is necessary not to drive the car using a single fuel type for more than 1000Km, and after traversing 1000Km by one type of fuel, the other fuel shall be used at least one full tank.

CNG Tank Content Indicator



CNG Tank Content Indicator

The fuel tank level digital indicator is observable in instrument panel beside where the odometer is placed. This indicator is shown in the form of cylindrical charts and with five levels of 3/4, 1/2, 1/4, empty and full. In case of running out of gas the CNG fuel content indicator starts blinking. (The numeral which is seen underneath is related with the distance taken by the automotive.)

Due to the fact that at some of the CNG feeding stations and sometimes because of technical reasons, the feeding gas pressure differs from the

standard pressure, so the content of the gas pressure and volume might not be fixed and it might turn off sooner than the expecting desired time. In this case there is no problem in the display system or over consumption of gas, and they are working normally.

Consuming fuel type indicator

Fuel status indicator is shown in the symbol of the tank and the CNG expression on the front display. While the automotive is using gas the indicator light is on, and when the automotive is using petrol the indicator light is off.

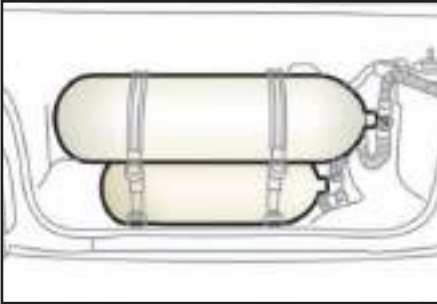

CNG Cylinder Safety Points

The CNG tanks are designed with high safety factors, and in order to make sure the proper operation of the tanks and their high pressure pipes and fittings, periodic controls must be applied to them. So it is important for the owner to pay attentions to follow-ing points:

- The Cylinder must not be scratched by any objects placed in the vehicle trunk.
- The Cylinder safeguard must be controlled every six month to check if there is any looseness due to the shakings.

- To access the tanks valves you need to open the trunk lid and remove the trunk carpet.
- The Cylinders must be periodically controlled by authorized stations every three years.
- As the eventually leakage is lead to the outside by the conditioner channel, in order to prevent gathering gas inside the vehicle, make sure the rectitude of the followings: The well condition and correct conjunction of the hoses and gas filler valve washer, tightening of the bracket hoses located in the trunk.

Fuel charge

The fuel charge procedure is as follows:

- Turn off the engine.
- Open the filler valve knob.
- The station operator will put the special fuel charging equipment on the proper place and it will fill the tank.
- After fuel charging, close the valve knob in its seat, tightly.

Correct Assembling of the Hoses and Brackets

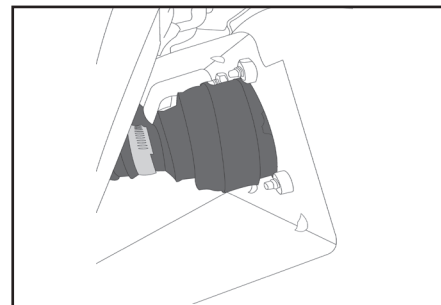
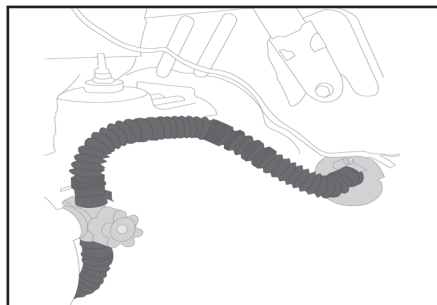
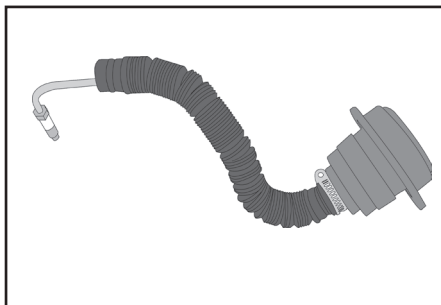

The correct way of assembling the hoses filler seal washer and brackets is shown on the figure.

Safety Points and Necessities in Bi-fuel-powered Vehicle

The general cares which the drivers must perform during fuel charge are:

a) General safety factors for bi-fuel-powered vehicle users

- If you smelt gas particularly early in the morning and before starting the engine, fasten the safety valves fitted on both tanks and use petrol to drive the vehicle to the nearest authorized agent.
- If gas smell is sensed clearly, tow or push the vehicle out of the confined space to open area. In this condition, no consumption sources must be activated, no electric switches must be turned off or on and the engine must not be ignited.

Note: *If there were any gas smell, the vehicle door must be opened with extensive cares because the doors switches and related lights or battery disconnection may result in sparks.*

- It is recommended to use anti freeze in all seasons, otherwise the CNG system and the engine parts and components may damage.

b) Safety factors during fuel charge

- The engine must be turned off before charging.
- The driver should come out of the vehicle and allow the operator to charge the gas.
- The driver should make sure that the filler valve is closed.

2- Kit safety points:

- Due to the high pressure gas in the bi-fuel-powered vehicle and system components sensibility to any defect, the owner must be familiar with the kit components safety points and review the safety points stated in the manual and refers to the nearest authorized agent for troubleshooting in case of any problem.

Safety Points and Necessities

The followings are some of the problems which can be identified by the driver:

a) Safety points about high pressure gas pipes, filler caps and fittings

The driver must review the information quoted on the label near filler. The information is:

- Gas type which is CNG
- Tank expiry date
- System service pressure

In case of damages in fuel pipes, consult to authorized agent for replacement. (Repairing the damaged fuel pipe is forbidden)

Refer to the nearest authorized agent if either of the followings are observed on high pressure pipes and fittings:

- In case of any corrosion, erosion, wears and damages due to impact on the tank fitting and other high pressure fittings.
- In case of tank bolts atrophy due to tension, cracks on tank body, room or tank's frame metals erosion and...
- In case of erosion, twisting and damaging of gas pipe cover and flexible hoses.

The aforesaid points are controlled once a year by authorized agents.

6

To prevent dust or liquid or other external particles penetration into the tank, the filler valve cap must be fastened on its place after fuel charging. Regarding to the above points, the following about the gas discharging security instrument, must be controlled periodically:

Any operation which generates heats such as welding that are performed near the high pressure pipe and fittings must not increase the high pressure pipes and fittings temperature higher than the surrounding temperature; otherwise the insulation cover must be used.

Refer to the nearest authorized agent in case of observing any cracks or holes on the plastic pipes. If the vehicle is not going to use CNG for long time under any reason, the CNG system main shut off valve must be turned off. To prevent gas accumulation as the result of gas pipe damages such as rupture or bend, the gas flow of each tank must be completely stopped by shutting off individual tank valve.

b) Safety Necessities About Discharging Gas Pressure Instrument

The high pressure gas system is equipped with the following safety mechanism to prevent pressure increase more than standard pressure of 260 bars:

- Safety discharging device fitted inside the tank for prevention of pressure increase in excess of standard comprises of the following mechanism:
 - Pressure sensitive plate
 - Temperature sensitive part
 - Gas flow control, which is a device for shutting off the CNG flow if the pressure increases due to CNG leak to atmosphere as the result of high pressure pipes damages.

C) Safety points about pressure reducer (Regulator)

- It is necessary to control the regulator movement or looseness monthly.
- In case of severe pressure drop the temperature at regulator boundary will drop severely too. Refer to the nearest authorized agent, if regulator body freezes after starting the engine on which it is due to insufficient circulation or cut off the regulator heating fluid.
- Since the regulators warm up by the radiator water flows around the head cylinder, you should use standard anti freezing which won't have negative effects on the regulator function.
- The regulator should not be supported by the gas pipes connected to it. Refer to the nearest authorized agent in case of any deformity in the gas pipe connected to the regulator or if gas pipes and its supporting clamps are freed from each others.

Safety Points and Necessities

- In case of any looseness in the solenoid valve connection or other fittings of gas pipes and hoses, refer to the nearest authorized agent.

d) Other Important Safety Points

- The washing liquid must not be poured on the electric connections and CNG system equipment when washing the engine.
- Gas tanks and their supporting straps must be controlled for any damages. Refer to the authorized agent in case of any damages to the tank assembly.
- Gas tank must be controlled individually, and they must be controlled for proper installation.
- The leak test of pipes and hoses must be done with soap and water in order to find any defect in pipes and hoses such as wear, tear, deterioration and erosions.
- In severe car crash or accidents the gas tank may get separated from its holding straps or its gas pipe. In this case take the vehicle to the authorized agent for controlling the tank.
- The tank must be strapped firmly on its place, and there should be no looseness or loosen nuts and bolts.
- Thee straps must be bolted to the body firmly and in proper place.

6

Safety Points and Necessities

- The fuel pipes and drain pipes must be firmly connected and fitted on the vehicle.
- The rubber washer under the straps must not be twist or deformed and they should be fitted properly on their places.
- consult to the authorized agent if the valve or safety connecting pipes or pressure discharging device or tank is damaged.
- If you sniffed gas smell around the tank or gas pipe, refer to the authorized agent for checking.
- The tank surface must be completely smooth and there should be no dip on it.
- Files must not be used to remove rust on tank surface.
- Never pour acidic liquid on the tank surface because they damage the paint and consequently the metallic tank will erode and the composite tank resin will be damaged.
- Although there is a carpet in the trunk, be careful when carrying acidic materials not to damage the tanks.

Vehicle Maintenance and Inspection

Vehicle Maintenance and Inspection

Observe the followings while using the gas- consumption vehicle:

By observing these simple points, in addition to preventing dangerous events, you will increase the vehicle life time:

The points to be inspected are:

- 1- Gas leakage from tank and joints
- 2- Perforation or cracks on the plastic pipe surface
- 3- Tightness of the electrical components connectors such as shut off valve and etc.
- 4- Fuses intactness
- 5- Tightness of the regulator connection point, refuel valve, electrical valve and high pressure pipes.

CNG system repairs

Pay attention to the following points, for periodic control and while driving the bi-fuel-powered vehicle:

- Valve adjustment
- Inspection of plugs and sparking cable
- Idle speed controlling (operation control inspection) and respective parts
- Engine operation control while using petrol with particular attention to Lambda sensor
- Reading errors code
- Controlling hoses clamps
- Controlling electric connections
- Controlling negative electric connection
- Controlling part's clamps
- Controlling gas tank leakage
- Controlling air suction
- Controlling pressure reducer operation



The above points should be performed by authorized agent of SAIPA YADAK Company not by the owner.

Primary System Troubleshooting

Troubleshooting

Inspect the followings if the automobile does not work under CNG status:

- Whether there is enough gas in the CNG tank?
- Whether there is enough petrol for starting up in petrol status?
- Whether the fuses are intact?
- Avoid applying fuses except for items recommended, because this will result in conking out of ECU.
- In case of any failure in the gas combustion system while driving, inspect whether such failure occurs in petrol combustion status.
- If all above points was controlled and there were still any defect, consult just with the authorized agent and do not repair the defect yourself or unauthorized agents because this will result to invalidity of the guarantee.

Periodic Service

period				Operation	Travel [km]			
Three years	Two Years	One Year	Six month		100000 [Km]	50000 [Km]	30000 [Km]	15000 [km]
			*	system leak test				
		*		Gas filler valve washer inspection		*		
			*	Gas tank guard inspection		*		
*				Gas tank inspection		*		

Note

The gas tank life time is 15 years and after this time they should be replaced.

Note

It is necessary to use tires with 40 psi (equal to 275kpa) maximum tolerable pressure for bi-fuel-powered vehicle.



CHAPTER 7

Vehicle maintenance and guarantee

- Brake system maintenance	136
- Clutch adjustments	138
- Power steering maintenance	139
- Owner services	144
- Engine compartment	145
- Engine oil and oil filter	146
- Engine cooling system	148
- Checking windshield washer fluid level	152
- Replacing wipers blades	153
- Battery maintenance	154
- Tires maintenance	156
- Replacing lamps	162
- Changing oils	166
- Vehicle body maintenance	167
- Vehicle internal trimming maintenance	170



Braking System Maintenance



Braking System Maintenance

Inspecting brake booster operation:

Test the performance of brake booster according to the following:

1-push the brake pedal several times and then keep it down and start the engine. After igniting the engine, the brake pedal comes up slowly.

2-push the brake pedal and stop the engine. Keep the pedal down for 30 seconds in this time, pedal doesn't move.

3-start the engine again and let it works for 2 minutes. Now push the brake pedal more times. Pedal's movement should reduce after each pushing. Otherwise there is malfunction in brake system and you should refer to authorized agent of SAIPA YADAK Company.

Brake fluid inspection

Check the brake fluid level, the fluid level inside the tank should be between MIN and MAX. Add fluid up to MAX level, if the level is just under or above the MIN, or if the fluid warning lamp is turned on.

Clean the tank cap in order to avoid entering unused materials, before adding fluid.

Note that the brake fluid level may decrease after travelling long distance. Refer to the authorized agent if the level in the tank was too low or if the tank needed to be charged in short time periods.



Environment and vehicle

Brake fluid is a synthesis compound, which most part of it is the enteric poly glycol compounds. Therefore, never pour it on the soil and through the water.

Caution

Use merely standard brake fluid. Do not mix different branch of brake fluid together.

Warning

Brake fluid is poisonous and it should be kept in a capped container and out of reach of children. Call to the doctor if the brake fluid was swallowed.

Note

Be careful not to drip the brake fluid onto the hot engine since it is flammable.

Note

Brake fluid damages paints, so if spilled on the vehicle wipe up with a clean fabric and wash the part with water and vehicle shampoo.



Brake pedal clearance inspection

To measure the brake pedal clearance, turn off the engine and push the brake pedals few times with your foot. Then push down the brake pedal with your hand until you feel a slight reaction. Call to the authorized agent if the pedal clearance is less than 4mm or more than 7mm.

Brake pedal maximum travel

Start the engine and inspect the brake pedal travel as follows:
Press down the brake pedal as far as it travels. The distance between the pressed pedals and the bear floor



(without mat and carpet), should be 61mm minimum, otherwise refer to the authorized agent.

Parking brake inspection

Note that the parking brake should hold the vehicle on the very steep road.

Pull up the parking brake slowly and count the clicking. The number should be between 5 to 7 otherwise refer to the authorized agent.



Clutch Adjustment



Clutch pedal clearance check

Push down the clutch pedal with your hand until you feel a reaction. The clutch pedal clearance should be between 9-15mm. If the clearance is more or less than the above, refer to the authorized agent to adjust the clearance.



Clutch pedal height check

Measure the distance between top surface of the clutch pedal and the floor as shown in the figure. It should not be more than 213mm and less than 208 mm otherwise, refer to the authorized agent.



Environment and vehicle

Brake lining/ clutch facing

Though the SAIPA products obey the forbidden law of using the materials, which have asbestos, and by using the brake linings/clutch facings that have the replaced fibers unfortunately non-authorized brake linings/clutch facing are available in nongovernmental markets. Therefore, it is better to buy brake linings/clutch facings from an authorized dealer or pay attention to the “free Asbestos” phrase on these parts.

Necessary information: necessary information label is placed under the engine hood.

(Hydraulic Power Steering)

Appropriate lubricant oil used in hydraulic power steering

1- DEXRON II

2- PSF – III

Required volume: 875cc

Note:

The oil level should be checked by the gauge bar fitted on the oil reservoir cap at engine is OFF. The oil level should be between L and H mark on the gauge bar.

Refer to vehicle manual for oil change or control.

The hydraulic power steering is not function with engine OFF.

Never hold the steering wheel to either complete left or right more than 5 second when the vehicle is parked with the engine is ON.

Refer to Saipa Company authorized dealership if the system is malfunctioning.

Power Steering Maintenance

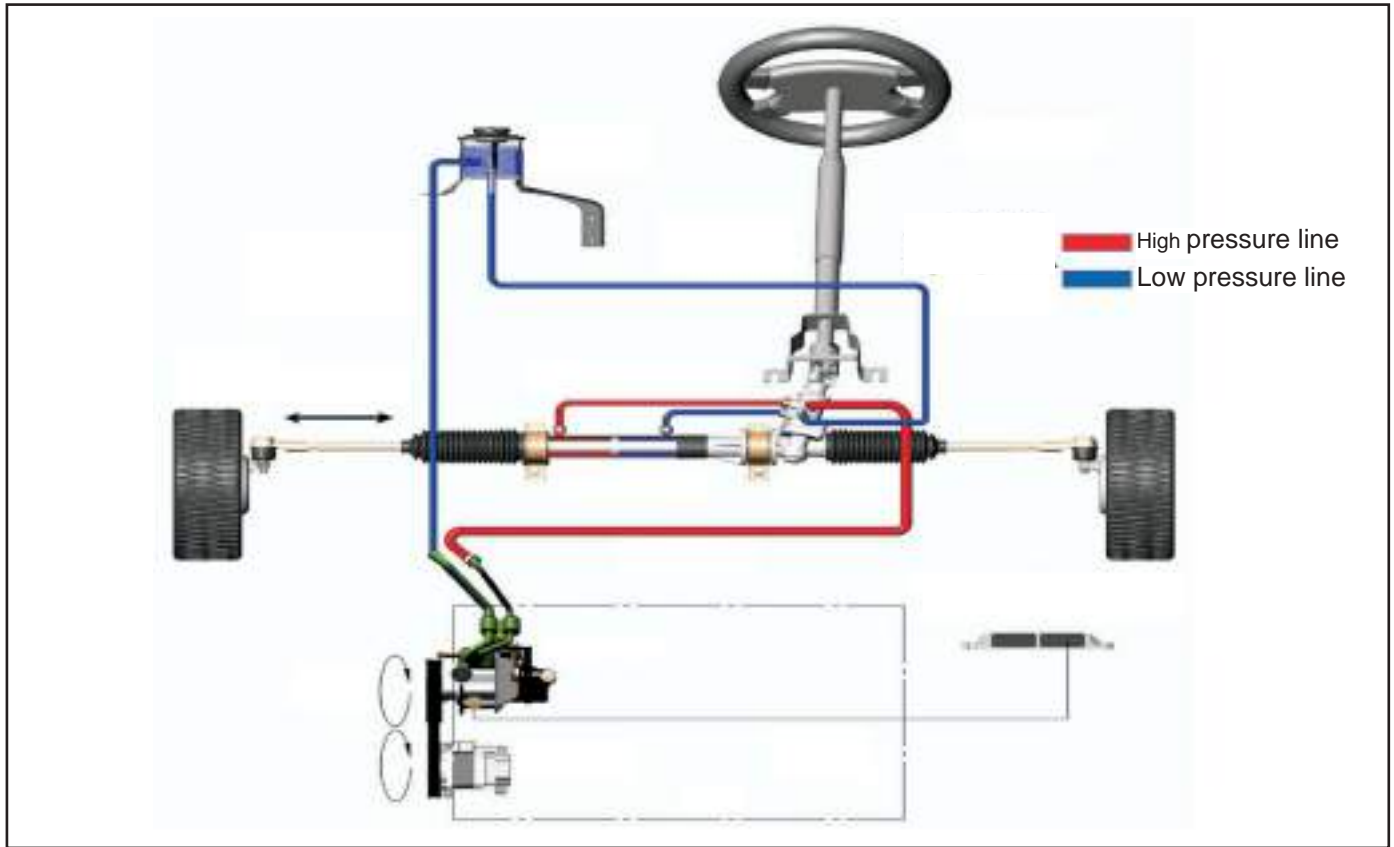

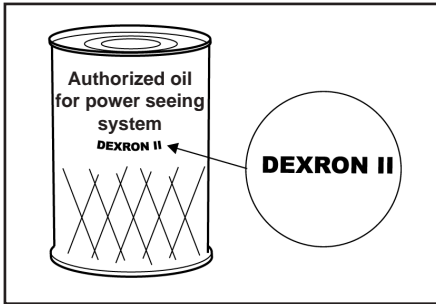

Authorized oil

The followings are authorized oil for power seeing system:

- 1- DEXPRON-II
- 2-PSF-III

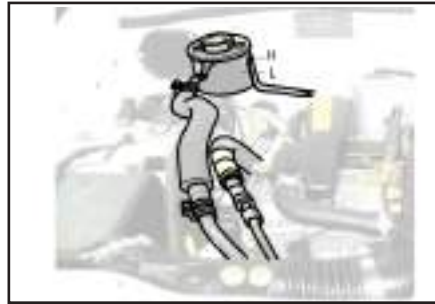

Oil level

The required oil volume is 875cc.

Note

- 1- The oil level should be checked by the gauge bar fitted on the oil reservoir cap at engine off. The level should be between L and H mark on the gauge.
- 2- The power steering does not operate while the engine is off.
- 3- In case of malfunctioning the power steering, the normal steering works but you should apply extra force.
- 4- Never hold the steering wheel to

either complete right or left more than five seconds while the accident happened and the vehicle is parked with engine in on situation.
5- Refer to the authorized SAIPA YADAK Company in case of any problem in power steering operation.

Note

The power steering oil should not contain any dust or external particle, since they may harm the power steering system severely.

Power Steering Maintenance

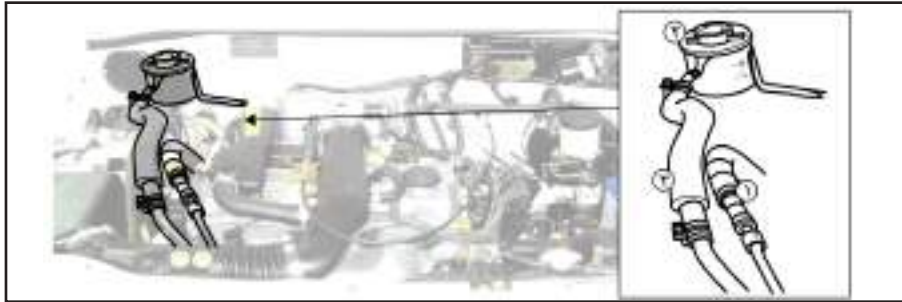

Component case

- 1- High pressure fluid pipe
- 2- Tank
- 3- Suction pipe

Belt situation

- 1- Crankshaft pulley
- 2- Air conditioner compressor
- 3- Belt*
- 4- Hydraulic pump



* Belt specification: 4PK930

Checking power steering fluid level

The power steering fluid level must be checked periodically. To do so, turn off the engine and stop the vehicle on a flat surface.

Check the power steering fluid reservoir level. This must be between L and H indicator level installed on the fluid reservoir cap.

Before adding the power steering fluid, clean completely the power fluid reservoir cap and the area around it to protect from its contamination.

If the power steering fluid level is low, add the fluid in to the reservoir until the H level. If you need to add hydraulic oil continuously, consult an authorized SAIPA YADAK company agent for inspection of the vehicle.



Note

To protect the hydraulic pump from damage, do not drive for a long period of time the vehicle whose power steering fluid level is low.

Only use the specified power fluid (refer to the section of power steering fluids in the current chapter).

Penetration of any dust and particles in to the power steering fluid reservoir cause serious damage in the power steering system.



Environment and vehicle

Grease, lubricants

Grease and lubricants are consisted of elements such as sodium, calcium, aluminum, barium and copper. In order to increase the ability of grease in reducing the wear, the compound of disulphide molybdenum is added to it. Therefore, be careful about the leakage.

Vehicle's owner responsibility

Vehicle's owner responsibility

The following items are a collection of inspections and investigations which must be carried out by the vehicle's owner or an expert mechanic at the mentioned time intervals (related to vehicle's type) to have a safe and comfortable driving. If you have any trouble, consult immediately an authorized SAIPA YADAK agent or an expert mechanic to get help. The maintenance costs are not covered by the vehicle guaranty. The costs of services, parts, and oil will be charged to the vehicle's owner.



Warning

When driving the vehicle notice the followings

- Notice to any change in exhaust noise or smell in exhaust gases.
- check any vibration of steering wheel.
- Reduction or increase in required power to turn steering wheel (Be careful to the direction change of steering wheel from straight ahead.).
- When stopping the vehicle notice if there is any abnormal noise, dragging the vehicle to one side, increasing the pedal movement or pedal tightness.
- If there is any change in the transmission performance, check the transmission oil level.
- Check the parking brake function.
- Check any leakage from the vehicle.

(Notice that the dripping water drops from A/C system is normal after using it).

Vehicle's owner responsibility

*At least per month check the following items:

- The engine coolant level inside its tank.
- The proper function of vehicle's exterior lamps such as brake, signal, and flasher lamps
- The power steering fluid level.
- The engine oil level.
- The brake fluid level.

***At least two times every year (such as spring and fall) check the following items:**

- The function of windshield wiper blades (clean the wiper blades by a piece of cloth soaked in the washer fluid.).
- The proper function and proper place of safety belts.
- Tire wheel situations

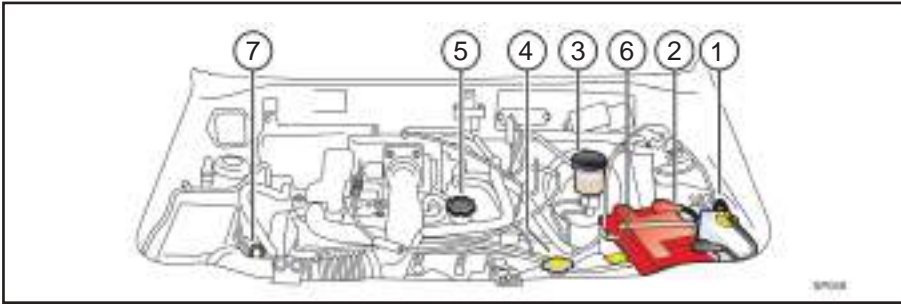

Engine compartment guide (equipped with injector system)

- 1- Engine coolant reservoir
- 2- Battery
- 3- Brake oil tank
- 4- Radiator cap
- 5- Engine oil fill cap
- 6- Windshield tank-washer
- 7- Engine oil level dipstick

Engine Oil and Filter

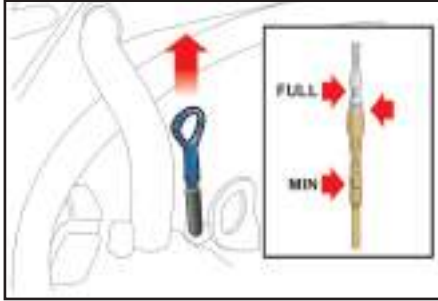

Engine oil level check

- 1- Stop the vehicle on a flat surface.
- 2- Start the engine until its temperature reaches at normal working temperature.
- 3- Turn off the engine and wait until the oil drains back in to the oil pan.
- 4- Pull out the dipstick and clean it, then push it back in all the way.
- 5- Pull out the dipstick again checks the oil level. The oil level must be between marks F and L. If the oil level is at L or close to it add enough engine oil until its level stays at F. Notice that do not add too much oil.

Only use the right kind of engine oil (refer to the section of recommended oils in this chapter).

Warning

- Long term used engine oil contact with the skin can cause cancer. Therefore, after touching the used engine oil wash your hands up with soap and water.
- Keep away the engine oil from the children access.

Environment and vehicle

Engine oil

- Prevent environment pollution by furthered replacement of the engine oil.
- The engine oil color is not the only criteria for defining its quality and replacement.
- The base of many engine oils is the crude oil. So conserve the resources by optimized consumption.
- Be careful about the leakage when replacing the engine oil. Avoid pouring the used oil on the soil and through the water.

Changing Engine oil and filter

The time intervals of the engine oil change and the air filter should be according to the scheduled maintenance of the vehicle explained in the current chapter.

- 1- Start the engine for several minutes and then turn it off open the engine oil fill cap.
- 2- Remove the oil fill cap and open the drain screw, drain the oil in to suitable pot.
- 3- Open the oil filter using the special tool.
- 4- Clean the assembling location of oil filter with a piece of fabric.
- 5- Soak the new O-ring in the engine oil.
- 6- Tighten the drain screw after completely draining the oil.
- 7- Install the oil filter using the special tool.
- 8- Fill the new oil into the engine until its level reaches at 'F'. Be careful do not add oil more than specified limit.
- 9- Tighten carefully the oil fill cap.

10- Start the engine and check if there is any oil leakage around the O-ring of oil filter.

11- Check the oil level and if it is required fill the oil until it reaches at F level.

Caution

Both the engine and its oil are hot, be cautioned do not injure yourself.

Note

Be careful the O-ring of old oil filter to be removed. Otherwise it may cause the oil leakage and engine damage.

Pay attention that consumable oil should be the definite quality grade.

Note

- Although the oil filters may be identical in appearance, their internal design can be different. These kinds of filters cannot be used instead.

To protect engine from damage, use only the specified filter (consult an authorized SAIPA YADAK agent).

-Follow carefully the instructions. If you do not install the oil filter properly, the oil will leakage and this will damage the engine.

Engine Cooling System

Engine Cooling System

The engine cooling system is pressurized and it has a reservoir containing all season anti-freeze coolant. Check the cooling system coolant level, before winter time and traveling cold weather areas.



Warning

Removing Radiator Cap

- Do not remove the radiator cap when the engine is on at all. This can damage the cooling system and the engine itself. Also, emitting of water vapor can cause serious injuries.

To remove the radiator cap:

- First turn off the engine and wait until it cools down. When removing the radiator cap be precautious.
- Use a thick towel to remove the radiator cap by gently turning it counter-clockwise to open the first step.
- Wait until the internal pressure of the radiator reduces and no emission of coolant occurs.

Push down the radiator cap using the thick towel and turn it all the way counter-clock wise to remove.

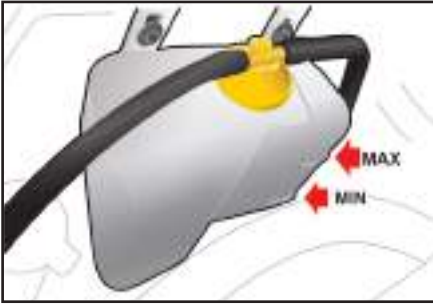

Checking engine coolant level

Check all the fittings and hoses of cooling system and replace the defected and deformed hoses.

The coolant level when the engine is cold must be full in the radiator and between MAX and MIN marks inside the coolant reservoir.

If the coolant level is low, add enough coolant until its level reaches at MAX level.

Be careful do not add more coolant than the specified MAX level.

If the coolant level reduces continuously, consult an authorized SAIPA YADAK agent for inspection of the cooling system circuit.

Changing engine coolant

Follow the scheduled maintenance period of the vehicle regarding changing the engine coolant.

- Use unsalted water to mix up with the coolant.

- Since there are aluminum parts used in your vehicle, to protect them from erosion use coolant with ethylene glycol base.

Engine Cooling System

- never use alcohol and methanol in the coolant at all and do not mix up them with the coolant.
- Do not use a solution with more than 60% or lower than 35% of anti-freeze. Otherwise, the coolant will not function properly.
- To see the anti-freeze effect on the coolant properly refers to the table.

Boiling point °C	Freezing point °C	Anti-freeze volume percentage in the water
101	-4	10
102	-7	17
103	-10 ~ -11	25
105	-17 ~ -18	33
108	-36 ~ -37	50
111	-50 ~ -52	60

Note

The values listed in the table are related to the anti-freezes which have glycol base. Using anti-freezes are recommended both for winter and summer times. The mixture of 50 percent water and 50 percent anti-freeze as the engine coolant also recommended.



1- Remove the radiator cap (as it explained before) by turning it counter-clockwise.

2- Loosen the drain screw of the radiator to evacuate the coolant in to a suitable pot.

3- While the drain screw is open let water flow in to the coolant system.

4- After completely evacuating the coolant system, tighten the drain screw.

Add the required amount of water and ethylene glycol mixture to protect the system from erosion and icing.

In the cold weather terrain use the specified amount of anti-freeze with

ethylene glycol base according to the manufacturer's instructions.

5- While the radiator cap is open start the engine and let it run in the idle condition. If it is required, add the coolant gently.

6- Now, wait the engine to reach its normal temperature.

Press the accelerator two or three times and add the coolant as required. Be careful not to be burned.

7- Tighten the radiator cap and inspect all the fittings if there is any leakage.

8- Check the coolant level inside the coolant reservoir again.

After several days driving check the coolant system and add coolant if required.

Checking Windshield Washer Fluid Level

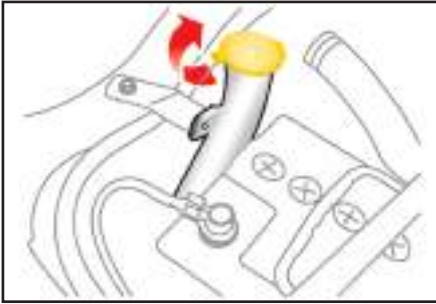

Check the windshield washer fluid level inside its reservoir and add the fluid if required.

If you do not have washer fluid use clean water. If the weather is cold and there is a possibility of freezing use a solution with anti-freeze property as washer fluid.

Caution

Do not use coolant inside the radiator as washer fluid, in the washer fluid reservoir.

If the coolant inside the radiator is sprayed on the windshield, it will severely reduce the driver vision and cause lack of vehicle control, resulting in an accident. Also coolant can damage the body and trim of the vehicle.

Replacing Windshield Wiper Blades

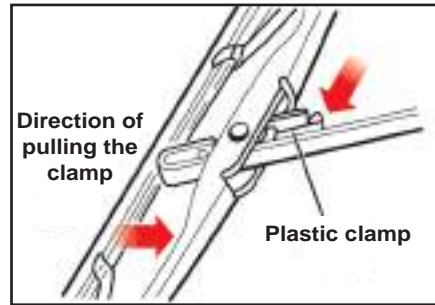

Replacing windshield wiper blades

When the windshield wipers do not clean the windshield properly, first clean windshield then clean and wash wiper blades with water and cleaning materials and check wiper blades function again. If windshield wipers do not clean the windshield properly the wiper blades may have crack or torn. In this case, replace the wiper blades.

Pull the windshield wipers arms from the windshield and turn it so that its plastic clamp is visible. Press the clamp and slid the blade toward the windshield, then pull it out from the wiper arm.

Be careful about the wipers arms must not fell on the windshield.

Note

To prevent from damaging the wipers arms and the other parts of the wipers, do not move them manually.

Wiper arm maintenance

Note

If the windshield is not cleaned by wipers properly, clean the windshield and wiper blades with a suitable detergent and wash it with water.

To protect the wiper blades from damage, do not allow gas oil, kerosene, thinner, and other solutions to touch them.

Battery Maintenance

Battery

Before working on the battery, notice to the following instructions.

- Keep away any cigarette, fire, and spark from the battery.
- Hydrogen gas is strictly flammable. This gas is generated in each cell of the battery continuously and it will explode in case of fire.
- If your eyes touch with the electrolyte, wash them at least for fifteen minutes with water and consult a doctor for treatment. If it is possible use a wet towel or sponge to clean your eyes before getting medical aids.
- If your skin touches the electrolyte of the battery, wash it totally with water. If you feel any pain or burning, consult immediately for medical treatment.
- Keep away the battery out of reach children due to sulfuric acid inside it.
- Be careful the acid of the battery does not touch your skin, eyes, clothes, or any painted part.
- Use safety goggles when charging or working near the battery.

- If you are working in a place where the battery is stored, make sure its ventilation system is active.
- When carrying a battery with plastic body, be cautious not to apply pressure on its body. This may cause acid leakage which may injure you skin.
- When the battery cables are connected do not charge the battery.



Environment and vehicle

Battery

One of the most important pollution of vehicle battery is lead and sulfuric acid. Therefore, you should not leave the used and old batteries in the environment. You should give them to the authorized stations.



Battery maintenance

- Fix the battery firmly and safely in its place.
- Keep the battery completely dry and clean.
- Be careful the terminals and connections of the battery to be clean firm.
- If there is electrolyte on the battery terminals, wash it immediately with water.
- If you do not want to use the vehicle for a long time, disconnect the positive and negative cables of the battery.
- Check the electrolyte level of the battery initially installed on your ve-

hicle.

-It is recommended that in summer time and when using A/C, check the water level of the battery and add distilled water if required.

Note

Consult an authorized SAIPA YA-DAK company agent, if the battery becomes discharged or appearing any abnormal indications

Taking Care of Tires and Wheels

Taking care of tires

To use the vehicle properly and safely and also to increase fuel economy, always adjust the tires pressure and follow the loading limit.

Tire pressure

It is necessary to check the pressure of all the tires including the spare tire every month. Measure the tires pressure when they are cold. (This means that the vehicle is not driven last three hours or the driving distance is lower than 1.5 kilometers.).



Notice that the recommended tire pressure must be followed to drive safely and to have minimum wearing of the tires.

All the information regarding the tire size and pressure is written on a tag attached on the lower part of front door sealing edge as shown in the figure.

Tires and wheels

Pay attention to the followings about the tire pressure:

- The warm tire pressure is more than the cold one. Therefore, do not use warm tire adjust its pressure. Otherwise, after cooling the pressure will be lower than the specified limit.
- If the tire pressure becomes lower than the specified limit, the wear rate of the tire and the fuel consumption will increase and the control of the vehicle will be difficult. Also, low pressure tire can explode and its sealing with ring will not be enough. If the tire pressure becomes much lower than the minimum specified value, it will cause deformation of wheel or separation of tire. Therefore, keep the tire pressure in the specified limit. If the tire pressure continuously reduces, consult an authorized SAIPA YADAK agent or a puncture workshop.
- The tire pressures more than the specified limit causes knocking when driving, difficulty in vehicle control,

wear in the tire middle part, and more likely of overturn.



Warning

The tire pressure more or less than the recommended limit reduces the tire life time and causes bad handling of the vehicle in driving. Also, it can cause tire cut or blow up resulting in loose of the vehicle control.



Environment and vehicle

Tire

If only one of the vehicle tires has pressure drop, say 6 psi (0.4 bar approximately), and the others have standard pressure, the fuel consumption increases to 3% and the life of that tire would decrease.

You can reduce the fuel consumption to 6% by regulating the tire pressure.

Tires and Wheels Maintenance

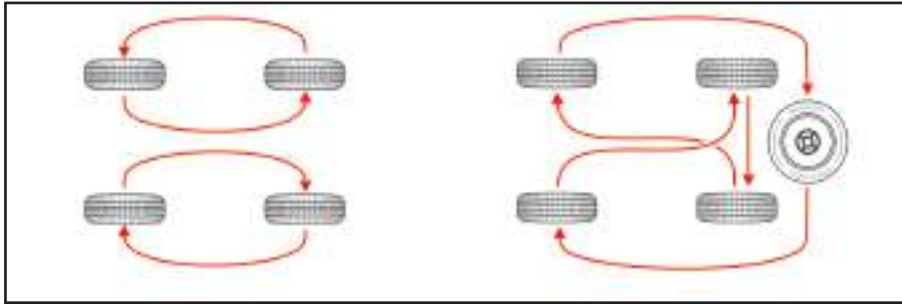

Tire rotation

To keep uniform wear of the tires, it is recommended that rotate the tires every 10.000 kilometers driving.

If there is unusual wear, rotate the tires as soon as possible. Check tire balances after rotating. Also check to see if there is non-uniform wear.

Mostly, unusual wear occurs due to unsuitable tire pressure, misalignment of the wheels and unbalancing the tires, sudden brakes or sharp turns, and hot rings.

Notice that there is no bump on the tread or both sides of the tire.

If you see any above mentioned indications, replace the tires.

After rotating the tires, check their pressure to be adjusted at the specified limit and tighten their nuts.

Whenever you rotate the tires, check the wear of brake linings.

Note

Rotate radial tires that have an asymmetric tread pattern or a directed one, with the tire in the same side.

Tires and Wheels Maintenance

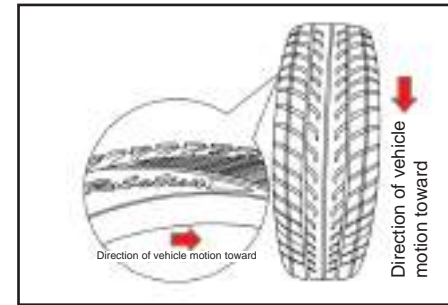

Wheel alignment and tire balancing

In addition to setting tire pressure, alignment the wheels reduces the tire wear. Wheel alignment of the vehicle must be carried out every 24 months or every 20.000 kilometers.

Your tires were balanced in the factory, but they might need rebalancing. If you notice vibration while driving, take your vehicle to an authorized SAIPA YADAK company agent for inspection of the wheels.

Any time you pull out the tire from the ring, you have to balance the tire again.

Note

When replacing the tires, do not use different kinds of tires simultaneously (such as radial, bias and ...) and be careful all the four tires of the vehicle to be at the same size, design, and type. Only use the tires recommended by the factory.

In the vehicles with directional tread tires, the tires should be installed such that the direction of tread stays at the same direction of vehicle motion toward the front. In this condition when you look at the vehicle from the front, you will see tread as V or Y shape.

Tires and Wheels Maintenance

Replacing wheels

When replacing the wheels ensure that they have the diameter, width, external projection from the body, and other specifications according to the factory recommendations.



Note

- Using any type or size of tire other than the one recommended by the factory can strongly affect driving, the vehicle control, the gap size of the vehicle from the surface, and the mileage accuracy.
- Driving with worn tires is very dangerous due to reduction of brakes power, steering wheel accuracy, and traction.
- The best procedure of replacing tires is replacing them simultaneously for all four wheels. If it is impossible to do so, replace front tires and rear tires simultaneously. Notice that replacing only one tire can greatly affect the vehicle driving handling.



Caution

If the wheel size is not proper, it can undesirably affect the wheel life time and its ball bearings, the brakes power and applying the brakes, vehicle handling, and vehicle space from the surface, the tire gap from the body, the tire chain gap from the body, mileage accuracy, beam direction of head lamps, and the bumpers height.

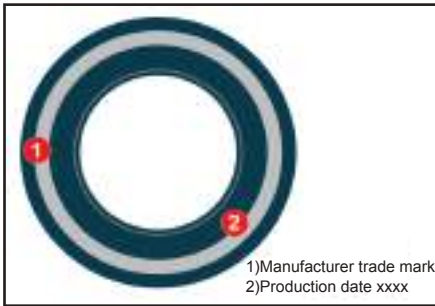

Tire service life

The time of tires making is engraved on the tire's edge by 4 digits number. 2 digits in left indicate week of making time and 2 digits in right indicate year of making time.

For example: 3010 means 30th week of making time in 2010

In a general rule a tire life time is not more than 6 years (even that tire appearance is well) and do not drive by this tire spare tire include of this rule.

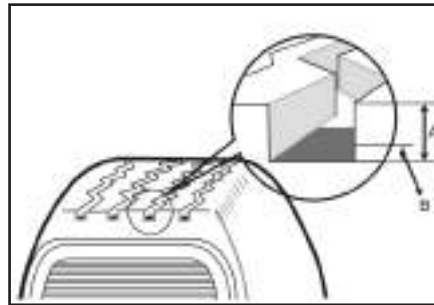

Tire change time and wear indicators
Tires fitted on the vehicle have wear indicators molded into the tread pattern at several points around the circumference. When the tread has worn down, the indicators will come to the surface of the tread pattern. The wear indicators in the pattern show when the tires has reached its safety limit. For safety it must be replaced.

When the tiers and their crowns and sidewalls to find distortions (especially lumps and cuts), they must be replaced untimely.

Bulbs Replacement



Front fog lamp*

For replacing this lamp, bring out the lamp from the out part of the bumper as shown in the figure.

- 1) Close
- 2) Open

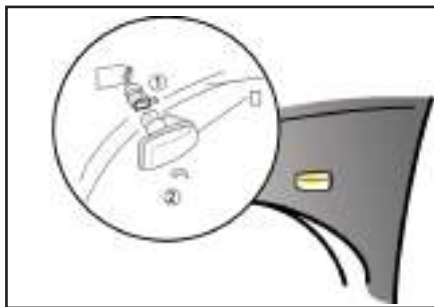

Fender indicator lamp



Room lamp

Remove the room lamp lens by screwdriver and replace the lamp. After replacing the lamp, put the lens on its place.

* According to car model.

Bulbs Replacement



Rear lamp for SAIPA 111

Replace the lamp by opening the rear lamp cover placed in the trunk, according to the figure.

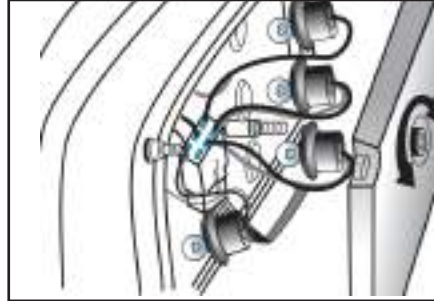

Rear lamp for SAIPA 131 and SAIPA 132

Replace the lamp by opening the rear lamp cover placed in the trunk. Tighten the rear lamp set after replacing.

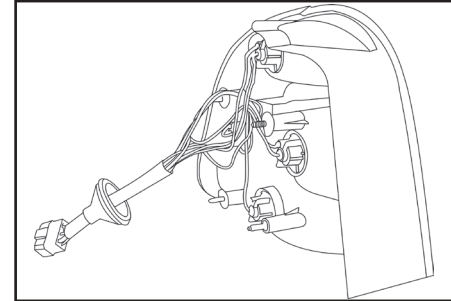

Rear lamp for SAIPA 141

Replace the lamp by opening the rear lamp cover placed in the trunk. Tighten the rear lamp set after replacing.

Bulbs Replacement



License plate lamp for SAIPA 132

Remove the license plate lamp lens by a screwdriver and then replace the lamp. Put the lens on its place after replacing the lamp.

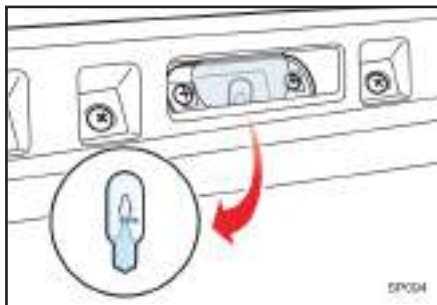

License plate lamp for SAIPA 111, SAIPA 131 and SAIPA 141

Remove the license plate lamp lens by a screwdriver and then replace the lamp. Put the lens on its place after replacing the lamp.



Rear fog lamp 111

Extract the rear fog lamp lens after opening the screws and replace the lamp.

Bulbs Replacement



Front lamp for SAIPA 111 and SAIPA 132

Refer to the authorized agent for replacing this lamp.

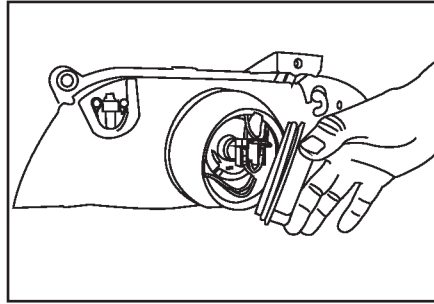

Front lamp for SAIPA 131 and SAIPA 141

Refer to the authorized agent for replacing this lamp.



Third stop lamp

Extract the third stop lamp assembly from the fifth door after opening the rear nuts of this lamp and replace it.

Oils Replacement

Recommended oils

To have an engine and power train with a proper performance, constant power, and long life time, only use good quality engine oil. This improves the engine efficiency and fuel economy. The oils recommended here can only be used in this vehicle.

Notice to the viscosity numbers proposed by SAE standard in this table.



Note

Using the oil with qualified specifically and changing it periodically causes increasing engine component life time and preventing from damage. Therefore use the oil confirmed by SAIPA with SAIPA logo which is set to IRAN air condition and is purchased in all authorized SAIPA YADAK agents. Non-standard engine oil will disperse the guaranty.

Lubricant/Application	Fluid type
Engine oil	API service: SG 20W50
Transmission fluid	API service:GL4- GL5 SAE:75W80
Brake fluid	SAE J1703 Dot 3
High temperature grease	NLGI NO.2
*Power steering oil	DEXRON II PSF-III

* According to car model.

General Warning

Notice that following the manufacturer's recommendations the time of using different detergents and polishing chemicals are most important.

Take into account all the warnings and cautions written on the tags.

Vehicle body surface protection Washing

To protect the vehicle body from corrosion and damage, wash the vehicle body with cold water at least one time per month.

Make sure to clean any dirt and dreg such as salt, mud, and so on.

Ensure that all the drain holes on the vehicle floor and on the lower edge of the doors are cleaned.

Insects, pitch, gum, bird dropping, and any other dirt must be cleaned immediately from the vehicle body surface. Otherwise, they can damage the body.

If you wash the body surface with plain water without using detergent,

it is possible the dirt is not cleaned completely. In this case, use a mild soap which is for vehicle washing.

Note

For washing the vehicle body does not use strong soap, chemical detergents, and hot water. Also do not wash the vehicle in direct sunlight or when the body is hot.

Be careful that no detergent is left on the vehicle body after washing the vehicle. For this reason, wash the vehicle body surface with cold or lukewarm water totally.

Caution

Washing the engine compartment with water may cause some trouble in the electrical circuits. Therefore, be careful when washing the engine compartment with water.

Environment and vehicle

Help the beauty of the urban environment by cleaning the vehicle and considering its paint.

Vehicle paint

One of the most important pollution of the vehicle paint is chromium. Therefore, be careful about leakage to the soil and water when using paints especially in workshops.

Vehicle Body Protection



Caution

After washing the vehicle, while driving carefully and slowly apply the brake to check if its performance is not affected by wet. If the brake linings are wet, to dry them apply the brakes slowly while driving the vehicle at low speed.

Body wax

Before waxing, wash the vehicle body and start waxing when there is no water droplet left on the body.

Use solid or liquid polish with a better quality based on the manufacturer's recommendations.

Polish all the metal parts of internal trim to protect their surfaces.

Cleaning the oil, dirt, and so on from the body by regular cleaning brushes may remove the polish from that part of the body. Therefore, make sure to polish the cleaned parts of the body (even though there is no need to polish the other parts).



Note

- Cleaning dust and dirt with a dry cloth from the body can cause scratch on the body paint.

- Do not use wire brushes, corrosive detergents, strong detergents with active chemicals, and aluminum anode parts for washing the vehicle. Otherwise, it is possible the protective coating and the paint to be damaged.

Vehicle body damage repair

Deep scratches or cuts on the surface paint of the vehicle must be repaired immediately. Otherwise, the parts without paint will be corroded and the growth of the corrosion depth will increase the repair costs.

Note

If your vehicle body is damaged and it needs to be repaired, make sure the corresponding body workshop to apply the anti-corrosion coating on the repaired or replaced parts.

Cleaning underbody

Although underbody is coated by anti-corrosion material, the corrosive materials on the roads to melt snow and ice or to control the dust can cause rapid corrosion of fuel piping system, exhaust system, underbody tray, and oil pan.

To prevent from this, wash underbody every month and specially at the end of winter with cold or lukewarm water. Wash it more carefully because different parts of underbody are not easily visible to detect the defected part.

There are drain holes on the floor and lower edge of the doors. They must be kept open to easily drain the water; otherwise the water can cause corrosion.

Notice that if you do not dry and clean the underbody, worse condition can occur.

Caution

After washing the vehicle you have to drive slowly and apply the brake to dry the brake linings.

Protection of the Vehicle Interior Trims

General warning

Be careful not spill perfume or cosmetic cream over the dashboard. This can cause damage the dashboard color. If anything spills over the dashboard, clean it immediately.

Interior fabric trim

First remove dust from fabric trim using a broom or vacuum cleaner and then wipe the fabric by the special carpet shampoo.

Clean any stains from the fabric immediately using stain removal detergent. If you do not wipe out the stains immediately from the fabric, they stay on the fabric and may change its color.



Caution

Using no recommended detergents or cleaning method can cause damage to the fabric and to its anti-fire property.

Cleaning vehicle windows

If the vehicle windows' surfaces are covered by a layer of grease, oil, or polishing material, it can destroy the proper vision. The windows must be cleansed with a suitable glass cleaner. To do so, follow the instructions written on the detergent box.



Note

When cleaning the interior surface of the rear window do not use a sharp object or scratch it. This can damage the element of the rear window defrost



Environment and vehicle

Vehicle air condition

One of the most important pollution of the air condition systems is the destroyer gases of the ozone layer (like the Freon gas). Fortunately, the R134 gas is used in the SAIPA products instead of destroyer gases that have no destructive effect of the ozone layer.

Thermostat

The appropriate performance of thermostat causes engine performance in optimized temperature and 2% economy in fuel consumption.

The fuel in fuel tank vaporizes and propagates when facing free atmosphere because of its nature. Fuel vapor propagation causes air pollution. In order to solve this problem, there should be an assembly, which has the ability of absorbing and recovering the fuel vapor. This procedure is done by the canister in the

vehicles. The fuel vapor is transmitted to the canister through the hose and the active layers of carbon are absorbed when passing the canister. The canister has the effect of reducing the environment pollution by recovering and consuming the fuel vapor. It has a sensible effect because of preventing the propagation of toxic gases to the environment. The replacement time of the canister is the standard time of the automotives if the result of the performance test in the technical examination center of the vehicles is negative, 30000 kilometers in general condition and 24 month after installation.



Chapter 8

First Service and Vehicle Guarantee	174
Periodical Services	179



First Service and Vehicle Guarantee

Vehicle Guarantee

Any vehicle is under guarantee by SAIPA YADAK Company according to the elapsed time and mileage that is written on your guarantee card and due to performing first and periodical services on its time, according to the conditions stated hereinafter.

First service:

The first service of periodical services is called first service. Performing the first service is mandatory between 4500 to 5500 Km of vehicle mileage or 6 months (which one arrives first) after the warrantee issuance date. Warrantee is invalid if first service was not performed between time and mileage limitations mentioned above.

Remark 1: primary services perform only once a time.

Remark 2: performing the primary service is free but the customer should pay about the material used.

Periodical services

Performing Periodical services according to the table of this manual is mandatory and not performing the services in the authorized dealerships of SAIPA, causes cancelling the vehicle warrantee.

Vehicle Service Card

VehicleServiceCard is presented to customer in delivery time. This card is double proposed (service and banking) in order to conservation of any repair documents.

8

Remark 1: Having this card to refer the authorized agents of SAIPA YADAK Company is mandatory.

Remark 2: Vehicle Service Card is intact when presented to customer. The customer should pay the cost of replica due to any physical problem and system conflict in this card

First Service and Vehicle Guarantee

Followings are not covered by guarantee:

1- Normal vehicle exhaustion (it means the damages of non-execution of appropriate repair and maintenance and periodical inspections, exhaustion of tires and consumable parts such as fuses and lamp)

2- Periodic services, maintenances and services and regular inspections costs

Remark: primary service is free of charge for the customer.

3- Any kind of damages that is not related to the vehicles structure such as: car accidents, stone strike, abrasion, theft, firing and natural calamity and catastrophe, war, anarchy and revolution.

4- Parts are covered by guarantee as consumable materials such as engine oil and transmission fluid, hydraulic fluid, brake fluid, cooler gas, cooling fluid, battery fluid, air filter and oil filter, and consumable parts such as brake linings and brake pads, clutch cover, belts, caps and plug, fuses, windshield wiper blade, tire(except consumable parts) that are under supplier guarantee.

Remark: replacement of consumable parts that are damaged by the vehicles fault is the supplier's task and is under guarantee.

Note: the above mentioned parts are not covered by warranties if they were not affected by any defects and the damage is caused only by the depreciation.

First Service and Vehicle Guarantee

Guarantees failure conditions

Warning

Conditions that cause injury of passenger

Some customers install an oilcloth under the mat floor to keep the vehicle floor clean. In order to set this cover the seats and safety belts must be disassembled and re-assembled, in this way, the proper torque for fastening the screws is not observed. It has been seen that during an accident this will cause injury to the passengers.

Conditions that cause firing of vehicle

- 1- While covering vehicle seat, wiring assembly may place between connections and vehicle body and cause firing.
- 2- While installation of anti-theft systems, changing in electrical circuits may cause firing.
- 3- use of non-standard parts such as: fuses, speakers, rear and front lamps, indicator lamps and ...
- 4- Use of non-standard parts in lighter cigar's place such as FM modulator, air infiltration apparatus, and chargeable lamps that causes firing.

Under the following conditions the vehicle guarantee will be eliminated and the company will not have any obligation.

- 1- Using the parts which are not recommended by SAIPA YADAK Company.
- 2- Any modification without permission of SAIPA YADAK Company.
- 3- If you do not follow the instructions regarding the periodic service intervals and recommended actions (refer to periodic service list).
- 4- Any changes in wiring and electrical circuit (such as luck switch of speedometer, changes caused by anti-theft installation and ...)
- 5- Any damage or injury from replacing or installing parts in the auxiliary system and maintenance service out of SAIPA YADAK company network is out of guarantee conditions and there is no right for customer and others against SAIPA corporations and SAIPA YADAK Company.
- 6- If the speedometer system is touched so that the traveled distance cannot be recognizable.
- 7- Any changes in electronic and electrical vehicles system such as anti-theft installation, audio systems and changes in wiring that cause damage in vehicle performance.
- 8- Changing the body complete after severe accident.

Limitations of Vehicle Guarantee

- 1- Guarantee services are limited to renovation and replacement of damaged part that SAIPA YADAK Company should pay its cost. Also SAIPA YADAK Company is responsible for identifying the damage of parts and deciding about to repair or to replace them.
- 2- Replaced parts belong to SAIPA YADAK Company in guarantee period.
- 3- Repairing or replacement of vehicles parts cannot extend the guarantee period.
- 4- Consumable parts have guarantee limits as followings:
 - a) Clutch kit except clutch cover, battery, windshield wiper motor less than one year or 24000 km of vehicle travel guarantee whichever comes first.
 - b) Brake linings and brake pads, clutch cover, windshield wiper blade less than 3 months or 6000 km of vehicle travel guarantee whichever comes first.

Vehicle Paint Guarantee

Your vehicle has 3 years paint guarantee. If you see any change in color of the paint such as fallout, twofold color, flaking, consult immediately the vehicle supplier.

Remark 1: The painted parts such as bumpers, grills, dashboard, and so on are only covered until the end of vehicle guarantee.

Remark 2: Paint damage resulting from the chemical fallout and improper vehicle usage is not covered by the vehicle guarantee.

Remark 3: Removing oil stains by pressurized washing tools or unrecompensed detergents from the mechanical parts, underbody, hinged parts and exterior plastic parts, are not recommended.

First Service and Vehicle Guarantee

First service and guarantee

Recommended services in this manual are advised by the vehicle's factory and performing First and periodically services, help you in maintaining your vehicle in best condition.

First service operations:

- 1- Changing the engine oil (simultaneous with the first Periodical service and by customer charge)
- 2- Replacing the oil filter (simultaneous with the first Periodical service and by customer charge)
- 3- Changing the gearbox oil (simultaneous with the first Periodical service and by customer charge)
- 4- Inspecting the condition of Engine and ABS system by diagnostic tool.
- 5- Head cylinder, inlet and outlet manifold nuts and bolts tightening up.
- 6- Inspection of cooling system.
- 7- Checking the condition of fuel tank, pipes, hoses and respective bands and clamps.
- 8- Inspecting the Battery acid viscosity (quality check) and related connections
- 9- Inspection of fuses and fuse box
- 10- Inspecting the performance of electrical systems.
- 11- Controlling the performance of windshield wiper.
- 12- Inspection and adjusting of valves clearance
- 13- Inspection of brake performance and checking the brake fluid level
- 14- Inspection and adjusting the parking brake
- 15- Inspection and torque checking of safety connections (according to attached list)
- 16- Inspection of clutch pedal clearance and adjusting clutch cable
- 17- Inspection of accelerator pedal and accelerator cable
- 18- Inspection of power steering
- 19- Inspecting suspension system and condition of the shock absorbers.

First Service and Vehicle Guarantee

- 20- Inspection and adjusting of belts (air conditioning and alternator belts) if necessary
- 21- Inspection of air conditioning system
- 22- Inspecting the functionality of door openers (hood, tailgate, trunk lid)
- 23- Inspection of compartment interior appearance
- 24- Inspection of tires, rings and spare tire
- 25- Inspection of gaskets.
- 26- Visual inspection of vehicle body.
- 27- Inspection of doors function (regulation function)
- 28- Inspection of safety belt fastener, seat and seatback adjustment and headrest safety lock

Periodical Services chart for SAIPA family (111, 131, 132, 141)

SERVICE TIME PERIODS	Number of month or distance value (km), anyone which occurs earlier								
	Month	6	12	18	24	30	36	42	48
SERVICE TYPE	in 1000 km	10	20	30	40	50	60	70	80
Engine valve clearance			inspection		inspection		inspection		inspection
Intake and exhausted manifold bolts					inspection				inspection
Timing belt									
Drive belts	inspection	inspection	inspection	replacement	inspection	inspection	inspection	inspection	replacement
Engine oil									
Engine oil filter									
Cooling system	inspection	inspection	inspection	inspection	inspection	inspection	inspection	inspection	inspection
Cooling liquid									
Fuel lines and hoses	inspection	inspection	inspection	inspection	inspection	inspection	inspection	inspection	inspection
Air cleaner filter									
Fuel filter									
Spark plugs									
Electrical systems	inspection	inspection	inspection	inspection	inspection	inspection	inspection	inspection	inspection
Battery condition	inspection	inspection	inspection	inspection	inspection	inspection	inspection	inspection	inspection
Clutch pedal	inspection	inspection	inspection	inspection	inspection	inspection	inspection	inspection	inspection
Brake lines, hoses & connection	inspection	inspection	inspection	inspection	inspection	inspection	inspection	inspection	inspection
Brake pedal	inspection	inspection	inspection	inspection	inspection	inspection	inspection	inspection	inspection

Periodical services

SERVICE TYPE	SERVICE TIME PERIODS	Number of month or distance value (km), anyone which occurs earlier								
		Month	6	12	18	24	30	36	42	48
		in 1000 km	10	20	30	40	50	60	70	80
Brake fluid		Inspection	Inspection	Inspection	Inspection	Inspection	replacement	Inspection	Inspection	
Parking brake		Inspection	Inspection	Inspection	Inspection	Inspection	Inspection	Inspection	Inspection	
Ball bearing and loosening of front and rear wheels			Inspection		Inspection		Inspection		Inspection	
Front disk brake		Inspection	Inspection	Inspection	Inspection	Inspection	Inspection	Inspection	Inspection	
Rear drum brake			Inspection		Inspection		Inspection		Inspection	
Steering control joints		Inspection	Inspection	Inspection	Inspection	Inspection		Inspection	Inspection	
Exhaust system		Inspection			Inspection					
Operation of steering system		Inspection	Inspection	Inspection	Inspection	Inspection	Inspection	Inspection	Inspection	
Gearbox oil		Inspection	Inspection	Inspection	replacement	Inspection	Inspection	Inspection	replacement	
Drive shaft dust boot			Inspection		Inspection		Inspection		Inspection	
Tire (pressure & tread wear)		Inspection	Inspection	Inspection	Inspection	Inspection	Inspection	Inspection	Inspection	
Suspension system, shock absorbers			Inspection		Inspection		Inspection		Inspection	
Safety belts			Inspection		Inspection		Inspection		Inspection	
All lamps and warning lamps		Inspection	Inspection	Inspection	Inspection	Inspection	Inspection	Inspection	Inspection	
Horn, arm and blade wiper windshield washer		Inspection	Inspection	Inspection	Inspection	Inspection	Inspection	Inspection	Inspection	
Air conditioning system		Inspection	Inspection	Inspection	Inspection	Inspection	Inspection	Inspection	Inspection	

Periodical Services

SERVICE TYPE	SERVICE TIME PERIODS	Number of month or distance value (km), anyone which occurs earlier							
		Month	6	12	18	24	30	36	42
	KM×1000	10	20	30	40	50	60	70	80
Power steering and hoses		inspection		inspection		inspection		inspection	
Power steering fluid		inspection	inspection	inspection	inspection	inspection	inspection	inspection	inspection
Anti-lock braking system (ABS)		inspection	inspection	inspection	inspection	inspection	inspection	inspection	inspection

NO.	Maintenance item	Maintenance operation	Maintenance intervals	Driving conditions
1	Engine oil and oil filter	Replace	Each 5000km or 6 month	A,B,C,F,H
2	Air cleaner filter	Replace	Prior to the normal date	C,E
3	Timing belt	Replace	80,000km	F
4	Spark plugs	Replace	Prior to the normal date	B,H
5	Gearbox oil	Replace	Each 30,000km	C,D,E,G,H,I

A: Repeated short distance driving

C: Driving in dusty rough roads

E: Driving in sandy areas

G: Driving in mountain areas

I: Driving by patrol car, commercial car or vehicle towing

B: Extensive Idling

D: Driving in areas using salt or other corrosive materials or in very cold weather

F: More than 50% driving in heavy city traffic during hot weather above 32°C (90°F)

H: Towing a trailer

8

Bi fuel powered vehicle primary and periodic services

- Controlling high pressure gas pipe (at least every 6 month)
- Inspecting CNG kit stepper motor
- CNG tank and holder frame control and tightening up all relevant nuts and bolts of needed
- CNG high pressure ventilation ducts control
- Inspecting CNG regulator
- Inspecting CNG sockets system
- Inspecting low pressure gas system bands (from regulator to mixer)



CHAPTER 9

9



Vehicle
Specifications

Lamps for SAIPA 111

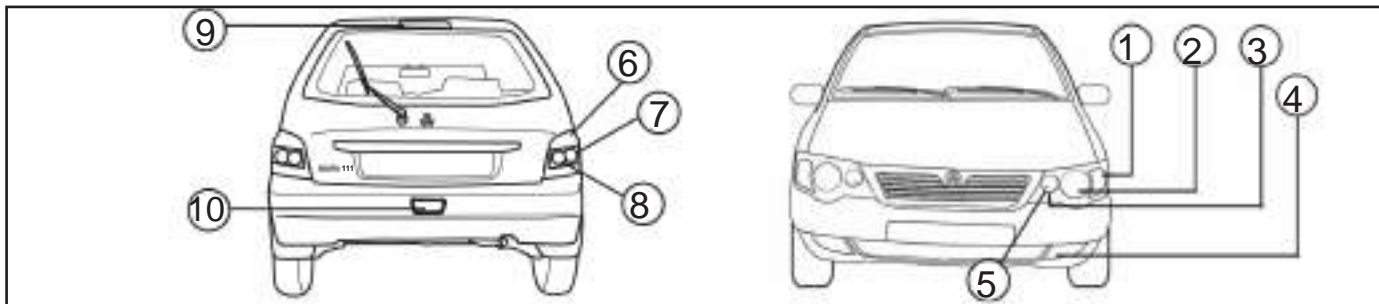

- 1- Front turn signal lamp
- 2- Front lamp dim light
- 3- Front lamp headlight
- 4- Front fog lamp
- 5- Front park lamp
- 6- Rear stop lamp
- 7- Rear turn signal lamp
- 8- Reverse lamps
- 9- Third stop lamp
- 10- Rear fog lamp

Replacing lamps

Note

Inspect the function of all external lamps before driving.
Turn off the lamps before replacing to prevent short circuit.

Lamps	power (w)
Front lamp dim light	55
Front lamp headlight	55
Front park lamp	5
Front fog lamp	27
Rear fog lamp	16
Front turn signal lamp	21
side turn signal lamp	5
Rear stop lamp	5-21
Rear turn signal lamp	21
Reverse lamp	21
rear license plate lamp	5
Third stop lamp	5

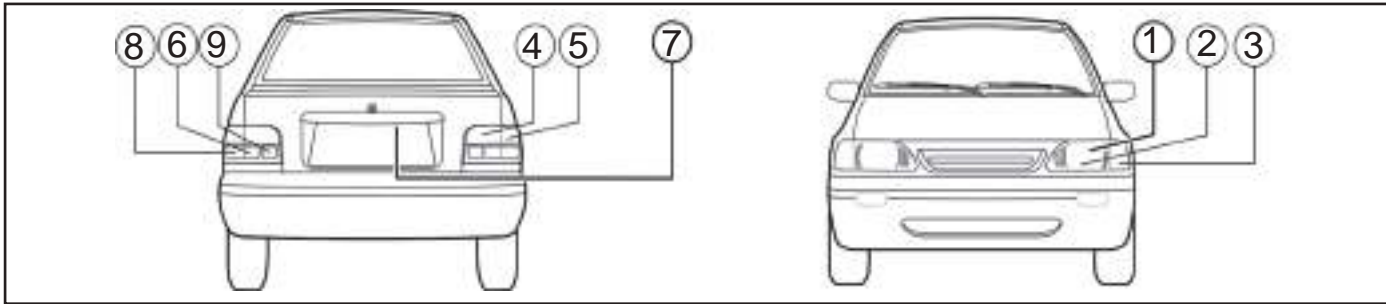

- 1- Front lamp
- 2- Front park lamp
- 3- Front turn signal lamp
- 4- Stop lamp
- 5- Rear lamp
- 6- Reverse lamp
- 7- License plate lamp
- 8- Rear turn signal lamp
- 9- Rear fog lamp

Replacing lamps

Note

Inspect the function of all external lamps before driving.
Turn off the lamps before replacing to prevent short circuit.

Lamps	power (w)
Front lamp dim light	55
Front lamp headlight	55
Front turn signal lamp	21
Front park lamp	5
Rear turn signal lamp	21
Rear fog lamp	21
Reverse lamp	21
Room lamp	10
Trunk lamp	5
Rear lamp	5
rear license plate lamp	5
Third stop lamp	5

Lamps for SAIPA 132

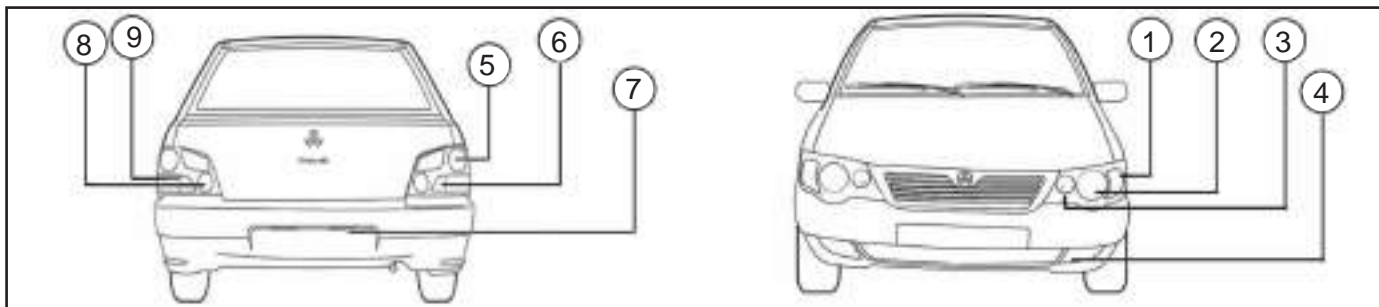

- 1- Front turn signal lamp
- 2- Front lamp dim light
- 3- Front lamp headlight/park lamp
- 4- Fog lamp
- 5- Stop lamp
- 6- Reverse lamp
- 7- License plate lamp
- 8- Rear Fog lamp
- 9- Rear turn signal lamp

Replacing lamps

Note:

Inspect the function of all external lamps before driving.
Turn off the lamps before replacing to prevent short circuit.
Refer to the authorized agent for replacing front lamps.

Lamps	power (w)
Front lamp dim light	55
Front lamp headlight	55
Front turn signal lamp	21
Front park lamp	5
Rear turn signal lamp	21
Rear fog lamp	21-21.5
Reverse lamp	21
Room lamp	10
Trunk lamp	5

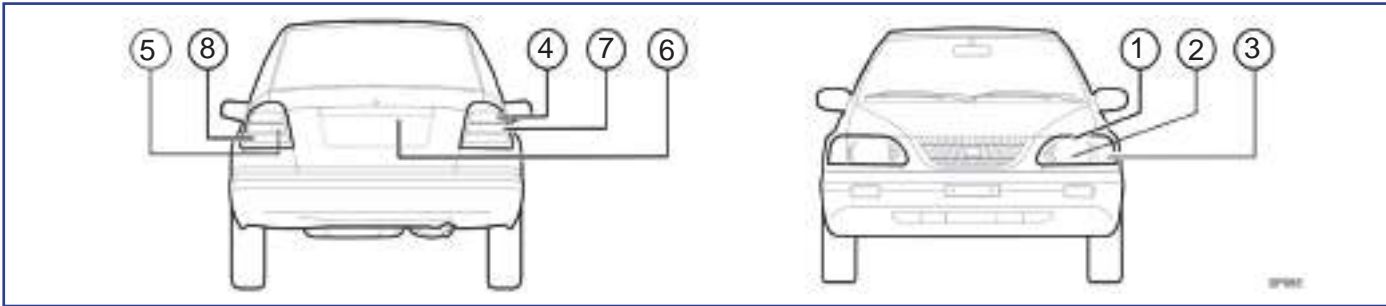

- 1- Front lamp
- 2- Front park lamp
- 3- Front turn signal lamp
- 4- Rear lamp/ stop lamp
- 5- Reverse lamp
- 6- License plate lamp
- 7- Rear turn signal lamp
- 8- Rear Fog lamp

Replacing lamps

Note:

Inspect the function of all external lamps before driving.
 Turn off the lamps before replacing to prevent short circuit.
 Refer to the authorized agent for replacing front lamps.

Lamps	power (w)
Front lamp dim light	55
Front lamp headlight	55
Front turn signal lamp	21
Front park lamp	5
Rear turn signal lamp	21
Rear fog lamp	21-21.5
Reverse lamp	21
Room lamp	10
Trunk lamp	5

Technical Information

Engine

Model	Injector
Engine type	Petrol-four stroke
NO. of cylinders	linear 4
Cylinder bore	71mm
Piston stroke	83.6mm
Engine volume	1323cc
Compression ratio	9.7:1
Firing order	1-3-4-2
Maximum engine power	63 hp @ 5500rpm for gasoline 69.03 hp @ 5000rpm for improved gasoline engine 60.5 hp @ 5500rpm for gas-based engine- in gas status 68 hp @ 5000rpm for gas-based engine- in petrol status
Maximum torque	103.3 N.m @ 2800rpm for gasoline 109 N.m @ 3000rpm for improved gasoline engine 100.9 N.m @ 2750rpm for gas-based engine- in gas status 108 N.m @ 3000rpm for gas-based engine- in petrol status
Fuel type	Gasoline standard Euro 4
Valve system	Single head camshaft

Fuel charging system

Type	Injector with ECU
Fuel pump type	Electrical

Electric system

Alternator voltage and amperage	12V-65A
Battery voltage	12V nominal
Starter	Magnetic(12V-0.85KW)

Power transmission system

Clutch type	Single disk dry clutch with diaphragm spring
Gearbox	5 gears
First gear	Gear ratio3.454
Second gear	Gear ratio1.944
Third gear	Gear ratio1.275
Fourth gear	Gear ratio0.861
Fifth gear	Gear ratio0.692
Reverse	Gear ratio3.583
Final gear	Gear ratio3.778

Brake system

Type	Master vacuum hydraulic brake
Front brakes	Disc
Rear brakes	drum

Technical Information

Wheels and chassis

Type	Integral body and frame construction
Wheel rim size	4.5J×13(steel) - 5J×13(aluminum)
Tire size	175.60 R13(Alumina rim) - 165.65 R13(Steel rim*)
Front wheels air pressure	29Psi or 2cm2/kg
Rear wheels air pressure	29Psi or 2cm2/kg
Vehicle minimum turning radius	4.55m

Steering system

Type	Rack and pinion
Steering wheel type	Collapsible type

Suspension system

Front suspension	Mack Ferson- coil spring
Rear suspension	Torsion axel- coil spring
Front and rear damper	Hydraulic- telescopic

Capacities

Engine oil- oil filter excluded (oil filter included)	3L (3.4L)
Hydraulic oil	875 cc
Engine coolant	5 L
Fuel tank	37 L

* According to car model.

Filters

Oil filter	Paper type
Air filter	Paper type
Fuel filter	Paper type

Seats

Front seat	back seat with adjustable back set and headrest
Rear seat	Fixed back seat and no headrest

Weights*

Net weight 111	905 kg
Net weight 131	915 kg
Net weight 132	920 kg
Net weight 141	940 kg
Maximum allowed vehicle load	400 kg
Seating capacity for passenger and driver	4 people
Front seats capacity	2 people
Rear seats capacity	2 people

*in bi-fuel vehicle the net weight is increased 80kg

Technical Information (SAIPA 111)

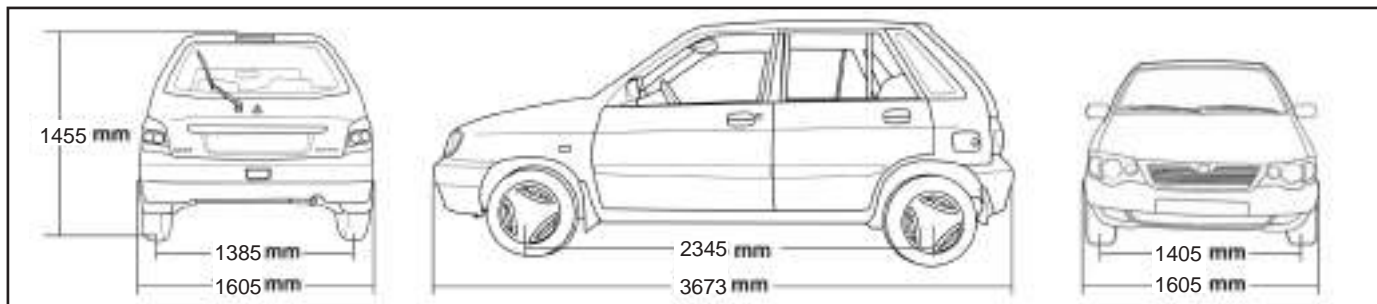

Vehicle length	3673 mm
Vehicle width	1605 mm
Height	1455 mm
Axels 'center axis distance	2345 mm
Front wheel center axis distance	1405 mm
Rear wheel center axis distance	1385 mm

Technical Information (SAIPA 131)

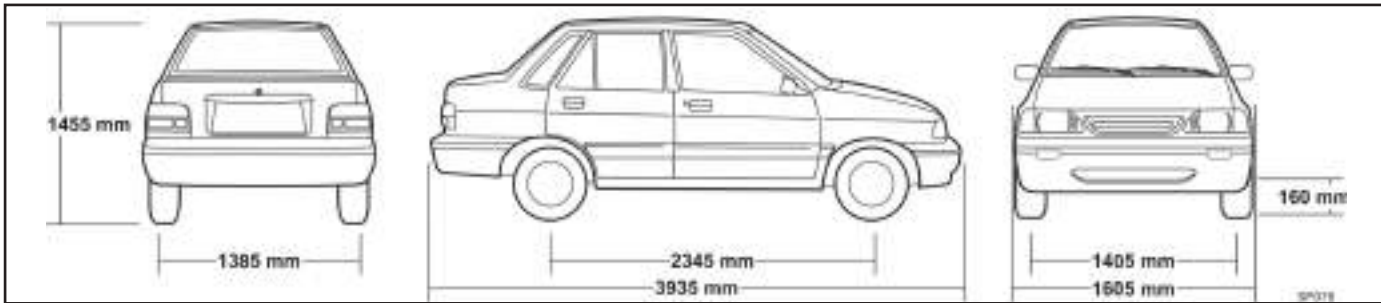

Vehicle length	3935 mm
Vehicle width	1605 mm
Height	1455 mm
Axels 'center axis distance	2345 mm
Front wheel center axis distance	1405 mm
Rear wheel center axis distance	1385 mm
Minimum ground clearance (under step)	160 mm

Technical Information (SAIPA 132)



Vehicle length	3952 mm
Vehicle width	1605 mm
Height	1455 mm
Axels 'center axis distance	2345 mm
Front wheel center axis distance	1405 mm
Rear wheel center axis distance	1385 mm
Minimum ground clearance (under step)	160 mm

Technical Information (SAIPA 141)

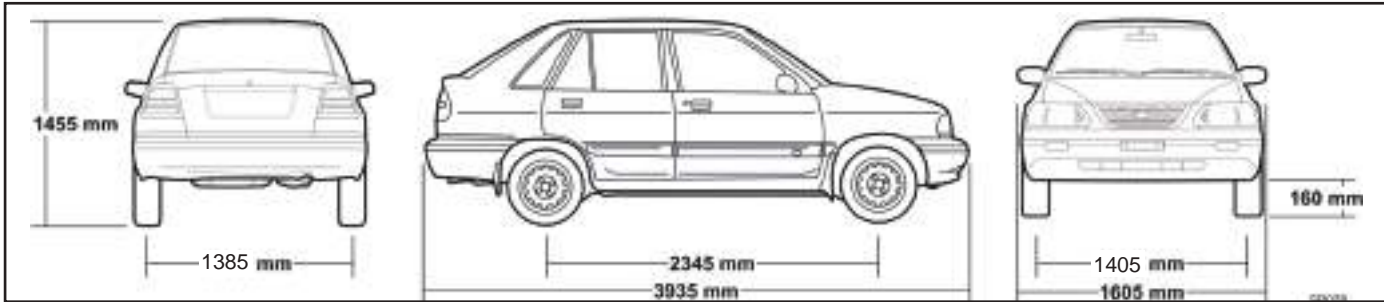

Vehicle length	3935 mm
Vehicle width	1605 mm
Height	1455 mm
Axels 'center axis distance	2345 mm
Front wheel center axis distance	1405 mm
Rear wheel center axis distance	1385 mm
Minimum ground clearance (under step)	160 mm