



AEROSTAR

Your satisfaction is our #1 goal. If you have questions or concerns with your vehicle, we suggest you follow these steps:

1. Contact your Sales Representative or Service Advisor at your selling/servicing dealership.
2. If the inquiry or concern remains unresolved, contact the Sales Manager or Service Manager at the dealership.
3. If the inquiry or concern cannot be resolved at the dealership level, please contact the Ford Customer Assistance Center.

In the United States:

Ford Motor Company
Customer Assistance Center
300 Renaissance Center
P.O. Box 43360
Detroit, MI 48243
1-800-392-3673 (FORD)
TDD for the hearing impaired: 1-800-232-5952

In Canada:

Customer Assistance Centre
Ford Motor Company of Canada, Limited
P.O. Box 2000
Oakville, Ontario L6J 5E4
1-800-565-3673 (FORD)

Outside the U.S. or Canada:

FORD MOTOR COMPANY
WORLDWIDE EXPORT OPERATIONS
1555 Fairlane Drive
Fairlane Business Park #3
Allen Park, Michigan 48101
Telephone: (313) 594-4857
Fax: (313) 390-0804



All rights reserved. Reproduction by any means, electronic or mechanical, including photocopying, recording, or information storage and retrieval system or translation, whole or part is not permitted without written authorization from Ford Motor Company.

Copyright © 1996 Ford Motor Company

Table of Contents

| | |
|-----------------------------------------------|-----|
| Introduction | 1 |
| Instrumentation | 7 |
| Audio | 21 |
| Controls and Features | 59 |
| Seating and Safety Restraints | 97 |
| Starting | 153 |
| Driving | 163 |
| Roadside Emergencies | 199 |
| Maintenance and Care | 229 |
| Capacities and Specifications | 293 |
| Reporting Safety Defects (U.S. Only) | 301 |
| Customer Assistance | 303 |
| Accessories | 315 |
| Quick Index | 327 |
| Index | 335 |
| Service Station Information | 356 |

Introduction

Ford's Commitment to You

At Ford Motor Company, excellence is the continuous commitment to achieve the best result possible. It is dedication to learning what you want, determination to develop the right concept, and execution of that concept with care, precision, and attention to detail. In short, excellence means being the standard by which others are judged.

Our Guiding Principles

- Quality comes first.** For your satisfaction, the quality of our products and services must be our number one priority.
- You are the focus of everything we do.** Our work must be done with you in mind, providing better products and services than our competition.
- Continuous improvement is essential to our success.** We must strive for excellence in everything we do: in our products — in their safety and value — and in our services, our human relations, our competitiveness, and our profitability.
- Employee involvement is our way of life.** We are a team. We must treat one another with trust and respect.
- Dealers and suppliers are our partners.** We must maintain mutually beneficial relationships with dealers, suppliers, and our other business associates.

- ❑ **Integrity is never compromised.** Our conduct worldwide must be pursued in a manner that is socially responsible and commands respect for its integrity and for its positive contributions to society.

NOTES and WARNINGS

NOTES give you additional information about the subject matter you are referencing.

WARNINGS remind you to be especially careful in those areas where carelessness can cause damage to your vehicle or personal injury to yourself, your passengers or other people. Please read all **WARNINGS** carefully.

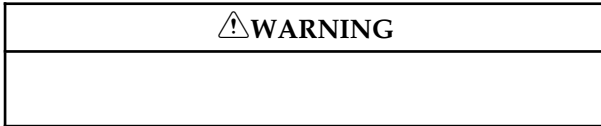

Finding Information in This Guide

After you have read this guide once, you will probably return to it when you have a specific question or need additional information. To help you find specific information quickly, you can use the Quick Index, Table of Contents, or the Index.

The **Quick Index** at the end of the book provides a page number following each item which indicates where detailed information can be found.

To use the **Index**, turn to the back of the book and search in the alphabetical listing for the word that best describes the information you need. If the word you chose is not listed, think of other related words and look them up. We have designed the Index so that you can find information under a technical term.

Canadian Owners — French Version

French Owner Guides can be obtained from your dealer or by writing to Ford Motor Company of Canada, Limited, Service Publications, P.O. Box 1580, Station B, Mississauga, Ontario L4Y 4G3.

Your Maintenance Schedule and Record Booklet

The *Maintenance Schedule* booklet lists the services that are most important for keeping your vehicle in good condition. A record log is also provided to help you keep track of all services performed.

About the Warranties

Your vehicle is covered by three types of warranties: **Basic Vehicle Warranty**, **Extended Warranties** on certain parts, and **Emissions Warranties**.

Read your *Warranty Information Booklet* carefully to find out about your vehicle's warranties and your basic rights and responsibilities.

If you lose your *Warranty Information Booklet*, you can get a new one free of charge. Contact any Ford or Lincoln-Mercury dealer, or refer to the addresses and phone numbers on the first page of this Owner's Guide.

Ford Extended Service Plan

More Protection for Your Vehicle

You can get more protection for your new car or light truck by purchasing a Ford Extended Service Plan (Ford ESP). Ford ESP is the only extended service program with the Ford name on it and the only service contract backed by Ford Motor Company.

Ford ESP is an optional service contract, backed and administered by Ford. It provides:

- protection against repair costs after your Bumper to Bumper Warranty expires;
- and
- other benefits during the warranty period (such as: reimbursement for rentals; coverage for certain maintenance and wear items).

You may purchase Ford ESP from any participating Ford Motor Company dealer. There are several Ford ESP plans available in various time-and-mileage combinations. Each plan can be tailored to fit your own driving needs, including reimbursement benefits for towing and rental. (In Hawaii, rules vary. See your dealer for details.)

When you purchase Ford ESP, you receive peace-of-mind protection throughout the United States and Canada, provided by a network of more than 5,100 participating Ford Motor Company dealers.

NOTE: Repairs performed outside the United States and Canada are not eligible for ESP coverage.

This information is subject to change. Ask your dealer for complete details about Ford ESP coverage.

Special Notice

NOTICE TO OWNERS OF E-4WD VEHICLES

As with other vehicles of this type, failure to operate this vehicle correctly may result in loss of control or an accident. Be sure to read the special driving instructions in the section *Electronic 4-Wheel Drive (E-4WD)* in this book.

Federal Highway Administration Regulation

Regulations such as those issued by the Federal Highway Administration or issued pursuant to the Occupational Safety and Health Act (OSHA), and/or state and local laws and regulations may require additional equipment for the way you intend to use the vehicle. It is the responsibility of the registered owner to determine the applicability of such laws and regulations to your intended use for the vehicle, and to arrange for the installation of required equipment. Your Ford dealer has information about the availability of many items of equipment which may be ordered for your vehicle.

Breaking Your Vehicle In

Your new vehicle goes through an adjustment or break-in period during the first 1,000 miles (1,600 km) that you drive it. During the break-in period, you need to pay careful attention to how you drive your vehicle.

Avoid sudden stops. Because your vehicle has new brake linings, you should take these steps:

- Watch traffic carefully so that you can anticipate when to stop.

— Begin braking well in advance.

— Apply the brakes gradually.

The break-in period for new brake linings lasts for 100 miles (160 km) of city driving or 1,000 miles (1,600 km) of highway driving.

Wheel lug nuts must be retightened to proper torque specifications at 500 miles/800 km of new vehicle operation. Proper torque specifications are provided in the *Roadside Emergencies* chapter. Also retighten to proper torque specifications at 500 miles/800 km after any wheel change or any other time the wheel lug nuts have been loosened.

Use only the type of engine oil that Ford recommends. See *Engine oil recommendations* in the Index. Do not use special “break-in” oils.

Things to Know About Using This Guide

Congratulations on the purchase of your new vehicle. This guide has information about the equipment and the options for your new vehicle. You may not have bought all of the options available to you. If you do not know which information applies to your vehicle, talk to your dealer.

This guide describes equipment and gives specifications for equipment that was in effect when this guide was approved for printing. Ford may discontinue models or change specifications or design without any notice and without incurring obligation.

Instrumentation

The instrument panel (dashboard) on your vehicle is divided into several different sections. The illustrations on the following pages show the major parts of the instrument panel that are described in this chapter. Some items shown may not be on all vehicles.

In your vehicle, the warning lights and gauges are grouped together on the instrument panel. We call this grouping a cluster. Your vehicle has a mechanical cluster.

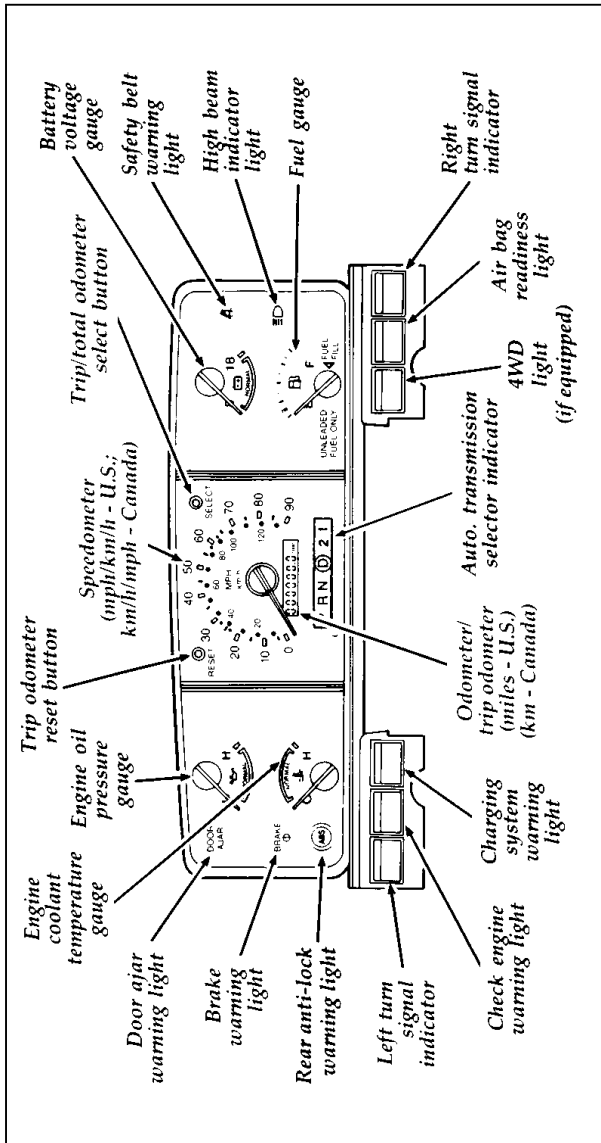

Aerostar mechanical cluster

The Mechanical Cluster

The following warning lights and gauges are on the mechanical cluster. All of the warning lights and gauges alert you to possible problems with your vehicle. Some of the lights listed are optional. The following sections detail what each of these indicators means.

Brake System Warning Light

The warning light for the brakes can show two things — that the parking brake is not fully released, or that the brake fluid level is low in the master cylinder reservoir. If the fluid level is low, the brake system should be checked by your dealer or a qualified service technician.

This light illuminates when you turn the ignition key to START to verify that the indicator bulb is working. If the light stays on or illuminates after you have released the parking brake fully, have the hydraulic brake system serviced.

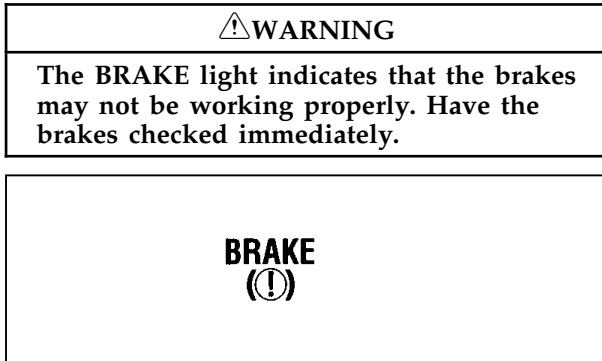

Brake warning light symbol

Rear Anti-Lock (ABS) Brake Warning Light

To check the rear ABS brake warning light, turn the ignition key to the ON position. The rear ABS brake warning light should glow momentarily.

NOTE: If it does not glow momentarily, have your vehicle's electrical system checked immediately.

NOTE: If the rear ABS brake warning light begins to flash in a repeating flash sequence, check the rear anti-lock brake system continuous power fuse and brake lights for proper operation.

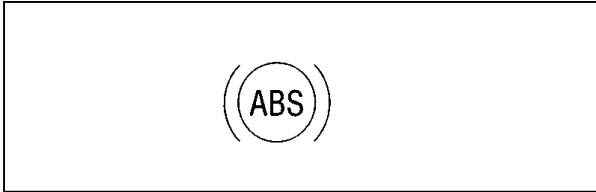

Rear anti-lock warning light symbol

| |
|---------------------------------------------------------------------------------------------------------------------------------------------------------------------------------|
|  WARNING |
| If the anti-lock brake system warning light remains on or comes on while driving, have the braking system checked by a qualified service technician as soon as possible. |

NOTE: If a fault occurs in the anti-lock system, and the brake warning light is not lit, the anti-lock system is disabled but normal brake function remains operational.

Safety Belt Warning Light and Chime

This warning light and chime remind you to fasten your safety belt. One of the following will take place:

- If the safety belt is not buckled when the key is turned to the ON position, the light comes on for 1 to 2 minutes and the chime sounds for 4 to 8 seconds.
- If the safety belt is buckled while the light is on and the chime is sounding, both the light and chime turn off.
- If the safety belt is buckled before the ignition is turned to the ON position, neither the light nor the chime will come on.

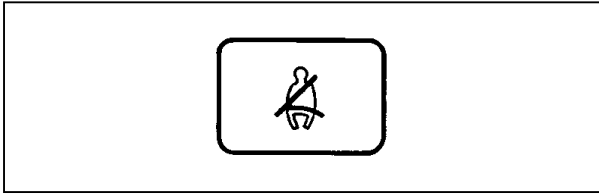

Safety belt warning light

Door Ajar Light and Chime

This light illuminates along with an audible chime if one of the doors is not completely shut when you turn the ignition to the ON position.

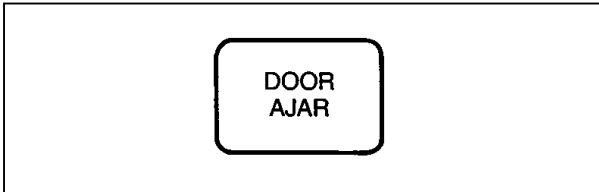

Door ajar light

Check Engine Warning Light

This light illuminates when the engine's Emission Control System requires service. It will also illuminate when the ignition key is in the ON position and the engine is off.

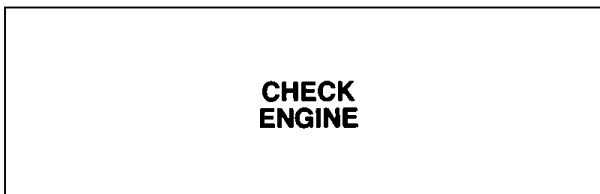

Check engine warning light

Electronic 4-Wheel Drive Warning Light (If equipped)

The Electronic 4-Wheel Drive Warning Light illuminates when the Electronic 4-Wheel Drive system is not working properly. This light illuminates briefly when you turn the ignition key to the ON position, but should turn off when the engine starts. If the light does not illuminate when you turn the ignition to the ON position, or if it illuminates and stays on when you are driving, have your vehicle serviced as soon as possible.

The 4WD light will go off after a few seconds and stay off if all systems are operating correctly. If a problem is detected, the 4WD warning light will flash a certain number of times indicating the location of the problem. The flashing will continue until the problem is corrected. Each time the ignition key is turned on, the controller will detect the problem and flash the signal. The 4WD system remains safe to operate and the vehicle should be returned for service.



Electronic 4-wheel drive warning light

Charging System Light

This light indicates that your battery is not being charged and that you need to have the electrical system checked.

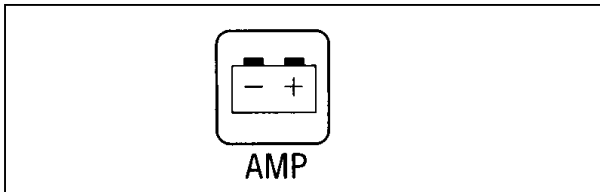

Charging system light

This light illuminates every time you turn the ignition to the ON or START position (engine off). The light should go off when the engine starts and the alternator begins to charge.

If the light stays on or illuminates when the engine is running, have the electrical system checked as soon as possible.

Supplemental Air Bag Readiness Light and Tone Generator

This light illuminates for six seconds when the ignition is turned to the ON position. If the light fails to illuminate, continues to flash, remains on, or if a series of five beeps is heard, have the system serviced as soon as possible.



Supplemental air bag readiness light

High Beam Light

This light illuminates when the headlamps are turned to high beam or when you flash the lights.

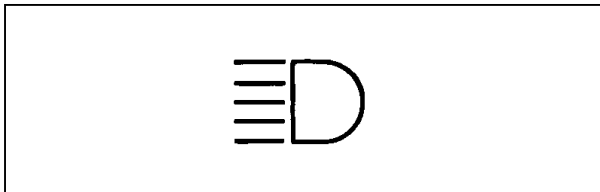

High beam indicator light

Chime for Headlamps On

This chime sounds if the driver or passenger door is open when the parking lamps or headlamps are on. The chime sounds until you close the door, turn off the lamps or turn the ignition to the ON position.

NOTE: The chime will not sound when the autolamp has activated the shutoff delay.

Ignition Key Buzzer or Chime

The buzzer or chime will sound if you open the driver's door while the key is in the ignition and in the OFF, LOCK, or ACCESSORY position. Never leave your vehicle unattended with the key in the ignition.

Battery Voltage Gauge (Voltmeter)

This gauge shows you the battery voltage when the ignition key is in the ON position.

If you are running electrical accessories (when the engine is off, or idling at a low speed), the pointer may move toward the lower end of the normal band. If it stays outside the normal band area, have your vehicle's electrical system checked as soon as it is safely possible.

If the battery is operating under cold weather conditions, the pointer may indicate in the upper range of the NORMAL band while the battery is charging. If you are running electrical accessories with the engine off or idling at a low speed, or the battery is not fully charged, the pointer may move toward the lower end of the NORMAL band.

If it stays outside the NORMAL band, have your vehicle's electrical system checked as soon as it is safely possible.

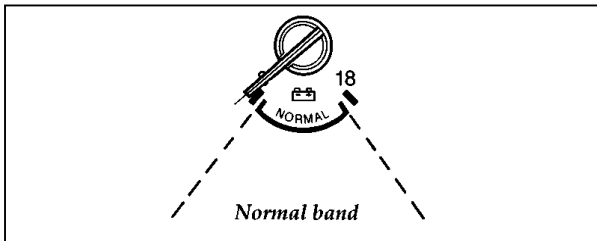

Battery voltage gauge

Engine Oil Pressure Gauge

This gauge indicates the engine's oil pressure, not the oil level. However, if your engine's oil level is low, it could affect the oil pressure. With the engine running, the pointer should move into the NORMAL band. If the pointer drops below the NORMAL band while the engine is running, you have lost oil pressure and continued operation will cause severe engine damage.

If you lose engine oil pressure:

1. Pull off the road as soon as safely possible.
2. Shut off the engine immediately or severe engine damage could result.
3. Check the engine's oil level, following the instructions on checking and adding engine oil. Refer to *Engine oil* in the Index. If you do not follow these instructions, you or others could be injured. To assure an accurate reading, your vehicle should be on level ground.
4. If the level is low, add only as much oil as necessary before you start the engine again. Do not overfill. Do not operate the engine if the pointer is below the NORMAL band, regardless of the oil level. Contact your nearest dealer for further service actions.

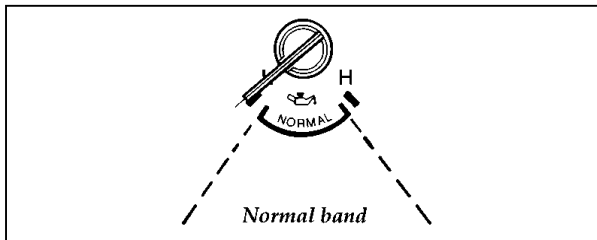

Engine oil pressure gauge

Fuel Gauge

The fuel gauge displays approximately how much fuel is in the fuel tank only when the ignition switch is ON.

For a proper fuel gauge indication after adding fuel, the ignition switch should be in the OFF position while the vehicle is being refueled.

The fuel gauge indicator may vary slightly while the vehicle is in motion. This is the result of fuel movement within the tank. An accurate reading may be obtained with the vehicle on smooth, level ground.

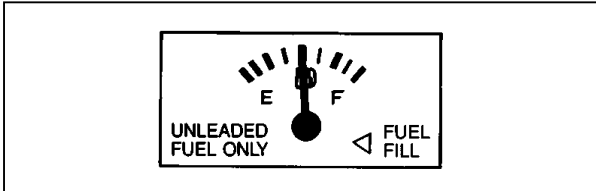

Fuel gauge

Engine Coolant Temperature Gauge

This gauge indicates the temperature of the engine coolant, not the coolant level. If the coolant is not at its proper level or mixture, the gauge indication will not be accurate.

The pointer moves from the C (cold) mark into the NORMAL band as the engine coolant warms up. It is acceptable for the pointer to fluctuate within the NORMAL band under normal driving conditions. Under certain driving conditions, such as heavy stop and go traffic or driving up hills in hot weather, the pointer may move to the top of the NORMAL band.

If, under any circumstances, the pointer moves above the NORMAL band, the engine is overheating and continued operation may cause engine damage.

If your engine overheats:

1. Pull off the road as soon as it is safely possible.
2. Turn off the engine.
3. Let the engine cool. **DO NOT REMOVE COOLANT SYSTEM FILL CAP UNTIL THE ENGINE IS COOL.**
4. Check the coolant level following the instructions on checking and adding coolant to your engine. Refer to *Engine coolant* in the Index. If you do not follow these instructions, you or others could be injured.

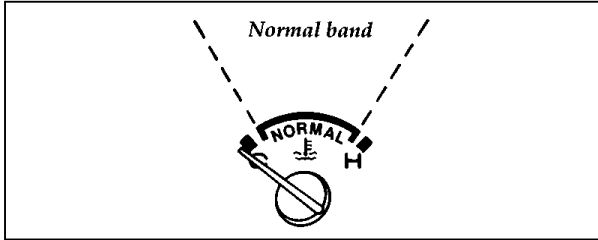

Engine coolant temperature gauge

Speedometer

The speedometer tells you how many miles (kilometers) per hour your vehicle is moving.

Your vehicle contains a speedometer which receives its input from the Anti-Lock brake sensor. The speedometer is also used to provide a speed signal for correct operation of the vehicle's Powertrain Control Module (PCM), electronic transmission, and speed control (if so equipped). Because of this, it is very **IMPORTANT** to change the speedometer's internal conversion constant if the size of the tires on the vehicle is changed. Changing the conversion constant to the proper value when

the tires are changed will also ensure that the speedometer retains the original factory-set accuracy.

NOTE: The conversion constant can only be changed six times once the vehicle leaves the factory. Your Ford dealership service personnel can change the conversion constant.

Some vehicles are equipped with a vehicle speed (mph/km/h) limiting device that is contained within the Powertrain Control Module (PCM). The purpose of this device is to maintain peak vehicle speed below a specified limit. (Vehicle speed limits may vary based on engine displacement.)

If you are experiencing an “engine cut-out” condition at high speeds, it may be the result of this limiting device. It is a normal condition and can be avoided by reducing vehicle/engine speed.

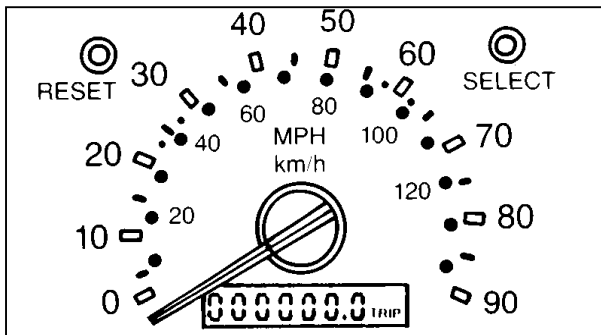

Speedometer

Odometer/Trip Odometer

The Liquid Crystal Display (LCD) odometer is a combination trip odometer and total odometer. The total odometer is normally displayed. To see the trip odometer, press and release the SELECT control on the upper right side of the speedometer. To zero out the trip odometer, press and release the RESET control on the upper left side of the speedometer while the trip odometer is displayed. If the trip odometer is displayed, press and release the SELECT control to return the display to the total odometer value.

Electronic Sound Systems

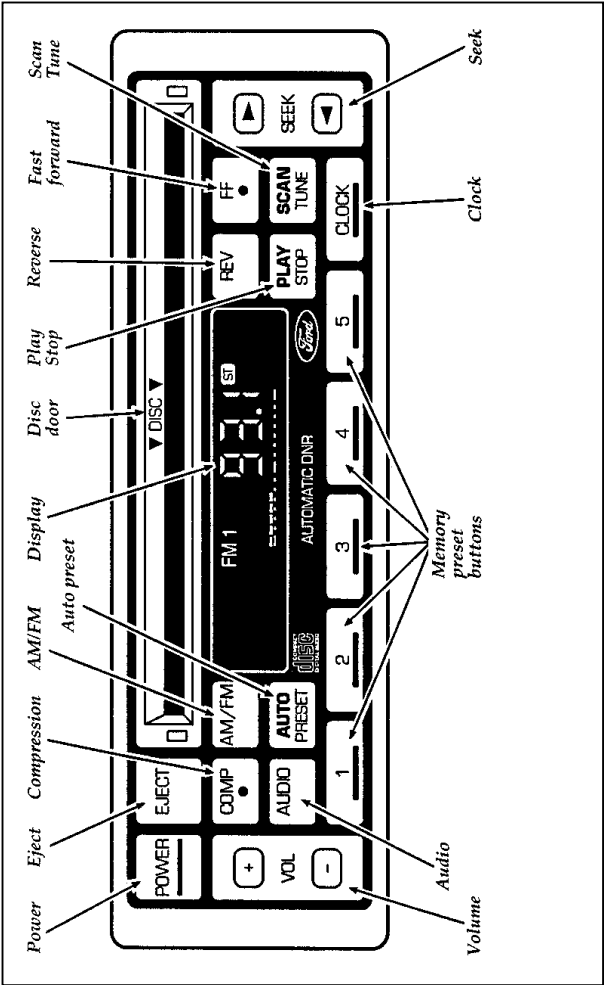

Compact Disc Radio

Compact Disc Radio

The Compact Disc Radio combines the Electronic Stereo Radio with the Ford Compact Disc Player.

Using the Controls on Your New Radio/CD Player

Most of the features of this unit work for both radio and CD operation. Also, some of the knobs and buttons control several different functions, so be sure to read all of the operating instructions carefully.

How to turn the radio on and off

Press the "POWER" button to turn the radio on. Press it again to turn it off.

How to adjust the volume

Press the (+/-) end of the "VOL" button to increase/decrease the volume. Bars illuminate in the display to show the relative volume level.

NOTE: If the volume level is set above a certain listening level when the ignition switch is turned off, when the ignition switch is turned back on, the volume will come back to a "nominal" listening level. However, if the radio power is turned off, the volume will remain in the position it was set at when radio power was switched off.

Selecting the AM or FM frequency band

Push the "AM/FM" button to select the desired frequency band. When in the radio mode, pushing the button more than once will alternate between AM, FM1 and FM2. These functions are used with the station memory buttons described under *How to tune radio stations*.

How to tune radio stations

There are four ways for you to tune in a particular station. You can manually locate the station using the “SCAN/TUNE” button, “SEEK” the station, “SCAN” to the station or select the station by using the memory buttons, which you can set to any desired frequency. These four methods are described below.

- Using the “SCAN/TUNE” button to manually tune

You can change the frequency up or down one increment at a time (FM changes in increments of 200kHz; AM changes in increments of 10kHz) by first pressing the “SCAN/TUNE” button twice (display shows “TUNE”), then — **within approximately five seconds** —pressing and releasing either the top (▶) or bottom (◀) half of the “SEEK” button. To change frequencies quickly, press and **hold down** either the top or bottom half of the “SEEK” button. While you are manually tuning, the display will show a blinking “M.”

Manual tuning adjusts your radio to any allowable broadcast frequency, whether or not a station is present on that frequency. (See *All About Radio Frequencies* in this section.)

Using the "SEEK" function

This feature on your radio allows you to automatically select listenable stations up or down the frequency band. Press the top (▶) half of the "SEEK" button to select the next listenable station up the frequency band. Press the bottom (◀) half of the button to select the next listenable station down the frequency band. By pressing and holding the button, listenable stations can be passed over to reach the desired station.

Using the "SCAN/TUNE" button to scan radio stations

Pressing the "SCAN/TUNE" button once enters the scan mode (display will indicate "SCN"). Pushing the top (▶) half of the "SEEK" button will begin the scan mode up the frequency band, stopping on each listenable station for approximately five seconds. Pushing the bottom (◀) half of the "SEEK" button will begin the scan mode down the frequency band, again stopping on each listenable station for approximately five seconds.

To stop the scan mode on the presently sampled station, press the "SCAN/TUNE" button again.

Setting the Station Memory Preset buttons

Your radio is equipped with 5 station memory buttons. These buttons can be used to select up to 5 preset AM stations and 10 FM stations (5 in FM1 and 5 in FM2). Follow the easy steps below to set these buttons to the desired frequencies.

1. Select a band, then select a frequency.
2. Press one of the memory preset buttons and hold the button until the sound returns. That station is now held in memory on that button.
3. Follow the two steps above for each station memory preset button you want to set.

NOTE: If the vehicle's battery is disconnected, the clock and station memory preset buttons (if programmed in auto mode) will need to be reset.

Using the Automatic Memory Load feature

You can activate the **Auto Memory Load** feature by pressing and holding the "AUTO PRESET" button **for approximately three seconds**. Auto Memory Load sets all memory buttons in AM, FM1 and FM2 sequentially by seeking out the first five strong stations for the respective band and storing them in memory buttons 1-5. (FM2 will store the second set of strong stations from the FM band.)

With Auto Memory Store, you can continually set strong stations into your memory buttons without losing your existing memory presets, which is especially helpful while traveling. Your radio will automatically set your memory buttons to the strong local stations so you don't have to continually manually tune to existing stations.

Activate Auto Memory Store by pushing the "AUTO PRESET" button once. Your radio will set the first five strong stations of the band you are in (AM, FM1 or FM2) into the memory buttons. The display will show "AUTO," then run through the frequencies, stopping momentarily on the stations being set into the memory buttons. The radio is now in the "AUTO" mode and the display will show "AUTO" each time a preset is activated.

NOTE: If there are fewer than five strong stations in the frequency band, the remaining unfilled buttons will store the last strong station detected on the band.

After all stations have been filled, the radio will begin playing the station stored on memory button 1.

To deactivate the Auto Memory Store mode and return to the manually-set memory button stations (or those stations set using Auto Memory Load), simply push the "AUTO PRESET" button. Display will show "AUTO" then "OFF." The next time Auto Memory Store is activated on that band, the radio will store the next set of five strong stations.

Using the "AUDIO" button to adjust the tone balance and speaker output

Increasing or decreasing bass response

Push the "AUDIO" button repeatedly until the display reads "BASS." Push the "+" side of the "VOL" button to increase bass (more "lows"), and push the "-" side to decrease bass (less "lows").

Increasing or decreasing treble response

Push the "AUDIO" button repeatedly until the display reads "TREB." Push the "+" side of the "VOL" button to increase treble (more "highs"), and push the "-" side to decrease treble (less "highs").

Adjusting speaker balance

Balance control allows you to adjust the sound distribution between the right and left speakers. Push the "AUDIO" button repeatedly until the display reads "BAL." Push the "+" side of the "VOL" button to shift the sound to the right speakers, and push the "-" side to shift the sound to the left speakers.

Adjusting speaker fader

Fade control allows you to adjust the sound distribution between the front and rear speakers. Push the "AUDIO" button repeatedly until the display reads "FADE." Push the "+" side of the "VOL" button to shift the sound to the front speakers, and push the "-" side to shift the sound to the rear speakers.

NOTE: Illuminated bars in the display show relative levels of bass and treble and positions of speaker balance and fader functions after adjustments are made, then revert to volume level set.

Clock operation

When in the radio mode, push the "CLOCK" button to switch from radio frequency to clock. Only the clock numerals will be displayed in the clock mode — there is no AM/PM indication. When in the clock mode, the time will be displayed until the button is pushed again. However, if you retune the radio while it is in the clock mode, the new radio frequency will be displayed for approximately ten seconds and then change back to clock display.

When in the CD mode, push the "CLOCK" button to change the display from elapsed time mode to track number mode to clock mode. If the CD track selection is changed when you are in the clock or elapsed time mode, the new track number will be displayed for approximately ten seconds and then revert back to the previous mode.

The clock can also be viewed with the ignition off. Push the "CLOCK" button and the time will be displayed momentarily.

To set the clock, simultaneously press the "CLOCK" button and either the bottom (◀) half of the "SEEK" button to set hours, or the top (▶) half of the "SEEK" button to set minutes.

Using the Controls on Your New Compact Disc Player

Your new Ford Compact Disc Player is capable of playing 12 cm *or* 8 cm discs, without an adapter. The player operates when the power is on and a disc is inserted (**label side up**). Handle the disc by its edge only. (Be sure to read and follow all of the care and cleaning instructions under *How To Take Care of and Clean Your CD Player and Discs*.)

NOTE: If after you insert a disc, the disc is ejected and "ERROR" begins scrolling in the display, remove the disc and reinsert it right side up (label side up).

The digital display on your CD player will either show the track (selection) number or the elapsed time. (The display mode can be selected by pressing the "CLOCK" button.) Indicators for play (▶), stop (■) and compression on ("C") are also in the display. (These features are described later.)

Once a disc is inserted, operation of the CD player will override that of the radio.

NOTE: The volume, bass, treble, balance and fader controls on the radio are also used with the CD player. Refer to earlier operating instructions about these controls.

How to insert a disc and begin play

Insert one disc, **label side up** into the disc opening. When inserted, the disc automatically loads into the unit and play starts at the beginning of the first track (selection).

When the disc reaches the end, the disc player automatically returns to the beginning of the disc and resumes playing.

NOTE: Once a disc is inserted, the disc opening is secured to prevent the accidental insertion of a second disc.

NOTE: The CD player has heat protection circuitry to protect the laser diode. If the temperature of the player reaches 167°F (75°C), the heat detection circuit will shut off the player and "TOO HOT" will scroll in the display for approximately five seconds (radio will resume playing). When the temperature returns to normal operating range, the CD player will again be operational.

How to stop and restart the CD player

When a disc is loaded, the unit automatically enters the play mode and the play indicator (▶) illuminates. To stop temporarily, press the "PLAY/STOP" button or the "AM/FM" button. The stop indicator (■) in the display illuminates and operation returns to the radio mode. To resume CD play, press the "PLAY/STOP" button once again.

NOTE: If the ignition key is turned OFF during play and then is set to the ON or ACCESSORY position, the CD player will resume playing in the mode it was in when ignition was turned off.

Using the "SEEK" feature

The "SEEK" feature allows you to quickly find a particular selection on the disc.

Press the bottom (◀) half of the "SEEK" button once to repeat the current playing selection. Press the top (▶) half of the "SEEK" button to advance to the next selection.

Pressing and holding the bottom (◀) or top (▶) half of the "SEEK" button will scroll backward and forward respectively through the tracks.

How to fast forward or reverse your CD player

To quickly search for a particular point in a selection, press the "FF" button (to fast forward) or the "REV" button (to reverse). While either button is pressed, the disc goes forward or backward at two different speeds depending on how long the button is held down. (Pressing either button for more than three seconds will speed up the process.) Release the button at the desired point (found by watching the elapsed playing time in the display or by listening to the sound during fast forward or reverse). When you have reached the beginning of track 1, the CD player will begin playing.

When you have reached the end of the disc by keeping the fast forward button pressed, the display will show "END" and the player will go into pause mode. Push the "PLAY/STOP" button to begin playing the first track of the disc, press the "REV" button to back up from the end of the disc, or use the "SEEK" function to locate a desired track.

Using the "SCAN" function

Press the "SCAN/TUNE" button to enter the scan mode. Once in the scan mode, press the top (▶) or bottom (◀) half of the "SEEK" button to scan forward or reverse, respectively. The CD player will begin scanning the disc, stopping on each listenable track for approximately eight seconds. This continues until you press the "SCAN/TUNE" button a second time. While in the scan mode, the display shows the current sampled track number.

Special features of your CD player

Compression

The compression feature will bring soft and loud passages closer together for a more consistent listening level.

To turn the compression on, press the "COMP" button. When on, the compression indicator ("C") will appear in the display. Press the button again to turn off.

Automatic Disc Storage

If the disc is ejected from the CD player but is not removed from the disc opening within approximately 10 seconds, the player will automatically reload the disc for storage, unless the disc is automatically ejected due to a "focus error" (disc inserted upside down). In this case, the disc will not be automatically reloaded.

How to eject the disc

Push the "EJECT" button to stop play, eject the disc and resume radio operation of your audio system.

NOTE: You can eject the disc while the radio power and/or ignition is on or off.

How To Take Care of and Clean Your CD Player and Discs

To ensure the continued performance of your Ford Compact Disc Player, carefully read the following precautions:

- Always handle the disc by its edge. Never touch the playing surface.

- Before playing, inspect the disc for any contamination. If needed, clean the disc with an approved disc cleaner, such as the Discwasher® Compact Disc Cleaner or the Allsop 3® Compact Disc Cleaner, by wiping from the center out to the edges. **Do not use a circular motion to clean.**
- Do not clean discs with solvents such as benzine, thinner, commercially available cleaners or antistatic spray intended for analog records.
- Do not expose the disc to direct sunlight or heat sources such as defroster and floor heating ducts. Do not leave any discs in a parked car in direct sunlight where there may be a considerable rise in temperature or damage may result.
- After playing, store the disc in its case.
- If a disc has already been inserted, do not try to insert another disc. Doing so may damage the disc player.
- Do not insert anything other than a disc into the disc player.

NOTE: The use of optical instruments with this product will increase eye hazard as the laser beam used in this compact disc player is harmful to the eyes. Do not attempt to disassemble the case. Refer servicing to qualified personnel only.

Common Operating Conditions of Your CD Player

The following information is designed to help you recognize typical situations that could be mistakenly interpreted as mechanical malfunctions of the disc player.

- A disc is already loaded.
- The disc is inserted with the label surface downward.
- The disc is dusty or defective.
- The player's internal temperature is above 140°F (60°C). Allow the player to cool off before operating.
- Different manufacturers of compact discs may produce discs with different dimensions or tolerances, some of which may not be within industry standards or in accordance with the CD format. Because of this, a new disc that is free of dust and scratches could be defective and may not play on your Ford Compact Disc Player.

If play does not begin once the disc has been inserted:

- The radio is not on.
- The unit is in the stop mode.
- Moisture may have condensed on the lenses within the unit. If this occurs, remove the disc and wait approximately an hour until the moisture evaporates.

If the sound skips:

- Badly scratched discs or extremely rough roads will cause the sound to skip. Skipping will not damage the disc player or scratch the discs.

High-Level Audio System

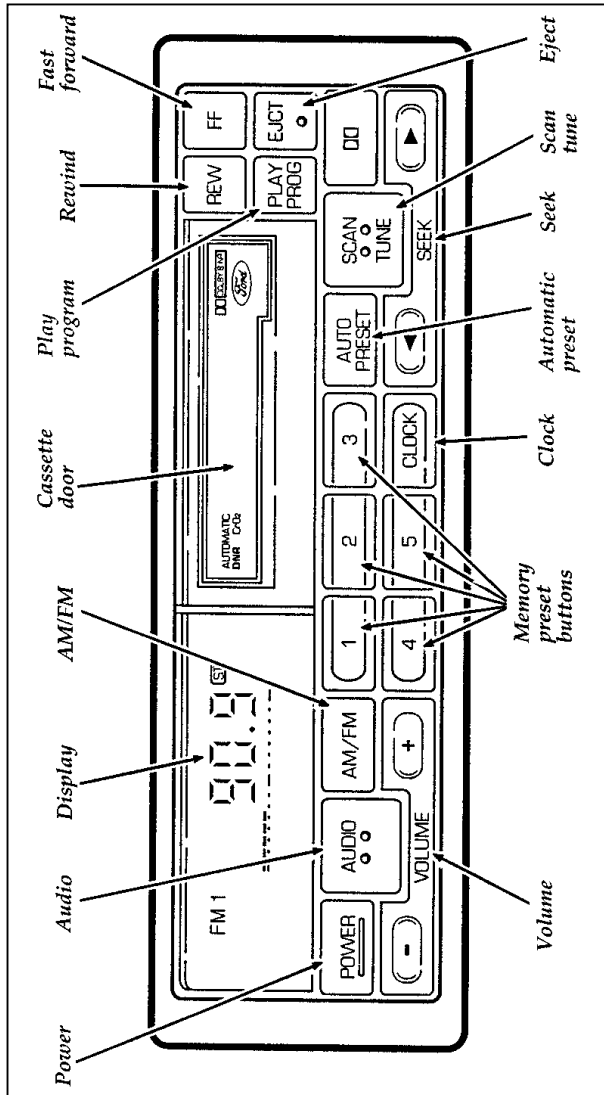

High-Level Audio System

Using the Controls on Your New Radio

How to turn the radio on and off

Press the "POWER" button to turn the radio on. Press it again to turn it off.

How to adjust the volume

Press the (+/-) side of the "VOL" button to increase/decrease the volume. Bars illuminate in the display to show the relative volume level.

NOTE: If the volume level is set above a certain listening level when the ignition switch is turned off, when the ignition switch is turned back on, the volume will come back to a "nominal" listening level. However, if the radio power is turned off, the volume will remain in the position it was set at when radio power was switched off.



Selecting the AM or FM frequency band

Push the "AM/FM" button to select the desired frequency band. When in the radio mode, pushing the button more than once will alternate between AM, FM1 and FM2. These functions are used with the station memory buttons described under *How to Tune Radio Stations*.

How to tune radio stations



There are four ways for you to tune in a particular station. You can manually locate the station using the “SCAN/TUNE” button, “SEEK” the station, “SCAN” to the station or select the station by using the memory buttons, which you can set to any desired frequency. These four methods are described below.

Using the “TUNE” function (Stereo Radio)

You can change the frequency up or down one increment at a time (FM changes in increments of 200 kHz; AM changes in increments of 10 kHz) by first pressing the “SCAN/TUNE” button twice (display shows “TUNE”), then — **within approximately five seconds** —pressing and releasing either the right  or left  side of the “SEEK” button. To change frequencies quickly, press and **hold down** either the right or left side of the “SEEK” button.

Manual tuning adjusts your radio to any allowable broadcast frequency, whether or not a station is present on that frequency. (See *All About Radio Frequencies* in this section.)

Using the “SEEK” function

This feature on your radio allows you to automatically select listenable stations up or down the frequency band. Press the right  side of the “SEEK” button to select the next listenable station up the frequency band. Press the left  side of the button to select the next listenable station down the frequency band. By holding the button down, listenable stations can be passed over to reach the desired station.

Using the "SCAN" function

Pressing the "SCAN/TUNE" button once enters the scan mode (display will indicate "SCN"). Pushing the right (▶) side of the "SEEK" button will begin the scan mode up the frequency band, stopping on each listenable station for approximately a five-second sampling. Pushing the left (◀) side of the "SEEK" button will begin the scan mode down the frequency band, again stopping on each listenable station for approximately a five-second sampling.

To stop the scan mode on the presently sampled station, press the "SCAN/TUNE" button again.

Setting the Station Memory Preset buttons

Your radio is equipped with 5 station memory buttons. These buttons can be used to select up to 5 preset AM stations and 10 FM stations (5 in FM1 and 5 in FM2).

Follow the easy steps below to set these buttons to the desired frequencies:

1. Select a band, then select a frequency.
2. Press one of the memory buttons and hold the button until the sound returns. That station is now held in memory on that button.
3. Follow the two steps above for each station memory preset button you want to set.

NOTE: If the vehicle's battery is disconnected, the station memory preset buttons (if programmed in auto mode) will need to be reset.

□ Using the Automatic Memory Load feature

You can activate the **Auto Memory Load** feature by pressing and holding the “AUTO PRESET” button **for approximately three seconds**. Auto Memory Load sets all memory buttons in AM, FM1 and FM2 sequentially by seeking out the first five strong stations for the respective band and storing them in memory buttons 1-5. (FM2 will store the second set of strong stations from the FM band.)

With Auto Memory Store, you can continually set strong stations into your memory buttons without losing your existing memory presets, which is especially helpful while traveling. Your radio will automatically set your memory buttons to the strong local stations so you don't have to continually manually tune to existing stations.

Activate Auto Memory Store by pushing the “AUTO PRESET” button once. Your radio will set the first five strong stations of the band you are in (AM, FM1 or FM2) into the memory buttons. The display will show “AUTO,” then run through the frequencies, stopping momentarily on the stations being set into the memory buttons. The radio is now in the “AUTO” mode and the display will show “AUTO” each time a preset is activated.

NOTE: If there are fewer than five strong stations in the frequency band, the remaining unfilled buttons will store the last strong station detected on the band.

After all stations have been filled, the radio will begin playing the station stored on memory button 1.

To deactivate the Auto Memory Store mode and return to the manually-set memory button stations (or those stations set using Auto Memory Load), simply push the "AUTO PRESET" button. Display will show "AUTO" then "OFF." The next time Auto Memory Store is activated on that band, the radio will store the next set of five strong stations.

Adjusting the tone balance and speaker output of your radio

Increasing or decreasing bass response

Push the "AUDIO" button repeatedly until the display reads "BASS." Push the "+" side of the "VOL" button to increase bass (more "lows"), and push the "-" side to decrease bass (less "lows").

Increasing or decreasing treble response

Push the "AUDIO" button repeatedly until the display reads "TREB." Push the "+" side of the "VOL" button to increase treble (more "highs"), and push the "-" side to decrease treble (less "highs").

Adjusting speaker balance

Balance control allows you to adjust the sound distribution between the right and left speakers. Push the "AUDIO" button repeatedly until the display reads "BAL." Push the "+" side of the "VOL" button to shift the sound to the right speakers, and push the "-" side to shift the sound to the left speakers.

□ Adjusting speaker fader

Fade control allows you to adjust the sound distribution between the front and rear speakers. Push the "AUDIO" button repeatedly until the display reads "FADE." Push the "+" side of the "VOL" button to shift the sound to the front speakers, and push the "-" side to shift the sound to the rear speakers.

NOTE: Illuminated bars in the display show relative levels of bass and treble and positions of speaker balance and fader functions after adjustments are made, then revert to volume level set.

Using the Controls of Your Cassette Tape Player (If equipped)

How to insert a tape

Your cassette tape player is equipped with power loading. Once you insert a tape and push slightly (with the **open edge to the right**), the loading mechanism draws the tape the rest of the way in and play will begin after a momentary tape tightening process. Display indicates "M" (for metal/CrO₂) while tape is playing.

NOTE: A cassette tape can be loaded with the ignition on whether or not the radio power is on.

How to locate a desired track on the tape

There are four ways to quickly locate a desired selection on the tape. You can use the fast forward, rewind, "SEEK" or "SCAN" function. Following are brief descriptions of each.

Fast forwarding the tape

To fast forward the tape, press the "FF" button. The radio will automatically begin playing until fast forward is manually stopped. At the end of the tape, the direction automatically reverses and plays the other side of the tape.

Rewinding the tape

To rewind the tape, press the "REW" button.

The radio will automatically begin playing until rewind is manually stopped or the beginning of the tape is reached.

Using the "SEEK" function with your cassette tape player

While in the tape mode, push the right ► side of the "SEEK" button to seek forward to the next selection on the tape. Push the left ◀ side to seek the previous tape selection.



NOTE: If you want to restart a currently playing tape selection, press the left ◀ side of the "SEEK" button after approximately three seconds into the current selection.

Whirling sprockets in the display  indicate the direction of tape travel.

- Using the "SCAN" function with your cassette tape player

Press the "SCAN/TUNE" button to enter the scan mode (display indicates "SCN").

Pushing the right  side of the "SEEK" button will begin the forward scan mode on the tape currently playing, stopping on each tape selection for approximately an eight-second sampling.

Pushing the left  side of the "SEEK" button will begin the reverse scan mode, stopping on each previous tape selection for approximately an eight-second sampling. While scanning, the display indicates whirling sprockets plus an "S" .

To stop the scan mode on the presently sampled tape selection, press the "SCAN/TUNE" button again.

- How to change the side of the tape being played

The alternate track of the tape can be selected anytime by pressing the "PLAY/PROG" button.

How to eject the tape



To stop the tape and eject the cassette, press the "EJCT" button. The radio will resume playing if the radio power is on. The tape cartridge can be ejected with radio power (and/or ignition) on or off.

How to store the tape

Press the "AM/FM" button to stop the tape player and resume radio play. The cassette will be stored in the tape player and the  symbol in the display will be lit until you push the "PLAY PROG" button to resume tape play. Fast forward and fast rewind can be used while the tape is in storage mode without interrupting radio play.

Using the Dolby® B noise reduction feature

NOTE: Noise reduction system manufactured under license from Dolby Labs Licensing Corporation. "Dolby" and double-D symbol are trademarks of Dolby Laboratories Licensing Corporation.

Push the  button to activate. When on, the  symbol above the button will be lit.

Clock Operation

How to view the clock mode

Press the "CLOCK" button to alternate the frequency and time in the display. In the clock mode, pressing any radio function will automatically display the radio frequency for approximately ten seconds before changing back to the clock mode.

How to set the clock

1. Turn the radio on.
2. Press and hold in the "CLOCK" button. Press the "SEEK" button left (◀) to advance the hours and right (▶) to advance the minutes.

NOTE: The clock displays 12-hour time with no AM/PM indications.

NOTE: On the High-Level Audio System, the clock can be set with the radio power on or off.

Tape error messages

Your cassette tape player is equipped to diagnose certain problems you may experience. Error codes are as follows:

Error 0 — Communication error between the radio controller and the tape controller. The cassette player will eject the tape. Insert the tape again. If the same error code appears, turn the ignition off, then back on again and insert the tape.

Error 1 — Possible problem cartridge. The cassette tape player will eject the tape. Insert the tape again. If the same error code appears in the display, try a different cartridge.

Error 2 — Tape eject or load failure. Your cassette tape player will go into the pause mode. Push "EJECT" to eject the tape. If the tape doesn't eject, refer the problem to qualified personnel for service.

Tips on Caring for the Cassette Player and Tapes

In order to keep your cassette tape player performing the way it was meant to, read and follow these simple precautions:

- Using a Ford or equivalent cassette cleaning cartridge to clean the tape player head after 10-12 hours of play will help maintain the best playback sound and proper tape operation.
- Only cassettes that are 90 minutes long or less should be used. Tapes longer than 90 minutes are thinner and subject to breakage or may jam the tape player mechanism.

- Protect cassettes from exposure to direct sunlight, high humidity and extreme heat or cold. If they are exposed to extreme conditions, allow them to reach a moderate temperature before playing.
- If a tape is loose inside the cassette, tighten it before playing by putting your finger or a pencil into one of the holes and turning the hub until the tape is tight.
- Loose labels on cassette tapes can become lodged in the mechanism. Remove any loose label material before inserting cassette.
- Do not leave a tape in the cassette tape player. High heat in the vehicle can cause the cassette to warp.

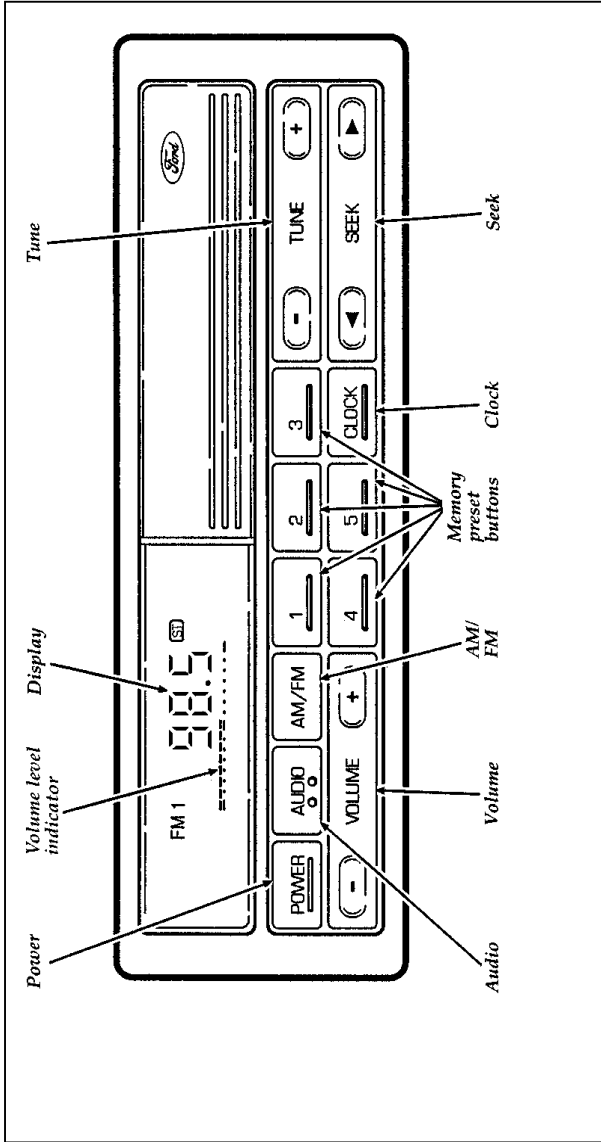

Electronic Stereo Radio

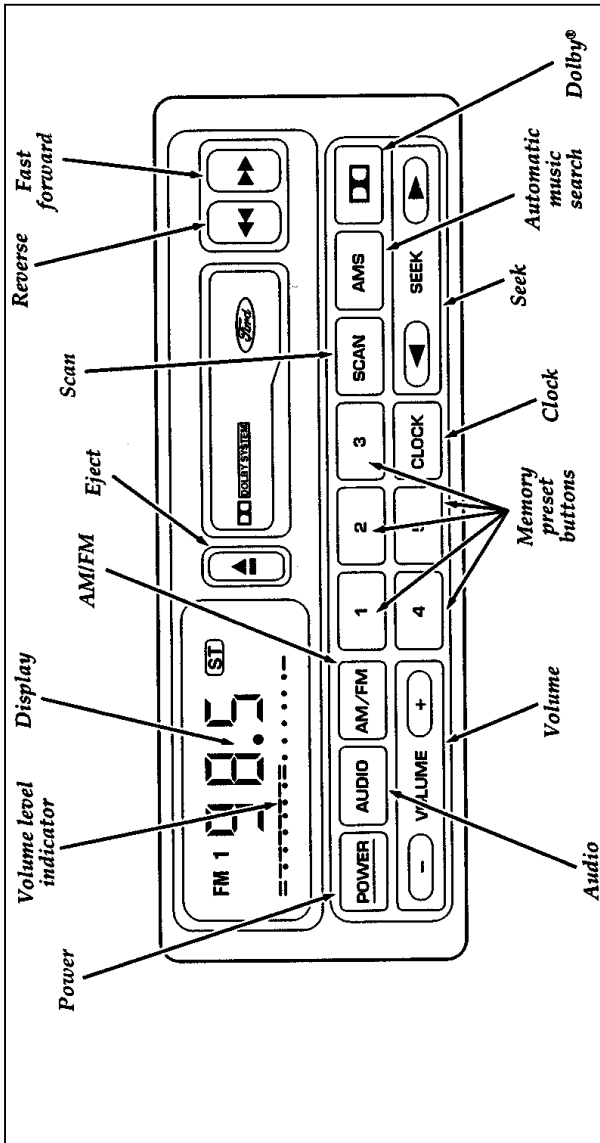

Electronic Stereo Radio with Cassette

Electronic Stereo and Stereo Cassette Radios

Using the Controls on Your New Radio

How to tune radio stations (Stereo Radio)

There are three ways for you to tune in to a particular station. You can manually locate the station by using the "TUNE" button, "SEEK" the station or select the station by using the memory preset buttons, which you can set to any desired frequency.

How to tune radio stations (Stereo Cassette Radio)

There are five ways for you to tune in to a particular station. You can manually locate the station by using the "Tune" button, Automatic Music Search ("AMS"), "SEEK" the station, "SCAN" to the station or select the station by using the memory preset buttons, which you can set to any desired frequency.

Using the "TUNE" function (Stereo Radio)

You can change the frequency up or down one increment at a time by pressing and releasing either the right (+) or left (-) side of the "TUNE" button. To change frequencies quickly, press and hold down either the right or left side of the "TUNE" button.

Manual tuning adjusts your radio to any allowable broadcast frequency, whether or not a station is present on that frequency. (See *All About Radio Frequencies* in this section.)

- Using the "AMS" function to manually tune your radio (Stereo Cassette Radio)

You can change the frequency up or down one increment at a time by first pressing the "AMS" button (display shows "TUNE") then within approximately five seconds pressing and releasing either the right (▶) or left (◀) side of the "SEEK" button. To change frequencies quickly, press and **hold down** either the right or left side of the "SEEK" button.

- Using the "SEEK" function

Press the right (▶) side of the "SEEK" button to select the next listenable station up the frequency band. Press the left (◀) side of the button to select the next listenable station down the frequency band. By holding the button down, listenable stations can be passed over to reach the desired station.

- Using the "SCAN" function (Stereo Cassette Radio)

Press the "SCAN" button to enter the scan mode. The radio will begin scanning up the frequency band, stopping on each listenable station for approximately a five-second sampling. This continues until you press the "SCAN" button a second time.

- Setting the Station Memory Preset buttons

Your radio is equipped with 5 station memory buttons. These buttons can be used to select up to 5 preset AM stations and 10 FM stations (5 in FM1 and 5 in FM2). Follow the easy steps below to set these buttons to the desired frequencies.

1. Select a band, then select a frequency.
2. Press one of the memory preset buttons and hold the button until the sound returns. That station is now held in memory on that button.
3. Follow the two steps above for each station memory preset button you want to set.

NOTE: If the vehicle's battery is disconnected, the clock and station memory preset buttons (if programmed in auto mode) will need to be reset.

Using the Controls of Your Cassette Tape Player (If equipped)

How to insert a tape

Insert a cassette (with the open edge to the right) firmly into the tape door opening, making sure the cassette is completely in and "seated."

NOTE: A cassette tape can be loaded with the ignition on whether or not the radio power is on.

How to locate a desired track on the tape

Using the Automatic Music Search ("AMS")

Press and hold the "AMS" button ("AMS" will appear in the display). Then, push the left (◀◀) button to rewind to the beginning of the current selection or press the right (▶▶) button to fast forward to the beginning of the next selection.

How to change the side of the tape being played

The alternate track (other side) of the tape can be selected at any time by pushing both fast-wind buttons (◀◀ and ▶▶) at the same time.

How to eject the tape

To stop the tape and eject the cassette, press the “▲” button. The radio will resume playing.

Using the Dolby® B noise reduction feature

Push the  button to activate. Push again to deactivate.

NOTE: Noise reduction system manufactured under license from Dolby Labs Licensing Corporation. “Dolby” and double-D symbol are trademarks of Dolby Laboratories Licensing Corporation.

How to view the clock mode

Press the “CLOCK” button to alternate the frequency and time in the display. In the clock mode, pressing any radio function will automatically display the radio frequency for approximately ten seconds before changing back to the clock mode.

How to set the clock

1. Turn the radio on.
2. Press and hold in the “CLOCK” button. Press the “SEEK” button left (◀) to advance the hours and right (▶) to advance the minutes.

NOTE: The clock displays 12-hour time with no AM/PM indications.

Tips on Caring for the Cassette Player and Tapes

In order to keep your cassette tape player performing the way it was meant to, read and follow these simple precautions:

- Using a Ford or equivalent cassette cleaning cartridge to clean the tape player head after 10-12 hours of play will help maintain the best playback sound and proper tape operation.
- Only cassettes that are 90 minutes long or less should be used. Tapes longer than 90 minutes are thinner and subject to breakage or may jam the tape player mechanism.
- Protect cassettes from exposure to direct sunlight, high humidity and extreme heat or cold. If they are exposed to extreme conditions, allow them to reach a moderate temperature before playing.
- If a tape is loose inside the cassette, tighten it before playing by putting your finger or a pencil into one of the holes and turning the hub until the tape is tight.
- Loose labels on cassette tapes can become lodged in the mechanism. Remove any loose label material before inserting a cassette.
- Do not leave a tape in the cassette tape player when not in use. High heat in the vehicle can cause the cassette to warp.

Rear Seat Radio Controls

Using the Rear Seat Radio Controls

Rear seat radio controls are available on some Aerostar models.

The rear seat radio controls are located behind the driver on the left hand side of the vehicle. These controls duplicate several radio functions of the radio and allow the use of headphones in the vehicle.

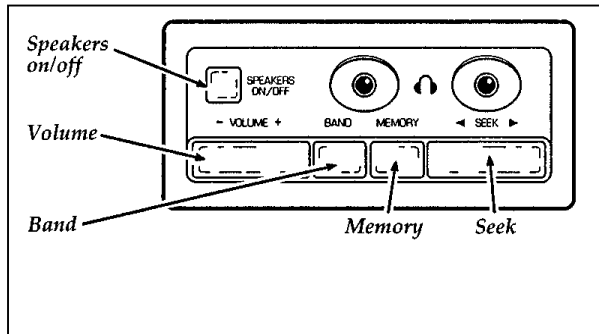

Rear seat radio controls

How to turn the rear seat radio controls on and off

Press memory preset buttons "1" and "3" simultaneously on the face of your radio to turn the rear seat radio controls on. A headphones symbol (🎧) will appear in the display when the rear seat controls are on. Press "1" and "3" simultaneously again to turn the rear seat radio controls off.

How to adjust the volume

Press the right (+) side of the "VOLUME" rocker switch to increase volume; and push the left (-) side to decrease the volume of the rear speakers.

NOTE: Rear seat control volume can be set no higher than current radio setting unless speakers are turned off. See note under *How to turn the speakers on and off.*

Setting the AM or FM frequency band

Push the "BAND" button to change the frequency band.

Using the "MEMORY" button

Push the "MEMORY" button to access the station you have set into memory button 1 on the face of the radio. Successively pushing this button will access, numerically, all stations set into the Station Memory Preset buttons (1 through 5).

How to turn the speakers on and off

When the rear seat controls are on, push the "SPKRS ON-OFF" button to turn all speakers off. Push again to turn all speakers on.

NOTE: Turning the ignition off then on again will not turn the speakers back on, if previously turned off by the "SPKRS ON-OFF" button on the rear seat controls.

Using the "SEEK" function

Press the right (▶) side of the "SEEK" rocker switch to seek to the next radio station. Press the left (◀) side of the "SEEK" rocker switch to seek to the previous radio station.

NOTE: When using the rear seat controls with a High-Level Audio System, the "SEEK" function on the rear seat controls will also function with cassettes, seeking the next ("SEEK ▶") or previous ("◀ SEEK") selection on the tape.

Using headphones with the rear seat controls

Two 3.5 mm headphone jacks have been provided on the rear seat controls. Plug headphone(s) into the provided jack(s) to operate.

Common Radio Reception Conditions

Several conditions prevent FM reception from being completely clear and noise-free, such as the following:

1. Distance/Strength

The strength of the FM signal is directly related to the distance the signal must travel. The listenable range of an average FM signal is approximately 25 miles (40 kilometers). Beyond this distance, the radio is operating in a fringe area and the signal becomes weaker.

NOTE: Always make sure your antenna (whether you have a power antenna or a manually adjustable antenna) is fully extended to its maximum length for proper reception. If your antenna is not fully extended, you may experience signal loss while traveling in fringe reception areas.

2. Terrain

The terrain (hilly, mountainous, tall buildings) of the area over which the signal travels may prevent the FM signal from being noise-free.

If there is a building or large structure between the antenna and station, some of the signal “bends” around the building, but certain spots receive almost no signal. Moving out of the

“shadow” of the structure will allow the station to return to normal.

When the radio waves are reflected off objects or structures, the reflected signal cancels the normal signal, causing the antenna to pick up noise and distortion. Cancellation effects are most prominent in metropolitan areas, but also can become quite severe in hilly terrain and depressed roadways.

To minimize these conditions, a stereo/mono blend circuit has been incorporated into this system. This feature automatically switches a weak stereo signal to a clearer monaural signal, which improves the quality of reception.

Several sources of static are normal conditions on AM frequencies. These can be caused by power lines, electric fences, traffic lights and thunderstorms.

Another reception phenomenon is **Strong Signal Capture and Overload**. This can occur when listening to a weak station and when passing another broadcast tower. The close station may capture the more distant station, although the displayed frequency does not change. While passing the tower, the station may switch back and forth a few times before returning to the original station.

When several broadcast towers are present (common in metropolitan areas), several stations may overload the receiver, resulting in considerable station changing, mixing and distortion.

Automatic gain control circuitry for both AM and FM bands has been incorporated into this system to reduce strong signal capture and overload.

All About Radio Frequencies

The Federal Communications Commission (FCC) and the Canadian Radio Telecommunications Commission (CRTC) establish the frequencies that AM and FM radio stations may use for their broadcasts. The allowable frequencies are, AM: 530, 540...1600, 1610 kHz in 10 kHz steps; FM: 87.9, 88.1...107.7, 107.9 MHz in 0.2 MHz steps.

Not all frequencies will be assigned to a given area. This radio will tune to each of these frequencies using manual tune and no fine tuning is necessary as radio stations may not use other frequencies.

Some FM radio stations advertise a "rounded-off" frequency which is not the frequency they actually broadcast on. For example, a radio station that is assigned a frequency of 98.7 MHz may call itself "Radio 99" even though 99.0 MHz is not an allowable FM broadcast frequency.

Important Warranty and Service Information

Warranty

Your sound system is warranted for three years or 36,000 miles (60,000 kilometers), whichever comes first. Consult your vehicle warranty booklet for further information. Ask your dealer for a copy of this limited warranty.

Service

At Ford, we stand behind our audio systems with a comprehensive service and repair program. If anything should go wrong with your Ford audio system, return to your dealer for service. There is a nationwide network of qualified Ford authorized repair centers to assist you.

Controls and Features

The main controls for the climate control system, clock, and radio are on the instrument panel.

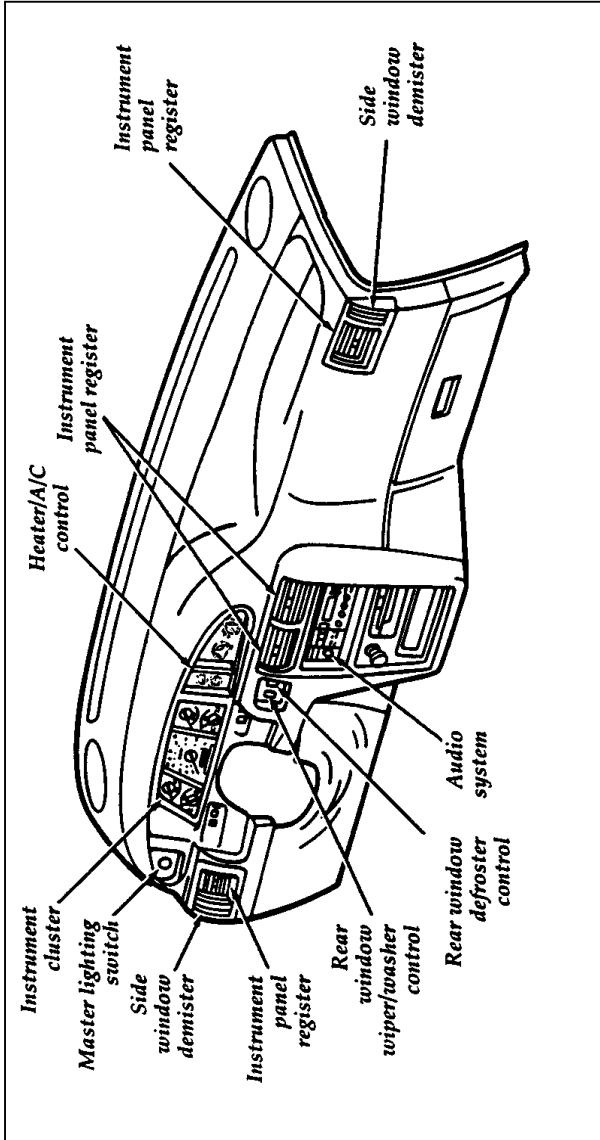

Instrument panel and controls

NOTE: Any cleaner or polish that increases the gloss (shine) of the upper part of the instrument panel should be avoided. The dull finish in this area is to help protect the driver from undesirable windshield reflection.

The Climate Control Systems

Your vehicle is equipped with a control assembly designed to handle either a combination A/C-Heater System or a Heater-Only System.

If your vehicle has a factory installed auxiliary system, the front control will be equipped with a rear fan control switch. If it is a factory installed auxiliary system with rear A/C and/or rear heater functions, an auxiliary fan speed control switch is installed in the rear of the vehicle.

Instrument Panel Registers

There are four registers in the instrument panel. Each of these registers contains a louver assembly which can be manually adjusted to direct airflow up, down, left and right. An illustration of the register locations follows.

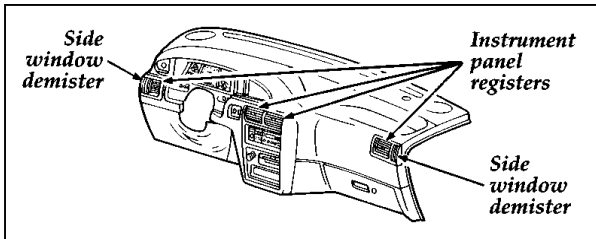

Instrument panel registers

Air Conditioner and Heater (If equipped)

The control for your air conditioner and heater system is located near the center of the instrument panel and operates only when the ignition key is turned to the ON position. Your air conditioner and heater heats or cools your vehicle interior depending on the function and the temperature you select. The right knob is the SELECT knob which allows you to select heating or cooling and determine where the air will be directed. The TEMP knob setting determines the temperature of the air that flows into the vehicle.

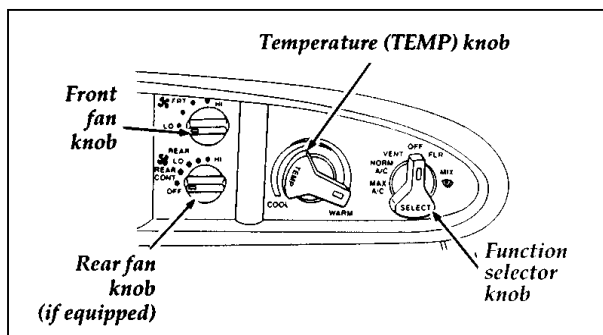



Climate control knobs

To turn your air conditioner and heater system on, rotate the SELECT knob to any position except OFF. This will turn the fan on and allows airflow into the vehicle.

Temperature selection

The TEMP knob is the rotating knob located at the center of the control with tapered red and blue bands surrounding most of the knob. The wide red part of the band (full right) is the heat area. The wide blue area (full left) is the cooling temperature area. Any position selected between full right and full left will give a temperature between the two extremes except in MAX A/C.

Fan speed adjustment

The left knob or upper left knob with the  is the fan speed knob. Rotate the  knob to the right to increase fan speed and increase the amount of air entering the vehicle. Four fan speed positions are available.

Function selection



Use VENT to bring outside air through the instrument panel registers. You can heat the air in this position by rotating the center knob into the red area. The air cannot be cooled below the outside temperature regardless of the TEMP knob setting.

Select NORM A/C to get refrigerated outside air through the instrument panel registers. The NORM A/C position is used for cooling except when it is extremely hot or fast cooling of the vehicle is needed. Select MAX A/C for fast cooling and return to NORM A/C when you are comfortable.

The MAX A/C position rapidly produces cool air to provide faster cooling of your vehicle. This is possible because cooler air is drawn from inside the passenger area and cooled again instead of using warmer outside air. Use of inside air makes the fan sound louder and is normal when using MAX A/C. You cannot adjust the air temperature when operating in MAX A/C. If the airflow is too cold, select NORM A/C and adjust the air temperature as desired.

Airflow will be to the floor when FLR is selected. The air cannot be cooled in the FLR position but can be heated by rotating the TEMP knob into the red area.

Select MIX to direct air to the floor and windshield defrosters at the same time. If the outside temperature is about 50°F (9°C) or warmer, the air will also be dehumidified to remove moisture. This feature will help prevent fogging in humid weather. The air can be cooled or heated.

Select  to obtain maximum airflow to the windshield. Rotate the TEMP knob into the red area for the air temperature required to defrost. When the outside temperature is about 50°F (9°C) or warmer, the air will be dehumidified to remove moisture. Rotate the  knob on the left to increase the airflow.

Operating Tips

The following tips help you get the most satisfaction from your air conditioner and heater system:

- In humid weather, select  before starting your engine. This helps prevent windshield fogging. After a few minutes of operation, you may select another airflow position.
- To prevent humidity buildup inside your vehicle, always drive with the air conditioner and heater system turned on.
- Do not put objects under the front seats that interfere with the flow of air to the back seat area.
- Remove any snow, ice, or leaves from the air intake area at the bottom of the windshield.
- For maximum heating, rotate the function selector knob to FLR, the temperature control knob to the red (warm) range, and the fan knob to HI.

Standard Heater

The control for your heater system is located near the center of the instrument panel and operates only when the ignition key is turned to the ON position. The heater heats and/or ventilates your vehicle interior depending on the function and temperature you select. The right knob is the SELECT knob which allows you to select heating or ventilation and determine where the air will be directed. The TEMP knob setting determines the temperature of the air that flows into the vehicle.

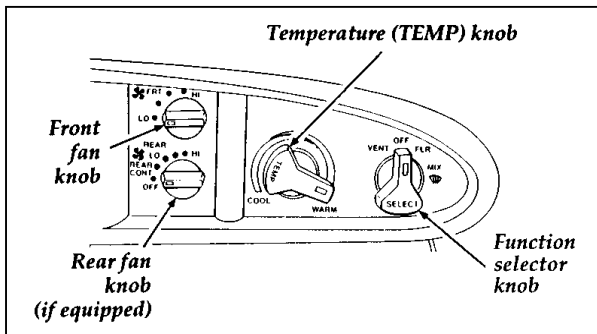
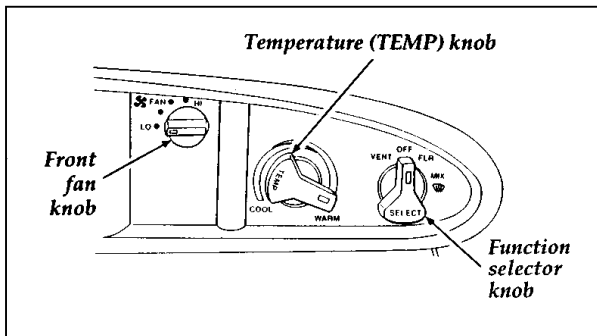



Climate control knobs (heater only)

To turn the heater system on, rotate the SELECT knob to any position except OFF. This turns on the fan and allows airflow into the vehicle.

Temperature selection

The TEMP knob is the rotating knob located at the center of the control with tapered red and blue bands surrounding most of the knob. The wide red part of the band (full right) is the heat area. The wide blue area (full left) is the cool area. Any position selected between full right and full left will give a temperature between the two extremes. The cool temperature you select will not be cooler than the outside temperature.

Fan speed adjustment



The left knob or upper left knob with the  is the fan speed knob. Rotate the  knob to the right to increase fan speed and increase the amount of air entering the vehicle. Four fan speed positions are available.

Function selection

Use VENT to bring outside air through the instrument panel registers. You can heat the air in this position by rotating the TEMP knob into the red area. The air cannot be cooled below the outside temperature regardless of the TEMP knob setting.

Airflow will be to the floor when FLR is selected. The air can be heated by rotating the temperature knob into the red area.

Select MIX to get air to the floor and windshield defrosters at the same time.

Select  to obtain maximum airflow to the windshield. Rotate the TEMP knob into the red area for the air temperature required to defrost. Rotate the  knob to increase or decrease the airflow.

Operating Tips

The following tips will help you to get the most satisfaction from your heater system.

- In humid weather, select  before starting your engine. This will help to prevent windshield fogging. After a few minutes, you may select another airflow position.
- To prevent humidity buildup inside your vehicle, always drive with the heater system turned on.
- Do not put objects under the front seats that interfere with the flow of air to the back seat area.
- Remove any snow, ice, or leaves from the air intake area at the bottom of the windshield.
- For maximum heating, rotate the function selector knob to FLR, the temperature control knob to the red (warm) range, and the fan blower knob to HI.

Auxiliary Heater and Air Conditioner (If equipped)

If your vehicle is equipped with a factory installed auxiliary unit (heater or heater/air conditioner), the front control assembly will include separate switches for FRONT and REAR fan control. Fan speed for front and rear systems can be set as desired by adjusting these switches.

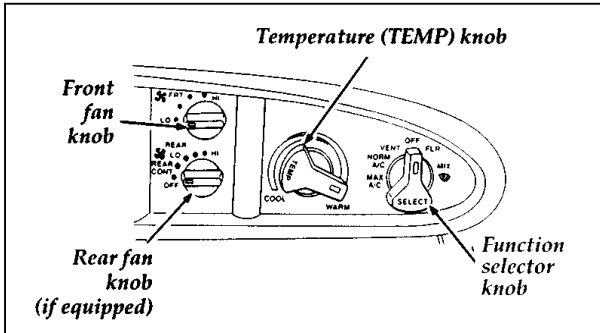

Front control assembly with rear blower knob

In addition, an auxiliary unit fan switch is located on the left side of the vehicle in line with the second row of seats.

To control the auxiliary unit fan speed with this switch, the rear fan switch on the front control must first be set at the REAR CONT (control) position.

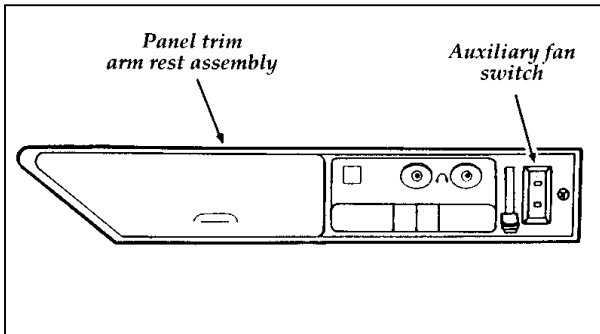

Rear mounted auxiliary fan switch

Rear Window Defroster (If equipped)

The defroster for the rear window clears frost, fog, or thin ice from both the inside and outside of the rear window.

The control switch is located on the instrument panel to the right of the steering column.

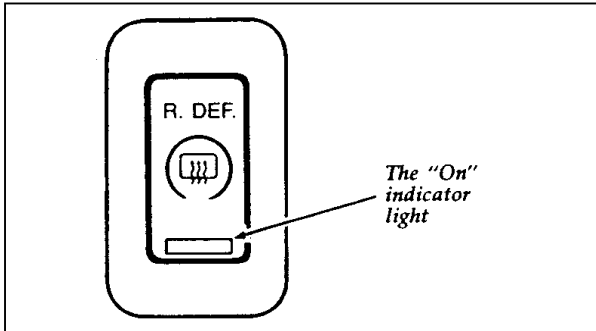

Rear window defroster switch

To defrost the rear window:

1. Clear any snow or ice from the rear window.
2. Get in your vehicle and start the engine.
3. Press the switch. The indicator light will turn on.

The defroster turns off automatically after approximately 10 minutes. If the window is not clear, turn on the defroster again. It will also automatically shut off any time the engine is shut off.

NOTE: Never use sharp instruments or window cleaners with abrasives to clean the inside of your rear window. If you do, you may damage the heating elements that are bonded to the inside of the rear window and cause damage to the rear window defroster.

Rear Window Wiper and Washer (If equipped)

The rear window wiper control switch is located on the instrument panel to the right of the steering column.

To wash and wipe the rear window:

1. Push the top of the switch to turn on the wipers.
2. Push and hold the WASH control switch for a constant spray.
3. Release to the outer position. The spray will stop and the wipers will remain running.
4. Push the top of the switch to stop the wipers.

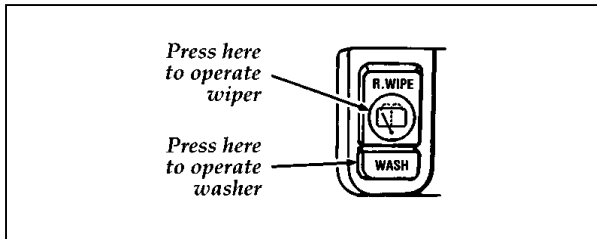

Rear window wiper/washer control button

The Interior and Exterior Lights

Turning On the Exterior Lights

To turn on your headlamps, parking lamps, marker lamps, license plate lamps and tail lamps, use the headlamp switch to the left of the steering column.

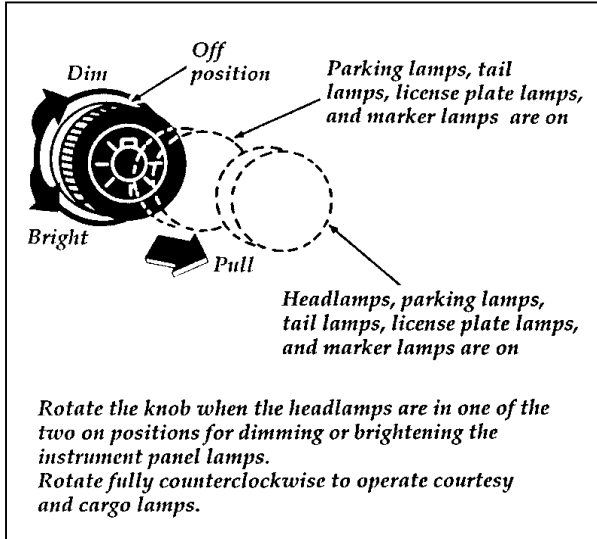

Master lighting switch

Daytime Running Light System

(Canadian vehicles only)

The Daytime Running Light (DRL) system turns the high beam headlamps on, with a reduced light output, when:

- The headlamp system is in the OFF position, and
- The vehicle is running, and
- The vehicle has a fully released parking brake.

NOTE: You may notice that the lights flicker when the vehicle is turned on or off. This is a normal condition.

| |
|----------------------------------------------------------------------------------------------------------------------------------------------------------------------------------------|
|  WARNING |
| <p>The Daytime Running Light (DRL) system will not illuminate the tail lamps and parking lamps. Turn on your headlamps at dusk. Failure to do so may result in a collision.</p> |

Instrument Panel Illumination

The instrument panel lights can be turned on by pulling the headlamp switch toward you to either the first or outer position. You can brighten or dim the instrument panel lights by rotating the headlamp switch knob.

High-mount Brakelamp

The high-mount brakelamp is located above the rear window on liftgate models, and on the roof above the rear doors on dual rear door models.

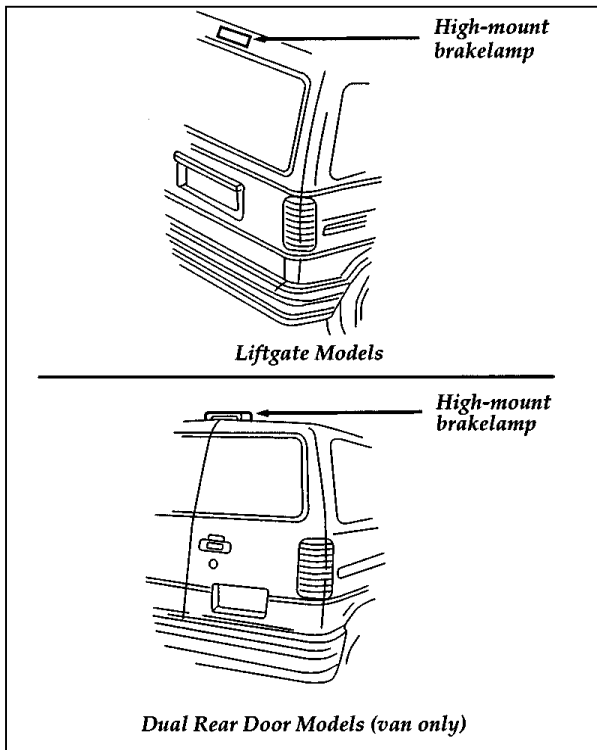

High-mount brakelamp

Illuminated Entry System (If equipped)

If your vehicle is equipped with this option, the interior courtesy lamps and dome lamp will light when either outside front door handle is raised. They will turn off automatically after approximately 25 seconds or when the ignition key is turned to ON or ACC.

Radio

For information about the radio in your vehicle, refer to the *Electronic Sound Systems* chapter in this Owner Guide.

Clock Controls on Electronic Radios

The electronic radios have a built-in clock. For complete operating instructions, refer to the *Electronic Sound Systems* chapter in this Owner Guide.

Ignition

Understanding the Positions of the Ignition

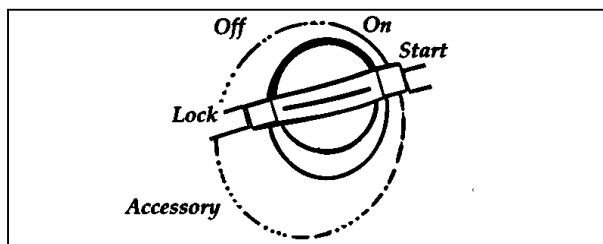

The positions of the key in the ignition lock cylinder.

ACCESSORY allows some of your vehicle's electrical accessories such as the radio and the windshield wipers to operate while the engine is not running.

LOCK locks the steering wheel and gearshift lever.

LOCK is the only position that allows you to remove the key. The LOCK feature helps to protect your vehicle from theft.

If your key is stuck in the LOCK position and will not turn, move your steering wheel left or right until the key turns freely.

OFF allows you to shut off the engine and all accessories without locking the steering wheel or the automatic transmission gearshift lever.

ON allows you to test your vehicle's warning lights (except the brake system warning light) to

make sure they work before you start the engine. The key returns to the ON position once the engine is started and remains in this position while the engine runs.

START cranks the engine. Release the key once the engine starts so that you do not damage the starter. The key should return to ON when you release it. The START position also allows you to test the brake warning light.

The Turn Signal Lever

You can use the turn signal lever on the left side of the steering column to:

- operate the turn signals and cornering lamps
- turn the high beams on/off
- flash the lamps
- turn the windshield wipers and washer on/off

Turn Signals

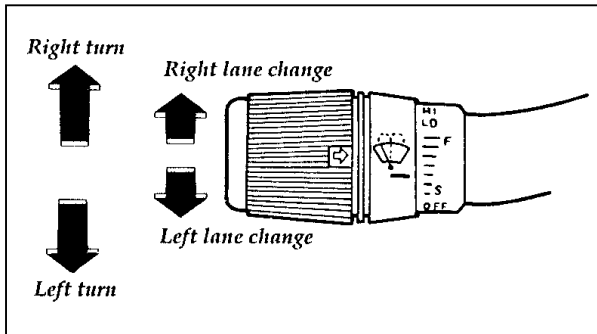

Turn signal operation

If the turn indicator light in the instrument panel does not illuminate or remains on (doesn't flash) when you signal a turn, the turn signaling system is malfunctioning. Have this condition

corrected as soon as possible, but make sure that you use the accepted hand signals in the meantime.

High Beams and Flashing the Lamps

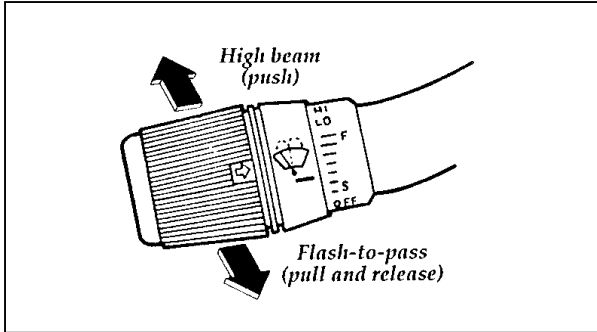

Headlamp high beam and flash-to-pass operation

Windshield Wipers and Washer

To turn on the windshield wipers, the ignition key must be turned to the ON or ACC position.

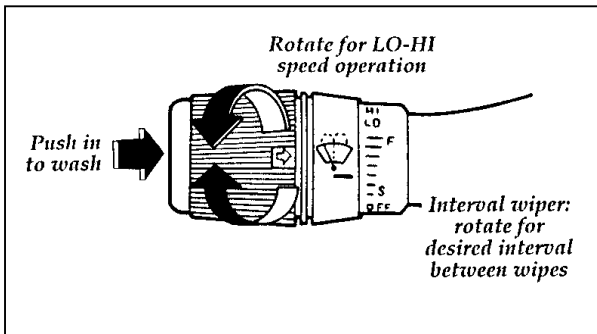

Interval wiper on turn signal lever — wiper and washer operation

To set the interval wipers, rotate the knob at the end of the turn signal lever toward or away from the instrument panel to the interval operation you desire.

To clean the windshield, push in the end of the wiper knob. For a constant spray, keep the knob pushed in. After you release the knob, the wipers operate for two to three cycles before turning off (if wipers were off) or returning to the selected setting.

NOTE: The addition of bug shields to the front of the vehicle (e.g., shields) may adversely affect the windshield washer system from delivering fluid to the windshield. Devices such as shields are not recommended for your Ford vehicle.

Do not try to clean the windshield when the washer fluid container is empty or activate the washers at any time for more than 15 seconds continuously. This could damage the washer pump system.

⚠ WARNING

Always warm up the windshield with the defroster before you use the washer fluid. In freezing weather, the washer solution may freeze on the windshield and obscure your vision.

For information about refilling the washer fluid or replacing your windshield wiper blades, see *Windshield washer fluid and Wipers* in the Index.

Gearshift Lever

The gearshift lever on your Aerostar is mounted on the steering column. On the end of the gearshift lever is the OVERDRIVE OFF button. For additional information about the gearshift lever and the OVERDRIVE OFF button, see the *Driving* chapter.

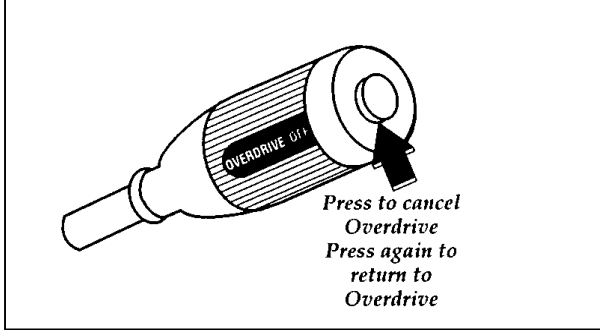

Overdrive off button

OVERDRIVE OFF Light on Gearshift Lever

This light indicates the operating range of the transmission. The word OFF illuminates on the lever when the OVERDRIVE OFF button is depressed.

Hazard Flasher Switch

The hazard flasher switch is located on the top of the steering column. For more information, refer to *Hazard Flasher* in the *Roadside Emergencies* chapter.

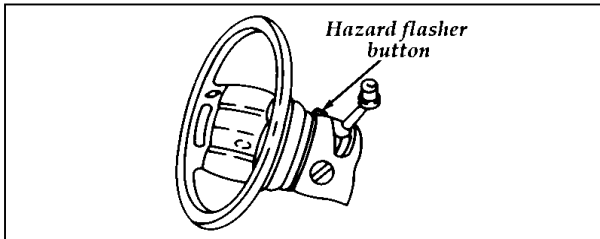

Hazard flasher

Tilt Steering (If equipped)

⚠ WARNING

Never adjust the steering wheel when the vehicle is moving.

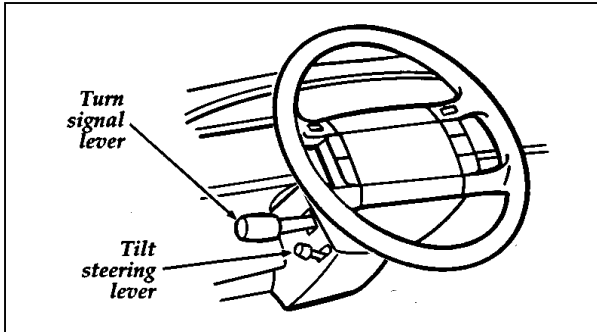

Turn signal and tilt steering release lever

To change the position of the steering wheel, pull the release lever on the column toward you. Tip the steering wheel to the desired position. Release the lever to lock the steering wheel in place.

Be sure the steering wheel locks in a notch. It is not infinitely adjustable. Do not adjust the steering wheel while the vehicle is in motion.

Speed Control (If equipped)

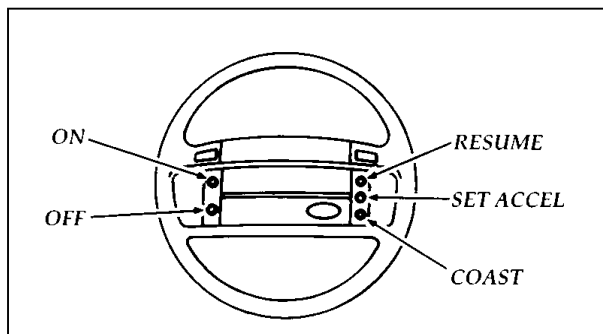

Speed control switches on the steering wheel

To Turn Speed Control Off

Press OFF

OR

Turn off the vehicle ignition.

Once speed control is switched off, the previously programmed set speed will be erased.

To Turn Speed Control On

Press ON

To Set A Speed

Press the SET ACCEL. For speed control to operate, the speed control must be ON and the vehicle speed must be greater than 30 mph (km/h).

If you drive up or down a steep hill, your vehicle speed may vary momentarily slower or faster than the set speed.

Speed control cannot reduce the vehicle speed if it increases above the set speed on a downhill. If your vehicle speed is faster than the set speed while driving on a downhill in **D** (Overdrive),

you may want to shift to the next lower gear to reduce your vehicle's speed.

If your vehicle slows down more than 10 mph (16 km/h) below your set speed on an uphill, your speed control will disengage. Pressing RESUME will re-engage it.

⚠ WARNING

Do not use the speed control in heavy traffic or on roads that are winding, slippery, or unpaved.

To Set a Higher Set Speed

Press and hold SET ACCEL. Release the switch when the desired vehicle speed is reached.

OR

Press and release SET ACCEL. Each press will increase the set speed by 1 mph (1.6 km/h).

OR

You may accelerate with the accelerator pedal at any time during speed control usage. Releasing the accelerator pedal will return your vehicle speed to the previously programmed set speed.

To Set a Lower Set Speed

Press and hold COAST. Release the switch when the desired speed is reached.

OR

Press and release COAST. Each press will decrease the set speed by 1 mph (1.6 km/h).

OR

Depress the brake pedal. When the desired vehicle speed is reached, press SET ACCEL.

⚠ WARNING

Do not shift the transmission into N (Neutral) with the speed control on.

To Disengage Speed Control

Depress the brake pedal.

Disengaging the speed control will not erase the previously programmed set speed.

To Return to a Set Speed

Press RESUME. For RESUME to operate, the vehicle speed must be faster than 30 mph (48 km/h).

Use of radio transmitting equipment that is not Federal Communications Commission (FCC) or in Canada the Canadian Radio and Telecommunications Commission (CRTC) approved may cause the speed control to malfunction. Therefore, use only properly installed FCC (CRTC in Canada) approved radio transmitting equipment in your vehicle.

Dome/Map/Reading Lamps (If equipped)

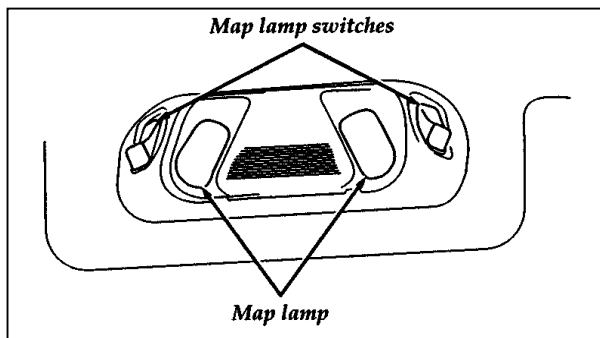

Map lamps

The map lamps are located inside the dome lamp assembly, on each side of the dome lamp. Each lamp has its own switch.

The front dome lamp, cargo lamp and stepwell lamp, if so equipped, will operate as courtesy lamps when either of the front doors, side cargo door, liftgate or dual rear door is opened.

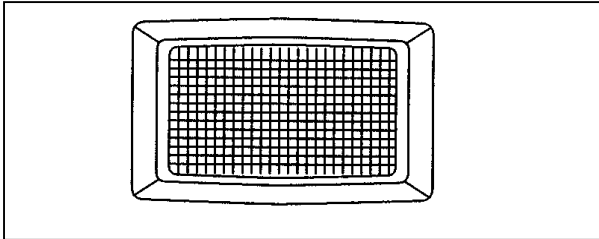

Rear cargo lamp

Your vehicle has a variety of features designed for your comfort, convenience and safety. Read this chapter to find out about standard and optional features.

Doors

Door Handles and Locks



Inside handles

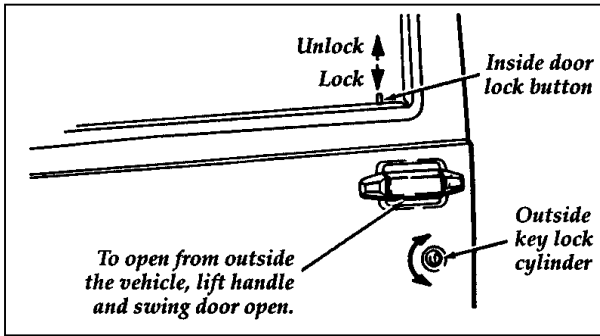

Outside handles and locks

Anti-theft front door lock knobs

Anti-theft lock knobs are designed to preclude unlocking the door by pulling up on the bullet type lock knob. To unlock and open the front door from the inside of the vehicle, pull on the inside door handle.

Sliding Door

With the door unlocked, unlatch the sliding door by pulling the inside handle to the rear, or by pulling the outside handle out and rearward. To close, push the inside handle forward or pull the outside handle forward.

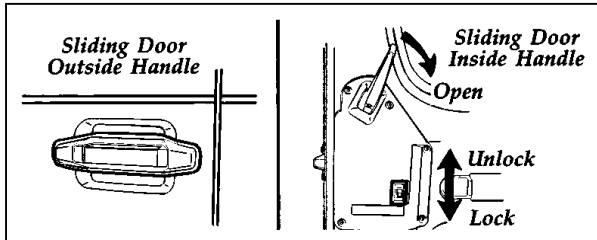

Sliding door handles

Liftgate

Liftgate opening procedure

1. Insert the key into the lock and turn it counterclockwise. You can also unlock the latch (but not release it) with the power door lock system (if equipped).
2. Reach under the license plate light shield and release the liftgate latch by squeezing the paddle handle rearward.
3. To make the gate swing up to the fully opened position, pull back and upward on the latch paddle handle.

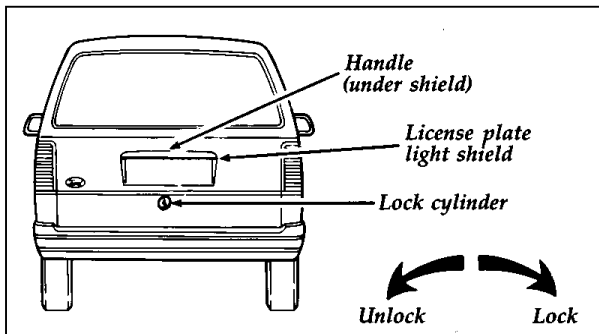

Opening the liftgate

Make certain that you close the liftgate door and window before driving your vehicle. If you do not, possible damage may occur to the liftgate door lift cylinders and attaching hardware.

⚠️ WARNING

Make sure that the liftgate door and/or window are closed to prevent exhaust fumes from being drawn into the vehicle. This will also prevent passengers and cargo from falling out. If you must drive with the liftgate door or window open, keep the vents open so outside air comes into the vehicle.

Liftgate closing procedure

1. To make the liftgate swing downward, reach up and pull the lower edge of the liftgate (or the loop handle on the inner trim panel of vehicles with this option) and pull downward.
2. When you have pulled down the liftgate enough so that you can reach the license plate light shield, push the shield down and forward to close the latch and liftgate. At this point, the latch is not locked.

3. You can lock the liftgate latch by pushing down the lock button before you pull down and close the liftgate. You can also lock the liftgate latch by inserting your vehicle's door key and turning it clockwise after you have closed the liftgate, or by using the power door locks (if equipped).

The liftgate area is only intended for cargo, not passengers. You can open and close the liftgate from outside the vehicle. It cannot be opened from inside the cargo area.

Dual Rear Cargo Door (If equipped)

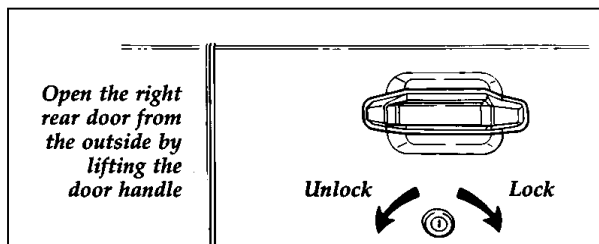

Opening the right rear door

To open the left rear door, open the right rear door and then pull up on the tee-shaped handle located on the inside of the left rear door.

When closing the dual rear cargo doors, remember to close the left rear door first.

 **WARNING**

Do not operate your vehicle with the rear double doors open.

Power Door Locks (If equipped)

The power door lock switches are located in the front doors. To lock all doors push the switch marked LOCK. To unlock all doors push the switch marked UNLOCK.

Memory lock (sliding door)

Your vehicle has a sliding door memory lock feature that does not require the sliding door to be closed before using the power locks. The locking function will activate after the door is closed.

The manual door locks will override the power door lock controls.

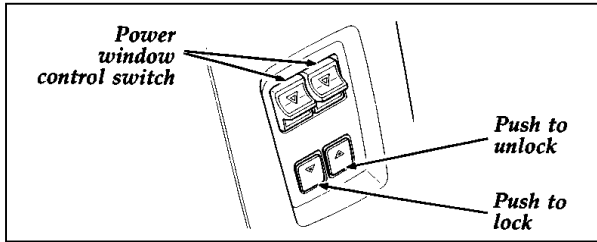

Power door lock controls

Windows

Sliding side windows

To open or close the sliding side windows, follow the instructions listed below.

Opening the sliding window

1. To open the window, pull the rear portion of the latch handle rearward.
2. Slide the window open.

Closing the sliding window

1. To close the window, push the latch handle toward the front of the vehicle.
2. Slide the window forward to engage the latch handle on the striker.

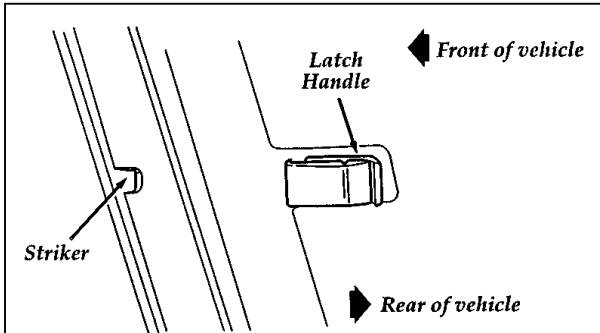

Opening the sliding side window

Using the Power Windows (If equipped)

Each front door has a power control that opens and closes the window on that door. The driver's door has a master control switch that operates both front door windows. You must place the ignition switch in the ON or ACC position to use your power window controls.

WARNING

Make sure that the liftgate door and/or window are closed to prevent exhaust fumes from being drawn into the vehicle. This will also prevent passengers and cargo from falling out. If you must drive with the liftgate door or window open, keep the vents open so outside air comes into the vehicle.

WARNING

Do not let children play with the power windows.

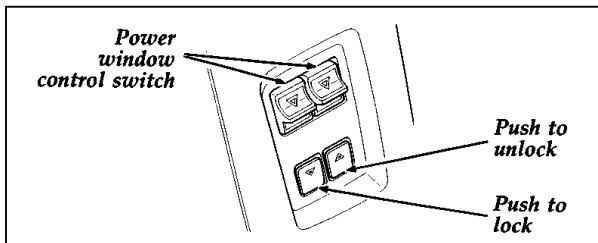

Power window controls — driver-side shown

Mirrors

For vehicles without rear door windows, the right-hand side mirror is a flat glass mirror. All other vehicles have convex right-hand side view mirrors. Convex mirrors have a curved surface and will show a wider view of the lane next to and behind your vehicle.

WARNING

The right side view mirror makes objects appear smaller and farther away than they actually are.

Dual Electric Remote Control Mirrors (If equipped)

To adjust the remote controlled side mirrors:

1. Locate the switch in the driver's door trim panel.
2. Select the right or left mirror by moving the center switch to the left-hand or right-hand position. The midway position moves neither the left-hand or right-hand mirror.
3. Press the appropriate side of the square marked by an arrow indicating the direction of adjustment.

4. Return the center switch to the middle position to keep the mirror in place.

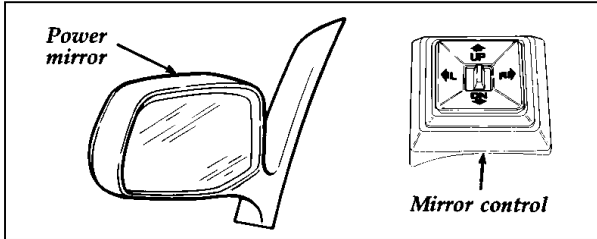

Power mirror control

Do not clean the plastic housing of any electric mirror with gasoline or other petroleum-based cleaning products.

Console

Your vehicle may have a full console. The full console has the features shown in the illustration below.

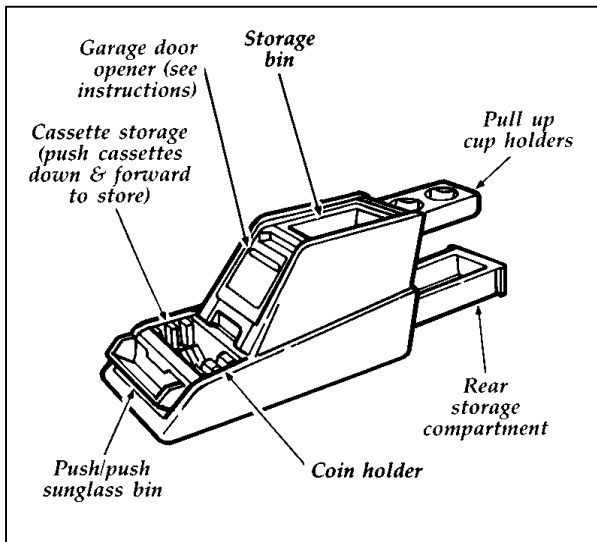

The features on the console

Garage Door Opener Storage

At the center of the console, a compartment is provided for storage of a garage door opener transmitter. In its stored position, the transmitter can be activated by pressing on the compartment door.

To install the transmitter:

1. Push down on latch.
2. Open door by moving hand towards front of vehicle while maintaining pressure on latch (Figure 1).

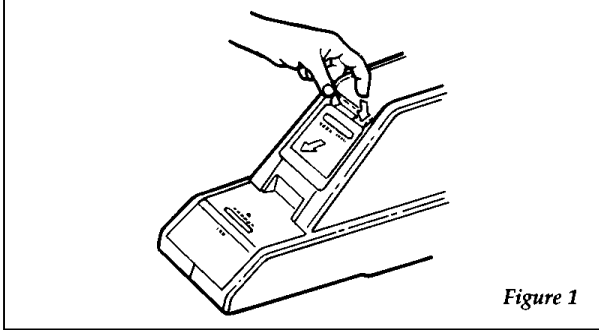

Figure 1

3. Remove the backing from the self-adhesive side of the Velcro™ (supplied with the console) and apply it to the back of your transmitter.
4. Install your transmitter into the compartment, making sure the actuator button of your transmitter is in line with one of the pegs on the door when the door is closed (Figure 2).

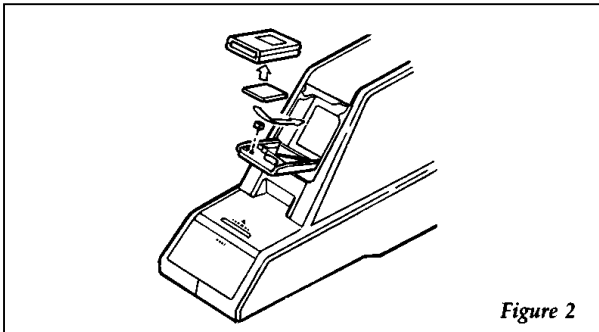

Figure 2

5. Once the transmitter is installed, the actuation peg on the door in line with your transmitter button may need to be adjusted for proper function. This can be done using the button height adjustment pegs (located on the compartment door). Add one peg at a time until pressing the door actuates the transmitter button (Figure 3).

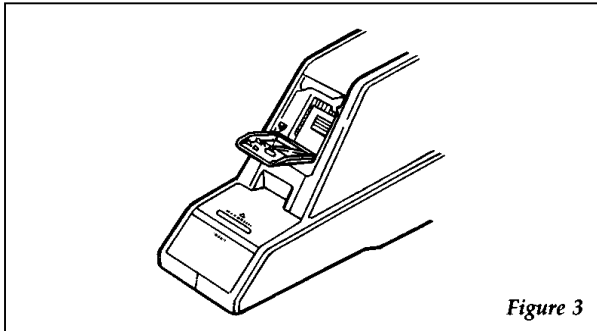

Figure 3

6. By properly adjusting the actuation peg height, you will be able to actuate your garage door by pressing the door as shown (Figure 4).

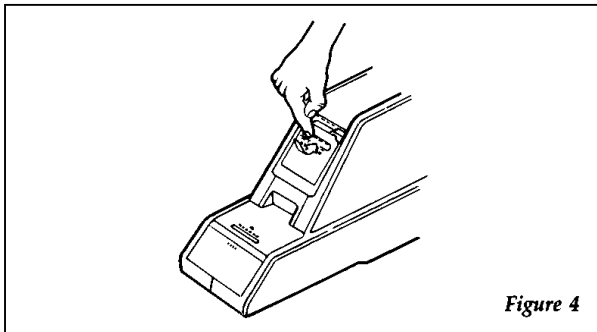

Figure 4

Seating and Safety Restraints

Seats

Adjusting the Front Seat Manually

You can move the driver seat forward or backward. If your vehicle is equipped with the optional reclining bucket seat, you can also tilt the seatback up to 30 degrees rearward.

The front passenger seat cannot be adjusted.

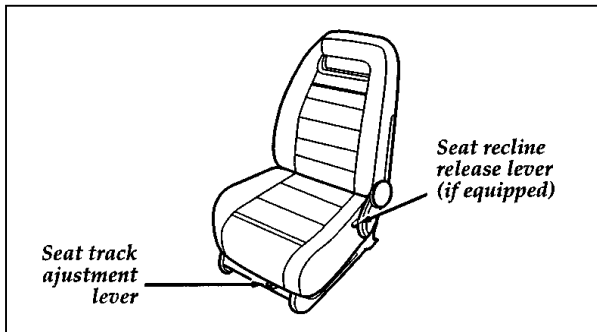

Seat adjustment levers

⚠ WARNING

Never adjust the driver's seat or seatback when the vehicle is moving.

⚠ WARNING

Do not pile cargo higher than the seatbacks to avoid injuring people in a collision or sudden stop.

⚠ WARNING

Always drive and ride with your seatback upright and the lap belt snug and low across the hips.

⚠ WARNING

Children should always ride with the seatback in the fully upright position.

To move the seat forward or backward:

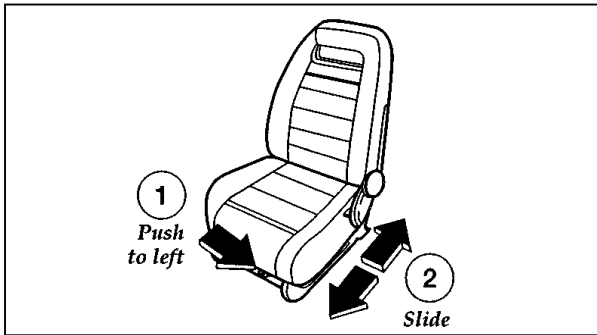

To recline the seatback:

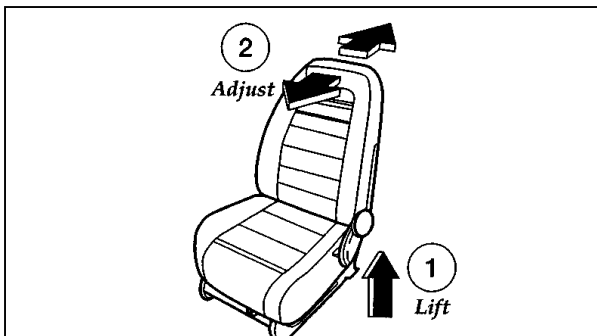

E-Z Access Operation — Passenger Side Rear Captain's Chair (Optional Quad Buckets)

To provide easy access to the rear of the vehicle, the passenger side rear captain's chair can be tilted forward.

To tilt seat forward:

1. Put the seatback in the upright position.
2. Lift upward on the lower handle on the right (outboard) side of the seat.
3. The seat can now be tilted forward.

To latch the seat in its normal position, push seatback rearward until it is latched in position.

Quick Release Rear Captain Chairs

To remove:

1. For right hand seats, lift and rotate the seat latch handle (located under the seat) rearward, causing the J hook to disengage from the front floor well retainer.

For left hand seats, lift and rotate the seat latch handle (located under the seat) rearward, causing the J hook to disengage from the front floor well retainer. Disengage the lap/shoulder safety belt from the seat by inserting a key or similar device into the slot in the detachable anchor and lifting upward. Stow the tongue end of the detachable anchor as shown.

2. Push the seat assembly rearward to disengage the front and rear floor hooks and lift the seat assembly from the vehicle.

To install the rear bucket seat:

1. Lift the seat assembly into the vehicle and drop the front and rear floor hooks into the floor wells at a point just behind the floor attachment pins.
2. Rotate the seat latch handle forward, causing the J hook to engage over the front of the foremost well retainer.
3. For right hand seats, continue rotating the seat latch handle until it comes to a complete stop on the top of the tube. This will cause the seat assembly to slide forward, engaging the front and rear floor hooks with the floor well retainers.

For left hand seats, push the seat latch handle downward to a full stop. This locks the seat in position. Before you engage the safety belt, be sure it is not twisted. Remove any twist, then insert the tongue end of the detachable anchor into the detachable anchor until you hear a “snap” and feel the latch engage.

⚠ WARNING

Check to see that the seat and seatback are latched securely in position. Keep floor area free of objects that would prevent proper seat engagement. Never attempt to adjust the seat while the vehicle is in motion.

Two and Three Passenger Bench Seats and Seat Bed Assemblies (If Equipped)

NOTE: If your vehicle is equipped with a Built-In Child Seat, make sure the child seat is properly stowed before operating the seat bed.

To remove seat assembly:

1. Disengage the lap/shoulder safety belt from the seat by inserting a key or screwdriver into the slot in the detachable anchor and lifting upward. Stow the tongue end of the detachable anchor as shown in the illustration.

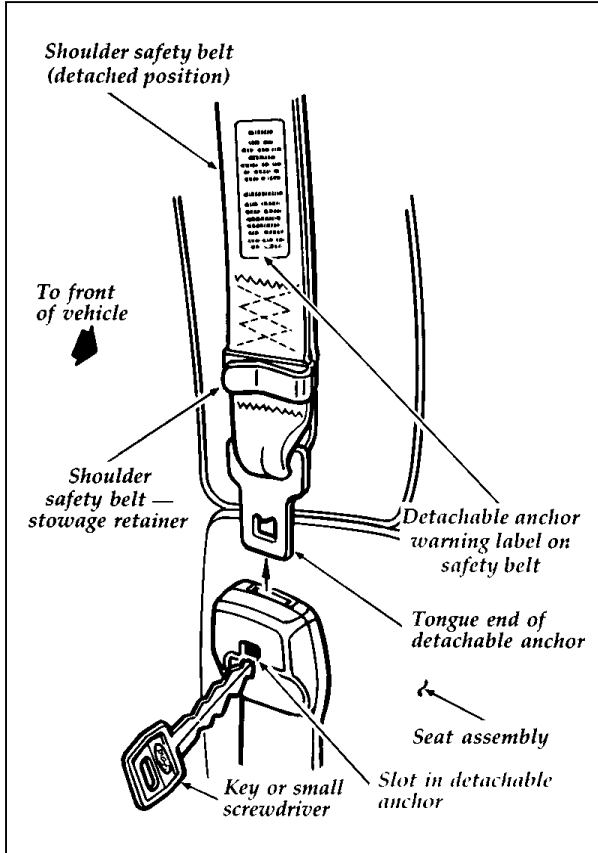

Location of the detachable anchor warning label on safety belt

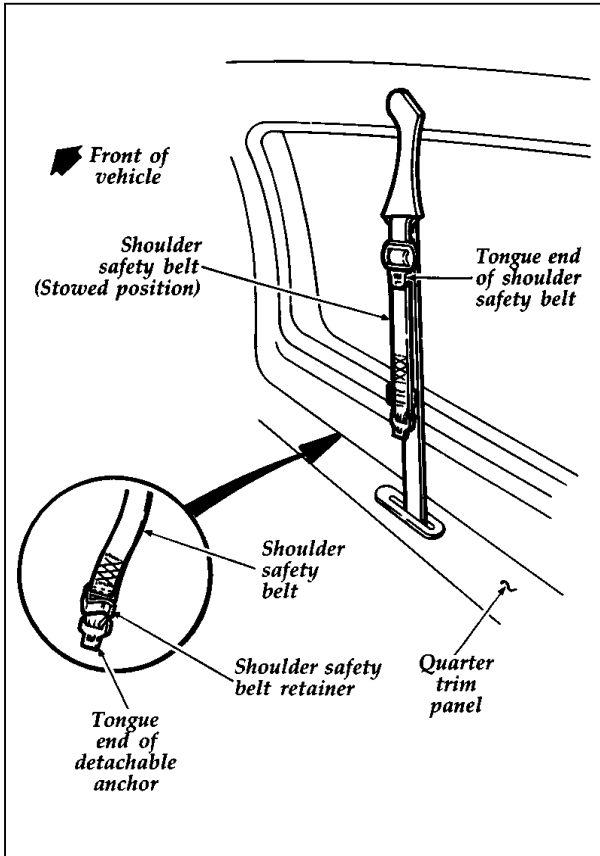

Rear seat shoulder safety belt — stowage (with seat removed)

⚠ WARNING

When reinstalling a rear seat in your vehicle it must be placed in its original position. Improper installation of the seat will prevent correct use of the safety belts and could increase the risk of injury. Refer to the warning label on the seat belt.

2. Fold the seatback forward and latch it in the down position (bench seat only).
3. Rotate the seat latch handles (located under the seat near the floor) upward, causing the latch hooks to disengage from the floor attachment.
4. Lift seat at rear and rotate about the forward attachment. When seat latches are clear of floor attachments, release the latch handles.
5. Pull the seat rearward to disengage it from the front floor pins.

Be careful that the latches are not damaged when the seats are stored.

To install the seat assembly:

1. Clear the area of debris around the seat floor attachments.
2. With the seatback in a folded and latched position (bench seat only), place the seat assembly in your vehicle and engage the front seat hooks onto the forward attachment pin in the floor wells.
3. Rotate the seat downward and engage the latch into the rear floor attachment. Lifting of the latch handles is not required for installation.

4. Ensure that the latch handles are fully seated in the down position.
5. Before you engage the safety belt, be sure it is not twisted. A twisted safety belt may cause the retractor to work improperly. Remove any twist, then insert the tongue end of the detachable anchor into the detachable anchor until you hear a “snap” and feel the latch engage. Refer to the previous illustration.

The two passenger bench or bed seat must be installed in the first row behind the front seats on wagons with seven passenger seating.

To fold down the rear seatback:

To lower the rear seatback down to its cargo or bed position, release the seatback latch by moving the release lever forward for the bench seat or upward for the seat bed. Then fold the seatback down. The latch will re-engage in the cargo position.

To raise the seatback, release the seatback latch and rotate the seatback upwards until the latch re-engages. (A slight downward pressure on the bench seat seatback will reduce effort on the latch.)

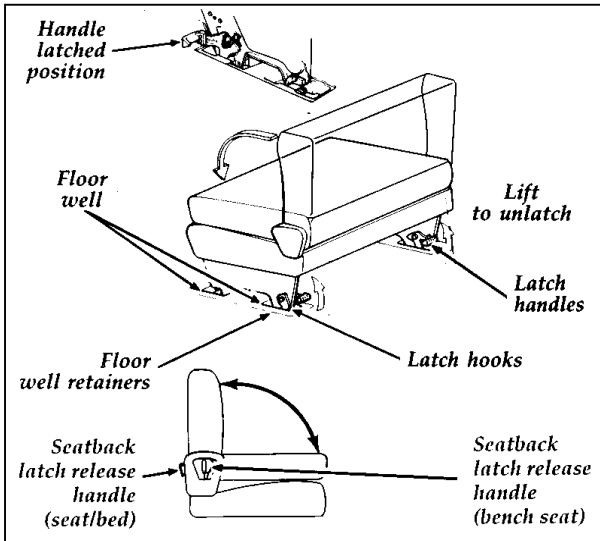

Installation and removal of the second and third passenger bed and bench seat

⚠ WARNING

Never adjust the driver's seat or seatback when the vehicle is moving.

⚠ WARNING

Always latch the vehicle seat to the floor, whether the seat is occupied or empty. If not latched, the seat may cause injury during a sudden stop.

⚠ WARNING

Before using the seat, make sure that the latch hooks are securely locked around the floor pins.

Seat/bed conversion (If Equipped)

Vehicles equipped with the seat/bed can be either a two passenger or three passenger seat.

To convert the seat/bed to a bed:

1. Pull up the release lever located on right hand side of the seat, and at the same time push the seatback rearward.
2. Push the top of the seatback down until it latches.

The two passenger seat cushion will move forward when going from the seat to the bed position.

To convert the bed to a seat:

1. While in front of the seat, pull the release lever up and at the same time pull the seatback up. Raise the seatback to the full upright and locked position.
2. Make sure the safety belts are free and available for use.

| |
|-----------------------------------------------------------------------------------------------------------------------------|
|  WARNING |
| The seat/bed should not be occupied while the vehicle is moving unless it is in the upright, fully-latched position. |

Using the Lumbar Support and Side Bolsters

Adjusting the Lumbar Support (If equipped)

To adjust the lumbar pad, turn the knob clockwise or counterclockwise.

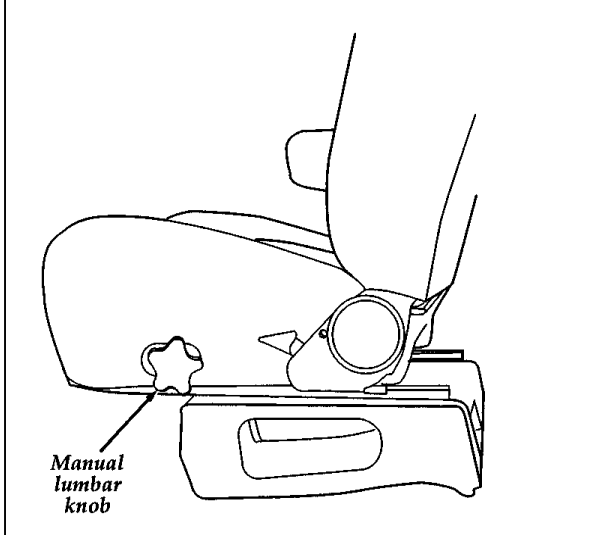

Manual lumbar knob

Underseat Stowage Drawer (If equipped)

If your vehicle is equipped with the front passenger seat drawer, open it by moving the latch lever upward and pulling the drawer toward the front of the vehicle. To remove the drawer, pull past the stop tab on the back of the drawer.

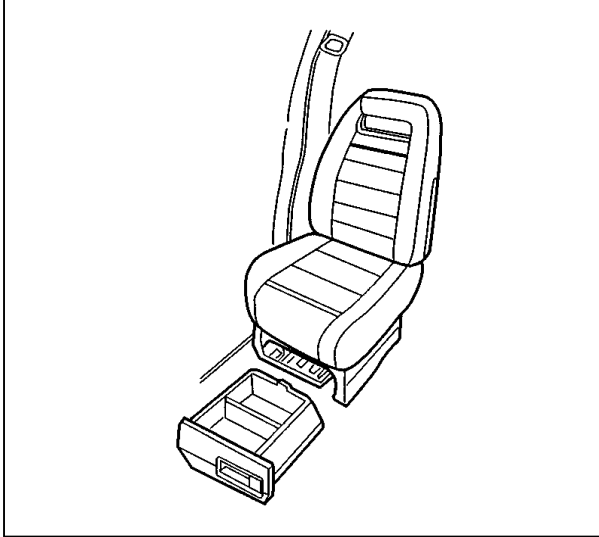

Underseat stowage drawer — RH front passenger seat only

Important Safety Belt Information

The use of safety belts helps to restrain you and your passengers in case of a collision. In most states and in Canada, the law requires their use.

Safety belts provide best restraint when:

- the seatback is upright
- the occupant is sitting upright (not slouched)
- the lap belt is snug and low on the hips
- the shoulder belt is snug against the chest
- the knees are straight forward

To help you remember to fasten your safety belt, a warning light may come on and a chime may sound. See *Safety Belt Warning Light and Chime* in the *Instrumentation* chapter.

See the following sections in this chapter for directions on how to properly use these safety belts. Also see *Safety Restraints for Children* in this chapter for special instructions about using safety belts for children.

⚠️ WARNING

Always drive and ride with your seatback upright and the lap belt snug and low across the hips.

⚠️ WARNING

Each seating position in your vehicle has a specific safety belt assembly which is made up of one buckle and one tongue that are designed to be used as a pair. 1) Use the shoulder belt on the outside shoulder only. Never wear the shoulder belt under the arm. 2) Never swing it around your neck over the inside shoulder. 3) Never use a single belt for more than one person.

⚠️ WARNING

Children should always ride with the seatback in the fully upright position.

⚠️ WARNING

Never drive or ride with a twisted or jammed safety belt. If you cannot untwist or unjam the safety belt, see the nearest qualified technician immediately.

⚠ WARNING

Never let a passenger hold a child on his or her lap while the vehicle is moving. The passenger cannot protect the child from injury in a collision.

⚠ WARNING

Lock the doors of your vehicle before driving to lessen the risk of the door coming open in a collision.

Combination Lap and Shoulder Belts

While your vehicle is in motion, the combination lap and shoulder belt adjusts to your movement. However, if you brake hard, turn hard, or if your vehicle receives an impact of 5 mph (8 km/h) or more, the lap/shoulder belt locks and helps reduce your forward movement.

After you get into your vehicle, close the door and lock it. Then adjust the seat to the position that suits you best.

Pull the combination lap/shoulder belt from the retractor so that the shoulder portion of the belt crosses your shoulder and chest. Be sure the belt is not twisted. If it is, remove the twist. Insert the belt tongue into the proper buckle until you hear a snap and feel it latch. Make sure the tongue is securely fastened to the buckle by pulling on tongue.

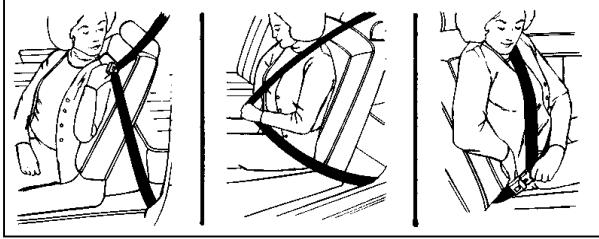

Fastening the front seat combination lap and shoulder belt

NOTE: Be sure to read and understand *Important Safety Belt Information* at the beginning of this chapter.

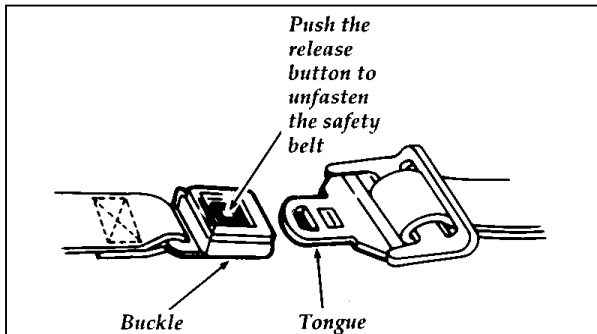

Unfastening the combination lap and shoulder belts — front and rear outboard seating positions

While the belt retracts, guide the tongue to its original position to prevent it from striking you or the vehicle.

Safety Belts for Front Outboard Passenger and Rear Outboard Seating Positions

Your vehicle is equipped with a dual locking mode retractor on the **shoulder** belt portion of the combination lap/shoulder safety belt for the front seat outboard passenger and rear outboard passengers.

Dual locking mode retractors operate in two ways:

Vehicle sensitive (emergency) locking mode

In this operating mode, the shoulder belt retractor will allow the occupant freedom of movement, locking tight only on hard braking, hard cornering or impacts of approximately 5 mph (8 km/h) or more. The retractor can also be made to lock by pulling the belt out quickly.

Automatic locking mode

In this operating mode, the shoulder belt retractor will be automatically locked and will remain locked when the combination lap/shoulder safety belt is buckled, and does not allow the occupant freedom of movement. This mode provides the following:

- A tight lap/shoulder belt on the occupant.
- Child safety seat installation.

This mode **must be used** when installing a child safety seat on the front passenger seat and rear outboard seats where dual locking retractors are provided.

To switch the retractor from the emergency locking mode to the automatic locking mode, perform the following steps:

1. Buckle the lap/shoulder combination belt.
2. Grasp the shoulder portion of the belt and pull downward until all of the belt is extracted and, when allowed to retract, a clicking sound is heard. At this time, the belt retractor is in the automatic locking mode (child restraint mode).

3. A clicking sound will continue to be heard as the belt is allowed to retract. This indicates that the retractor is in the automatic locking mode.

NOTE: When the combination lap/shoulder belt is unbuckled and allowed to retract completely, the retractor will switch to the vehicle sensitive (emergency) locking mode. See the detailed instructions under *Safety Seats for Children* in this chapter.

Two Passenger Bench or Bedseat (If Equipped)

In addition to anchorages in the floor and roof structures, some rear safety belts have a detachable anchor mounted to the outboard side of the rear seats. This should remain attached, except when removing the rear seats.

Disengaging rear seat safety belts for seat removal

In order to remove the rear seat, the safety belt must be disengaged from the seat. To disengage the safety belt from the seat, insert a key or small screwdriver into the slot provided on the detachable anchor. Then lift upward.

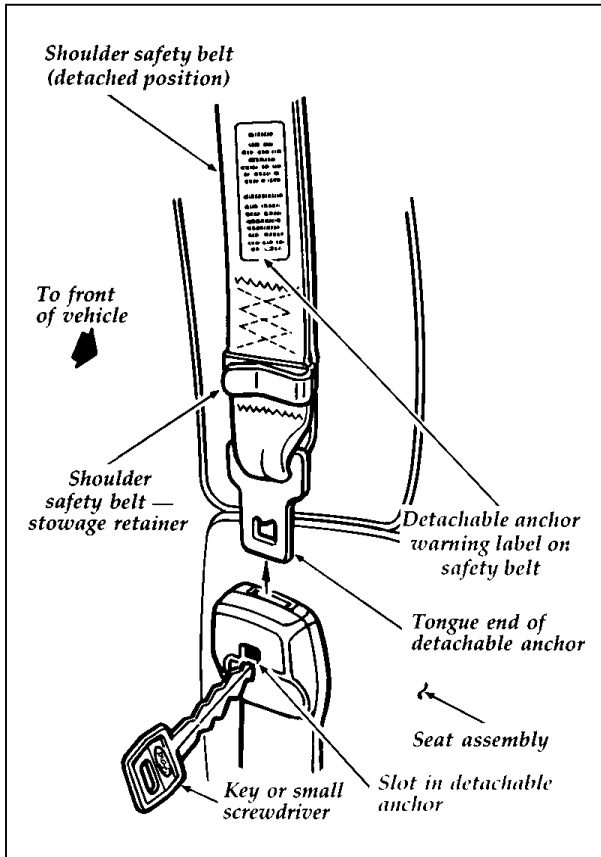

Disengaging safety belt for rear seat removal

Whenever a rear seat has been removed, the tongue end of the detachable anchor must be correctly stowed. See the following illustration.

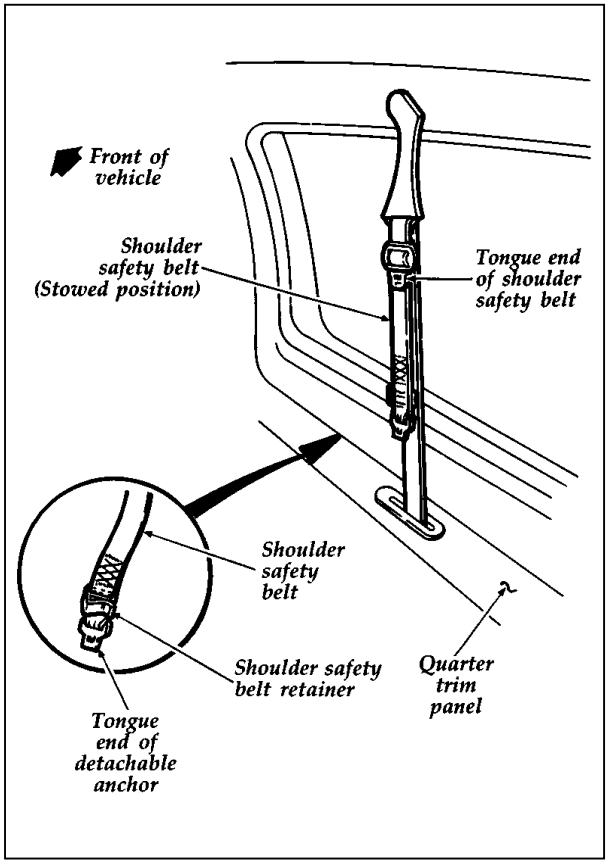

Rear seat shoulder safety belt — stowage (with seat removed)

⚠ WARNING

When reinstalling a rear seat in your vehicle it must be placed in its original position. Improper installation of the seat will prevent correct use of the safety belts and could increase the risk of injury. Refer to the warning label on the seat belt.

After installing the rear seat, make sure the safety belt is not twisted before you insert it into the detachable anchor. A twisted safety belt may cause the retractor to not work properly. Then insert the detachable anchor tongue into the detachable anchor until you hear a “click” and feel the latch engage.

Lap Belts

On the center seat of the rear three-passenger seats you will find a lap-belt without a retractor. You must adjust the lap belt to fit snugly and as low as possible around your hips. Do not wear the lap belt around your waist.

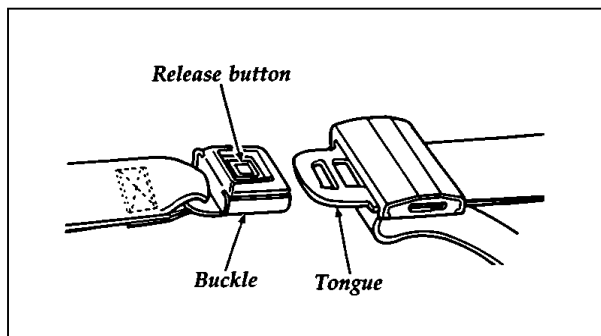

Fastening and unfastening the center rear occupant safety lap belts

Pull the belt across your hips and **insert the tongue into the correct buckle** on your seat until you hear a snap and feel it lock. Make sure the buckle is securely fastened.

If you need to lengthen the belt, unfasten it and tip the belt tongue at a right angle to the belt. Pull the belt tongue over your lap until it reaches the buckle.

If you need to shorten the belt, pull on the loose end of the webbing until the belt fits snugly.

To unfasten the belt, push the release button on the buckle. This allows the tongue to unlatch from the buckle.

 **WARNING**

The lap belts should fit snugly and as low as possible around the hips, not around the waist.

Safety Belt Extension Assembly

For some people, the safety belt may be too short even when it is fully extended. You can add about eight inches (20 cm) to the belt length with a safety belt extension assembly (part number 611C22). Safety belt extensions are available at no cost from your dealer.

Use only extensions manufactured by the same supplier as the safety belt. Manufacturer identification is located at the end of the webbing on the label. Also, use the safety belt extension only if the safety belt is too short for you when fully extended. Do not use extension to change the fit of the shoulder belt across the torso.

Safety Belt Maintenance

Check the safety belt systems periodically to make sure that they work properly and are not damaged.

| |
|--------------------------------------------------------------------------------------------------|
|  WARNING |
|--------------------------------------------------------------------------------------------------|

| |
|---------------------------------------------------------------------------------------------------------------------------------------|
| Failure to follow these instructions will affect the performance of the safety belts and increase the risk of personal injury. |
|---------------------------------------------------------------------------------------------------------------------------------------|

All safety belt assemblies, including retractors, buckles, front seat belt buckle support assemblies (slide bar) (if equipped), shoulder belt height adjusters (if equipped), child safety seat tether bracket assemblies (if equipped), and attaching hardware, should be inspected after any collision. Ford recommends that all safety belt assemblies used in vehicles involved in a collision be replaced. However, if the collision was minor and a qualified technician finds that the belts do not show damage and continue to operate properly, they do not need to be replaced. Safety belt assemblies not in use during a collision should also be inspected and replaced if either damage or improper operation is noted.

How to Untwist or Unjam a Safety Belt Retractor

If you should jam the lap belt retractor by allowing the belt to retract when it is twisted, you can free the webbing with this procedure:

1. Pull on the belt with both hands to tighten it on the retractor spool.
2. Feed the belt back into the retractor until it is completely retracted. Repeat previous step if necessary.

3. Pull the belt out of its holder as far as it will go and untwist the belt or remove the object that is jamming the belt. Let the belt retract.
4. Then, pull the belt out and let it retract several times to make sure that the belt works properly.

For Twisted Rear Outboard Combination Lap and Shoulder Safety Belts — Detachable Anchor

Disengage the detachable anchor tongue from the detachable anchor, remove the twist and re-install the detachable anchor tongue end into the detachable anchor until you hear a snap and feel the latch engage.

Procedure to Correct a Twisted Safety Belt at the “D” Ring (if so equipped) Front and/or Rear Outboard Seating Positions

NOTE: The restraint system shown in the following figures may be different than the restraint system in your vehicle. However, use these figures and this procedure to correct a twisted safety belt at any outboard seating position that has a “D” ring.

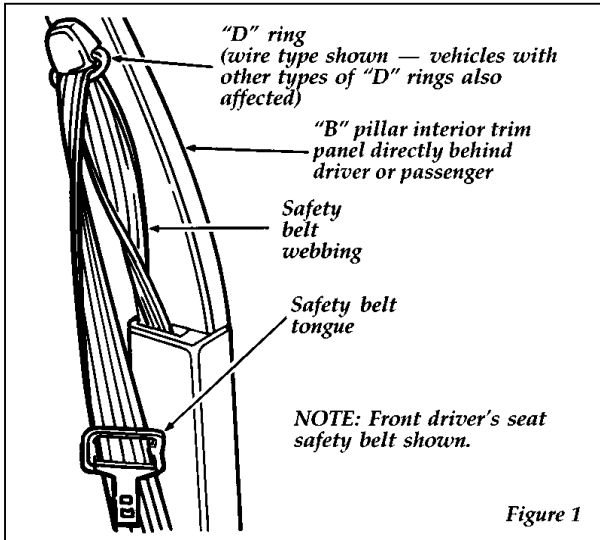

1. Grasp the belt webbing at the "D" ring. See Figure 2.

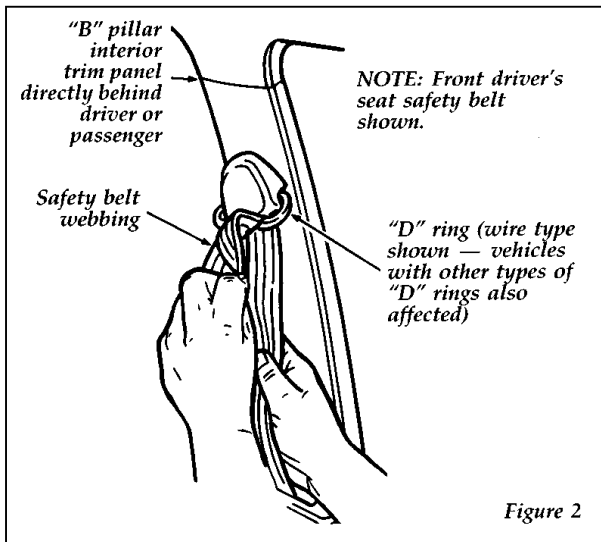
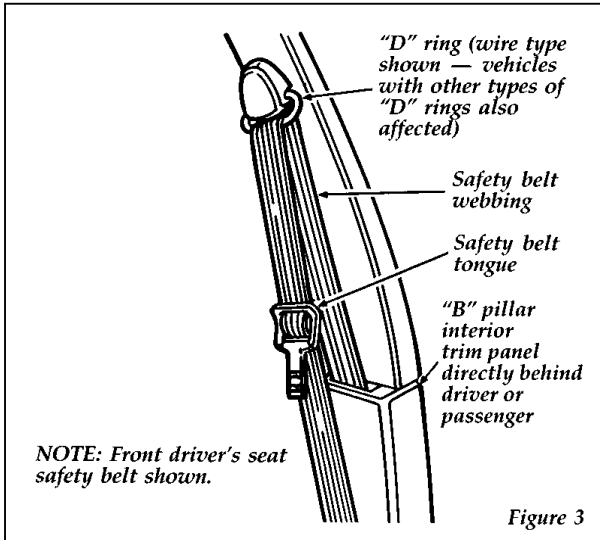

Figure 2

2. Rotate and fold the belt webbing over itself as required to remove the twist.
3. Feed the folded portion of the belt through the "D" ring.
4. When completed, the safety belt should look like Figure 3.



Air Bag Supplemental Restraint System (SRS)

Important Air Bag Precautions

Your vehicle is equipped with a supplemental restraint system designed to work with the safety belts to help protect you and your right front seat passenger in the event of certain collisions described in the section *"How Does the Air Bag Supplemental Restraint System Work?"*

WARNING

All occupants of the vehicle, including the driver, should always wear their safety belts, failure to do so may increase the risk of personal injury in the event of a collision.

⚠ WARNING

Do not place objects or mount equipment on or near the steering wheel or in front of the passenger dashboard area that may come into contact with an inflating air bag. Failure to follow these instructions may increase the risk of personal injury in the event of a collision.

⚠ WARNING

Do not attempt to service, repair, or modify the air bag Supplemental Restraint System or its fuses. See your Ford or Lincoln-Mercury dealer.

⚠ WARNING

If you are close to an inflating air bag, it could seriously injure you. Sit against the seatback and position your seat such that it is as far back from the steering wheel as possible but still allows you to properly control the vehicle.

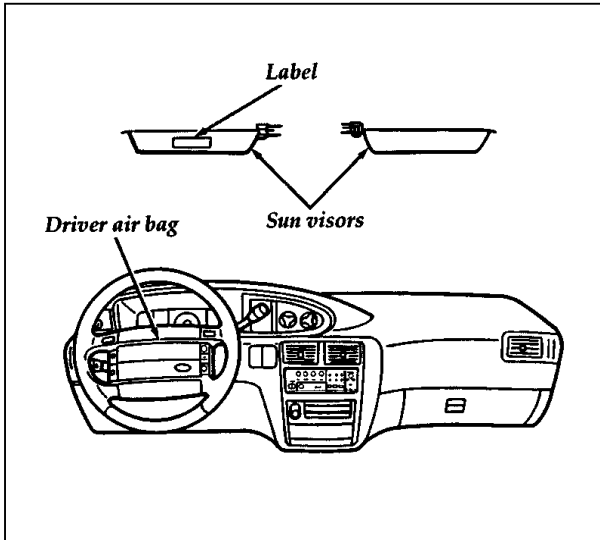

Children and Air Bags

Children should be placed in the rear in an appropriate child safety seat that is properly secured to the vehicle.

⚠ WARNING

Children should always wear their safety belts. Failure to follow these instructions may increase the risk of personal injury in the event of a collision.

⚠ WARNING

Rear-facing child seats and infant carriers should never be placed in the front seats.

NOTE: For additional important safety information on the proper use of seat belts, child seats, and infant seats, please read the entire Safety Restraints chapter in this owner guide.

How Does the Air Bag Supplemental Restraint System Work?

The Air Bag Supplemental Restraint System is designed to activate when the vehicle sustains sufficient longitudinal (lengthwise) deceleration that is equal to or greater than hitting an immovable barrier head on at a range of about 8-14 mph (13-23 km/h). The fact that the air bags did not inflate in a collision does not mean that something is wrong with the system. Rather, it means the forces were not of the type sufficient to cause activation.

If the vehicle is in a moderate or severe frontal collision, the system is activated and the air bags inflate rapidly. After the air bag inflates, it will quickly deflate. After the air bag deployment, you may notice a smoke-like, powdery residue or smell the burnt propellant. This is normal. The residue may consist of cornstarch or talcum powder (which is used to lubricate the air bag) or sodium compounds, such as sodium carbonates (e.g. baking soda) that result from the combustion process that inflates the air bag. Small amounts of sodium hydroxide may be present which may irritate the skin and eyes, but none of the residue is toxic. The Air Bag Supplemental Restraint System will reduce, but not eliminate all injuries in an accident.

| |
|-------------------------------------------------------------------------------------------------------------|
|  WARNING |
| Several air bag system components get hot after inflation. Do not try to touch them after inflation. |



⚠ WARNING

The air bag will inflate only once. The system is designed to function on a one-time-only basis. If the air bag is inflated, THE AIR BAG WILL NOT FUNCTION AGAIN AND MUST BE REPLACED IMMEDIATELY. If the air bag is not replaced, this will increase the risk of injury in a subsequent collision.

The Air Bag Supplemental Restraint System consists of:

- driver and passenger air bag modules (which include the inflators and air bags),
- one or more impact and safing sensors,
- a system diagnostic module,
- a readiness light and tone,

and the electrical wiring which connects the components.

The diagnostic module monitors its own internal circuits and the supplemental air bag electrical system readiness (including the impact sensors), the system wiring, the air bag system readiness light, the air bag backup power and the air bag igniters.

Determining if System Is Operational

The Air Bag Supplemental Restraint System uses a readiness light and a tone to indicate the condition of the system. The readiness light is in the instrument cluster. When you turn the ignition key to ON, this light will illuminate for approximately six (6) seconds and then turn off. This indicates that the system is operating normally. NOTE: Routine maintenance of the air bag system is not required.

A problem with the system is indicated by one or more of the following:

- the readiness light will either flash or stay lit,
- the readiness light will not light immediately after ignition is turned on,
- a group of five beeps will be heard. The tone pattern will repeat periodically until the problem and light are repaired.

If any of these things happen, even intermittently, have the Air Bag Supplemental Restraint System serviced at your Ford or Lincoln-Mercury dealer immediately. Unless serviced, the system may not function properly in the event of a collision.

Disposal of Air Bags and Air Bag Equipped Vehicles

For disposal of air bags or air bag equipped vehicles, see your local Ford or Lincoln-Mercury dealer. Air bags **MUST BE** disposed of by qualified personnel.

Safety Restraints for Children

In the U.S. and Canada, you are required by law to use safety restraints for children. If small children ride in your vehicle — this generally includes children who are four years old or younger and who weigh 40 pounds (18 kg) or less — you must put them in safety seats that are made specially for children. Safety belts alone do not provide maximum protection for these children. Check your local and state laws for specific requirements.

| |
|-------------------------------------------------------------------------------------------------------------------------------------------------------------|
| ⚠ WARNING |
| Never let a passenger hold a child on his or her lap while the vehicle is moving. The passenger cannot protect the child from injury in a collision. |

| |
|-----------------------------------------------------------------------------------------------------|
| ⚠ WARNING |
| To prevent the risk of injury, make sure children sit where they can be properly restrained. |

⚠️ WARNING

It is extremely dangerous to ride in a cargo area, inside or outside of a vehicle. In a collision, people riding in these areas are more likely to be seriously injured or killed. Do not allow people to ride in any area of your vehicle that is not equipped with seats and safety belts. Be sure everyone in your vehicle is in a seat and using a safety belt properly.

When possible, put children in the rear seat of your vehicle. Accident statistics suggest that children are safer when properly restrained in the rear seating positions than in the front seating positions.

⚠️ WARNING

Carefully follow all of the manufacturer's instructions included with the safety seat you put in your vehicle. If you do not install and use the safety seat properly, the child may be injured in a sudden stop or collision.

⚠️ WARNING

Safety belts and seats can become hot in a vehicle that has been closed up in sunny weather; they could burn a small child. Check seat covers and buckles before you place a child anywhere near them.

⚠️ WARNING

Do not leave children, unreliable adults, or pets unattended in your vehicle.

Safety Seats for Children

Use a safety seat that is recommended for the size and weight of the child. Always follow the safety seat manufacturer's instructions when installing and using the safety seat.

Most child safety seats can be used in this vehicle only in vehicle seating positions with lap/shoulder belts. Any booster-type seat that places the vehicle's lap belt or shoulder belt around a shield above and ahead of the child's hips should not be used in this vehicle. This type of safety seat could cause injury by tipping over the front edge of the vehicle seat during a collision.

| |
|-------------------------------------------------------------------------------------------------------------------------------------------|
|  WARNING |
| The following instructions MUST BE FOLLOWED to reduce risk of injury from a safety seat tipping too far forward in a severe crash. |

Install forward-facing child safety seats only in vehicle seating positions equipped with lap/shoulder belts. Forward-facing convertible safety seats can be used in the center of the three-passenger second row bench seat only if a top tether strap is used. Ford recommends placing forward-facing safety seats in the second row and using safety seats with top tether straps for added protection.

For more information on top tether straps see *Attaching Safety Seats With Tether Straps* in this chapter.

When installing a child safety seat, be sure to use the correct safety belt buckle for that seating position, and make sure the tongue is securely fastened in the buckle. For a shoulder/lap belt combination with a sliding tongue, make sure the retractor is in the automatic locking mode.

All child restraint systems are designed to be secured in vehicle seats by lap belts or by the lap portion of a lap-shoulder belt.

⚠ WARNING

If you do not properly secure the safety seat, the child occupying the seat may be injured during a collision or sudden stop. An unsecured safety seat could also injure other passengers.

⚠ WARNING

Carefully follow all of the manufacturer's instructions included with the safety seat you put in your vehicle. If you do not install and use the safety seat properly, the child may be injured in a sudden stop or collision.

Installing Child Safety Seats in the Front Seat and Rear Outboard Seating Positions

Your vehicle is equipped with a dual locking mode retractor on the shoulder belt portion of the combination lap/shoulder safety belt for the right front seat passenger and rear outboard passengers.

If you choose to install a child safety seat or infant carrier in these seating positions:

1. Position the child seat on the seat of the vehicle. In the front seat, adjust the vehicle seat as far rearward as possible.
2. Pull down on the shoulder belt, then grasp the shoulder belt and lap belt together. See Figure 1.

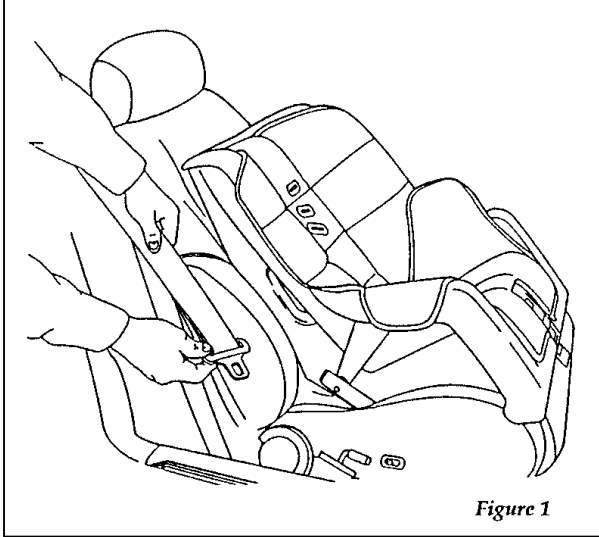

Figure 1

3. While holding the shoulder and lap belt portions together, route the tongue through the child seat according to the child seat manufacturer's instructions. See Figure 2. Be sure the belt webbing is not twisted, and insert the tongue into the buckle. See Figure 3.

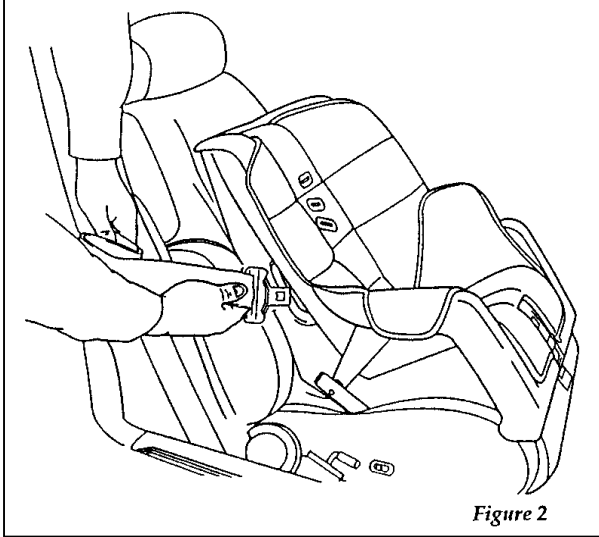

Figure 2

Routing the lap/shoulder belt

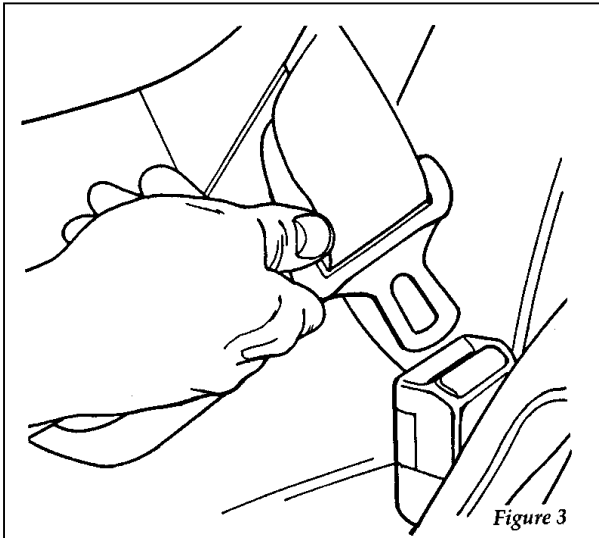
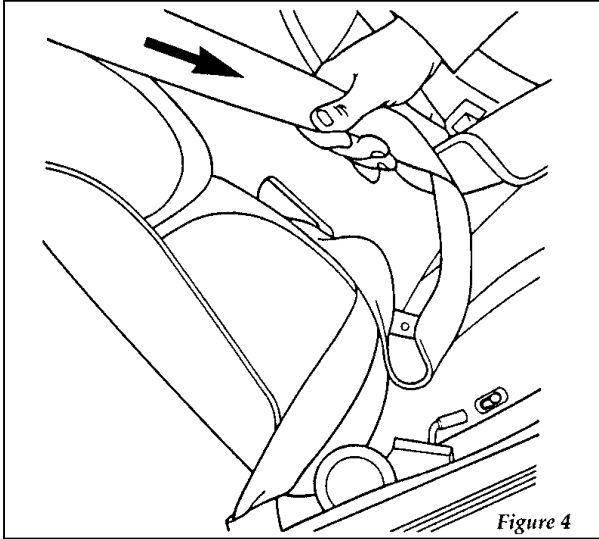

Figure 3

Buckling the belt

4. Grasp the shoulder portion of the belt and pull downward until all of the belt is extracted and a click is heard. At this time, the retractor is in the automatic locking mode (child seat restraint mode). See Figure 4.



Setting the retractor to automatic locking mode

5. Allow the belt to retract. Pull up on the shoulder webbing. A clicking sound will be heard as the belt retracts. This indicates the retractor is in the automatic locking mode. Push down on the child seat while you pull up on the belt to remove any slack in the belt. See Figures 5 and 6.

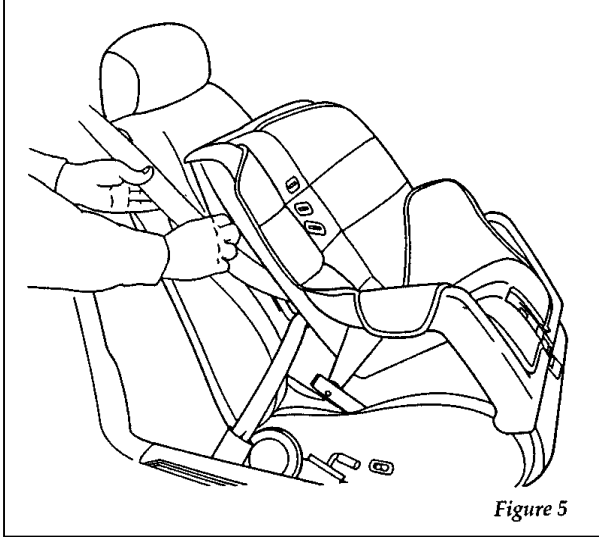
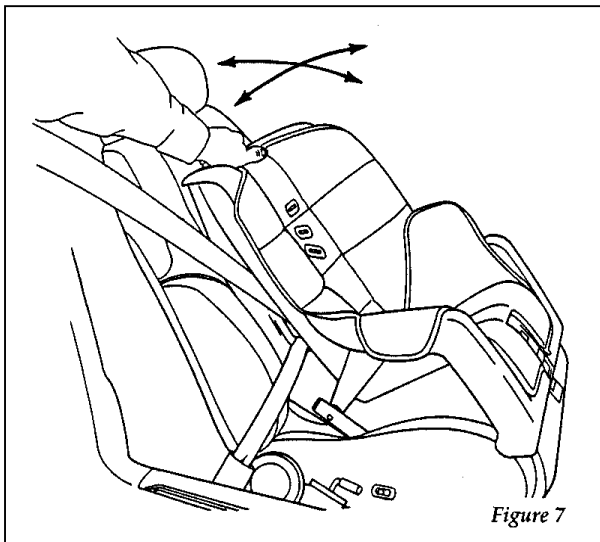

Figure 5



Figure 6

6. Before placing the child in the child seat, forcibly tilt the seat from side to side, and tug it forward to make sure that the seat is securely held in place. See Figure 7.



Checking that the seat is secure

7. Double check that the retractor is in the automatic locking mode. Try to pull more belt out of the retractor. If you cannot, the belt is in the automatic locking mode. See Figure 8.

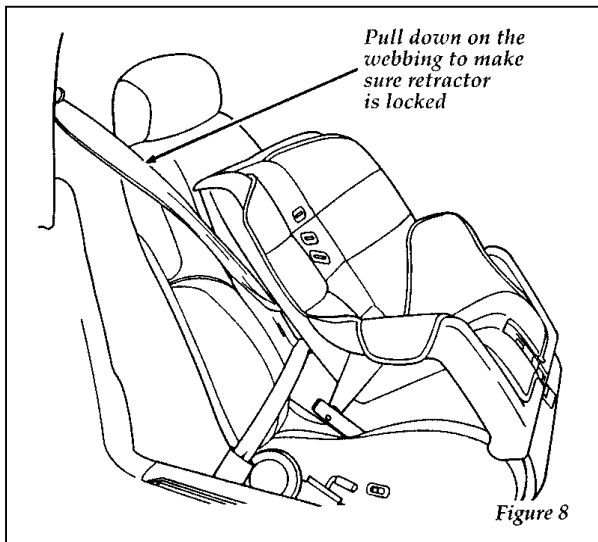

Checking the retractor

8. Check to make sure that the child seat is properly secured prior to each use. If the retractor is not locked, repeat steps 4 through 7.

NOTE: To remove the retractor from automatic lock mode, allow seat belt to retract fully to its stowed position and the retractor will automatically switch back to the vehicle sensitive locking mode for normal adult usage.

⚠ WARNING

Carefully follow all of the manufacturer's instructions included with the safety seat you put in your vehicle. If you do not install and use the safety seat properly, the child may be injured in a sudden stop or collision.

Installing Child Safety Seats at the Rear Center Seating Position with Locking Adjustable Lap Belt

DO NOT install a forward-facing child safety seat in the third row center seating position. Forward-facing seats must be installed with a lap/shoulder belt, or a lap belt and top tether strap.

1. Lengthen the lap belt. To lengthen the belt, hold the tongue so that its bottom is perpendicular to the direction of webbing while sliding the tongue toward the loose end of webbing.
2. Place the child safety seat in the center seating position.
3. Route the tongue and webbing through the child seat according to the child seat manufacturer's instructions.
4. Insert the belt tongue into the proper buckle for the center seating position until you hear a snap and feel it latch. Make sure the tongue is securely fastened to the buckle by pulling on tongue.
5. Push down on the child seat while pulling on the loose end of the lap belt webbing to tighten the belt.
6. Before placing the child into child seat, forcibly tilt the child seat from side-to-side and in forward directions to ensure that the seat is held securely in place. If the child seat moves excessively, repeat steps 5 through 6, or properly install the child seat in a different seating position.

Attaching Safety Seats With Tether Straps

Some manufacturers make safety seats that include a tether strap that goes over the back of the vehicle seat and attaches to an anchoring point. Other manufacturers offer the tether strap as an accessory. Contact the manufacturer of your child safety seat for information about ordering a tether strap.

You can attach a tether strap anchor bracket to the rear floor by using a tether anchor kit (613D74), available at no charge from any Ford dealership.

Read and carefully follow the instructions provided with the kit for installation of the child tether strap anchor.

Ford recommends placement of tethered safety seats in a second row seating position with the tether strap installed to the tether anchoring point as shown in the instructions provided with the child tether strap anchor kit.

| |
|--------------------------------------------------------------------------------------------------|
|  WARNING |
|--------------------------------------------------------------------------------------------------|

| |
|----------------------------------------------------------------------------------------------------------------------------------------------------------------------------|
| <p>Only use the tether attachment hole locations shown in the illustrations. The tether anchor may not perform properly if the wrong mounting location is used.</p> |
|----------------------------------------------------------------------------------------------------------------------------------------------------------------------------|

Four (4) tether strap anchor locations have been provided in your vehicle. If you want your child's safety seat located in the front, right hand passenger seat, you must use the tether strap anchor attachment location under the second row bench seat or right hand bucket seat. For second row seating positions, you must use one of the three (3) tether strap anchor locations under the third row bench seat.

Until a floor anchor is installed, follow these steps to install a tethered child safety seat in the front seat:

1. Buckle the lap/shoulder belt in the seat directly behind the front passenger seat.
2. Pull all the stored belt out of the rear seat belt retractor to switch the retractor to automatic locking mode.
3. Let the retractor wind up the slack from the lap/shoulder belt. A clicking sound should be heard as the belt retracts, indicating that the retractor is in automatic locking mode.
4. Install the child safety seat in the right front seat. Refer to the previous section on *Installing Child Safety Seats*. Hook the tether strap around the webbing near the center of the shoulder portion of the lap/shoulder belt.
5. Tighten the tether strap.

Until floor-mounted tether anchors are installed, tether straps of child safety seats in the second row may be anchored to lap/shoulder belts for the third row, following the five steps above, or to the tongue of the third row lap belt.

⚠️ WARNING

Follow these precautions to decrease the chance of injury in an accident.

⚠️ WARNING

If the anchor bolt(s) is ever removed, the hole(s) in the floor must be sealed to prevent the possibility of exhaust fumes entering the passenger compartment.

Built-In Child Seat (If equipped)

The second row bench seat may include an optional built-in child safety seat. This child restraint is to be used **only** by children who are at least one year old, weigh between 22 and 60 pounds (10 and 27 kilograms) and whose shoulders (top) are below the shoulder harness slots in the seatbacks with the headrest in the full up position.

If your child is less than one year old or weighs less than 10 kilograms (22 pounds), **always** use a rear facing infant or convertible seat because a child of that size is not sufficiently developed to withstand crash forces in a front facing position. Follow the specific manufacturer's instructions for weight and height restrictions.

Children must be properly buckled before riding in the vehicle. It is the law in every state and province. This child seat conforms to all Federal/Canadian motor vehicle safety standards.

Always adjust the lap and shoulder harness belts provided with this child seat snugly around your child.

| |
|--------------------------------------------------------------------------------------|
| ⚠ WARNING |
| Do not leave children, unreliable adults, or pets unattended in your vehicle. |

| |
|---------------------------------------------------------------------------------------------------------------------------------------------------------------------------------------------------------------|
| ⚠ WARNING |
| Safety belts and seats can become hot in a vehicle that has been closed up in sunny weather; they could burn a small child. Check seat covers and buckles before you place a child anywhere near them. |

⚠ WARNING

Failure to follow all of the instructions on the use of this child restraint system can result in your child striking the vehicle's interior during a sudden stop or crash.

How to use the Built-In Child Seat

Read the following procedures and all of the labels on the Built-In Child Seat before using the seat.

⚠ WARNING

Never use the Built-In Child Seat as a booster cushion with the adult safety belts. A child using the adult belts could slide forward and out from under the safety belts.

1. Pull the headrest release strap and grasp the headrest as shown in Figure 1. Then release the strap and rotate the headrest fully until the latch "clicks" in the full up position.

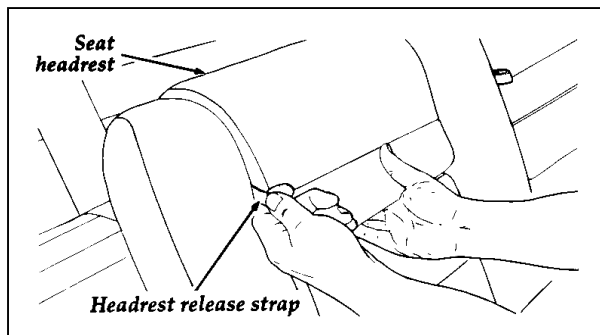

Figure 1

2. Continue to unfold the child seat until it rests on the seat as shown in Figure 2.

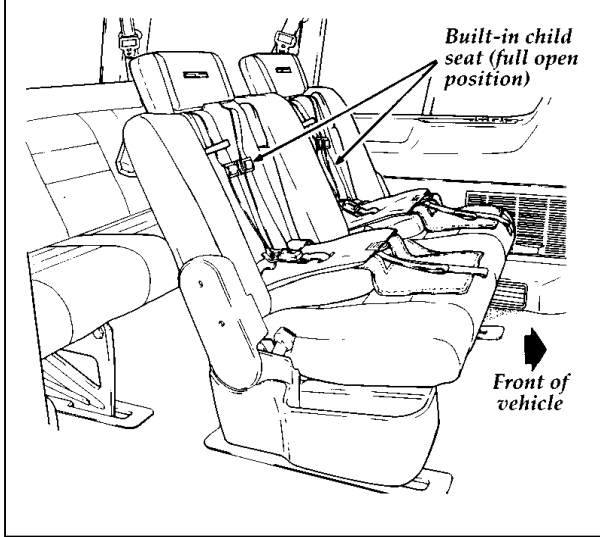

Figure 2

3. Read the information and warnings on the child seat. Check the child's size, weight and age to be sure the child is not too small or too large for the child seat. Refer to Figure 3.

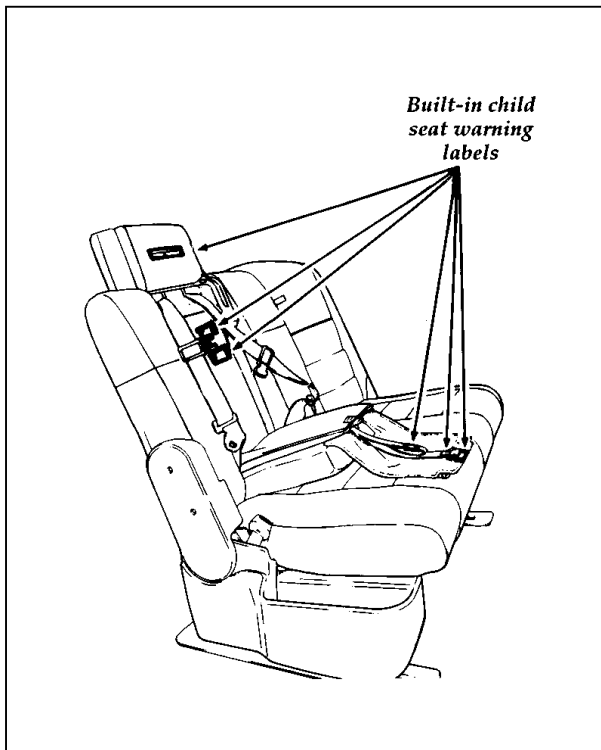

Figure 3

4. Pull up on the two black looped straps at the upper corners of the child seat to unsnap the cushion protector flap.
5. Lower the seat cushion.
6. Pull the lap and shoulder belts cinch release strap while pulling the shoulder belts fully out. Refer to Figures 4 and 5.

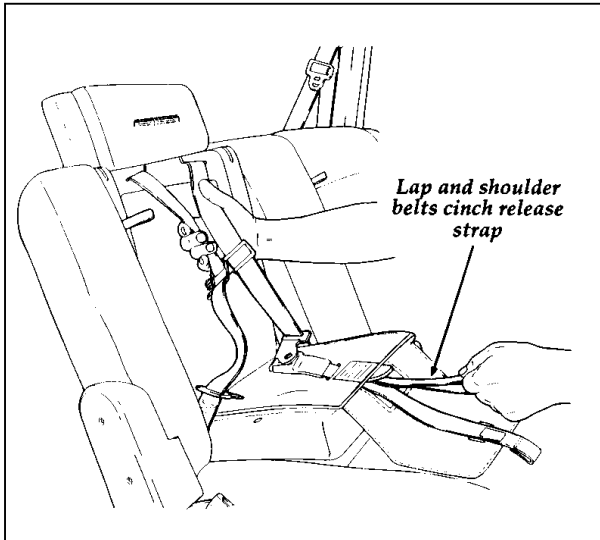

Figure 4

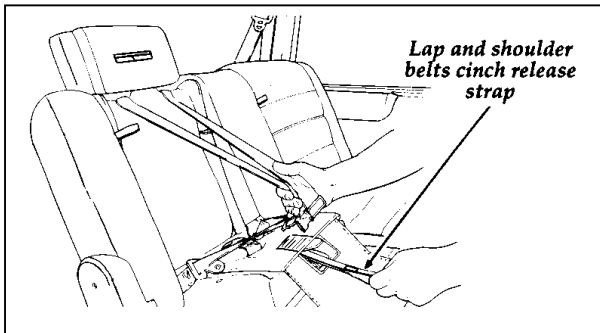

Figure 5

6. If connected, squeeze the top and the bottom of the right half of the chest clip and pull to separate both halves.
7. Place the child on the child seat and position the shoulder belts over each shoulder. Refer to Figure 6.

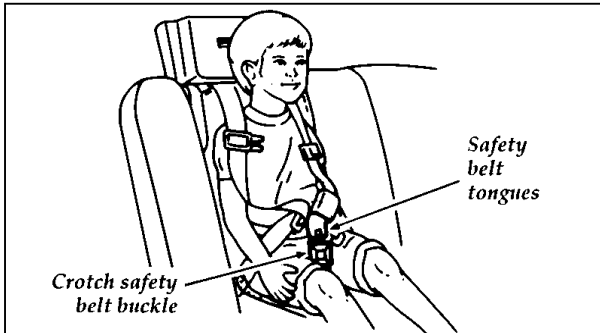

Figure 6: Shoulder safety belt placement on the child

8. Insert either the left or right safety belt tongue into the single opening of the crotch belt buckle as shown in Figure 7. (It does not matter which tongue is inserted first.) Then insert the other tongue.

| |
|------------------------------------------------------------------------------------------------------------|
| ⚠ WARNING |
| If both tongues do not latch in the buckle, do not use the child seat. See your dealer for repairs. |

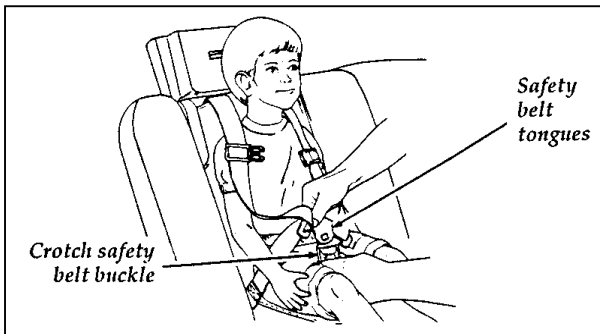

Figure 7: Fastening the crotch safety belt buckle

9. Fasten both halves of the chest clip below the child's shoulders and adjust it to comfortably hold the shoulder belts in place on the child's chest. The purpose of this clip is to position the shoulder belts correctly on the child's shoulders. The clip can be easily pulled apart, and is designed to pull apart during a collision. The clip helps keep the shoulder belts on the shoulders of a sleeping or squirming child. Refer to Figure 8.

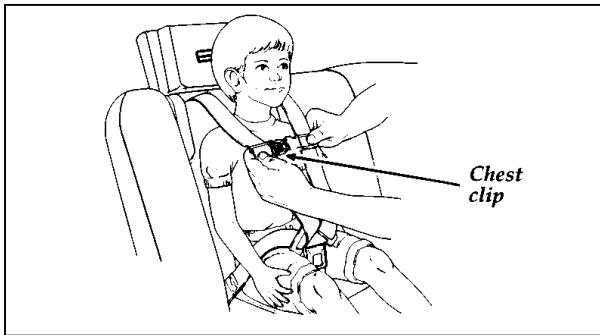

Figure 8: Securing the chest clip

10. Pull the shoulder belts out to ensure that the crotch safety belt buckle is securely fastened. Adjust the lap and shoulder belts by pulling firmly on the adjustment belt. Refer to Figure 9.

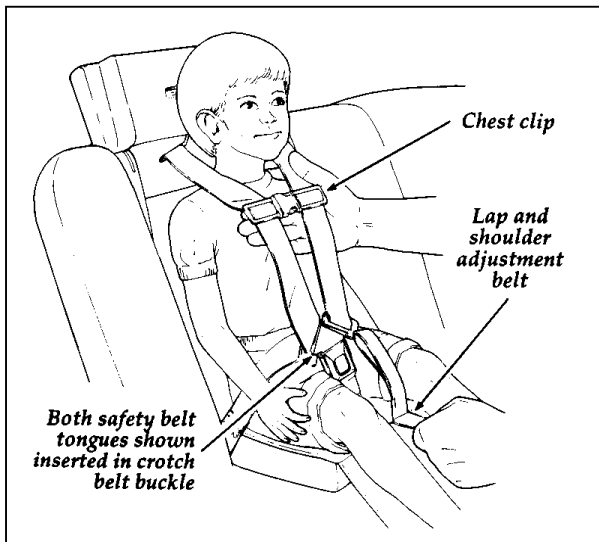

Figure 9: Checking for securely latched buckle and locked retractor

11. If the shoulder belts are pulled too tight, pull on the lap and shoulder belts cinch release strap to loosen the shoulder belts on the child's shoulders. Refer to Figure 4. Then retighten the lap and shoulder adjustment belt per Step 10 above.

To remove the child from the built-in child seat:

1. Squeeze the tabs on the top and bottom of the chest clip and pull the halves apart to open the chest clip. Refer to Figure 8.
2. Press the release button on the crotch safety belt buckle.
3. Slide the shoulder belts off the child's shoulders and remove the child. Refer to Figure 6.

To stow the built-in child seat:

1. Return the child seat cushion to the upright position and lift the protector flap toward the headrest.
2. Fasten the snaps securely.
3. Pull on the headrest release strap and rotate the headrest downward until it latches against the child seat cushion.

⚠ WARNING

Always fasten the protector flap snaps when stowing your child seats to prevent the child seat cushion from rotating forward in a collision.

The seat can now be used by an adult.

Inspection after a collision

⚠ WARNING

All built-in child restraints, including seats, buckles, retractors, seat latches, interlocks, and attaching hardware should be inspected by a qualified dealer technician after any collision.

If the child seat was in use during a collision, Ford recommends replacing it. However, if the collision was minor and a qualified technician finds that the child restraints do not show damage and continue to operate properly, they do not need to be replaced. If there is any bending of the vehicle seatback or seat structure, it should also be replaced. Built-in child seats not in use during a collision should also be inspected and replaced if either damage or improper operation is noted.

Built-in child seat maintenance

Regularly inspect the lap and shoulder belts system of your child seat. See your Ford dealer if the shoulder belt webbing is frayed, or if the buckle and tongue are damaged and/or do not function properly.

Safety Belts for Children

Children who are too large for child safety seats should always wear safety belts. (See instructions with your child seat, or contact its manufacturer, to determine maximum size of child that will safely fit in the seat.)

| |
|------------------------------------------------------------------------------------------------------------------------------------------------------|
|  WARNING |
| If safety belts are not properly worn and adjusted as described, the risk of serious injury to the child in a collision will be much greater. |

If the shoulder belt portion of one of the lap and shoulder belts can be positioned so that it does not cross or rest in front of the child's face or neck, the child should wear the lap and shoulder belt. Moving the child closer to the center of the vehicle may help provide a good shoulder belt fit.

To improve the fit of lap and shoulder belts on children who have outgrown child safety seats, Ford recommends use of a belt-positioning booster seat that is labelled as conforming to all Federal motor vehicle safety standards. Belt-positioning booster seats raise the child and provide a shorter, firmer seating cushion that encourages safer seating posture and better fit of lap and shoulder belts on the child. A belt-positioning booster should be used if the shoulder belt rests in front of the child's face or neck, or if the lap belt does not fit snugly on both thighs, or if the thighs are too short to let the child sit all the way back on the seat cushion when the lower legs hang over the edge of the seat cushion. You may wish to discuss the specific needs of your child with your pediatrician.

⚠ WARNING

Do not use a belt-positioning booster with a lap-only belt.

Lap belts and the lap belt portion of lap and shoulder belts should always be worn snugly and below the hips, touching the child's thighs.

⚠ WARNING

Children should always ride with the seatback in the fully upright position.

Starting

Fuel-Injected Engines

When starting a fuel-injected engine, **the most important thing to remember is to avoid pressing down on the accelerator before or during starting.** Only use the accelerator when you have problems getting your vehicle started. See *Starting Your Engine* in this chapter for details about when to use the accelerator while you start your vehicle.

Starting Your Vehicle

Preparing to Start Your Vehicle

| |
|--------------------------------------------------------------------------------------------------|
|  WARNING |
|--------------------------------------------------------------------------------------------------|

| |
|-----------------------------------------------------------------------------------------------------------------------------------------------------------------------------|
| <p>Do not start your vehicle in a closed garage or in other enclosed areas. Exhaust fumes can be toxic. Always open the garage door before you start the engine.</p> |
|-----------------------------------------------------------------------------------------------------------------------------------------------------------------------------|

Before you start your vehicle, do the following:

1. Make sure all occupants in the vehicle buckle their safety belts. See *Safety Restraints* in the Index for more details.
2. Make sure the headlamps and other accessories are turned off when starting.
3. Make sure that the gearshift is in P (Park) and the parking brake is set before you turn the key.

Before you start your vehicle, you should test the warning lights on the instrument panel to make sure that they work. Refer to the *Instrumentation* chapter.

Starting Your Engine

To start your engine:

1. Follow the steps under *Preparing to Start Your Vehicle* at the beginning of this section.
2. Turn the ignition key to the ON position.
3. DO NOT depress the accelerator pedal when starting your engine. DO NOT use the accelerator while the vehicle is parked.
4. Turn the key to the START position (cranking) until the engine starts. Allow the key to return to the ON position after the engine has started.

If you have difficulty in turning the key, rotate the steering wheel slightly because it may be binding.

For a cold engine:

- At temperatures **10°F (-12°C) and below**: If the engine does not start in **fifteen (15) seconds** on the first try, turn the key to OFF, wait approximately ten (10) seconds so you do not flood the engine, then try again.
- At temperatures **above 10°F (-12°C)**: If the engine does not start in **five (5) seconds** on the first try, turn the key to OFF, wait approximately ten (10) seconds so you do not flood the engine, then try again.

For a warm engine:

- Do not hold the key in the START position for more than **five (5) seconds** at a time. If the engine does not start within five (5) seconds on the first try, turn the key to the OFF position. Wait a few seconds after the starter stops, then try again.

Whenever you start your vehicle, release the key as soon as the engine starts. Excessive cranking could damage the starter.

After starting, allow the engine to idle for a few seconds before driving away.

NOTE: Your vehicle is equipped with a brake-shift interlock feature. This feature prevents you from shifting from P (Park) unless you have the brake pedal depressed. (The ignition must be in the ON position.) If you cannot shift from P (Park) with the brake pedal depressed:

1. Apply the parking brake.
2. Remove the key.
3. Insert the key and rotate it one position clockwise (ignition in the OFF position).
4. Apply the brake pedal and shift to N (Neutral). (If the vehicle is shifted back to P [Park], you must repeat the previous steps.)
5. Start the vehicle.

If you need to shift out of P (Park) by using the alternate procedure described above, it is possible that a fuse has blown and that your brakelamps may also not be functional. Please refer to the chapter titled *Roadside Emergencies* in this Owner Guide for instructions on checking and replacing fuses.

 **WARNING**

DO NOT DRIVE YOUR VEHICLE UNTIL YOU VERIFY THAT THE BRAKELAMPS ARE WORKING.

If the engine still does not start after two attempts:

1. Turn the ignition key to the OFF position.
2. Press the accelerator all the way to the floor and hold it.
3. Turn the ignition key to the START position.
4. Release the ignition key when the engine starts.
5. Release the accelerator gradually as the engine speeds up.

If the engine still does not start, the fuel pump shut-off switch may have been activated. For directions on how to reset the switch see *Fuel Pump Shut-Off Switch* in the index.

A computer system controls the engine's idle speed. When you start your vehicle, the engine's idle speed normally runs high. These faster engine speeds will make your vehicle coast slightly faster than its normal idle speed. It should, however, slow down after a short time. If it does not, have the idle speed checked.

If the engine idle speed does not slow down automatically, do not allow your vehicle to idle for more than 10 minutes. Have the vehicle checked.

 **WARNING**

Extended idling at high engine speeds can produce very high temperatures in the engine and exhaust system, creating the risk of fire or other damage.

⚠️ WARNING

Do not park, idle, or drive your vehicle in dry grass or other dry ground cover. The emission system heats up the engine compartment and exhaust system, which can start a fire.

If you consistently start your vehicle in subzero temperatures, use an engine block heater (if your vehicle has this option).

Engine Block Heater (If equipped)

Engine block heaters are strongly recommended if you live in a region where temperatures reach -10°F (-23°C) or below. An engine block heater warms the engine coolant, which improves starting, warms up the engine faster, and allows the heater-defrost system to respond quickly.

⚠️ WARNING

To prevent electrical shock, do not use your heater with ungrounded electrical systems or two-pronged (cheater) adapters.

For best results, plug the heater in at least three hours before you start your vehicle. Using the heater for longer than three hours will not damage the engine, so you can plug it in at night to start your vehicle the following morning.

NOTE: Be sure to disconnect the engine block heater before driving your vehicle.

If the Engine Cranks but Does Not Start or Does Not Start After a Collision

Fuel Pump Shut-Off Switch

If the engine cranks but does not start or does not start even after a small collision, the fuel pump shut-off switch may have been activated. The shut-off switch is a device intended to stop the fuel pump when your vehicle has been involved in a substantial jolt. Refer to the *Roadside Emergencies* chapter.

Once the shut-off switch is activated, you must reset the switch by hand before you can start your vehicle.

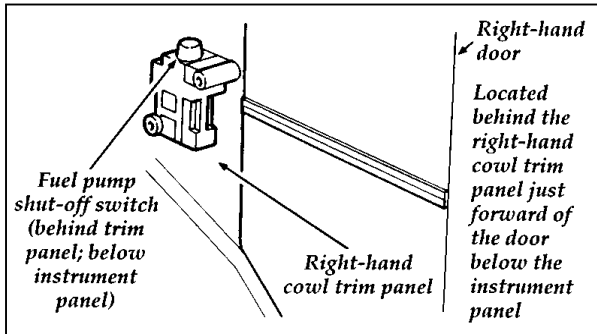

Fuel pump shut-off switch location

! WARNING

If you see or smell fuel, do not reset the switch or try to start your vehicle. Have all the passengers get out of the vehicle and call the local fire department or a towing service.

If your engine cranks but does not start after a collision or substantial jolt:

1. Turn the ignition key to the OFF position.
2. Check under the vehicle for leaking fuel.
3. If you do not see or smell fuel, push the red reset button down. If the button is already set, you may have a different mechanical problem.
4. Turn the ignition key to the ON position for a few seconds, then turn it to the OFF position.
5. Check under the vehicle again for leaking fuel. **If you see or smell fuel, do not start your vehicle again.** If you do not see or smell fuel, you can try to start your vehicle again.
6. Check all vehicle warning lights before driving the vehicle.

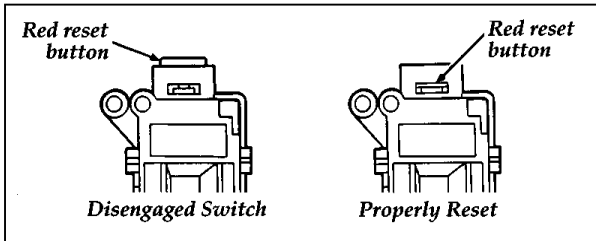

Reset button for fuel pump shut-off switch

⚠️ WARNING

Do not start your vehicle in a closed garage or in other enclosed areas. Exhaust fumes can be toxic. Always open the garage door before you start the engine.

Guarding Against Exhaust Fumes

Carbon monoxide, although colorless and odorless, is present in exhaust fumes. Take precautions to avoid its dangerous effects.

| |
|--------------------------------------------------------------------------------------------------|
|  WARNING |
|--------------------------------------------------------------------------------------------------|

| |
|-----------------------------------------------------------------------------------------------------------------------------------------------------------|
| <p>If you smell exhaust fumes inside your vehicle, have your dealer inspect your vehicle immediately. Do not drive if you smell exhaust fumes.</p> |
|-----------------------------------------------------------------------------------------------------------------------------------------------------------|

If your vehicle has rear windows and doors that were installed as part of a van conversion, close them while it is running. This prevents exhaust fumes from being drawn into the passenger compartment.

Have the exhaust and body ventilation systems checked whenever:

- your vehicle is raised for service
- the sound of the exhaust system changes
- your vehicle has been damaged in a collision

Improve your ventilation by keeping all air inlet vents clear of snow, leaves, and other debris.

If the engine is idling while you are stopped in an open area for long periods of time, open the windows at least one inch (2.5 cm). Also, adjust the heating or air conditioning system to bring in outside air.

- HEATING** — Set fan speed at **MEDIUM** or **HIGH**, the function selector knob on **VENT**, **FLOOR**, **MIX**, or the **DEFROST** symbol and the temperature control knob on any desired position.

- AIR CONDITIONING** — Set the fan speed knob at **MEDIUM** or **HIGH**, the function selector knob on **NORM A/C** or **MAX A/C** and the temperature control knob on any desired position.

Removing the Key From the Ignition

1. Put the gearshift in P (Park).
2. Set the parking brake fully before removing your foot from the service brake. (This will avoid “binding” or “loading” the park gear if you park on a grade.)
3. Turn the ignition key to **LOCK**.
4. Remove the key.

| |
|--------------------------------------------------------------------------------------------------|
|  WARNING |
|--------------------------------------------------------------------------------------------------|

| |
|------------------------------------------------------------------------------------------------------------------------------------------------------|
| Always set the parking brake fully and make sure the gearshift is latched in P (Park). Turn off the ignition whenever you leave your vehicle. |
|------------------------------------------------------------------------------------------------------------------------------------------------------|

| |
|--------------------------------------------------------------------------------------------------|
|  WARNING |
|--------------------------------------------------------------------------------------------------|

| |
|--------------------------------------------------------------------------------------|
| Do not leave children, unreliable adults, or pets unattended in your vehicle. |
|--------------------------------------------------------------------------------------|

Driving

Brakes

Front Disc Brakes

The front disc brakes are self-adjusting. They do not require service other than periodic inspection for pad wear.

Rear Drum Brakes

The rear drum brakes are self-adjusting. Automatic adjustment occurs when the brakes are applied while “backing up.” If normal operation does not include much backing, adjust the brakes when they seem “low,” using the procedure under *If Brakes Do Not Grip Well or Pedal is “Low”* in this chapter.

Hydraulic Power Brakes

The hydraulic brake system is made up of two independent hydraulic circuits. One hydraulic circuit supplies fluid to the front disc brakes and the other hydraulic circuit supplies fluid to the rear drum brakes. These two circuits are supplied by a common hydraulic brake fluid reservoir, with a fluid level sensor.

The brake light in the instrument cluster will light for low brake fluid in the common brake fluid reservoir.

| |
|-------------------------------------------------------------------------------------------------------------------------------|
|  WARNING |
| An increase in pedal travel will result in reduced braking capability. The brake system should be checked immediately. |

Rear Anti-lock Brakes

Your vehicle is equipped with a rear Anti-lock Brake System (ABS). This system prevents at least one and often both rear wheels from completely locking up when the brakes are applied in a panic stop, for example.

Even with the Anti-lock Brake System, you should be careful when braking. Front brake lock up on any surface, even on smooth pavement causes loss of steering control. Heavy braking on roads with loose surfaces such as snow or gravel, or severe pavement irregularities could also cause you to lose steering control of your vehicle.

| |
|---------------------------------------------------------------------------------------------------------------------------------------------------------------------------------|
|  WARNING |
| If the anti-lock brake system warning light remains on or comes on while driving, have the braking system checked by a qualified service technician as soon as possible. |

NOTE: If a fault occurs in the anti-lock system, and the brake warning light is not lit, the anti-lock system is disabled but normal brake function remains operational.

If Brakes Do Not Grip Well or Pedal is “Low”

If brakes do not grip well, it may indicate the rear drum brakes need adjustment. To do this, drive the vehicle in reverse at 5 mph (8 km/h) on level, dry pavement. Stop the vehicle by firmly applying the brakes. Repeat this procedure four or five times.

If during normal operation the brake pedal seems “low”, it may indicate the need for a brake system inspection and/or service. You should have your brakes checked as soon as possible.

Occasional brake squeal during light to moderate stops does not affect the function of the brake system and is normal. However, if the squeal becomes louder or more frequent, have your brakes inspected by your dealer or a qualified service technician.

⚠ WARNING

Modifications to the suspension spring rates and/or vehicle ride height may adversely affect vehicle stopping ability.

If Brakes Pull

- Check tire pressure.
- Perform the self-adjustment procedure described under *If Brakes Do Not Grip Well or Pedal is “Low.”*

If pull occurs during the first 500 miles (800 km), make 10 moderately fast stops from 40 mph (65 km/h) and then perform the self-adjustment procedure above. It may be necessary to repeat this operation to properly seat new brake linings and pads.

Stopping Distances

Stopping distances vary with different loads and driving conditions. Use caution when encountering new conditions and acquaint yourself with vehicle performance. Take full advantage of engine braking power when slowing down.

Applying the Brakes

Apply the brake pedal gradually. Use the “squeeze” technique — push on the brake pedal with a steadily increasing force. This allows the wheels to continue to roll while you are slowing down, which lets you steer properly.

NOTE: If you are driving down a long or steep hill, shift to a lower gear and do not apply your brakes continuously. If you apply your brakes continuously, they may overheat and become less effective.

Parking Brake

The parking brake should be used whenever you park your vehicle.

The parking brake is a hand operated lever located on the floor of your van just to the right of the driver’s seat.

To set the parking brake while parking your van, press the brake pedal with your right foot and hold it while you fully apply the parking brake lever.

To release the parking brake, press the brake pedal with your right foot, depress the release button in the parking brake lever while pulling up on the lever, and then lower the lever all the way to the floor.

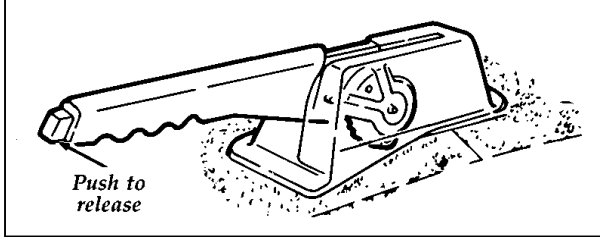

Parking Brake

⚠ WARNING

Always set the parking brake fully and make sure the gearshift is latched in P (Park). Turn off the ignition whenever you leave your vehicle.

⚠ WARNING

If the parking brake is fully released, but the Brake System light remains on, have the brakes checked immediately. They may not be working properly.

The parking brake is not designed to stop a moving vehicle, but you can use the parking brake to stop your vehicle in an emergency if the normal brakes fail. However, since the parking brake applies only the rear brakes, the stopping distance will increase greatly and the handling of your vehicle will be adversely affected.

Steering Your Vehicle

Your vehicle comes with power steering. Power steering uses energy from the engine to help steer your vehicle.

If the amount of effort needed to steer your vehicle changes at a constant vehicle speed, have the power steering system checked. If the power steering system breaks down (or if the engine is turned off), you can steer the vehicle manually but it takes more effort.

Never hold the steering wheel to the extreme right or left for more than five seconds if the engine is running. This can damage the power steering pump.

NOTE: After any severe impact such as striking large potholes, sliding into curbs on icy roads, or a collision involving the front end, observe the steering wheel alignment. If the spokes of the steering wheel seem to be in a different position while going straight down the road, have the front suspension and steering checked for possible damage.

Automatic Transmission Operation (4R44E/5R55E)

If your vehicle is equipped with an automatic transmission, it will be either a four speed overdrive transmission (4R44E) or a five speed overdrive transmission (5R55E). All 3.0L engines use the 4R44E transmission, while all 4.0L engines use the 5R55E transmission. Both transmission types have a lockup torque converter. Transmission operation is controlled by the Powertrain Control Module (PCM).

The PCM will automatically adjust transmission operation to make up for varying conditions. Several sensors located on the engine and transmission such as throttle position, engine speed, vehicle speed and transmission temperature are used by the PCM to shift the transmission into a higher or lower gear when required for the best performance and fuel economy. For example, you may notice that the transmission will upshift to a higher gear more quickly when the vehicle has not reached normal operating temperature.

The PCM also controls the transmission's Torque Converter Clutch (TCC) to further raise vehicle performance and fuel economy. The TCC will engage when the transmission operating temperature and other conditions determined by the PCM have been met. Engagement of the clutch may be noted as a decrease in engine speed.

To help in troubleshooting, the PCM continually performs self-tests on the electronic control system and, if any faults are detected, stores them in memory. The Transmission Control Indicator Light (TCIL) (O/D OFF), which is located on the gearshift lever, may flash steadily if a malfunction has been detected. If the TCIL is flashing, contact your Ford dealer as soon as possible. If this condition persists, damage to the transmission could occur.

Speed limiter

All models are equipped with a Powertrain Control Module (PCM) which limits the maximum engine speed and thus road speed in top gear. Vehicle operation is normal since the controlled maximum speed is above posted highway speeds in North America.

Power Braking

Increasing the engine speed above idle without vehicle movement (such as holding the brake) in a forward or reverse gear causes transmission stall.

NOTE: Continued operation in the stall condition can result in transmission overheating, malfunction or fluid expulsion.

Automatic Overdrive Transmission

Putting Your Vehicle in Gear

Your vehicle's gearshift is on the steering column. The transmission control switch is located on the end of the gearshift lever. You can put the gearshift in any one of several positions.

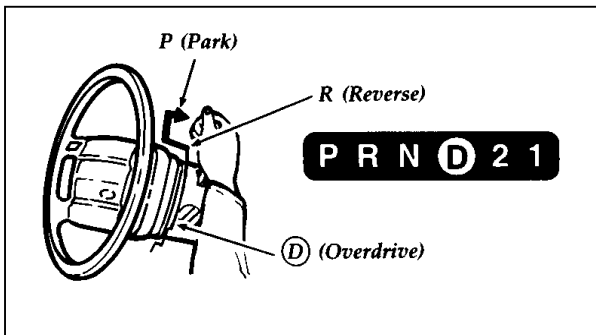

The positions of the column-mounted gearshift

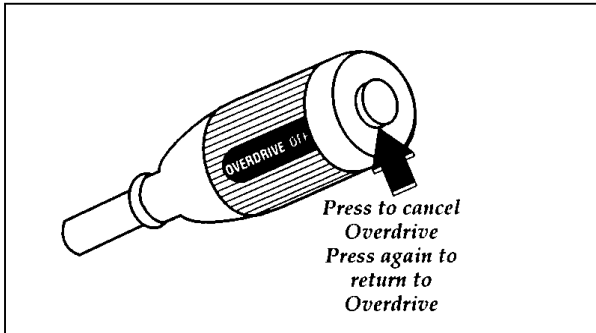

⚠ WARNING

Hold the brake pedal down while you move the gearshift lever from position to position. If you do not hold the brake pedal down, your vehicle may move unexpectedly and injure someone.

Once you place the gearshift securely into position, gradually release the brake pedal and use the accelerator as necessary.

NOTE: Your vehicle is equipped with a brake-shift interlock feature. This feature prevents you from shifting from P (Park) unless you have the brake pedal depressed. (The ignition must be in the ON position.) If you cannot shift from P (Park) with the brake pedal depressed:

1. Apply the parking brake.
2. Remove the key.
3. Insert the key and rotate it one position clockwise (ignition in the OFF position).

4. Apply the brake pedal and shift to N (Neutral). (If the vehicle is shifted back to P [Park], you must repeat the previous steps.)
5. Start the vehicle.

If you need to shift out of P (Park) by using the alternate procedure described above, it is possible that a fuse has blown and that your brakelamps may also not be functional. Please refer to the chapter titled *Roadside Emergencies* in this Owner Guide for instructions on checking and replacing fuses.

| |
|------------------------------------------------------------------------------------|
| ⚠ WARNING |
| DO NOT DRIVE YOUR VEHICLE UNTIL YOU VERIFY THAT THE BRAKELAMPS ARE WORKING. |

P (Park)

Always come to a complete stop before you shift into P (Park). This position locks the transmission and prevents the rear wheels from turning.

To securely latch the gearshift in the P (Park) position, pull it toward you, push it completely counterclockwise against the stop, and then push it toward the instrument panel.

The gearshift is securely latched in P (Park) if you cannot rotate it in a clockwise direction without lifting it toward you.

| |
|------------------------------------------------------------------------------------------------------------------------------------------------------|
| ⚠ WARNING |
| Always set the parking brake fully and make sure the gearshift is latched in P (Park). Turn off the ignition whenever you leave your vehicle. |

⚠ WARNING

Never leave your vehicle unattended while it is running.

R (Reverse)

With the gearshift in the R (Reverse) position, the vehicle will move backward. You should always come to a complete stop before shifting into or out of R (Reverse).

N (Neutral)

With the gearshift in the N (Neutral) position, the vehicle can be started and is free to roll. Hold the brake pedal down while in this position.

⚠ WARNING

Do not leave the vehicle unattended with the transfer case in the N (Neutral) position. Always set the parking brake fully and turn off the ignition when leaving the vehicle.

With the transfer case in N (Neutral), the vehicle is free to move with either the automatic transmission in P (Park) or with the manual transmission in any driving gear.

Driving (4R44E Transmission)

When to use **D (Overdrive)**

This is the normal driving position. As the vehicle picks up speed, automatic upshifts to second, third and fourth gears will occur when **D** Overdrive is chosen on the selector and the transmission control switch has not been pressed. The transmission will shift into the correct gear when the right speed is achieved, for the accelerator pedal position you have chosen.

When to use Drive

You will note there is not a drive position on your gearshift indicator. However, you will find a transmission control switch labeled OVERDRIVE OFF located on the end of the gearshift lever. Press this switch and the indicator light (OFF) illuminates on the gearshift lever. With overdrive cancelled and the OVERDRIVE OFF illuminated, the transmission will operate in gears one through three. This is useful if you experience frequent downshift/upshift conditions, when operating with a heavy load or in hilly terrain, or if additional engine braking is useful. However, shift back to **D** (Overdrive) whenever practical for optimum powertrain cooling and fuel economy. This can be accomplished by pushing the transmission control switch again, to cancel the OVERDRIVE OFF control and light.

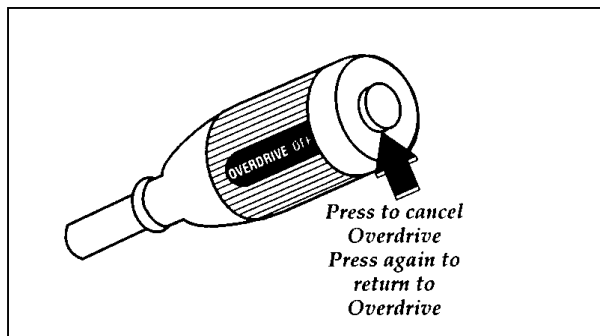

When starting your vehicle, the overdrive system will automatically be in the normal overdrive mode.

When to use 2 (Second)

Use 2 (Second) to start-up on slippery roads or to provide additional engine braking on downgrades. This position provides 2 (Second) gear operation only.

When to use 1 (Low)

Use 1 (Low) to provide maximum engine braking on steep downgrades. Upshifts from 1 (Low) can be made by manually shifting to 2 (Second) or **D** (Overdrive). Selection of 1 (Low) gear provides only low gear operation from start-up. Selection of 1 (Low) while at higher speeds provides a shift to second gear, and a shift to first gear will occur after the vehicle decelerates to the proper speed.

Forced Downshifts

To gain acceleration in **D** (Overdrive) or Drive (**D** position with Overdrive cancelled) when passing another vehicle, push the accelerator to the floor. The transmission will downshift to the appropriate gear: third, second or first.

Driving (5R55E Transmission)

When to use **D** (Overdrive)

This is the normal driving position. As the vehicle picks up speed, automatic upshifts to second, third, fourth and fifth gears will occur when **D** (Overdrive) is chosen on the selector and the transmission control switch has not been pressed. The transmission will shift into the correct gear when the right speed is achieved, for the accelerator pedal position you have chosen.

When to use Drive

You will note there is not a drive position on your gearshift indicator. However, you will find a transmission control switch labeled OVERDRIVE OFF located on the end of the gearshift lever. With overdrive canceled and the OVERDRIVE OFF illuminated, the transmission will operate in gears one through four. This is useful if you experience frequent downshift/upshift conditions, when operating a heavy load or in hilly terrain, or if additional engine braking is useful. However, shift back to **D** (Overdrive) whenever practical for optimum powertrain cooling and fuel economy. This can be accomplished by pushing the transmission control switch again, to cancel the OVERDRIVE OFF control and light.

When to use 2 (Second)

With the gearshift in the 2 (Second) position, more engine braking is provided. Use the 2 (Second) position to drive up moderately steep grades, to start up slippery roads, or to provide moderate engine braking on downgrades. **DO NOT GO FASTER THAN 55 mph (88 km/h) IN THIS GEARSHIFT POSITION.**

When to use 1 (Low)

With the gearshift in the 1 (First) position, maximum engine braking is provided. This position provides 1 (First) gear operation only with no automatic upshifts. To obtain upshifts, the gearshift must be moved out of this position. Use the 1 (First) position to drive up steep grades or to provide maximum engine braking on downgrades.

Forced Downshifts

To gain acceleration in **D** (Overdrive) or Drive (Overdrive off) when passing another vehicle, push the accelerator to the floor. The transmission will downshift to the appropriate gear: fourth, third, second or first gear.

Traction-Lok Rear Axle (If equipped)

This axle provides added drive away traction on slippery surfaces, particularly when one or more wheels are on a surface with poor traction.

Extended use of other than matching size tires on a Traction-Lok rear axle could result in a permanent reduction in effectiveness. This loss of effectiveness does not affect normal driving and should not be noticeable to the driver.

Electronic 4-Wheel Drive (E-4WD) (If equipped)

If your vehicle is equipped with the E-4WD option, power is provided to all four wheels whenever you press the accelerator pedal. It improves both handling and traction during difficult driving conditions, adjusting automatically to your driving needs. Because the entire E-4WD system is controlled by a microprocessor, your vehicle is not equipped with the switch or shift lever used with most traditional 4WD vehicles. The microprocessor does all the adjusting for you.

How the Electronic 4-Wheel Drive (E-4WD) System Works

Under normal driving conditions, when the road is firm, dry and level, the engine power is distributed one-third to the front axle and two-thirds to the rear axle. However, if a wheel begins to slip, the microprocessor will sense this condition and signal the system to transmit more power to the axle with more traction. (You may feel a momentary surge of power.)

NOTE: The microprocessor is disabled when the brakes are applied or when the transmission selector is in the P (Park) or N (Neutral) positions.

Driving Your Electronic 4-Wheel Drive (E-4WD) Vehicle

Since your E-4WD vehicle is unique, follow these steps to be safe:

- Avoid unnecessary turns or other maneuvers that could cause loss of control and possible injury.
- Use the same size and type of tire and wheel as originally provided for your vehicle and inflate the tires to the manufacturer's recommended air pressure.
- Become familiar with your vehicle's operating characteristics and study this Owner Guide for specific operating instructions. Be sure all occupants wear the safety belts provided. Drive cautiously, defensively, and at speeds safe for current road conditions.

- ❑ Do not let the added driving traction of E-4WD lead you to believe that you can stop any quicker than a conventional two-wheel drive vehicle. The added traction performance does not improve the braking ability of the E-4WD vehicle. Allow the same amount of distance when braking as with a two-wheel drive vehicle.

⚠ WARNING

Your E-4WD Aerostar is a passenger vehicle designed for on-road use; it is not intended for any off-road use.

⚠ WARNING

On-vehicle wheel balancing will cause damage to the drivetrain of E-4WD Aerostars.

Driving With a Heavy Load

There are limits to the amount of weight your vehicle can carry or tow. The total weight of your vehicle, plus the weight of the passengers and cargo, should never be more than the Gross Vehicle Weight Rating (GVWR). Also, the weight that your vehicle carries over the front axle and rear axle should never be more than the Gross Axle Weight Rating (GAWR) for the respective axle.

The weight limits of your vehicle's tires affect the GVWR or GAWR limitations. Usage of replacement tires with higher weight limits than originals does not increase GVWR or GAWR. Usage of lower capacity replacement tires may lower GVWR and GAWR limitations.

⚠ WARNING

Do not exceed the GVWR or the GAWR specified on the Safety Compliance Certification Label.

Vehicle/Trailer Loads

All vehicles may tow a Class I trailer provided the Gross Combined Weight (GCW) is less than or equal to the GVWR shown on the Safety Compliance Certification Label. For heavier trailer applications, refer to the towing information found later in this chapter.

Towing a trailer puts additional loads on your vehicle's engine, transmission, axle, brakes, tires and suspension. For your safety and for the good of your vehicle, use the right equipment for the type of trailer you tow.

Your trailer towing capability will vary based on the standard and optional equipment on your vehicle. Refer to the following *Vehicle Loading/Towing Information* and the Trailer Towing Tables to determine the specific towing capability of your vehicle.

- Stay within the load limits when you tow.
- Carefully and thoroughly prepare your vehicle for towing, making sure to use the right equipment and to attach it properly. (See *Preparing to Tow* in this chapter.)
- Use extra caution when driving your vehicle while you tow. (See *Driving while you tow* in this chapter.)
- Service your vehicle more frequently if you tow a trailer. (See *Servicing your vehicle if you tow* in this chapter.)

Standard length vehicles adapted for trailer tow may require relocation of the underbody spare tire. It is recommended that you secure the tire under the rear-most seat using the hold-down hardware located with the jack.

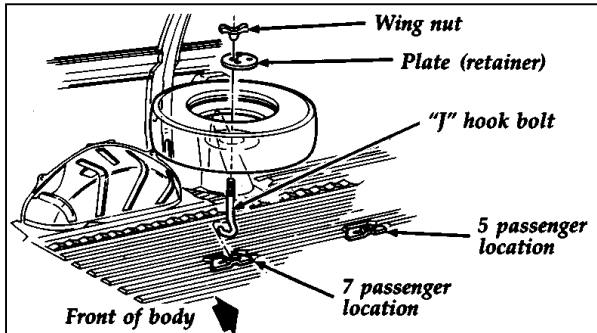

Spare tire stowage (standard length model)

Do not tow a trailer until your vehicle has been driven at least 500 miles (800 km).

Vehicle Loading/Towing Information

Your vehicle's load capacity is designated by weight, not volume, so you cannot necessarily use all available space with large or heavy loads. Maximum safe vehicle weights as well as tire, rim sizes and inflation pressures are specified for your vehicle at the assembly plant on the Safety Compliance Certification Label. The Certification Label is located on the left front door lock facing or the door latch post pillar.

Trucks, unlike passenger cars, are basically custom vehicles designed to carry a load. Most owners start with a base vehicle and add production and dealer installed and/or aftermarket components to suit their tastes and purposes. Even trucks that are purchased for personal transportation only are likely to have considerable optional equipment, such as step bumpers and light bars, for example.

⚠️ WARNING

It is extremely dangerous to ride in a cargo area, inside or outside of a vehicle. In a collision, people riding in these areas are more likely to be seriously injured or killed. Do not allow people to ride in any area of your vehicle that is not equipped with seats and safety belts. Be sure everyone in your vehicle is in a seat and using a safety belt properly.

⚠️ WARNING

Cargo should always be secured to prevent it from shifting and causing damage to the vehicle or harm to passengers.

Each additional item of equipment affects how much cargo a vehicle can carry. If a vehicle is overloaded, performance will suffer and service concerns may arise.

The following is a typical example of a Safety Compliance Certification Label and an explanation of how this information should be used:

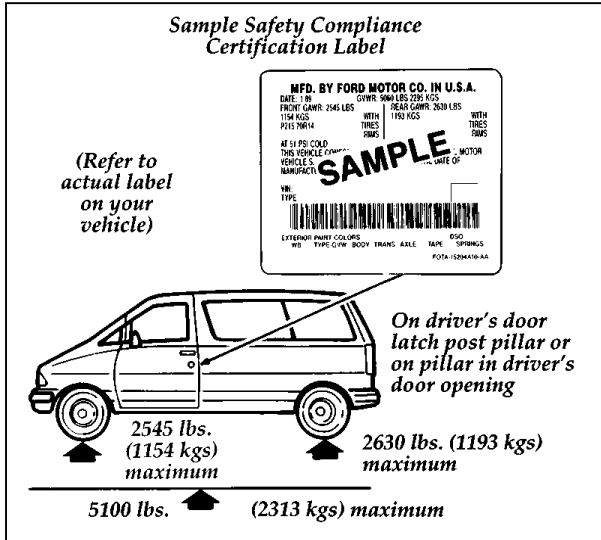

Safety Compliance Certification Label

Do not use the sample numbers on the Safety Compliance Certification Label shown. Use the actual numbers from your vehicle certification label.

Understanding Loading/Towing Information

The following terms are used to describe the ability to carry or tow a load:

- Base Curb Weight
- Payload
- GVW (Gross Vehicle Weight)
- GVWR (Gross Vehicle Weight Rating)

- GAWR (Gross Axle Weight Rating)
- GAWR F (Gross Axle Weight Rating Front)
- GAWR R (Gross Axle Weight Rating Rear)
- GCWR (Gross Combined Weight Rating)
- Maximum Trailer Weight Rating
- Maximum Trailer Weight
- Trailer Weight Range

Base Curb Weight

The Base Curb Weight is the weight of the vehicle including fuel, coolants, lubricants, emergency tools, spare wheel and tire. It also includes any equipment that is *standard* on that model. It does not include passengers, cargo or optional equipment installed by factory, dealer, aftermarket supplier or customer.

Payload

Payload is the combined, maximum allowable weight of cargo, occupants and optional equipment that the truck is designed to carry. It is Gross Vehicle Weight Rating minus the base curb weight.

Gross Vehicle Weight (GVW)

It is important to remember that GVW *is not a limit or a specification*. If an owner loads up a vehicle and weighs it, that's the GVW at that moment. If the owner piles on more of a load and weighs it again, that becomes the GVW.

Gross Vehicle Weight Rating (GVWR)

To avoid overloading a vehicle, the owner should observe the manufacturer's specified Gross Vehicle Weight Rating. The GVWR is the maximum total weight of base vehicle, passengers, optional components and cargo that a particular vehicle was designed to carry.

Gross Axle Weight Rating (GAWR)

We have all seen a car or a truck that is loaded down in the rear and riding high in the front. This is a dangerous condition that usually means that the rear suspension components are under severe strain and that vehicle handling is impaired. There is more to carrying a load than just payload or GVWR.

Your Safety Compliance Certification Label not only gives the GVWR, it also gives the Gross Axle Weight Rating (GAWR) which is the carrying capacity for each axle system. For trucks, the rear axle will be designed to carry more weight than the front.

The rating is based on the carrying capacity of the *lowest rated* axle and suspension component as well as other factors. This is why it's so important to observe vehicle loading ratings. Overloading a vehicle punishes components and can lead to shortened service life or outright failure.

The capacity of the tires is included as part of the axle and suspension system, which is to be considered when determining the lowest rated component. Tires are rated to carry a specific maximum load at a specific maximum tire pressure.

Passenger car type tires when installed on light trucks and multipurpose passenger vehicles are rated at 10% lower load carrying capacity due to the differences in vehicle usages.

The vehicle must not be loaded to both the front and rear GAWR because the GVWR will be exceeded. The GAWR of the front and rear axles exceeds the GVWR when added together to allow flexibility in fore and aft loading of cargo.

With the tires inflated to the specified pressure, the total weight of your vehicle must not exceed the GVWR and GAWR specified on the Safety Compliance Certification Label. This includes full fuel tank(s), vehicle equipment, and occupants as well as the cargo load.

GCWR (Gross Combined Weight Rating)

GCWR is the maximum combined weight of the towing vehicle (including passengers and cargo) and the loaded trailer. The GCWR is specified by the manufacturer to indicate the combined maximum loaded weight that the vehicle is designed to tow.

Maximum Trailer Weight Rating

The maximum trailer weight rating is the maximum weight of a trailer the vehicle is permitted to tow. It is specified by the manufacturer and is determined by subtracting the vehicle curb weight for each engine/transmission combination, any required option weight for trailer towing and the weight of the driver from the GCWR for the towing vehicle.

Maximum Trailer Weight

The maximum trailer weight is the maximum weight of a trailer the loaded vehicle is permitted to tow. It is determined by subtracting the weight of the loaded towing vehicle (including passengers and cargo) from the GCWR for the towing vehicle.

Trailer Weight Range

The trailer weight range is a specified range by weight, which the trailer must fall within, ranging from zero to the maximum trailer weight rating.

Calculating The Load

To know how much weight your vehicle can carry:

- Obtain ratings from your Safety Compliance Certification Label, and the Trailer towing specifications in the Owner Guide (refer to the Index)
 - Refer to the following sample illustration to locate the various ratings on your Safety Compliance Certification Label.
 - If you do not plan on pulling a trailer, do not include these ratings into your calculations.
- Weigh your vehicle as you customarily operate the vehicle (without cargo).
- Subtract the total weight of passengers, driver and optional equipment added by the factory, dealer or aftermarket supplier to determine how much cargo weight you can carry.

If you suspect that your payload is excessive, have your vehicle weighed at a highway weigh station or appropriate commercial facility. Weigh the total vehicle and trailer (if applicable), then separately weigh the vehicle at the front and rear wheels. And finally, weigh the trailer separately if applicable.

Use this chart to perform your calculations.

| Actual Weights | | |
|---------------------------------------------------------------------------------------------------------|----------------|-------------------------|
|  | | |
| GAW Front _____ | GAW Rear _____ | GAW Trailer _____ |
| GVW (GAW Front & Rear) _____ | | |
| GCW (Gross Combined Weight) (GAW Front & Rear & Trailer) _____ | | |
| Refer to your owner manual charts to find the maximum GCWR for your type of engine and rear axle ratio. | | |
| Ratings | Actual | Load Capacity Available |
| GAWR F _____ | _____ | _____ |
| R _____ | _____ | _____ |
| GVWR _____ | _____ | _____ |
| GCWR _____ | _____ | _____ |
| Subtract the actual weights from the ratings to determine the available cargo load capacity. | | |

NOTE: The Truck Safety Compliance Certification Label has two weight related entries that sometimes cause confusion.

Front Axle Reserve Capacity in Pounds (kgs): If this value is given as 83 pounds (38 kgs) on the label, does this mean that you are limited to adding only 83 pounds (38 kgs) of accessories to the front end capacity? Not exactly. This says

that you can load 83 pounds (38 kgs) of options on the front axle, add 150 pound (68 kgs) passengers to all seating positions, and add evenly distributed cargo in the box without exceeding the GAWR F.

It is possible to hang heavier equipment on the front as long as the vehicle owner/operator compensates. This can be accomplished, if necessary, by carrying fewer passengers, less cargo or positioning cargo more toward the rear, which has the effect of reducing the load on the front. Keep in mind that the GAWR F, GAWR R, nor the GVWR should ever be exceeded.

Total Accessory Reserve Capacity in Pounds (kgs): If, for example, this value is given as 112 pounds (51 kgs), does this mean that you are limited to adding 112 pounds (51 kgs) of accessories to your vehicle? Yes, that is correct for permanently installed accessories. This is a number that is related to government crash test standards. Therefore, no more than this weight should be permanently installed on your vehicle.

In the case of both these numbers (83 and 112 pounds) (38 and 51 kgs), the important thing to remember is that for safe operation, an owner/operator should calculate the amount and the distribution of all weights (passengers, accessory equipment and cargo). These combined weights should fall below the vehicle's GVWR and GAWR.

Trailers

Towing a trailer safely means having the proper weight on the tongue (usually 10% of the trailer weight). Load-equalizing hitches on large rigs may transfer weight to each of the vehicle's axles. This weight must be included in capacity calculations when determining if the vehicle is loaded within safe limits.

If your vehicle exceeds the GVWR, remove cargo from your vehicle accordingly. If your vehicle exceeds the GAWR for either axle, shift the load or remove cargo accordingly.

⚠ WARNING

Do not exceed the GVWR or the GAWR specified on the Safety Compliance Certification Label.

⚠ WARNING

Towing trailers beyond the maximum recommended gross trailer weight could result in engine damage, transmission/axle damage, structural damage, loss of control, and personal injury.

Use the Safety Compliance Certification Label to find the axle code number and the engine type for your vehicle.

Use the appropriate Maximum Gross Combined Weight Rating (GCWR) chart to find the Maximum GCWR for your type engine and rear axle ratio.

Subtract your Loaded Vehicle Weight from the Maximum GCWR found in the chart. This is the maximum trailer weight your vehicle can tow and must fall below the maximum shown under Trailer Weight on the chart.

MFD. BY FORD MOTOR CO. IN U.S.A.

DATE: _____ GVWR: _____

FRONT GAWR: _____ REAR GAWR _____

WITH TIRES RIMS | WITH TIRES RIMS

AT PSI COLD | AT PSI COLD

THIS VEHICLE CONFORMS TO ALL APPLICABLE FEDERAL MOTOR VEHICLE SAFETY STANDARDS IN EFFECT ON THE DATE OF MANUFACTURE SHOWN ABOVE.

VIN: _____

TYPE: _____



EXTERIOR PAINT COLORS _____ DSO _____

WB | BRAKES | BODY | TRANS | AXLE | TAPE | SPRINGS

23* ∇FOAT-15204A10-AA

* First two digits refer to Rear axle.

Rear Axle Codes

| Code | Description | Capacity | | Ratio |
|--------------------------------|-------------|----------|-------|-------|
| | | Lbs | Kgs | |
| AEROSTAR - Conventional | | | | |
| 22 | Ford | 2,900 | 1,315 | 4.10 |
| 23 | Ford | 2,950 | 1,338 | 3.45 |
| 24 | Ford | 2,950 | 1,338 | 3.73 |
| 29 | Ford | 2,950 | 1,338 | 3.55 |
| AEROSTAR - Conventional | | | | |
| B2 | Ford | 2,950 | 1,338 | 4.10 |
| B4 | Ford | 2,950 | 1,338 | 3.73 |
| B9 | Ford | 2,950 | 1,338 | 3.55 |

**Engine Type, Displacement,
Cylinders, Fuel Type,
and Manufacturer
(VIN Position 8)**

1 F T B F 2 5 **U** 5 E L A 0 0 0 0 1



| VIN Code | Displacement | | Cylinders | Fuel | Manufacturer |
|----------|--------------|-----|-----------|----------|--------------|
| | Liter | CID | | | |
| U | 3.0 | 182 | V-6 | Gasoline | Ford |
| X | 4.0 | 245 | V-6 | Gasoline | Ford |

Automatic Transmissions

| TRAILER TOWING TABLE – ALL MODELS | | | | |
|---------------------------------------------------------------------------------------------------------------------------------------------------------------------------------------------------------------------------------------------------------------------------------------------------------------------------------------------------------------------------------------------------|--------------------------------|-------------------------------------|-----------------------------------------------------------------|--------------------------------------------------------------------|
| GCWR (Gross Combined Weight Rating)/ Trailer Weights | | | | |
| Engine (EFI) | Rear Axle Ratio | Maximum GCWR Lb (Kg) | Trailer Weight Range Lb (Kg) (0-Maximum) | Maximum Frontal Area of Trailer Ft ² |
| VAN – 2WD REGULAR LENGTH | | | | |
| 3.0L | 3.73 | 7,500 (3,401) | 0-3900 (0-1,769) | 50 |
| WAGON – 2WD REGULAR LENGTH | | | | |
| 3.0L | 3.73 | 7,500 (3,401) | 0-3600 (0-1,632) | 50 |
| 3.0L | 4.10 | 8,000 (3,628) | 0-4100 (0-1,859) | 50 |
| WAGON – 2WD EXTENDED LENGTH | | | | |
| 3.0L | 4.10 | 8,000 (3,628) | 0-4000 (0-1,814) | 50 |
| 4.0L | 3.55 | 8,500 (3,855) | 0-4400 (0-1,995) | 50 |
| WAGON – 4WD EXTENDED LENGTH | | | | |
| 4.0L | 3.73 | 8,500 (3,855) | 0-4200 (0-1,905) | 50 |
| NOTES: | | | | |
| <ul style="list-style-type: none"> - For high altitude operation, reduce GCW by 2% per 1,000 ft. elevation. - For definition of terms used in this table see <i>Understanding Loading/Towing Information</i>. - To determine the maximum trailer weight designed for your particular vehicle as equipped, follow the section called <i>Calculating the Load</i>. | | | | |

Preparing to Tow

For your safety and for the good of your vehicle, use the right equipment for the type of trailer you tow. Also, make sure that all towing equipment is properly attached to your vehicle.

If you are not certain that you are using the right equipment in the proper manner, see your Ford or Lincoln-Mercury dealer.

Under certain circumstances, the trailer frontal area is not to exceed the base vehicle frontal area, no matter what size engine your vehicle has:

- If you drive on roads with steep grades or on roads with moderate grades that are 5 miles (8 km) or longer.
- If outside temperature in which you travel is above 100°F (38°C).

Hitches

For towing trailers up to 2,000 lb (907 kg), use a weight carrying hitch and ball which uniformly distributes the trailer tongue loads through the underbody structure. Use a frame-mounted weight distributing hitch for trailers over 2,000 lb (907 kg).

Do not install a single or multi-clamp type bumper hitch, or a hitch which attaches to the axle. Underbody mounted hitches are acceptable if installed properly. Follow towing instructions of a reputable rental agency.

Whenever a trailer hitch and hardware are removed, make sure all mounting holes in the underbody are properly sealed to prevent noxious gases or water from entering.

Safety Chains

Always use safety chains between your vehicle and trailer. Cross chains under the trailer tongue and allow slack for turning corners. Connect safety chains to the vehicle frame or hook retainers. **Never attach chains to the bumper.**

Trailer Brakes

Separate trailer brakes are required on most towed vehicles weighing over 1,500 lb (680 kg).

WARNING

Do not connect a trailer's hydraulic brake system directly to your vehicle's brake system. Your vehicle may not have enough braking power and your chances of having a collision greatly increase.

Trailer Lamps

Make sure your trailer lamps conform to Federal and local regulations.

Class I and Class II Trailer Tow electrical wiring provides two circuits (right hand and left hand) to operate trailer stop/turn tail lamps. Each stop/turn circuit will operate one combination stop/turn light bulb (# 1157, 3157, 2357, or 3357) on the trailer. Never add more than one trailer light bulb to one circuit.

WARNING

Always replace a fuse with one that has the specified amperage rating. Using a fuse with a higher amperage rating can cause severe wire damage and could start a fire.

Driving while you tow

Be especially careful when driving while you tow a trailer. Never drive faster than 45 mph (70 km/h) when you tow in hilly country on hot days. Also, anticipate stops so that you can brake gradually.

If you use the speed control while you are towing on very long, steep grades, the speed control may shut off.

When towing a trailer in hilly terrain, with a vehicle equipped with an automatic overdrive transmission, you may wish to operate in Drive (by cancelling Overdrive with OVERDRIVE OFF button) rather than **D** (Overdrive). This will eliminate excessive downshifting and upshifting to maintain speed. Switch back to Overdrive whenever practical for optimum powertrain cooling. This can be accomplished by pushing in the switch located on the end of the indicator lever.

When descending a steep grade with a trailer, operate in Drive rather than Overdrive. If additional braking is needed, shift the automatic transmission gearshift into the 2 (Second) or 1 (Low) position.

Servicing your vehicle if you tow

If you tow a trailer for a long distance, your vehicle will need to be serviced more frequently than usual. Refer to the *Maintenance Schedule* booklet for additional information.

Trailer Towing Tips

Before starting on a trip, practice turning, stopping and backing in an area away from heavy traffic. Get to know the “feel” of the vehicle/trailer combination.

Practice backing up. Back up very slowly, with someone outside at the rear of your trailer to guide you. Place your hand at the bottom of the steering wheel and move it in the direction you want the rear of the trailer to swing. Slight movement of the steering wheel results in a much larger movement of the rear of the trailer.

Allow more room for stopping with a trailer attached. Trailer brakes should be applied first, whether manually or automatically controlled, when approaching a stop.

For a good handling truck-trailer combination, the trailer tongue load should be approximately 10-15% of the loaded trailer weight.

Make a thorough check of your equipment before starting out on the road. After you have traveled about 50 miles (80 km) stop in a protected area and double-check your hitch and electrical connections. Also check trailer wheel lug nuts for tightness.

When turning, drive slightly beyond the normal turning point so the trailer wheels will clear curbs or other obstructions.

When stopped in traffic for long periods of time in hot weather, place the gearshift selector lever in P (PARK) to increase the engine idle speed. This aids in engine cooling and air conditioner efficiency. If the engine overheats, move the function selector knob to VENT to stop the compressor and increase the engine speed for a short time.

 **WARNING**

Do not tow a trailer when using a temporary spare tire.

Vehicles with trailers should not be parked on a grade. However, if you must park on a grade, place wheel chocks under the trailer's wheels as follows:

- Apply the brake pedal and hold.
- Have another person place the wheel chocks under the trailer wheels.

- With the chocks in place, release the brake pedal, making sure the chocks are holding.
- Apply the parking brake by pressing the brake pedal down firmly with your right foot while applying the parking brake with your right hand.
- Shift the gearshift lever into P (Park).

To start, after being parked on a grade:

- Apply the brake pedal and hold.
- Start the engine.
- Shift transmission into gear and release the parking brake.
- Release the brake pedal and move the vehicle uphill to free the wheel chocks.
- Apply the brake pedal and hold while another person retrieves the chocks.

Luggage Rack (If equipped)

Always distribute your luggage load evenly. Do not load more than 100 pounds (45 kg) onto rack or cause the vehicle to exceed the Gross Vehicle Weight Rating (GVWR).

The crossbars and cross slats are adjustable. Loosen the adjustment screws, slide the bars and slats as necessary, and retighten the screws.

| |
|----------------------------------------------------------------------------------------------------|
|  WARNING |
|----------------------------------------------------------------------------------------------------|

| |
|-------------------------------------------------------------------|
| Be sure that items on the roof rack are securely fastened. |
|-------------------------------------------------------------------|

Use caution to avoid scratching the paint. Drive carefully and avoid sudden starts and stops.

Roadside Emergencies

Hazard Flasher

The hazard flasher is used to alert other drivers to hazardous situations.

The flashers will continue to flash with the brake pedal depressed.

The flashers work whether your vehicle is running or not. The flashers work for up to two hours when the battery is fully charged and in good condition without draining the battery excessively. If the flashers run for longer than two hours or if the battery is not fully charged, the battery power can be drained.

To use the hazard flasher:

1. Push in the flasher button; it will pop out and the lamps will begin to flash.
2. To stop the flashers, push in the flasher button again.

NOTE: The flasher button will be sticking up slightly higher when on than when off.

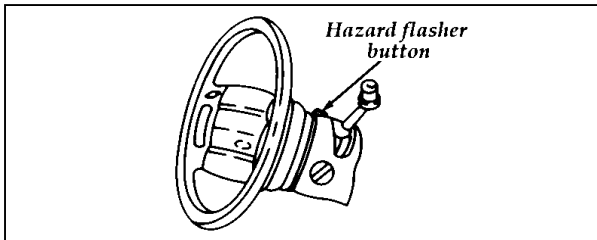

Hazard flasher

If the Engine Cranks But Does Not Start or Does Not Start After a Collision

The Fuel Pump Shut-off Switch

If the engine cranks but does not start or if you have had a collision, the fuel pump shut-off switch may have been triggered. The shut-off switch is a device that stops the fuel pump when your vehicle has been involved in a substantial jolt.

For information on how to check and reset the fuel pump shut-off switch, see *Fuel pump shut-off switch* in the Index.

Fuses

Fuses and circuit breakers protect your vehicle's electrical system from overloading. If electrical parts in your vehicle are not working, the system may have been overloaded and blown a fuse or tripped a circuit breaker. Before you replace or repair any electrical parts, check the appropriate fuses or circuit breakers.

The following charts tell you which fuses or circuit breakers protect each electrical part of your vehicle. If a fuse blows or a circuit breaker opens a circuit, all the parts of your vehicle that use that circuit will not work.

| If these parts do not work. . . | Check fuse number |
|---------------------------------------------------------------------------------------------------------------------------------------------------------------|--------------------------|
| Brakelamps, emergency Flasher, Transmission Stuck in Park | 1 – 15 amp, light blue |
| Front Wiper Washer | 2 – 6 amp. C.B. |
| RABS – Keep-Alive Memory Power, Exterior Lamps, Lamps on Warning, DRL Module | 4 – 15 amp, light blue |
| Turn Lamps, Back-Up Lamps, Heated Rear Window, Daytime Running Lamps, Transmission Stuck in Park | 5 – 15 amp, light blue |
| A/C Clutch Switch, Door Ajar, Speed Control, Warning Chime, Illuminated Entry | 6 – 20 amp, yellow |
| Anti-Lock Brakes | 7 – 20 amp, yellow |
| Visor Vanity Lamp, Power Mirrors, Glove Box Lamps, Front dome/Map Lamps, Courtesy Lamps, Rear Cargo Lamp, Stepwell Lamp, Reading Lamp, Radio, Clock, Odometer | 8 – 15 amp, light blue |
| Heater and A/C Motor Blower | 9 – 3-0 amp, light blue |
| Air Bag Module | 10 – 15 amp, light blue |
| Radio/Tape Player, | 11 – 15 amp, light blue |
| Flash-to-Pass, Horn | 12 – 15 amp, light green |
| Instrument Panel Illumination Lamps, | 13 – 5 amp, tan |
| Power Window | 14 – 20 amp C.B. |
| Power Locks | 30 amp, In-line* |

*Located above fuse block—left cowl side.

| If these parts do not work... | Check fuse number |
|-----------------------------------------------------------------------------|--------------------------|
| Electronic 4 Wheel Drive, E4WD Warning Lamps | 15 – 15 amp, light blue |
| Front Cigar Lighter, Rear Cigar Lighter | 16 – 20 amp, yellow |
| PSOM | 17 – 10 amp, red |
| Instrument Cluster Gauges, Rear Washer/Wiper, Seatbelt Chime, Warning Lamps | 18 – 15 amp, light blue |
| Rear Wiper Motor, Rear Washer Pump | 4.5 amp, C.B. |
| Transmission Control Switch | 18 – 15 amp, blue |

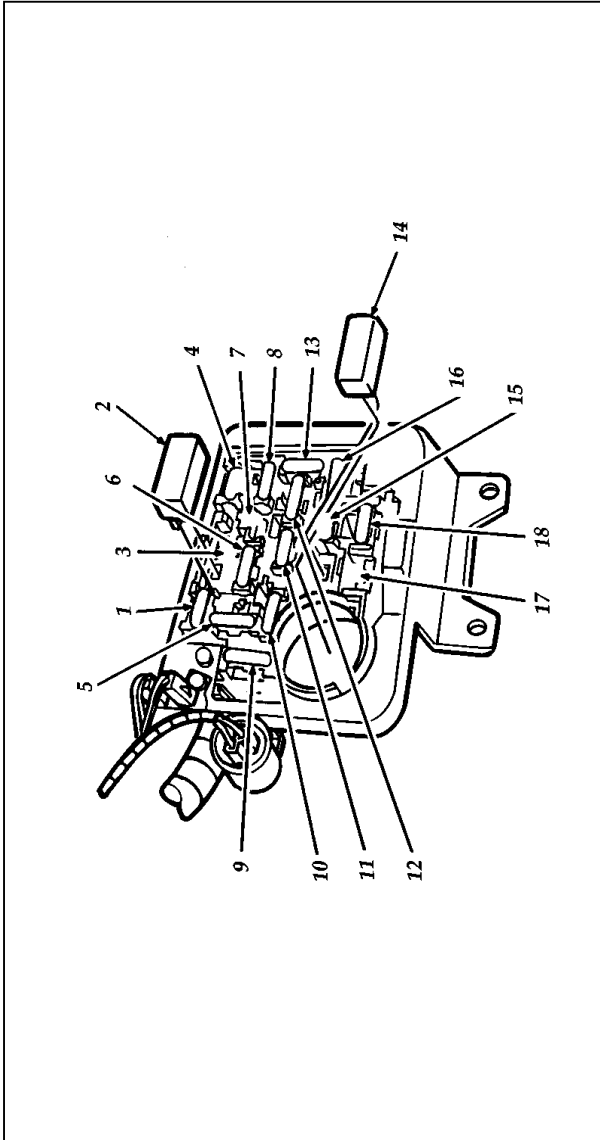

Fuses and their location (under instrument panel on driver's side)

| Fuse/CB/ Relay Loc. | Fuse Amp. Rating | Description |
|------------------------------------|---------------------------------|-------------------------------------------------------------------------------------------------------------------------------------------------------------------------------------------------------------------------------------------------------------------------------|
| 1 | 15 Amp | <ul style="list-style-type: none"> • Brake shift interlock • Hazard flashers • Indicator lamps (turn signal) • Speed control • Stop lamps |
| 2 | 6 Amp | <ul style="list-style-type: none"> • Windshield wiper/washer |
| 3 | — | Not used |
| 4 | 15 Amp | <ul style="list-style-type: none"> • Daytime running lamps (DRL) • Headlamp ON warning chime • Instrument panel illumination • License lamps • Parking lamps • Rear Anti-Lock Brakes • Side marker lamps |
| 5 | 15 Amp | <ul style="list-style-type: none"> • Airbag module • Back-up lamps • Brake shift interlock • Daytime running lamps module (DRL) • Rear defroster switch • Turn signal flasher • Turn signal indicator |
| 6 | 20 Amp | <ul style="list-style-type: none"> • Air conditioning clutch • Door ajar relay • Illuminated Entry Timer • Speed control amplifier |
| 7 | 20 Amp | <ul style="list-style-type: none"> • Rear anti-lock brake system (RABS) module |

| Fuse/CB/ Relay Loc. | Fuse Amp. Rating | Description |
|------------------------------------|---------------------------------|-----------------------------------------------------------------------------------------------------------------------------------------------------------------------------------------------------------------------------------------------------------------------------------------------------------------------------------------------------------------------------------------------------|
| 8 | 15 Amp | <ul style="list-style-type: none"> • Cargo lamp • Courtesy lamp • Dome lamp • Glove box lamp • Illuminated entry • Instrument panel courtesy lamps • Power mirrors • Programmable speedometer/odometer module (PSOM) • Radio • Reading lamps • Stepwell lamp • Visor vanity lamps |
| 9 | 30 Amp | <ul style="list-style-type: none"> • Auxiliary air conditioning relay • Blower motor • Front air conditioning |
| 10 | 15 Amp | <ul style="list-style-type: none"> • Air bag module |
| 11 | 15 Amp | <ul style="list-style-type: none"> • Premium Sound amp • Radio |
| 12 | 30 Amp | <ul style="list-style-type: none"> • Flash-to-pass • High beam indicator • Horn |
| 13 | 5 Amp | <ul style="list-style-type: none"> • Instrument and control illumination |
| 14 | 20 Amp | <ul style="list-style-type: none"> • Power window motors |
| 15 | 15 Amp | <ul style="list-style-type: none"> • All wheel drive (AWD) and indicator |
| 16 | 20 Amp | <ul style="list-style-type: none"> • Front cigar lighter • Rear cigar lighter |

| Fuse/CB/ Relay Loc. | Fuse Amp. Rating | Description |
|------------------------------------|---------------------------------|------------------------------------------------------------------------------------------------------------------------------------------------------------------------------------------------------------------------------------------------------|
| 17 | 10 Amp | <ul style="list-style-type: none"> • Programmable speedometer/ odometer module (PSOM) |
| 18 | 15 Amp | <ul style="list-style-type: none"> • Indicator lamps • Instrument cluster gauges • Liftgate wiper motor • Liftgate wiper/washer switch • Transmission control switch • Warning chime |

| If these parts do not work... | Look for...* | Location | Color |
|-----------------------------------|---------------------|-------------------------------------------|-------|
| Auxiliary Heater or A/C | 18 GA. Fuse Link | Starter Motor Relay | Brown |
| Alternator | 12 GA. Fuse Link | Starter Motor Relay | Gray |
| Trailer, Datalink Connector | 20 GA. Fuse Link | Starter Motor Relay | Blue |
| Heated Backlite/Power Locks | 18 GA. Fuse Link | Starter Motor Relay | Brown |
| Headlamp Switch Feed | 16 GA. Fuse Link | Starter Motor Relay | Black |
| Headlamps and High Beam Indicator | 22 Amp. Circ. Brkr. | Integral with Headlamp Switch | |
| Ignition Switch Feed | 16 GA. Fuse Link | Starter Motor Relay | Black |
| Powertrain Control Module | 20 GA. Fuse Link | Starter Motor Relay | Blue |
| PCM KAM | 10 Amp. Fuse | In-Line located in the Engine Compartment | Red |

NOTE: Under NO circumstances, use more than an 8.5 ampere load across the ignition switch terminals for the rear light circuit on ANY truck or bus which used the hydraulic brakelamp switch.

FUSE LINK COLOR CODE: BLUE = 20 GA, BROWN = 18 GA, BLACK = 16 GA, GREEN = 14 GA, GRAY = 12 GA

*Look near battery for fuse links.

To remove and replace a fuse, use the fuse puller provided.

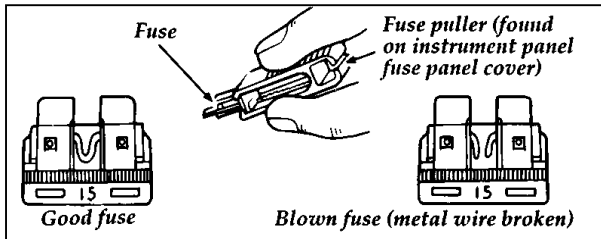

The side view of a fuse

| |
|--------------------------------------------------------------------------------------------------------------------------------------------------------------------------------------|
| ⚠ WARNING |
| <p>Always replace a fuse with one that has the specified amperage rating. Using a fuse with a higher amperage rating can cause severe wire damage and could start a fire.</p> |

Access to the trailer tow fuse is through the rear most storage compartment in the side trim panel. This is on the left for all Aerostar models.

1. Remove the screws located inside the compartment and take off the access hole cover.
2. Reach in through access hole to remove fuses. The fuses are located on the side of the bracket assembly.
3. Replace fuses with standard push-in fuses (plug type).
4. Reinstall compartment back and screw into place.

Even after you replace a fuse, it may continue to blow if you do not find what caused the overload. If the fuse continues to blow, have your electrical system checked.

Circuit Breakers

If you need to check a circuit breaker, locate the fuse panel first. Otherwise, locate the circuit breaker according to the instructions on the charts given earlier in this chapter.

However, you should know that the circuit breakers will reset themselves and allow the electrical parts to work again once the overload on the circuit is removed. If the circuit breakers continue to cut off electricity, have your vehicle's electrical system checked.

Diagnostic equipment is needed to check circuit breakers. Refer to the manufacturer's instructions.

If you replace a circuit breaker, use one with the same amperage rating. To remove a circuit breaker, grip it with your finger and thumb and pull it straight out of its socket.

Changing a Tire

If you get a flat tire while you are driving, do not apply the brake heavily. Instead, gradually decrease the speed. Hold the steering wheel firmly and slowly move to a safe place on the side of the road. Park on a level spot, turn off the ignition, set the parking brake, and turn on the hazard flashers.

The Conventional Spare Tire

If you have the conventional spare tire, you can use it as a spare or as a regular tire. This spare tire is identical to the other tires that come with your vehicle, although the wheel may not match.

The Temporary Spare Tire

You may have a high pressure temporary spare tire. This spare tire is smaller than a regular tire and is designed for emergency use only. Use it only when you get a flat tire and replace it as soon as you can. This spare tire is marked with the words "TEMPORARY USE ONLY" so that you can easily identify it.

| |
|------------------|
| ⚠ WARNING |
|------------------|

| |
|----------------------------------------------------------------------------------------------------------------------------------------------------------------------------------------------------|
| If you use the temporary spare tire continuously or do not follow these precautions, the tire could fail, causing you to lose control of the vehicle, possibly injuring yourself or others. |
|----------------------------------------------------------------------------------------------------------------------------------------------------------------------------------------------------|

| |
|------------------|
| ⚠ WARNING |
|------------------|

| |
|-------------------------------------------------------|
| The tire size on the E-4WD must be maintained. |
|-------------------------------------------------------|

Your vehicle may have a full diameter mini spare or a full size tire. This full diameter mini spare is special for the E-4WD and another mini spare from another vehicle can not be substituted without the possibility of damage to your vehicle. All tires should be inflated to the manufacturer's recommended pressures.

| |
|------------------|
| ⚠ WARNING |
|------------------|

| |
|-----------------------------------------------------------------------------------------------------------|
| To avoid injury, never run the engine with one wheel off the ground, such as when changing a tire. |
|-----------------------------------------------------------------------------------------------------------|

Extended use of other than matching size spare tires on a Traction-Lok axle could result in a permanent reduction in effectiveness. This loss of effectiveness does not affect normal driving and should not be noticeable to the driver.

**When you drive with the temporary spare tire,
DO NOT:**

- exceed 50 mph (80 km/h) under any circumstances.
- load your vehicle so that it is heavier than the maximum vehicle load rating listed on the tire decal.
- tow a trailer.
- use tire chains on this tire.
- try to repair the temporary spare tire or remove it from its wheel.
- use the wheel for any other type of vehicle.
- drive through an automatic car wash with this tire. Because the temporary spare tire is smaller than a conventional tire, it reduces the ground clearance. Your vehicle may get caught in the rails and it could be damaged.

Spare Tire Location

If your vehicle is a standard length van model, the spare tire is mounted inside a carrier at the left rear quarter panel. To remove the spare tire, remove the wing nut and plate. A flat tire can be temporarily stowed in the same location.

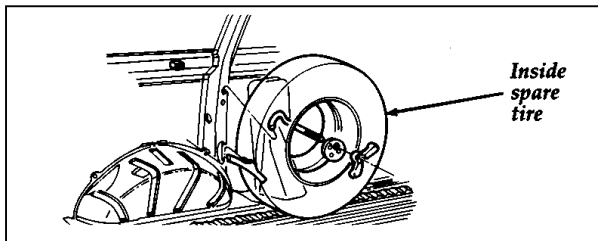

A side mounted spare tire

If your vehicle is the model with a standard length body or extended length (all models), the temporary spare tire is stowed at the rear of the vehicle under the body.

The standard length E-4WD model spare tire is mounted on the floor.

To remove underbody temporary spare tire:

1. Insert lug nut wrench into the actuator hole and turn counterclockwise until the cable extends to allow the spare tire to be pulled rearward from under the vehicle.
2. Slide the spare tire to the rear and remove the retainer from the wheel.
3. To stow cable/retainer with spare tire removed, insert cable fitting into carrier rear wall slot, place wheel retainer against the carrier, and turn lug nut wrench clockwise until slack is removed.

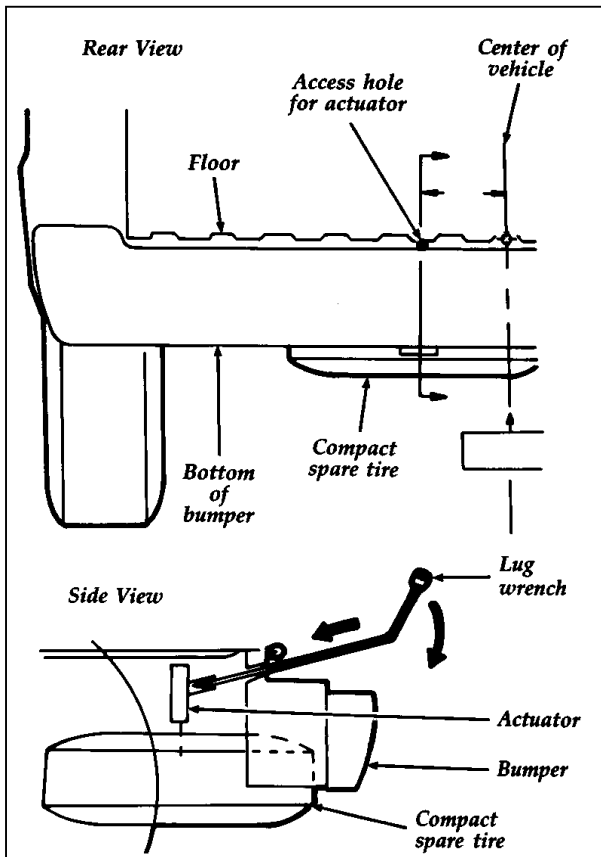

Temporary spare tire location and assembly

To stow underbody temporary spare tire:

1. Insert lug nut wrench into the actuator hole and turn counterclockwise until the cable/retainer is extended for insertion into the wheel.
2. Install the retainer through wheel center with valve stem facing up.

3. Rotate wrench clockwise until tire is secured. (Raising mechanism will slip.)
4. Check for proper seating against underbody supports and retighten if necessary.

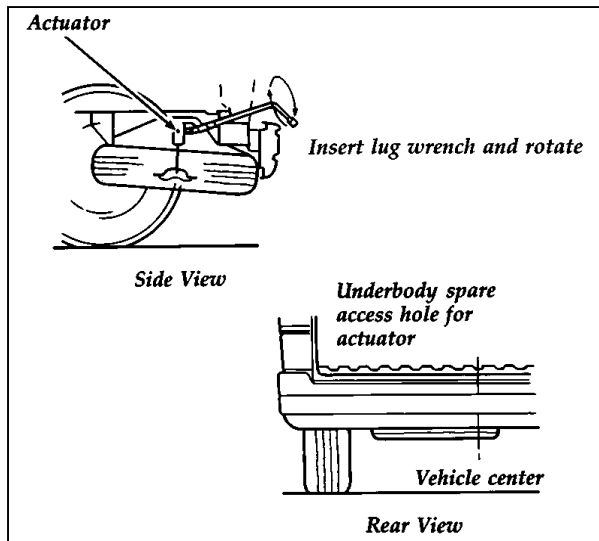

Spare tire — underbody carrier

⚠ WARNING

Do not stow any conventional spare tire or flat temporary spare tire in the underbody position. Doing so may cause damage to the tire, rear axle, or brake lines. (Standard length only)

A flat tire can be temporarily secured to the floor pan under the rear-most seat. To temporarily secure a flat tire:

1. Remove the spare tire “J” bolt, plate and wing nut from their stowed location on the jack.

2. Position the flat tire, valve stem up, under the rear-most seat and over the "J" bolt attaching bracket on the floor pan.
3. Insert the "J" hook bolt through the center of the wheel and hook on bracket.
4. Install plate over "J" hook bolt and secure with wing nut.

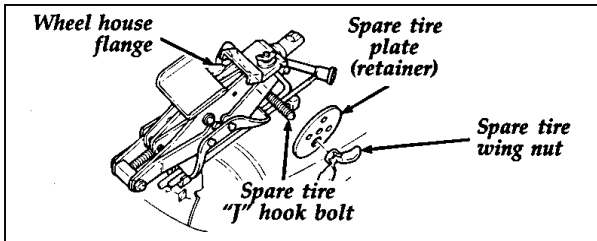

A Stowed position of "J" bolt, plate and wing nut (Standard length model)

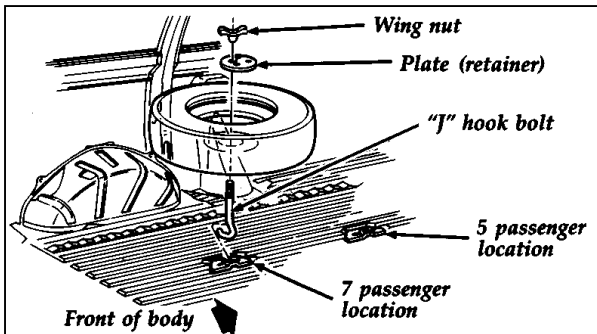

Flat tire stowage (Standard length model)

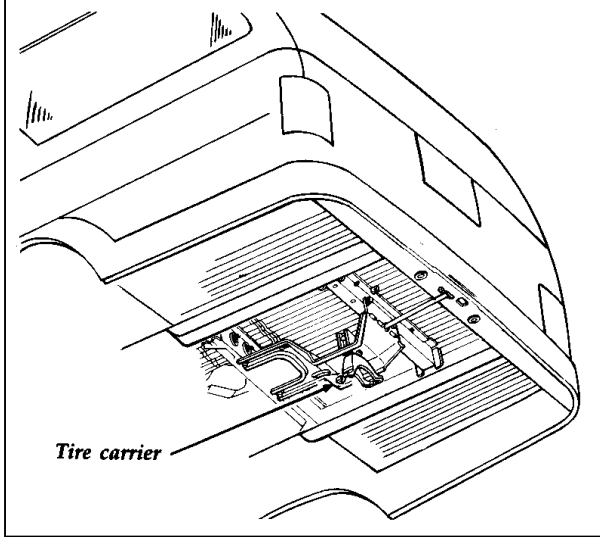

Extended van underbody outside spare wheel/flat tire storage

⚠ WARNING

Make sure the spare tire and jacking equipment are stowed and secured in the proper storage location.

Preparing to Change the Tire

NOTE: To lift your vehicle by other than the front or rear jacking points, be sure to use only hoist adapters with a wide contact surface.

1. Make sure that your vehicle will not move or roll. Put the gearshift in P (Park). Set the parking brake and block the wheel that is diagonally opposite the tire that you are changing.

NOTE: Make sure the ignition is in the OFF position.

When one of the back wheels is off the ground, the transmission alone will not prevent the vehicle from moving or slipping off the jack, even if the vehicle is in P (Park). To prevent the vehicle from moving when you change a tire, be sure the parking brake is set, then block the wheel (both directions) that is diagonally opposite (other side and end of the vehicle) to the tire being changed.

⚠ WARNING

If the vehicle slips off the jack, you or someone else could be seriously injured.

2. Get out the spare tire and jack.

The jack, jack handle and lug nut wrench are stowed separately on the left hand wheelhouse inner panel on standard length models. And in the right rear storage compartment on extended length models.

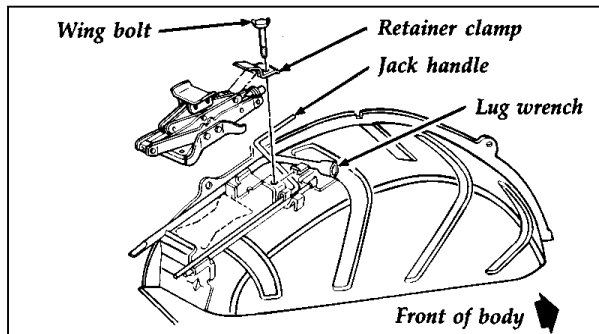

Jack stowage

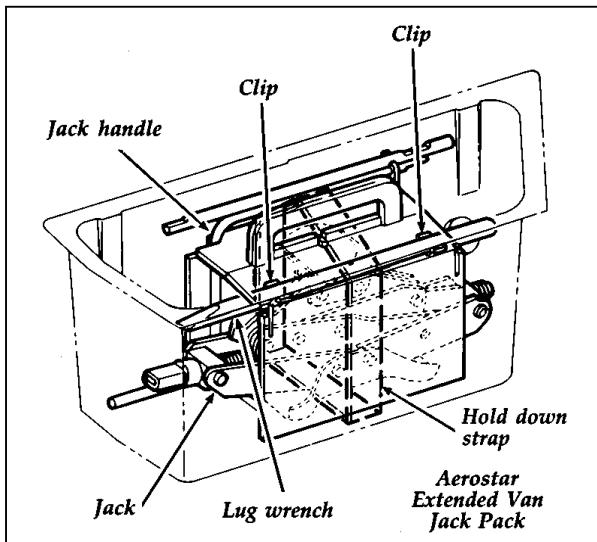

Aerostar extended model jack pack

3. Use the tapered end of the lug nut wrench to unscrew wheel ornaments attached by retaining screws. Remove any wheel trim. Insert the tapered end of the lug nut wrench behind wheel covers or hubcaps and twist off.
4. Loosen the wheel nuts by pulling up on the handle of the lug nut wrench about one-half turn (counterclockwise). Do not remove the wheel lug nuts until you raise the tire off the ground.
5. Unfold the jack handle and lock into the jack. Use the jack handle to slide the jack under the vehicle.

Removing and Replacing the Tire

1. Positioning the jack
 - a. To raise a front wheel, place the jack under a horizontal portion of the underbody member behind the wheel, as shown.

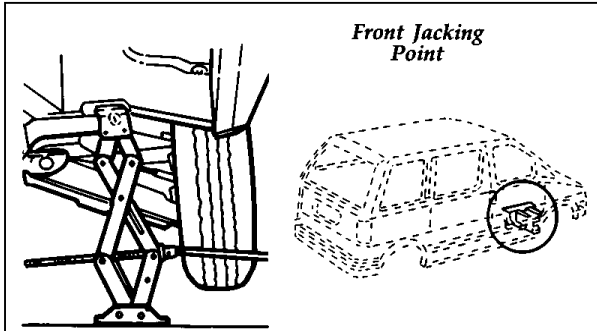

Front jacking point

- b. To raise a rear wheel, place the jack under a horizontal portion of the underbody member ahead of the wheel as shown.

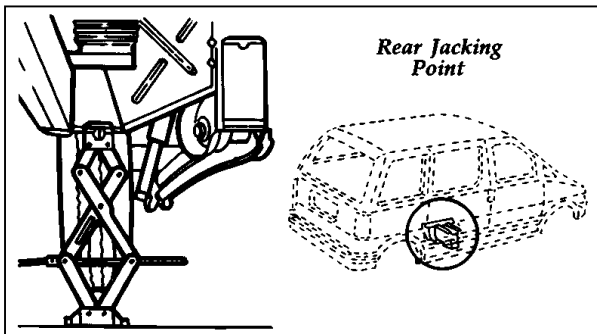

Rear jacking point

- c. Turn the jack handle clockwise until the wheel is completely off the ground.

⚠ WARNING

Never place the jack under the rocker panels.

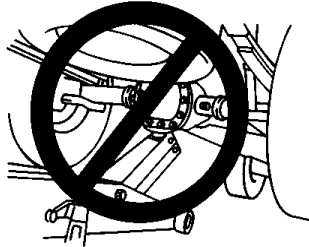

NEVER USE THE DIFFERENTIAL HOUSING AS A LIFT POINT.

2. Remove the lug nuts with the lug nut wrench.
3. Replace the flat tire with the spare tire.
4. Thread the lug nuts on the wheel studs with the beveled face toward the wheel. Use the lug nut wrench to screw the lug nut snug against the wheel but do not tighten.
5. Lower the vehicle by turning the jack handle counterclockwise.
6. Remove the jack and fully tighten the lug nuts in the order shown in the following illustration.

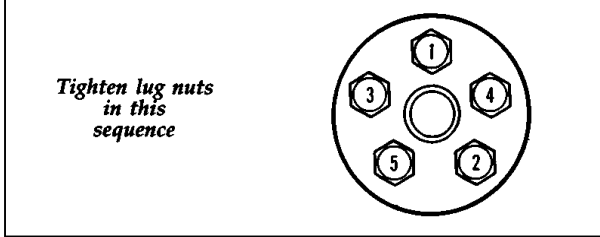

Lug nut tightening sequence

⚠ WARNING

Never use wheels or lug nuts different than the original equipment as this could damage the wheel or mounting system. This damage could allow the wheels to come off while the vehicle is being driven.

7. Replace any wheel covers, ornaments, or hub caps that your vehicle has. Make sure that they are screwed or snapped into place.
8. Put the tire, jack, and wrench away. Make sure jack is securely fastened so it doesn't rattle when you drive. The carrier is designed to hold the temporary spare which comes with your vehicle. The stowage of a full size tire in the spare tire carrier may damage the tire or the vehicle. The flat full size tire should be stowed securely in the vehicle until it can be repaired.
9. Unblock the wheels.

Retighten the wheel lug nuts to the specified torque at 500 miles (800 km) of new vehicle operation and at intervals specified in the *Maintenance Schedule* booklet.

Also retighten to the specified torque at 500 miles (800 km) of operation after any wheel change or any time the lug nuts are loosened.

| |
|---------------------------------------------------------------------------------------------------------------------------------|
| ⚠ WARNING |
| Failure to retighten wheel lug nuts at mileages specified could allow wheels to come off while the vehicle is in motion. |

| Model | Bolt Size | Wheel Lug Nut Torque* | |
|----------|-----------|-----------------------|-----|
| | | Ft-Lb | N•m |
| Aerostar | 1/2-20 | 100 | 135 |

*Torque specification is for nut and bolt threads free of dirt and rust. Do not use oil or grease on threads. Use only Ford recommended replacement fasteners.

Jump-Starting Your Vehicle

Your vehicle's battery may die if you leave the lights on or any electrical equipment on after you turn the engine off. If this happens, you may be able to jump-start your vehicle with a booster battery.

| |
|---------------------------------------------------------------------------------------------------------------------------------------------------------|
| ⚠ WARNING |
| The gases around the battery can explode if exposed to flames, sparks, or lit cigarettes. An explosion could result in injury or vehicle damage. |

| |
|---------------------------------------------------------------------------------------------------------------------------------|
| ⚠ WARNING |
| To protect yourself when charging a battery, always shield your face and eyes. Make sure that you can breathe fresh air. |

⚠ WARNING

Applying too much pressure on the ends when lifting a battery could cause acid to spill. Lift the battery with a carrier or with your hands on the opposite corners.

⚠ WARNING

Batteries contain sulfuric acid which burns skin, eyes, and clothing.

If the acid touches someone's skin, eyes, or clothing, immediately flush the area with water for at least 15 minutes. If someone swallows the acid, have him or her drink lots of milk or water first, then Milk of Magnesia, a beaten egg, or vegetable oil. Call a doctor immediately.

⚠ WARNING

Do not push-start your vehicle. You could damage the catalytic converter. For further information, see *Jumper Cables* in the Index.

To avoid damaging your vehicle or your battery, and to avoid injury to yourself, follow these directions for preparing your vehicle to jump-start and connecting the jumper cables in the order they are given. If in doubt, call for road service.

Preparing Your Vehicle

1. Your vehicle has a 12-volt starting system, so you need to use a 12-volt jumper system. You will damage your starting motor, ignition system, and other electrical parts if you connect them to a 24-volt power supply (either two 12-volt batteries in series or a 24-volt generator set).

2. Do not disconnect the battery of the disabled vehicle. You could damage the vehicle's electrical system.
3. Park the booster vehicle close to the hood of the disabled vehicle. **Make sure the vehicles do not touch each other.** Set the parking brake on both vehicles and stay clear of the engine cooling fan and other moving parts.
4. Check all battery terminals and remove any excessive corrosion before you attach the jumper cables.
5. Turn on the heater fan in both vehicles. Turn the function selector knob to the  position. Turn off all other switches.

Connecting the jumper cables

1. Connect one end of the first jumper cable to the positive (+) terminal of the discharged battery. (You can connect either jumper cable to the positive (+) terminal, as long as you use the same cable for both positive terminals.) Most jumper cables have a red cable and a black cable. The red cable is generally used for the positive terminals and the black for the negative ones.
2. Connect the other end of the first cable to the positive (+) terminal of the booster battery.
3. Connect one end of the second cable to the negative (-) terminal of the booster battery — NOT to the discharged battery.
4. Connect the other end of that cable to a good metallic surface on the engine or frame of the disabled vehicle. The following illustration shows where you can find a metallic surface.

⚠ WARNING

Do not connect the end of the second cable to the negative (–) terminal of the battery to be jumped. A spark may cause an explosion of the gases that surround the battery.

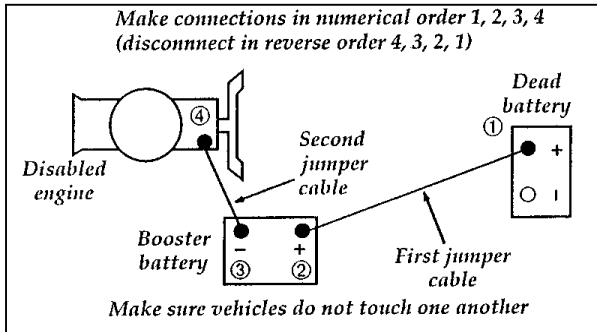

Attaching jumper cables

Jump-Starting

1. Make sure that the jumper cables are not in the way of moving engine parts, then start the booster vehicle. Run the engine at a moderate speed.
2. Let the discharged battery charge for a few minutes and then start the disabled vehicle. It may take a couple of tries before the vehicle starts. If the vehicle does not start after several attempts, there may be a different problem.
3. When both vehicles are running, let them idle for a few minutes to charge the discharged battery.

Removing jumper cables

1. **Always remove the jumper cables in the reverse order.** Remove the negative (–) end of the jumper cable from the metallic surface on the engine or frame of the disabled vehicle.
2. Remove the negative (–) cable from the booster battery.
3. Remove the positive (+) cable from the booster battery.
4. Remove the other end of the positive (+) cable from the discharged battery.

After the vehicle is started, let it idle for a while to let the engine “relearn” its idle conditions. Drive it around for a while with all electrical accessories turned off to let the battery recharge. Driveability may be deteriorated slightly until all drive modes are “relearned.” **You may need to use a battery charger to fully recharge the battery.**

If you need to replace your battery, see *Battery* in the *Maintenance and Care* chapter.

Towing Your Vehicle

The recommended method to tow your Aerostar is with flatbed or wheel lift equipment. However, slingshot towing is acceptable. On vehicles equipped with an under-vehicle spare tire carrier, remove the tire assembly from the carrier and store it in a secure area before towing. For E-4WD vehicles, the 4-wheel drive system must be disabled prior to towing. The transmission must be in N (Neutral) and the ignition switch must be in the OFF position to disable the Electronic 4-Wheel Drive System.

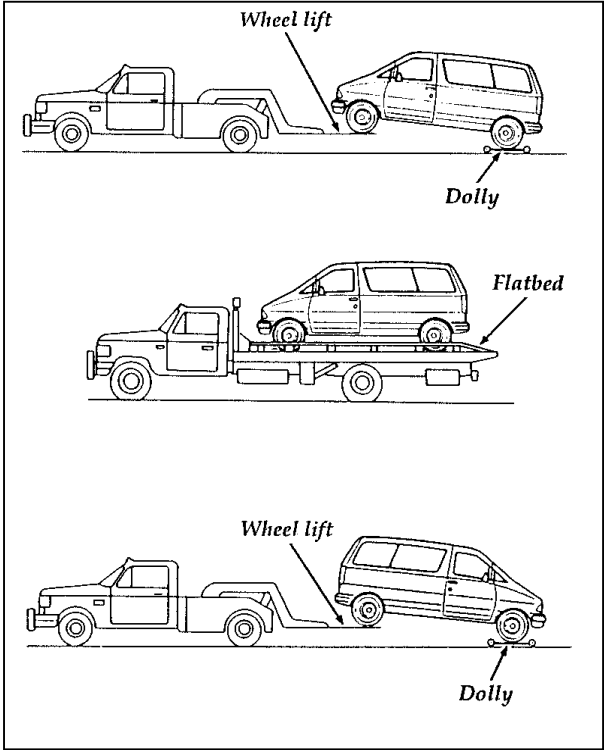

Maintenance and Care

Service Made Easy

Ford has two goals for servicing your vehicle.

1. When we can, we design parts that do not need to be serviced.
2. We want to make servicing your vehicle as easy as possible. To help you:
 - We highlight do-it-yourself items in yellow in the engine compartment so that you can find them easily.
 - When possible, we design parts that can be replaced without tools.
 - We give you a Maintenance Schedule that makes tracking routine service for your vehicle easy. The maintenance schedule is located in the *Maintenance Schedule* booklet.

This chapter tells you about the basic parts that you need to check and service regularly.

If your vehicle needs professional servicing, your dealership can provide the parts and service required. Check your *Warranty Information Booklet* to find out which parts and services are covered. Also see the *Customer Assistance* chapter of this Owner Guide.

Ford Motor Company recommends that you perform the Owner Maintenance Checks listed in the *Maintenance Schedule* booklet. These services are important for the proper operation of your vehicle. In addition to the conditions listed in the Owner Maintenance Checklist, be alert for

any unusual noise, vibration, or other indication that your vehicle may need service. If you do notice something unusual, see that your vehicle is serviced promptly.

Use only recommended fuels, lubricants, fluids, and service parts conforming to Ford specifications. Motorcraft parts are designed and built to provide the best performance in your vehicle. Using these parts for replacement is your assurance that Ford-built quality stays in your vehicle.

NOTE: Always dispose of used automotive fluids in a responsible manner. Follow your community's standards for disposing of these types of fluids. Call your local recycling center to find out about recycling automotive fluids.

Precautions When Servicing Your Vehicle

Be especially careful when inspecting or servicing your vehicle. Here are some general precautions for your safety:

- If you must work with the engine running, avoid wearing loose clothing or jewelry that could get caught in moving parts. Take appropriate precautions with long hair.
- Do not work on a vehicle in an enclosed space with the engine running, unless you are sure you have enough ventilation.
- Never get under a vehicle while it is supported only by a jack. If you must work under a vehicle, use safety stands.
- Keep all lit cigarettes and other smoking materials away from the battery and all fuel-related parts.

If you disconnect the battery, the engine must “relearn” its idle conditions before your vehicle will drive properly. To find out how the engine does this, see *Battery* in this chapter.

Working with the engine off:

1. Set the parking brake fully and make sure that the gearshift is securely latched in P (Park).
2. Remove the key from the ignition after you turn the engine off.
3. Block the wheels. This will prevent your vehicle from moving unexpectedly.

Working with the engine on:

1. Set the parking brake fully and make sure that the gearshift is securely latched in P (Park).
2. Block the wheels. This will prevent your vehicle from moving unexpectedly.

⚠ WARNING

Do not start your engine with the air cleaner removed and do not remove it while the engine is running.

Opening the Hood

1. Pull the hood release handle, located next to the parking brake pedal.

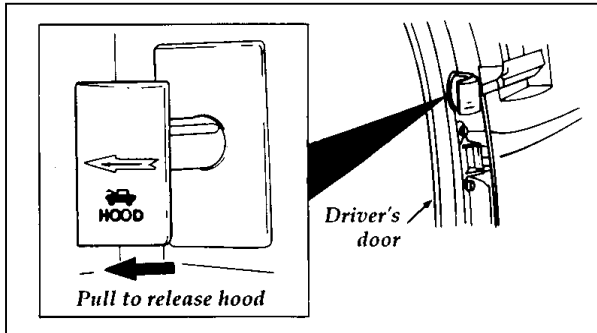

Hood release handle

2. While applying downward pressure on the hood, push the hood latch handle located behind the grille near the center front of the vehicle to the left.
3. Disconnect the hood support from the retaining clip on the radiator support and place it into the slot marked PROP in the underside of the hood.

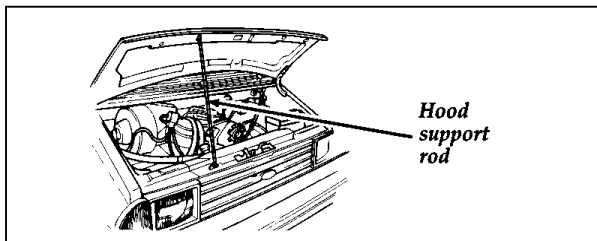

Hood and support rod

To close the hood, raise it so that the support rod comes away from the slotted hole in the hood. Place the support rod in its retaining clip and close the hood with enough force to make it latch. Be sure to oil the hood latch every six months to maintain smooth operation.

Always attempt to lift the hood after closing to be sure it is securely latched.

Engine Oil Recommendations

We recommend using Motorcraft oil or an equivalent oil meeting Ford Specification WSS-M2C153-F and displaying the American Petroleum Institute CERTIFICATION MARK on the front of the container.

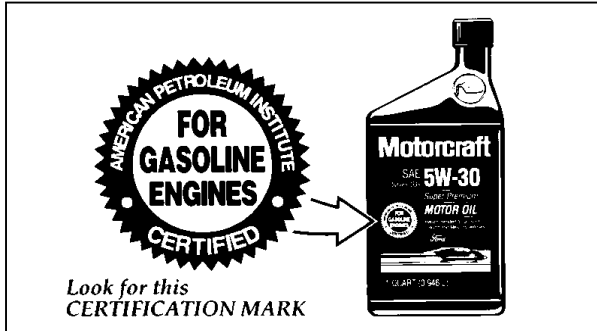

The API Certification Mark

Never use:

- "Non-Detergent" oils
- Oils labeled API SA, SB, SC, SD, SE, SF or SG
- Additional engine oil additives, oil treatments or engine treatments

Engine oils with an **SAE 5W-30** viscosity are **PREFERRED** for your vehicle. They provide the best engine performance, fuel economy and engine protection for all climates down to -15°F (-25°C).

Synthetic engine oils which are **CERTIFIED** and of the preferred viscosity may be used in your engine. The engine oil and oil filter must still be changed according to the maintenance schedule.

NOTE: Ford production and aftermarket (Motorcraft) oil filters are designed for added engine protection and long life. If a replacement oil filter is used that does not meet Ford material and design specifications, startup engine noises or knock may be experienced. It is recommended you use the appropriate Motorcraft oil filter (or another brand meeting Ford specifications) for your engine application.

Checking and Adding Engine Oil

Since the proper amount of engine oil is important for safe engine operation, check the oil using the dipstick each time you put fuel in your vehicle. Remember the engine must be off, the oil must be warm and the vehicle must be parked on level ground.

Checking the engine oil level:

1. Turn the engine off after it has warmed up and allow a few minutes for the engine oil to drain back into the oil pan.
2. Set the parking brake, making sure the gearshift is securely latched in P (Park).
3. Open the hood. Protect yourself from engine heat.
4. Locate the engine oil dipstick (highlighted in yellow) and carefully pull it out of the engine.
5. Wipe the dipstick clean and put it back into position, making sure it is fully seated.

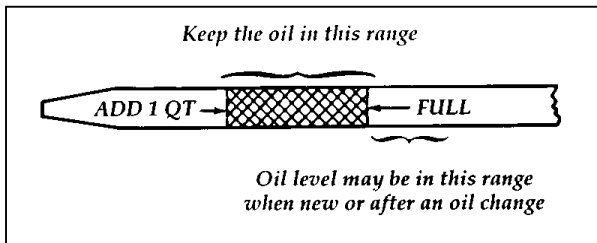

Engine oil dipstick

6. Carefully pull the dipstick out again. If the oil level is below the "ADD 1 QT" line, add engine oil as necessary. If the oil level is beyond the letter "F" in Full, engine damage or high oil consumption may occur and some oil must be removed from the engine.
7. Put the dipstick back in and make sure it is fully seated.

Adding engine oil

It may be necessary to add some oil between oil changes. Make sure you use a CERTIFIED engine oil of the preferred viscosity. Your vehicle's warranty coverage may not apply if engine damage is caused by the use of improper engine oil.

Add engine oil through the oil filler cap highlighted in yellow. To add oil, remove the filler cap and use a funnel to pour oil into the opening. Be careful not to overfill the engine. Recheck the oil level after you finish adding oil.

Engine Oil and Filter Changes

Change your engine oil and oil filter according to these mileage and time requirements, whichever occurs first.

5,000 MILES (8,000 KM) OR 6 MONTHS
NORMAL SCHEDULE

3,000 MILES (5,000 KM) OR 3 MONTHS
SEVERE DUTY SCHEDULE

EXTENSIVE IDLING
TRAILER TOWING
DRIVING IN SEVERE DUST
POLICE, TAXI, OR DELIVERY

Oil change intervals

Refer to the *Maintenance Schedule* booklet for additional information.

Brake Fluid

Your vehicle is equipped with a brake fluid level indicator in the master cylinder which lights the BRAKE warning light on the instrument panel when the brake fluid level is low.

Under normal circumstances, your vehicle should not use up brake fluid rapidly. However, expect the level of the brake fluid to slowly fall as you put more mileage on your vehicle and the brake pads wear.

Check the brake fluid at least once a year. You can do this by looking at the fluid level in the plastic brake fluid reservoir on the master cylinder. The fluid level should be at or near the MAX mark.

 **WARNING**

Brake fluid is toxic.

If brake fluid contacts eyes, flush eyes with running water for 15 minutes. Get medical attention if irritation persists. If taken internally, drink water and induce vomiting. Get medical attention immediately.

If the fluid is low, carefully clean and remove the filler cap from the reservoir. Fill the reservoir to the MAX line with Ford High Performance DOT 3 Brake Fluid C6AZ-19542-AB or DOT 3 equivalent fluid meeting Ford specification ESA-M6C25-A.

NOTE: If brake fluid is spilled on painted surfaces, it must be flushed and wiped away immediately. Brake fluid may dissolve the paint finish on your vehicle.

⚠ WARNING

If you use a brake fluid that is not DOT 3, you will cause permanent damage to your brakes.

Do not fill the reservoir above the MAX line.

If you find that the fluid level is excessively low — below the seam or ridge on the outside of the plastic reservoir — have the brake system inspected.

⚠ WARNING

Do not let the reservoir for the master cylinder run dry. This may cause the brakes to fail.

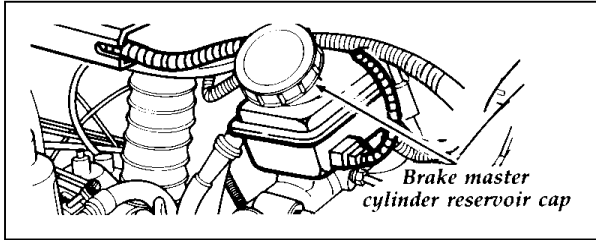

Brake master cylinder reservoir

Windshield Washer Fluid

Check the level of the windshield washer fluid every time you stop for fuel. The reservoir for the windshield washer fluid is located in the engine compartment.

⚠ WARNING

Do not put windshield washer fluid in the container for the engine coolant.

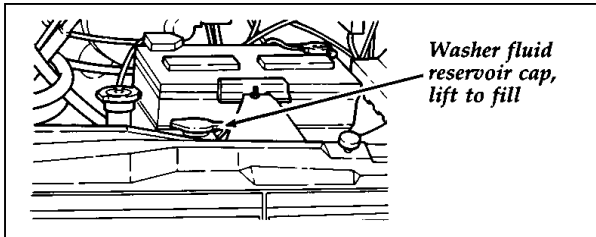

Windshield washer reservoir

Use specially formulated windshield washer fluid rather than plain water, because specially formulated washer fluids contain additives that dissolve road grime. For safety reasons, washer fluids containing an appropriate antifreeze such as methanol should be used in freezing weather (temperatures below 32°F [0°C]). State or local regulations on Volatile Organic Compounds (VOCs) may restrict use of the most common antifreeze, methanol. Washer fluids containing non-methanol antifreeze agents should be used only if they provide cold weather protection without damaging the vehicle's paint finish, wiper blades, and windshield washer system.

If you choose to use a windshield washing solution that must be mixed, follow the manufacturer's mixing instructions. Improperly mixed solutions may freeze unexpectedly.

⚠ WARNING

Windshield washer fluid contains methanol which is poisonous.

Checking/ladding the washer fluid for the liftgate

Check the liftgate washer reservoir regularly. This is not the same reservoir your front windshield wipers use. The opening for this reservoir is on the right side of the liftgate above the tail lamp. A fill cup is located on top of the right hand tail lamp and is accessible when the liftgate is open. Close the fill cup cover after filling and before closing the liftgate. Refill this reservoir with the same solution you use for your windshield. To find out how much washer fluid the liftgate reservoir holds, see *Refill capacities* in the Index.

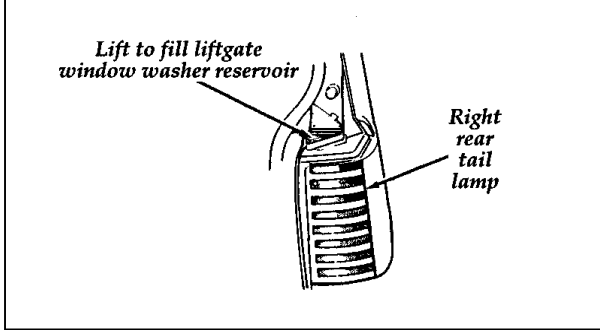

Liftgate window washer reservoir

Engine Coolant

Checking the Engine Coolant

NOTE: Be sure to read and understand *Precautions When Servicing Your Vehicle* at the beginning of this chapter.

Your vehicle's engine coolant protects the engine from overheating in the summer and from freezing in the winter. Check the level of the engine coolant at least once a month, but preferably each time you stop for fuel. Simply look at the engine coolant recovery reservoir located in the engine compartment. To locate this reservoir, see the diagram of your vehicle's engine under *Engine Compartment* in the *Capacities and Specifications* chapter.

Adding Engine Coolant

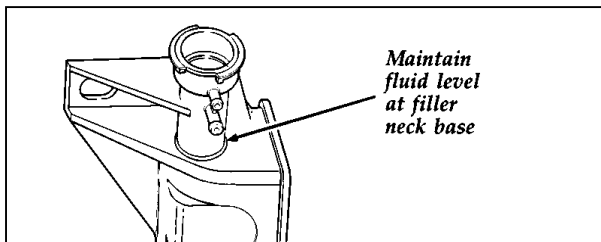

Adding engine coolant to reservoir

⚠ WARNING

Do not put engine coolant in the container for the windshield washer fluid.

When the engine is cool, add a 50/50 mixture of engine coolant and water to the engine coolant recovery reservoir — **DO NOT ADD DIRECTLY TO THE RADIATOR.** Add straight water only in an emergency, but you should replace it with a 50/50 mixture of coolant and distilled water as soon as possible.

Check the coolant level in the coolant recovery reservoir the next few times you drive the vehicle. If necessary, add enough of a 50/50 mixture of coolant and water to bring the liquid level to the fill line on the reservoir.

⚠ WARNING

Never remove the coolant recovery cap while the engine is running or hot.

If you must remove the coolant recovery cap, follow these steps to avoid personal injury caused by escaping steam or engine coolant:

1. **Before you remove the cap, turn the engine off and let it cool.**
2. **When the engine is cool, wrap a thick cloth around the cap and turn it slowly, counterclockwise to the first stop.**
3. Step back while the pressure releases.
4. When you are sure that all the pressure has been released, use the cloth to press the cap down, turn it counterclockwise, and remove it.

Use Ford Premium Engine Coolant E2FZ-19549-AA (in Canada, Motorcraft CXC-8-B) or an equivalent premium engine coolant that meets Ford specification ESE-M97B44-A. Ford Premium Engine Coolant is an optimized formula that will protect all metals and rubber elastomers used in Ford cooling systems for 4 years or 50,000 miles (80,000 km).

Do not use alcohol or methanol antifreeze or any engine coolants mixed with alcohol or methanol antifreeze. Do not use supplemental coolant additives in your vehicle. These additives may harm your engine cooling system. *The use of an improper coolant may void the warranty of your vehicle's engine cooling system.*

Recycled engine coolant

Ford Motor Company recommends that Ford and Lincoln-Mercury dealers use recycled engine coolant produced by Ford-approved processes. Not all coolant recycling processes produce coolant which meets Ford specification ESE-M97B44-A, and use of such coolant may harm engine and cooling system components.

Always dispose of used automotive fluids in a responsible manner. Follow your community's regulations and standards for recycling and disposing of automotive fluids.

Coolant refill capacity

To find out how much fluid your vehicle's cooling system can hold, refer to *Refill capacities* in the *Capacities and specifications* chapter.

Have your dealer check the engine cooling system for leaks if you have to add more than a quart (liter) of engine coolant per month.

Severe winter climate

If you drive in extremely cold climates (less than -34°F (-38°C), it may be necessary to increase the coolant concentration above 50%. Refer to the chart on the coolant container to ensure the coolant concentration in your vehicle is such that the coolant will not freeze at the temperature level in which you drive during winter months. Never increase the engine coolant concentration above 60%. Leave a 50/50 mixture of engine coolant and water in your vehicle year-round in non-extreme climates.

Checking Hoses

Inspect all engine and heater system hoses for deterioration, leaks and loose clamps before adding or replacing engine coolant. Make whatever repairs or replacements that are necessary using Motorcraft parts or their equivalents.

Engine Coolant Drain and Flush

Proper procedures for flushing the cooling system can be found in the *Service Manual*, or you can see a qualified technician.

NOTE: Due to air being trapped in the 4.0L engine cooling system, it is not unusual to experience a 4 to 7 ounce (120 to 210 ml) coolant loss up to 7,500 miles (12,000 km) after initial system fill.

Power Steering Fluid

Check the level of the power steering fluid at least twice a year (i.e., every Spring and Fall).

Checking and Adding Power Steering Fluid

1. Start the engine and let it run until the power steering fluid reaches normal operating temperature. The power steering fluid will be at the right temperature when the engine coolant temperature gauge in the instrument cluster is near the center of the NORMAL operating temperature range.
2. While the engine idles, turn the steering wheel back and forth several times. Make sure that the cap assembly is installed at this time.
3. Turn the engine off.
4. Check the fluid level on the dipstick (which is highlighted in yellow in your vehicle). The fluid level should be between the arrows in the FULL HOT range, which is marked on the side of the dipstick, opposite the side marked FULL COLD. Do not add fluid if the level is within the FULL HOT range.

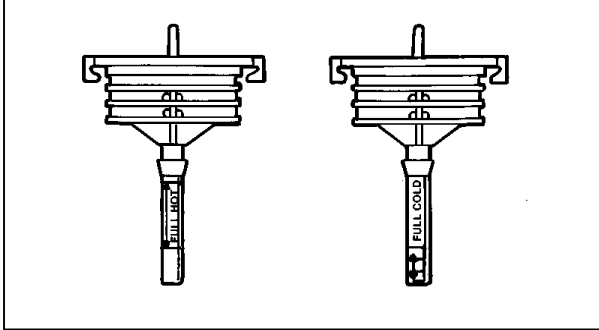

Power steering dipstick

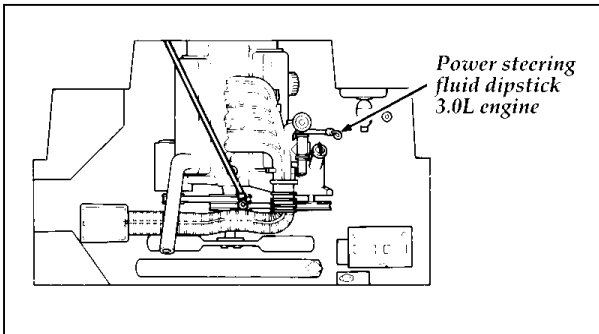

Power steering reservoir

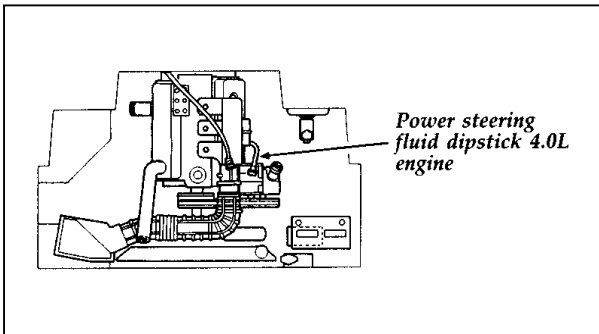

Power steering reservoir

5. If the power steering fluid is low, add fluid in small amounts, continuously checking the level, until you reach the FULL HOT range. Do not overfill.
6. When you are finished, put the dipstick back in and make sure that it fits snugly.

Use only a power steering fluid such as Ford Power Steering Fluid Motorcraft MERCON® ATF.

If the power steering fluid is low, do not drive your vehicle for a long period of time before adding fluid. This can damage the power steering pump.

If you check the power steering fluid when it is cold, make sure that the fluid reaches the FULL COLD range on the dipstick. The reading will only be accurate if the fluid temperature is approximately 50 to 85°F (10 to 30°C).

NOTE: Do not turn the steering wheel of your vehicle with the engine off. It could force power steering fluid out from the reservoir cap or in extreme cases, it could unseat the cap.

Automatic Transmission Fluid

Under normal driving conditions automatic transmission fluid should be changed every 30,000 miles (48,000 km) or 21,000 miles (34,000 km) if under severe duty conditions. However, if the transmission is not working properly, for instance, the transmission may slip or shift slowly, or you may notice some sign of fluid leakage, the fluid level should be checked.

It is preferable to check the transmission fluid level at normal operating temperature, after approximately 20 miles (30 km) of driving. However, if necessary, you can check the fluid

level without having to drive 20 miles to obtain a normal operating temperature if outside temperatures are above 50°F (10°C).

NOTE: If the vehicle has been operated for an extended period at high speeds or in city traffic during hot weather, or pulling a trailer, the vehicle should be turned off for about 30 minutes to allow the fluid to cool before checking.

Checking the Automatic Transmission Fluid

With the vehicle on a level surface, start the engine and move the gearshift lever through all of the gear ranges allowing sufficient time for each position to engage. Securely latch the gearshift lever in the P (Park) position, fully set the parking brake and leave the engine running.

| |
|--------------------------------------------------------------------------------------------------|
|  WARNING |
|--------------------------------------------------------------------------------------------------|

| |
|-------------------------------------------------------------------------------------------------------------------------------------------------------------|
| <p>Your vehicle should not be driven if the fluid level is below the bottom hole on the dipstick and outside temperatures are above 50°F (10°C).</p> |
|-------------------------------------------------------------------------------------------------------------------------------------------------------------|

Wipe off the dipstick cap (located toward the passenger's side of the engine), pull the dipstick out and wipe the indicator end clean. Put the dipstick back into the filler tube and make sure it is fully seated. Pull the dipstick out and read the fluid level.

When checking fluid at normal operating temperature, the fluid level should be within the crosshatched area on the dipstick. When the vehicle has not been driven, and outside temperature is above 50°F (10°C), the fluid level should be between the holes on the dipstick.

Adding Automatic Transmission Fluid

The fluid type is stamped on the dipstick.
Before adding any fluid, be sure that the correct type will be used.

Add fluid in 1/2 pint (.25L) increments through the filler tube to bring the level to the correct area on the dipstick. If an overfill occurs, excess fluid should be removed by a qualified technician.

NOTE: Always dispose of used automotive fluids in a responsible manner. Follow your community's standards for disposing of these types of fluids. Call your local recycling center to find out about recycling automotive fluids.

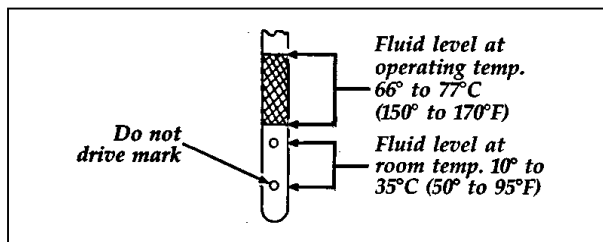

Automatic transmission dipstick

Driveline Universal Joint and Slip Yoke

The universal joints that come standard with your vehicle do not require lubrication. If your original equipment universal joints are replaced with universal joints equipped with grease fittings, lubrication will be necessary at the intervals shown in the *Maintenance Schedule* booklet.

Battery

Your vehicle may have a Motorcraft maintenance-free battery. The Motorcraft maintenance-free battery does not require additional water during its life of service. The vents are part of the cover and cannot be removed. For longer, trouble-free operation, keep the top of the battery clean and dry. Also, make certain the battery cables are tightly fastened to the battery terminals.

If you see any corrosion on the battery cables or terminals, remove the cables from the terminal and clean them both with a wire brush. You can neutralize the acid with a solution of baking soda and water. Reinstall the cables when you are done cleaning them, and apply a small quantity of grease to the top of each battery terminal to help prevent corrosion.

Battery replacement

If your original equipment battery requires replacement (under warranty), it may in some cases be replaced by a Motorcraft low-maintenance battery. The low-maintenance battery has removable vent caps for checking the electrolyte level and for adding water, if needed.

Check your battery's electrolyte level, at least every 12 months or 12,000 miles (20,000 km), in temperatures up to 90°F (32°C) and more often in temperatures above 90°F (32°C). Keep the electrolyte in each cell up to the "level" indicator. Do not overfill the battery cell.

If the electrolyte level in your battery gets low, you can add plain tap water to the battery, as long as you don't use hard water, or water with a high mineral or alkali content. If possible, however, try to only fill the battery cell with distilled water. If the battery needs water often, have the charging system checked.

Help Us Protect Our Environment

Ford Motor Company strongly recommends that used lead-acid batteries be returned to an authorized recycling facility for disposal.



Battery recycling symbol

Because your vehicle's engine is electronically controlled by a computer, some control conditions are maintained by power from the battery. If you ever disconnect the battery, install a new battery, or experience a dead battery you must allow the computer to "relearn" its idle conditions before your vehicle will drive properly. To let the engine do this, put the gearshift in P (Park), turn off all the accessories, and start the vehicle. Let the engine idle for at least one minute.

If you do not let the engine relearn its idle, the idle quality of your vehicle may be adversely affected until the idle is relearned. Your vehicle will eventually relearn its idle while you drive it, but it takes much longer than if you use the previous procedure.

WARNING

Batteries normally produce explosive gases which can cause personal injury. Do not allow flames, sparks or lit tobacco to come near the battery. Always cover your face and protect your eyes and also provide ventilation.

⚠ WARNING

Batteries contain sulfuric acid which burns skin, eyes, and clothing.

If the acid touches someone's skin, eyes, or clothing, immediately flush the area with water for at least 15 minutes. If someone swallows the acid, have him or her drink lots of milk or water first, then Milk of Magnesia, a beaten egg, or vegetable oil. Call a doctor immediately.

⚠ WARNING

Applying too much pressure on the ends when lifting a battery could cause acid to spill. Lift the battery with a carrier or with your hands on the opposite corners.

Wiper Blades

Check the windshield wiper blades at least twice a year. Also check them whenever they seem less effective than usual. Substances such as tree sap and some hot wax treatments used by commercial car washes reduce the effectiveness of wiper blades.

If the blades do not wipe properly, clean both the windshield and the wiper blades. Use undiluted windshield washer solution or a mild detergent. Rinse thoroughly with clear water. Do not use fuel, kerosene, paint thinner, or other solvents to clean your wiper blades. These will damage your blades.

To make reaching the wiper blades easy, simply turn the ignition to the ACC position and turn your wipers on. Wait for them to reach a vertical position and turn the ignition to the OFF position. Do not move the wipers manually. Manually moving the wipers across the windshield may damage them.

Wiper blade replacement

If the wiper blades still do not work properly after you clean them, you may need to replace the wiper blade assembly or the blade element. When replacing the wiper blade assembly, blade refill, or wiper arm always use a Motorcraft part or equivalent. To replace the blades, follow the instructions that come with them.

Tires

Look at your tires each time you fill your fuel tank. If one tire looks lower than the others, check the pressure in all of them. Always follow these precautions:

- Use an accurate tire pressure gauge.
- Check the tire pressure when tires are cold, after the vehicle has been parked for at least one hour or has been driven less than 3 miles (5 km).
- Make sure the weight of your load is evenly distributed.
- Adjust tire pressure to recommended specifications found on the Safety Compliance Certification Label.
- Make sure the spare tire is mounted and anchored properly in the tire carrier without contacting functional parts such as brake tubes, fuel lines, exhaust pipes, etc.

If you do not take these precautions, your tires may fail or go flat.

Ford Motor Company recommends obeying posted speed limits.

⚠️ WARNING

Driving too fast for conditions creates the possibility of loss of vehicle control. Driving at very high speeds for extended periods of time may result in damage to vehicle components.

At least once a month, check the pressure in all your vehicle's tires, including the spare. Use an accurate tire pressure gauge. Check the tire pressure when tires are cold, after the vehicle has been parked for at least one hour or has been driven less than 3 miles (5 km). You can find proper cold pressure and load limits of recommended size tires on the Safety Compliance Certification Label.

⚠️ WARNING

Improperly inflated tires can affect vehicle handling and can fail suddenly, possibly resulting in loss of vehicle control.

Tire Inspection and Maintenance

Inspect the tire treads, and remove stones, nails, glass or other objects that may be wedged in the tread grooves. Check for holes or cuts that may permit air to leak from the tire, and make the necessary repairs.

Inspect the tire side walls for cuts, bruises and other damage. If you suspect internal damage to the tire, have it demounted and checked. You may need to repair or replace it.

Wheel inspection and maintenance

Check for damage that would affect the runout of the wheels. Wobble or shimmy will eventually damage the wheel bearings.

Front wheel bearings require periodic repacking and adjustment as specified in the *Maintenance Schedule* booklet. Loose or worn front wheel bearings tend to let the vehicle wander or shimmy, and can eventually cause excessive tire wear.

Whenever a wheel is removed and then re-installed, always remove any corrosion that may be present on the mounting surface of the wheel and/or the surface of the hub, drum or rotor that contacts the wheel.

⚠ WARNING

Installing wheels without a good metal-to-metal contact at the wheel mounting surface can cause the wheel lug nuts to loosen and could allow the wheel to come off while the vehicle is in motion.

⚠ WARNING

On-vehicle wheel balancing will cause damage to the drivetrain of E-4WD Aerostars.

Traction-Lok Rear Axle (If equipped)

This axle provides added drive away traction on slippery surfaces, particularly when one or more wheels are on a surface with poor traction.

⚠ WARNING

To avoid injury, never run the engine with one wheel off the ground, such as when changing a tire.

Tire Rotation

Because your vehicle's front and rear tires perform different jobs, they often wear differently. To make sure your tires wear evenly and last longer, rotate them as indicated in the following diagram.

For tire rotation intervals, see the *Maintenance Schedule* booklet. If you notice that the tires wear unevenly, have them checked.

In situations where the tires differ from front to rear (snow/traction), simply rotate using a side to side pattern.

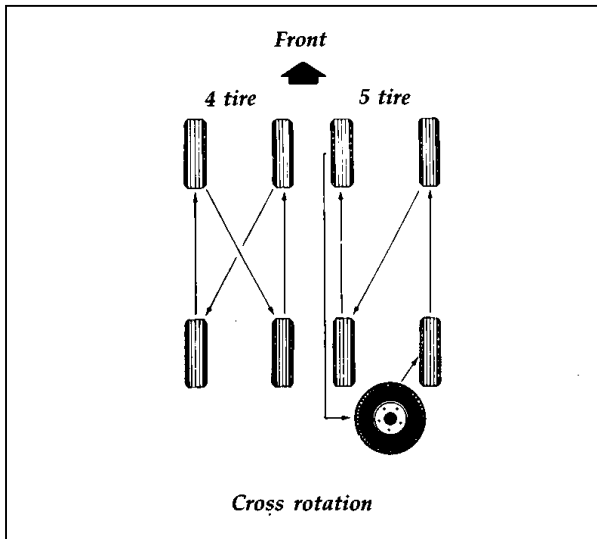

Tire rotation pattern

After each rotation, adjust individual tire pressure as specified on the Safety Compliance Certification Label. Tighten wheel lug nuts to the required torque specification and retighten again after 500 miles (800 km).

If your vehicle has aluminum wheels, you may demount the full size, non-temporary spare tire (if so equipped) and remount on an aluminum wheel to rotate the spare tire into your vehicle's rotation pattern. Rebalance the wheel.

You may discover uneven outside shoulder wear on your vehicle's front radial tires if you drive often in the city and turn frequently around curbs. You can extend the life of your front tires by remounting them so the outside of the tire faces inside on the wheel rim.

Replacing the Tires

Replace any tires that show wear bands. When your tire shows a wear band, it has only 1/16 inch (2 mm) of tread left.

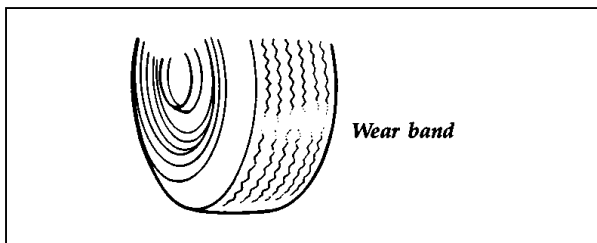

Wear band

Because your vehicle's tires may wear unevenly, you may need to replace them before a wear band appears across the entire tread.

Your wheels and tires are match-mounted for improved ride. Before you begin to repair a tire, mark the wheel and tire so that they are properly aligned when remounted. This will ensure that the tires will continue to give you the same ride level.

⚠️ WARNING

When replacing full size tires, never mix radial, bias-belted, or bias-type tires. Use only the tire sizes that are listed on the tire pressure decal. Make sure that all tires are the same size, speed rating, and load-carrying capacity. Use only the tire combinations recommended on the decal. If you do not follow these precautions, your vehicle may not drive properly and safely.

⚠️ WARNING

Make sure that all replacement tires are of the same size, type, load-carrying capacity, and tread design (e.g. "All Terrain", etc.), as originally offered by Ford.

⚠️ WARNING

Do not replace your tires with "high performance" tires or larger size tires.

⚠️ WARNING

Failure to follow these precautions may adversely affect the handling of the vehicle and make it easier to lose control and roll over.

Tires that are larger or smaller than your vehicle's original tires may also affect the accuracy of your speedometer.

Please note that the size in the following chart is typical. To determine what specific size tire and rim is recommended by Ford for use on your vehicle, refer to the Safety Compliance Certification Label on your vehicle.

Tire Size Designation

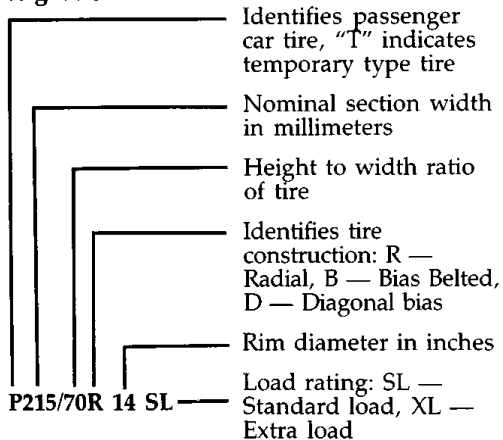

Tire identification chart

WARNING

Use of aftermarket wheel assemblies may damage your vehicle or cause accidents resulting in serious injuries.

Wheel and Tire Matching

See an authorized tire dealer for proper servicing procedures. Wheels and tires must be properly removed, matched and remounted to maintain the best possible ride.

Snow Tires and Chains

The tires on your vehicle have all-weather treads that provide traction in rain or snow. However, during the winter months in some climates, you may need to use snow tires and occasionally chains for your tires.

| |
|--------------------------------------------------------------------------------------------------|
|  WARNING |
|--------------------------------------------------------------------------------------------------|

| |
|----------------------------------------------------------------------------------------------------|
| Snow tires must be the same size and grade as the tires you currently have on your vehicle. |
|----------------------------------------------------------------------------------------------------|

Do not use chains when using a temporary spare. For full size tires, use chains on the tires only in an emergency or if the law requires them where you live. When you use the tire chains:

- Make sure the chains are the right size for your tires. Use only SAE Class "S" chains. Other types may damage your vehicle.
- Tire chains may scratch or chip aluminum wheels. IT IS RECOMMENDED THAT TIRE CHAINS ARE INSTALLED ON STEEL WHEELS ONLY. Be sure to remove wheel covers (if equipped) from steel rims before using tire chains to avoid scratches or damage.
- Local regulations may prohibit or restrict the use of tire chains. Investigate the laws and regulations in your area before installing chains.

- Put the chains on tightly with the ends held down securely. Verify that no chain touches any wiring, brake lines or fuel lines. Retighten the chains after driving 1/2 mile (0.8 km). Follow the chain manufacturer's instructions.
- Do not drive faster than 30 mph (48 km/h) or the chain manufacturer's recommended speed limit, whichever is lower. Avoid bumps, holes and sharp turns. If you can hear the chains rub or bang against your vehicle, remove the chains to prevent damage to your vehicle.
- Tire chains may affect vehicle handling. Drive carefully and avoid hard braking.
- Avoid fully loading your vehicle if possible.
- Remove tire chains at the first opportunity after using them on snow and ice. Do not use the chains on dry roads.
- Make sure your suspension insulation and bumpers are not missing or worn to avoid damage to your vehicle.

Filling the Fuel Tank

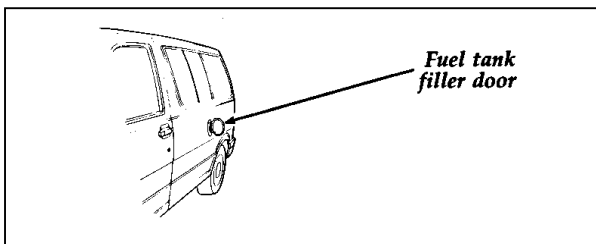

Fuel filler door

Opening the Fuel Filler Door

Fuel filler door remote release

To open the fuel filler door latch, pull on the release lever located between the driver's seat and the door. You cannot open the fuel filler door by pulling on the door itself.

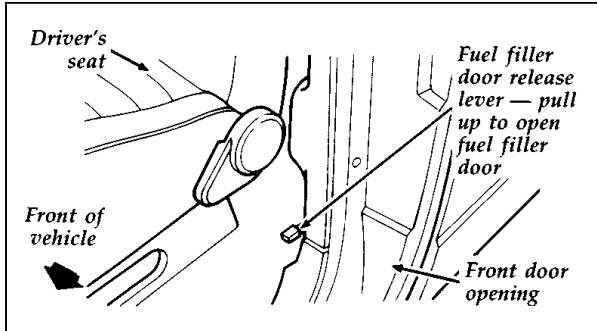

Fuel filler door remote release lever

If the release lever is stuck or damaged and you cannot open the fuel filler door, you must use the override cord located at the back of the left rear wheelhouse. (On extended versions the release lever is located in the stowage box.)

The manual release cord is attached to a T handle marked FUEL FILLER DOOR RELEASE — MANUAL OVERRIDE. When you pull it, the fuel filler door opens.

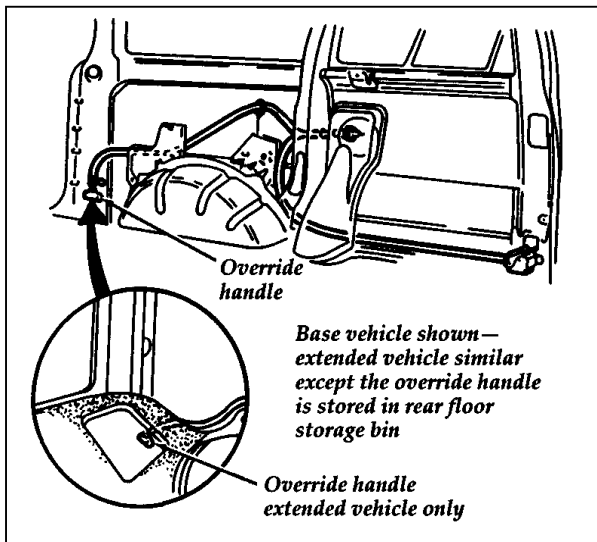

Fuel filler door override handle

Removing the fuel cap

The proper instructions for removing the fuel cap are as follows:

- Unscrew the fuel cap by exerting pressure on the plastic lock bar and rotating the fuel cap counterclockwise.
- Turn the fuel cap 1/2 to 3/4 of a turn until a hissing sound is heard. When the hissing sound stops, continue rotating counterclockwise to remove the fuel cap.
- Make sure that you follow the above fuel cap removal instructions and use caution. Such caution will minimize the possibility of fuel spraying during removal of the fuel cap.

To replace and secure the fuel cap, place it in position and rotate it clockwise until it clicks (ratchets). Doing so will not damage or break

the fuel cap. The ratcheting mechanism allows the fuel cap to be sealed without overtightening.

If you lose the fuel cap, replace it with an authorized Motorcraft or equivalent part.

⚠ WARNING

If you do not use the proper fuel cap, the pressure in the fuel tank can damage the fuel system or cause it to work improperly in a collision.

NOTE: If you replace your fuel cap with an aftermarket fuel filler cap, the customer warranty may be void for any damage to the fuel tank and/or fuel system.

⚠ WARNING

The fuel system may be under pressure. If the fuel cap is venting vapor or if you hear a hissing sound, wait until it stops before completely removing the cap.

A venting fuel tank is not an abnormal condition. It may be caused by:

- Too volatile a fuel for the weather conditions.
The service stations sometimes sell winter grade fuel in the summer.
- Pulling a heavy load on hot days, or at high altitudes.
- Extended periods of idling with the engine RPM increased above the normal idle range.
- Parking vehicle in full sunlight for extended periods on extremely hot days.

Choosing the Right Fuel

Use only UNLEADED FUEL. The use of leaded fuel is prohibited by law and could damage your vehicle. The damage may not be covered by your warranty.

Your vehicle was not designed to use fuel containing manganese-based additives such as MMT. Additionally, vehicles certified to California emission standards (indicated on the underhood Vehicle Emissions Control Information label) are designed to operate on California reformulated gasolines. If California reformulated gasoline is not available when you refuel, your vehicle can be operated on non-California fuels. However, even though your engine will perform adequately on other gasolines, the performance of the emission control devices and systems may be adversely affected. Repair of damage caused by using a fuel that your vehicle was not designed for may not be covered by your warranty.

Octane recommendation

Your vehicle is designed to use regular gasoline with an (R+M)/2 octane rating of 87. We do not recommend gasolines labeled as “regular” in high altitude areas that are sold with octane ratings of 86 or even less.

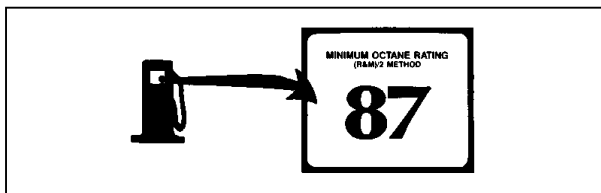

Typical octane rating label

Do not be concerned if your vehicle sometimes knocks lightly. However, if it knocks heavily under most driving conditions on the recommended octane fuel, see your dealer or a qualified service technician to prevent any engine damage.

Fuel quality

If you are experiencing starting, rough idle or hesitation problems, try a different brand of fuel. If the condition persists, see your dealer or a qualified service technician.

The American Automobile Manufacturers Association (AAMA) issued a gasoline specification to provide information on high quality fuels that optimize the performance of your vehicle. We recommend the use of gasolines that meet the AAMA specification if they are available.

It should not be necessary to add any aftermarket products to your fuel tank if you continue to use a high-quality fuel.

Gasolines for clean air

Ford approves the use of gasolines to improve air quality, including reformulated gasolines that contain oxygenates such as a maximum of 10% ethanol or 15% MTBE. There should be no more than 5% methanol with cosolvents and additives to protect the fuel system.

Safety Information Relating to Automotive Fuels

| |
|----------------------------------------------------------------------------------------------------|
|  WARNING |
| Automotive fuels can cause serious injury or death if misused or mishandled. |

- Turn vehicle off when refueling.

- Do not smoke when refueling. Fuels are extremely flammable.
- Do not siphon any fuel by mouth.

⚠ WARNING

Gasoline or gasoline blended with methanol can cause blindness and possible death when swallowed. If any fuel is swallowed, call a physician or poison control center immediately.

- Avoid breathing vapors while refueling.
- If fuel is splashed on the skin, wash with soap and water.
- If fuel is splashed in the eyes, remove contact lenses (if worn), flush with water for 15 minutes, and seek medical attention.

Gasoline and gasoline blends may contain small amounts of carcinogens, such as benzene. Long-term exposure to unleaded gasoline vapors has caused cancer in laboratory animals.

If you are taking the medication “Antabuse” or other forms of disulfiram for the treatment of alcoholism, vapor or skin contact with a gasoline-methanol blend may cause the same kind of adverse reaction as drinking an alcoholic beverage. In sensitive individuals, serious personal injury or sickness could result. Consult a physician promptly if you experience an adverse reaction.

Filling the fuel tank

⚠ WARNING

Do not overfill the fuel tank. The pressure in an overfilled tank may cause leakage and lead to fuel spray and fire.

To fill the fuel tank properly:

NOTE: Extinguish all lit cigarettes, other smoking materials, and any open flames before fueling your vehicle.

1. Remove the fuel cap by following the instructions above under *Removing the Fuel Cap* in this chapter. Proceed to add fuel to the tank only if your vehicle is on level ground.
2. Make sure that you pump unleaded fuel and put the nozzle all the way inside the fuel filler pipe.
3. If you spill any fuel on the body of your vehicle, clean it off immediately. The fuel may dull or soften the paint if you do not wash it off.
4. Replace the fuel cap completely when you are finished. Turn it clockwise until it is fully tight. It will click when it is fully tightened.

You may occasionally hear and/or feel a slight thump occurring one or two seconds after a gentle stop. This is normal and generally occurs with the fuel tank 3/4 full. It is caused by the wave action of the fuel within the tank.

Running Out of Fuel

If your vehicle runs out of fuel, try to stop on level ground away from traffic. Add at least two gallons (8 liters) of fuel to start your vehicle again. If your vehicle is not on level ground, you may need as much as five gallons (20 liters) of fuel to start it.

NOTE: Avoid running out of fuel because this situation may have an adverse effect on modern powertrain components.

You may need to crank the engine several times before the fuel system starts to pump fuel from the tank to the engine.

Fuel Economy

Fuel economy is an estimate of the efficiency of your vehicle and can be calculated as Miles Per Gallon (MPG) or Liters Per 100 Kilometers (L/100K). Do not calculate the fuel economy during your vehicle's break-in period. This would not be an accurate estimate of how much fuel your vehicle will normally use.

To calculate fuel economy:

1. Fill the tank completely and record the initial odometer reading.
2. Every time you buy fuel record the amount (in gallons or liters) purchased.
3. After at least three to five tankfuls, fill the fuel tank and record the final odometer reading.
4. Use these equations to calculate your fuel economy:

English: $\text{MPG} = (\text{total miles driven}) \div (\text{gallons used})$

Metric: $\text{L}/100\text{k} = (100 \times \text{liters used}) \div (\text{total kilometers driven})$

Comparisons With Environmental Protection Agency (EPA) and Transport Canada (TC) Fuel Economy Estimates

EPA and TC fuel economy figures are obtained from laboratory tests under simulated road conditions and thus are estimates which may not reflect the actual conditions you experience or your personal style of driving. The EPA or TC fuel economy estimate is not a guarantee that you will achieve the fuel economy shown.

The following decrease fuel economy:

- Lack of regular, scheduled maintenance
- Excessive speed
- Rapid acceleration
- Driving with your foot on the brake
- Sudden stops
- Extended engine idling
- Using speed control in hilly terrain
- Extended use of the A/C, defroster, rear window defroster and other accessories
- Underinflated tires
- Heavy loads
- Aftermarket add-ons such as bike, ski or luggage racks, bug deflectors, etc.

Emission Control System

Your vehicle is equipped with a catalytic converter which enables your vehicle to comply with applicable exhaust emission requirements.

To make sure that the catalytic converter and the other emission control parts continue to work properly:

- Use only unleaded fuel.
- Avoid running out of fuel.
- Do not turn off the ignition while your vehicle is moving, especially at high speeds.
- Have the services listed in your *Maintenance Schedule* booklet performed according to the specified schedule.

⚠️ WARNING

Do not park, idle, or drive your vehicle in dry grass or other dry ground cover. The emission system heats up the engine compartment and exhaust system, which can start a fire.

⚠️ WARNING

On vehicles without original equipment floor covering or insulation, do not let passengers ride in your truck in a manner that allows contact between skin and the metal floor.

Watch for fluid leaks, strange odors, smoke, loss of oil pressure, the charge warning light, the check engine light, or the temperature warning light. These sometimes indicate that the emission system is not working properly.

Do not make any unauthorized changes to your vehicle or engine. Changes that cause more unburned fuel to reach the exhaust system can increase the temperature of the engine or exhaust system.

By law, anyone who manufactures, repairs, services, sells, leases, trades vehicles, or supervises a fleet of vehicles is not permitted to intentionally remove an emission control device or prevent it from working. In some of the United States and in Canada, vehicle owners may be liable if their emission control device is removed or is prevented from working.

Never use a metal exhaust collector when you service your vehicle. If the metal collector contacts any of your vehicle's plastic trim or bumper parts they could melt or deform.

Do not drive your vehicle if it does not operate properly. See your dealer if the engine runs on for more than five seconds after you shut it off or if it misfires, surges, stalls, or backfires.

Information about your vehicle's emission control system is on the Vehicle Emission Control Information decal located on or near the engine. This decal identifies engine displacement and gives some tune-up specifications.

How to Prepare Your Vehicle for Inspection/Maintenance (I/M) Testing

In some localities it may become a legal requirement to pass an Inspection/Maintenance (I/M) test of the On-Board Diagnostic (OBD) II system. If the vehicle's powertrain system or its battery has just been serviced, the OBD II system is reset to a not ready for I/M testing condition. To prepare for I/M testing, the law specifies that additional mixed city and highway driving is required to complete the check of the OBD II system.

The driving modes required to reach the ready condition consist of a minimum of 30 minutes of city and highway driving as described below:

- 20 minutes of driving in stop and go city-type traffic with at least four idle periods.
- 10 minutes of driving on an expressway or highway.

Before completing the above driving modes, the engine must be warmed up and at operating temperature. Once started, the vehicle must not be turned off during the above driving modes. If the vehicle owner is unable to meet the I/M requirements by using these driving patterns, an

authorized service center can perform a detailed OBD II drive cycle as it would any other type of repair work.

Lights and Bulb Replacement

It is a good idea to check the operation of the following lights frequently:

- headlamps
- high-mount brakelamp
- tail lamps
- brakelamps
- hazard flasher
- turn signals
- license plate lamps

The alignment of your headlamps should be checked if:

- oncoming motorists frequently signal you to turn off your vehicle's high beams when you do not have the high beams on
- the headlamps do not seem to give you enough light to see clearly at night
- the headlamp beams are pointed substantially away from a position slightly down and to the right

Headlamp Bulb

The headlamps on your vehicle use replaceable bulbs. When the lamp burns out, simply replace the bulb, rather than the whole lamp.

⚠ WARNING

Handle a halogen headlamp bulb carefully and keep out of children's reach. Grasp the bulb only by its plastic base and do not touch the glass. The oil from your hand could cause the bulb to break the next time the headlamps are operated.

NOTE: If the bulb is accidentally touched, it should be cleaned with rubbing alcohol before being used.

Do not remove the burned-out bulb unless you can immediately replace it with a new one. If a bulb is removed for an extended period of time, contaminants may enter the headlamp housing and affect its performance.

Removing the headlamp bulb

1. Make sure that the headlamp switch on the instrument panel is in the OFF position.
2. Remove the screws that attach the headlamp trim to the vehicle.
3. Remove the headlamp trim.
4. Remove the four screws (two on top and two on bottom) that attach the headlamp to the vehicle.

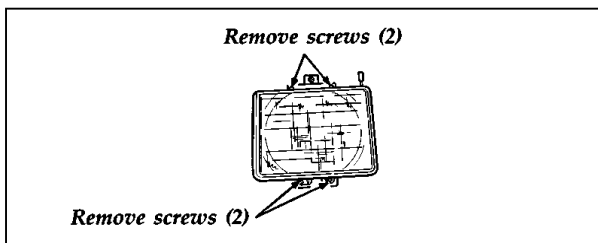

NOTE: Do not disturb the aim adjusting screws.

5. Pull the headlamp away from the vehicle and remove the electrical connector by pulling rearward.
6. Unsnap the bulb retaining wire and carefully remove the bulb assembly from its socket by gently pulling it out without turning it.

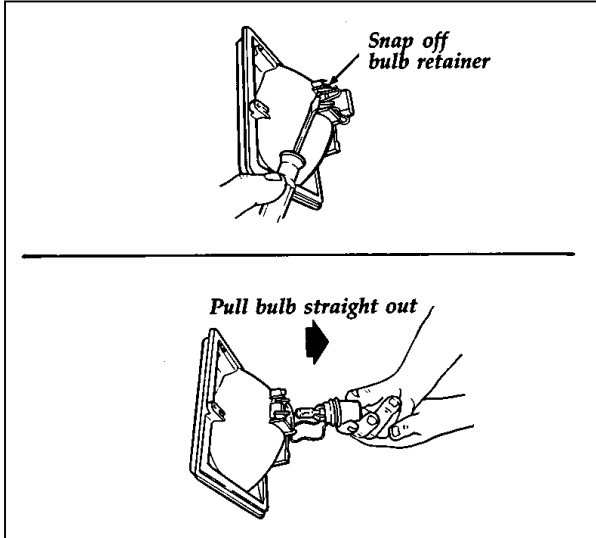

Installing the headlamp bulb

1. With the flat side of the bulb's plastic base facing upward, insert the glass end of the bulb into the socket. You may need to turn the bulb left or right to line up the grooves in the plastic base with the tabs in the socket. When the grooves are aligned, push the bulb into the socket until the plastic base contacts the rear of the socket.

2. Snap the retaining wire over both sides of the bulb and connect the electrical connector.
3. Position the headlamp on the vehicle and install the four attaching screws.
4. Turn the headlamps on and make sure that they work properly. If the headlamp was correctly aligned before you changed the bulb, you should not need to align it again.

Removing the High-Mount Brakelamp Bulb

Liftgate models

To remove the brakelamp and bulb:

1. Remove the two screws from the surface of the lens.
2. After removing the screws, remove the lamp assembly.
3. Disconnect the high-mount brakelamp wiring connector.
4. Remove the screw retaining the bulb holder assembly, pull the bulb holder assembly away from the lamp, and pull the bulb straight out of the holder.

To replace/install the brakelamp:

1. Push bulb(s) into bulb holder assembly.
2. Place bulb holder assembly on lamp and install retaining screw. Tighten screw.
3. Connect the high-mount brakelamp wiring connector.
4. Position the lamp assembly on the vehicle.
5. Install and tighten the two screws.

6. Apply brakes to confirm the brakelamp is functional after installing.

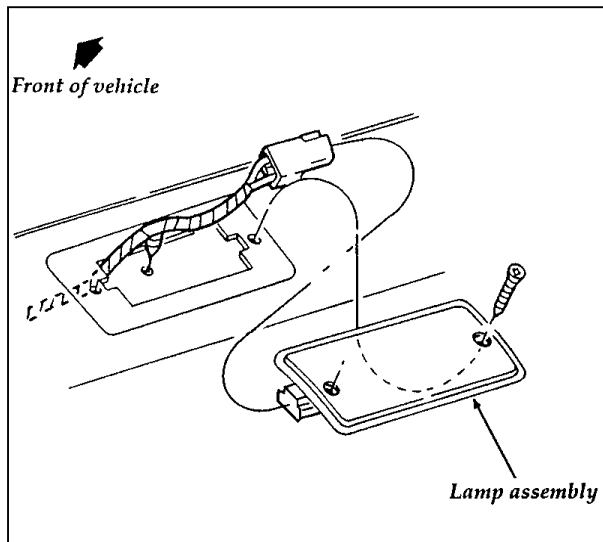

Replacing the high-mount brakelamp bulb — liftgate models only

Dual Rear Door Models

To remove the brakelamp:

1. Remove the two screws from the surface of the lens.
2. Pull the lens assembly out of the lamp housing.
3. Pull the bulb socket out of the lens assembly. It is not necessary to twist the socket.
4. Pull the bulb out of the socket.

To replace/install the brakelamp:

1. Push the bulb into the socket.
2. Push the socket into the lens assembly.

3. Install the lens assembly into lamp.
4. Install and tighten the two screws.

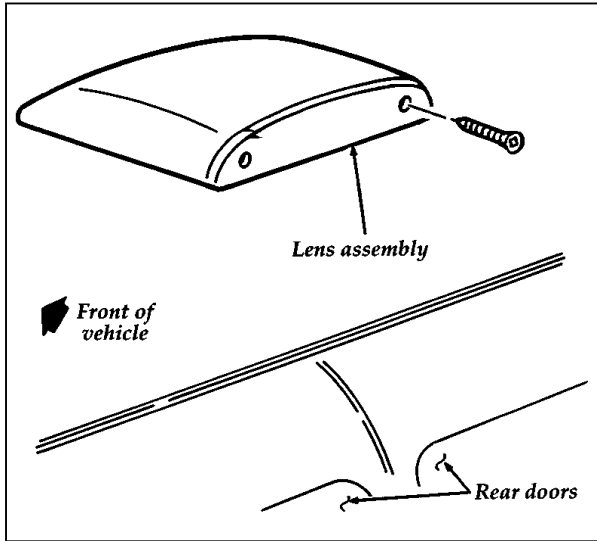

Replacing the high-mount brakelamp bulb — dual rear door models only

Bulb Specifications

| Description | No. of Lamps Req'd | Trade Number |
|-----------------------------------|--------------------|--------------|
| Front Lamps – Exterior | – | – |
| • Headlamps (Hi land Lo Beam) | 2 | 9007 |
| • Park, Turn & Side Marker | 2 | 3157NAK |
| • Stepwell Lamp | 1 | 168 |
| Rear Lamps – Exterior | – | – |
| • Backup | 2 | 3156K |
| • License Plate (Liftgate) | 2 | 168 |
| • License Plate (Dual Rear Door) | 1 | 168 |
| • Park, Brake & Side Marker, Turn | 2 | 3457K |
| • Cargo | 1 | 906 |
| • High-mount Brakelamp | | |
| – Liftgate Model | 2 | 912 |
| – Dual Rear Door Model | 1 | 921 |
| Interior Courtesy Lamps | – | – |
| • Dome | 1 | 211-2 |
| • Dome/Map Combination | 3 | 578 |
| • Instrument Panel | 2 | 89 |
| • Overhead Console Map Lamps | 2 | 912 |
| • Visor Vanity Mirror | 4 | 194 |
| Radio Illumination | – | – |
| • Remote Radio Control | 1 | 37 |
| • Radio Pilot Light | ① | ① |
| • Radio Illumination | ① | ① |
| • Graphic Equalizer | ① | ① |
| Instrument Panel | – | – |
| • Glove Compartment | 1 | 194 |
| • Ash Tray | 2 | 1892 |
| • Cigarette Lighter Ring | 1 | 161 |

① Refer bulb replacement to Ford authorized radio

| Description | No. of Lamps Req'd | Trade Number |
|-----------------------------------------------------------------------------------------------------------------------------------------------------------------------------------------------------------------------------------------------------------|------------------------------------------------------------------------|----------------------------------------------------------------------------------------------------|
| Instrument Cluster • General Illumination • Warning Lights: Rear Anti-Lock Brake Check Engine Charge System Electronic 4WD Air Bag Fasten Seat Belts High Beam Indicator Door Ajar • Turn Signal Indicator • PRNDL | 5 1 1 1 1 1 1 1 1 1 1 1 2 1 | 194 194 194 194 194 194 194 194 194 194 194 194 194 194 |
| Instrument Panel Controls • A/C or Heater Control Illumination • Rear Wiper/Wash Switch • Rear Defrost Switch | 2 ① ① | 161 — — |

① Refer service to Ford dealer.

Cleaning Your Vehicle

Washing and Polishing Your Vehicle

Wash the outside of your vehicle, including the underside, with a mild detergent.

DO NOT:

- Wash your vehicle with hot water
- Wash your vehicle while it sits in direct sunlight
- Wash your vehicle while the body is hot

Pollen, bird droppings and tree sap can damage the paint, especially in hot weather. Wash your vehicle as often as necessary to keep it clean.

Take similar precautions if your vehicle is exposed to chemical industrial fallout.

Paint damage resulting from fallout is not related to a defect in paint materials or workmanship and therefore is not covered by warranty. Ford, however, believes that continual improvement in customer satisfaction is a high priority. For this reason, Ford has authorized its dealers to repair, at no charge to the owner, the surfaces of new vehicles damaged by environmental fallout within 12 months or 12,000 miles (20,000 km) of purchase, whichever comes first. Customers may be required to bring their vehicle in for inspection by a Ford representative.

Polish your vehicle to remove harmful deposits and protect the finish.

Cleaning Chrome and Aluminum Parts

Wash chrome and aluminum parts with a mild detergent. Do not use steel wool, abrasive cleaners, fuel or strong detergents.

Cleaning Plastic Parts

Some of your vehicle's exterior trim parts are plastic. Clean with a tar and road oil remover if necessary. Use a vinyl cleaner for routine cleaning.

Do not clean plastic parts with thinners, solvents or petroleum-based cleaners.

If you have your vehicle rustproofed, remove oversprayed rustproofing with a tar and road oil remover. If rustproofing is not removed from plastic and rubber parts, it can cause deterioration.

Cleaning the Wheels

Wash the wheels with the same detergent you use to wash your vehicle's body. Do not use acid-based wheel cleaners, steel wool, abrasives, fuel, or strong detergents. These substances will damage protective coatings. Use tar and road oil remover to remove grease and tar.

NOTE: Before going to a car wash, find out if the brushes are abrasive.

If you have whitewall tires that are difficult to clean with regular detergent, use Ford Extra Strength Whitewall Tire Cleaner or equivalent. Follow the directions on the container and rinse the tires with plenty of clean water.

Cleaning the Exterior Lamps

Do not use dry paper towel, chemical solvents or abrasive cleaners to clean the lamps, as these may cause scratches or crack the lamps.

Cleaning the Engine

A clean engine is more efficient because a buildup of grease and dirt acts as an insulator, keeping the engine warmer than usual.

- Extreme care must be used if a power washer is used to clean the engine. The high pressure fluid could penetrate sealed parts and assemblies causing damage or malfunctions.
- In order to avoid possible cracking of the engine block, do not spray a hot engine with cold water.
- The alternator and air intake must be covered. Covering these components will help prevent water damage.
- Never wash or rinse the engine while it is running. Water getting into the engine may cause internal damage.

Cleaning the Instrument Panel Lens

Clean the instrument panel lens with a soft cloth and a glass cleaner, such as Ford Ultra-Clear Spray Glass Cleaner, or equivalent. Do not use paper towel or an abrasive cleaner to clean the lens as these may cause scratches.

Cleaning the Interior Lamps

Your interior dome lamps and map lamps are plastic and should be cleaned with a mild detergent diluted in water. Rinse them with clear water.

Cleaning the Seats

Vinyl

For routine cleaning, wipe the surface with a soft, damp cloth. For more thorough cleaning, wipe the surface with a leather and vinyl cleaner or a mild soap.

Fabric

Remove dust and loose dirt with a whisk broom or a vacuum cleaner. Remove fresh spots immediately. Follow the directions that come with the cleaner.

NOTE: Before using any cleaner, test it on a small, hidden area of fabric. If the fabric's color or texture is adversely affected by a particular cleaner, do not use it.

Cleaning the Built-In Child Seat (if equipped)

Your Built-In Child Seat may be cleaned with mild soap and water. Do not use household cleaners as they may weaken the webbing or damage the plastic parts. For your convenience, the liner can be removed, machine-washed, and air-dried.

Cleaning the Safety Belts

Clean the safety belts with any mild soap solution that is recommended for cleaning upholstery or carpets. Do not bleach or dye the belt webbing because this may weaken it.

Vehicle Storage

Maintenance Tips

If you plan on storing your vehicle for an extended period of time (60 days or more), refer to the following maintenance recommendations to ensure your vehicle stays in good operating condition.

General

- Store all vehicles in a dry, ventilated place.
- Protect from sunlight, if possible.
- If vehicles are stored outside, they require regular maintenance to protect against rust and damage.

Body

- Wash vehicle thoroughly to remove dirt, grease, oil, tar or mud from exterior surfaces, rear wheel housing and underside of front fenders.
- Periodically wash vehicles stored in exposed locations.
- Touch-up raw or primed metal to prevent rust.
- Cover chrome and stainless steel parts with a thick coat of auto wax to prevent discoloration. Re-wax as necessary when the vehicle is washed.
- Lubricate all hood, door and trunk lid hinges and latches with a light grade oil.
- Cover interior soft trim to prevent fading.
- Keep all rubber parts free from oil and solvents.

Engine

- Start engine every 15 days. Run at fast idle until it reaches normal operating temperature.
- With your foot on the brake, shift through all the gears while the engine is running.

Fuel system

- Fill fuel tank with high-quality unleaded fuel until the first automatic shutoff of the fuel pump nozzle.

NOTE: During extended periods of vehicle storage (60 days or more), fuel may deteriorate due to oxidation. This can damage rubber and other polymers in the fuel system and may also clog small orifices.

Ford Gas Stabilizer should be added whenever actual or expected storage periods exceed 60 days. Follow the instructions on the label. The vehicle should then be operated at idle speed to circulate the additive throughout the fuel system.

A volatile corrosion inhibitor added to the fuel system will protect the fuel system's inner surfaces from corrosion. Follow the instructions packaged with the product.

Cooling system

- Protect against freezing temperatures.

Battery

- Check and recharge as necessary.
- Keep connections clean and covered with a light coat of grease.

Brakes

- Make sure brakes and parking brake are fully released.

Tires

- Maintain recommended air pressure.

Miscellaneous

- Make sure all linkages, cables, levers and clevis pins under vehicle are covered with grease to prevent rust.
- Move vehicles at least 25 feet (8 m) every 15 days to lubricate working parts and prevent corrosion.

Ford Accessories for Your Vehicle

Ford has many fine products available from your dealer to clean your vehicle and protect its finishes. For best results, use the following, or products of equivalent quality:

- Ford Custom Clear Coat Polish
- Ford Custom Silicone Gloss Polish
- Ford Custom Vinyl Protectant
- Ford Deluxe Leather and Vinyl Cleaner
- Ford Extra Strength Spot and Stain Remover
- Ford Extra Strength Tar and Road Oil Remover
- Ford Extra Strength Upholstery Cleaner
- Ford Extra Strength Whitewall Tire Cleaner
- Ford Multi-Purpose Cleaner
- Ford Premium Car Wash Concentrate
- Ford Triple Clean
- Ford Ultra-Clear Spray Glass Cleaner

A wide selection of accessories is available through your local authorized dealer. These fine accessories have been engineered specifically to fulfill your automotive needs. They are custom designed to complement the style and aerodynamic appearance of your Ford-built vehicle. In addition, each accessory is made from high quality materials and meets or exceeds Ford's rigid engineering and safety specifications. That is why Ford brand accessories are warranted for up to 12 months or 12,000 miles (20,000 km), whichever comes first. See your dealer for complete warranty information and accessory availability.

Comfort and Convenience

Console/Storage and Beverage
Engine Block Heater

Protection and Appearance Equipment

Cargo Liner (Soft)
Cleaners
Floor Mats
Hood Deflector
Lubricants
Running Boards
Soft Luggage Cover
Super Seal Fabric Protector (U.S. only)
Super Seal Undercoating (U.S. only)
Touch-Up Paints
Waxes
Wheel Splash Guards
Side Window Deflectors
Door Edge Guards
Front End Cover

Safety Equipment

Anti-Theft Lug Nuts (Alum. Wheels only)
Vehicle Security System
Remote Keyless Entry

Travel Equipment

- Bike Adaptor for Clamp-on Rack
 - Water Sports Adaptor for Clamp-on Rack (canoe, kayak, surfboard)
- Cargo Retention Net
- Fog Lights
- Four Seasons Base Rack (Permanent Mount)
 - Bike Rack Adaptor (Permanent Mount)
 - Ski Rack Adaptor
- Speed Control
- Sportsrack – Roof Rack (Clamp-on)
- Ski Adapter for Clamp-on Rack
- Trailer Hitch (Class I and II)

NOTE: When adding accessories, equipment, passengers, and luggage to your vehicle, do not exceed the total weight capacity of the vehicle or of the front or rear axle (GVWR, GAWR as shown on the Safety Compliance Certification Label). Consult your dealer for specific weight information.

NOTE: The Federal Communications Commission (FCC) or the Canadian Radio Telecommunications Commission (CRTC) regulates the use of mobile communications systems — such as two-way radios, telephones, and theft alarms — that are equipped with radio transmitters. Any such equipment installed in your vehicle should comply with FCC or CRTC regulations and should be installed only by a qualified technician.

NOTE: Mobile communications systems may harm the operation of your vehicle, particularly if they are not properly designed for automotive use or are not properly installed. For example, when operated, such systems may cause the engine to stumble or stall. In addition, such systems may themselves be damaged or their operation affected by operating your vehicle. (Citizens band [CB] transceivers, garage door openers, and other transmitters whose power output is 5 watts or less will not ordinarily affect your vehicle's operation.)

NOTE: Because we have no control over the installation, design, or manufacture of such systems, Ford cannot assume responsibility for any adverse effects or damage that may result if you use this equipment.

**FOR INFORMATION ON
ORDERING SERVICE
PUBLICATIONS, CONTACT:**

**U.S. RESIDENTS
CALL
HELM, INCORPORATED
1-800-782-4356**

**Monday - Friday 8:00 A.M. - 6:30 P.M. EST
For Credit Card Holder Orders Only**

**CANADIAN RESIDENTS
CALL
Ford Motor Company of Canada, Ltd.
1-800-387-4966**

**Monday - Friday 8:00 A.M. - 6:30 P.M. EST
For Credit Card Holder Orders Only**

All rights reserved. Reproduction by any means, electronic or mechanical including photocopying, recording or by any information storage and retrieval system or translation in whole or part is not permitted without written authorization from Ford Motor Company.

Copyright © 1996 Ford Motor Company

Capacities and Specifications

Refill Capacities, Motorcraft Parts, and Lubricant Specifications

Motorcraft Parts

| ENGINE | 3.0L EFI | 4.0L EFI |
|-----------------------------------------------------------------------------------------------------------------------------------------------------------------------------------------------------------------------------------------------------------------------------------------------------------------------------------------------------------------------------------------------------------------------------|--------------------------|--------------------------|
| Spark Plug ① | AWSF-32PP ② | AGSF-22-P ② |
| Oil Filter | FL-400-S | FL-1A |
| Air Filter | FA-1043 | FA-1043 |
| Fuel Filter | FG-800A | FG-800A |
| Battery – Standard Optional | BXT-65-650 BXT-65-750 | BXT-65-650 BXT-65-750 |
| P.C.V. Valve | EV-130 | EV-118 |
| <p>① Refer to Vehicle Emission Control Information Decal for spark plug and gap specifications.</p> <p>② If a spark plug is removed for examination, it must be reinstalled in the same cylinder. Cylinders #1, #2, #3 have a PG suffix. Cylinders #4, #5, #6 have a P suffix. If a spark plug needs to be replaced, use only spark plugs with the service part number suffix letter "PP" as shown on the engine decal.</p> | | |

Fluid Specifications and Capacities

| Component | Capacities | |
|------------------------------------------------------------------------------------------------------------------------------------|--------------------------|--------------|
| | U.S. Measure | Liters |
| Engine Crankcase 3.0L (182 CID) V6 4.0L (245 CID) V6 ② | (Quarts) 4.5 5.0 | 4.2 4.7 |
| Front Axle (E-4WD) Dana Model 28-2 | (Pints) 2.2 | 1.0 |
| Transfer Case (E-4WD) Dana Model TC-28 | (Pints) 4.5 | 2.1 |
| Rear Axle ① Ford Conventional and Traction Lok 7.5" Ring Gear Ford Conventional and Traction Lok 8.8" Ring Gear | (Pints) 3.5 5.0 | 1.7 2.4 |
| Transmission – Automatic 4R44E/5R55E 5R55E E-4WD | (Quarts) 9.5 9.8 | 9.0 9.3 |
| Engine Coolant 3.0L V6 Gasoline 4.0L V6 Gasoline | (Quarts) 11.8 12.6 | 11.1 11.9 |
| Fuel Tank Wheelbase Midship 118.9" | (Gallons) 21.0 | 79 |
| Footnotes located at end of Refill Capacities Chart. | | |

| Component | Capacities | |
|-----------------------------------------------------------------------------------------------------------------------------------------------------------------------------------------------------------------------------------------------------------------------------------------------------------------------------------------------------------------------------------------------------------------------------------------------------------------------------------|--------------|--------|
| | U.S. Measure | Liters |
| Windshield Washer Reservoir | (Quarts) | |
| Standard Length | | |
| Front | 2.7 | 2.6 |
| Rear | 2.6 | 2.5 |
| Extended Length | | |
| Front | 2.7 | 2.6 |
| Rear | 3.9 | 3.7 |
| <p>① Service refill capacities are determined by filling the rear axle 1/4" to 9/16" (6.4 mm to 14.2 mm) below bottom of filler hole.</p> <p>NOTE: All rear axle lube quantities must be replaced every 100,000 miles (160,000 km) or if the axle has been submerged in water. Otherwise, the lube should not be checked or changed unless a leak is suspected or repair required. Refer to the maintenance schedule booklet.</p> <p>② Includes 1 qt. for filter replacement.</p> | | |

Lubricant Specifications

| Fluid | Ford Part Name or Equivalent | Ford Part Number | Ford Specification |
|------------------------------------------------------------------|--------------------------------------------------------------------------|-------------------|--------------------------------------------------------|
| Axle Fluid; Front (E-4wd) | Motorcraft MERCON® Automatic Transmission Fluid | XT-2-QDX | MERCON® |
| Axle Fluid; Conventional Traction-Lok Rear ¹ | Motorcraft SAE 80W90 Thermally Stable Rear Axle Lubricant | XY-80W90-QL | WSP- M2C197-A |
| Brake Fluid | High Performance DOT 3 Brake Fluid | C6AZ- 19542-AB | ESA- M6C25-A |
| Disc Brake Caliper Rail Compound | Silicone Dielectric Compound | D7AZ- 19A331-A | ESE- M1C75-B |
| Engine Coolant | Ford Premium Cooling System Fluid | E2FZ- 19549-AA | ESE M97B44-A |
| Engine Oil – Gasoline Engines | Motorcraft Motor Oil 5W30 Super Premium | X0-5W30-QSP | WSS-M2C- 153-F with API Certification Mark |
| Grease; Body, Hinges and Hood Latch | Multi Purpose Grease | D0AZ- 19584-AA | ESB- M1C93-B |

1. Add 4 oz. of EST-M2C118-A (Friction Modifier Part No. C8AZ-19B546-A) for complete refill of Ford Traction-Lok rear axles.

| Fluid | Ford Part Name or Equivalent | Ford Part Number | Ford Specification |
|-----------------------------------------------------------------------------------------------------------------------------------------------|-------------------------------------------|-------------------------|---------------------------|
| Grease: Accelerator Throttle Lever, Steering Column Joints, Parking Brake Linkage Pivots and Clevises and Transmission Control Linkage Pivots | Premium Long-Life Grease | XG-1-C | ESA-M1C75-B |
| Parking Brake Cable Lubricant | Speedometer Cable Lubricant | E6TZ-19581-A | ESF-M1C160-A |
| Power Steering Fluid, and Transfer Case Fluid | Motorcraft MERCON® ATF | XT-2-QXD | MERCON® |
| Steering Gear Lubricant | Steering Gear Grease | C3AZ-19578-A | ESW-M1C87-A |
| Transmission Fluid | Motorcraft MERCON® V ATF | XT-2-QM | MERCON® V |
| Windshield Washer Fluid | Ultra-Clear Windshield Washer Concentrate | C9AZ-19550-AC or BC | ESR-M17P5-A |

Engine Compartment

Your vehicle has one of the following types of engines:

- A 3.0 Liter SEFI, V-6 engine or
- A 4.0 Liter SEFI, V-6 engine.

The following pages show diagrams of each engine type and where to find items that you should regularly service.

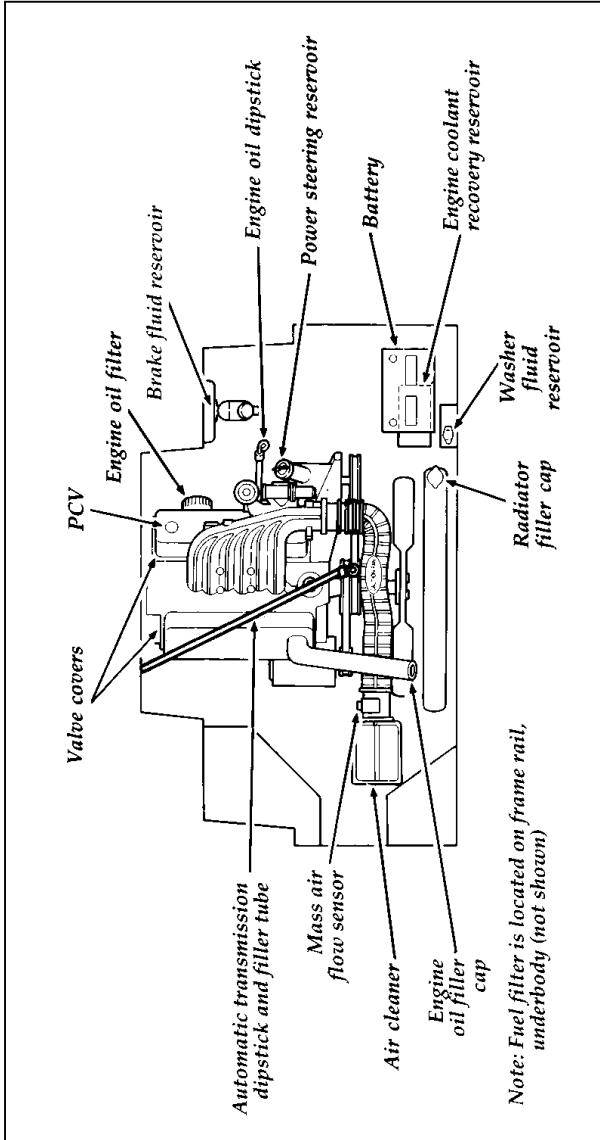

3.0L engine compartment service points

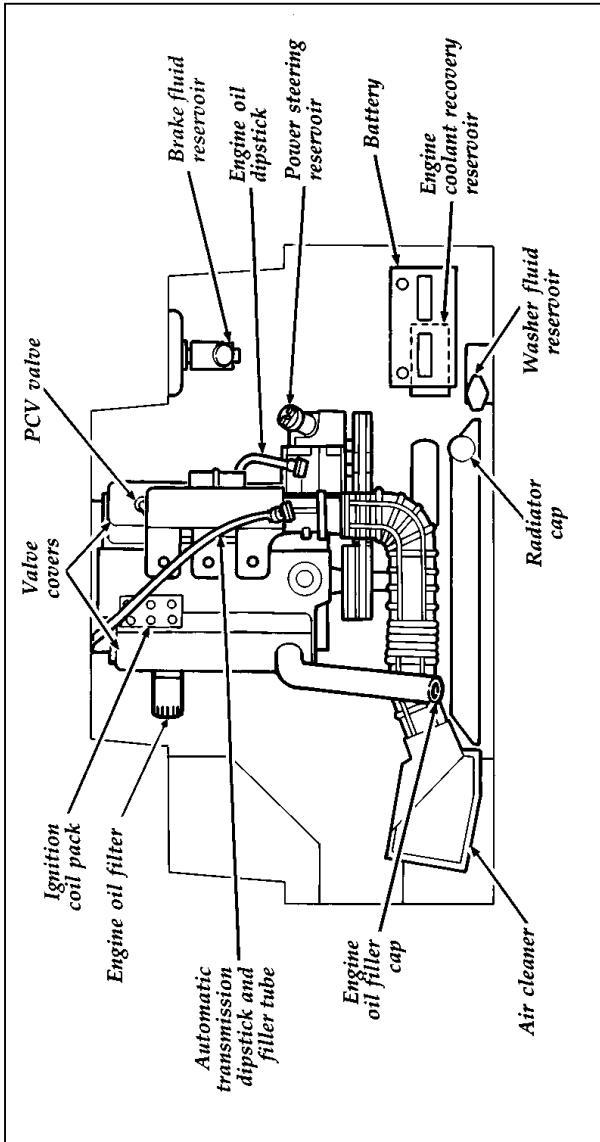

4.0L engine compartment service points

Your Vehicle Identification Number (VIN)

You should include your Vehicle Identification Number (VIN) any time you write to Ford Motor Company about your vehicle.

The Vehicle Identification Number is attached to your vehicle in the following places:

- on the metal tag attached to the top of the instrument panel on the driver's side — you can see the tag by looking through the windshield from outside your vehicle.

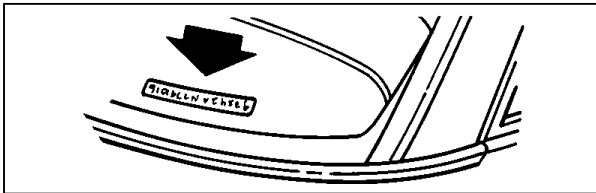

Vehicle Identification Number (VIN/Serial Number)

- on the Safety Compliance Certification Label —this label is attached to the left front door lock facing or the door latch post pillar. It is required by the National Highway Traffic Safety Administration and is made of special material. If someone tampers with it, it will be destroyed and/or a destruction pattern will appear.

The label contains the name of the manufacturer, the month and year of manufacture, the certification statement and the Vehicle Identification Number. The label also contains Gross Vehicle Weight Rating and Gross Axle Weight Ratings, wheel and tire data and information codes for additional vehicle data. For further information about the Safety Compliance Certification Label and the information contained on it, refer to the Index.

Reporting Safety Defects (U.S. Only)

Reporting Safety Defects (U.S. Only)

If you believe that your vehicle has a defect which could cause a crash or could cause injury or death, you should immediately inform the National Highway Traffic Safety Administration (NHTSA) in addition to notifying Ford Motor Company.

If NHTSA receives similar complaints, it may open an investigation, and if it finds that a safety defect exists in a group of vehicles, it may order a recall and remedy campaign. However, NHTSA cannot become involved in individual problems between you, your dealer, or Ford Motor Company.

To contact NHTSA, you may either call the Auto Safety Hotline toll-free at 1-800-424-9393 (or 366-0123 in the Washington, D.C. area) or write to: NHTSA, U.S. Department of Transportation, 400 Seventh Street, Washington D.C. 20590. You can also obtain other information about motor vehicle safety from the Hotline.

Customer Assistance

Roadside Assistance

Ford Motor Company has set up a 24-hour, seven-day-a-week hotline with trained operators who put you in touch with the help you need if you experience a problem with your vehicle. This complimentary service is provided to you throughout your warranty period of 3 years or 36,000 miles (60,000 km), whichever comes first. To purchase Roadside Assistance coverages beyond this period (available through Ford Auto Club in the United States or Ford and Lincoln-Mercury dealers in Canada), contact your Ford or Lincoln-Mercury dealer. Additional Roadside Assistance coverage is unavailable in Puerto Rico and the Virgin Islands.

Roadside Assistance will cover the following:

- Mount your spare if you have a flat tire.
- Jump-start your battery if it is dead.
- Unlock your vehicle if you are locked out.
- Bring you fuel if you run out.
- Tow your vehicle if you are stranded. Even non-warranty related tows, like accidents or getting stuck in mud or snow, are covered (some exclusions apply, such as impound towing and repossession).

How to use Roadside Assistance

Your Roadside Assistance identification card can be found in the Owner Guide portfolio in your glove compartment. Complete the card and place it in your wallet for quick reference.

To receive roadside assistance in the United States call 1-800-241-FORD (in Canada call 1-800-665-2006).

Should you need to arrange for roadside assistance yourself, Ford Motor Company will reimburse the reasonable cost. To obtain information about reimbursement call 1-800-241-FORD (in Canada call 1-800-665-2006).

If You Have a Service Problem

Ford Motor Company has authorized Ford and Lincoln-Mercury dealerships that can service your vehicle for you. This chapter tells you how to get service or maintenance for your vehicle.

Service/Maintenance Concerns (U.S. or Canada)

Ford recommends taking your vehicle to your selling dealer who wants to ensure your continued satisfaction. You may, however, take your vehicle to any authorized Ford or Lincoln-Mercury dealer. In most cases, your dealer will be able to resolve your concern.

If you are not satisfied with the service you received from your dealership's service department, talk to the service manager at the dealership, or if you still are not satisfied, talk to the owner or general manager of the dealership. In most cases, you will have your concern resolved at this level.

If you are away from home when your vehicle needs to be serviced, or if you need more help than the dealer gave you, contact the Ford Customer Assistance Center to find an authorized dealership that may be able to help.

*Ford Motor Company
Customer Assistance Center
300 Renaissance Center
P.O. Box 43360
Detroit, Michigan 48243
1-800-392-3673 (FORD)
TDD for the hearing impaired: 1-800-232-5952*

If you live in Canada and have any questions or concerns that the dealership cannot answer, contact the Customer Assistance Centre.

*Customer Assistance Centre
Ford Motor Company of Canada, Limited
P.O. Box 2000
Oakville, Ontario L6J 5E4
1-800-565-3673 (FORD)*

To process your request, the Ford Customer Assistance Center needs the following information:

- your telephone number (both business and home)
- the name of the dealer and the city where the dealership is located
- the year and make of your vehicle
- the date purchased
- the current mileage on your vehicle
- your Vehicle Identification Number (VIN)

If you still have a complaint involving a warranty dispute, you may wish to contact the Dispute Settlement Board (U.S. only) or the Canadian Motor Vehicle Arbitration Plan (CAMVAP) in Canada.

A warranty dispute must be submitted to the Dispute Settlement Board before taking action under the Magnuson-Moss Warranty Act, or to the extent allowed by state law, before pursuing replacement or repurchase remedies provided by certain state laws. This dispute handling procedure is not required prior to enforcing state created rights or other rights which are independent of the Magnuson-Moss Warranty Act or state replacement or repurchase laws.

The Dispute Settlement Board (U.S. Only)

The Dispute Settlement Board is:

- an independent, third-party arbitration program for warranty disputes
- available free to owners and lessees of qualifying Ford Motor Company vehicles

The Dispute Settlement Board may not be available in all states. Ford Motor Company reserves the right to change eligibility limitations, modify procedures and/or to discontinue this service without notice and without incurring obligations.

What Kinds of Cases Does the Board Review?

The Board reviews all warranty performance complaints on Ford, Mercury and Lincoln cars and Ford and Mercury light trucks under the new vehicle limited warranty that have not been resolved by either a dealer or Ford Motor Company, except those involving:

- a non-Ford product
- a non-Ford dealership
- a vehicle sales transaction
- request for reimbursement of consequential expenses. Expenses incidental to the warranty complaint being reviewed are eligible for consideration.
- items not covered by the new vehicle limited warranty
- items covered by a service contract
- alleged liability claims
- property damage where the damage is significant when compared to the economic loss alleged under the warranty dispute
- cases currently in litigation
- vehicles not used primarily for family, personal, or household purposes (except in states where the Dispute Settlement Board is required to review commercial vehicles)

Complaints involving vehicles in which applicable new vehicle limited warranties have expired at receipt of your application are not eligible. Eligibility may differ according to state law. For example, see the unique brochures for California and Wisconsin purchasers/lessees.

How Does the Board Work?

The Board consists of:

- three consumer representatives
- a Ford or Lincoln/Mercury dealer

Consumer candidates for Board membership are recruited and trained by an independent consulting firm. Dealers are chosen because of their business leadership qualities.

What the Board needs

To have your case reviewed you must complete the application in the DSB brochure and mail it to the address provided on the application form.

Your application is reviewed and, if it is determined to be eligible, you will receive an acknowledgment indicating:

- the file number assigned to your application
- the toll-free phone number of the DSB's independent administrator

Your dealership and a Ford Motor Company representative are asked to submit statements at this time.

To review your case properly, the Board needs the following information:

- legible copies of all documents and maintenance or repair orders relevant to the case
- the year, make, model, and Vehicle Identification Number (VIN) listed on your vehicle ownership license
- the date of repair(s) and mileage at the time of occurrence(s)
- the current mileage
- the name of the dealer who sold or serviced the vehicle
- a brief description of your unresolved concern
- a brief summary of the action taken with the dealer and Ford Motor Company
- the names (if known) of all the people you contacted at the dealership

- a description of the action you expect to resolve your concern

Should your case NOT qualify for review, a letter of explanation will be mailed to you.

Oral presentations

If the involved vehicle is within 36 months and 36,000 miles of the warranty start date, you have the right to make an oral presentation before the Board. Indicate your choice to do so on the application. Oral presentations may also be requested by the Board.

Making a decision

Board members will review all available information related to the complaint, including oral presentations, if necessary. They then arrive at a fair and impartial decision, decided by a simple majority vote.

Because the Board usually meets only once a month, some cases may take longer than 30 days to be reviewed. The Board makes every effort to resolve each case within 40 days of receiving the consumer application form.

After your case is reviewed, the Board mails you a decision letter. The Board also provides a form on which to accept or reject the Board's decision. The decisions of the Board are binding on the dealer and Ford, but not on consumers who may elect to pursue other remedies available to them under state or federal law. Decisions of the Board may be presented as evidence by any party in subsequent legal proceedings that may be initiated, where allowed by law.

To Request a DSB Brochure/Application

For a brochure/application, speak to your dealer or write to the Board at the following address:

*Dispute Settlement Board
P.O. Box 5120
Southfield, MI 48086-5120*

Ford of Canada does not have a Dispute Settlement Board. If you have a problem that cannot be resolved by an agreement among you, Ford of Canada, and the Ford dealer, contact the Canadian Motor Vehicle Arbitration Plan (CAMVAP). In many areas of Canada, CAMVAP will help resolve the problem and, if necessary, will arrange for the matter to be arbitrated.

Ford of Canada Customer Assistance

If you live in Canada and have any questions or concerns that the dealership cannot answer, contact the Customer Assistance Centre.

*Customer Assistance Centre
Ford Motor Company of Canada, Limited
P.O. Box 2000
Oakville, Ontario L6J 5E4
1-800-565-3673 (FORD)*

Mediation/Arbitration Program (Canada Only)

In those cases where you continue to feel that the efforts by Ford and the dealer to resolve a factory-related vehicle service concern have been unsatisfactory, Ford of Canada participates in an impartial third party mediation/arbitration program administered by the Canadian Motor Vehicle Arbitration Plan (CAMVAP).

The CAMVAP program is a straight-forward and relatively speedy alternative to resolve a disagreement when all other efforts to produce a settlement have failed. This procedure is without cost to you and is designed to eliminate the need for lengthy and expensive legal proceedings.

In the CAMVAP program, impartial third-party Arbitrators conduct hearings at mutually convenient times and places in an informal environment. These impartial Arbitrators review the positions of the parties, make decisions and, where appropriate, render awards to resolve disputes. CAMVAP decisions are fast, fair and final as the arbitrator's award is binding on both you and Ford of Canada.

CAMVAP services are available in all territories and provinces, except Quebec. For more information, without charge or obligation, call your CAMVAP Provincial Administrator directly at 1-800-207-0685.

Getting Help Outside the U.S. and Canada

Before you export your vehicle to a foreign country, contact the appropriate foreign embassy or consulate to make sure local regulations do not prevent you from registering your vehicle. Officials at the embassy can also help you decide whether you should import your vehicle to that country.

Officials at the embassy or consulate can tell you where to get unleaded fuel. If you cannot get unleaded fuel or can get only fuel with an anti-knock index that is lower than your vehicle needs, contact a district or owner relations office before you leave the U.S. or Canada.

Use of leaded fuel in your vehicle without a proper conversion may damage the effectiveness of your emissions control system and may cause engine knocking or serious engine damage. Ford Motor Company is not responsible for any damage that is caused by use of improper fuel.

You may also have difficulty importing your vehicle back into the U.S. if you use leaded fuel.

If your vehicle must be serviced while you are traveling or living in Central or South America, the Caribbean, or the Middle East, contact the nearest Ford dealership. If the dealership cannot help you, write to:

FORD MOTOR COMPANY
WORLDWIDE EXPORT OPERATIONS
1555 Fairlane Drive
Fairlane Business Park #3
Allen Park, Michigan 48101 U.S.A.
Telephone: (313) 594-4857
Fax: (313) 390-0804

If you are in other foreign countries, contact the nearest Ford dealership. If the dealership cannot help you, they can direct you to the appropriate Ford affiliate office.

If you buy your vehicle in North America and then relocate outside of the U.S. or Canada, register your Vehicle Identification Number and new address with Ford Motor Company Export Operations.

Accessories

Ford Accessories for Your Vehicle

Ford has many fine products available from your dealer to clean your vehicle and protect its finishes. For best results, use the following, or products of equivalent quality:

- Ford Custom Clear Coat Polish
- Ford Custom Silicone Gloss Polish
- Ford Custom Vinyl Protectant
- Ford Deluxe Leather and Vinyl Cleaner
- Ford Extra Strength Spot and Stain Remover
- Ford Extra Strength Tar and Road Oil Remover
- Ford Extra Strength Upholstery Cleaner
- Ford Extra Strength Whitewall Tire Cleaner
- Ford Multi-Purpose Cleaner
- Ford Premium Car Wash Concentrate
- Ford Triple Clean
- Ford Ultra-Clear Spray Glass Cleaner

A wide selection of accessories is available through your local authorized dealer. These fine accessories have been engineered specifically to fulfill your automotive needs. They are custom designed to complement the style and aerodynamic appearance of your Ford-built vehicle. In addition, each accessory is made from high quality materials and meets or exceeds Ford's rigid engineering and safety specifications. That is why Ford brand accessories are warranted for up to 3 years or 36,000 miles (60,000 km), whichever comes first. See your dealer for complete warranty information and accessory availability.

Comfort and Convenience

Console/Storage and Beverage
Engine Block Heater

Protection and Appearance Equipment

Cargo Liner (Soft)
Cleaners
Floor Mats
Hood Deflector
Lubricants
Running Boards
Soft Luggage Cover
Super Seal Fabric Protector (U.S. only)
Super Seal Undercoating (U.S. only)
Touch-Up Paints
Waxes
Wheel Splash Guards
Side Window Deflectors
Door Edge Guards
Front End Cover

Safety Equipment

Anti-Theft Lug Nuts (Alum. Wheels only)
Vehicle Security System
Remote Keyless Entry

Travel Equipment

- Bike Adaptor for Clamp-on Rack
 - Water Sports Adaptor for Clamp-on Rack (canoe, kayak, surfboard)
- Cargo Retention Net
- Fog Lights
- Four Seasons Base Rack (Permanent Mount)
 - Bike Rack Adaptor (Permanent Mount)
 - Ski Rack Adaptor
- Speed Control
- Sportsrack – Roof Rack (Clamp-on)

NOTE: When adding accessories, equipment, passengers, and luggage to your vehicle, do not exceed the total weight capacity of the vehicle or of the front or rear axle (GVWR, GAWR as shown on the Safety Compliance Certification Label). Consult your dealer for specific weight information.

NOTE: The Federal Communications Commission (FCC) or the Canadian Radio Telecommunications Commission (CRTC) regulates the use of mobile communications systems — such as two-way radios, telephones, and theft alarms — that are equipped with radio transmitters. Any such equipment installed in your vehicle should comply with FCC or CRTC regulations and should be installed only by a qualified technician.

NOTE: Mobile communications systems may harm the operation of your vehicle, particularly if they are not properly designed for automotive use or are not properly installed. For example, when operated, such systems may cause the engine to stumble or stall. In addition, such systems may themselves be damaged or their operation affected by operating your vehicle. (Citizens band [CB] transceivers, garage door openers, and other transmitters whose power output is 5 watts or less will not ordinarily affect your vehicle's operation.)

NOTE: Because we have no control over the installation, design, or manufacture of such systems, Ford cannot assume responsibility for any adverse effects or damage that may result if you use this equipment.

1996 Aerostar Owner Manual Order Form

| PUBLICATION FORM NO. | DESCRIPTION |
|-------------------------|-----------------------------------------------------------------------------|
| FCS-12199-96 | 1996 Aerostar Service Manual |
| FCS-12106-96 | 1996 Powertrain Control/ Emission Diagnosis |
| FCS-12137-96 | 1996 Light Truck Service Specifications |
| 93-VID-OM | Ford and the American Dream (50) Minutes of Historic/Nostalgic Videotape |
| | |

- **NOTE:** For publications prior to year shown above, write for availability to the address shown below.
- Please allow ample time for postal service delivery.

U.S. RESIDENTS

Make checks payable to: HELM, INCORPORATED

MAIL ORDER TO:

HELM, INCORPORATED
P.O. Box 07150
Detroit, Michigan 48207

OR ORDER TOLL FREE:

1-800-782-4356

Monday - Friday 8:00 A.M. - 6:00 P.M. EST

For Credit Card Holder Orders Only

CANADIAN RESIDENTS

Make cheques payable to: Ford Motor Company of Canada, Ltd.

MAIL ORDER TO:

Ford Motor Company of Canada, Ltd.
Service Publications
P.O. Box 1580, Station B
Mississauga, Ontario, Canada L4Y 4G3

OR ORDER TOLL FREE:

1-800-387-4966

Monday - Friday 8:30 A.M. - 6:00 P.M. EST

For Credit Card Holder Orders Only

U.S. RESIDENTS USE THIS PAGE

| | |
|---------------------------------------------------------------------------------------------------------------------------------------------------------------------------------------------------------------------------------------------------------------------------------------|-------------------------------------------------------------------------------------------------|
| ORDER TOLL FREE 1-800-782-4356 | NOTE: For Credit Card Holder Orders Only Monday-Friday 8:00 A.M.-6:00 P.M. EST |
| <i>If further information is needed, write to the address shown below or call 1-800-782-4356. Material cannot be returned for credit without receiving advance authorization within 14 days of delivery. On returns, a re-stocking fee may be applied against the original order.</i> | |

| 1 9 9 6 | PUBLICATION FORM NUMBER | 1996 AEROSTAR PUBLICATION | QTY. | PRICE EACH | TOTAL PRICE |
|------------------|----------------------------|------------------------------|-------------|---------------|----------------|
| | | FCS-12199-96 | Aerostar SM | | \$ 97.00 |
| | FCS-12106-96 | Powertrain Control/ED | | 160.00 | |
| | FCS-12137-96 | Light Truck Service Spec. | | 32.00 | |
| | 93-VID-OM | Videotape | | 19.95 | |
| | | | | | |

| | | | | | |
|----------------------------------------------|--------------------------------------------------------------------------------------------------------------------------------------------------------------------------------------------------------------------------------------------------------------------------------------------------------------------------------------------------------------------------------------------------------------------------------------------------------------------------|--|--|-----------------------------------------|--------|
| P A Y M E N T | <input type="checkbox"/> Check or Money Order payable to Helm, Inc. (USA funds only - do not send cash.) | | | TOTAL MATERIAL | |
| | <input type="checkbox"/> MasterCard | | | Michigan Purchasers add 6% sales tax | |
| | <input type="checkbox"/> VISA <input type="checkbox"/> Discover | | | Handling Charge | \$4.00 |
| | Account Number: <input type="text"/> <input type="text"/> <input type="text"/> <input type="text"/> <input type="text"/> <input type="text"/> <input type="text"/> <input type="text"/> <input type="text"/> <input type="text"/> <input type="text"/> <input type="text"/> <input type="text"/> <input type="text"/> <input type="text"/> <input type="text"/> <input type="text"/> <input type="text"/> <input type="text"/> <input type="text"/> <input type="text"/> | | | GRAND TOTAL | |
| | Expiration Date mo/yr: <input type="text"/> <input type="text"/> / <input type="text"/> <input type="text"/> <input type="checkbox"/> Check here if billing address is different from shipping address shown. | | | | |
| (CUSTOMER SIGNATURE) | | | | (DATE) | |

| | | |
|----------------------------------------|-------------------------------------------------------------------------------------------------------------------------------------------------------------------------------------------------------------------------------------------------------------------------------------------------------------------------------------------------------------------------------------------------------------------------------------------------|--|
| S H I P T O | NOTE: Dealers and Companies please provide dealer or company name, along with the name of the person to whom the shipment should be sent. For purchases outside U.S.A. and Canada, please write to the following address for quotation. Mail completed order form to: HELM, INC • P.O. Box 07150 • Detroit, MI 48207. Please allow 6-8 weeks for delivery. Prices are subject to change without notice and without incurring obligation. | |
| | (CUSTOMER NAME) (ATTENTION) | |
| | (STREET ADDRESS - NO P.O. BOX NUMBERS) (APT.NO.) | |
| | (CITY) (STATE) (ZIP CODE) | |
| | DAYTIME TELEPHONE AREA CODE () _____ | |

CANADIAN RESIDENTS USE THIS PAGE

| | |
|----------------------------------------------------------------------------------------------------------------------------------------------------------------------------------------------------------------------------------------------------------------------------------------------|--------------------------------------------------------------------------------------------------------------------------------------------|
| <p>ORDER TOLL FREE 1-800-387-4966</p> | <p>NOTE: For Credit Card Holder Orders Only Monday-Friday 8:30 A.M.-6:00 P.M. EST</p> |
| <p><i>If further information is needed, write to the address shown below or call 1-800-387-4966. Material cannot be returned for credit without receiving advance authorization within 14 days of delivery. On returns, a re-stocking fee may be applied against the original order.</i></p> | |

| 1 9 9 6 | PUBLICATION FORM NUMBER | 1996 AEROSTAR PUBLICATION | QTY. | PRICE EACH | TOTAL PRICE |
|------------------|----------------------------|------------------------------|----------------|---------------|----------------|
| | | FCS-12199-96 | Service Manual | | \$102.00 |
| | FCS-12106-96 | Powertrain Control/ED | | 160.00 | |
| | FCS-12137-96 | Light Truck Service Spec. | | 39.00 | |
| | | | | | |

| | | | | | | | | | | | |
|----------------------------------------------|---------------------------------------------------------------------------------------------------------------------------------------------------------------------------------------------------------------------------------------------------------------------------------------------------------------------------------------------------------------------------------------------------------------------------------------------------------------------------------------------------------------------------------------------------------------------------------|--------|---------------------------------------------------------------------------------------------------------------------------------------------------------------------------------------------------------------------------------------------------------------------------------------------------------------------------------------------------------------------------------------------------------------------------------------------------------------------------------------------------------------------------------------------|-----------------------|--|---------------|--|------------------------------------------------------------------------------------------------------------------------------------------------------------------|--|--------------------|--|
| P A Y M E N T | <input type="checkbox"/> Cheques or Money Order payable to Ford Motor Company of Canada, Ltd. (Do not send cash.) | | <table border="1" style="width: 100%; border-collapse: collapse;"> <tr><td colspan="2" style="text-align: center;">TOTAL MATERIAL</td></tr> <tr><td colspan="2" style="text-align: center;">G. S. T. (7%)</td></tr> <tr><td colspan="2" style="text-align: center;">Handling/Shipping Charge Individual Item Order Except Service Manuals \$5.00 OR Service Manuals and Multiple Item Orders \$10.00 (French Owner Guide: No Charge)</td></tr> <tr><td colspan="2" style="text-align: center;">GRAND TOTAL</td></tr> </table> | TOTAL MATERIAL | | G. S. T. (7%) | | Handling/Shipping Charge Individual Item Order Except Service Manuals \$5.00 OR Service Manuals and Multiple Item Orders \$10.00 (French Owner Guide: No Charge) | | GRAND TOTAL | |
| | TOTAL MATERIAL | | | | | | | | | | |
| | G. S. T. (7%) | | | | | | | | | | |
| | Handling/Shipping Charge Individual Item Order Except Service Manuals \$5.00 OR Service Manuals and Multiple Item Orders \$10.00 (French Owner Guide: No Charge) | | | | | | | | | | |
| | GRAND TOTAL | | | | | | | | | | |
| <input type="checkbox"/> VISA Only | | | | | | | | | | | |
| Account Number | <input style="width: 20px; height: 15px;" type="text"/> <input style="width: 20px; height: 15px;" type="text"/> <input style="width: 20px; height: 15px;" type="text"/> <input style="width: 20px; height: 15px;" type="text"/> <input style="width: 20px; height: 15px;" type="text"/> <input style="width: 20px; height: 15px;" type="text"/> <input style="width: 20px; height: 15px;" type="text"/> <input style="width: 20px; height: 15px;" type="text"/> <input style="width: 20px; height: 15px;" type="text"/> <input style="width: 20px; height: 15px;" type="text"/> | | | | | | | | | | |
| Expiration Date mo/yr: | <input style="width: 20px; height: 15px;" type="text"/> <input style="width: 20px; height: 15px;" type="text"/> <input style="width: 20px; height: 15px;" type="text"/> <input style="width: 20px; height: 15px;" type="text"/> <input style="width: 20px; height: 15px;" type="checkbox"/> Check here if billing address is different from shipping address shown. | | | | | | | | | | |
| (CUSTOMER SIGNATURE) | | (DATE) | | | | | | | | | |

| | | |
|----------------------------------------|-------------------------------------------------------------------------------------------------------------------------------------------------------------------------------------------------------------------------------------------------------------------------------------------------------------------------------------------------------------------------------------------------------------------------------------|--------------------------|
| S H I P T O | <p>NOTE: Dealers and Companies please provide dealer or company name, along with the name of the person to whom the shipment should be sent. Mail completed order form to: Ford Motor Company of Canada, Ltd. • Service Publications • P.O. Box 1580, Station B Mississauga, Ontario, Canada L4Y 4G3. Please allow 6-8 weeks for delivery. Prices are subject to change without notice and without incurring obligation.</p> | |
| | (CUSTOMER NAME) | (ATTENTION) |
| | (STREET ADDRESS - NO P.O. BOX NUMBERS) | (APT.NO.) |
| | (CITY) | (PROVINCE) (POSTAL CODE) |
| | DAYTIME TELEPHONE | AREA CODE () _____ |

| No. | Description | Refer to this label for information regarding: |
|-----|-------------------------------------------|--------------------------------------------------------------------------|
| 1 | Air Bag Warning Label | Air bag precautions |
| 2 | Child Seat Label | Child seat installation precautions |
| 3 | Fuel Pump Shut-Off Label | Fuel pump shut off location |
| 4 | Safety Compliance Certification Label | Name and date of manufacturer, GVWR*, GAWR**, wheel and tire information |
| 5 | Vehicle Identification Number (VIN) Label | Servicing or warranty information specific to your vehicle |

* Gross Vehicle Weight Rating
 ** Gross Axle Weight Rating

Q U I C K I N D E X

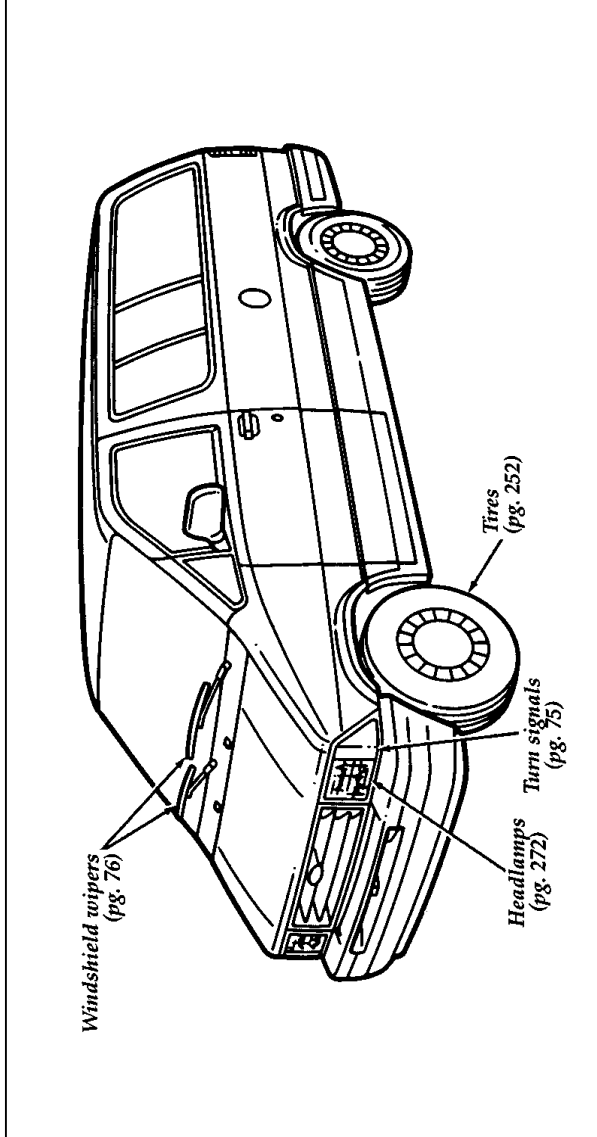

Front exterior view

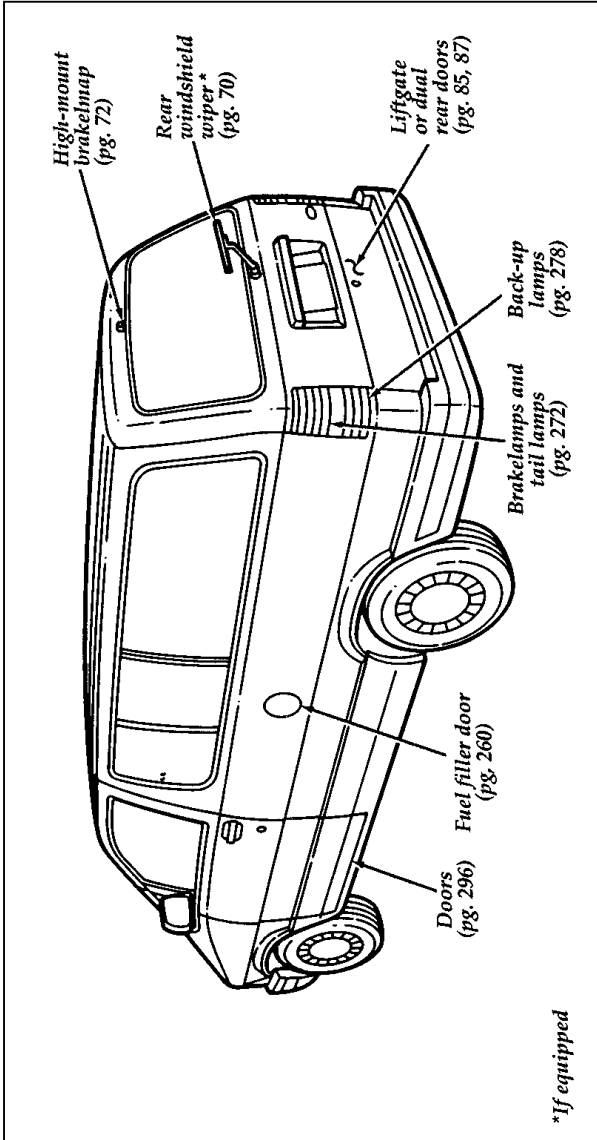

Rear exterior view

Q
U
I
C
K
I
N
D
E
X

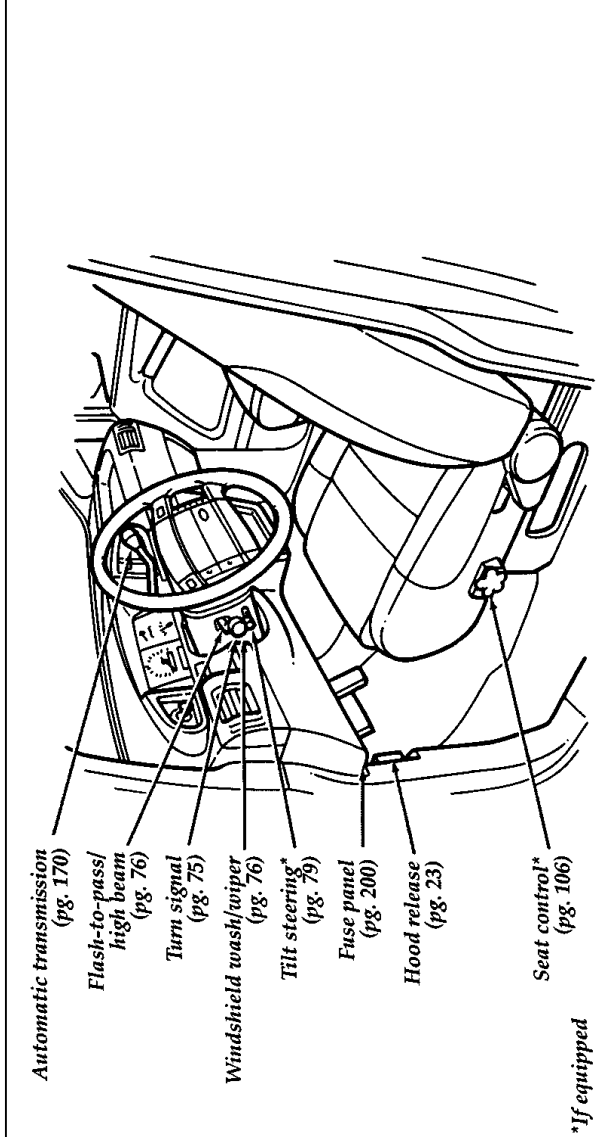

Entrance view

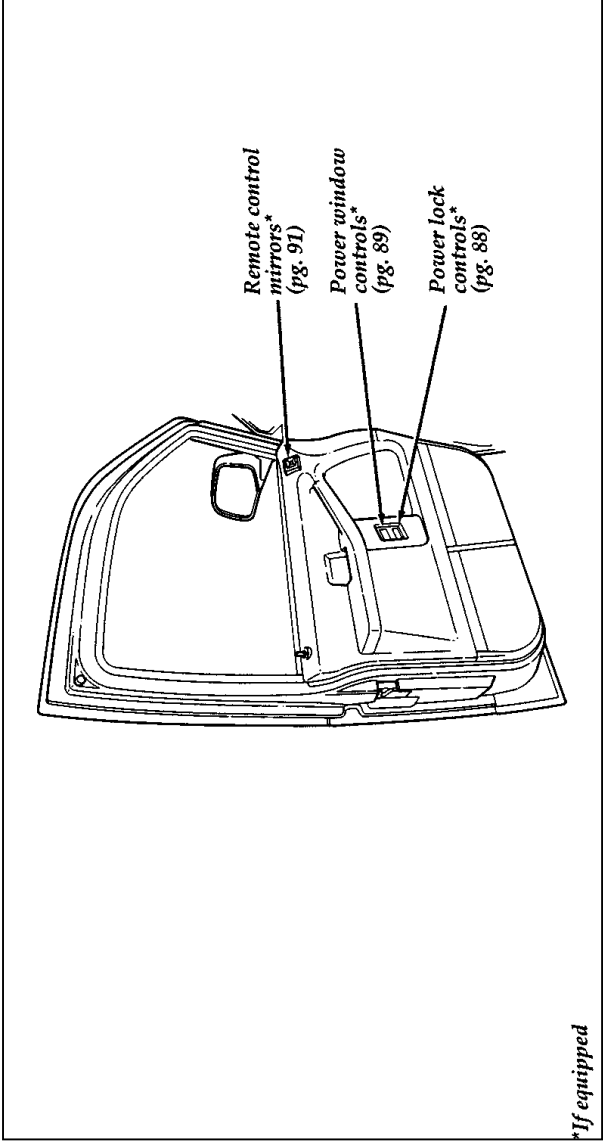

**Q
U
I
C
K
I
N
D
E
X**

**If equipped*

Driver's door

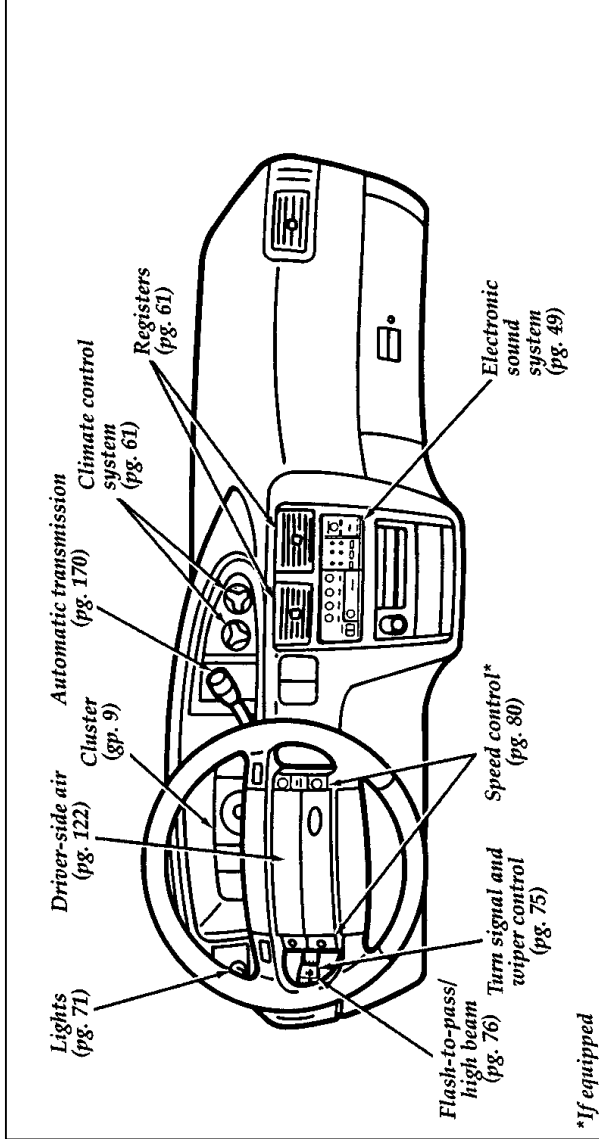

Instrument panel

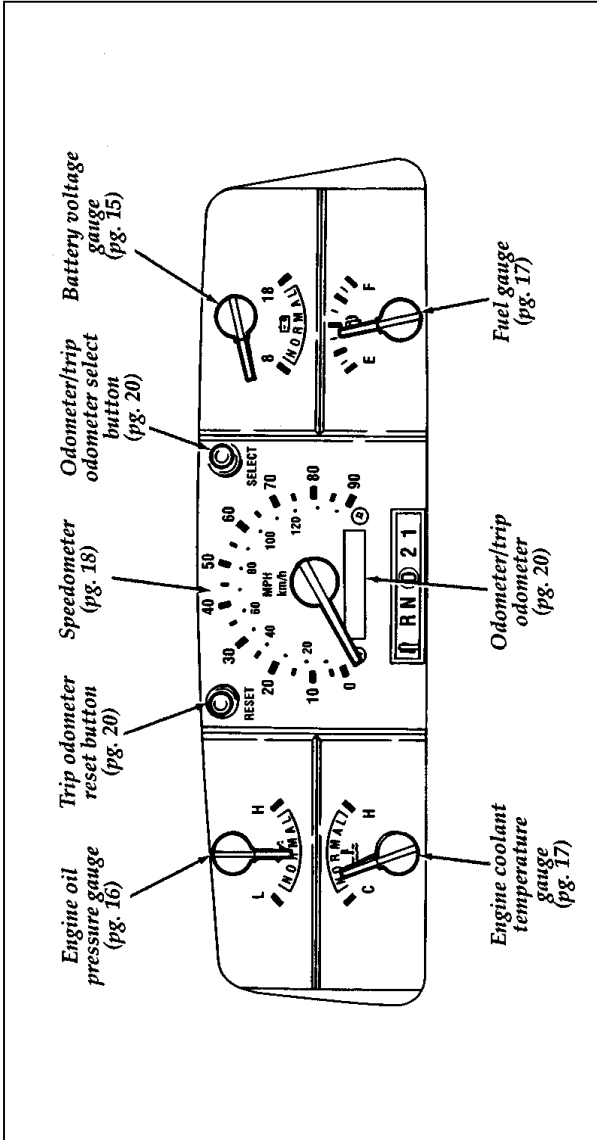

Instrument cluster

**Q
U
I
C
K
I
N
D
E
X**

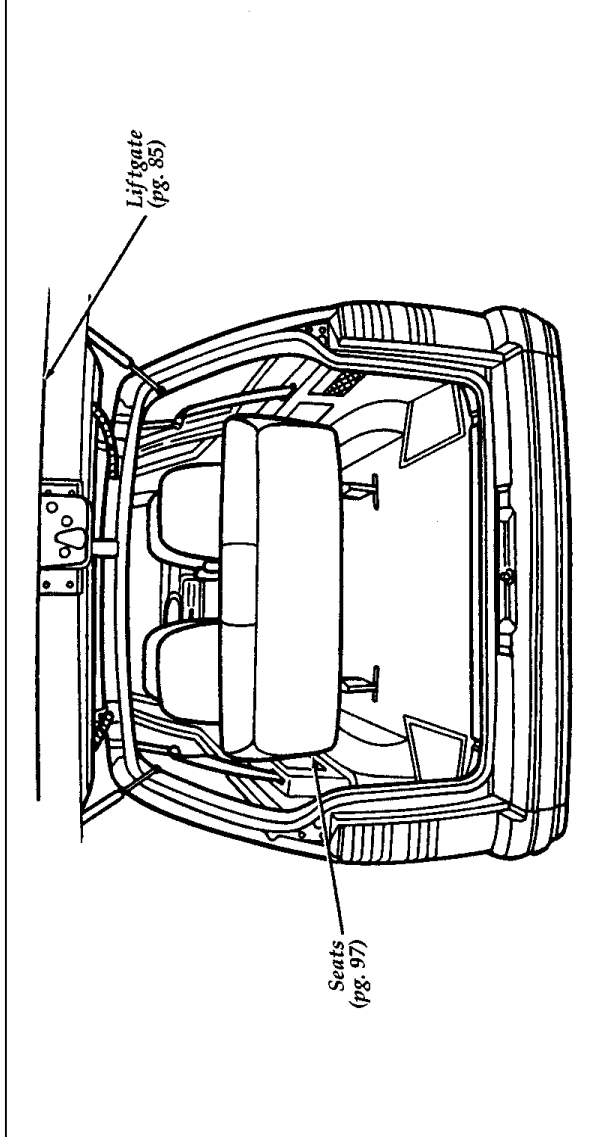

Rear cargo area (extended length wagon shown)

Index

A

| | |
|--------------------------------------------------|----------|
| Accessory position on the ignition | 74 |
| Additives, engine oil | 233 |
| Air bag supplemental restraint system | |
| and child safety seats | 130 |
| description | 122, 125 |
| driver air bag | 122, 125 |
| indicator light | 13 |
| operation | 125 |
| passenger air bag | 125 |
| service and information labels | 125 |
| tone generator | 127 |
| Air cleaner filter | |
| location | 297 |
| specifications | 293 |
| Air conditioning | |
| auxiliary heater and air conditioner | 67 |
| manual heating and air conditioning | |
| system | 62 |
| Alcohol, in fuel | 265 |
| Antenna, radio | |
| (see Electronic sound system) | 21 |
| Antifreeze (see Engine coolant) | 240 |
| Anti-lock brake system (ABS) | |
| description | 163 |
| see also Brake | 163 |
| warning light | 9 |
| Appeals (see Dispute settlement board) | 306 |
| Assistance (see Customer assistance) | 303 |
| Audio system (see Electronic | |
| sound system) | 21 |

| | |
|-------------------------------------------|----------|
| Autolamp system (see Headlamps) | 72 |
| Automatic transmission | |
| fluid, adding | 248 |
| fluid, checking | 247 |
| fluid, refill capacities | 294 |
| fluid, specification. | 296 |
| Axle | |
| lubricant specifications. | 296 |
| refill capacities | 294 |
| traction lok. | 177, 254 |

B

| | |
|-------------------------------------------|----------|
| Basic vehicle warranty | 3 |
| Battery | |
| acid, treating emergencies | 223, 250 |
| charging system warning light | 13 |
| disconnecting | 226 |
| how to service | 249 |
| jumping a disabled battery. | 222 |
| maintenance-free | 249 |
| proper disposal, recycling | 250 |
| replacement, specifications | 293 |
| servicing | 249 |
| voltage gauge. | 13, 15 |
| when storing your vehicle | 285 |
| Brake fluid | |
| brake warning light | 9 |
| checking and adding | 236 |
| description | 236 |
| specifications | 237, 296 |
| Brakelamp, high-mount brakelamp | 72 |
| Brakes | |
| adjustment | 163 |
| anti-lock | 163 |
| applying the brakes | 166 |
| brake warning light | 9 |
| fluid, checking and adding. | 236 |
| fluid, refill capacities | 236, 294 |

| | |
|--------------------------------------|----------|
| Brakes (continued) | |
| fluid, specifications | 237, 296 |
| front disc | 163 |
| if brakes do not grip well | 164, 166 |
| master cylinder | 236 |
| new brake linings. | 5 |
| noise | 163, 165 |
| parking | 166 |
| power braking | 163 |
| rear anti-lock. | 164 |
| servicing | 164, 236 |
| stopping distances | 165 |
| trailer | 195 |
| when storing your vehicle. | 285 |
| Brake-shift interlock | 155, 171 |
| Break-in period | 5 |
| Brights (high beams) | 14 |
| Built-in child seat | |
| cleaning | 283 |
| operation | 141 |
| Bulbs, replacing | |
| halogen | 272 |
| headlamps | 272 |

C

| | |
|-----------------------------------------------------------------|--------|
| Canada, customer assistance | 310 |
| Canada, warranty information | 3 |
| Canadian Motor Vehicle Arbitration Plan (CAMVAP). | 311 |
| Capacities for refilling fluids | 294 |
| Carbon monoxide in exhaust. | 160 |
| Car seats for children (see Child safety seats) | 130 |
| Cassette tape player (see Electronic sound system) | 35, 49 |
| Catalytic converter | 269 |
| CD player (see Electronic sound system) . . . | 29 |
| Chains, tires | 259 |
| Changing a tire | 209 |

| | |
|----------------------------------------------|----------|
| Charging system gauge | 15 |
| Charging system warning light | 13 |
| Child safety restraints | |
| built-in child seat | 141 |
| child safety belts | 150 |
| child safety seats | 130 |
| Child safety seats | |
| and air bags | 130 |
| attaching with tether straps | 139 |
| automatic locking mode (retractor) | 112, 130 |
| built-in child seat | 141 |
| in front seat | 130 |
| in rear outboard seat | 130 |
| in rear seat | 130 |
| tether anchorage hardware | 139 |
| Chime | |
| headlamps on. | 14 |
| key in ignition | 14 |
| safety belt | 11 |
| Circuit breakers | |
| checking and replacing | 209 |
| see also fuses | 200 |
| Cleaning your vehicle | |
| built-in child seat | 283 |
| CD player and discs. | 32 |
| chrome and aluminum parts | 280 |
| engine compartment. | 281 |
| exterior | 280 |
| exterior lamps | 281 |
| fabric | 282 |
| headlamps | 281 |
| instrument panel | 61, 281 |
| instrument panel lens | 282 |
| interior. | 282 |
| interior lamps. | 282 |
| mirrors. | 91 |

| | |
|--------------------------------------------------------|----------|
| Cleaning your vehicle (continued) | |
| plastic parts | 281 |
| polishing. | 280 |
| rear windows | 70 |
| rustproofing | 280 |
| safety belts. | 283 |
| tail lamps | 281 |
| upholstery and interior trim | 282 |
| washing | 280 |
| waxing | 280 |
| wheels. | 281 |
| windows. | 70 |
| Climate control system | |
| air conditioning | 62 |
| heating | 62 |
| heating only system. | 65 |
| Clock | 28, 44 |
| Cold engine starting. | 154 |
| Combination lap and shoulder belts | 108, 110 |
| Compact disc player | |
| (see Electronic sound system) | 22, 29 |
| Compact disc radio | |
| (see Electronic sound system) | 22 |
| Console, description. | 92 |
| Controls, mirrors | 91 |
| Convenience kit in cargo area | 211 |
| Coolant (see Engine coolant) | |
| checking and adding | 240 |
| drain and flush. | 243 |
| preparing for storage | 285 |
| refill capacities | 294 |
| specifications | 296 |
| temperature gauge | 17 |
| warnings. | 240 |
| Cooling fan. | 230 |
| Crankcase emission filter. | 293 |
| Customer Assistance Center, Ford (U.S.). | 305 |
| Customer Assistance Centre, Ford of Canada. | 305, 310 |

D

| | |
|---------------------------------------------------|----------|
| Daytime running light system | 72 |
| Defects, reporting | 301 |
| Defrost, rear window | 69 |
| Dipstick | |
| automatic transmission fluid | 246, 248 |
| engine oil | 234 |
| power steering fluid. | 244 |
| Disabled vehicle (see Towing) | 226 |
| Dispute Settlement Board | 306 |
| Doors | |
| door ajar warning light | 11 |
| lubricant specifications. | 296 |
| Driveline universal joint and slip yoke | 248 |
| Driving under special conditions, | |
| heavy load | 179 |

E

| | |
|-----------------------------------------------------------------------------|------------|
| Electrical system | |
| circuit breakers | 209 |
| fuses. | 200 |
| operating when the engine is off | 74 |
| Electronic radio with cassette (see Electronic sound system) | 49 |
| Electronic sound system | |
| accessory delay | 74 |
| tuning the radio | 23, 37, 49 |
| warranty and service information. | 58 |
| Electronic stereo cassette radio (see Electronic sound system) | 49 |
| Electronic stereo radio (see Electronic sound system) | 49 |
| Emergencies, roadside | |
| assistance. | 303 |
| battery acid spills | 223, 251 |
| fuel | 265 |
| jump-starting | 222 |
| towing | 226 |

| | |
|------------------------------------------|----------|
| Emergency brake (parking brake). | 165 |
| Emission control system | |
| catalytic converter | 269 |
| emissions warranty | 3, 269 |
| Engine | |
| check engine warning light | 12 |
| does not start | 158 |
| fuel injected engine, starting. | 153 |
| fuel pump shut-off switch. | 158 |
| preparing to start. | 153 |
| refill capacities | 294 |
| service points | 297 |
| starting | 154 |
| starting after a collision | 158 |
| storing your vehicle. | 283 |
| Engine block heater | 157 |
| Engine coolant | |
| checking and adding | 240 |
| checking hoses | 243 |
| disposal | 230, 248 |
| drain and flush. | 243 |
| preparing for storage | 285 |
| proper solution. | 230, 248 |
| recovery reservoir | 240, 297 |
| refill capacities | 294 |
| specifications | 296 |
| temperature gauge | 17 |
| Engine coolant temperature gauge | |
| description | 17 |
| mechanical | 17 |
| Engine coolant temperature | |
| gauge:electronic. | 17 |
| Engine fan | 230 |
| Engine:idle speed control | 156 |
| Engine knocking | 264 |

| | |
|---------------------------------------|----------|
| Engine oil | |
| changing oil and oil filter | 234 |
| checking and adding | 234 |
| dipstick | 234 |
| disposal | 230, 248 |
| engine oil pressure gauge | 16 |
| filter, specifications | 293 |
| refill capacities | 294 |
| specifications | 233, 296 |
| synthetic oil | 233 |
| “break-in” oils | 5 |
| viscosity | 233 |
| Entry system, illuminated | 73 |
| Exhaust fumes | 160 |
| Extended Service Plan, Ford | 3 |

F

| | |
|-----------------------------------------------------|---------|
| Fan, engine fan, avoiding injury | 230 |
| Federal Communications Commission | 58 |
| Federal Highway Administration | |
| Regulation | 5 |
| Flashers, hazard | 78, 199 |
| Flat tire. | 209 |
| Fluid refill capacities. | 294 |
| Ford Customer Assistance Center | 305 |
| Ford Dispute Settlement Board | 306 |
| Ford Extended Service Plan | 3 |
| Ford Motor Company of Canada | 310 |
| Ford of Canada Customer | |
| Assistance Centre | 310 |
| Foreign registration | 312 |
| Four-Wheel Drive vehicles, special notice | 5 |
| Four-wheeling with Ford supplement | 5 |
| French owner guides, how to obtain | 3 |

| | |
|------------------------------------------|----------|
| Fuel | |
| calculating fuel economy | 268 |
| capacity | 294 |
| choosing the right fuel | 264 |
| comparisons with EPA fuel | |
| economy estimates | 268 |
| filling your vehicle with fuel. | 260 |
| filter, specifications | 293 |
| fuel filler door release lever | 260 |
| fuel gauge | 17 |
| octane rating | 264 |
| quality. | 264 |
| running out of fuel | 267 |
| safety information relating to | |
| automotive fuels | 265 |
| storing your vehicle. | 284 |
| treating emergencies | 265 |
| Fuel cap | 260 |
| removing | 260, 262 |
| replacing. | 260, 263 |
| Fuel filler door | |
| override, manual | 261 |
| remote release | 260 |
| Fuel filter, specifications | 293 |
| Fuel gauge | 17 |
| Fuel pump shut-off switch | |
| engine does not start | 158 |
| starting after a collision | 158 |
| Fuse panels. | 200 |
| Fuses | |
| charts | 200 |
| circuit breakers. | 209 |

G

| | |
|--------------------------------------------|----------|
| Gas cap (see Fuel cap) | 260 |
| Gas mileage (see Fuel economy) | 264, 268 |
| Gasohol | 265 |
| Gasoline (see Fuel). | 260 |
| Gauges, Mechanical | |
| battery voltage gauge | 15 |
| charging system gauge | 15 |
| engine coolant temperature gauge | 17 |
| engine oil pressure gauge | 16 |
| fuel gauge | 17 |
| odometer. | 20 |
| speedometer | 18 |
| trip odometer. | 20 |
| GAWR (Gross Axle Weight Rating) | |
| calculating | 187 |
| definition. | 179, 185 |
| driving with a heavy load | 179 |
| location | 185 |
| Gearshift | |
| automatic operation | 170 |
| column-mounted | 170 |
| gearshift override | 155, 171 |
| locking the gearshift. | 74 |
| positions | 170 |
| shifting the gears | 170 |
| shift-lock | 155, 171 |
| Gearshift:shifting the gears | 170 |
| GVWR (Gross Vehicle Weight Rating) | |
| calculating | 187 |
| definition. | 179, 184 |
| driving with a heavy load | 179 |
| location | 185 |

H

| | |
|-----------------------------------------------|---------|
| Hazard flashers | 78, 199 |
| Headlamps | |
| aiming | 272 |
| checking alignment | 272 |
| cleaning | 281 |
| daytime running lights | 72 |
| replacing bulbs | 272 |
| turning on and off | 71 |
| warning chime | 14 |
| Heating | |
| heating and air conditioning system | 62 |
| rear seat controls | 67 |
| standard heater system | 65 |
| High beams | |
| indicator light | 14 |
| operation | 71 |
| High-mount brakelamp, description. | 72 |
| High-mount brakelamp:location | 72 |
| Hitch | 194 |
| Hood | |
| latch location. | 231 |
| lubrication specifications. | 296 |
| release lever | 231 |
| working under the hood | 230 |
| Hoses, checking. | 243 |

I

| | |
|----------------------------------------------------|---------------|
| Identification Number, Vehicle (VIN) | 300 |
| Idle | |
| relearning | 226, 230, 250 |
| speed | 156 |
| Ignition | |
| chime | 14 |
| positions of the ignition | 74 |
| Indicator lights and chimes (see Lights) | 7 |
| Infant seats (see Safety seats). | 128, 130 |
| Instrument cluster. | 9 |

| | |
|--------------------------------------------------------------|-----|
| Instrument panel | 59 |
| cleaning | 282 |
| registers | 61 |
| Integrated child seat (see Built-in child seat) | 141 |
| Interval wipers | 76 |

J

| | |
|-------------------------------|----------|
| Jack | |
| operation. | 216, 219 |
| positioning | 216, 219 |
| storage | 211 |
| Jump-starting your vehicle | |
| attaching cables. | 224 |
| disconnecting cables. | 226 |

K

| | |
|-------------------------------------|----|
| Keys | |
| key in ignition chime | 14 |
| positions of the ignition | 74 |
| stuck in lock position | 74 |

L

| | |
|---------------------------------------------------|---------|
| Lamps | |
| checking | 272 |
| daytime running light system | 72 |
| hazard flashers | 78, 199 |
| headlamps | 71 |
| high-mount brakelamp | 72 |
| illuminated entry system. | 73 |
| interior lamps. | 71 |
| replacing bulbs | 272 |
| trailer | 195 |
| Lane change indicator (see Turn signal) | 75 |
| Lap belts | 116 |
| Lights, warning and indicator | |
| air bag. | 13 |
| brake | 9 |
| charging system. | 13 |
| check engine | 12 |
| door ajar | 11 |

| | |
|-------------------------------------------|----------|
| Lights, warning and indicator (continued) | |
| engine oil pressure | 16 |
| hazard warning light | 78, 199 |
| high beam | 14 |
| oil pressure | 16 |
| safety belt | 11 |
| service engine soon | 12 |
| turn signal indicator | 75 |
| Load limits | |
| GAWR. | 179 |
| GVWR. | 179 |
| trailer towing. | 181 |
| Lubricant specifications | 296 |
| Lug nuts | |
| standard | 219 |
| tightening sequence. | 216, 221 |
| Lumbar support, seats. | 106 |
| Lumbar support pad | 106 |

M

| | |
|--------------------------------------------------------------------------------------------------------|-----|
| Maintenance schedule and record (see separate Maintenance Schedule and Record booklet) | 3 |
| Maintenance (see Servicing) | 229 |
| Manual transmission | |
| fluid capacities | 294 |
| lubricant specifications | 296 |
| Master cylinder, brakes | 236 |
| Methanol in fuel | 265 |
| Mileage, calculating fuel economy | 268 |
| Mirrors | |
| dual electric remote control | 91 |
| rearview | 91 |
| side view mirrors. | 91 |
| side view mirrors (power). | 91 |
| Motorcraft parts. | 293 |

N

| | |
|----------------------------------------------------------|-----|
| National Highway Traffic Safety Administration | 301 |
| New vehicle break-in | 5 |

O

| | |
|-----------------------------------------------|--------|
| Octane rating | 264 |
| Odometer | |
| description | 20 |
| trip odometer. | 20 |
| Oil filter | 293 |
| Oil (see Engine oil) | 233 |
| Oil viscosity | 233 |
| On-board diagnostic (OBD II) system | 271 |
| Order forms, service information | 25, 50 |
| Overdrive. | 173 |
| Overseas offices | 312 |

P

| | |
|---------------------------------------|-----|
| Parking brake | |
| operation. | 166 |
| warning light. | 9 |
| Parts (see Motorcraft Parts). | 293 |
| PCV valve, specifications. | 293 |
| Power door locks | 88 |
| Power features | |
| door locks | 88 |
| lumbar support. | 106 |
| mirrors. | 91 |
| windows | 89 |
| Power steering | |
| dipstick | 244 |
| driving with power steering | 168 |
| fluid, checking and adding. | 244 |
| fluid, refill capacity | 294 |
| fluid, specifications | 296 |
| servicing | 168 |
| Prop rod, hood | 231 |

R

| | |
|--------------------------------------------------------------------------|----------|
| Radio (see Electronic sound systems) | 21 |
| Rear anti-lock brakes | 164 |
| description | 164 |
| Rear axle | |
| lubricant specification | 296 |
| refill capacity | 294 |
| traction lok. | 177, 254 |
| Rear climate control system | 67 |
| Rear window | 89 |
| defroster | 69 |
| Refill capacities for fluids | 294 |
| Regulations, National Highway Traffic Safety Administration | 301 |
| Remote entry system, illuminated entry | 73 |
| Reporting safety defects | 301 |
| Restraints, safety (see Safety restraints) | |
| adult | 97, 108 |
| child. | 128 |
| infant | 128, 130 |
| Reverse | 173 |
| Roadside assistance | 303 |
| Roadside emergencies | 199 |
| Rotating the tires | 255 |

S

| | |
|--------------------------------------------------------------|----------|
| Safety belts (see Safety restraints). | 108 |
| Safety chains, when towing a trailer | 194 |
| Safety Compliance Certification Label | 300 |
| Safety defects, reporting | 301 |
| Safety information relating to automotive fuels | 265 |
| Safety restraints | |
| adjusting the safety belts | 110, 117 |
| automatic locking mode | 112 |
| automatic locking mode (retractor) | 112 |
| center front lap belt. | 116 |
| center rear lap belt | 116 |
| cleaning the safety belts | 283 |
| extension assembly | 117 |

| | |
|----------------------------------------------|----------|
| Safety restraints (continued) | |
| for adults | 108 |
| for children. | 128 |
| for infants | 128, 130 |
| for pregnant women. | 98, 108 |
| lap and shoulder belts. | 108, 110 |
| lap belt | 116 |
| maintenance | 118 |
| proper use | 108 |
| replacement | 118 |
| untwisting or unjamming the | |
| safety belt | 118 |
| warning light and chime. | 11 |
| Safety seats for children | |
| and air bags | 130 |
| attaching with tether straps | 139 |
| automatic locking mode (retractor) | 112, 130 |
| built-in child seat | 141 |
| in front seat | 130 |
| in rear outboard | 130 |
| in rear seat | 130 |
| tether anchorage hardware. | 139 |
| Seat belts (see Safety restraints). | 108 |
| Seats | |
| adjusting the seat, manual | 97 |
| child safety seats | 130 |
| cleaning upholstery | 282 |
| lumbar support | 106 |
| quick release rear captain's chair | 99 |
| reclining the seat | 97 |
| seatback release. | 97 |
| seat/bed conversion. | 106 |
| Serial number (VIN). | 300 |
| Service concerns. | 304 |
| Servicing your vehicle | |
| precautions when servicing | 230 |
| servicing when you tow | 226 |
| Shift-lock system | 155, 171 |
| Shift positions (see Gearshift). | 170 |

| | |
|--------------------------------------------------------------|----------|
| Shoulder and lap belts (see Safety restraints) | 108, 110 |
| Shoulder belts (see Safety restraints) | 110 |
| Side mirrors | |
| adjusting. | 91 |
| Snow tires and chains | 259 |
| Spare tire | |
| changing the tire | 209, 216 |
| conventional spare | 209, 211 |
| finding the spare | 211 |
| removing the spare tire | 211 |
| storing the flat tire | 211, 219 |
| temporary spare | 210 |
| Spark plugs, specifications | 293 |
| Special notice | |
| E-4WD vehicles. | 5 |
| Specification chart, lubricants. | 296 |
| Speed control | |
| turning off | 80 |
| when towing a trailer | 196 |
| Speedometer | 18 |
| Starting your vehicle | |
| preparing to start your vehicle. | 153 |
| starting a cold engine | 154 |
| starting after a collision | 158 |
| starting a warm engine | 154 |
| starting your vehicle if the battery is disabled. | 222 |
| Steering, power | 168 |
| Steering wheel | |
| locking | 74 |
| tilting | 79 |
| Storage compartments | |
| center console | 92 |
| underseat storage drawer | 107 |
| Storing your vehicle. | 283 |
| Supplemental air bag readiness light | 13 |
| Supplemental Restraint System (SRS) | 122 |

T

| | |
|-----------------------------------------------|----------|
| Tail lamps | |
| bulb replacement | 272 |
| cleaning | 281 |
| Temperature control (see Climate control) . . | 61 |
| Tether anchor installation | |
| (see Child restraints) | 139 |
| Tilt steering wheel. | 79 |
| Tires | |
| changing | 209 |
| checking the pressure | 252 |
| cleaning | 281 |
| inspection and maintenance | 252 |
| replacing | 256 |
| rotating | 255 |
| snow tires and chains | 259 |
| spare tire. | 209, 211 |
| storing your vehicle | 285 |
| tire grades | 256 |
| treadwear | 256 |
| wear bands. | 256 |
| wheel and tire matching. | 259 |
| Towing your vehicle | |
| using wheel dollies | 226 |
| with a tow truck | 226 |
| Traction control | 177, 254 |
| Traction-lok rear axle | 177, 254 |
| Trailer towing | |
| calculating maximum trailer weight. . . | 187 |
| safety chains | 194 |
| trailer brakes | 195 |
| trailer lamps | 195 |

| | |
|-----------------------------------------------------|-----|
| Transmission | |
| automatic operation | 170 |
| fluid, checking and adding (automatic) | 247 |
| fluid, refill capacities | 294 |
| lubricant specifications | 296 |
| Trip odometer | 20 |
| Tune-up specifications (VECI) | 271 |
| Turn signal | |
| indicator lights | 75 |
| lever | 75 |

U

| | |
|-------------------------------------|----------|
| Used engine oil, disposal | 230, 248 |
|-------------------------------------|----------|

V

| | |
|-------------------------------------------------------------|--------|
| Variable interval wipers | 76 |
| VECI (Vehicle Emission Control Information) | |
| decals | 271 |
| Vehicle Identification Number (VIN) | 300 |
| Vehicle loading | 181 |
| calculating the load | 187 |
| understanding loading information | 179 |
| Vehicle storage | 283 |
| Ventilating your vehicle (see Climate control) | 61 |
| Viscosity (see Engine oil) | 233 |
| Voltmeter (see Battery voltage gauge) | 13, 15 |

W

| | |
|----------------------------------------------------|----------|
| Warm engine, starting | 154 |
| Warning chimes | |
| headlamps on. | 14 |
| key in ignition | 14 |
| safety belt | 11 |
| Warning lights (see Lights). | 7 |
| Warranties | |
| basic. | 3 |
| Canada. | 3 |
| radio. | 58 |
| Warranty Information Booklet | 3 |
| Washer fluid | 76 |
| Weight limits (GAWR, GVWR) | 179 |
| Wheel and tire matching | 259 |
| Wheel bearings, lubricant specifications | 296 |
| Wheel dollies (see Towing). | 226 |
| Wheels | |
| cleaning | 281 |
| covers | 216, 219 |
| inspection and maintenance | 252 |
| lug nuts | 216 |
| replacement | 259 |
| Windows | |
| liftgate window. | 85 |
| manual windows, operating | 89 |
| one-touch down. | 90 |
| power windows, operating. | 89 |
| rear, defrosting | 69 |

| | |
|-----------------------------------------------|----------|
| Windshield, washing | 76 |
| Windshield washer fluid and wipers | |
| checking and replacing wiper blades | 251 |
| operation | 76 |
| reservoir | 238 |
| specifications | 239, 296 |
| variable interval wipers | 76 |
| Windshield wipers and washer. | 76 |
| Wrecker towing. | 226 |

Service Station Information

| | | |
|-------------------------------------|-----------|-------------------------------------------------------------------------------------------------------------|
| Engine Size & Type | 3.0 Liter | 12V (2 valves per cylinder), Fuel Injected, 6 Cylinder, 182 Cubic Inch Displacement (CID) |
| | 4.0 Liter | 12V (2 valves per cylinder), Fuel Injected, 6 Cylinder, 245 Cubic Inch Displacement (CID) |
| Fuel | | UNLEADED FUEL ONLY – Octane 87 or higher |
| Fuel Tank Capacity | | 21 gallons (79 liters) |
| Engine Oil | | Use only engine oil displaying the American Petroleum Institute Certification Mark. SAE 5W-30 is preferred. |
| Engine Oil Capacity | 3.0 Liter | 4.5 quarts (4.25 liters) with filter change |
| | 4.0 Liter | 5.0 quarts (4.7 liters) with filter change |
| Engine Coolant Capacity | 3.0 Liter | 11.8 quarts (11.1 liters) |
| | 4.0 Liter | 12.6 quarts (11.9 liters) |
| Tire Size & Pressure | | Tire size and pressure can be found on the Safety Compliance Certification Label. |
| Brake Fluid | | Use only brake fluid that meets Ford's Specification ESA-M6C25-A. |
| Power Steering Fluid | | Use a Motorcraft MERCON® (ATF) power steering fluid. |
| Automatic Transmission Fluid | | Motorcraft MERCON®V (ATF) |
| Hood Release | | Pull handle under the left side of the instrument panel. |