

DENA

DENA
DENA +
DENA + TURBO

Owner's Manual

This manual has been prepared to inform you of how to optimize the use of the vehicle and contains important notes on safety, operation and maintenance. Please keep this manual in your car at all times and be diligent in maintaining it.



In The Name of God



OWNER'S MANUAL
DENA

DEAR BUYER

We're thankful for choosing Iran Khodro product and we congratulate you for this good selection. We hope this new vehicle contributes in happy moments of your life.

This manual helps you enjoy driving. Therefore to have an easy access, it would be advisable to be kept in your glove compartment. The manual is divided into some sections for your convenience, and deals with various aspects of driving or maintenance of the car.

Before driving: Includes seat adjustment, Safety belts, heating and ventilation control system and also every other thing you needed to know in order to settle comfortably.

Driving Controls: explain functions of switches, equipment and precautions.

Maintenance: Includes information about the checks you should carry out regularly.

Note:

Please refer to maintenance and guaranty services manual to know about the vehicle maintenance, regulation & condition of guaranty services and periodic services.

Technical emergencies: Help solve some of unavoidable small emergencies occurring occasionally like replacing lamps fuses or changing wheels.

Technical data: It includes some information about engine, dimensions, capacities and weights.

WARNING, CAUTION and NOTE have special meanings. These special meanings apply except when laws or regulations require that the signal words be used with a different meaning. Pay special attention to the messages highlighted by these signal words:

In the meanwhile consumptive material must be provided through authenticated representatives of IKCO.



WARNING: Indicates a potential hazard that could result in death or injury.



CAUTION: Indicates a potential hazard that could result in vehicle damage.

NOTE: Indicates a serious damage to your vehicle in the case of not paying attention to the warning and caution signals.

Important Point: The specification of each vehicle will vary according to its type. Therefore some information of this manual may not be true about your vehicle. For any more information, you can consult with IRAN KHODRO dealers.

Information about other varieties of this product have been mentioned in this manual and denoted by asterisk (*).

*If equipped

DENA AT A GLANCE 1

BEFORE DRIVING 2

DRIVING 3

MAINTENANCE 4

TECHNICAL EMERGENCIES 5

TECHNICAL DATA 6

INDEX 7

Quick Review Log

LOCKING / UNLOCKING DOORS	28-31
PRE-TENSIONER AND POWER LIMITER SEAT BELT	21 & 46
CHILDREN SAFETY	38-43
HEATING AND AIR VENTILATION	55-58
INTERNAL EQUIPMENT	61
BOOT ACCESS	59-62
SUN ROOF *	63
AUDIO EQUIPMENT INSTRUMENT PANEL ON STEERING WHEEL	65
ALARM SYSTEM	68-77
DIGITAL DISPLAY LCD ON FRONT DASHBOARD	78-79
CRUISE CONTROL *	78
ENGINE POWERING ON AND DRIVING	81
REAR WARNING SYATEM	83
BRAKES	92-94
REAR VISION CAMERA *	84
TURBOCHARGER	89
LIGHT AND INDICATORS	86
AIRBAG	95-98
PERIPHERAL AIR BAG	96
MAINTENANCE AND INSPECTION OF IMPORTANT ITEMS	100
ENGINE COMPARTMENT	102-110
APPLIED INSTRUCTIONS (WHEELS REPLACEMENT, VEHICLE TRANSFER, BATTERY SERVICE AND MAINTENANCE, FUSES & LAMPS REPLACEMENT)	118-138
TECHNICAL INFORMATION (TECHNICAL INFORMATION OF VEHICLE'S ENGINE, FUEL CONSUMPTION AND VEHICLE DIMENSIONS)	145-153

*If installed on your vehicle

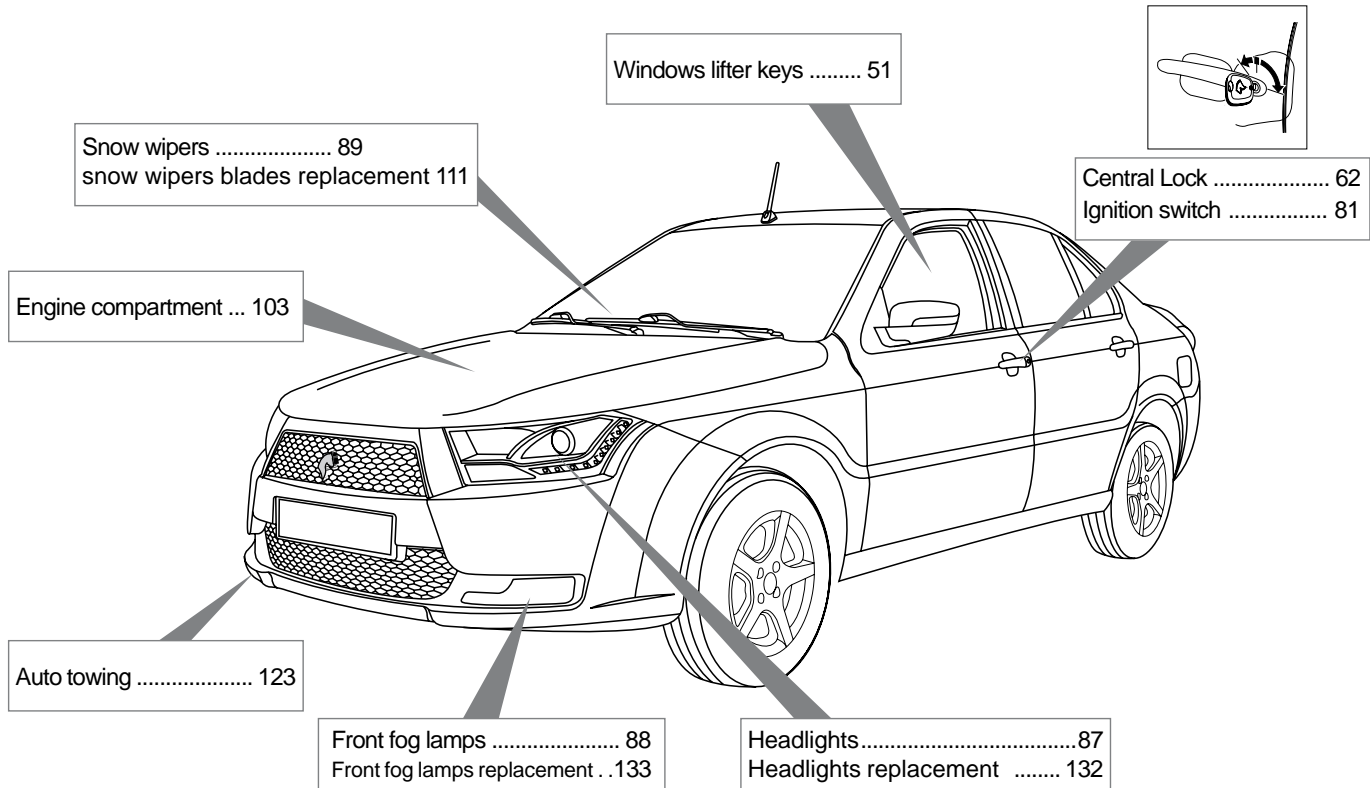

PICTORIAL LIST

Dena⁺

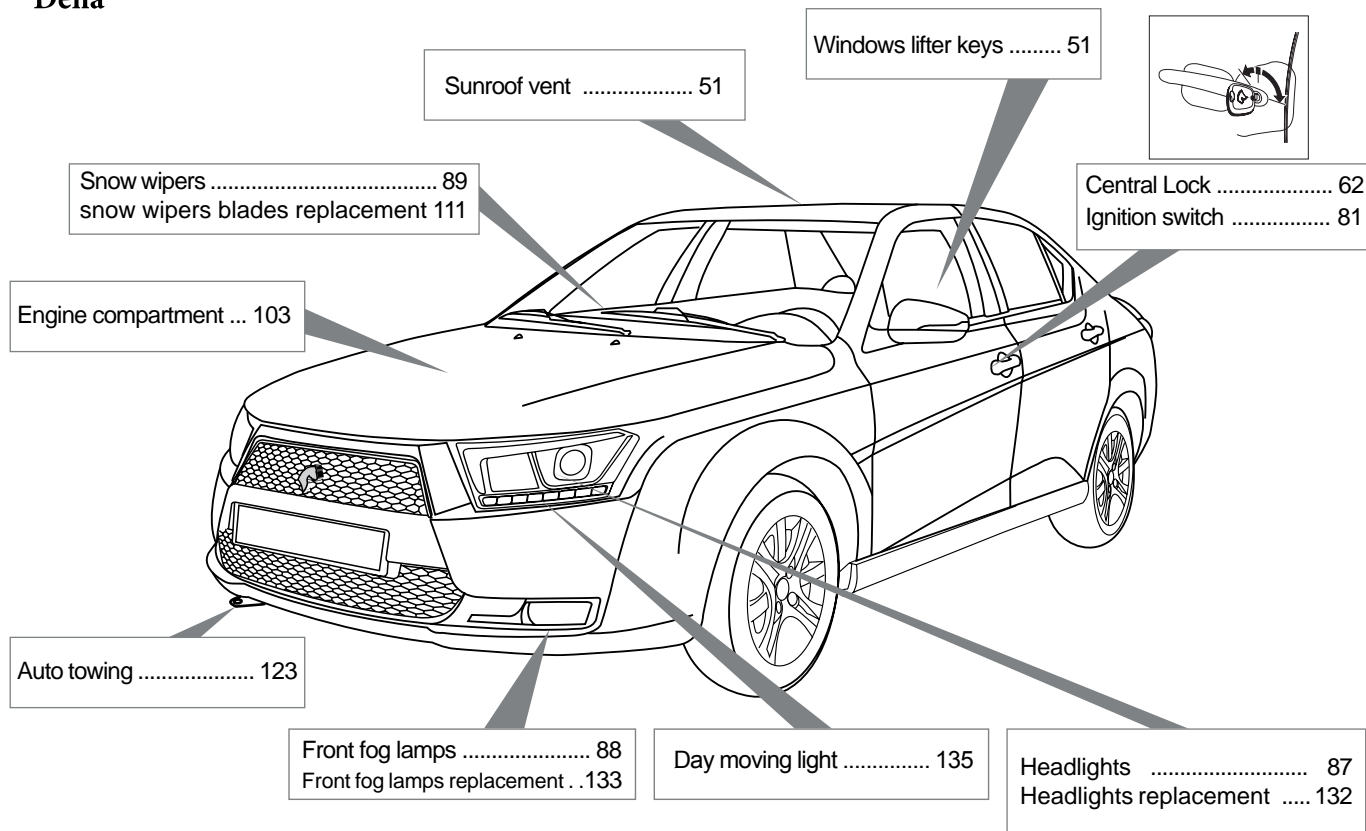

*If installed on your vehicle

Dena

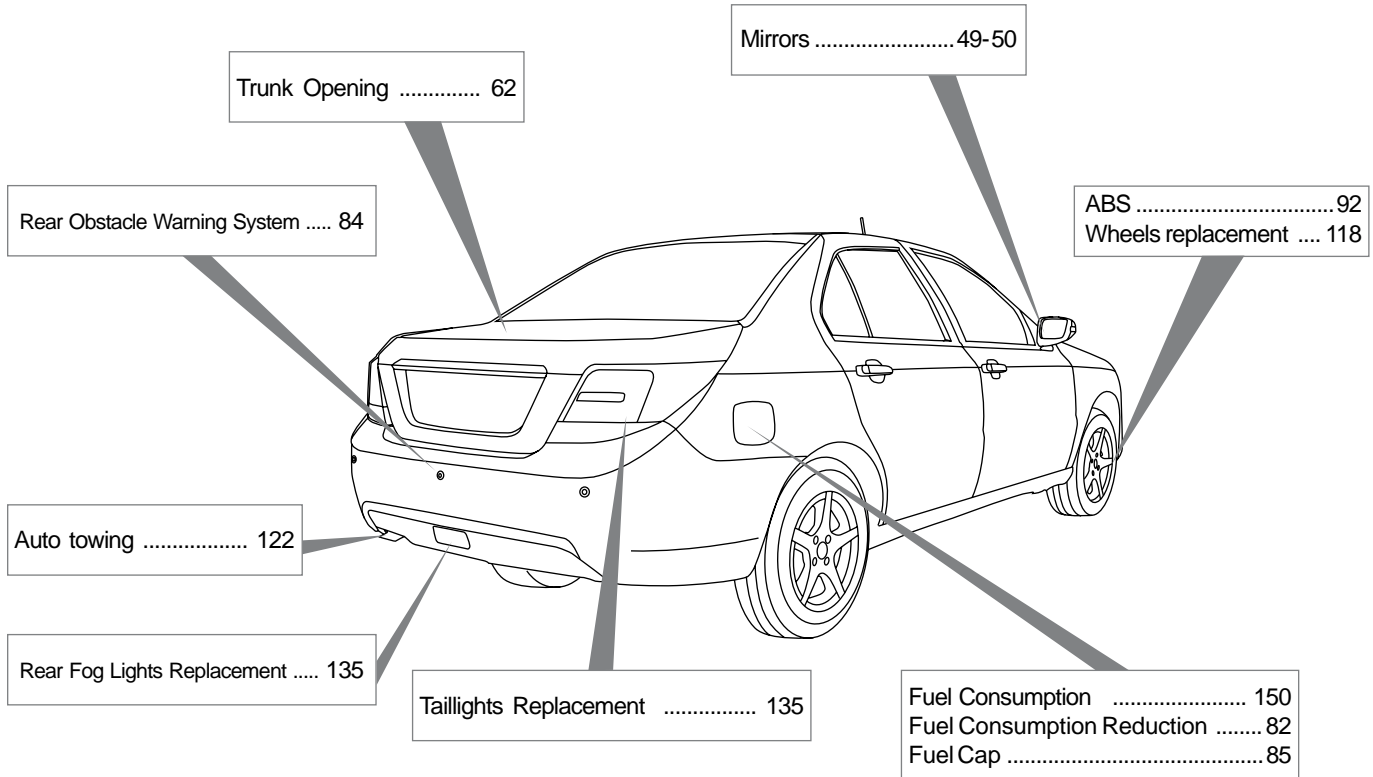

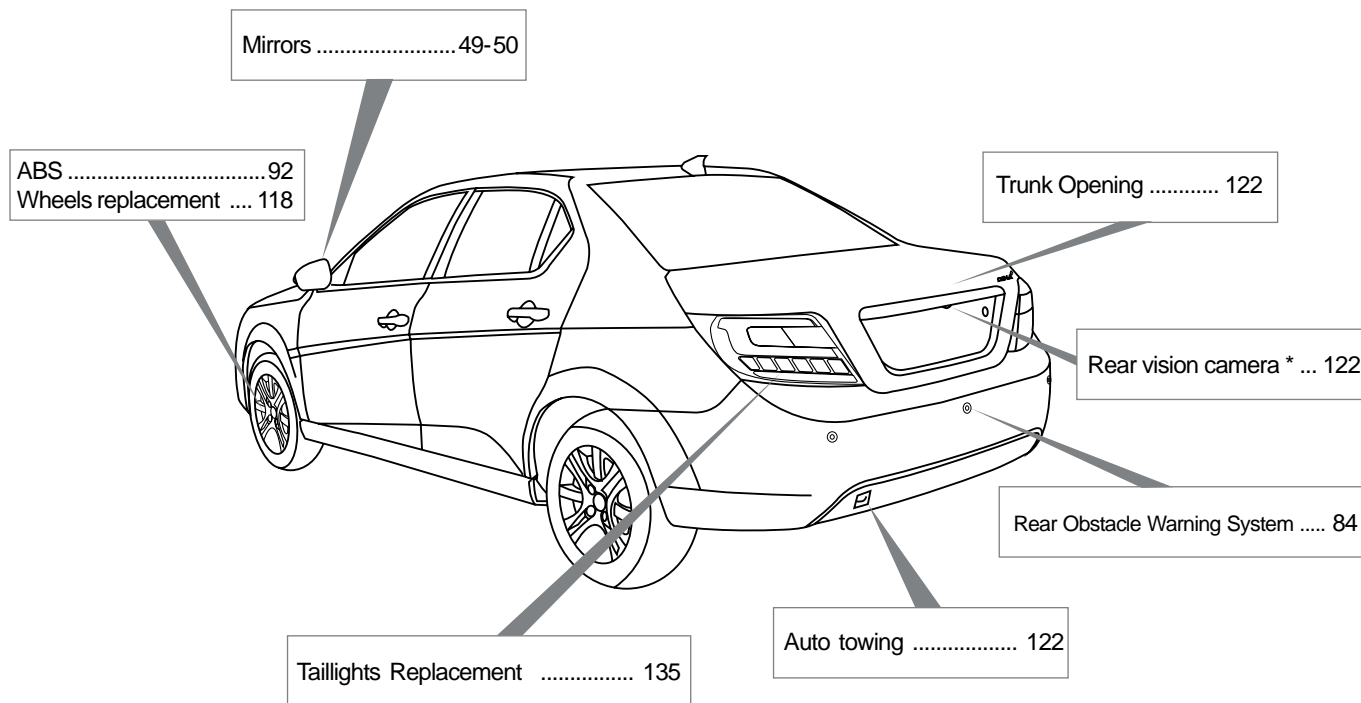

*If installed on your vehicle

Engine Compartment

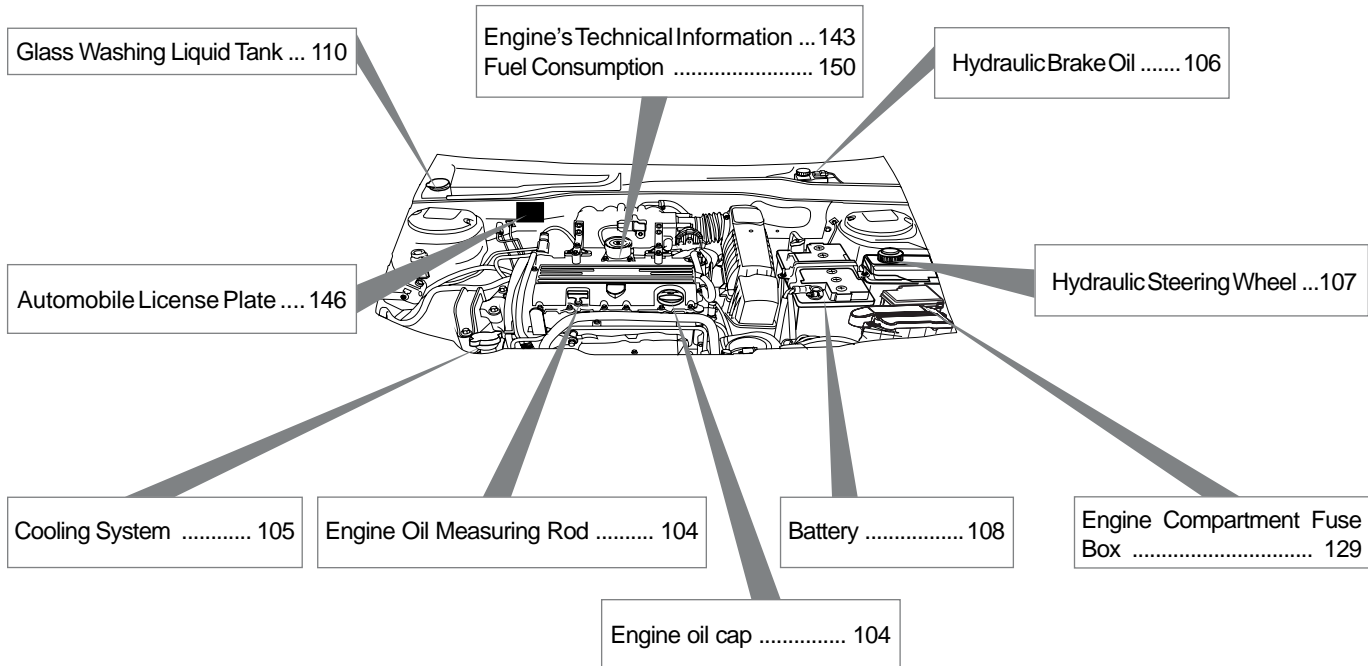

* turbo

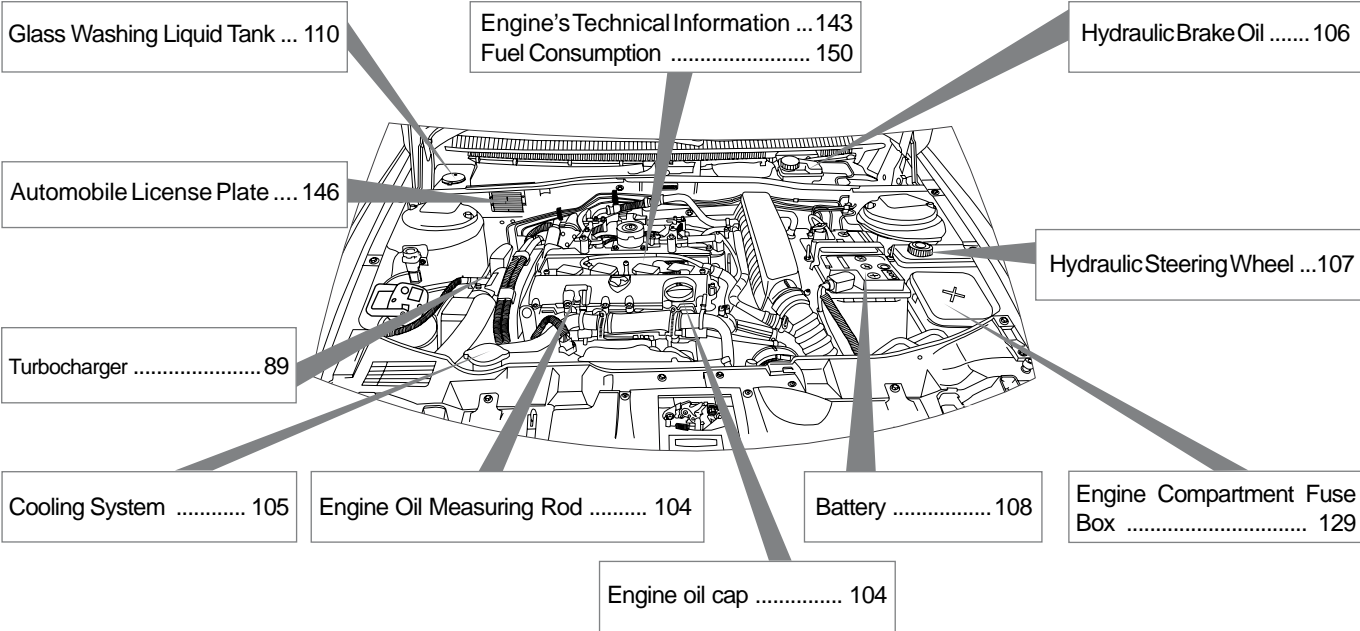

*If installed on your vehicle

1 YOUR VEHICLE AT A GLANCE

CONTROLLERS	12-13	AIR BAG	22
KEYS	14	TRUNK ACCESS	23
WINDOWS REGULATOR KEYS	15	CHILD SAFETY LOCKS	23
ELECTRIC MIRRORS	16	STEERING WHEEL ANGLE ADJUSTMENT	24
IMMOBILIZER SYSTEM	17	ENGINE COMPARTMENT OPEN/CLOSE	24
INDICATOR LEVER AND SNOW WIPER	18	TYPE OF FUEL	25
SEATS	19	HANDS FREE MOBILE	26
HEATING AND VENTILATION	20	INTELLIGENT SPEED CONTROL (CRUISE CONTROL) ..	26
PRETENSION SEAT BELT	21		

*If equipped

YOUR VEHICLE AT A GLANCE

1

CONTROLS:

1. Automatic Air Conditioning System
2. Passenger Air Bag
3. Trunk Opener Key
4. Flasher Key
5. Central Lock Key
6. Glass Washer and Snow Wiper Keys
7. Dashboard Digital Display
8. Engine Door Lever
9. Air Vents
10. Radio / CD
11. Ashtray and Lighter
12. Ignition Switch
13. Rear Windows Locker Keys
14. Windows Regulator Keys
15. Side Mirrors Adjustment
16. Audio Equipment instrument panel on the Steering Wheel
- 17- Sunroof adjustment key * .
- 18- Place for keeping glasses*
- 19- Control key for internal light turning on/off while doors are getting open*.
- 20-cruise control keys on steering wheel.

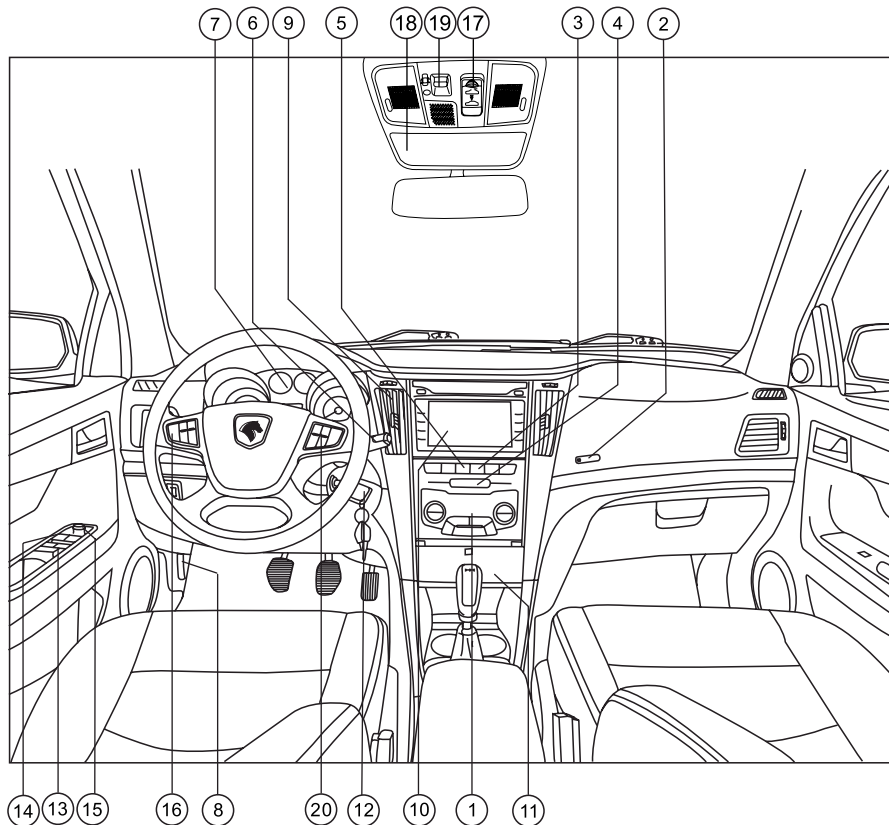

*If installed on your vehicle

CONTROLS:

1. Gear Level
2. Passenger Air Bag Inactivating Keys
3. Indicator and Horn Lever
4. Air Vents
5. Hand Brake
6. Driver's Air Bag
7. Steering Wheel Adjustment Lever
8. Headlights Height Adjustment

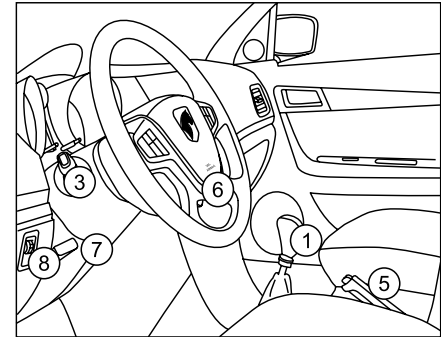
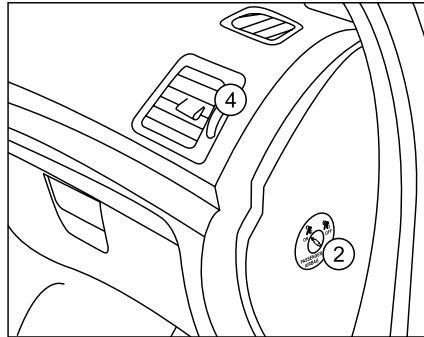

YOUR VEHICLE AT A GLANCE

1

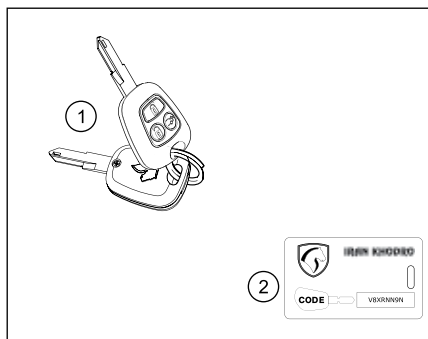

Key set:

The following keys will be delivered to you:

1. Two radio remote switches equipped with trunk opener key
2. Key ID plate

There inserted a number on this plate which will be needed in case you want to replace your key. Hence, keep it in a safe place outside your vehicle.

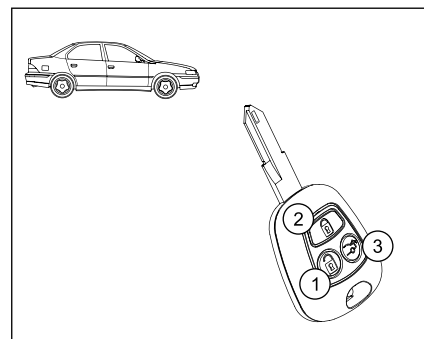

Locking/unlocking via Remote Control

Keep the remote control on your vehicle's side

Press button 1 to unlock

Press button 2 to lock

Press button 3 to open the hood

NOTE:

There is possibility of breakage for internal parts of the remote controller in case of severe impact and subsequently not functioning of the anti-theft system (immobilizer).



WARNING

Keep the remote control or its batteries out of reach of children, because Eating the batteries will result in death. Refer to a treatment center in case of eating batteries.

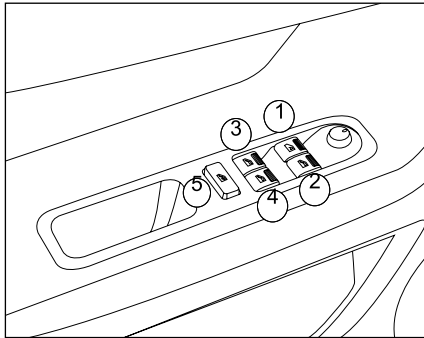

ELECTRICAL WINDOWS LIFTER:

1) DRIVER'S ELECTRICAL WINDOWS LIFER

MANUAL MODE:

Press or pull the key briefly. As soon as the application of pressure on the key ceases, the window will stop.

- AUTOMATIC MODE:

By pressing or pulling the key once, the window will open or close completely. Lifting the windows are possible when the engine is on and lowering them is possible in all different positions of ignition switch.

- 2) Passenger's electric window switch
- 3) Left back seat electric window switch
- 4) Right back seat electric window switch

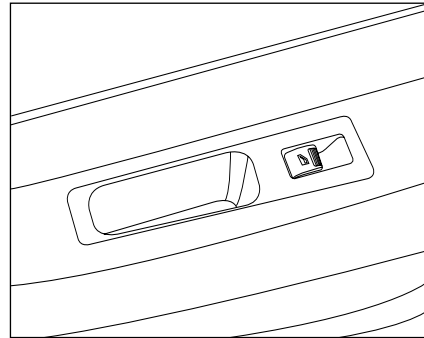

5) Back seats electric window lock switch
When the driver locks the back seat windows by this key, the relevant windows will not function

GLASSES KEY

Each passenger is able to open/close his/her side windows by means of this key.

AUTOMATIC UNLOCKING THE WINDOWS *

This system causes all windows to be checked and to be lifted up if any one of them are in low position, when all doors are locked through remote controller.

The doors are locked with one time pressing the lock button on the remote control, and the second pressing on the same keys, the glasses will be lifted automatically as per the following respect:

The driver glass, passenger glass, rear left and right window.

This security system makes it free of risk of forgetting the lifting windows and causes the driver leave the car comfortably.

YOUR VEHICLE AT A GLANCE

1

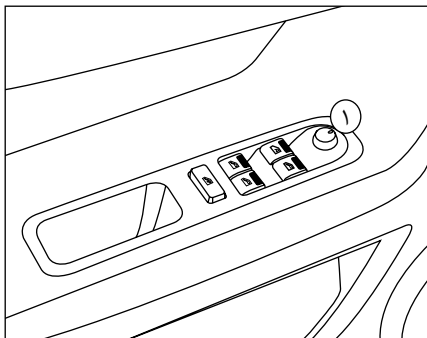

Electrical mirror adjustment

Turn the key no.1 towards the left or right. Then adjust the mirror towards up, down, left or right by pressing the key no.1

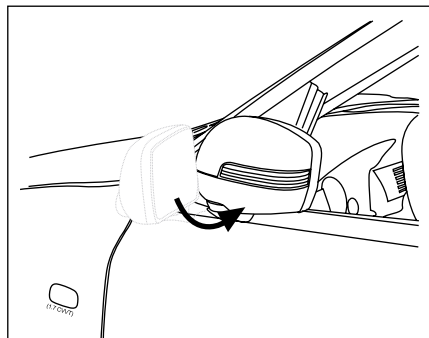

Electrical folding mirrors

These mirrors will be closed without any need to press any key, When the switch is off and the doors are locked, the mirrors will be closed by pressing of the lock key with in 10 seconds open the mirror ; it's just sufficient to press open key on remote controller.

If the vehicle is off;then the mirrors are locked and unlocked by the remote controller.

Folding mirrors are locked and unlocked by keys on the doors panel; in all different positions and situations of ignition switch.



WARNING

Never try to fold the mirrors by hand in order to avoid damaging their electric folding motor.

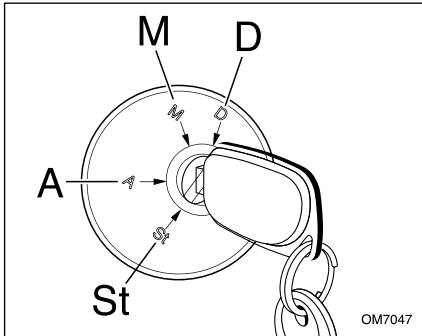

Ignition Switch

Four different status is defined for ignition switch:

- ST Off, the switch is off.
- A The switch is on, but only electrical accessories function.
- M Ignition switch is on
- D Ignition switch is on (start)

CAUTION

There is possibility of breakage for internal parts of the remote controller in case of severe impact and subsequently not functioning of the immobilizer.

Steering wheel lock

Turn the steering wheel smoothly while turning the key before starting the engine, if necessary.

It is advised to push the clutch while you are trying to start in order to make starting operation easier for the vehicle.



WARNING

- Do not move the vehicle before engine warm up.
- Do not start the engine in closed space.
- Do not change the steering wheel lock system.

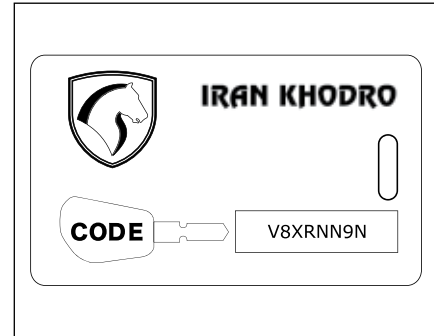

Vehicles anti-theft security system (immobilizer)

This system checks up the engine's electrical system by seconds after engine is off, so that turning the engine on will not be at all possible unless by original keys. Copying the key blade is not enough to make it possible to turn on the engine. You shall refer to authorized branch offices to prepare the appropriate keys.

YOUR VEHICLE AT A GLANCE

1

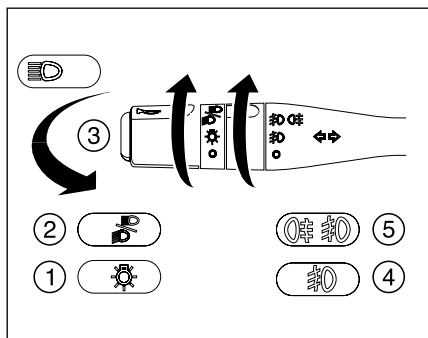

Lights lever, indicator and horn lever

1. Dipped head lamp, tail lights and dashboard display
2. Front beam light
3. Front headlight
4. Front fog light
5. Front/back fog lights

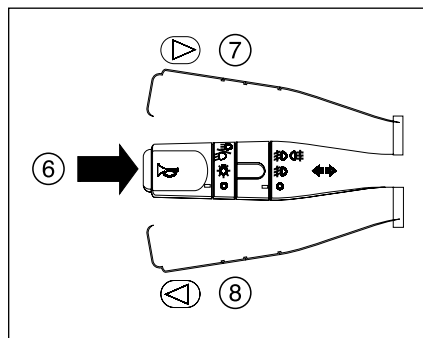

6. Horn
7. Right indicator signal light
8. Left indicator signal light

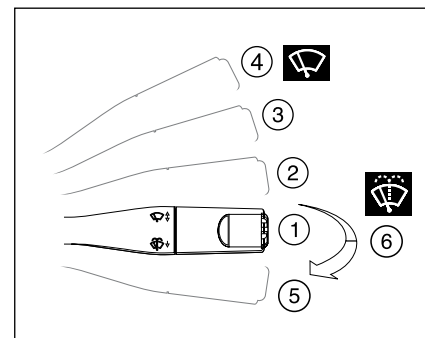

Snow wipers and glass washer

1. Off
2. Timer snow wiper
3. Slow snow wiper
4. Rapid snow wiper
5. Single cycle wiping
6. Glass washer (just pull the lever towards driver)

Electric seat:

1. Seat's back angle adjustment key

2. Seat's floor angle adjustment key *

The icon  is visible ,if your vehicle is equipped.

3. Seat's height adjustment key

4. Seat's rail adjustment key

5. The head rest is capable of the followings:

- Adjusting the height.
- Rotation on forwards and backwards.
- Getting opened and on forward and being closed backwards in some models only. *

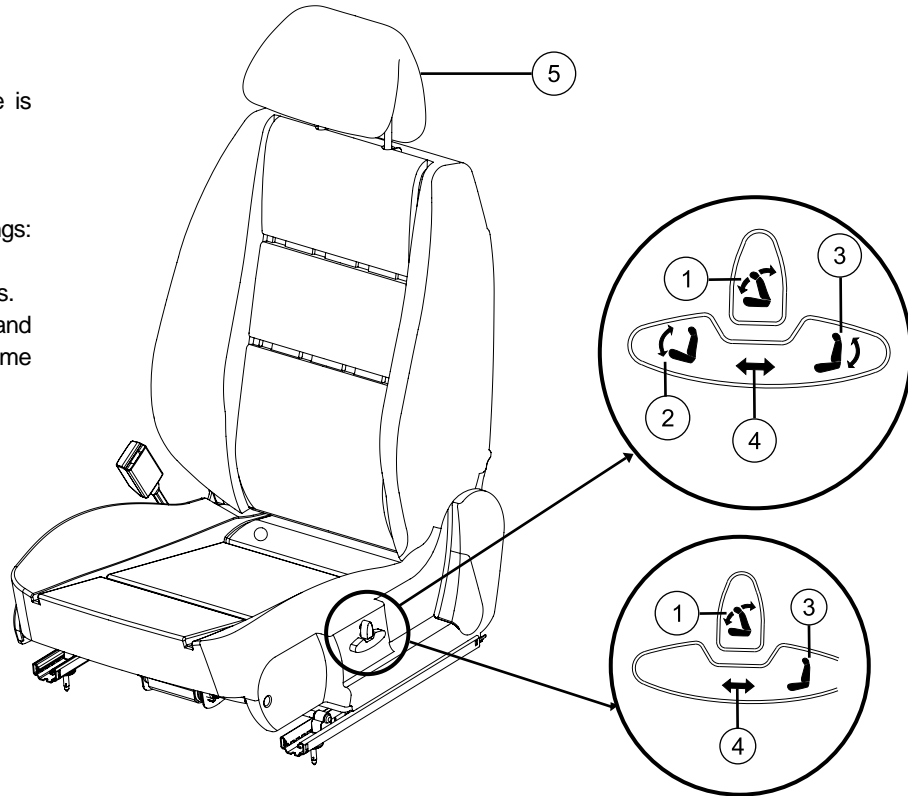

*If your vehicle is equipped

YOUR VEHICLE AT A GLANCE

1

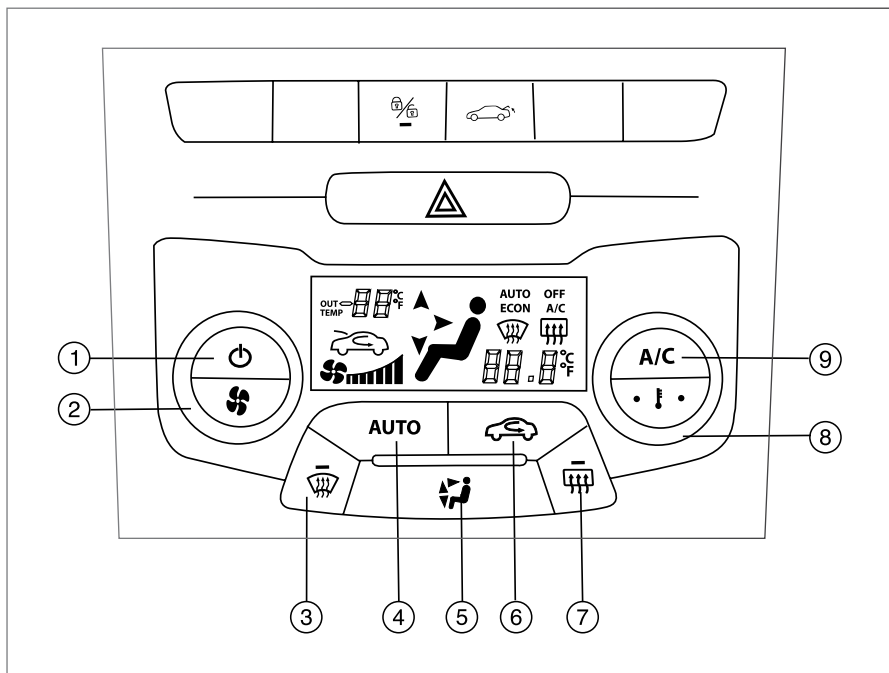

Automatic ventilation

1. Air vent turn on/off
2. Turning the volume to decrease/increase fan speed
3. Turning on windshield heater
4. Automatic adjustment of vent system
5. Selection of air vent direction
6. Control of air entrance resources
7. Turning on rear glass heater
8. Turning the volume to decrease/increase the temperature
9. Turning on the cooler

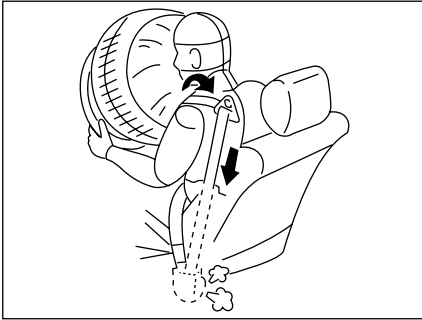

Pretension seat belt

The seat belts and airbag systems will function only in case of severe collision from front side. Actually, they are not designed to alleviate the collisions from back, side, overturn and light accidents.

The pretension system of seat belt operated just once, in this case, i.e. when the air bag operates, you shall replace the seat belt through referring to an authorized branch office of IRAN KHODRO CO.

Seat belts force reducers:

This mechanism is designed to reduce the forces of seal belt to the passenger's chest.



Caution

Please fasten the seat belts as tight as enough to ensure its operation. The pretension system of seat belts will operate in proportionate to the force and direction of clash simultaneously with the air bags. In case each of above operations fails or system failure, the warning light of air bags will turn on.

In order to ensure more safety, always keep the front seat belts as fasten, hence, the air bags will have the best performance.

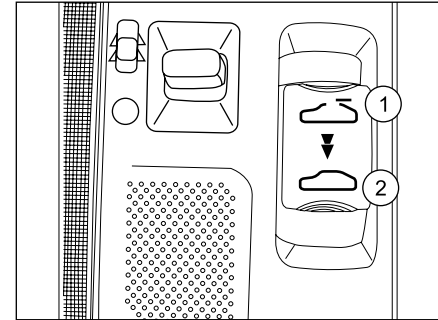

Sunroof *

- 1- Pull the key towards the rear to open the sunroof until your desired extent , then leave it.
- 2- Press the key towards the front to close the sunroof until your desired extent ; then leave it

*If your vehicle is equipped

YOUR VEHICLE AT A GLANCE

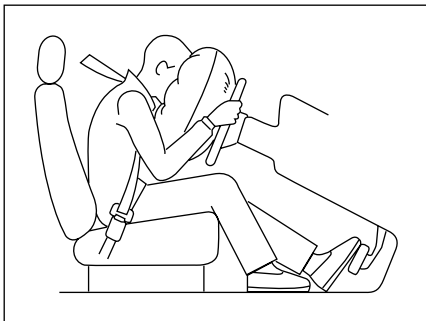

1



Air bag safety

Your vehicle is quipped with Air bag in addition to the pretensioner seat belt.

The Air Bag is activated and protecting all passengers soon after the accident.

When the ignition switch is turned to the "ON" position, air bag indicator on the instrument cluster   gets on and will get turn off again after blinking for 6 times.

Please refer to the authorized representative of IKCO, in case of observing any changes in indicator functions.

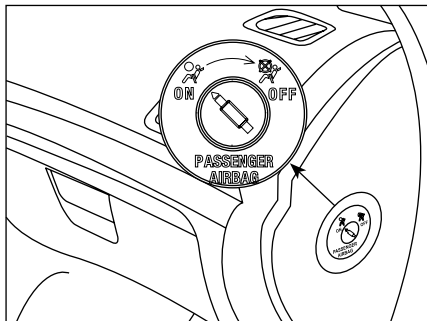

Disabling of the passenger air bag

Disable Key of the passenger air bag is located on lateral side of dashboard section and provides the possibility of activating or inactivating passenger air bag.

The warning light of deactivation mode is turned on, on instrument panel , if the Air bag is deactivated.



WARNING

Enabling or disabling front passenger air bag Should be done, when the vehicle is in off position.

The relevant warning light of deactivation must be turned off  Immediately after reactivating the Air bag.



WARNING

In the event of an accident, there is serious injuries for driver and passengers, if they don't wear a seat belt bend forward, or are positioned out of the chair.

Holding the driver's hand on the blades or central parts of the steering, placing legs on the dashboard and being too close to the air bag, will cause injury to the passengers in the accident while creating functional impairment of safety system.

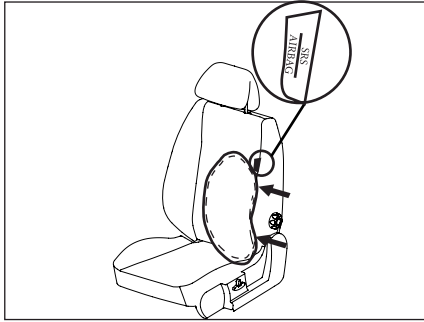

Lateral Air Bag

Lateral air bag is mounted on the side of driver and passenger's seats on which "SRS AIR BAG" is visible.

Lateral air bag is operates while there is an accident from the lateral side and its correct function depends on proper fastening of the seat belts.

If the lateral air bags function once during an accident; they must be changed through authorized dealer of IKCO.



WARNING

In case of one operation of the airbag system, all of its components shall be replaced by authorized IRAN KHODRO's experts.

Mounting of any slip or casing on seats equipped with the air bags are extremely prohibited.

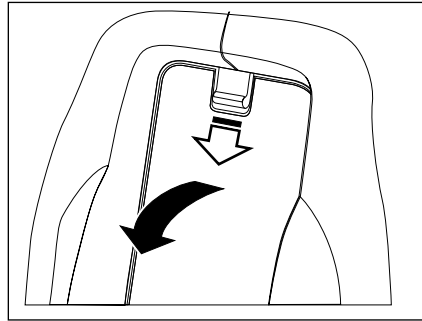

Access gate of the Bonnet

This is designed beneath the elbow part and is for transferring long objects like ski wood, in a way that some part of it is located in hood and the rest on rear seats, or for cases like when accessing the hood is necessary from inside the vehicle.

Pull the elbow down and release its clamp to pull it down, so is will be lied on the elbow.

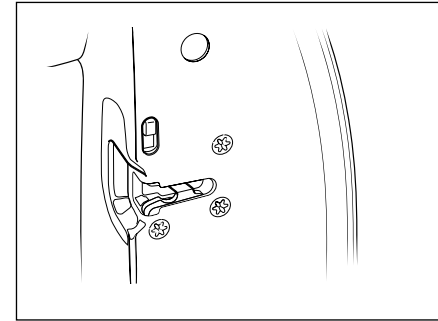

Child's safety locks

This lock mechanism is designed on rear seats, beneath the main locks, which prevents opening doors from inside the vehicle and operates independently in respect of central lock system.

YOUR VEHICLE AT A GLANCE

1

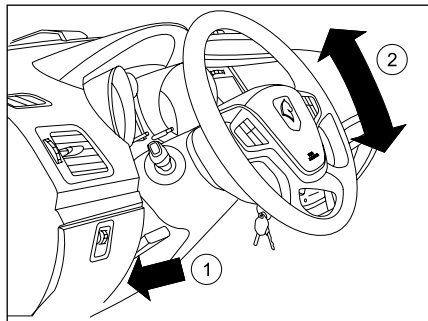

Adjusting the Steering Wheel's angle

First adjust the angle of steering wheel according to your body position and make sure that dashboard gate lights are clearly visible, and then fasten the steering wheel in this position.

To do that:

1. Pull down the steering wheel adjustment lever to release it from lock mode.
2. Then adjust its angle and pull it up to fasten in appropriate location.

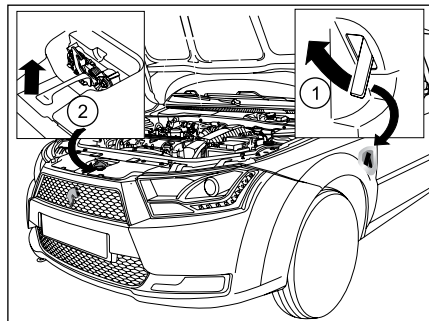

Opening the Engine compartment

1. Inside the vehicle (driver's side), a releasing lever is designed to open the engine's compartment. First, push the lever, then go in front of vehicle and pull up the bonnet.

2. Pull the safety clamp up to be able to open it.

Closing the Engine Compartment

Fasten the compartment rod on its appropriate side and move its door down, in this case you shall hold its door in 30 cm height and let it be released to close the door.



WARNING

Avoid adjusting the angle of steering wheel on move, it is so dangerous.

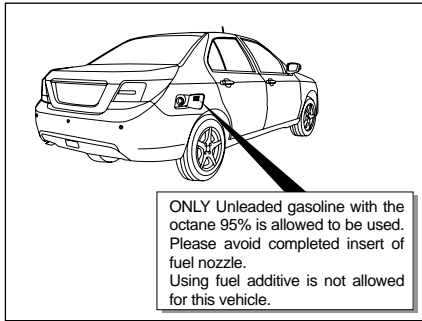

Type of fuel

ONLY Unleaded gasoline with the octane 95% is allowed to be used in your vehicle, OR, internal components of the engine may be severely damages, and losses of ignition and impact may occur.



WARNING

Neglecting using unleaded gasoline will cause severe damages to the vehicles catalyst. AVOID adding any additive with standard fuel.

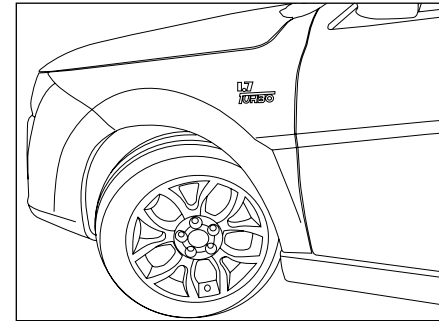

1

Turbocharger is one of the advanced technologies in today's inter combustion engines. This system is using the smoke or the energy of hot gases as an engine output and compresses filtered air through circulation of turbine blade and by a compressor blade connected to the turbine.

Then it causes increase of engine power significantly and also reduction of the fuel consumption through entrance of compressed air to the engine and subsequent cooling it in intercooler.

YOUR VEHICLE AT A GLANCE

1

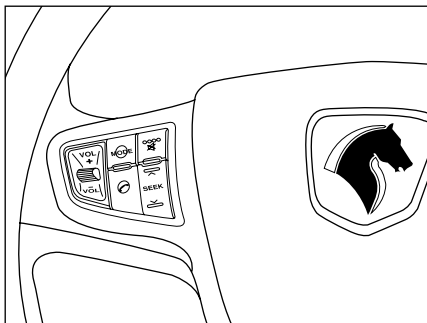

Hands Free mobile with Bluetooth technology

Having been your vehicle equipped with hand free mobile Bluetooth technology, you will not be obliged to answer the phone by hands, even if your phone is located on your pocket or bag, answer/reject key is designed on the related panel designed on steering wheel.

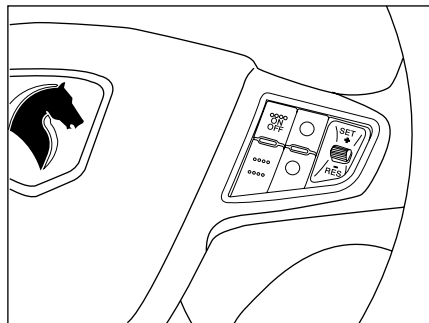

Intelligent speed control (CRUISE Control)*

When cruise control is ON, the driver will be able to control the speed by means of related keys to increase or decrease the speed, the cruise control system will be inactivated as soon as the driver pulls brake or clutch pedals, so controlling the speed will be again performed by the driver.

*If equipped

2 BEFORE DRIVING

DOORS OPENING/CLOSING	28-31	WINDOWS LIFTERS	51-53
VEHICLES ANTI-THEFT SYSTEM (IMMOBILIZER) .	32	INSIDE LIGHTS	54
SEATS	33-37	ROOF LIGHT TIMER	64
CHILDREN SAFETY	38-42	INTERNAL EQUIPMENT	59-62
SEAT BELTS	44-45	STEERING WHEEL	63
PRETENSION SEAT BELT	46	SUNROOF
FIREFIGHTING CAPSULE	47-58	HEATING AND VENTILATION	54-58
MIRRORS	49-50	ALARM SYSTEM	65

*If equipped

LOCKING / UNLOCKING

2

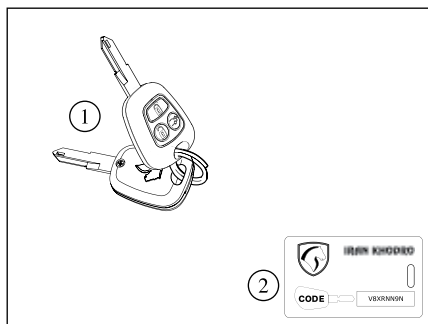

Key set:

The following keys will be delivered to you:

1. Two radio remote switches equipped with trunk opener key
2. Key ID plate

There inserted a number on this plate which will be needed in case you want to replace your key. Hence, keep it in a safe place outside your vehicle and never put this in the vehicle.

NOTE

Pressing the keys consecutively with short pauses between will ceases their operation for 20 seconds.

Locking/unlocking via Remote Control

Keep the remote control on your vehicle's side

Press button 1 to unlock (alarm system will turns off)

Press button 2 to lock (alarm system will turns on)

Press button 3 to open the hood (press this key twice with a bot pause between to open the hood)

Automatic door locking

In case of unlocking doors with the remote control, and not opening the doors for a determined time *, the doors will be again locked automatically and alarm system will be activated. This mechanism is designed to provide safety in case of inadvertent press of unlock keys by the remote control.

In case the vehicle speed exceeds 10 Km/H, the doors will be automatically locked at the move.

Activating/inactivating of this mechanism is possible by pressing and holding central lock key for 5 seconds.

Automatic door unlocking

In case of accident and operation of airbag system, the doors will be automatically opened.

NOTE

There is possibility of breakage for internal parts of the remote controller in case of severe impact and subsequently not functioning of the immobilizer.

1. This time is adjustable by troubleshooter systems existing in IRAN KHODRO offices.
2. This mechanism is able to be inactivated by IRAN KHODRO authorized offices.

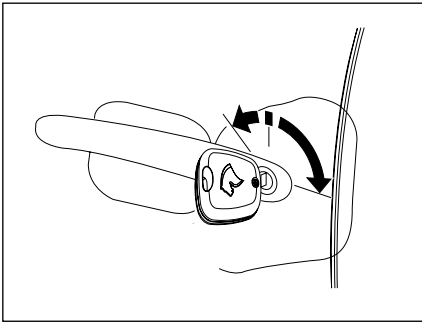

Locking/unlocking with keys

Make use of keys to lock or unlock the central locking system, insert the keys on lock hole of driver's door and turn it right to lock, and turn it left to unlock, this locking/unlocking action will be applied on all doors simultaneously including those of doors, hood, fuel door. Unlocking operation will be also applied on all doors simultaneously.

NOTE

In case of locking through remote control, and you unlock the doors mechanically by keys, the alarm system will function.

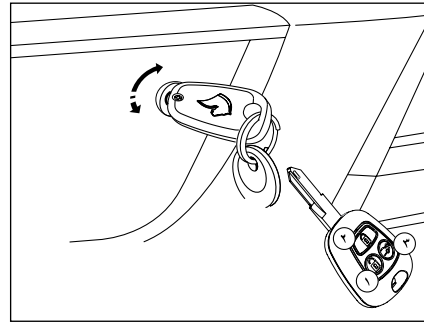

**Locking/unlocking the Hood
By remote controller**

Keep the remote control on direction of radio control and press the key 3 to open the hood (pressing twice with a short pause between will open the hood)

In case of activating door locks with remote control, accessing the hood is possible providing that you close the hood in 30 seconds, OR, the alarm system will function, hence, you'd better to unlock the vehicle through remote control, then take action to open the hood (pressing key 1)

To lock, just by closing the hood, the accessibility to the hood will be limited.

By key :

The booth will be opened by turning of the key toward right inside the switch lock .

The booth won't be in access just by locking it.

LOCKING / UNLOCKING

2

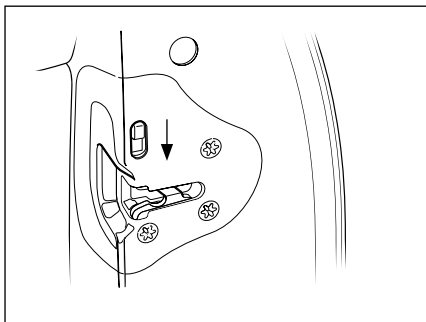

Children safety locks

These lock keys are designed beneath the main lock keys on rear doors, which prevents the possibility of opening doors from inside the vehicle. This mechanism functions independently in respect of central locking system.

Pull the clamp down to activate this child safety locks.

Safety tips to prevent vehicle theft

Observe the following safety tips even when leaving the vehicle for seconds to prevent theft

1. Always keep the windows completely closed.
2. Pick up the antique objects from inside the vehicle or hide them in the boot.
3. Do not leave the keys inside the vehicle.
4. Lock the steering wheel (turn the steering wheel a bit while the engine is OFF, to lock the steering wheel).
5. Lock all the doors.

Make use of your own security considerations in addition to above tips to prevent vehicle theft.



WARNING

Avoid parking your vehicle in solitude places.
Avoid parking your vehicle in so dark places.
Never leave the vehicle docs or keys inside the vehicle.
Make use of your private parking lot if possible, and pick the keys up with yourself when leaving the car.

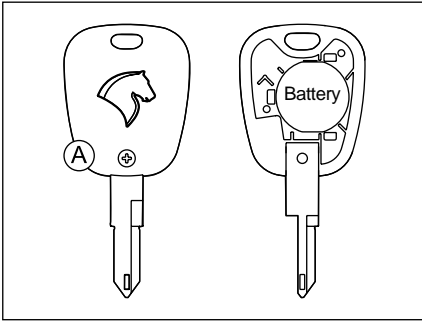

Replacing the remote control battery

Replace the battery of remote control if the key doesn't function.

To replace the battery:

Open screw A, and open the frame by a slow force between the gaps, then replace the battery with an authorized one, i.e. CR 2032

NOTE THAT

The central locking system operates even in case the battery does not have enough charge. Avoid using used batteries if possible.

*If your vehicle is equipped



CAUTION

Never throw the used batteries in the nature, you shall give them to authorized offices to collect and recycle them.

Keep the remote control and its battery out of reach of children, because swallowing the battery will be result in death. If it happened, refer to treatment center as soon as possible.

ANTI-THEFT SECURITY SYSTEM (IMMOBILIZER)

2

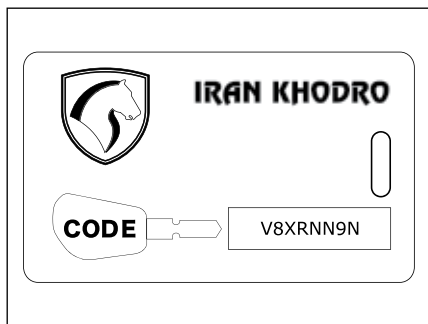

Vehicle's anti-theft security system (Immobilizer)

Having been equipped with the security system, the vehicle will be only turned on by two ignition keys delivered to the customer.

NOTICE

Copying the key blade will not be enough to have appropriate functionality; the keys shall be copied by IRAN KHODRO authorized office through diagnosis systems.

Pay attention to the following tips for a better vehicle maintenance:

1. Your key is designed with an electrical chipsets including code information,

Therefore, avoid putting your keys in high magnetic and electrical forces areas.

2. A card as the present figure will be delivered to the vehicle's owner at the time of vehicle delivery.

Having this card is necessary at the time of replacing keys, copying them, replacing electrical unit of immobilizer, ECU unit, together with ownership deeds, and copying is allowed from 2 to 5 sets. So, keep them in safe mode together with vehicle deeds.

This is to be mentioned that, the above operations will not be possible without above card, in that case, all the system shall be replaced with a new one and all costs will be borne with the owner.



WARNING

- The security system of your vehicle is equipped with is deemed as one of the best security systems causing high safety and security without any special action, but this matter shall not lead in owner's negligence in security considerations.
- Any kind of system repair and modification including those of e-box, wiring, etc., is forbidden.

ATTENTION

This system analyzes the E-system after engine is OFF, so that prevents starting engine with non-original keys. Severe impact or remote control fall may cause in remote control break down and lack of appropriate operation of immobilizer.

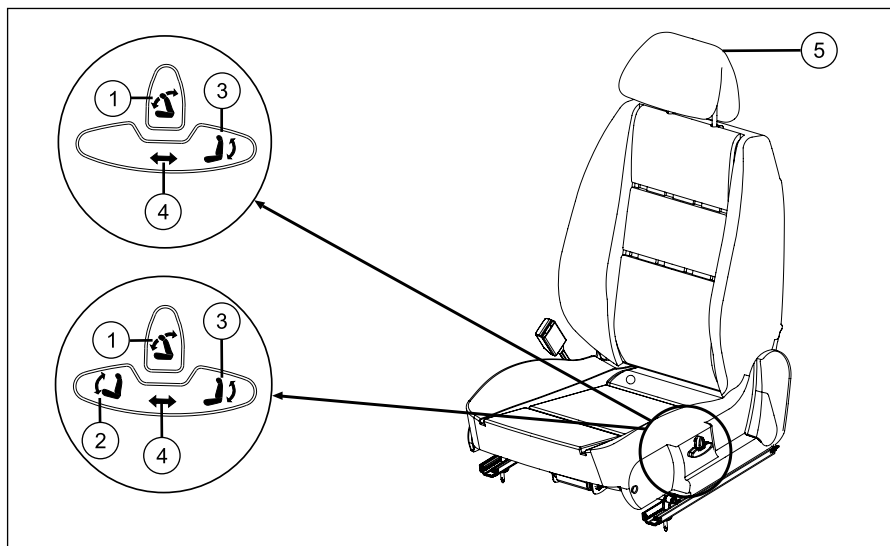

Electric seat

1. Seat's back angle adjustment key
2. Seat's floor angle adjustment key *
3. Seat's height angle adjustment key
4. Seat's rail angle adjustment key

5. Head rest has got the following capabilities :

- Height adjustment .
- Rotation towards front and back.
- Getting open towards the front and getting closed towards the back in some models.*



CAUTION

- Make sure that back passenger's foot is not located beneath the seat when you are trying to adjust its angle.
- Never let an object be placed near or on the driver's floor, because it may move beneath the pedals and create serious risks.
- Avoid adjusting seats setting when the vehicle is moving.

2

*If your vehicle is equipped

SEATS

2

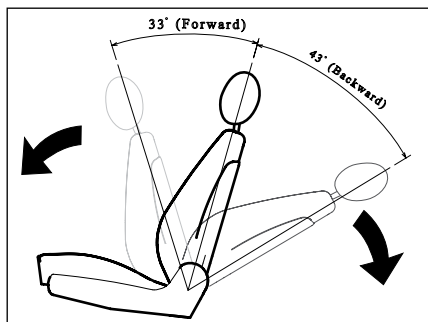

1. Adjusting seat's back angle forward/backward:

 It's just enough to press the related key to move and adjust your seat forward or backward.

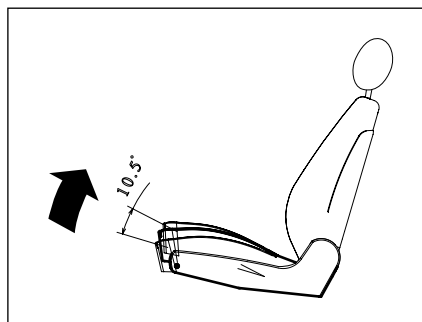

2. Adjusting seat's floor angle

 Press and hold the related key upward downward to adjust this floor angle.



CAUTION

- The seat belts have their standard operation only when the back angle keeps ± 25 degree to the vertical line, hence, avoid moving with the seats absolutely lied.
- Avoid adjusting seat's angle when the vehicle is moving.

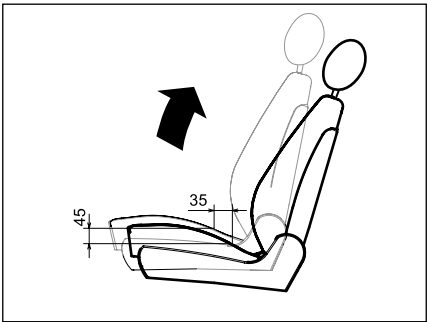

3. Adjusting seat's height angle



Tilt the back side of this key up and down to adjust the seat's height.

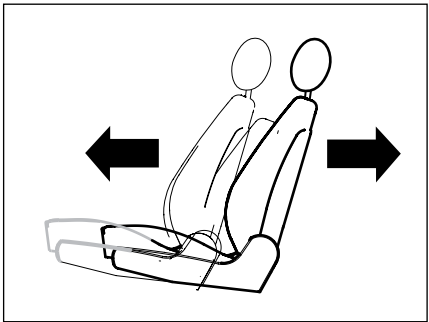

4. Seat's rail adjustment key



Pull the clamp in longitudinal motion to adjust your appropriate position.

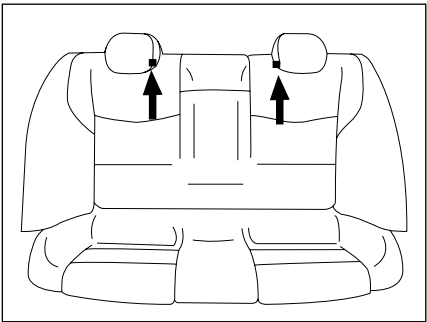

Adjusting back seat headrests height

When the passenger seats on back seats, he or she shall pull up the headrest according to the image.



WARNING

- Make sure that passenger(s) foot is not located beneath the seat when you are trying to adjust seat settings.
- Avoid adjusting seat settings when the vehicle is moving.
- Taking into consideration that the headrest is a safety tool, make sure its appropriate location.

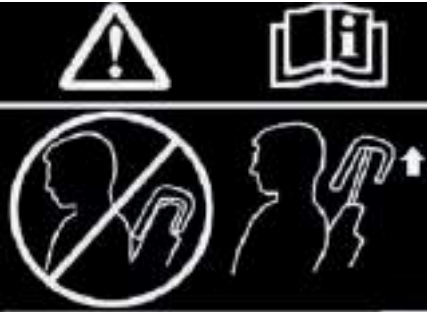

*If your vehicle is equipped

SEATS

2

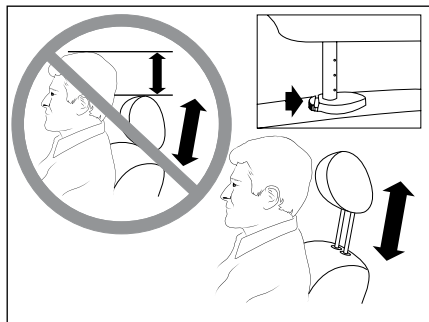

Headrest height adjustment

Pull the headrest upward to adjust it in appropriate angle, you can also pull it down to lower its height, to do so, you shall first press the clamp then try to move it upward or downward.*

NOTICE

Avoid ejecting the headrest completely, unless in emergency cases.

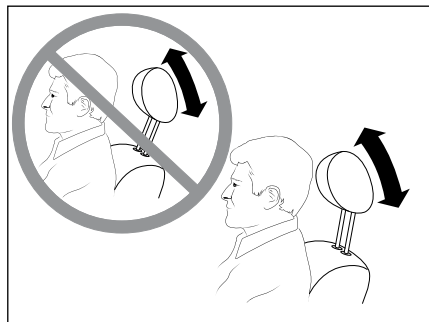

Head position according to the headrest *

The headrest is designed to avoid severe moving of the head backward, so that its appropriate adjustment will help protecting head and neck.

Furthermore, the head rest is able to be opened on front side and closed on back side, you can see its image in the above figure.

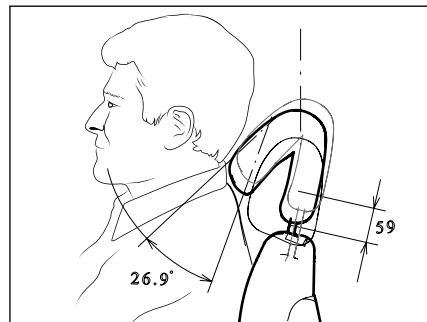

Head position according to the headrest *

The headrest is designed to avoid severe moving of the head backward, so that its appropriate adjustment will help protecting head and neck.

Furthermore the head rest is able to rotate towards the front and back at its position.



CAUTIONS

Taking into consideration that the headrest is designed for safety of head and neck, always make sure its appropriate position in order to decrease the risks of danger to driver and front passengers. Please observe the above considerations in order to adjust and set the headrest appropriately.

*If your vehicle is equipped

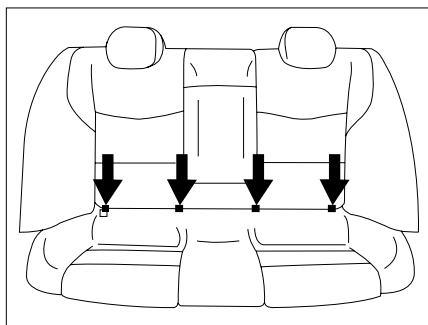

Installing baby seat based on ISOFIX method

Baby seats equipped with isofix system have two locking hooks at the bottom of the chair, which connect easily to two rings located between the back rest and seat floor. It has a belt and a buckle at its end connecting to a ring located on the rear niche.

Isofix seats are easily installed and prevents moving and rotating the child seat as far as possible.

In this vehicle, there are two mounting positions for the seats equipped with isofix .

Both the positions are located on lateral rear seats of the vehicle.

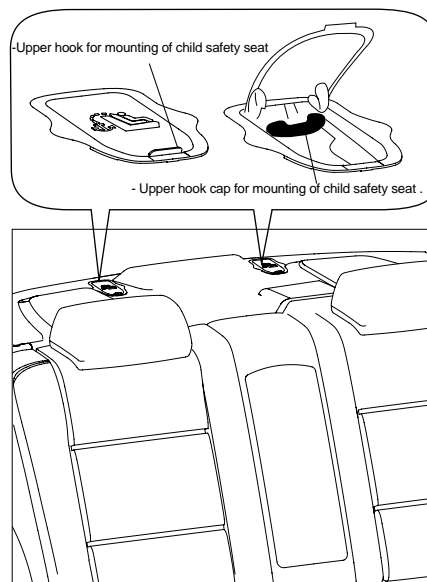

Connectors of the baby seat which is showed on the image include three rings, two of which are designed between the floor and back space and the other one is designed on the back of rear seat.

In order to install the baby seat equipped with ISOFIX, first fix two clamps of board to the clamps of back and floor, and the third above clamp shall be then installed on the niche. Please release the above clamp's cover at first, and then you can fasten it.

CHILDREN SAFETY

2

Installing baby seat's hook belt

Pass the hook belt from seat back whether it is single or dual designed in case no headrest is installed. See the below image.

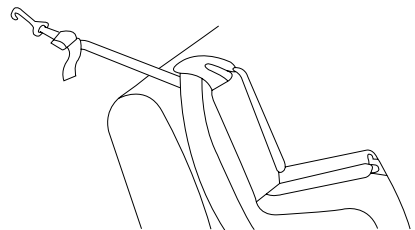
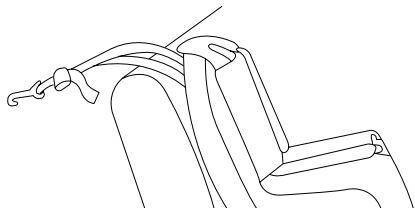

In case the baby seat is installed where the portable headrest exists, you shall pull up the headrest, pass the hook belt under it, then pull it down, or if the hook belt is dual designed, pass it from two sides of the headrest. See the below image.

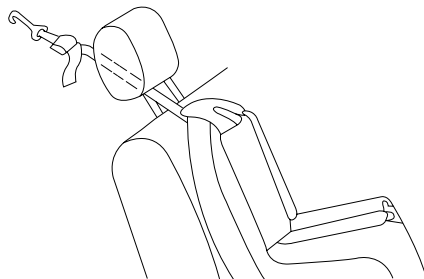
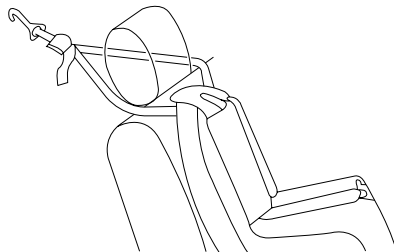

In case the baby seat is installed where the fixed headrest is installed, you shall pass the hook belt from above the headrest in case it is single designed.

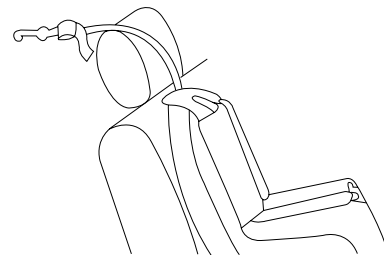

In case the baby seat is installed where the fixed headrest is installed, you shall pass two sides of hook belt from above the headrest in case it is dual designed. See the above image.

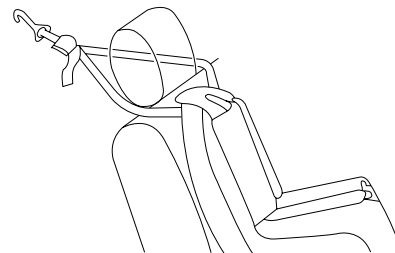

Correct position table for installation of seat child , with capability of fastening with adult seat belts and isofix child seat

Baby seat type	Baby weight	Baby seat size	Position of front passenger seat	Position of rear lateral seats	Position of rear central seat
Transverse cradle of baby – Children's weight category 0	<10kg	F,G	X	U(2)	X
Seat towards the back. Children's weight category 0 & +0	<10kg &<13kg	E	U(1)	U(3)	X
Seat towards the back. Children's weight category +0 & 1	<13kg and 9 to 18 kg	C,D	U(1)	U(3)	X
Seat towards the front. Children's weight category 1	9 to 18 kg	X	X	U-IUF(4)	X
booster Children's weight category 2&3	15 to 25kg 22 to 36kg	X	X	U(4)	X

X= This position is not suitable for installing a child seat

U= This position is suitable for the installation of a universal child seat through an adult seat belt.

IUF=This position is suitable for installing the front face -universal child seat through an isofix hook

CHILDREN SAFETY

2

Description of previous table:

- (1) Adjust the vehicle seat to the most rear and highest position. The seatback angle must be approximately 25 degrees.
- (2) A cradle is installed transversely in the vehicle and occupies two seats of the rear row. Place the cradle in a position where the legs are close to the door.
- (3) Move the front seat towards the front as far as possible in order to install the child seat towards the back in the rear row, and then after installation move it to rear side again so as not to hit the child seat .
- (4) To install the child seat towards the front in rear row, separate the seat head rest of the vehicle first.
- (5) The statistics shows that children in all ages and weights are protected and are more safety when they sit in rear seats.



WARNING

- Never place an object on floor of the vehicle, because when the vehicle brakes, there is a risk of placing the object beneath the pedals which may cause severe dangers.
- Never let the children to seat on your foot because there is a risk of severe dangers. Never fasten a seat belt for more than one passenger.

**WARNING**

- Make sure the appropriate fixture of above hooks to the belt of baby seat located on back niche . Refer to installation manual. Or, appropriate safety may not be provided in case of any accident.
- Pay attention to different types of fastening upper hook based on different positions of the headrest.
- Baby seats endure for the forces inflicted by the children and for the determined amount of forces, not for adults. Actually adults who fix their seat belt to the baby board will cause severe risks and dangers in the accidents because of baby seat overload.
- Never make use of audio systems which cause releasing the upper hooks of the baby seat.
- Accidents may cause damages to the vehicle ISOFIX system, damaged ISOFIX systems will not procure enough safety and will cause severe dangers at the times of accidents. So, ensure the appropriate operation of ISOFIX system as soon as possible, and make sure that the system is operating mechanically true and plan for periodical checkups for this system.

CHILDREN SAFETY

2

People under 7 or 8 years because of difference of the head weight as compared with, body are considered child. In sudden decrease of speed head weight can cause a serious injuries to the spinal column due to the weakness of children neck muscles. Children can bring serious damage to the Only when passengers are 13 years old or their height is 137 cm can be considered teenager.

That is why in most countries certain laws have been predicted for traveling and for the use of safety devices for children.

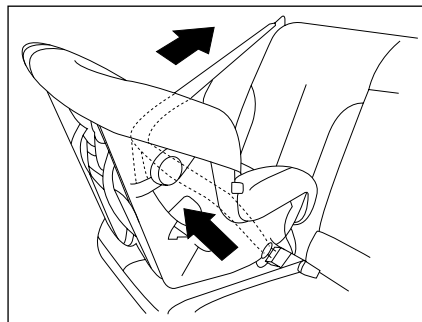

The baby board up to 9 months-old, (up to 10 Kgr), shall be installed in back side from three connection points to the seat belt (belt with locker roll).

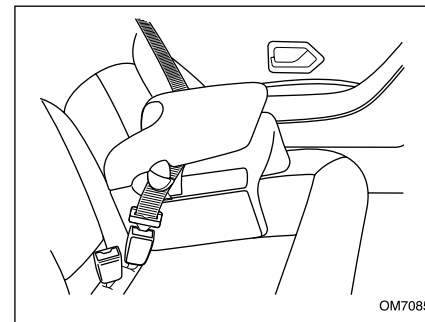

The baby board for 9-months to 3-years, (up to 18 Kgr) shall be installed on front side, at back seat, with 2 or 3 connection points to the seat belt (simple belt or belt with locker roll).



Caution

For safety considerations, the child less than 13 years-old shall seat on back seats.

Never let the children less than 13 years-old to seat on front seat.

Never fix baby seat, installed on front side, on the front seats.



WARNINGS

Never put an object on floor of vehicle, especially on driver's side, because there may move beneath the pedals on brake times and cease pedals operations which may cause severe dangers.

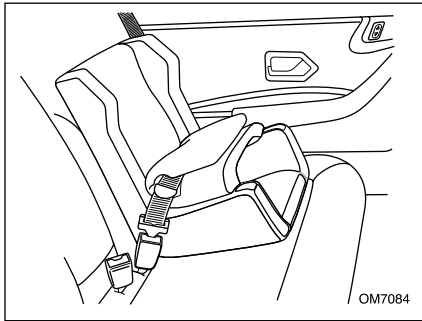

Children more than 3 years old with over 15 Kg weights can seat in back seat with special care in front side in a way that the belt is fasten in two or three points to the protector. (This method is also useful for children between 3 to 6 years old)

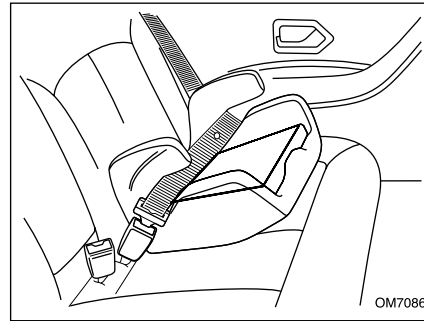

Children with large body older than 3 can seat with an additional mat (seat booster) in back seat in front side in a way that the belt is fasten in 2 or 3 points to the additional mat. This method is useful specially or children between 3 to 6 years old.

**WARNINGS**

Never let and put Infants and children in front seats on your foot, because there is a high risk of severe dangers.
Never fasten a seat belt for more than one person simultaneously.

*If equipped

SAFETY BELT

Safety points for seat belts

The seat belts designed on your vehicle is only for mature persons and each for just one person. Always make sure than all passengers have seat belts and pay attention to the following cautions.

2

- Never let all passengers to bend their seats more than standards level. The seat belts have their best functionality only when the backward or forward angle of passengers with the vertebral line is ± 25 degrees.
- Fix the seat belts in a way that they have no free spaces. Never move the belt far from your body when the vehicle is moving. The seat belts shall always have close contact with the body.
- The lower belt shall not pass the stomach, but it shall pass the pelvic region. The diagonal belt shall pass the shoulder and chest without any force to the neck.
- Get rid of sharp objects like blades, pen, pencil, etc. from your clothes before moving. Pay attention that the seat belts never rotate wrongly which may cause its lack of operation.
- You shall replace the seat belts which are damaged or erode.
- You can make use of back seat belts to make the back objects fixed, so in accidents they will not be thrown towards you.
- In most of the countries, fastening seat belts is a mandatory, except for a few persons with medical limitations.
- The pregnant ladies shall pass the seat belts from their shoulder, between breasts and one side of their stomach, please refer your physician in this regard.
- The seats belts are equipped with pretension systems to pull back the belts and location appropriate position.
- The seat belts are equipped with force limiter system in order to control the inflicted force to the chest of passengers at accidents.

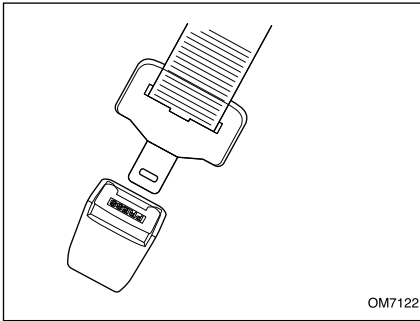

OM7122

Fastening seat belts

Pass the seat belts slowly from the shoulder and chest and make sure that they are not rotated. Then fasten its metal hook to the special hole and hear the click sound to ensure its locking.



Caution

The seat belts have their appropriate functionality only when the seats are vertical. Never let the front passengers to bend their seats more than standard angle. Doing so will cause to the warning light of belts to be turned on.

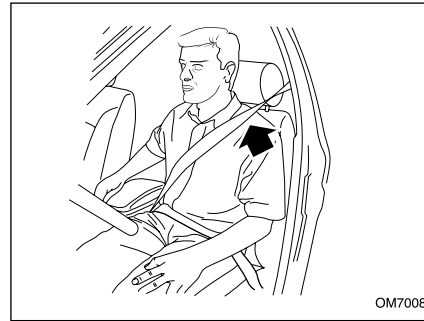

OM7008



Caution

- Never let adhesive materials to penetrate on seat belt locker hole because it may loss it's functioning.
- Always keep the front seat belts as closed so as to help the air bags function at their best.
- Never let infants and/or children to seat down on your foots in front seats, because it may cause severe risks of damages. Never fasten a seat belt for more than one person.

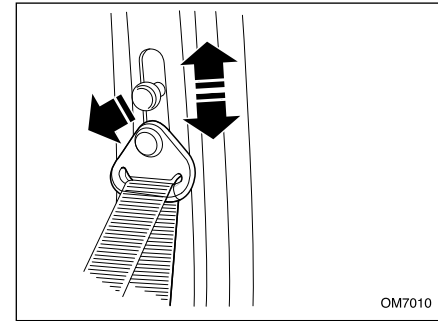

OM7010

Adjusting the height of front seat belts

To adjust its height, pull out the height adjusting key or move it upward or downward. From safety points of view, it's always better to put the children on back seats.



Caution

In order to ensure the appropriate functioning of seat belts, always make sure that the belts are passing your shoulder and make sure on appropriate angle of seats and its back.

PRETENSION SEAT BELT

2

Force pretension and limiter

On crashes from the front side, the safety of front seats were improved brilliantly because of existing pretension and force limiter systems in the seat belts. The pretension system will operate more severely in proportion of level of accidents and pull it more strongly to the side of seat and driver.

1. The initial traction system will be activated with the switch ON.

2. Seat belt's force limiters:

This mechanism will reduce the force inflicted on the passenger's seat at crashes and accidents.

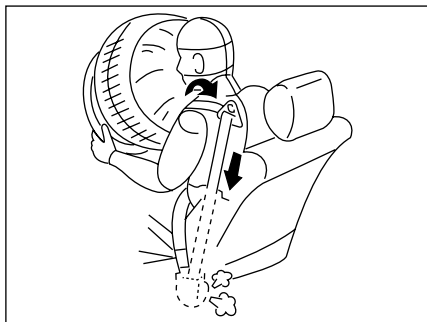

Pretension seat belt

The seat belts with the mechanism of air bags will be only activating on severe accidents from front side. Actually, they are not designed for crashes from back, side, overturning or light accidents, so that they will not be activated in such cases. The pretension system of seat belts will operate just once, in case it operates, you shall refer authorized Iran Khodro Office to replace them.



WARNING

Service and maintenance of seat belts pretension system and the related wiring system shall be only done by the experts of Iran Khodro Co.

Careless modifications or repair may cause their malfunctioning which may cause severe dangers.

The seat belts have their appropriate functionality only when they are tightly fastened on body. The pretension system of seat belts will operate simultaneously with the air bags in proportionate to the level and type of accidents.

In case of malfunctioning in one of the abovementioned items or error in the system, the warning light of air bags will turn on which you can see in vehicle's digital display.

Standard fire extinguishers

Dear users shall study its user's manual before using.

Product characteristics

1. This type of capsule is filled with dry chemical powder with 16 gr of Co2 under pressure.

After pulling the clamp, the gas will be mixed up with the dry chemical powder and will cause releasing of chemical materials.

2. The maintenance degree centigrade in Iran is between -30 to 90 degrees centigrade.

3. Having special cartridge, this capsule will not need periodical monitoring up to 5 years. The capsule will be easily charges in case of its termination.

4. Never hunk of powder in case of vibrations arising from severe crashes and enduring temperature are deemed as some of its characteristics.

Application

The activation method is written in Persian on the body of extinguisher which shall be studies exactly.

- Pull the clamp
- Pull the upper door's clamp upwards.
- Hold the sprayer in central direction of the fire and push the handle down to release chemical materials.

Notice

In case of firing in engine compartment, never open the compartment completely so as to avoid reaching air there. After pulling the extinguisher's clamp, open up the engine compartment for 10 to 15 cm, and release the chemical materials slowly there for 1 to 2 minutes, then open it up completely and continue releasing. Pay attention that the capacity of this capsule is one Kgr and its release time is 7 to 10 seconds. Hence, take care not to waste the material.

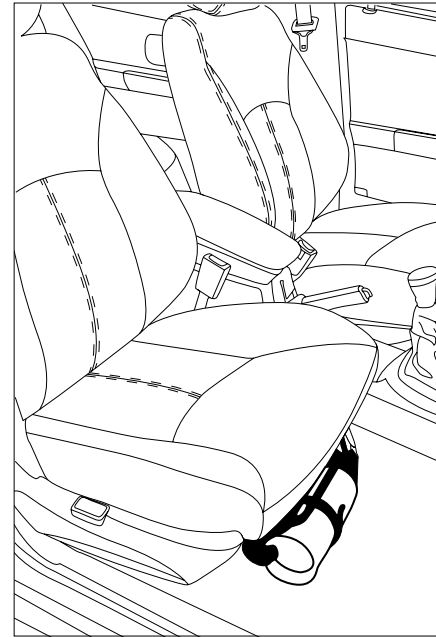
**CAUTION**

The basic condition of using the fire extinguishers is skill and patience. The company will not borne any responsibility in respect of negligent using of the fire extinguishers

FIRE EXTINGUISHER

2

Necessary tips

1. Never open the drainage valve of the fire extinguisher heedlessly, because this will cause malfunctions at necessary emergency times.
2. At firing or emergency situations, in case of locking doors or windows, you can make use of capsule to crash the windows, then get out of the vehicle to eliminate the fire.
3. Although the capsule materials are not toxic, but never contact them with your eyes and face.
4. Make sure that the capsule is located in appropriate place in the vehicle and its plastic hook is locked appropriately.

This is to be mentioned that in other case, there will be a risk of releasing capsule at accidents which may cause severe dangers.

5. Keep patience at firing and do the fire fighting steps carefully.
6. It is worth mentioning that the present fire extinguisher is designed to eliminate fire at its initial steps, in case of blazing and big fires, instantly call the emergency forces to take action for eliminating fire.



WARNING

Skill and patience at the time of using fire extinguishers are deemed as integral conditions and the automotive company will not bear any responsibility in case of careless using of fire extinguishers.

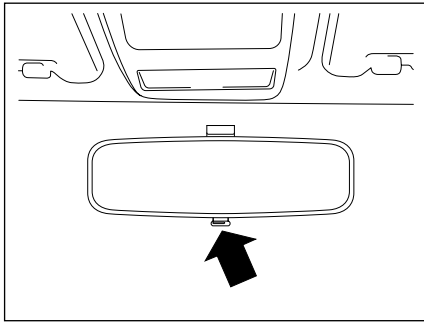

Adjusting electric mirrors

1. After opening the ignition switch, select the mirror to be adjusted in left or right direction by turning the key.
2. Moving the adjustment key in four directions will adjust the electric mirrors accordingly in those four sides.



CAUTION

The objects image in the mirror seems far than their real distance.

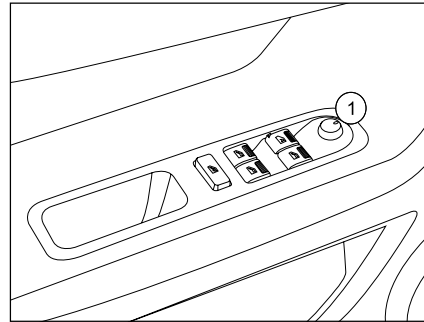

Front mirror

After adjusting the seat and steering wheel, you can adjust the front mirror for night mode to get rid of headlights of vehicles on opposite direction by pressing the night mode key of the mirror, or vice versa.

Note:

Adjusting the front mirror in night mode will decrease the vision of rear vehicles, and sometimes the lack of enough vision may bring some dangers because lack of appropriate diagnosis of rear vehicles position.

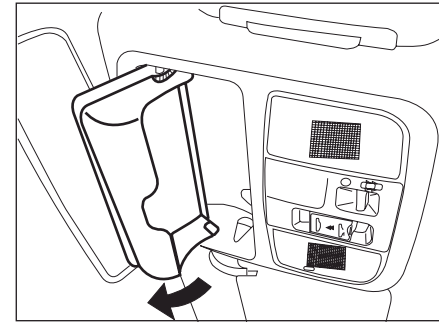

A PLACE FOR KEEPING GLASSES *

Glasses location will be opened by upward pushing of vent and leaving it. Then you can keep your glasses in it.

*If installed on your vehicle

MIRRORS

2

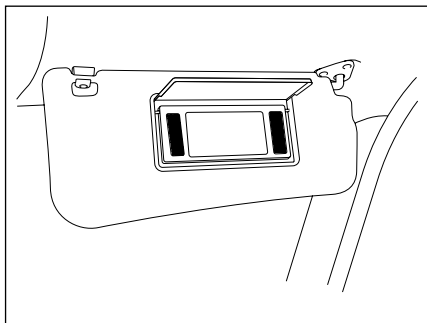

Make-up mirror

Pull down the sun visor to make use of the make-up mirror.



WARNING

Never bend the electric mirror by hand in order to prevent damages to its electrical motor.

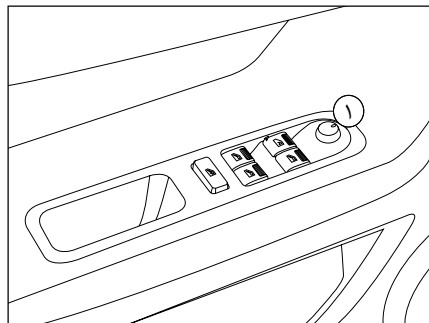

Folding electric mirror

Most of drivers are informed of advantages of folding electric mirrors especially when the vehicle is parked in busy places. Some of its advantages are more safety for mirrors especially when it is parked in small spaces. To fold the mirrors, it is enough to rotate the key 1 to 180 degree and push it down.

To unfold the mirrors, you shall push it up. This is to be mentioned that the electric mirrors will fold automatically by powering the engine off and closing the vehicle doors, then will be opened by opening doors with the remote control.

Pressing the “lock” button on remote control for one time will lock all doors, and the next pressing will fold the mirrors. (in a time less than 10 seconds)

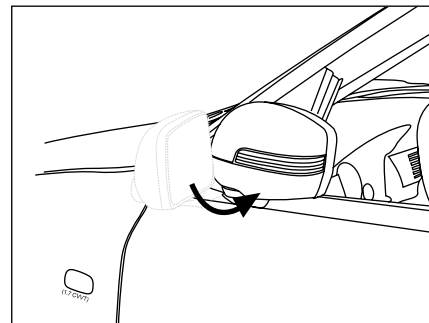

Pressing the “unlock” button on remote control for one time will unlock all doors, and the next pressing will unlock the mirrors.



Note

In some models the mirrors are opened or closed alternatively by 90 degree rotating of key no 1 clockwise or anti-clockwise.



WARNING

please don't adjust the mirrors while you're driving .it's very dangerous.

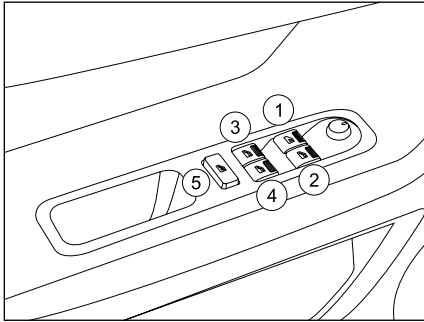

Side Glasses

Adjustment keys in driver's side:

1. Front glass on left side
2. Front glass on right side
3. Back glass on left side
4. Back glass on right side

The Driver is able to lock all back glasses.

Locking key of back windows

5. When the driver presses this key, all back windows keys will be inactivated. This mechanism is also designed to protect children against risks.

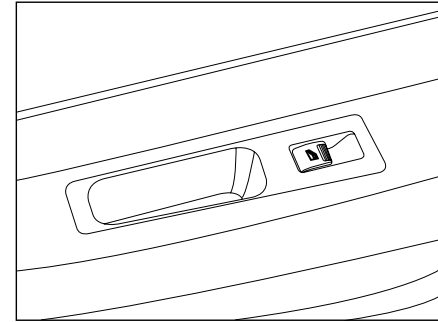

Windows key

Each passenger is able to regulate and adjust his/her own side windows by the related designed keys.

Back windows keys will not function if the driver pressed the back windows lock key.



NOTICE

Never leave your vehicle when a child (or a pet), or key card is remained in the vehicle. Actually,. The children or pet are able to activate the electric windows and cause damages to their body which may result is severe injuries. In this case, immediately open the windows to eliminate the issue.



WARNING

Remaining some parts of body including hands, head, and fingers on the way of electric mirrors may cause severe injuries.

Closing the windows inappropriately may cause severe injuries and/or damages.

GLASS LIFTER

2

Smart windows lifters *

The modern smart windows lifters designed on your vehicle includes an electrical circuit with the following functions:

1. Safety anti-pinch system;
2. Automatic windows closing after leaving the vehicle;
3. Lift up / down command of four doors windows; and
4. Slow opening windows at the end of route.



Caution

The Anti-pinch system designed in this vehicle prevents damages against severe obstacles, so careful action in this regard is always advised.

Anti-Pinch safety system *

This is a safety system to prevent locating parts of your body or objects between the windows when the windows is lifting up. Having been equipped with this mechanism, the windows will come back down if they impact with any object and result in more safety in this regard. Furthermore, this mechanism causes useful time prolongation of vehicle's windows.

Automatic lifting up of windows*

This mechanism helps the driver to checkup the windows one by one when he or she left the vehicle, and lift them up if they are not.

Pressing key 1 on remote control for one time will lock all doors, and the next pressing of the same key will lift up the windows.



WARNING

Make sure the automatic closing of all windows before completely leaving the vehicle at park.

This safety system will eliminate the risks of careless leaving of vehicles and will cause the driver to be relaxed if he or she is not sure of closing the windows.

Lift up/down command of four windows*

This mechanism enables the person to lift up or open the windows of four doors simultaneously in both automatic and manual methods.

In ordinary designs, just drivers windows have this capability.

Manual mode

Press the windows key up and release it, the windows will stop when you released the key.

Automatic mode

Shortly press the key and enjoy its automatic move.

This mechanism enables the person to lift up or open the windows of four doors simultaneously in both automatic and manual methods.

Shortly pressing will do it automatically and holding the key will do it manually for both up and down directions.

Pressing and holding key will stop the movement at the moment you released the key for both up and down directions. Shortly pressing of the key will make it automatically up to its complete movement.

*If installed on your vehicle

Slow stop of windows at the end of route *

In this mechanism, the windows speed at the end of route will become slow and slow and will stop without inflicting any damage to the doors.

This mechanism omits the sound of this task and will increase the useful life of internal components.

Needless to say that the anti-pinch system is active in both manual and automatic mode and the windows move will be cancelled if there is an object on the way, and the windows will move on contrary way.

Reminder

The Anti-Pinch system is not activated at the time of setting up the system.

Reminder

The smart windows lifter is equipped with a sensor which registers the position of windows in each moment, and this is to diagnose the start and end range of the windows movement. The initial settings are set in the automotive plant. For any reason including dismantling the battery or if in case of cutting off the initial power of windows lifter, the initial settings will be deleted and new capacities of smart windows lifters will be omitted.

You shall do the initial settings once against after connecting the battery resource. Follow the easy three steps below to do this:

1. Move the windows completely up to the end.
2. Move the windows completely up by manual mode of lifting (note that the automatic mode is not activated now) .
3. Press and hold the key for 1 second after the windows was reached to the end completely.

*If installed on your vehicle

INTERNAL LAMPS

2

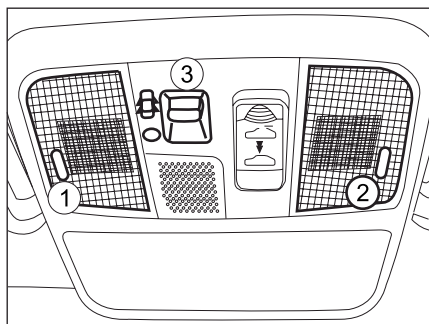

Front roof light

1. Front light of Drier.
2. Front light of passenger.
- 3- It gets on by opening either front / rear doors or booth.
- 4- The lights are off

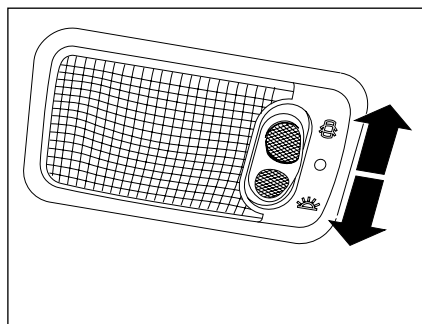

Back roof light

This light will be turned off by opening each of doors. It will be turned off after 12 seconds if the ignition switch is OFF.

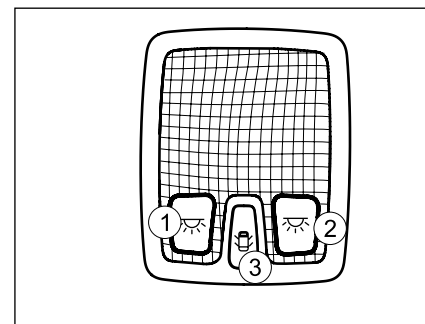

Front roof light

1. Front light of Drier
2. Front light of passenger
3. The light which will be turned on after opening a door. It will be turned off after 12 seconds if the ignition switch is OFF.



One of doors is open : Light on

Light off

Light on

*If installed on your vehicle

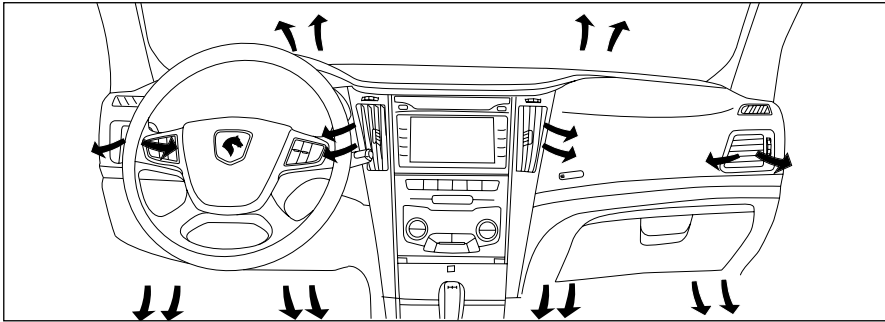

Heating and ventilation

The heating and ventilation system of vehicles will direct the fresh air or warm air from inlets designed in different parts of the vehicle.

The vents are designed for the windshield, face and foot for front passengers.

Also there are vents for back passengers at the end of central box.

The detailed description of heating system and air vent settings are discussed in next page.

Necessary tip:

Never cover the back niche on the vent canal in order to help complete air circulation in and out of the vehicles.



WRNING

Avoid turning on the cooling fluid circuit, this is harmful for eyes and skin.

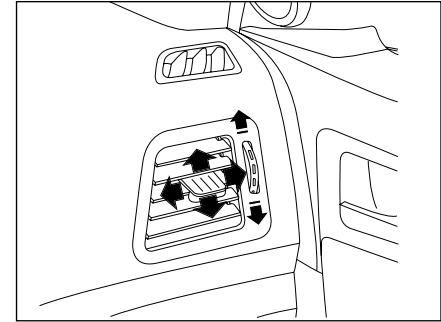

Air vents

In case you rotate the key down and up, the air vent will be closed/opened.

By moving the central key to side directions or up and down, will regulate the air circulation.



WARNING

- Make use of distilled water in the radiator, in order to avoid fouling of heater.
- Turn on your cooler every 15 days for 10 minutes even in the semester.
- To turn off the cooler, first turn off the A/C button, then turn off the engine after seconds.
- Charging the cooler gas with a gas other than R-134a will inflict damages on you ventilation system.
- Make use of R-134a gas which is compatible with the environment and non-destructive to ozone layer in your vehicles air vent system.

HEATING AND VENTILATION

Automatic air vent

1. Turning vents system ON and OFF
2. Adjusting fan speed up/down
3. Turning on windshield heater
4. Automatic adjustment of vent system
5. Selection of air circulation direction
6. Control air entrance
7. Turning on back windows heater
8. Adjusting temperature up/down
9. Turning on the cooler

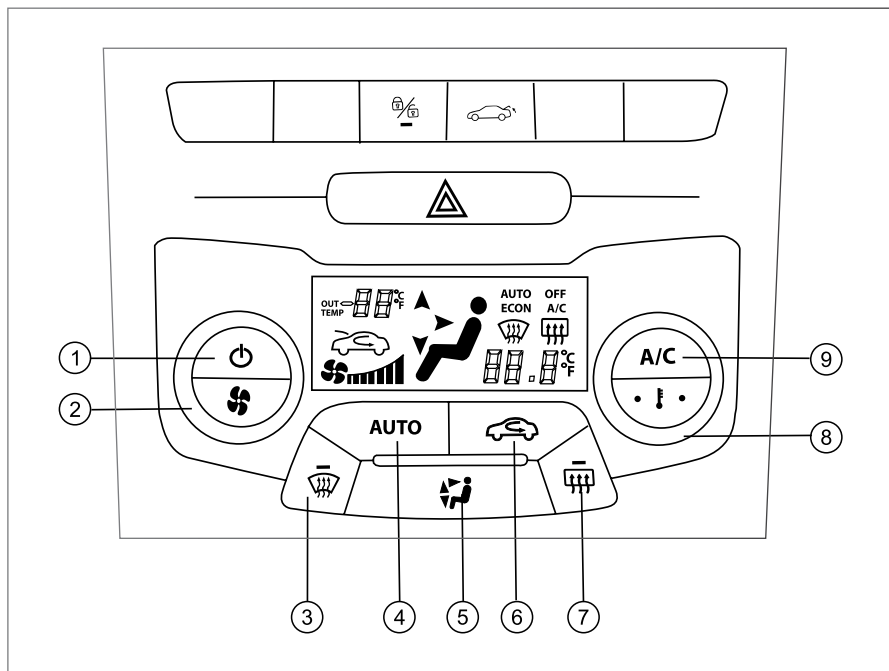

1-2. Fan speed adjustment key

- Automatic system of vehicle will be turned ON/OFF by turning this volume.
- Fan speed will increase/decrease by turning this volume to right and left.
- In automatic mode, the fan speed will be adjusted based on determined temperature.

3. Windshield heater





Press this button In order to eliminate fog or freezing of windshield. By pressing this button, the cooler will be turned on and fan speed and temperature will be automatically adjusted to maximum with windshield air vents open. Vapors and frosts will be eliminated and cleaned from the windshield automatically.

4. AUTO key

By pressing this key, the vent system will automatically adjust and the settings to reach the predetermined temperature. All functions including fan speed, vent canals will be set automatically in this mode. Turn volume No. 9 to determine your favorite temperature. The determined temperature will be shown on display. It is advised that you enjoy this auto mechanism because there will be no need to adjust the settings manually in this mode.

5. Air direction selection key

You can change the air direction by pressing this key consecutively.

- Face 
- Face and foot 
- Foot 
- Foot and windshield 
- Windshield 

The air direction will be shown on display, in case of pressing AUTO key, this operation will be set automatically. By pressing air direction selection key, the air vent system will exit from AUTO mode.

6. Air inlet control key

By pressing this key, you are able to stop air exchanging and just the internal vehicle's air will be circulated within the vehicle. Avoid using this mode for a long time because lack of fresh air, by pressing this key again, the air exchanging will be again started. Air inlet circulation also operates even if the air vent is off. OFF will be shown on display when the air vent is off, by pressing the air vent keys, this light will disappear.

7. Back windows heater key



You can turn on back windows heater by pressing this key, the system will be then turned on for 10 minutes. You can press this key again before such 12 minutes is terminated. this mechanism can also operate even if the air vent sys is OFF.

8. Temperature selection volume

You can adjust the internal temperature by turning this volume. Turning the volume to rights (H) will increase the temperature and turning to left (C) will decrease.

This temperature can be adjusted within the range of 14 to 32 degree.

By selecting the temperature 14, the system will function with its Max. capacity of frigorific and by selecting the temperature 32 , the system will function with its Max . capacity of calorific and by selecting the temperature 15 to 31, the system controls the temperature automatically.

This volume will not function when the air vent sys is OFF. You can turn of the air vent sys by pressing OFF button. Pressing nay keys of AUTO, A/C, fan speed control key  and front/back windshield heaters  /  will turn on the air vent system.

HEATING AND VENTILATION

2

9. A/C Button

This Key is to turn on/off the vehicle's cooler system.

The word "ECO" will be displayed on screen when the cooler is off, by turning on this system the word "A/C" will be shown on screen. The setting will be started according to the latest configuration.

Caution

- 1.The fan of vent system will not function for 3 minutes at winters when the outdoor and engine's temperature is highly low, until it reaches to an appropriate temperature.
- 2.The auto air vent system is designed to control the entrance of polluted air, dust, and smoke in the vehicle's air filter you shall replace the air filter according to the timetable of user's manual.
- 3.You shall replace the air filter in case of malfunctioning including weak fan speed or any odor.
- 4.Make use of anti-freezing liquid in order to avoid fouling of heater.
- 5.To turn off the air vent system, first press the OFF button then turns off the engine.
- 6.Cooler gas shall be only charges with R134 gas.
- 7.Never block the air input channels on the tail of windshield.
- 8.Never put objects on light sensor of dashboard, and temperature sensor of front bumper.
- 9.It is advised to make use of AUTO air vent mechanism, because in this way the operation of temperature adjustment will be done by means of several sensors designed within and there will be no need for several pressing of different keys.



WARNING

- 1.Air vent system will function when the engine is power on.
- 2.Never leave disabled and children passengers alone in the vehicle.
- 3.The internal air temperature will be highly increased on hot summer days with the risk of severe dangers.
- 4.Avoid using internal air circulation mode because of lack of oxygen in the vehicle.
- 5.Favorite temperature is adjustable according to the passengers taste (recommended summer temperature is 22 degree and winter is 26 degree)
- 6.When the vehicle is parked at a hot place with direct sunlight, first open the windows for a while to get rid of internal hot air, then try to turn on the cooler system.
- 7.Turn on the air vent system twice a month for 5 to 10 minutes in order for good maintenance.



Caution

Never open the cooler fluid circuit because this is severely dangerous for eyes and face. Refer to authorized branch office in case of any problem.

**WARNING**

- In cases where the car has an air conditioning system, note that sunlight sensors and temperature sensors inside the cabin will not be blocked because blockage of these sensors can lead to inappropriate performance of the ventilation system.*
- When you're driving uphill, it is necessary to turn off the air conditioning system in order to prevent excessive pressure on the engine.
- The presence of snow, ice, etc. in the way of entering the air into the cabin will cause improper performance of the air conditioning system of the . Therefore, in order to ventilate the interior of the cabin, ensure that the intake air is not obstructed into the cabin.
- Permanent use of the air conditioning system during air circulation in winter or during rain can cause windshield fogging and obstruction of the driver's vision and the accident. So, in this situation, use the fresh air intake mode to the cabin.
- In order to ensure the correct operation of the vehicle air conditioning system, checking the Air conditioning pipes are essential to ensure the lack of leakage.

In wet climates, the formation of steam on the glass is a natural occurrence. Therefore, turn on the vehicle air conditioning system, to get inside of the vehicle air dehumidified. In warm seasons and when the vehicle is exposed to sunlight for a long time, first open the glass and let the warm air get out of the vehicle and then turn on the air conditioning system.

This is caused to reduce fuel consumption and improves air quality of the cabin.

**WARNING**

- Avoid sleeping in the vehicle when the air conditioning system (cooler or heater) is on, as , this may result in increase in carbon dioxide in the cabin or an increase in body temperature causing serious injury and even death.
- Long-term use of the air conditioning system in air circulation condition can cause the reduction of the air inside the vehicle and cause the passengers to feel sleepy that can result in an accident.

INTERNAL EQUIPMENT

2

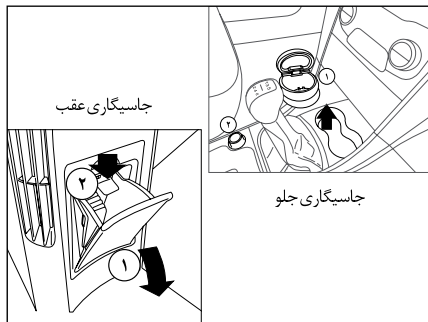

Front ashtray

The ashtray is designed on the tail of front box.

1. This ashtray is removable like a glass to vacate it.
2. Lighter

Back ashtray

1. This is designed on the door and one can pull it down to open it.
2. Push the clamp down to remove it and vacate the ashes.

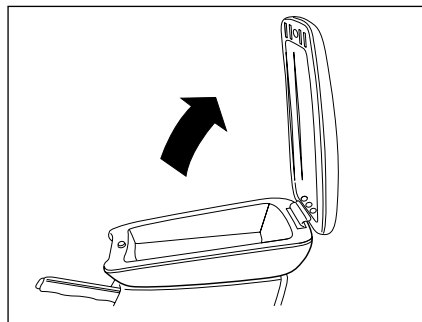

جعبه کنسول جلو

- جعبه کنسول پایین زیر آرنجی مرکزی قرار دارد.
- برای باز کردن، فشاری به گیره زیر درپوش وارد کنید تا درپوش آزاد شود و سپس آن را باز کنید.
- کفیپوشی در جعبه تعبیه شده که در صورت کثیف شدن می توان آن را برداشت و دوباره در جای خود قرار داد.



Caution

The ashtrays are deemed dangerous in respect of firing risks, hence never put papers or flammable objects in.

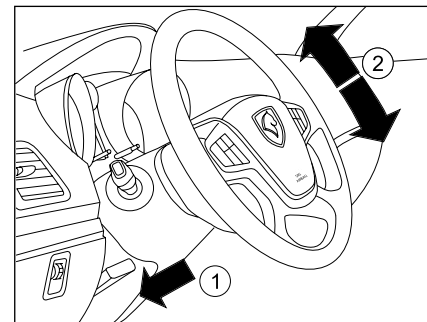

Adjusting the angle of steering wheel

You shall adjust the angle of steering wheel based on your body position. First you shall adjust your seat angle, and make sure that all dashboard and display lights are within your vision clearly, and then try to adjust the angle of steering wheel.

1. Pull down the adjustment lever to release its lock.
2. Try to adjust the angle of steering wheel and then pull up the lever to lock the steering wheel in this position.



Caution

Never try to adjust the angle of steering wheel when the vehicle is moving because this is severely dangerous. Hence, do it at stop.

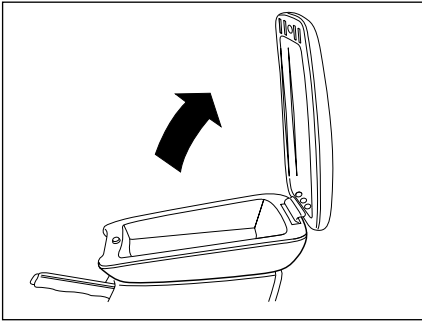
**Front console box**

- The console box is designed beneath the front elbow.
- Pull its door up to open it.
- You shall push the clamp to open it up.
- There is flooring on the console box which is removable to be cleaned.

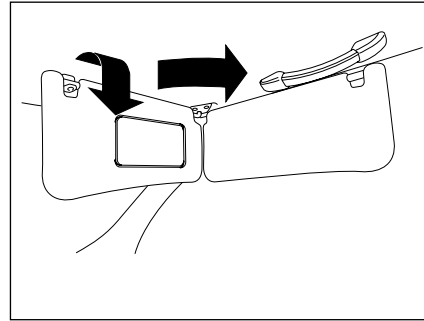
**Sun visor**

- You can pull it down to protect your eyes and skin from direct sunlight.
- You can make use it for the windshield and side windows.

INTERNAL EQUIPMENT

2

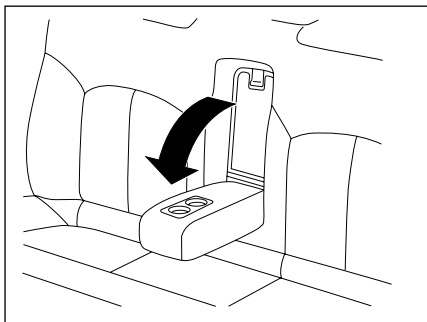

Back elbow

You can pull out the elbow from the back seats. This is for more convenience of back passengers. You shall also pull it out when you want to access the boot.

There are two glass places designed as you see in the image.

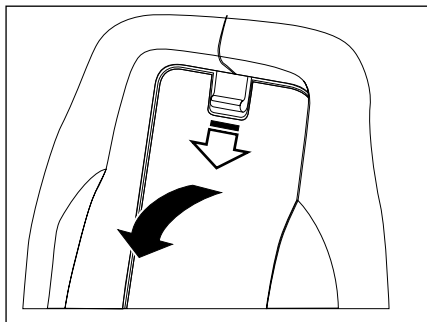

Access gate of boot

- This gate is design behind the back elbow.
- You can make use of it to transfer long object like ski wood, which shall be located in the boot and some part in the vehicle, or have an access to the boot when the vehicle is moving.
- You can pull down its clamp to be located on the elbow, and then you will have access to the boot.

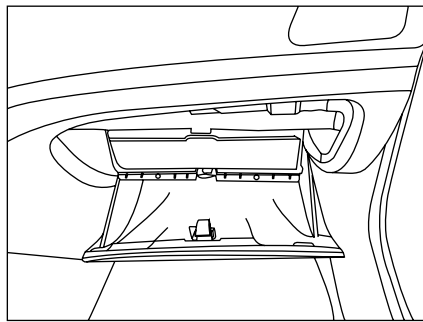

Dashboard box

- Pull down its clamp to open it.
- A light will be turned on the dashboard by its opening, which will be turned off by its closing.

Note: Vehicle's user manual shall be always placed in this box.



CAUTION

Transfer long objects always with special care.

1-BOOT OPENER KEY

To open the boot from inside the vehicle, press the related key for 1.5 seconds, then the boot will be opened.

2. FLASHER

Press the flasher key, all indicators and indicator lights will be turned on flashing. Make use of these lights in emergency only when for example your vehicle is in the way of other vehicles or its emergency cases. These flashers will be remained on even when the engine is off, hence turn off them after eliminating emergency case.

**CAUTION**

Set the clock only when at stop for safety considerations.

3. CENTRAL LOCK KEY

Each press of this key will lock or unlock all doors simultaneously and the related indicator will be shown on the screen.

AUTOMATIC CENTRAL LOCK

At the time of driving at speed higher than 10 Km/h, the doors will be locked automatically. You can shortly press key 3 to unlock the doors temporary.

ACTIVATION

When the ignition switch is on, press and hold the key No.3 for 5 seconds, and then the operation will be activated with the indicator light on the screen.

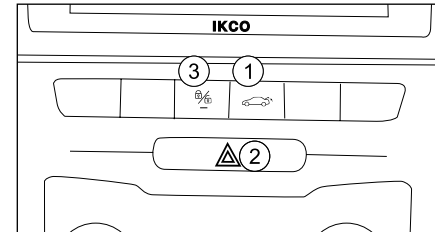
**WARNING**





- In case of electricity cut off, including cases of battery shortage and electrical power supply system, the clock numbers will disappear and the clock shall be set again.
- It's possible to lock or unlock the doors by remote controller and even central key lock after disconnection of battery.
- In order for protection of back windows heater elements, never scratch them or put any adhesive on them.
- The flashers will be automatically turned on in case of any sudden decrease of speed.
- Back windows heater and windows lifters will not function simultaneously.

STEERING WHEEL

AUTOMATIC SAVING OF THE RADIO STATIONS

Audio system panel keys installed on steering wheel*



2

1.  This is for mute operation; pressing again will exit mute operation.
2.  This is for increasing/decreasing the volume.
3.  A) selecting next/previous track (CD/USB)
B) Automatic search of radio stations.
4.  To enter RADIO > CD
PLAYER > USB > AUX > BT
5.  Answer coming calls (in case of receiving call)

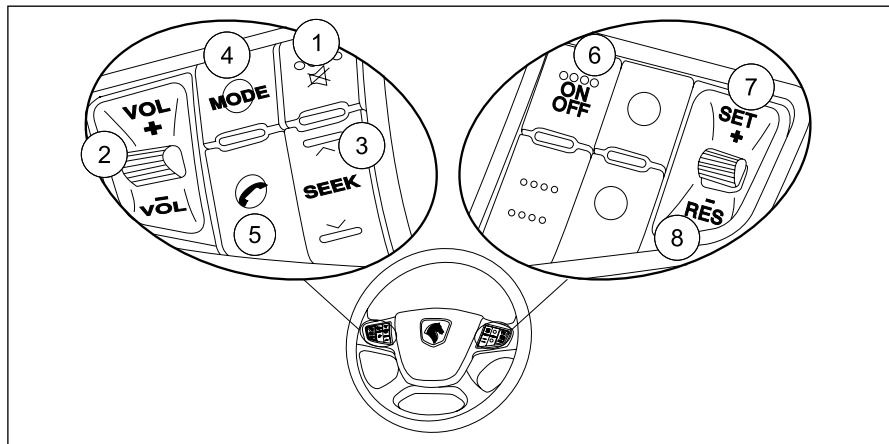
Note: Background light is white, which will be turned on by pressing SLIDE LAMP button.



CRUISE CONTROL KEY INSTALLED ON STEERING WHEEL

6.  Power on/off cruise control
7.  each pressing will cause speed increase for 1 km/h

Pressing and holding this key will increase The speed for 3 km/h. the speed will remain as fixed by releasing this key.

8.  (in case of system inactivation), the system will be activated by pressing and holding this key and he vehicle will run with the previous determined speed. In case no speed is stored in the memory, the vehicle will move with the current speed.

(in case of system activation), pressing and holding this key will decrease the vehicle's speed for 3 km/h and will remain on its speed by releasing the key.

(in case of system activation), each pressing of this key will decrease the vehicle's speed for about 1 km/h.

ROOF LIGHT TIMER (RLT)

The roof light will be controlled by the smart system and will be turned on if:

- 1.The engine is off, one door opens, including boot and hood, and will be turned off after 12 second if the related door closes, meanwhile, if the ignition switch opens, the light will be turned off slowly.
- 2.In case the vehicle is on alarm system, pressing the unlock key of remote control will turn on the roof light, if before auto lock timer, one door opens, this will operate like above paragraph, Or, the auto lock will function and the roof light will disappear.
- 3.This will turn on at accidents and remains until turning ignition switch to OFF.
- 4.In case one door is open when the vehicle is moving, including boot and hood, the roof light will inform the driver by flashing.

AUTOMOBILE FINDER

Pressing the lock key on remote control will help you finding your vehicle by flashing for 15 times when you are searching for the vehicle at a parking.

NOTE:

One flash will takes 500 ms.

DRIVER'S COMPANIONSHIP IN DARK AREAS:

When you want to leave your vehicle in a dark place, this mechanism helps you to light up the area for 30 seconds, so your will be able to pass through the dark area.

For this operation:

- Turn off the lights; first
- Turn the switch to off position first.
- Pull the indicator lever towards yourself within 1 minute;
- Get out of the vehicle and lock the doors.

Then dipped head lamps and side lamps will be turned on and then again will be turned off after 30 seconds automatically.

ALARM SYSTEM

2

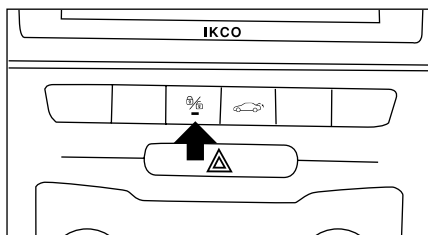

ACTIVATING ALARM SYSTEM

The alarm system will be activated by pressing the lock key on remote control providing that the ignition switch is on its initial mode and all doors are closed appropriately. One flash of indicator lights will inform the driver of activating alarm system.

When the alarm system is on, one LED on small box on the dashboard will flash.

The horn system will horn in case of any following events/:

- Opening any door
- Opening the locks of front doors with an unknown key
- Changing the mode of ignition switch

The alarm system will sound for 30 minutes, and then will be stopped for 5 seconds, in case of risk elimination, flash lights and horn will turn off, or, the previous status will be continued again.

This alarm status will be repeated for 10 times, then the indicator lights and horn will turn off, but the alarm system will still remain activated.

INACTIVATION ALARM SYSTEM

When the horn system is activated, press the "unlock" button on remote control then all doors will be opened and the alarm system will be inactivated. Two indicators flashing will inform the driver of inactivating the alarm system.

We can Inactivate the anti theft alarm by the ignition switch (and not necessarily by remote controller) while we're locking the doors.

This approach is suitable specially when the vehicle is parked in a safe place for a long period of time and there is worries of unnecessary hearing the noise of alarm (Horn sound).

DOORS AUTO-LOCK

In case the doors lock is opened heedlessly by the remote control and no door opens for a while, the doors will be locked again automatically by this mechanism. This mechanism is actually designed to avoid unintentional opening by the remote control. When the speed exceeds 10 km/h, the doors will be locked automatically.

Activating and inactivating this mechanism is accessible by holding the central lock key for 5 seconds.

When the vehicle's speed exceeds 10 km/h in this mode, the doors will be automatically locked. (If the related configuration is activated)

Reminder:

In case of malfunctioning any keys including those of side doors, hood or boot, the related entrance will not be checked up. Such situation will be notified to the driver by 4 time flashing of indicator lamps when the doors are locked by the remote control.

You shall take action to eliminate this issue as soon as possible by referring to an authorized branch office.

In this mode the side doors are locked, if the boot or engine cap is open. But the anti-theft is not activated in this case. All doors are locked ,if one of the side doors are open;but they'll get reopened.

3 DRIVING

DIGITAL FRONT SCREEN LIGHTS	68-70	FUEL SYSTEM	84-85
ALARM LIGHTS	71-73	LIGHTS AND INDICATORS	86-87
DIGITAL SCREEN GUIDE	74-76	HEADLIGHTS HEIGHT ADJUSTMENT	87
AUDIO ALARM LIGHT	77	SNOW WIPERS AND GLASS WASHER	88
CRUISE CONTROL *	78-79	TURBOCHARGER	89-90
STARTING AND DRIVING	80-81	TURBOCHARGER MAINTANENCE	91
FUEL CONSUMPTION DECREASE AND ENVIRONMENTAL PROTECTION	82	BRAKES	92-93
MANUAL GEAR BOX	83	ABS BRAKE SYSTEM	93-94
BACK OBSTACLES ALARM SYSTEM	83	AIR BAG	95-98

*If equipped

THE FRONT PANEL INDICATORS DISPLAY

Indicators and symbols

Warning lights and indexes

1. Fuel shortage warning light
2. Fuel rate light
3. Immobilizer light
4. Speedometer
5. EBD-ABS
6. High beam of head lights
7. Automatic flaw diagnosis light
8. Cooling system fluid temperature light
9. Front fog lights
10. Low beam of head lights
11. RPM light
12. Cruise control on indicator light *
13. Cruise control activation indicator light*

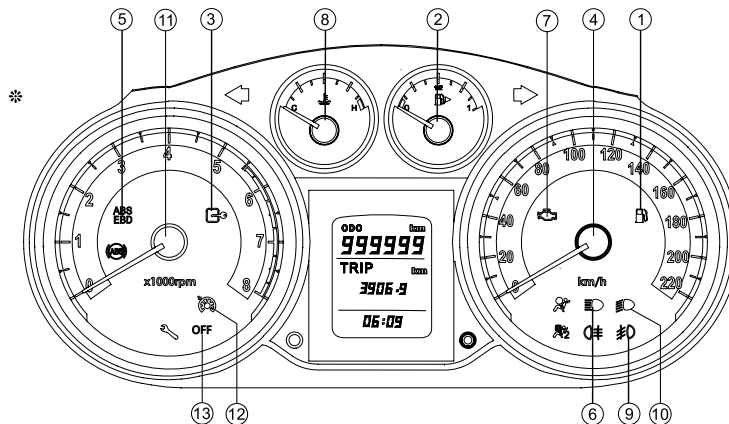
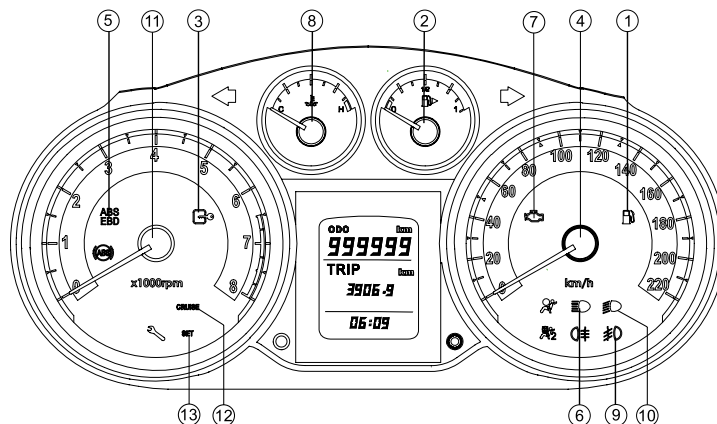

*If installed on your vehicle

THE FRONT PANEL INDICATORS DISPLAY

Indicators and symbols

Warning lights and indexes

1. Front passenger's air bag inactivation light
2. Driver's air bag flaw light
3. Right indicator
4. Left indicator
5. Engine's fuel direction light
6. Back fog light
7. Status modifier and Zero maker
8. Rotating key of front display's lights
9. Periodical service warning light
10. ABS brake indicator light
11. Digital display screen

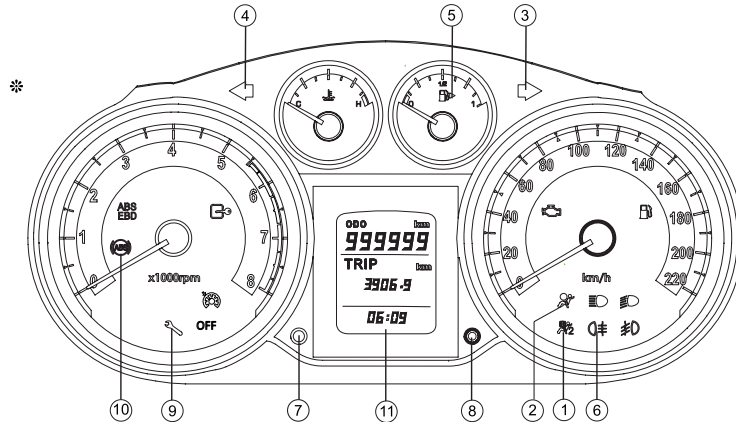
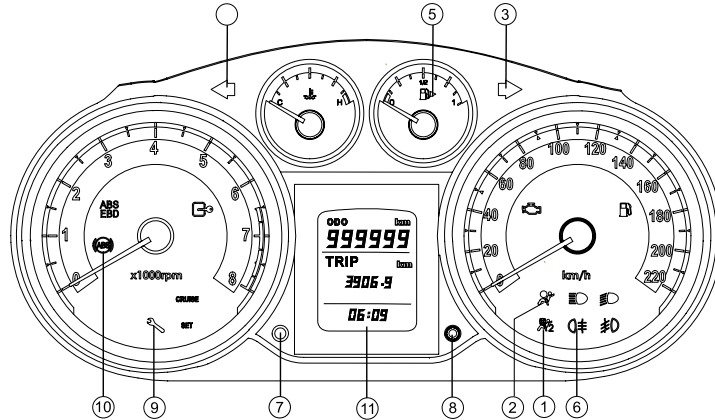

*If installed on your vehicle

THE FRONT PANEL INDICATORS DISPLAY

Fuel rate: The pointer will locate on Zero when the engine is off, and when the ignition switch is ON, this shows the level of fuel. In case the fuel rate is low on the tank (about 8 liters), the fuel shortage light will turn on, which tells you to take action for fuel as soon as possible. The capacity of fuel tank is 60 liters.

Engine RPM: This show RPM per minutes. Never allowed the pointer to be located in red area in order for good maintenance considerations.

3

Speedometer: This shows the vehicle's speed based on km/h.

Engine temperature display: This shows the temperature of cooling liquid. When the engine reaches to ordinary working temperature, the indicator pointer will locate near the middle line and remains there until the engine is operating normally. In case it reaches to red area, it shows overheating of cooling liquid, which may cause severe damages to the engine. In this case, shall stop the car immediately and call authorized branch offices for repair.

Possible reasons:

- Flaw on cooling fan: \implies checkup the fuses and replace each of them necessary.
- Leakage in cooling liquid: \implies wait until the engine is cool, and then test the level of cooling fluid.
- Flaw on water pump operation.

Status modifier and Zero maker key: This is to be used in changing the mode of displaying different items on display and make current statistics as zero.



Indicators lights – Green light

This is to display the indicator to rights and left directions. In turning situations, these lights will indicate simultaneously with vehicle's indicators. In case of using flasher in emergency cases, these lights will also turn on. In case one of the lights is flashing rapidly, this shows flaw on one light.

Caution: This happens only if one of the lights is not functioning in front or back of the vehicle, means that side lights do not have any effect on the speed of these lights.

3

⚠ Necessary tip: These lights will turn on automatically for 5 seconds in case of sudden decrease of vehicle's speed. This is a safety mechanism showing sudden speed decreasing.



Head lights low beam – Green: It will turn on when using front head lights low beam.



Head lights high beam – Green: It will turn on when using front head lights high beam.



Front fog lights – Green: It will turn on when using front fog lights.



Back fog lights – yellow: It will turn on when using back fog lights.

WARNING LIGHTS



Automatic flaw diagnosis light - Yellow light

In case of diagnosing any flaw by this mechanism, the related light will turn on. In case the ignition switch is open on 2nd position, indicating system analysis, this light will turn on and will disappear by powering engine on. In case the light turns on when moving, this indicates a flaw in the engine.

Note: When the light is indicating but the vehicle is operating normally, you shall refer to branch offices. You can also keep running yet. If the light turns on and the vehicle is not operating well, this shows an error in sparking and the engine must work in a very low RPM and you must refer to an authorized representative of IKCO.

3



ABS warning light – yellow

This indicator will turn on and off for a while when you're trying to power on the engine. In case it is not turn on during powering on, or not turn off after powering on the engine, this shows an error in ABS brake system or in EBD system. In this case, you shall immediately transfer the vehicle to an authorized branch office.



Passenger's air bag flaw indicator

If it's turned on constantly, this shows the passenger's air bag is not functioning or inactivating, this will remain on until the issue is eliminated. If it's flashing, you shall immediately call the branch office.



Driver's air bag flaw indicator – Yellow

This will flash for 6 times by powering on the engine, then shall turn off, Or, shows an error in driver's airbag system. Hence, you shall immediately refer to authorized branch office, Or the owner shall bear all responsibilities in this respect.

* If your vehicle is equipped



Fuel shortage indicator light – Yellow:

If this turns on it means that less than 8 liters gas remained in tank, and then you shall take action as soon as possible. This light will flash if the fuel is less than 3 liters.



Cruise control light – Green:

If this turns on/off it means that cruise control system is on/off.



When this light is on or off, it indicates activation or deactivation of cruise control system.



Turning this indicator on and off shows that cruise control system is on or off.



When this light is on, it indicates that cruise control system is deactivated and, if the light is turned off, it indicates that the system is activated.



Immobilizer light – Red:

When the vehicle is switched off; flashing of this light in every 4 seconds, means that the immobilizer is activated.



Service error light – Yellow: If this turns on it means that an error occurred in one of the vehicle's system or it's the time for periodical service. Refer to the nearest after-sale services office if you saw this light.

DIGITAL DISPLAY SCREEN GUIDE

3

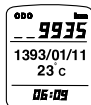
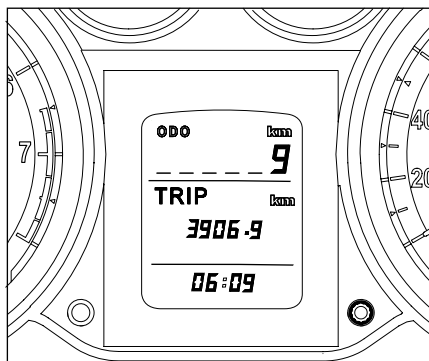

Digital display screen guide:

"ODO" This turns on immediately after ignition switch

in open, this indicates total kilometers went through from delivery of vehicle on km basis, and cannot be changed to Zero. (If it is set for this setting, Or, it is not shown a the time of ignition switch OFF.)

Time, date/ out temperature:

Time range changes from 00:00 to 23:59 with accuracy of 1 minute. The range of calendar changed from 2001 to 2020. Leap years are not considered in the calendar.

The range of temperature is from -40 to +80 degree centigrade.



Average speed

This shows the vehicle's speed from zero time to the current time. By pressing status changing key when the amount is showing, this will change to Zero.



This shows total distance went through from the time you made it Zero on km basis.

Pressing the Zero maker key for 2 seconds will make this distance amount as Zero.

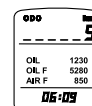

Periodical service

To adjust the km amount to replace the engine oil, oil filter, air filter, press and hold the left key (rotating key) for one second. Then you will enter the sub-menu as shown. You can move through your favorite item, then press and hold the key for 2 seconds in order to determine your favorite number. This will also shows the differential amounts. The accuracy of measurement is for 1 km, periodical service light will be then turned on necessary times.

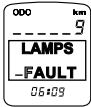

Lamps fault indicator

This lamp will turn on in case of any error in front or back lights.

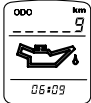

Engine oil shortage indicator

This light will turn on when the ignition switch is on its 2nd position which shows appropriate functioning, and will turn off when the engine is powered on. Or, this shows engine oil shortage, Hence, you shall power off the engine immediately and take action to refer to the nearest authorized branch office.

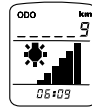

Light rate of lamps adjustment

The background light of lamps will turn on by vehicle's lights. Then you are able to adjust the rate of lights by turning this volume (right side volume) to decrease or increase the light.

The rate of lamp lights is adjustable in 7 options as:

1	2	3	4	5	6	7
20%	25%	40%	55%	70%	85%	100%

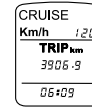

Cruise control system*

The determined speed of cruise control will be displayed on screen in place of ODO, above the screen.

In case of speed change more than 4 km/h, this speed will flash on display screen.

DIGITAL DISPLAY SCREEN GUIDE

3



Instant STOP command

Seeing this command, instantly stop the vehicle without any hesitate then call the authorized workshop.

This lamp may also light up by oil level, battery charge, and engine oil shortage and engine high temperature indicators.



WARNING

If "STOP" light is turned on for any reason, the driver shall avoid running the vehicle and any damage in this case will be borne with the owner.

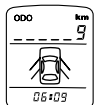

Open doors indicator

This indicates which of the vehicle's 6 doors is remained open, and you shall immediately take action to close it.

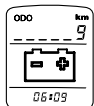

Battery charge warning light

With Ignition switch on its 2nd position, this lamp will light up and immediately disappear by powering engine on, or, it shows an error in battery charge level and you shall take immediate

action to eliminate this issue.

This indicator light may signals for one of the following reasons:

- Flaw on battery charge system
- Flaw on battery or its terminals
- Alternator error
- Flaw on alternator's wires



Driver's seat belt

We shall always ensure appropriate fastening of driver's seat belt by putting the clamp on its metal hole and hearing the click sound. Doing so will turn off this light on display screen. When the vehicle is moving and vehicle's speed exceeds 5 km/h, this indicator light will appear on display and beep sound will be heard for one minute, after which just the light will remains.

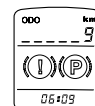

Brake alarm

This will light up in case the handbrake is up or the brake oil level is low.

In case it is not turned on when starting the vehicle or it remains light when the engine is powered on, you shall immediately fill the oil tank and check the handbrake to be down, and then refer to an authorized workshop as soon as possible.

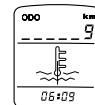

Engine high temperature

You shall immediately stop the vehicle if you saw this light without need to power the engine off, then call an authorized expert. The light of STOP may also appear in case of increasing water temperature.

THE FRONT PANEL AUDIO WARNING

Priority of Audio Alarms				
Type of audio alarm	Operation description	Priority	Start switch	Audio alarm
Non-ending beep	Small lights are on and driver's and/or passenger door is open	1	Engine OFF	Lights audio alarm
A beep after going to rear gear	Going rear gear with sensors functioning well	1	step 2 and 3	Rear gear sensor ready
Continuous beep	Going rear gear with an obstacle near the vehicle			Obstacle diagnosis
A beep after each pressing	When central lock key is pressed for 5 seconds	2		Auto-central lock on/off
3-second beep	Speed exceed 10 km/h and one door is open	3		Open door alarm
3-second beep	Speed exceeds 120 km/h	4		High speed alarm
45-second beep + 15 seconds with twice volume	Speed exceeds 10 km/h and seat belt is not fastened	5		Open seat belt alarm
3-second beep	Fuel shortage light is on	6		Fuel shortage alarm
3-second beep	Engine high temperature light is on	7		Engine high temp alarm
Simultaneous beep and indicator lights	One of indicator lights or flasher is activating. In the meanwhile, indicator display in control panel is activated with double frequencies when one of the lights are damaged and one of the indicator light is activated.	8	All status	Flashers alarm

CRUISE CONTROL

Cruise Control

This mechanism is designed to keep the vehicle's speed fixed in long ways.

You will be able to fix your speed without any need to press the gas pedal.

When the cruise control is activated, actually an electrical driver will borne the responsibility of adjusting gas channel, and the main driver will not have any need to press the gas pedal.

The Driver is also able to increase/decrease the vehicle's speed by pressing the keys designed on related panel on the steering wheel. In case the driver presses the clutch or gas pedal(s), the cruise control will be cancelled. Then the Driver will be able to continue speed control and the latest speed will be stored in system's memory. Also the driver is able to press the gas pedal to increase the speed. The indicators of cruise control on display screen show the activity of this system.

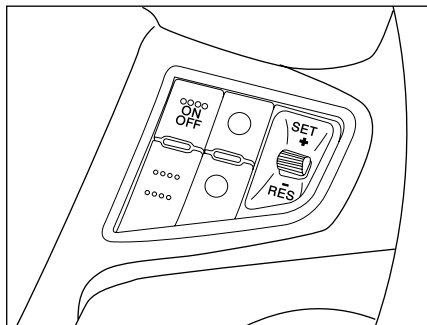

Main Components of the system

1. Throttle (electric gas inlet), which controls the opening of gas inlet and is installed on engine compartment.
2. Electrical control unit (ECU)
This unit performs information process and control tasks. This is installed on engine compartment.
3. Steering wheel panel keys
The Driver will be able to control the system through the instrument panel installed on the steering wheel.



System manual



Gears upper 4 are designed to be control by cruise system.

Vehicle's speed shall exceed 42 km/h



The key (ON/OFF) on steering wheel panel is designed to power on/off the cruise control.

The indicator  will turn on with green light on the display when the system is activated.

When the system is ON but not activated, pressing the brake pedal for first time after powering engine on, the key  will activate the system, and the vehicle's speed will remain still. The indicator  will be displayed by activating the system.

When the system is activated, pressing and holding  will increase the vehicle's speed for 3 km/h per second, and releasing the key  will fix the speed. Each pressing will also increase the speed for 1 km/h.

If the system is not activated, pressing the  key will activate the system, and the vehicle will move with the previously stored speed, if nothing, based on the current speed.

When the system is activated, pressing and holding the  decreases the vehicle's speed for 3 km/h per second. Each pressing  will decrease the speed for 1 km/h per second.

*If equipped

Benefits of using Cruise control system

- 1. More convenience at driving and keeping the energy of foots specially in long journeys in express ways due to no need for pressing the gas pedal.
- 2. Brilliant decrease in fuel consumption
- 3. Avoid violating the legal speed in roads which are sometimes unintentional.

Condition of cruise control activation

- Cruise system is ON (with ignition switch and ON/OFF key)
- Pressing one of SET or RES keys
- Being the determined speed range (42-150 km/h)
- Appropriate gear for cruise (upper gear 4)

Instant inactivation of Cruise Control System

- Pressing brake pedal
 - Pressing clutch pedal
 - Pressing OFF/ON key
- Powering off with main ignition switch (intentionally by driver or unintentionally due to cruise module error)
- Changing the gear (manual gear)

- Engine speed is less than than 42km/h
- Vehicle speed is more than 152km/h.
- RPM is less than 1500mm
- RPM is more than 5000mm(1500-5000)
- Not being in 4 or 5 gear.
- Fuel cut due to safety considerations
- Positive or negative acceleration of vehicle is out of permitted range.
- Brake pedal signal error
- Vehicle's speed being 10 km/h upper than the set speed for 9 0 seconds
- Vehicle's speed being 20 km/h lower than the set speed for 90 seconds



WARNING

Conduct a whole vehicle's control when using cruise control system. Pay attention that cruise control system is designed for express ways, highways, direct and long roads with light traffics.

Avoid using cruise control in these cases:

- Heavy traffic roads
- Meander roads
- Slippery roads
- Roads with high slope
- Rainy roads

As the cruise control does not have any control on brake system, the vehicle's speed may exceed the determined amount. Hence, the vehicle's speed shall be control by the driver in roads with high slope.

POWERING ENGINE ON AND DRIVING

Powering Engine On

1. Make sure that the handbrake is up and the gear is on N mode.
2. Power off all unnecessary electrical devices like cooler.
3. Turn the ignition switch to 3rd position, then immediately release it.

Never press the gas pedal when trying to start and never continue starting for more than 15 seconds. If you did not succeed to start, pause the operation for 10 seconds, then retry.

If engine did not power on, or malfunction after starting

- Press the gas pedal to half length (try only for 15 seconds)
- If you did not succeed, now press the gas pedal completely then retry to start, so that extra gas will be removed from the engine (try only for 15 seconds)
- Avoid pressing and releasing gas pedal when trying to start the engine.

Cold climates

In -10 degree centigrade, the vehicle needs more time to be started. Hence, power off all electrical devices when trying to start.

Engine's warm up

Immediately start to drive when the engine is powered on, due to fuel decrease considerations, but pay attention not to drive speedy up to the time the engine warms up.

Vehicle parking

Always pull up the handbrake and put the gear on N mode before parking.

Sealing

Engine, gear box, brakes, and rubbers need time to be sealed and fixed on their appropriate place.

Please observe the following considerations in at least the first 1000 kilometers:

- Never allow the rpm to exceed 3000 in any gear
- Never press the gas pedal on any gear

- Never allow to inflict force on engine in any gear
- Avoid sudden brakes if possible
- Using high rpm after sealing period is not limited.



Caution

Never park your vehicle near flammable materials like leaf, feed, especially when the engine is ON.

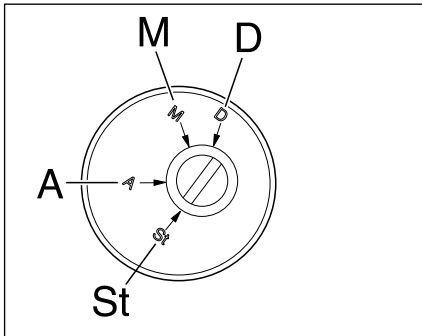

Unlocking steering wheel's lock

After inserting ignition switch, slowly move the steering wheel and turn the switch to put it into 1st position, then you see the steering wheel unlocks.

Locking steering wheel

After removing the ignition switch, turn the steering wheel on pedestrian's side, you see the steering wheel locks.



WARNING

When the vehicle is moving, avoid powering off or removing the switch, because the steering wheel will be locked and the vehicle will get out of control.
Avoid keeping the engine powered on in the roofed places for long times.

Ignition switch modes:

St Mode:

You can remove the switch
The steering wheel is locked
Most of the lights including side lamps, head lights and flashers function

A Mode:

The steering wheel is not locked
Some of E-components function

M Mode:

All equipment including indicator lights and electrical circuits function

D Mode:

The engine can be started. Immediately release the switch after powering on, the switch will return to M mode automatically.

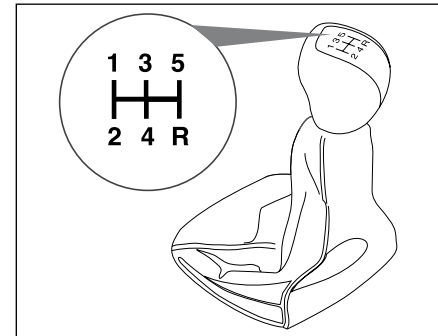

Gears positions

The different gears positions are shown in the above image. This vehicle is equipped with synchronization system on all gears.

Precautions of driving

- Never make use of the gear lever as a backrest because this will reduce the useful life of the gears mechanism. Never make use of clutch pedal as foot back, because this will result in mechanical issues.
- Never make use of half clutch technique to stop the vehicle in slope roads, because this will result in mechanical erosion of clutch system.
- Avoid driving with heavy gear for long times
- Driving with heavy gear will increase the fuel consumption, the more rapid gear changing, the better maintenance of the vehicle's engine.

FUEL CONSUMPTION REDUCTION AND ENVIRONMENTAL PROTECTION

Fuel consumption reduction and environmental protection

You can reduce the environmental pollutions and fuel consumption by observing the following tips:

- Make use of the gas and engine oil advised by the manufacturer
- Never allowed leakage of gas at stations
- Never forget periodical services
- Checkup exhaust system and those of fuel and oil for any leakage
- Start moving after powering on the engine
- Power off the engine in stops more than 2 minutes in traffic, etc.
- Press the gas pedal so slowly, try to keep still the vehicle's speed for better mechanical efficiency
- Pay attention to the maximum speed limitations
- Adjust the tires air pressure periodically and make them balanced.

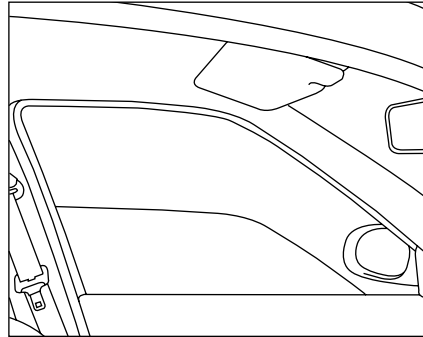

- Make use of cooler just in necessary cases, this will reduce the fuel consumption
- Never throw out the used engine oil if you want to replace the engine oil by yourself, but deliver it to mechanical workshop for recycling purposes.
- Plan for your travels to reduce them
- Avoid driving at rush and busy hours and streets if possible
- Turn off your unnecessary electrical equipment but pay attention that safety is at first priority, so turn on the lights as soon as dark comes.

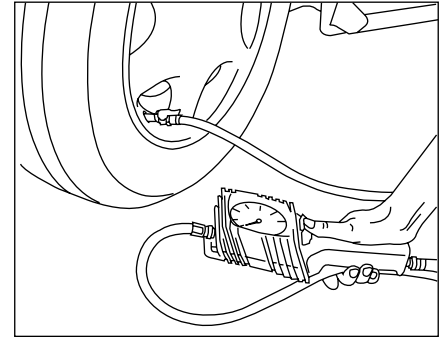

- Make use of air inlets designed on dashboard to have fresh air instead of opening windows if possible
- Avoid fastening unnecessary barn on the vehicle
- Making use of tires not approved by the automotive company will increase the fuel consumption
- Flat tires will severely increase the fuel consumption.

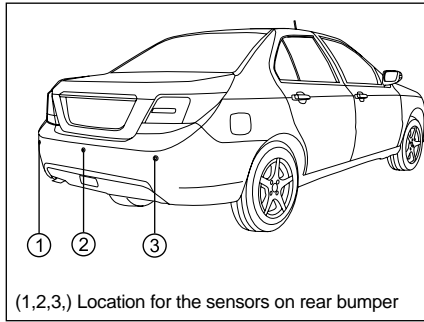

Back obstacle warning system

This system includes three smart sensors which are designed on the vehicle's bumper, and are connected to the E-network of the vehicle.

Performance

The above system will inform the driver of any back obstacle in two ways of visual (through display) and audio (through beep sounds).

With the ignition switch open, and Rear gear, this system will be activated which will be declared to the driver by a short beep and lighting up the back segments on the display.

The display segments will be on until an obstacle stands in 150 cm distance from the vehicle as above image and no beep will be heard. When the vehicle goes

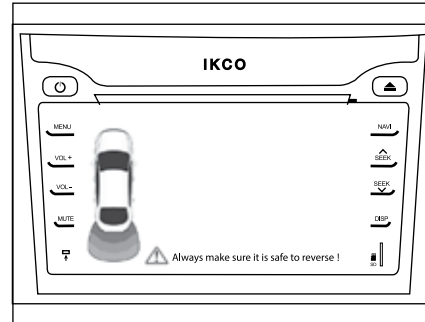

nearer to 150 cm to an obstacle, the side related segments will be turned off on the display and the beep sound will be heard. Going nearer to the obstacle will cause the beep to volume up and more segments will be turned off.

The beep sound will be heard continuously if the beep sound is nearer than 50 cm, and the first row segments will flash on the display for more warning of the driver. The vehicle shall be stopped in this moment.

Sensor fault warning

In case of arising any fault in the sensor, the warning message of "Sensor Fault" will be shown in place of clock on the screen and the sensors operations will not function anymore.

In this mode, three short beep sounds will be heard.

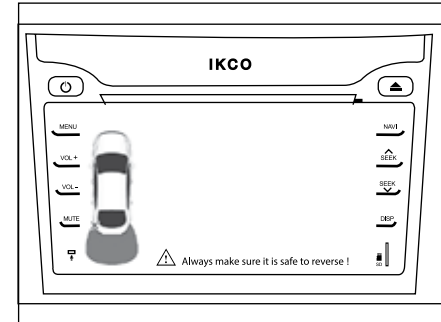

WARNINGS

This system is designed to help the driver in diagnosing the obstacle in 150 cm distance from behind the vehicles specially at parking with the speed less than 5 km/h, and naturally has some limitations; hence, the driver's care shall be the first priority.

Making use of audio signals, this system will help parking positions and determination of objects when the vehicle is running on rear gear.

Hence, having this system shall not be result in heedless driving on rear gear and sudden moves.

The Driver shall always pay attention to back obstacles, mobile obstacles like children, carriers, bicycles, animal, etc., or short and narrow obstacles like tables, narrow fences shall always be at the focus of driver's attention.

REAR VISION CAMERA

3

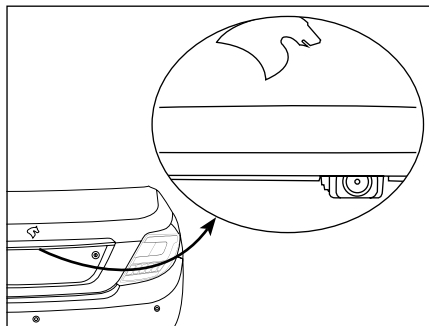

Rear vision camera *

By putting the gear in reverse position a perimeter view of the back along with a graph will be displayed on the screen; By reaching to the red area, use the rear bumper picture for exact stopping.



WARNING

Ensure that the rear camera is not covered by the mud, snow and dirt.

* if your vehicle is equipped

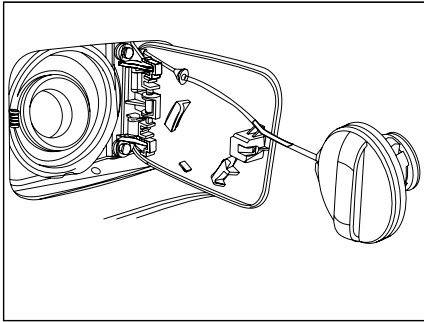

Fuel tank cap

To open the cap, turn the fuel tank cap counterclockwise, and wait a moment to allow gases to release, then completely open it up.

To get more information about allowed gases, please refer to the manual attached to the cap.

The cap is attached to the tank with a special rope in order to avoid missing the cap.



CAUTIONS

The allowed gas for your vehicle is actually the unleaded gasoline with octane 95%, in case of making use of any gasoline except that, this will result in internal components mechanical damage which will lead in ignition phenomena.

Gasoline additive is not allowed for this vehicle
Never put the gas nozzle completely into the tank.

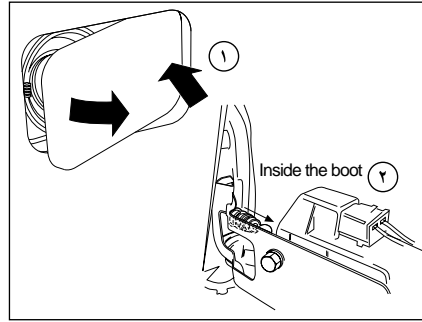

Fuel tank cap

The fuel tank cap is located on right side of the back fender and is connected to the central lock. When the central lock is open, push the right side of cap to open it up.

Opening the fuel tank cap in emergency (2)

- In case of central lock failure, you will be able to open the fuel tank cap from inside the boot.
- Pull the cap clamp backwards.

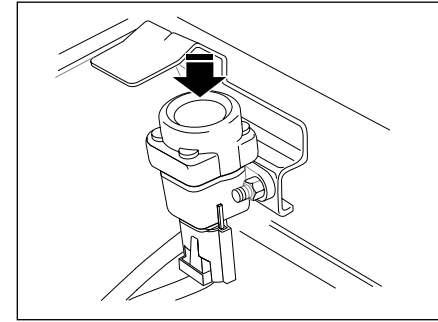

Fuel reconnection key

The fuel reconnection key is located on the hood, on the right internal fender. In severe accidents, a safety system will cease the fuel transfer to the engine, which you can reconnect this by pressing this key after making sure that no fuel leakage exists.



WARNING

The gasoline in the tank may be pressurized. Hence, never open up the can suddenly, actually it shall be opened slowly to allow gases to be released.
The gasoline steam is so dangerous, when the fuel is pouring into the tank, the engine shall be powered off and the vehicle shall be far from any spark, flame, cigarette, and matches.

LIGHTS AND INDICATORS

3

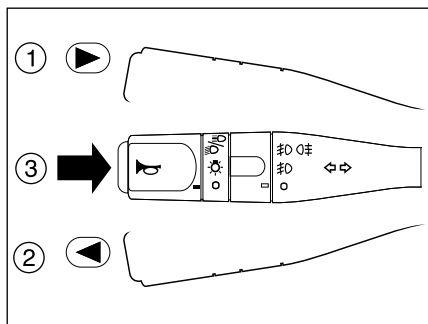

Left and right indicators

Status 1 and 2: pull the level down before turning to left, and pull it up before turning rights. The green indicator light of turning signal will be shown on the display according to the related direction.

Knocking on the lever on each direction will activate it for one flash then will disappear (number of flashers can be adjusted by the troubleshooter)

Horn

Status 3: push the key at the tail of the lever to horn.

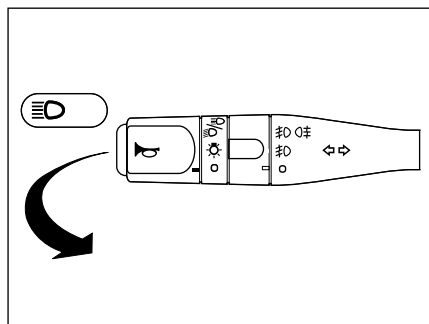

Low and high beam

Pull the lever towards steering wheel to change the low and high beam. (the blue light indicate high beam). pulling the lever towards the steering wheel shortly and its releasing will flash the high beam for one time.



WARNING

Whenever the driver decides to change his line in motion; It is enough to give a small touch to the indicator lever towards down or up, in this case, the pilot light gets on 3 times as a warning light.

Warning beep:

This beep declares the driver that the headlights are remained turned on when he or she is leaving the vehicle, and will be heard when the driver's or passenger's door is open and the ignition switch is OFF.

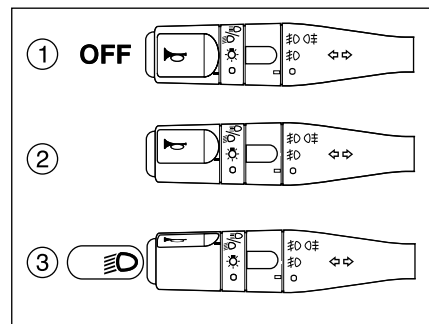

Lamps key

Status 1: all lamps off

Status 2: small, back, display and dashboard lamps

Status 3: head lights ON

DRL - light

Day-Time Running Light gets on automatically, once the vehicle is turned on, and it will be disabled by activation of any lamp like indicators, beam lights or deep lights etc. Another light such as a guide or position light or low light will be disabled. This is why you are seeing better.

Activation / deactivation of this light must be carried out by IKCO authorized dealers.

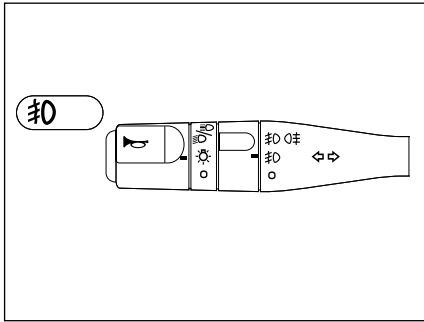

Front fog lights

Turn up one step the middle part of indicator lever to turn on the front fog lights. This will light up an indicator on the display screen. These lights will be turned on only when the small lights are on.

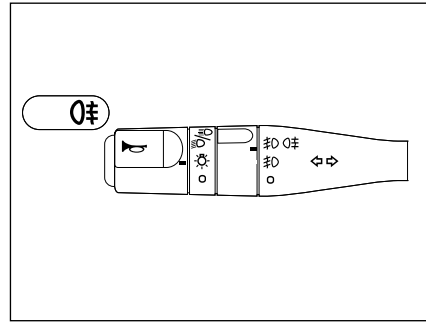

Back fog lights

Turn up two step the middle part of indicator lever to turn on the back fog lights. This will light up an indicator on the display screen. These lights will be turned on providing that:
only when the small lights are on.

Try to make use of these lights **only** in places with low vision, because in other cases, these will procure vision interruptions for other vehicles.

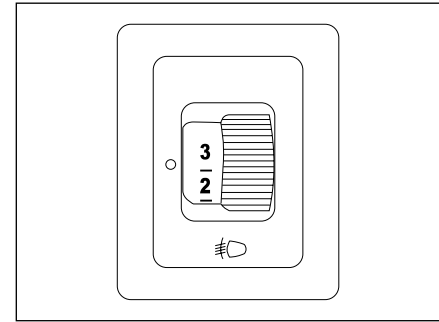

Adjusting headlights height

By this mechanism, you will be able to adjust the height of headlights with respect to the load in vehicle and subsequently increase or decrease of the vehicle weight.



WARNING

Precautions of driving at night

Always make sure the appropriate functioning of lights and electrical equipment and adjust the lights. In case of vehicle's overload, special care shall be focused not to cover the lights by any object including dirt, mud, snow, etc

Use the fog lights only in snowy and foggy weather or when it's really necessary and don't let it be on for a long time.



CAUTION

It's better to change the status of lights with a short pause in each 1,2 or 3 modes.

SNOW WIPERS AND GLASS WASHING

3

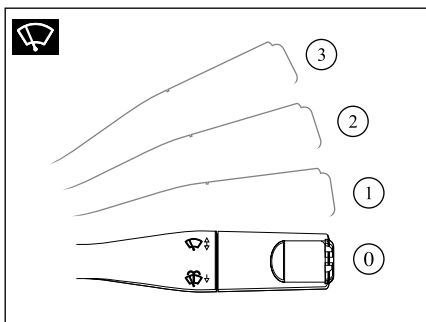

Snow wipers

The snow wipers and glass washer can be controllable through the lever on the right side of the steering wheel when the ignition switch is open.

0- Snow wipers OFF

- 1- Snow wipers ON with timer (speed of wipers move will be arranged by the vehicle's speed)
- 2- Slow speed
- 3- Rapid speed

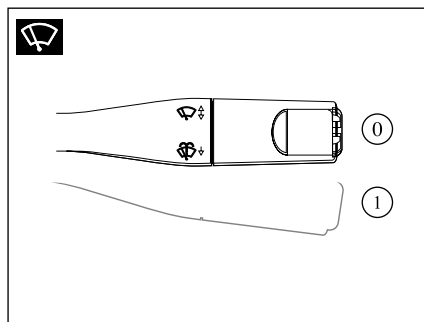

Single cycle of snow wipers

This works by pulling the related lever once downwards.

Holding the lever down will make the movement continuous.

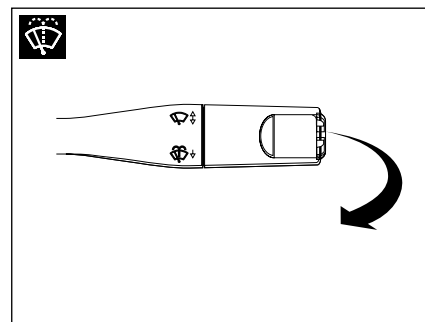

Glass washing

This works by pulling the lever towards yourself, on pulling it will make it to cycle for three times, continuously keeping the lever will make the movement continuous. The water will be sprayed immediately by pulling the lever, for 0.7 seconds, then the wipers will cycle. Continuous pulling will make the cycle and water spraying continuous. The fourth cycle for complete cleaning will be started after 3 seconds.



CAUTION

Make sure that the wipers are not frozen at freezing climates. (risk of warming up the snow wiper motor)

Analyze the status of wipers; replace them in case of malfunction. (each year approximately)

Clean the windshield regularly, if you power off the engine before complete cycle of wipers, the wipers will remain in their current position.

When opening the hood, make sure that the wipers lever is located on 0 position. (risk of injury)

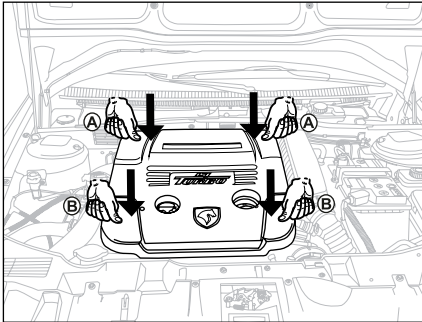

TURBOCHARGER

Turbocharger is one of the most advanced technologies in modern internal combustion engines. This system uses energy of the hot engine gases or outlet fumes and by rotating the turbine blades, compresses the filtered air through compressor blade connected to the turbine. It causes the decrease of fuel consumption and increase of engine power remarkably by entering into the engine after being cooled through intercooler.

This technology is used normally in the line with achieving two goals, namely; applying in races and to reduce fuel consumption. In present vehicle it's to be used for just reducing fuel consumption abreast of increase of engine torque and power.

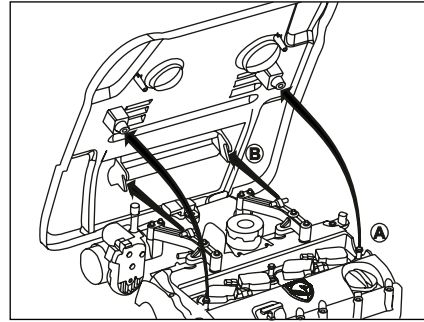

Turbocharger works under engine load of the vehicle with a very high RPM nearly 200,000 RPM; Hence it is equipped with hyper lubrication and cooling system. Therefore the safety tips must be regarded due to very high speed of blades and sensitivity of bearing to prevent damage to the engine causing increase of engine durability.

Removing of decorative engine cap

- Take the cover on both sides of its front part(your own side) and pull up Slightly so that the front staples are released.(A)
- Then slide it towards your chest with a steep angle so that the rear stapled get also released (B)

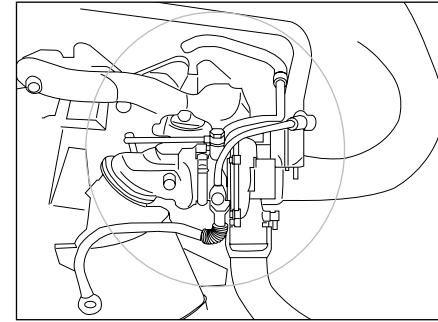

Inserting of decorative cap of the engine

- Keep the cap a little sloping, so that the rear grooved bases are visible in such a way to be adjusted in two catches of seating location of base.
- insert them in their own places by a little pressure on the cap on two rear bases zone, (A)
- Check the adjustment of oil gauge access point and engine oil cap from the holes on it to ensure about the correct position of the cap.
- Insert the cap on two front bases zone, by a little pressure on it.(B)

* If equipped with your vehicle

Turbocharger

Turbocharger Safety Tips

1- Any leakage of water or oil from the engine must be specially cared and immediately refer to authorized dealers for IKCO , if you observe any case.

2. Having air leakage from high pressure air pipes and intercooler causes reduction of power, increase of fuel consumption and increase probability of damage to the engine. So we must ensure about the tightness of the fastening of the airways, connections and the lack of any damage to the pipes. And leakage test must be done at the time of referring to the authorized dealers of IKCO.

-3 The air filter must be timely changed according to the instructions due to the sensitivity of the blades to the outsider and rapid moving particles; replace the air filters in short intervals if the vehicle is used in areas with excessive dust and pollution. The same considerations should be taken also in the case of oil filters.

4- Avoid the danger of engine in being “on” position, while pipes connected to the air path, are open due to very high rotation of turbocharge. in addition, manipulating the blades or putting pressure or any strike and impact to them will cause damage to it.

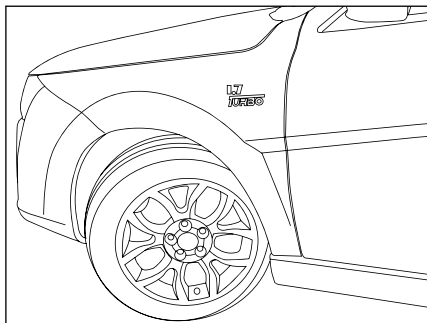

5- Allow the vehicle start working in idle position for at least 30 seconds in following conditions:

- In case the vehicles has been stopped for more than one day and.

- Soon after changing the oil or filter.

- When the engine temperature is too low. in following conditions allow the vehicle start working in idle position for at least 60 seconds:

- When the engine temperature is too high or you've traversed a very long distance result in high temperature of the engine.

6- In case the yellow light check of the engine  is turned on you must immediately refer to the nearest authorized dealers of IKCO and avoid traversing a long journey by your vehicle

in this situation.

-7 Check the engine oil and water level periodically and before every journey.

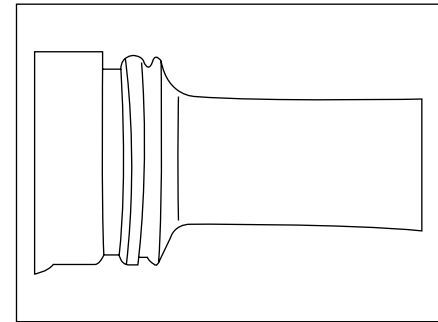
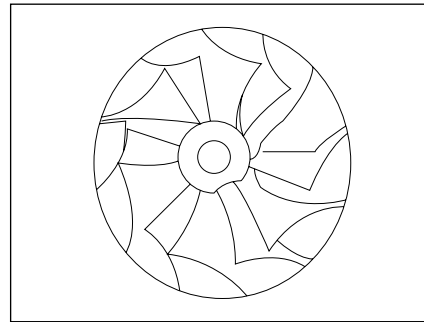
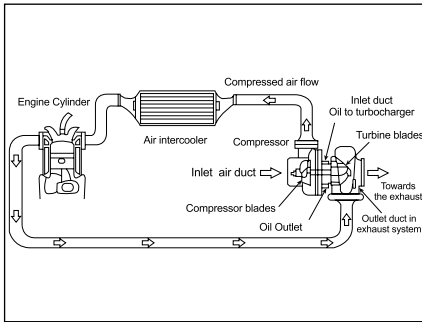

Maintenance of Turbocharge Inappropriate lubrication and damage to the Turbocharge shaft

1. Accuracy in the amount of injected oil to the engine as recommended by the Manufacturer)
Oil leaks from turbocharger due to more use of oil and inappropriate lubrication due to less oils and not being as per standard level.
(The oil level should not be less than its standard level with respect to the oil gauge (not more than Max. and not less than Min)
2. Accuracy during oil change ,oil filter and oil type according to manufacturer's recommendation (Lack of lubrication and improper filtration due to use non-standard oil and oil filter)
3. Ensure the absence of any contamination, the exterior particle and dust on pipes, around turbocharging and the location of the air filter before proceeding to service.
Any exterior particle, dust and so on are

- cleaned by wind pressure before unlocking the fittings of the air duct collection.
4. Damage to compressor blades due to The presence of dust in the air inlet duct
4. Care must be taken at the time of replacing the spark plugs according to the manufacturer recommendation.
Plugs type must be according to the manufacturer company's recommendation (lack of proper and timely combustion and probability damage to Turbocharger Turbine Blades.)
5. Any leakage will reduce pressure in the pipes (All air transferring conduits from the Turbocharge to the gas valve) Therefore, the turbocharger shaft rotation and its temperature subsequently increase to compensate pressure reduction which is due to leakage and It causes damage to the Turbocharge system.
6. Avoid of casual pressing of gas pedal

before turning off the engine. It causes serious damage to the turbocharger in seconds. Because the oil of turbocharger (supplied by the engine) which has got a very high rpm (average 100000 rpm as compared with of engine rpm which is about 2000 to the Max. of 3200 rpm) will be cut by sudden shutdown of the engine ;And its outlet oil which is still in the outlet duct will be burned and converted to coal coke and will cause blockage of outlet duct. Then in next starting of the engine the input oil which is under pressure does not exit and pushes the turbocharger shaft Causing abrupt shaking and the transfer of coal coke into the compressor shell result in breakage of the blades and scrape of the shell. To avoid this problem drivers must turned off the vehicle for at least two minutes after the engine works in idle position

BRAKES

3

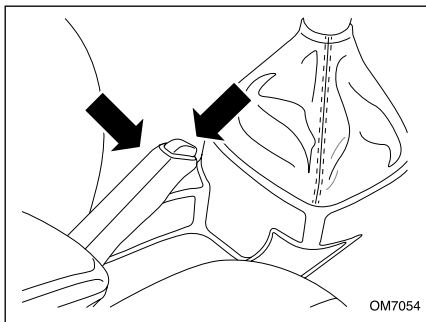

Handbrake

The handbrakes only lock the back tires. Pull up the handbrake to activate it. Pull up the handbrake completely after each parking without pressing its tail key, this key is used when you want to release the handbrake. When you release the handbrake, its indicator light will be disappeared.

In slope roads, further to pulling the handbrake, the driver shall put the vehicle into gear, i.e. gear 1 or gear R, in accordance with the slope direction.



CAUTION

When you are driving, always make sure that the handbrake is released, because its being up may cause brake components warm up and mechanical issues.



CAUTIONS

Turn the tire on pedestrian side when parking at a slope place, then pull up the handbrakes.

Indicating the icons of (I)(P) and **STOP** on the display shows that the handbrake is not released, or released inappropriately.

The performance of ABS is not dependent on the inflicted force of the pedal, and it is advised to inflict a high force on the pedal at emergencies. This is not required to press the pedal consecutively (to fill in the brake pump)



WARNING

When the engine is powered off, more force shall be inflicted on brake pedal for braking. Always ensure appropriate functioning of all components before starting to drive.

Anti Lock Braking System (ABS)

This is a mechanism to prevent wheels locking when pressing the brake pedal, so, the brakes will perform better and there exists more control on steering wheel, finally causes more safety for the vehicle and passengers.

When the wheels are quivering on brakes, there exist risks of loss of control specially in slippery roads. Now, the necessity of using ABS brakes become more evident. This system has a special role on controlling the inflicted force of brakes electronically and actually will adjust its level with the road level changing status.



In hydraulic brake systems, pressing the pedal will cause ever-increasing force on the wheels which may cause locking. Modern brake mechanisms like ABS, actually prevents wheels locking and brings us more safety. ABS has actually control on each wheel separately at the time of braking, control the force inflicted on electronically and prevents wheels locking, which will cause a great safety at braking times specially in slippery roads in respect of vehicle's steering.

The benefits of ABS system can be summarized as follows:

1. Better steering capabilities and more stability at braking times (in straight and winding roads)
2. Better performance of steering wheel at braking (in straight and winding roads)
3. Reducing the responsibilities of the driver
4. Avoid tires erosion in respect of persisting against locking and glide of tires.

ANTI LOCK BRAKING SYSTEM (ABS)

Observe the following tips if your vehicle is equipped with ABS system:

- Whereas the ABS is actually a force balancer, so, pay attention to inflict enough force, not extra force, to the pedal.
- A quivering feeling of pedal on slippery roads is natural and is arising from anti-lock system.
- Hearing brake sounds of wheels specially on slippery roads is natural which is arising from the operations of ABS system. In case of any error, the messages of  will be shown on display.
- The indicator of  will be shown when starting the engine, but it shall surely disappear.
- When the light is not turned on at start time, or remained turned on, this indicates any error. In this case, try to transfer the vehicle to an authorized workshop.
- If both indicators of  lights up simultaneously, try to stop the vehicle immediately and transfer your vehicle to the nearest authorized workshop.

When driving at slippery roads, pay attention that the brake time may last more. If passing water passages or washing your vehicle, try to brake several times to help the brake system come back to normal status.



WARNING

Having been equipped with ABS system shall not be deemed as a factor for speedy driving, actually ABS will not do anything for safety, and the Driver shall take care of his/her driving behaviors.



Just like ordinary brake system, more pressing force of pedal in ABS systems will increase the brake force.

Electronic Brake Force Distribution System

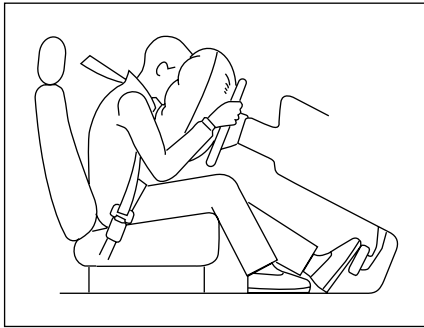
The EBD system will actually arrange the rate of brake force in front and back wheels, and prevents more force on one side. This mechanism actually creates an optimized brake force in both front and back axles, and creates brake force distribution on four wheels simultaneously and brake efficiency becomes maximum. Also, making use of EBD, the force valve can be omitted and EBD guarantees the optimized brake force distribution on four wheels.



Air bag safety

Your vehicle is quipped with Air bag in addition to the pretensioner seat belt. The Air Bag is activated and protecting all passengers soon after the accident. When the ignition switch is turned to the "ON" position, air bag indicator on the instrument cluster gets on   and will get turn off again after blinking for 6 times.

Please refer to the authorized representative of IKCO, in case of observing any changes in indicator functions.



Warning

The following situations are indicating certain errors in air bag system or seat-belt, and you should immediately refer to authorized representative of IKCO.

- Indicator lamps will remain in on position after 6 times of flashing
- Indicator lamps are not getting on while the ignition switch is in on position.
- Indicator lamps are getting on while you're driving.

The responsibility of any accident will be on count of vehicle owner, if he/she doesn't refer to the authorized representative of IKCO.

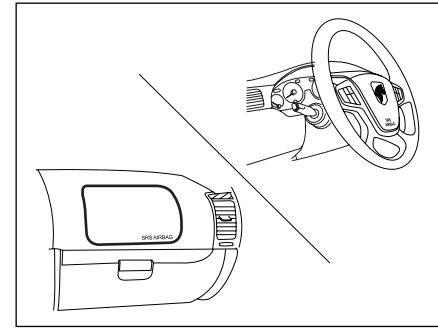

Driver and Passenger Airbag

Driver Airbag is located behind the central cap of steering wheel. SRS AIRBAG has been carved on it to indicate the presence of the Air bag. Passenger Airbag is located in the top right of the dashboard. SRS AIRBAG has been carved on it.



Warning

Air bags are not operating while the vehicle is off and the ignition Switch is in off position.



Warning

Covering of air bags area and pasting any object such as label (clock, mobile phone base, etc.) are forbidden. Putting objects in front of the chair in such a way that prevents passenger to sit down normally or cover the air bag It's dangerous.

AIR BAGS

3

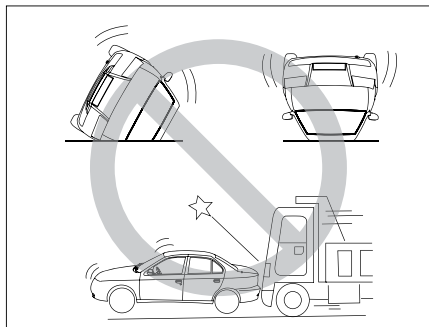

Important Note:

The front row airbag in the vehicle is designed in such a way that operates from front section and only during an intense crash; And it doesn't operate in the event of backside, lateral and rollover crashes or in light accident. This safety system has been designed to reduce the injuries and harms for passenger and driver and safety protection of them.

The airbag can only act once in a single crash. And it gets filled and empty so fast that you may not even be aware of its activation.

Activation of the air bag prevents your vision and it's not too tight so as not to allow you to get out of the car.

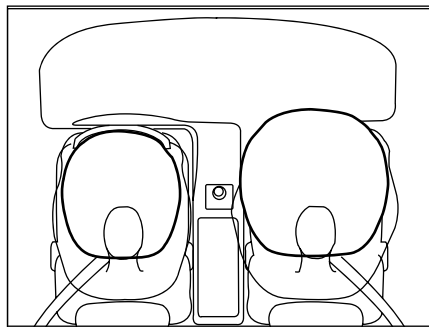

When the airbag is opened, a loud sound are created and a small amount of smoke is getting out without creation of any harm for the people.

Of course it may cause temporary irritation of throat or skin for the people with respiratory illness or those who have sensitive skin.

Avoid smoking during driving.

The fire of cigarette can cause serious injury when the airbag gets open.



Warning

It's necessary to know that no system can protect passengers against all possible injuries in a collision.

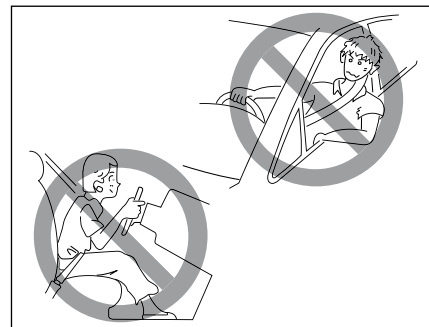

Relation between appropriate sitting and function of air bag and seat belt.

The air bag has maximum protective effect when the safety belt has kept your body in the proper position. So always adjust the seat in the farthest position possible, sit with a straight posture and lean on the backrest.



Warning

Air bags, safety belts, crash protection system are complementary. The driver and all passengers must be closed at all times your safety belt to the risk of serious injury or death in the event of an accident are minimized.

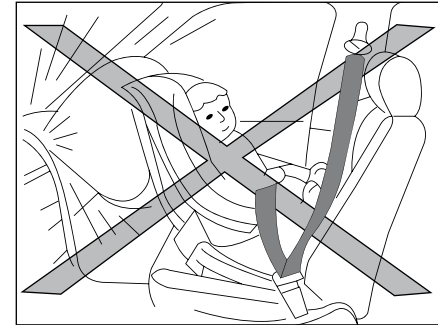
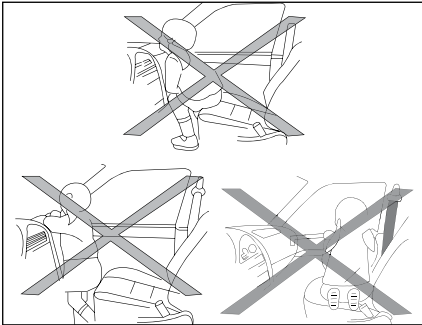

3



Warning

In the event of an accident, there is serious injuries for driver and passengers, if they don't wear a seat belt bend forward, or are positioned out of the chair.

Holding the driver's hand on the blades or central parts of the steering, placing legs on the dashboard and being too close to the airbag, will cause injury to the passengers in the accident while creating functional impairment of safety system.

Disabling of the passenger airbag

Disable Key of the passenger airbag is located on lateral side of dashboard section and provides the possibility of activating or inactivating passenger air bag.

The warning light of deactivation mode is turned on, on instrument panel (🚗), if the Air bag is deactivated.



Warning

Enabling or disabling front passenger airbag Should be done, when the vehicle is in off position.

The relevant warning light of deactivation must be turned off (🚗) Immediately after reactivating the Air bag.

As shown on the label beside the key, you should avoid placing the baby seat on the front seat towards the back of the vehicle, when the passenger air bag is activated. If it's necessary to use the baby seat in front seat, you must either deactivate the air bag or place the baby seat towards the front side of the vehicle.

However none of the above cases are recommended to be done .

Seating of passengers on front seat is totally dangerous while the key is in off position .

please refer to the relevant section of this manual to check the safety points of children.

AIR BAGS

3



Warning

Do not allow children to seat in the vehicle without protection or take their hands out of the vehicle.

Do not put children on your feet and don't hug them. The possibility of severe injuries are there, if the children are not properly protected or if child seat is placed inappropriately in the front seat.

Do not install rear-facing child restraint system on the front passenger seat when there is a fault in function of the air bag arming or disarming switch.

Any servicing on the passenger security system (pre-tensioner, air bag, electronic control unit, wiring) or re-use of this system in another vehicle, even if it is the same vehicle, is expressly forbidden. Use of standard components is strictly mandatory.

After any accident, the safety system must be rechecked. Any repairs, operations, and rechecking of the safety system must be done by authorized dealer of IKCO.

SERVICE AND MAINTENANCE

If the air bag operates once, all its components must be replaced by authorized dealer of IKCO.

Scraping of the vehicle without removing of the air bag is very dangerous. Refer to the authorized dealer of IKCO to eliminate all activating armors of seat belt and air bag.



Warning

For information on checking periods or changing of air bag and safety belt refer to warranty manual.

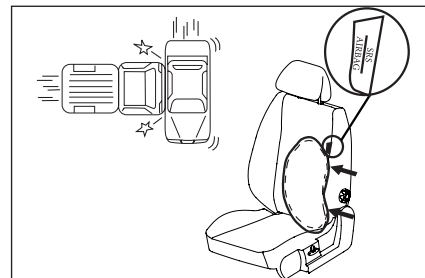

Side air bag *

Side air bag is located on the outer side of the driver and passenger seat in order to protect them.

Side air bag operates only in case of severe collision from the sideward and its proper functioning depends on the closure of seat belt.



Warning

Always make sure the side bags are opened easily when needed.

Use of seat covers and hanging equipment and unnecessary facilities on the front seat or covering the outer part of the seat by any means can prevent the correct operation of lateral air bags.

In order to provide special covers for the seats equipped with air bag, refer to authorized dealers; if really you wish to use the seat cover. Avoid washing or wetting front seats.

* If equipped with your vehicle

4 VEHICLE MAINTENANCE

MAINTENANCE	100-101
ENGINE COMPARTMENT	102-110
CAR WASH	112-116

MAINTENANCE

Maintenance considerations for the Owner

In addition to regular and periodical services and repairs, some simple considerations are advised herein for more maintenance which are to be done by the owner himself/herself.

Daily monitoring

- Performance of the lamps, indicator lights, snow wipers, glass washers, and warning lights.
- Performance of seat belt and brakes
- Leakage of any liquid which shows any liquid leakage.

Weekly monitoring

- Level of engine oil
- Level of coolant
- Level of brake oil
- Level of hydraulic steering wheel oil
- Level of glass washer liquid
- Level of tires air and its conditions
- Performance of cooler

Special conditions

In case your vehicle is permanently parked in dusty areas or in cold climates, it will need special cares which may be advised by authorized workshops.

Ordinary services

Safety, reliability and performance of your vehicle depends directly to its manner of maintenance. The responsibility of vehicles maintenance shall be borne with the owner. Always make sure that the engine oil, monitoring, brake oil and coolant are appropriate.

Safety in garage

In case of necessary need for repair in garage, please pay attention to the following tips:

- Keep your hands and clothes away from mobile parts.
- If you powered off the engine right now, avoid touching hot parts like exhaust, engine's coolant liquid and its tools.
- Never touch the engine and other electrical parts when the engine is powered on or the ignition switch is open.
- Avoid powering on the engine on roofed areas because of risk of exposing toxic gases.
- When the vehicle is lifted only by a jack, avoid mechanical actions beneath the vehicle.
- Make sure that uncovered wires and other electrically dangerous tools are away from the engine.
- Make use of special uniforms at the time of mechanical actions.
- Put out your jewelry and bracelet when performing mechanical actions on the vehicle.
- Avoid touching or attaching the battery terminals with metal tools.

Toxic materials

The liquids used in the vehicle's engine are totally toxic, hence, avoid contacting them with your body, these liquids include battery acid, anti-freezing, brake oil and hydraulic steering wheel oil, gasoline, engine oil and additives of washers. Pay attention to the manuals attached to these materials.



WARNING

- Always keep eyes on the level of engine oil if your vehicle is running at high speed with most of the times.
- Any kinds of unusual liquid shortage or tires erosion shall be reported to mechanical workshops of IRAN KHODRO.

ENGINE COMPARTMENT

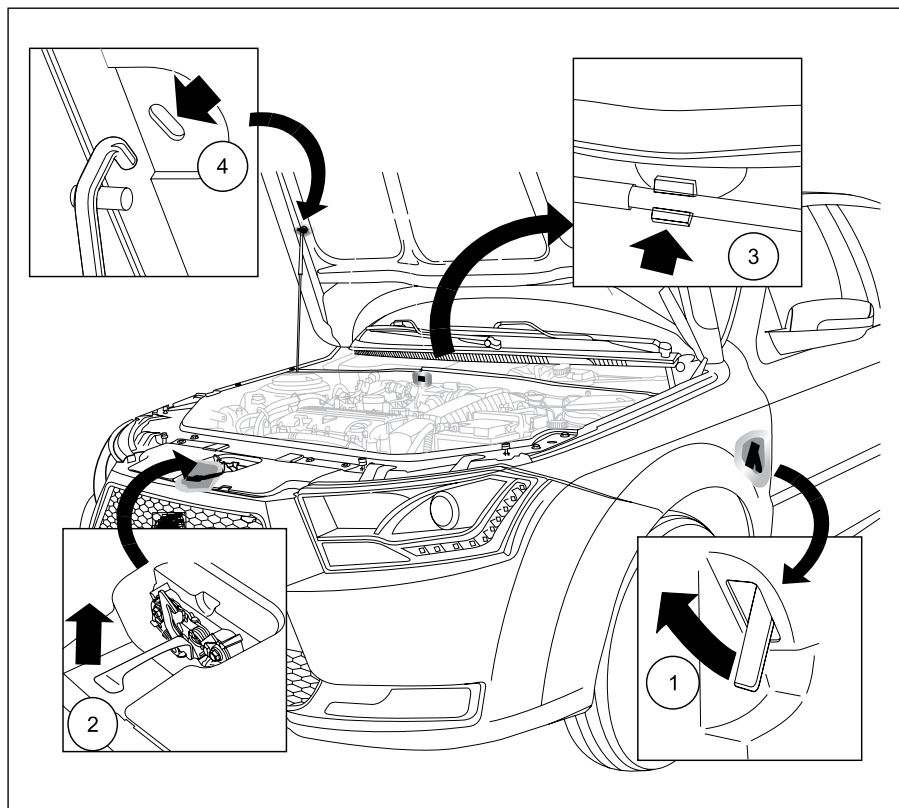

Opening the hood

1. Pull the release hook of hood from driver's side within the vehicles, then the hood will slowly com up a bit.
2. pull up the safety lever of hood and open the hood.
3. Put out the leaning rode from its part.
4. Put the leaning rode on its appropriate hole.

Closing the hood

Pull down the leaning rode then the hood, then release it from 30cm distance. Make sure that the hood is closed appropriately by pulling up its front part a little. The hood shall be fixed appropriately.

Gas jack*

If you need to install a gas jack in your vehicle, you need not to use the support rod in the engine to keep engine hood open. After opening the engine hood, Pull it up, It will be opened upwards on its own when the hood is in half way.

To close the engine hood Lower it and then release it while there is a distance of approximately 30 centimeter between the hood and the lowest point.

* If your vehicle is equipped

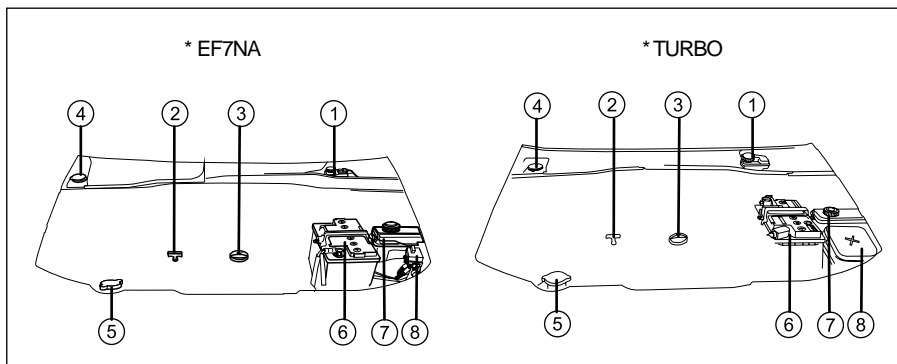

Guide of the hood

- 1.Engine oil tank
- 2.Measuring rode of engine oil
- 3.Engine oil cover
- 4.Glass washer tank
- 5.Radiator cap
- 6.Battery
- 7.Hydraulic steering wheel tank
- 8.Hood's fuse box
- 9-Fuse box

4



WARNING

- At the time of replacing engine's oil, always keep eyes not to leak oil on other engine parts because of blaze danger.
- Never forget covers fastening, because leakage of oil on other parts is highly flammable.
- Display will indicate the oil level when it is less than the minimum level, and extra levels are not being displayed.
- Stand away from the electrical fan of cooler even when you powered off the engine, because it will keep rotating from several seconds.
- Permanent contact with engine oil may result in skins diseases including inflammation and skin cancer. Wash your skin carefully in case of any contact with above materials.



WARNING

- Always keep eyes on the level of engine oil if your vehicle is running at high speed with most of the times.
- Any sudden reduction in vehicle's liquid or unusual erosion of tires shall be immediately reported by the authorized workshops.

ENGINE COMPARTMENT

4

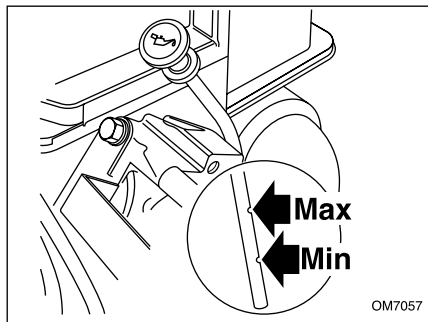

Checking up the engine oil's level

check up the engine oil every week and in case of using the vehicle for long hours. Analyze the engine oil when the engine is ward and the vehicle is parked in flat place

Manner of monitoring the engine oil level

Park the vehicle in a flat place. Warm up the engine, then power off the engine and measure the engine oil's level after 5 minutes.

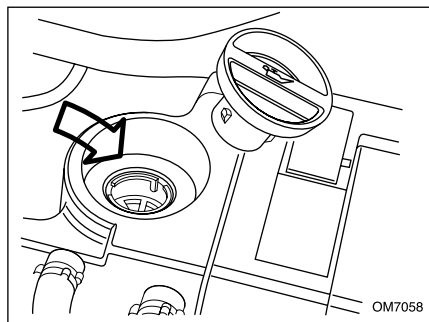

Pouring engine oil

open up the engine oil cover, pour the engine oil three. The engine oil's level shall never exceed from the maximum level showed on the measuring rode.

Refer to the Maintenance Manual guide. in order to get more information in this regard.



WARNING

Never mix the engine oil with other additive, because it may cause severe mechanical losses.



WARNINGS

- The radiator cooler may start rotating anytime, so, take care when working n the hood.
- At the time of replacing engine's oil, always keep eyes not to leak oil on other engine parts because of blaze danger.
- Never forget covers fastening, because leakage of oil on other parts is highly flammable.
- Engine oil replacing: Replacing the engine oil when it is hot, one shall take special case because of danger of blazing due to leakage of oil on other parts.
- Never power on the engine in roofed areas because of existence of toxic gases there.

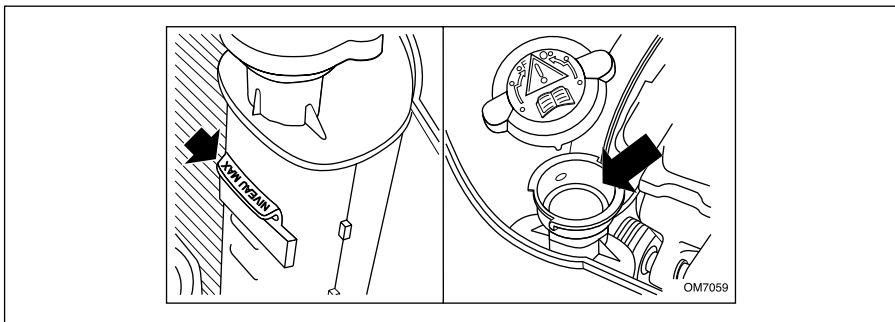

Coolant liquid analysis

The coolant shall be checked up weekly when the vehicle is parked in a flat ground and this system is cool. The coolant shall be between min and max marks inserted on the wall of radiator.

Filling up the radiator

Wait 15 minutes if the engine is hot until its temperature comes less than 100 degree centigrade, then open up its cap by means of a cloth and slowly open it.

Note: if this filling needs more than 1 liter, it is unusual and you shall refer to authorized workshop. Always make sure that the radiator cap is fixed up to its second step.

You can make use of pure water to fill the radiator in emergencies when determined anti-freezing is not available but remind

that this action will decrease the anti-freezing index of the radiator.

Always use the antifreeze with an advised formula and with the approved brands of ISACO.

Note: drainage and filling up the coolant is a maintenance service which needs enough knowledge and shall be done by skilled experts and by authorized dealer of IKCO.

Engine coolant will resist against freezing up to -30 degree centigrade.

Anti-freezing

Anti-freezing includes anti-erosion materials. Not only during winter, but during all seasons, the proportion of water to anti-freezing liquid shall be between 40 to 50 percent.

In order to make sure of the anti-erosion

index of the liquid, the anti-erosion shall be monitored and replaced by IRAN KHODRO authorized workshops.



CAUTION

In case of dismantling any parts of coolant system (except radiator), the set up actions shall be against made by the authorized workshops.

4



WARNING

- The anti-freezing liquid is toxic and its drinking is fatal. Always keep it in its special package away from reach of children. In case of its drinking, immediately refer to a clinic and avoid its contact with your eyes, skins and body.
- Never open the radiator cap up to passing one hour of engine's powering off.

ENGINE COMPARTMENT

Brake

This vehicle is equipped with four-wheel disk brakes system. Front wheel are equipped with coolant disk brakes and back wheel with filled disk brakes. Brake booster is two-circuit hydraulic and will adjust pedal force when the vehicle is running to increase speed.

4

Brake oil

The brake oil may decrease due to erosion of brakes. In case of considerable brake oil shortage, you shall refer to authorized workshop.

Brake oils shall be replaced completely every two years.

In moist climates, the brake oil shall be replaced every 20000 kilometers.

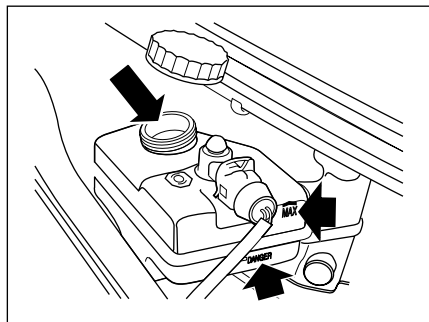

Checking up brake oil

In order to prevent dust going into the tank, first clean the door then open it up, then fill the tank up to MAX point.

Never allowed the brake oil to be less than MIN point, only make use of fresh oils in sealed cans and make sure the reliability of its brand because bad oils will have severely damaging impacts on the brake system.

Never pour oil more than MAX point in the tank.

Only make use of standards and reliable brake oils and packages approved by ISACO.



WARNING

- The brake oil are highly toxic and shall be kept in sealed cans away from reach of children. In case of eating, immediately refer to a clinic.
- Avoid contacting brake oil with your skin and eyes, if so, immediately wash it and refer to a clinic.
- Keep eyes to prevent pouring brake oil on the hot engine, it is highly flammable.
- Take care not to power off the engine in high slopes.



CAUTION

Brake oil will damage the painted surfaces, if so, first clean it with a cloth, then wash it with special shampoos and water.

Hydraulic steering wheel

In case of appropriate functioning, the hydraulic steering wheel will not need or a bit amount of hydraulic oil. Unusual shortage of oil shall be referred to workshop. If the oil is less than the pointed amount, first fill it then start the engine.

In case of oil shortage, never start the engine because the hydraulic equipment will be damaged. If you saw the oil leakage is very slow, you will be able to fill it and go to a workshop.

Consider the oil level every week in this time, power off the engine and allow it to get cooled and front wheel shall be in straight direction.

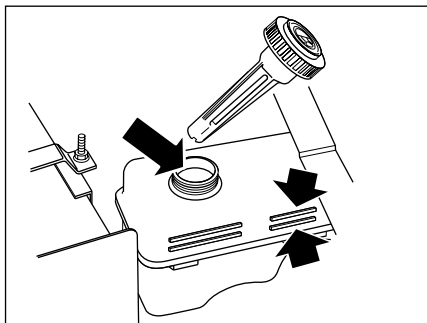
**Checking up the hydraulic oil level**

Clean the cap then release it slowly, and clean its rode with a clean cloth. Then put it and again release it to consider the oil level.

If it is less than pointed amount, fill it and close the cap.

Never pour extra oil in the tank.

Use only hydraulic steering wheel oil and brands approved by ISACO.

In case of contacting hydraulic oil with skin or eyes, immediately wash the location but take care because it is highly flammable.

**WARNING**

Hydraulic oil is severely toxic, so keep it in sealed cans away from reach of children. If so, immediately refer to a clinic.

**CAUTION**

Hydraulic oil will damage the painted surfaces, if so, first clean it with a cloth, then wash it with special shampoos and water.

ENGINE COMPARTMENT

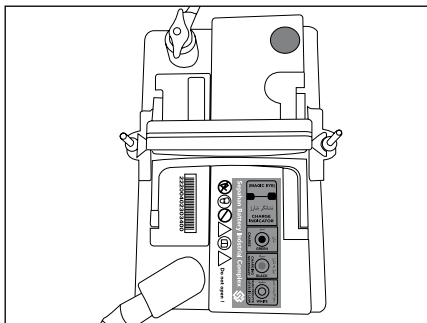

4

LMF & sealed Battery Sealed Maintenance Free

Your vehicle is equipped with a SMF which does not need special cares.



WARNINGS

- The existing hydrogen in the battery is highly flammable.
- Never keep used batteries at home and get it to special workshops.
- In case the battery voltage is less than 10.5 volts, it shall be replaced.
- In case the battery voltage is between 10.5 to 12.4 volts, it shall be recharged.
- Avoid keeping the electric tools ON, when the engine is powered off.

In case of voltage shortage, pay attention to the following tips:

1. Check the alternator belt to be tight enough and check its erosion issues.
2. Wires, ignition wire failures, with appropriate diagonal position.
3. Avoid unnecessary starts in -18 degree centigrade.

Battery's common issues:

- Electrolytes shortage which consists 50% of errors due to heat and over charge. (in case of SMF battery)
- Keeping the lamps turned on which may cause discharge
- Incompatibility of replaced battery with the initial one.
- Alternator belt failures
- Battery terminals loosening
- Making use of urban water instead of distilled water.
- Corrosion
- Freezing



WARNINGS

The battery acid is highly toxic and corrosive, pay attention to the following tips in case of its leakage:

In case of pouring on clothes, immediately take off clothes and wash it, then refer to a clinic.

In case of its contact with eyes, immediately wash it then refer to the physician.

Negligence in medical actions may be result in death.

The battery under charges will release hydrogen explosive gas, hence, put away ignition and fire from around it.

Put out all our jewelry when working in the hood in order to avoid firing and blazing. Never allow contact of battery terminals with metal tools.



CAUTIONS

In case of resting for more than 6 days, the vehicle shall be started and kept powered on for one hour.

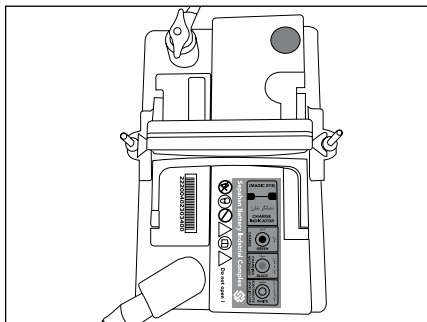

Dismantling battery

First turn off the alarm system and make sure that the switch is off, then release negative terminal (-) and then positive terminal (+), if you wanted to install it again, first positive and then negative terminals shall be installed.

Avoid contacting battery terminals with metal body of the vehicle. To dismantle the battery, first open up its hook then release the battery, to install it again, first close the hooks and clamps, then fix the battery.

Battery replacing

Always make use of original batteries whose type and size are appropriate. Other types may have other details which may not be compatible with your vehicle and cause firing.



CAUTIONS

- Never charge the battery when it is installed on your vehicle because of electric failures.
- The level of battery water and acid shall be checked up each month and filled if necessary.



WARNINGS

Never charge the batteries which may be frozen. Put away fire and ignition from around the battery when it is charging, because of hydrogen gas. After charging the battery and before its installing, wait for one hour so as to allow flammable gases to be released.

ENGINE COMPARTMENT

4

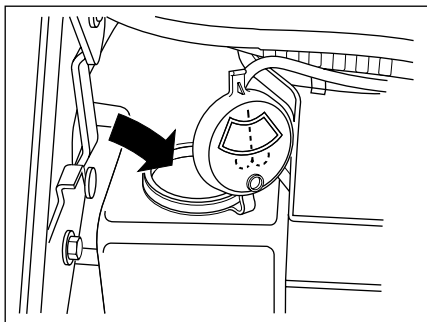

Filling glass washer tank

Check up the level of glass washer tank level weekly. Fill the tank with a combination of water and a reliable washer to ensure its cleaning factor. First mix the water and a washer then pour it into the tank. Always observe the tips inserted on the washer.



CAUTION

- Never make use of a combination of water and anti-freezing liquid because it will damage the color of vehicle.
- Never contact high-pressure water tools in car wash workshops with the locks because of erosion considerations.
- Make sure that the wipers are not frozen in cold climate due to danger of motor warm up.
- When you feel the wipers function decreased, please replace them with new ones. Approximately every year.

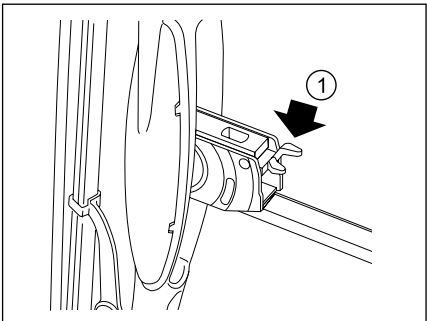

Releasing the snow wipers

Pull up the snow arms and rotate it up to 90 degree.

1. Press down its hook to release the wiper.

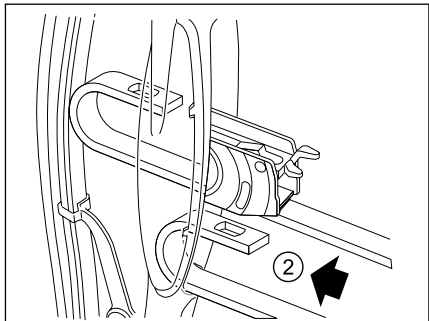

2. press the snow wipers inside in order to release it from the arm them easily open it.

Installing the snow wipers

Replace the snow wipers one by one, so you can see the other one and make a pattern for its installation

Grease, silicon adhesives and oil combinations will damage the performance of snow wipers. Wash the snow wipers with warm water and soap and always check them up.

WASHING AND CAR CARE

Cleaning the vehicle's body

Pay attention to the following tips in order to keep the color's quality:

- Never use of hot water to wash your car
- Make use of damp cloth to clean the dust and fogs from the body.
- Never use cloth washing powder or dish washing liquid to clean your car.
- Never wash the car on direct sunlight in hot climates.
- Never pour direct water to door locks, rubbers and brakes equipment when washing your car.
- Never put footrests on the vehicle's body to wash or dry it.
- Drying footrests on the vehicle's body will damage the color of vehicle.
- Make use of water to clean all dust first, then try to clean it with special washers is order to avoid crashing the color of your vehicles, after cleaning clearly, try to dry the body with a special cloth.

Cleaning beneath the vehicle's body

Try to periodically clean the beneath of vehicle's body especially in winters and specially beneath the tires.

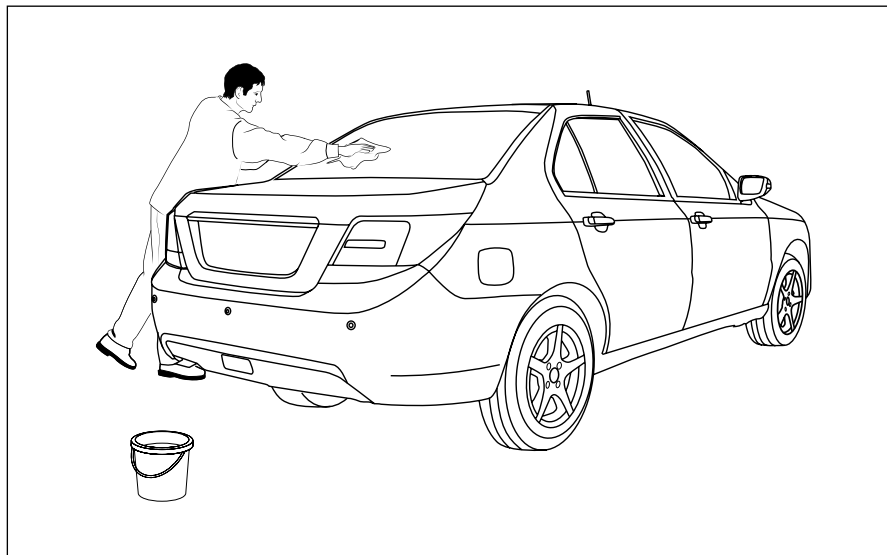

Try to make use of following materials to clean the vehicle's body

- Automobile shampoo
- Shining wax
- Tar spot cleaner
- Glass washer
- Rubber sealing protective
- Rings and aluminum rings cleaner



CAUTION

High pressure of water will inflict damages on rubber tools, hence; never pour water with a high pressure on sensitive places.

Vehicle equipment maintenance

Clean the dusts before cleaning inside of the vehicle.

Plastics parts:

First clean these parts with special cleaners then wash them with a damp cloth. Never shine the dashboard because of safety considerations due to light reflection.

Floor mat

You can make use of home cleaners like carpet shampoo. Try to dry them in shadow to avoid damaging their color.

Hands-free mobile microphone and lever of cruise control *

It is enough to clean it with a dry cloth. Never use hard materials to clean them.



CAUTION

- Installation of extra equipment

Only make use of standard and determined equipment which are compatible with your vehicle in order to avoid decreasing the safety of vehicle.

- Electric and electrical equipment

Any modification on vehicle's electric circuit shall be performed only by authorized workshops because only one false connection may result in sever electrical failures or it tools attached to it. When you are trying to install different electric equipment, make sure that it is protected by a fuse, then make sure appropriate place of fuse and its voltage.

*if installed on your vehicle

WASHING AND CAR CARE

Cleaning tar spots

Make use of alcohol to clear the tar spots on the body. Then wash the place clearly with water and soap in order to eliminate the alcohol material.

Protection of vehicle's body

Always analyze the body's color after washing

Try to repair the crashed parts of the color with a special paint color. Try to paint the vehicle in two steps, and this action shall be done before waxing and polishing the body. Repairing big areas of color damage shall be done according to the manufacturer's manual, Or, the guarantee of the vehicle will be canceled, you can also call authorized workshops to make sure of it.

Polishing the body color

Sometimes, the following polishes are to be used for the vehicle's body:

- Corrosive smooth spots to clear the spots on the body without any damage to the color
- Filler materials to eliminate or restore the

crashes on the body

- A wax to create protective cover between the color and external materials.

Snow wipers

Try to wash the wipers with warm water and soap. Never use white alcohol or gasoline cleaners.

Windows and mirrors

Try to clean the windows and glasses with washers.

Windshield:

Always clean the windshield especially after car wash and before installing new snow wipers.

Back windows:

Try to clean its internal parts with cloths smoothly so as not damage heater elements.

Making use of corrosive washers will damage the heater elements.

Mirrors:

Wash the mirrors with water and soap.

Make use of plastic tools to eliminate ice.

Notice:

Never make use of corrosive washers and/or metal tools.

Cleaning Internal set of the vehicle

Seats:

Make use of standard materials to clean the seats.

Dashboard:

Dashboard is resistant against sunlight, heat and cold, so try not to use covers on it.

Make use of standards washers to clean the dashboard.

Qualitative recommendations in car wash process

- 1.It is advised that you wash your car every week in normal climate conditions.
- 2.Try to wash your vehicle in shadow.
- 3.Pay attention to take action for car wash thirty minutes after powering off the engine.
- 4.Never make use of hard or blading objects or tools in car wash because these will damage on the body and the color. Also never make use of hot water for washing the vehicle. Just warm water is enough. Then after drying the vehicle, try to make use of standards polishes and shiners for your vehicle.
- 5.Never force on the foot place or the car body when washing or drying the vehicle. You can also make use of cotton clothes for drying the body.
- 6.Try to wash first the tires, because the brake dusts are so corrosive and their remaining on the washing cloth will damage the vehicle's color. Also in case of using aluminum rings and metal plates, You shall make use of a soft and clean cloth soaked in a mix of water and

soap. This is to be mentioned that the rings surfaces are so sensitive just like the vehicle body, so severe chemical will damage on them. Also making use of detergent and corrosive materials will crash them; shiners are also used to shine them not washing them.

7. Be more careful when washing with high-pressure water(Consider the water pressure and temperature). There should be a distance of at least 30cm, between the Nozzle of water and the car body. Don't use the above method of washing for washing of painted bumpers, damaged sections and lamps. Use your hand to clean above areas . Also don't keep the nozzle on a surface for a long time. Take more care of the seams areas between the doors and around the glass while washing with High pressure water. Avoid of water spray by the nozzle directly on the lock.
8. Characteristics of appropriate washers to wash the vehicle: Its PH shall be 7 to 9.

Try to make use of high quality lubricants to protect the shiny surfaces from scratches. It is advised to make use of liquid cleaners.

Try not to make use of cleaners which remain some spots on the vehicle after its drying.

Try to make use of shiners in order to protect the shininess and rapid dryness.

9. Rotating brushes used in some car wash workshops are not advised for washing the vehicle with metallic colors.

10. In case of seeing any spot including birds wastes and trees gums, it is advised to wash them immediately due to their penetration potential to the vehicle's color.

11. Dry the leaked water to the boot and internal parts of the vehicle after doing the car wash.

12- If you use high pressure nozzles; avoid spraying the water directly to the camera, sensors and areas around them and also, the sunroof sealing tape *.

High pressure water can cause damage to the assemblies or sealing tapes.

WASHING AND CAR CARE

Natural leather maintenance *

Natural leathers need a special care for the maintenance of beauties and stability. Try to dry them in case of pouring any spot of food or liquids. Never make use of blowers to dry the leathers. Never make use of dish washing liquids, detergents, and soap, solvents, polish and corrosive cleaners to wash the vehicle's leather.

You shall only make use of special leather cleaners; these materials will clean the spots without remaining any spot on the leather.

You can test the performance of cleaners in small areas out of vision, and then use them for other leather parts.

Cleaning the leather surface shall be done every several months. First clean the dusts from the surface of leather. Then use cleaners from the surface in a rotating move of hands.

Smelling the leathers surface is natural in first months of buying the vehicle. In case of parking the vehicle in a private and safe parking, you can put one of the windows a bit open.

Avoid direct sunlight on leather parts.

Never make use of any wax for leather parts, because they will result in absorbing dust on the surface.

The leather cover shall be cleaned by a damp cloth and a cotton cloth soaked in shampoo is very effective.

You can refer to IRAN KHODRO authorized workshops in order to restore the leather surfaces with small corrosions.

Maintenance of clothes used in internal decorations

These kinds of clothes just like the other ones need special care for maintenance and stability; so, you shall clean any spots including those of foods, drinks, alcohols with a sponge and shampoo from the clothes. Never make use of dish washing liquids or polishes especially corrosive ones on the clothes.



CAUTION

Try to clean any kind of spot(s) from the clothes by carpet shampoo and sponge.

5 TECHNICAL SERVICES

WHEELS REPLACING	118-121
AUTO TOWING	122-123
BATTERY SERVICE AND MAINTENANCE	124-126
FUSES	127-132
LAMPS REPLACING	133-143

*If equipped

CHANGING WHEELS

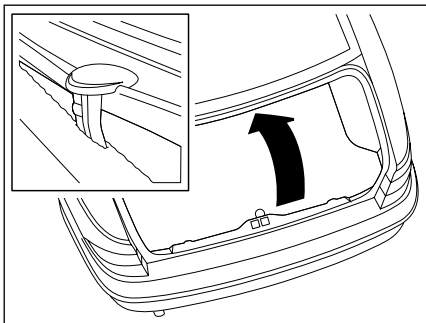

5

Spare tire and its tools

Pull up the floor mat of hood and push the related clamp in order to tight to the special hole on the edge of mirror.



WARNING

- The jack shall be used for replacing the spare tire, never make use of it for repairs and accessing some parts.
- In case of taking too long, refer to IRAN KHODRO authorized workshops in order for inspecting the spare tire, then to be sure of its performance.

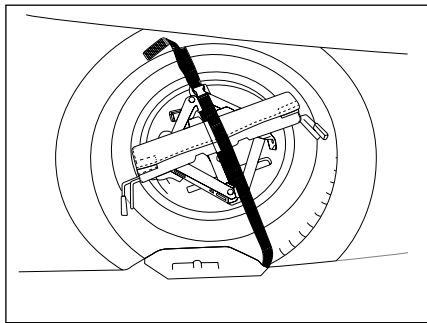

Spare tire

Open up the fastening belt of spare tire and warning triangle, put up the tools box, and release the spare tire.

Warning triangle

When stopping due to failure or any emergency, the warning triangle shall be installed at 50 to 100 meters behind the vehicle. If an embossed area or a hill prevents behind driver's vision, put it in another appropriate place.

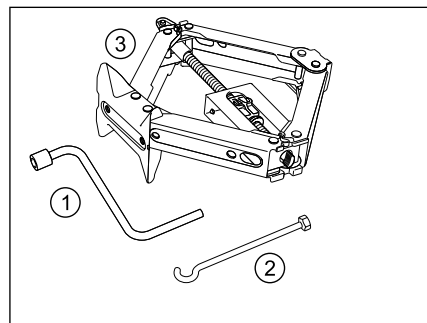

Tools:

1. Wheel wrench
2. Jack wrench
3. Jack

The tools box prevents the boot mat to sink. Fix the sealing belt tightly in order to prevent tools from moving. For some models, there designed special other tools herein tools box.



WARNING

Always select a far place to replace the wheel in order for safety consideration, far the passengers away from vehicle and start repairing.

Place of jack beneath the vehicle

Install the jack in one of the four points showed in the image near to the wheel to be replaced.

- Make sure that the jack is placed in a flat horizontal manner.
- Never make use of jack when any passenger is seat on the vehicle.
- Make sure that the front wheels are straight, then pull up the handbrake and put the gear into 1.



WARNING

Never repair the beneath the vehicle when it is pulled up ONLY by the jack. The jack is designed just for replacing a flat tire.

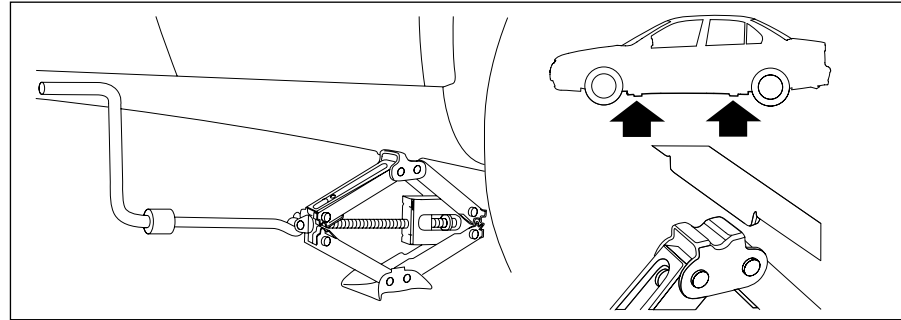

Putting the jack beneath the vehicle

1. Loose tire screws with abovementioned wrench.
2. Install the wheel wrench to the jack wrench and put its tail hook on the jack hole, rotate the wrench clockwise to pull up the vehicle.
3. Pull up the vehicle from earth until it goes up enough.
4. Loose other screws and put out the wheel.

Insert the spare wheel.

- Fasten all four screws.

- Tight the screws in a cross manner.
- Put the tools into their box and into their appropriate place in the boot. Then fasten its belt.
- Repair the flat tire as soon as possible and put it into its appropriate place.

CHANGING WHEELS

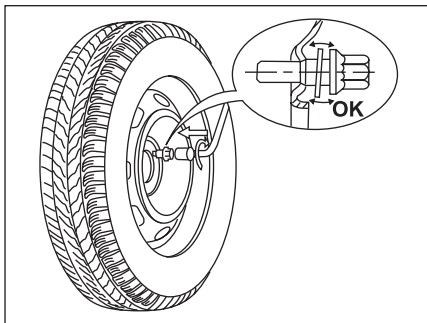

5

Replacing of spare wheel

Your vehicle is fitted with a steel spare wheel.

Care should be taken for the screw washer not to contact with the string at the time of inserting it. Spare wheel is tightened on the side of cone-shaped screws.

Releasing aluminum sport ring *

The steps of replacing aluminum sport ring is just like metal ring, just the step of releasing hubcap shall be omitted.

*if installed on your vehicle



WARNINGS

After replacing the wheel, always check up the air pressure and make sure the good fastening of screws.

- Replace the flat tire as soon as possible, the flat tire shall be surely analyzed by an expert.
- Always park your vehicle is a flat surface not in slippery surfaces, and make use of a jack holder. Turn on the flashers. Pull up the handbrake and never put the gear in N mode. Try to far other passengers away from the vehicle then do your operation.

CAUTION

In the vehicles equipped with aluminum rings:

- The fifth tire is deemed as a spare tire which shall be used in replace of flat tires.
- Therefore, the non-compliance of the tire manufacturer with that of spare tire design with other aluminum rims tire are not prohibited.

Wheel chains

The wheel chain can effect driver control onvehicle. When using a wheel chain, pay attention to the following points:

- Do not drive at speeds more than 50 km/h. If the speed of lower than 50 km/h has been denoted by the wheel chain manufacturer, consider the lower speed of driving as your criteria.
- Take caution at driving and drive with lowest speed as far as possible, while you're passing on obstacles, hurdles, holes etc.
- Avoid equipping the spare tire with wheel chain; Because this can lead to damage to the spare tire as well as the vehicle.
- Use of the wheel chain for roads free of snow and ice, will cause damage to the tire and wheel chains.

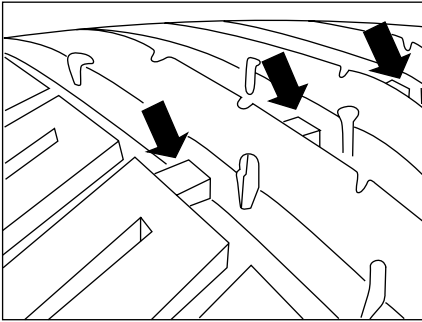

Tires erosion indicator

The tires prepared for the vehicle are equipped with some erosion indicators. When the tires are worn way, these indicator crowns will remain only in 1.6 mm and this shows that the tires may be replaced.

Tires air pressure

Tires air shall be adjusted every month when the tires are cool. Tires low air pressure will make it hot and reduce the useful life of tires. High air pressure will also have negative impacts on the vehicle's convenience.



WARNINGS

Driving with the tires in which the air pressure has been reduced more than 20% of what has been recommended will cause the increase of fuel consumption and effects the vehicle dynamic and brings about the unexpected functional reduction of the vehicle.

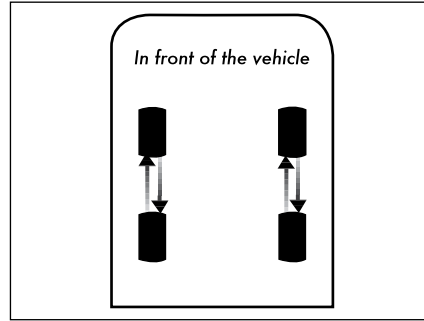

Tires size

The size of tires are inserted in a phrase on the wall of tire like this 185/65 R15, 185 is the width of tire in mm, 65 is the ratio of heights to width in mm, R shows the design of radial and 15 shows the ring diagonal characteristic.

Tires rotating in the vehicle

In front differential vehicles, the erosion of front tires is more than back tires due to existence of brake force, running force, and steering wheel forces. Hence, the tires shall be replacing every 10000 km based on above plan.

Tires maintenance

Always drive your vehicle based on details of your tires. And always analyze their crown and side walls in order to check up any possible failure.

Getting flat

The flat tire shall be immediately released from the vehicle and put under consideration, in order to prevent more possible damages to the tires, its repair shall be done by skilled experts. The repairs shall be done only by experts who are responsible for its quality.



WARNINGS

- Flat or worn out tires are so dangerous so avoid driving with such tires.
- Always make use of radial tires with the same design, and avoid using cross designed tires.
- Never drive your vehicle with flat or work out tires which air is not adjusted. Flat tires will have erosion soon, which will cause fuel increase and reduction of steering wheel functioning.
- Driving with the tires in which the air pressure has been reduced more than 20% of what has been recommended in off roads, may cause damage and deformation of the rings.
- It will also increase the risk of attaching sands between rings and tires which brings about immediate depletion of tires result in accidents.

VEHICLE TRANSPORT

Auto towing

Towing vehicle with manual gearbox

Put the gear in N mode and turn on flashers.

Drive with care and avoid violating speed limitation for towing, i.e. 50 km/h

Try to keep the towing belt as tight with soft brakes. This will prevent impacting the belt and its break.

Use recommendations of skills persons for towing.

5

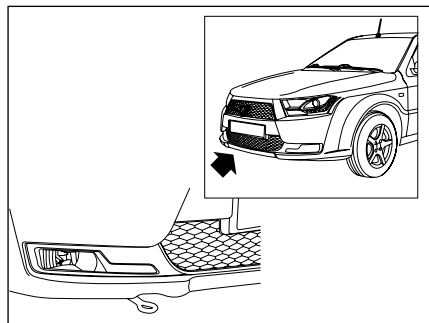

Front loop of the towing

This loop is designed beneath the front bumper and shall be used only to tow the vehicle on four wheels.

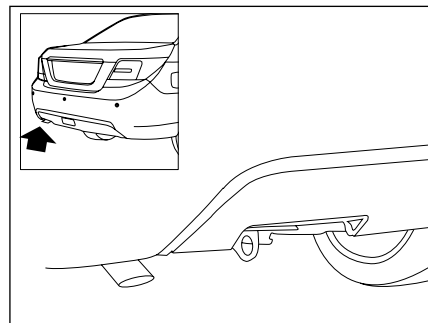

Back loop of the towing

The back loop is just used for towing a vehicle with the same weight or lighter. Never make use of this loop to tow two vehicles on two wheels.



CAUTION

Avoid removing the ignition switch or putting it in OFF mode when towing a vehicle on four wheels, because this will result in locking of steering wheel. It is advised to put the switch in A mode.



WARNING

It is advised to make use of a hard rode and fixed style for towing. In case of using rode or cable, the towing vehicle shall be able to brake.

Avoid sudden brakes for safety considerations.

It is advised not to exceed speed from 35 km/h.



WARNING

The tower vehicle shall always be heavier than the other vehicle to be towed.

The vehicle to be towed shall not have any passenger.

You shall put more force on brake pedal when the engine is powered off.

Never tow a vehicle which is not moving at all.

Auto towing with a truck

Transporting with a truck is advised to avoid any kind of accident and sudden crashes.

Towing from back

Avoid towing the car from front wheels if possible, if so, drive so slowly in short distances. In this situation, the steering wheel shall be locked on straight direction. You can also make use of holders to lock the steering wheel.

Towing from front

The steering wheel shall be locked on straight direction. You can also make use of holders to lock the steering wheel.



CAUTION

When you're towing from front wheels and running on back wheels, make sure that the handbrake is released, because of its functioning on back wheels.

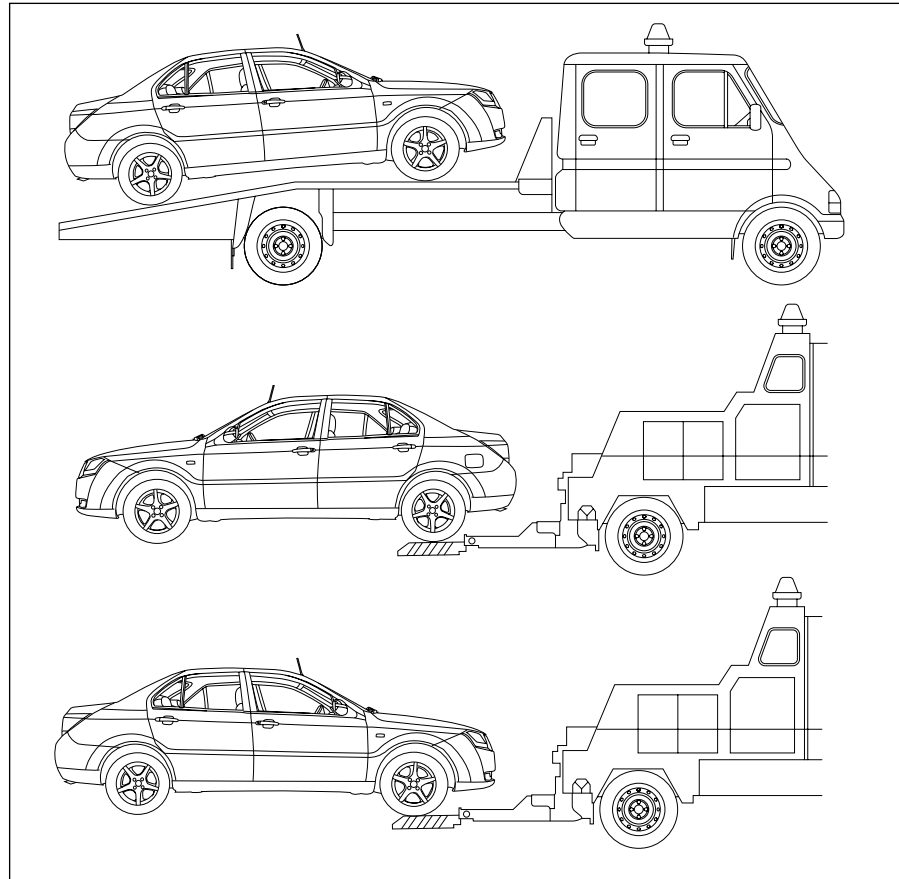

SERVICE AND MAINTENANCE OF BATTERIES

Safety recommendations for Battery

- Never impact battery terminals.
 - Avoid short circuit of positive and negative terminals.
 - Never overcharge the battery, cause this will reduce its useful life and efficiency.
 - Make sure that the screws of battery are opened, cause gases compression will be result in explosion.
 - The battery shall be fastened in its appropriate place, cause sudden crashes may result in severe damages.
 - Avoid keeping the battery in its discharge mode, cause sulfate failure of battery plates.
 - Creating ignition and nearing fire to the battery will result in explosion due to existence of hydrogen and oxygen, so avoid such materials to be near battery.
 - It is advised not to add any additives to the battery including battery pill, battery vitamin, and alike.
- In order for short circuit considerations, first plug in positive and then negative terminal of battery when you are installing battery on the vehicle, and vice versa when you're releasing the battery from the vehicle.
 - Make sure the appropriate functioning of alternator and regulator.
 - Avoid adding extra electrical equipment without taking into consideration the battery capacity.
 - The battery will not be subject to conditions of guarantee if:
Inappropriate use of battery
Inappropriate service and maintenance
Long-time vehicle resting
at discretion of technical experts.

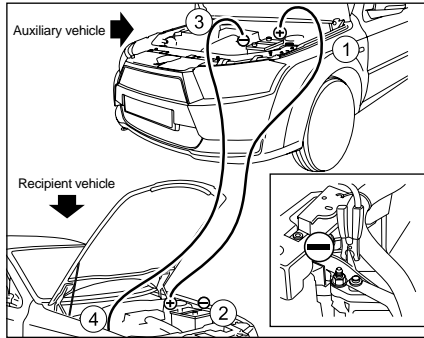

fig (1)

Emergency battery charging

In case of failure in powering on the engine due to battery issues, take action in following manner:

A) Battery-to-battery charging (auxiliary vehicle)

1. Check to ensure both vehicles use 12v battery systems, OR it will cause severe damages to electric system.
2. Make close both vehicles in a way that no connection is made between them.

Short circuit due to negligence of distance between two vehicles will result in severe damages.

3. Turn off all electric components including audio system, etc. turn off the engine of auxiliary vehicle, check if both vehicles are in N gear, pull up both handbrakes, if not, electric components will damage and this will not subject to guarantee.

4. Open door of both vehicles and identify positive and negative battery terminals. You can make use of a lamp if you are in a dark place.

5. a battery-to-battery charger cable is needed in this step, this is often a black and red cable. As according to image 1, plug the positive terminal of auxiliary battery to the positive terminal of empty battery.

6. Plug negative terminal of auxiliary battery to a metal part of other vehicle which is not painted. Make sure that the connections are not passing gasoline pipes, brake connection and rotating parts of both engines.

7. Now, power on the auxiliary vehicles and wait a minute until normal rpm.

8. Now, power on receiver vehicle and wait a minutes until normal rpm.

9. Then plug our the cable as shown in figure 2.

SERVICE AND MAINTENANCE OF BATTERIES

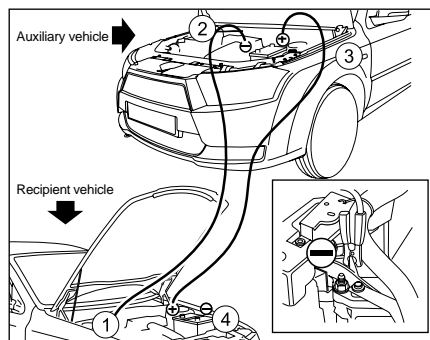

fig (2)

5

B) Charging battery with a charger

It is needed to release the vehicle's battery, and take action as following manner:

- 1.First, plug out the negative terminal.
- 2.Then plug out positive terminal.
- 3.Now release the battery by means of a handle.
- 4.Deliver the battery to an authorized workshop.

Pay attention to the following tips:

- Pay attention that the terminals and clamps are clean, if not, release them and clean their sulfate materials.

- Never plug out cables when the engine is powered on.
- Never take action to recharge battery if you did not plug out terminals
- Plug out battery terminals when the vehicle is going to rest for a long time, i.e. for a month or more.



CAUTION

Final battery voltage shall be equal to 12v, i.e. 14,10-14.40



CAUTION

- Make sure that the auxiliary battery is compatible with the empty one in respect of its voltage. (12v), and connector cable have supported.
- If you are not using the vehicle for a long time, plug out battery terminals and charge them every 4 weeks.
- Whereas start voltage is 12v, so, making use of a 24 v battery will be severely damaging, so, just use 12v battery.
- The positive terminal (red cable) shall be always plugged to the positive terminal of other battery, in order to prevent alternator damaging, never allow it to function without connecting to the battery.

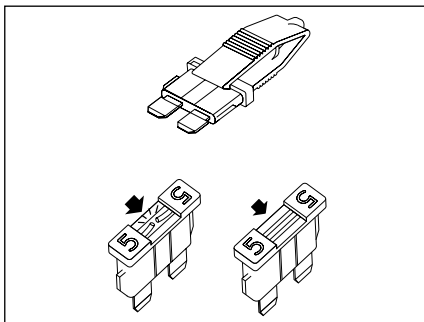

Fuse box

Fuse box is designed in two sections, inside and outside (hood) of the vehicle. The internal one is designed beneath the left side of dashboard, near the battery.

Fuses

The fuses are simple connections which shall cut off the power in necessary cases in order to avoid damaging electric components. In case of malfunctioning of an electric component, its fuse may be out of use.



WARNING

- Test the related fuse and replace it with a new one if necessary. Making use of a fuse with higher voltage may warm up the device and there is a danger of blazing.
- The electric system of your vehicle is only designed for the current electric components installed on your vehicle, hence, avoid installing extra electrical tools and devices, if necessary, you can consult with the skilled experts of workshops.



CAUTION

Any kind of changing and/or modification of power supply system components including fuel parts (ECUU and wiring), fuel circuit, injector, caps and doors is highly forbidden because of possible dangers, unless upon consultation and action of after-sale-services network experts.

FUSES

5

Fuse operation	Fuse ampere	Fuse
Front seat power	20A	F1
Ignition switch 1,2 / Brake switch power / Radio power	10A	F2
Lighter power	20A	F3
feeding after sunroof switch*	10A	F4
Vent fan	30A	F5
Starter	20A	F6
Reserve	10A	F7
CN power / Immobilizer power	5A	F8
Back right indicator light Back rear gear light Left brake light Plate light Right tail light Background light of back glass lifter RN power	15A	F9
Back left indicator light Back right fog light Back left rear gear Right brake light Front and back roof light (door control) Back left tail light Back control unit RN power	15A	F10
Electric trunk actuator Rear electric actuators Electric actuator for petrol Rear door lights and trunk bulbs Front and rear ceiling lights in permanent mode	30A	F11
Reserve	20A	F12
Back windows and mirror heater Back left windows lifter Back rights windows lifter	30A	F13
Radio and radio memory Diagnosis connector power	15A	F14

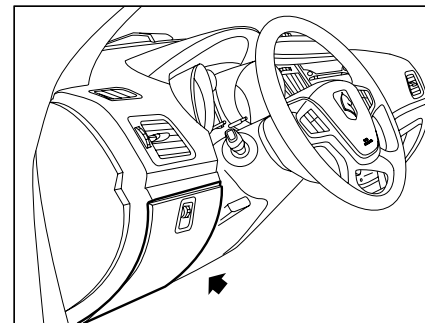

Fuse box CCN

This node is located beneath the air vent and at the left side of the steering wheel.

Fuse operation	Fuse ampere	Fuse
Front dashboard and central glove box lights Map reading, dashboard, make-up mirror and electric mirrors lights CCN power Back windows heater and mirror heater lights Flasher key light Central lock key light Boot opener key light FN front control power ICN power ICN memory power	5A	F15
Diagnosis connector power after switch Ignition switch 2,3 ABS power supply	5A	F16
Air bag	10A	F17

* If your vehicle is equipped

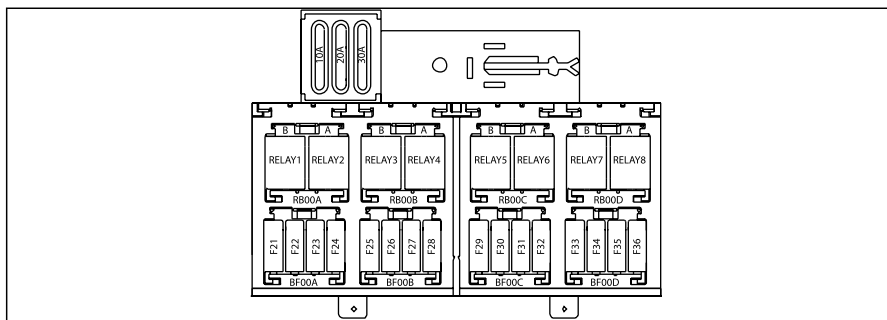

Fuses guide table (cabin)

Fuse No.	Rating	Fuses function
F21	30 A	Electric Seat Supply
F22	10A	Main switch supply (position 2) air bag unit and air conditioning system
F23	10A	Main switch supply (position 1) lighter
F24	10A	Main switch supply - position 1 (motivation of heater relay - Radio, brake, light, front node, central node and instrument panel), Motivation of Glass Heater Relay
F25	10A	Radio permanent supply
F26	20A	Central node supply
F27	20A	Central node supply
F28	30A	Central node supply and motivation of rear door motive relay
F29	30A	Rear Lifting Window
F30	30A	Central node supply (Front lifting window)
F31	30A	Rear window heater
F32	30A	Heater fan supply
F33	30A	Engine ignition
F34	10A	Main switch supply (position 2) immobilizer, diagnostic connector, instrument panel, cooler gas pressure sensor, engine unit
F35	5A	Main switch supply (position 2), Anti-brake system (ABS)
F36	10A	Immobilizer permanent supply, diagnostic connector, instrument panel

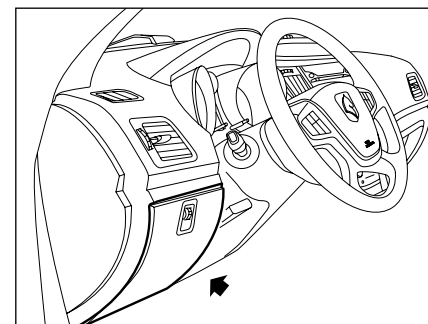

FUSE BOX AND DASHBOARD RELAY*

This node is located beneath the air vent and at the left side of the steering wheel.

Relay No.	Relay Function	Rating - type
RLY1	Electric actuator of left front door.	Contact 2- 30A
RLY2	Trunk Lid Electric Actuator	Contact 1 - 30A
RLY3	Mirrors and rear window heater	Contact 1 - 30A
RLY4	Ventilation Fan Relay	Contact 1 - 30A
RLY5	Rear Lifting Window (Left)	Contact 2 - 30A
RLY6	Rear Lifting Window (Left)	Contact 2 - 30A
RLY7	Rear Lifting Window (Right)	Contact 2 - 30A
RLY8	Rear Lifting Window (Right)	Contact 2 - 30A

* If equipped

FUSES

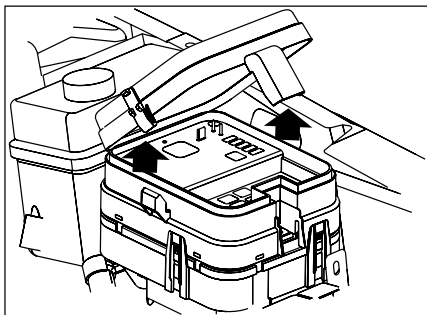

Fuse box and FN node

5

The fuse box and FN node are designed at left side of hood. You shall first release its clamps to access it. Make sure the appropriate fastening when closing it.

The vehicle's owner shall not relocate the fuses. Any issue in this part shall be analyzed by related experts.



WARNING

Your vehicle's electrical system is designed just for the existing selected equipment, hence, never install extra equipment on it, or consult with IRAN KHODRO experts before doing so. Some electrical tools or their manner of installing will have negative impacts on electric control circuits, audio circuits, and battery charging circuits. Installing new electrical equipment shall only be done by skilled experts.

Fuse Operation	Fuse Ampere	Fuse
Snow wiper motor	30A	F1
Cooler compressor Windows washer	15A	F2
Double relay II	30A	F3
Double Relay I	30A	F4
Brake II ABS	30A	F6
Brake I ABS	30A	F7
Fan I	30A	F8
Right mirror heater Front right indicator light Front right windows lifter motor Front right door performance motor Right mirror motor Right folding mirror Front right door light Background light key Door node power supply	20A	F9
Left mirror heater Front left indicator light Front left windows lifter motor Front left door performance motor Left mirror motor Left folding mirror Front left door light Door node power supply	20A	F10
Horn	30A	F11
Door node power supply Alarm power supply	10A 10A	F12
Engine ECU	10A	F14
Front right fog light Front left fog light	15A	F16

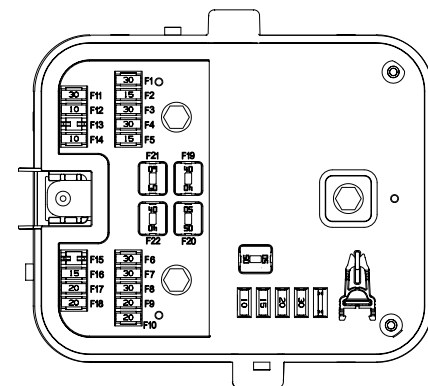

5

Fuse Operation	Fuse Ampere	Fuse
Front left indicator light Left high beam Left tail light Right low beam light	20A	F17
Front right indicator light Right high beam light Right tail light Left low beam light	20A	F18
Central node power supply II	40A	F19
Start power supply	50A	F20
Central node power supply I	60A	F21
Fan II	40A	F22

FUSES

Fuses Guide Table *

Fuse No.	Rating	Fuses function
1	40A	Electric supply for ignition switch
2	30A	Relay switch for fog lamp/horn
3	40A	BCM Inside systems electric connection supply
4	30A	BCM Inside systems electric connection supply
5	40A	Fan (High speed)
6	30A	Fan (Low speed)
7	30A	Brake (ABS)
8	40A	Brake (ABS)
9	-----	-----
10	20A	Front node supply
11	15A	Front node supply
12	30A	Front node supply windshield wiper and relay for windshield washer pump
13	-----	Reserve
14	30A	Double relay supply
15	10A	Fuel pump supply
16	10A	Engine unit supply
17	-----	Reserve
18	-----	Reserve
19	-----	Reserve
20	-----	Reserve

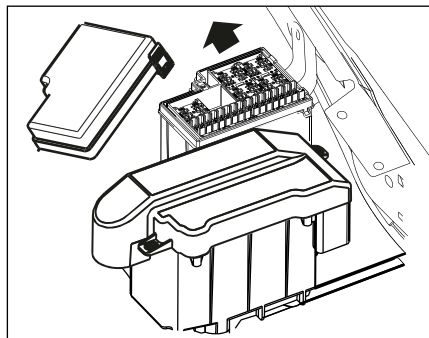

Relays Guide Table *

Relay No.	Relay Function	Rating - type
RLYa	Relayt switch for engine control	30A - 1 Contact
RLYb	Relay switch for fuel pump	30A - 1 Contact
RLY1	Relay switch for fog lamp	30A - 1 Contact
RLY2	Relay switch for horn	30A - 1 Contact
RLY3	Relay switch for windshield wiper	30A - 2 Contact
RLY4	Relay switch for windshield wiper	30A - 2 Contact
RLY5	Relay switch for fan (high speed)	40A - 1 Contact
RLY6	Relay switch for fan (low speed)	30A - 1 Contact
RLY7	Relay for fan	30A - 2 Contact
RLY8	Relay for windshield washer pump	30A - 1 Contact

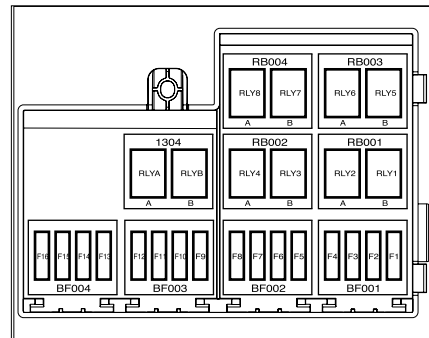

Engine Compartment Fuse box *

Fuse box is in the right part of the engine compartment. To access the fuse located in the engine compartment, unclip the fuse box cover.

Close the fuse box cover carefully when you have finished.

Vehicle owner shall not tamper fuse connection.

Any problem in this part should be checked by authorized experts.

* If installed in your car

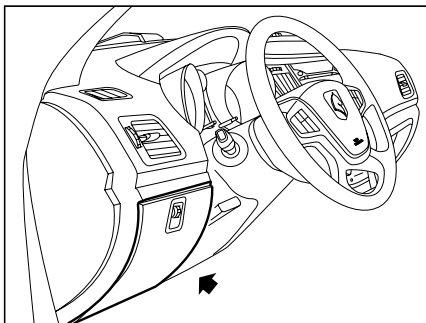

Fuse box and dashboard Relay (Eco-max) *

Place of this fuse box is on the left side of the steering wheel Below the air vent.

Guide table of relays

Relay No.	Relay	Flow ntensity- Type
RLY1	Electric Trigger in the trunk	30A - 2 Contact
RLY2	Rear glass and mirrors heater	30A - 1 Contact
RLY3	Electric Trigger of Heater fan	35A - 1 Contact
RLY4	Left rear glass lifter	30A - 2 Contact
RLY5	Left rear glass lifter	30A - 2 Contact
RLY6	Right rear glass lifter	30A - 2 Contact
RLY7	Right rear glass lifter	30A - 2 Contact
RLY8	Electric trigger of driver's door opener	30A - 2 Contact
RLY9	-----	30A - 2 Contact
RLY10	-----	30A - 2 Contact
RLY11	-----	30A - 2 Contact

* If the Eco-Max system is installed on Dena Plus vehicle.

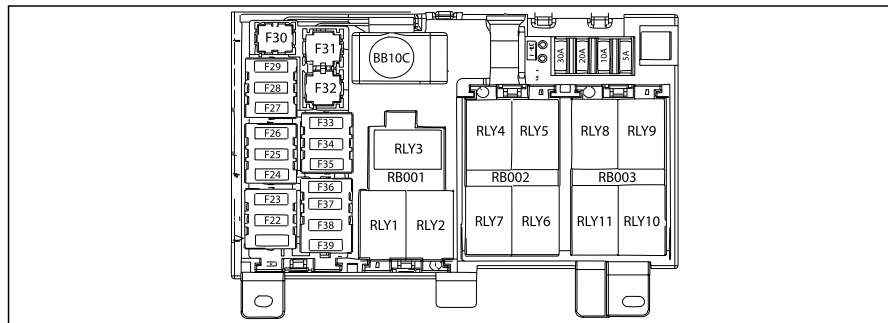

Fuses Guide Table

Fuse No.	Flow Intensity-	Function
F21	RES	-----
F22	RES	-----
F23	RES	-----
F24	RES	-----
F25	30A	Power supply of rear glass lift
F26	10 A	permanent power supply of Radio
F27	20 A	Power supply of central node
F28	20 A	Power supply of central node
F29	30 A	Power supply of central node & Stimulating of boot relays & left front door opener.
F30	RES	*****
F31	30 A	Rear glass heater
F32	40 A	Power supply of heater fan
F33	30 A	Power supply of electric chair
F34	10A	Power supply of main switch - 1st position(Stimulating heater fan and rear glass heater, driver node, Sunroof, instrument panel, Front node)
F35	20 A	Power supply of main switch -1st position(Lighter)
F36	10 A	Power supply of main switch 2nd position(Anti-lock Brake System, mobilizer , instrument panel, Troubleshooting connector, Brake Switch)
F37	5 A	Power supply of main switch 2nd position(Air bag unit)
F38	10 A	Power supply of main switch 2nd position(Central node – Air condition system)
F39	10 A	Power supply of main switch 2nd position(Engine unit , cooler gas pressure sensor)

FUSES

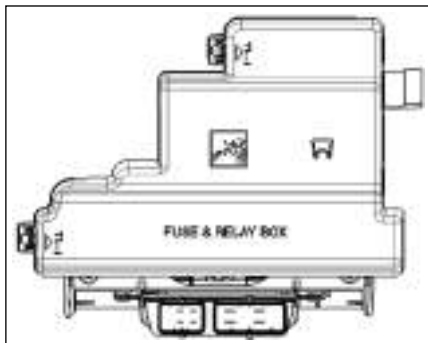

5

Engine fuse box (Eco-max)

The fuse box is located on the right side of the engine compartment.

Release the clips of box door to achieve the fuses and open the door.

Ensure of proper insertion of the box door while you're closing it.

The vehicle owner should not manipulate the fuses or connect and disconnect them.

And connect. Any problems in these areas should be repaired by Authorized experts.

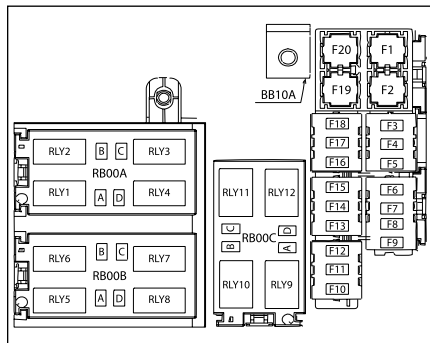

Relay guide table

Relay No.	Relay	Flow ntensity- Type
RLY1	Slow rotation Fan relay	30A - 1 Contact
RLY2	Fast rotation Fan relay	40A - 1 Contact
RLY3	Wiper washer pump relay	30A - 1 Contact
RLY4	Fan relay	30A - 2 Contact
RLY5	Wiper washer relay	30A - 2 Contact
RLY6	Wiper washer relay	30A - 2 Contact
RLY7	Front Fog lamp relay	30A - 1 Contact
RLY8	Horn relay	30A - 1 Contact
RLY9	Fuel pump relay	30A - 1 Contact
RLY10	Engine control relay	30A - 1 Contact
RLY11	Sunroof relay	30A - 2 Contact
RLY12	Day light relay	30A - 1 Contact

Fuses Guide Table

Fuse No.	Flow Intensity	Function
1	30A	Power supply of start
2	40A	Power supply of start switch
3	10A	Front Fog lamp
4	5A	Power supply of day light
5	10A	Permanent power supply of Sunroof
6	10A	Power supply of Engine sensor
7	20A	Power supply of injector, coil
8	5A	Power supply of fan relay stimulator and sunroof relay.
9	10A	Power supply of engine unit
10	10A	Power supply of Fuel pump
11	30A	Main power supply of engine
12	10A	Power supply of instrument panel, Troubleshooting connector, sunroof, alarming
13	30A	Power supply of ABS
14	20A	Power supply of Horn
15	30A	Power supply of front glass lift
16	30A	Power supply of wiper washer and glass washer pump
17	15A	Power supply of front node
18	20A	Power supply of front node
19	40A	Power supply of fans
20	40A	Power supply of ABS

* If the Eco-Max system is installed on Dena Plus vehicle.

CHANGING LAMPS

Lamp	watt	No.
Front high light	H7-55W/12V	1
Front low beam light	H1-55W/12V	2
Meeting light	LED	3
Front indicator light	PY-21W-12V	4
Front fog light	H1-55W-12V	5
Tail light / brake warning light	P-21W/12V LED	6
Back indicator light	PY-21W/12V	7
Rear gear light	P-21W/12V	8
Back fog light	P-21W/12V	9
Above brake warning light	LED	10
Mirror indicator light	LED	11
Boot light	5	12
Make-up mirror light	5W/12V	13
Study lights	5W/12V	14
Door light	LED	15
Plate light	5	16
Dashboard light	5W/12V	17

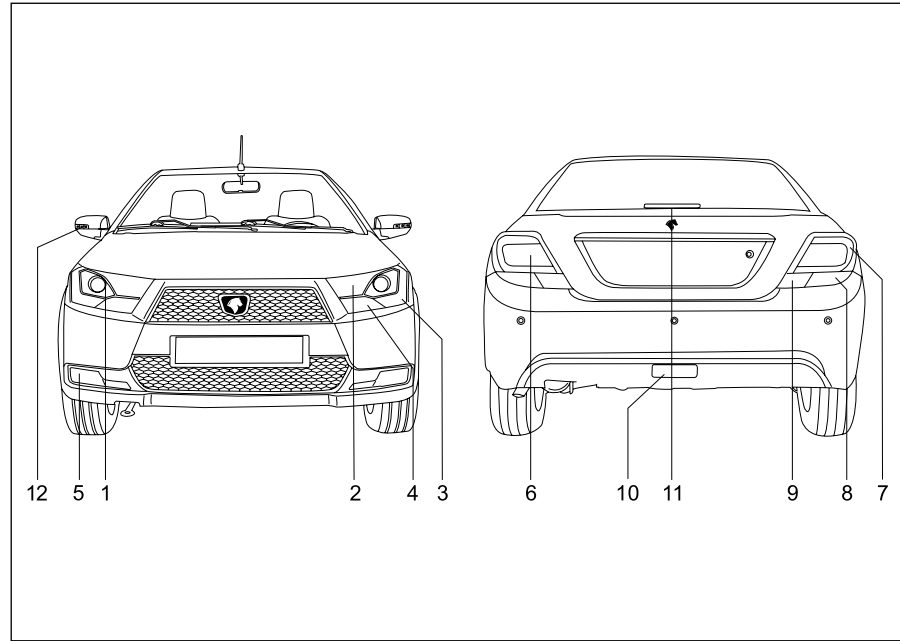

5



WARNING

Check up the external lights operation key before starting to drive.
 When replacing nay of lights, switch it off to avoid short circuit.
 Lamps are vacuum which may be broken at replacing and cause injury.

CHANGING OF LAMPS

Dena⁺

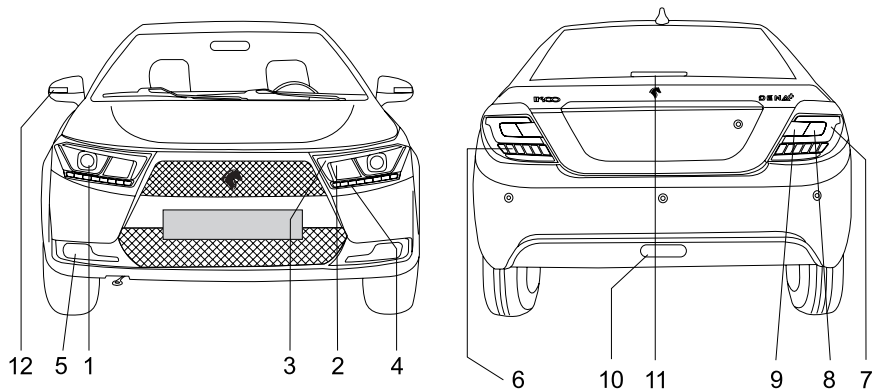

5

Lamp	watt	No.
Front high light	H7-55W/12V	1
Front low beam light	H1-55W/12V	2
Meeting light	LED	3
Front indicator light	PY-21W-12V	4
Front fog light	H1-55W-12V	5
Tail light / brake warning light	P-21W/12V LED	6
situation lamp -rear and braking	LED	7
Back indicator light	PY-21W/12V	8
Rear gear light	P-21W/12V	9
Back fog light	P-21W/12V	10
Above brake warning light	LED	11
Mirror indicator light	LED	12
Boot light	5	13
Make-up mirror light	5W/12V	14
Study lights	5W/12V	15
Door light	LED	16
Plate light	5	17
Dashboard light	5W/12V	18



WARNING

Check up the external lights operation key before starting to drive.
When replacing nay of lights, switch it off to avoid short circuit.
Lamps are vacuum which may be broken at replacing and cause injury.

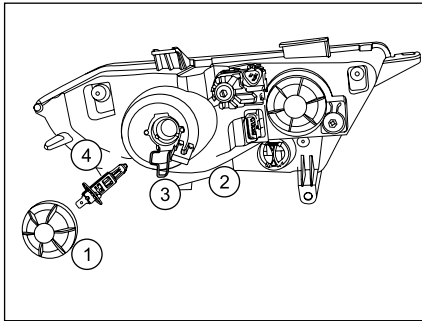

Low beam light

1. Open the cap counterclockwise.
2. Plug out power
3. Release its clamp with a side push
4. Replace the lamp according to baselines
5. Install the clamp appropriately
6. Plug in the power
7. Fix the cap clockwise.

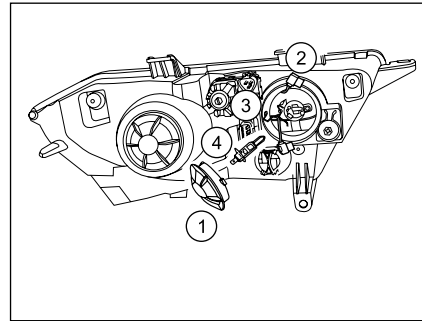

High beam light

1. Open the cap counterclockwise.
2. Plug out power
3. Release its clamp with a side push
4. Replace the lamp according to baselines
5. Install the clamp appropriately
6. Plug in the power
7. Fix the cap clockwise.

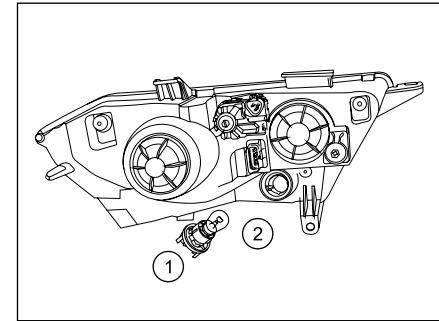

Front indicator light *

1. Open the cap counterclockwise.
2. Release the lamp by pushing and pulling counterclockwise, and replace it using a clean cloth.
3. Fix the cap clockwise.

5



WARNING

Plug out the main power supply before replacing the lamps, then plug it again after replacing the lamp.

* It's replaceable in Dena vehicle only

CHANGING LAMPS

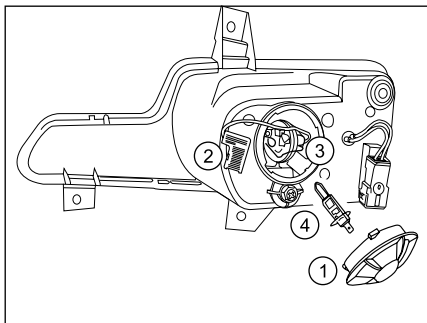

5

Front fog light

1. Open the cap counterclockwise.
2. Plug out power
3. Release its clamp with a side push
4. Replace the lamp according to baselines
5. Install the clamp appropriately
6. Plug in the power
7. Fix the cap clockwise.

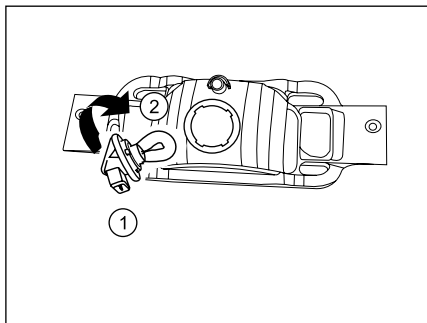

Back fog light

1. Plug out the power supply
2. Open the cap counterclockwise.
3. Release the lamp by pushing and pulling counterclockwise, and replace it.
4. Fix the cap clockwise.



WARNING

Plug out the main power supply before replacing the lamps, then plug it again after replacing the lamp.

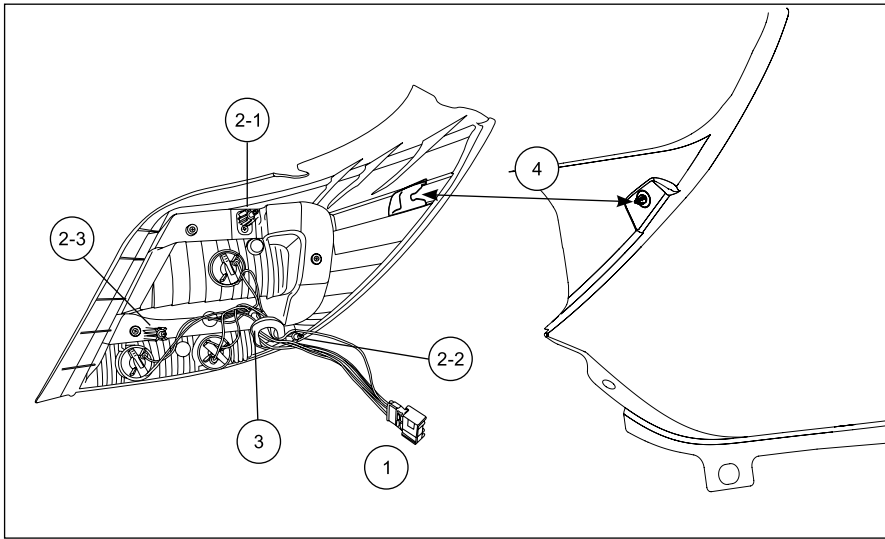

Back lamps set

In order to replace the back lamps:

Put out the back floor mat

1. Plug out the main power supply
2. Loose three screws of body connection and release whole set of back lamps.

After replacing the lamp:

3. Install the sealing rubber on its appropriate place.

- put the whole set of back lamps on tis appropriate position, so the three screws will be located on their own hole.

4. Adjust the side and fix it tightly

- Tightly fix three screws as shown in the image

5 - Plug in the main power supply

6 - Put in the boot floor mat in its appropriate place.

CHANGING LAMPS

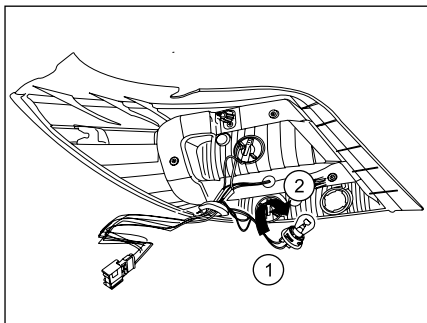

Rear gear light

5

1. Open the cap counterclockwise.
2. Release the lamp by pushing and pulling counterclockwise, and replace it using a clean cloth.
3. Fix the cap clockwise.

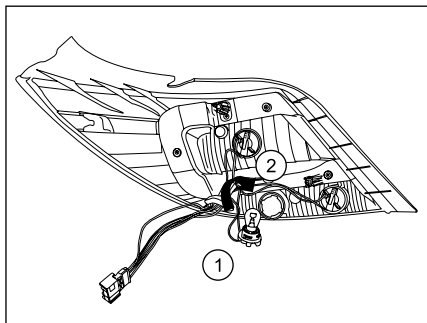

Back indicator light

1. Open the cap counterclockwise.
2. Release the lamp by pushing and pulling counterclockwise, and replace it using a clean cloth.
3. Fix the cap clockwise.

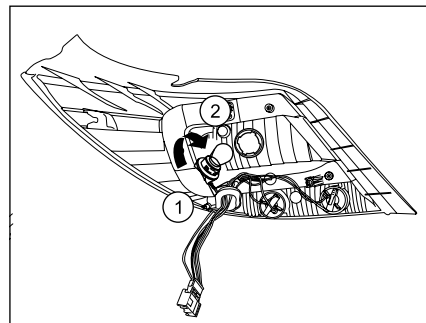

Brake light *

1. Open the cap counterclockwise.
2. Release the lamp by pushing and pulling counterclockwise, and replace it using a clean cloth.
3. Fix the cap clockwise.

* It's replaceable in Dena vehicle only

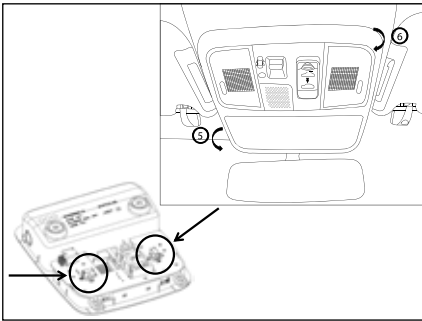

How to change the ceiling console lamps*

Changing of the lamps is carried out simply by using a Allen spanner. The method is described below stepwise.

1. Turn off the car.
- 2- Open the glasses place in accordance with the description of the previous section And evacuate it.
- 3- While the glasses place is open, Open the 2 screw below the compartment, using the Allen wrench,
4. Close the Place of the glasses.
5. Skip down obliquely the entire console from the front section of it
- 6- After pulling out the front part, pull the

rear part,exit with caution.

7. Now rotated counter-clockwise and take out each of the lamp which is required to be replaced, according to the figure below,

8. Replace the new Lamps and rotate them clockwise.

9. In order to install the ceiling console, perform part operations Reversely from 6 to 3 .

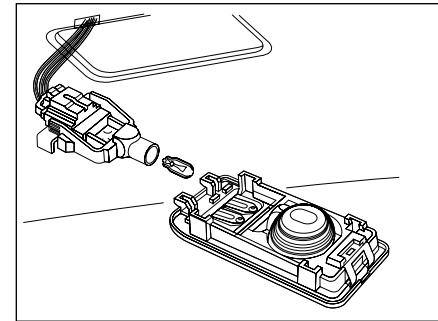
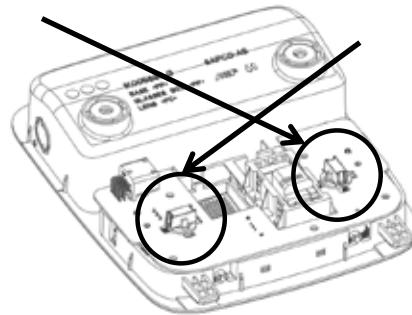

Back roof light

Put a screwdriver carefully at the tail of lamp and release the whole lamp set completely. Hold the whole lamp set and release the lamp base. Put out the lamp and replace it. Make sure that the base is fixed appropriately, and then fix the whole set in its correct location.

5

* It's replaceable in Dena vehicle only

CHANGING LAMPS

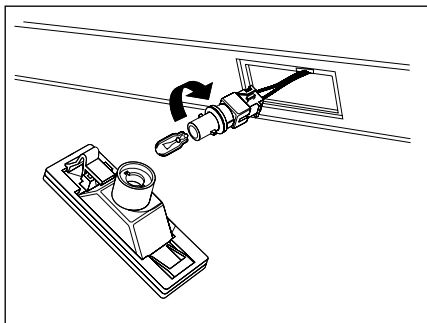

5

Vehicle's plate light

Pull the light into left side, then rotate it down to release it. Turn the lamp base and release it, release the lamp from its base. Replace the lamp.

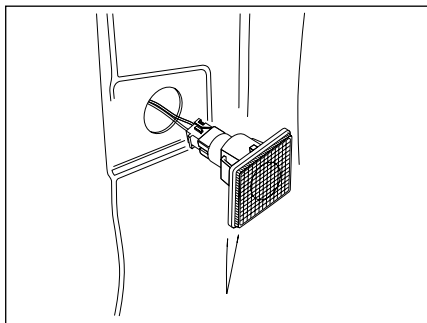

Door light

This light is equipped with the diode.
Please refer to IRAN KHODRO authorized workshop in case of any failure.

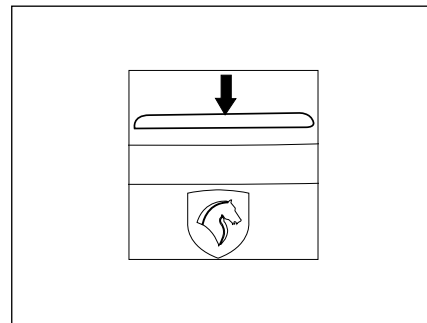

Third warning light (red)

This light is equipped with the diode.
Please refer to IRAN KHODRO authorized workshop in case of any failure.

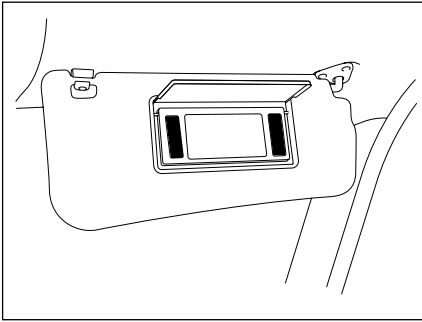

Make-up mirror light

This lamp is not renewable. To do that, you shall purchase the whole set from IRAN KHODRO authorized workshop.

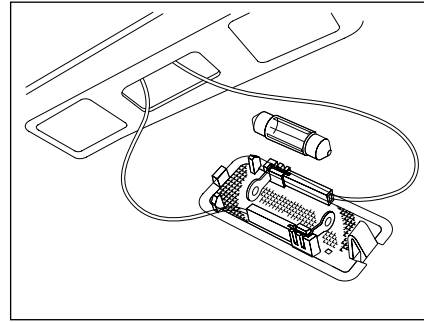

Boot light

Put a screwdriver at the tail of lamp line, take out the whole set and release the lamp, then replace it with a new one and appropriately put in the whole set in its correct location.

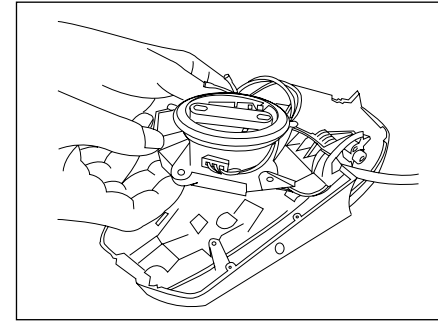

Indicator light on the mirror

First release the clamps of side mirror. Open the screws of mirror motor and mirror template, open two screws at the end and finally replace its LED with a new LED, and fix it again.

5



WARNING

Lamps are vacuum which may be broken at replacing and cause injury.

6 TECHNICAL INFORMATION

WARNING AND PLATES LABELS	146-147
ID NUMBERS	148
TECHNICAL INFORMATION OF THE ENGINE	150-152
FUEL CONSUMPTION	153
WEIGHTS	154
VEHICLE DIMENSION	155
POLLUTION CONTROL	156

WARNING LABELS AND PLATES

IRAN KHODRO(PUBLIC STOCK COMPANY)	
Type Approval	
Chassis	
Pay Load	G/VW
Asle 1	Asle 2
System	Year
Type	
Engine	
Cub	
Cap(D + F)	Color

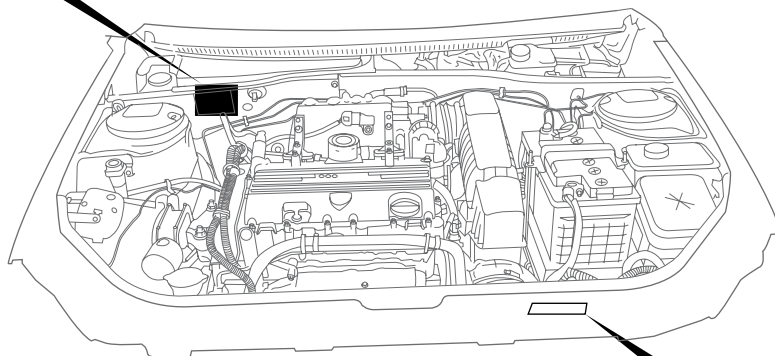

6

توجه

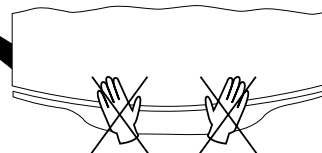

To open the hood:
Hold it in 30 cm distance, and then
release it to be closed.
Never force on the hood by hand.

WARNING LABELS AND PLATES

Manufacturer Proton Vehicle Model Power vehicle		Model Proton
Exit position Front / Rear / Side	Permitted location of exit position: Front / Rear / Side	
Exit position (mm) Front / Rear / Side	Exit position (mm) Front / Rear / Side	

Air bag Warning

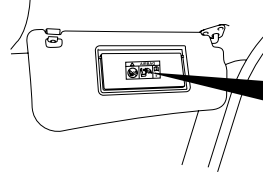

AIRBAG		

UNLADEN	LADEN	20G50R16
2.2 BAR 32 PSI	2.3 BAR 34 PSI	FRONT TYRE PRESSURE در چرخهای جلو
2.1 BAR 31 PSI	2.4 BAR 35 PSI	REAR TYRE PRESSURE در چرخهای عقب
SPARE WHEEL 105G0R15 2.5 BAR 37 PSI		
PRESSURE TO BE CONTROLLED COLD TYRE فشار باد لامپها در وضعیت خنک کنترل شود		

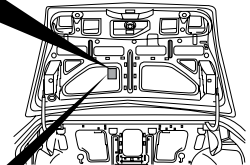

6

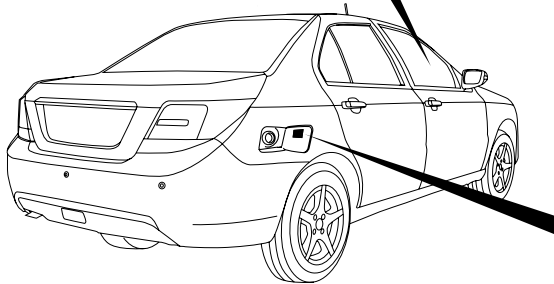

فقط بنزین بدون سرب با اکتان 95
 استفاده از بنزین سربدار یا با اکتان
 کمتر از 95 ممنوع است.
 استفاده از بنزین سوخته یا بنزین
 سوخته در موتور ممنوع است.
 افزودنی‌ها در بنزین ممنوع است.



**ONLY UNLEADED GASOLINE
 WITH AN OCTANE NUMBER
 OF 95 OR HIGHER
 ANY KIND OF ADDITIVES
 ARE FORBIDDEN**

2 BAR 29 P.S.I	رانندگی در شهر و حومه CITY AND ENVIRONS DRIVING	فشار باد چرخهای جلو	FRONT WHEEL TYRES PRESSURE
2.1 BAR 31 P.S.I	رانندگی در اتوبان FREEWAY DRIVING	فشار باد چرخهای عقب	REAR WHEEL TYRES PRESSURE
2 BAR 29 P.S.I	رانندگی در شهر و حومه CITY AND ENVIRONS DRIVING		
2.3 BAR 33 P.S.I	بنزینی PETROL دوگانه سوز BI FUEL		
2.1 BAR 31 P.S.I	رانندگی در اتوبان FREEWAY DRIVING		
2.4 BAR 35 P.S.I	بنزینی PETROL دوگانه سوز BI FUEL		
توجه! فشار باد تایرها را فقط هنگام سرد بودن میزبان کنید. ATTENTION: AIR PRESSURE MUST BE ADJUSTED IN COLD CONTITION			

ID NUMBERS

ID Numbers

You shall read out these numbers in case of contacting IRAN KHODRO workshops and have any question about the engine or gear box.

 IRAN KHODRO(PUBLIC STOCK COMPANY) 	
تایید نوع (T.A)	
شماره VIN (VIN)	
Pay Load	GVW
Asxe 1	Asxe 2
سال (Year)	سیستم (Sys)
نیم (Type)	
موتور (Eng)	
اتاق (Cab)	
رنگ (Col)	ظرفیت (D+P) Csp.

6

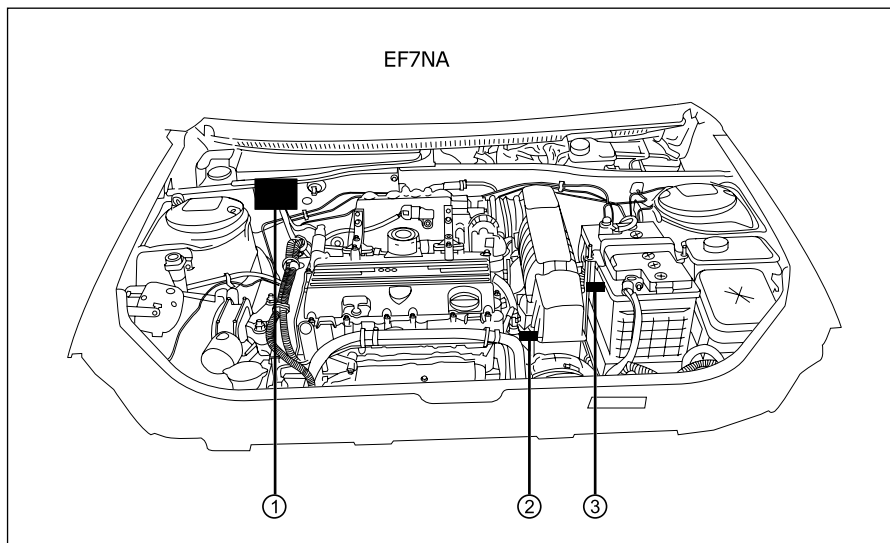

Vehicle's ID plate

- 1.The plate with vehicle's ID numbers inserted on it is located in hood, in a separate plate above the engine compartment.
- 2.Engine No.: this is inserted opposite cylinder block in a horizontal manner.
- 3.Gear box No.: this is inserted in front of gear box on a plate.

Characteristics / engine	EF7NA 1/7 i	EF7-TC - 1.7L
Capacity (cc)	1646	1645
Ignition priority	1-3-4-2	1 - 3 - 4 -2
Slow round of engine	750 rpm	850 rpm
Inner diameter of the cylinder	78.6 mm	78.6 mm
Pistons stroke	85 mm	85 mm
Number of cylinders	4	4
Number of valves	16	16
Compression ratio	11:1	9.5 : 1
Gear box	BE 3 5gears+1 rear gear	BE 4 5gears+1 rear gear
Maximum engine capacity (gasoline consumption) Maximum engine torque (gasoline consumption)	115 hp at 6000 (rpm) 157NM/4500(rpm)	150 hp @ 5500 rpm 215 N.m @ 2200 - 4800 rpm
Fuel octane	95	95

ENGINE TECHNICAL DATA

Capacities and consumable	
fuel tank	60 L
Gear box (dry mode)	1.9 L
Cooling system (dry mode)	Capacity: 7.5 L (ethylene glycol fluid /mixing ratio is 46 to 54, antifreeze and water)
Windows washer tank	3.4 L
Windows washer liquid	Isopropanol liquid - Mixing ration is 17 to 83 washer liquid /water(in summer) - Mixing ration is 44 to 56 washer liquid /water(in Winter)
Hydraulic steering wheel oil	1.2 L (ATF Dexron II-D oil)
Brake oil	0.52 L (ABS) (DOT4)

Note: Use the approved brand of products or the packages distributed by ISACO.

Technical characteristics of appropriate engine oil to be used for EF7 engine			
Allowed engine oil (standard with high quality)*	EF7-NA		EF7-TC
	SAE10W40 API SL/SJ		SAE10W40 API SL
Volume of needed engine oil at the time replacement	with filter	4.9	4.9
	without filter	4.7	4.7
Correct KM of oil replacing	Every 10000 Km		Every 10000 km
Oil filter	Cartridge type		Cartridge type
Oil filter replacing time	It must be changed along with engine oil		It must be changed along with engine oil
Engine oil checkup period	Oil level must be checked in every 1000 km ,The Min. Qty is 4.45 L & the Max. Qty is 5.2L		Oil level must be checked in every 1000 km ,The Min. Qty is 4.45 L & the Max. Qty is 5.2L
Allowed vaporization of engine oil per 1000 km	0.2 Liter (200 cc)		0.2 Liter (200 cc)

Important tip:

All SAE 20W50 pols are not allowed in EF7 engine.

* Note : Use the approved brand of products or the packages distributed by ISACO.

ENGINE TECHNICAL DATA

Battery details		
Type of battery	MF & SEALED	
Voltage	12 v	
Charge system	Alternator	
Cooler		
Type of cooler gas	R-134a	
Ring and Tires		
Ring type	steel	Aluminium type*
Ring Dimensions	6J15	6.5 J16
tires	185/65R15	205/50R16
Dimension of Spare ring	6J15	-----
Spare Tire	185/65R15	195/60R15

* If installed in your car

Adjust it		
Tires air pressure	Front	Rear
in normal condition of driving (in city and suburban)	2 bar (29 psi)	2 bar (29 psi)
Driving in highways	2.1 bar (31 psi)	2.1 bar (31 psi)

Adjust it		
Tires air pressure	Front	Rear
Max. permitted load	2.3 bar (34 psi)	2.4bar (35 psi)
Min. permitted load	2.2 bar (32 psi)	2.1 bar (31 psi)
wheel Tire	2/5 bar (37 psi)	

6

Fuel Consumption

In order to decrease the fuel consumption and accessing the least fuel consumption, please pay attention to the following tips:

1. Always make sure of appropriate functioning of engine by means of periodical inspections according to the user manual for example for air filter on-time replacing.
2. Make use of appropriate tires for the vehicle according to the use manual and always adjust the tires air pressure.
3. Drive at patience and avoid sudden brakes and speedy driving.
4. Avoid driving at high speed at roads.
5. Put out extra objects from the vehicle.
6. Power off the vehicle's engine in long stops.
7. Plan for inter-city driving so as not to drive at rush hours and not to stock long hours in the traffic.
8. Park the vehicle in appropriate places in different seasons, for

example in respect of sunlight or snowing, and try to park your vehicle in roofed parking.

9. Try to make use of heavy gear when you are driving at slope roads in way that there is no need to press the gas pedal anymore.

Engine Fuel Consumption	DENA (EF7NA Petrol based)	DENA + (EF7NA Petrol based)	DENA + Turbo (EF7 –TC)
Min combined Mileage (urban & suburban) As per standard ECER 101	7.74 liter / 100 km	7.94 liter / 100 km	7.94 liter / 100 km

WEIGHTS

DENA (kg)	
Weights (kg)	Engine
	EF7 Engine (gasoline consumption)
	EF7 NA
Approximate vehicle weight without passenger with full fuel tank and without extra equipment	1258
Maximum vehicle weight with passenger and load	1650
Maximum allowed load of back axles	810
Maximum allowed load of front axles	900

VEHICLE DIMENSIONS

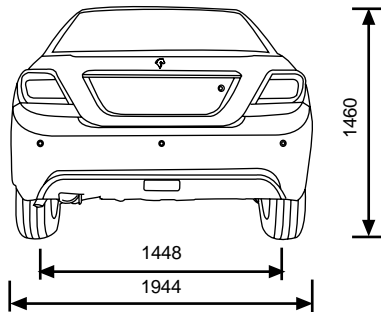
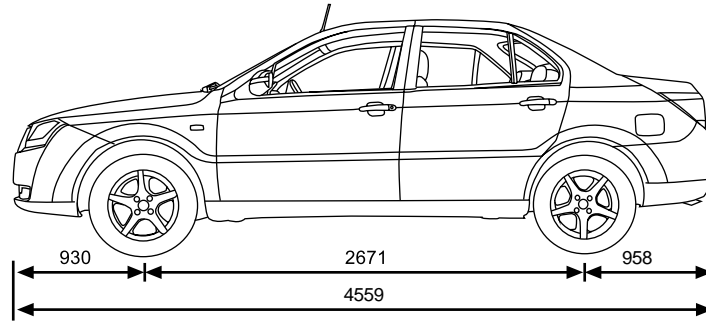
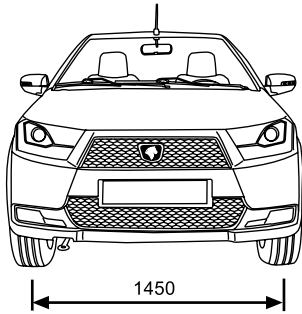

Length of vehicle	4559 mm
Vehicle's width with side mirrors	1933 mm
Vehicle's height	1460 mm
Distance of wheels	2671 mm
Front wheels axle distance with front shield	930 mm
back wheels axle distance with back shield	958 mm
Wheels width distance	1450mm
- Front	1448 mm
- Back	
Turning steering wheel to lock	3.1
Vehicle's turning circle diameter	11 m
Boot capacity	500 L

AIR POLLUTION CONTROL

Air pollution control

Fortunately, your vehicle is equipped with a modern air pollution system in order to control automobile pollutants.

Catalyst converter

A catalyst converter or catalyzer is designed in your vehicle in order to convert output gases into non-pollutant gases.

Leaded gasoline is the most effective factor in failure of this system, hence, making use of unleaded gasoline is necessary.

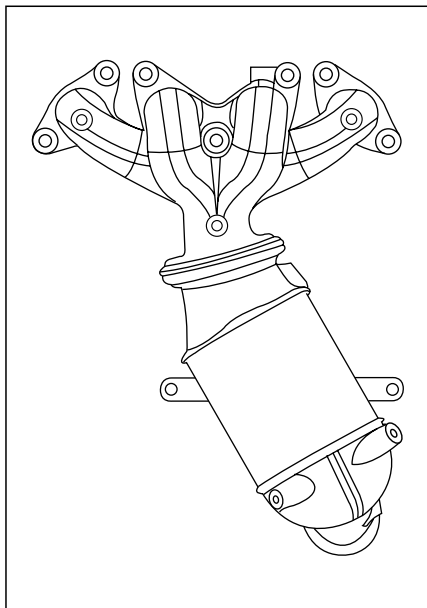

CAUTION

Negligence in making use of unleaded gasoline will damage your vehicle's catalyst.

Avoid adding any non-original additives like injector washers, gasoline oil and gasoline octane protector with the standard unleaded gasoline.

7 ALPHABETIC TABLES OF CONTENTS

INDEX

A		Battery replacing	109	Doors automatic unlocking	28
ABS brake	93	Battery safety considerations	124	Doors light replacing	138
Activating alarm system	65	Battery service and maintenance	124	Doors locking/unlocking	28
Adjusting steering wheel angle	59	Body color polishing	114	Driver's companionship in dark areas	64
Airbag	94	Boot access gate	61		
Alarm system	65	Boot light replacing	139	E	
Ampere indicator lights	71	Boot locking/unlocking	29	E-brake force distributor system	94
Anti-freezing	105	Boot opener key	62	Elbow	61
Anti-obstacle protective system*	52	Brake light replacing	134	Electric folding mirror*	50
Auto towing with a truck	123	Brake oil	106	Electric mirror adjustment	49
Automatic air ventilation	56			Engine compartment guide	103
Automatic locking	65			Engine oil level monitoring	104
		C		Engine oil monitoring	106
B		Capacities and consumables	149	Engine's technical information	148
Back ashtray	59	Car wash	112		
Back fog light replacing	134	Catalyst converter	146	F	
Back fog lights	87	Central lock key	62	Fastening seat belts	45
Back indicator light replacing	136	Central lock	62	Firefighting capsule*	47
Back obstacle warning system	83	Children protection safety lock	29	Flashers	62
Back roof light replacing	137	Children safety	38	Foot brake with booster	90
Back roof light	54	Coolant liquid monitoring	105	Force pretension and limiter system	46
Back towing	123			Front ampere audio alarms	77
Back windows locking key	51	D		Front ampere display screen	70
Battery	108	Daily monitoring	98	Front ashtray	59
Battery charging with charger device	126	Dashboard	61	Front fog light replacing	134
Battery common failures	108	Digital display guide	74	Front fog lights	87
Battery instant charging	125	Dismantling sport ring	120	Front glove box	60
		Doors automatic locking	28		

Front high beam light replacing	133	Hydraulic steering wheel oil monitoring	107	Make-up mirror light replacing	139
Front indicator light replacing	133	Hydraulic steering wheel	107	Manual gear box	82
Front lights height adjustment	88			Manual locking/unlocking	29
Front low beam light replacing	133	I		Mirrors indicator lights replacing	139
Front mirror	49	ID numbers	147		
Front roof light replacing	137	Ignition switch	81	P	
Front roof light	54	Inactivating alarm system	65	Pollution control	148
Front seat belt height adjustment	45	Installing snow wiper	111	Pouring brake oil	104
Front towing	123			Pretension seat belt	46
Fuel consumption	151	J		Putting jack beneath the vehicle	119
Fuel consumption reduction and environmental protection	82	Jack location beneath the vehicle	119		
Fuel restart key	86			Q	
Fuel system	85	K		Qualitative tips of car wash process	115
Fuel tank cap	85	Key set	28		
Fuse box FN	129	Keys of Audio equipment on steering wheel	63	R	
Fuses	127			Radiator filling	105
		L		Rear gear light replacing	136
G		Lamps replacing	132	Remote battery replacing	31
Gears position	83	Left and right indicator lights	87	Remote locking/unlocking	28
		Lights keys	87	Roof light timer	64
H		Locking hood	102		
Handbrake	91	Locking steering wheel	81	S	
Heating and ventilation	55			Safety anti-theft points	30
High and low beams lights	87	M		Safety in garage	101
Hood unlocking	102	Maintenance	98	Safety points at Driving	83
Horn	87	Make-up mirror	50	Seat belts safety considerations	44
				Seats	33

INDEX

Side windows	51	Vehicle ID Plate	150
Smart Speed Control (Cruise)*	78	Vehicle searching	64
Smart windows lifters*	52	Vehicle towing	122
Snow wiper single cycle	88	Vehicle washing and maintenance	112
Snow wipers and windows washer	88	Vehicle's alarm system	32
Snow wipers dismantling	111	Vehicle's back towing hook	122
Snow wipers washing	114	Vehicle's equipment maintenance*	113
Spare tire and its tools	118	Vehicle's front towing hook	122
Starting and driving	81	Vehicle's ID Plate light replacing	138
Steering wheel unlocking	81		
Sun visor	60	W	
		Warning alarm	86
T		Warning and plates labels	148
Tank cap	85	Warning triangle	118
Tar sports cleaning	114	Washing beneath the vehicle	112
Third warning light replacing	138	Washing vehicle's inside	114
Tire rotating in vehicle	121	Weekly monitoring	98
Tires air pressure	121	Weights	155
Tires erosion indicator	121	Wheels replacing	118
Tools	118	Windows and mirrors washing	114
Toxic liquids	101	Windows keys	51
Tools	118	Windows washer tank filling	110
Toxic liquids	101	Windows washing	88
V			
Vehicle body protection	123		
Vehicle dimensions	153		

Roads await you ...



IRAN KHODRO Company (Public Joint Stock)

Gate No. 1, Iran Khodro Blvd,
KM.14 Karaj Makhsous Rd,
Shahid Lashgari Highway,
Tehran, IRAN
Postal Code:1389913657
Tel: (+9821) 48901
Fax: (+9821) 44934000-1
SMS Centre: (+98)30003
E-mail: info@ikco.ir
www.ikco.ir