

DONG FENG

DONG FENG H30 CROSS
DONG FENG S30

Owner's Manual

This Manual has been prepared for owner's reference to vehicle's performance, safety, maintenance and everyday use guidelines. Keeping the manual in your car is recommended for quick reference.



In The Name of God



OWNER'S MANUAL
DONG FENG (H30 CROSS - S30)

DEAR BUYER

We're thankful for choosing Iran Khodro product and we congratulate you for this good selection. We hope this new vehicle contributes in happy moments of your life.

This manual helps you enjoy driving. Therefore to have an easy access, it would be advisable to be kept in your glove compartment. The manual is divided into some sections for your convenience, and deals with various aspects of driving or maintenance of the car. Before driving: Includes seat adjustment, Safety belts, heating and ventilation control system and also every other thing you needed to know in order to settle comfortably.

Driving Controls: explain functions of switches, equipment and precautions.

Maintenance: Includes information about the checks you should carry out regularly.

Note:

Please refer to maintenance and guaranty services manual to know about the vehicle maintenance, regulation & condition of guaranty services and periodic services.

Technical emergencies: Help solve some of unavoidable small emergencies occurring occasionally like replacing lamps fuses or changing wheels.

Technical data: It includes some information about engine, dimensions, capacities and weights.

WARNING, CAUTION and NOTE have special meanings. These special meanings apply except when laws or regulations require that the signal words be used with a different meaning. Pay special attention to the messages highlighted by these signal words: In the meanwhile consumptive material must be provided through authenticated representatives of IKCO.



WARNING: Indicates a potential hazard that could result in death or injury.



CAUTION: Indicates a potential hazard that could result in vehicle damage.

NOTE: Indicates a serious damage to your vehicle in the case of not paying attention to the warning and caution signals.

Important Point: The specification of each vehicle will vary according to its type. Therefore some information of this manual may not be true about your vehicle. For any more information, you can consult with IRAN KHODRO dealers.

Reminder: Information about other varieties of this product have been mentioned in this manual and denoted by asterisk (*).

YOUR VEHICLE AT A GLANCE 1

DRIVING 2

VEHICLE EQUIPMENT 3

MAINTENANCE 4

OPERATIONAL RECOMMENDATIONS 5

TECHNICAL CHARACTERISTICS 6

INDEX 7

OVERVIEW

REMOTE CONTROLLER	16
AIRBAG	35
CHILD SAFETY	53
INDICATOR LAMP AND WARNING LAMP	64
STEERING WHEEL*	79
ENGINE START	85
TRANSMISSION	90
ELECTRIC POWER STEERING	96
AUTOMATIC A/C*	105
INTERIOR LIGHTING & TRUNK LIGHTING	109
TRUNK	113
SUNROOF*	118
INTERIOR MAINTENANCE	125
BODY MAINTENANCE	127
FUSE	133
BATTERY	137
GENERAL TECHNICAL CHARACTERISTICS	156
VEHICLE IDENTIFICATION	159

*If equipped

Foreword

The pictures, data and relevant notes in the user's manual conform to the definition of product upon preparation of the manual. IKCO is continuously dedicated to improving the appearance, interior trims and technical specifications of the vehicle. The pictures, data and relevant notes in this manual are inapplicable as basis for order acceptance.

Applicable models of this manual:

Series	Engine	Transmission	Announced model China IV Emission Standard	Announced model China V Emission Standard
S30	N6A 10FX3A PSA	MT	DFM7160B1E	
		AT	DFM7160B1D	
		MT	DFM7160B1F	DFM7160B1F5
		MT	DFM7160B1F1	
	DFM A16	MT	DFM7150B1A2	DFM7150B1C
		AMT	DFM7150B1B	DFM7150B1D
H30	N6A10FX3A PSA	MT	DFM7160B2E	
		AT	DFM7160B2D	
		MT	DFM7160B2F	DFM7160B2F5
	DFM A16	MT	DFM7150B2A2	DFM7150B2C
		AMT	DFM7150B2B	DFM7150B2D
H30 CROSS	N6A10FX3A PSA	MT	DFM7160B3C	
		AT	DFM7160B3B	
		MT	DFM7160B3F	DFM7160B3F5
	DFM A16	MT	DFM7150B3A2	DFM7150B3C
		AMT	DFM7150B3B	DFM7150B3D

YOUR VEHICLE AT A GLANCE

This manual is mainly prepared to introduce the models in above-mentioned series; therefore, some equipment and functions may not be provided on your vehicle.

The “**” mark in this manual means that the provision of the marked equipment/function is dependent on your model.

The legends in this manual are for operation introduction only and the pictures for S30 sedan (equipped with DFM A16 engine, automatic & manual transmission, automatic A/C and MP5 audio system etc.) shall prevail if common to three models.

Your Dongfeng car is installed with various advanced automotive electronic control units and can only be maintained and serviced either by the Dongfeng Franchise Store; or IKCO authorised representatives; otherwise, your car may lose the technical and quality guarantee.

IKCO Company reserves the right to modify the model, equipment or equipment function, without prior notice.

Iran Khodro Industrial Group

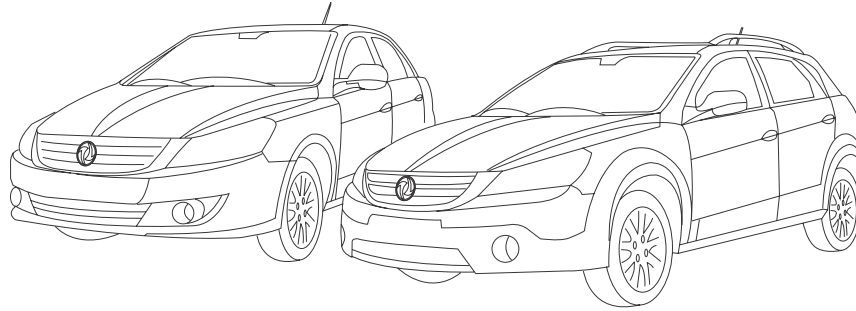

Thanks for choosing this model.

Before driving on road, please read this user's manual carefully.

This manual covers driving modes, important information on equipment, suggestions to be followed strictly as well as service/maintenance and precautions, so as to ensure your personal safety and car reliability.

Comprehensively understanding your car may bring you more driving pleasure.

Due to the specifications and options of your new car as well as different purchase time, some equipment/functions described in this manual may not be provided or not be reflected in time on your new car.

YOUR VEHICLE AT A GLANCE

Warning Notices

1. Please always read this manual carefully and follow the operation modes herein before and during your driving, so as to make yourself familiar with the vehicle operation and maintenance and contribute to your driving safety; or else, the vehicle will be used improperly and we will not be responsible for the resultant losses.

2. Please always have your vehicle maintained regularly at either Dongfeng Franchise Store or IKCO authorised representatives as per the Warranty Manual.

3. To accommodate to the drivers in different shapes, make the following adjustments to the driving position:

- Headrest height, fore-and-aft position, backrest inclination, cushion height*;
- Position of steering wheel;
- Height of safety belt.

4. Safety belt is an important guarantee for occupant's safety. Children and adults at different ages shall wear safety belt or apply other security devices by the method fitting their body.

5. The airbag will be effective only when the safety belt is wore.

6. Inspection before driving:

- Inspect the lamps for normal operation;
- Inspect the windshield and rearview mirror for cleanliness, and the wiper for normal operation;
- Inspect the position of rearview mirror;
- Inspect the tyre pressure and wear condition. The tyre condition directly influences the dynamic performance, economy and ride comfort of the vehicle, especially the driving safety.

Therefore, please use and maintain the tyre (including the spare wheel) properly as per the relevant regulation. Inspect the tyre pressure when the tyre is cold (see Pages 153-155);

- Inspect the level of such fluids as engine oil, brake fluid, power steering fluid and coolant (see Pages 123-127):
 - Inspect the oil level 10 min after the engine is stopped;
 - Inspect the coolant level when the engine is cold;
 - Do bleeding before adding a great quantity of coolant (when there is no coolant in the expansion tank) or changing coolant, as air, if any, in the cooling system may result in local

overheating of engine;

- Inspect the battery condition (see Page 143).

7. Inspect all warning lamps before the engine start (with ignition switch at M position) (see Page 81).

8. Engine running:

- Do not run the engine in enclosed depot to avoid poisoning by exhaust gas;
- Do not start the engine when the battery is under charge, because the engine electronic control unit and the starter cannot operate normally at this moment;
- It is not necessary to depress the accelerator pedal when starting the engine;
- After high-speed driving, run the engine at an idle speed for 3-5 min, and then turn off the ignition switch.

9. Fuel cut-off device (see Page 19).

10. Braking:

- When the engine is shut down, the vacuum booster will not work and the brake efficiency will decrease substantially due to the considerable increase of brake pedal force; therefore,

it is strictly prohibited to coast the vehicle when the engine is shut down;

- Before leaving the vehicle, apply the parking brake and confirm that it works reliably. For vehicle with automatic transmission or automatic & manual transmission, set the shift lever to P gear at the same time (see Pages 87-92);

- In the course of emergency braking or braking on a wet or slippery road, the ABS can inhibit the wheel from locking, contributing to the reliability of the driving direction. However, prudent and safe driving is still a must (see Pages 93-94).

11. If any red warning lamp (such as for charging, braking, engine oil, water temperature etc.) on the instrument panel is on during driving, stop the vehicle safely as soon as possible and check it as per this manual. If it is necessary, contact either Dongfeng Franchise Store or IKCO authorised representatives.

If any yellow warning lamp on the instrument panel is on during driving, check the vehicle as per this manual and contact either Dongfeng Franchise Store

or IKCO authorised representatives when necessary (see Pages 62-63).

12. Electrical accessories:

For any added electrical accessory, the wiring operation shall be performed either by Dongfeng Franchise Store or IKCO authorised representatives as per the connecting positions and wiring method.

13. It is strictly forbidden to use leaded gasoline to avoid damaging the three-way catalytic converter installed on the vehicle (see Pages 20-21).

14. Safety tips:

Follow the following critical driving rules to contribute to the safety of yourself and passengers throughout the driving!

- Strictly abide by the traffic rules to drive the vehicle safely;
- Do not drive the vehicle after drunken or drugged;
- Make sure to observe the speed limit marks and do not overspeed;
- Make sure to apply the safety belt and corresponding child restraints and let the children take the rear seats.

15. Protect the dashboard against water

invasion, and pay special attention to film application on the front windshield, wet umbrella and water cup, etc.; otherwise, the instrument and electric appliances may be damaged.

16. Do not retrofit the vehicle, or else, its performance, safety or durability may be influenced, and relevant rules and regulations may be broken. Furthermore, the damage or performance issues resulting from such retrofitting operation is out of the scope of quality guarantee.

Illustrated Index – Exterior

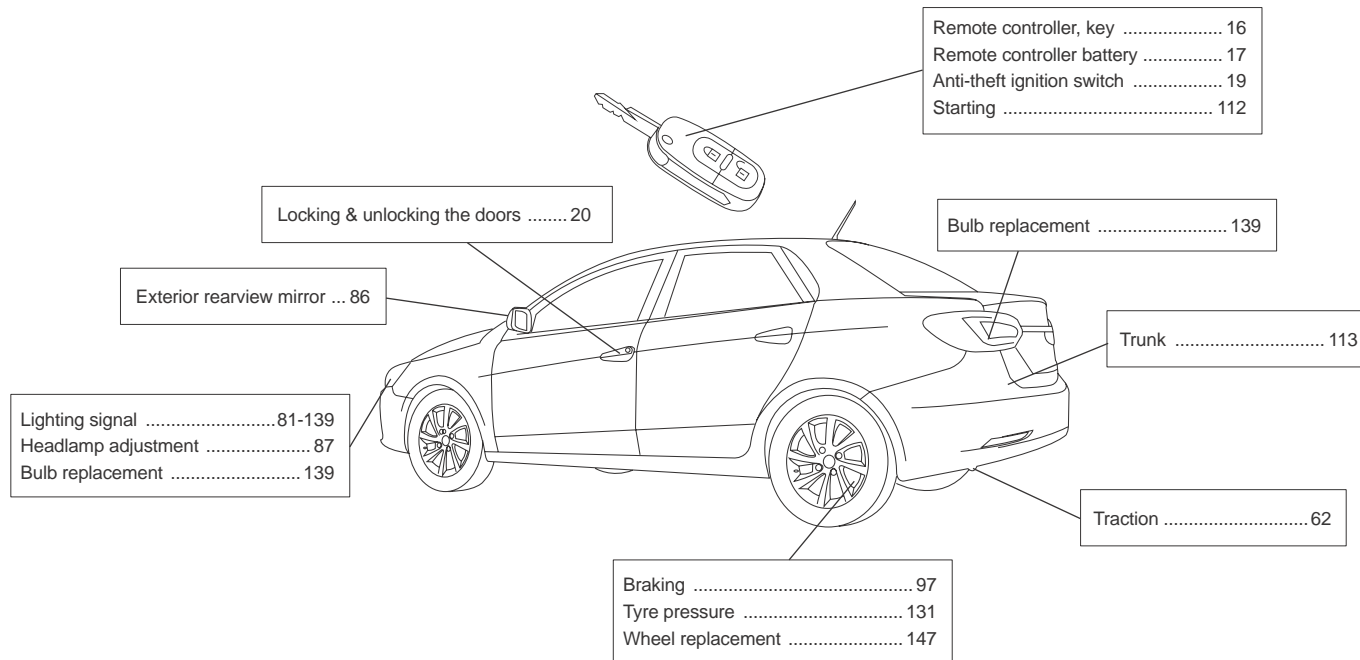

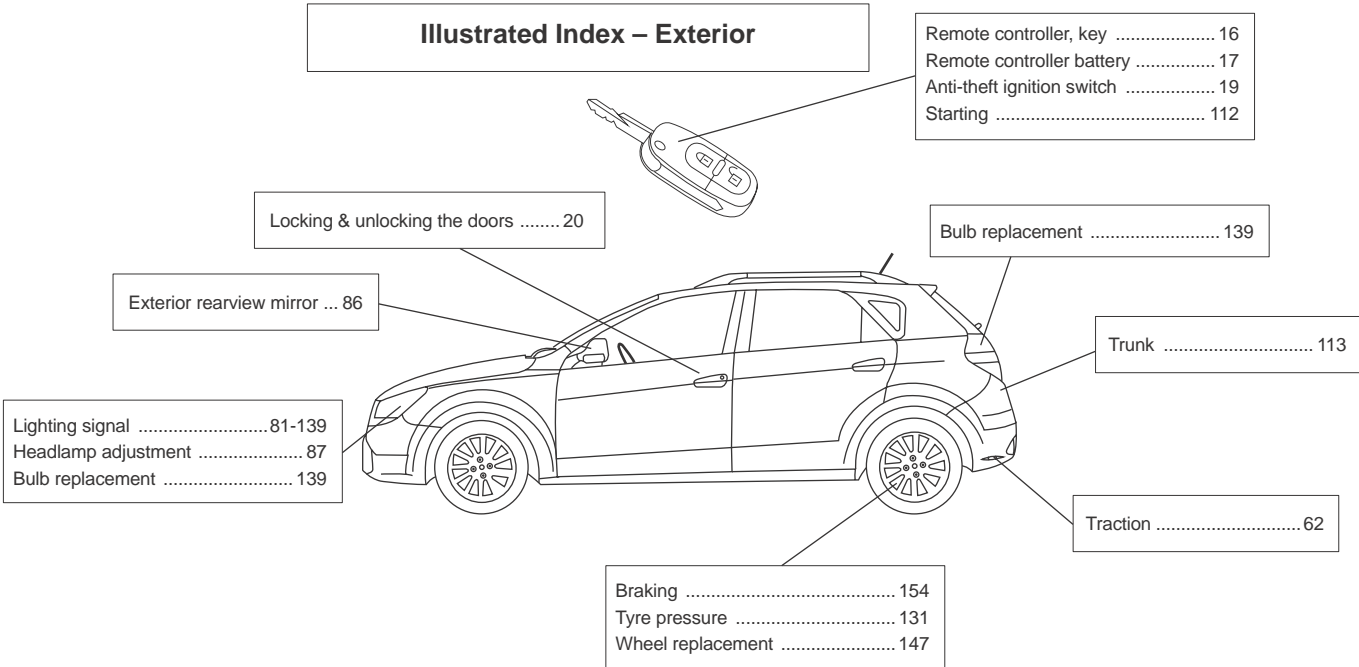

YOUR VEHICLE AT A GLANCE

Illustrated Index – Driving Position

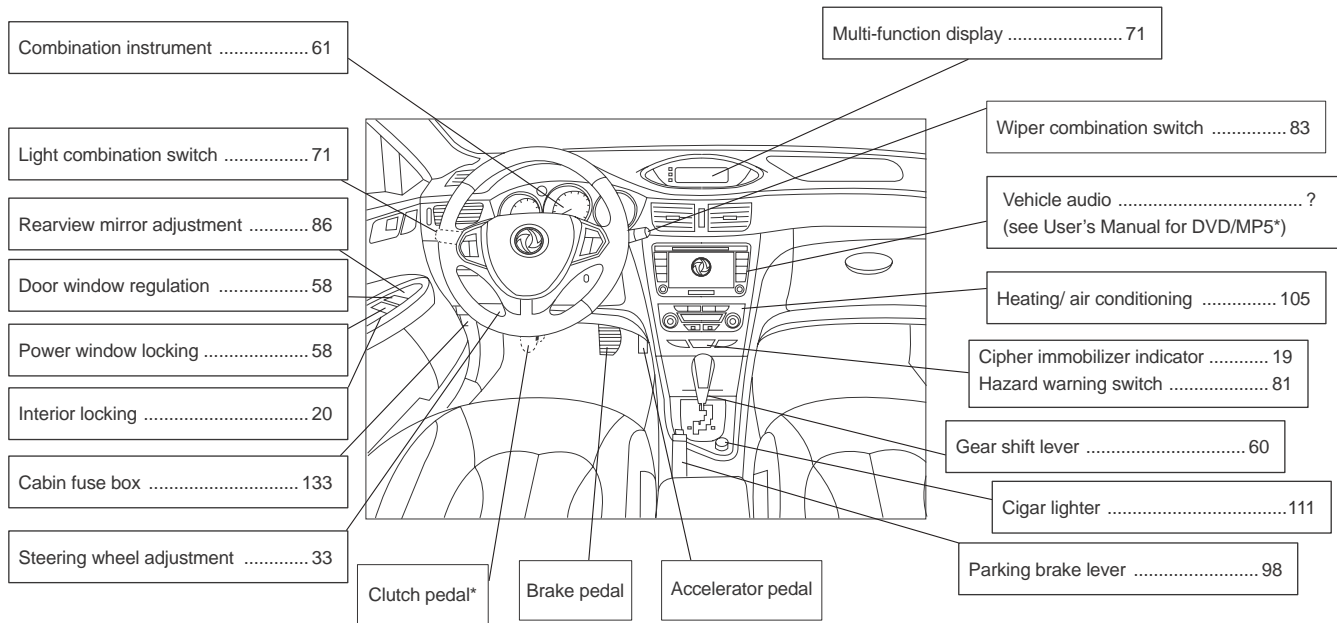

Illustrated Index – Interior

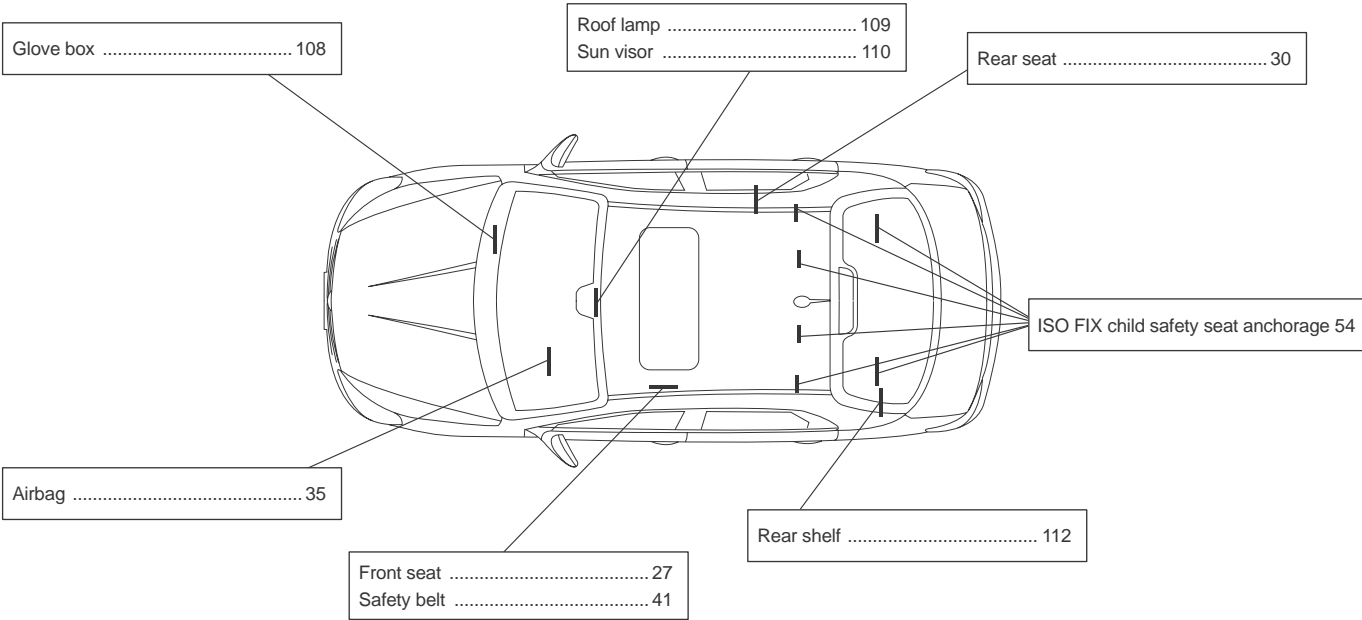

Illustrated Index – Basic Performance of Complete Vehicle

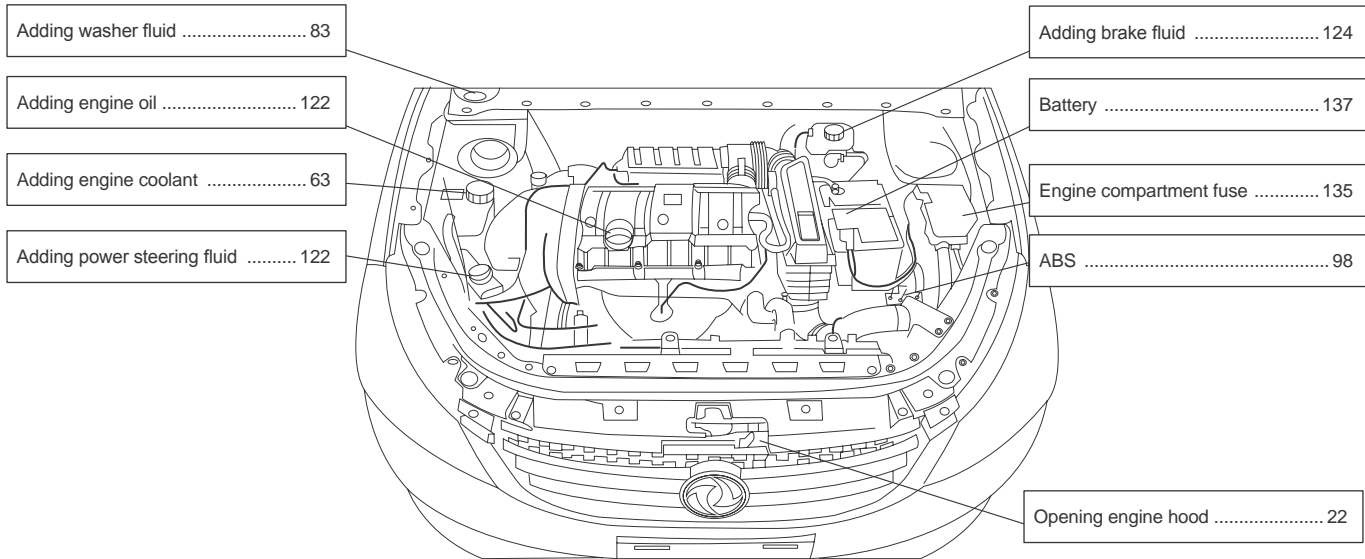

1 YOUR VEHICLE AT A GLANCE

REMOTE CONTROLLER	16	INDICATING INSTRUMENT	62
KEY	18	INDICATOR LAMP AND WARNING LAMP	64
DOOR OPENING/CLOSING	20	COMBINATION DISPLAY	67
CHILD SAFETY LOCK AND TRUNK LID (LIFTGATE)	21	MULTI-FUNCTION DISPLAY (SEGMENT CODE)	71
ENGINE HOOD OPENING/CLOSING	22	STEERING WHEEL *	79
AIRBAG	35	H30 CROSS ROOF RACK	80
SAFETY BELT	41	LIGHT COMBINATION SWITCH AND HAZARD WARNING LAMP	81
CHILD SAFETY	53	WIPER COMBINATION SWITCH	83
SAFETY BELT MAINTENANCE	57	ENGINE START	85
DOOR WINDOW REGULATION	58	REARVIEW MIRROR	86
DASHBOARD	59	HEADLAMP ADJUSTMENT	87
COMBINATION INSTRUMENT	61		

REMOTE CONTROLLER

1

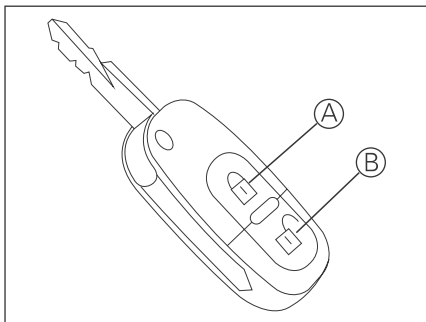

Remote controller

The remote controller is configured in the master control key handle.

The remote controller, with a high-frequency transmitter, embraces the following advantages:

- Accessible for a range more than 6m around the vehicle.

Note: Have either Dongfeng Franchise Store or IKCO authorised representatives correct the fault, if any.

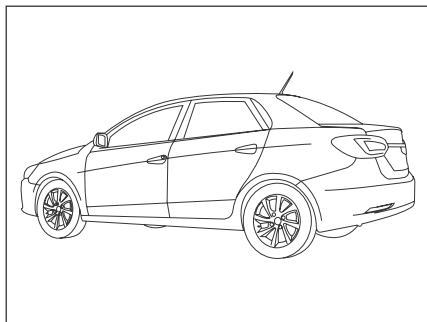

Remote-controlled electric central locking

Use the remote controller to unlock/lock doors and the trunk lid with (A) as locking button and (B) as unlocking button. The operation is indicated by flashing of turn signal indicator lamp.

Unlocking: The turn signal lamp flashes for 3 times.

Locking: The turn signal lamp is on for 2 s, and the remote controller will be inoperative when the ignition switch is in ON position.

Automatic locking restoring: If no door (incl. trunk lid) is opened 20 s after unlocking by remote controller, all door locks will be locked again automatically.



Note :

Ensure that all doors and the trunk lid are properly closed when using the remote controller for locking.

After the remote controller sends a locking signal, the locking will fail if any one of doors or the trunk lid is left open or virtually closed. Continuous and repeated locking/unlocking operations with remote controller will make the central control system inoperative in short time, which is normal because the motor is being protected. However, please do not operate like that.

Searching function in parking lot

In parking lot or underground garage, when all doors are locked, after the locking button (A) on the remote controller is pressed down twice (with an interval of 1-3s), the horn will sound for 5 times and all turn signal lamps will flash for 15s approximately to facilitate you find out your own vehicle quickly by following those audible and visual indications, which, however, can be terminated by pressing down the locking button (B) again when the searching function is activated.

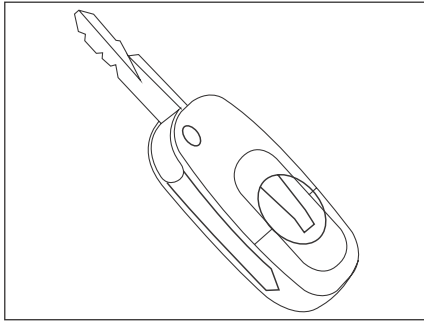

Battery run-out

When the remote controller fails to operate normally at a distance shorter than 6m, have the battery inspected or replaced at either Dongfeng Franchise Store or IKCO authorised representatives.

Replacement of remote controller battery

Open the remote controller box to replace the battery.





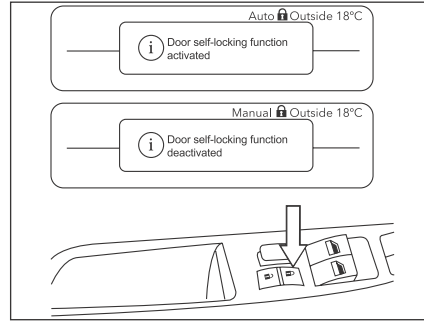

Battery: 3V CR2032

Note: To protect the environment, do not throw away the waste battery but send it to the designated recovery place.



Activation/deactivation of automatic locking during driving

The automatic locking function can be activated or deactivated as follows:

- Turn the ignition switch to M position when the vehicle is stopped.
- Press down the locking button  on the door at the driver's side for 2s. Afterwards, the dot-matrix multi-function display will show the indicating words and the symbol of "manual  " or "automatic  ". Pressing and holding the locking button  will enable a switch-over between activation and deactivation of the function. The segmentcode type multi-function display will show the symbol of "manual  " or "automatic  " only, without the indicating words.

Automatic locking during driving

After the vehicle is started and runs at a speed more than 10km/h and all doors (incl. trunk lid) are closed, the door locks will be locked automatically, unless the doors (incl. trunk lid) are not properly closed.

This function can prevent other people from pulling the door open and entering into the vehicle when the vehicle stops at the red traffic light or in other cases, but will also inhibit the rescue by others in accidents. Whether to activate this function is up to the driver.

KEY

1

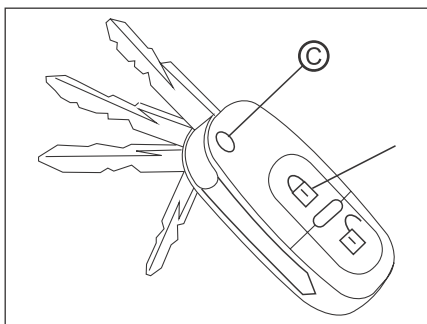

Before leaving the vehicle:

- Close all door windows and do not leave valuable matters in the vehicle.
- Remove the ignition key, turn the steering wheel to lock it and close all doors.

Each vehicle is provided with two keys. One is the electronic anti-theft starting master control key with remote controller, and the other is that without remote controller.

Make the key prop out by pressing down the button **C**, and press down the button **C** before folding the key.

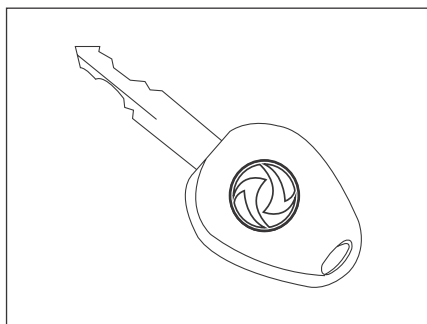

The key can be used to connect the ignition switch as well as open and lock the door and fuel tank cap individually.

Electric central locking

All doors and the trunk lid can be unlocked or locked at the same time by inserting the key into the lock hole at driver's side, but the turn signal lamp will not be lighted in this case.



NOTE :

If the door (incl. trunk lid) is left open or not properly closed, the electric central locking cannot function. And in this case, only the door at the driver's side may be locked, with other doors left unlocked.



NOTE :

When the battery runs out, only the door at the driver's side will be unlocked/locked, with other doors inactive.

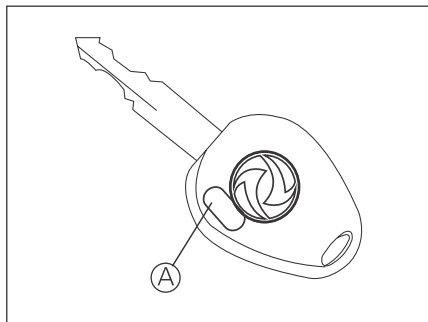

Electronic anti-theft starting key

The key with the electronic anti-theft starting function has an anti-theft starting response chip (A) inside, and only your key can start your vehicle. The key can be used to connect the ignition switch as well as lock/unlock the door and fuel tank cap individually.

Insert the key into the steering wheel lock; after the ignition switch is connected, the key will be recognized for the cipher against the electronic anti-theft starting device.

The vehicle cannot be started if the key fails to be recognized.

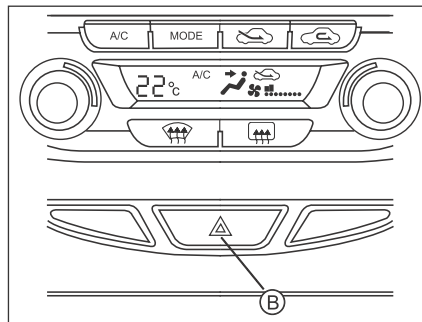

Cipher immobilizer indicator lamp

The electronic anti-theft starting device can cut off the engine fuel supply; when the ignition switch is turned off, the cipher immobilizer indicator lamp (B) on the hazard warning switch will flash constantly to indicate that the immobilizer is activated.



NOTE :

If the cipher immobilizer indicator lamp (B) fails to light up under the above-mentioned conditions, please consult with either Dongfeng Franchise Store or IKCO authorised representatives.



NOTE :

Do not change the circuit of electronic anti-theft starting device in no case, or else, the vehicle will fail to be started.

DOOR OPENING/CLOSING

1

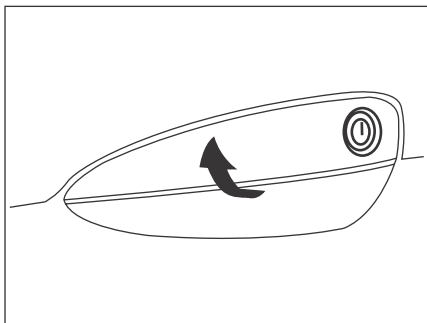

Opening the door outside

Press down the unlocking button on the remote controller or insert the key into the left front door lock hole to unlock the four doors and the trunk lid, and then open the doors by the outside door handle or the trunk lid by the trunk lid switch.

Locking the door outside

After closing doors and trunk lid, press down the locking button on the remote controller or insert the key into the left front door lock hole to lock doors and trunk lid.

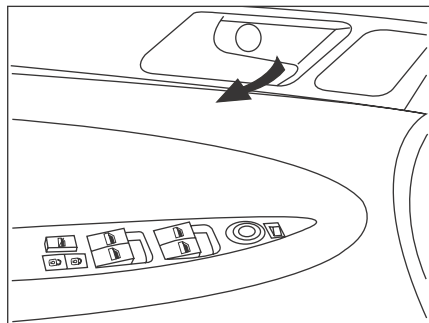

Opening the door inside

Opening the driver's door from inside will unlock the central locking mechanism when it is locked.

The inside handles for another three doors can only be used to open the door inside.

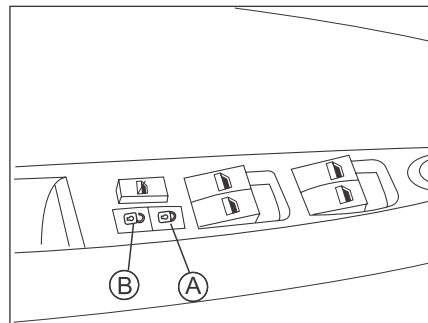

Locking/unlocking doors inside

Close all doors, press down the locking button (A) on the armrest at the left side of driver to lock doors and then the unlocking button (B) to unlock doors.



NOTE :

If the rear doors cannot be opened inside, the child safety latch may be locked. In this case, unlock the central locking mechanism and open the rear doors outside.
Never pull the handle forcibly to avoid any damage.



NOTE :

When the door is locked, it is forbidden to open the door inside and outside simultaneously, to avoid any damage to the door lock and the handle.

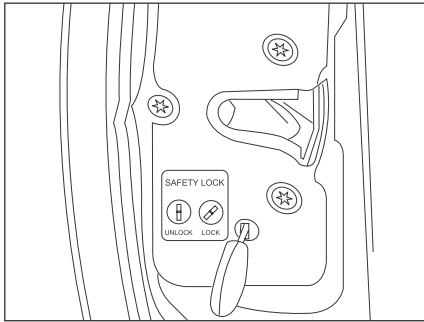

Child safety latch

The child safety lock is designed for preventing the child on the rear seat from opening the door inside accidentally. Each rear door is designed with a child safety latch. Use the key to rotate the red locking switch on the rear door frame to the locking position; after the door is closed, the child safety latch will function, and the door cannot be opened whether the vehicle is unlocked or not. To open the latched door, unlock the vehicle and then open the door outside. The notch will be vertical when the child safety lock is not in service.

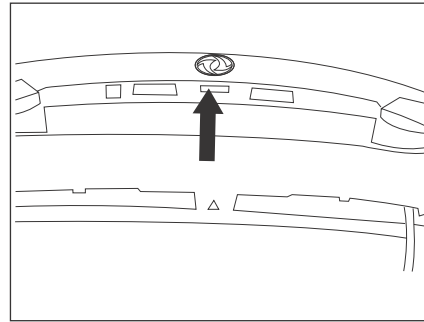

Trunk lid (liftgate)

There is one opening switch in the release handle of trunk lid. To open the trunk lid, unlock it, touch the opening switch and lift the handle up. To close the trunk lid, grip and pull the trunk lid edge downwards to 3/4 of its stroke, put your hands on the upper surface of the trunk lid and press it down to the limit.

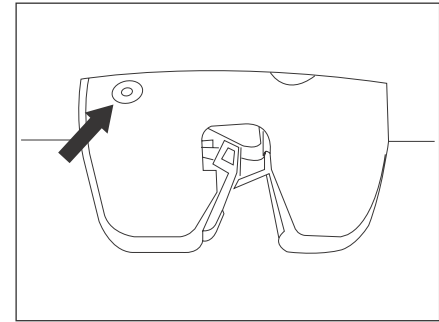

Spare opening mode for trunk lid (liftgate)

When the central locking mechanism is faulty or powers off, the spare mode can be applied to open the trunk lid (liftgate). Lay down the rear seat backrest and access to the trunk lid lock inside. Then insert a small and long metal bar into the spare mode activation hole above the lock body and toggle the lock hole rightwards (to the left side of vehicle) for unlocking.



NOTE : When closing the S30 trunk lid, pay attention not to make the hinge bracket held down by the luggage; when closing the H30 and H30 CROSS liftgate, be careful not to make the liftgate glass held down by the luggage; after closing, check whether the trunk lid and liftgate are closed exactly. Never leave the trunk lid and liftgate open during driving.

ENGINE HOOD OPENING/CLOSING

1

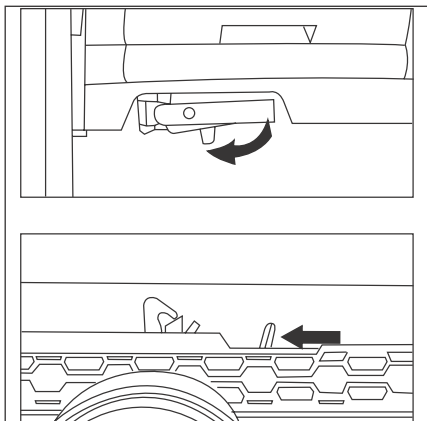

Opening the engine hood

Pull outwards the black handle at the left lower part of the instrument panel, unlock the inside lock of the engine hood and turn the safety hook handle at the middle of the engine hood to the left to open the engine hood.



NOTE :

Only when the vehicle is stopped can the inside handle of the engine hood be pulled.

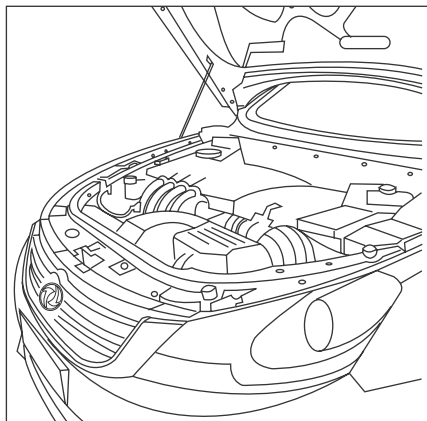

Strut

Put the strut in place after opening the engine hood. There is only one supporting position for the strut, as shown above.



NOTE :

Confirm that the strut top has been seated into the supporting hole of the engine hood. Do not open the engine hood against strong wind.

Closing the engine hood

Stably support the engine hood by hands and push it backwards slightly to make the strut detach from the supporting hole.

Then clamp tightly the strut after being seated, lay down the engine hood slowly to the bottom limit, and check that the engine hood is locked.



NOTE :

Do not lay down the engine hood forcibly but release it after it is placed to 3/4 of its stroke.

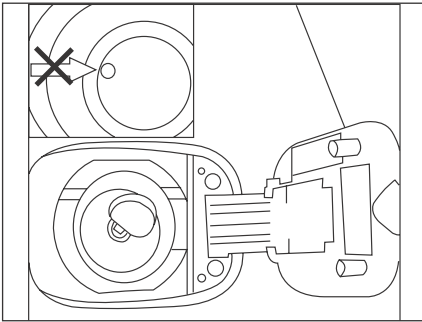

Fuel tank cap with lock

Open the fuel tank cap and insert the key into the fuel tank cap lock hole; rotate the key anticlockwise for 1/4 turns for opening and rotate it clockwise for 1/4 turns for locking.

Effective capacity of fuel tank: 51L The fuel tank cap must be replaced with one in same specification (sealing type) and with the same tooth profile as the key.



Warning

Do not press the left white venting valve in the fuel filler during refueling, to prevent the gasoline from entering the venting pipe and causing fuel leakage.

Fuel type

The label affixed on the fuel tank cap states the allowable fuel type.
Lead-free gasoline of 93# or above

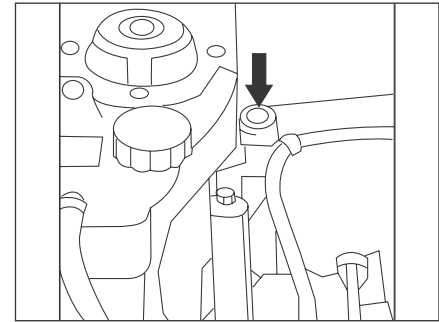

1

Fuel cut-off device

The fuel cut-off switch is installed beside the right front suspension of engine compartment.

When the vehicle suffers a strong collision from front or rear part, the fuel cut-off switch will disconnect the fuel supply circuit automatically.

To resume the fuel supply, press the upper part of the switch as shown.



NOTE :

When the fuel added is inconsistent with your engine system, before starting the engine, always drain out the fuel tank and clean the pipes, and then add appropriate fuel again.



Warning

Before resuming the fuel circuit, check the engine compartment for fuel leakage or odors and perform troubleshooting if necessary.

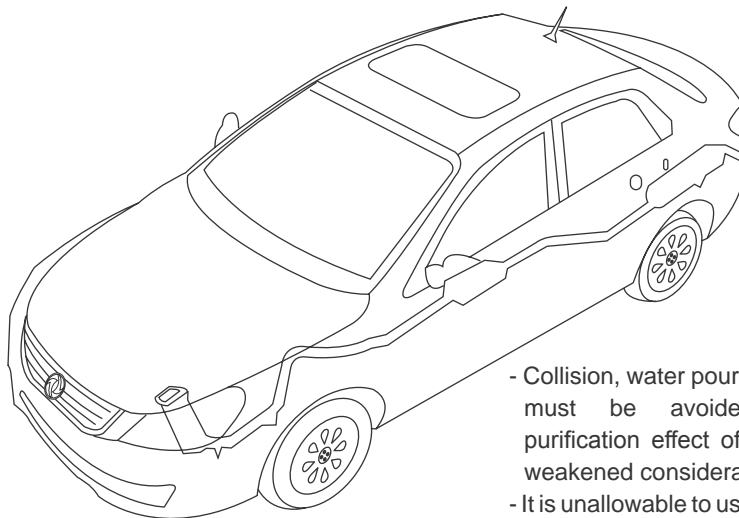

The three-way catalytic converter helps to substantially reduce the hazardous matters contained in the engine exhaust gas, contributing to the environmental protection.

Observe the following rules when using

the three-way catalytic converter:

- Qualified lead-free gasoline must be used, since the lead in the gasoline after combustion will, together with the exhaust gas, settle on the converter surface when being discharged, causing the converter ineffective earlier and the oxygen sensor ineffective due to lead poisoning;

- Collision, water pouring and immersion must be avoided, or else, the purification effect of converter will be weakened considerably;
- It is unallowable to use the fuel additives not approved by our company;
- It is unallowable to use the engine oil additives not approved by our company;
- The service life of the converter is closely related with the engine operation situation. Therefore, please do regular maintenance on the vehicle and have it repaired immediately if necessary.

The three-way catalytic converter may be damaged in case of improper engine running, therefore:

- Have it serviced regularly either at Dongfeng Franchise Store or IKCO authorised representatives according to the Warranty Manual;
- Have the engine checked either at Dongfeng Franchise Store or IKCO authorised representatives in case of difficult cold start;
- Have the engine checked either at Dongfeng Franchise Store or IKCO authorised representatives in case of unstable running;
- Refill the fuel immediately when the low fuel level warning lamp is lighted, because too low level will cause the fuel supply irregular and the engine running improper correspondingly;
- Do not start the engine by towing or pushing the vehicle;
- Do not force the engine to be started when the spark plug is faulty or the ignition coil is disconnected;
- After high-speed driving, run the engine at an idle speed before shutting it down;
- Since the working temperature of the three-way catalytic converter is extremely high, do not make any inflammables (such as dry grasses and combustible fluids) adhered on its casing surface to avoid fire disaster. Personnel shall not approach the exhaust pipe to avoid scalding.



Note:

It is prohibited to use the leaded gasoline, which will damage the threeway catalytic converter and cause the engine failure to work normally.

RUNNING-IN PERIOD

1

Running-in period

The following simple suggestions are provided within the first 1,500 km, to ensure the vehicle performance and prolong the vehicle service life.

- The vehicle should be started and run gently and steadily, the vehicle speed and engine speed should be appropriate, and the gear for driving should be selected reasonably.
- During the running-in period, the engine speed should not be higher than 4,000r/ min;
- Avoid emergency braking as far as possible;
- Do not tow other vehicles within the first 1,500km.

For the gasoline engine, from 1,500 km, increase the vehicle speed and perform acceleration gradually till up to the appropriate rotation speed. In general, the engine will run at the best performance from 3,000 km.

For a new vehicle, after traveling for three months or 2,500 km (whichever comes first), have it undergone the runningin period inspection either at Dongfeng Franchise Store or IKCO authorised representatives.



Note:

Check the engine oil level more frequently during the running-in period, because the fuel consumption may be relatively higher in this period of time.

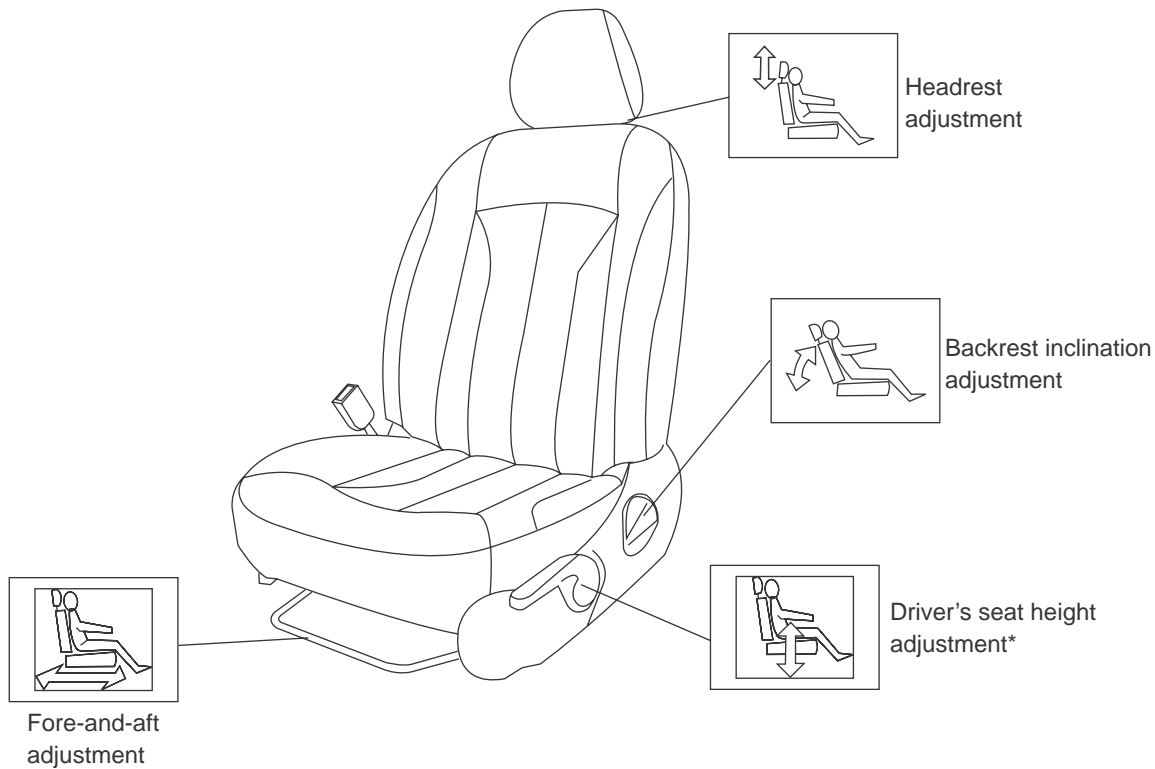

FRONT SEAT

1

Headrest adjustment



Press the button beside the headrest rod hole to adjust the headrest to the appropriate height which can be achieved when the headrest middle is level with the ear middle. To remove the headrest, press this button and lift the headrest up.



Note:

Do not drive the vehicle without headrest.



Note:

Do not press the headrest downwards directly without pressing down the adjusting button, or else, the headrest adjustment mechanism will be damaged.

Backrest inclination adjustment



Lift up the adjusting handle to adjust the backrest inclination appropriately. Afterwards, press down the adjusting handle and rotate the backrest back and forth to lock the adjusting handle locking mechanism.

Driver's seat height adjustment*



Lift up the handle to raise seat and press down the handle to lower the seat within a range of 40mm at the most respectively.

Fore-and-aft adjustment



Lift up the control handle to adjust the seat to desired position. Then release the handle and swing the seat back and forth twice, until the locking mechanism is confirmed to be locked and the seat cannot be moved. The fore-andaft adjustment range is 220mm at the most.



Warning:

- For driving safety, adjust the front seat when the vehicle is stopped.
- Do not drive the vehicle without headrest.

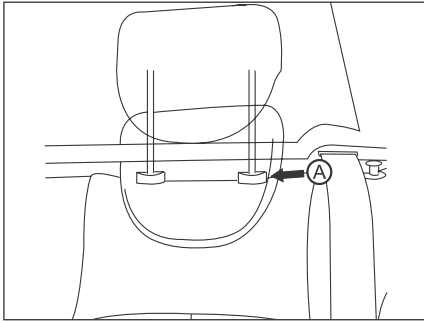

Rear headrest

The rear headrest is removable and subject to high/low position adjustment.

Low position: The position when the rear seat is not taken by passenger.

High position: When the rear seats (incl. the frontward child seat) are taken by passengers, lift up the headrest to a fixed position.

Lift up the headrest from low position to high position.

When it is required to lower the rear headrest, press and hold the locking button (A) and press the headrest downwards.

When it is required to take off the rear headrest, adjust it to the high position, press and hold the locking button (A) and then lift off the rear headrest upwards.



Warning:

During driving, do not take off the headrest used to protect the neck.

REAR SEAT (S30)

1

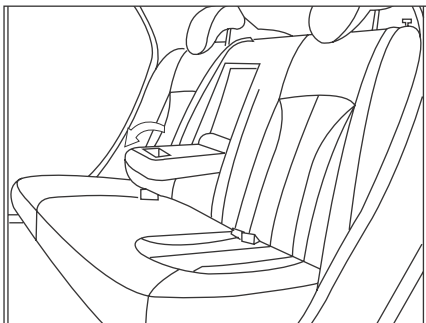

Rear seat

The rear seat backrest is of one-piece and equipped with two headrests. It can be folded frontwards as a whole.

Rear seat centre armrest*

The middle part of the rear seat backrest can be lowered down as the center armrest with two cup holders.



Note:

The cup placed into the cup holder shall be covered with sealing cap.

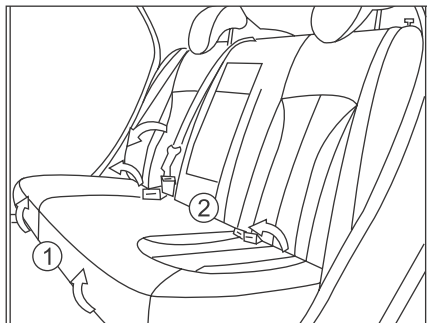

Rear seat cushion tilting

The seat cushion is tiltable. Lift up the rear seat cushion front ① and back ② gently in sequence to tilt the cushion towards the front seat backrest.



Note:

After resetting the cushion to the normal position, pull out the four buckles of the safety belt and put them on the cushion.

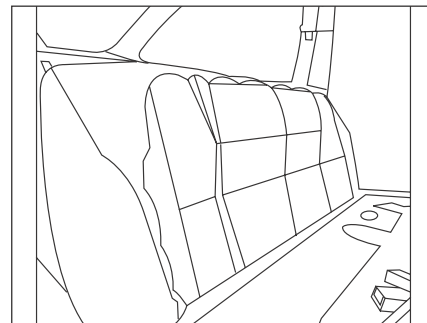

With rear seat cushion tilted

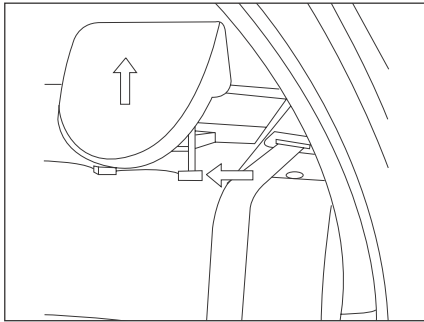

Rear seat full-folding

Tilt the rear seat cushion and take off the rear headrest.

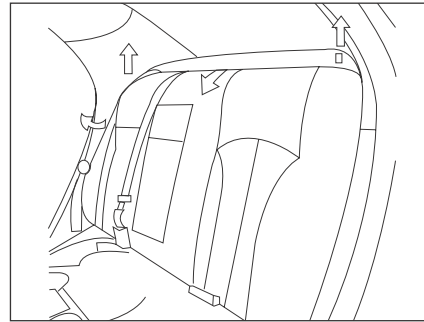

Press the buckle of lower anchorage of the middle seat belt to detach the latch plate of belt, and make the belt retracted fully. Then move the side belt to two sides. Afterwards, lift up the two pull buttons on the rear seat backrest and tilt the backrest backwards, then the rear seat can be folded.

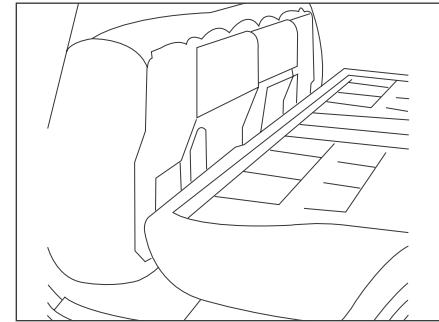

After folding the rear seat, the cabin is connected with trunk, enlarging the space.



Note:

It is not allowed to fold the rear seat before the cushion is tilted, so as to avoid the detachment of support at the lower part of backrest.



Note:

When resetting the rear seat backrest, always place the side belt at two sides smoothly, pull out the middle seat belt and insert the lower latch plate into the corresponding buckle. After restoring the backrest to the normal position, it is a must to check that it has been locked reliably, or else, the articles in the trunk may enter into the passenger compartment and hurt passengers in case of emergency braking or collision.

REAR SEAT (H30, H30 CROSS)

1

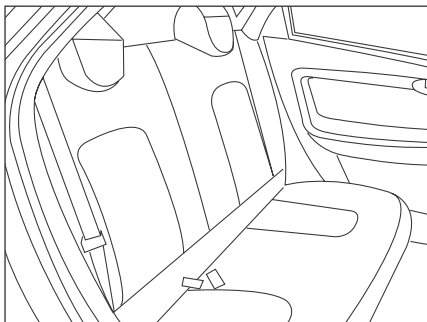

Backrest folding

The 6/4 split-type seat backrest can be partially or wholly folded according to the actual requirements.

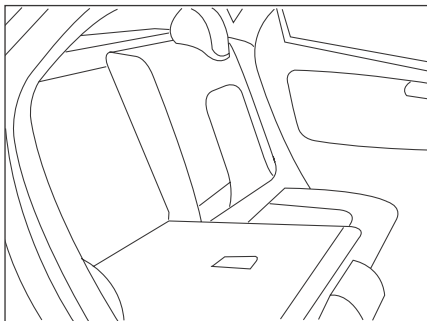

Fold the right backrest of rear seat

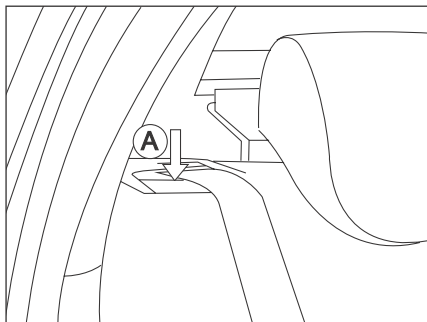

There is one button at the left top and right top of the backrest respectively. Detach the latch plate of the middle seat belt, fully retract the belt and push the side belt aside. Press down the button forcibly to fold the backrest forwards.

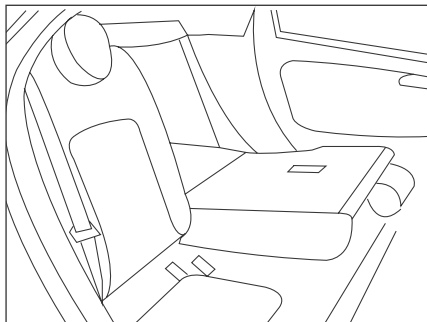

Backrest resetting

Place the seat belt at two sides and push the seat backrest upwards until it is locked reliably.



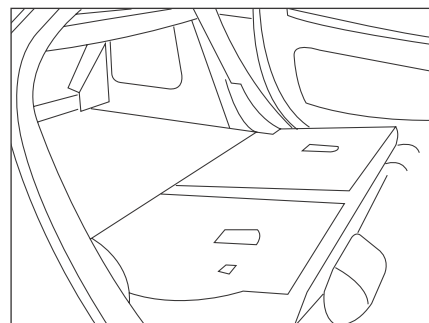

Note:

When resetting the rear seat backrest, always place the side belt at two sides smoothly, pull out the middle seat belt and insert the lower latch plate into the corresponding buckle. After restoring the backrest to the normal position, it is a must to check that the backrest has been locked reliably, or else, the articles in the trunk may enter into the passenger compartment and hurt passengers in case of emergency braking or collision.

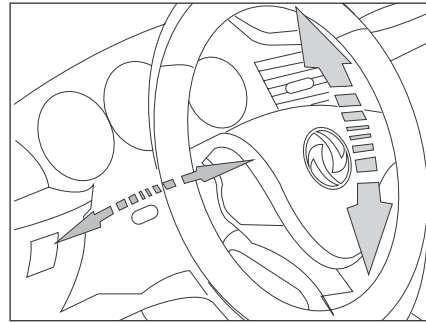
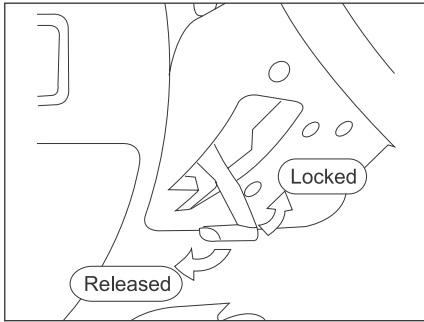

After the rear seat backrest has been folded fully, the trunk space will be enlarged.





Warning:
It is prohibited to adjust the steering wheel position during driving.

Steering wheel position adjustment

- When the vehicle is stopped, adjust the seat to the appropriate position (see Page 30);
- Push the steering wheel adjusting handle down to the limit and then release it for locking;
- Move the steering wheel to make it towards your front chest instead of face. Ensure that all instruments and indicator lamps on the instrument panel are visible to you;
- The steering wheel angle can be adjusted by tensioning back and forth as well as moving up and down; after appropriate adjustment, pull the adjusting handle upwards to the top

- limit to lock the steering wheel;
- Try to move the steering wheel back and forth as well as up and down to confirm that the steering wheel has been tightly locked in place.

Note:
When the steering wheel is locked, it is normal that the steering wheel will move axially slightly when being forcibly pulled or pressed. However, please do not try like that.

DRIVING POSITION

1

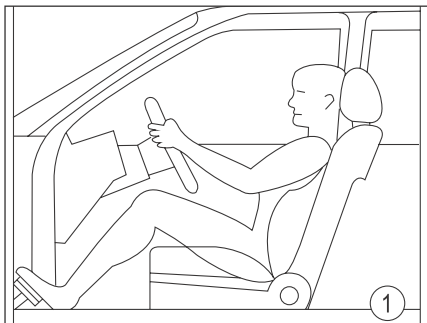

Illustrated driving position:

- ① Correct
- ② Incorrect (too close)
- ③ Incorrect (too far)

Recommendations on adjustment of driving position

Seat adjustment (see Page 22)

Fore-and-aft position:

- Adjust the seat for the purpose of depressing the clutch pedal to the limit comfortably.
- Keep the body in driving state, with the right foot depressing the accelerator pedal and the left foot on the footrest.
- The buttocks is supported by the seat cushion completely.

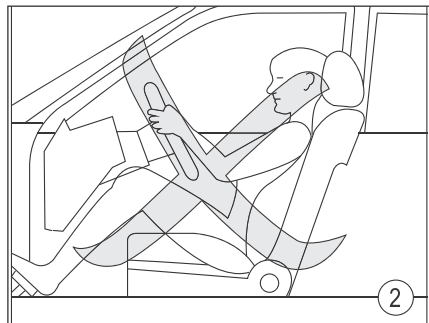

Backrest inclination

Adjust the backrest to enable the driver's back to lean against the seat in whole height comfortably. To ensure the effectiveness of safety belt, do not incline the backrest excessively.

Headrest: To give full play to its safety protection, the headrest shall be as close to the head top as possible.

Steering wheel position adjustment (Page 29)

Adjust the steering wheel as follows: grip the steering wheel with two hands at the 9 o'clock and 3 o'clock positions respectively as well as the arm bending slightly, and adjust the steering wheel

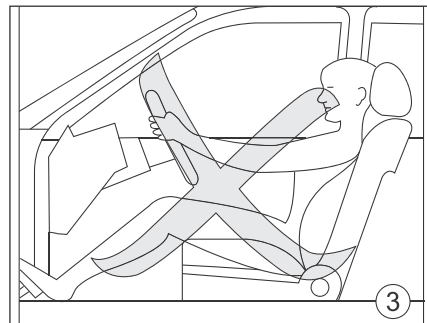

height to make it not obstruct the instrument observation.

Safety belt adjustment (see Page 44)

Fasten the safety belt and make it pass through the middle part of the shoulder width.

Position the footrest mat at the driver's side correctly and prevent it from sliding; do not stack up two layers of liners to avoid interfering the pedal operation.



Warning:

It is prohibited to adjust the seat during driving.

Airbag system

The airbag system consists of the following units:

- Sensors and control units;
- Front airbag for driver;
- Front airbag for right front passenger*;
- Side airbag*;
-  Airbag warning lamp.

Airbag warning lamp is used to warn the driver that the airbag, sensor or seat belt pre-tensioner is risky possibly. After the ignition switch is turned to M position, the warning lamp will flash for 6 times and then go out, indicating that the system works normally.

If the indicator lamp is lighted at other moments or fails to be lighted in any cases, please have the system checked either by the designated Dongfeng Franchise Store or IKCO authorised representatives for the following abnormalities:

- ① The airbag warning lamp will be off after the ignition switch is turned to M position;
- ② The warning lamp flashes for 6 times and then stays on;
- ③ The indicator lamp is on or on/off alternatively during driving.



Warning:

- If the airbag warning lamp is ignored, serious casualty will be resulted once the airbag system or safety belt pre tensioner works abnormally.
- Airbag is only a supplementary protection for safety belt. Please wear the safety belt properly at any time during driving.
- Replacement of airbag system: After the airbag inflates or the vehicle has been in service for 10 years, it is a must to have your whole set of airbag system replaced either at Dongfeng Franchise Store or IKCO authorised representatives to ensure its normal operation.

AIRBAG

1

Front airbag

The airbag, as a supplementary protection for safety belt, is used to create a buffering bag between the front passenger and the instrument panel in case of strong front collision, so as to mitigate the forward impact to passenger and the injury caused to head and chest. If the safety belt is not fastened, during the slight front collision, side or rear collision or vehicle rollover, the front airbag will not inflate since the conditions are not satisfied. At this time, only the safety belt will provide safety protection. The inflation of the airbag is dependent on the deceleration of front collision (the deceleration is in proportion to the collision intensity) and has no direct relationship with the vehicle deformation and extent of damage after collision.

Front airbag -working

In case of violent front collision, the airbag will swell immediately and deploy from the steering wheel middle part or the instrument panel in front of right front passenger to buffer the forward impact to the front passengers, and then deflate quickly.

The whole process is completed in an extremely short period, approximately 1/10 s.



Note:

When the airbag inflates, all doors will be unlocked to facilitate the rescue by opening the door outside.



Warning:

When the airbag inflates, some parts of the airbag system will get hot. Do not touch them to avoid scalding.

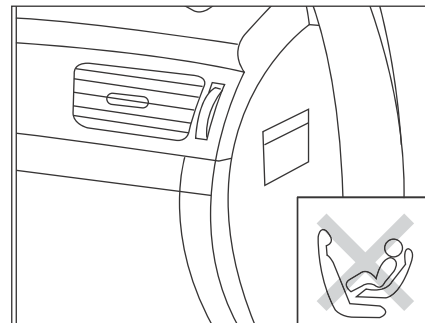

Application prohibited

The vehicle is installed with available front airbag for front passenger. Do not install child seat on the front passenger seat, since the airbag will hurt the child once inflated.

Read the warning notice marked on the right sun visor carefully.



Danger:

It is prohibited to apply child seat on the front passenger seat to avoid injury.

Front airbag – basic knowledge

1. Inflating conditions:

The airbag inflating command will be sent when the vehicle collision angle and intensity detected by the deceleration sensor satisfy the inflating condition, which is supported by the following three conditions:

- The power is on. If the vehicle is powered off, the airbag inflating command will fail to be generated and sent;
- The vehicle collision direction is in line with the direction of deceleration detected by sensor;
- The deceleration detected by sensor meets the inflating condition.

2. The front airbag will not inflate in the following traffic accidents:

- Rear-end collision;
- Vehicle side turn or rollover;
- Front collision with such cylindrical objects as telegraph pole or trees;
- Entering under the container wagon or large vehicle;
- Collision with guardrail or other vehicles in left/right front;
- Colliding the rear end of other vehicles in front;
- Collision after the front airbag has been activated once;
- The front airbag system was technically damaged during the previous repair.

**Note:**

The national certified collision test conditions are that the front airbag will deploy when the vehicle at the speed of 50km/h collides with a non-deformable and irremovable obstacle.

AIRBAG

1

Front airbag – Illustration for possible non-inflating

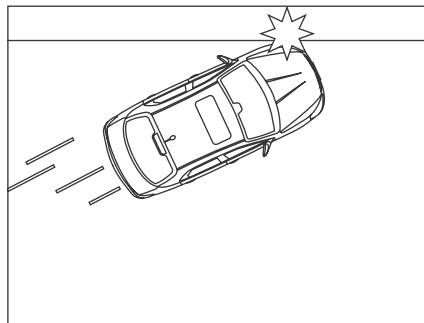
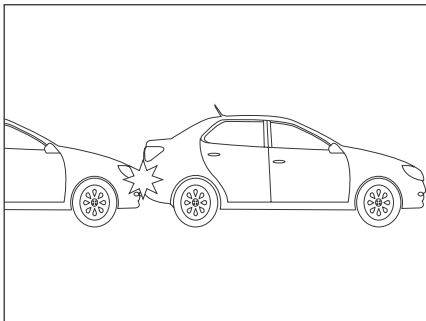

Collision with guardrail or other vehicles in left / right front

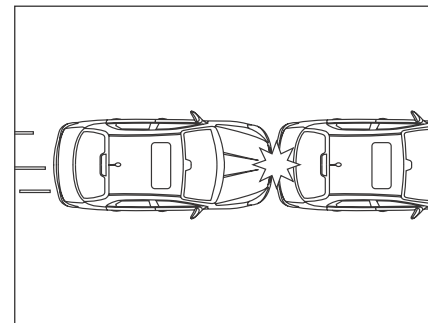

Collision after the front airbag has been activated once

Rear-end collision

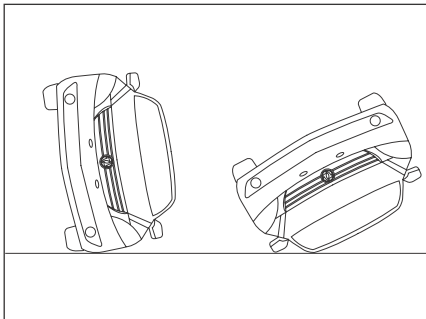

Side turn or rollover

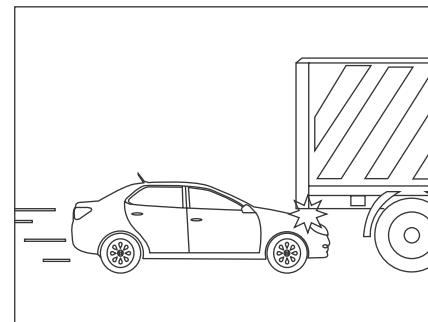

Entering under the container wagon or large vehicle

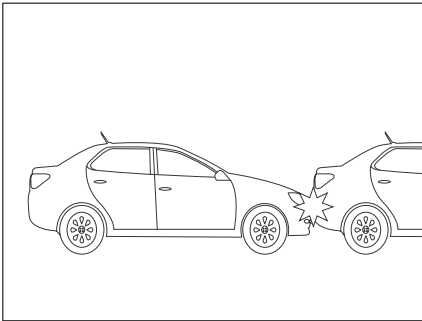

Collision with the rear end of vehicle running in the same direction

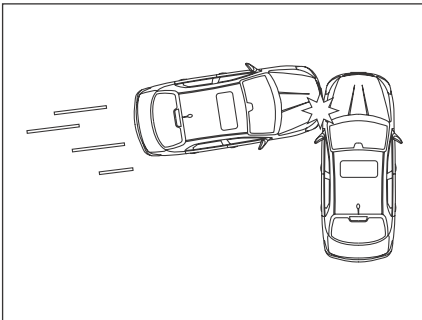

Side collision to engine compartment or trunk lid

Front airbag - precautions

- Always fasten the safety belt well;
- Do not fix or stick any article on the steering wheel middle airbag cap and instrument panel within the area of passenger airbag, because it may impede the normal airbag working or hurt people during airbag inflating;
- Do not place any article between human body and airbag;
- Do not grip the steering wheel spokes or place your hand on the middle airbag cap during driving;
- Do not smoke during driving (you may be scalded or injured by lighted cigarette during airbag inflating);
- Do not put the feet on the instrument panel when the vehicle is moving;
- It is recommended to make the child take the rear seat with the child restraints applied.

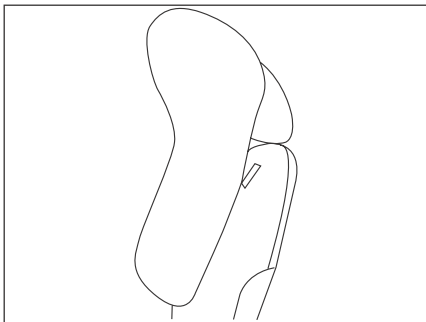

Side airbag*

The side airbag is designed to function in case of serious side collision; the airbag on the collided side will swell during collision.

The side airbag is used to provide an airbag between the front occupant (driver or front passenger) and the door to mitigate the injury to the head and upper body.

The airbag will not deploy for auxiliary safety protection in case of slight side collision or scratch, rear/front collision or rollover.

Side airbag - working

In case of violent side collision, the airbag on the collided side will inflate and swell and then deploy from the designated tear on the front seat backrest, so as to mitigate the impact to the front occupant towards the door side; afterwards, the airbag will deflate quickly.

The whole process is completed in an extremely short period, approximately 1/10s.



Warning:

For seat backrest equipped with side airbag, it is prohibited to install inappropriate seat cover since it will impede the airbag extension.

Why should the safety belt be fastened?

It is proved that the safety belt can provide proper protection in case of accidents, therefore, the national regulations specify that the safety belt shall be fastened.

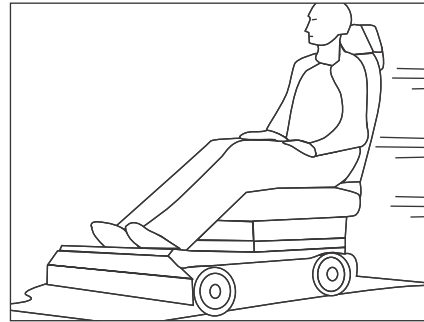

Taking a simplest vehicle as an example, someone takes the seat without fastening the safety belt.

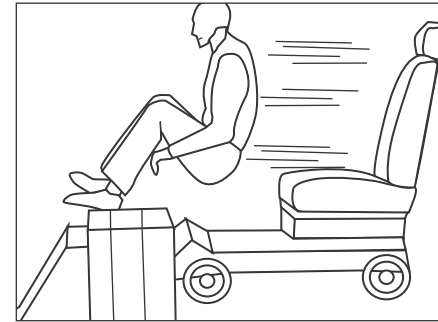

The vehicle is driven at a certain speed and decelerated suddenly when coming across an obstacle. At this time, the passenger on the vehicle will move against the vehicle under the inertia and fly off forwards, causing personal injury.

**Note:**

Before each driving, wear the safety belt well even in urban traffic.

This regulation applies to the rear seat as well.

Whether the safety belt motion (including smooth extraction, quick locking by pulling, reliable buckle release/clipping and others) is correct or not means a lot to its protection effect.

SAFETY BELT

1



The passenger not wearing the safety belt is not “bundled” up with the vehicle. When the vehicle decelerates suddenly in front of obstacles or suffers a front collision, the passenger will keep moving at the speed before acceleration or collision and bump into such interior components as steering wheel, instrument panel, front windshield or even be thrown out of the vehicle, endangering the life.

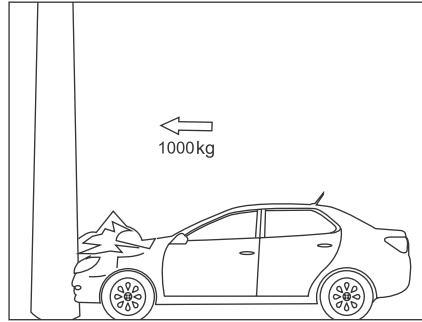

The vehicle speed is the most significant factor during collision. For instance, if the vehicle speed increases to 50km/h from 25km/h, i.e. doubled, the kinetic energy will be quadrupled. When the vehicle runs at the speed from 30km/h to 50km/h, the force applied on human body during accident is easy to surpass 10,000 N, equal to a mass of 1t (1,000kg).

If the passenger does not wear the safety belt, all of his/her kinetic energy during the collision accident can only be absorbed by his/her body and the collided objects. With the increase of vehicle speed, the force exerted on human body will be geometrically multiplied against the vehicle speed. It means that, if the vehicle speed is doubled, the impact on human body will be quadrupled.

However, if the safety belt is fastened, the kinetic energy will be damped and mitigated by the safety belt, substantially reducing the force applied on the human body and transferring the force to the body part with strong bearing capacity, thus reducing the risk of personal injury. Some people think that the body can be supported by hand during slight collision. It is absolutely wrong. The force applied on human body can never be supported despite a low collision speed.

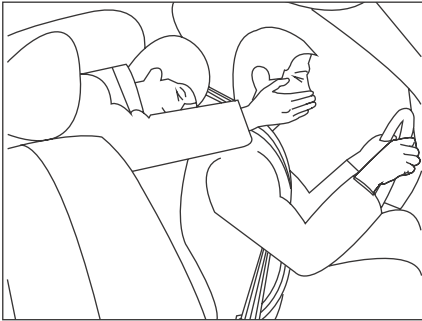

It is important for passengers on the rear seats to wear safety belt, because they would be thrown away in the vehicle out of control in case of accidents. The passenger on rear seat not wearing safety belt will endanger not only himself/ herself but also the passengers on front seats.



Protection by safety belt

Wearing safety belt properly can keep the passenger at the correct seat position and synchronize the passenger with the vehicle during acceleration. The safety belt in deceleration will significantly reduce the kinetic energy of human body and mitigate the injury due to uncontrolled motion. This explains why the safety belt is so important.

The kinetic energy can be well absorbed by the safety belt; therefore, passengers will benefit a lot for protection if the safety belt is worn correctly. Other front buffer mechanisms and supplementary safety facilities including airbag system can also absorb the kinetic energy and mitigate passenger's injury.

The example given only describes the situation of front collision. Those physical principles, however, apply to other types of collisions as well.

Thus, please wear properly the safety belt before each driving, even "driving for a corner". Pay attention to urging your passengers to wear the safety belt. The accident statistics prove that wearing the safety belt as per the regulations will lower the risk of injury and enhance the possibility of survival. The relevant regulations specify that the safety belt shall be fastened.

SAFETY BELT

1

Misunderstandings on application of safety belt

Will you be tripped in the car if the safety belt is fastened?

You will not be tripped in the vehicle regardless of the fastening of safety belt. If the safety belt is fastened, you have higher opportunity to keep sober after accident compared with the situation without fastening the safety belt, and you can release the safety belt buckle and leave the vehicle.

Why the safety belt shall be fastened since the vehicle has been provided with airbag?

Airbag is just a supplementary system and can only works in combination with the safety belt instead of as a substitute. The operation of airbag system requires that the safety belt must be used. Even if you take a vehicle equipped with airbag, the safety belt buckle shall be clipped to obtain reliable safety protection, which means a lot for front collision and means more for side collision or other kinds of collisions.

Why the safety belt shall be fastened if I can drive the vehicle safely?

In case of traffic accidents even not due to your fault, you and your passengers will be injured. Even though you can drive the vehicle safely, your safety still cannot be secured when coming across the accidents out of your control, which is similar to unsafe driving. So, occupants shall apply the safety belt at any time.



- The safety belt shall be kept clean. If contaminated, its automatic retraction function will be impeded.
- The guiding device for latch plate shall not be barred by papers or similar products, or else, the latch plate cannot be engaged correctly.
- Check the safety belt at any time. If the safety belt webbing, connections, automatic retraction device or locking device is damaged, always have the safety belt replaced either at Dongfeng Franchise Store or IKCO authorised representatives.
- The safety belt should not be removed or modified in any method or manner. Do not try to repair the safety belt by

yourself.

- The safety belt used during accidents and deformed due to tensioning must be replaced either at Dongfeng Franchise Store or IKCO authorised representatives. In addition, check the safety belt regularly in any other cases.
- The safety belt shall not pass through the sharp or fragile matters (such as glasses and ball-point pen), or else, personal injury will be caused.
- The excessively loose cloth (such as overcoat out of the male sack coat) will impede the function of safety belt. The protection of safety belt can play to the full as only as the correct seat

position is taken.

- Always put your feet on the footrest space during driving instead of on instrument panel or seat cushion in any case.



Warning:

- Always fasten your safety belt before each driving. This requirement is equally applied to the rear seats.
- The protection of safety belt can play to the full as long as the belt is fastened correctly.
- Ensure that the safety belt is fastened as per the description in this chapter. Wearing safety belt incorrectly will significantly increase the risk of injury during accident.
- The safety belt cannot be clamped, bent or abraded on the sharp part.
- Do not share the same safety belt with another people (even child). Such a kind of safety belt application will endanger the child sitting on your knees.

SAFETY BELT

1

How to fasten the safety belt correctly Adult

The current safety belt is only applicable to adult in common height. To ensure the safety of each occupant, please follow the specific precautions for the application of safety belt for child and those regulations for infants.

Front seat belt

For lap-shoulder belt (three-point belt), move the headrest upwards or downwards to make the headrest middle parallel to the ear middle, which can reduce the possibility of neck injury during collision.

Safety belt locking

1. Close and lock the door.
2. Adjust the seat to make the upper body vertical in sitting position.

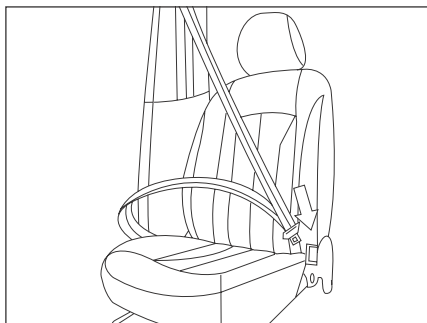

3. Take the latch plate in hand and slowly pull the safety belt around your body without twisting it. The shoulder belt may be locked if pulled too fast. If so, retract the safety belt slowly to unlock it and then pull the safety belt around your body relatively slowly.

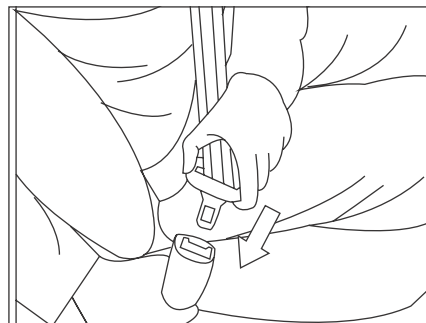

4. Insert the latch plate into the buckle until a “click” is heard. Pull the latch plate once to confirm for firmness.

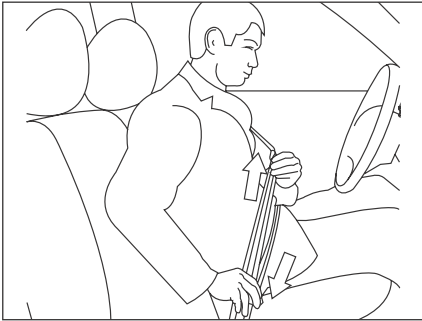

5. Pull the safety belt latch plate end downwards and the shoulder belt upwards at the same time to tension the lap belt.

**Note:**

During emergency braking, vehicle collision or quick safety belt pulling, the safety belt may be seized during extension. Retract the safety belt a little bit to reset it for normal extraction.

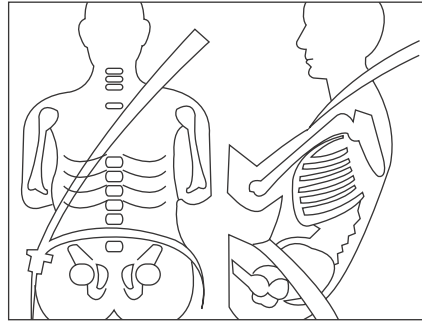

The lap belt should be fastened a little bit low and just in contact with the thigh. Therefore, in case of collision, the force will be exerted on the relatively sturdy pelvis and keep the body from sliding down to the part below the lap belt. If your body slides down below the lap belt, you will be injured seriously or even killed. The shoulder belt should pass through the shoulder and cross over the chest, since it is the most ideal part to bear the restraint force of the safety belt.

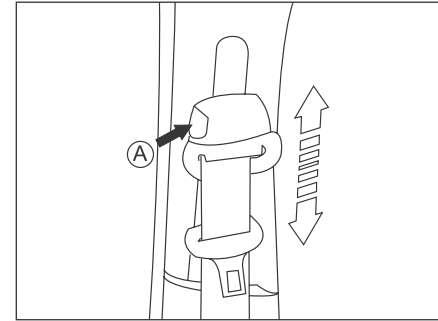
**Safety belt height adjustment**

The front passenger can adjust the height of safety belt anchorage according to his/her body shape. There are five types of positioning height for the upper anchorage of safety belt. Move the anchorage directly to raise it. For lowering it down, press down the locking button (A) to make the safety belt upper pivot slide to the appropriate position and then release the button. And then, push the upper pivot up and down to confirm for locking or not.

**Warning:**

The front passenger should adjust the safety belt only when the vehicle is stopped.

SAFETY BELT

1

Pretensioned front seat belt

The front seat is provided with the height adjustable safety belt with pretensioner and retractor.

The pretensioner is designed to tension the safety belt in case of serious front collision, thus keeping the occupant's body closely against the seat and improving the protection effectiveness.

During collision and emergency braking, the safety belt can prevent you from being thrown out of the vehicle. Therefore, the relevant regulation requires the passenger (incl. pregnant women) to fasten the safety belt regardless of the driving distance.



Note:

Harmless light smoke and sound will be produced when you open the pretensioner, which is caused by system internal core detonation.

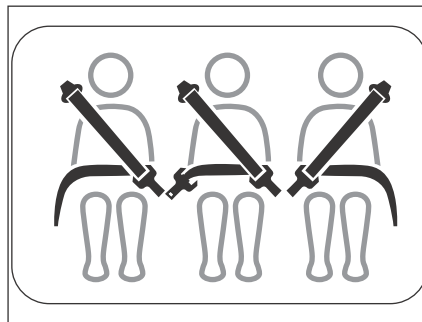

The fastening method for the two side safety belts of rear seats is the same with that of the front seat belt. When applying the middle rear seat belt, pull it out of the shelf and insert the end latch plate into the buckle on the right lower part of the middle seat until a "click" is heard. Pull the latch plate once to confirm for firmness.

Afterwards, move the middle sliding latch plate on the safety belt to make the shoulder belt and the lap belt pass through the appropriate body part (similar to the front seat), and then insert the middle sliding latch plate into the buckle on the left lower part of the middle seat until a "click" is heard. Pull the latch plate once to confirm for firmness. When leaving the seat, press down the red button on the buckle on the right lower part once to release the safety belt restraint. Press the button again to retract the safety belt.

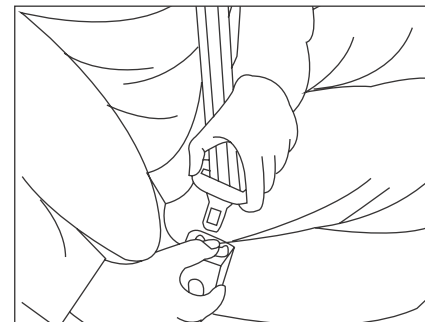

Release of safety belt

Press down the red button on the buckle to release the safety belt. The safety belt shall be retracted to the original position. Confirm that the safety belt is properly placed before closing the door to avoid impeding the door closing. The safety belt and vehicle may be damaged if the safety belt is squeezed during door closing.



Warning:

Replacement of pretensioner detonation system: The pretensioner detonation system must be replaced at the dealers after the detonation or the vehicle has been in service for ten years. Any servicing or inspection of pretensioner can only be done at the dealers. Any servicing not in strict accordance with the relevant regulations will cause system work failure or improper opening, thus causing personal injury.

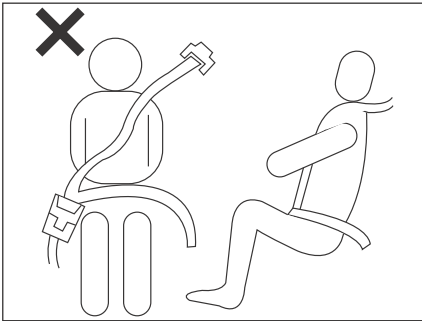

The safety belt cannot function for protection if the shoulder belt is too loose.

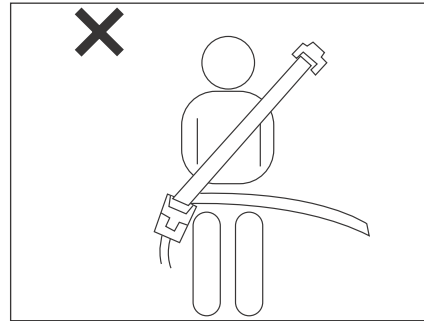

The seating position is too far away from the safety belt latch plate.

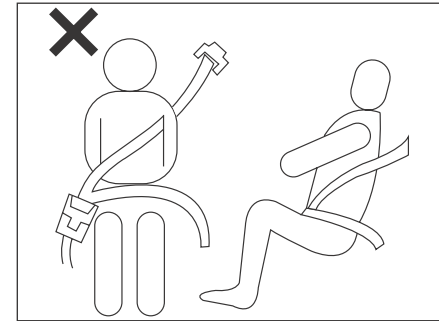

The shoulder belt should not pass through under the arm but above the shoulder in any cases.



Warning:

If the safety belt is fastened too loosely, you may be injured seriously, since you may move forward substantially in case of vehicle collision, aggravating the injury.

The shoulder belt should fit closely against your middle shoulder. The safety belt is so designed that it can be automatically locked during emergency braking and traffic accident, preventing you from any injury.



Warning:

If the position of the safety belt latch plate is incorrect as shown, you may be injured seriously, since the safety belt may move upwards to your belly during the vehicle collision, thus making its force applied on the waist instead of pelvis and causing serious internal injury as well. Therefore, the safety belt latch plate shall be as close to your body as possible.



Warning:

If the safety belt passes through under the arm, you may be injured seriously, since your body may move forwards a lot during vehicle collision, increasing the possibility of head and neck injury and making most of safety belt force applied on the rib. After all, the rib is not as sturdy as the scapula. Besides, your internal organs such as liver and spleen may get hurt.

SAFETY BELT

1

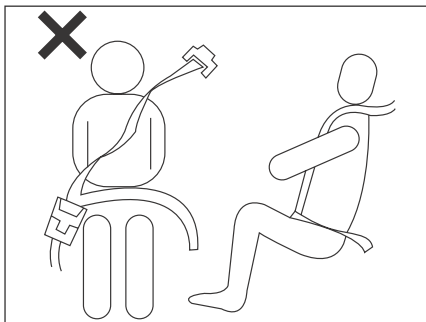

The safety belt should not be twisted when passing through the body.

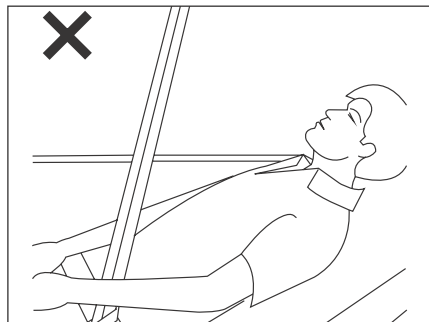

Do not fully incline the seat backrest during driving.



Warning:

You may be seriously injured if the safety belt is twisted, since the twisted belt cannot bear your impact in the whole width during vehicle collision.

If so, smoothen the safety belt to make it work correctly. If the safety belt cannot be smoothened, contact either Dongfeng Franchise Store or IKCO authorised representatives.



Warning:

It is dangerous for you to lean against the inclined seat backrest during driving, because the safety belt, even fastened to keep the body, will fail to function if you lie obliquely.

The shoulder belt cannot function as well since it does not fit against your upper body but the front part. If the collision happened, your body will slide into the safety belt, making your neck hinged or causing other injuries.

Therefore, you may be seriously injured or even killed.

The lap belt does not function at all in this case. If the collision happened, the lap belt may slide over your belly and exert force on the belly instead of pelvis, causing serious internal injury.

The seat backrest must be vertical during driving to function for protection.

The whole back should lean against the backrest and the safety belt should be fastened correctly.

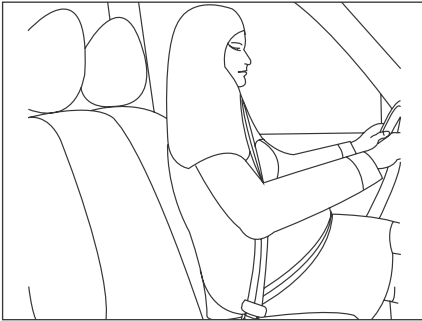

Application of safety belt for pregnant women

The safety belt serves for all of us, including the pregnant women. As other passengers, if the pregnant woman does not wear the safety belt, she is more likely to be injured seriously. The safety belt for the pregnant woman shall be of threepoint type (three-point anchorage) with the lap belt fastened as low as possible, i.e. lower than the whole round pregnant part.

If fastened correctly, the safety belt can reduce the possibility of hurting the fetus in case of vehicle collision. For pregnant women and other people as well, wearing the safety belt correctly is

the key to ensuring effectiveness of the safety belt.

Application of safety belt for children

The accident statistics prove that it is relatively safer to ask the older children (at an age of 10-15) take the rear seat and fasten the safety belt.

- The children not wearing the safety belt may be thrown out of the vehicle during the collision.
- The children not wearing safety belt may bump into other passengers wearing the safety belt.

Apply the shoulder belt at the children's shoulder to make the children's upper body restrained during the vehicle collision.

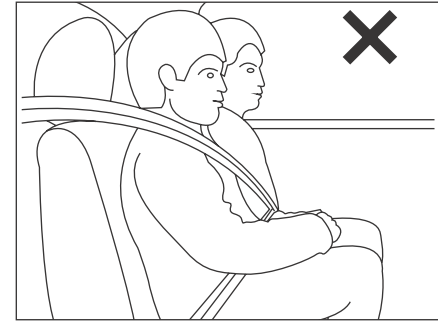

1



Warning:

Never let two children share the same safety belt as shown, since the impact cannot be transferred normally in this case. During vehicle collision, two children will be crowded together and seriously injured. Each safety belt is exclusive for one person only.

SAFETY BELT

1

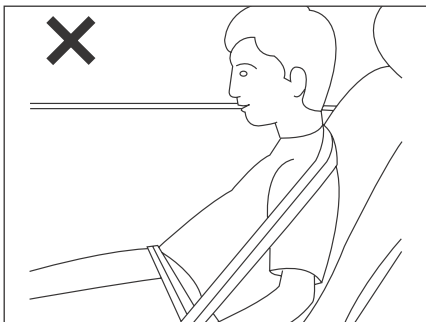

The lap belt should be fastened as low as possible, fit closely against the hip and just approach the thigh, regardless of the seating position of the child. In this way, the action force can be transferred to the child's pelvis in case of vehicle collision.



Warning:

Never fasten the safety belt as shown! The child as shown takes a seat provided with lap-shoulder belt but with the shoulder belt located at the back of shoulder. In this case, during the vehicle collision, the child may slide under the safety belt to make the action force just exerted on the child belly, possibly causing serious casualties.

When a child takes the vehicle

To ensure safety, please understand and consider the following requirements:

- The child must take the safety seat.
- The child lighter than 9kg shall be seated with “back towards the driving direction”. It is recommended to apply this seating manner for a long period (until the child is 2-3 years old).

Safest seating position for children:

Rear seat. Even if a rearward child seat is equipped, you shall make the child take a rear seat.

- Do not make the child sit on the knees of the front passenger in any cases (since the child may be thrown to the instrument panel or windshield in case of vehicle collision).
- Do not make the child stay at the position between two front seats to avoid being thrown out during emergency braking or vehicle collision.
- Both rear doors are equipped with the “child safety latch”. If the function is activated, only after unlocking the central locking can the rear door be opened outside.

- Do not leave the child alone in the vehicle exposed to the sun.
- Ensure that there is no danger and watch out the traffic before opening the door.
- Take off the key and apply the parking brake before leaving the vehicle.
- Do not leave the key on the vehicle, since the child may start the vehicle with the key by accident, and thus causing dangers. The key may also be locked in the vehicle by accidentally pressing down the remote controller or the central locking button, making you unable to open the door outside.

The body structure of a child is different from that of an adult: the head-body specific gravity of child is different from that of the adult before the child becomes 7-8 years old. During the sudden deceleration or violent vehicle collision, serious cervical trauma may be caused for children since their muscle on the neck is relatively weak and the bones are fragile.

Only the child up to 10 years old or 1.35m high can be seated in the vehicle

without child restraints. But the safety belt is still a must.

Child should be placed on the rear seat:

The vehicle collision statistics prove that it is much safer to place the child on the rear seat instead of front seat regardless of the age and height.

During vehicle collision or emergency braking, the child on the rear seat is unlikely to be injured by the hard articles inside and the inflated airbag.

**Warning:**

It is prohibited to place child seat on the front seat, or else, serious casualties may be caused.

CHILD SAFETY

1

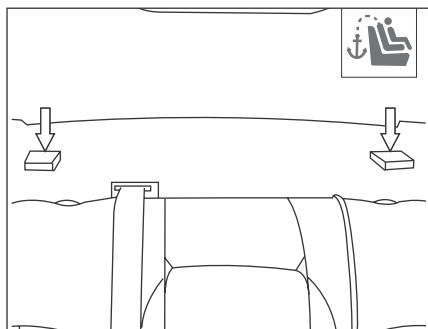

ISO FIX child safety seat anchorage

On S30 model, the child seat upper anchorage supports are located on two sides of the rear shelf; four lower anchorage supports for child seat are provided under the ISO FIX mark on the rear seat backrest.

The anchorage support is used to install the top strap of the child safety seat.

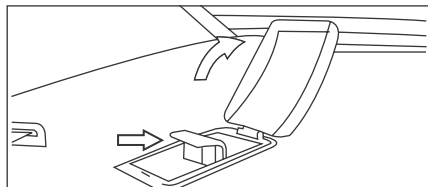

Flip up the anchorage support cover backwards to expose the support.

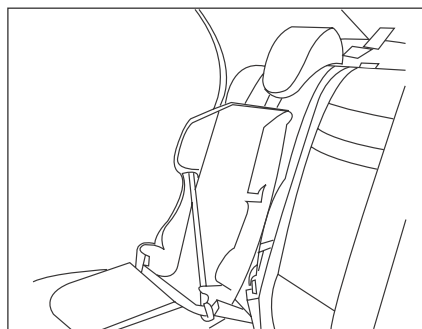

After adjusting the rear seat headrest height, have the top strap of the child safety seat threaded through the middle part between two support legs of the rear headrest and hook it firmly to the anchorage supports; then tension the top strap and secure the child safety seat.

Adjust the rear seat headrest to the lowest position.



Warning:

After installation, push the child seat to different directions to confirm that it is firmly secured. The anchorage can only stand the load produced by the correctly installed child seat and cannot be used to secure other objects.

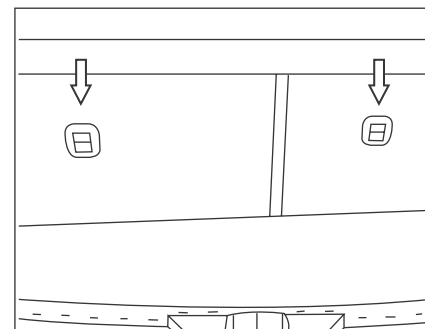

On H30 and H30 CROSS models, the child seat anchorage supports are located at the back of the rear seat backrest; four lower anchorage supports are provided for child seat under the ISO FIX mark on the rear seat backrest.

Unlock the rear seat backrest, turn over the backrest appropriately and adjust the headrest height; have the top strap of the child safety seat threaded through the middle part between two support legs of the headrest and hook it firmly to the anchorage supports; afterwards, push the rear seat backrest back to the original position and confirm that it is locked securely. Tension the top strap and secure the child safety seat.

Adjust the rear seat headrest to the lowest position.

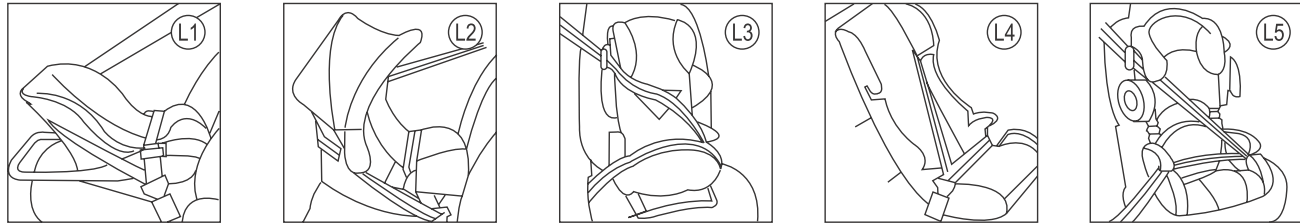

We recommend to apply the child safety seat suitable for securing by safety belt, so as to ensure the child's safety to the largest extent.

Always strictly observe the installation requirements specified in the operation instructions prepared by the child seat manufacturer.

Newborn to child of one year old

L1 type seat: Install it with the back towards the driving direction via a threepoint belt.

Child of 1-3 years old

L2 type seat: Secure it with the 2/3-point belt.

Child of 3-10 years old

L3 type seat: Secure it with the threepoint belt. The backrest height and width as well as the cushion length should be adjusted according to the age and body shape of the child.

L4 type seat: Secure it with the threepoint belt. Only the height should be adjusted for child up to or older than 6 years old (about 22 kg).

Child of 1-10 years old

L5 type seat: Secure it on the rear seat with the three-point belt. The backrest height and width as well as the cushion length should be adjusted according to the age and shape of the child.

To ensure the safety of infants (9-18kg), we recommend you to apply the protective guard.



Warning:

The child is vulnerable to serious injury during traffic accident due to no restraint or improper restraint. Therefore, it is required to install and use the child seat according to the relevant requirements specified in the operation instructions of the manufacturer.

CHILD SAFETY

1

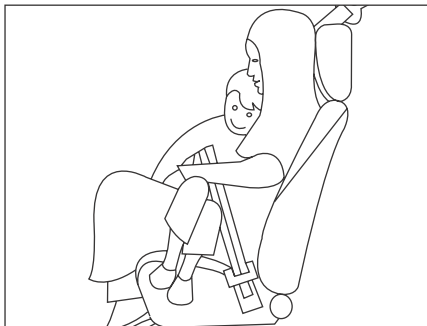

Warning:

Do not let several persons share the same safety belt. The impact of the adult during accident may be transferred to the child, thus causing serious injury.

Do not make the child sit on the adult's knees.



Warning:

Never hold the infant in your arm during driving. The weight of the infant before vehicle collision is light, however its inertia mass may increase substantially so that you cannot hold it firmly any more. For instance, a 5.5kg infant may turn to be 110kg and exert gravity on your arms during a vehicle collision at a speed 40km/h. The infant is hard to be held firmly at this moment. Always keep the infant in the child restraints.

Maintenance of safety belt

If the safety belt has suffered excessively large impact load, replace the safety belt and check the anchorage.

During braking, the safety belt may suffer sudden tension, and the retractor locking mechanism should have the safety belt locked at this moment.

If the retractor or safety belt cannot be locked in the above-mentioned cases, replace the safety belt assembly mandatorily.

When the safety belt is required to be cleaned, pull it out fully and wash it with the warm water containing a few of soap, and then have it retracted into the retractor after being dried completely. It is not allowed to carry moisture into the retractor.

Inspection of safety belt

Always ensure that the safety belt, buckle, latch plate, retractor and anchorage work normally. Check the safety belt system parts for any other looseness or damage. If any problem likely to interfere with the operation of safety belt is detected, have the belt serviced either at Dongfeng Franchise Store or IKCO authorised representatives.

If torn or worn out, the safety belt is unable to protect your safety any more during the vehicle collision. The impact generated during the collision may totally break the safety belt. Therefore, please replace the torn or worn safety belt immediately.

**Warning:**

- During the violent collision, the safety belt, if damaged, even slightly, should be replaced as a whole;
- Pay attention to protecting the safety belt against contamination from the glazing agent, engine oil, chemicals, especially electrolyte. It is much safer to clean the safety belt with the neutral soapy water.
- If the safety belt webbing is worn out on edges, contaminated or damaged, replace the whole safety belt.
- Any servicing and maintenance of the safety belt shall be done either by Dongfeng Franchise Store or IKCO authorised representatives .

DOOR WINDOW REGULATION

1

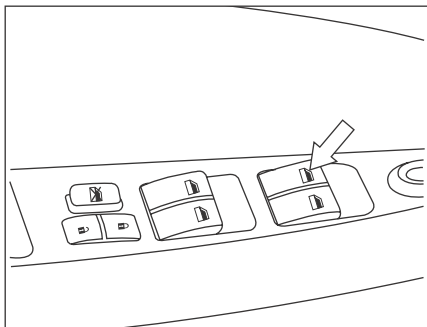

Electric regulation of front door window

Use the switch on the door at the driver's side to control the lifting/lowering of the two front door windows. The switch on the right front door is applicable to the right front door window only.

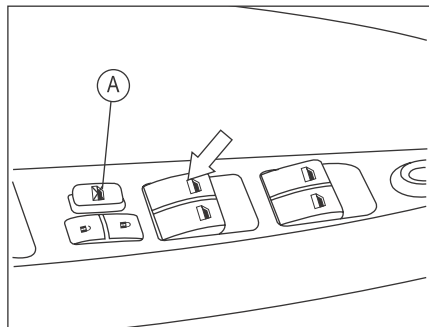

Electric regulation of rear door window

The driver can use the switch on the door at the driver's side to control the lifting/lowering of two rear door windows. The passenger at the rear seat can control the corresponding window via the switch on the rear door armrest.



Danger :

Confirm that the passenger's body parts including arm do not extend out of the vehicle when closing the window.

Do not leave the child or to-be-attended adult as well as pegs in the vehicle alone with no any other people around, because they may touch switches unconsciously and cause accident as a result, or even be suffocated due to high temperature and oxygen shortage.

Electric regulator switch

Press the door window regulator switch forward, and then the corresponding window will lower down. Release the switch to stop.

Flip back the door window regulator switch, and then the corresponding window will rise. Release the switch to stop.

Press down and hold the regulator switch, and then the corresponding door window will lower/rise to the bottom limit top limit.

One-touch lowering function for window at the driver's side:

Press down the switch heavily: the window will lower to the bottom automatically by once; Press down the switch slightly: release the hand to stop the lowering.

Power window locking switch

Switch (A) : high position: unlocking; low position: locking.

After pressing down the switch (A), only the window at the driver's side will be lifted lowered. Press down the switch again for unlocking.

The window regulator switch identification is provided with lighting function. The power supply to the window regulator switch will be kept for another 1 min after the ignition switch is disconnected (at St position).

INTERIOR EQUIPMENTS AND DASHBOARD

1

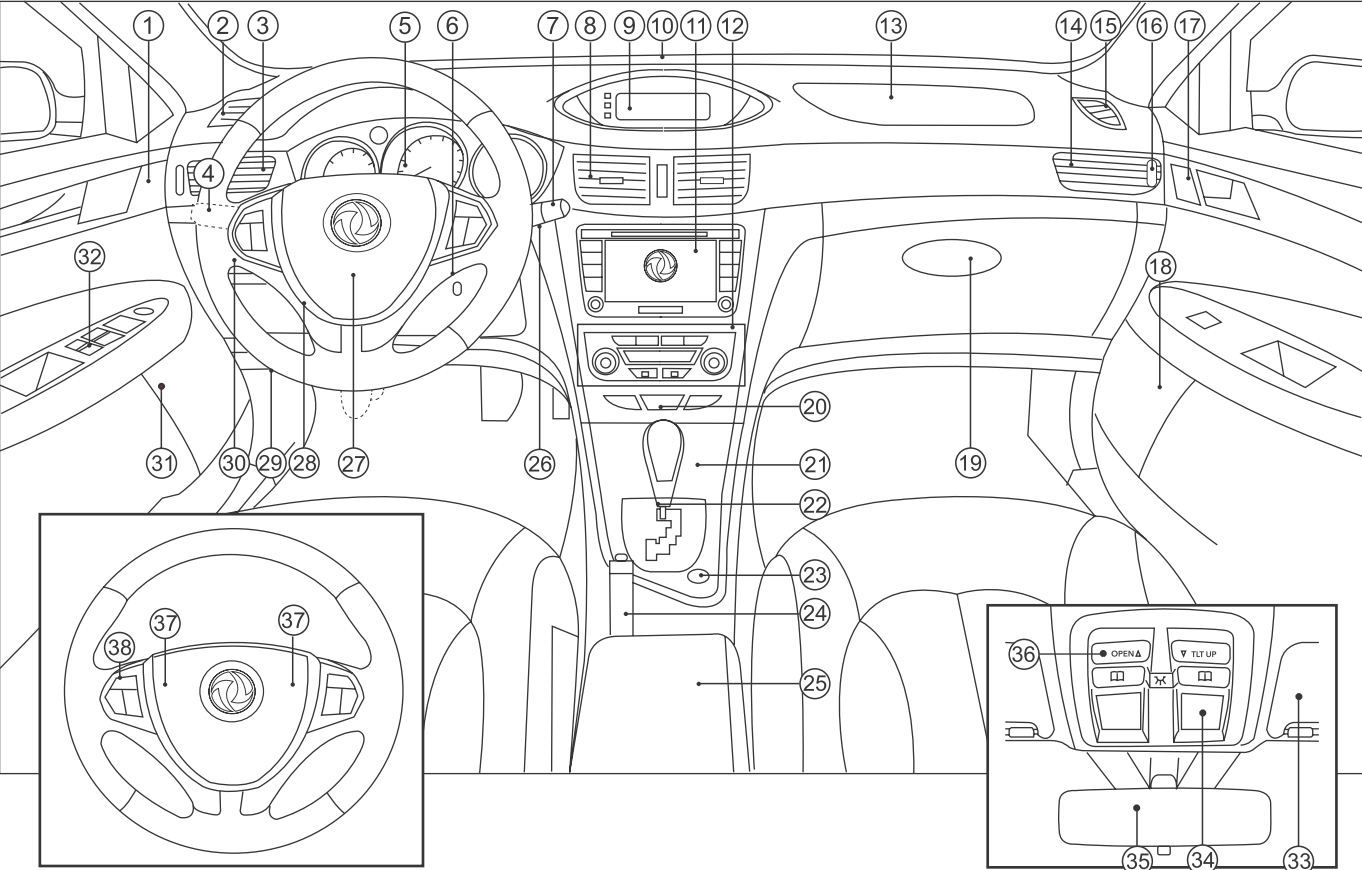

DASHBOARD

1

- 1) Left treble loudspeaker
- 2) Left door window defrosting vent
- 3) Left vent
- 4) Light combination switch
 - Turn signal lamp
 - Position lamp
 - Low beam/high beam
 - Front/rear fog lamp
- 5) Combination instrument
 - Indicator lamp/warning lamp
 - Tachometer
 - Speedometer
 - Water thermometer
 - Fuel gauge
 - Indicator for odometer, trip meter and instrument luminance adjustment
- 6) Ignition switch
- 7) Wiper combination switch
 - Front windshield wiper switch
 - Front windshield washer switch
 - Rear windshield wiper switch *
 - Rear windshield washer switch *
- 8) Middle vent
- 9) Multi-function display
- 10) Solar sensor*
- 11) Vehicle audio*
- 12) Air conditioning/ventilation control button*
- 13) Front airbag of front passenger
- 14) Right vent
- 15) Right door window defrosting vent
- 16) Vent switch
- 17) Right treble loudspeaker
- 18) Right front loudspeaker
- 19) Glove box
- 20) Hazard warning switch/cipher immobilizer indicator lamp
- 21) Storage box
- 22) Gear shift lever*
- 23) Cigar lighter
- 24) Parking brake lever
- 25) Central storage box
- 26) Inside temperature sensor air inlet*
- 27) Driver's front airbag
- 28) Steering wheel height adjusting handle
- 29) Engine hood opening handle
- 30) Card box
- 31) Left front loudspeaker
- 32) Left armrest control switch
 - Electric interior rearview mirror adjustment
 - Window regulator switch
 - Window regulator locking switch
- Central locking switch
- 33) Sun visor
- 34) Interior lighting lamp
- 35) Interior rearview mirror
- 36) Sunroof switch*
- 37) Horn switch
- 38) Audio control button*

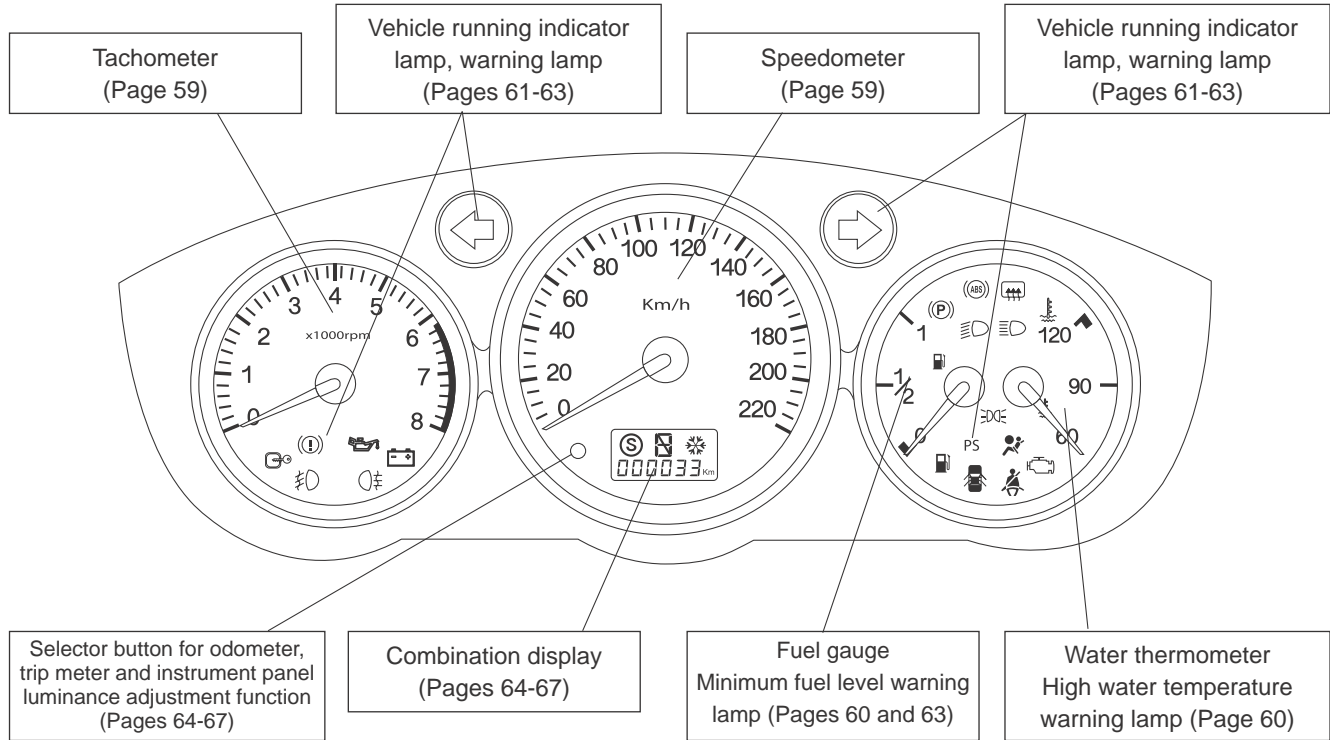

INDICATING INSTRUMENT

1

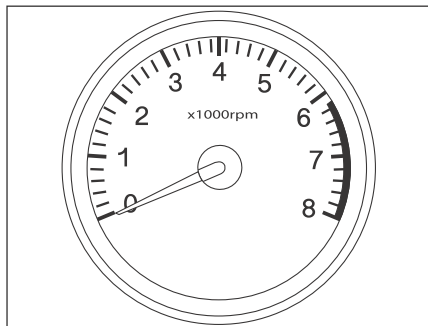

Tachometer

When the engine is started in cold state or the cooling device is turned on, the engine idle speed will surpass 1,000r/ min; after the engine working temperature increases and the cooling device is turned off, the engine idle speed will be:

N6A 10FX3A PSA engine: 820 ± 50 r/min

DFM A16 engine: 750 ± 50 r/min.

The upshifting should be done for manual transmission when the engine speed is more than 3,000r/min.

During the running-in period, it is better that the engine speed is no more than 4,000r/min.

The maximum engine speed should not go within the red area.

During the vehicle driving, it is inappropriate to have the engine run at a speed lower than 2,000r/min for a long time. The economic engine speed is about 2,500r/min.

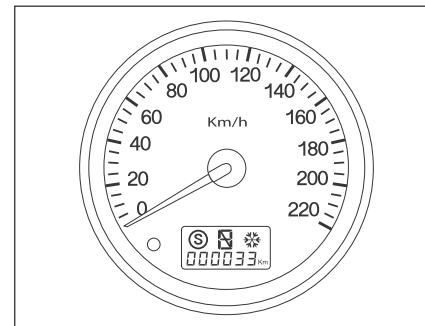

Speedometer

It is recommended to follow the driving speed allowed by the traffic regulations. The vehicle speed shall not be more than 40km/h during cornering.

If the vehicle is travelling under traction or in the spare mode of the automatic transmission, the speed shall not be more than 50km/h.

It is essential to ensure a favorable visibility and a safe braking distance when driving at high speed.

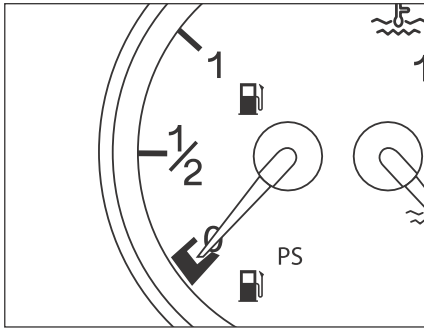

Fuel gauge

The vehicle running at a too low fuel level should be avoided; when the fuel is exhausted, the engine will supply oil irregularly or even stop, thus damaging the fuel pump and the three-way catalytic converter.

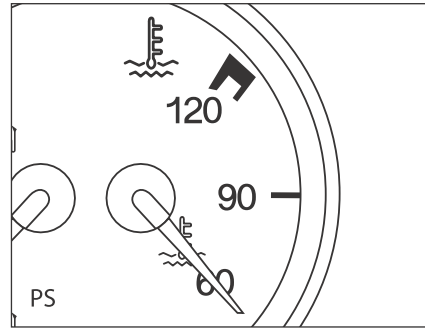

Water thermometer

High water temperature warning lamp
After the ignition switch is turned on, the pointer will indicate the engine coolant temperature.

Under the adverse application conditions, the pointer will approach the red warning area as the coolant temperature increases.

If the pointer directs to the red area, the water temperature is too high and the warning lamp will be lighted. In this case, make the engine return to the idle status and shut it down after running for several minutes, then park the vehicle.

Overheating may result from various reasons. Please contact either nearest Dongfeng Franchise Store or IKCO authorised representatives.

The cooling fan may keep working for a while after the hot engine is stopped.

INDICATOR LAMP AND WARNING LAMP

1

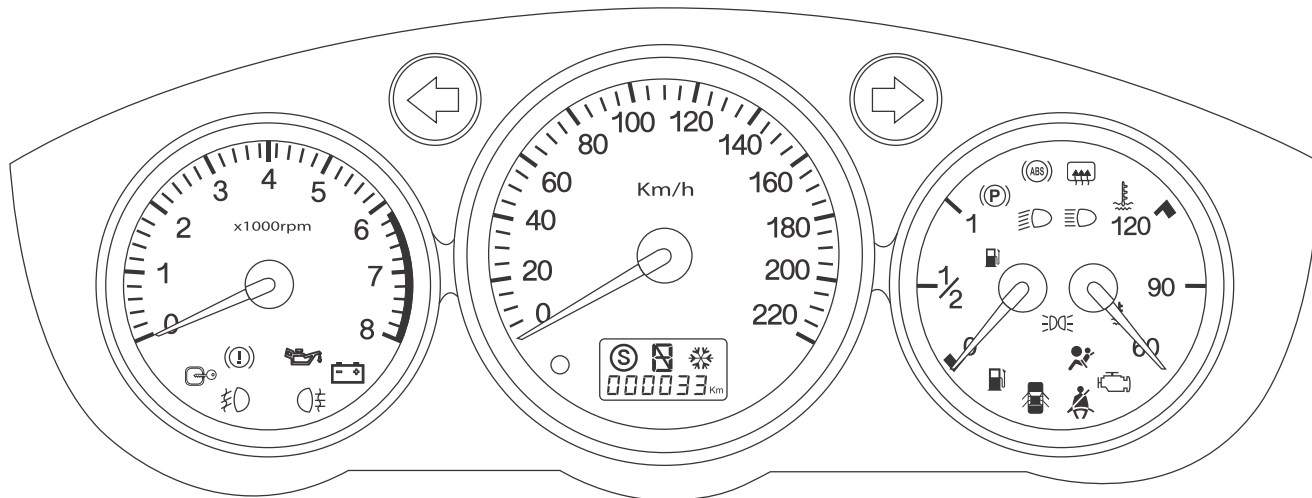

 **Left turn signal indicator lamp**
See Page 78 for details

 **Right turn signal indicator lamp**
See Page 78 for details

By operating the turn signal lamp switch, the outside turn signal lamp will glisten and the corresponding indicator on the instrument panel will flash. If either front or rear turn signal lamp is off, the flashing frequency of the indicator lamp will double. Press down the hazard warning switch, and the left/right turn signal indicator lamps will flash simultaneously.



Position lamp indicator
See Page 79 for details



Low beam indicator
See Page 79 for details



High beam indicator
See Page 79 for details



Front fog lamp indicator
See Page 79 for details



Rear fog lamp indicator
See Page 79 for details



Electric defogging indicator
See Page 107 for details



Parking brake warning lamp
If the parking brake lever is not released or is just released partially, the warning lamp will be lighted.



Low brake fluid level warning lamp
The lamp will be lighted in case of insufficient brake fluid. In this case, park the vehicle immediately and contact either nearest Dongfeng Franchise Store or IKCO authorised representatives for servicing.



Engine oil pressure warning lamp
If the lamp is lighted during the driving, shut down the engine, check the oil level and turn to either nearest Dongfeng Franchise Store or IKCO authorised representatives for help.



Battery charging warning lamp
The lamp should be off when the engine is running. If the lamp stays on or flashes, the charging fault or overlow voltage may occur. Please contact either nearest Dongfeng Franchise

Store or IKCO authorised representatives for servicing.



Door ajar warning lamp
If this lamp is on, it suggests that at least one door remains open. In case that the door is just slightly closed, the warning lamp may be off; therefore, please lock door. This lamp can keep on working when the ignition switch is disconnected.



Driver's safety belt unfastening warning lamp
The lamp is lighted with ignition key at M position. When the vehicle speed is higher than 10km/h and the safety belt is not fastened, the lamp will be lighted along with the audible alarm and will remain on after the audible alarm sounds for 30s. This lamp will be off when the driver tightens the safety belt buckle.



Airbag warning lamp
See Page 80 for details

INDICATOR LAMP AND WARNING LAMP

1



Cipher anti-start indicator lamp

The lamp will be on when the ignition switch is connected and off when the engine control system is recognized and connected.



Note:

If the indicator lamp flashes continuously, it suggests that the wrong key is used or the cipher anti-start system is failed; thus the vehicle cannot be started in this case.



High water temperature warning lamp

If the lamp is on, check the coolant level (see Pages 121-125).

Engine overheating may be caused by various reasons, and please contact either Dongfeng Franchise Store or IKCO authorised representatives immediately in this case.



Minimum fuel level warning lamp

When the minimum fuel warning lamp is lighted, it suggests that about 6L fuel remains in the fuel tank for usage. Please refill the fuel tank as soon as

possible.



ABS indicator lamp

After the ignition switch is turned on, the ABS indicator lamp will be lighted and then go out several seconds later.

The ABS is faulty if the lamp fails to be off.

In this case, the ABS function is failed but the vehicle can still be braked.



Engine malfunction warning lamp

(automatic inspection system)

The warning lamp will be on when the ignition switch is turned on and then off when the engine is started. During the travelling, if the warning lamp flashes or comes on, it suggests that the engine fuel injection system or the ignition switch is faulty; in this case, please contact either Dongfeng Franchise Store or IKCO authorised representatives as soon as possible.

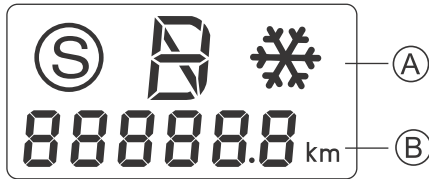

Functions of combination display

The combination display is divided into two functional zones:

Zone (A): displaying the gears of automatic transmission or automatic & manual transmission (not for manual transmission).

Zone (B): displaying the total mileage and subtotal mileage.

The total mileage is displayed as integral only.



Ignition switch turned off

All records and indicating icons are off.



Ignition switch turned on

The combination display recovers to the display before the ignition switch is turned off.

Switchover between odometer and trip meter

Press down the function selector button quickly to realize the switchover among odometer, trip meter and instrument panel luminance adjustment.



Trip meter zeroing

Press down the function selector button quickly to select the subtotal mileage to be zeroed; afterwards, press and hold the function selector button (more than 3s) to zero the selected subtotal mileage.



Note:

The total mileage is displayed on the combination display when the ignition key is turned off but the position lamp is turned on.



Note:

The subtotal mileage is progressively accumulative with an upper limit of 999.9; if reached, it will be zeroed automatically and then the counting will be resumed.

COMBINATION DISPLAY

1

Instrument panel luminance adjustment

- Turn on the ignition switch (M position).
- Press down the function selector button quickly to select the function of odometer, trip meter and instrument panel luminance adjustment.
- After selection, press down the function selector button again within 3s to adjust the luminance, with the grade of luminance regulated by each pressing operation and the backlight luminance changing circularly.
- The odometer display will be resumed automatically 3 s after the luminance adjustment.

The adjustment of luminance from high intensity to low intensity is as shown below:



Min. luminance



Luminance of 0-25%



Luminance of 25-50%



Luminance of 50-75%

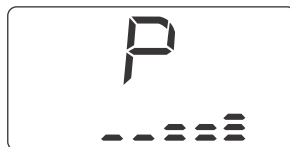

Luminance of 75-100%

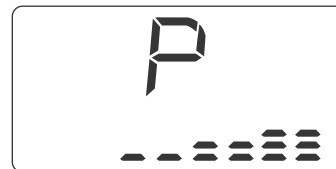

Max. luminance

Several minutes after the comfortable instrument panel backlight luminance is selected, the Zone B will display the total mileage.

The adjusted instrument panel backlight luminance is memorized and will be displayed each time after the ignition switch is turned on.



Warning:

It is strictly prohibited to adjust the instrument panel luminance during driving.

Automatic transmission gear display

The gears of automatic transmission will be displayed in the Zone A of the combination display: P, R, N, D, 2nd and L.

The operating mode of automatic transmission is displayed above the gear display:

Mode display:

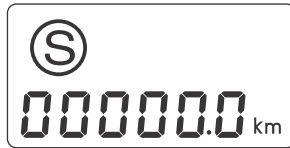

Sports



Snow

Gear display:



P



R



N



D



2nd



L



Note:

If the gear display indicator lamp on the combination display stably indicates a value or letter, the vehicle is at this gear or running at this gear. If the gear display on the combination display demonstrates symbol “_” with the “S” and “snowflake” indicator lamp flashing and the audible signal sounded, the automatic transmission may operate abnormally.

In this case, please contact either Dongfeng Franchise Store or IKCO authorised representatives.

COMBINATION DISPLAY

1

Integrated A/M transmission gear display

The gears of AT will be displayed in the Area A of the combination display: P, R, N, D and M.

The A/T operating mode is displayed above the gear display:

Mode display:

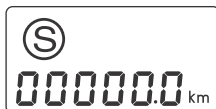

Sports



Snow

Gear display:



P



R



N



D

Display at M gear:

At M gear, the transmission is shifted to the manual mode with the gears able to be switched from 1st to 4th gears, as shown below.

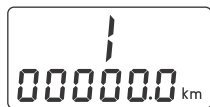

1st



2nd



3rd

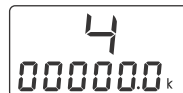

4th



Note:

If the gear display indicator lamp on the combination display stably indicates a value or letter, the vehicle is at this gear or running at this gear. If the gear display on the combination display demonstrates symbol “-” with the “S” and “❄️” indicator lamp flashing and the audible signal sounded, the automatic transmission may operate abnormally. In this case, please contact the Dongfeng Franchise Store or IKCO authorized representatives.

General

The multi-function display is used to display clock and date; through the operation of function key D, the following information can be shown in the display area in sequence:

Instantaneous fuel consumption/average fuel consumption/average speed /mileage/driving range and others.

The backlight of the multi-function display is linked with the light combination switch. The information on the multi-function display can be adjusted only when the ignition switch is at M position.

Description on panel layout:

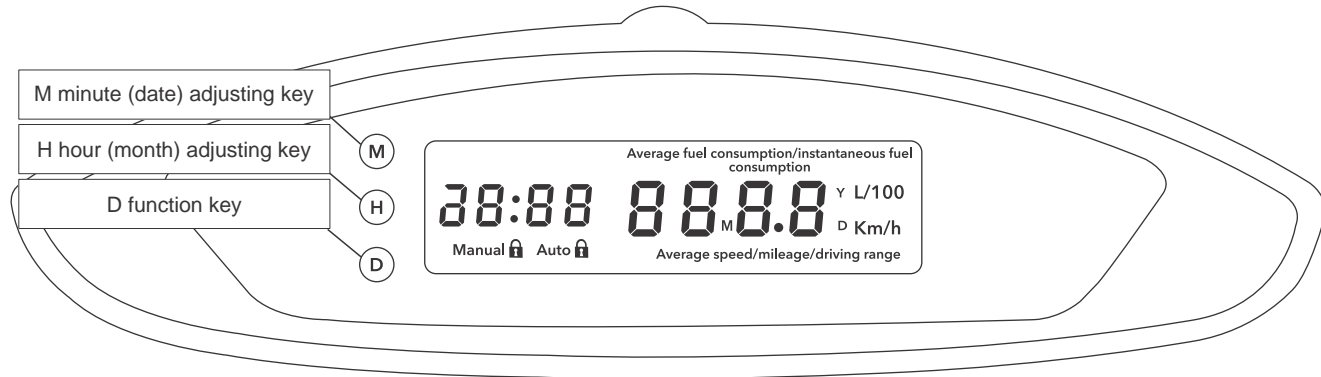

MULTI-FUNCTION DISPLAY (SEGMENT CODE)

1

Examples of display mode



Normal:

24h system, 18:00
Calendar (Feb. 9th)
Door self-locking deactivated



Instantaneous fuel consumption display:

24h system, 18:00
Instantaneous fuel consumption:
6.8L/100km
Door self-locking deactivated



Average fuel consumption display:

24h system, 18:00
Average fuel consumption: 6.0L/100km
Door self-locking deactivated



Average speed display:

24h system, 18:00
Average speed per hour: 60km/h
Door self-locking deactivated

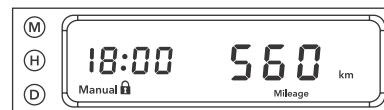

Mileage display:

24h system, 18:00
Mileage: 560km
Door self-locking deactivated

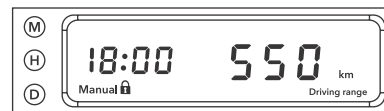

Driving range display:

24h system, 18:00
Driving range: 550.0km
Door self-locking deactivated



Note:

The instantaneous fuel consumption is not displayed when the vehicle speed is lower than 30km/h.

Function description**Clock**

- Displaying 24h system time with an initial display of 00:00 and the second digits flashing.
- Adjusting method: when the ignition switch is connected, press down the D key for more than 0.8s for clock adjustment (minute/second digits flash), press down the H key for hour adjustment (0-23 for 24h system) and the M key for minute adjustment (00-59). The normal display will be resumed 10s after the adjustment or by pressing down the D key.

Calendar

- The calendar is displayed as MM/DD.
- Calendar adjustment: When the ignition switch is connected, press down the D key for more than 0.8s for clock adjustment, afterwards, press down the D key for 0.8s to switch to the calendar adjustment mode (month/date digits flash).
Press down the H key for month adjustment (1-12) and the M key for date adjustment (1-31); afterwards, the normal display will be resumed 10s after the adjustment or by pressing down the D key.

Year

- Year mode: the year is displayed only in year setting mode (with the year digit flashing); the year determines the month and its change.
- Year adjustment: after the calendar adjustment, press down the D key for more than 0.8s for year setting (with the year digit flashing), and press the H key for increasing years and M key for decreasing years; the normal display will be resumed 10s after the adjustment or by pressing down the D key.

Travel information

The travel information is displayed in the calendar display area as per the following sequence:

- Calendar displayed in normal state: MM-DD
- Press the D key for 0.1s to switch to instantaneous fuel consumption display (see examples of display mode)
- Press down the D key again to switch to the average fuel consumption display (see examples of display mode)
- Press down the D key again to switch to the average speed display (see examples of display mode)

- Press down the D key again to switch to the mileage display (see examples of display mode)
- Press down the D key again to switch to the driving range display (see examples of display mode)

**Warning:**

- The clock and calendar should be adjusted when the vehicle is stopped.
- The travel information can be switched after ensuring driving safety.

MULTI-FUNCTION DISPLAY (DOT MATRIX)

1

General

The multi-function display is used to display clock, date and outside temperature; through the operation of D key, the following information can be displayed in the display area in turns:

Travel information such as normal mode and travel information 1 and travel information 2.

The multi-function display backlight is linked with the light combination switch.

The information on the multi-function display can be adjusted only when the ignition switch is at M position.

Description of panel layout:

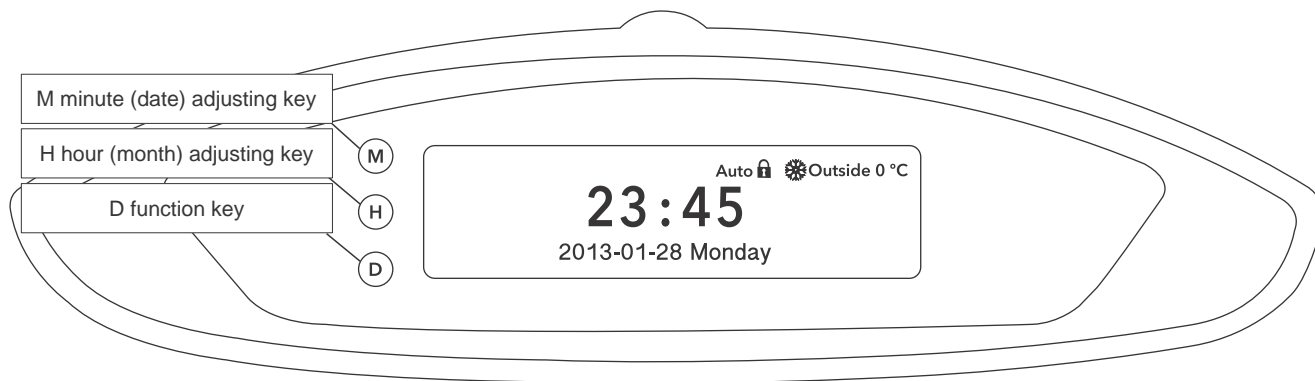

Examples of display mode



Power interface:

Displaying the DONGFENG AEOLUS brand for about 3s.

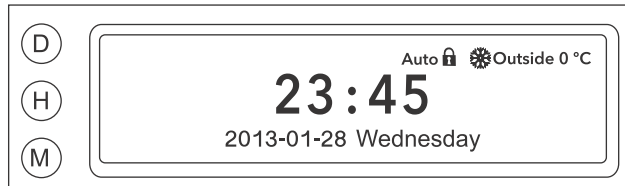

Normal mode:

24h system time, 11:45 pm
 Outside temperature: 4°C
 Calendar: 2013-02-27, Wednesday
 The door self-locking function works automatically

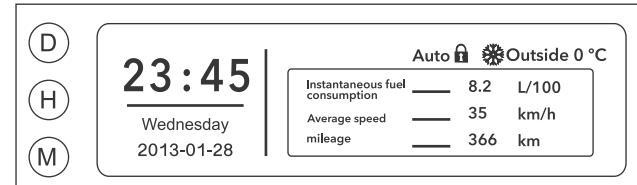

Travel information 1:

Displaying the normal mode information as well as:
 Instantaneous fuel consumption:
 8.2L/100km
 Average speed: 35km/h
 Mileage: 366km

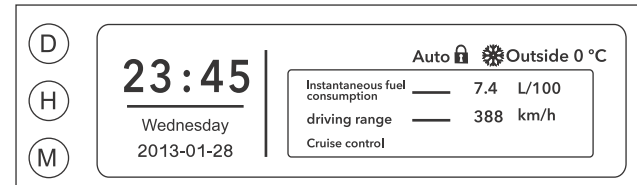

Travel information 2:

Displaying the normal mode information as well as:
 Average fuel consumption: 7.4L/100km
 Driving range: 388km
 The cruise control function is being activated

MULTI-FUNCTION DISPLAY (DOT MATRIX)

1

Examples of display mode

The multi-function display may, according to the activated vehicle functions, display the following function states.

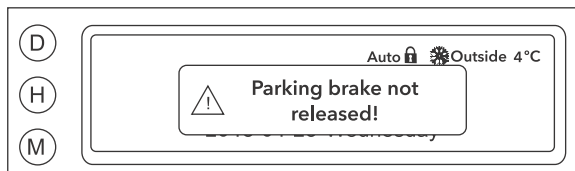

Interface indicating that parking brake is not released

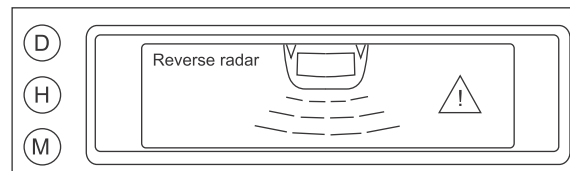

Interface displaying reverse radar distance

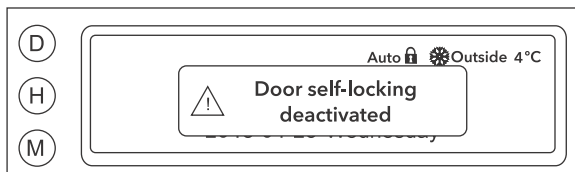

Interface indicating door self-locking is deactivated

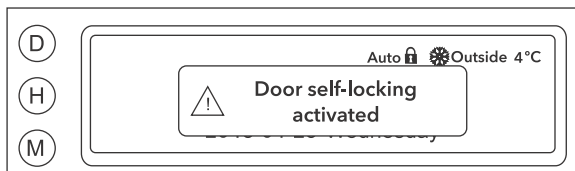

Interface indicating door self-locking is activated

Function description**Clock**

- Displaying 24h system time with an initial display of 00:00 and the second digits flashing.
- Adjusting method: when the ignition switch is connected, press down the key D for more than 0.8s for clock adjustment (minute/second digits flash), and press down the H key for hour adjustment (0 23 for 24h system) and the M key for minute adjustment (00- 59); the normal display will be resumed 10s after the adjustment or by pressing down the D key.

Calendar

- The calendar is displayed in the manner of YY/MM/DD, week.
- Calendar adjustment: after the ignition switch is connected, press down the D key for more than 0.8s for clock adjustment; after the adjustment, keep the state for 5s and switch to the calendar adjustment mode automatically.

Set the year at first (with the year digits flashing): press down the H key for increasing years and the M key for decreasing years.

Keep the state for 5s and automatically switch to the month setting mode (with the month digits flashing): press down the H key for increasing months and M key for decreasing months.

Keep the state for 5s and automatically switch to the date setting mode (with the date digits flashing): press down the H key for increasing days and M key for decreasing days.

Keep the state for 5s and automatically switch to the week setting mode (with the week digits flashing): press down the H key for increasing weekdays and M key for decreasing weekdays.

Automatically quit the clock and calendar adjustment mode by keeping this state for 5s later or pressing down the D key for more than 1s.

**Warning:**

- The clock and calendar should be adjusted when the vehicle is stopped.
- The travel information can be switched after ensuring driving safety.

Temperature

The outside temperature is displayed on the right top of the display as long as the power supply for the ignition switch is connected, with an accuracy of 1°C and measurement error of $\pm 1^\circ\text{C}$ (excluding sensors).

- The symbol  flashes at a frequency of 1Hz at $-3^\circ\text{C} \sim +1^\circ\text{C}$ (including the limits) and stays on below -3°C .
- The normal range for temperature displayed is $-40^\circ\text{C} \sim +80^\circ\text{C}$. If not, the temperature will not be displayed.
- The temperature display is out of the control of any key.

MULTI-FUNCTION DISPLAY (DOT MATRIX)

1

Travel information

Press down the D key to display the travel information 1; travel information 2 and normal mode in sequence. See examples of display mode for displaying status.

The maximum average fuel consumption displayed is 25.5L/100km; after an alarm is sent by the fuel gauge warning lamp on the combination instrument, only three short bars like “---” is displayed for Driving range.

After the system receives the cruise control signal, the letters reading “cruise control” will be displayed on the multifunction display; or else, nothing will be displayed.

The instantaneous fuel consumption will not be shown on the multi-function display when the vehicle speed is lower than 30km/h or when the vehicle is reversing.



Note:

Do not move the vehicle backwards any more when three levels of short bars indicating obstacles at the vehicle tail are lighted.

Reverse radar distance display

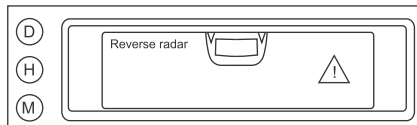

Only the vehicle tail is displayed when no obstacle is within the detecting range or the obstacle is more than 1.5m away from the vehicle tail.

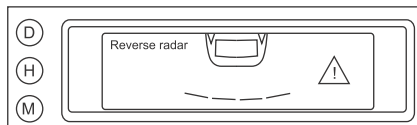

The vehicle tail is displayed and one level of short bar is lighted when the obstacle is detected to be 0.60-1.5m away from the vehicle tail.

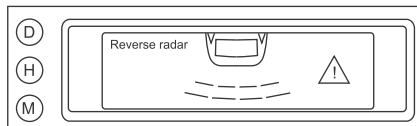

The vehicle tail is displayed and two levels of short bars are lighted when the obstacle is detected to be 0.3-0.6 m away from the vehicle tail.

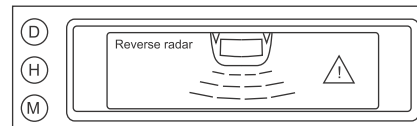

The vehicle tail is displayed, three levels of short bars are lighted and the buzzer sounds for a long period when the obstacle is detected to be shorter than 0.3m away from the vehicle tail.

If the radar system is in failure and three levels of short bars flash all the time, please contact the Dongfeng Franchise Store or IKCO authorized representatives in time for system overhaul.

Display of parking brake not released

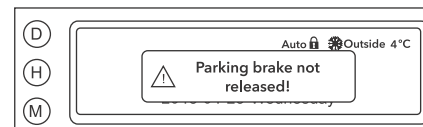

When the vehicle speed is higher than 5km/ h and the parking brake is not released or not released completely, warning words will pop out on the multi function display.

As long as the parking brake is released or the vehicle speed is lower than 5km/h, the warning words will disappear.

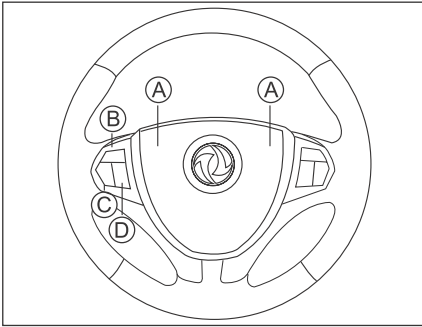

Ⓐ Horn

The horn will sound after the central pad on the steering wheel is pressed.

The horn should work normally regardless of the position of the ignition switch, unless the battery runs out. The horn can be used only in the following cases:

- There is danger nearby;
- Bicycle driver or pedestrian goes out of the designated road;
- The vehicle runs at the place with unclear road conditions.

Please sound the horn as per the local traffic rules.

Ⓑ, Ⓒ and Ⓓ are control keys integrated on the steering wheel.

Ⓑ mode switchover

Press the MODE key to realize switchover among four modes including AUX, SD, USB and radio; If there is not SD, AUX or USB, no response will be made by pressing down the MODE key.

Ⓒ Search

In radio mode:

Press down the “+” at the upper part of SEEK key to search radio station forwards;

Press down the “-” at the lower part of SEEK key to search radio station backwards.

After finding a station, stop searching and make the radio play at this frequency.

In SD and USB mode:

Press down the “+” at the upper part of SEEK key to play the next track;

Press down the “-” at the lower part of SEEK key to play the previous track.

Ⓓ Volume adjustment

Press the “+” at the upper part of the VOL key to increase the volume;

Press the “-” at the lower part of the VOL key to decrease the volume.

For operation instructions and precautions of sound system in detail, please see Chapter 7 Operation of Vehicle Sound System.

H30 CROSS ROOF RACK

1

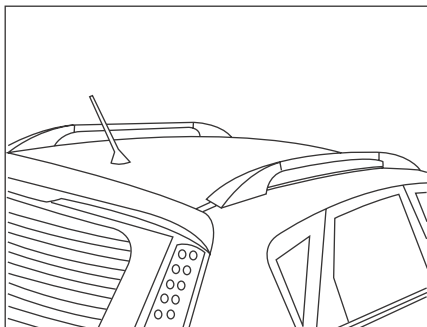

Roof rack

It is a must to install additionally transverse support fixing rod no matter what kinds of objects are transported on the roof (such as bicycle frame and ski carriers).

It is prohibited to hook or bundle the objects at any other places rather than the roof rack.

Suggestions

- When handling objects, neither damage the antenna, nor contact the roof to avoid scratching the vehicle paint;

- Distribute the load uniformly to avoid overload on one side;
- The part loaded with the heaviest object should be as close to the middle of the roof as possible;
- Bundle up the loads tightly with a rope; if the object is too large, make marks correspondingly;
- After loading the objects, the sensitivity to the influence of the side wind force will increase and the vehicle gravity center will rise. Please drive the vehicle prudently (as the vehicle stability may change);
- Once the transport is finished, disassemble the transverse support fixing rod mounted on the roof rack immediately.



Note:

The maximum load distributed on the roof rack should not be more than 20kg and the maximum loading height should not be more than 40cm (except for the bicycle frame). If this height is exceeded, control your driving speed according to the road condition, so as to avoid damaging the roof rack or possibly influencing the driving safety.

Please observe the relevant national transportation rules when transporting the over-long and over-wide objects.



Note:

The H30 CROSS is of crossover, with its shape in the SUV sporty style.

However, during the actual driving, please be careful and do not perform offroad driving to avoid vehicle damage.

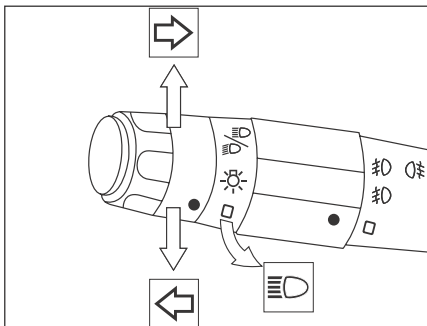

Headlamp alarm

The high beam will be lighted after the combination switch handle is lifted up once in the direction of the steering wheel plane and then off after the handle is released. It can be still effective after the ignition switch is disconnected.

Turn signal lamp switch

Press down the combination switch handle to turn left.

Lift up the combination switch handle to turn right.

During the steering, make the combination switch handle overpass the limit point in the designated direction, and the turn signal lamp switch will automatically reset along with the alignment of steering wheel.

Lane change indicator lamp

When you want to change the lane, slightly toggle the combination switch handle:

To change to the left lane, slightly press down the combination switch handle but do not pass the limit point, and the left turn signal indicator lamp will automatically go out after flashing for three times.

To change to the right lane, slightly lift up the combination switch handle but do not pass the limit, the right turn signal indicator lamp will automatically go out after flashing for three times.

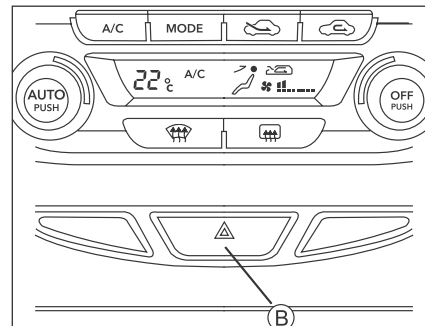

Hazard warning switch

Press down this switch, and the left/right turn signal indicator lamp and the turn signal lamp will flash simultaneously.

The warning switch can be used only in such dangerous conditions as emergency parking and driving in abnormal conditions.

The hazard warning switch can be still effective even though the ignition switch is disconnected.

If the hazard warning switch is connected, the operation to the turn signal lamp will be ineffective.

LIGHT COMBINATION SWITCH

1

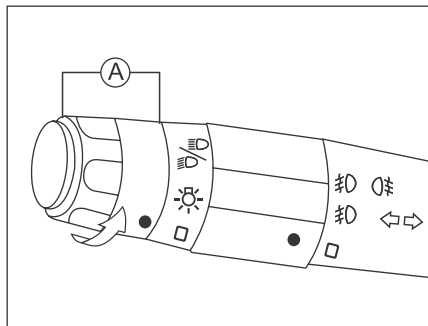

Lamp switch (ring A)



Making all lamps off



Rotate the ring A



Making the position lamp or instrument panel lighting on



Continuously rotate the ring A



Making the low beam/high beam on

Pull the light combination switch handle in the direction of driver to switch to the low beam or high beam.

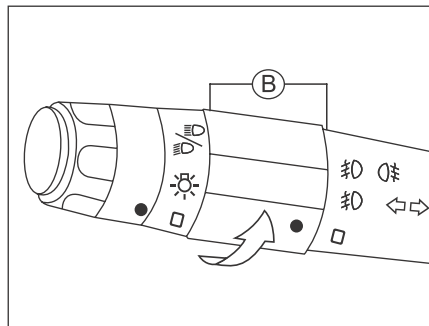

Fog lamp switch (ring B)*



Making front/rear fog lamp off



Rotate the ring B



Making the front fog lamp on

Only when the position lamp, high beam or low beam is lighted can the front fog lamp comes to work.



Continuously rotate the ring B

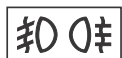

Making the front/rear fog lamps on

When turning off the position lamp, the ring B for front/rear fog lamp will rotate along with it, automatically disconnecting the rear fog lamp and returning to the front fog lamp position.

Note: The fog lamp is used in foggy, rainy or snowy days only.

Lamp non-turned off alarm

If the lamp is not turned off and the ignition switch is disconnected, the alarm will sound for 30s; when the lamp is turned off or the ignition switch is turned on, the alarm will stop working.

Delay lighting (“follow-me-home” function)

If the position switch is turned on once, shut down the engine, rotate the turn signal lamp switch to right turn and then reset it, and lock the door; afterwards, all turn signal lamps will be lighted for about 15 s to facilitate you leave the parking lot. The delay lighting will be turned off by pressing down the locking key on the remote controller or go out automatically at the end of the delay.

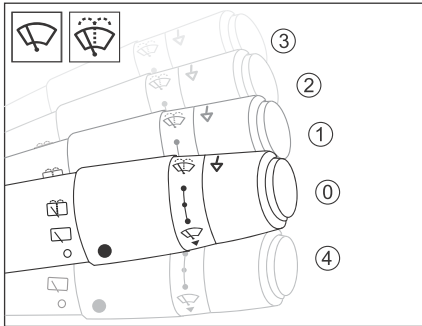

Front windshield wiper switch

- ① Stop
- ① Intermittent wiping
- ② Normal wiping
- ③ Quick wiping
- ④ Single-step wiping: pressing the combination switch handle once for one wiping operation only

Front windshield washer switch

Pull the combination switch handle in the direction of the steering wheel plane, and then the windshield washer will spray washer fluid and the wiper will come to work. After stopping spraying fluid, the wiper will keep on working for three cycles after delay.

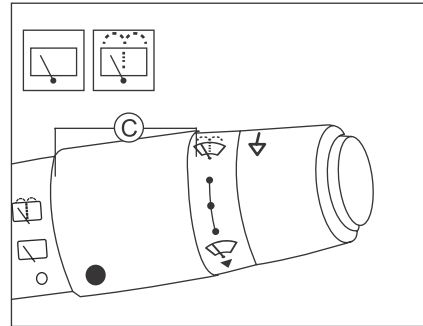

Rear windshield wiper switch



(H30, H30 CROSS)

Rotate the © ring on the handle forwards to the position , and then the rear windshield wiper will wipe intermittently.

The wiper will stop wiping after the handle is returned to position .

Rear windshield washer switch

(H30, H30 CROSS)

Rotate the © ring on the handle forwards continuously to the position , and then the washing and wiping will be performed at the same time; release the handle to stop the fluid spraying. Then, when the switch returns to position , automatically, the wiper continues wiping for three times and then automatically switches to the intermittent wiping mode.



Note:

In freezing days, check whether the wiper arm can move freely before using the wiper; if there is accumulated snow or ice, clean it at first and then turn on the wiper. If the wiper arm fails to move freely, turning on the wiper switch forcibly may damage the wiper rubber strip, motor and others.

In non-rainy days, the wiper should be used to spray glass washer fluid, so as to avoid glass scratch or earlier damage of wiper rubber strip in case of dry wiping. The glass washer fluid is also required to be sprayed when using wiper in light rain. It is prohibited to use the washer without washer fluid.

YOUR VEHICLE AT A GLANCE

1

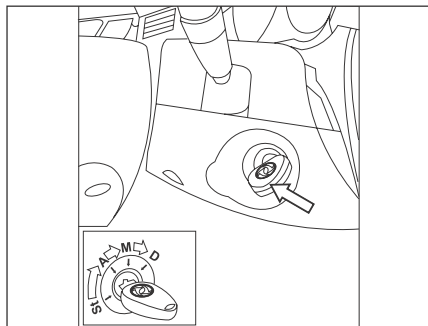

St: steering wheel locking position

Unlocking: Slightly rotate the steering wheel leftwards and rightwards when rotating the ignition key to unlock the steering wheel.

Locking: After the vehicle is completely stopped, apply the parking brake tightly, take off the ignition key and rotate the steering wheel slightly to ensure that the steering wheel is locked.

Turn off the ignition switch to position A or St and open any one of door without taking off the ignition key; afterwards, the buzzer will alarm for about 20s and then stop alarming after the ignition key is taken off or the door is closed.

A: Working position of electrical accessories

If the ignition key is at this position, the electrical accessories can be used and the battery charging indicator lamp will be lighted.

M: Ignition switch operating position

At this position, the combination instrument backlight will be lighted and the following indicator lamps or warning lamps should come on for a short while and then go out: cipher anti-start indicator lamp, ABS indicator lamp, airbag warning lamp and cruise control indicator lamp*.

If the cipher anti-start indicator lamp goes out, then the engine can be started.



The following warning lamps should stay on before the engine goes to run:

Engine oil pressure warning lamp, battery charging lamp, parking brake warning lamp, EPS warning lamp, engine malfunction warning lamp and

driver's safety belt unfastening warning lamp.



Note:

The **PS** warning lamp is only available on instrument of models equipped with DFM A16 engine.

D: START position

Release the key immediately after the engine is started; then the key will return to M position automatically.



Note:

Do not rotate the key to START position when the engine is running.

Ensure that the shift lever is switched to the N (MT) or P/N position (AMT).

Engine cold start

Before starting, do not depress the accelerator pedal back and forth in advance.

Rotate the ignition key to activate the starter until the engine is started; afterwards, release the ignition key immediately (Do not run the starter for more than 10s each time).

For vehicle equipped with manual transmission, if the temperature is lower than 0°C, depress the clutch pedal to reduce the engine running resistance and facilitate the engine start as a result. Release the clutch pedal slowly after the engine is started.



Danger:

Do not take off the ignition key if the vehicle is not completely stably parked, or else, there is a risk that the steering wheel will be locked or some safety functions will fail to work.

To ensure the normal functioning of brake booster and steering booster, it is prohibited to coast the vehicle with engine shut down.



Danger:

Do not run the engine for a long time in enclosed or badly-ventilated site to avoid exhaust gas poisoning.

REARVIEW MIRROR

1

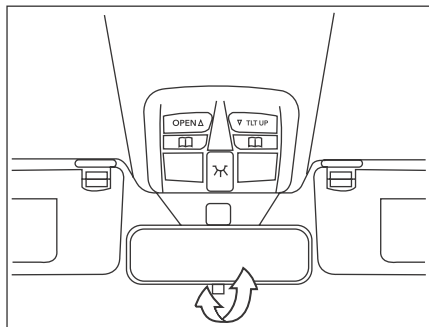

Interior rearview mirror

Grip and rotate the interior rearview mirror to adjust it to the appropriate position. The toggle at the lower edge enables the rearview mirror to be set at the following two positions:

- Daytime position (with toggle forward)
- Night position (with toggle backward)

The toggle at the lower edge of the rearview mirror should be pushed or pulled when shifting from one position to the other position.

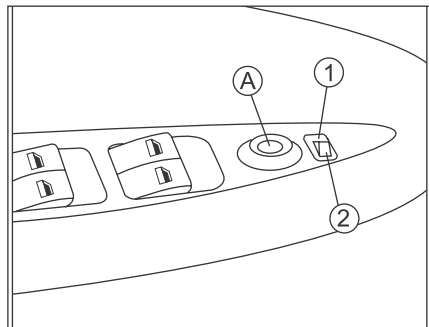

Electric exterior rearview mirror

Select the rearview mirror to be adjusted:

- ① Rearview mirror at driver's side (turning the knob leftward)
- ② Rearview mirror at passenger's side (turning the knob rightward)

Adjust the exterior rearview mirror in four directions by adjusting knob (A). Switch the selector key to the middle position after the adjustment.

Rearview mirror defrosting/defogging*: This function is linked with the rear window defrosting/defogging function.

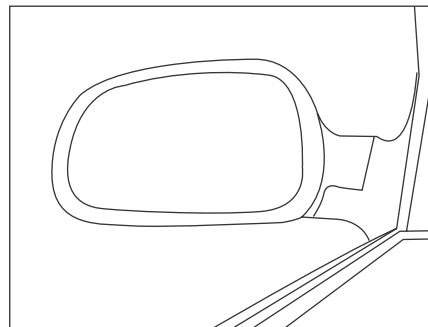

The rearview mirror plane is of sphere to enlarge the visual field on sides.

The distance of objects seen from the mirror is farther than the actual situation; thus, please estimate the distance correctly.



Danger:

Do not adjust the rearview mirror during driving to ensure driving safety.

After parking, fold the rearview mirror manually backwards if necessary; open it before driving.

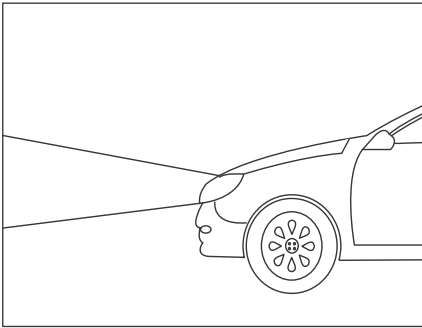

Headlamp adjustment

Adjust the beam angle of the vehicle headlamp according to the vehicle load, so as to obtain the optimal lighting effect.

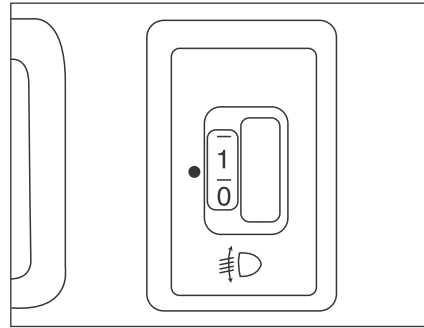

Headlamp beam height adjusting knob

When the ignition switch is at “ON” position and the headlamp is turned on, the headlamp beam control will come into effect, so as to adjust the headlamp optical axis according to the driving situation.

If there is no heavy load/luggage or the vehicle runs on the flat road, select the common position “0”.

If the number of passengers and the load/luggage changes inside, the headlamp optical axis will be higher than its normal position.

If the vehicle drives on the bumps, the headlamp may directly project to the rearview mirror or the exterior rearview mirror of the vehicle in front or to the windshield of the incoming vehicle, making other drivers fail to see clearly.

If it is necessary to adjust to the appropriate light velocity, rotate the corresponding switch. The larger the figure indicated on the switch, the lower the headlamp optical axis is.

Select the switch position with reference to the following examples:

Switch position	Load in trunk	Number of passengers
0	No load	Driver only
0	No load	Front seats: 2
1	No load	Front seats: 2 Rear seats: 3
2	Full load	Front seats: 2 Rear seats: 3
3	Full load	Driver only

2 DRIVING

TRANSMISSION (STARTING/DRIVING) *	90
ELECTRIC POWER STEERING*	96
BRAKE.....	97
REVERSE RADAR*	99
REVERSE IMAGE*	100

*If installed on your vehicle

TRANSMISSION (STARTING/DRIVING) *

2

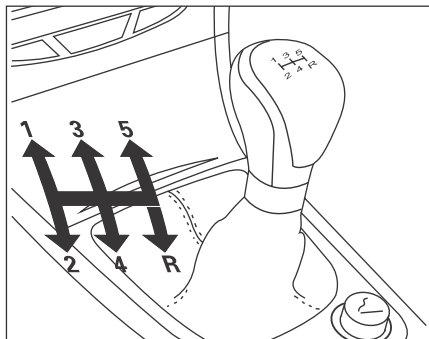

Manual transmission

Five direct gears and one reverse gear. During gear shifting, depress the clutch pedal to the limit; then release it slowly after shifting. **During driving, do not put the foot on the clutch pedal all the time; or else, it is easy to cause clutch failure.**

Start the vehicle at the 1st gear.

Do not apply the reverse gear before the vehicle is completely stably stopped.

Slowly shift the reverse gear to avoid noises and even transmission damage.

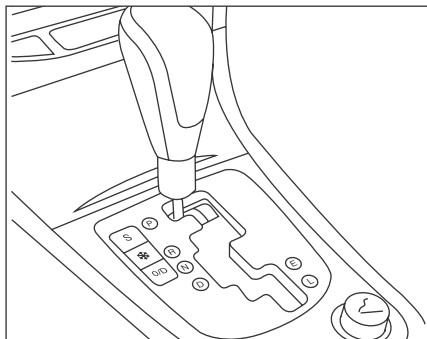

Automatic transmission

The engine can be started only when the shift lever is at parking gear (P) or neutral gear (N).

When the shift lever is at other gears, the internal safety locking mechanism will cut off the ignition circuit, therefore, the engine cannot be started.

After the engine is started, depress the brake pedal and shift to the automatic direct gear (D) or reverse gear (R) according to the actual requirements.

Then, the vehicle can be started for driving after releasing the brake pedal.



Note:

When the vehicle equipped with the reverse radar is shifted to the reverse gear, the radar alarm will beep once.



Note:

Protect the automatic transmission control panel guide groove from invasion of foreign matters such as coins and melon seeds as well as fluids such as water and juices, to avoid transmission manipulation malfunction.



Note:

The automatic transmission is provided with shift lever P-gear locking function; therefore, the shift lever will be locked once being switched to the P gear. Do not pull the shift lever forcibly in the case.

Instead, depress the brake level to unlock the P gear when the ignition key is connected to realize gear shift.

- The parking gear (P) can be shifted only when the vehicle is completely stably stopped after depressing the brake pedal.
- Always confirm that the shift lever is at parking gear (P) before leaving the vehicle.

Gear display for automatic transmission

The upper area of the combination display on the instrument panel is for gears display of automatic transmission. The gears of the automatic transmission are indicated by the gear display.

Driving mode

Normal mode: Such mode is applicable for all normal driving conditions. In the mode, if the vehicle is running with favorable economy, all indicator lamps on the key will go out.

S Sports mode: It is applicable to sporty driving of race. During automatic shifting, the engine speed is relatively high, so as to ensure the driving power performance and acceleration performance in priority. Once the sports mode is selected, the indicator lamp “S” on the key will be lighted.

❄️ Snow mode: The relatively gentle driving mode is applicable for driving on the wet and slippery road since the engine speed during automatic shifting is relatively low. After selecting the snow mode, the indicator lamp “❄️” on the key will be lighted.

O/D O/D mode: when the shift lever is shifted to D gear, the automatic transmission will be shifted to 3rd gear to the largest extent as this button is pressed down; if this mode is activated when the transmission is shifted to 4th gear, then the transmission will be shifted to 3rd gear in a constrained manner. The indicator lamp on this button will come on when the O/D mode is selected. The O/D mode should be selected when driving down the slope in hill area to improve the engine braking effect. The O/D mode can also prevent the frequent gearshift between 3rd and 4th gear when driving in urban area and no high speed or intermittent driving is required.

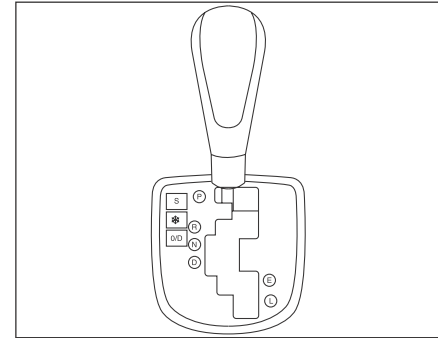

Selection of driving mode

- Press down the S key, the indicator lamp S will be lighted and the vehicle enters the sports mode; press down the S key again to return to the normal mode.
- Press down the “❄️” key, the indicator lamp “❄️” will be lighted and the vehicle enters the snow mode (when the 1st gear fails to function). Start the vehicle at 2nd gear. Press down the “❄️” key again to return to the normal mode.
- When the O/D button is pressed down, the O/D indicator lamp will come on, and the vehicle gets into the O/D mode; pressing the O/D button again can make the vehicle return the normal mode.

*If installed on your vehicle

TRANSMISSION (STARTING/DRIVING) *

2

Gear selection of automatic transmission

P: Parking gear

During parking, park the vehicle completely stably at first and then switch the shift lever to this gear.

Switch the shift lever to P gear and then pull up the parking brake lever to prevent the vehicle from sliding during parking.

R: Reverse gear

During reversing, park the vehicle completely stably at first and then switch the shift lever to the reverse gear.

N: Neutral gear

The neutral switch can be selected when the driver tends to park the vehicle briefly without leaving the vehicle.

D: Automatic direct gear

D gear is for normal use and can be applied for vehicle start at any time. The automatic transmission can automatically realize shifting within 1st-2nd-3rd-4th gears according to the vehicle driving condition.

2: 2nd gear

The automatic gearshift between 1st gear and 2nd gear of the transmission is available. Please shift it to 2nd gear when driving on a long slope or under poor road condition.

L: 1st gear (fixed-gear)

Please select L gear when driving on a slope at a low speed.



Note:

It is prohibited to make the vehicle slide at neutral gear during driving.



Note:

When the vehicle equipped with the reverse radar is shifted to the reverse gear, the radar alarm will beep once.



Note:

It is prohibited to perform manual downshifting forcibly when the engine speed is higher than 4,000 r/min.

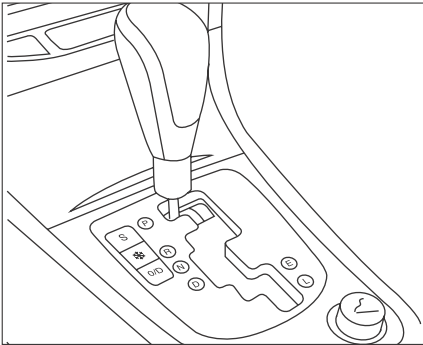

Automatic & manual transmission

The engine can be started only when the shift lever is at parking gear (P) or neutral gear (N).

When the shift lever is at other gears, the internal safety locking mechanism will cut off the ignition circuit; therefore, the engine cannot be started.

After the engine is started, depress the brake pedal and shift to the automatic direct gear (D) or reverse gear (R) according to the actual requirements.

Then, the vehicle can be started for driving after the brake pedal is released.

When the vehicle is travelling at D gear, the M gear can be switched to at any time, and the transmission can be switched to manual mode. According to the road condition, push the shift lever in direction of “+” for upshift and in direction of “-” for downshift. The gear is indicated on the combination display (see Page 66).

After upshift or downshift, the shift lever will return to the M gear automatically and can be switched between M gear and D gear freely.



Note:

When the vehicle equipped with the reverse radar is shifted to the reverse gear, the radar alarm will beep once.



Note:

Protect the automatic & manual transmission control panel guide groove from invasion of foreign matters such as coins and melon seeds as well as fluids such as water and juices, to avoid transmission manipulation malfunction.



Note:

The automatic & manual transmission is not provided with shift level P-gear locking function; therefore, the shift level will be locked once being switched to the P gear. Do not pull the shift lever forcibly in this case.

Instead, depress the brake pedal to unlock the P gear when the ignition key is connected to realize gear shift.

- The parking gear (P) can be shifted only when the vehicle is completely stably stopped after depressing the brake pedal.
- Always confirm that the shift lever is at parking gear (P) before leaving the vehicle.

Gear display for automatic & manual transmission

The upper area of the combination display on the instrument panel is for gears display of the automatic & manual transmission.

The gears of the automatic & manual transmission are indicated by the gear display.

Driving mode

Normal mode: Such mode is applicable for all normal driving conditions. In this mode, if the vehicle is running with favorable economy, all indicator lamps on the key will go out.

S Sports mode: It is applicable to sporty driving of race. During automatic shifting, the engine speed is relatively high, so as to ensure the driving power performance and acceleration performance in priority.

Once the sports mode is selected, the indicator lamp "S" on the key will be lighted.



Snow mode: The relatively gentle

driving mode is applicable for driving on the wet and slippery road since the engine speed during automatic shifting is relatively low. After selecting the snow mode, the indicator lamp "❄" on the key will be lighted.



Manual mode: The application of manual mode can enhance the driving pleasure. To protect the transmission, only when the vehicle and engine speeds are appropriate can the transmission realize upshift or downshift after shifting.

It is useless to move the shift lever continuously and the gear can only be switched in sequence from 1st to 4th gears.

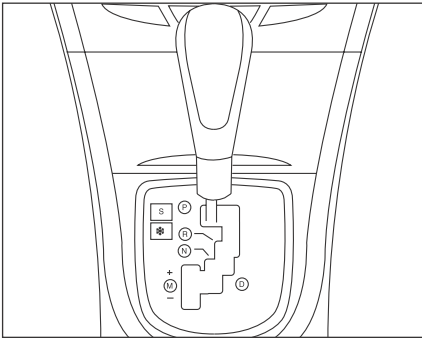

Selection of driving mode

- Press down the S key, the indicator lamp S will be lighted and the vehicle will enter the sports mode; press down the S key again to return to the normal mode.
- Press down the “❄️” key, the indicator lamp “❄️” will be lighted and the vehicle will enter the snow mode (when the 1st gear fails to function). Start the vehicle at 2nd gear. Press down the “❄️” key again to return to the normal mode.
- The switchover between M gear and D gear can be performed at any time.

Gear selection of automatic & manual transmission

P: Parking gear

During parking, park the vehicle completely stably at first and then switch the shift lever to this gear.

Switch the shift lever to P gear and then apply the parking brake to prevent the vehicle from sliding during parking.

R: Reverse gear

During reversing, park the vehicle completely stably at first and then switch the shift lever to the reverse gear.

N: Neutral gear

The neutral switch can be selected when the driver tends to park the vehicle briefly without leaving the vehicle.



Note:

When the vehicle equipped with the reverse radar is shifted to the reverse gear, the radar alarm will beep once.

D: Automatic direct gear

D gear is for normal use and can be applied for vehicle start at any time. The automatic transmission can automatically realize shifting within 1st 2nd-3rd-4th gears according to the vehicle driving condition.

M: Manual gear

This gear can be used for manual gearshift.

Push towards “+” for upshift,
Pull towards “-” for downshift,

The gear can be shifted only when the vehicle and engine speeds are appropriate.



Note:

It is prohibited to coast the vehicle at neutral gear during driving.



Note:

It is prohibited to perform manual downshift forcibly when the engine speed is higher than 4,000 r/min.

ELECTRIC POWER STEERING*

2

The electric power steering system is able to provide assistance during driving, so as to reduce the operation efforts of steering wheel.

During parking or driving at excessively low speed, if the steering wheel is operated repeatedly or continuously, the assistance to the steering wheel will decrease, so as to protect the electric power steering system against overheat and damage. When the assistance reduces, the operation to the steering wheel becomes harder. It, however, will recover to be normal after the temperature of the electric power steering system lowers down. Please avoid such a kind of steering wheel operation, since it will cause the electric power steering system overheat.

When rotating the steering wheel quickly, grating may be heard and it is not a fault. When the engine is running, the EPS warning lamp will be lighted, suggesting that the electric power steering system has problems; the steering booster will fail to work but still can help to control the vehicle. However, a larger force

shall be used to operate the steering wheel, especially during sharp turning or low-speed driving.

In such a case if any, park the vehicle at a safe place and shut down the engine; restart the engine to reset the system. EPS warning lamp will be lighted, but the engine shall be shut down after traveling for a certain distance. If the lamp fails to go out or is re-lighted during the driving, have your vehicle inspected at either Dongfeng Franchise Store or IKCO authorised representatives.



Note:

- If the engine fails to run or stop during driving, the steering assistance will lose and the steering wheel operating effort will be larger.
- If the EPS warning lamp is lighted when the engine is running, the steering wheel assistance will lose but you can still control the vehicle. However, larger force is required to operate the steering wheel especially during sharp turning or low-speed driving.

The brake system has two independent hydraulic oil circuits. If one circuit fails, the other can brake the wheel as well.

Application of brake

Do not put the foot on the brake pedal during driving, or else, the brake will be overheated, the wear of brake disc and brake block will be speeded up and the fuel consumption will increase.



Warning

- Do not coast the vehicle with the engine shut down.
- To reduce brake wear and avoid brake overheat, decrease the speed and switch to the lower gear when driving down a long slope. Brake overheating will weaken the brake performance, causing the vehicle out of control. On the smooth road, be careful for braking, accelerating or downshift. Sudden braking or accelerating will cause wheel slip and then accident as a result.

Type of brake

This vehicle applies the vacuum booster brake, which utilizes the engine vacuum effectively to enhance the brake force.

If the engine stops, the vehicle can still be braked by depressing the service brake pedal. But a larger pressure is required to stop the vehicle and the brake distance will be lengthened.

If the engine fails to run or is shut down during driving, the brake booster will not work and a larger force is required to depress the brake pedal.

Precautions for brake wetting

When washing vehicle or driving in water, the brake may be wetted. As a result, the brake distance will be lengthened and the vehicle will drift during braking.

To dry the brake, slightly depress the service brake pedal when the vehicle travels at a safe speed, heating the brake until the brake recovers normal. Avoid high-speed driving before the brake can work normally.

Function of ABS

ABS is the abbreviation for anti-lock brake system. It is only required to depress and hold the service brake pedal to operate this system.

ABS controls the brakes of all wheels to prevent the wheel from locking during emergency braking and braking on the smooth road.

This system adjusts the brake fluid pressure by detecting the rotary speed of each wheel, so as to prevent the vehicle from side sliding due to wheel locking.

This system, through avoiding wheel locking, helps the driver to control the steering wheel better and reduces the possibility of side sliding when the vehicle brakes on the smooth road.

BRAKE

2

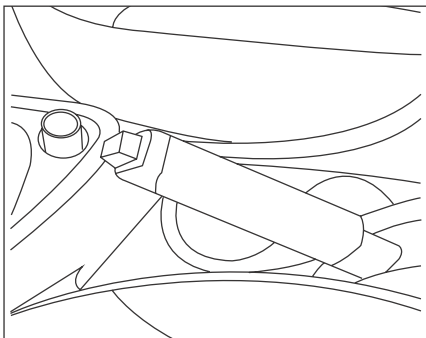

Parking brake (hand brake)

Pull the control lever backwards to enable the parking brake.

To release the parking brake, slightly pull the control lever upwards and press down the locking button at the end at first, and then release the lever forwards to the limit.

If the ignition switch is connected but the parking brake lever is not released or not released completely, the parking brake warning lamp will be lighted.



Note:

Release the parking brake lever when starting the vehicle for traveling.



Warning

- Do not drive the vehicle when the parking brake is applied, or else, the brake will fail to work due to overheating, thus causing accidents.
- Do not use the transmission instead of the parking brake. For parking of vehicle equipped with automatic & manual transmission, push the shift lever to P gear and apply the parking brake at the same time.
- Do not leave the child or to beattended adults in the vehicle alone, to avoid accident due to accidental release of parking brake by them.

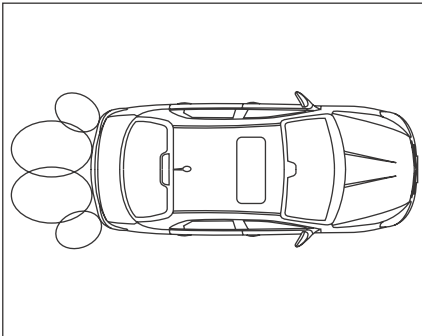

Reverse radar

The obstacle detecting sensor is located in the rear bumper.

Shift to the reverse gear to reverse the vehicle; afterwards, the radar detector can detect for obstacles behind the vehicle tail when the vehicle speed is lower than 5km/h.

If an obstacle is within the detecting range, the buzzer installed at the left rear of the vehicle will sound for alarming. If the obstacle is about 75cm away from the detecting sensor, the buzzer will alarm at higher frequency.

If the obstacle is about 30cm away from the detecting sensor, the buzzer will send out continuous alarms. Be much more careful at this moment.

Activating/deactivating

When the ignition key is at the M position and the transmission lever is shifted to the reverse gear, the buzzer beeps once, suggesting that the detecting system is activated.

Turn off the reverse radar by shifting the transmission lever off the reverse gear.



Note:

Ensure that the obstacle detecting sensor is not covered by dirt, rime and snow in winter and bad weather.



Note:

The sharp projections and small long objects cannot be detected by the reverse gear.

The ultrasonic interference sources around the radar system such as horn, motorcycle engine and some radio equipment (like walkie-talkie) will influence the detection and alarm of reverse radar.



Note:

The detecting range of the reverse radar, even if equipped, is limited; therefore, observe the environmental condition carefully behind the vehicle tail as well so as to ensure safety.

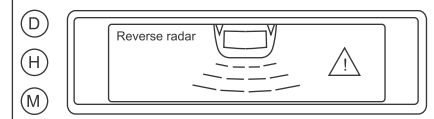

Reverse radar display

In terms of vehicle equipped with dotmatrix type multi-function display, see Page 75 for display of the distance of obstacle detected by the reverse radar.

During reversing, the distance of obstacle away from the vehicle tail can be displayed and indicated on the multi function display.

Do not move the vehicle backwards any more if three levels of short bars indicating for obstacles are lighted.



Note:

Though the vehicle equipped with dot-matrix type multi-function display can know the situation of obstacle through the display screen, but you still can not completely rely on the screen for reverse control.

REVERSE IMAGE*

2

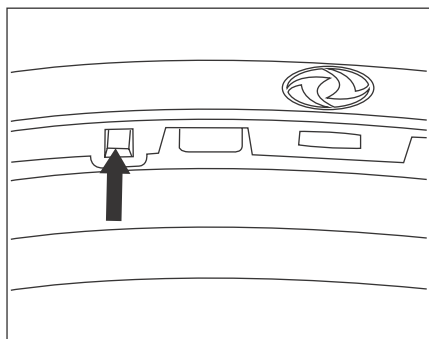

Reverse image

Reverse camera

The reverse camera is installed beside the trunk lid switch.

The reverse camera-recording function will be activated automatically when the shift lever is switched to the reverse gear.

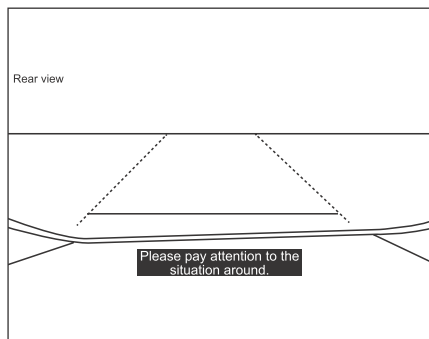

Reverse image display

The display will show the relative distance between the vehicle tail and the obstacle by colorful image. This system can help the driver to detect the relatively larger stationary obstacles to avoid vehicle scratch. However, the system cannot detect the obstacles at the corners on both sides of the bumper or the area below the bumper as well as those on the ground.

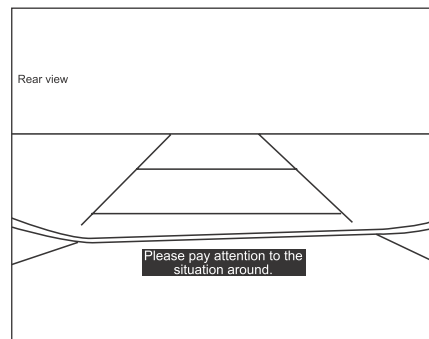

Green area: safety area where the obstacle is about 300cm away from the vehicle tail

Yellow area: warning area where the obstacle is about 150cm away from the vehicle tail

Red area: dangerous area where the obstacle is about 40cm away from the vehicle tail

**Danger:**

- The reverse image system can facilitate the drivers, but not substitute the correct reverse method. Before reversing, check the rear side for safety and reverse slowly.
- Due to the application of wide-angle lens, the distance seen from the reverse image system is different from the actual one and the objects will be distorted.
- Confirm that the trunk lid has been closed tightly during reversing.
- Do not cover any things on the reverse camera.
- Since the monitored area is limited, the corners on both sides of the bumper and the area below the bumper cannot be seen via the reverse image system.
- When cleaning the vehicle with high-pressure gun, do not apply high-pressure water spray around the reverse camera to prevent it from malfunction, firing or electric leakage due to water invasion into the system and condensation on the lens.

3 VEHICLE EQUIPMENT

VENT	104	CIGAR LIGHTER, ASHTRAY* & HANDLE*	111
AUTOMATIC A/C*	105	REAR SHELF.....	112
STORAGE DEVICE	108	TRUNK	113
INTERIOR LIGHTING & TRUNK LIGHTING.....	109	SUNROOF*	114-118
SUN VISOR & GLASSES BOX*	110		

*If installed on your vehicle

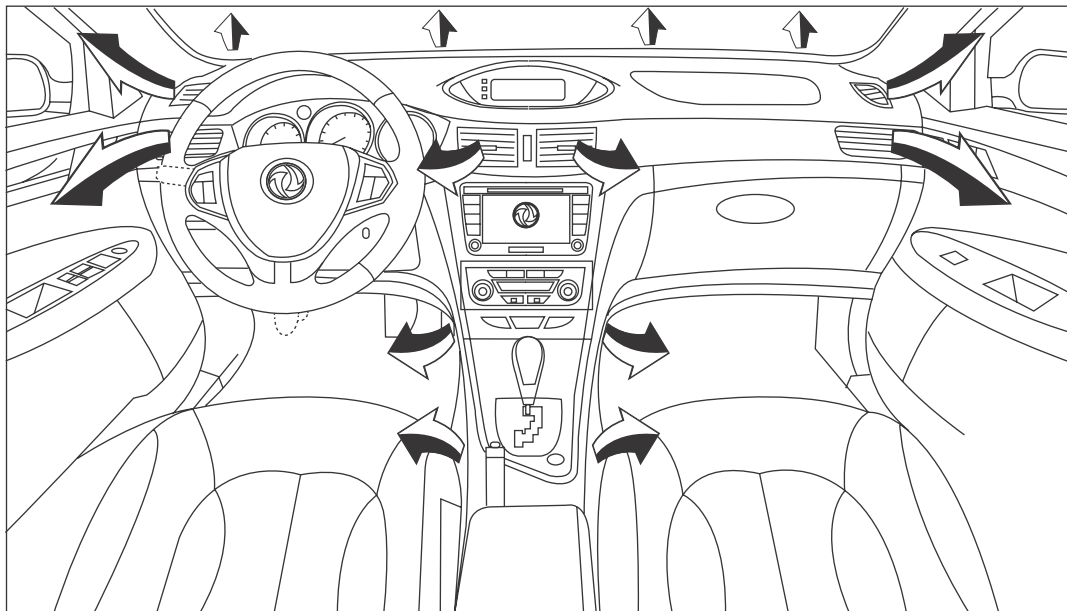
**Air inlet**

Please keep the air inlet grille damper and vent clean (removing foreign matters such as fallen leaves, snow grains), and the vent is in the right of front windshield bottom.

To ensure the normal cooling/heating effect of the rear seats, please do not block exhaust ports on both sides of trunk. It is recommended to keep a certain amount of air flow inside your vehicle.

Air outlet

The knob controlling the air outlet flow and the grille damper (which can be adjusted upwards, downwards, leftwards and rightwards) controlling the air direction are installed to the air outlet.

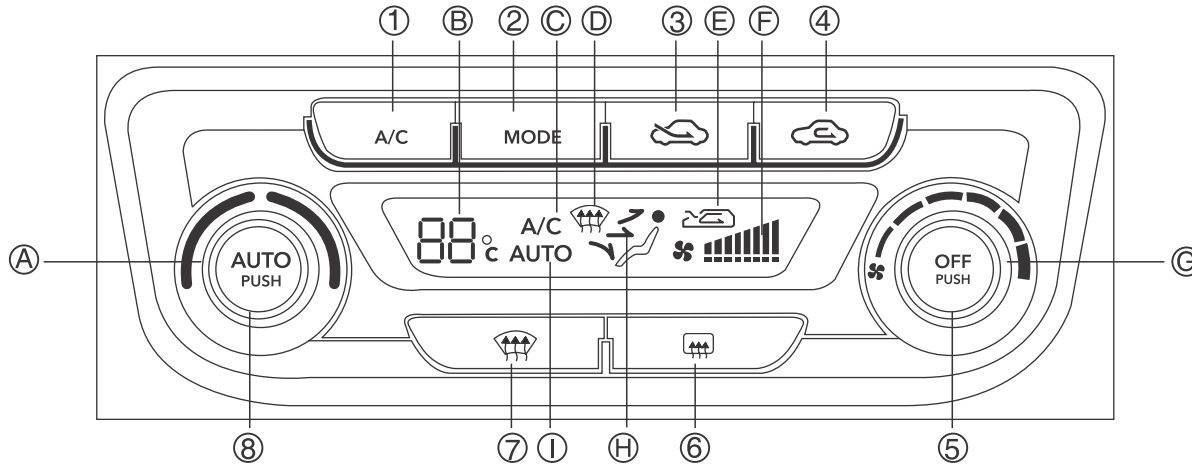

- Ⓐ Temperature adjustment knob
- Ⓑ Display of set temperature
- Ⓒ Refrigeration switch display
- Ⓓ Defrost mode display
- Ⓔ Internal & external air circulation display
- Ⓕ Air volume display
- Ⓖ Air volume adjustment knob
- Ⓗ Air distribution display
- Ⓘ Automatic mode display

- ① Refrigeration button (A/C switch)
- ② Adjustment button of air distribution
- ③ Selector button of external air circulation
- ④ Selector button of internal air circulation
- ⑤ System OFF button
- ⑥ Defrosting/defogging button of rear windshield
- ⑦ Defrosting/defogging button of front windshield & front side windows
- ⑧ Auto mode switch button

The system will adjust temperature and air volume inside the vehicle automatically depending on your choice.

Generally, setting automatic mode (pressing down **AUTO PUSH**) will keep the air conditioning in optimally comfortable condition.

AUTOMATIC A/C*

3

1-Temperature adjustment knob (A)

The system can adjust and display the set temperature.

To adjust or display the set temperature, turn the knob:

Turn counterclockwise: the temperature is decreased;

Turn clockwise: the temperature is increased.

2-Display of set temperature (B)

The display corresponding to the maximum heating request (higher than 32 °C): HI (high);

The display corresponding to the maximum cooling request (lower than 18°C): LO (low).

3-Adjustment button of air distribution (2)

Press down the control button **MODE** to change the air distribution, and the



circulation will be displayed on the display.



Note:

The comfortable temperature of cabin is related to the external conditions, so it may be different from the set temperature.

4-Air distribution display (H)



To central & side vents



To passenger foot



To windshield, front side window and passenger foot



To windshield glass

5-Refrigeration button (A/C switch) (1)

Press the control button **A/C** to start the refrigeration function. And the display will show **A/C**.

6-Automatic mode switch button (8)

Press the button **AUTO PUSH** to start A/C system, and the symbol **AUTO** will be shown on the display.

The following five functions can be managed automatically depending on the chosen temperature:

- Air volume;
- Cabin temperature;
- Air distribution;
- Refrigeration equipment operation;
- External air circulation.

It is recommended to open all air outlets.

To avoid the fogging of the interior vehicle in chilly or wet weather, it is recommended to apply the automatic mode.



Note:

Under automatic A/C mode, before the engine reaches the normal temperature, the air volume of automatic A/C will reach the comfortable requirements gradually.



The interior temperature may be lower (higher) than the comfortable temperature the moment when you enter into the vehicle. In this case, trying to reach the desired comfortable temperature by changing the set temperature is not feasible.

The system will use its maximum regulation and control capability automatically to compensate it as soon as possible.



7-Defrosting/defogging of front windshield & front side windows ⑦



When the function comes to work, the defrosting/defogging symbol will appear on the display: .

Pressing this button can achieve defrost/defog quickly, which, however, may influence air intake, air conditioning, air distribution and air volume.

Press the control button  or  again to quit the function.

8-Selection of internal & external air circulation ③ ④

Press the control button  to open the external air intake, and the display area ⑤ will display .

Press the control button  to close the external air intake, and the display area ⑤ will display .

9-Internal & external air circulation display ⑤

When maintaining other adjustments, closing the external air intake can isolate external odors or uncomfortable smoke, meanwhile, the set temperature can be reached as soon as possible. Open the external air intake to change the interior air or defog as required.

10-Defrosting/defogging of rear windshield ⑥

When the function is in operation, the symbol  will appear on combination instrument display.

This control key can be used to realize the rear windshield defrosting defogging quickly.

To avoid additional electricity consumption, this function can delay for turning off automatically.

11-Air volume display ⑥

The adjustment of air supply can be realized as follows:

Turn clockwise: the air volume is increased

Turn counterclockwise: the air volume is decreased

The air volume is displayed by filling the vertical bar gradually;

The maximum air volume is displayed as: .

12-Turning off A/C system ⑤

Press the button  to turn off A/C system, with no symbols shown on the display.



Note:

When the engine is not running, do not turn on the refrigeration and air volume switch to avoid excessive consumption of battery power.



WARNING

Internal air circulation for a long time may cause poor interior air.

STORAGE DEVICE

3

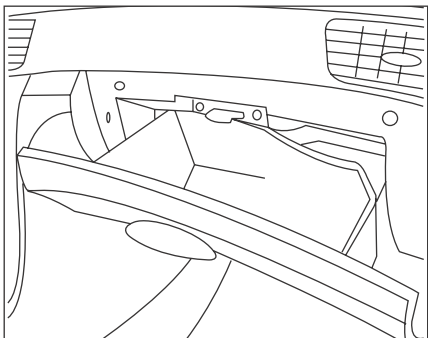

Glove box

Hold the handle and pull the cover backwards to open the glove box; and push the cover forwards to close it.

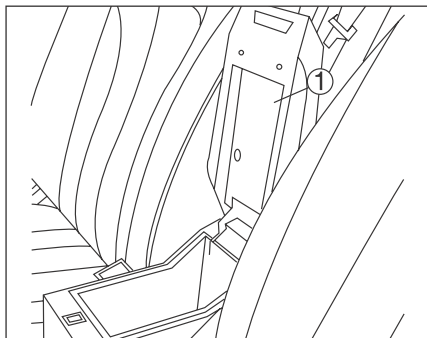

Central glove box

Open the central glove box cover ① from front to rear, and then the lower glove box is visible.



Note:

For safety concerning, close the glove box cover when driving.

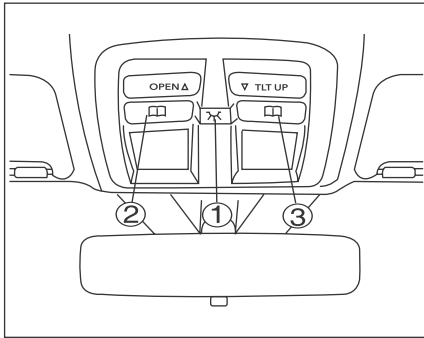

Interior front & rear roof lamps

Operation of the interior front & rear roof lamps:

① is the door operation-based lighting function switch. Press this switch and open the door, and then the roof lamp will be on; after the door is closed, it will be off after 10s delay. When the roof lamp is on during the delay, the roof lamp will be off if the door is locked by the remote controller. Press down this switch again to deactivate this function.

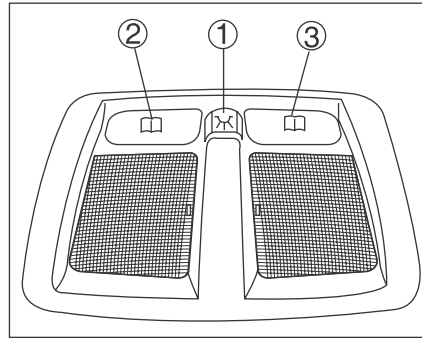

② & ③ are the switches of left/right reading lamps, after either of them is pressed down, the corresponding roof lamp will be on, and then the lamp will be off if the switches are pressed again. The reading lamps, if turned on, are not controlled by the delay off, and are still on even if the ignition switch is turned off, so pay attention to closing them timely once it is turned on to avoid excessive power consumption when the vehicle is stopped.

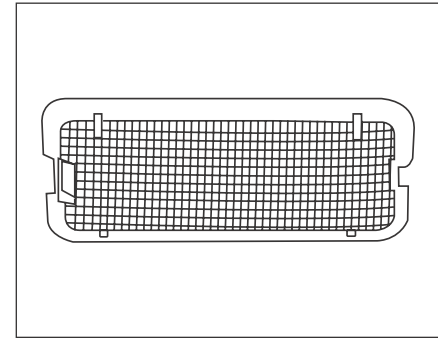

Trunk lamp

The trunk lamp will turn on automatically when the trunk lid is opened, and whether to turn off the ignition switch or not has no relation to the trunk lamp.

SUN VISOR & GLASSES BOX*

3

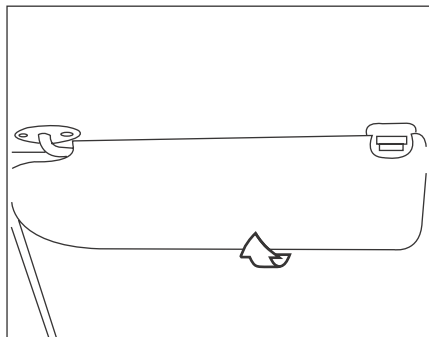

Sun visor

The left sun visor face has an interlayer for notes.

The right sun visor is equipped with a cosmetic mirror on the back.

The sun visor can be overturned. Turn it downwards for shielding the sun from the front to avoid dazzling.

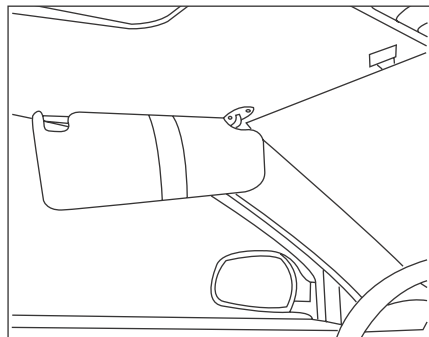

The sun visor can also be turned to the side door for shielding the sun from the side. Take the support shaft from the clip and turn the sun visor to the side window.

When getting on or off the vehicle, please verify that the sun visor has been placed to the original position.

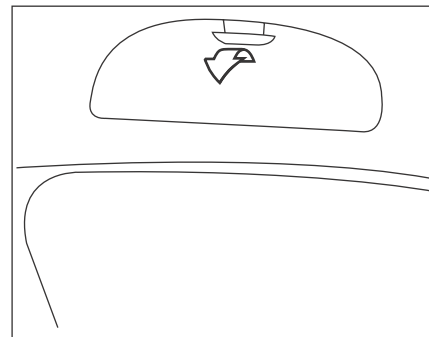

Glasses box*

The glasses box is on the left door frame at driver's side. Pull it downwards to open it up.



WARNING

Please do not use the cosmetic mirror when driving.

*If equipped

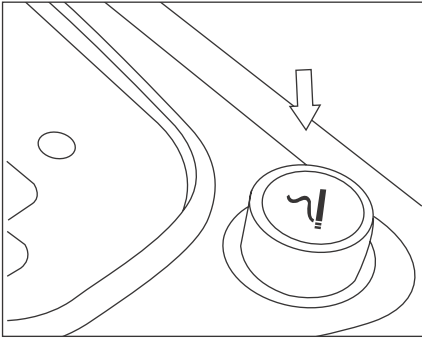

Cigar lighter

Cigar lighter is in the rear of transmission shift lever.

Press down the cigar lighter button; wait for a moment, and then the button will pop up automatically for lighting the cigar.

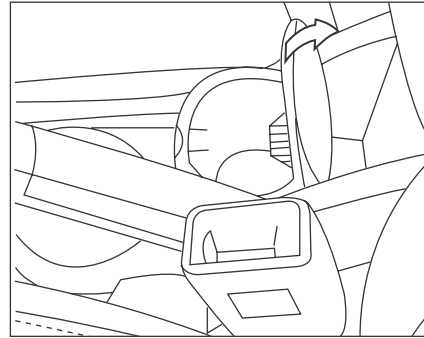

Removable ashtray*

Open the cover to use it.

When it is required to empty it, pull it upwards a little harder to take it out.

Ashtray installation

When installing it, the tray cover opening shall be forward and press it downwards a little harder to clamp it.

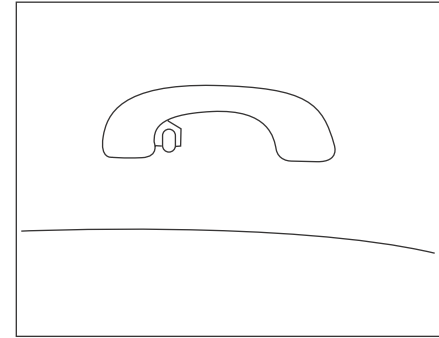

Handle*

The passenger seat door frame is provided with a handle.

The foldable handle offers a coat hook.



WARNING

The cigar lighter still works when the ignition switch is turned off; any person, especially the children are prohibited playing with the cigar lighter to avoid burns or fire hazard.



Note:

The storage box in front of the shift lever cannot be extracted for cleaning, for it is not be used as the ashtray.

* If equipped

REAR SHELF

3

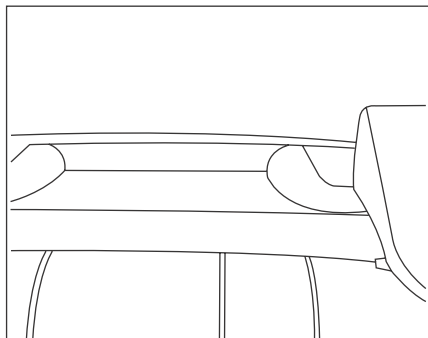

Rear shelf (S30)

The rear shelf behind the rear seats is stationary and only some light and soft items can be placed on it.

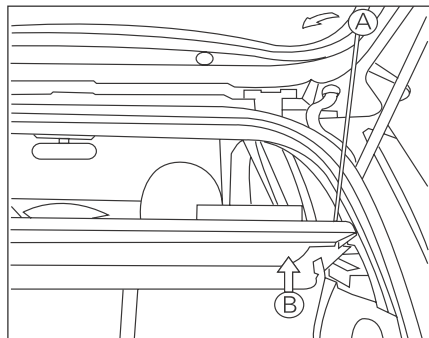

Rear shelf (H30, H30 CROSS)

The rear shelf behind the rear seats is removable. The rear part of the rear shelf can be synchronized with the liftgate by the connected sling, thus convenient for accessing the luggage.

To remove the rear shelf, disengage the sling from the hook (A), and lift up the rear part of the shelf for about 45°, and then push the shelf at the (B) fulcrum upwards to disengage the shelf fulcrum.

Reinstall it as per the reverse steps for removal.



WARNING

Do not place any hard or heavy items on the rear shelf, for they may turn to be dangerous projectiles during emergency braking or vehicle collision.

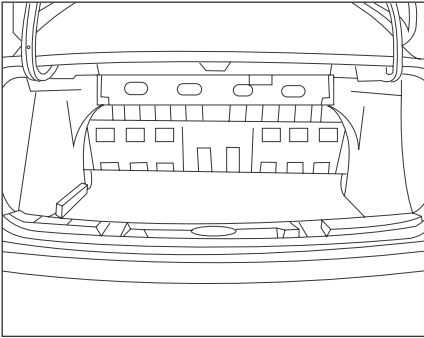

Trunk (S30)

The trunk bottom is flat and practical, and after folding the rear seats, the trunk will be connected for carrying larger luggage.

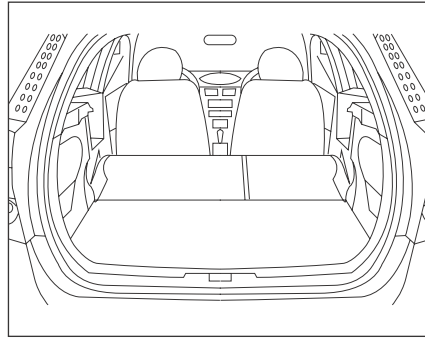

Trunk (H30, H30 CROSS)

The trunk capacity varies with the folding of the rear seats.

After removing the rear shelf and folding all rear seats, the trunk capacity reaches the maximum.

Both sides of the trunk are provided with glove boxes.



Note:

- For the safety of emergency braking, the heavy items should be placed near the seat backs.
- Before loading items into the trunk, please check for reliable firmness of the rear seat backrests.
- Take measures to fix the items, especially the hard and heavy ones.

SUNROOF*

3

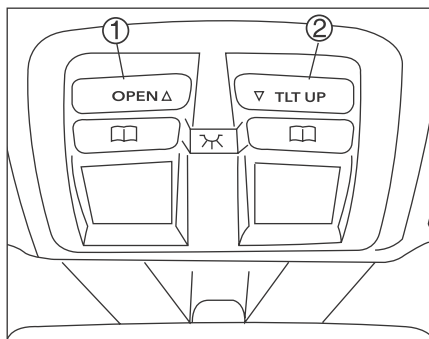

Control panel

- ① Slide backwards to turn on/slantwise to turn off the control button.
- ② Slide forwards to turn off/slantwise to turn on the control button.

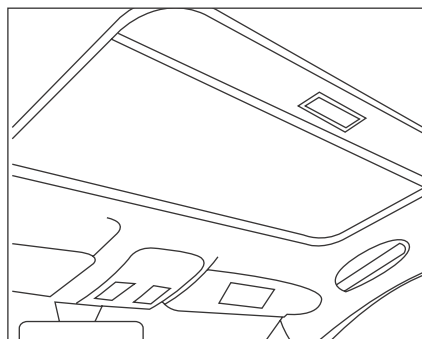

Slide to open/close the sunroof

Slide backwards for opening

Briefly press down the button ① (less than 0.5s), and the glass panel will drive the sunroof visor move to the maximum position automatically. During the glass panel sliding for opening, press down any button to enable the panel to stop at the current position;

Press and hold the button ① (more than 0.5s) for opening the sunroof by sliding, and then the glass panel will stop sliding immediately when the button is released.

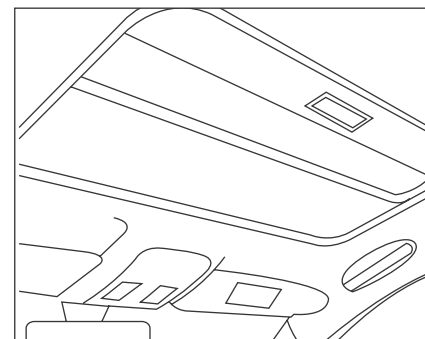

Slide forwards for closing

In case that the sunroof is opened, briefly press the button ② (less than 0.5s) and the glass panel will be closed automatically;

During the glass panel sliding to close, pressing down any button will enable the panel to stop at the current position;

Press and hold the button ② (more than 0.5s) to close the sunroof by sliding, and then the glass panel will stop sliding immediately when the button is released.

The sunroof visor should be closed by pulling manually.

* If equipped

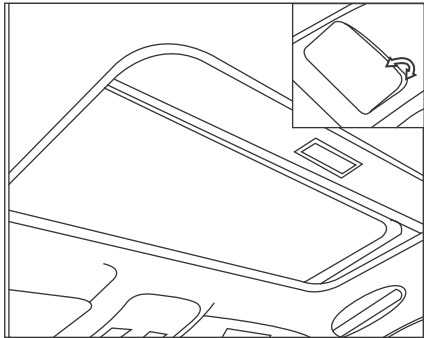

Slantwise open/close the sunroof
Slantwise open

In case that the sunroof is closed, press down the button ②, and the rear part of glass panel will be opened slantwise, and the sunroof visor can be opened by pulling backwards manually.

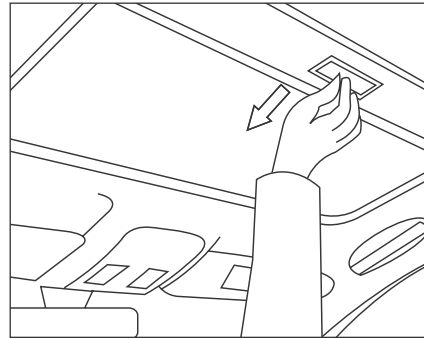

Slantwise close

In case that the sunroof is opened, press down the button ①, and the glass panel is lowered down for closing. The sunroof visor should be closed by pulling back manually.

Anti-pinch function

If being held down by obstacles during closing, the sunroof will return to the completely open state immediately, afterwards, press down ① or ② to operate the sunroof again.

The anti-pinch function is only applicable to the short press mode but not the press-hold mode.

During high speed driving, the air resistance may cause that the sunroof cannot be closed during its automatic closing, in this case, press and hold the button ① or ② to close the sunroof.

3



WARNING

When the automatic anti-pinch function detects out the obstacle, there still remains certain forward inertia, please ensure that hands, heads, bodies and other parts of all passengers are not out of the sunroof.

* If equipped

SUNROOF*

3

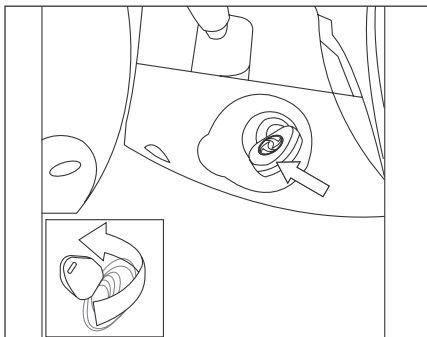

Auto-closing function

When the sunroof is at any opening position, the sunroof glass panel will be closed automatically 3 s after turning off the ignition switch. During its closing, the sunroof closing will be stopped immediately if either button ① or ② is pressed, press down the button ② again to continue the closing.

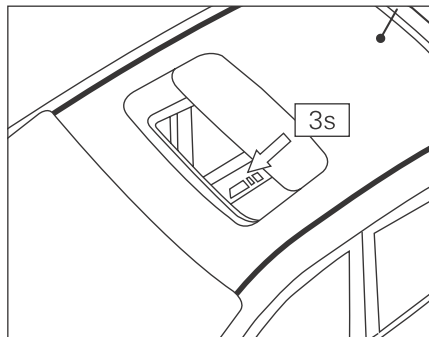

The anti-pinch function is effective during automatic closing and the anti-pinch function will come into work for five times, that is, returning to the original position if obstructed, continuing to close afterwards and then returning again if obstructed again. After repeated 5 cycles for returning, the function will stop automatically.

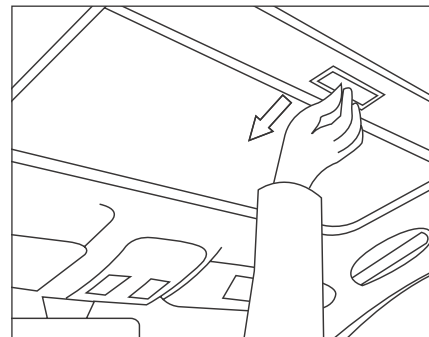

Sunroof visor

The opening/closing of the sunroof visor can be controlled by pushing/pulling manually and can be stopped at any position.



WARNING

When the automatic anti-pinch function detects an obstacle, there still remains certain forward inertia, please ensure that hands, heads, bodies and other parts of all passengers are not out of the sunroof.

*If equipped

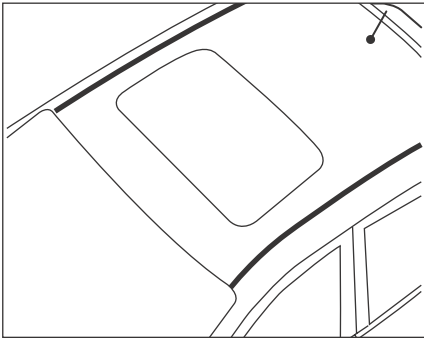
**Special note**

Do not open the sunroof when it is raining or vehicle is being cleaned.

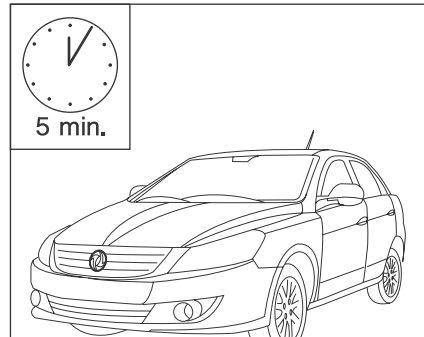

The sunroof can only be opened upon driving for 5 min at least after raining or vehicle cleaning (in order to dry stagnant water on the roof by air).

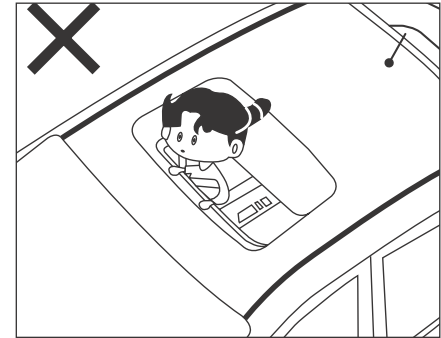

Do not put heads or hands out of the sunroof when driving.

SUNROOF*

3

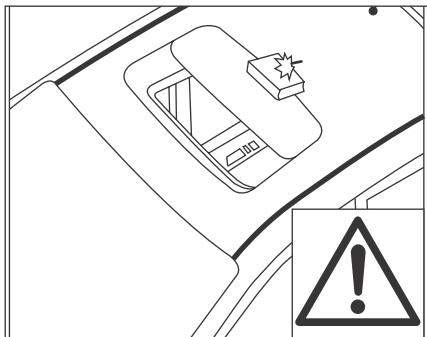

Before opening the sunroof, please ensure that no obstacle on the roof affects the glass panel movement.

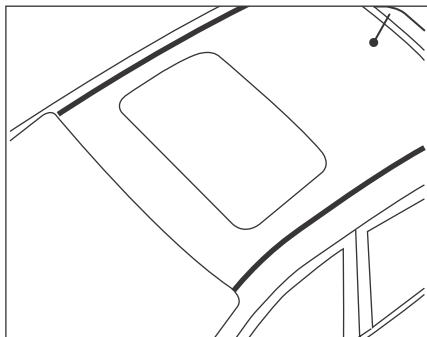

Sunroof initialization

When the sunroof has abnormalities, perform the sunroof initialization firstly.

Steps: Press and hold the button ② for 7s so that the sunroof is tilted completely, the sunroof shakes for up/down adjustment indicate that the initialization has been completed.

If the faults are still unsolved, please contact either Dongfeng Franchise Store or IKCO authorised representatives.



WARNING

Before opening the sunroof, please ensure that no obstacle on the roof affects the glass panel movement.

Do not open the sunroof when the roof is accumulated with snow or is frozen.

4 MAINTENANCE

FLUID APPLICATION REGULATIONS	120
FLUID LEVEL & CHECK	121
INTERIOR MAINTENANCE.....	125
BODY MAINTENANCE.....	127

FLUID APPLICATION REGULATIONS

The special high-quality fluid can keep the vehicle under normally technical condition effectively, please pay special attention to the quality of the engine oil. Do not use the non-designated fluid, or adverse consequences will be caused to the vehicle.

For specific types and consumption, refer to Warranty Manual.

4

Fuel additives

The quality of fuel and its additives affects the running condition, performance and service life of the engine directly. The fuel additives can be used to prevent corrosion, clean fuel system and prevent the engine from carbon deposits etc., so it is recommended to use the fuel with additives.

If the fuel without additives is used frequently, or faults such as hard engine start, unstable idling, difficult acceleration, power performance reduction etc. occur, add the appropriate additives when adding the fuel.

It is recommended to use fuel additives verified by us, all of which can be bought either from Dongfeng Franchise Store or

IKCO authorised representatives, who will also inform you of the correct using methods.

Do not use any fuel additives without our verification.



Note:

1. In extremely freezing weather, select the engine oil of 5W/30 A5B5, 5W/30 SL (SJ) grade or above verified by us.
2. In extremely freezing weather, select the coolant with superior antifreeze properties verified by us.
3. Select the windshield cleaning fluid according to the vehicle ambient temperature to avoid freezing. Please contact either Dongfeng Franchise Store or IKCO authorised representatives for fluid purchase.

(N6A 10FX3A PSA ENGINE)

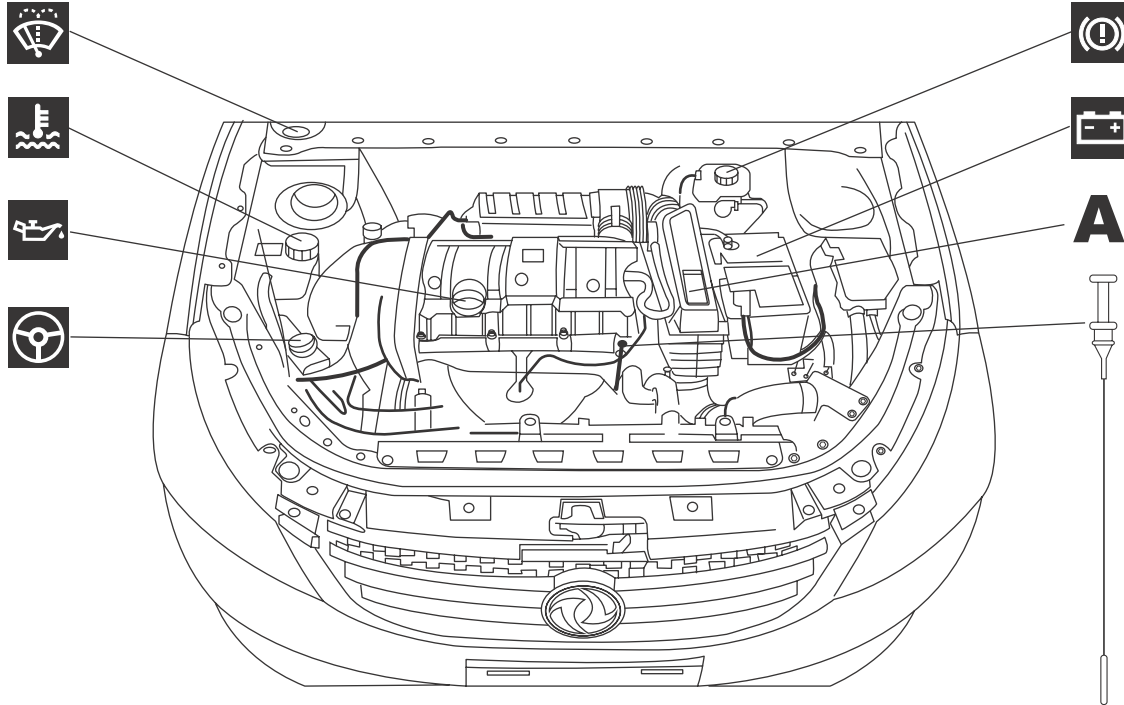

4

FLUID LEVEL & CHECK



Windshield cleaning fluid reservoir

Capacity: 3L

In order to achieve the best washing effect and utilization safety, please use cleaning fluid verified by us. Please add the cleaning fluid slowly.



Note:

When the ambient temperature is lower than 0°C, antifreeze cleaning fluid should be used.



Power steering fluid*

Capacity: 1.5L

When the engine is stopped, check the fluid level.

The level of the fluid reservoir should be between the maximum (MAX) and the minimum (MIN) markings.



Note:

Running without fluid is prohibited in any cases to avoid damage to the power steering pump.



Add the engine oil

For engine oil grade and capacity, see Warranty Manual; do not use other additives.



Coolant

Cold engine: The fluid level should be between the maximum (MAX) marking and the minimum (MIN) marking of expansion tank.

Hot engine: After the engine is stopped, wait for 15 minutes or till the temperature is less than 100°C, open the tank cover slowly by hands wrapped with the cleaning cloth to avoid burns.

If the added coolant is more than 1L, have the cooling system checked at Dongfeng Franchise Store or IKCO authorized representatives.



Brake fluid

When the level of brake fluid is too low and up to the DANGER position, the low brake fluid level warning lamp will be on.



WARNING

Check the coolant when engine is cold to avoid burns.

For the check of fluid level, see Page 127.



Battery (see Page 143)

Spec.: 12V



Air filter

Clean and replace the filter element as specified in Warranty Manual.



Note:

If the coolant needs to be added frequently, it indicates that the cooling system has faults, check to find out the causes as soon as possible. The coolant should be refilled or replaced at Dongfeng Franchise Store or IKCO authorized representatives.



Note:

When the vehicle ambient temperature is below -30°C, the coolant should be replaced by the one with stronger low temperature resistance at local Dongfeng Franchise Store or IKCO authorized representatives.

Engine oil dipstick

After the engine is stopped on the level ground for 10 minutes, check the engine oil level with a dipstick. The fluid level should be between the upper limit marking and the lower limit marking. The engine oil level should be checked regularly.

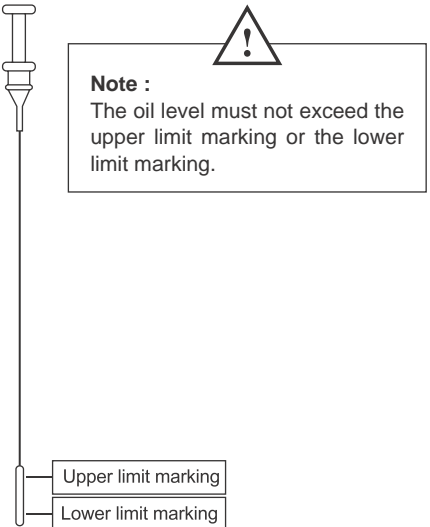

ATF dipstick *

The automatic transmission fluid should be checked either at Dongfeng Franchise Store or IKCO authorised representatives regularly.

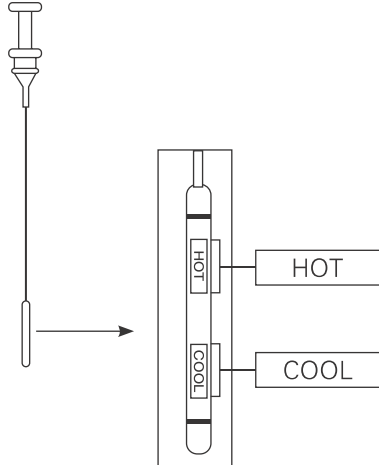

WARNING 

When the engine hood is opened for check, if the engine is hot, please be cautious to avoid any injuries, because the fan may run at any time even the engine is stopped.

FLUID LEVEL & CHECK

4

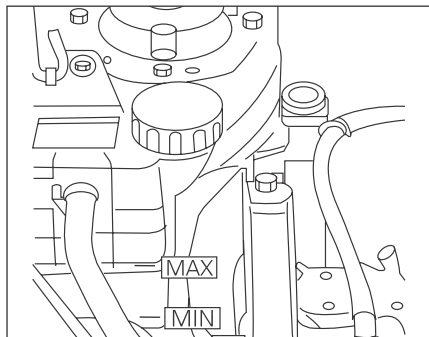

Coolant expansion tank

The level of the coolant should be checked when the engine is cold. The coolant level should always be between the minimum (MIN) and the maximum (MAX) markings. The content of antifreeze in the coolant should be proper enough to remain the coolant in fluid form at low temperature. The coolant should have corrosion resistance and high-temperature stability.

In order to maintain the coolant performance, the coolant should be replaced every two years in chilly weather.

The coolant should be changed either at Dongfeng Franchise Store or IKCO authorised representatives.

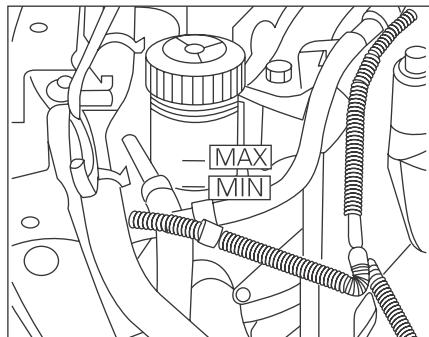

Power steering fluid reservoir*

Check the fluid level when the engine is stopped.

The fluid level in the reservoir should be between the minimum (MIN) and the maximum (MAX) markings.

Running without fluid is prohibited in any cases to avoid damage to the power steering pump.

For oils: see Warranty Manual.



Note:

The coolant with superior antifreeze properties should be selected for application at -30°C.

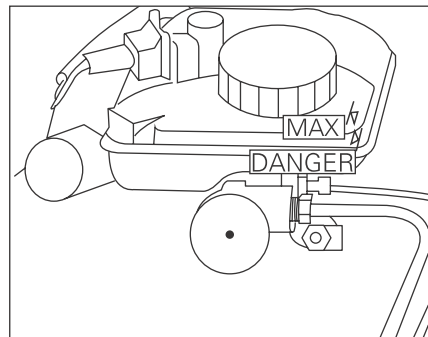

Brake fluid reservoir

The brake fluid level should be checked regularly, and should be between the DANGER and the maximum (MAX) markings, close to the maximum marking as far as possible.

If the brake fluid level warning lamp turns on when driving, park the vehicle for inspection and seek help either from Dongfeng Franchise Store or IKCO authorised representatives.

In order to maintain a good braking performance, the brake fluid should be replaced every two years.



Note:

If the brake fluid level is lowered down obviously in a short time, the brake system may have leakage. Have it repaired at Dongfeng Franchise Store or IKCO authorized representatives immediately.

**Note:**

Before clearing stains, the dust must be removed firstly.

Various solvents have more or less corrosive effect on the interior synthetic materials, so they should be used with caution and as little as possible.

Generally, aqueous solution with soap and surfactant should be used whenever possible to clear stains on fabrics or synthetic leather. It is recommended to use a piece of clean, soft, and wet cloth for wiping repeatedly.

Wipe off stains

In any cases, clear stains quickly as per the product instructions.

In case that it is difficult to remove the stains, contact either Dongfeng Franchise Store or IKCO authorised representatives.

Before clearing, it is recommended to perform test at the less conspicuous position or on samples.

Stains of ballpoint pen or lipstick can be cleared by denatured alcohol.

Asphalt stains can be cleared by the special cleaning agent.

Stains of chocolate and sugar can be cleared by commercial ammonia solution.

Recommendations:

Exposure to the sun for a long time will damage the body interior; it is recommended to install shading devices onto the front windshield and the rear shelf to avoid damage from UV.

Light interior

For the light interior, pay special attention to clearing the corresponding material with special cleaning agent to avoid color difference. Do not leave the stains stuck on the interior surface for a long time but remove them timely.

If a large area of surface stains needs to be cleaned or subject to interior care, have it performed either by Dongfeng Franchise Store or IKCO authorised representatives or professional automotive care center.

INTERIOR MAINTENANCE

Clear the interior (such as the interiors, plastic parts, seats etc.) dust and dirt frequently with a vacuum cleaner or duster, and wipe off the dirt on nylon or leather items with a piece of clean and soft cloth soaked in soft soap, and dry them with the soft cloth.

To maintain the appearance of leather, please note the relevant requirements of manufacturer, for some protective agents may have chemicals damaging or corroding the seat fabrics. Wipe off the instruments with a piece of lightly wet and soft cloth.

4



Warning

- Do not wipe with any benzene, diluent or similar fluid.
- Small dirt particles will wear the leather surface and cause damage, thus, clear them immediately.
- Do not use leather soap, wax polishing agent, engine oil, cleaning fluids, solvents, detergents or cleaning agent with ammonia, because they will weaken the leather natural luster.
- Do not use fabric protective agent without manufacturer's recommendation.
- Do not use the cleaning agents for glass and plastic to clean the instrument to avoid any damage.

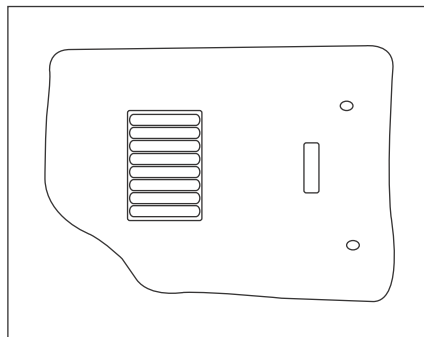

Foot pad (optional quality)*

Using the genuine Dongfeng delicate foot pad will extend the service life of the interior carpet and make the interior cleaning easier.

The foot pad should be applicable to the vehicle whichever is used, and should be fixed correctly and reliably to avoid interfering pedal operations.



Warning

If the unfixed foot pad is used, its sliding movement will interfere with the operation of clutch, accelerator and brake pedal, thus serious accidents may occur.

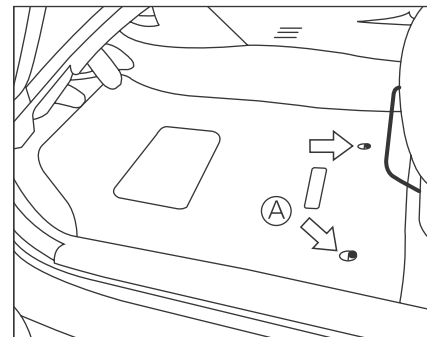

Fixing of foot pad (on driver's side)

This kind of vehicle is provided with front foot pad retaining clips (A) to fix the foot pad. The clips should not be covered or be used for other purposes in any cases.

The Dongfeng delicate foot pad is specifically designed for this vehicle, and the metal snap ring is used for fixing the foot pad.

When laying the foot pad, please put it in the center of foot floor, and pass the metal snap ring through the carpet clip for positioning.

The foot pad position should be checked for movement regularly.

Do not wipe the body drily

Do not wipe the painted surface and plexiglass surface (such as lampshade etc.) with gasoline, kerosene, trichlorethylene, strong alkali water, alcohol etc.

Body cleaning

To maintain a good painted surface, it is necessary to clean the body frequently but avoid strong sunshine or too low temperature.

Bird feces, insect secretions, resin and other matters having strong corrosion should be cleared as soon as possible.

Or else, their damage to painted surface will be speed up in hot days.

In any cases, wash the body with plenty of water and wipe it clean with chamois.

After washing, brake the vehicle for several times when driving to dry the brake friction pair.

Wipe windshield & door window

Do not use silicone-based products.

To achieve a high quality wiping effect, please use the cleaning fluid supplied either by Dongfeng Franchise Store or IKCO authorised representatives.

Paint polishing

It is recommended to perform paint polishing in winter after the body is completely cleaned and dried.

Polish with fluid or emulsion polishing agents.

Wipe the exterior trims & light alloy

Wash them with soapy water or water with a little of detergent or cleaning fluid, then flush them with plenty of water. To maintain the glossiness of metal surface, wax it after drying.

Asphalt stains on the body

Clear the stains as soon as possible, and do not scrape it or use gasoline or fabric detergent, but the special cleaning fluid should be used.

VEHICLE MAINTENANCE

Asphalt & gasoline stains on bumper

The stains should be cleared with special cleaning agents.

Even though the vehicle adopts corrosion resistant materials and undergoes the anti-corrosion treatment, after the vehicle is stopped or driven for a period of time, especially after being driven frequently on road unfrozen by salt for a period of time, the engine compartment and the body underbody should be cleaned and protected again.

4



Note:

If the high pressure washing machine is used, do not direct the sprayer to the rubber protective parts of transmission and steering mechanism and other components, and do not spray directly into the exterior trim, canopy seams, radiator and engine compartment.

Typically, the vehicle corrosion is resulted from the following two reasons:

- ① Moisture accumulated in the body holes. The sludge and antifreeze salt in the vehicle lower gaps is more likely to accumulate moisture to make those parts more vulnerable to corrosion.
- ② The peeling off of protective paint and protective layer in the body surface and the underbody.

Through some simple regular maintenance, your vehicle will be free of corrosion:

Repair immediately in case of paint peeling off or scratches;

Check and clean the doors and drain holes of body underbody;

Check the humidity of the floor covers, since the carpets and floor mats will accumulate moisture for a long time, especially in winter, thus causing floor corrosion;

Clean the underbody with high pressure spray gun but carefully protect the ABS wheel speed sensor and wires connected to each wheel;

The anti-corrosion coating at the vehicle lower side should be checked and repaired regularly.

5 OPERATIONAL RECOMMENDATIONS

FUEL-SAVING MEASURES	130	BULB REPLACEMENT	139
OPTIONAL ELECTRICAL ACCESSORIES	132	TOWING	146
FUSE	133	WHEEL REPLACEMENT	147
BATTERY	137	TYRE	150
START BY EMERGENCY BATTERY	138	SAFETY TIPS	152

FUEL-SAVING MEASURES

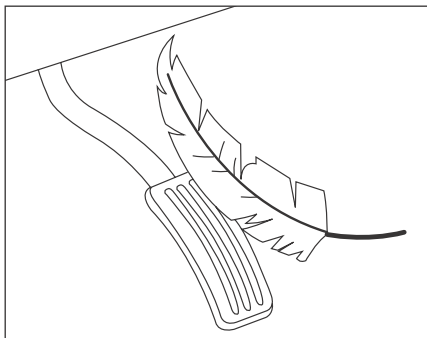

5 Loading goods onto the vehicle reasonably

Do not place useless items on the vehicle, for their weight will waste fuel.

Driving should be gentle and stable.

The following basic essentials should be remembered:

Starting: There is no need of pre heating the engine before starting. Start slowly and accelerate gradually.

Driving: Keep the appropriate engine speed: higher than 2,500r/min during normal driving and higher than 3,000r/min during upshifting. Avoid the engine running at too low speed. The vehicle speed when driving should be stable to avoid frequently sudden braking. Make proper preparation for changes in traffic conditions in advance to avoid flat footed.

Control the vehicle speed

When the vehicle speed exceeds the economical speed (60-90km/h), fuel consumption will increase significantly with the increased speed.

Organizational driving

Avoid driving in a short distance. After the start, fuel consumption in the first kilometer is more than twice of the normal conditions, because the engine has not yet reached the optimum working temperature.

Driving in the urban area is not helpful for fuel saving, thus, choose an appropriate route for highway driving and avoid crossing the heavy traffic area if possible.

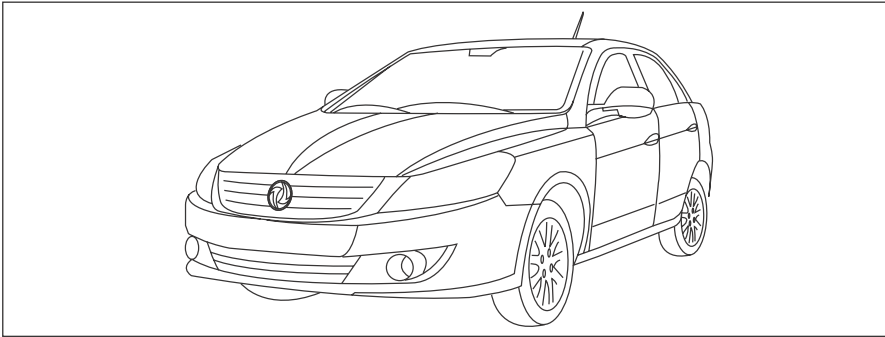

Save fuel & reduce emission

Fuel saving is not completely determined by the vehicle design and its technical characteristics, but also related to your use.

The following measures can help you to reduce fuel consumption:

- Keep your vehicle in good working condition;
- Comply with the service and maintenance rules specified by us;
- Apart from overhauling and lubricating oil & coolant replacement etc., the working conditions of components affecting the fuel consumption mostly should be checked regularly.

Adjust the engine

Check the main components of ignition system and fuel supply system annually at least.

Ignition system

Keep the correct spark plug clearance.

Fuel supply system

Check the mechanical connection conditions of fuel supply system, and check the positions for oil leakage.

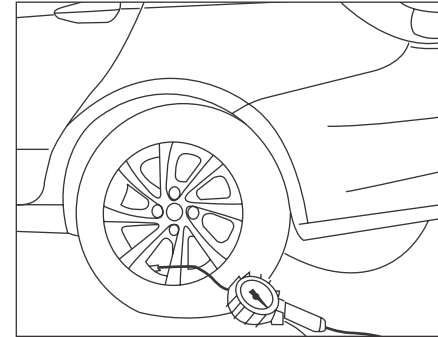

Check the tyre pressure

Check it weekly, and the insufficient tyre pressure will increase the wheel rolling resistance, thus the fuel consumption will be increased.

Air filter

The filter element blockage will decrease the engine air intake efficiency, thus, the element should be replaced regularly as the interval specified in the Warranty Manual.

OPTIONAL ELECTRICAL ACCESSORIES

Precautions for optional electrical accessories

Before installing electrical devices or accessories, please consult either with Dongfeng Franchise Store or IKCO authorised representatives.

Some electrical accessories (high-power sound system, xenon lamp, anti-theft device, wireless phones etc.) or their installation methods and operation may cause adverse consequences or malfunction.

For any malfunction or negative consequences caused by any electrical accessories which are not supplied by us or not installed either at Dongfeng Franchise Store or IKCO authorised representatives as required, and also for all losses resulting from hereto, our company will not be liable for compensation.

Fuse box

There is a fuse box at the lower left of instrument panel and in the engine compartment respectively.

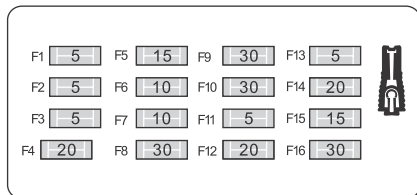
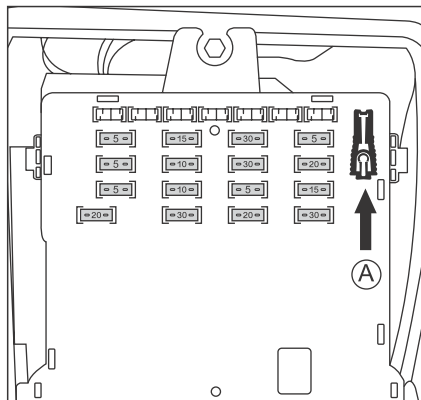

Open the cover at the lower left of instrument panel to access the cabin fuse box.

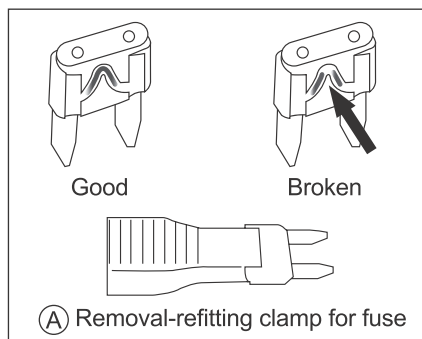

Fuse replacement

Before replacing the fuse, find out the causes of faults and troubleshoot them correspondingly. Number of each fuse is marked on the fuse box, and the unnumbered fuse is for spare.

Fuse at the same amperage (in the same color) should be used to replace with the damaged fuse.

FUSE

Number of cabin fuse box

No.	Capacity	Fuse functions	Type
F1	5A	Right front position lamp, left rear position lamp, left license plate lamp, right license plate lamp	Mini
F2	5A	Cab backlight	Mini
F3	5A	Left front position lamp, right rear position lamp	Mini
F4	20A	Combination instrument, diagnostic instrument, automatic transmission control module, anti-theft controller, multi-function display, hazard warning lamp switch, radio & CD player	Mini
F5	15A	Reversing lamp switch (MT), gear selector switch (AT), ABS, multi-function display, diagnostic instrument, mode selector switch, combination instrument, brake lamp switch, anti-theft controller	Mini
F6	10A	Airbag unit	Mini
F7	10A	Rear fog lamp	Mini
F8	30A	Cigar lighter	Mini
F9	30A	Rear window heating, rearview mirror heating, DFF indicator lamp	Mini
F10	30A	Left rear power window, front window relay, sunroof control module, electric rearview mirror adjustment	Mini
F11	5A	Front roof lamp, rear roof lamp, trunk lamp	Mini
F12	20A	Front wiper, door unlocking, trunk unlocking	Mini
F13	5A	Combination instrument (charging indicator lamp), radio & CD player, sunroof control module	Mini
F14	20A	Front wiper	Mini
F15	15A	Fuel pump	Mini
F16	30A	Right rear power window	Mini

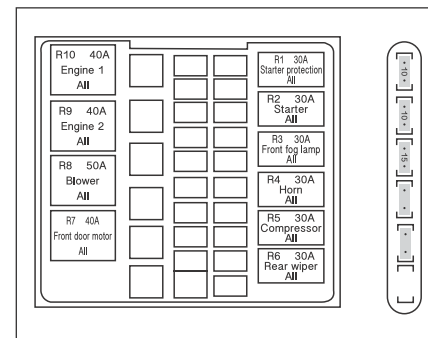
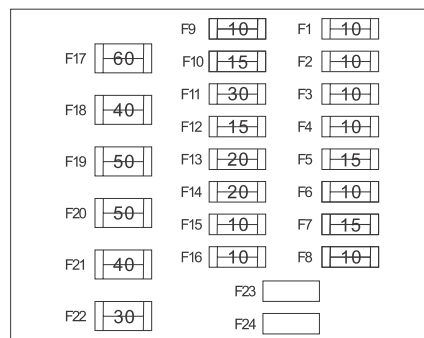
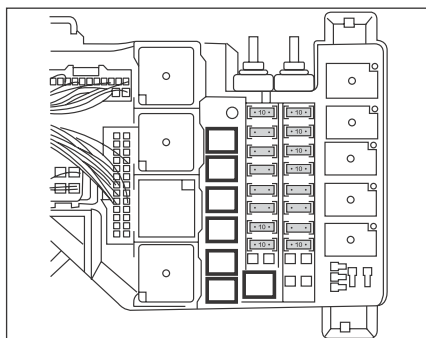

Engine compartment fuse box

The engine compartment fuse box is beside the battery, open the fuse box cover to access the fuse.

After the operation, note to close the fuse box cover.

The corresponding fuse instructions are provided on the fuse box cover.

5

No.	Capacity	Relay functions	
R1	30A	Starter protection	Micro
R2	30A	Starter	Micro
R3	30A	Front fog lamp	Micro
R4	30A	Horn	Micro
R5	30A	Compressor	Micro
R6	30A	Rear wiper	Micro
R7	40A	Front door motor	Mini
R8	50A	Blower	Mini
R9	40A	Engine 2	Mini
R10	40A	Engine 1	Mini

FUSE

Number of engine compartment fuse

No.	Capacity	Fuse functions	Type
F1	10A	Left front high beam	Mini
F2	10A	Right front high beam	Mini
F3	10A	Left front low beam	Mini
F4	10A	Right front low beam	Mini
F5	15A	ECU	Mini
F6	15A	Ignition coil	Mini
F7	15A	Engine	Mini
F8	10A	Horn/ignition switch	Mini
F9	10A	ECU	Mini
F10	15A	Fuel pump	Mini
F11	30A	Engine	Mini
F12	15A	ABS valve	Mini
F13	20A	ABS pump	Mini
F14	20A	Front fog lamp	Mini
F15	10A	Brake lamp	Mini
F16	10A	Compressor	Mini
F17	60A	Cooling fan	JCASE
F18	40A	Ignition switch	JCASE
F19	50A	Cabin power	JCASE
F20	50A	Cabin power	JCASE
F21	40A	Blower	JCASE
F22	30A	Front door motor	JCASE
F23	TBD	Reserved	Mini
F24	60A	EPS controller	JCASE
F25	TBD	Reserved	ATO
F26	TBD	Reserved	ATO

Battery: 12V

Battery removal

Remove the battery from the negative electrode.

Battery refitting

Connect the battery from the positive electrode.



Note:

- Check the battery electrodes and cable joints for cleanness, and if they are corroded to be copper sulfate, loosen and wipe off them. The cable joints must not be removed when the engine is running.
- In case that two cable joints are not removed, do not charge the battery with the external power.
- Avoid air vents of the battery being blocked.

Battery inspection

Have it checked either at Dongfeng Franchise Store or IKCO authorised representatives regularly.

Charging

When the dim lamp lighting, hoarse horns or powerless engine start occurs, the battery must be removed for charging by the charger.

Have the battery charged either at Dongfeng Franchise Store or IKCO authorised representatives.

In case of non-use for a long period

When the vehicle is not driven for more than one month, the battery negative electrode should be disconnected.

Charge the battery monthly, because no charging for a long period will cause the battery failure.



Note:

When the battery negative electrode is connected again, the systems such as clock, date, radio accessing etc. should be set again.



WARNING

Never make the battery close to the fire or sparks (avoiding explosion).

The battery contains dilute sulfuric acid with strong corrosion, so pay attention to protecting the exposed skin during handling.

Once it contacts the skin, flush it with plenty of water immediately, and go to the nearest medical facility for examination and treatment as soon as possible.

START BY EMERGENCY BATTERY

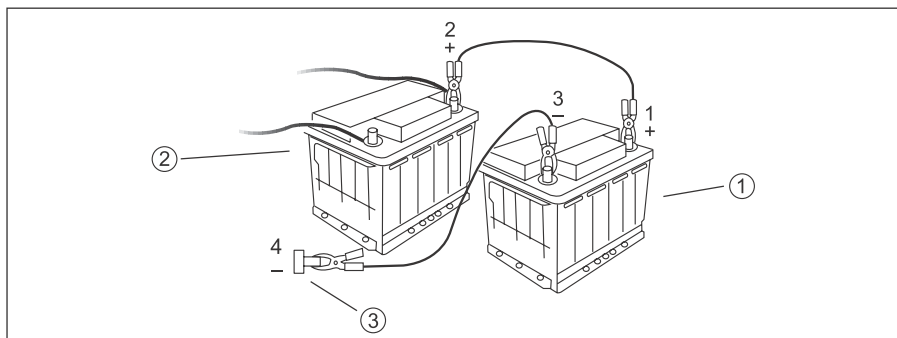

5

① **Emergency battery**

② **Breakdown vehicle battery**

③ **Ground (metal) point of breakdown vehicle**

When the battery power loss occurs, the emergency battery or the battery of breakdown vehicle can be used to help to start the engine. To avoid the risk of explosion, please connect the battery as follows.

Check terminal voltage of the emergency battery (12V)

- Keep two contacts of breakdown vehicle unchanged. When the relief vehicle battery is used, the engine should be stopped and the two

vehicles should not contact with each other.

- Connect the battery wires in the specified order as shown above, and the clips should be clamped (avoiding the sparks).
- Start the engine of relief vehicle and make it run at higher speed for about 1 minute.
- Start the breakdown vehicle.



Note:

During the operation, do not touch the metal part of the clip. Do not lean on the battery to avoid personal injuries.

Remove the wires in the sequence reverse to the connection and avoid short circuit.

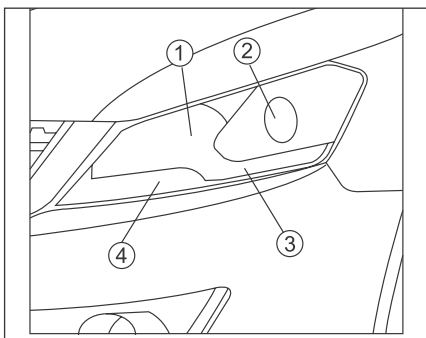

Headlamp

- ① High beam
- ② Low beam
- ③ Position lamp
- ④ Turn signal lamp



Note:

It is normal that the inner surface of headlamp will appear a thin layer of water vapor in some application conditions.

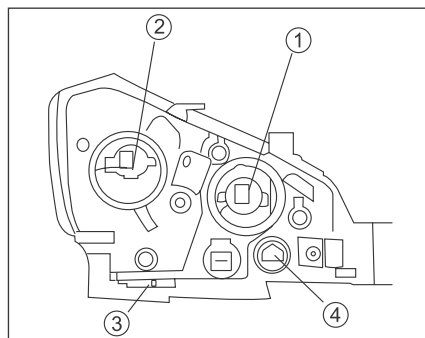

① High beam (H7/55W)

If the right front high-beam bulb is broken, turn counterclockwise the dust cover to remove it and pull out the plug, press the head of steel clip to detach it from the hook, and then remove and renew the bulb. Install it in the order reverse to the removal.



Note:

The lamp bulge should be aligned with lamp holder notch. Have the damaged left front high beam bulb replaced at Dongfeng Franchise Store or IKCO authorized representatives.

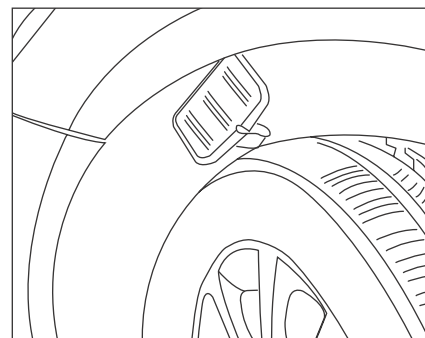

② Low beam (H7/55W)

Turn the steering wheel to the limit in the opposite of the low beam needed to be replaced; open the movable cover (pressing the clip and pulling it backwards) in front of front fender; stretch the hand forward from the movable cover opening, turn counterclockwise the dust cover to remove it and pull out the plug, and press the head of steel clip to detach it from the hook, and then remove and renew the bulb. Install it in the order reverse to the removal.



Note:

The lamp bulge should be aligned with lamp holder notch.

BULB REPLACEMENT



Note:

Halogen bulb should be replaced several minutes after being turned off till the bulb is cooled, do not touch the bulb with hands directly and the bulb can be wrapped by a lint-free cloth.

5

To avoid damaging the headlamp lampshade, only the bulb with low UV can be used.

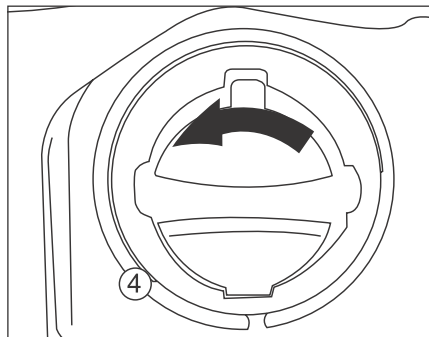

③ Position lamp (LED)

When this lamp has faults, have it replaced either at Dongfeng Franchise Store or IKCO authorised representatives.

④ Front turn signal lamp (PY21W)

If the bulb of the right front turn signal lamp is damaged, turn the lamp holder counterclockwise directly to remove it, and press the bulb inward gently for removal and replacement.

Reinstall in the sequence in reverse to the removal and check for proper installation. If the bulb left front turn signal lamp is damaged, have it replaced either at Dongfeng Franchise Store or IKCO authorised representatives.

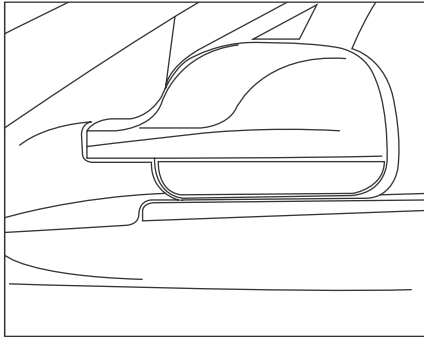

Side turn signal lamp (W5W)

When this lamp has faults, it is recommended to have it replaced either at Dongfeng Franchise Store or IKCO authorised representatives.

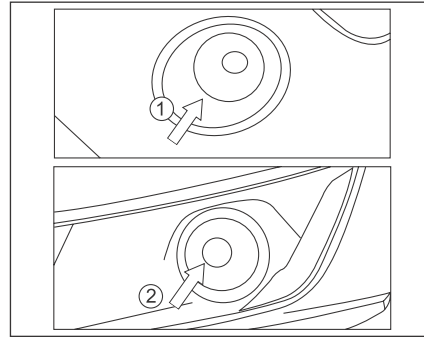

① H30 CROSS front fog lamp (H11/55W)

Remove the fender and pull out the plug, turn the fog lamp bulb base counterclockwise for about 45° to remove it (with the base) for replacement of bulb and its base.

② S30/H30 front fog lamp (H11/55W)

Remove the fender, and turn the dust cover counterclockwise for about 45° to remove the dust cover; pull out the plug, and then press the head of steel clip to decouple it, remove the bulb (with a section of wire) for replacement.

Reinstall in the sequence reverse to that mentioned above. It is recommended to go to either Dongfeng Franchise Store

or IKCO authorised representatives for replacement.

BULB REPLACEMENT

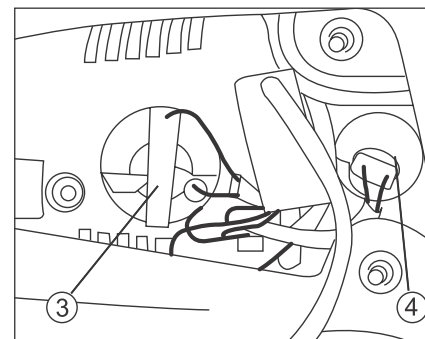
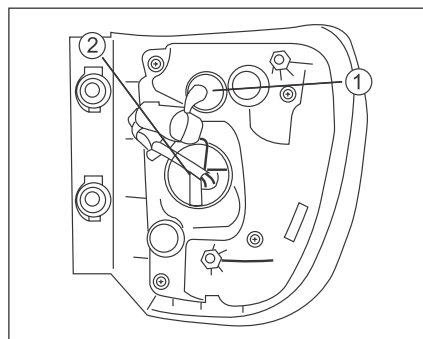
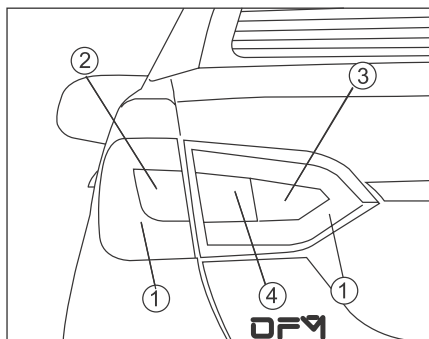

5

Rear combination lamp (S30)

- ① Brake lamp & position lamp: LED
- ② Turn signal lamp: PY21W
- ③ Rear fog lamp: P21W
- ④ Reversing lamp: W16W

Open the trunk lid and two small trim covers of rear combination lamp on rear side wall, and remove two mounting bolts, pull out rear combination lamp backwards, pull out the plug, and remove the rear combination lamp.

① Brake lamp & position lamp (LED)

If brake lamp and position lamp are damaged, have them replaced at Dongfeng Franchise Store or IKCO authorized representatives.

② Rear turn signal lamp (PY21W)

Turn the lamp holder (in orange) counterclockwise for 45° to remove the lamp holder and bulb, press the bulb inward gently and turn it counterclockwise, after removing the bulb for replacement, reinstall it in the reverse order.

Open trunk lid, and remove the interior trim of the trunk lid.

③ Rear fog lamp (P21W)

Turn the lamp holder (in orange) counterclockwise for 45° to remove the lamp holder and bulb, press the bulb inward gently and turn it counterclockwise, after removing the bulb for replacement, reinstall it in the reverse order.

④ Reversing lamp (W16W)

Turn the lamp holder (in white) counterclockwise for 45° to remove the lamp holder and bulb, pull out directly to remove the bulb. After replacing the bulb, reinstall it in the reverse order.

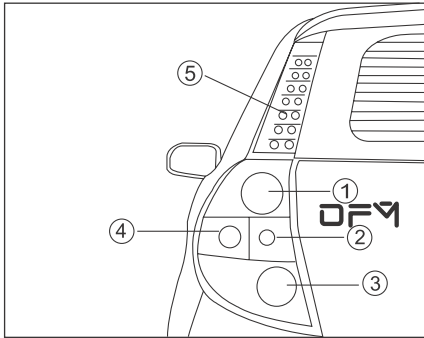

Rear combination lamp (H30)

- ① Brake lamp & position lamp: P21/5W
- ② Reversing lamp: P21W
- ③ Rear fog lamp: P21W
- ④ Turn signal lamp: PY21W
- ⑤ Additional brake lamp & position lamp: LED

Open the liftgate and two small trim covers inside of rear combination lamp, remove two mounting bolts; pull out the plug, and then remove the rear combination lamp.

① Brake lamp & position lamp (P21/5W)

Turn the lamp holder counterclockwise for 45° to remove the lamp holder and bulb, press the bulb inward gently and

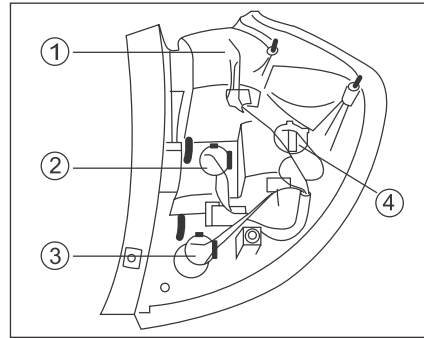

turn it counterclockwise, after removing the bulb for replacement, reinstall it in the reverse order. (Note: Insert the high and low pins on both sides of lamp end correspondingly into deep and shallow notches of the lamp holder)

② Reversing lamp (P21W)

Turn the lamp holder counterclockwise for 45° to remove the lamp holder and bulb, press the bulb inward gently and turn it counterclockwise for removal. After replacing the bulb, reinstall it in the reverse order.

③ Rear fog lamp (P21W)

Turn the lamp holder counterclockwise for 45° to remove the lamp holder and bulb, press the bulb inward gently and

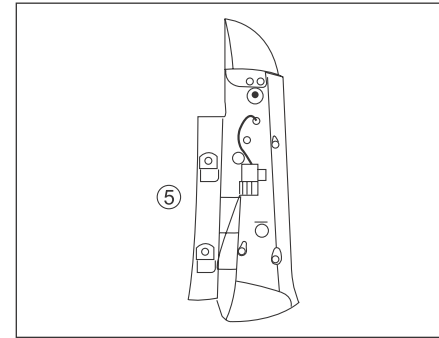

turn it counterclockwise for removal. After replacing the bulb, reinstall it in the reverse order.

④ Rear turn signal lamp (PY21W)

Turn the lamp holder counterclockwise for 45° to remove the lamp holder and bulb, press the bulb inward gently and turn it counterclockwise for removal. After replacing the bulb, reinstall it in the reverse order.

⑤ Additional brake lamp & position lamp (LED)

It is recommended to have the additional position lamp and brake lamp assembly replaced at Dongfeng Franchise Store or IKCO authorized representatives.

BULB REPLACEMENT

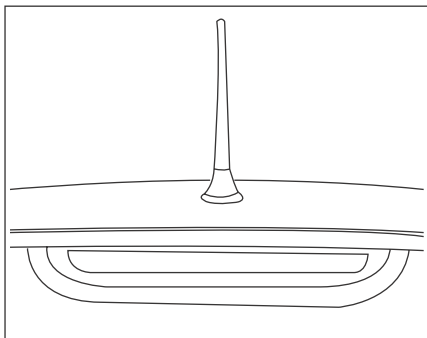

5

High-mounted brake lamp (exterior)

High-mounted brake lamp bulb of S30 should be replaced as per the methods described later.

It is recommended to have the H30/H30 CROSS high-mounted brake lamps (LED) replaced at Dongfeng Franchise Store or IKCO authorized representatives.

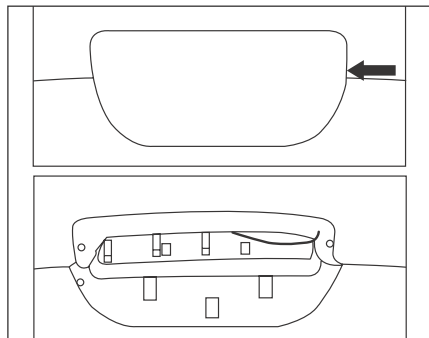

High-mounted brake lamp

(S30/interior) (W5W)

Press the clips at both ends to pull outwards, and remove the housing.

Unscrew the mounting nuts and pull out the plug, remove high-mounted brake lamp assembly and dismantle the lamp holder plate to replace the bulb. Reinstall it in the reverse order.

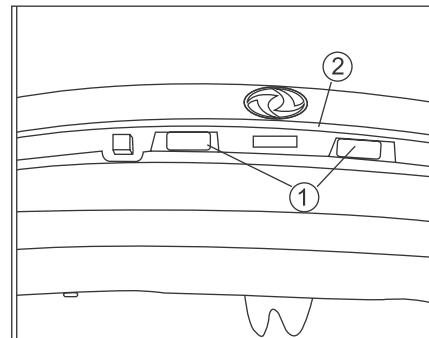

License plate lamp ① (W5W)

Open the trunk and remove its interior trim, remove 4 nuts for mounting decorative strip in the trunk lid and then the decorative strip ② of the trunk lid, lift the lampshade gently from one end of the lampshade with a slotted screwdriver, and then remove the bulb for replacement.

After replacing, reinstall it in the reverse order.

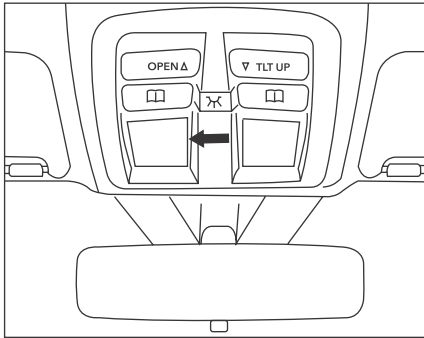

Interior lamp

Lift the lampshade gently from the middle notch on one side of the lampshade with a slotted screwdriver to remove the bulb.

Bulb types

Front roof lamp: 5W, bulb length: 42mm;
Rear roof lamp: C5W, bulb length: 38mm.

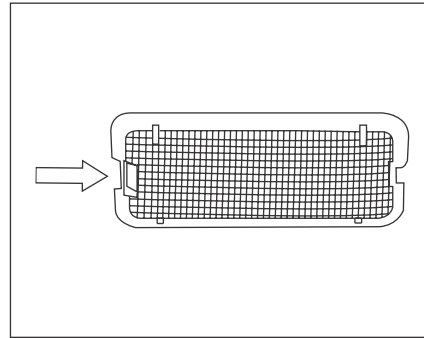

Trunk lamp

Press and hold one end with elastic snap inward to release it, and pick it outwards gently with a slotted screwdriver, remove the lamp assembly to replace the bulb.
Bulb type: C5W, bulb length: 38mm.

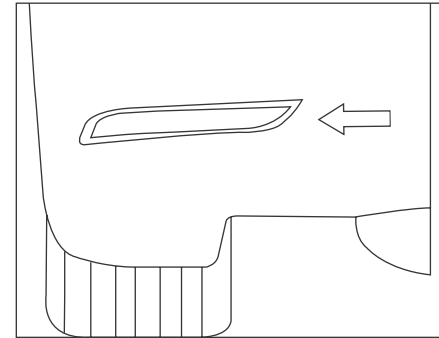

Retro-reflector

The retro-reflector at the vehicle rear is used for reflecting the light from the followed vehicle to remind the driver behind to keep a safe distance.

If the retro-reflector is damaged, it is recommended to have it replaced at Dongfeng Franchise Store or IKCO authorized representatives.

TOWING

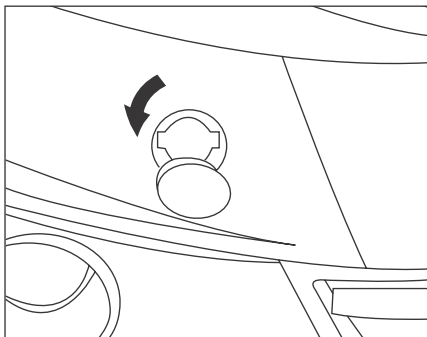

5

Parallel towing (with four wheels of the towed vehicle left on the ground) Towing eye is provided at the front and rear of the vehicle.

The parallel towing at a low speed within a short distance can be performed if allowed by the relevant regulations. Turn the ignition key of the towed vehicle to position A during the towing to unlock the direction lock.

Hook a metal bar onto the towing eye as shown in the diagram above.



WARNING

When the engine is shut off, the power steering and brake booster will not function any more.

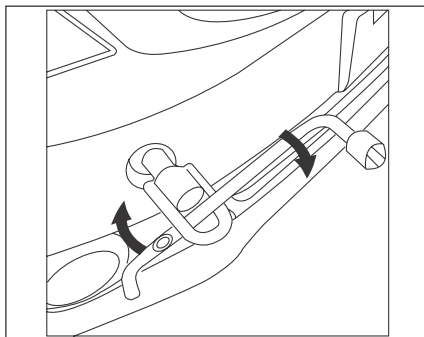

Towing when the front or rear of the vehicle is lifted

Use the special towing device made of rigid rod and connecting strap.

Fix the hook of the special towing device onto each suspension arm.

Take all necessary measures to protect the front and rear bumpers and body sheet metal from damage.



Note:

In case of front towing, pry up the small round cover of the front bumper firstly, and then screw the towing eye, insert tyre wrench into the towing eye to tighten the towing eye completely.

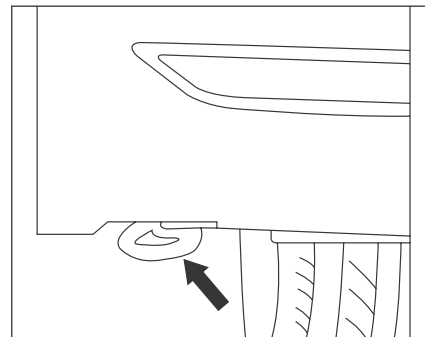

Note:

When the vehicle equipped with the automatic transmission is towed, if the front wheels are on the ground, the gear lever should be shifted to Neutral (N) position.

Because the front wheels will be locked if the gear lever is at P and the P locking mechanism of automatic transmission will be damaged when performing the towing forcibly as a result. The towing speed should be less than 50km/h, and the distance should be less than 50km. Otherwise, perform towing with the lifted front wheels.

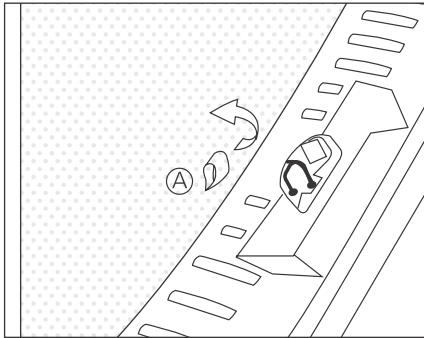

Spare tyre

There is a buckle (A) on the carpet below the trunk lock. Pull the buckle upwards to turn over the carpet.

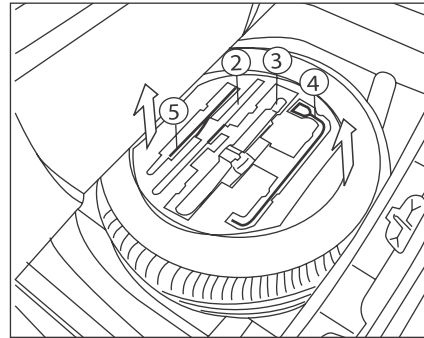

The driver's tools of S30 model is placed in the spacer of spare tyre. Remove the tool spacer to expose the spare wheel.

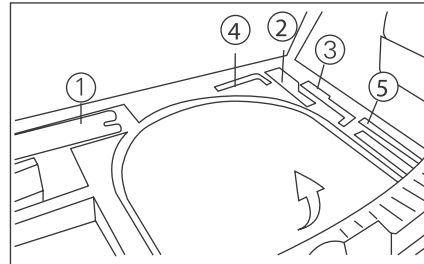

The driver's tools of H30 and H30 CROSS models are placed in the neck of trunk bottom plate. Remove the spare tyre cover to expose the spare tyre.

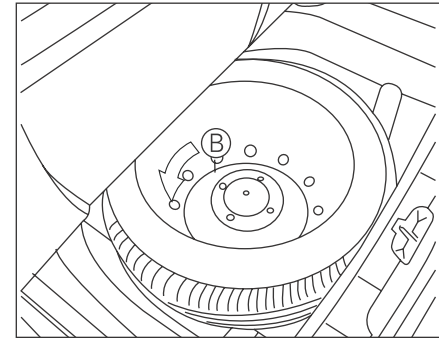

Spare tyre

Turn counterclockwise and remove the spare tyre locking bolt (B) to take off the spare tyre.

WHEEL REPLACEMENT

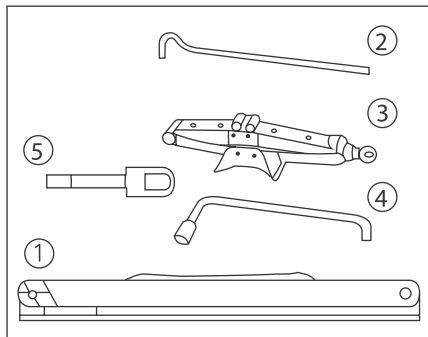

5

Driver's tool

- ① Warning triangle
- ② Jack handle
- ③ Jack
- ④ Wheel wrench
- ⑤ Removable towing eye

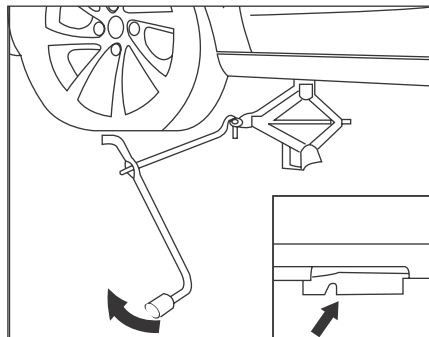

Remove the wheel

1. Park the vehicle on the level hard ground stably; hold the parking brake firmly to stop the engine, and shift the brake to 1st gear or reverse gear (or shift the automatic transmission to P), turn on the hazard warning lamp and ask all passengers to get off the vehicle. Place a cushion block behind the wheel diagonally opposite to the wheel which is required to be replaced;
2. Remove the spare tyre;
3. Take out the jack from the trunk, and place it near the wheel which is required to be replaced, with the jack head groove aligned with the lifting point, lift the jack by a wheel wrench in combination with

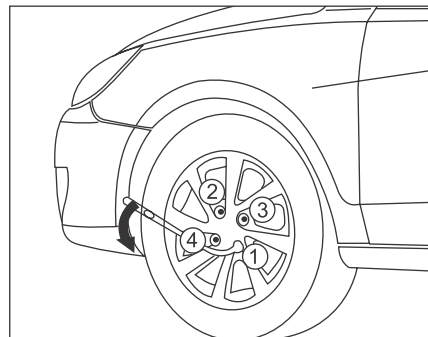

- the jack handle until the jack is loaded, but the wheel should not be off the ground;
4. Loosen the 4 wheel bolts with the wheel wrench diagonally but not fully unscrew them;
5. Lift the jack again until the wheel is off the ground for several centimeters;
6. Unscrew the wheel bolts to replace the wheel.



Note:

Jack is specially designed for the vehicle wheel and cannot be used for other purposes.

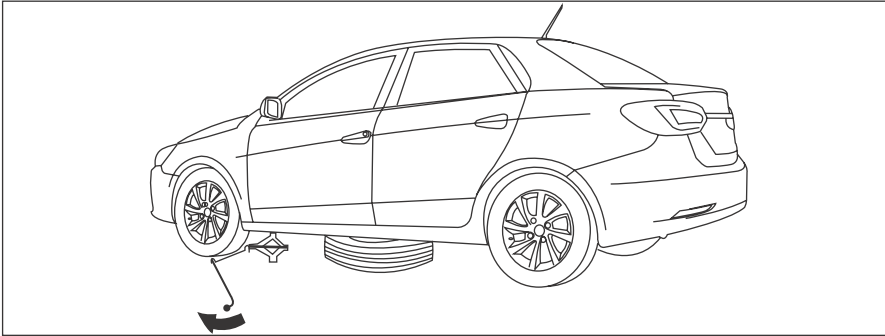

Fit the wheel

Fit the spare tyre onto the hub, and verify that the fitting position is correct. Screw and slightly tighten the bolts. Loosen the jack to make wheel seat on the ground, and take out the jack. Tighten the wheel bolts with wheel wrench diagonally. Inflate the wheel enough, and check whether its pressure is the same with that of the other wheels.

Put back the wheel

Remove the wheel central trim cover from inside, and put the removed wheel into the trunk spare wheel rack, tighten the locking bolts of spare tyre. Put back the wheel wrench and tool spacer.

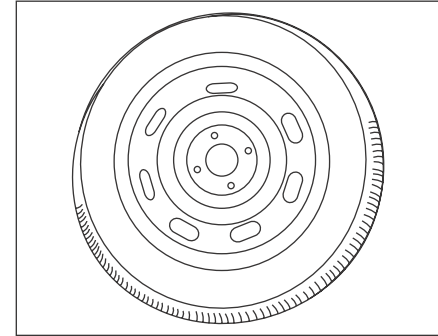

Steel rim spare tyre

If your vehicle is equipped with light alloy wheel or steel rim spare tyre and it is replaced with a steel rim one, drive the vehicle with a speed not more than 80km/h to the nearest Dongfeng Franchise Store or IKCO authorized representatives for repair, after the wheel acceptable for normal running is repaired properly, replace the spare tyre immediately.

5



WARNING

When the vehicle is lifted by the jack only, do not have any part of your body stretched under the vehicle.

TYRE

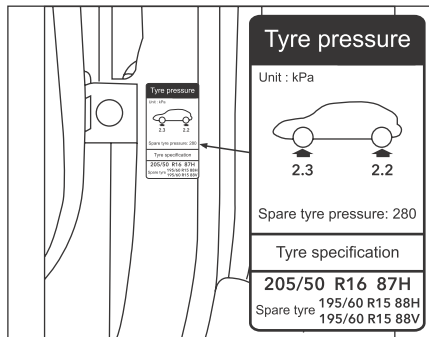
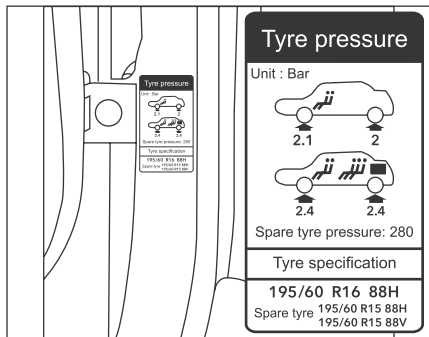

5

Tyre inflation pressure

For tyre inflation pressure, please refer to the tyre pressure label on the front lower side of left front door frame.

E.g.: (Unit: kPa)

Tyre spec.	195/60 R15 88H/V		205/50 R16 87H
Front tyre pressure	210±5 (Light load)	240±5 (Heavy duty)	230±5
Rear tyre pressure	200±5 (Light load)	240±5 (Heavy duty)	230±5
Spare tyre spec.	195/60 R15 88H/V		
Spare tyre pressure	280		

Tips:

To ensure safety driving, it is very important to always keep tyres in good condition.

Note that the tyre inflation pressure should always meet our recommendations and should be checked regularly (for example once per week). Before long driving, perform systematic checks, and do not forget to check spare tyres! The tyre should be checked in cold, for the tyre will be heated during driving to increase the tyre pressure. Do not correct the tyre pressure when the tyre is hot.



WARNING

Insufficient inflation will cause the tyre temperature rise abnormally, thus the tyre may be damaged abnormally, even disposed as a result. Excessive inflation, on the other hand, will cause tyre swell and suspension system damage.

The insufficient inflation pressure leads to a high probability of flat tyre when driving on the expressway.

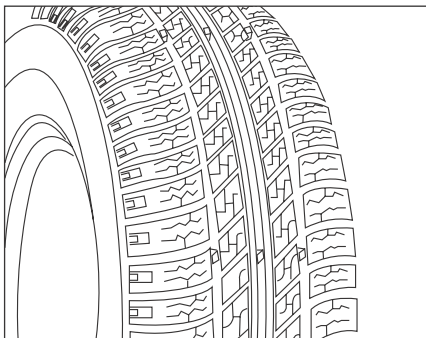

Bouncing on the road pits, colliding with the unexpected obstacles and driving in poor road conditions frequently are important causes of tyre damage and thus should be avoided when driving. Check the tyre for such damage regularly as abnormal wears, cuts, cracks, swell etc.

Clear all foreign inserts (stones, metal pieces etc.) which may penetrate the tyre, for they may damage the tyre seriously, if you have doubts about the tyre, have it checked at Dongfeng Franchise Store or IKCO authorized representatives.

Do not fit the tyre to whose previous utilization you have no idea without



consent of specific personnel. Even the tyre not being used or just being used occasionally may age. The cracks of rubber on tyre tread and sides indicate signs of aging, accompanied by the tyre deformation usually. Therefore, your old tyre should be checked by an expert in order to determine whether it can be resumed. In a nutshell, all tyres fitted on the vehicle should be checked regularly anyway, especially the spare tyre. Be cautious to use the old tyre, having it checked frequently and replaced immediately in case of abnormalities.

Check the tyre tread for wear regularly, for the tyre adhesion properties will be weakened with the aggravation of wear, the tread wear mark indicates the tyre use limit, Replace the tyre immediately when the wear limit is targeted.

Be cautious when driving on the wet road.

Once a flat tyre occurs, stop the vehicle safely as soon as possible for tyre replacement, because driving with a flat tyre will damage the tyre.

The tyre repair, removal and refitting must be performed by the professional personnel with a tyre changer to avoid damage of the tyre and wheel rim. Do not change the tyre directly with hands. After the tyre is repaired, perform inspection and correction to the tyre dynamic balance.

Otherwise, the vehicle will shake violently when driving at high speed and the tyre will be worn abnormally.

For your safety, please use the tyres recommended by us only.

5

**WARNING**

When replacing the tyre, do not use the tyre in different brands, types, treads or with large condition differences on the same axle (except for the spare tyre used temporarily in emergency).

SAFETY TIPS

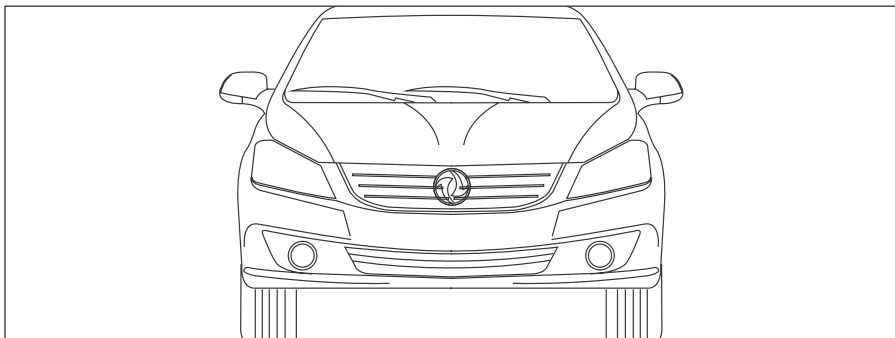

5

Tips

To ensure a pleasant, comfortable and safe journey, please note the followings: In rainy and chilly days In rainy or foggy days, slow down the driving, keep an appropriate distance from the vehicle in front (braking distance is increased due to the slippery road), and turn on low beam and fog lamp.

On wet road, especially when the tyre tread height is less than 3mm, the tyre adhesion will be decreased, when there is stagnant water on road, slippage may occur even the tyre is in good condition. Replace the wiper once it fails to wipe off the water on the window.



Note:

The engine will be stopped when wading, in the case, do not restart the engine forcibly but seek help from Dongfeng Franchise Store or IKCO authorized representatives.

Take special care when the ambient temperature is 0°C or lower. In winter, it is recommended to use snow tyre and drive gently without sudden acceleration or braking.

On road with potholes & stagnant water

Potholed road will cause damage to the tyre, wheel rim, chassis or driving system. When driving on road with stagnant water, some water may seep into the engine to cause irreversible damage to the engine. If water swells suddenly and up to the underbody, do not drive it any more but park it at a safe place.

Lighting

Always ensure a good visibility.

A set of spare bulb, a flashlight and a pair of sunglasses shall be reserved on the vehicle.

For the safety of yourself and others, the lighting devices must be in good condition and should be adjusted properly and kept clean.

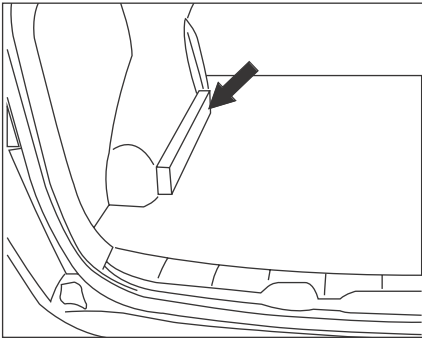

Warning triangle (accessory)

When the vehicle cannot be driven off the lane or is stopped on road shoulder because of failures, accidents etc., it is a must to turn on hazard warning lamp and set warning triangle in the back of the driving direction to remind of the vehicles behind.

Warning triangle of S30 model is on the left of the trunk carpet.

Warning triangle of H30 and H30 CROSS models is in the slot of the trunk carpet lower bottom plate (see Page 151).

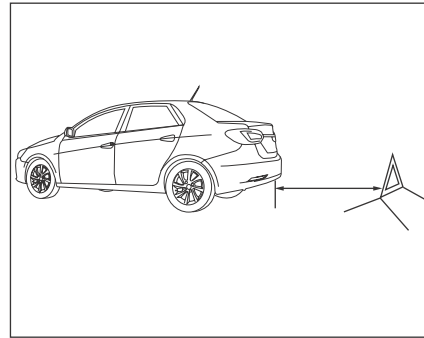

	Ordinary highway	Expressway
Distance	50-100m	≥150m

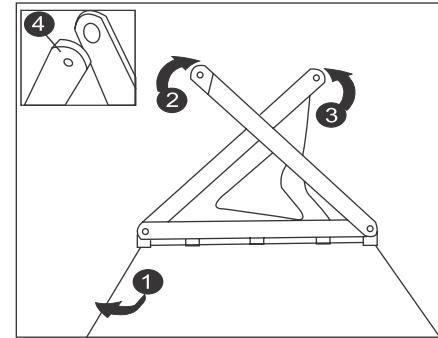

Unfold the warning triangle

Unfold the 4 bottom brackets **1** ;
 Unfold the 2 folded edges **2** and **3** ;
 Fasten the snap **4**, and put the side with reflective materials backwards.
 Fold it in the reverse order and put it away after use.

5



Note:

The values motioned here are for reference only, please place the warning triangle at a distance specified by traffic regulations.

SAFETY TIPS

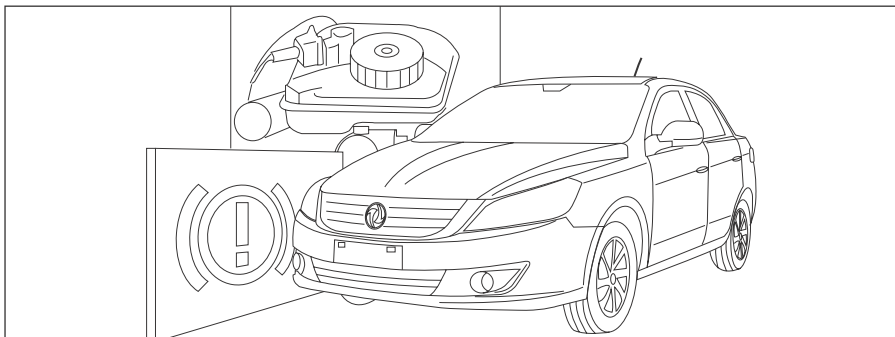

5

Braking

The level of brake fluid should be checked regularly.

If the low brake fluid level warning lamp turns on during driving, stop the vehicle immediately to check, and contact Dongfeng Franchise Store or IKCO authorized representatives if necessary. After washing the vehicle or driving on wet road, the braking response may be slightly slow.

Brake friction plate of the new vehicle or the newly replaced one can achieve the best braking effect only after run-in for a certain mileage.

In order to maintain good braking performance, replace the brake fluid regularly as specified in Warranty Manual, and the brake fluid must be replaced at Dongfeng Franchise Store or IKCO authorized representatives by the professional personnel.

Check before driving each time

Lamps, turn signal lamps and brake lamp;

Rearview mirror position;

Brake system performance;

Cleanliness of glass various lamps and glass windows.

Regular check

Tyre conditions and pressure;

Level of various fluids;

Working conditions of wiper blade.

6 TECHNICAL CHARACTERISTICS

General technical characteristics	156
Outline dimensions	157
Vehicle identification.....	159

GENERAL TECHNICAL CHARACTERISTICS

Model code	S30	H30	H30 CROSS	S30	H30	H30 CROSS	
Model	DFM7160B1E	DFM7160B2E	DFM7160B3C	DFM7160B1D	DFM7160B2D	DFM7160B3B	
Engine model	N6A10FX3A PSA						
Engine type	Inline 4-cylinder, DOHC, 16 valve, MPFI, electronic throttle						
Engine displacement cm ³	1587						
Engine max. net power kW/rpm	77/5750						
Engine max. torque: Nm/rpm	142/4000						
Transmission	MA5 mechanical reinforced 5-speed MT			AISIN Step-Gate 4-speed AT			
Tyre spec.	195/60 R15	195/60 R15	205/50 R16	195/60 R15	205/50 R16	205/50 R16	
Trunk volume L	487	417/1137	417/1137	487	417/1137	417/1137	
Effective volume of fuel tank L	51						
Fuel	RON93 or above unleaded gasoline, compatible with E10 ethanol gasoline (Note)				3 (Note)		
Fuel consumption every 100km, L/100km	60 km/h	4.6	4.7	4.7	4.9	5	5
	90 km/h	5.7	5.8	5.8	6.0	6.1	6.1
Min. turning radius m	5.26						
Max. speed km/h	187	183	183	180	171	171	
Front suspension	McPherson independent suspension						
Rear suspension	Double-torsion bar and longitudinal-arm independent suspension with stabilizer bar						
Brake system	ABS dual-circuit hydraulic brake system, with front brake being of vented disc and rear brake of solid disc						
Steering system	Rack and pinion hydraulic power steering						
Curb weight kg	1210	1206	1230	1240	1230	1254	
Max. allowable curb weight kg	1575	1581	1625	1615	1605	1649	

OUTLINE DIMENSIONS (S30)

Dimensions in mm

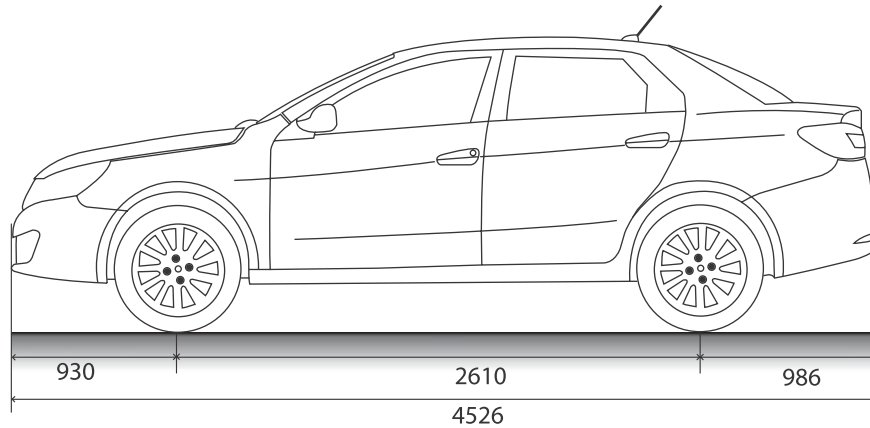
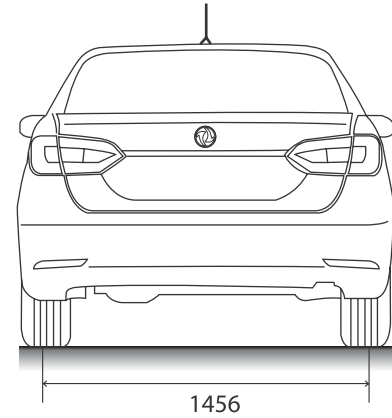
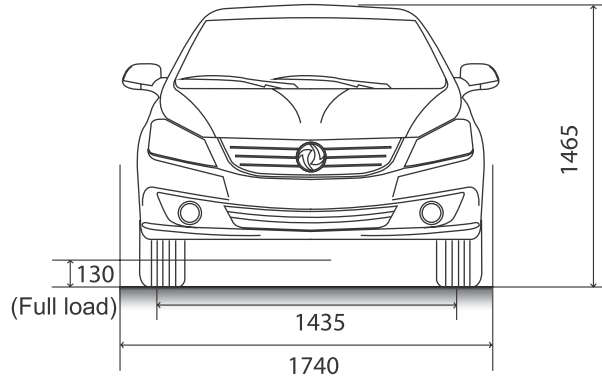

OUTLINE DIMENSIONS (H30 CROSS)

Dimensions in mm

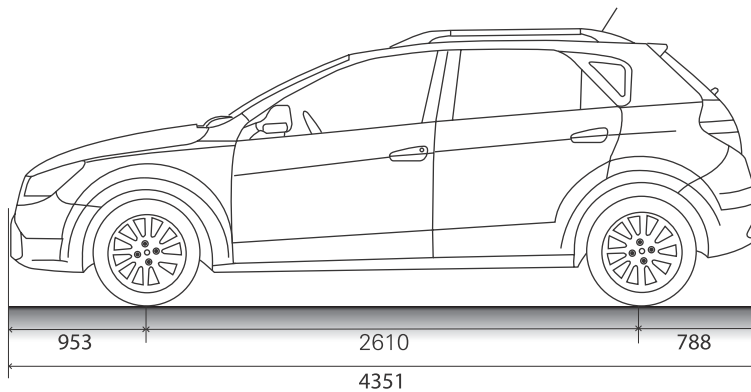
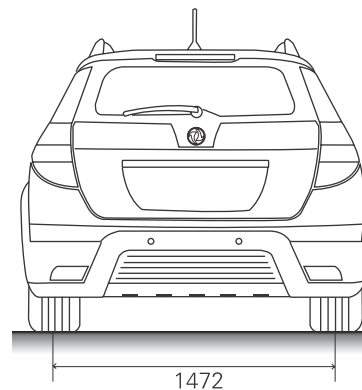
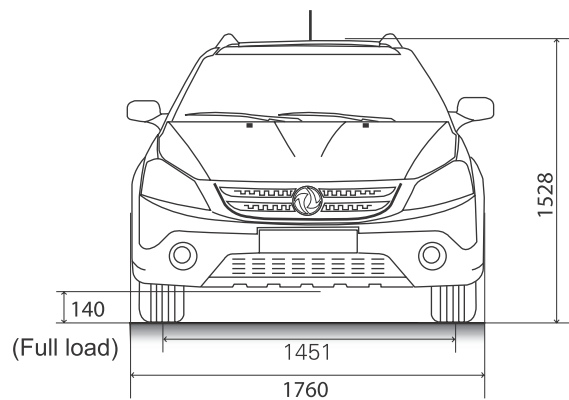

6

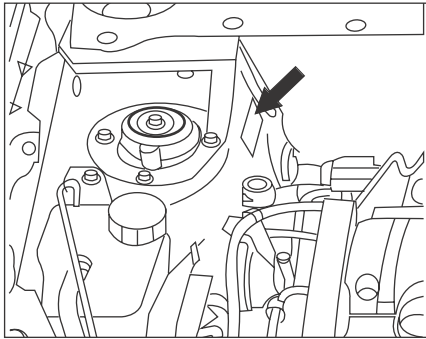

Product label

It is in the right of engine compartment.

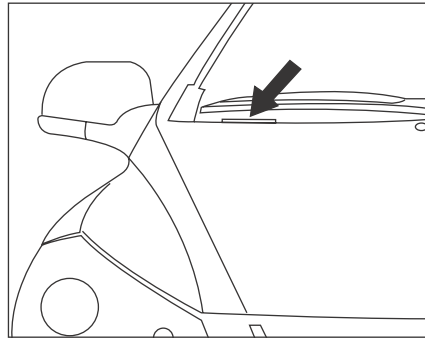

VIN plate

It is in the right lower part of front windshield.

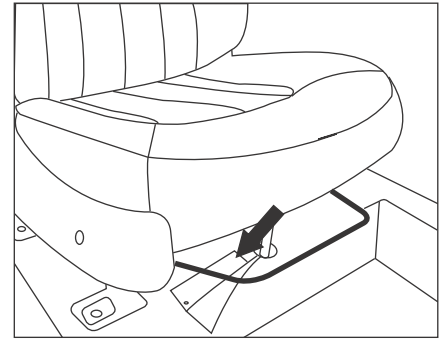

VIN printing position

VIN is printed on the front cross member of right front seat in cabin, and it is visible once the seat is moved to the rearmost position and the access hole in carpet is opened.

For other complete vehicle labels and component labels, see left front door, right rear door, left B-pillar, right B-pillar, right trunk hinge and transmission.

 **Manufactured by Dongfeng Motor Corporation**

VIN:

Brand: Dongfeng Model:

Max. permissible total mass **kg** Capacity:

Engine model:

Engine displacement: **ml** Max. net power: **KW**

Manufacturing date: Made in china

VEHICLE IDENTIFICATION

Identification positions

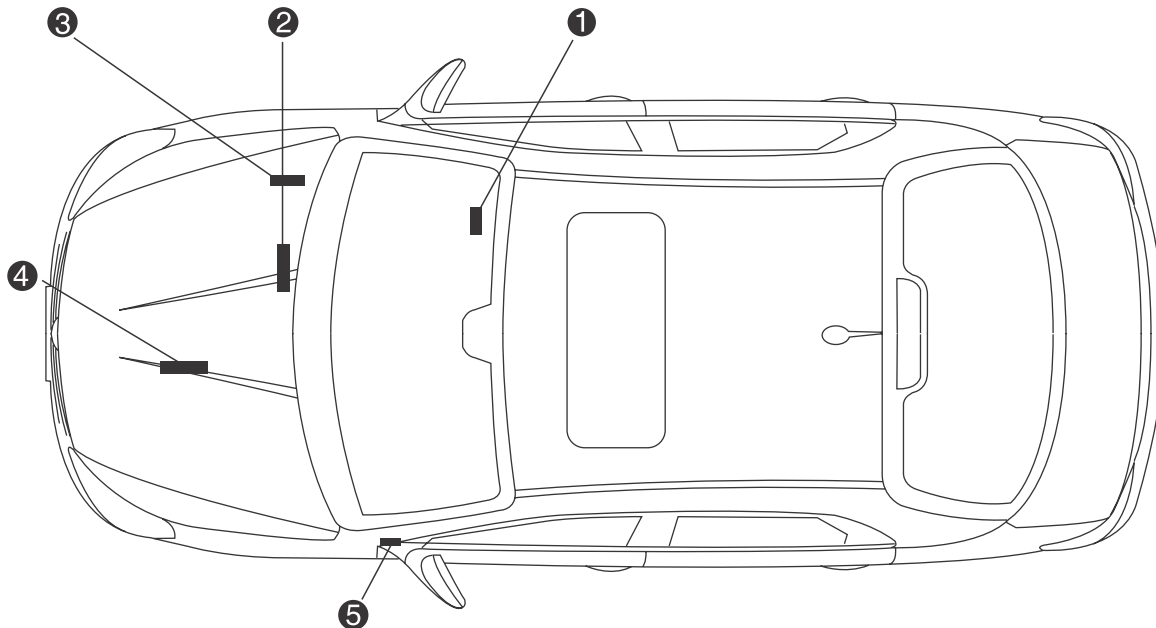

6

① VIN

② VIN plate

③ Product label

④ Engine No.

⑤ Tyre pressure label (at lower part of left front door frame)

7 INDEX

INDEX

A		D		Interior Equipment	59 & 60
Adjusting Safety Belts	48	Demisting	107	Introducing CNG Fueling System	
Adjusting The Steering Wheel	79	Digital instrument Panel	99	Placed In Trunk Lid	112
Air Bag	35	Dimensions	22	L	
Air Pressure Of The Tires	131	Disconnection Of Battery	138	Locking & Unlocking of The Doors	20
Anti Pinch System	115	Driving & Environment	24	Locking/Unlocking of the Engine Cover	
Anti Theft Security System (Immobilizer)	19	E		Door	22
Anti-Lock braking System(ABS)	97	Electric Side Glass Lifter	58	M	
B		Engine Compartment	121	Maintenance Of The Car	127
Battery Care & Maintenance	137	F		Maintenance Of The Vehicle's natural	
Battery Safety Tips	152	Folding Exterior Mirror (electrical)	86	leather	126
Battery To Battery Connection	138	Front Ash Tray	111	Manual Brake	98
Brake System	97	Fuel Filler Flap	23	Manual Gear Box	90
C		Fuses	133	Mirrors	86
Changing The Battery	137	G		O	
Changing The Lamps	145	Glass Cleaner & Windshield Wipers	83	Opening the Fuel Filler Flap In	
Changing The Wheels	149	H		Emergency situation	23
Charging Battery	65	Heating / Ventilation	60	Overview	4
Checking The Coolant	63	Hydraulic Steering Wheel	79	P	
Checking The Motor Oil Level	123	I		Pollution Control system	131
Clock	73	Ignition Switch	59,60 & 67	Puncture	149
CNG Parts	112	Intelligent Windscreen switches	58		
Child Safety	53				

R

remote control	16 & 17
Rear Ash Tray	111
Rear shelf	122
Recommendations For Washing The Vehicle	127
Releasing Of The Lock For Steering Wheel	79

S

Safety Of The Road	93
Safety Of The Vehicle	39
Saving In Fuel Consumption	131
Seat Belts Safety Tips	48
Seats	27
Starting and Driving	90-95

T

Technical Information of The Engine	156
Transporting The Vehicle	146
Tread wear Indicator	151

V

VIN plate	159
Vehicle Transport	146
Vehicle Identification	159-160

W

Warning Lamps	84
Winter Precaution	152

Roads await you ...



IRAN KHODRO Company (Public Joint Stock)

Gate No. 1, Iran Khodro Blvd,
KM.14 Karaj Makhsous Rd,
Shahid Lashgari Highway, Tehran, IRAN
Postal Code : 1389913657
Tel: (+9821) 48901
Fax: (+9821) 44934000-1
SMS Centre: (+98)30003
E-mail: info@ikco.ir
www.ikco.ir