

PEUGEOT PARS

PEUGEOT PARS
PEUGEOT PARS ELX
PEUGEOT PARS BI - FUEL
PEUGEOT PARS AUTOMATIC

Owner's Manual

This manual has been prepared to inform you of how to optimize the use of the vehicle and contains important notes on safety, operation and maintenance. Please keep this manual in your car at all times and be diligent in maintaining it.



In The Name of God



OWNER'S MANUAL
PARS

DEAR BUYER

We're thankful for choosing Iran Khodro product and we congratulate you for this good selection. We hope this new vehicle contributes in happy moments of your life.

This manual helps you enjoy driving. Therefore to have an easy access, it would be advisable to be kept in your glove compartment. The manual is divided into some sections for your convenience, and deals with various aspects of driving or maintenance of the car.

Before driving: Includes seat adjustment, Safety belts, heating and ventilation control system and also every other thing you needed to know in order to settle comfortably.

Driving Controls: explain functions of switches, equipment and precautions.

Maintenance: Includes information about the checks you should carry out regularly.

Note:

Please refer to maintenance and guaranty services manual to know about the vehicle maintenance, regulation & condition of guaranty services and periodic services.

Technical emergencies: Help solve some of unavoidable small emergencies occurring occasionally like replacing lamps fuses or changing wheels.

Technical data: It includes some information about engine, dimensions, capacities and weights.

WARNING, CAUTION and NOTE have special meanings. These special meanings apply except when laws or regulations require that the signal words be used with a different meaning. Pay special attention to the messages highlighted by these signal words:

In the meanwhile consumptive material must be provided through authenticated representatives of IKCO.



WARNING: Indicates a potential hazard that could result in death or injury.



CAUTION: Indicates a potential hazard that could result in vehicle damage.

NOTE: Indicates a serious damage to your vehicle in the case of not paying attention to the warning and caution signals.

Important Point: The specification of each vehicle will vary according to its type. Therefore some information of this manual may not be true about your vehicle. For any more information, you can consult with IRAN KHODRO dealers.

Reminder: Information about other varieties of this product have been mentioned in this manual and denoted by asterisk (*).

PEUGEOT PARS AT A GLANCE 1

BEFORE DRIVING 2

DRIVING 3

MAINTENANCE 4

TECHNICAL EMERGENCIES 5

TECHNICAL DATA 6

INDEX 7

OVERVIEW

LOCKING / UNLOCKING DOORS	24
CHILD SAFETY	38
LAMPS / DISPLAYMENTS.....	44
WINDSHIELD WIPER AND WINDSHIELD WASHER	46
AUDIO SYSTEM	50
HEATING / VENTILATION	61
AUTOMATIC AIR CONDITIONING	65
INTERIOR EQUIPMENT.....	72
AIRBAG	73
DIGITAL DISPLAY PANEL	85
STARTING AND DRIVING	86
ENGINE COMPARTMENT	98
BRAKES	102
BATTERY.....	104
TECHNICAL EMERGENCIES (CHANGING WHEELS, TOWING, CHANGING FUSES, CHANGING LAMPS)	109
MAINTENANCE, SERVICE AND CHARGE OF THE BATTERY	131
TECHNICAL DATA	137

*If equipped

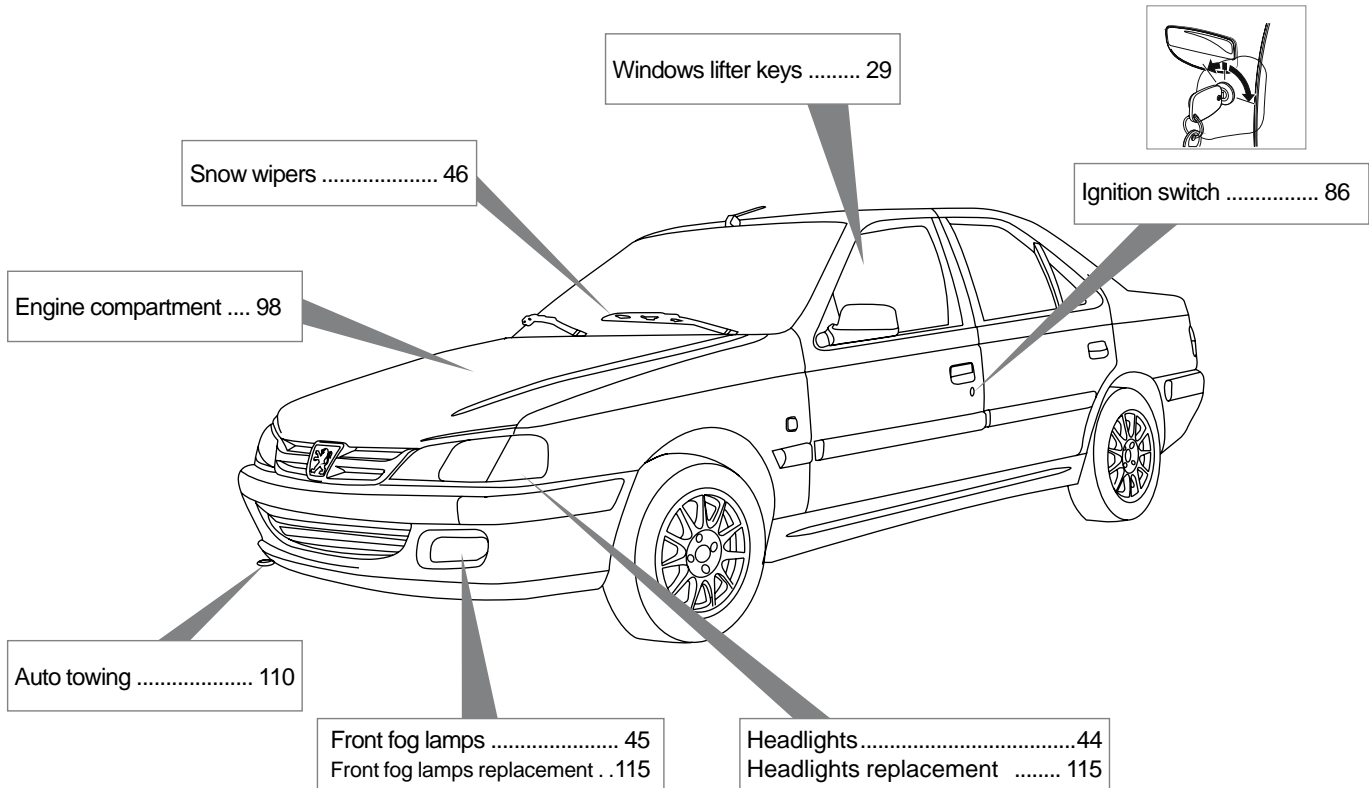

PICTORIAL LIST

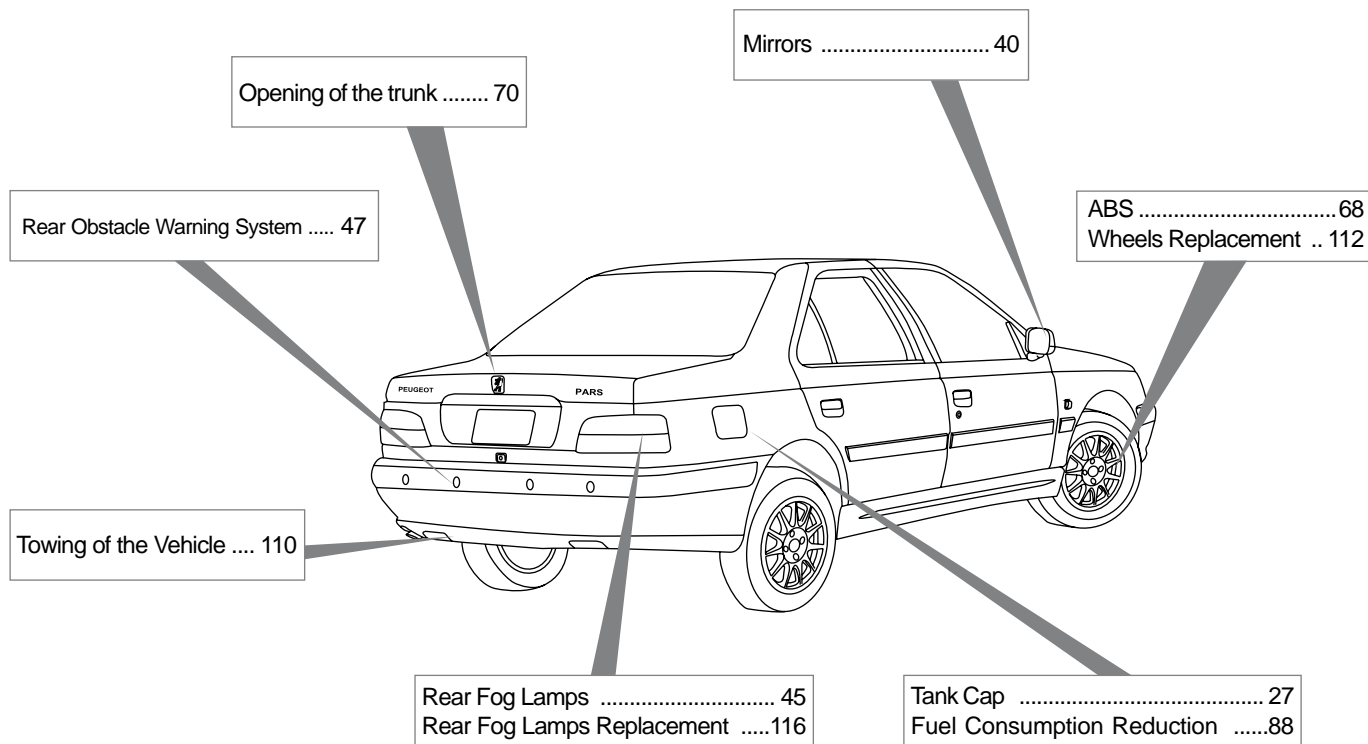

Engine Compartment

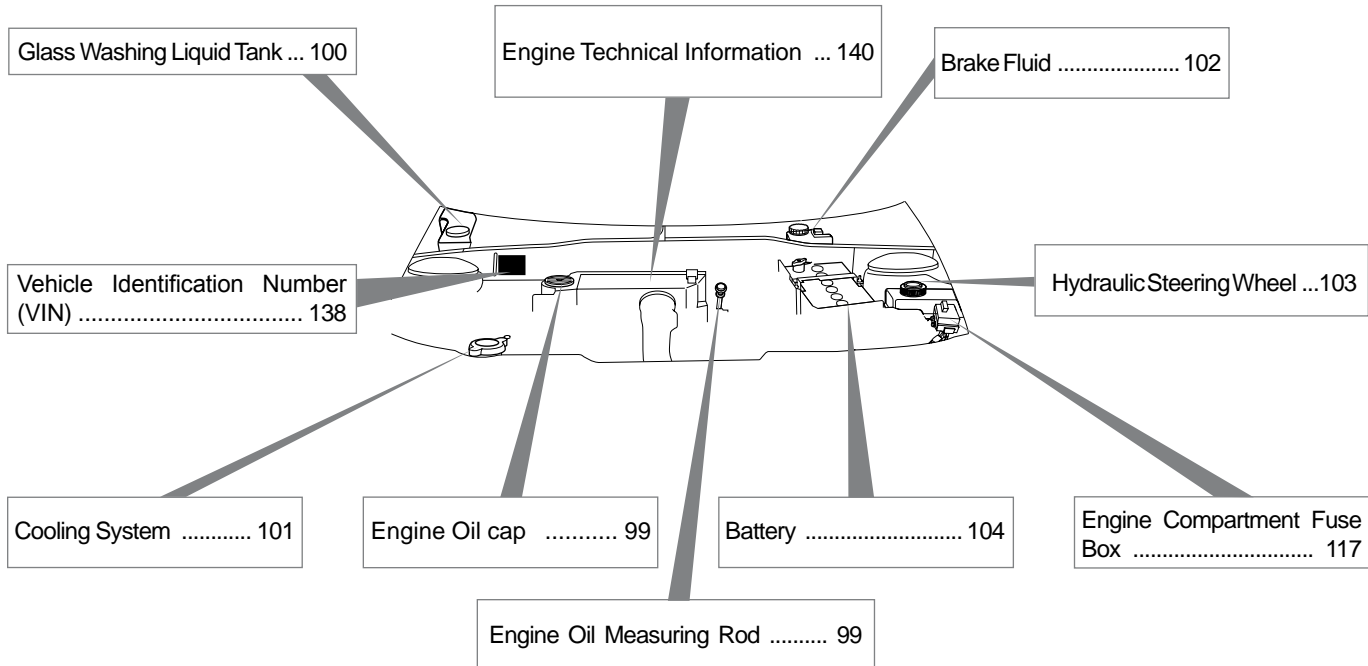

PICTORIAL LIST

Engine Compartment

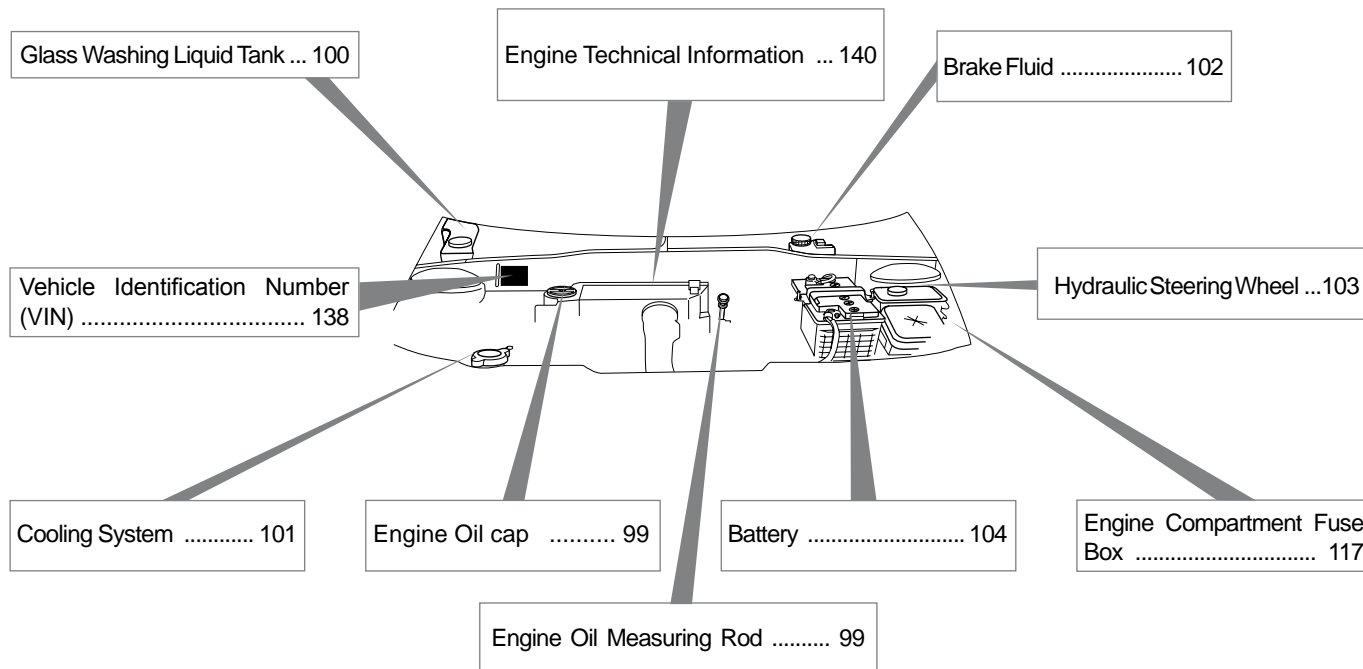

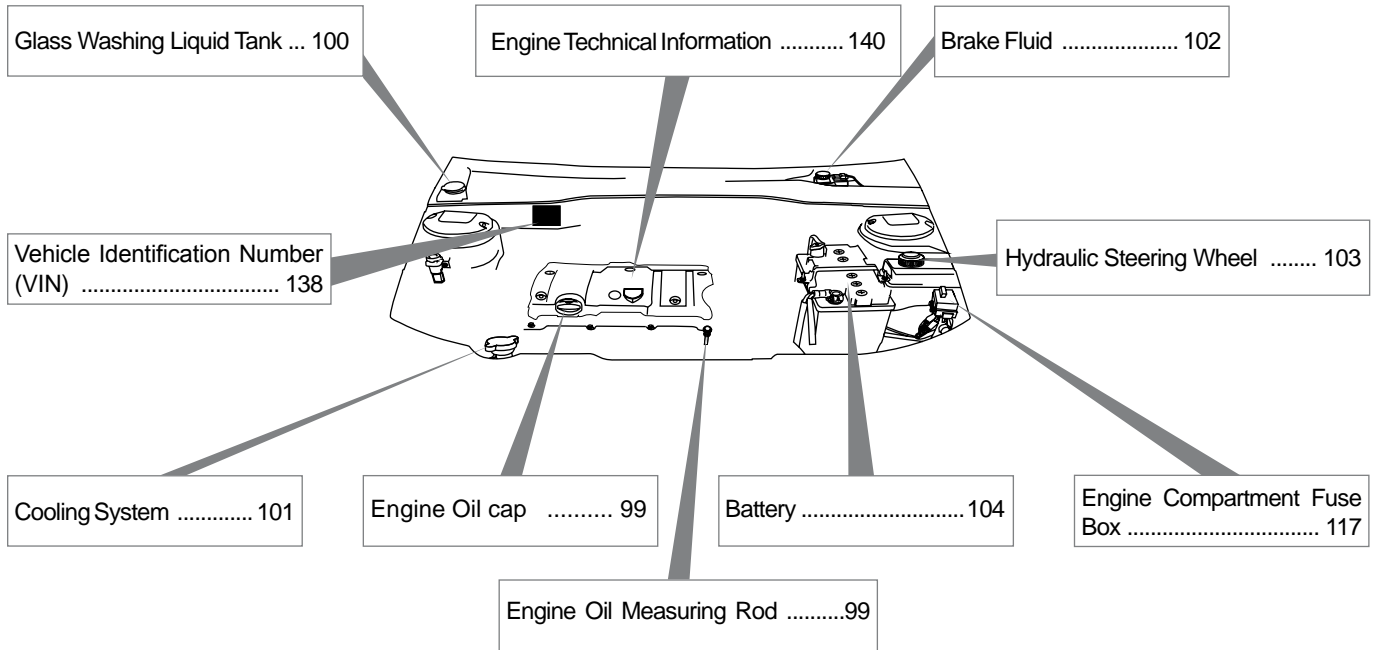

*If equipped

1 PARS AT A GLANCE

CONTROLS	10	ELECTRICAL MIRRORS	18
LOCKING/UNLOCKING DOORS	12	AIR BAG	19
ANT-THEFT SYSTEM (IMMOBILIZER)	13	CHILD SAFETY LOCK	20
INDICATORS AND LIGHTS KEY	14	HANDS FREE CELL PHONE	20
WINDSHIELD WIPER	14	CNG FUEL MODE (STARTING/DRIVING)*	21
SEATS	15	FUEL TYPE	21
AUTOMATIC AIR CONDITIONING	16	Audio System Control Panel	22
ELECTRIC WINDOW	17		

*If equipped

PARS AT A GLANCE

1

CONTROLS:

- 1- Horn, front light button and side lights lever handle.
- 2- Front dashboard digital monitor.
- 3- Air vents to avoid freezing and sweating of the front glass.
- 4- Middle adjustable air vent for Air condition.
- 5- Sound systems
- 6- Sides adjustable air vent for Air condition.
- 7- Fuse box.
- 8- Handle lever for releasing engine cover door.
- 9- Windscreen wipers and glass cleaners.
- 10- Gear lever (Gear shift).
- 11- Automatic A/C system.
- 12- Ashtray and lighter.
- 13- Dashboard box.
- 14- Driver Air Bag.
- 15- Passenger Air Bag
- 16- Passenger Airbag Deactivation Key

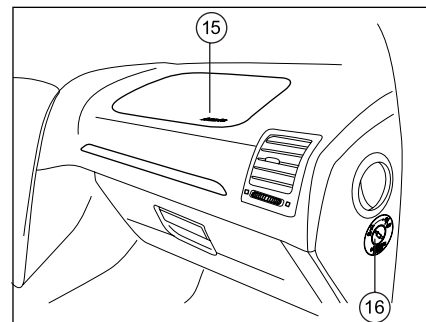
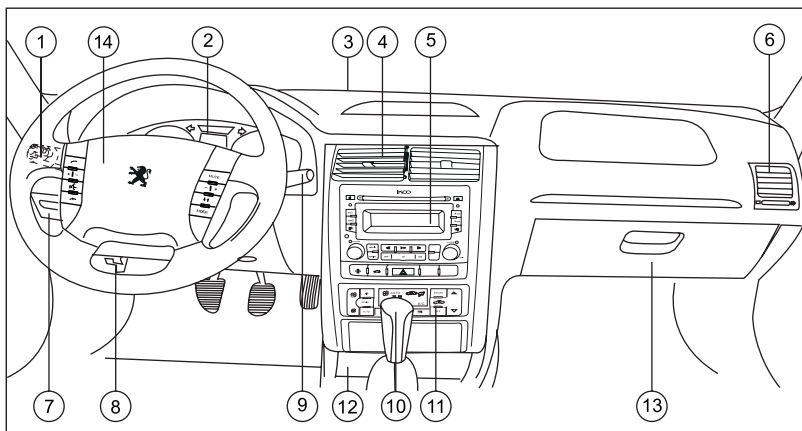

CONTROLS:

- 1-Hands free mobile.*
- 2- Button for transforming types of fuel in bi-fuel vehicles.*
- 3-Opening key for the boot.
- 4-Emergency light button (Flasher).
- 5- Button for Rear glass heater .
- 6- Button for Front glass heater
- 7- Locking Switch for the Rear Lifting Glass.

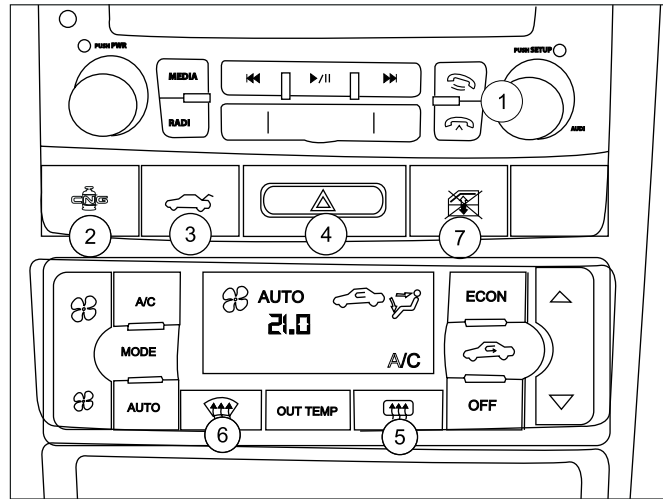

*If equipped

PARS AT A GLANCE

1

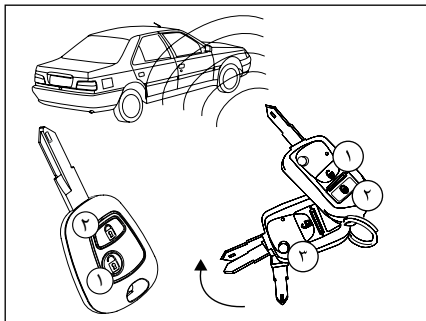

Locking and unlocking of the doors:

Side doors, rear trunk, fuel tank cap cover:

With the use of key:

For opening the door, pull up the external handle.

From inside:

Push down the interior locking button, door will be locked. For opening the lock, pull up the same button and for opening the door, pull the interior handle.

With the use of key (switch) and central locking system:

All doors, rear trunk and fuel tank cap cover, can be opened or closed simultaneously with the help of switch key from outside and the locking buttons on front doors from inside.

Meanwhile, by using the front doors lock button, we can only lock the trunk lid. For opening that, we should use the switch.*

*If equipped

3- With the use of remote control:

The operation of this device is like switch key. To operate the device, hold it towards the direction of the receiver which is situated above the interior mirror and push the button.

- Button 3 (Jack knife*) switch blade will get open clockwise.

locking and unlocking of doors:

Engine cover door:

1-From inside: Pull the interior handle below the dashboard until the lock is released.

2- From outside: pull the safety holder beneath the engine cover door towards yourself until the safety lock is released.

To keep the engine door open, use the leaning rod. To close the engine door, bring down the leaning rod and **leave the door to drop by itself from a distance about 30 centimeters.** Make sure that the door is completely locked.

Fuel Filler Flap

3- To open fuel filler flap, press the frontal flap of tank valve.

WARNING



The fuel inside the tank, might be pressurized. Therefore to avoid fatal damages, do not open the fuel cap rapidly. Slowly and precisely turn to open the cap and wait for a sound of "Hiss" to stop. Then open the cap completely

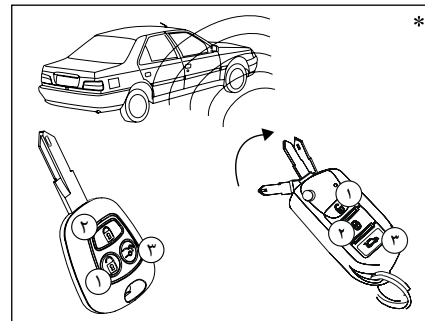

Opening the fuel filler flap in emergency situations

4- If the central locking system does not operate, you can open the flap from inside the trunk.

Lock and unlocking by remote controller*

Keep the remote control towards the vehicle :

key no.1 is for unlocking

key no.2 is for locking

key no.3 is for unlocking of boot

(The boot will get open by two successive pressing or in some models holding the key for 5 seconds).

NOTE

Frequent pressing of the keys in short intervals will cause the keys functioning cessation for 20 seconds.

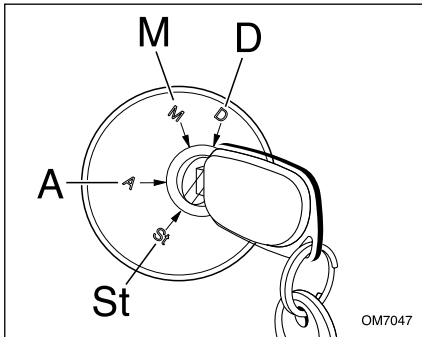

Steering wheel lock

Open the steering wheel lock before starting the engine if it is necessary, turn the steering wheel gently while you are rotating the key.

It is recommended to press the clutch at the time of starting, so that ignition get easier.

Ignition Switch

POSITION St: St is off, switch is closed.

POSITION A: The steering wheel is unlocked. Just electrical accessories and equipment operate.

POSITION M: The switch is open.

POSITION D: Turning on the engine (start)

NOTE
There is possibility of breakage for internal parts of the remote controller in case of sever impact and subsequently not functioning of the immobilizer.

CAUTION 

- Never drive when the engine of your vehicle is cold.
- Never start engine in closed area
- Never do any alterations in steering lock.

WARNING 

Avoid keeping the battery or remote controller in infants' access, because swallowing of the battery can cause death. In case of swallowing the battery, refer to health care centers immediately.

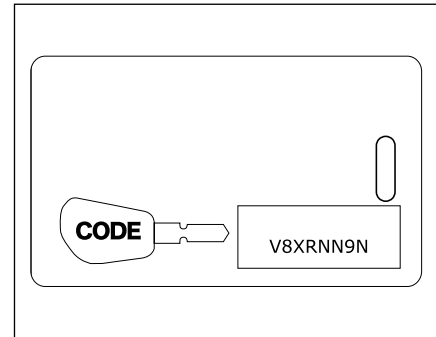

Anti- Theft Security System (Immobilizer)

The vehicle with immobilizer system can only start up with two keys which is delivered to customer with the vehicle.

To copy of key is not enough for start up. It is possible to have more keys if the customer requests and only in IRAN KHODRO dealers with the DIAG tool.

NOTE
A number has been carved on the key plate for replacing the key. Therefore keep the plate in a safe place and never inside the car.

PARS AT A GLANCE

1

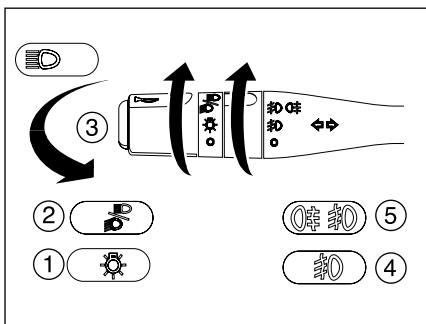

The key buttons for lights, side light lever handle and horn:

- 1-Small, rear lights and digital trip recorder.
- 2- Head light, downward/upward beam.
- 3- Head light, upward beam (pulling the lever toward the driver)
- 4- Front fog lamp
- 5- Front / rear fog lamp

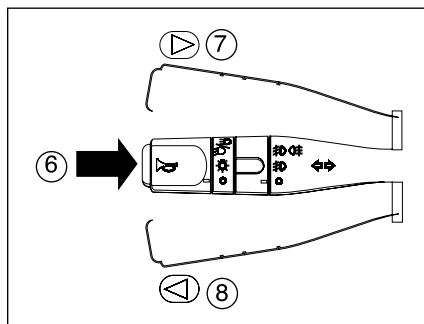

- 6- Horn
- 7- Right side blinker
- 8- Left side blinker

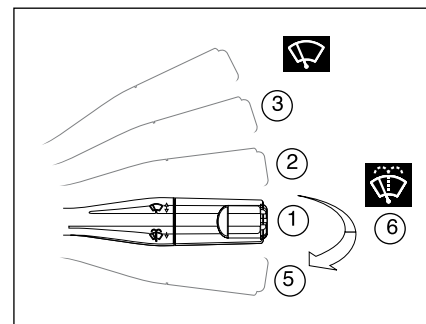

Windscreen Wipers and Glass Cleaners:

- 1- Off
- 2- Time controlled window wipers. (Is adjusted according to the vehicle speed)
- 3- Slow speed window wiper.
- 4- High speed window wiper.
- 5- Intermittent move of the window wiper.
- 6- Glass cleaners. (pulling the lever toward the driver)

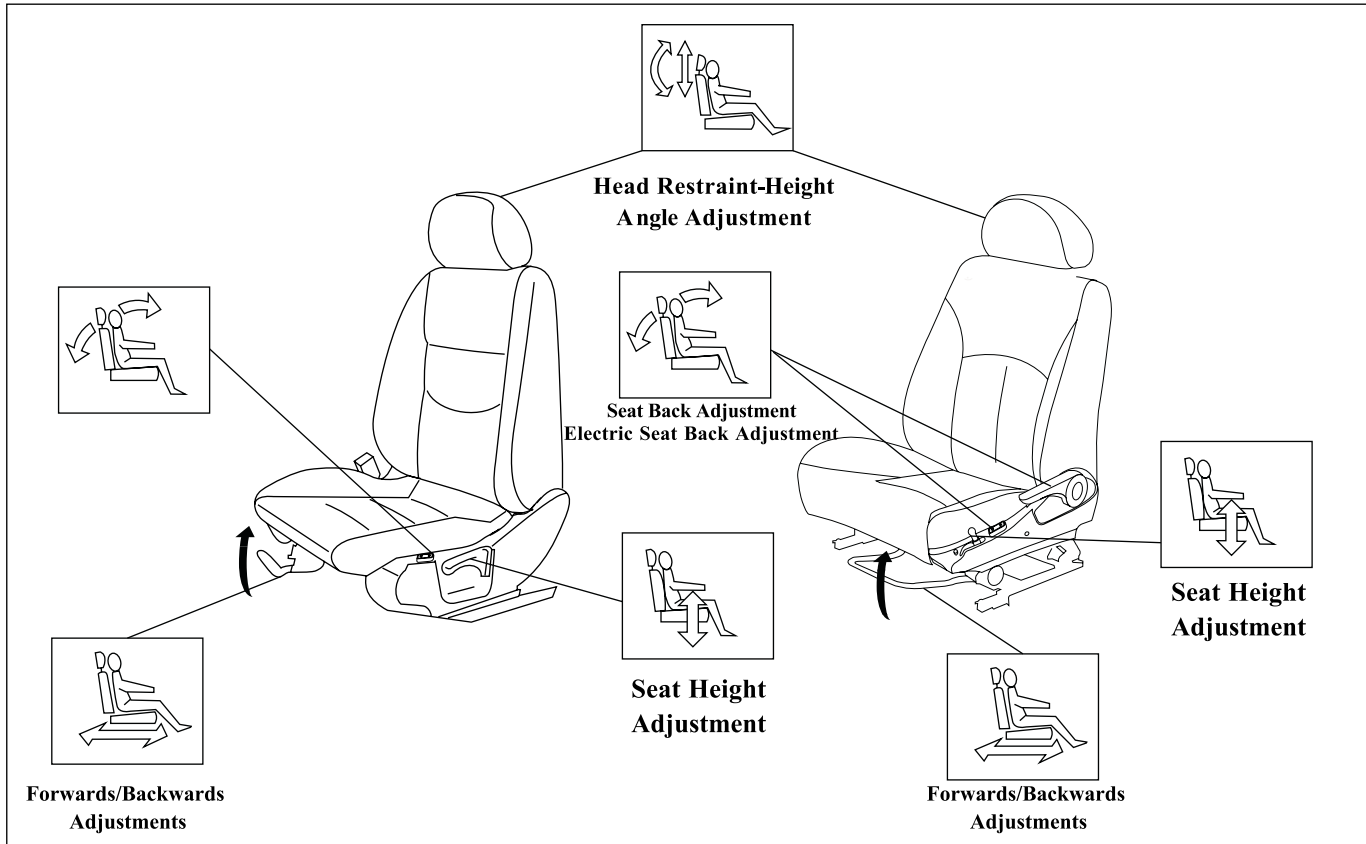

*If equipped

PARS AT A GLANCE

1

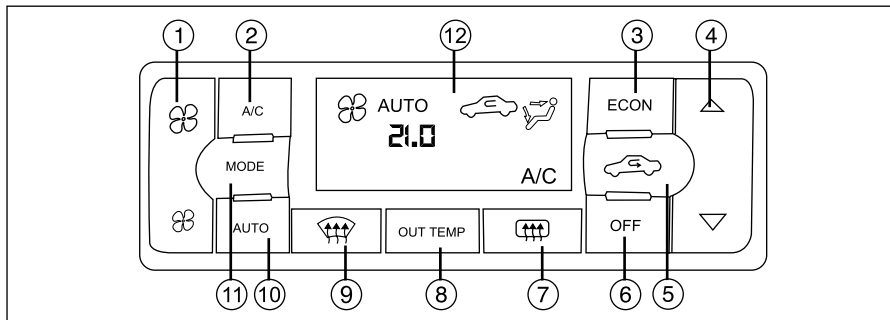

Automatic pleasant ventilation

- 1- Control of non- automatic fan.
- 2- Cooler
- 3- Economic consumption.
- 4- Adjusting temperature
- 5- Internal circulation of the Air.
- 6- Off.

7- Rear window heater .

8- Outside Temperature indicator

9- Front window vent(wiping vapor)

10- Automatic mode .

11- Selection of non-automatic vent control.

12- Display screen (LCD)

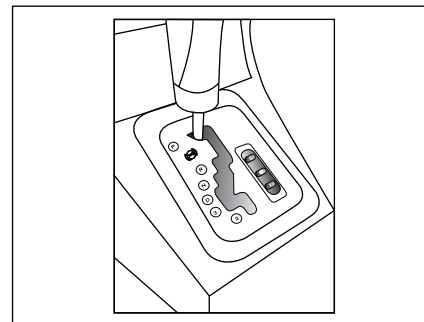

Automatic gear: *

When starting, set gear lever to N or P position.

The brake pedal must be pressed at the time of starting the vehicle or selecting the front or rear gears.

The position of the gears with a light is indicated on the front of the dashboard.

Description of the gear position:

P Park **R** Racing

N Neutral

D Driving: In this situation, all four gears are automatically replaced.

3 The first three gears

1 Only in gear 1 **S** reverse gear

☸ Snowing

2 The first two gears

*If equipped

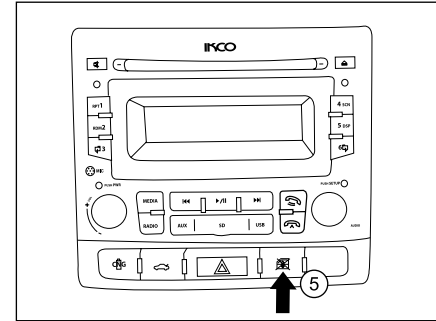
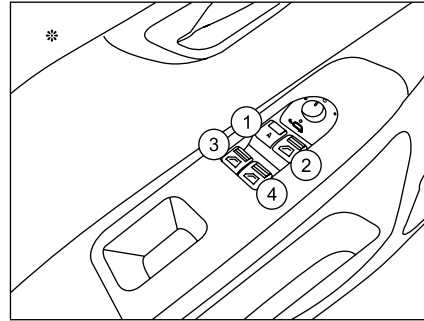
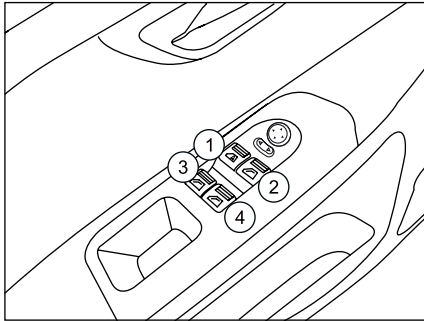

Electric side glass lifter *

1- Electric Side glass lifter of driver

Manual mode: Press or pull the key gently; the glass stops moving soon after realizing the key.

Auto mode: Press or pull the key severely and continuously; the glass gets opened or closed completely.

(Automatic opening of glass is possible in all switch modes). *

(For closing of glass automatically, the engine must be turned on).*

2- Electric side glass lifter of passenger.

3-left and rear side Electric glass lifter.

4- Right and rear Electric glass lifter.

Electrically regulating the mirror



WARNING

The electric side glass lifters of the vehicle, with using Anti pinch safety system, only avoids the large damages due to excessive forces. Therefore, it is advised that always take usual precautions.

5- locking key of rear glass lifter :

This key prevent the function of rear glass lifter keys .

Rear and front electric side glass lifters will function ,while the ignition switch is on.

Glasses keys *

Any passenger can open or close his/her own side glass.

*If equipped

PARS AT A GLANCE

1

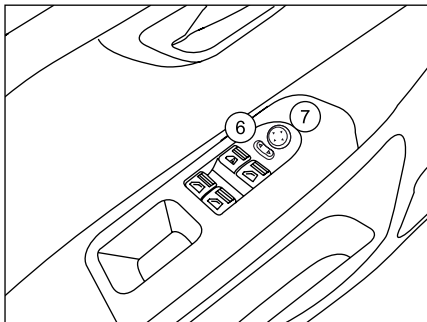

Adjusting Electric mirrors:

Before adjusting, bring the mirror to its normal position with your hand, from outside.

6- Selecting the right or left mirror for adjustment:

By pushing the switch to the right or left, the mirror on the same side will be ready to get adjusted.

7- Electrical adjusting of the mirrors:

With the help of related switch, which can be moved in all four directions, adjust the mirror at your desired position. Then bring back the switch no.6 to its middle position.

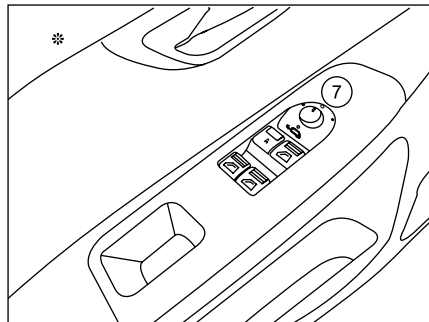

Turn the switch 7 to right or left, then adjust the desired mirror in four directions by pressing the same switch.



In addition to open and close the Mirror via radio remote control, rotating 90 degrees key 6 clockwise and counterclockwise, mirrors alternatively open and closed.

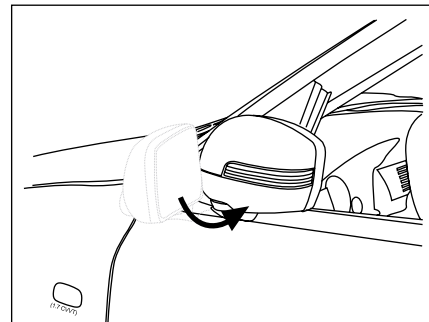

Electric folding mirror:*

In electric folding mirrors, without any need to use hands, simultaneously open and close with opening and closing of vehicle doors through remote control automatically.

The folding mirror is closed after 2 seconds of the first remote and 10 seconds by the 2nd remote. But the mirrors and doors are opened together, soon after soon after pressing of the opening button on remote. If the flasher is used, then the lamps on the folding mirrors start blinking simultaneously with relevant flasher.

*If equipped

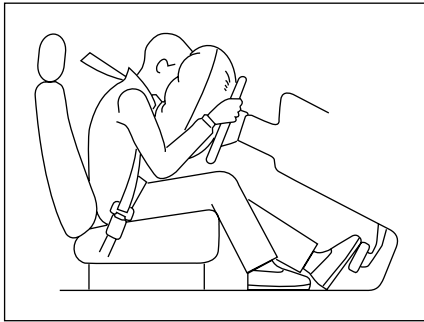



Air bag safety

Your vehicle is equipped with Air bag in addition to the pre-tensioner seat belt. The Air Bag is activated and protecting all passengers soon after the accident. When the ignition switch  is turned to the “ON” position, air bag indicator on the instrument cluster gets on and will get turn off again after blinking for 6 times. Please refer to the authorized representative of IKCO, in case of observing any changes in indicator functions.



Disabling of the passenger airbag

Disabling of the passenger airbag The Disable Key of the passenger airbag is located on lateral side of dashboard section and provides the possibility of activating or inactivating passenger air bag. The warning light of deactivation mode is turned on, on instrument panel () , if the Air bag is deactivated.

WARNING 

Enabling or disabling front passenger air bag Should be done, when the vehicle is in off position. The relevant warning light of deactivation must be turned off () Immediately after reactivating the Air bag.

WARNING



In the event of an accident, there is serious injuries for driver and passengers, if they don't wear a seat belt bend forward, or are positioned out of the chair. Holding the driver's hand on the blades or central parts of the steering, placing legs on the dashboard and being too close to the air bag, will cause injury to the passengers in the accident while creating functional impairment of safety system.

1

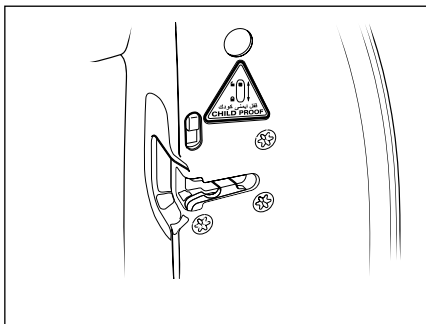

Child safety locks

Positioned under the each rear door lock. The child locks prevent the opening of rear doors from the inside and act independent of the central (door) locking system. To latch the children just push the lever down to operate.

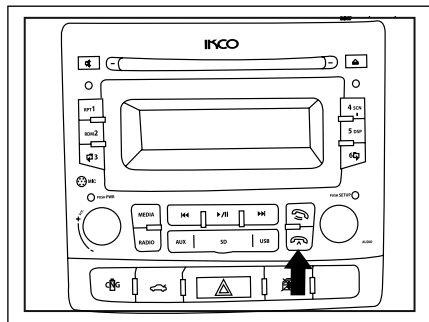

Hands-free cellphone (Bluetooth)

Equipping your car with Hands-Free telephone (with Bluetooth) means that Hands-Free kit can manage your communication without usage of your cell phone in the regular way. Even if the mobile phone is inside the attaché-case or the pocket of the user, the call acceptance or refusal key is located on the dashboard console.

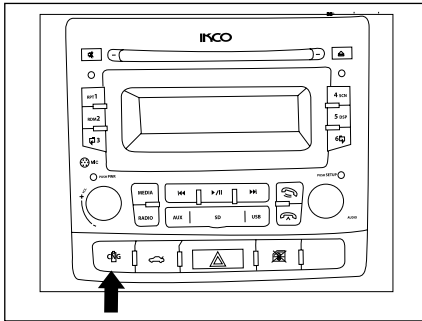

Ignition and driving on CNG fuel mode*

The engine is always ignited on gasoline. The fuel conversion is carried out by the conversion key on the middle console. The CNG fuel selection is possible in the following situation:

- a) Before starting
- b) While driving
- c) Igniting the car on the gas mode directly

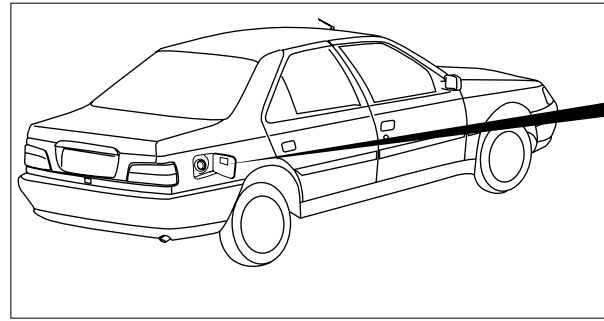

A premium petrol with octan(ROn) 95 must be used. Avoid entering the nozzle into the tank completely. Applying the fuel additives aren't permitted for this vehicle.

Fuel type

The fuel used on your car unleaded premium gasoline with octane number (RON) of 95. In the event a fuel other than that specified above is used, the internal parts may get damaged because of the auto-ignition and knocking.



WARNING
The failure to use non-leaded premium gasoline will damage the catalytic converter. Avoid strictly of combining any liquid with the standard fuel.

*If equipped

PARS AT A GLANCE

1

Audio system control panel

- 1- Off/ On
- volume turning :Sound adjustment .
- 2- Mute
- 3- Disc Input
- 4- Disply screen
- 5- Eject button.
- 6- Manual adjustment of frequency .
- Selecting previous/next music.
- 7-Response to received call.
- 8- rejection.
- 9- Automatic search for stations by increase of frequency.
- Selecting next music.
- 10- play/stop
- 11-Automatic search for stations by decrease of frequency..
- Selecting previous music.
- 12- USB/SC/AUX cap
- 13- Exchange of radio bands.
- 14- Selecting of player(CD/USB/SD/ AUXIN)

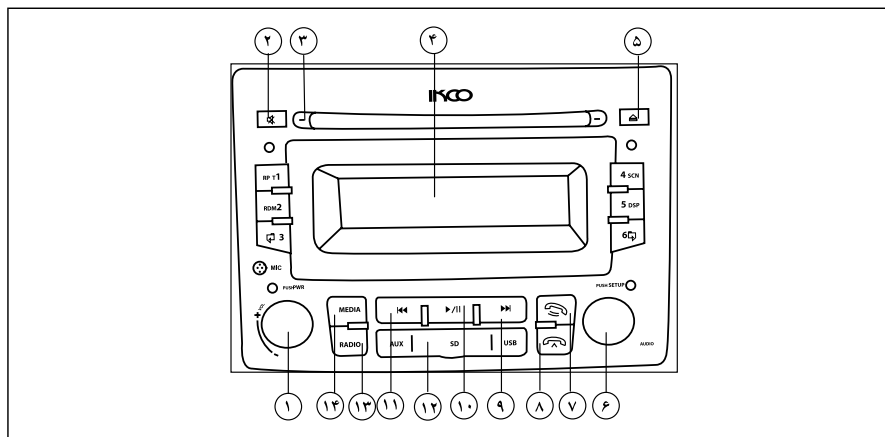

2 BEFORE DRIVING

LOCKING/UNLOCKING	24	LIGHTS AND INDICATORS	44
IMMOBILIZER	28	GLASS CLEANERS AND WINDSHIELD WIPER	46
ELECTRIC SIDEGLASS LIFTER	29	REVERSE GEAR WARNING SYSTEM	47
INTELLIGENT WINDSCREEN*	31	HANDSFREE CELL PHONE	48
SEATS.....	33	AUDIO SYSTEM	50
SAFETY BELTS	36	AUTOMATIC AIR CONDITIONING	63
CHILD SAFETY	38	CNG PARTS *	66
MIRRORS	40	ANTI-LOCK BRAKING SYSTEM	68
FOLDING EXTERIOR MIRROR(ELECTRICAL)*	41	INTERIOR EQUIPMENT	70
FIRE EXSTINGUISHER *	42	AIR BAG	73

*If equipped

LOCKING / UNLOCKING

2

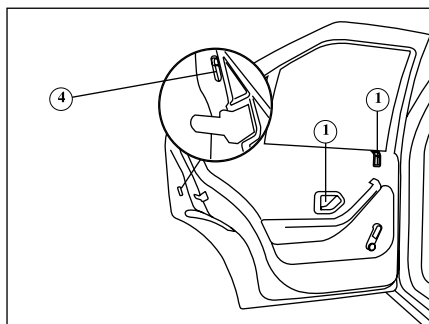

Locking and unlocking of the doors:
Side doors, rear trunk door, fuel tank cap cover:

1- With the use of key:

For opening the door, pull up the external handle.

From inside:

Push down the interior locking button, door will be locked. For opening the lock, pull up the same button and for opening the door, pull the interior handle.

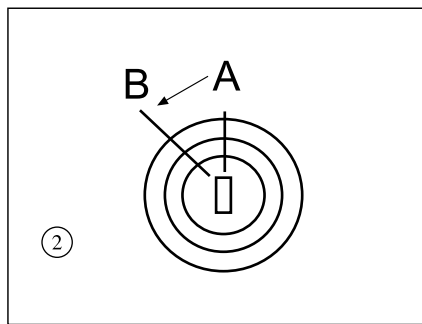

2- With the use of key (switch) and central locking system:

All doors, rear trunk and fuel tank cap cover, can be opened or closed simultaneously with the help of switch key from outside and the locking buttons on front doors from inside.

Meanwhile, by using the front doors lock button, we can only lock the trunk lid. For opening that, we should use the switch.*

Vehicle: after locking doors by central locking system, the rear trunk door can be opened by the use of main switch key and it's turning anti clockwise (from A to B).

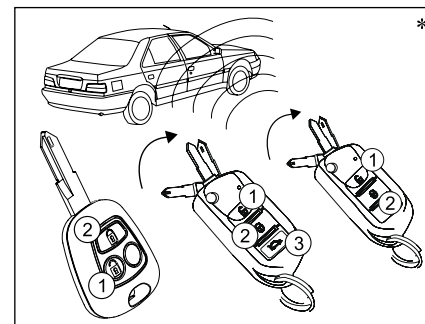

3-With the use of remote control: *

Keep the remote control key towards the car:

- Press the key no.1 to open the door. (anti theft system will be turned off)
- Press the key no.2 to lock the door. (anti theft system will be turned on)
- The boot will get open by two successive pressing or in some models holding the key for 5 seconds.

4- Children safety lock:

To avoid opening of rear doors from inside, push down the safety lock button.

NOTE

Frequent pressing of the keys in short intervals will cause the keys functioning cessation for 20 seconds.

*If equipped

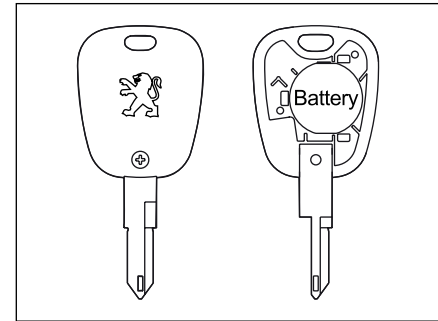
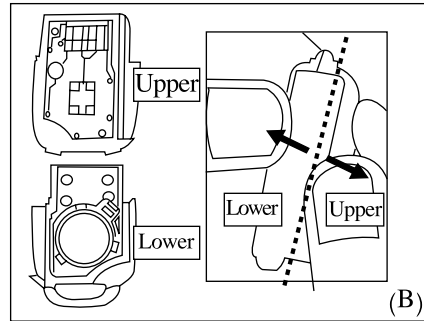
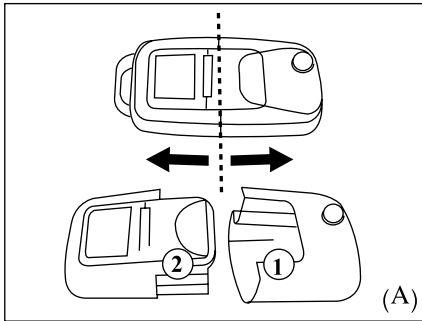

Battery Replacement of the Remote Control Switch

If the indicator light on switch is not blinked or the key is not functioned correctly, it is necessary the battery be replaced.

- 1- Separate the part 1 and 2 with the help of hand pressing from the described line.
- 2- Then separate the upper and Lower part of the section 2 by hand pressing (fig B).
- 3- Remove the discharged battery and replace the new one. Ensure the battery has been inserted properly(fig C).Use the battery of CR 2032.
- 4- Put the upper and lower part on each other and insert it by hand pressing.
- 5- Put part 1 and 2 on each other and insert it by hand pressing.

WARNING 
 Never discard used batteries in nature. Give them to organizations responsible for collecting and recycling this kind of batteries.

WARNING 
 Avoid keeping the battery or remote controller in infants' access, because swallowing of the battery can cause death. In case of swallowing the battery, refer to health care centers immediately.

Battery replacement of the remote control*

If the key is not functioned correctly, it is necessary the battery be replaced. For replacement of the battery, first open the buckle and separate the switch back frame with proper pressure to gap between up/down frame. Confirmed battery is CR2032.

Remember, even, when the remote control batteries have been discharged, central key system operates by the key. If it's possible, don't utilize used batteries.

2

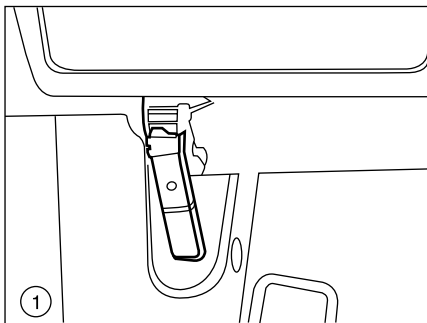

Locking and unlocking of the engine cover door:

1- From inside: Pull the interior handle below the dashboard until the lock is released.

2- From outside: pull the safety holder beneath the engine cover door towards

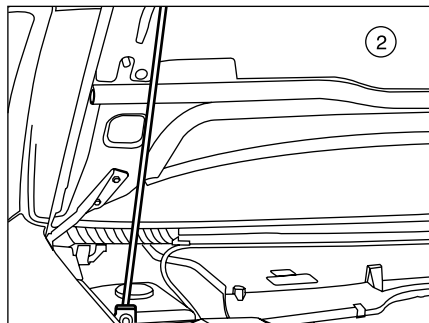

yourself until the safety lock is released. To keep the engine door open, use the leaning rod. To close the engine door, bring down the leaning rod and **leave the door to drop by itself from a distance about 30 centimeters**. Make sure that the door is completely locked.

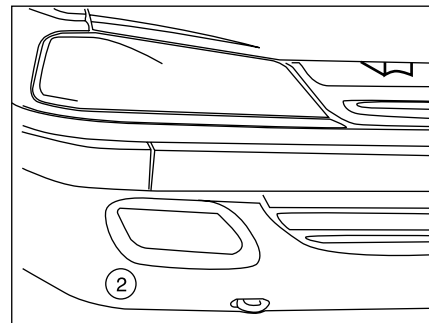

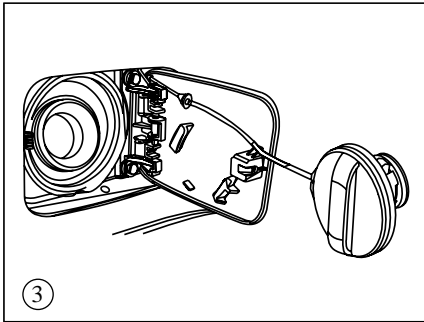

Fuel Filler Flap

3- To open Fuel Filler Flap press the frontal flap of tank valve. There is a place on internal side wall of valve to keep the lid to prevent being lost.

(Before completely removing of tank lid wait for a few moments until the present gases in the tank gets out.)

Fuel filler flap has been joint to the Tank vent to prevent to be lost.

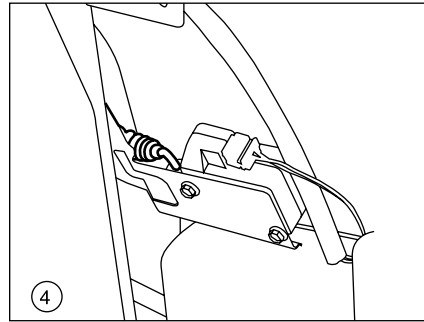

Opening the fuel filler flap in emergency situations

4- If the central locking system does not operate, you can open the flap from inside the trunk.

- Remove the upholstery of the inner right wall of the trunk.
- Pull back the tongue of the fuel filler-flap lock.



CAUTION

The utilizable gasoline in engines is unleaded gasoline octane 95. If any other fuel is consumed, it is possible to damage internal parts due auto-ignition phenomenon and impact. Avoid entering the nozzle into the tank completely. Applying the fuel additives aren't permitted for this vehicle.



WARNING

Since the gasoline in the fuel tank maybe under pressure, never open the fuel cap suddenly in order to prevent danger. Loose the cap slowly and carefully till the HISS sound stops, and then open tthe cap fully. Considering the danger of gas mist, never fill the fuel tank while the engine is running. Please keep away of any sparkles, flames... near the spilt gas.

ANTI-THEFT SECURITY SYSTEM (IMMOBILIZER)

2

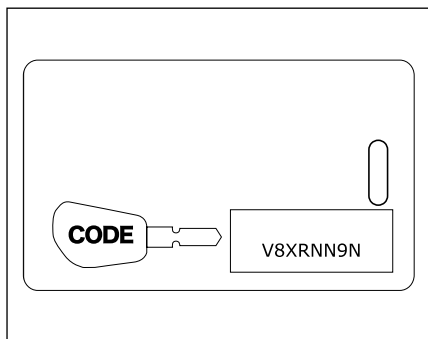

Anti-Theft Security System (Immobilizer)

The vehicle with immobilizer system, can only start up with two keys which is delivered to customer with the vehicle.

NOTICE:

- Copying key is not enough for start up. It is possible to have more keys if the customer requests and only in IRAN KHODRO dealers with the DIAG tool.
- A number has been carved on the key plate for replacing the key. Therefore keep the plate in a safe place and never inside the car.

*If equipped

To maintain better and usage of your vehicle, it is necessary to pay attention to the following tips:

1. Keys have electronic chip inside which contains information of key codes, so avoid putting them near powerful electro magnetic and electrical scopes.
2. When delivery the vehicle, there is a card which is shown in left picture with the keys. Existence of this card is necessary in cases like multiplying the key (from 2 up 5 at max) or replacement of lost key, replacement of electronic unit of Anti-theft security system (immobilizer) or replacement of ECU with ownership document of vehicle. Above functions are impossible if the card is lost and leads to replace whole security system. All costs due to careless keeping must be paid by owner.

ATTENTION

This system will check the engine's electronic system, a little after the engine is turned off and thus prevent anyone without the main key from turning on the engine.

NOTE

There is possibility of breakage for internal parts of the remote controller in case of severe impact and subsequently not functioning of the immobilizer.



CAUTION

- The anti-theft system your vehicle is equipped with is one of the soundest security systems, increasing the vehicle's security ratio, without need of doing any special functions. Naturally this should not make the vehicle owner careless regarding proper and adequate protection of his car.
- Any repairs or changes in the anti-burglary system (electronic box, wiring, etc.) are strictly forbidden.

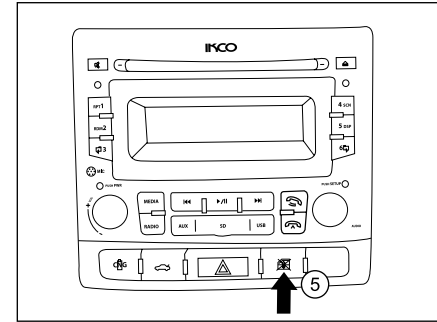
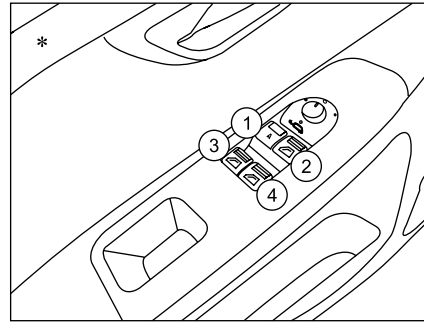
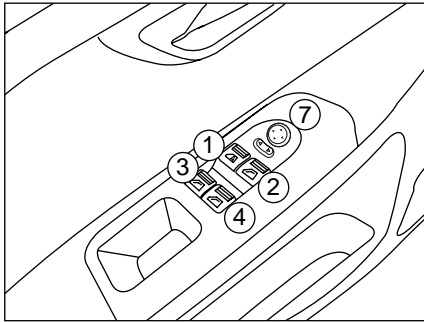

Electric side glass lifter

1- Electric Side glass lifter of driver

Manual mode : Press or pull the key gently; the glass stops moving soon after realizing the key.

Auto mode : Press or pull the key severely and continuously ; the glass gets opened or closed completely .

(Automatic opening of glass is possible in all switch modes). *

(For closing of glass automatically, the engine must be turned on).*

2- Electric side glass lifter of passenger.

3-left and rear side Electric glass lifter.

4- Right and rear Electric glass lifter.

5- locking key of rear glass lifter :

This key prevent the function of rear glass lifter keys .

Rear and front electric side glass lifters will function, 30 seconds after deactivating ignition switch or while it is on.

*If equipped

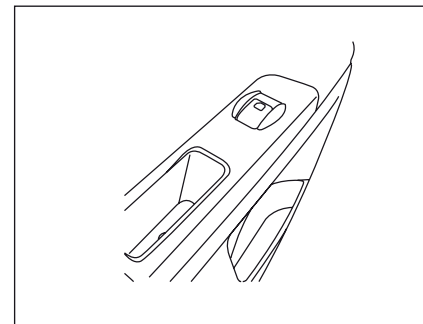

Glasses keys

Any passenger can open or close his/her own side glass.



WARNING

The electric side glass lifters of the vehicle, with using Anti pinch safety system, only avoids the large damages due to excessive forces. Therefore, it is advised that always take usual precautions.



WARNING

- Never leave a car in which an infant or pet animal is seated with the switch card in the car. Indeed the infant or the pet animal can operate the electrical windscreen switch and get caught (by head, arm, hand etc) in the opened windscreen, thereby inflicting heavy injuries to oneself. In the event the windscreen has caught the infant or the pet animal, immediately operate the windscreen in the reverse direction.
- A power window won't stop if your fingers, hand(s) or head get in the way. you or others could be seriously injured.

Intelligent windscreen Switches*

The new intelligent windscreen switch installed in your vehicle is endowed with an electronic board providing the following advantages:

- 1- Anti-Pinch safety system
- 2- Automatic closing the windscreens while leaving the vehicle
- 3- Automatic shift command of the four windscreens
- 4-Slow coming to a halt of the windscreen at the end of the course.

Anti-pinch safety system

This is a safety system which prevents the body parts from getting caught while the windscreen switch is on its upward course. In this system if the windscreen gets in contact with an obstacle while in its upward course, it comes to a halt immediately and moves in the reverse direction, thus it will prevent the inflicting of heavy injuries to the infant. Furthermore, the above system will insure the longer useful life of the windscreen switches.

Automatic window closing

When the vehicle is turned off and its doors locked using remote control, this system will check the car windows one by one and raise the windows that are not closed properly. This security system will take care of security risks of forgetting to close all the car windows and will let the driver leave his car with peace of mind.



WARNING

Despite the anti pinch safety system, the electrical windscreen switches can only prevent the inflicting of heavy injuries caused by the application of the undue force. Therefore, it is advisable to respect the necessary precautions in this regard.



CAUTION

Always make sure all four windows are automatically closed, before leaving car's parking place.

*If equipped

INTELLIGENT WINDSCREEN SWITCHES

2

Automatic order for movement of the four windows

This system will provide the option to lower or raise the windows, both manually and automatically for each window. In ordinary vehicles only raising of the driver's window is automatic.

- Manual mode:

Press the button of the respective windscreen and press it consecutively. As soon as the application of pressure on the button ceases, the windscreen will stop.

-Automatic mode:

By pressing the button once, the windscreen will open or close completely. The new windscreen switches will make you able to open or close manually/ automatically the four windscreens simultaneously. In the event the button is pushed once, the windscreen will automatically go upward or downward course. If the button is pressed consecutively (for a longer time), the windscreen is operated in the upward or downward direction till the pressure exerts on the button; in that case the movement come to a standstill immediately.

Slow coming to a half of the windscreen at the end of the course*

In this system the pace of the window screen will automatically reduce at the end of the course till it stops gradually at the end. In this case, there will be no or less impact on the door. This system eliminates the unpleasant noise arising from the sudden stoppage of the switch at its final course and increases the useful life of the internal door parts. (Obviously the anti-pinch system is operated automatically and in the event the windscreen gets in contact with an obstacle while in its upward course, it comes to a halt immediately and moves in the reverse direction).

note: The intelligent windscreen switch is equipped with a sensor which precisely registers the windscreen position at any moment. To distinguish the starting and finishing points of the windscreen movement domain, the preliminary readjustments of the windscreen electronic system are made in the factory. If for any reason such the opening of the battery leads the permanent energizing of the window switch ceases, the preliminary adjustments are wiped from

the memory and the new abilities of the intelligent window switch cease to operate. Following the permanent re-energizing of the system, the preliminary readjustments and start-up of the windscreen switch have to be made again.

This includes the following stages and could be easily done by the owner in the following manner:

- 1- Lower the windscreen to the end of the course.
- 2- Raise the windscreen manually to the end of the course (In automatic mode, it will be deactivated).
- 3- Upon the movement of the windscreen to the end of the course, hold the button just for a second.

NOTE

While adjusting the system, the anti-pinch system is deactivated.

*If equipped

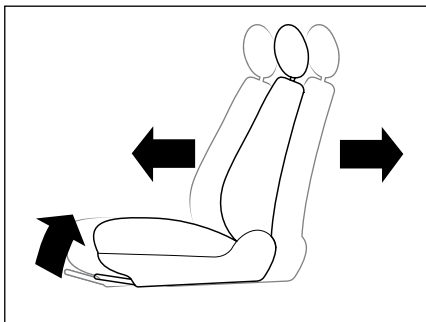

Forwards and backwards of the seat

- 1- Pull the control lever upwards.
- 2- Take the seat to the favorite position with the help of your body.
- 3- Release the lever until it gets locked. ensure the seat is tighten on its own position firmly before moving

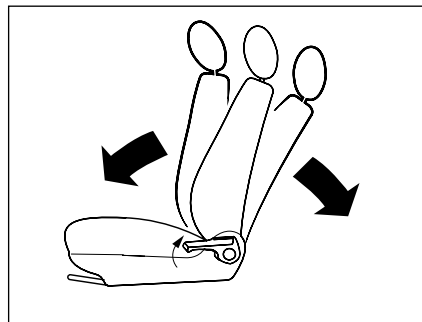

Adjustment of seat back

- 1-Turn the control lever upwards.
- 2- Take the seat to the favorite position with the help of your body.
- 3- Release the lever until it gets locked. Ensure the seat is tighten on its own position firmly before moving.

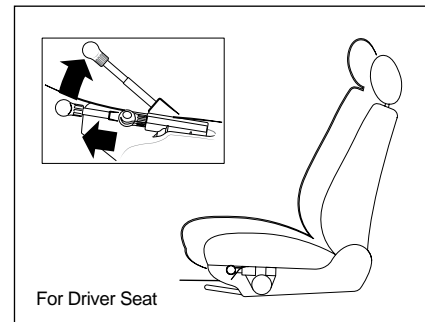

For Driver Seat

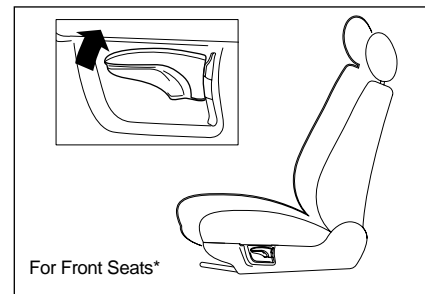

For Front Seats*

WARNING



- Seatbacks should always be in upright position when vehicle is moving. Seat belts are designed to offer maximum protection when seatbacks angle with vertical line is about 25 degrees.
- Do not adjust the seat when vehicle is moving.
- In order to install the seat cover for the second time, be careful that the seat cover clamps are not being hindering of the action of the driver's seat regulation rods.
- Open and close the chair must be performed in accordance with procedures and safety tips. If necessary to open and close the seat, must certainly refer to authorized repair shops.

Seat height adjustment *

To adjust the seat ;pull the lever upwards (for increase of height) and press the lever downwards (for decrease of height) while you're sitting on the seat.

*If equipped

SEATS

2

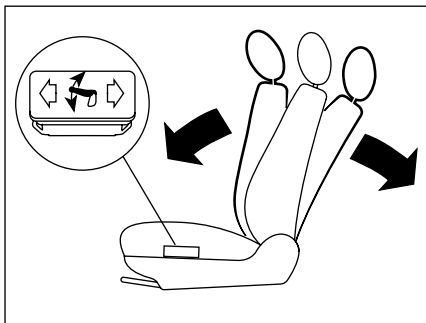

Electrical adjustment of Seat back

Press the electrical adjusting key for seat back adjustment after you turning on the ignition switch; so that the seat back is located in your favorite position.



WARNING

Make sure the leg of the rear passenger is not under the seat when you lower your seat.

Do not adjust the seat while driving.

Since the head restraint is a safety device, make sure it is properly secured in its place.

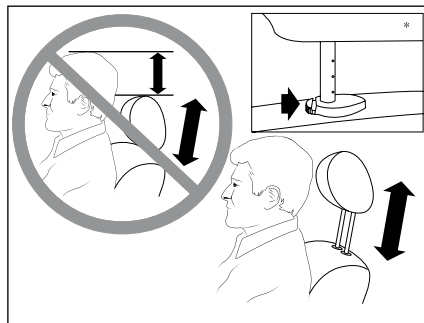

Adjusting head restraints

Pull head restraint upward to be level with the head. To lower the restraint, push down on the restraint.

(Press the lock latch towards the inside first; and then pull the seat back downwards or upwards)*

Note: since removing of the head restraint is very difficult and may damage the seat. Except in emergency cases do not remove head restraint.



WARNING

It is necessary to adjust the height of the head restraint with the head position, as per the above illustrations, in order to reduce safety hazards to driver and front passenger.

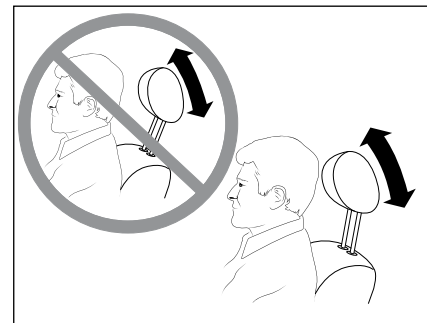

Head position

Head restraints are designed to protect the head from being thrown back in case of an accident or sudden stops. Its proper adjustment reduces the risk of head and neck injuries.

Meanwhile the head restraint is movable forwards and backwards in its position (see above figure)

*If equipped

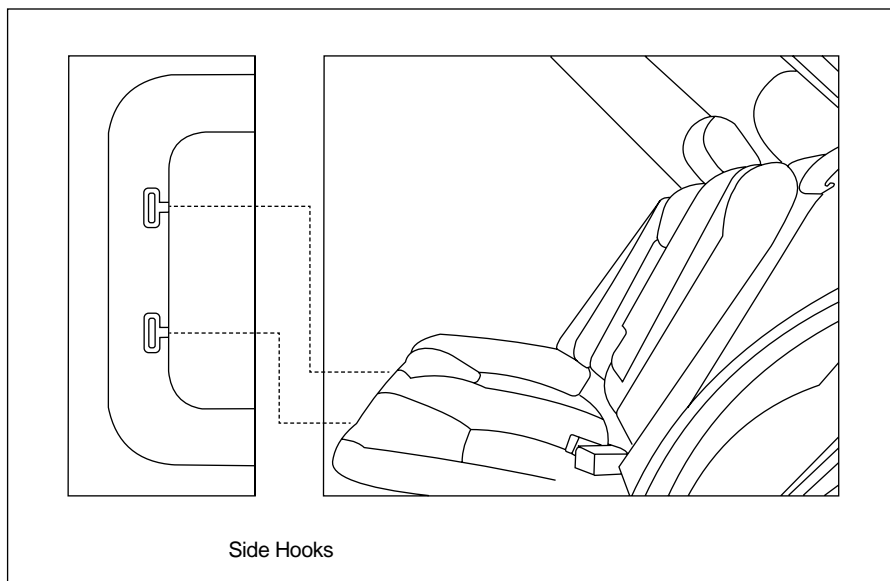

Rear Seats:

In PEUGEOT PARS, the back seat is in one piece. To take the seat out, pull up the middle front edge of the seat a little bit until the peaks of the hooks on sides of the seat comes out. Then take out the seat away from leaning part. To take out

the leaning part, from the rear trunk , bring the carpet to a side, with the help of an especial hook, dislocate the peaks of the hooks on leaning part and simultaneously pull up the leaning part, so that the upper hooks are also released.

*If equipped



CAUTION

Do not put extra or thick matt under the Driver's feet, because none standard matt restricts the complete course of clutch and smooth changing of gears.

2



WARNING

Make sure that during lowering the seat, the foot of the back passenger dose not come under the seat.

-In spite of the fact that the headrest is a safety device, make sure about it's presence, correct location and correct position.

-There should not be any device placed on the floor (In front of Driver side), because in case of intense braking, these devices can be shifted beneath thePedals and restrict using of them.

- Do not adjust the seat when vehicle is moving.

SAFETY BELTS

2



Fastening the belt :

Pass the seat belt across the shoulder and the chest and assure not to be twisted. Insert the metal latch in the special lock so that you can hear the sound of clop after insertion .By doing this the relevant warning light of seat belt gets off on instrument cluster.

Release of the seat belt :

Press the red knob on the belt lock. Belt are designed in such a manner to include the whole body and are useful only while they're in vertical position.

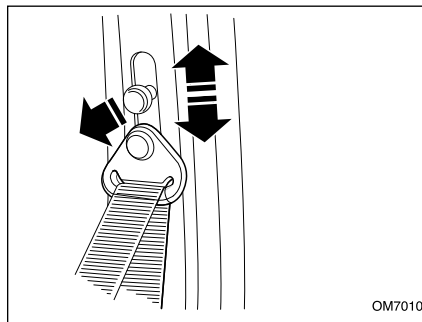

Height adjustment of front seat belt :

Pull out the adjusting knob and take it up or down for a few scale.

It's better for the children to use only from rear seat belts.



WARNING

Seat belt are useful only while they're near to the vertical position .Don't allow the front passengers to use the seat with declined position. By doing this the relevant warning light of seat belt gets off on instrument cluster.

The belt equipped with power restricting system

At the time of accident the safety will be increased via this system and the impact result in accident will be decreased on the chest by utilizing the system.

the belt equipped with power restricting system functions only once at the time of air bag being activated and after one function ,it must be changed by authorized IKCO representatives.



WARNINGS

To not reduce the effectiveness of safety belts and to prevent injury, place belt shoulder pad on the shoulder. Make sure that the backrest is placed in the proper location. Avoid any external or sticky material to enter the lock slit; causing the improper function of the lock .

Seat Belts Safety Tips

Seat belts are designed for people of adult size, and they must be used by only one person at a time. Always make sure that all passengers' belts are fastened (properly), and consider the following.

Precautions:

- Do not let passengers recline the seats extremely rearwards. The complete performance is gained when backrest angle is about 25 ° from vertical axis.
- Adjust safety belts to eliminate any slacks. Do not pull the belt away from the body while running. To operate properly, safety belts should be worn as tightly as possible.
- The lap part of the belt should not go over the abdomen but pelvic bones. The shoulder belt should go over the shoulder and across the chest without any pressure to the neck.
- Remove hard, sharp or fragile objects as keys, pens, glasses and etc. from your clothes. The belt should not be twisted, and there would be no obstacle in between.
- Replace seat belts if they are worn, lost their sensitivity or damaged.
- Use the seat belts to fix luggage carried

on the seats. Throwing loose packages in passengers' compartment during an accident can cause serious injuries.

- In most countries, all passengers are legally obligated to wear safety belts unless be exempted on medical certificate.
- Pregnant women should pass the shoulder portion across the shoulder, breast cleavage and from one side of the fetus. If in doubt, consult your physician.
- The belt is equipped with power restricting system to control the impact incurred to the passenger chest in any probable accidents.

CHILD SAFETY

2

NOTICE:

People under the age of 7 or 8 are considered children because of the different ratio of head to body weights.

In violent deceleration, the weight of the head and the relative weakness of the neck muscle can make serious spinal injuries. They can be considered as young children until they reach 10 years of age or at a height of more than 135 centimeters.

This is why most countries have envisaged some rules for the purpose of using and selling suitable child restraints.

The seat of the child from 9 months to 3 years (up to 18 Kg) should be placed forward-facing in the rear of the car and

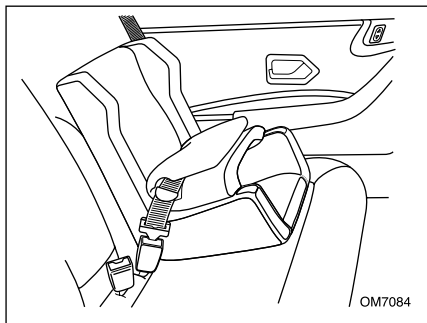

fixed with a three-point belt (lap-and-shoulder or inertia reel belt).

Babies under the 9 months (and less than 10 kg) must be secured on a rear-facing seat in front of the car. Actually infant

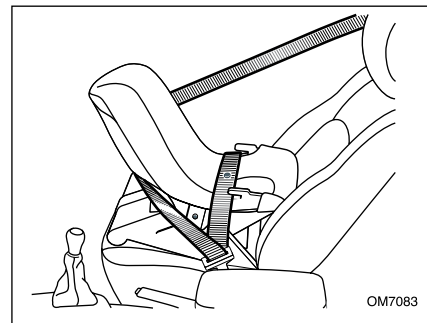

restraints provide restraint with the seating surface against the back of the car with a three-point seat belt with locking mechanisms (or inertia reel belt).



WARNING

Nothing should be placed under the driver's feet; otherwise it may slide under the pedals by a sharp braking and lead to malfunction of the brake in an emergency situation.



WARNING

Make sure of air bag deactivation while the infant seat back is located towards the road in front passenger seat; otherwise there is every possibility of severe injury or even death of the infant due to air bag being opened. Locate the seat in the middle position, longitudinally, adjust the back vertically and activate the air bag while the infant seat is towards the road in front passenger seat.

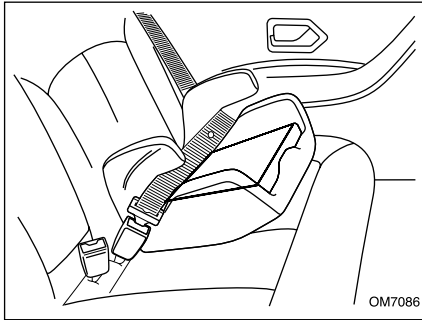

For children (weighing more than 15 kg) equal or greater than 3 years old (more than 15 Kg), a booster seat can be used in the rear of the car, facing forward, using a 2 or 3 point (lap or inertia reel) seat belt (especially suitable for children roughly 3 to 6 years old).

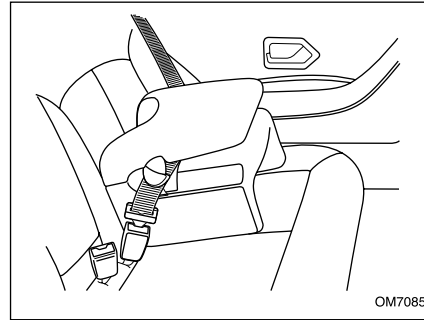

For heavy children – whose weight exceeds the limits of standard seat- who are equal or greater than 3 years old should be seated, a forward- facing booster cushion, in the rear of the car, using a 2 or 3 point (lap or inertia reel) seat belt. (Especially suitable for children roughly 3 to 6 years old).

**WARNING**

- The children shall not be seated on the lap of the passengers; otherwise they may be hurt by an accident.
- Never fasten a seat belt at a time for two persons.

MIRRORS

2

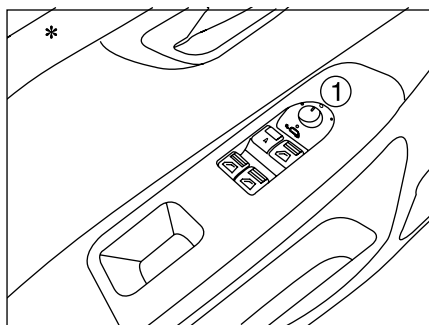

Adjusting Electric mirrors:

1- Selecting the right or left mirror for adjustment:

By pushing the switch 1 to the right or left, the mirror on the same side will be ready to get adjusted.

2- Electrical adjusting of the mirrors:

With the help of switch 1, which can be moved in all four directions, adjust the mirror at your desired position.

Heaters for side mirrors:

To avoid sweating or freezing of side mirrors, switch on the key for heater of the rear glass.

*If equipped

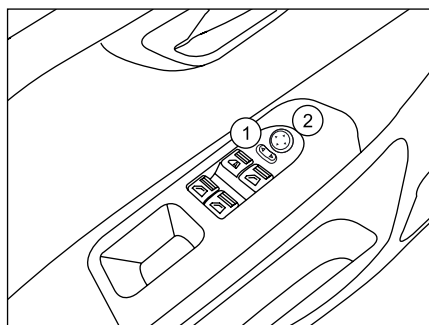

Adjusting Electric mirrors:

1- Selecting the right or left mirror for adjustment:

By pushing the switch 1 to the right or left, the mirror on the same side will be ready to get adjusted.

2- Electrical adjusting of the mirrors:

With the help of switch 1, which can be moved in all four directions, adjust the mirror at your desired position.



In addition to open and close the Mirror via radio remote control, rotating 180 degrees key 1 clockwise and counterclockwise, mirrors alternatively open and closed.

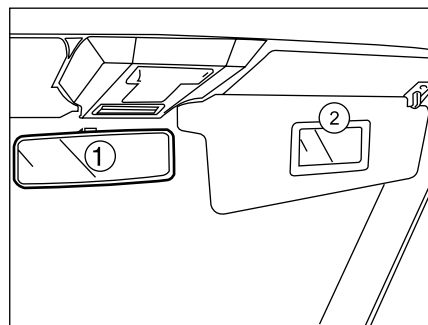

Mirrors:

Rear view mirror: (Inside Mirror)

1- The rear view mirror can be adjusted for driving during daytime or during night time.

2- **Make up mirror:** It is fixed on the right hand side Parasol.

WARNING



The reflect of the objects in the mirror seems farther than their real distance.

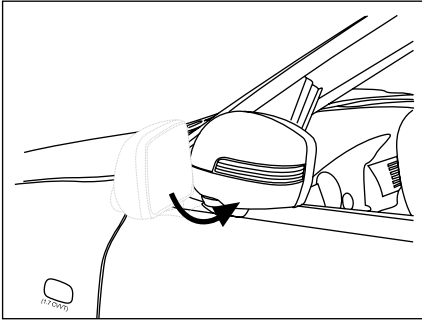

Folding Exterior mirror (Electrical) *

Many of car owners are aware of the advantages of the folding side mirrors especially when the car is parked in a passage. To mention the advantages, one may point to the increase in safety coefficient of the mirror when leaving the car as well as the lower space required for parking the car. Parallel with these and with a view to increasing the comfort of the driver, the electrical exterior folding mirrors are automatic and it can be folded \ unfolded simultaneously by closing the vehicle doors by remote control, no need to manual control.

The folding mirror is closed after 2 seconds of the first remote and 10

seconds by the 2nd remote. But the mirrors and doors are opened together, soon after soon after pressing of the opening button on remote.

The manufacturing technology of these mirrors' motors (called "folding motors") is designed in such a manner that in the event of any impact, the motor will be locked and current voltage will be cut off. This mechanism prevents the damage of the motor as well as the destruction of the mirror in itself by the application of undue force.

If the flasher is used ,then the lamps on the folding mirrors starts blinking simultaneously with relevant flasher.

*If equipped

FIRE EXTINGUISHER

2

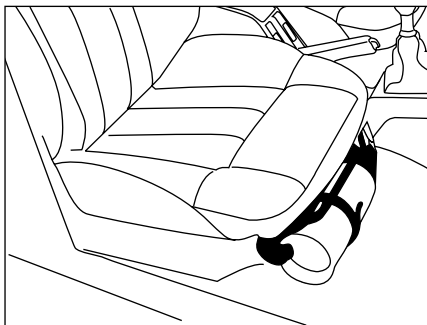

Fire Extinguisher*

It is necessary that owners learn about usage of car extinguisher.

Product Specification:

1. This kind of capsule contains dry chemical powder with 16 gr high pressure CO₂ cartridge (capsule). During operation, after release cotter pin, gas inside cartridge will mixed with dry powder and mixture is ready to void.
2. Maintenance and operational accordance within -30 to 90° C temperature.

3. This kind of capsule doesn't need to be checked for 5 years and if it is used, it will be easy to recharge again.

4. Non conglomeration of powder in the case of any car vibration, high temperature and car accident is one of the pros of this capsule.

How to use:

Activation procedure of capsule is written in English language on it's body as follow which must be read carefully.

- Pull out cotter pin
- Pull out cap cotter pin upward
- Aim the nozzle toward fire center and press handle downward for powder discharge

NOTICE

To prevent of fire expanding due to air feeding in engine compartment, do not open the hood completely. After release cotter pin and activation the capsule, open the hood about 10 to 15 cm with discretion and care then simultaneously discharge the mixture in fire center about 1 to 2 seconds. After that open the hood and completely discharge the capsule in fire center. Pay attention that the capsule weight is 1 kg and it's discharge duration is about 7 –10 seconds. there fore paying attention during operation is so necessary.

*If equipped

Important tips:

- 1.Never open discharge valve of fire extinguisher. This cause to lose quality of material inside fire extinguisher and reduces it's power.
- 2.If the door and windows are locked and impossible to open due to fire emergency or emergency conditions, take the fire extinguisher which is placed under front passenger seat and break the window by its end then exit the car.
- 3.Although the material inside fire extinguisher is not poisoning, never discharge it toward face and eyes.
- 4.During installation inside the car, pay attention that fire extinguisher is well placed and it's plastic mounting belt is properly locked, otherwise in case of impact or accident it moves from it's place.

- 5.During fire emergency, always be cool and follow the procedure carefully.
- 6.The 1 kg fire extinguisher is just designed for control and restrains the fire at beginning so in case of fire emergency which expands in large area, notify the fire department to help and control the fire. The mentioned fire extinguisher has no efficiency in above case.



CAUTION

Experience and coolness are two fundamental skills during usage of fire extinguisher, so car manufacturer has no commitment to owner due to non correct usage of fire extinguisher.

Safety precautions to avoid stealing of vehicle:

Always follow these safety precautions even when you are leaving your car for few minutes:

- 1- Close the glass windows completely.
- 2- Take your valuable belongings with you, or hide them at the rear trunk.
- 3- Do not leave the switch key inside.
- 4- Lock the steering wheel (when the engine is off, the steering wheel will be locked by slight turning it to the sides)
- 5-Lock all the doors.

Other than above precautions, you can also think about ways to reduce possibility of stealing your car.



CAUTION

- Avoid parking your car in unattended on- street parking spaces.
- Avoid parking in dark places.
- Never leave the car's documents or spare keys in your vehicle.
- Park in your garage if you have one, and take the switch with you.

LAMPS / INDICATORS

2

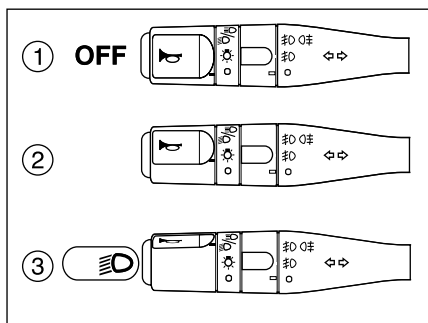

Lever's setting for lights

Status 1: all lights on.

Status 2: passing beam, tail light,
instrument panel

Status 3: headlights on

Warning beep

This warning beep will be heard if the driver is leaving the car while the headlights are on, the driver's door (and or passenger)* is open and the switch is off.



WARNING

Ensure the following items before driving at night:

Please be ensured of correct performance of electrical equipment and vehicle lights.

In case of vehicle overload, please make sure that the lights are not covered. (make sure that some dirty material, snow or other things are not covering the lights.)

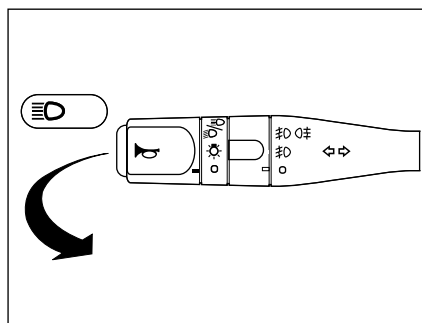

High & Low Beam

Push the lever completely towards the steering wheel in order to change the status of low/high beam. (blue indicator light will be displayed to show high beam status). In order to flash high beam at once, push the lever near the steering wheel and release it immediately.

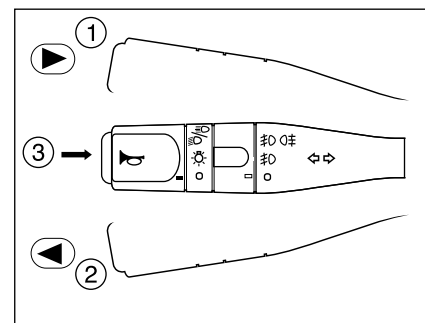

Left and right indicator light

Status 1 & 2: Push the turn signal level on downside before turning to left, and to the upside before turning to right. (the green indicator light on instrument panel will flash on turning direction)

Tapping the lever on desired direction will activate the indicator lights for 3 flashes. (number of flashes is adjustable by troubleshooter device.)

Horn

Status 3: Push the end bottom of turn signal lever to horn.

*If equipped

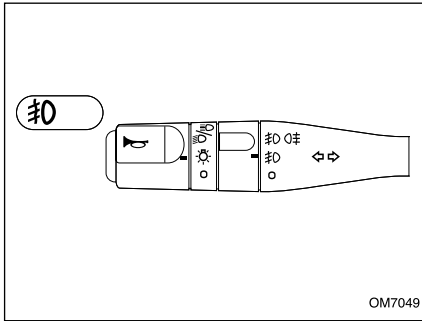

Front Fog Lamps*

Rotate up one level the center part of the stalk to turn on the front fog lights. The warning indicator on the instrument panel lights up simultaneously when fog lights are on.

The lights operate only when the indicator lights are on.

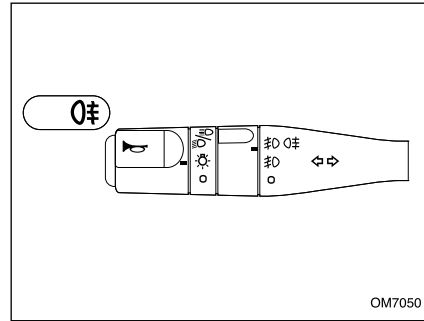

Rear Fog Lamps

Rotate up two levels the center part of the stalk to turn on the rear fog lights. The indicator on the instrument panel lights up when the fog lights are on. The lights operate if:

- Small lights are on
- The sidelights and front fog lights are on (if they are installed)

Fog lights should be used **only** when the visibility area is severely limited since drivers get dazzled when using fog lights in normal conditions.



WARNING

- **Before starting to drive at night:** Ensure proper operation of the electrical equipment and adjust the car's lights. (In case of exceeding normal load), make sure that the lights are not covered. (dirty, mud, snow, or any object on them.)
- Do not use front or rear fog lamp in daylight and night time and rain. Because their glaring lights reduce look of other drivers and increase the likelihood of an accident.
- Fog lamps should be used in snowy and foggy weather.

*If equipped

GLASS CLEANER & WINDSHIELD WIPER

2

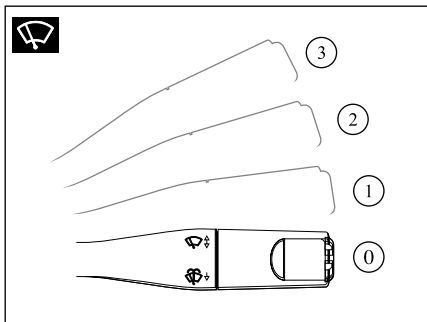

Windshield wiper

Windshield wiper and washer control will be performed by the lever located on right side of the steering wheel when the switch is open.

0- Off status:

1- Time dependent windshield wiper * (interval between two wiper movements will be increased by increasing of vehicle speed.

2- Low speed

3- High speed

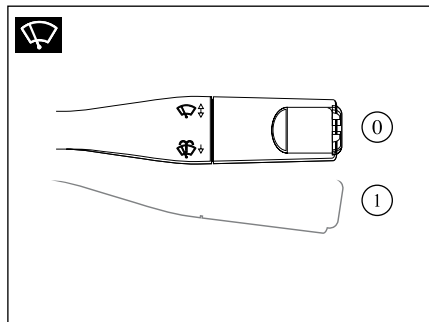

Windshield wiper single cycle

Push the lever once on downside and release it for a single cycle action of the wiper.

Holding the lever down keeps the wiper moving continuously.

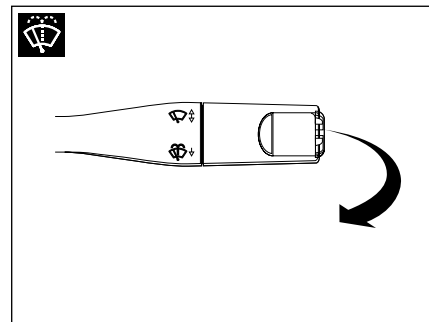

Windshield washing

Push the lever towards yourself in order to wash the windshield. The windshield wiper will move thrice. The windshield wiper will keep working while you hold the lever.

The water spraying will be started for 0.7 seconds after pushing the lever, then the wipers will start their cycle. But the wipers will stop when after three cycles when you release the lever. The fourth cycle to clean the windshield will be started after three seconds from wipers stop.*



CAUTION

In freezing climate please be ensure that the wipers are not frozen. (risk of wipers engine overheat)
Check the wipers status. In case of wipers low performance, you'd better to replace them. (approximately once a year)

Keep the vehicle windshield clean. If you turn off the engine before turning off the wipers (0 status), the wipers will stop immediately in their current position. In this condition, you should changes the wipers to 0 status, then the wipers will move to their normal position.

Make sure that the wipers are on 0 status, before you take action to open the hood. (risk of injury)

*If equipped

Reverse Gear

Warning system:

This system gives the Driver the possibility of an easy, confident, precise and ensured parking, in all conditions and situations.

Details of operation:

Reverse gear sensors are installed in the rear bumpers of the car and will be activated only when the engine is in reverse gear situation and warns the Driver of obstructions by sounding the whistle. The less is the distance between the car and the obstruction, the more is the sensitivity of the system and more number of whistles will be heard in a defined period so that the Driver comes to know out the situation of his car in relation to the obstruction.

-Specification of the system:

This system in PEUGEOT PARS, consists of four eye sensors (in some models two eye sensors) installed in the rear bumpers of the car which inform the driver about the obstruction within following distances:

- Distance between 92 to 138 centimeters: Three alarms in two seconds.
- Distance between 46 to 92 centimeters: Three alarms in one second.
- Distance between 05 to 46 centimeters: Continuous alarms.

-Trouble shooting of the system:

In case of malfunctioning or disconnection of any sensors, this system sounds a different alarm to 3 mentioned above alarms. To rectify the problem take the car to an authorized workshop.



WARNINGS

-This system is meant to help the Driver to distinguish the objects (from behind during parking), within 150 centimeters with speed of less than 5 kilometers per hour. It also has limitations regarding estimation of detectable distance and the obstructions, therefore Driver's precaution, in cases of having undetectable obstructions, is necessary.

-This system uses the sound signals to help facilitation of parking and obtaining the approximate distance to the obstruction, during movements with reverse gear.

Therefore existence of this system, should never cause sudden movement and careless driving back side. (Reverse gear).

-The Driver should always take precautions about sudden cases that might happen during usage of reverse gear. Mobile obstructions (Kids, trolleys, bicycles, pets, ...) or short and very tin obstructions (Road blocks, tin guard rails, ...)

- In case the sensors being covered with mud or any other obstructions, this system will face disconnection or malfunction problems.

It is recommended that the surface of the sensors always kept clean.

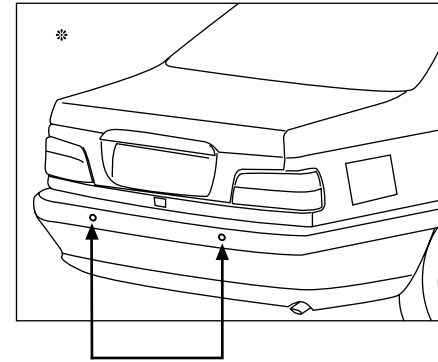

Rear gear sensors

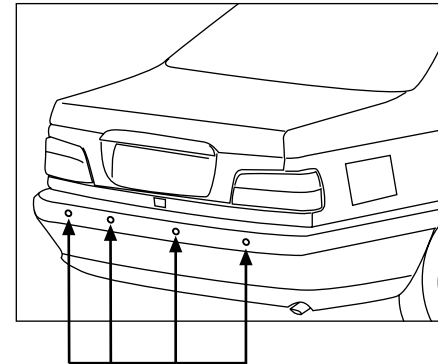

Rear gear sensors

*If your vehicle is equipped

HANDS FREE MOBILE

2

Hands free mobile with the Bluetooth technology

Avoid talking with phone for your safety as far as possible.

Bluetooth is used in short distance.

It can only connected to the devices supporting the Bluetooth facilities.

After connection you can control your mobile via the device.

pairing or mobile coordination with hands free system:

To connect with mobile phone use this function.

1- Turn on the device.

2- Hold the button  for a few seconds to activate bluetooth device sign of bluetooth will appears and blinking on the top of display screen.

3- Turn on your mobile bluetooth and keep your mobile in a distance less than 3 m, and search for bluetooth devices.

4- Select the name "IKCO" from the list .in case of need enter the code of "1234". Connection will be established automatically.

In case of observing the two options of "connect" or "disconnect" in some mobile devices, please select the connect option.some devices don't need to enter the code. after

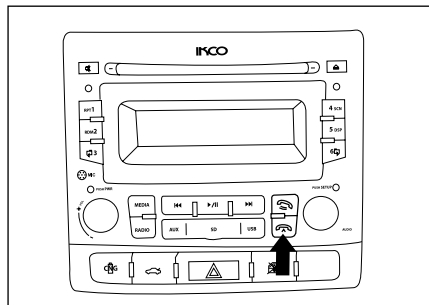

connection of your mobile set with that of vehicle device the sign of bluetooth stops blinking and stays in stationary position on display screen.

How to disconnect mobile set with the device

If you wish to disconnect the mobile set from the bluetooth ;just press the button  and hold it.

Receiving a call

1- After connecting with the bluetooth and receiving a call ,device will go on BT mode and the received no. will be shown on display screen .

2- If you wish to reject the call ;just press the button  . Display screen will show the "REJCALL"

3- To receive a call press the button  Display screen will show the "TALKING " after connection .

4- After conversation and to disconnect the call ,press the button  . Diplsay screen will show the " END CALL".

Call Transfer

To transfer the call from the device to mobile while you're talking ;just press the button  . Dislay screen will show "PRIVATE". To transfer the call from the mobile to the device press the same button again.

Audio Bluetooth (BT AUDIO)

1- To listen the music via the mobile set and controlling it by the device press the button "MEDIA " frequently so that you can select the option of " BT AUDIO "

2- To make a pause or play the music again ; just press the button /||

3- Press the button  << >> To change the track.

4- Press the button  << >> to review or front the music tracks .

Audio equipment buttons installed on the steering wheel *

1- (MUTE) The sound will be connected and disconnected by pressing of this button.

2- (- +) To increase and decrease the volume.

3- (↕) a) selecting the previous and next track (USB/CD)

b) Automatic search for the stations (in radio mode)

4- (MODE) To enter to the menus of

RADIO > CD PLAYER > USB > AUX > BT

5- (☎) response to the received call (in case of receiving any call) by pressing the button for 2 seconds, pairing is possible.

6- (📶) disconnection of the device with mobile phone.

To disconnect the Bluetooth connection between your mobile phone and radio, press and hold the button.

7- (🔒) Private conversation.

8 - (📢) To use the horn, press steering wheel cover nearly every one of the foundations of the command button.

Note :

The background of key light are white and it gets on by turning the SIDE LAMP on.

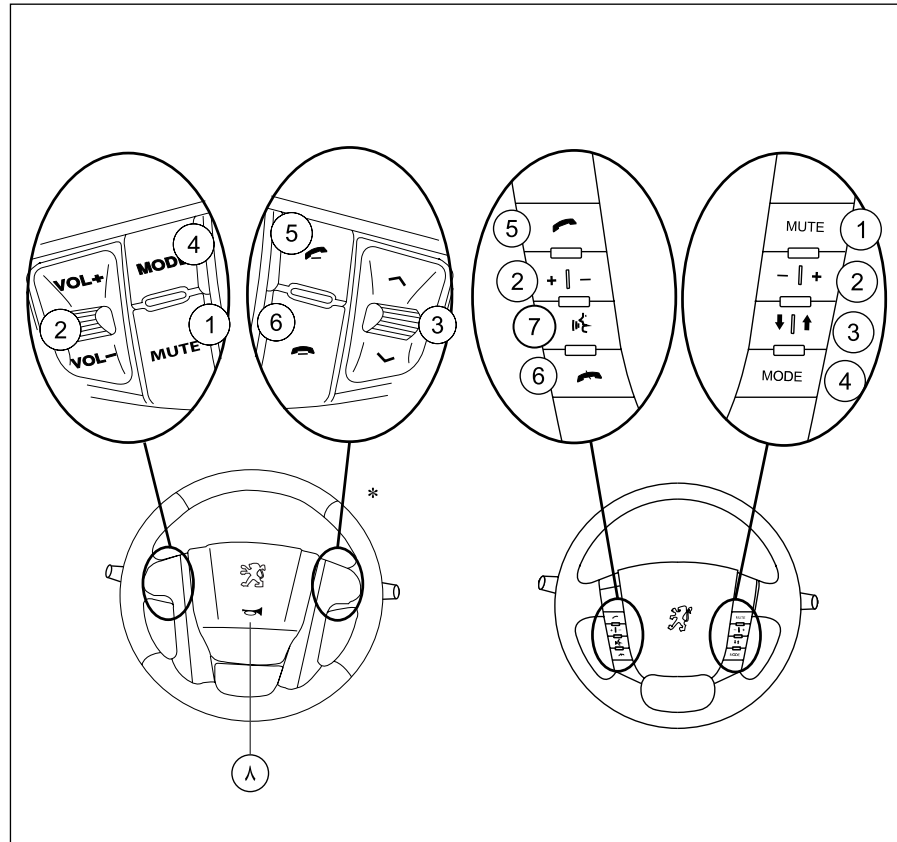

*If equipped

AUDIO SYSTEM

2

Audio System Control Panel

1- Short Pressing: Turning on.

- Prolonged pressing more than 2 seconds: Turning off.

- Volume Turning: Sound adjustment.

2- Radio Mode:

- Short Pressing: Memory No. 3

- Prolonged Pressing: Recording of current frequency in memory No. 3

CD/USB/SD mode

- Short Pressing: Selection of the previous folder in MP3/WMA files.

- Prolonged Pressing: Selection of 10 former files in current folder.

3- Radio Mode:

- Short Pressing: Memory No. 2

- Prolonged Pressing: Recording of current frequency in memory No. 2.

CD/USB/SD mode

- Random playing of melodies.

4- Radio Mode:

- Short Pressing: Memory No. 1

- Prolonged Pressing: Recording of current frequency in memory No. 1

CD/USB/SD mode

- Repeating of the file/playing folder.

5-Disconnection of Sound output (MUTE)

6- Disc Input

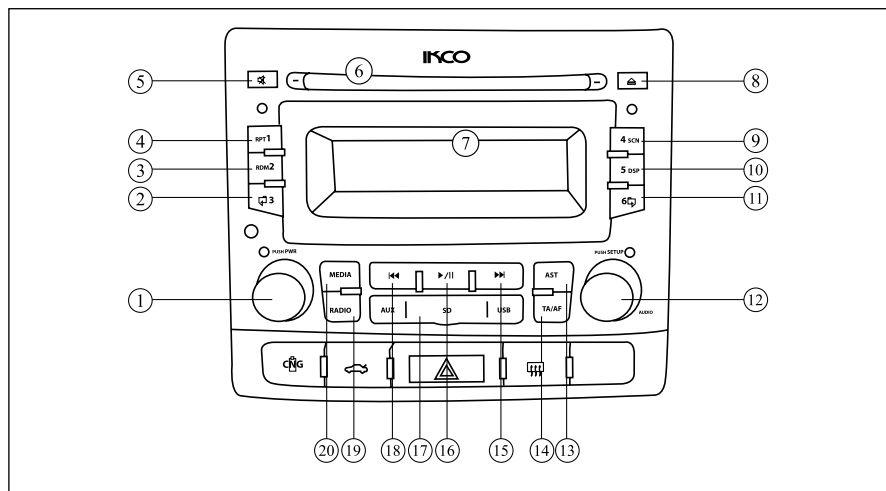

7- Monitor

- Prolonged Pressing: Recording of current frequency in memory No. 5

8- Disc eject button

CD/USB/SD mode

- Introducing the audio files (playing 10 seconds).

- Displaying of the audio file information with MP3/WMA Format.

9- Radio Mode:

- Short Pressing: Memory No. 4

- Prolonged Pressing: Recording of current frequency in memory No. 4

CD/USB/SD mode

- Introducing of the audio files (10 seconds playing).

11- Radio Mode:

- Short Pressing: Memory No. 6

- Prolonged Press: Recording of current frequency in memory No. 6

10- Radio Mode:

- Short Pressing: Memory No. 5

CD/USB/SD mode

- Short Pressing: Selection of the next folder in

MP3/WMA files.

- Prolonged Pressing: Selection of 10 recent files in current folder.

12- Short Pressing: Selection of the audio Adjustments.

- Prolonged Pressing: Entering to the system adjustments.

- Turning: Radio Mode: Frequency adjustment manually.

CD/USB/SD mode: Selection of the previous/next melody.

13- Short Pressing: Automatic searching & saving of the radio stations.

- Prolonged Pressing: The button introduces the radio stations t(10 seconds playing)

14- Short Pressing: Activation/Deactivation of TA.

- Prolonged Pressing: Activation/Deactivation of AF.

15- Radio Mode:

Short Pressing: Automatic searching of the radio stations in order to increase the frequency.

CD/USB/SD mode

- Short Pressing: Selection of the next melody.

- Prolonged Pressing: Rapid forwarding of the melody while it's playing.

16- Short Pressing: Play/Stop the melody.

- Prolonged Pressing: Selection of the first track.

17- USB/SD/AUX Cover

18- Radio Mode:

Short Pressing: Automatic searching of the radio stations in order to decrease the frequency.

CD/USB/SD mode

- Short Pressing: Selection of the previous melody.

- Prolonged Pressing: Rapid backward of the melody while it's playing.

19- Replacing of the Radio Band

20- Selection of the player (CD/USB/AUX IN)

AUDIO SYSTEM

2

PRECAUTIONS

Make sure of the speaker negative terminal to be connected to the connector negative terminal. Avoid connecting the speaker positive and negative terminal to each other or to the device body.

Make sure of the fuse ampere, if it is required to be replaced. Using the higher ampere will cause the device to be seriously damaged.

Make sure of the tiny parts and things not to be entered into the device. In the case of entering, it will cause malfunction of the device, electric shock or laser radiation. The device sound should be kept to such an extent that external sounds especially the warning alarms (The other vehicles horn sound etc) to be heard.

Stop the car, before doing any complex action on the device.

Do not adjust or open the device ,in case of any problem. Refer to the Iran Khodro Authorized Dealers to solve any probable defect.

CD UTILIZATION POINTS

- Do not use dusty /damaged CD; it will cause the sound noises.
 - Do not touch the CDs surface but the edge to carry them.
 - Avoid sticking any labels on both sides of the CDs.
 - Avoid putting the CD against direct sunlight and heat consumedly.
 - To clean the CD, use soft tissues rubbing it from the CD center towards the edges.
 - To clean the dirty panel or display, use silky tissue and natural cleanser.
- Using of coarse tissue and chemical substances like alcohol will cause the surface of it to be damaged and scratched
- The device may not be able to display the labeled CDs. So, before inserting the CD, remove the label.
 - The 3-inch (8cm) CDs are not useable for the device. Never use rugged and 3-inch Cds instead in 8cm to 12 cm convertor .Otherwise, the device will not be able to eject it.
 - Dust existing inside of the CD holding frame will cause the CD to be damaged and scratched. So, clean the CD frame in an definite intervals.

ANTI-THEFT SYSTEM OF THE AUDIO SYSTEM

How to enter the password

For more security, your device is equipped with 4 digit code. In case of electrical disconnection of the device for any reason and, after reconnecting and turning on the device, the monitor displays the phrase "PWD****". To turn on the device, the correct 4 digit code should be entered through the buttons 1 to 4 on the panel.

To enter the 1st No. from the left side of (****PWD), press the radio button No. 1 frequently to display the correct number. (For example: For selection the No.5, press the button No. 1, 5 times. After correct adjusting of the first number, to enter the 2nd number of (****PWD), press the radio button No. 2 frequently to display the correct number. To enter 3rd and 4th Nos. press the same buttons as previous ones. To confirm the password, press the SETUP/AUDIO button. In case of the correct password, the device turns on; otherwise, displays (Error). After short seconds, the system requests the password again on which entering the correct password, the device is turned on. If the incorrect password is entered for six times, ERR20 is displayed on panel which is indicating the blockage of the system. Here, you should refer to the Iran Khodre authorized dealers.

Note: The default password by Iran Khodro is 1111.

CHANGING THE PASSWORD

Whereas, the default password before changing is considered 1111 by Iran Khodro, it is better changing it for more security. To change the password, hold the "RADIO" and "RPT/1 buttons for 2 seconds simultaneously. The "****PWD" message demands the adjusted password. In case of entering the correct 4 digit password, the "****PWD" message is displayed to enter the new 4 digit password. Enter the new code and press the SETUP/AUDIO button. Now, the "****PWD" message demands again the new 4 digit password for comparing. Select the previous new 4 digit code and press the SETUP/AUDIO volume button. If the entered password are matched, the "****PWD" message is displayed and means that the password has been changed. While the 2 entered password is not the same, the "SETFAIL" message is displayed and it means there is an error in changing the password. Now, all the changing process should be repeated again.

AUDIO SYSTEM

GENERAL INSTRUCTION

On/Off the device

- To turn on the device, press the PWR button.
- To turn off the device, press and hold the same key.

2

POINT:

When the vehicle is not running, by pressing the "PWR" button or inserting the CD the device could be turned on for 30 minutes. Pay attention the device is not turned on by entering USB/SD/AUX. After 30 minutes the device turns off and by pressing the "PWR" button you can turn on the device again.

MEDIA button

Press the "MEDIA" button, to switch the disc (when the disc is situated in the device), USB (when the USB is connected to the device), SD card (when the card is inside the device) and AUX IN (when AUX IN socket is connected).

MUTE button

While the device is on, press the key for a moment. The mute mode is activated and output sound is disconnected. To exit, press again the same key.

VOLUME ADJUSTMENT

Turn the volume to adjust the sound . Turn the volume clock wise (right) to increase, and turn it counter clock wise (left) to decrease the sound level.

THE SOUND QUALITY ADJUSTMENT

To access the following, press AUDIO repeatedly:

- EQ (EQ OFF, POP, CLASSIC, ROCK, JAZZ)
 - BASS (-7, +7)
 - TREBLE (-7, +7)
 - BALANCE (7--, -0-, 7--)
 - FADER (7_, -0-, _7_)
 - LOUD (ON, OFF)
-

To adjust each of these, turn the AUDIO volume.

While adjusting, there is no change for more than 5 seconds, the device automatically returns to its last mode. BASS and TREBLE are just adjustable in EQ OFF mode.

HOW TO USE THE RADIO

The band changing

To select the radio, press the same key.

By frequent pressing of the "RADIO" button when playing, you could choose one of the bands with following sequence:



AUTOMATIC SEARCHING OF THE RADIO STATIONS

By pressing the ►► and ◀◀ buttons, you could activate the automatic searching system to increase/decrease the radio frequencies. After receiving the desired radio station, you could save the station in one of the memories from 1- 6.

To save the desired station, press and hold the related number for 2 seconds.

THE RADIO STATIONS MANUAL SEARCHING

To increase the radio frequency manually, turn the AUDIO key clock wise and to decrease counter clock wise.

AUTOMATIC SAVING OF THE RADIO STATIONS

To select automatically 6 powerful radio stations and saving them instead of the present stations, press the AST key. The present stations are replaced instead of the previous saved ones

The received stations in FM band are saved in memories 1- 6 of FMAS band and in AM band are saved in memories 1- 6 of AMAS band.

Tip: By using this order, the previous saved memories are erased and the new stations are replaced instead of them. By pressing the AST key for more than 2 seconds each accessible radio station is played for 10 seconds and then shifts to the next station.

SAVING THE STATION ON THE MEMORY

To save the new radio stations on the memory of CD player, you should hold the number of desired memory for 2 seconds after receiving the radio station. After hearing the beep sound , current frequency is saved on the memory.

RDS DATA

Disposal services through RDS system (Radio Data System) are as follow:

PS PROGRAM SERVICE NAME)

This service displays the current station name on the panel in the case of forwarding by the forwarder.

ALARM MESSAGES (PTY ALARM)

In the case of sender the urgent warnings by the sender, the messages will be displayed on the panel.

TA (TRAFFIC ANNOUNCEMENTS)

By this the driver will receive the important traffic announcement.

By short pressing on TA/AF key, TA service is activated or deactivated.

AF (ALTERNATIVE FREQUENCY)

By using this service the device automatically searches and receives the more power frequency of the current radio station. By pressing TA/AF key for more than 2 seconds, AF service is activated or deactivated.

Point: The abovementioned services should be forwarded by the central forwarder. At present, PS is the only active service in Iran.

HOW TO USE CD/USB/SD/AUX

Inserting the disc

While inserting, the disc labeled surface should be upwards. Insert the disc such an extent that the internal mechanism of the CD player automatically pull it inside. The first file on the disc is automatically played.

Note: The device has been designed just for playing the 5 inch (12 cm) standard discs. Avoid using 3 inch (8 cm) discs. Inserting of

such CDs by using/not using of the adaptor will damage the device or the disc.

PAUSE BUTTON

In CD/USB/SD switch, if press the button ►/|| for a moment pause switch is activated and the audio file that is playing will be stopped. Repressing the button, the system comes back to its normal playing. To play the first file of the disc, hold the button ►/|| for 2 seconds.



AUDIO SYSTEM

2

SCN BUTTON

While playing CD/USB/SD, press “4SCN” to present exiting files. By pressing of this key each file will be played for 10 seconds. By repressing of the key, the system comes back to the normal position of playing.

RPT BUTTON

While playing CD/USB/SD switch, to repeat the playing file press “RPT1” button to select the “RPTFILE” mode. To repeat all of the files inside the current folder repress this key to select the “RPT DIR” mode. The playing is continued so long as the “RPT1” key is pressed to choose the “RPTOFF” mode.

RDM BUTTON

While the playing CD/USB/SD switch, press “RDM2” button to select the random playing of the files. To stop random playing mode and coming back to the normal position, repress the “RDM2” button.

SEARCHING OF THE FILE & FOLDER

Disc Playing Mode (TRACK/MP3):

To select previous/next file, press ►► and ◀◀ keys. In case of pressing and holding the above keys, you could play the file forwards/backwards.

MP3 playing file

To select previous/next folder, press ◀ 3 and 6 ▶ keys. In case of pressing and holding the above buttons, you could choose 10 previous/next file.

EJECT BUTTON

To eject the disc, press button.

THE MONITOR DATA

While the files MP3 and WMA are playing, by pressing of the button “5DSP”, the panel displays the data related to the playing file as the following: FILE, FOLDER.

While the file/folder name is displaying, by repressing of the button, the panel displays the data related to the ID3 label like a movable tape which consists of: TITLE, ARTIST AND ALBUM. Then the device comes back to the normal position.

PLAYING OF THE SD FILES

Open the USB/SD/AUX port cover. Insert SD memory card .After several seconds, the device automatically plays music.

FLASH MEMORY

Open the USB/SD/AUX port cover. Connect the flash memory to the USB connector. The device automatically plays the saved music in Flash Memory.

POINTS ABOUT MP3 FILES

- The device could be able to display just English characters of “- , +, A, Z, 0-9”.
- Maximum, 16 characters is used to display the name of an album or file.
- In case of recording MP3 files on the disc make sure the saving format is the data type not audio.
- In order to enjoy the best quality sound, it is recommended the files switched to MP3 files with sampling frequency of KHZ 44.1.

POINTS ABOUT USB/SD

- The files with *WMA, *MP3, *Mp3 are readable.
- Fat 16/Fat 32 is readable.
- The device maximum readable memory is 32GB.
- Sampling frequency 8KHZ- 48KHZ
- Bit rate 8-320kbps

Points: While the playing in USB mode does not cut off the USB suddenly. This causes the USB to be damaged. First change the source and then cut off the USB. Or turn off the device and then cut off the USB.

THE SOUND AUXILIARY INPUT

Open the USB/SD/AUX port cover. Connect the sound auxiliary input socket. The device automatically plays AUX IN socket input file.

THE SYSTEM ADJUSTMENTS

By pressing of the "AUDIO" volume for more than 2 seconds you will enter the system adjustments as the following: Then, by each pressing of this button there is one of the following:

S-VOL->TIME->TIME AD->RDS->REG-
->NEWS->EON->L-OUT->LCD

To change each of the above adjustments turn the "AUDIO" volume. To exit the adjustments menu press the "AUDIO" volume for more than 2 seconds.

Point:

The CD player is automatically exited from the system adjustments menu if there is no action after 5 seconds.

S-VOL

By this switch you could adjust the first sound volume such an extent that not to exceed the fixed volume when the device turns on. The volume is adjustable from 5 to 25.

- If the sound volume is less than the above before the device turns off, the sound volume will be adjusted the last one when the device turns on again.
- If the sound volume is more than the above before the device turns off, the sound volume will be automatically like the adjusted one when the device turns on again.
- If the sound volume is less than 5 before the device turns off, the sound volume will be adjusted 5 when the device turns on again.

CLOCK (RDS/MAN) ADJUSTMENT

In case of selection the "RDS" from "RDS clock" and "MAN" it is possible to adjust the clock manually.

(TIME)DISPLAY ADJUSTMENT

This switch could be adjusted as one of the following: 12/24 hour.

AUDIO SYSTEM

RDS (ON/OFF) ADJUSTMENT

You could activate or deactivate RDS (Radio Data System).

2

REG (ON/AUTO/OFF) ADJUSTMENT

In case of selection of ON switch the regional stations is received. In case of selection of AUTO switch the power stations is searched. In case of selection of OFF switch the first radio station received by the system regardless input signal power is played. The REG switch is just adjustable in RDS ON mode.

NEWS (ON/OFF) ADJUSTMENT

The NEWS switch could be activated or deactivated. The NEWS switch is just adjustable in RDS ON mode.

EON (DX/LO) ADJUSTMENT

In case of selection of LO switch the power stations is just received. In selection of DX switch the first radio station received by the system regardless input signal power is played. The REG switch is just adjustable in RDS ON mode.

L-OUT (ON/OFF) ADJUSTMENT

You could activate/deactivate the Line-out output.

LCD (0 ~7) ADJUSTMENT

By selecting of this switch you could change the LCD lighting intensity.

MAINTENANCE

- Avoid any liquids inside the device. If so, dry it rapidly. Because the liquids will cause malfunction or electrical shock.
- Keep the device out of dust and pollution. These will cause external disadvantages.
- Precaution to carry the device. Strike or falling down could likely cause damages.
- To clean the dirty panel/monitor use silk tissue and natural substances.

ELECTRIC CONNECTORS

Diagram of bases of the CD player connector as follow:

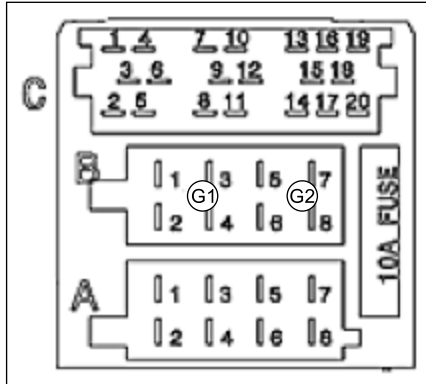

Connector A		Connector C	
Position	Performance	Position	Performance
A1	-	C1	LINE OUT LEFT OUTPUT
A2	-	C2	LINE OUT RIGHT OUTPUT
A3	INTENSITY CONTROL INPUT	C3	LINE OUT EARTH
A4	BATTERY	C4	-
A5	ANTENA CONTROL (ANT)	C5	-
A6	LIGHTING (ILL)	C6	Amplifier steering output
A7	ACC VOLTAGE	C7	-
A8	EARTH	C8	Control Input on the Steering
	CONNECTOR B	C9	-
		C10	-
Position	Performance	C11	Control circuit earth on the steering
B1	REAR RIGHT SPEAKER +	C12	-
B2	REAR RIGHT SPEAKER -	C13	-
B3	FRONT RIGHT SPEAKER +	C14	-
B4	FRONT RIGHT SPEAKER -	C15	-
B5	FRONT LEFT SPEAKER +	C16	-
B6	FRONT LEFT SPEAKER -	C17	-
B7	REAR LEFT SPEAKER +	C18	-
B8	REAR LEFT SPEAKER -	C19	-
		C20	-

AUDIO SYSTEM

DEFECT FINDER

The following controlled list could help you to solve some problems that may be occurred at the time of using the device. Before using, control all the connectors and the manual. Do never use the device at unusual conditions such as when the device is mute, at the time of fume or singe that may cause fire or electric shock. Here, you should turn it off immediately and contact to after sales agencies (Refer to the guarantee manual).

2

SOLUTION	DEFECT	THE PROBLEM
On the switch	The switch off	The device is not turned on
Control the cables connection	Not correct connection of the cables	
Change the fuse with the same fuse	The fuse is burned	
Eject the previous disc	There is another disc inside the device	The disc is not inserted
Insert the disc in correct position	The disc is in reverse position	The disc is not readable
Clean the disc or use another disc	The disc is dirty or damaged	
Wait the cabin temperature decreases	High temperature inside the vehicle	
Check the disc format with the formats mentioned in the manual	The file format is not readable	
Control the sound volume or deactivate the mute	Minimum adjusting the sound volume or Mute mode	Mute
Control the cables connection	Incorrect connection of the cables	
Install the device firmly with side parts	The device installation place is not firm	While running the vehicle, vibration causes the sound cut on/off
Install the antenna correctly		It does not receive the radio stations or with low quality
Open the antenna completely or in case of broking change to a new one	Incorrect installation of the antenna	
Connect the device battery power input to the vehicle battery	The antenna is not completely opened or broken	The memory saved stations have been erased
	Incorrect connection of the battery cable	

Heating and Ventilation

The heating and ventilation system provides fresh or heated air to the interior of the car from the intake grille in front of the windshield.

NOTE: Keep the air grille in the rear window shelf uncovered to enable air flow through the whole of the interior.

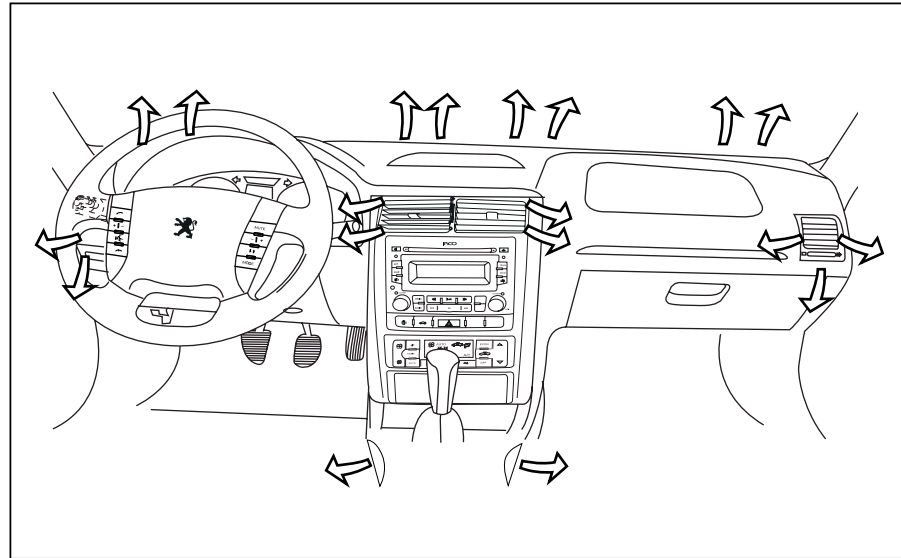

2

**WARNING**

Do not open the coolant fluid circuit.
This fluid is dangerous to the eyes and skin.

**CAUTION**

Heating and Air Conditioning System

- To prevent the probable damage, use the distilled water in radiator.
- To help maintain optimum performance and durability of your air conditioner (even in winter), it needs to be operated at least once for about 10 minutes each 15 days .
- It is recommended the A/C system should be turned off before the engine. Charging of A/C gas will be harmful to your A/C system.(except R-134a gas which is compatible with environment and non-destructive of Ozone layer)

HEATING / VENTILATION

The following procedures will enable you to gain maximum benefit from the heating and ventilation system.

2

Maximizing Heating System

- Set all air vents **towards foot wells**.
- Slide temperature control lever to the red section.
- Slide blower speed control level to the right as needed.

Maximizing Cooling and Air Flow System

- Set the airflow-adjusting key on "**face ward**" position and be sure that the grilles are open.
- Slide temperature control lever to the blue section.
- Slide blower speed control lever to the right as needed.
- Turn on air conditioning.

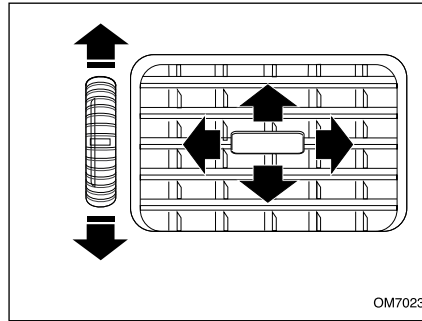

Center and Side Vents

Rotate the thumbwheel down to close the grill, and rotate up to open the grille. Move the grille button to sides, up or down to adjust air flow.

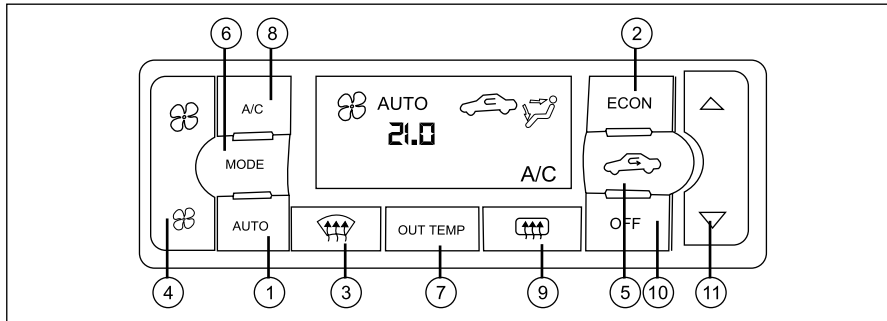

Automatic ventilation system

Turn on the engine and activate the keys.

1- Automatic functioning mode (Auto) : Cooling or heating along with demisting (Automatic)

This mode can be used through entire year and the temperature can be controlled according to the passenger wish.

- Setting the fan speed current are automatically done.

1 - Press the automatic (AUTO) button.



CAUTION

- Cooler functions only when the engine is on .
- Don't keep the children , old people and animals alone in the vehicle.
- The temperature goes on fast in n the hot and sunny days. The severe heat can harm or even cause to the death of the passengers.
- The circulation mode should not be used for a long time ;otherwise it causes the suffocation and the glasses to be vapory .
- Avoid switching the heating and ventilation system buttons while driving to for complete attention to driving .

2. Set the desired temperature. (Red arrows temperature increase and Blue arrows temperature decrease)

- Adjust the normal temperature on 25 ° C .
- The temperature of the cabin will be automatically fixed. Air vents and fan speed are also controlled automatically.

2- Heater (ECON)

use ECON mode in winter and in cooler silent mode (minimum fuel consumption).

1. Press the ECON button. Switch to the desired temperature.

ECON sign on the screen will be shown.

-The temperature inside the cabin will be automatically kept constant.

Air vents and fan speed will be also controlled automatically.

HEATING AND AUTOMATIC VENTILATION

2

- Do not set the temperature lower than the temperature outside, otherwise, the system may not work properly

- If the windows get vapory ,it's not recommended.



3- demisting, defrost the windshield

1- Press the windshield air valves  (DEF) button and turn it on . indicator on the LCD (display) will light on .

2- Switch to the desired temperature (select the high temperature to accelerate the demisting).

- Soon after the windshield gets cleared of vapor and ice, press the automatic button (AUTO) so that the system returns to the automatic mode.



Demisting and rear window defrosting mode

Press the button  (the symbol will appear on the screen) rear glass will be activated by electric heating elements for 12 minutes and at the end it turns off automatically.





4- Non-automatic function of fan speed control

* Press the fan control button to get fans as usual (Non-automatic) control. Press the AUTO button to control the fan speed automatically .

- Press the AUTO button so that the system goes on to automatic mode.



5-Air flow control button

press the cabin air control button. The air circulation is adjustable to the fresh air (AIR FRESH)  or flow cabin  according to the passenger selection. Press the AUTO button to switch the system to automatic mode. When the temperature in the cabin is high. to cool the cabin faster in AUTO mode select the air flow of cabin key.



6- Control of outlet vent

By pressing the MODE button control standard (non-automatic) vents (word MANUAL will be displayed) conducts the air into 5 cases



Exhaust air from the front (face) blown.



Exhaust air from the front (face)

and the leg is blown.



The main stream of air is blown through the outlet side of the legs.



The air is blown beneath of the glass and foot.



The air is blown out of the glass.



7-Outside temperature (OUT TEMP button)

press the outside air temperature OUT TEMP button. The weather outside is visible on screen about 5 seconds .



8- Air Condition Service (Cooler)

Cooler system in your car has been with a cooling gas which is meeting the environment principle rules .

"The cooling gas will not harm the ozone layer around the earth," though it may have little influence on the Earth's warmth. Special tools are required to charge and lubrication at the time of charging and service.

Using inappropriate oil or gas will harm air conditioning system. Authorized representative is allowed to service or repair the air conditioners.



9- Rear window heater

It's used to demisting and defrosting of rear window and side mirrors



10-Power off

Automatic air conditioning system gets off by this key off.



11- Temperature regulation

Press the temperature setting button to get the temperature controlled (non-automatic) If you press the AUTO button, the temperature is automatically controlled.

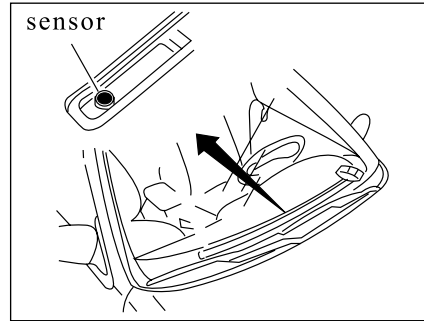

Automatic air condition system sensor

The system is equipped with sensors that controls the ventilation automatically.

1. The light intensity sensor

- Location: Beneath of the windshield on the dashboard

Note: Avoid placing objects on the sensor.

2-Sensor for inside the cabin:

Location: under the steering wheel frame

-Don't create a barrier for the air flow to the sensor .

3. Defrosting Sensor

Location: Inside the HVAC ventilation system.

4. The outside temperature sensor

- Location: on the front bumper

5. Sensor for temperature of Engine water.

Note :

In the winter, when the engine and the outside temperature is low; ventilation system fan will not work for 3 minutes until the engine temperature reaches to the desired limitation.

Automatic ventilation system is equipped with an air filter to prevent the entry of contaminated air and dust and smoke. Note to replace it according to the manual on its own proper time.

If the fan speed is poor or bad odor or incomplete demisting is observed; replace the filter.

Press the OFF button to turn off the ventilation system and then turn off the engine. prevent the blocking of the windshield valves.

Avoid placing the objects on light intensity sensor in the middle of the dashboard beneath the windshield; and the outside temperature sensor on front bumper.



WARNING

- In cases where the car has an air conditioning system, note that sunlight sensors and temperature sensors inside the cabin will not be blocked because blockage of these sensors can lead to inappropriate performance of the ventilation system.*
- When you're driving uphill, it is necessary to turn off the air conditioning system in order to prevent excessive pressure on the engine.
- The presence of snow, ice, etc. in the way of entering the air into the cabin will cause improper performance of the air conditioning system of the . Therefore, in order to ventilate the interior of the cabin, ensure that the intake air is not obstructed into the cabin.
- Permanent use of the air conditioning system during air circulation in winter or during rain can cause windshield fogging and obstruction of the driver's vision and the accident. So, in this situation, use the fresh air intake mode to the cabin.
- In order to ensure the correct operation of the vehicle air conditioning system, checking the Air conditioning pipes are essential to ensure the lack of leakage.

In wet climates, the formation of steam on the glass is a natural occurrence. Therefore, turn on the vehicle air conditioning system, to get inside of the vehicle air dehumidified.

in warm seasons and when the vehicle is exposed to sunlight for a long time, first open the glass and let the warm air get out of the vehicle and then turn on the air conditioning system.

This is caused to reduce fuel consumption and improves air quality of the cabin.



WARNING

- Avoid sleeping in the vehicle when the air conditioning system (cooler or heater) is on, as , this may result in increase in carbon dioxide in the cabin or an increase in body temperature causing serious injury and even death.
- Long-term use of the air conditioning system in air circulation condition can cause the reduction of the air inside the vehicle and cause the passengers to feel sleepy that can result in an accident.

* If installed in your car

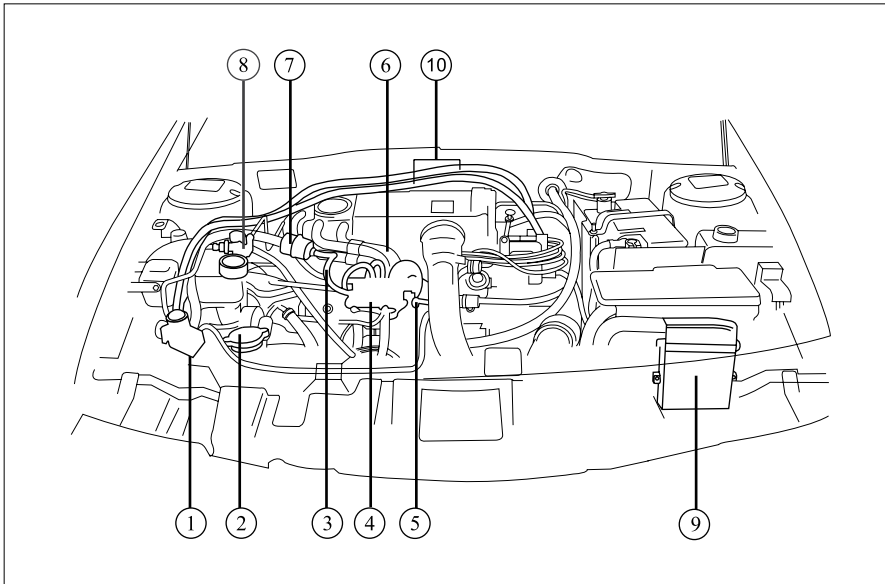

CNG System: Engine Compartment Overview *

1. Regulator: Reduces the gas pressure from a maximum of 200 bar to 2 bar.

2. Hose (transferring gas to gas filter): Transfers the reduced pressure gas from the regulator to the fuel filter*.

3. Hose (transferring gas to fuel rail): Transfers the reduced pressure gas from the regulator to the fuel rail.

4. Fuel Rail: Gas entering the manifold passes through the fuel rail, and enters the manifold when the gas injectors open in the indicated times.

5. PT(Pressure- Temperature) Sensor: This sensor is mounted on the fuel rail and transfer the data to the ECU*.

6. Gas Hoses (Fuel Rail to Injector Nozzel): These flexible tubes allow gas to enter the intake manifold*.

7. Gas Filter: A device for screening the gasoline to remove the impurities from the fuel rail*.

8- Service manual Tap :

The input gas track to engine compartment is opened and closed through this tap.

9. Electrical Control Unit (ECU): Adjusts the moment and time length of injector sprinkling and the timing of sparking in different engine conditions.

10. Input / Output Hot Water Hoses (Regulator): Transfers the heater water to the regulator to warm up and to prevent the regulator from freezing when operating on gas mode.

CNG FUEL SYSTEM

2

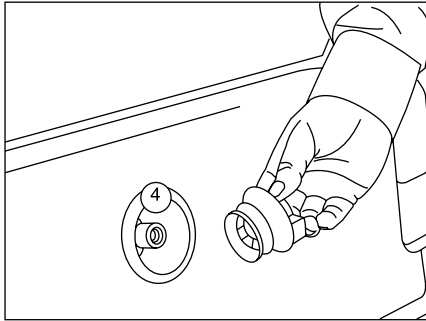

Introducing CNG Fuel system placed in trunk lid*

1. Tank (Tanks): CNG is contained by 200 bar pressure at highest.

2. Tank Valve: Limits and opens the gas passage at the end of the tank, and includes equipment which evacuate the gas tank when gas pressure and temperature exceeds the standard limit. If the pipes are cut, it limits the gas escape from the tank.

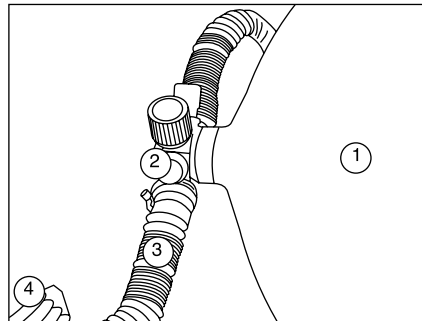

3. Pipes & Gas Ventilation System:

It transfers the High Tension Pipe of CNG to the regulator through outlet of reservoir valve with the pressure of 200 bar.

Ventilation system transfer the gas outside the trunk if any leakages happen in connections.

4. Filler: It is a part installed on the automobile for fueling the gas tank and it is connected to the fuel nozzle in the gas station.



CAUTION

- Avoid keeping any object on the tank beside the tap or on the high tension pipe.
- Avoid keeping any sharp objects beside the tank, which cause the damage to the CNG equipment in the boots.
- ensure that tank tap is closed before ant repair process.

*If equipped

Anti-Lock Braking System (ABS)

Anti-lock braking system is one of the car new and control systems preventing the wheels from locking on slippery roads, or by intense braking on dry roads. Therefore, it reduces the brake distance, steer ability, improves stability, and increases car safety in general.

When using a car equipped with anti lock brake system always consider the following points:

–Since the anti lock braking system is only for balancing the brake force, therefore when braking sufficiently press the brake pedal.

– Feeling brake pedal vibrations under the foot while braking over unstable roads or sudden braking is normal and caused by the operation of the anti-lock braking system.

In this situation press sufficiently the brake pedal with confidence making sure of proper function of braking system.

–Hearing beating wise noise from front and rear wheels when braking over slippery roads or sudden braking is normal and due to the correct operation of the anti-lock braking system.

–Anti-lock braking system is equipped with an automatic defect finding system that will light the anti-lock braking system warning indicator, on displaying instrument panel in case of a problem.

–When the car is turned on, the anti-lock braking system warning indicator on displaying instrument panel gets on and will turn off after a few seconds. If the warning indicator does not light when the car is turned on or remains lit, it's a sign of problem in the anti-lock braking system. In this situation the car should be directed to an authorized workshop for diagnosis by computerized system of defect finder.

It's good to bring to your notice in case of damage or presence of any problem in anti-lock braking system, your vehicle has just the capability of an ordinary braking system.

–If the handbrake is completely released and both the handbrake indicator and anti-lock braking system warning indicator are lit, on displaying instrument panel, stop the car with precaution and contact a nearest authorized workshop.

The brake dragging distance will be more while you're driving on sloppy surfaces. Make sure of proper functioning of the brake after washing the vehicle or while you're passing from the puddles.



CAUTION

-Operation of ABS brake system is independent of pressure imposed to the brake pedal. Therefore in emergency situations, it is recommended to use a strong and continuous pressure on the brake pedal. It is not necessary to apply pressures one after another. (Filling or pressurizing the brake pump).

-For trouble shooting and servicing of Anti Brake System, definitely approach authorized workshops and strictly avoid attending in sundry places.



WARNINGS

-This system shall never be considered as a factor to encourage sudden acceleration and driving with more speed.

Therefore it can not substitute the accuracy, precautions and responsibilities during driving .

This operation is an auxiliary aid which during driving in emergency situations, controls it's behavior proportional to the existing conditions of driving.

-Seriously Avoid driving with unpermitted speed in passage ways, specially in slippery loads with reliance to the Anti Brake System and always follow the safety factors.

1- Locking Switch for Rear windows (Child Safety)

By pressing this button, rear lifting window switch (Left/Right) is deactivated.

By the first pressing, the keys are locked and by repressing of keys operation, is reactivated.

2- Flasher

Push the flasher button. All indicator lights and turn signal lights will flash simultaneously on instrument panel. This is an emergency action. Use this mechanism when your car is on crossing barrier position, or when you are in danger. Flashers will keep flashing even when the engine is off, therefore, turn them off after emergency.

3- Trunk opener button*

After the ignition switch is on, to open the trunk from inside the cabin press the button for about 1.5 seconds the trunk lid door will be opened.

4- Rear window heater

Push the related button to turn the heater on. One LED will light on the button when it is on.

Note: Only when the engine is switched on, rear glass heating can be activated.

Side view mirrors heater

Push the rear window heater button in order to protect side view mirrors against vapor and freeze effects.

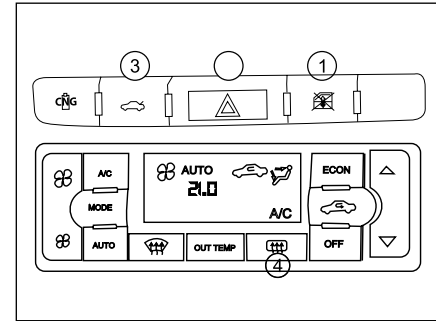

2



WARNINGS

Avoid rubbing and scratching the rear window and pasting any kind of label to protect the heater elements.

INTERIOR EQUIPPMENTS

2

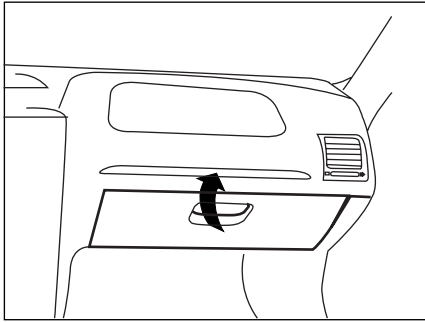

Opening dashboard

- Push the related lever to open the dashboard.
- A light will be turned on by opening the dashboard, which will be turned off after closing.

Note: Vehicle user manual booklet shall be usually kept in dashboard.

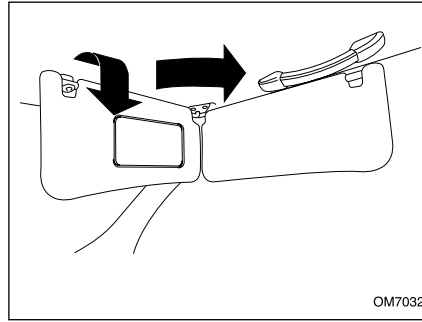

Sun visor

Push the sub visor downside in order to protect your eyes from direct sunlight. Sun visors are designed to be used for windshield and side shields.

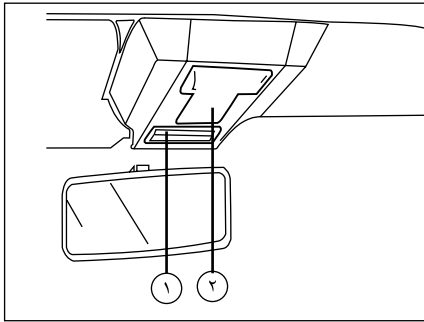

Interior Equipment

1-Front and rear ceiling lights:

- Pressing forward :Continuous light.
- Middle position :The ceiling lights will be on and off by opening and closing of the front/rear doors.
- Pressing backward: Off.

2- Map reading light (Study light): Turn the switch key to the right or left.

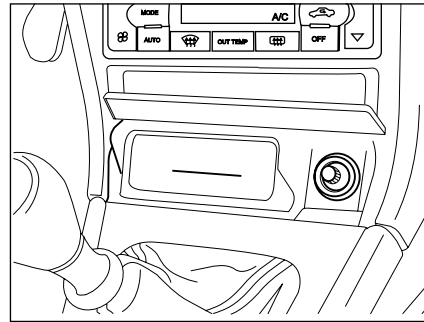

Front ashtray and lighter:

Press ashtray door to open the trap door. To discharge,pull out the ashtray.

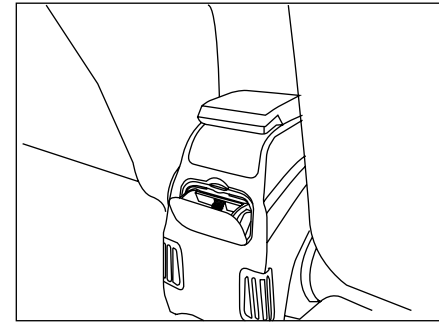

Rear ashtray:

Press the upper edges of the ashtray to open it and pull it out to discharge it.



WARNING



Ashtrays are dangerous spaces from fire catching point of view. Avoid putting paper pieces or other inflammable materials in it.

AIRBAG

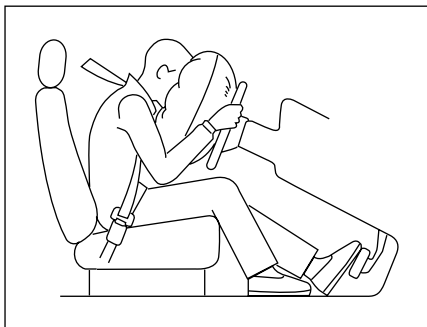
2



Air bag safety

Your vehicle is equipped with Air bag in addition to the pretensioner seat belt. The Air Bag is activated and protecting all passengers soon after the accident. When the ignition switch is turned to the "ON" position, air bag indicator on the instrument cluster gets on   and will get turn off again after blinking for 6 times.

Please refer to the authorized representative of IKCO, in case of observing any changes in indicator functions.



Warning

The following situations are indicating certain errors in air bag system or seat-belt, and you should immediately refer to authorized representative of IKCO.

- Indicator lamps will remain in on position after 6 times of flashing
- Indicator lamps are not getting on while the ignition switch is in on position.
- Indicator lamps are getting on while you're driving.

The responsibility of any accident will be on count of vehicle owner, if he/she doesn't refer to the authorized representative of IKCO.



Warning

Air bags are not operating while the vehicle is off and the ignition Switch is in off position.

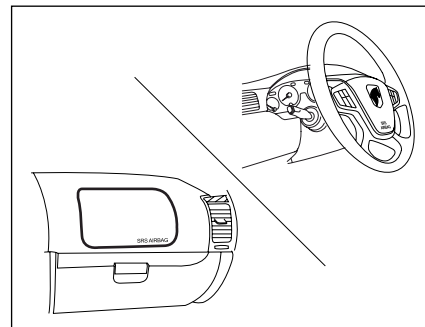

Driver and Passenger Airbag

Driver Airbag is located behind the central cap of steering wheel. SRS AIRBAG has been carved on it to indicate the presence of the Air bag.

Passenger Airbag is located in the top right of the dashboard.

SRS AIRBAG has been carved on it.



Warning

Covering of air bags area and pasting any object such as label (clock, mobile phone base, etc.) are forbidden. Putting objects in front of the chair in such a way that prevents passenger to sit down normally or cover the air bag It's dangerous.

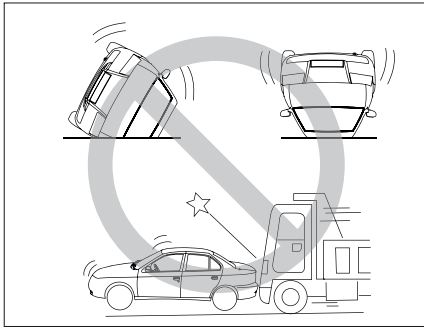

Important Note:

The front row airbag in the vehicle is designed in such a way that operates from front section and only during an intense crash; And it doesn't operate in the event of backside, lateral and rollover crashes or in light accident. This safety system has been designed to reduce the injuries and harms for passenger and driver and safety protection of them.

The airbag can only act once in a single crash. And it gets filled and empty so fast that you may not even be aware of its activation.

Activation of the air bag prevents your vision and it's not too tight so as not to allow you to get out of the car.

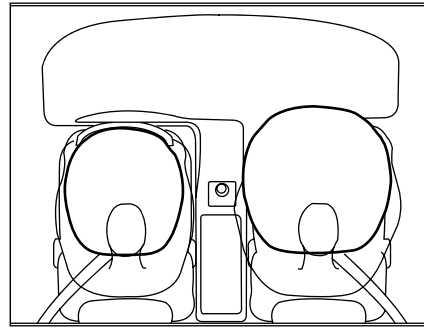

When the airbag is opened, a loud sound is created and a small amount of smoke is getting out without creation of any harm for the people.

Of course it may cause temporary irritation of throat or skin for the people with respiratory illness or those who have sensitive skin.

Avoid smoking during driving.

The fire of cigarette can cause serious injury when the airbag gets open.



Warning

It's necessary to know that no system can protect passengers against all possible injuries in a collision.

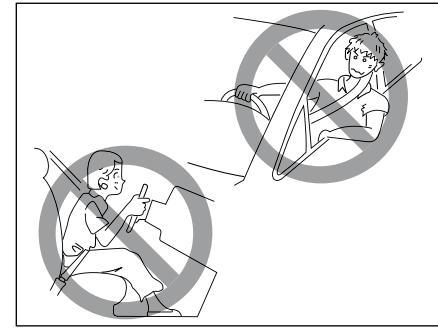

Relation between appropriate sitting and function of air bag and seat belt.

The air bag has maximum protective effect when the safety belt has kept your body in the proper position. So always adjust the seat in the farthest position possible, sit with a straight posture and lean on the backrest.



Warning

Air bags, safety belts, crash protection system are complementary. The driver and all passengers must be closed at all times your safety belt to the risk of serious injury or death in the event of an accident are minimized.

AIRBAG

2

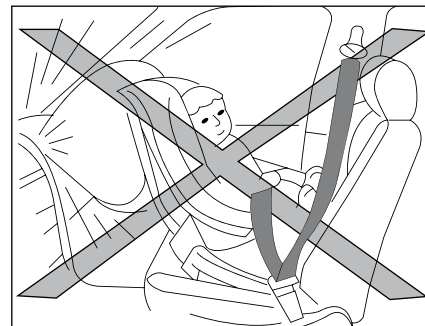
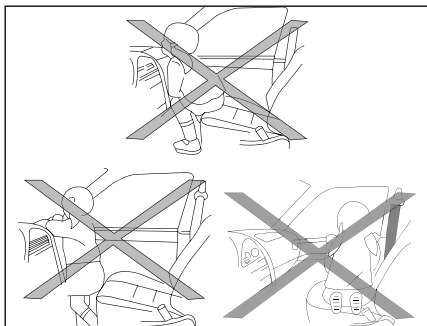

Warning

In the event of an accident, there is serious injuries for driver and passengers, if they don't wear a seat belt bend forward, or are positioned out of the chair.

Holding the driver's hand on the blades or central parts of the steering, placing legs on the dashboard and being too close to the airbag, will cause injury to the passengers in the accident while creating functional impairment of safety system.

Disabling of the passenger airbag

Disable Key of the passenger airbag is located on lateral side of dashboard section and provides the possibility of activating or inactivating passenger air bag.

The warning light of deactivation mode is turned on, on instrument panel , if the Air bag is deactivated.



Warning

Enabling or disabling front passenger airbag Should be done, when the vehicle is in off position.

The relevant warning light of deactivation must be turned off  Immediately after reactivating the Air bag.

As shown on the label beside the key, you should avoid placing the baby seat on the front seat towards the back of the vehicle, when the passenger air bag is activated.

If it's necessary to use the baby seat in front seat, you must either deactivate the air bag or place the baby seat towards the front side of the vehicle.

However none of the above cases are recommended to be done .

Seating of passengers on front seat is totally dangerous while the key is in off position .

please refer to the relevant section of this manual to check the safety points of children.

**Warning**

Do not allow children to seat in the vehicle without protection or take their hands out of the vehicle.

Do not put children on your feet and don't hug them. The possibility of severe injuries are there, if the children are not properly protected or if child seat is placed inappropriately in the front seat.

Do not install rear-facing child restraint system on the front passenger seat when there is a fault in function of the air bag arming or disarming switch.

SERVICE AND MAINTENANCE

If the airbag operates once, all its components must be replaced by authorized dealer of IKCO.

scrapping of the vehicle without removing of the air bag is very dangerous. Refer to the authorized dealer of IKCO to eliminate all activating armors of seat belt and airbag.

**Warning**

For information on checking periods or changing of airbag and safety belt refer to warranty manual.

**Warning**

Any servicing on the passenger security system (pre-tensioner, air bag, electronic control unit, wiring) or re-use of this system in another vehicle, even if is the same vehicle, is expressly forbidden. Use of standard components are strictly mandatory.

After any accident, the safety system must be rechecked. Any repairs, operations, and rechecking of the safety system must be done by authorized dealer of IKCO.

3 DRIVING

DIGITAL INSTRUMENT PANEL	78	FUEL ECONOMY.....	88
WARNING LAMPS	82	DRIVING & ENVIRONMENT.....	90
DIGITAL DISPLAY INSTRUCTION	85	WINTER PRECAUTIONS	91
STARTING AND DRIVING	86	STARTING AND DRIVING (CNG MODE)*	92

*If equipped

DIGITAL INSTRUMENT PANEL

Instrument panel indicators

Warning and indicator lights (above figure)

- 1- Low fuel warning light
- 2- Fuel gauge
- 3- Engine oil pressure warning light
- 4- Battery charge warning light
- 5- Brake oil level or handbrake applied warning light (two lights)
- 6- Brake pads wear warning light
- 7- Emergency stop warning light
- 8- Proof-meter warning light
- 9- Coolant fluid temperature indicator
- 10- High temperature of the coolant fluid warning light
- 11- Intelligent speed control system indicator *
- 12- CNG fuel indicator *
- 13- CNG engine digital instrument panel indicator *
- 14- ABS and EBD braking system indicator
- 15- Open door warning light
- 16- Air bag system activation indicator
- 17- ABS braking system warning
- 18- Immobilizer Indicator

Indicator lights and gages (below figure)

- 1- Anti-glare headlights
- 2- Tachometer
- 3- Left side flasher
- 4- Right side flasher
- 5- Engine digital indicator
- 6- Speed indicator
- 7- Adjusting the instrument panel illumination intensity
- 8- High beam headlight
- 9- Front fog lamp
- 10- Rear fog lamp
- 11- Anti-theft system indicator *
- 12- Driver seat belt
- 13- Activating gear box indicator *
- 14- Driver air bag indicator
- 15- Passenger air bag system deactivation warning
- 16- intensity of display light indicator
- 17- Fueling side indicator

*If equipped

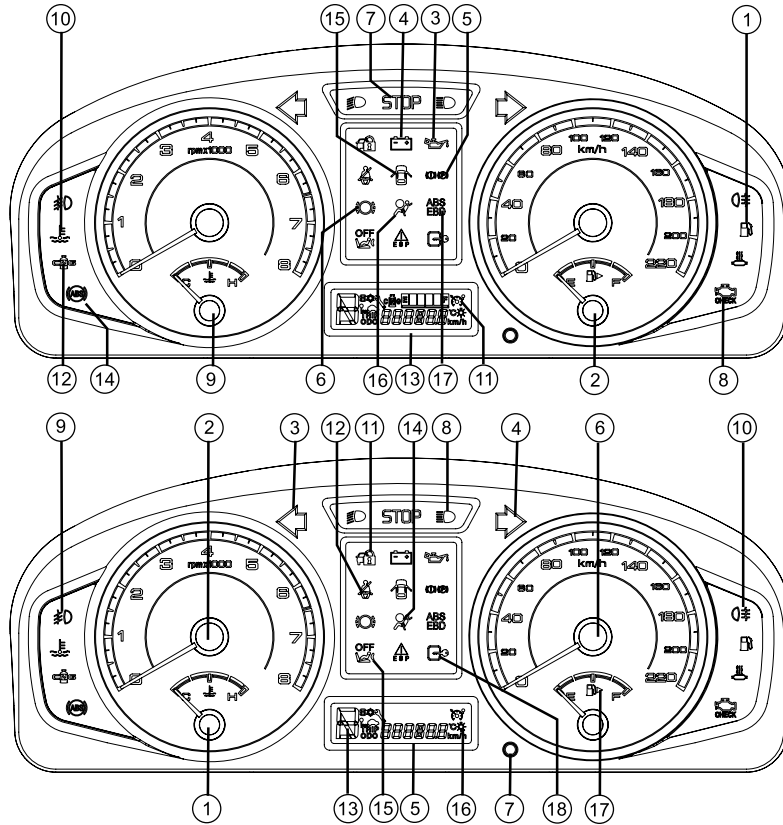

3

DIGITAL INSTRUMENT PANEL

Fuel Gauge:

The pointer falls to zero when the ignition switch is off, but it shows the tank fuel level when the switch gets on.

A warning indicator light in the fuel gauge lights up when the fuel level falls to 7 liters.

Refuel as soon as possible. Fuel tank capacity is 70 liters.

Tachometer:

It shows the engine speed in revolutions per minute. To avoid engine damage, never let the tachometer pointer remain in red section for a long time.

Speedometer:

It shows the speed of vehicle in Km/h.

Coolant Temperature Gauge:

This gauge indicates the temperature of the engine coolant, When the engine warms up, the pointer rises to the middle

of the gauge, and it remains until the engine operates in normal condition.

If the pointer reaches the red section, it shows that coolant is overheated causing damage to the engine. In this situation stop the vehicle immediately considering safety conditions and seek help from qualified persons to repair.

Possible Causes:

- A faulty fan- Check fuses, and change them if necessary.
- The coolant system leakage; let the engine cool down, and then check the coolant liquid level.
- A fault in the water pump operation

Distance Recorder Reset Button (Trip Recorder Reset Button):

It is used to show different situations in the digital display panel and reset information in the related condition.



Direction Indicators-Green

The directions of indicators (turning to the right and turning to the left) are defined by arrows. When you turn on the left or right signals, the corresponding green arrow on the instrument panel will flash along with the respective turn signal lights.

If the flasher (hazard warning light) is used, both indicators flash together. If either warning light flashes very rapidly, this means that the corresponding direction indicator is not operating.

NOTICE: This situation occurs only when one of the front or rear direction lights does not work properly, but if one of the side lights is not working, it will have no effect on the warning light flash frequency.

NOTE: If the vehicle experiences an excessive speed fall, the alarm system automatically turns on the flasher for at least 5 seconds.

This is a warning sign for excessive speed fall.*



Headlamp Dipped Beam - Green

It lights up when using dipped (dimmed) headlights



Headlamp Main Beam – Blue

It lights up when using main-beam headlights



Front Fog Lamp – Green

It lights up when using front fog lights – green



Rear Fog Lamp – Orange

It lights up when using rear fog lights.

*If equipped

WARNING LAMPS

STOP

The instant-red stop command

Central warning lights or the following warning lights are relevant: 1. Motor oil 2. Battery condition. 3. Engine water temperature Also, is relevant to the liquid temperature indicator of the cooling system. When the engine is switched on and, the lamp is flashing, it is necessary to stop the car,. Contact the Authorized Representative of Iran Khodro at the earliest opportunity.



3

Warning

If the **STOP** light comes on for any reason, driver should stop the vehicle. In case he continues driving, vehicle owner will be responsible for any resulted damages.



Automatic Engine Troubleshooting Device – Orange

This light gets turns on when the switch gets open and it gets off soon after the vehicle is turned on. If it is lit when driving, it indicates an error to the control systems of fuel injection or combustion. It indicates that the error is in ignition system, if the warning light is blinking, then the engine must be operated slowly. In this case contact, with an authorized representatives of Iran Khodro Co. as soon as possible.



Oil Pressure-Red

It lights up when the ignition switch is in the second position to indicate correct operation and it will turn off when the engine starts. If the oil light stays on when starting the engine or turns on when driving the car, the engine is exposed to a serious damage, the vehicle should be stopped immediately and the engine turned off while taking into account safety considerations . Get help from an authorized expert before moving the vehicle once again



Battery Charging – Red

It lights up as a bulb functioning check when the ignition switch is in second position and it will turn off immediately when the engine starts. If it remains on when starting or lights up when driving, there is a problem in the battery charging system. Immediately refer to the workshop to conduct repair.



Doors Open-Red

It lights up when at least one of doors is not closed properly. It operates even when the engine is off. Avoid driving when indicator lights up.



Brake System Alarm – Red

This indicator is turned on for a few seconds while starting the engine and then it turns off, and it turns on when the hand brake slides up or when the brake fluid level is low. If the indicator of brake system alarm doesn't work or remains on while starting the vehicle or after sliding down of hand brake, without delay fill the brake liquid reservoir and if the indicator remains on after filling the reservoir and sliding down of the hand brake, while considering safety precautions, transfer the vehicle to an authorized workshop for evaluation and repair.



Driver Safety Belt – Red

By locking of the metal tongue of the driver safety belt in the special buckle and with a "click", we make sure of its locking. With this action the indicator on the panel is turned off. If you do not fasten the seat belt, the audio warning, located in instrument panel is activated every 60 seconds, at speed of more than 10 km / h.



Anti – Lock Brake Warning System (ABS) – Orange

It lights up when starting the car and keeps on for a few seconds, and then it turns off. If it does not turn on when starting the engine or stays on after the engine starts running, it indicates that there is a problem in the anti-lock brake system. In such a condition move the car immediately and with safety considerations to the authorized workshop for inspection and repair.



Driver's air bag system warning – red

Starting the vehicle the indicator light blinks 6 times and then the vehicle must be turned off. Otherwise, (as below) suggests a fault in the air bag system which should be referred to the dealer of the car and fix it. Otherwise, the vehicle owner will be responsible.

- Air bag light stay on after blinking 6 times.
- When the ignition switch is placed in the ON position, the air bag light does not light up and does not blink.



Warning disabled passenger air bag - Orange

Turn on the lights indicate the passenger air bag is deactivated. Until the passenger air bag is deactivated, it remains light. In case of activating the flashing lights of the vehicle, please contact one of the Iran Khodro authorized dealers.

WARNING LAMPS



Brake Pads – Orange

It lights up to alert that the brake pads should be check and replaced if necessary.



Low Fuel Level Warning- Orange

Next to the fuel gauge there is a warning light, when the light is on it shows that less than 7 liters of fuel remains in the fuel tank. Refuel as soon as possible.



High Coolant Temperature Warning – Red

Beside the coolant temperature indicator, there is a warning light, if the coolant temperature pointer stands in the red section and the lamp lights up, stop immediately (without the engine turning off) and seek help from an authorized expert.



Theft Deterrent System- Red

It indicates that the theft deterrent system is activated when blinking.



CNG Fuel Position Indicator – Green*

If fuel consumption changes from gasoline to CNG the indicator will blinks, and if the CNG mode is running, the indicator turns on.



Immobilizer Indicator - Red

After turning off the car, the indicator flashes once per 4 second to indicate that the vehicle immobilizer system is activated.

Digital display screen guide

This display is located at bottom of the instrument panel (below the speed indicator) and shows you following information by pressing reset and change mode.

Push change mode knob quickly to switch between different modes. If you push it for about 2 second information of the same mode is reset to zero (information could be changed to zero).

Following information could be reset to zero:

1-When the ignition switch is turned to "ON" the display shows odometer. odometer records the total distance (km) the vehicle has been driven since being delivered to the owner. The tripmeter could not be reset to zero.

2-Trip meter indicates the distance (km) the vehicle has been driven since it has been reset to zero. Push reset knob for 2 second to reset the distance.

3-This indicates the pressure of the gas in the LCD and is made of 6 black stripes. When gas pressure is full the 6 stripes are active and by decreasing the gas pressure the number of these

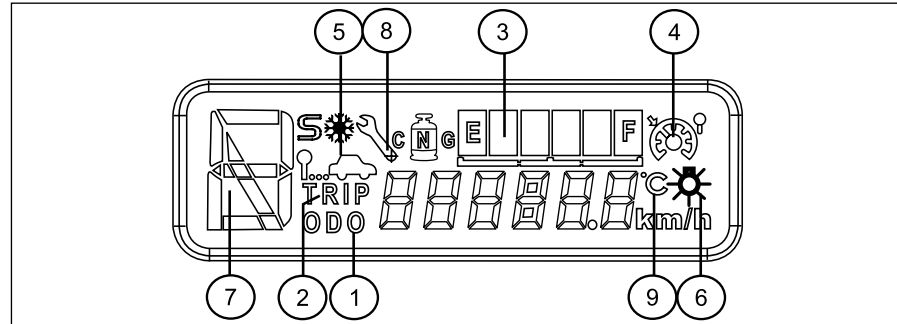

stripes decreases. Gas tank insufficient warning is indicated by the blinking of the first stripes in LCD and gas pressure become zero the last stripes goes off*.

4-If this indicator is on it means the intelligent speed control system is active and if it is off it means the intelligent speed control system is inactive.*

5- Functional display of automatic gearbox*

6-This indicates the intensity of the instrument panel illumination which could be changed by the illumination control knob. Push reset knob for 2 second, the indication starts to blink. Then every time that you push the knob one of the symbols comes on and the illumination intensity of the instrument panel increases. To exit

this state, just push the knob for 2 second.

7-Indicator of the automatic gear box position*

8- Service Indicator: If ABS· Brake Pads and or Air bag light lights, the indicator on the LCD turns on.

9- Outside Temperature Display

*If equipped

STARTING AND DRIVING

3

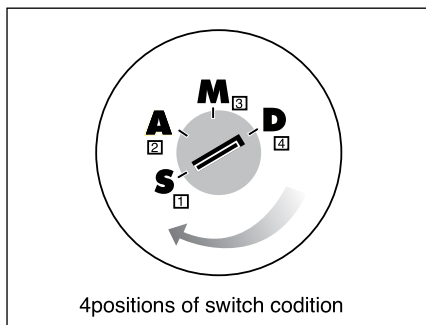

Ignition of Injector type Motors

Releasing of the lock for steering wheel:

Move the steering wheel slowly and turn the key in the switch hole.

Ignition switch

Has four positions

1- Position S: Main switch is closed. (Shut)

2- Position A: Electric circuit forelectrical equipments is connected but ignition circuit is disconnected. In this situation, the warning sign for charging battery lights up. (Aids)

3- Position M ignition of engine:

The ignition circuit is connected. In this situation, the following warning lights turn on:

-Reduction in motor oil pressure.

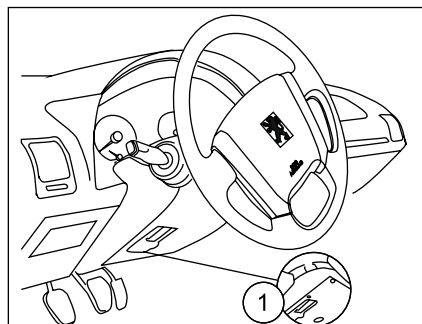

-Increase in temperature of liquid in cooling system.

-Charge of battery.

-Emergency stop. (Stop)

-Decrease in brake oil level or engagement of hand brake.

-Trouble shooter.

4- Position D Starting the engine:

- Immediately leave the switch key, after starting of the engine.

- When the engine is on, the warning lights will turn off.

Adjusting the steering wheel

To adjust height of the wheel:

-Press the lever until the wheel is out of lock.

-Move the wheel up and down, as desired.

-After adjustment, pull the lever until it gets locked.

WARNINGS



-Never adjust the steering wheel during driving. This is a very dangerous action.

-strictly avoid starting of engine and keeping it on for long time in confined spaces.

-when the vehicle is moving , avoid switching off the engine or taking out the switch key , because the steering wheel gets locked and steering will not be possible.

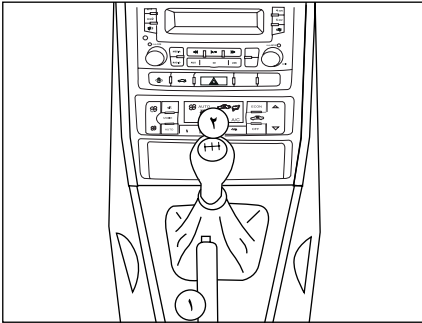

Manual gear box (Gear shift)

Useful recommendations:

Never intend to drive with cold engine. Never keep the engine working in confined spaces. When the temperature drops below zero degrees, push the clutch completely so that the engine starts easily. In cars with automatic gearboxes, the vehicle is turned on only when the gear is on P or N. *

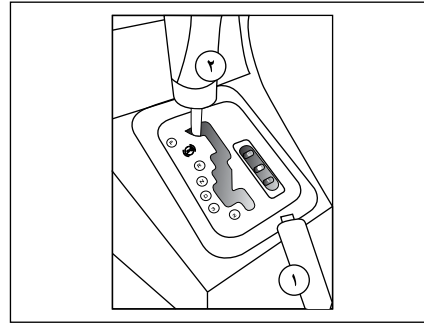

Manual brake

1-To lower the hand brake, press it's button.

Gear lever (Gear Shift):

2-The modes of changing Gear Lever is sketched on the head of Gear Lever. The reverse gear should be engaged only when the car is completely stopped and engine is running calmly.



WARNING

If the engine is off, the auxiliary brake system dose not work and more pressure should be imposed to the brake pedal. In this situation the stopping distance of the vehicle will be increased. Before moving your vehicle, take all safety precautions.

3



CAUTIONS

- When parking in a sloped place, turn the wheels towards the pavement and put on the hand brake and for vehicles equipped with automatic transmission, put the gear in position P.
- When icons (ⓘ)(Ⓟ) and **STOP** lights up, it shows that the hand brake is not released or badly released.
- During driving take care that the hand brake is fully released (the brake sign will be off), because there is possibility of warming up the linings.

*If equipped

AUTOMATIC GEARBOX *

3

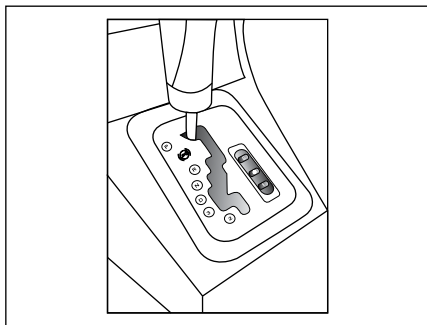

Automatic gearbox*

The four-speed automatic gearbox provides you the comfort of the auto-adaptive programme enhanced by dynamic driving conditions: from sport, driving on a slippery road to snow.

To select a given speed, shift the gear shift along the transmission plate. The position of transmission gears is clearly indicated by an indicator lamp on the instrument panel. The gear shift is only changed from the P position when the brake pedal is depressed, the engine is switched on or the ignition key is in ON position.

P : Status of Parking the Vehicle

R : This position is used for the vehicle reverse movement. Select this position with the vehicle stationary, engine at idle.

N : This position is used for switching on the engine or parking the vehicle with the handbrake on. If you shifted inadvertently into neutral while driving, wait a little bit for the engine speed to reduce to the desired level, and then shift into D for acceleration. This position is used also for long stops such as behind the red traffic light.

D : This position is selected for automatic gear shift while driving.

3 : **Automatic position for the first three gears.** Select this position when you shift the gear subsequently between 3 and 4 speeds (such as urban driving).

2 : **Automatic positions for the first two gears:** This position is ideal for mountainous roads. When you are driving upgrade or downgrade, shift into this position respectively for optimal use of engine output or management of the vehicle speed by engine brake.

1 : Shifting into this position, the vehicle will only move in the first gear (this is ideal for driving in steep slopes or towing). To use this position, select the first key when the gear shift is in position 2. To leave this position, press 1 key again or shift the gear to another position.



WARNING

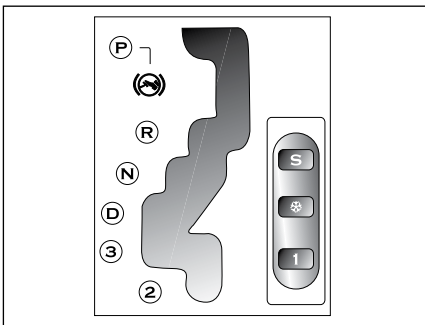

- Do not change gears in order to brake on slippery roads.
- Never use the N position while moving.
- Never leave children unsupervised in cars while the car is turned on. At vehicle's complete stop, pull the manual brake and use the P position.

*If equipped



The auto - adaptive Program*

There are three optional programs: Adaptive or ordinary, sport and snow programs.

Pushing either  or  key will cause the operational program from the ordinary mode and by pushing these two buttons again; either of these keys will resume the ordinary mode.

Under ordinary circumstances, your vehicle transmission will store the driving pattern in its memory and during the subsequent driving will select the best time to shift gears.

 : Program of racing conditions

By using this program, the gear shift will proceed and the vehicle will accelerate more smoothly.

 Snow program Once the gear shift is in D position, pressing snow key will facilitate the vehicle driving on the slippery and frozen surfaces. In this position, the vehicle will start on second speed and the gear shift will be done at low engine speed.

Operational Capabilities Specific to Automatic Transmission*:

- 1- Pressing the brake pedal for a while, the automatic transmission will automatically reduce to help braking by engine speed.
- 2- In the event you suddenly release the accelerator pedal for safety purposes, the gear will not shift to higher speeds.
- 3- While the engine is cold, the transmission will perform automatically to help raise the engine temperature to ideal rate in order to reduce the pollution.

Reverse gear shift*:

To make the acceleration ever better without shifting the gear lever, step on the accelerator pedal to the end. In this circumstance the transmission will automatically shift to lower gear or will remain in the same speed (depending on the vehicle speed) so as to raise the engine speed to the highest rate.



WARNING

-Any system failure will be indicated by a simultaneous blinking of the sport and snow lights on the instrument panel. Under these circumstances, the transmission will operate safely.

-Under these conditions, the possible knock upon the gear shift from P or N into R (reverse speed) is quite natural. Do not exceed 60 mph (100 km/ h) and have your vehicle checked by an IRAN KHODRO authorized dealer as soon as possible.

-While the engine is running, the transmission operates and the vehicle is at a standstill, the vehicle will move without depressing of the accelerator pedal.

-While the vehicle is at a standstill, do not step on the accelerator pedal simultaneously with the gear selection.

-While the vehicle is at a standstill, never step on the brake pedal simultaneously with the gear selection.

-While the transmission operates never depress the brake and accelerator pedals simultaneously.

-When stopping for a long time (like behind the red traffic light), it would be better to shift the gear into N position.

-While the vehicle is moving, never shift the gear into P or R position.

*If equipped

FUEL ECONOMY

3

Saving in fuel consumption

Four main factors in fuel consumption

1-Mechanical conditions of the engine:

Air filter: Dirty or obstructed air filter reduces the efficiency of the engine. Change the air filters at defined Distances.

2- Fuel system:

Check the injector system and fuel pump for any leaking.

Petrol: Quality of petrol not only effects the consumption of fuel, but also, in long terms, effects the mechanical conditions and operation of your car.

3- Conditions of the vehicle:

Air pressure of the tires:

Lack of enough air pressure in the tires, increases in fuel consumptions by 3%.

Carrying weights:

Carrying 100 kg of weight inside the city, will increase the fuel consumptions by 3%.

4- Resistance against the wind:

Driving with empty roof weight space , increases in fuel consumptions by 10%. Therefore immediately after finishing your job with roof weight space take it out along with wind breaker and it's mirrors. During Driving void opening the windows. it is better if you use the air vent channels.



WARNING

Do not place your car, when engine is still running, in spaces which there is possibility of contact with inflammable substances .(like dry grass, leaves,...)



CAUTIONS

The suitable petrol in your car, is the super petrol without plumb with figure of Octane of 95.

*If equipped

Saving in fuel consumption

-Driving:

Starting to move: Do not intend to drive fast, immediately after starting of engine. Drive slowly. Do not warm up the engine when you are not moving, but try to drive first few kilometers with average speed until the engine warms up.

Revolution per minute (RPM):

Driving with too high or too low RPM will increase in fuel consumption. To avoid unnecessary increase of RPM, quickly use the higher gear. Always use the gear which is suitable with the road conditions and calm driving conditions. Avoid sudden acceleration.

Before reduction of speed in a sloped road, and before over taking and accelerating, come down to lower gear. (specially from gear no.5)

Electrical devices: Use the electrical equipments, only when you need them. The rear glass heater, to remove sweating and freezing of the glass, increase in fuel consumption by 10 %.

The weather and road conditions:

Short distances: if the engine is cold in first 5 kilometer of driving, it will increase in fuel consumption by 25 %.

Spinal and unsmooth roads:

Driving in such roads, will increase in fuel consumption by 10 %.

Wind: Existence of wind during driving will increase the fuel consumption . Drop your speed in these situations. The optimum fuel consumption takes place in speed of 90 kilometer per hour.



WARNING

-To avoid excessive increase in RPM, in RPMs more than 6500, the fuel injection to the engine will be disconnected.

-Never put the engine under pressure before warming up. (Do not drive speedy)

If the engine dose not stop with the switch key, push on the brake pedal, engage the gear and leave your foot from clutch until the engine turns off.

DRIVING & ENVIRONMENT

3

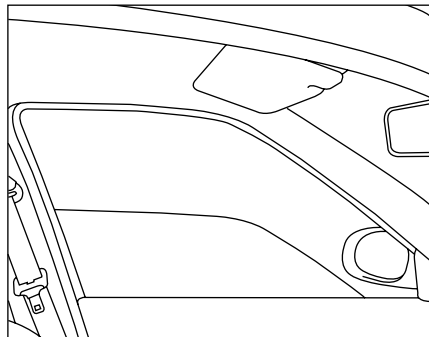
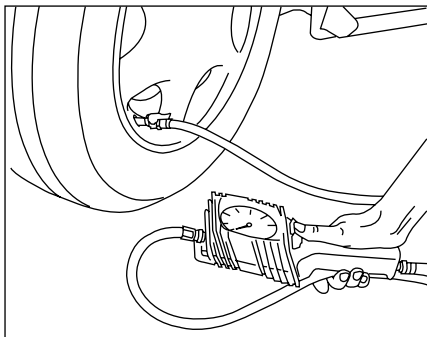

Driving & environment

You can reduce environmental pollution and drive more safely and economically by observing following advices:

- Use the factory recommended gasoline and engine oil.
- Prevent gasoline overflow while filling the tank.
- Do not forget to conduct periodic checks on your vehicle
- Check that the exhaust, oil and fuel system do not have any leakage.
- Begin driving slowly and right after turning on the engine.
- Turn off the engine for stops longer than 2 minutes (i.e in traffic jam or behind red light)

- Press the gas pedal slowly and do not speed up suddenly. Try to keep a steady speed to reduce not only exhaust pollutants, but to prevent mechanical parts erosion.
- Pay attention to the maximum allowed speed.
- Adjust tires pressure and balance them if necessary.
- Minimize using the air conditioner to reduce fuel consumption.
- If you changed the engine oil by yourself, do not drain the used oil and deliver it to the refill oil stations for recycling.
- Plan your trips, and combine them together.

- Avoid driving in busy streets or rush hours as much as possible.
- Use electronic equipment when strictly necessary.
- Under- inflated or non- standard tires raise fuel consumption.
- Avoid driving with open windows; it is preferable to use the ventilation (it raises to fuel consumption).
- Avoid fastening the empty roof weights pace on the vehicle.
- Tire is not approved by the manufacturer can increase fuel consumption.
- Non- balanced tires will increase fuel consumption.

Winter precaution

Tires:

Winter tires: if you are using the car in hard winter conditions like in snowy, freezing and slippery loads, to select the required equipments, with regards to the conditions, consult authorized IRAN KHODRO representatives.

Four season tires:

To gain a higher speed in favorable weather conditions, all four wheels of the vehicle should be equipped with four season tires, so that the stability of the car can be maintained better.

Wheel chains:

In PEUGEOT PARS ,the wheel chains should be attached to the front wheels. The chains should be same size of the wheels and be fixed to it, otherwise they cause severe damage to the brake system

Motor:

Battery: Specially in winters ,make sure the battery is charged.

Engine cooling system: In cooling system of your car, a kind of cooling liquid is used that can ensure resistance against freezing or system internal chemical erosion. This solution which to be used in all four seasons of the year, protects the system in temperatures down to minus 20 degrees centigrade.

In any case the system can be protected in temperatures down to minus 35 degrees centigrade, which in this case, the authorized representatives should be consulted.

Safety of vehicle

Detach the tag of the key no of your vehicle from the key hole and keep it in a safe place. After removing the switch key, turn the steering wheel until it gets locked.

Safety of the road

Safety belts

According to regulations, use of Safety Belts are compulsory. There should not be any modifications to it's installations.

-in wet roads, lack of adhesiveness of the tires with the road and also delay in brake operation due to wetness, causes slipping of the car and increase in stopping distance.

Tires:

Check the air pressure of the tires, regularly. The difference in air pressure of tires can effect in returning the steering wheel.

Front lights and side lights

Take care that the front lights and side lights are in good working conditions and clean and their lights are adjusted at correct and suitable height.

Safety in vehicle movement:

Hand brake:

At freezing temperatures, avoid parking your car for long times. In these kinds of situations, obstruct the front wheels with something or clutch the gear on gear no.1 or the back gear.

Main lights and side lights: The front lights and other lights should be always clean.

Interior and exterior equipments of the vehicle:

The locks and the rubber packings of the doors: Grease the door locks with a little Graphite

contained oil and Oil the Rubber packings with paraffin.

The flaps for entering air into the cabin:

Take care that the outer channels for letting Air inside the cabin (beneath the front glass) is not obscured by snow, ice or leaves in any case.

Front Wind shield wiper:

Before operating the wipers, clean the ice patches on the front glass.

The front glass cleaner:

To avoid freezing of liquid inside the container, add a little anti freezing solution to the glass cleaning liquid.

THE BODY:

At the end of winter season, wash the car completely and pay required attention in washing beneath of the body and the mudguards.



WARNING

Never intend to drive in slopped grounds with engine OFF. The brake booster dose not operate in this situation.

CAUTION

In vehicles exported to cold climate areas, having very difficult winter conditions, a kind of cooling solution is used which can protect the cooling system of the car up to minus 35 degrees centigrade.

STARTING / DRIVING (CNG)

3

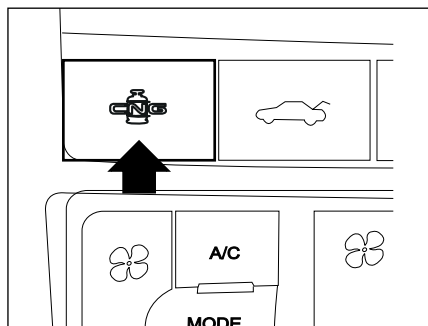

Starting the Engine on CNG Mode*

To remind you, this method is used only for special situations like gasoline shortage. First turn the switch on, and then press the conversion key for 5 seconds till the green light will appear on instrument panel the green light, appears on the instrument panel. Then start. If there is no technical malfunction in the gas system, the engine will start on CNG.

Fuel Conversion Key

The fuel conversion key is on the middle console next to the digital clock and it is used from switch from gasoline to gas and vice versa mode. By pressing the related key, the fuel type can be changed.

Starting & Driving On CNG Mode*

Changing the type of fuel is done by the fuel conversion key located on the middle console and you can choose the type of fuel as follows:

- A. Before moving (at first the car will start on gasoline then it will switch to gas)
- B. During driving
- C. Starting the car directly on gas mode**

Starting the Engine

The engine starts on gasoline mode. Since gasoline pump is turned on, even when the car runs on gas, and also to cool fuel injectors, it is necessary to have at least 5 liters of gasoline in the fuel tank. In the case of any damage to gasoline system, the engine finally starts on gas mode.

*If equipped

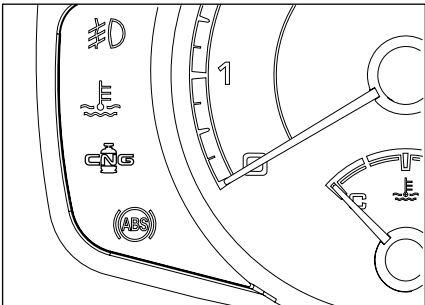

Conversion from Gasoline to Gas*

While the engine is operating on the gasoline mode, by pressing and releasing of fuel conversion button, the corresponding indicator on the instrument panel LED will start blinking which denotes that the fuel conversion has not taken place. After a while which depends on the engine water temperature at the moment, the conversion button is pressed down (e.g. under the engine water temperature of 25 °C, this time will be equal to 150 seconds, while under higher temperatures the conversion time will be shorter), the CNG indicator will stop blinking and the light comes on permanently. This implies that the fuel conversion has taken place completely. Now the engine is working on CNG mode .

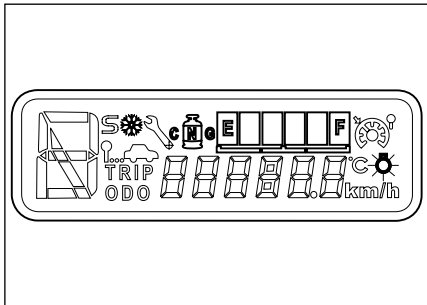

Conversion from Gas to Gasoline*

By pressing the fuel conversion button, in the case that there is no engine failure and enough gasoline in the fuel tank, the director on the instrument panel will light off. This implies that the conversion from CNG to gasoline has done properly. It is necessary to remind that under the two following circumstances , the engine will automatically convert from CNG to gasoline option(no need to press conversion button) :

- Breakdown of CNG consumption system
- Non- availability of sufficient gasoline in the fuel tank.

NOTE

In the event the engine REV is higher than 4000 revolutions per minute and it is accelerating up at the moment the conversion button is pressed down, the LED indicator will start blinking and the engine will remain on CNG as long as it has not left the REV domain, after which it will convert to gasoline.

In the event the engine REV is higher than 4,000 revolution per minute and it is accelerating on up, by pressing of the conversion button, the indicator on the LED will start blinking and the engine will remain on gasoline as long as it has not left the REV domain, after which it will convert to CNG. It is worth mentioning that in the cases above, the conversion to CNG will take place automatically without the need to press the conversion button.

*If equipped

STARTING / DRIVING (CNG)

3

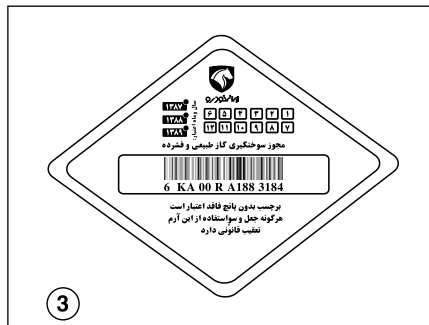
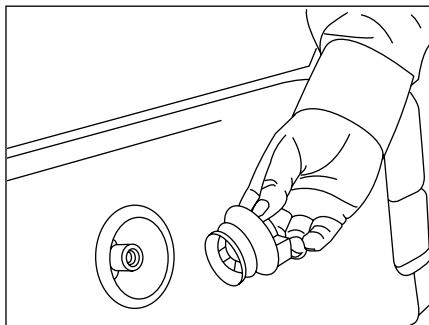

WARNING

The CNG gas and the other equipment must be assessed through assessing centers (approved by ISIRI), every 36 months.

Steps of receiving CNG fuel: *

- 1- Before arrival to the Gas station and during stay in there, strictly avoid smoking and operating your mobile phone.
- 2- After arrival to the Gas station **, the Driver should switch off the engine and make sure that the car is completely stationary. (Put on hand brake).
- 3- the operator of the station, after

- controlling the permit sticker for fueling the vehicle, performs fueling Operations.
- 4- After every fueling make sure that the Gas filling manifold cover is completely closed. (closing the cover properly is necessary, to avoid entrance of dust and dirt and subsequently, problems in Gas system).
- 5- The maximum authorized pressure for fueling is 200 Bars.

The method of renewing the permit sticker for fueling the vehicle*:

Expiry period of permit sticker for fueling from the time of issuance, is 12 months and without fueling permit, permission for fueling will not be granted in Gas stations. Therefore one month before date of expiry of the sticker, attend the authorized centers for inspections of binaural fuel consuming cars.



CAUTIONS

- The maximum number of fueling operation in the tank is 1000 cycle per year. Charging of the tank should not take place more than 3 times a day, approximately.
- Strictly Avoid fueling in Gas stations specialized for buses and heavy vehicles because there is possibilities of malfunctioning in manifold valve of the tank and it's accessories, with regards to higher outlet Debbie of the station.

**to get latest information regarding conditions of active CNG stations, you can refer to web sight: related to Association for improving fuel consumption or contact with following telephone numbers: 88604760- 5.

*If equipped

4 VEHICLE MAINTENANCE

MAINTENANCE	96	HYDRAULIC STEERING.....	103
ENGINE COMPARTMENT	98	BATTERY	104
COOLING SYSTEM	101	CLEANING & CARING VEHICLE	105
BRAKES	102		

MAINTENANCE

Owner Care & Maintenance

In addition to regular services and checks described before, some simple periodical checks should also be done. By paying attention to the recommendations in the next pages, you, yourself, can perform these checks.

Daily checks

- Performance of lights, horn, indicator lights, window wipers, window washer and alarm lights
- Performance of safety belts and brakes
- Any drips of any liquids that may indicate the leakage of engine liquids under the vehicle.

Weekly checks

- Engine oil level
- Coolant level
- Brake fluid level
- Steering wheel hydraulic oil level
- Window washer liquid level
- Air pressure in tires and their condition
- A/C performance

Special Conditions

If your vehicle is constantly used under special conditions such as places with a lot of dust or in very cold weather or very hot places, it needs extra care. Contact your authorized representative in this regard.

Safety in the Garage

If you need to carry out maintenance, consider the following safety advices:

- Keep away your hands and clothing from moving belts and pulleys.
- If the engine has been turned off recently, do not touch the exhaust, cooling system and its auxiliaries.
- Do not touch electrical connections or its other components when the engine is running or the switch is on.
- Never leave the engine running or start in a closed place since exhaust emissions are poisonous and very dangerous.
- Do not work underneath the car when jack is the only means of support.
- Ensure that bare wires and all sparking tools are away from the engine.
- Use protective clothes and impermeable gloves for maintaining operation.
- Put off the metal wristbands and jewelry before working in the engine compartment.
- Prevent tools or metal objects contacting battery poles and terminals.

Routine Services

The safety, reliability and performance of your car is partly dependant on your maintenance skills, and you should become ensured that maintenance operations, oil services, checks, brake fluid and coolant topping up are carried out in accordance with the proposed schedules of the manufacturer if required.

Poisonous Fluids

All fluids used in a car engine are poisonous and should not get any contact with open wounds. These liquids include battery acids, anti-freeze, brake and hydraulic fluids, gasoline, oil and the washer additives. Pay attention to instructions written on the labels and containers filled with these fluids.



WARNING

- If the vehicle moves at high speed for a long time, check the engine oil's level regularly.
- Any sudden or significant decrease in the vehicle's liquid level or uneven friction of the tires should be reported to the authorized representative as soon as possible.



WARNING

The cooling fan is an electrical device, and may continue operating for a few minutes after the vehicle has been turned off. Keep out of the operating fan when working in the engine.

A long contact with engine oil may cause serious skin disorders as dermatitis and cancer. Wash your skin carefully if contacted.

ENGINE COMPARTMENT

4

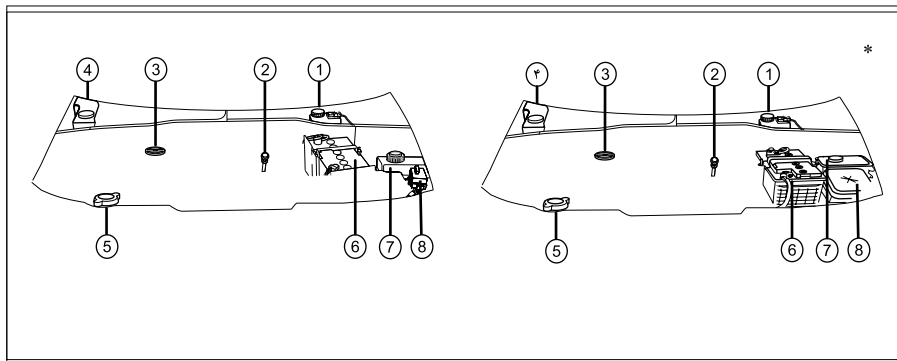

The Parts in the Engine Compartment

- 1- Brake Fluid Reservoir
- 2- Oil Dipstick
- 3- Oil Filler Cap
- 4- Washer Reservoir
- 5- Radiator Cap
- 6- Battery
- 7- Hydraulic Fluid Reservoir
- 8- Engine compartment fuse box



CAUTION

Adding: when adding oil, ensure that it is not spilt on engine parts there may be danger of fire.

Do not forget to close the lid since there is the danger of fire due to oil splashing on the hot surface of the engine parts.

The indicator will only warn in engine oil goes below the required level and never shows any increase over the maximum amount, which can only be determined by reading the gauge.



WARNING

- The cooling fan is an electrical device, and may continue operating for few minutes after the vehicle has been turned off. Keep out of the operating fan when working in the engine.

- A long contact with engine oil may cause serious skin disorders as dermatitis and cancer. Wash your skin carefully if contacted.



WARNING

- If the vehicle moves at high speed for a long time, check the engine oil's level regularly.

- Any sudden or significant decrease in the vehicle's liquid level or uneven friction of the tires should be reported to the authorized representative as soon as possible.

*If equipped

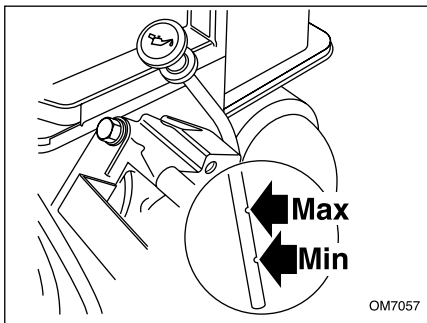

Checking the motor oil level:

Check the motor oil level weekly or in case of continuous usage of the car, check it several times per week. Check the oil level when the engine is hot and vehicle is situated completely horizontal and the oil is stationary in the cartel.

Inspection of Engine Oil Level

Put the car on a flat surface. Turn the engine to warm it up. Turn off the engine and then measure the oil level after 5 minutes.

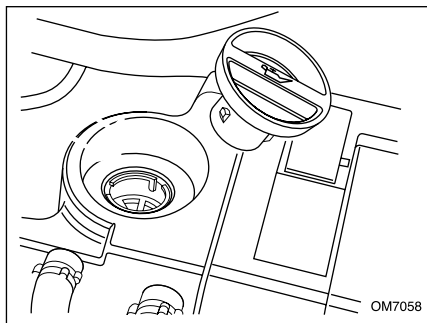

Purring motor oil:

Take out the cap for motor oil manifold. Pure the oil into the tank space. The level of the oil should never exceed the sign of (MAX) on the oil measuring rod. To get information regarding specification and volume of required motor oil, refer to section of **Technical information**.

The applicable engine oil in this vehicle must be 20W50 SL / SJ, 10W40SL.*

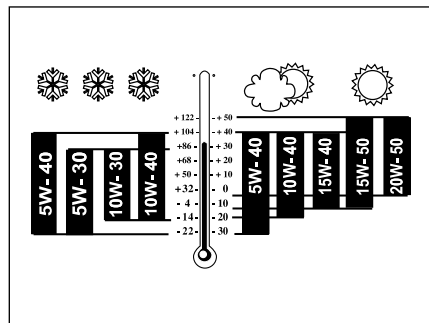

CAUTION

Never mix the Motor oil with additive materials. This can cause serious damage to the engine.

*It's recommended to use the approved brands and packages, offered by the Isaco.

ENGINE COMPARTMENT

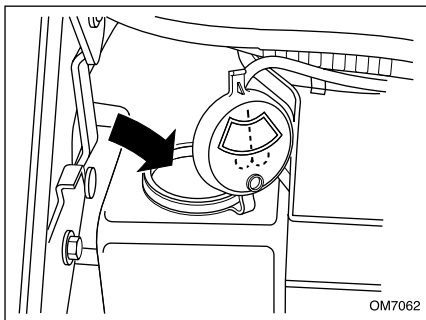

4

Filling of glass cleaner container:

Check the water level of the glass cleaner container weekly. To ensure clean washing of the glass and avoid freezing, fill the container with mixture of water and a suitable detergent. Mix the recommended amounts of water and detergent in a separate bowl and fill the container with it. Always follow the instructions mentioned on washing liquid container.

Washing solution of glasses must be Iso Propanole.*



CAUTION

Never use mixture of anti freezing liquid and water for glass cleaners. This will damage the paint work of the car.



CAUTION

Change the air filter at regular intervals. If you are using your car in a dusty atmosphere, reduce the time intervals to half.



WARNINGS

- During working on engine, the radiator Fan may start working any moment. (Danger of injury)
- **Adding oil:** When adding oil take care not to pour the oil on the engine parts because there will be danger of catching Fire. Do not forget to put the cover back, because there will be danger of catching Fire due to splash of oil on hot parts of the engine.
- **Changing Motor Oil:** If you are changing the motor oil whilst the motor still is hot, take care not to be burnt by splash of hot oil.
- **Do not start the engine in confined spaces:** The exhaust gases from exhaust pipe is Toxic.

*It's recommended to use the approved brands and packages, offered by the Isaco.

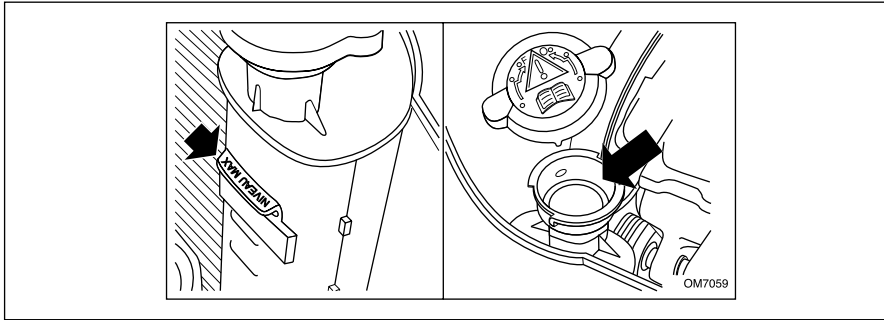

Checking the Coolant

The coolant level should be checked weekly when the cooling system is cold, and the car resting on a plane level. Liquid level should stand between (Max) and (min) signs on the vertical wall of the radiator (next to filler cap). Top up the radiator on necessity.

Filling the Radiator

If the engine is warm, wait 15 minutes until the engine temperature falls below 100 C. Protect your hands with a cloth and unscrew the filler cap carefully and slowly to the safety stop, letting radiator pressure fall.

NOTICE: If more than one liter is needed to top up, an authorized representative should check the cooling system. Make sure that it is

fully tightened to the second thread.

In an emergency, and only if the recommended anti-freeze is not available use clear water to fill the cooling system, but be noted that it reduces coolant freezing protection. Always use the antifreezes with recommended formula and approved brands and packages that are offered by ISACO.

Important Note: Cooling system draining and refilling are service operations that need sufficient knowledge, and should be carried out by qualified personnel according to the instructions of the repair handbook. It is necessary to replace the coolant every two years. The coolant resists freezing down to - 30 degree centigrade.

Anti-Freeze

Anti-Freeze contains corrosion inhibitors. Anti freeze content of the coolant should be maintained between 40-50%, not only in cold weather but also all the year.



WARNING

The evacuation must be done by authorized deal of IKCO ,if any of cooling system (except radiator) gets open or repaired .

Avoid opening the radiator cap unless the vehicle is off at least for an hour.



WARNING

Anti-freeze solution is poisonous, and could be fatal if swallowed. Keep it sealed and out of children's reach. If you suspect of drinking it, refer to the physician immediately.

Prevent anti-freeze solution contacting with the skin and eyes. If you accidentally get it in your eyes or on your skin, flush the place with water and get medical help immediately.

BRAKES

Brake system

The most important part of safety in your vehicle, means brake system, is equipped with disk brakes in forward, bowl brakes at the back and also a binaural hydraulic system.

When the engine is on, the brake boosting system, reduces the required force for pressing the brake pedal.

4

Brake oil

With continuous using of the car, the level of the oil may be reduced due to the erosion of the linings and there is a need to add brake oil. If in short period of time you notice a considerable reduction in oil level, refer to authorized representative. If the level of oil is less than minimum marked level on the container, stop driving.

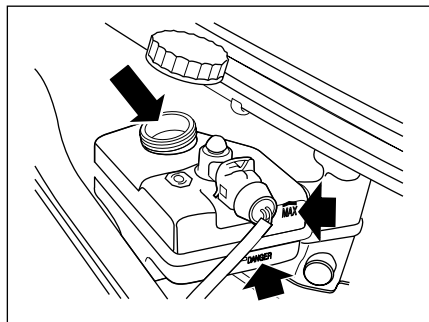

Checking the brake oil:

To avoid entrance of the dusts into the container, clean the cap of the container first and then open it and fill the container up to (MAX) sign with brake oil.

Do not let the level of oil comes down less than (MIN) sign. Only use fresh oils in a sealed containers. (old or opened oils or oils which were leaked from the system before, absorbs the water and using

them again, creates negative effects on operation of the system).

Just use the standard brake oils and approved brands and packages that are offered by ISACO.



CAUTION

Brake oil damages the paint work. In case, first collect the oil with a piece of clean cloth and then wash the area with water and especial car shampoo.



WARNING

The Brake oil is strictly Toxic and it should be kept in a closed container away from reach of children. In case of swallowing brake oil, immediately consult a doctor.

- Avoid contacting with eyes and hands. In case of contact with skin, wash the area with lots of water and in case of contact with eye, after washing, consult a doctor.
- Due to danger of catching fire, take care that the brake oil is not purred on the hot engine.

Hydraulic steering wheel

If the Hydraulic steering wheel, is working properly, there is no need to add extra oil in the container and if it is necessary, it will be very little. In case of sudden or frequent reduction in oil level, the car should be investigated by authorized representative. If the oil level is lower than the minimum sign on the container, fill the container before starting the engine, otherwise, the hydraulic pump for steering wheel, will get damaged.

In case of reduction of oil below the minimum sign, or it's fast and considerable drop, do not use the vehicle under any circumstances. In spite of this, if the reduction of oil is gradual, you can fill the container up to maximum sign and with making a short distance, take the car to nearest authorize work shop for trouble shooting.

Check the oil level weekly. When checking hydraulic oil level, the engine should be off and cool and the wheels should be straight.

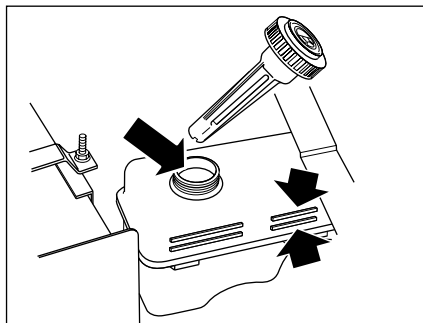

Checking the Hydraulic oil level for steering wheel

To avoid entrance of the dusts into the container, clean the cap of the container before opening it. Take out the cover and clean it's rod with a piece of clean and coreless cloth. Put it in it's place again and to check the level of oil take it out of container. In case of shortage of oil, add oil until the level of oil comes somewhere between the minimum and maximum level.

Do not put extra oils in the container. (More than required)

To get information regarding recommended oil specifications, refer to Maintenance and Service Guide.



CAUTION

Brake oil damages the paint work. In case, first collect the oil with a piece of clean cloth and then wash the area with water and especial car shampoo.



WARNING

The hydraulic oil for steering wheel is strictly Toxic and it should be kept in a closed container away from reach of children. In case of accidental swallowing, immediately consult a doctor.

In case of contact of hydraulic oil with skin or eye, wash the area with lots of water . Due to danger of catching fire, take care that the hydraulic oil is not purred on the hot engine.

BATTERY

4

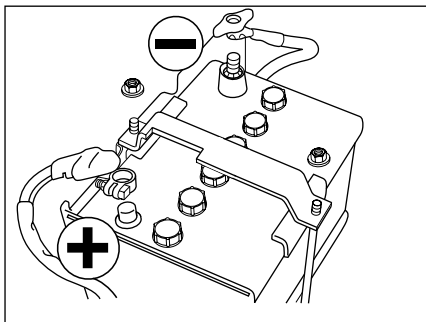

Disconnection of battery

Before disconnecting the battery, switch off the anti theft system and make sure that the main switch is closed. First disconnect the negative cable (-) and then the positive cable (+). For reconnection, first connect the positive cable and then the negative cable. Do not let the poles of the battery come in contact with body and other metal parts of the car. To take out the battery, first open the clamps of the battery and take them out. For repositioning, first place the battery and it's clamps precisely in their positions (it's poles should be pointing the engine) and then tighten the nuts in such a way that the battery dose not move, but not too tight.

Changing the battery

Always use batteries that their type and specifications are like the original battery of the vehicle. Other types may have different size or poles. Their connection to electrical system of the vehicle may have danger of catching fire.



WARNINGS

The acid contained in the battery is Toxic and corrosive. In case of it's leakage, note the followings:

-in case it is in contact with cloth or skin, immediately take out the infected cloth and wash the contacted skin areas with lots of water and consult doctors.

-In case of contact with eyes, immediately wash the eye with clean water for at least 15 minutes and quickly consult a doctor.

-If the required medical attentions do not take place immediately, swallowing acid can be fatal.

-The battery which is being charged, emits explosive hydrogen gas . take away any sparks and flames from engine space.

During working on engine space, for your own safety, take out your bracelets and ornaments .

Never allow the poles of the battery , contact with tools and metal parts of the car.a



CAUTIONS

-If the car was left unused for more than 6 days ,it should be switched on at least once and continue being on for one hour.

-If the car is not going to be used for long time, you should disconnect the battery cables . In this situation charge the battery every four weeks.



WARNINGS

-Do not charge a battery which is suspected of being frozen.

-During battery charging , keep away any spark or flame from it (charged battery or the battery being charged will emit flammable hydrogen).

- After charging of the battery, and before it's connection to the vehicle, wait for an hour so that flammable gases exit from it and danger of inflammation is reduced.



CAUTION

-Do not charge the battery when it is connected to the vehicle. This may cause serious damage to electrical systems of the vehicle.

-It is better to check the level of the water and acid in the battery, in case the caps of the battery can be opened, up to the maximum level marked on the body of the battery every month and in case of shortage of water and acid, Distilled water to be added.

Recommendations for washing the vehicle

1- Wash vehicle at least once per week if weather is normal.

2- Wash vehicle away from direct sunlight

3- Start washing at least 30 minutes after engine has not been running.

4- Do not use cloth and / or hard materials which can scratch the paint during washing/wipe off. It is recommended to wear plastic gloves during washing. Use warm or lukewarm water for washing. Never use hot water. Meanwhile it is recommended to use waxes and polishers which are not abrasive or erosive.

5- Do not stand on the door step and do not depress the vehicle's roof and body during washing / wipe off. Meanwhile it is recommended to use leather or cotton cloth for wiping off and polishing to avoid scratching the paint.

6- Since the brake's dust is very corrosive, first wash the wheels, then change the cloth and the washing solution and wash other parts of the vehicle from top to bottom. Wash Aluminum wheels and Chrome metal sheets with a water and mild soap using a soft and clean cloth. Wheels surfaces are very sensitive such as the vehicle's

paint. Do not use strong chemical and/ or acid substances and also abrasive and erosive materials such as chrome polishers. Chrome polishers should be used only on the Chrome metal sheets on the Aluminum wheels.

7- Pay more attention to the pressure and temperature of water while you're washing the vehicle with high pressure water. Keep the nozzle at least 30 cm away from the vehicle body through out the entire washing. Don't use the nozzle for the certain parts of the vehicle such painted bumpers, damaged parts and lamps, rather use the hand to clean these parts.

Don't keep the nozzle for a long time on a surface. Take care more while you're washing the slits of the doors and all around the glasses. Prevent spraying the water on the locks through the nozzle.

8- Suitable detergent for washing vehicle:

- Low basic (PH=7-9)
- Proper lubricant to protect the paint from scratching. Use preferably fluid detergent.
- Free from materials which affect on vehicle after drying;
- Containing polisher ingredients to

maintain gloss and dry quickly.

9- Do not wash the vehicles, having metallic and two coverage paint, by using automatic carwashes which use rotary brushes;

10- Foreign material such as bird droppings, tree sap, etc. may damage the finish of your vehicle. Remove these types of deposits as quickly as possible.

11- If the water permeates to the luggage compartments and interior parts of the vehicle, dry it immediately.

CLEANING & CARING VEHICLE

Cleaning the Bodywork

In order to preserve the car painting finish, please consider the following advices.

- **Do not use hot water** to wash the car.
 - Use wet linen cloth to clean dirt and dust from the car metallic paint to prevent scratching.
 - Do not use detergent powder or washing liquids.
 - In hot weather, do not wash the car in direct sunlight.
 - Do not flush the water directly to the windows, door liners or the brake components.
- Avoid putting the the foot pad on the vehicle body .Otherwise it will change the color of the body by the course of time.
- Use a water hose to flush dust and dirt front the bodywork before washing, and when the car is too dirty. Then wash the car with cold water or lukewarm water and a good quality shampoo.
- Use plenty of water to make sure that the bodywork has become free of dust. Rinse the car with clear water and soak up using a chamois leather cloth.

Cleaning The Underneath

Occasionally and especially in winter, flush away mud from underneath of the car such as the wheel compartment and frame gaps (seams), which can easily collect debris.

Do not flush water directly to susceptible areas.



CAUTION

- In some high pressure, water penetrates in doors and windows liners, and cause damages to the locks. Do not use high pressure water on sensitive parts
- Blue straps on the trim, side mirrors, windows, fenders & ... should be detached. otherwise it may cause problem.

Use the following materials to wash the exterior of the vehicle:

- Car shampoo
- Wax polish
- Tar remover
- Glass cleaner
- Rubber protector
- Cleaner of rings and aluminum

Cleaning of Tar stains

To clean the tar and grease stains ,use white alcohol. Then wash the area with water and soap till the residues of alcohol disappears.

Plastic parts:

First clean these parts with diluted washing liquids. Then clean the area with wet cloth. Do not shine front dashboard areas. This place should not shine , so that it's reflection in front glass , dose not obstruct the driver's vision.

Floor mat (Carpet)

Use diluted home cleaners, like carpet shampoo and to avoid change of color, dry them up in the shades.

Paint polishing of the body

Sometimes use good quality polish containing following materials to finish up the paint works:

- Eroding soft particles to remove surface stains without damaging the paint.
- Filling materials for removing or covering the scratches on the body paint work.

-Wax for creating protection shield between the paint and foreign objects.

Blades of the wipers

Wash the blades with warm water and soap. Do not use alcohol or petrol cleaners.

Glasses and Mirrors

Regularly Clean the glasses from inside and outside with a high quality glass cleaner.

Front glass

Wash the front glass with glass liquid cleaner, specially after polishing and cleaning of body and before installing new wipers.

Rear glass

Clean the interior side by soft cloth with left and right movements so that there is no damage to the heaters . Do not clean the glass with eroding cleaners. This will damage the heaters of the rear glass.

Mirrors

Wash the mirrors with water and soap. To remove the ice patches from the mirror surface, use plastic pallet knife.

NOTE: Never use metal pallet knife or eroding cleaners.

Interior parts of the vehicle

Seats: To clean the dirt from the surface of the seats, use standard cleaning materials.

Dashboard: To protect the dashboard, there is no need to use covers, because it is very resistible against sun light, heat and coldness.

To remove grease stains and other dirt from dashboard, only use cleaning materials...

CLEANING & CARING VEHICLE

Maintenance of the Vehicle's Natural Leather*

Natural leather requires care to keep its beauty and durability. Clean any spots, whether made by foodstuff, alcohol or liquids, using an absorbent cloth. In case of water being spilt on the leather, do not use hair dryer or brush to dry it, just let it dry naturally. Never use tableware polish, solvents and soap or frictional polishes and cleaners on the leather. Just use special leather cleaners. These cleaners will completely clean all spots and grease marks without leaving any marks.

To ensure the cleaning agent does not have any undesirable effects on the leather's color and appearance, first test it on a parts not in view.

You need to clean the leather surface once every few months. First dust the leather, then to clean and protect leather surface, use leather cleaners and protectors using a circular motion.

A smell of leather is natural in the first few months.

If possible, when the vehicle is parked, leave one of the windows slightly down. Prevent direct sunlight on the leather surface for long periods, as much as possible.

Do not use any types of wax on the leather surface since this will attract dust. The leather covers may be cleaned using a damp clean cloth. If the leather surface is very dirty, you can use a cotton cloth with the suds made by a shampoo solution to clean it and then dry it.

If as time passes, any signs of attrition or discoloration appears, apply to your Iran Khodro authorized representative to rectify it.

Care Of the Fabric Used in Inside Furnishings of the Vehicle*

This type of fabric, like any other, requires care to keep its beauty and durability. For this reason, any type of stain, whether from foodstuff, alcohol or liquids should be cleaned using a sponge and carpet shampoo. Never use tableware cleaners, solvents, soap or polish and especially abrasive cleaners on the fabric.



CAUTION

Clean any type of stain on the fabric, using only carpet shampoo and sponge.

*If equipped

5 TECHNICAL EMERGENCIES

TOWING	110	FUSES*	119
CHANGING WHEELS	112	MAINTENANCE & SERVICING OF BATTERY	133
CHANGING LAMPS	115	HANDLING METHOD IN A CASE OF LEAKAGE*	137

*If equipped

VEHICLE TRANSPORT

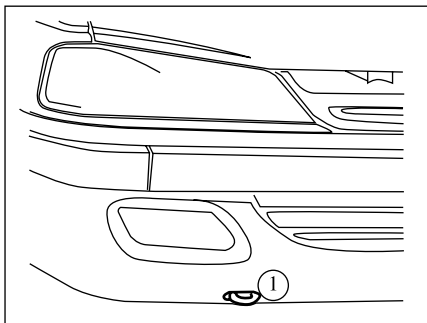

5

Front Towing Ring

Use the ring beneath the front bumper only to tow the car on 4 wheels.

Towing the car with a manual gear box (non-automatic)

Neutralize the gear and turn on the flashers.

Drive carefully and never exceed the speed limit of 50km/hr when being towed

Always keep the tow rope stretched by gently applying the brake as necessary. It avoids impact on the rope and its rupture.

- Get help from experienced persons to carry the car.

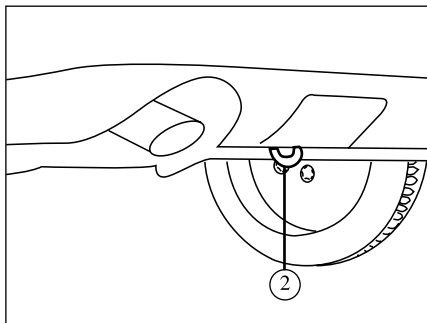

Rear Towing Ring

The rear ring should be used only to tow cars lighter or with the same weight.

Do not use the rings for suspending tows (on two wheels)



WARNING

- If the engine is off, the hydraulic Steering wheel and brake system, do not operate.
- The vehicle on tow should be always lighter than the towing vehicle.
- The towed vehicle should never have any passengers.
- Remember that the brake servo does not operate when the engine is off, and you need much generator force to operate on the brake pedal.
- Do not take out the start switch or turn it off when the vehicle is being towed on four wheels since this will cause the steering wheel to lock. It is recommended to place the switch in the A position.
- We recommend use of a sturdy and fixed bar when towing the vehicle. If using rope or cable (where it is legal), the towed vehicle should be able to brake (the engine could be turned on).
- Do not tow a vehicle that can not be moved and driven.
- To prevent damage to the vehicle, do not brake violently or speed up suddenly.
- At any rate it is recommended not to let the speed go over 25 km an hour.

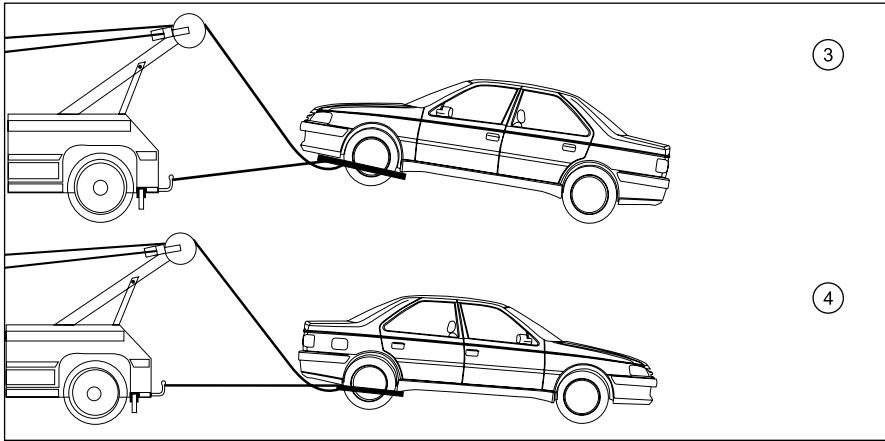

3

4

Transport by truck

This type of carrying is recommended to prevent any accident or damage.

Rear Towing

Avoid **suspension** towing on front wheels if possible. If it is necessary, tow it at least speed and short distances.

The steering should be locked when the wheels are completely ahead. Use supporting clamps or catches in addition to the steering lock.

Front Towing

The steering should be locked when the wheels are completely ahead. Use supporting clamps or catches in addition to the steering lock.

5



CAUTION

When the car is being towed from the front and moves on back wheels, make sure the handbrake operating on the rear wheels is released.

CHANGING WHEELS

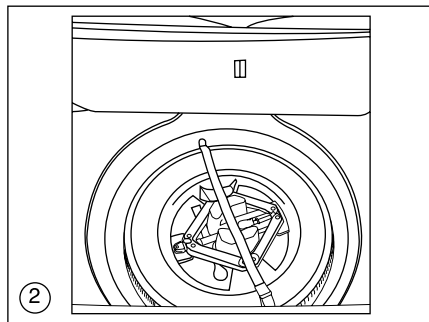
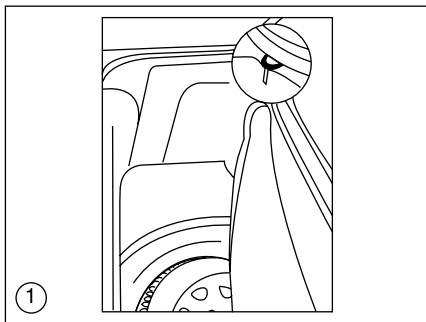

5

Changing the wheels

Stop the car on a hard and smooth surface, put the hand brake and shift the Gear lever to Gear one or reverse Gear and then intend to change the wheel.

Changing the reserve wheel

1- First, bring up the carpet covering the reserve wheel in the rear trunk and according to the sketch, hang it to the edge of the rear trunk. Then open the belt.

2- Removing the reserve wheel:

-Removing wheel spanner, jack and hubcap spanner from the foam cover of the reserve wheel.

-Removing reserve wheel from rear trunk.

3-Removing the wheel.

Removing the wheel

- Put the peak of the wheel spanner into the groove of the hubcap, against the tire air manifold and remove the hubcap.

- loosen the nuts of the wheel.
- locate the head of the jack in special position for use of jack, in the required side and raise the jack up. Then unscrew the nuts of the wheel completely and take out the wheel.

Wheel chains

The wheel chain can effect driver control on vehicle.

When using a wheel chain, pay attention to the following points:

- Do not drive at speeds more than 50 km/h.

If the speed of lower than 50 km/h has been denoted by the wheel chain manufacturer, consider the lower speed of driving as your criteria.

- Take caution at driving and drive with lowest speed as far as possible, while you're passing on obstacles, hurdles,

holes etc.

- Avoid equipping the spare tire with wheel chain; Because this can lead to damage to the spare tire as well as the vehicle.

- Use of the wheel chain for roads free of snow and ice, will cause damage to the tire and wheel chains.

- Use of the wheel chain in the vehicles equipped with Aluminum rings can cause scratches on the surfaces of the rings.

- In order to more safety of yourself and the vehicle; it's better to use winter tires instead of wheel chain.



WARNINGS

- Park your car on a smooth and hard surface which is not slippery (for example, do not park on ceramics) and if necessary use a barrier underneath the base of the jack and switch on the flashers (Emergency lights)

Put the hand brake and remove the gear from neutral. (Gear 1 or rear gear or in position P for automatic gear) Disembark the passengers and lead them to a place away from traffics.

- **Never** work under the vehicle when the only resting point is jack. It is only for the purpose of changing wheels.

- Always in order to change the wheels, choose a safe place away from traffics. Disembark the passengers and lead them to a place away from the vehicle.

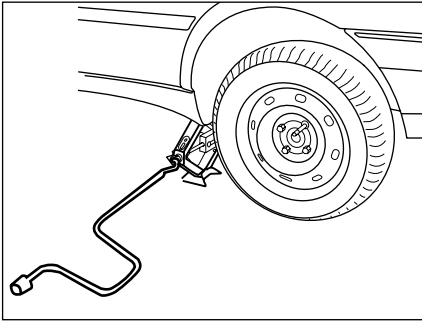

Inserting the spare wheel

- Put the reserve wheel in to its place properly and tighten the nuts with hands as much as possible.
- Lower down the jack and remove it from the place underneath of the car.
- Tighten the wheel nuts with wheel spanner completely.
- Fix the hubcap on the ring in such a way that air manifold of the tire comes out of the related groove. To fix tightly, hit the fringes of the hubcap strongly with palms of the hand.
- Put the flat tire (Punctured tire) in place of reserve tire in rear trunk.
- Put the Jack, wheel spanner and hubcap spanner on the foam cover and secure the wheel with belt.

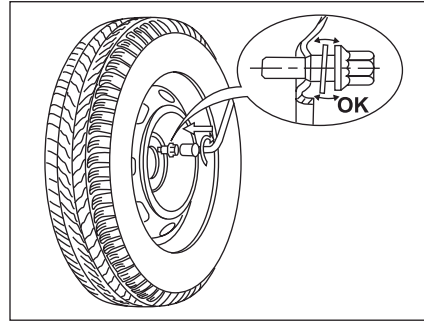

Inserting the steel type of spare wheel

Your vehicle is equipped with a steel type of spare wheel. At the time of replacing care must be obviously taken so as the screw washer not to touch the string. Spare wheel is tightened with conical shape of each screw

WARNINGS



- Jack is only used for changing the wheels only. Under no circumstances it should be used for other operations such as repairs or reaching underneath of the vehicle.
- If the life time of the reserve tire is over, take it to the one of the authorized repair shops, so that you can make sure about it's good conditions and safe usage.
- May be the air pressure in the reserve tire is not adequate. Therefore drive calmly and precautionary and as soon as possible check it's air pressure. Also check whether the nuts of the wheels are correctly secured and they are absolutely tight.
- Repair the punctured tire quickly so that in case of any requirements, you can fix it on your vehicle again.



Attention

On vehicles equipped with aluminium wheels:

- There are four screws in the Jack Box for installation of spare steel wheels.
 - Fifth wheel is a temporary wheel (to change in urgent situation and when one of the tires are punctured).
- So, due to the mismatch of tires and spare tire, there is no problem if the tire or the tire crown is different from the other aluminium ring tires.*

CHANGING WHEELS

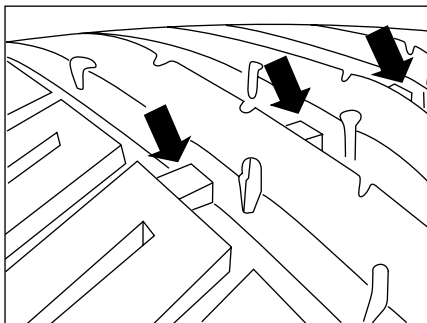

5

Tread wear indicator

The tires have molded-in tread wear indicators in the grooves. When the indicators appear on the tread surface, the remaining depth of the tread is 1.6 mm and the tire should be replaced.

Air pressure of the tires

Inspect your vehicle's tires at least once a month when the tires are cold. Under-inflation can cause heat which decreases the tires life. Over-inflation can cause negative effects on convenient driving.

Tire size:

Your vehicle's tire size is molded on its body such as following:

185/65 R 15, in which 185 is the width of the tire in mm, 65 is the ratio of the height to width of tire, R means Radial structure and 15 is the wheel diameter in inch.

Tire rotation

Front tires wear more than rear tires in front differential vehicles due to braking, driving and steering forces. To avoid uneven wear of your tires and to prolong their life, rotate the tires as follows every 10000 km driving:

Taking care of the tires

Inspect the treads and side wall of the tires to find out damages (especially cracks and node).

Puncture

Change the punctured tire and have it inspected before patching.

To avoid more possible damages to the tire, it should be repaired by an expert technician. Repair should be performed by expert technicians who accept full responsibility for the quality of the repair.



WARNINGS

Driving with the tires in which the air pressure has been reduced more than 20% of what has been recommended will cause the increase of fuel consumption and effects the vehicle dynamic and brings about the unexpected functional reduction of the vehicle.

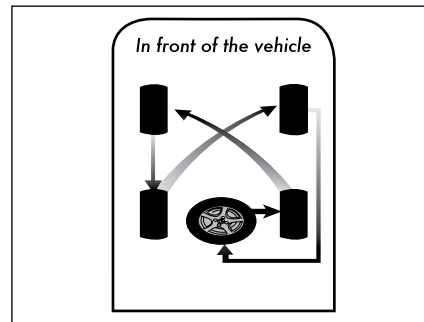

WARNINGS

-Damaged tires are very dangerous! Avoid driving with damages, worn and/or over-inflated tires.

-Use always same type and size radial tires for front and rear tires. Do not use tires with crisscross form. Your vehicle's wheels are not tubed, do not use tubed tires.

-Never drive with worn, punctured and not adjusted air pressure. Under-inflated tires are worn quickly and increase the fuel consumption and decrease the control on vehicle.

Driving with the tires in which the air pressure has been reduced more than 20% of what has been recommended in off roads, may cause damage and deformation of the rings. It will also increase the risk of attaching sands between rings and tires which brings about immediate depletion of tires result in accidents.

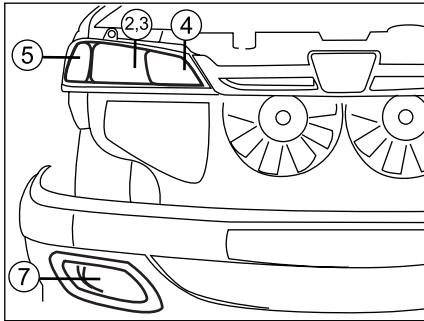

Changing the lamps

Front lights

In order to dismantle the front lights , it is necessary to dismantle the forward bumper and forward vent channel window first . Then by opening the light installation screws to the light socket frame, separate the light combination from the socket frame.



WARNING

For replacing the turn signal lamps, needed to open a large number of components. So, for this reason it is recommended refer to one of the dealers authorized for do that.

The bulbs are under vacuumed and, at the time of replacing may be broken and cause injuries.

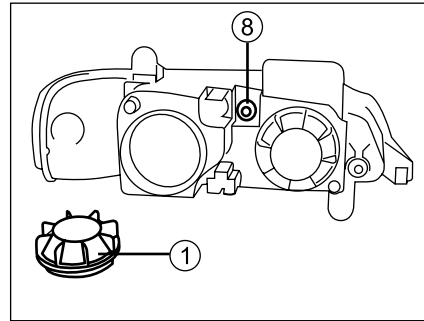

1-Front light bulbs

Turn the plastic covers behind the light, anticlockwise, until it gets separated. Then change the bulb.

2- Small lights of 5 watts

3- Main lights (Big), lower beam H7= 55 watts.

4- Main lights (Big), upper beam H7= 55 watts.

5-Front side lights

By releasing the Brushed Metal, open the lamp and then replace it.

Side light lamp of 21watts

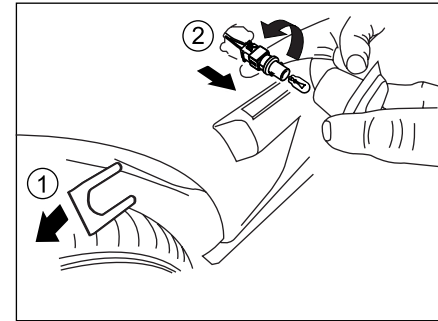

6-Side lights on the mud guards

- By separating the plastic pins on the bottom and screws available (within the limits of the tires), remove the mud shield.

- Pull-out brushed metal of the traffic lights which is sliding. (1)

- By rotating the traffic lights, remove it from its place. Rotate the lights counterclockwise to remove the bulb base. (2)

- change the bulb.

-side light lamp on the mud guard T8.4 = 4 watts, 12 volts.

7-Anti fog lights on the bumper

Remove the blue socket of the anti fog light. Change the bulb.

The front anti fog light H1= 55 watts, 12 volts.

8-Adjusting screws for front lights

CHANGING LAMPS

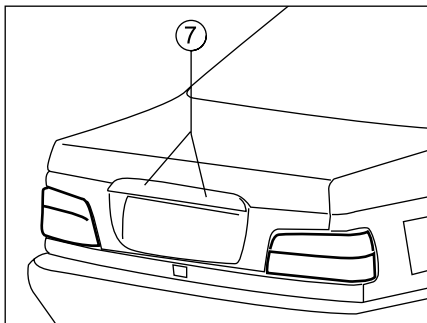

5

Changing the combination of lights at the back

- Remove the decorative frame of the rear light sockets from the rear trunk.
- Unscrew the holding nut of the frame for rear side light and change the combination of light.

Changing the bulbs for rear lights

- Unscrew the holding nut of the rear light from the rear trunk and take out the rear light frame, then change the side light bulbs.



WARNING

The bulbs are vacuumed and may break during changing and cause injuries.

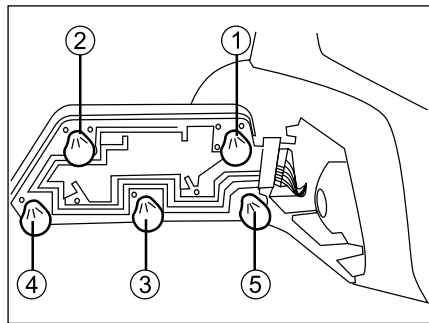

Change of lamp

Rear side lights

- 1-Side light lamp= **21 watts.**
 - 2-Reverse gear light lamp= **21 watts.**
 - 3-Light reflector-Small light lamp= **5 watts.**
 - 4-Rear anti fog light lamp= **21watts.**
 - 5-The brake light lamp=**21watts.**
 - 6-Small light lamp= **5watts.**
- All rear light lamps are changed through the rear trunk. To dismantle the frame of the lamp, first unscrew the nut of the frame and then change the fused bulb.
- 7-Vehicle number light lamp = **5 watts.**

Unscrew the plastic cap of the lamp and change the fused bulb.

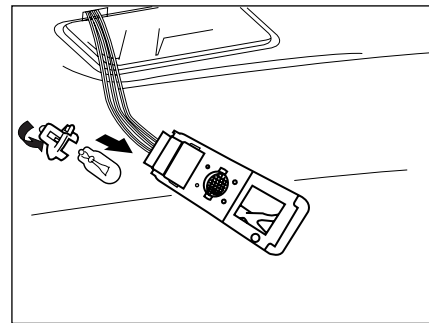

Front/Rear Ceiling Lights

- Enter a screwdriver into the slot, at the end of the lamp, and lever off the lamp, detach the lamp assembly from the console. Keep the lights assembly, and open the lamp base. Remove and replace the bulb ensure that solid foundation is in place. Then install lamp assembly in place.

It is recommended that always keep one set of required lamps, bulbs and fuses with you in the vehicle.

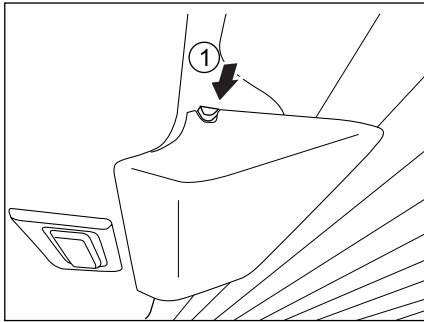

High brake lights (rear shelf) *

- Pull the side clamp downwards and, open the lamp assembly.(1)

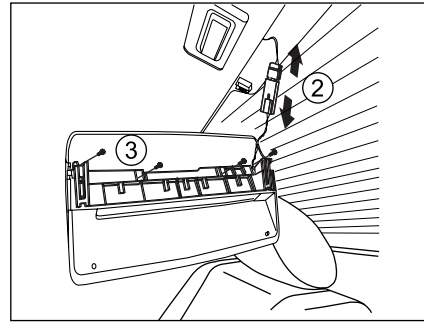

- Then detach the jack. (2)
- By opening the holding screws, replace the lamp assembly.(3)

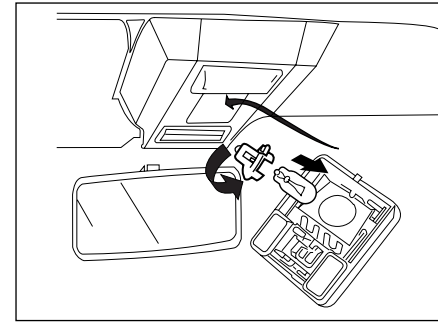

LED map reader (middle)

- For replacing LED map reader lamps, first, open the screws Decorative cantilever roof, remove the frame and then release sockets of LED map reader and rotate the bulb inside it in the opposite direction of clockwise and remove, then replace. After that, re-instal.

5



WARNING

The bulbs are under vacuumed and, at the time of replacing may be broken and cause injuries.

If equipped*

CHANGING LAMPS

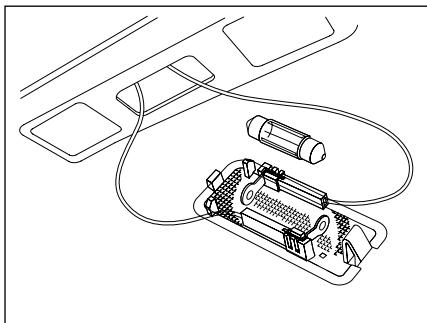

5

LED trunk

Insert carefully a screwdriver into the groove of the lights. Removing the talc, the lamp can be seen. Detach the lamps from both ends of your connection replace the bulb. Re-install the lights in place.

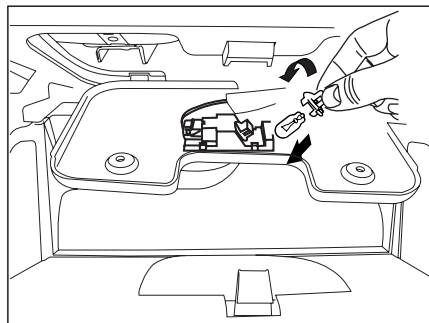

Dashboard lights

- First, by opening two bolts, open the frame of lights.
- Then by rotating the base of lamp anti clockwise open the base of lamp and replace it.

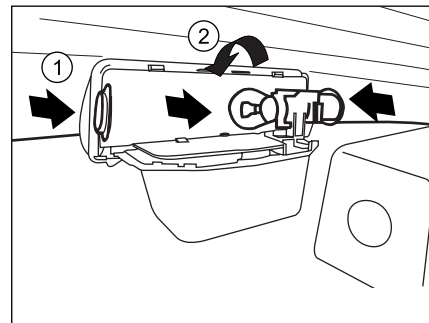

The third red light

- First, open the holding frame of lights by pressing two buttons on either side of the frame. (1)
- Then, by pressing the bulb inward and rotate it counterclockwise to open and replace the bulb. (2)



WARNING

The bulbs are under vacuumed and, at the time of replacing may be broken and cause injuries.

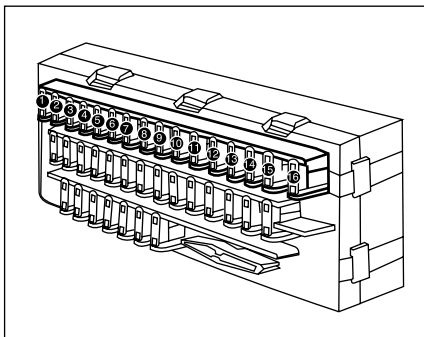

FUSES FUSE BOX

Fuse box is situated under the dashboard to the left hand side of the Driver which included six spare fuses plus special vise for changing fuses. To open the fuse box, pull the cover door of the fuse box forward.

1-F1 = 10 Amperes: Radio / CD player power supply after main switch

F1A = 10 Amperes: Radio / CD player continual power supply

2-F2 = 05 Amperes: Relay compressor cut - electricity after ceiling light timer switch - key has three versatile.

3-F3 = 15 Amperes: After the power switch modulator ABS - high speed fan relays.

4-F4 = 10 Amperes: Small LED rear right - Buzzer signal relay power-lighting.

5-F5 = 15 Amperes: Relay Fans - feeding after

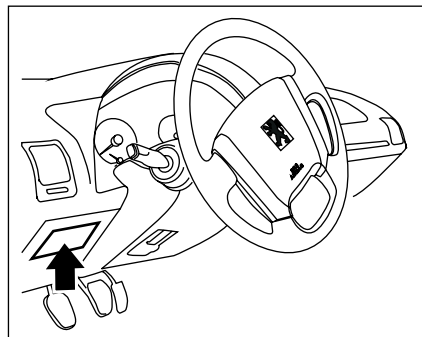

switch intelligent ventilation system.

6-F6 = 10 Amperes : Air bag power supply.

7-F7 = 20Amperes: Horn Relay-fog lamp-horn

8-F8 = SHUNT-Input shunt switches

9-F9 = Front small lights, Rear small lights left-Rear plaque light.

10-F10 = 30 Amperes: Rear window lifter - Window switches back lighting.

11-F11 = : 30 Amp. : MAIN FUSE related to front light- low and high beam lights- the relay front/rear fog lamp.

12-F12 = 10 Amperes: Reverse lights - rear obstacle warning unit - after the switch forward power amplifiers - feeding after room temperature sensor switch - switch power after DIAG - feeding after ABS alarm relay.

13-F13 = 30 Amperes: No consumption.

14-F14 = 30 Amperes: No consumption.

15-F15 = 15 Amperes: Power LED ceiling

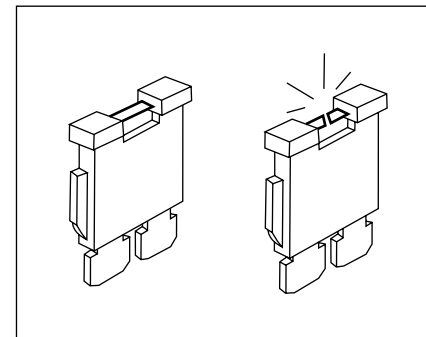

lights front and rear - power unit central locking - power folding mirror unit - electric permanent timers roof - lights trunk - relay ejector trunk.

16-F16 =20 Amperes: Lighter after switch power supply

F16A=20 Amperes: Lighter. continual power supply after main switch

5



CAUTION

Electric fuses are considered for all models of PEUGEOT, but may be some of them dose not have any usage in few models.

FUSES

Fuses:

17-F17 = 10 Amperes: Permanent power unit intelligent ventilation system - Memory radio.

18-F18 = 10 Amperes: Rear fog lamp

19-F19 = 10 Amperes: Panel lighting - Front lighting Amp - Brightness panel radio keys - Lighting control system on the steering wheel (MFC) - Lighter lighting - Lighting controllers, electric mirrors.

20-F20 = 30 Amperes: Power driver seat.

21-F21 = 30 Amperes: Smart fan ventilation system.

22-F22 = 20 Amperes: Power passenger seat.

23-F23 = 15 Amperes: No consumption.

24-F24 = 30 Amperes: Motor for Wipers - Wiper lever - Power unit glass wiper and washer pump

25-F25 = 15 Amperes: Forward permanent power amplifiers - a permanent power DIAG.

26-F26 = 15 Amperes: Flash unit - a permanent electricity panel radio buttons

27-F27 = 30 Amperes: Rear glass heater - Side mirrors heater.

28-F28 = 15 Amperes: Brake lights - front window lift relay - panel power after switch keys radio.

29-F29 = 30 Amperes: Window lifter front - Lighting glass front lift keys.

30-F30 = 15 Amperes: Map reading light - Steering indicator circuit power supply - The power relay - Glove compartment light - Rear window lifter relay - Relay locking rear lift glass child - Lighting rear lift glass - Automatic window lifter unit - Electric mirror.

31-F31 = Spare fuses

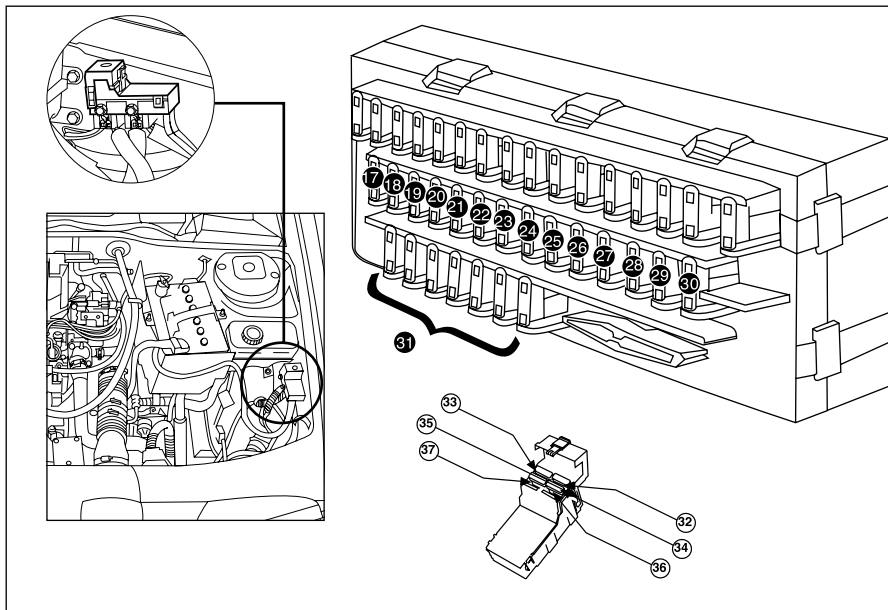

Fuses inside engine space:

32-F32 = 30 Amperes: Fan for engine.

33-F33 = 30 Amperes: Fan for engine.

34-F34 = 30 Amperes: Spare fuse

35-F35 = 30 Amperes: Spare fuse.

36-F36 = Short circuit connection - Power supply for fuse box and main switch.

37-F37 = Short circuit connection - Power supply for fusebox.



WARNING

- Always replace a faulty fuse with a fuse of the same rating (amperage).
- Improper use of the power outlet can cause damage. Usage of fuse with the amperage more than what is needed; make the circuit overheated and probable fire.

Fuse operation	Fuse ampere	fuse
Radio (power supply after switch)	10 A	F1
Radio (direct power supply from battery)	10 A	F1A
Lighter (direct power supply from battery)	20 A	F2
Lighter (power supply after switch)	20 A	F2A
Reserve 5	30 A	F3
Rear window heater button, step 2 switch	15 A	F4
High speed fan, heater relay, heater panel	15 A	F5
Windshield wiper engine, Windshield wiper relay, washer pump	30 A	F6
Map reading light, dashboard light, indicator light, power mirror light, glass lifter light	15 A	F7
Shent	40 A	F8
Reserve 8	30/15 A	F9
Heater fan	30 A	F10
Tail lights switches	10 A	F11
Reserve 4	10 A	F12
Reserve 3	30 A	F13
Front ampere, digital clock, break lights	15 A	F14
ABS break	10 A	F15
Reserve 6	10 A	F16
Doors lock button	30 A	F17
Front ampere warning lights, rear gear light, tachometer, oil level adjustment light	10 A	F18
Roof light timer, fuel ampere light, temperature sensor light	5 A	F19
ABS break	15 A	F20
Reserve 2	10 A	F21
Rheostat (ampere and button backlight adjustment)	10 A	F22
Reserve 7	10 A	F23
Reserve 1	15 A	F24
Flasher	15 A	F25
Mirrors open/close	10 A	F26
Horn	20 A	F27
Mirrors heater, right rear glass lifter button	30 A	F28
Left door switch, front glass lifter	30 A	F29
Roof light, radio, digital clock, door side light, trunk light, central lock receiver	15 A	F30
Central lock control box	15 A	F31
Reserve 9	5 A	F32
Rear fog light	10 A	F33
ABS brake	30 A	F34
Front fog light	30 A	F35
Rear glass lifter	30 A	F36
Passing lights, low/high beam	30 A	F37

*If equipped

Junction box*

Fuses are simple connections which cut the electricity when necessary, in order to protect the electrical parts. When an electrical part is broken down, its protective fuse may be blowout.

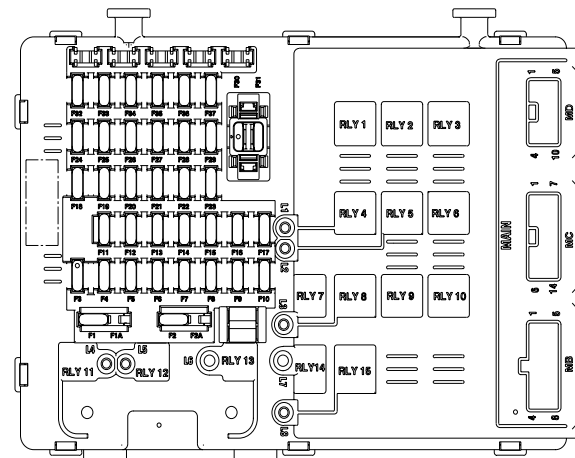

WARNING

Any modification or changes in the fuel supply system (electronic control unit, wiring, fuel circuit, injector, protective covers, etc.) due to the dangers that may threaten you is strictly forbidden (except by specialists in network services sales).

FUSES

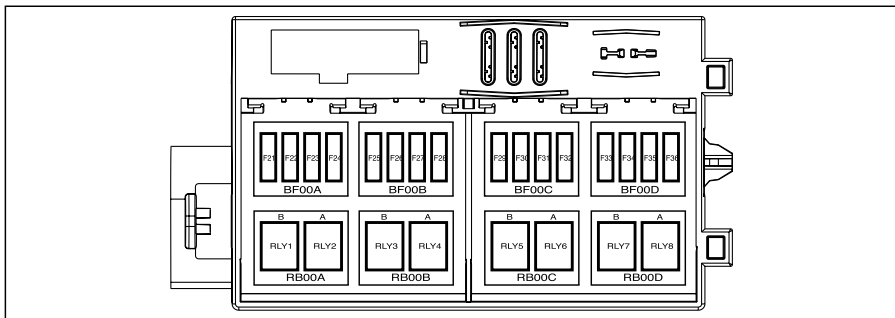

Fuses guide table (cabin)

5

Fuse No.	Rating	Fuses function
F21	20A	Electric Seat Supply
F22	10A	Main switch supply (position 2) air bag unit and air conditioning system
F23	10A	Main switch supply (position 1) lighter
F24	10A	Main switch supply - position 1 (motivation of heater relay · Radio, brake light, front node, central node and instrument panel), Motivation of Glass Heater Relay
F25	10A	Radio permanent supply
F26	20A	Central node supply
F27	20A	Central node supply
F28	30A	Central node supply and motivation of rear door motive relay
F29	30A	Rear Lifting Window
F30	30A	Central node supply (Front lifting window)
F31	30A	Rear window heater
F32	30A	Heater fan supply
F33	30A	Engine ignition
F34	10A	Main switch supply (position 2) immobilizer, diagnostic connector, instrument panel, cooler gas pressure sensor, engine unit
F35	5A	Main switch supply (position 2), Anti-brake system (ABS)
F36	10A	Immobilizer permanent supply, diagnostic connector, instrument panel

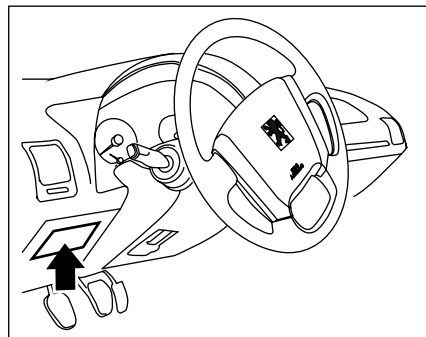

FUSE BOX AND DASHBOARD RELAY*

The fuse box is located under the dashboard on the left. To open, pull the fuse box cover to the front.

Relay No.	Relay Function	Rating - type
RLY1	----	----
RLY2	Trunk Lid Electric Actuator	Contact 1 - 30A
RLY3	Mirrors and rear window heater	Contact 1 - 30A
RLY4	Ventilation Fan Relay	Contact 1 - 30A
RLY5	Rear Lifting Window (Left)	Contact 2 - 30A
RLY6	Rear Lifting Window (Left)	Contact 2 - 30A
RLY7	Rear Lifting Window (Right)	Contact 2 - 30A
RLY8	Rear Lifting Window (Right)	Contact 2 - 30A

*If installed in your car

Fuses Guide Table *

Fuse No.	Rating	Fuses function
1	40A	Electric supply for ignition switch
2	30A	Relay switch for fog lamp/horn
3	40A	BCM Inside systems electric connection supply
4	30A	BCM Inside systems electric connection supply
5	40A	Fan (High speed)
6	30A	Fan (Low speed)
7	30A	Brake (ABS)
8	40A	Brake (ABS)
9	----	Reserve
10	20A	Front node supply
11	15A	Front node supply
12	30A	Front/Rear Windshield Wiper and relay for windshield washer pump
13	----	Spare
14	30A	Double relay supply
15	10A	Fuel pump supply
16	10A	Engine unit supply
17	----	Spare
18	----	Spare
19	----	Spare
20	----	Spare

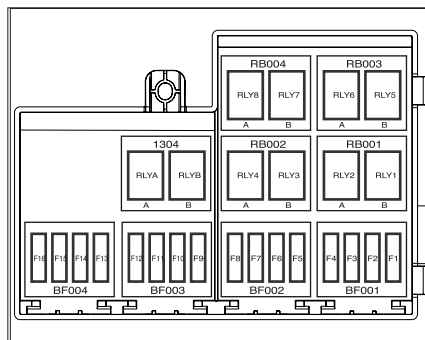

Relays Guide Table *

Relay No.	Relay Function	Rating - type
RLYa	Relay switch for engine control	30A-1Contact
RLYb	Relay switch for fuel pump	30A-1Contact
RLY1	Relay switch for fog lamp	30A-1Contact
RLY2	Relay switch for horn	30A-1Contact
RLY3	Relay switch for windshield wiper	30A-2Contact
RLY4	Relay switch for windshield wiper	30A-2Contact
RLY5	Relay switch for fan (high speed)	40A-1Contact
RLY6	Relay switch for fan (low speed)	30A-1Contact
RLY7	Relay for fan	30A-2Contact
RLY8	Relay for windshield washer pump	30A-1Contact

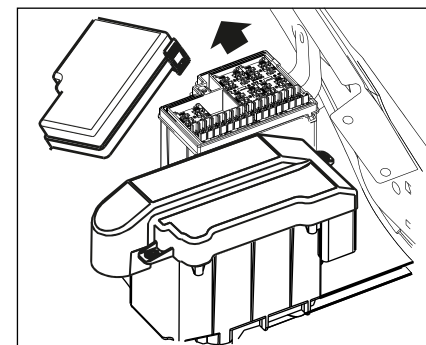

Engine Compartment Fuse box *

Fuse box is in the right part of the engine compartment. To access the fuse located in the engine compartment, unclip the fuse box cover. Close the fuse box cover carefully when you have finished. Vehicle owner shall not tamper fuse connection. Any problem in this part should be checked by authorized experts.

5

*If installed in your car

FUSES

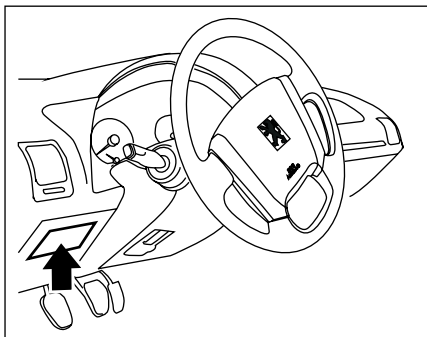

5 Fuse Box and Relay inside the dashboard CEC*

The location of the fuse box is under the left air valve.

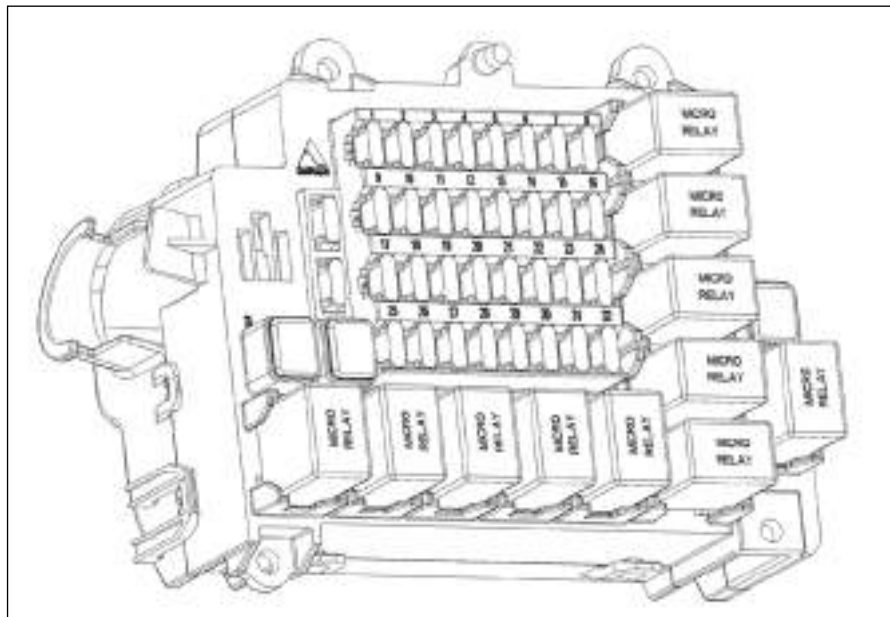

*If equipped

Fuse Box Relays inside the dashboard CEC*			
Relay Operation	Type of Relay	Relay Color	Relay
Relay for Ventilation Fan	HC Micro 4P (12V/35A)	Brown	R1
Power Relays for Shock Sensor and Motion Sensor (Option) 1	Micro 5P (12V/20A/10A)	Grey	* R2
Relay for Power Management	HC Micro 4P (12V/35A)	Brown	R3
Glass Heater Relay	Micro 4P (12V/20A)	Green	R4
Wiper Relay	Micro 5P (12V/20A/10A)	Grey	R5
-----	-----	-----	R6
Relay for the rear window lifter	HC Micro 4P (12V/35A)	Brown	R7
Relay for the front window lifter	HC Micro 4P (12V/35A)	Brown	R8
Relay for opening the Trunk	Micro 4P (12V/20A)	Green	R9
Relay for unlocking the Central Locking	Micro 5P (12V/20A/10A)	Grey	R10
Relay for locking the Central Locking	Micro 5P (12V/20A/10A)	Grey	R11

1- The relay must be connected if shock sensor and motion sensor to be used.

*If equipped

FUSES

Fuse Box and Relay inside the Dashboard CEC*

Fuse Box Fuses inside the dashboard			
Fuse	Fuse Ampere	Type of Fuse	Operation
F1	20	Mini	Cooler Gas Pressure Switch 3 phase AC to ECU
F2	5	Mini	Fans Relay Coil Power
			Relays (Air Compressor - Fan Motor) Coil Power Fuse Box inside the Engine. The input of the glass heater key and the TCU automatic gearbox
F3	-----	-----	-----
F4	-----	-----	-----
F5	5	Mini	Backlight Lighter
			Backlight Heater Button
			Backlight Flasher Switch
			Backlight CNG Switch
			Backlight Radio
			Backlit Front Panel
			Fans Backlight
			Backlit Hours
			Backlight Trunk Ejector Button
			Small Light CEC
			Mirrors Regulator Keys Backlight
			Central Locking button on the front panel backlight
			Backlit keyboard shortcuts locking up the rear glass

Fuse Box Fuses inside the dashboard			
Fuse	Fuse Ampere	Type of Fuse	Operation
F6	10	Mini	Front Small Light
			Rear Small Light
			Plate Light
F7	10	Mini	AIR BAG Power
F8	5	Mini	Front Panel Power (Steps 2,3)
			Immobilizer Power (Steps 2,3)
			A/C Switchboard (Steps 2,3)
			Power to DIAG (Steps 2,3)
			Power (Step 2 and 3) for ECU and, TCU automatic gearbox
			Power (Steps 2,3) for CEC ABS Power Module (Steps 2,3)
F9	20	Mini	Low-speed Wiper Switch
			High-speed Wiper Switch
			Glass Washer Pump
			Wiper Relay Power
F10	5	Mini	CEC Power (Steps 1, 2)
			Power to Trunk Ejector Switch (Steps 1,2)
			Right/Left Indicator Switchboard (Steps 1,2)
			Power Hours (Steps 1,2)
			Zero Crossing Electric Wiper Motor (Steps 1,2)

*If equipped

Fuse Box and Relay inside the Dashboard CEC*

Fuse Box Fuses inside the dashboard			
Fuse	Fuse Ampere	Type of Fuse	Operation
F11	10	Mini	Rear Gear Lamp
			Driver-side power window switch
			Power Side Mirrors
F12	10	Mini	Power Brake Switch
F13	-----	-----	-----
F14	5	Mini	Constant Power Ceiling Light
			Dashboard inside lamp
			Trunk Lamp
F15	20	Mini	Map Reading Lamp
			Lighter
F16	10	Mini	Radio
F17	-----	Mini	-----
F18	5	Mini	Ceiling Light Control Mode
F19	5	Mini	Front Fog Lamp Button
F20	15	Mini	Up Light
F21	15	Mini	Low Light
F22	10	Mini	Rear Fog Lamp
F23	5	Mini	Side Mirrors Heater
F24	30	Mini	Rear Glass Heater

- 1- If the installation of Relay R2, the fuse must be installed.
- 2- If the installation of Company Siren, the fuse must be installed.

Fuse Box Fuses inside the dashboard			
Fuse	Fuse Ampere	Type of Fuse	Operation
F25	30	Mini	Electric Actuator Driver Side Door
			Driving Power Right Front Door
			Rear Door Electric Actuator (Driver Side)
			Driving Power Rear Right Door
			Driving Electric Fuel Door
F26	-----	-----	Driving Power Trunk Lid

F27	5	Mini	All electrical relay coil inside the fuse box inside the cabin
			Horn Button
F28	20	Mini	Instrument Panel Battery Power
			Power CEC
F29	5	Mini	Central Switch Board
			Power Hour
			Battery Power for DIAG
			CEC Battery Power
F30	10	Mini	Memory Power Radio
*F31	5	Mini	Optical and Shock Sensor Power (Option) 1
**F32	5	Mini	Alarm Power (Option) 2
F33	40	J-Case	Ventilation Fan
F34	40	J-Case	Front Windows Lifter Power
			Backlit Keyboard shortcuts above the Front Glass
F35	40	J-Case	Rear Windows Lifter Power
			Backlit Keyboard shortcuts above the Rear Glass
F	5	Mini	Spare
F	10	Mini	Spare

5

*If equipped

FUSES

CEC Integration System*

1- Ceiling Light

- If one of the doors open ceiling light lights.
- Ceiling light stays on about 40 seconds if the entire doors close and the ignition switch are not opened.
- Ceiling lights stays on about 5 minutes if a door opens.
- If one of doors or trunk lid or bonnet open and the car is moving, ceiling lamp flashes for a while.
- In case of opening the doors by remote control, ceiling lamp lights.
- Locking the doors with remote control or switch, if ceiling lamp lights will be turned off dimmer.
- If auto detection is activated via remote control, ceiling light will stay lit for a while.

2- Ejector Trunk Key

- When the switch is on, if the key is pressed for 1.5 seconds the trunk door is opened.
- If the car is moving and the key is pressed the trunk door is not opened.

3- Central Key:

- All the doors and trunk lid and bonnet if closed, can be locked/unlocked by key.
- All the doors and trunk lid and bonnet if closed, can be locked/unlocked by the

remote control.

- All the doors and trunk lid and bonnet if closed, can be locked/unlocked by the central key on dashboard.
- If one of doors or trunk lid or bonnet opens if you are running one of the top three states (for locking) the doors are locked once and immediately opens.
- When locking the doors with the remote control blinker blinks once.
- When locking the doors with the remote control if one of the doors or the trunk lid or the bonnet is open, the lock operation is not completed successfully, but the flasher flashes 4 times slow.
- When unlocking the doors with the remote control flasher flashes 5 times fast.
- Car Finder: When the car is locked with the remote control if the key to lock is pressed on the remote control again, the flasher flashed approximately 10 seconds fast.
- If in a short space of time the doors lock/unlock by the central key repeatedly, the central key disables for 20 seconds.
- If enabled option to lock automatically, when vehicle speed is above 20km/h, doors automatically lock and when the car is turned off the doors automatically unlock (If press and hold the central

locking key for approximately 5 seconds, by alarming and flashing LED Display 3 times (this option is disabled and re-enabled with repeated practice).

- If the doors are locked LED Display on central locking button stays light continuously and if the doors are open the LED Display will be turned off.

4- Windshield wiper

- Wiper timer mode 2 is optional by the DIAG (Diagnostic):
 - Timer with fixed time
 - Timer variable-speed out

5- Flasher:

- If the flash automatically by the DIAG option is enabled, when the vehicle speed is above 80km/h during sudden braking car blinker blinks a few times.
- If the option is activated by the DIAG when you open one of the doors, when the ignition switch is on and one of the doors is opened, blinker blinks for about 15 seconds fast.

6- LEDs on the front panel door open

- When ignition switch and one of the doors is open, door open indicator on the front panel will be illuminated and if the vehicle speed is above 20 km/h this indicator flashes.

*If equipped

7- Power the rear and front glass lifters

• When the ignition switch is closed, front and rear glass can be raised and lowered almost up to 30 seconds. It should be noted at this time the driver-side auto glass will not work.

8- Rear and Side Mirrors Heater

• Only when the car is on the glass heater will work.
 • When the glass heater is activated automatically will turn off approximately 12 minutes later.

9- Power Management

• Power manager can control and provide power of the following:
 - ceiling light, radio, cigarettes lighter, the dashboard light, trunk light.
 • If ignition switch is on but the car off, approximately after 15 minutes the power of these parts is disconnected.
 • If the ignition switch is closes, approximately after 7 minutes the power of these parts is disconnected.
 • If the car is locked with the remote control, the power of these parts is disconnected after a few seconds.
 • If open the car with remote control, or open one of the doors, the power of these components is immediately connected.
 • If the car navigation system of the remote control activate, the power

of these devices will be activated immediately.

• Note: If the vehicle battery is weak, electricity of all these parts will be cut.

10- ABS/EBD Alarm

11- Diagnostic System

Failure of all the different parts of the relays and the output for followings is recognizable by the DIAG:

- Central Locking
- Trunk Lid Ejector Button
- Rear glass heater and Mirrors
- Power Relay for Front Windows
- Power Relay for Rear Windows
- Relay for Wiper
- Relay for Power Management
- Left Indicator
- Right Indicator
- Ceiling Light
- Siren

12- Anti-theft *

• Optional alarm system by diagnostic device (DIAG) and the following method is enabled:
 • However, the following method can be used to enable or disable the alarm system:
 • 2 times the starter switch is opened and closed, and the case is closed. Now switch on the remote control is pressed 2 times. The alarm once activated, resulting in the alarm system will be

activated. If this is a repeat, alarm system is deactivated and the alarm will sound 2 times.

- Ability to install motion and shock sensors is possible.
- Ability to select the horn or siren for alarm system, by placing in F11, F12 fuse in the fuse box inside the engine is possible.
- When you lock the car with the remote control, siren will sound once and antitheft system is activated.
- When opening the car by remote control, siren will sound 2 times and the antitheft system is deactivated.
- When you enable auto-detecting , siren will sound 3 times.
- In case of activating each of the following, the siren , flasher and ceiling light are enabled:
 - Motion Sensor
 - Shock Sensor
 - A Car Door
 - The key to open the car doors
 - Trunk Lid Door opens
 - Bonnet opens

If for some reason the alarm is activated if the lock or unlock button on the remote control is pressed again the sound of sirens and flash stops and runs to lock the door.

*If equipped

FUSES

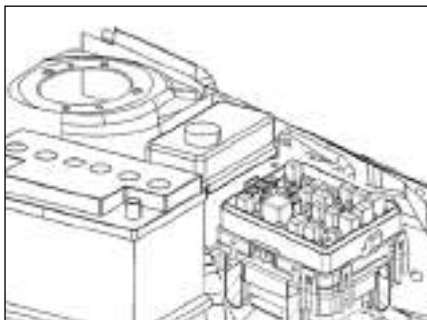

5

CEC Fuse Box for Relay inside the Engine*

CEC Fuses in the Fuse Box inside the Engine *

Fuse	Fuse Amper	Type of Fuse	Operation
F1	10	Mini	Electric Fuel Pump
F2	40	J-Case	ABS1 Power
F3	30	J-Case	ABS 2 Power
F4	50	J-Case	Battery Power for AA and CC Ignition Switch
F5	50	J-Case	Battery Power for kk Ignition Switch
F6	50	J-Case	Battery Power for all relays and fuses inside the fuse box inside dashboard
F7	40	J-Case	Battery Power for all relays and fuses inside the fuse box inside dashboard and Indicator Lever Inlet Power and relay power for power management and ECU power
F8	40	J-Case	Engine Injector
			Canister Solenoid Valve
			Speed Sensor
			Ignition Coil
			Camshaft Sensor (Camshaft Sensor)
F9	-----	-----	-----
F10	5	Mini	Bobbin Power Relays for Fuse Box inside the Engien
F11**	5	Mini	Horn instead of Alarm (Option)
F12**	5	Mini	Alarm (Option)
F13	15	Mini	Front Fog Lamp
F14	20	Mini	Horn
F15	-----	-----	-----
F16	-----	-----	-----

**Note: Only one of these fuses (F11, F12) should be located in its place.

*If equipped

CEC Fuses in the Fuse Box inside the Engine *

Fuse	Fuse Amper	Type of Fuse	Operation
F17	10	Mini	Heater Gas Valve
F18	10	Mini	Oxygen Sensor
F19	30	J-Case	High Speed Engine Fan
F20	30	J-Case	Low Speed Engine Fan
F21	-----	-----	-----
F22	10	Mini	Cooler Compressor Clutch
F23	5	Mini	Bobbin Power Relays for (Cooler Compressor - Engine Fan)
F24	20	Mini	Battery Power for ECU
F	15	Mini	Spare
F	20	Mini	Spare

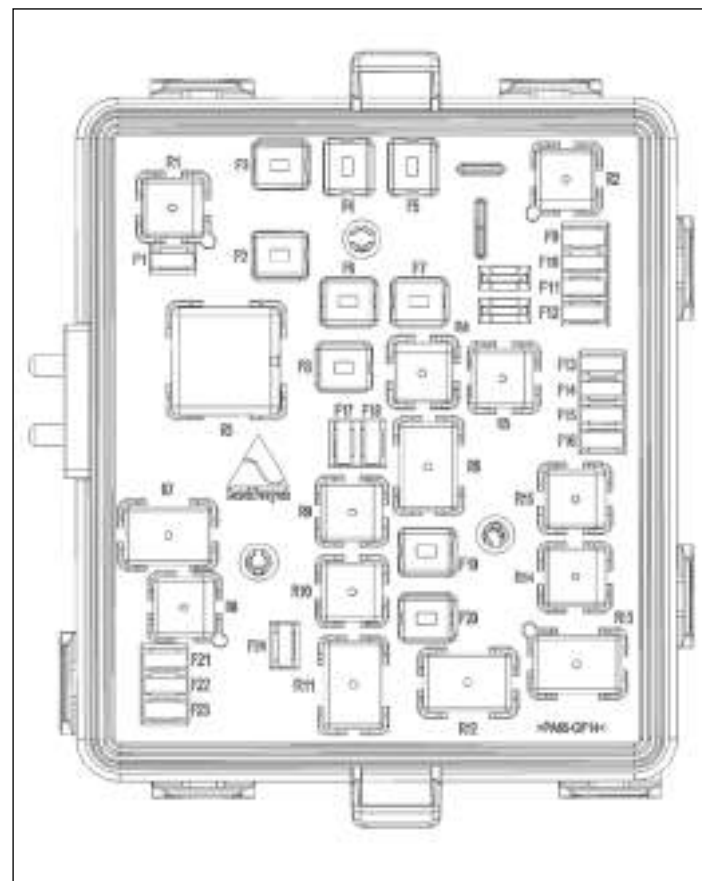

5

*If equipped

FUSES

Fuse Box and CEC Relay inside the Engine Compartment*

Relays in the Fuse Box inside the Engine

Relay	Relay color	Type of Relay	Relay Operation
RL1	Black	Ultra Micro 4P (12V/20A)	Relay for Fuel Pump
RL2	Black	Ultra Micro 4P (12V/20A)	-----
RL3	Light Grey	Mini 4P (12V/40A)	Double Relay
RL4	Black	Ultra Micro 4P (12V/20A)	Relay for Front Fog Lamp
RL5	Black	Ultra Micro 4P (12V/20A)	Relay for Horn
RL6	Black	HC Micro 5P (12V/35A/20A)	Relay 3 for Engine Fan
RL7	Brown	HC Micro 4P (12V/35A)	-----
RL8	Black	Ultra Micro 4P(12V/20A)	-----
RL9	Black	Ultra Micro 4P(12V/20A)	-----
RL10	Black	Ultra Micro 4P(12V/20A)	-----
RL11	Grey	Micro 5P (12V/20A/10A)	Relay for Cooler Compressor Clutch
RL12	Black	HC Micro 5P (12V/35A/20A)	Relay 1 for Engine Fan
RL13	Black	HC Micro 5P (12V/35A/20A)	Relay 2 for Engine Fan
RL14	Black	Ultra Micro 4P (12V/20A)	-----
RL15	Black	Ultra Micro 4P (12V/20A)	-----

5

*If equipped

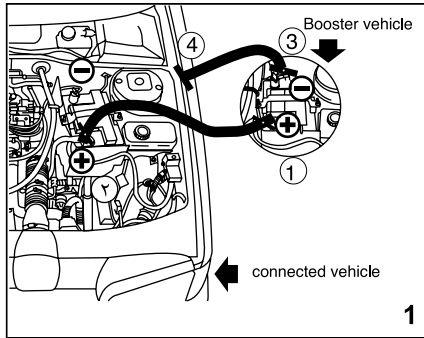

Emergency Charging the Battery

If your vehicle does not start due to the discharged or poor battery, do as following orders:

A) Battery to battery connection (using auxiliary vehicle)

1) Check both vehicle to have 12 Volt electrical system. If you do not observe this point, your vehicle wiring system may be damaged which is not under coverage of the guarantee.

2) Bring two vehicle as close as possible to each other but there should be not contact between them.

If you do not observe this, short circuit

will be established which cause damages to the vehicle wiring which is not under coverage of the guarantee.

3) Switch off all vehicle's electrical equipments (audio system, heating system, etc.). switch off the auxiliary vehicle. Check both vehicles to be in freewheel position. (manual gearbox) and P or N mode (automatic gearbox)

Apply both hand brakes of the two vehicles, otherwise there may be damages to the electrical equipments which are not covered by guarantee.

4) Open both engine cover and identify the positive and negative poles of the both batteries. Use flashlight or similar lighting instrument if it is dark.

5) Prepare two battery to battery cables (proper thickness and free from damages). Battery to battery cables are usually two thick red and black cables. Attach end of the one the cables to the positive pole of the auxiliary battery and its other end to positive pole of the discharged battery.

6) Then attach one end of the other cable to the negative pole of the auxiliary battery and its other end to the a point of receiver vehicle body which is not covered by

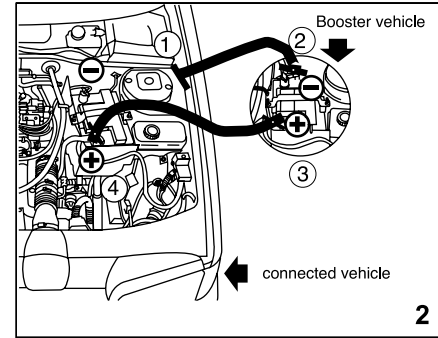

paint (such as engine mount). Ensure the connected cables are away from gasoline pipes, brake and rotary parts of the both engines.

7) Switch on the auxiliary vehicle and wait for a few minutes to have engine in idle speed.

8) Then start the receiver vehicle (discharge battery). Wait for a few minutes to have its engine in idle speed.

9) Disconnect the cables as figure (2)

BATTERY CARE & MAINTENANCE

B) Charging battery by charger

You should first dismantle the battery. Do as follows:

- Disconnect negative cable first.
 - Then disconnect positive cable;
 - Then disconnect the clamp of the battery and dismantle the battery from vehicle-
- Take the battery to the battery service center to be inspected by a pertinent expert. Please note followings:
- Check the battery poles and clamps of the battery cables to be clean. Open them and clean the sulfated residue on the cables.
 - Never disconnect the cables from battery when the engine is running.
 - Never charge the battery without disconnecting the cables.
 - When the vehicle is not going to work for long period (one month or more), disconnect the battery cables.



CAUTION

Final voltage of the 12 volt charged battery will be equal to 14.10 -14.40.

-Ensure the voltage of both battery to be same (12 Volt) when using auxiliary battery. Both connection cables should have insulated clamps suitable for using with 12 Volt batteries.

-If you are not going to use your vehicle for a long time, disconnect the battery cables. Charge the battery every 4 months.

-Since the vehicle start is 12 Volt, if you use a 24 Volt battery or two 12 Volt battery, your vehicle's electrical systems will be damages. So be sure you use a 12 Volt battery as auxiliary battery.

The positive cable shoe (red cable) must be always connected to the positive pole of the battery .To avoid the damage to the alternator avoid disconnecting it from the battery.



WARNING

In normal situation, batteries produce flammable Hydrogen gas which may cause explosion and serious injuries. Keep flames and sparks away from the engine compartment.

- Be careful when working near the moving parts of the engine.
- Use flashlight and/or similar lighting device in dark and never use matches and/or lighter.
- To switch on the engine by battery to battery method do in the mentioned order, otherwise it may cause firing, explosion and/or other damages to the vehicle.
- Keep the battery away from children.

Battery Care & Maintenance

- A) Always keep the battery case clean.
- B) To prevent the poles from becoming sulfated, cover them in industrial Vaseline or grease.
- C) The electrolyte level in the battery should always be kept the same. To do that, the battery electrolyte level should be checked at least once every 15 days and if the level drops, to recover it by adding only distilled water. Addition of other liquids such as industrial water, sulfuric acid and.... will inflict irrecoverable damage to the battery. If in this case, water evaporation volume is more than it should be, the vehicle should be taken to an authorized representative to be checked. In addition, prevent the battery cells from being left without electrolyte. Since its negative plates will synthesize with the oxygen in the air in a short time and the positive plates will also become sulfated and ultimately the battery will become useless.



CAUTION

In case of disconnecting or changing the battery and E.C.U, the vehicle's engine should be adjusted in one of the authorized dealer of Iran Khodro by pertinent turner. Never start your machine if the battery appears to be frozen. Make sure the voltage of both batteries to be equal (12 V). Leads should have insulated clamps which are suitable for being used with 12 Volt batteries. Do not disconnect the cables of the flat battery during jump start. Never connect the positive (+) terminal of the battery to the negative (-) terminal. Make sure to keep the jump leads away from moving parts of the engine. Do not install non-standard electrical accessories to your vehicle. This may cause damages to your vehicle's electrical system and battery which are not covered by Guarantee. Your vehicle should not be started by pushing. This starting method could result in cam belt and serious damages to your vehicles electronic systems which are not covered by Guarantee.

BATTERY CARE & MAINTENANCE

Battery Safety Tips

- Do not bang on the battery poles.
- Prevent short-circuiting of the positive and negative poles with each other.
- Never charge the battery more than the permissible level, since it will damage the battery panels and reduce battery performance and life.
- Ensure the holes made on the battery cover bolt are open otherwise the battery will explode due to the accumulation of gases produced.
- The battery in its place should be tightly installed since strong blows and jolts will damage it.
- Do not keep a charged battery under any circumstances since the battery plates will become sulfated and the battery useless.
- Since producing sparks or bringing flames near the battery will cause battery explosion (due to the hydrogen and oxygen produced), producing such conditions

should seriously be refrained from.

- It is recommended not to add any chemical stuff such as battery tablets, battery vitamins and... to the battery's electrolyte.
- To prevent risk of short circuits, when installing the battery on the vehicle, first connect the positive pole's cable and then the negative pole's cable and when taking the battery out, do this in reverse order (first the negative cable, then the positive cable).
- Ensure that the vehicle alternator and voltage regulator are working properly.
- Do not add additional electrical equipment to the vehicle without considering the battery capacity.
- If according to the authorized representative's technical expert's opinion, the battery has not been used properly, or proper service and maintenance for it has not been done or battery breakdown is due to a long period of inaction and non-usage, the vehicle battery will not be eligible under the guarantee.



WARNING

Over usage of the battery may cause firing in vehicle. So insure the electrolyte level to be above minimum line.

HANDLING METHOD IN CASE OF GAS LEAKAGE

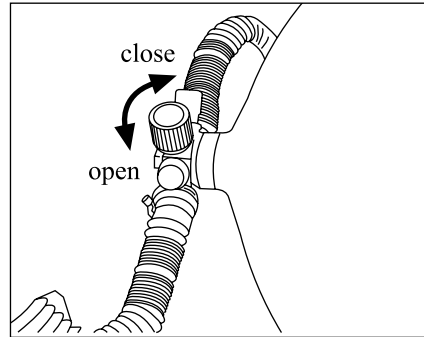
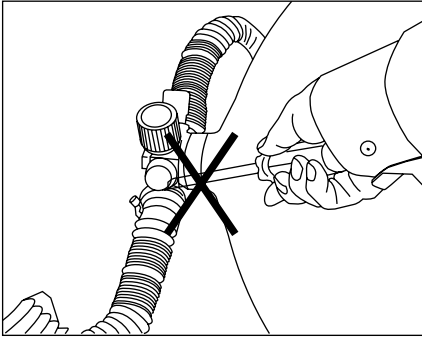

Handling Method in Case of Gas Leakage*

Although numerous safety precautions have been taken into account within the gas system, it is still important to bear in mind the following points:

- Inspect everyday your car for gas leakage.
- Any gas leakage from high pressure fittings and in the trunk will be conveyed towards exterior by the flexible ventilation hose.

- If you park in closed space with no ventilation possibility, it is advised to close the valve on top of the container.

-In case of leakage and gas odor from the trunk or interior, switch to gasoline and close the top lid of the container. Contact the authorized workshop to fix defect.



WARNING

- Any repair work such as changing or fixing the container's top valve or servicing the regulator should only be carried out by skilled personnel approved by the manufacturing company and within the authorized workshop.
- Also since the container and regulator are traceable components, therefore any repair or change must be duly registered in the associated maintenance identification card.
- Any manipulation and fixing of the gas system by unauthorized individuals, would be considered a breach from the conditions of the guarantee and repair should only be carried out by authorized workshops.

*If equipped

6 TECHNICAL DATA

VEHICL SPECIFICATION PLATE	138
DIMENSION	139
ENGINE TECHNICAL DATA	140
CAPACITIES	141
WEIGHTS	142
ANTI-POLLUTION SYSTEM	143

VEHICLE SPECIFICATION PLATE

1- The specification plate consists of followings:

- Engine number.
- Chassis number.
- Color number.
- Model.

2- Engine number plate

 IRAN KHODRO(PUBLIC STOCK COMPANY) ایران خودرو	
Type Approval	
Chassis	
Pay Load	GVW
Axle 1	Axle 2
System	Year
Type	
Engine	
Cab	
Capt(D + P)	Color

NOTE

Please mention all referred information in specification plate along with other information regarding the owner, date of delivery and Distance made by the vehicle in all your correspondence with IRAN KHODRO or other associations.

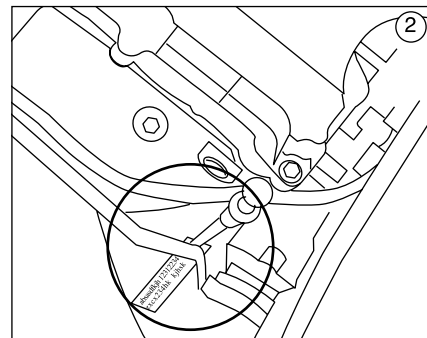
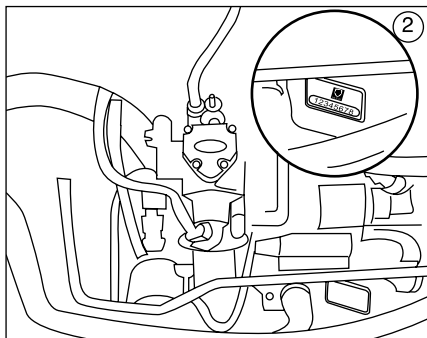
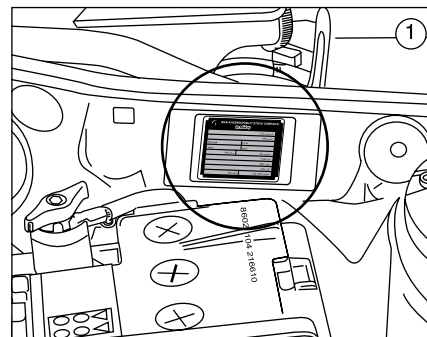
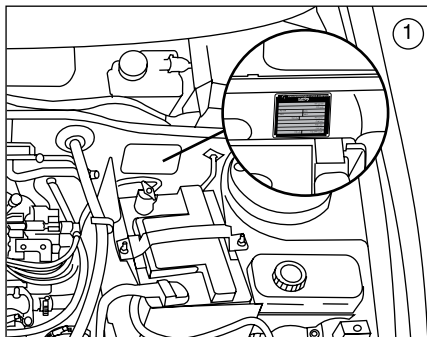

XU7JPL3
& IP 16

TU5JP4L4

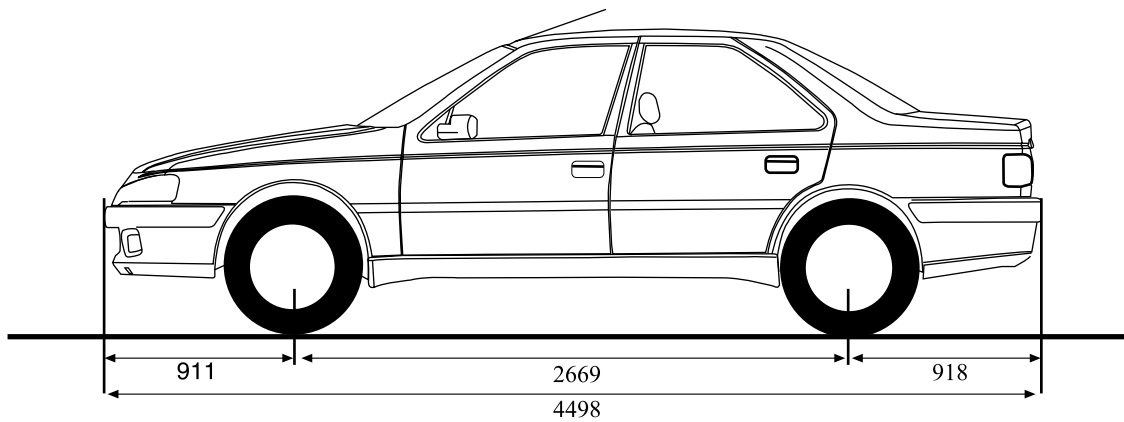
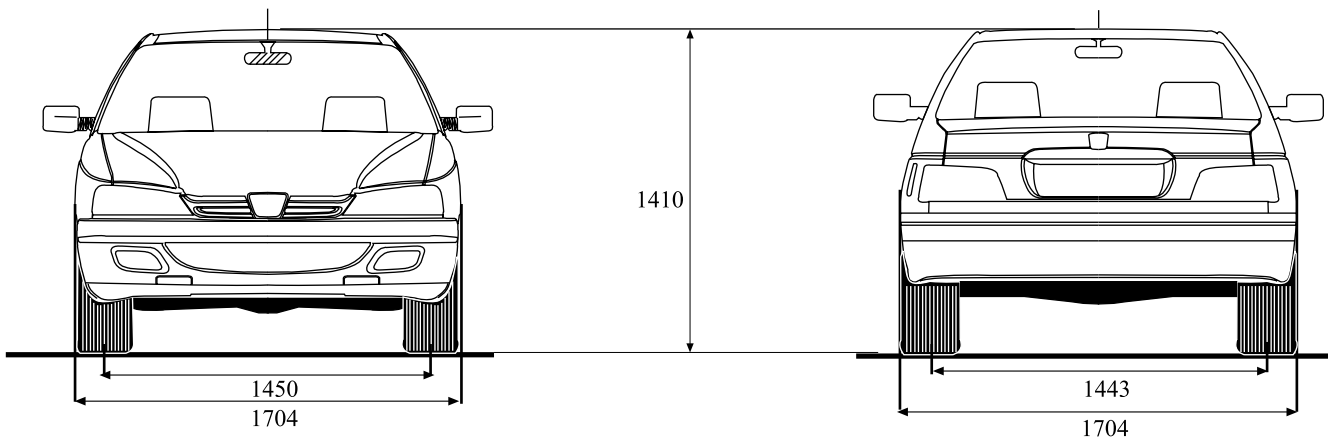

TECHNICAL INFORMATION OF THE ENGINES

Engine Specification	XU7JP4L3	TU5JP4L4
Engine serial number	XU7JP4L3	TU5JP4L4
Volume of cylinder	1761 (cm3)	1587 (cm3)
Diameter & course of the piston	83 X 81.4 (mm)	78.5 X 82 (mm)
Proportional compression	9.3 : 1	10.5 : 1
Minimum fuel Octane	95	95
Maximum engine power	100hp at 6000 (rpm)	108 hp at 5600 (rpm)
Maximum moment	153 NM at 3000 (rpm)	142 NM at 4000 (rpm)
Normal Gear box	BE3, 5 gears + reverse gear	BE4, 5 gears + reverse gear
Automatic Gear box	-----	AL4 + 4 gears
Type of Fuel Injection	Multipoint Fuel Injection System	Multipoint Fuel Injection System
Steering wheel	Shoulder type radius of turning (meter)...5.5	Shoulder type radius of turning (meter)5.5
Brakes	Front: Disc type with 2 shields Back: Bowl type	Front: Disc type with 2 shields Back: Bowl type
Maximum speed of the car	183 (Km/h)	190 (Km/h) Manual gearbox 187 (Km/h) Automatic gearbox

Capacities

Fuel tank's volume	Gas (CNG)	75 Lit.
	Gasoline	66 Lit.
Capacity of rear trunk (Cubic decimeters)		470
Tire	Dimensions:	185 / 65 R 14 or 195 / 60 R15
	Front and back tire air pressure (Inside the city)	29 (psi) 2 (bar)
	Front and back tire air pressure (Outside the city)	30.5 (psi) 2.1 (bar)
Capacity of consumable materials (In liters)	Motor oil without filter	4.40
	Motor oil with filter	4.75
	Normal Gear box oil	1.9
	Cooling system liquid	7.4
	Fuel tank	66
	Front glass cleaner container:	2.7

Advises for fuel consumption

- To decrease the fuel consumption and achieving minimum fuel consumption, note followings:
- 1-Ensure intactness of the engine by periodical inspection and maintenance (on time replacement of the air filter).
 - 2-Use suitable tires (as per user manual) and check the air pressure of the tires.
 - 3-Drive relaxed and avoid unnecessary accelerating and braking.
 - 4-Avoid driving with high speed on road.
 - 5-Do not carry excess loading
 - 6-Switch off vehicle in long period stops.
 - 7-Plan your intercity trip to avoid heavy traffic hours and paths
 - 8-Park the vehicle in suitable places in various seasons (roofed, shadow).
 - 9-Use suitable low gear during driving in downgrade roads, without pressing accelerator.

Type of oil and consumptive materials:**

Parts of the car	Type of consumable materials	Level of Quality
Engine oil. XU7 JPL3 (gasoline) Engine oil TU5	20 W 50* 10 W 40	API - SJ API - SL
Normal Gear box oil	75W80	API GL5
Hydraulic steering wheel oil	(ATF)	DEXRON II-D
Brake oil		DOT 4
Window washing solution	Isopropanol solution	Mixing ratio of 17 to 83 glass washer/water (Summer) Mixing ratio of 44 to 56 glass washer/water (Winter)
Anti freezing liquid	Ethylene Glycole liquid	(Mixing ratio of 46 to 54 anti-freeze and water).

-In case of using 20W50/SL/SJ oil, changing of the oil must be done at 10000 km.

Petrol:

The usable petrol in this vehicle is the super petrol without plumb with octane 95. If any petrol other than above petrol, is used, there will be possibilities of damage and demolition in interior parts of the engine due to effect of hammering and self-consuming.

*It's recommended to use the approved brands and packages, offered by the Isaco.

WEIGHTS

Engine Type conditions	Gasoline (L3) Manual Gearbox	TU5 Manual Gearbox	TU5 Engine with Automatic Gearbox	Bi-fuel engine With 75 lit. gas cylinder
	XU7PL3(BE3)	TU5JP4L4(BE4)	Tu5JP4L4 (AL4)	
Approx.Net Vehicle weight(without passenger & Auxiliary equipments; with a full tank)	1165	1185	1215	1248
Maximum Total weight; with passenger & load	1580	1580	1650	1673
Maximum load on Front Axel	900	900	900	-----
Maximum load on Rear Axel	810	810	810	-----

Pollution Control System

Your vehicle is equipped with pollution control system in regard of vehicle polluting material.

Catalytic Converter:

Catalytic converter or Catalyst is used to react on exhausting pollutant to produce least pollution gases. Lead is of the most important factor in breaking or damaging catalyst. So it is necessary to use lead free gasoline.



CAUTION

- Usage of leaded petrol, damages the vehicle engine.
- Ensure that only standard liquid is mixed with the fuel.

7 INDEX

INDEX

A		Conversion From Gas To Gasoline	93	H	
Adjusting Safety Belts	38	Conversion From Gasoline To Gas	93	Handling Method In Case Of Gas Leakage	135
Adjusting The Steering Wheel	86	D		Heating / Ventilation	16
Air Bag	73	Demisting	63	Hydraulic Steering Wheel	103
Air Pressure Of The Tires	88	Digital Display Screen Guide	85	I	
Anti Pinch System	31	Digital instrument Panel	77	Ignition Switch	13
Anti Theft Security System(Immobilizer)	13	Dimensions	139	Intelligent Speed Control System	20
Anti-Lock braking System(ABS)	68	Disconnection Of Battery	104	Intelligent Windscreen switches	31
B		Driving & Environment	90	Interior Equipment	71
Battery Care & Maintenance	132	E		Introducing CNG Fueling System Placed In Trunk Lid	67
Battery Safety Tips	134	Electric Side Glass Lifter	29	L	
Battery To Battery Connection	131	Engine Compartment	98	Locking & Unlocking of The Doors	24
Brake System	102	Extinguisher	42	Locking / Unlocking Of The Doors	13
C		F		Locking/Unlocking of the Engine Cover Door	28
Capacities	141	Filling Of Glass Cleaner Container	100	M	
Changing The Battery	104	Folding Exterior Mirror (electrical)	41	Maintenance Of The Car	96
Changing The Lamps	115	Front Ash Tray	72	Maintenance Of The Vehicle's natural leather	108
Changing The Wheels	112	Fuel Conversion Key*	92	Manual Brake	87
Charging Battery	131	Fuel Filler Flap	27	Manual Gear Box	87
Checking The Coolant	101	Fuses	117	Mirrors	40,18
Checking The Motor Oil Level	99	G		Mobile Hands free*	48
CNG Parts	66	Glass Cleaner & Windshield Wipers	14		
Child Safety	38				
CNG System Engine Compartment	66				
Controls	10				

O		The Clock	57
Opening the Fuel Filler Flap In Emergency situation	27	The Method Of Renewing The Permit Sticker For Fuelling The Vehicle	94
		Transporting The Vehicle	110
		Tread wear Indicator	114
P		V	
Pollution Control system	143	Vehicle Specification Plate	138
Puncture	114	Vehicle Transport	110
R		W	
Rear Ash Tray	72	Warning Lamps	82
Recommendations For Washing The Vehicle	105	Weights	142
Releasing Of The Lock For Steering Wheel	86	Winter Precaution	91
Reserve Gear Warning System	47		
Routine Services	97		
S			
Safety Of The Road	91		
Safety Of The Vehicle	91		
Saving In Fuel Consumption	89		
Seat Belts Safety Tips	37		
Seats	33		
Starting The Engine On CNG Mode	92		
Starting and Driving	86		
T			
Technical Information of The Engine	140		

Roads await you ...



IRAN KHODRO Company (Public Joint Stock)

Gate No. 1, Iran Khodro Blvd,
KM.14 Karaj Makhsous Rd,
Shahid Lashgari Highway, Tehran, IRAN
Postal Code:1389913657
Tel: (+9821) 48901
Fax: (+9821) 44934000-1
SMS Centre: (+98)30003
E-mail: info@ikco.ir
www.ikco.ir