

e20

OWNER'S MANUAL

Read manual carefully and always keep in vehicle



Clean



Convenient



Connected



Clever



Cost effective

FUTURE OF MOBILITY

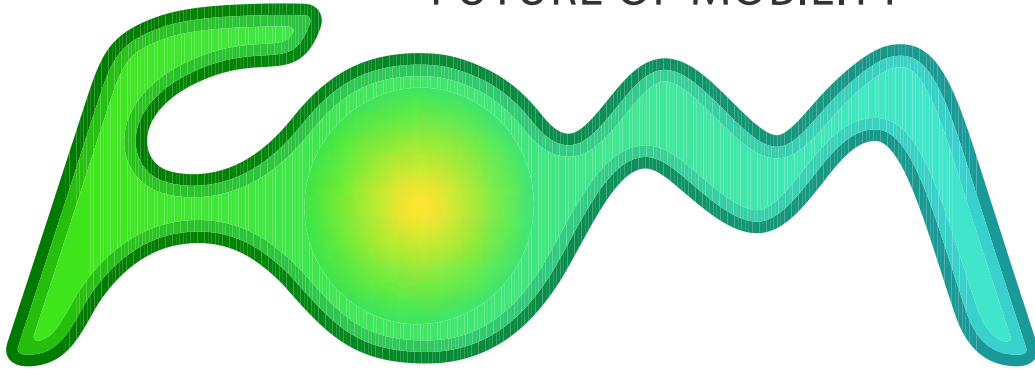



It's electric. Zero emissions.....

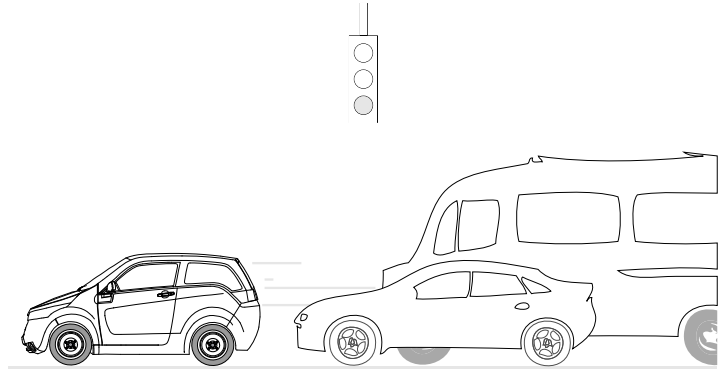

Quickest on road



Dent resistant body panels

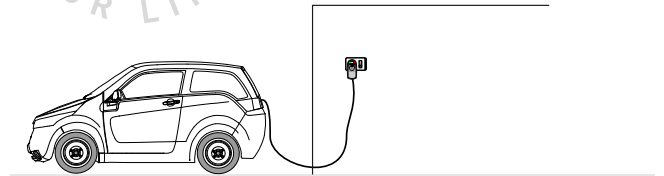

Easy to charge

Congratulations ! You have made a wise decision by choosing to own our automatic electric vehicle!

Welcome to growing family of Mahindra Reva which is a whole new concept in 'Future of Mobility', a step forward towards a pollution free environment that our future generations will thank us for. And with it, will provide you years of hassle free ownership.

Please read this Owner's Manual carefully before operating your vehicle. It has been structured to provide you with all information you need on operation and maintenance of your vehicle while you enjoy the driving pleasure. Please keep it safe in vehicle so that it will be of helpful for required assistance and reference.

Vehicle is provided with a separate warranty manual, Quick reference guide with all necessary details. Please read through carefully on maintenance, Warranty terms and conditions to understand warranty coverage and responsibilities for ensuring warranty protection for your vehicle. Your vehicle Maintenance schedule is also provided in warranty manual. Following the schedule will help to keep your driving hassle free and also preserve your investment.

Everyone here at Mahindra Reva are dedicated to ensure your driving satisfaction. Please email us to CUSTOMERCARE@mahindrareva.com for any clarifications or concerns at anytime.

We wish you joy of commuting without polluting

IMPORTANT

Safety Symbols

Please carefully read, understand & follow safety symbols / instructions in this manual.

Legend of the Symbols

You will see various safety symbols in this manual & are used in below following ways.

Obey all safety messages with words DANGER, WARNING, CAUTION & NOTE having special meanings.



DANGER

This indicates a hazardous situation which, if not avoided, will result in death or serious personal injury.



WARNING

Indicates the presence of a hazard situation that could cause death or serious personal injury.



CAUTION

Indicates a potentially hazardous situation which, if not avoided, may result in minor or moderate injury.

*****: This signifies that an item / feature is optional or may /may not be available with this variant vehicle.

CAUTION

Caution without safety alert indicates a potentially hazardous situation which, if not avoided, may result in property damage.

NOTE

NOTE indicates important information on vehicle's use & maintenance to which particular attention should be paid. The symbol below indicates "NO" , "Do Not do this" or "Never"



All information, illustrations and specifications in this Owner's Manual were in effect at time of printing.

Mahindra Reva Electric Vehicles Pvt Ltd. in course of product development reserves the right to discontinue or change specifications or design at any time without notice, without any liability & obligation whatsoever.

TABLE OF CONTENTS

1.0	Over view.....	6
2.0	EV Overview.....	16
3.0	Charging.....	20
4.0	Safety- Seats, Seat belts and SRS.....	30
5.0	Instrument Cluster and Controls.....	36
6.0	Climate control system.....	48
7.0	My car info and Mobile App.....	54
8.0	Pre drive checks.....	64
9.0	Starting and driving.....	70
10.0	Tyres.....	78
11.0	Do's and Don't's.....	84
12.0	Appearance and care.....	88
13.0	Emergency and user info.....	98
14.0	Technical Specifications.....	102
15.0	Index.....	108

1.1	Car overview	07
1.2	Instrument panel & center console.....	08
1.3	Instrument cluster.....	09
1.4	Cluster display & Indicator lights	10
1.5	Instrument Cluster message display	11
1.6	Hood.....	12
1.7	Rear hatch.....	13
1.8	Charge cable compartment.....	13
1.9	Parking brake.....	14
1.10	Beverage holder.....	14
1.11	Voltage lines & Main components location.....	15

1

OVERVIEW

1.1 CAR OVERVIEW

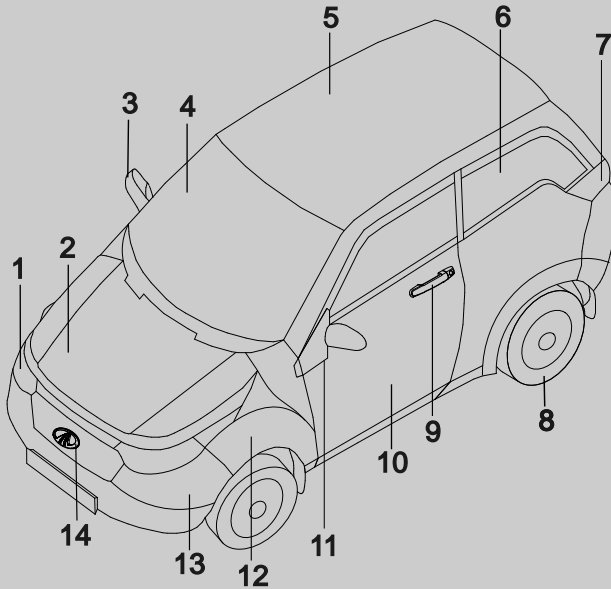

Over View:

1. Head light
2. Hood
3. OVRM
4. Wind shield
5. Roof
6. Fixed glass
7. Tail light
8. Wheel
9. Door handle
10. Monogram
11. Fender
12. Front bumper
13. Front bumper
14. Logo
15. Rear bumper
16. Number plate
17. High mount stop lamp
18. Rear hatch glass

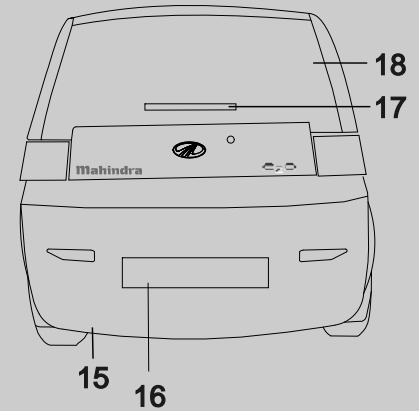

1.2 INSTRUMENT PANEL AND CENTER CONSOLE



1.3 INSTRUMENT CLUSTER

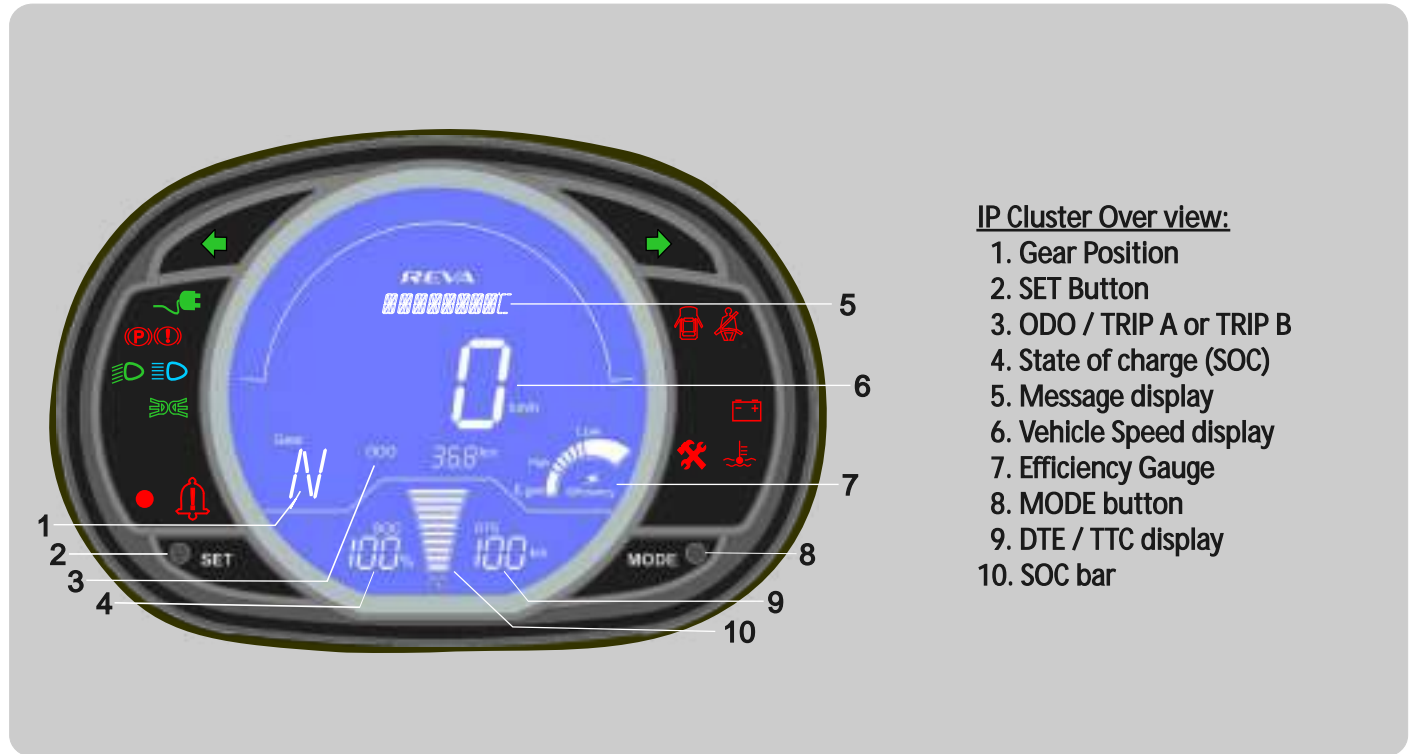

1.4 INSTRUMENT CLUSTER INDICATOR LIGHTS



: Turn signal / Hazard indicator lights



: Charge indicator light



: Parking brake / Low brake fluid light



: Low beam indicator light



: High beam indicator light



: Park position indicator light



: Anti theft indicator lights



: Seat belt (driver side) indicator light



: EV warning indicator light



: Door open indicator light



: Low auxiliary battery indicator light



: Service light
a) Charge or Drive fault - Solid
b) Service Due - Blinking



: Temperature indicator light

1.5 INSTRUMENT CLUSTER MESSAGE DISPLAY

Message display



Cluster message center displays below messages to user with information and guide to monitor and perform actions to get best performance.

In 'Charge'

1. INSERT PLUG FULL : Check and insert charge port handle completely.
2. CHARGING : Car is charging.
3. CHARGE COMPLETE : Charging process is completed.
4. CHARGE TERMINATE : Charging process is stopped by using mobile app.
5. CHARGE FAULT : Charging process will slow / stop due to fault in charge system.

'Idle' / 'Key ON' / 'Drive'

1. UNPLUG CAR : Charge port handle to be removed before turning '**START**' button ON.
2. AUTHENTICATE KEY : Place remote key fob near '**START**' button for authentication.
3. SHIFT GEAR TO 'N' : Push gear lever to '**N**' position after successful authentication, if already not in 'N' position.
4. WELCOME : Car is ready for drive.
5. RESTART : In case of authentication failure, restart again.
6. POWER SAVE MODE : When charge level drops below 10%, car enters 'Limp home' & HVAC will turn OFF.
7. ACTIVATE REVIVE : If charge level drops to 0% SOC, activate '**REVive**' via 'Infotainment' or 'Mobile App'.
8. GO SLOW : Slow down car if temperature light comes on in cluster with this message.
9. STOP CAR : Stop car for a while if temperature light comes on in cluster with this message.
10. CHARGE CAR : If charge level drops to 0% SOC & all REVives are used, plug-in car for charge.
11. SERVICE DUE : If scheduled service is due, this message will appear for 20 sec's at every key on after charge.
12. CHECK BRAKES : Press brake pedal once & message will go OFF.
13. TOPUP BRAKEFLUID : If brake fluid is less than minimum level in reservoir, top-up brake fluid.
14. SAFE MODE : In case of any fault in 'EV drive system', car will continue to drive with low performance.
15. DRIVE FAULT : In case of any fault in 'EV drive system', car will not move from start.
16. ENGAGE HANDBRAKE : If any of door is opened during drive, this message will appear. Always engage parking brake.
17. REVIVE : During 'REVive' activation process, this message will appear on cluster.
18. WARMUP BATTERY : If battery temperature is below sub zero, this message will appear & driving range might be low.
19. CHANGE KEY BATT : If remote key fob battery is low, this message will appear, replace key fob battery.

1.6 HOOD

1.6 HOOD

I. OPENING THE HOOD

- Step 1: Pull hood release lever located below steering wheel.
- Step 2: Locate hood-latch lever under center of hood with your index finger. Pull lever towards left side until it unlocks from latch.
- Step 3: Lift hood and pull support-rod from its mounted clip on fuse box cover and place it in center of hood.

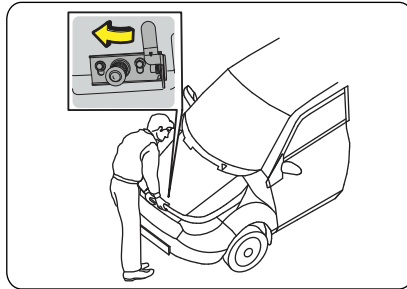
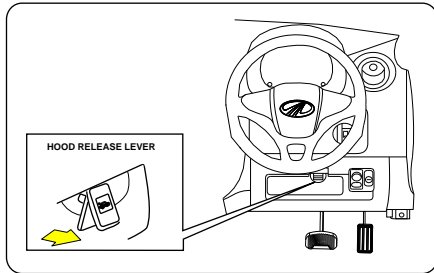

NOTE

Hood light will be on when hood is opened and goes off once it is closed.

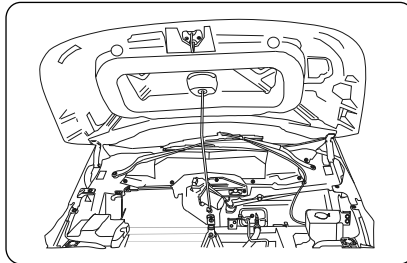

II. CLOSING THE HOOD

- Step 1: Hold support rod & lift Hood slightly upwards, place support rod back to its location.
- Step 2: Lower hood and press it gently downwards till it locks with a click noise.

NOTE

Do not drop hood from height. Ensure that, hood is fully locked before driving.

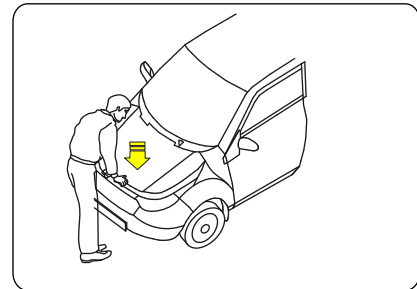

1.7 REAR HATCH / 1.8 CHARGE CABLE COMPARTMENT

1.7 REAR HATCH

To release rear hatch, press hatch release button on HVAC control unit. When vehicle is in locked condition, use remote key fob to release hatch.

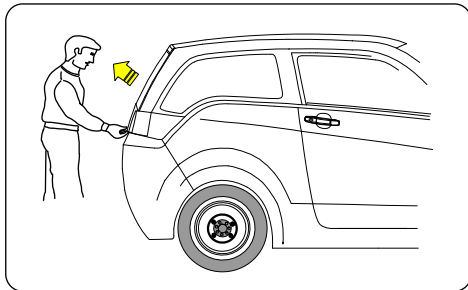
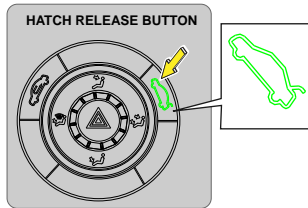

CLOSING REAR HATCH

Close rear hatch to 3/4 and then gently drop the hatch down till it locks into position with a click noise.

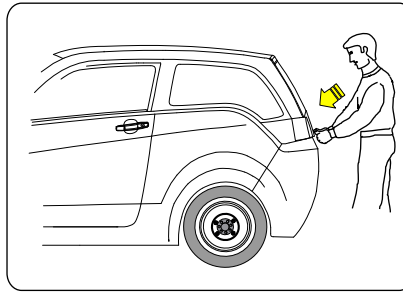

⚠ CAUTION

Do not drop the hatch from open position. Be careful in hatch open / raised condition as you may get hurt.

1.8 CHARGE CABLE COMPARTMENT

Compartment in rear is provided to store your charging cable.

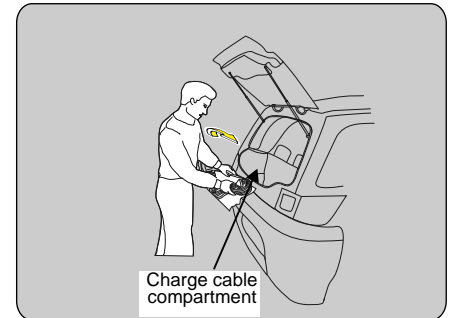

1.9 PARKING BRAKE / 1.10 BEVERAGE HOLDER

1.9 PARKING BRAKE

To Engage-

1. Pull brake lever (1) upwards.

To Disengage-

1. Press & hold button (2) on lever.
2. Release handle (3) with a slight downward push.
3. Ensure handle is fully released before driving car.

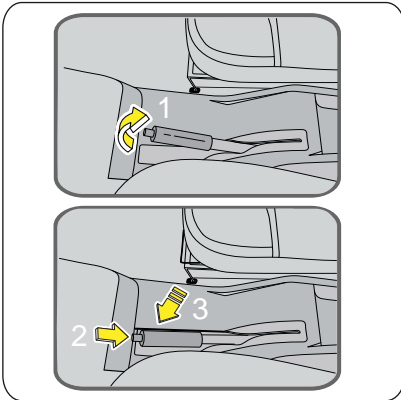

NOTE

- a) In event of parking brake not released during drive, beep sound will be heard indicating user to release parking brake.
- b) In the event of parking brake not engaged & door opened, beep sound will be heard indicating user to pull parking brake before exiting from car.

CAUTION

- Do not leave children or adults requiring special attention in car when parked in gradients with hand brakes on, as car does not have gear lock system and unknowing release of parking brake can result in rolling of car and cause accident resulting in injury / death.
- Never drive your car with parking brake engaged. Doing so, your drive range will reduce.

1.10 Beverage Holder

A beverage-holder is provided for rear seat passenger to place a cup or a bottle.

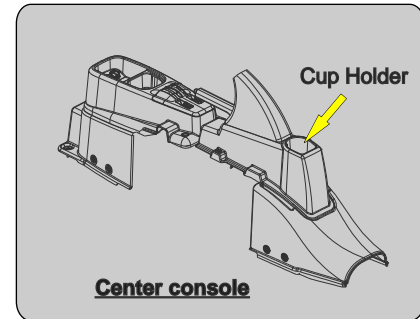

CAUTION

Use 'Beverage holder' carefully as spilled liquid if very hot can scald you or other passenger. Spilled liquids can also damage upholstery, carpeting and electrical components.

1.11 VOLTAGE LINES & MAIN COMPONENTS LOCATION

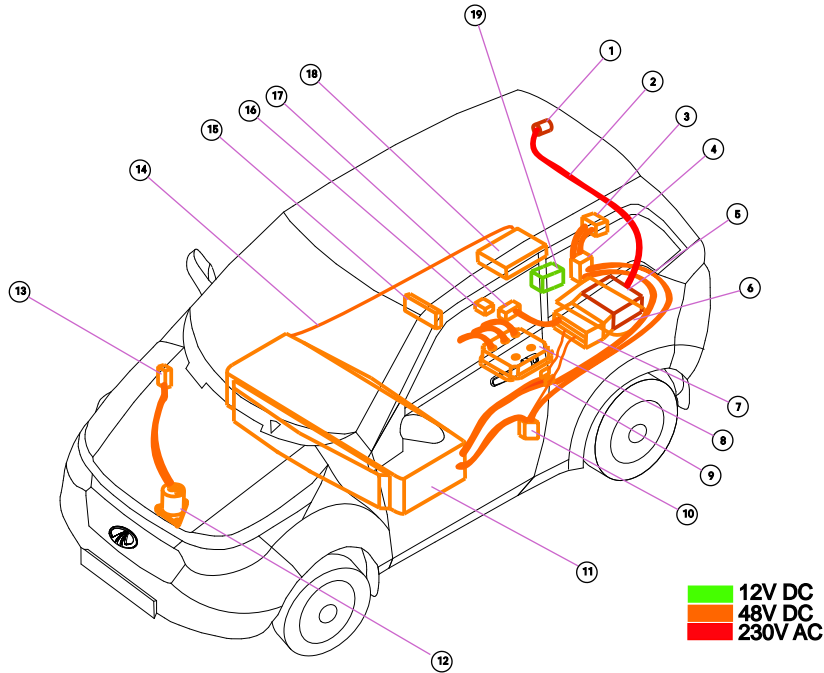

Over view:

1. Charge port
2. Charge port harness
3. Fast charge port
4. Fast charge port contactor
5. Charger input - 220V AC
6. Charger
7. Charger - 48V output
8. Drive Motor controller
9. Shunt
10. Contactor
11. Battery pack
12. Air conditioner motor
13. Air conditioner controller
14. Pack sense harness
15. Data port
16. Telematic unit
17. Wake up relay contactor
18. IEMS
19. Auxilliary 12V battery

2.1	Electric vehicle system.....	17
2.2	Warning and Cautions.....	18
2.3	Notes.....	19

2

EV OVERVIEW

2.1 ELECTRIC VEHICLE SYSTEM

2.1 ELECTRIC VEHICLE SYSTEM

Electric vehicle operates differently compared to an internal combustion engine vehicles as it is powered by battery power pack. Car battery must be charged with electricity before driving it. As car is driven, stored energy in battery pack gradually decreases and if discharged completely to 0% then will not drive until battery pack is recharged. Charging time varies depending on state of charge in car and ambient conditions. Normal charge time is 5 hours.

An auxiliary 12V battery in car, enables to wake up car in case 'Vacation Mode' is activated in car at idle condition.

Battery pack powers drive motor and car is equipped with regenerative electric braking and vacuum assisted hydraulic brakes.

Electric car is an eco friendly vehicle that does not release any noxious emissions like carbon monoxide, carbon dioxide & nitrogen oxide.

WARNING

The vehicle has sealed Li-ion battery pack. Improper disposal of battery could lead to risk of severe burns and electrical shock that may result in serious injury or death and also may cause damage to environment.

CAUTION

For preventing damage to the Li-ion battery pack:

1. Do not expose to very high temperatures for longer duration.
2. Do not use car battery for any other purpose, consult your dealer or manufacturer for help.

Always check available energy for your required travel distance by checking 'state of charge' and also 'distance to empty'. When ever charge level goes below 15%, the SOC bar starts blinking giving an indication to user to drive carefully to reach destination. If charge level drops below 10%, car will drive in 'POWER SAVE MODE' reducing car performance and automatically turns off airconditioning.

Vehicle has 'REvive' feature that can be enabled if energy level drops below 10% 'State of Charge'.

Battery pack will get discharged when it is parked idle for long time. Hence activate 'Vacation Mode' via mobile application to optimize charge level and avoid deep discharge.

2.2 WARNING & CAUTION

⚠ WARNING

Vehicle uses a 48 volts battery system. Some of systems could be hot before & after their usage. Hence pay attention and follow warning labels located at places in vehicle.

Never try to access, remove parts / cables / connectors which can cause shock or severe burns or result in serious injury. 48 voltage cables are colour coded in Orange & systems are not user serviceable. For any maintenance, contact your authorised service center.

In event of accident:

1. If vehicle is in drivable condition, move vehicle off the road, park & switch off drive system.
2. Check for any exposed 48 volts cables / parts. To do so check picture indicating voltage layout of the system. Never touch any exposed 48 volts wiring & avoid any possible electric shock.

3. In case of any high impact on to battery compartment floor area, do stop at safe location & check floor area for leaks or damages that can cause fire. In case of fire in EV (electric vehicle), leave vehicle immediately. Only use ABC, BC or C type of fire extinguishers recommended for electrical fire hazards.



For any reason to tow vehicle, do it with recovery vehicle support. In event of not doing so, drive motor may generate electricity, can cause damage to EV components and may result in fire.

If vehicle cannot be assessed for extent of damage, do not touch vehicle and contact nearest authorised service center or customer care executive for support. To any requirements of body repair due to accidents, vehicle should be delivered to authorised service center to evaluate damage & take necessary precautions. Damaged Li-ion battery modules could pose safety risks to untrained technicians & repair person.

⚠ CAUTION

Special Attention:

- ✍ Make sure to turn off drive system before leaving vehicle.
- ✍ Engage parking brake prior to getting out of the vehicle.
- ✍ Do not allow untrained person to access EV system and apprise immediate responders in any events that this is an electric vehicle.

NOTES:

- ✍ Vehicle will not run with completely discharged battery. At low SOC avoid repeated acceleration resulting in more energy consumption that can be avoided by gradual acceleration and maintaining steady speed.
- ✍ Driving in down gradient, when accelerator pedal is released, regenerative brakes will provide some energy to recharge battery pack and simultaneously assists in deceleration of vehicle assisting in vehicle control.
- ✍ Brake should be applied to slow down or stop vehicle in drive.
- ✍ You may hear some sound and feel vibration in drive that are normal.
 - a) Drive motor makes small sound during its operation, also will be higher in deceleration of vehicle.
 - b) Brake vacuum pump makes sound during braking operation.
 - c) Contactor makes sound when vehicle is switched on and authentication.
 - d) In AC cooling, motor and condenser fan comes on during operation.

NOTES

- ✍ In event of battery temperature is below 0°C or less, battery pack will not accept charge, hence park your car at warm climatic condition.
- ✍ In event of battery temperature is below -5°C, car will not drive, hence park at warm location.
- ✍ Performance of battery will decrease with time and usage and does not indicate any defect in battery pack.
- ✍ Battery pack has limited life and when its charge holding capacity reaches below specific level, it may require an inspection from service persons and may need battery pack replacement.
- ✍ It is recommended and mandatory that during process of battery or vehicle / components disposal, owner should contact authorised dealer for guidance and information on recycling or proper disposal without causing any environmental pollution.

- ✍ During drive as the charge level drops below 20%, car will drive in 'E' (ECONOMY) mode limiting drive power. Further if charge level drops below 10%, car will drive in 'L' (LIMP HOME) mode with POWER SAVE MODE message on cluster. If heater or AC is ON, will get turned off, blower continues to work.
- ✍ Driving in 'B' mode with high acceleration will result in more power consumption reducing your drive range.

3.1	Vehicle Charging and warning.....	21
3.2	Types of Charging.....	22
3.3	Normal Charging.....	22
3.4	Charge duration.....	24
3.5	Ideal time.....	24
3.6	Intelligent Charging system.....	24
3.7	Fast Charge.....	25
3.8	Trickle Charge.....	26
3.9	Charge precautions.....	26
3.10	Charging high voltage lines.....	27
3.11	Charging Troubleshooting.....	28
3.12	Charging point requirements.....	29

3

CHARGING

3.1 VEHICLE CHARGING / WARNING

3.1 Vehicle Charging:

Car requires charging of battery power pack once energy stored in it gets depleted.

There are two methods of charging battery power pack.

1. Normal charging
2. Fast charging (if equipped)

Time to charge battery pack varies based on state of charge, ambient & battery temperature. Hence charging time specified is an estimate and may vary.

WARNING

- ✎ In case if you use any medical electric devices like implantable cardiac pace maker or cardio vascular defibrillator, do check electric medical device supplier / manufacturer on concerns of effects that EV charging or discharging system on implanted such devices prior to their operation.
- ✎ It is also advised not to stay in vehicle or access vehicle during charging as it may effect function of electric medical devices and could result in personal injury or death.
- ✎ Also make sure that there is no foreign particles or water traces in charge plug or port as any of these can result in electric short circuit or shock causing serious injury or death. Hence do not touch metal contacts on cable or plug.
- ✎ Do not drag or keep charge cable close to any heat source.

- ✎ Ensure that power socket is switched off before accessing charge cable.
- ✎ Do not handle charge cable or port with wet hands as it may cause electric shock resulting to injury or death.
- ✎ Do not pull or twist cable and always remove by holding charge port handle after switching off plug point.
- ✎ Do not modify port or cable as it may cause fire hazard.
- ✎ In case if you observe an unusual odor or smoke coming from vehicle, do immediately stop charging process.
- ✎ Always make sure charge cable is disconnected from on board charge port prior to drive.
- ✎ Charging may affect operation of worn or implanted electric medical devices and could result in serious injury or death.

3.2 TYPES OF CHARGING / 3.3 NORMAL CHARGING

3.2 TYPES OF CHARGING

Car can be charged using house charging unit installed at home or at office or with charge cable provided with car.

Normal charging:

Always charge your car using charge cable supplied with vehicle. It normally takes approximately 5 hours to full charge from completely discharged battery.

Fast charging (if equipped)*:

A separate fast charge port is provided in rear bumper to charge battery power pack quickly in 60 minutes time. Fast charging cannot be done at home, this charging can be availed at places where 'Fast charge' stations are available exclusively for Mahindra Reva vehicles. It is recommended to use Fast charging only in emergency needs and not always.

Refer 'Fast charging' in section 3.7

3.3 NORMAL CHARGING:

Charging your car is safe and simple in Just 4 steps:

Step 1: Ensure parking brake is applied & STOP button is in OFF position.

Step 2: Open rear hatch and take charge cable from vehicle, located behind rear seat.

Step 3: Plug in one side of charge cable to vehicle charge port, ensure cable is pushed completely and close rear hatch.

Step 4: Plug in other end into charge point on wall socket and turn on power supply switch.

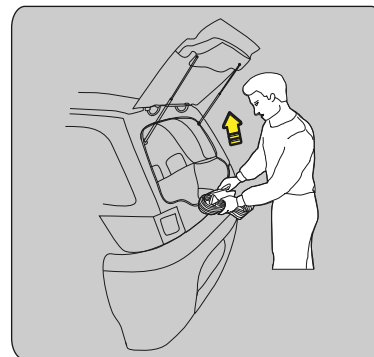
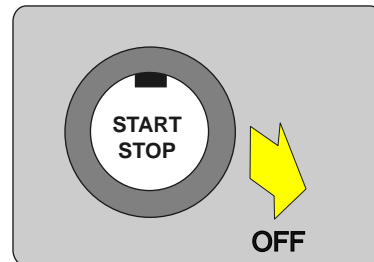
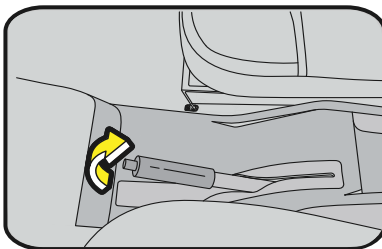

Vehicle is now on charge. Charge Light (green) indicator will flash & turns solid once charging is completed.

3.3 NORMAL CHARGING

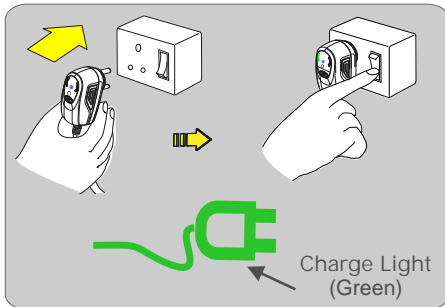
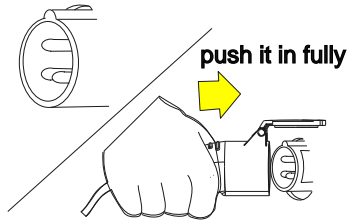

⚠ CAUTION

Always ensure that rear hatch is closed during charging process. If not water can enter from rear and damage electronics during raining.

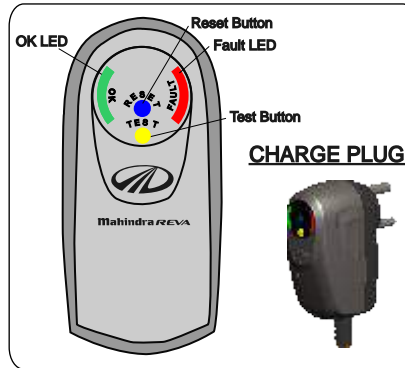

OK LED :

Green LED light indicates normal charging and healthy earth in charging circuit.

Fault LED :

Red LED light indicates fault in charging circuit for under or over voltages and residual current trip fault.

Reset Button :

In event of earth leakage or any other faults it will trip. Press to reset after rectifying the issue.

Test Button:

Press to evaluate healthy condition of electric power supply once in a while if cable is being used sparingly that also shows cable is working OK or faulty.

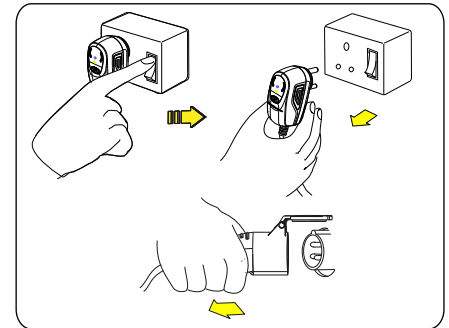

Once charging is completed, first switch off power supply, then remove charging cable from plug point and on-board charge port.

Roll and keep charge cable in its compartment behind rear seat.

3.4 CHARGE DURATION / 3.5 IDLE TIME / 3.6 INTELLIGENT CHARGING SYSTEM

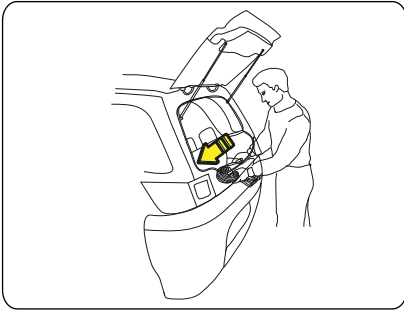

3.4 CHARGE DURATION

Time taken for charging can vary up to 5 hours from complete discharged condition.

Charging duration may vary:

- 1) If battery power pack temperature has reached its maximum limit, charging will slowdown and will take longer time to charge.
- 2) If battery power pack temperature reaches minimum limit less than 10°C, charging will slowdown and will take longer time to charge.

HOME CHARGING UNIT:

Always use installed 'HOME CHARGING UNIT' for charging your car at home or office. Use charge cable provided with car for charging at other charge points having proper earth.



Home charging unit

3.5 IDEAL TIME TO CHARGE

Vehicle can be charged anytime with availability of charging facility, however charging can be done at suitable time that has following advantages:

1. Normally most of requirements for city mobility are during day, hence charging at night will not interfere in daily travel plans.
2. At night, ambient temperature is less, ideal for battery charging.

3.6 INTELLIGENT CHARGING SYSTEM

This vehicle has unique Intelligent Energy Management System [IEMS] that controls energy flow from mains to battery power Pack through on board charger. It will optimize energy consumption to charge battery pack completely.

Further more if there is voltage fluctuation or an interruption in main power supply, system remembers point at which charging was interrupted and resumes charging from there onwards.

3.7 FAST CHARGING

3.7 FAST CHARGING*

Car is fitted with an onboard fast charging port which uses high DC (current) supply for charging. This requires DC fast charging station installed exclusively for Mahindra Reva vehicles at various locations in city. (Contact service center and Customer care for information).

Steps for fast charging:

1. Check for fast charging station availability in the region.
2. Park vehicle near to fast charging station and ensure STOP button is turned OFF.
3. Take fast charge cable from station, insert connector with slight push into vehicle fast charge port located next to rear license plate.
4. Preset charging time and press start button on fast charger.
5. Car will charge as per charge settings selected at the time of charging.

6. Once charging is completed press stop button on fast charger and remove charge cable connector from car and fit back to fast charge unit.

Charge Duration:

- ✍ Normally charging by this mode is approximately 60 minutes from fully discharged condition.
- ✍ With a quick charge for 15 minutes will charge 25% SOC.

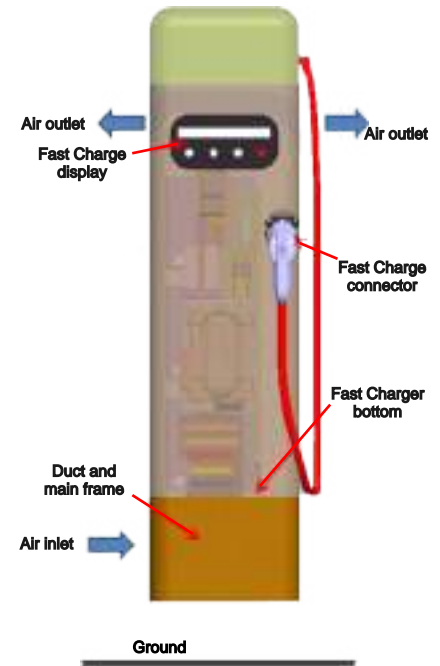
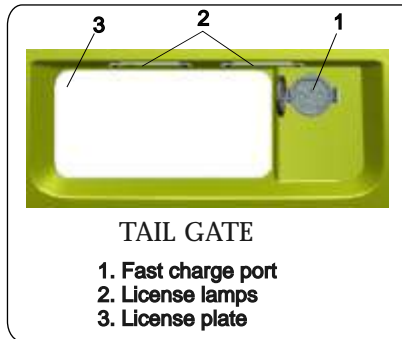

FAST CHARGING STATION

3.8 TRICKLE CHARGING / 3.9 CHARGING PRECAUTIONS

3.8 TRICKLE CHARGING

1. Trickle charge process enables vehicle battery power pack to be topped up in every 24 hours to compensate loss due to idle discharge in vehicle.
2. In the event of vehicle is not used for long time, eg. more than 1 week, plug in vehicle for charge and enable VACATION MODE using mobile app. This will ensure that batteries will be stored in safe charge storage limits enhancing battery life.

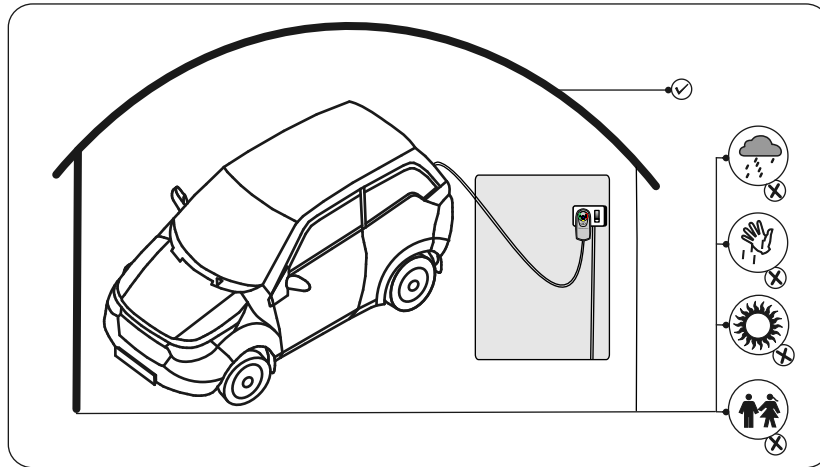

3.9 CHARGING PRECAUTIONS

1. Always use charge cable provided in car for charging.
2. Do not charge your vehicle, if Power Socket and / or charge port are exposed to rain or water.
3. Do not plug-in with wet hands.
4. It is recommended not to charge your car in direct sunlight.
5. Make sure that children are kept away from both on-board and external charge ports, while charging.
6. Car should be disconnected from power source before getting any services being carried out.

3.10 CHARGING HIGH VOLTAGE LINES

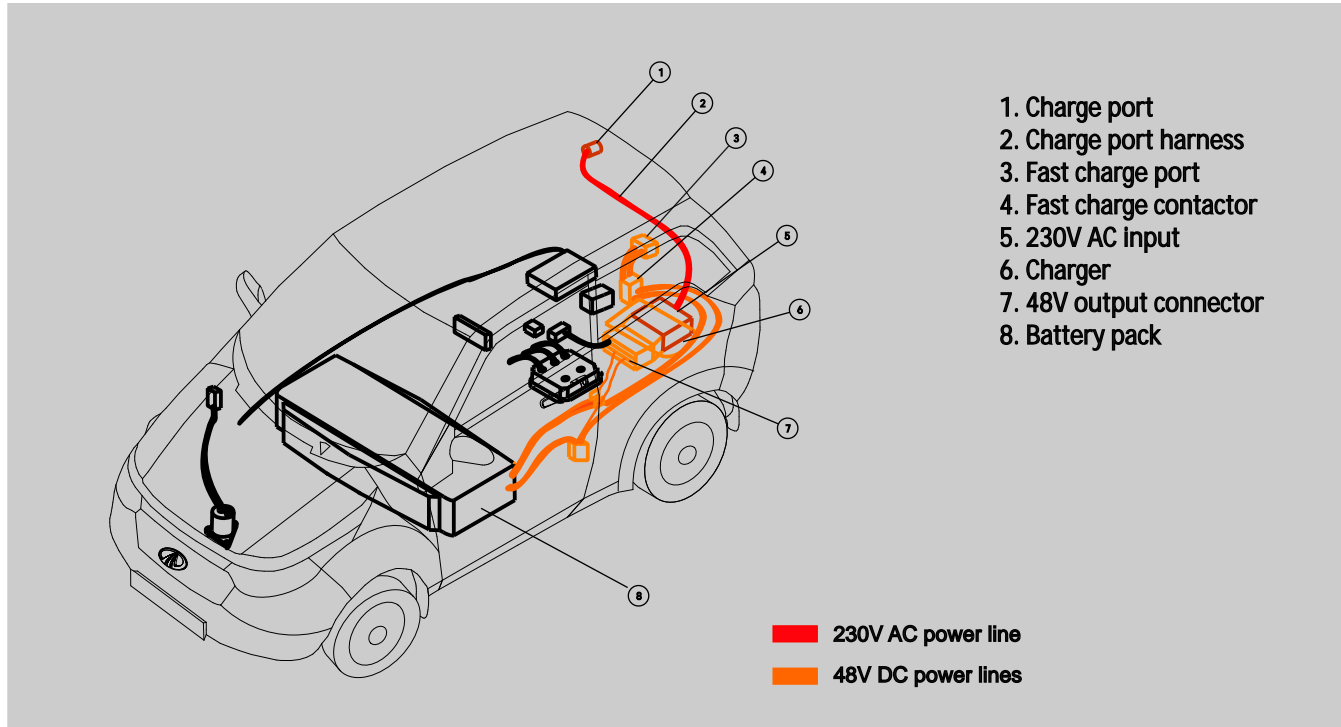

3.11 CHARGING TROUBLESHOOTING

	PROBLEM	POSSIBLE CAUSE	REMEDY
I.	Charge Light does not come on when car is put on charge and 'INSERT PLUG FULL' message.	<ul style="list-style-type: none"> ▣ There may not be power supply at External Power Source. ▣ Charging Cable may not be properly connected to Power Source or not inserted properly to Charge Port. 	<ul style="list-style-type: none"> ▣ Power Supply needs to be restored / ensured. ▣ Re-insert charging cable to Power Source and / or push handle fully on to Charge base Plate and observe on cluster message 'Insert plug full' goes off.
II.	Temperature Light is on while charging.	<ul style="list-style-type: none"> ▣ Charging time of car may increase due to high battery / charger or ambient temperature. 	<ul style="list-style-type: none"> ▣ Check for cooling fan noise and charge in shade/cooler temperature or during night when ambient temperature is low.
iii.	Car does not charge with 'CHARGE FAULT' message on cluster.	<ul style="list-style-type: none"> ▣ May be problem in charging system. 	<ul style="list-style-type: none"> ▣ Contact dealer for assistance.
	<u>RCD:</u>		
I.	OK LED not ON	<ul style="list-style-type: none"> ▣ Power supply interrupted, may not be switched on or earthing is not OK. 	<ul style="list-style-type: none"> ▣ Restore power supply / switch on power or get earth of point rectified.
II.	Fault LED ON	<ul style="list-style-type: none"> ▣ Power supply voltage is low or high. ▣ High leakage current at charge plug. 	<ul style="list-style-type: none"> ▣ Get supply voltage corrected. ▣ Get plug point wiring rectified. (Reset RCD and check)
III.	RESET Button tripped	<ul style="list-style-type: none"> ▣ Earth leakage current is high 	<ul style="list-style-type: none"> ▣ Get earth circuit rectified.

3.12 CHARGING POINT REQUIREMENTS

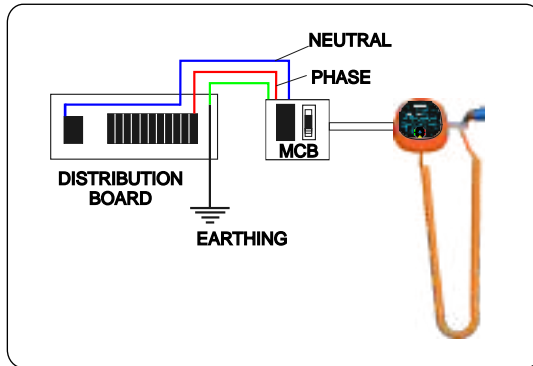
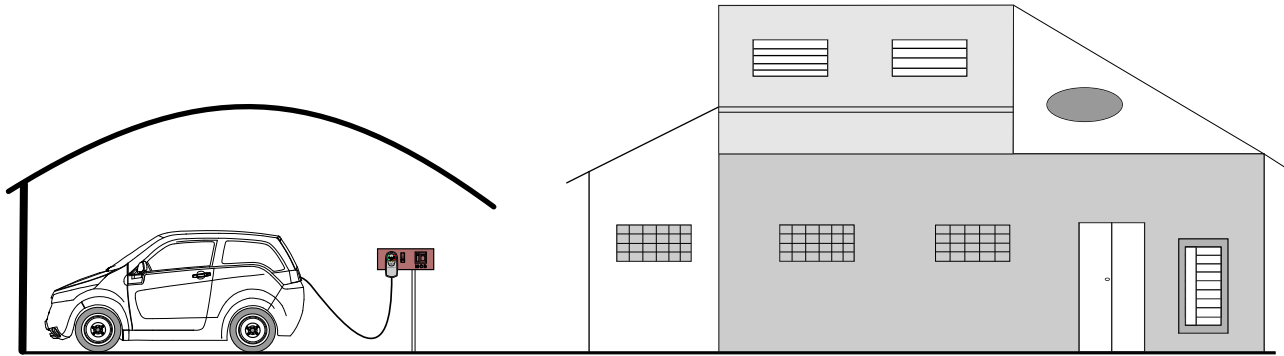

NOTE

Charge Point Specification:

Power requirement: 3KW, Single phase

Plug Socket: 15Amps SP 220V

Wire thickness: 4sq mm for 25 meters, 6sq mm up to 100 meters length

SAFETY: The power source should have MCB & proper earthing.

4.1	Warning.....	31
4.2	Seat adjustment.....	32
4.3	Rear seat access.....	32
4.4	Seat belts.....	33
4.5	Head rest (SRS).....	34
4.6	Notes.....	35

4

SAFETY - Seats, Seat belts and SRS

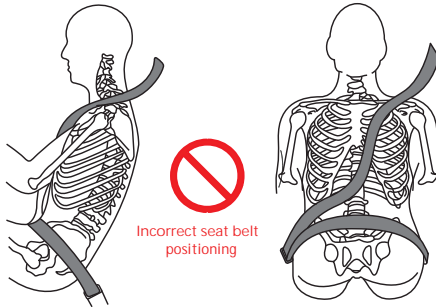
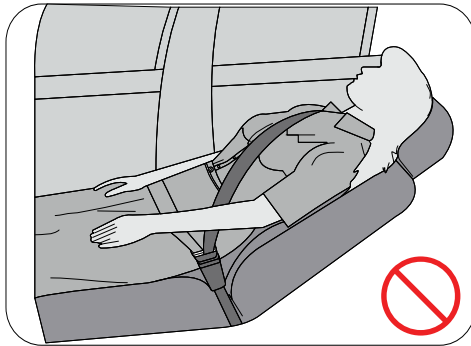

WARNING

- ✎ Never ride in a moving vehicle with seat reclined. This can lead to getting thrown out and cause injury to neck or other serious internal injuries in event of any accident or sudden braking.
- ✎ During vehicle in motion, seat should be upright. Ensure that always sit well back in seat with both feet down and adjust seat belts properly.
- ✎ Ensure that seat is securely locked after adjustments by gently rocking seat forward or backward.
- ✎ Never leave children unattended in vehicle, they may unknowingly activate controls or switches that could result in serious accidents.
- ✎ Never recline seat back rest more than needed which could reduce effectiveness, can cause injuries in event of accidents or sudden braking.

Head Rest:

Head rests are adjustable and are supplement to other vehicle safety systems. They provide additional protection in certain front & rear collisions. Check adjustment every time and adjust if required when ever seats are used by someone else. Failure to do so by not following instructions will reduce effectiveness of head rest and could increase risk of injury or death in event of accident.

Never attach anything to stalk of adjustable head rest.

4.2 SEAT ADJUSTMENTS / 4.3 REAR SEAT ACCESS

4.2 SEAT ADJUSTMENTS

I. FRONT SEAT ADJUSTMENTS

For adjusting front seating position that is most comfortable, a lever is provided under front side of the seats. To adjust pull up, hold lever and slide forward or backward for your requirement and release lever for locking.

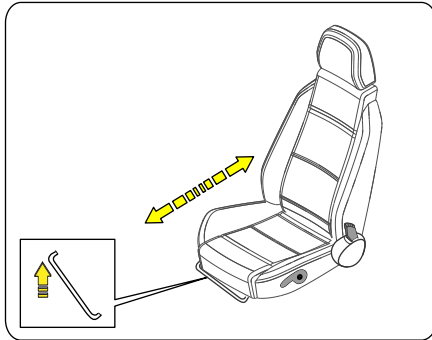

II. RECLINING THE SEAT REST

To adjust rear back rest to most comfortable position, a recliner lever is provided at side of the front seats. Pull recliner lever upwards and release it for locking once aligned to desired position. Recliner lever is located on right hand side for driver's seat and left-hand side of passenger's seat.

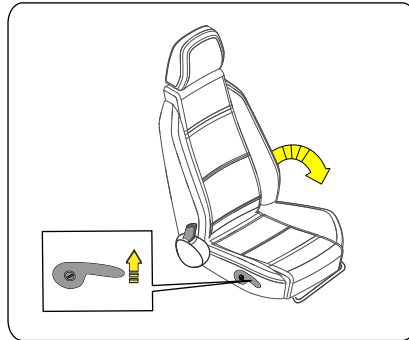

4.3 REAR SEAT ACCESS

Rear seats can be accessed from both sides of vehicle. To do so:

- Step 1: Pull up rear recliner lever of front seat provided at sides.
- Step 2: Front seat will slide & seat rest will recline forward for easy entry & exit.
- Step 3: Make sure front seat is returned back to normal position prior to your drive.

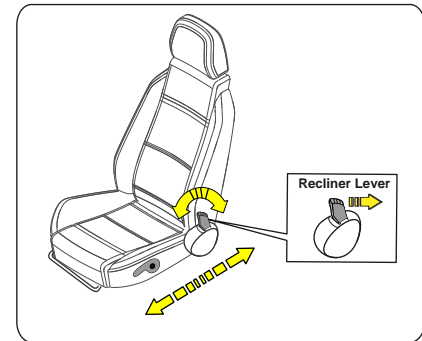

4.4 SEAT BELTS

REAR SEAT

A : Tool kit & warning triangle are placed in rear seat rest pouches.

B: Press release lock and pull head rest for adjustment.

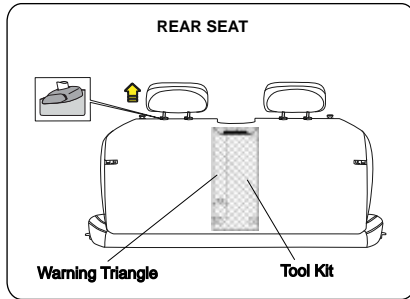

⚠ CAUTION

Position of seat backrest should always be in an upright position when driving, or seat belt effectiveness may be reduced.

Always adjust seat before driving. Never attempt to adjust seats or belts while driving.

4.4 SEATBELTS

Both front and rear seats are fitted with 3-point type safety belts with retractor for maximum protection from any inadvertent event.

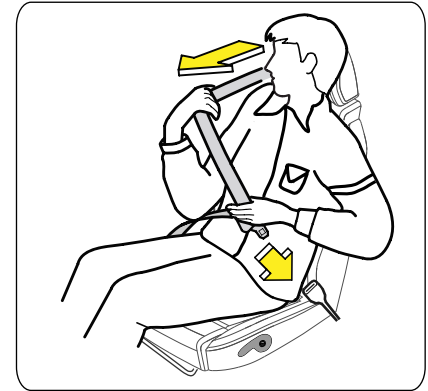
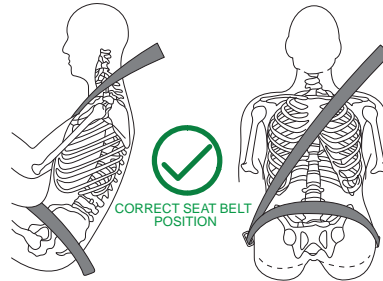

Front seats are of ELR (Emergency locking retractor) type. In emergency situations or crash, retractor instantly locks securing the occupant and prevents injury.

To engage seat belt:

- ✎ Insert latch plate into the buckle till click sound is heard & latch engaged. Make sure belt is securely latched and check that belt is not twisted.

4.4 SEAT BELTS / 4.5 HEAD REST (SRS)

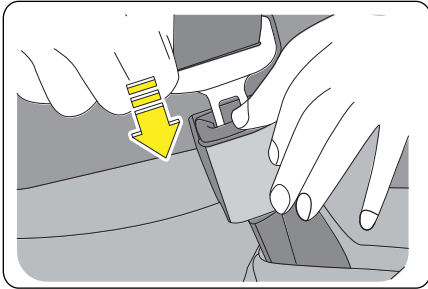

To unfasten belt, press release button on latch buckle.

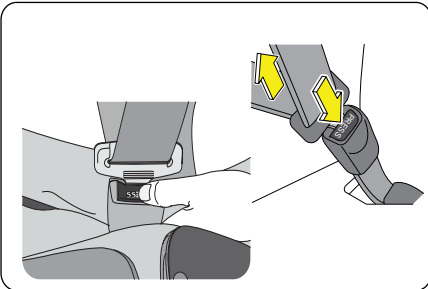

REAR SEAT BELTS:

For rear seat, seat belts are ALR (Automatic locking retractor) type that works both as ELR and ALR but has a switching over point indicated by a click as you pull seat belt. Sit upright and adjust belt length and latch buckle.

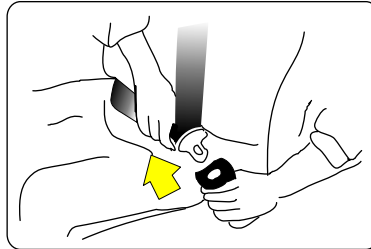

ISO fix child seat mount:

Car seats restraint system is equipped with child seat mounts. This helps in seating young children needing attention securely. Using these mounts that enables child safety seats to be quickly and safely secured while being driven.

CAUTION

Make sure all seat-belts are properly fastened before driving for safety.



4.5 HEAD REST (SRS)

SUPPLEMENT RESTRAINT SYSTEM

Adjustable head rests is a supplement restraint system with other safety system in vehicle. Head rest can be adjusted for height with help of button located on it. Press & hold button to raise, then pull headrest upward to a level most comfortable and to lower, push it down.

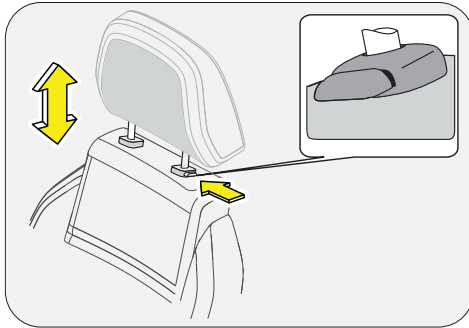

⚠ CAUTION

It is dangerous to drive without headrest.



NOTE

- ✍ Make sure you remove hard or breakable objects lying in your pockets, dress, if any, before wearing seatbelts.
 - ✍ Seatbelt is equipped to be used by one person only. Never use seatbelts for more than one occupant.
 - ✍ Ensure that seatbelts straps are not twisted while in use.
 - ✍ Pregnant women are recommended to wear seat belts for protection. Please consult your doctor for any specific recommendations.
 - ✍ Never attach seatbelt over a child or infant in occupant's lap.
- Pregnant Women**

Pregnant woman should wear lap belt snugly and as low as possible over hips. Shoulder belt should be worn across shoulder but never across abdomen area. When worn properly, it will protect both mother and fetus in any event of accident or emergency stop.

Child restraint system:

Children and infants must never be transported without a proper restraint system. This system can be purchased from the market. Ensure that system purchased meets all applicable standards and safety measures. Use as per instruction of manufacturer while seating the child in front seat.

Injured Persons:

MREVPL advises that injured persons use seat belts depending on nature of injury. Check with doctor for specific recommendations.

Cleaning the seatbelts:

Never use any harsh detergents to clean seatbelts as this may render them ineffective. Inspect seatbelts regularly for excessive wear and tear. If any damages/frays etc are found, replace seatbelt immediately. Do not attempt to tamper seatbelts as this may affect the performance of seatbelts.

5.1	Instrument Cluster.....	37
5.2	Head lights.....	38
5.3	Turn signal and Indicators.....	39
5.4	Indicator Lights	40
5.5	Speedo and ODO meter.....	41
5.6	MODE and SET button.....	42
5.7	Efficiency gauge.....	42
5.8	SOC and Gauge bar.....	42
5.9	DTE and TTC indicator.....	43
5.10	Windscreen wiper and nozzle.....	43
5.11	Gear lever and Drive modes.....	44
5.12	Glove box and Bottle holder.....	45
5.13	Accessories.....	46
5.14	Infotainment system.	47

5

INSTRUMENT CLUSTER AND CONTROLS

5.1 INSTRUMENT CLUSTER



5.2 HEAD LIGHTS

5.2 HEADLIGHTS

This lever operating headlights has three positions. They are:

1. OFF - In this position, all lights are off.
2. Middle Position - Front parking lights, tail Park lights, licence plate lights and dashboard backlighting is lit.
3. Third Position - Headlight HI or LOW beam comes on with other middle position lights when lever is turned with HI or LOW position.

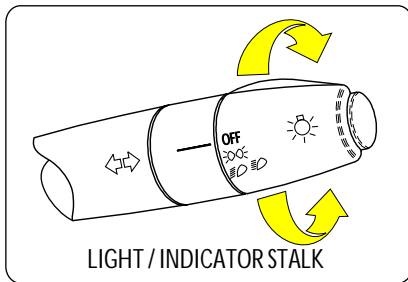

I. PARKING LIGHT

Rotate knob on lighting stalk to first position to turn on parking light.

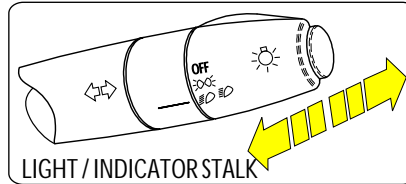

II. LOW BEAM / HIGH BEAM

- ✎ Rotate knob to next position to turn on head lights.
- ✎ For high beam, pull lever upwards until you hear a click, then let go.
- ✎ In off condition, to flash high beam, pull lever slightly towards you and release it quickly.
- ✎ For 'Low beam' push lever downwards to hear a click noise.



III. LOW BEAM

Indicates head light low beam ON when turned on

- a) Low beam with door close-indication ON
- b) Low beam with door open- indication ON with beep.

IV. HIGH BEAM

indicates head light HI beam on when turned on

- a) High beam with door closed - indication ON
- b) High beam with door open- indication ON with beep.

V. FOLLOW ME HOME HEAD LIGHT

To activate, turn on and off head light switch for 2 times within 1 second, lights will be on for 30 seconds after doors are locked, assisting you in parking exit.

5.3 TURN SIGNALS & INDICATOR

5.3 TURN SIGNALS

Turn signal lights blink when you select stalk for a lane change or a turn.

1. Push side indicator stalk forward for left turn and backward for right turn.
2. During high speed lane change push stalk upwards or downwards within a second for automatic 3 blinks.

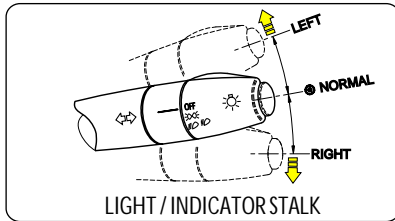

TURN INDICATOR

Indicates left or right blinking with position of indicator stalk. Both blinkers will flash together when hazard button is selected.

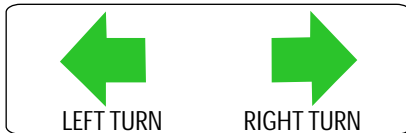

In case if it is blinking faster than normal, then one of indicator bulb is fused and bulb needs replacement.

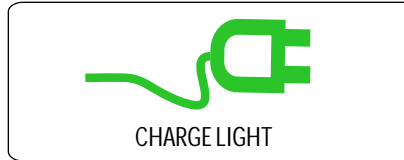

I. CHARGE LIGHT (Green)

In charge this light will flash every 2 sec's indicating batteries are charging & turns solid upon full charge.

NOTE
In case of any charge fault, charge light will be OFF with a message on cluster displaying CHARGE FAULT. please contact our service dealer for assistance.

NOTE

When vehicle is powered ON or OFF, some of lights on cluster glow for short time and is a part of Vehicle's self diagnostics. For any change in behavior please contact your Service centre.



II. PARKING BRAKE / LOW BRAKE FLUID LIGHT

- a) Solid: Indicates parking brake engaged. Release parking brake before driving your car.
- b) Flashing: Indicates Low brake fluid level with a message TOPUP BRAKEFLUID. Top up brake fluid with DOT-3 grade until maximum level & flashing light will go OFF.

5.4 INDICATOR LIGHTS

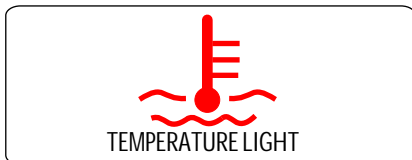

III. TEMPERATURE LIGHT

This indication comes on blinking or solid in driving/charging, indicating any of below components having reached their maximum operating temperature.

1. Battery
2. Charger
3. Motor
4. Motor controller

- a) Flashing temperature light indicates EV system temperature either too low or high for normal usage.
- b) Solid temperature light indicates EV system temperature reaching its max normal operating temperature.
- c) During drive -
Solid light with message SLOW CAR, avoid harsh driving with high acceleration.
Flashing light with message STOP CAR- stop the car for few minutes until light goes OFF.

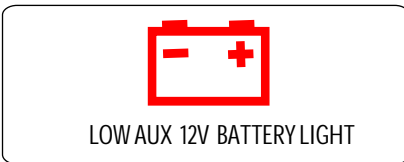
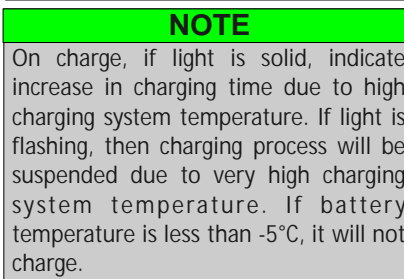
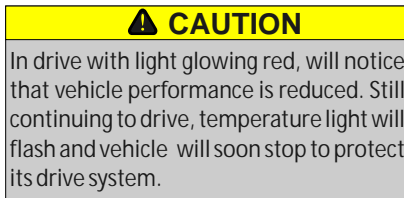

IV. LOW AUX 12V BATTERY LIGHT

Light turns on solid once this battery voltage goes very low.



V. EV WARNING LIGHT

EV warning light indicates system faults with fault message on cluster. It also indicates messages to user which can be read by pressing & holding SET button for 5 sec's to view messages. Press SET button again to view more messages.



VI. SERVICE LIGHT

This indicates

- a) Service due- Flashing light for 20 sec's in every drive after charge.
- b) Charge / Drive system faults- Solid light.

5.4 INDICATOR LIGHTS / 5.5 SPEEDOMETER & ODOMETER



DOOR OPEN LIGHT

VII. DOOR OPEN LIGHT

It indicates driver or passenger side door or hood or hatch is open. It will be off once they are closed properly.



SEAT BELT LIGHT

VIII. SEAT BELT LIGHT

It indicates seat belt light ON when driver side seat belt is not worn in drive.



ANTI THEFT LIGHT

IX. ANTITHEFT LIGHT

After successful locking, car will enter into immobilized state & this LED will blinking in cluster.

5.5 SPEEDOMETER & ODOMETER

Digital speedometer will display vehicle speed either in kilometers or miles based on prior selection.

I. ODOMETER

Odometer records & displays total distance in Kilometers or miles covered by vehicle.

ODO 000000 km
TRIP A 000000 mile

II. TRIP METER

Trip A displays kilometers covered in current drive and gets reset once car is put on charge.

Trip B can be used to measure distance traveled on short trips between stops.

Display Length

Total - 0 to 99999 Kms

Trip A- 0.0 to 6553.5 Kms (resets to zero when put on charge every time after drive)

Trip B- 0.0 to 6553.5 Kms

◀ Odometer will be displayed by default at every key ON.

CAUTION

Keep track of your odometer reading and check maintenance schedule regularly for required services. Increased wear or damage to certain parts can result from failure to perform required services at proper mileage intervals and your warranty rights may be affected.

NOTE

In drive, on cluster message center it displays either cabin or ambient temperature for a minute and will keep toggling between them.

5.6 MODE & SET BUTTON / 5.7 EFFICIENCY / 5.8 SOC & BAR GAUGE

5.6 MODE & SET BUTTON

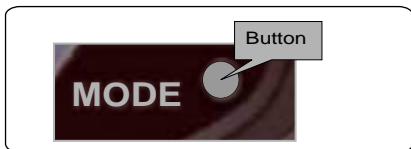

- ▶ Press mode button to toggle between ODO, TRIP A or TRIP B.
- ▶ In ODO selection, press & hold for 2 seconds to toggle between kilometers & miles.
- ▶ TRIP B selection, Press & hold for 2 seconds to reset present value to zero.
- ▶ TRIP A, displays present drive cycle mileage & resets to zero when put on charge.

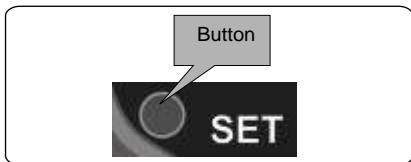

- ▶ Press SET or MODE button to turn on cluster illumination.

- ▶ Press & hold SET button for 5 seconds to read messages, if EV warning light is on. press again to read more messages.

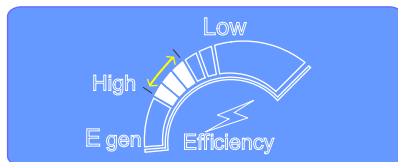

5.7 EFFICIENCY INDICATOR

Efficiency gauge indicates energy consumption level during drive. Above figure indicates good drive efficiency.

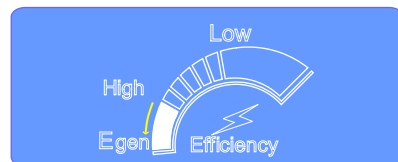

Above figure indicates regeneration of energy during drive. By anticipating & applying gradual braking will ensure battery will be recharged for extra range.

5.8 DIGITAL SOC & SOC BAR

- ✍ Indicates 'State of charge' in digital & bar display.
 - ✍ Displays all bars if SOC >95%
 - ✍ Lowest bar will start flashing if SOC drops below 5% charge.
- (Refer chapter 9.0 on " Starting & Driving" for more information).

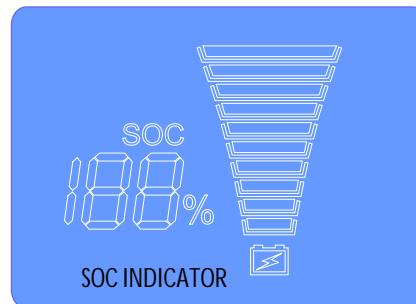

5.9 DTE & TTC INDICATOR / 5.10 WIND SCREEN WIPER & NOZZLE

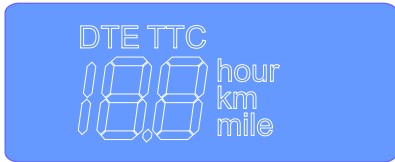

5.9 DTE / TTC INDICATOR

DTE- Distance To Empty :

Indicates approximate number of kilometers that can be driven with available charge.

TTC- Time To Charge:

Indicates approximate time to full charge.

NOTE

DTE is linear in normal drive speed of 50-60 km/hr. In event of drive with higher power consumption / harsh drive, actual initial DTE shown and kilometer driven will vary, however last 10% charge will show the exact DTE that can be travelled.

5.10 WINDSCREEN WIPER

To operate windscreen wiper, turn lever from OFF position to any of below operating positions in drive.

Position 1: Intermittent wiping speed

Position 2: Low wiping speed

Position 3: High wiping speed

- ✎ Pull lever downward for intermittent operation.
- ✎ Push lever upward for low & high wiping speeds.

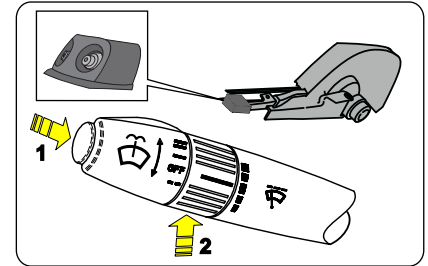
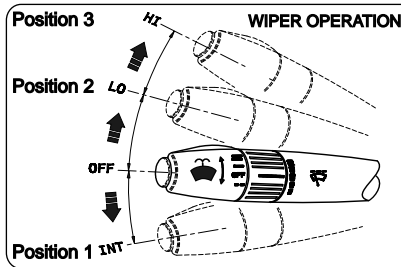

WINDSCREEN WASHER NOZZLE

To spray windscreen washer fluid, press button 1 on the lever, fluid will get sprayed through nozzles on wiper blades and wipes off screen for three wipes and then after 3 seconds with a single wipe.

To increase wiper wiping speed rotate knob 2 on wiper lever forward and to reduce rotate back.

NOTE

In sub zero ambient conditions, use anti freeze liquid in wind shield washer tank.

5.11 GEAR LEVER & DRIVE MODES



5.11 GEAR LEVER & DRIVE MODES

Gear lever enables you to choose your desired drive direction.

It has following positions:

Forward [F]: (Range mode)

Press gear release button to move lever from 'N' to 'F' mode. This is normal driving mode position to drive in forward direction (max speed is 80kmph) and driving in this mode will give best drive range.

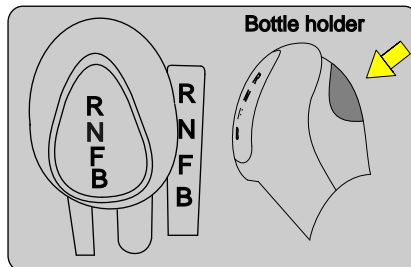

Power Boost [B]: (Power mode)

This position also enables you to drive in forward direction with quick acceleration & to overtake during drive.

Neutral [N]:

Always park your car in 'Neutral' position before turning off STOP button.

Reverse [R]:

Press gear release button to move lever from 'N' to 'R' mode. Gear lever moved to this position, car will drive in reverse direction with beep and speed is limited to 20 Kmph. Use reverse park camera* with infotainment system for assistance. *(To know more about how to get maximum range, please refer to Chapter 9.0 on "Starting & Driving")*

NOTE

Button on 'RNFB' is child safe mode switch to avoid unintended operation. Lever may not move from forward to reverse when button is kept depressed for long, hence do operate by depressing it after 2-5 seconds idle time.



GEAR DISPLAY

Neutral mode indication:

1. 'N' indication remains solid during key on when gear is in neutral position.
2. Modes 'B', 'F' Or 'R' will flash during key on when gear is not in neutral position. After authentication process push gear to 'N' position to enable power to drive system.

5.12 GLOVE BOX & BOTTLE HOLDER



Boost mode indication:
It will be on with gear lever is at 'B' position after key ON .



Forward mode indication:
It will be on with gear lever is at 'F' position after key ON.



Reverse mode indication:
It will be on with gear lever is at 'R' position after key ON with beep.



Economy mode indication:
a) When SOC drops below 20%
b) When EV system temperature reaches minimum set limit.
c) In this mode driving power will be limited.



Limp home mode indication:
a) When SOC drops below 10%
b) When EV system temperature reaches maximum set limit.
c) In this mode driving power will be limited with an indication 'POWER SAVE MODE" on cluster and air conditioning will turn off automatically.

5.12 GLOVE BOX & BOTTLE HOLDER
Instrument panel houses glove box that can be used for storing small things like CD, user manuals, spectacles etc. Door inner panels have a slot for storing water bottle.

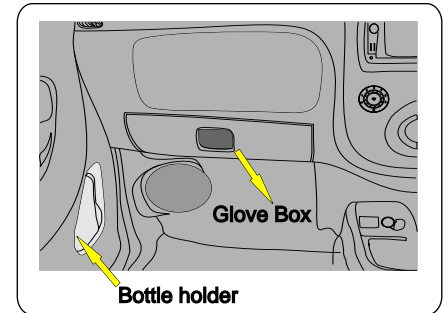

5.13 ACCESSORIES

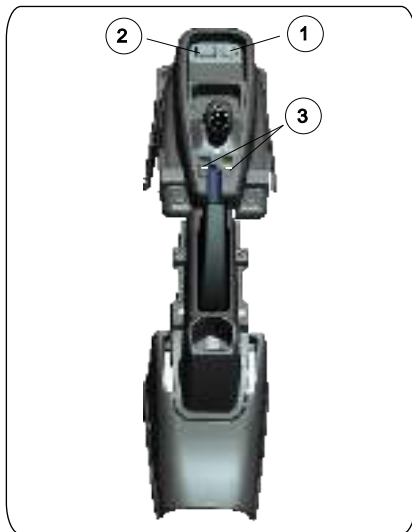

1. 12 V socket
2. USB port / Aux 2 in
3. Power window switch LH and RH

5.13 ACCESSORIES:

12V Socket :

Center console is equipped with a 12V power socket for charging laptop, mobile and other applications which consumes less than 100 watts.

USB Port:

USB port can be used for playing audio and video files from USB, IPOD when connected to port. (System may not support some of USB makes that are not from standard regular manufacturers. Refer "Infotainment and Navigation manual" for more information.

Aux 2 in:

Aux 2 in- can be used to connect IPOD, camera, game consoles, walkman and compatible other playing devices with respective cables. It will be available only when unit is connected with external A/V device, otherwise prompt shows "No signal input".

Power window switch:

Driver and passenger doors are equipped with power window. Push switch down to lower glass and lift up to raise glass.

CAUTION

- Leaving children, helpless adults, pets in car with windows closed is dangerous as it can overcome by extreme heat and suffocation / injury or even death from heat stroke.
- Never leave them alone with keys available as they can operate car unintentionally and cause damage.
- While raising power window glass, do make sure that no keeping hand / fingers (specially children) on window glass as it may hurt and result in injuries in operation.

NOTE

12V socket has been designed for charging gadgets like mobile phones and laptops. Using gadgets drawing heavy current can blow fuse and damage system.

5.14 INFOTAINMENT SYSTEM*

INFOTAINMENT CONTROLS:

1. Reset button
2. Disc change button
3. Return to Main menu
4. Navigation key button
5. Display screen
6. Switch on / off & Volume button
7. Navigation card slot
8. Micro SD card slot
9. Aux In socket
10. Disc player

The vehicle if equipped with "Infotainment & Navigation system" the above functions can be performed in vehicle. Refer "Infotainment & Navigation manual" for all information on operations and using this feature prior to first drive.



AUDIO SYSTEM*

Infotainment system is provided in selected models, is governed by its separate User's Manual.

6.1	Climate controls.....	49
6.2	Air flow vents.....	50
6.3	Air flow modes.....	50
6.4	Blower.....	50
6.5	Recirculation mode.....	51
6.6	Cooling.....	51
6.7	Demister.....	51
6.8	Heater.....	52
6.9	Rear defogger.....	52

6

CLIMATE CONTROL SYSTEMS

6.1 CLIMATE CONTROLS

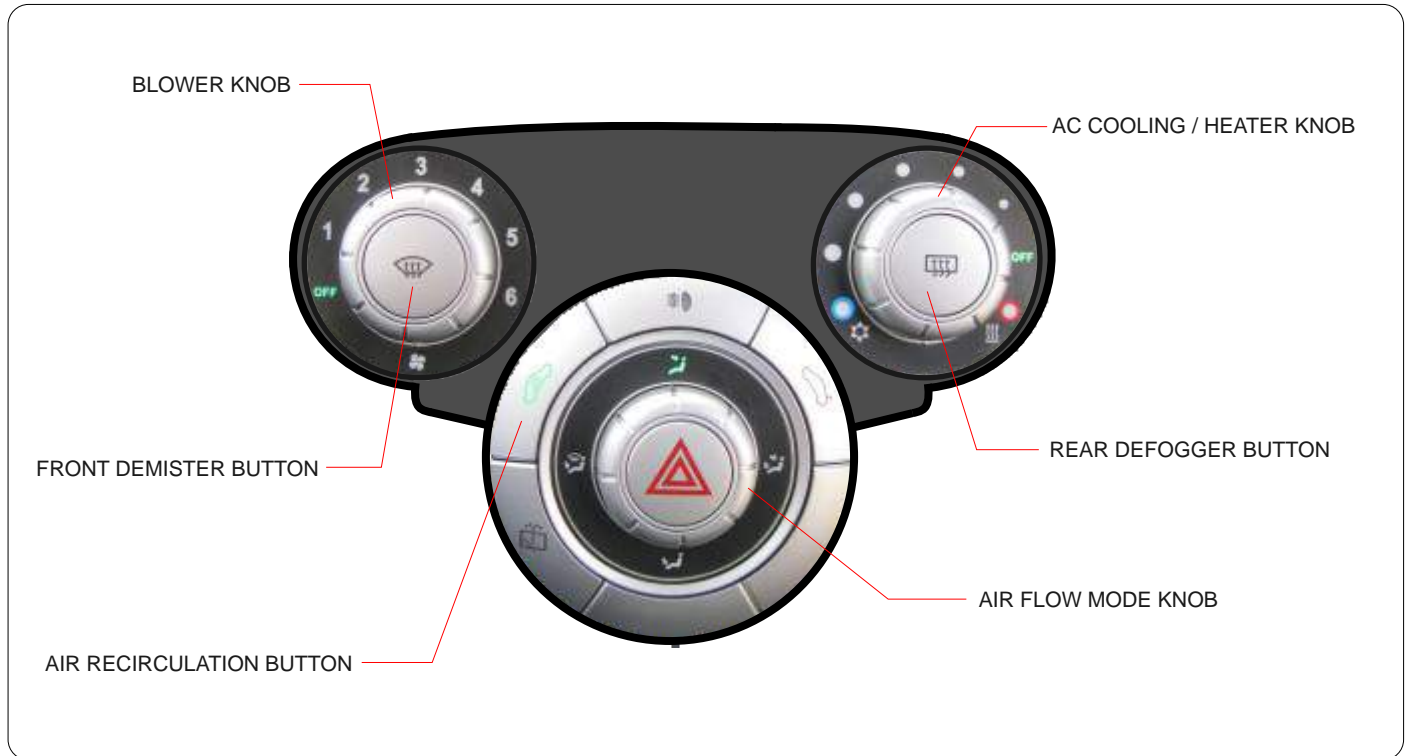

6.2 AIR FLOW VENTS / 6.3 AIR FLOW MODES / 6.4 BLOWER

6.2 AIR FLOW VENTS

Vehicle is equipped with a blower system with air flow vents provided to circulate air at locations within vehicle.

1. Central (circular) Louvers direct air towards cabin.
2. Vents near windshield directs air towards it.
3. Louvers & vents at two corners of dashboard directs air at sides and on to windows.

Louvers at centre & sides can be adjusted to direct air for better comfort.

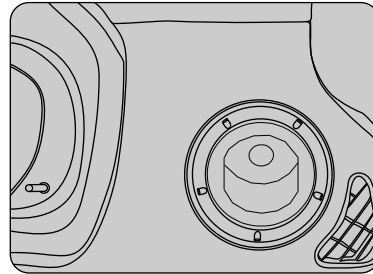
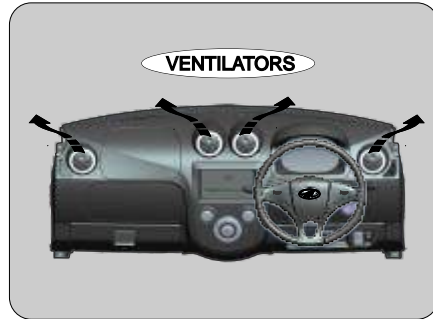

6.3 AIR FLOW MODES:

Air flow from blower can be adjusted to 4 different positions for your requirements by rotating knob clockwise to any of shown positions on climate control. By default air flow mode will be in position 2 when turned on at key on.

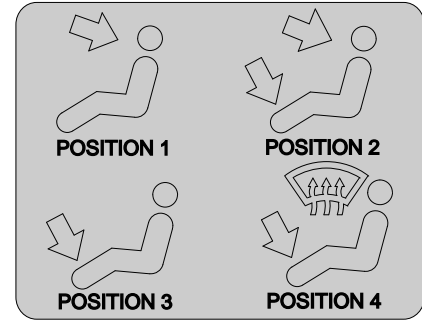

6.4 BLOWER

Blower can be turned on by rotating knob clockwise from OFF position to any of 6 positions to vary air flow.

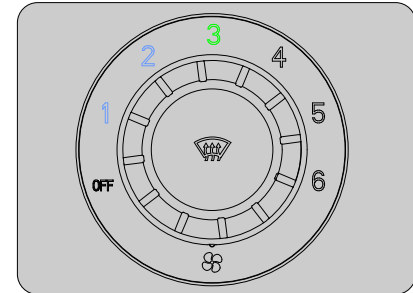

6.5 RECIRCULATION MODE / 6.6 COOLING/ 6.7 DEMISTER

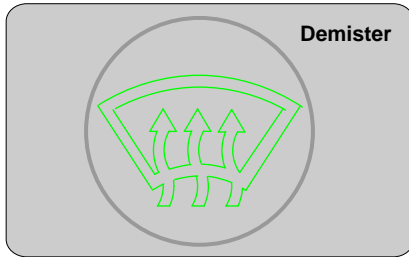

6.7 BLOWER- DEMISTER

Front wind shield glass demister is turned on to clear fog by pressing button once on blower knob. Press again to turn off demister.

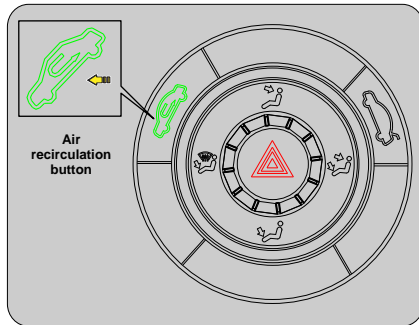

6.5 AIR RECIRCULATION MODE

Car will be in recirculation mode by default in key on condition. Turn OFF this button to enable fresh air mode.

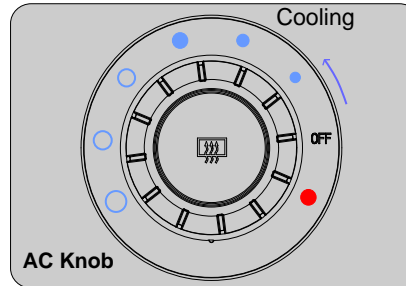

6.6 COOLING

- Turn AC knob in anticlockwise direction to switch on air condition.
- Turn knob to desired cooling position to your comfort level.
- Cooling will be turned off when SOC drops below 10%, while blower remains ON and is indicated by blinking of cooling position LED.

NOTE

- HVAC starts with high blower speed and maximum compressor speed for a minute at start and resets to selected position afterwards. To set it to your comfort, rotate the blower mode to required position.
- Use lower setting on the blower & AC knob to optimize cooling to your requirement.

CAUTION

- Do not leave children or adults or pets requiring attention / support in vehicle, as with doors & windows closed in hot / sunny days, temperature inside vehicle cabin could become high and cause suffocation to people / animals, could injure and result in death.
- Avoid using recirculation mode for longer periods as it can result in air becoming stale & fog up window panes.

6.8 HEATER / 6.9 REAR DEFOGGER

6.8 HEATER

To operate Heater:

- Rotate knob from off position in clockwise direction. 'Heater' symbol will come on and warm air will flow from vents based on mode selection.
- Heater will get switched off once the SOC reaches 10% while blower continues to operate and will be indicated by blinking 'HEATER' LED.

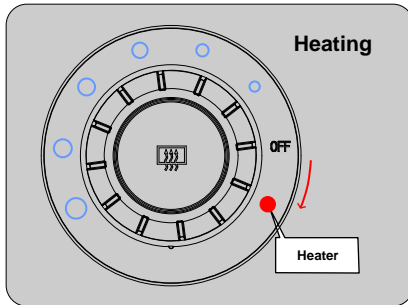

NOTE

Heater will not operate when SOC is less than 10% and goes into 'power save mode'.

6.9 REAR DEFOGGER

Rear hatch defogger is switched on to clear fog on rear hatch glass by pressing button once on AC & Heater knob. Press again to turn off rear defogger.

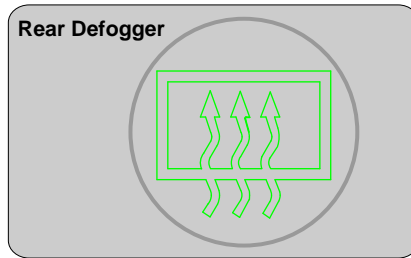

NOTE

Always remember to turn OFF Defogger switch once hatch glass gets cleared OR it gets turned off automatically after 15 mins of continuous operation.

7.1	My car info	55
7.2	Efficiency.....	55
7.3	REVive.....	56
7.4	Eco setting and Appreciation.....	58
7.5	Mobile App.....	58

7

MY CAR INFO and MOBILE APP

7.1 MY CAR INFO* / 7.2 EFFICIENCY

7.1 MY CAR INFO:

Using "My car info" by infotainment system, below features can be accessed.

1. State of charge
2. Distance to empty (DTE)
3. My car drive
4. My car regen
5. My car Idle
6. Drive efficiency
7. REVive
8. User info- Guide & Manuals
9. Eco setting
10. Eco drive score



Switch on infotainment system after key on & select 'My car' on touch screen to access 'My car information'.

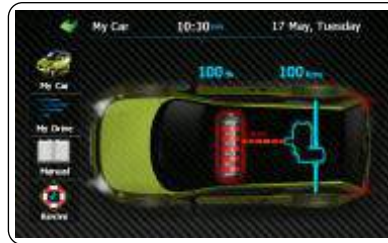

In 'My car information'. You can see state of charge (SOC), Distance to empty (DTE) and available energy for drive. Battery in red indicates energy consumption by drive motor.

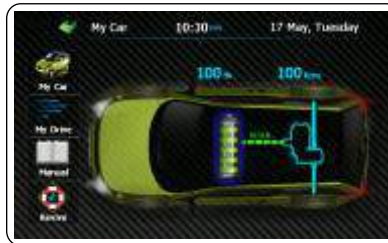

Battery in green indicates energy getting regenerated in drive.

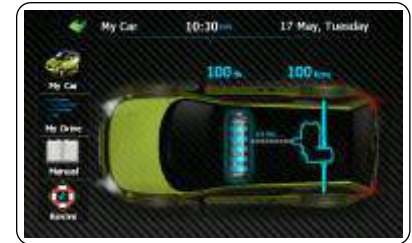

This screen displays that vehicle is idle and no consumption of energy.

7.2 Efficiency:

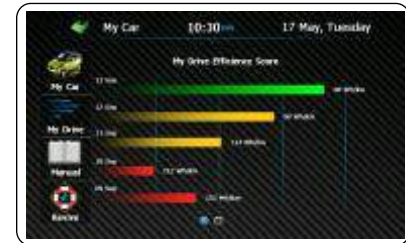

This screen displays power consumption per kilometer drive in last 5 drive cycles.

7.3 REVive*



REVive* is a feature to enable reserve energy when you run out of charge.

1. REVive is activated if SOC is <10%
2. REVive can be activated by infotainment system.

To activate:

- a) Select 'Gear Lever' to neutral.
- b) Select press to REVive

REVive will get activated with revived SOC and DTE



For unsuccessful attempts it will display any of below messages.

1. REVive time out
2. SOC greater than 10%
3. REVive already set
4. Vehicle not in neutral
5. Vehicle not authenticated
6. REVive limit exceeded
7. Vehicle de-activated
8. Drive stop fault

Try again with valid set conditions.



Try again to enable 'REVive' within time limit with set conditions.

NOTE

Please note that 'REVive' feature can be enabled with limitation and user charges as applicable.



Try again once 'SOC' becomes less than 10% to enable 'REVive'.



If 'REVive' is already activated and enabling again will display above screen. Wait till you observe 'REVive' successful display.



Shift gear lever to neutral mode and try again to enable 'REVive' with other set conditions.



Authenticate vehicle and try again to enable 'REVive' with other set conditions.



This screen displays that 'REVive' cannot be done as number of 'REVIVE' used in vehicle have crossed limit.



For vehicle deactivated message while activating 'REVive' Contact Technical help desk for support and assistance.



For drive stop error message while activating 'REVive', contact Technical help desk for support and assistance.



By accessing 'manual' menu you can access user manuals & trouble shooting guide.

7.4 ECO SETTING & APPRECIATION / 7.5 MOBILE APP



It can be used for setting "Eco" and see fuel saved. To get to this screen slide previous screen upwards.



It helps on improving driving habits, litres of fuel saved and improve.

7.5 MOBILE APP:

Vehicle is equipped with 'Mobile app' that can help user in planning his drive / charge and enabling some of features and operations mentioned below. Please check if your mobile is a smart phone for using this feature.

1. Lock & Unlock
2. Start & stop 'Air Conditioning'
3. Start & stop 'Charging'
4. Schedule 'Air Conditioning'
5. Activate 'REVive'
6. Trip planner
7. Search 'Nearest charging points'
8. Enable 'Vacation mode'
9. Assistance



Mobile app main menu screen display showing all features.



1. Lock & Unlock:
Using this feature you can lock and unlock your vehicle remotely. Tap at center to lock or unlock.



2. Start & Stop 'Air conditioning':
Using this feature you can keep your car cabin pre-conditioned by remote for convenience and activation depends on cabin temperature at that time.

Operation:

Remote pre-conditioning will get activated when enabled if cabin temperature is below 18°C or above 21°C. If cabin temperature is below 18°C, heater will come on and will cut off once temperature goes above 18°C and similarly if cabin temperature is above 21°C, cooling will start and will stop once temperature falls below 21°C. In event of very high or low cabin temperatures, cooling or heating will come on for 25 minutes for optimisation.

Plugged in:

Keeping car plugged in on charge, pre-conditioning of car cabin will be done by utilising power from mains and also keeps battery pack in full charged for your journey.

Unplugged:

In unplugged condition it consumes energy from your battery pack and drive range will be reduced.

NOTE

Pre-conditioning enabled will get turned off once the car is unlocked and doors opened.

7.5 MOBILE APP



3. Vehicle energy indication:

This screen shows present state of charge & distance to empty. Using this you can start and stop vehicle charging process remotely.

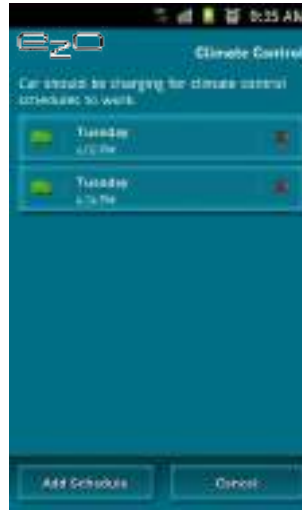

4. Schedule 'Air Conditioning':

Vehicle air conditioning can be scheduled for days of the week with time. You have to go to above screen in your mobile app and add schedule as per your requirement and save it. Working of heating / cooling depends on car cabin temperature.



5. Activate 'REVive':

This feature can be enabled when your battery power is less than 10% SOC. Going to above screen with preset conditions you can enable reserve energy with applicable user charges.



While activating 'REVive' feature ensure that SOC is less than 10%, vehicle is in 'Neutral' position after key on and authentication.



6. Trip planner: Using this feature you can plan your trip with any / all possible routes.



Going to this menu you can see and check where in it can be one way or possible round trip with available energy. Green circle shows that with available energy, 'Round trip' can be done and 'Red' shows it can be only one way trip and you have to charge in between to come back.

7.5 MOBILE APP



7. Search 'Nearest charging points':
Going to this screen you can check near by 'charge points / stations'.



8. Vacation mode:
If vehicle is not be used for more than 1week, enable 'Vacation mode' and save battery from idle discharge.
For doing so:- Select date, time from and to and save it in above screen.

Operation of vacation mode:

Car on charge:

- ✍ Car will charge or discharge till SOC reaches to 50% at start date /time and maintains SOC at 50%.
- ✍ On end date /time, car will come out from vacation mode and charge to 100% SOC and then onwards if not used it will be on trickle charge to maintain energy level.

Car Idle:

- ✍ If car is charged 100%, at start date / time, car battery will discharge till 50% and stays in vacation mode.
- ✍ If SOC is less than 50%, vacation mode gets activated at start date / time and stays in vacation mode with same SOC.

NOTE: In idle condition, to activate car from vacation mode, user has to open door by key, open data port cover using screw driver and keep reset button depressed for more than 30 seconds. And then put car on charge to 100% before use. Or else user can plug in car for charge, but keep power switch off, so that after completion of vacation mode, just simply switch on to activate car and allow car to charge full before using it.



9. Assistance:
With this feature you can avail on road assistance, access trouble shooting guide & also videos.

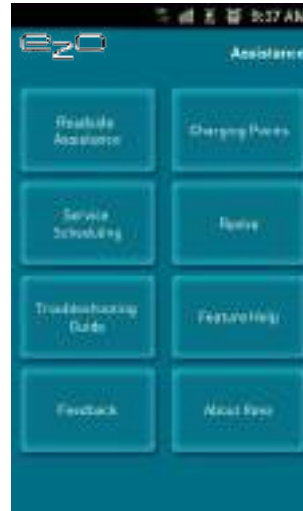

You can access above menus, request for 'Road side assistance', plan 'service scheduling', use 'trouble shooting guide' and also send 'feedback'.



You can access above sub menu and do possible trouble shooting. Upon selecting video, it starts streaming from web and display.

8.1	Key fobs and keys.....	65
8.2	Key fob operation.....	65
8.3	Chime.....	65
8.4	Door Locks.....	66
8.5	Hazard Warning.....	66
8.6	Horn.....	67
8.7	Mirrors and Adjustments.....	67
8.8	Head light adjuster.....	67
8.9	Sun Visor.....	68
8.10	Roof light.....	68
8.11	Brakes.....	68
8.12	Wiper washer.....	69
8.13	General checks.....	69

8

PRE DRIVE CHECKS

8.1 KEY FOBS & KEYS / 8.2 KEY FOB OPERATION / 8.3 CHIME

8.1 KEYFOBS & KEYS

Car comes with two identical key fobs with keys. Key fobs used to lock / unlock vehicle, authenticate to start car, open rear hatch and find car in parking lot.

In event of any loss or theft, in order to provide a new set of key fobs by service center, it is suggested to note down vehicle key tag details and keep it in a safe place. Always provide key tag number to service center, given with keys at the time of new car delivery for duplicate key request.

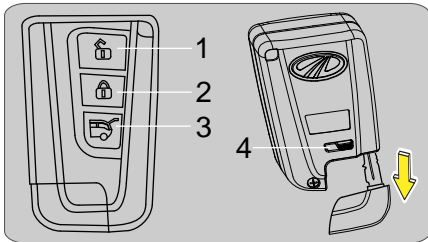

8.2 KEY FOB OPERATION

Button 1 : Press once to unlock vehicle (Unlocks with 2 flashes & beeps).

Button 2 : Press once to lock vehicle & twice within a second for vehicle search (Locks with 1 flash & beep).

Button 3 : Press & hold for a second to open rear hatch.

Button 4 : A sliding button is given at back side of fob for removing key from fob in emergency door lock access.

CAUTION

- Always lock / unlock using remote with a clear view of car.
- As a user do switch off START button, engage park brake, lock car & keep key fob in your pocket while exiting out of car.
- In event of failed remote system when locked, use hatch release button on HVAC controls or in emergency remove grommet on rear trim and pull release cable to release rear hatch.

8.3 CHIME

Chime comes on under following circumstances:

- Park brake pulled with Door open during drive (Beeps at every 1 sec).
- Park brake pulled with accelerator pressed (Beeps at every 1 sec).
- Park brake not pulled & door open in all modes (Beeps at every 1 sec).
- Brake fluid low (Beeps at every 1 sec in charge & drive).
- Continuous chime when EV system temperature reaches its maximum operating limit.
- 5 Second beep can be heard during automatic drive mode change to economy, limp home, safe mode, charge fault & drive fault.

8.4 DOOR LOCKS / 8.5 HAZARD WARNING

8.4 DOOR LOCKS:

I. TO LOCK/UNLOCK MANUALLY:

To lock or unlock your car manually in event of central locking inoperative, turn key in clockwise or anti-clockwise direction respectively as shown in figure.

To lock LH door from inside, push door lock lever forward and push it backward to unlock as indicated in figure.

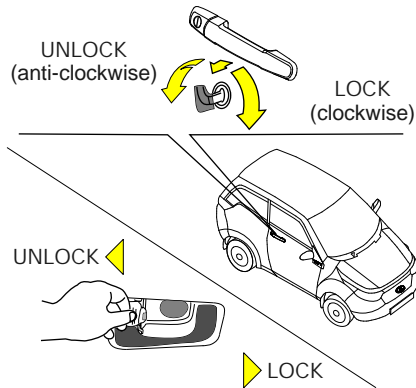

II. TO OPEN DOOR:

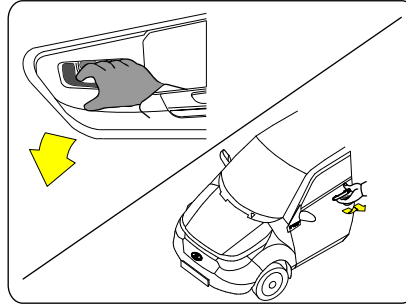

NOTE

Your car has been equipped with factory fitted central door locking (CDL) system. Hence keys must be used to lock/unlock doors in emergency when CDL system is not functional. It is advisable to operate remote while car is within range, as vehicle's CDL system is of visual type (turn indicators flash) and with small audible (siren) type.

⚠ CAUTION

1. Always make sure to close doors properly before driving & after getting out of car.
2. Locking doors will guard occupants from being thrown out in case of accidental opening of a door.
3. Allow a gap of 2-5 sec's between multiple operations of remote.

8.5 HAZARD WARNING

Press switch to activate hazard warning lights. All six external turn signal indicators will flash simultaneously. To turn off lights, press switch once again. This should be used to warn traffic in event of any emergency.

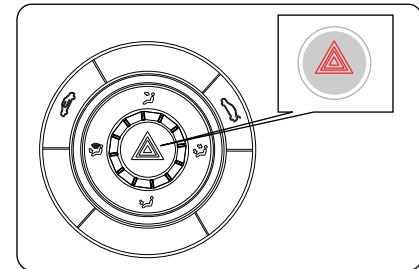

8.6 HORN / 8.7 MIRROR ADJUSTMENT / 8.8 HEAD LIGHT FOCUS SWITCH

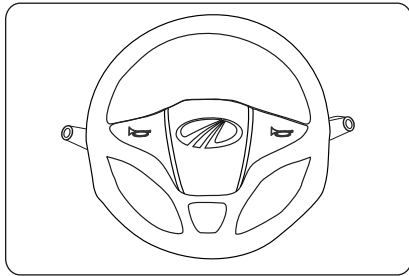

8.6 HORN

Horn operation is integrated in center pad of steering wheel. Press anywhere on this pad to sound horn.

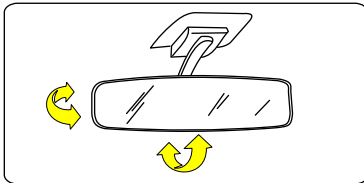

8.7 MIRRORS

Keep inside and outside mirrors clean & adjusted for better visibility. Be sure to adjust mirrors before you start driving.



SIDE MIRROR ADJUSTMENT:

Both side mirror's can be adjusted electrically for positioning mirror for better view of vehicles behind.

- ▶ Select right or left side mirror using upper switch.
- ▶ Adjust mirror to your driving position using lower switch.

NOTE

Interior and side mirror adjustments also to be used for night driving to avoid glare caused by vehicles coming from behind.

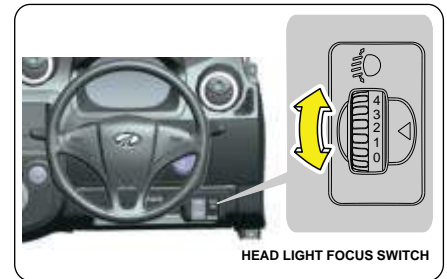

8.8 HEADLIGHT FOCUS SWITCH

Use scroll button on switch to fine tune head light low beam focusing as required before starting of drive.

- ▶ Scroll button up or down to adjust head light low beam focus of your car.

8.9 SUN VISOR / 8.10 ROOF LIGHT / 8.11 BRAKES

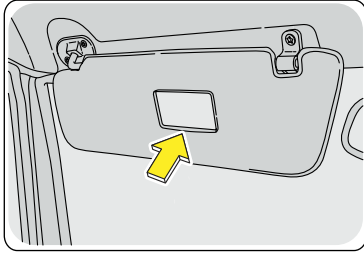

8.9 SUN VISOR

Two adjustable sun visors are provided in car for protection of driver and passenger against glare. In addition, passenger side sun-visor comes equipped with a vanity mirror.

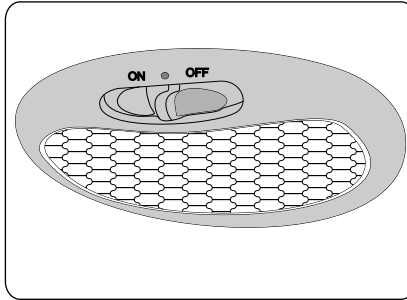
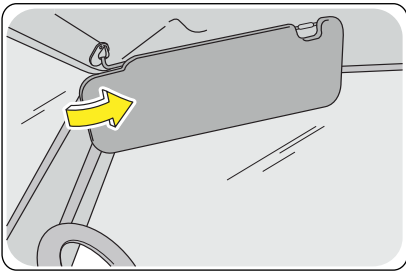

8.10 ROOF LIGHT

It has 3 positions:

Position 1 (off) :

Light remains off when door is open.

Position 2 (0) :

Light comes on when doors are opened & goes off when closed properly.

Position 3 (on) :

Light comes on regardless of whether door is opened or closed.

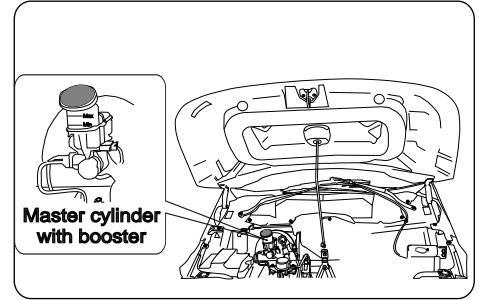

8.11 BRAKES:

Brake system in car works on hydraulic with vacuum booster assisted by regenerative brakes. This helps in lesser effort by user while retarding and have good braking. Electric vacuum pump helps in optimizing vacuum in booster. Check for proper working by applying brake before starting your drive.

8.12 WIPER WASHER TANK / 8.13 GENERAL CHECKS

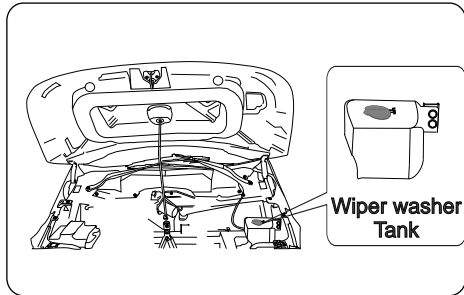

8.12 WIPER WASHER TANK:

A container for wiper washer fluid is provided under the hood. This is provided to clean / wash up wind shield glass in event if it is dirty from dust particles to have good visibility. Check for cleanliness of wind shield prior to drive.

8.13 GENERAL CHECKS:

Prior to starting of your drive do carry out a visual check for available energy is sufficient for your journey, all dash board lights are working OK, all tyre pressures are OK, Seat belts and lights / horn are working fine.

⚠ CAUTION

Appearance of EV warning light could be due to a temporary condition detected by IEMS (On board computer) and will turn off if problem gets healed. In case it continues to stay on contact service center.

9.1 Starting.....	71
9.2 Driving.....	72
9.3 REVive.....	73
9.4 Hill Hold.....	73
9.5 Extending Your Driving Range	73
9.6 Troubleshooting.....	74

9

STARTING AND DRIVING

9.1 STARTING:

Check energy level on SOC bar and digital SOC display. Ensure that there is enough charge for your immediate journey.

Eight simple steps to get your car started & ready to drive:

- Step 1: Turn off power supply and remove plug from wall socket.
- Step 2: Open rear hatch and unplug charge cable. Roll it & keep inside vehicle.
- Step 3: Unlock door using remote key fob.

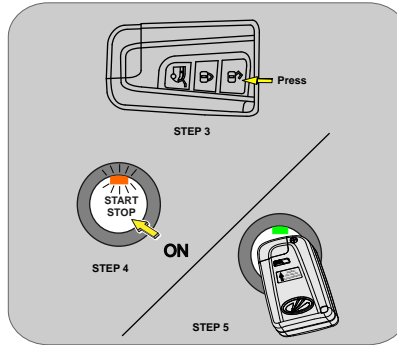
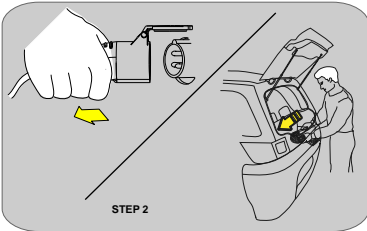
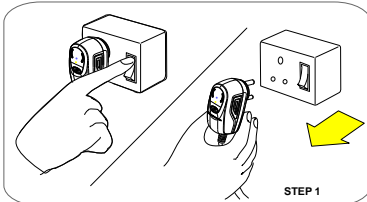

- Step 4: Turn on start button.
- Step 5: Authenticate key by placing key fob near to start button as shown above with position arrow on key fob.
- Step 6: Ensure seat belts are fastened.
- Step 7: By pressing gear release button, select gear lever to desired driving position.
- Step 8: Release parking brake, press accelerator pedal. Use only your right leg for applying accelerator & brake pedals.

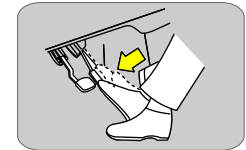
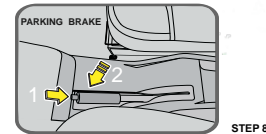
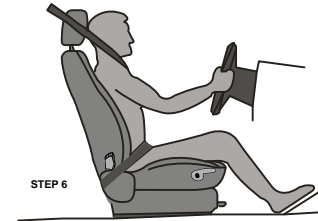

9.2 DRIVING

Step 9: When you require a higher acceleration to overtake other vehicles or in up-hill climbing, move gear lever to 'Boost' [B] mode. In this mode you attain a much higher torque. The max. speed is 81 kmph & It is possible for you to switch from Forward [F] mode to Boost [B] mode and vice-versa while car is in motion. However, for optimal driving range, you are advised to use Forward [F] mode.

Step 10: To reverse, make sure that your car is stationary. Then move gear lever to Reverse [R] mode. Press accelerator gently and drive backward. In this mode, speed is electronically limited to approx 20 kmph for safety.

By following above steps, you will see that driving your car is a simple and delightful experience. Read section 9.6 to get best performance from your vehicle.

Reverse park Camera:

Use 'reverse park camera' (if equipped) for assistance in reversing your car. This will come on as soon you select reverse mode with infotainment system ON.

When charge level in your battery Pack reduces to less than 10% SOC, vehicle energy monitoring system puts vehicle on "power save mode" where in car will drive in reduced power.

This is due to pre-programmed software in your vehicle's Intelligent Energy Management System [IEMS] and Motor Controller. These components will monitor, as far as possible, that you are never get stranded on the road due to insufficient energy in battery Pack. Digital SOC & SOC bar displays available energy and 'distance to empty' indicating your driving range from previous & present drive. As you cover distance, digital SOC & gauge bar will reduce continuously displaying possible drive range from remaining energy in battery pack.

NOTE

- ✎ In event of unsuccessful attempt of authentication within 60 sec's, cluster will display 'RESTART'. Press start button again & position key fob for authentication.
- ✎ Operate brake pedal and accelerator pedal with your right foot only.
- ✎ While driving, if you remove your foot from accelerator pedal without pressing brake pedal, you will feel partial regenerative braking. This is normal and is attributed to vehicle's regenerative braking that will re-charge batteries for an extra drive range.
- ✎ In event of 'START / STOP' button turned off, it takes few seconds for LED to turn from 'Green' to off condition and during this if you want to switch ON car, you simply press 'START' button again and does not require to authenticate again.

9.3 REVive / 9.4 HILL HOLD / 9.5 EXTENDING YOUR DRIVING RANGE

CAUTION

Always ensure energy level is sufficient for proposed travel distance. Avoid driving below 1% State of Charge as vehicle might stop at any point of time from now. Find nearest charge point to charge your car.

9.3 REVive*

In event of SOC is low (<10%) while in drive, you can activate reserve energy by activating "REVive". This will allow you to get energy released from battery reserve to reach your destination or near charge point. 'REVive' feature to be used in emergency, hence use 'REVive' feature carefully by planning your daily travel.

*: User charges as applicable.

9.4 HILL HOLD & RESTRAINT:

This feature allows you stop your car on inclined roads for few seconds after pressing and holding brake for a second. It gives an added advantage to user for having good control while driving on an incline.

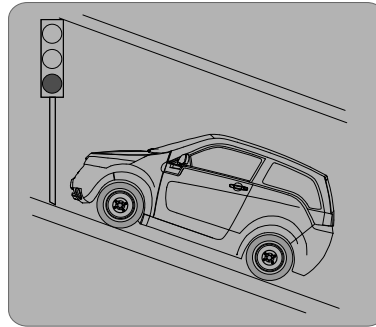

- To enable hill hold, press & hold brake pedal for 1 second.
- The car holds for 2 seconds & then slowly restrain backwards.
- To release car from hill hold or restrain, press accelerator or brake pedal.

9.5 EXTENDING YOUR DRIVING RANGE

- Always make sure that you release parking brake completely before driving your car.
- Always drive car using right foot only.
- Always drive in Forward [F] mode to get optimum range out of your battery. Use B mode when you want to overtake or when you want to have fun with car.
- Pre cool your car cabin remotely by turning on aircondition when still plugged in for charge. This will ensure that battery will be 100% charge with cabin temperature preconditioned.
- Use aircondition with desired level of cooling set during drive. This will help in consuming less energy for cooling.
- By anticipating and applying gradual braking you will ensure car batteries will be recharged for extra range. Vehicle is assisted with electrical regenerative braking, also vacuum assisted brake for shoot stop.

9.6 TROUBLESHOOTING

	PROBLEM	POSSIBLE CAUSE	REMEDY
i.	Start button pressed, car not turning on with 'UNPLUG CAR' message.	<ul style="list-style-type: none"> Charge cable may not be removed from on board charge port. 	<ul style="list-style-type: none"> Remove charging cable from car on board charge port.
ii.	Car not switching on with message 'AUTHENTICATE KEY' on cluster.	<ul style="list-style-type: none"> Authentication not done correctly. 	<ul style="list-style-type: none"> Place remote key fob near 'START' button for authentication.
iii.	Car not switching on with SHIFT GEAR TO 'N' message on cluster.	<ul style="list-style-type: none"> Car may not be parked in neutral. 	<ul style="list-style-type: none"> Switch on, authenticate, move gear lever to neutral and then to required mode.
iv.	Car not switching on with 'RESTART' message on cluster.	<ul style="list-style-type: none"> Car may not have authenticated properly. 	<ul style="list-style-type: none"> Restart again and start your car.
v.	Temperature Light comes on while driving with 'GO SLOW' message on cluster.	<ul style="list-style-type: none"> EV drive system temperature may have reached max. operating limit. 	<ul style="list-style-type: none"> Drive your car slowly and if on charge, stop charging and allow 15-20 minutes to cool.
vi.	Temperature Light comes on while driving with 'STOP CAR' message flashing on cluster.	<ul style="list-style-type: none"> EV drive system temperature may have exceeded maximum operating limit. 	<ul style="list-style-type: none"> Park your car at safe place. Engage parking brake. Wait for ~ 15 minutes till temperature light goes off and start driving / charging again.
vii.	Car stopped in drive with 'CHARGE CAR' message on cluster.	<ul style="list-style-type: none"> Charge level of battery has dropped to 0% SOC. 	<ul style="list-style-type: none"> Charge your car or activate REVive if available.

9.6 TROUBLESHOOTING

	PROBLEM	POSSIBLE CAUSE	REMEDY
viii.	Error message 'TOPUP BRAKE FLUID' and indication on cluster.	<ul style="list-style-type: none"> Brake fluid level may have gone low in master cylinder. 	<ul style="list-style-type: none"> Top up brake fluid with recommended grade to maximum level.
ix.	Car not driving per mode & throttle demand with 'GO SLOW' message.	<ul style="list-style-type: none"> Possible fault in EV drive system 	<ul style="list-style-type: none"> Drive carefully and request assistance from your dealer.
x.	Car not moving with 'DRIVE FAULT' message on cluster.	<ul style="list-style-type: none"> EV drive system having permanent faults. 	<ul style="list-style-type: none"> Contact your dealer for assistance.
xi.	Central door lock not operating with 'CHANGE KEY BATT' message.	<ul style="list-style-type: none"> Remote key fob battery voltage may be low. 	<ul style="list-style-type: none"> Replace key fob battery with recommended type.
xii.	Poor wiping action: (Wiper blade is not moving or is stuck on windscreen area.)	<ul style="list-style-type: none"> Blade improperly set. Windshield is dirty with oil. Wiper blade worn-out 	<ul style="list-style-type: none"> Adjust blade position. Clean windshield properly. Replace with a new blade.
xiii.	Immobiliser activated	<ul style="list-style-type: none"> Opening door manually with keys will activate anti theft alarm. 	<ul style="list-style-type: none"> Press 'UNLOCK' button in remote to deactivate.
xiv.	Hard Steering.	<ul style="list-style-type: none"> Low or uneven tyre pressure. 	<ul style="list-style-type: none"> Inflate to correct tyre pressure.
xv.	Vehicle pulls to one side while driving.	<ul style="list-style-type: none"> Low or uneven tyre pressure/ disturbed Wheel Alignment 	<ul style="list-style-type: none"> Inflate to correct tyre pressure. Check wheel alignment.

9.6 TROUBLESHOOTING

	PROBLEM	POSSIBLE CAUSE	REMEDY
xvi.	Steering Kickback: (While driving, you feel jerks and vibrations on steering wheel.)	☞ Low or uneven tyre pressure.	☞ Inflate to correct tyre pressure.
xvii.	Hard or Rough ride: (When you drive your car, you feel that ride is bumpy and rough.)	☞ Excessive tyre pressure.	☞ Inflate to correct tyre pressure.
xviii.	Wheel Wobbling: (While you drive, wheels and / or steering shake.)	☞ Incorrect wheel balancing and/or alignment.	☞ Contact an Authorized Service Centre and get wheels checked for alignment and balancing.

NOTE

If any of problems mentioned here persists even after you have attempted remedial measures mentioned above, please contact Authorised Service Centre.

10.1 Tyres	79
10.2 Tyre Pressure	79
10.3 Tyre Markings	79
10.4 Wheel Alignment and Balancing.....	80
10.5 Tyre rotation.....	80
10.6 Tyre and Wheel Inspection	81
10.7 Spare Wheel.....	81
10.8 Changing a flat Tyre	81

10 TYRES

10.1 TYRES / 10.2 TYRE PRESSURE / 10.3 TYRE MARKINGS

10.1 TYRES

Car is provided with tubeless tyres.

10.2 TYRE PRESSURE

Recommended Tyre pressure (cold fill) is:

FRONT - 32 PSI
REAR - 32 PSI

10.3 TYRE MARKINGS

Size Markings:

APOLLO tyres on the car are marked as:

APOLLO: 155 / 70 R 13 71 T

NOTE

Any under inflated tyre generates excessive heat that may result in reduced life of tyres.

Check inflation pressures on all tyres at least once in two weeks before driving. This should be done when tyres are cold.

Low tyre inflation pressure will result in higher rolling resistance and will have a negative effect on drive range.

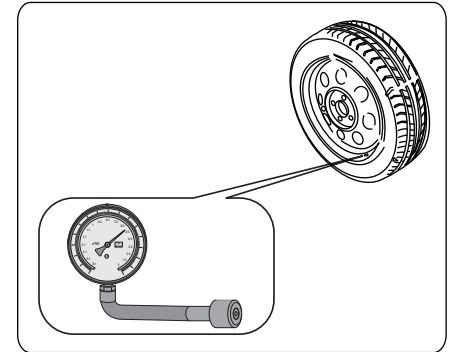

CAUTION

Tyres used are with special low rolling resistance, should be replaced with same type. Using any other tyres except recommended Apollo will result in reduced driving range.

All kind of repair/maintenance should be carried out by Authorised Service Center only. Failure to do so can result in tyre warranty being null and void.

NOTE

The tyres fitted in the vehicle meet the requirements of BIS and they would comply with the requirements under the CMVR 1989, as mentioned Notification SO 2953E

10.4 WHEEL ALIGNMENT AND BALANCING / 10.5 TYRE ROTATION

10.4 WHEEL ALIGNMENT AND BALANCING

NOTE

Wheel alignment and balancing are important for safety and to optimize drive range.

Check the wear on your tyres at least once a month.

If your tyres are wearing unevenly, e.g. inside shoulder of tyre wearing faster than rest of the tread, or if you detect excessive vibration, get your wheel alignment and balancing checked immediately. These conditions not only effect life of tyres but also adversely affect handling characteristics of car.

Replacement of tyre is needed when:

1. Wear indicators are seen at three or more places around tyre.
2. Cord / Fabric can be seen showing through tyres rubber.
3. Tread or sidewall is cracked, cut, or snagged deep enough to show cord or fabric.
4. Tyre has a bump, bulge or split.
5. Tyre has a damage, puncture or cut, that can't be repaired well because of size or location of damage.

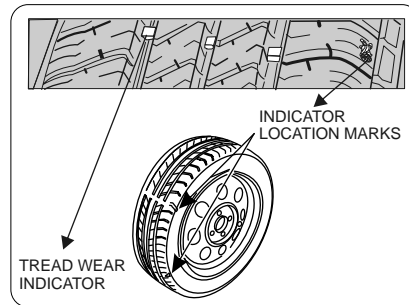

10.5 TYRE ROTATION

For uniform tyre wear, rotate tyres periodically as shown in figure. Purpose of tyre rotation at specified intervals is to get best mileage from all tyres in vehicle. First rotation is most important. When rotating tyres, always use rotation pattern as shown below. Make sure that wheel nuts are tightened to specified 70Nm.

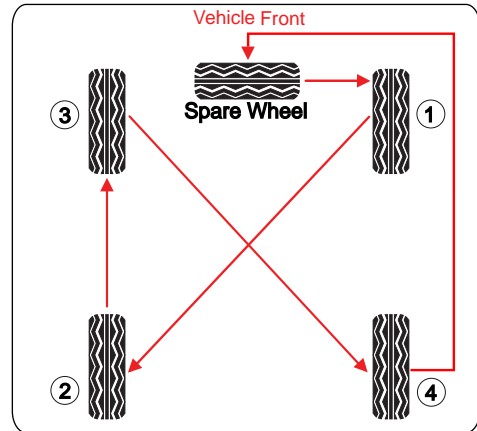

10.6 TYRE INSPECTION / 10.7 SPARE WHEEL / 10.8 CHANGING FLAT TYRE

While carrying out tyre rotation, check for damaged tyres & wheels. Also get a check on wheel alignment.

After every 30,000 kms vehicle usage, tyres need rotation. Periodic rotation of tyres will result in uniform tyre wear. It is however essential to get wheel alignment checked.

After tyres have been rotated, get tyre pressures adjusted to 32psi as indicated on door pillar.

10.6 TYRE INSPECTION

Hazards

Objects on the road, such as potholes, pieces of glass, metal, rocks, wood, debris, etc. can damage a tyre. These should be safely avoided at all possible times. Unavoidable contact with such objects should immediately be followed by a tyre inspection. Always look for bulges, cracks, cuts and abnormal tyre wear, especially on edge of tyre tread, which might be caused by a wrong alignment or under-inflation.

If any such damage is found, contact nearest Authorised Service Centre immediately.

10.7 SPARE WHEEL

All tyres in car are tubeless. Spare wheel has been provided under hood. Get air pressure of spare tyre every time other tyres are checked. It should be inflated to 32 psi. For tyre repair, contact your nearest Apollo tyre dealer. Alternatively, contact Mahindra Reva Service center or Customer Care.

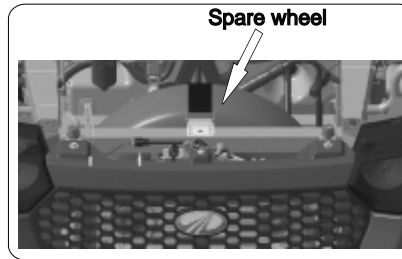

10.8 CHANGING FLAT TYRE

Follow 6 simple steps given below to change a flat tyre:

Step 1: Park vehicle on firm, level and non-slippery ground away from traffic. Shift gear lever to N (Neutral) mode. Engage parking brake, turn on hazard warning lights and turn off key switch. Have all passengers out of vehicle prior to changing flat tyre.

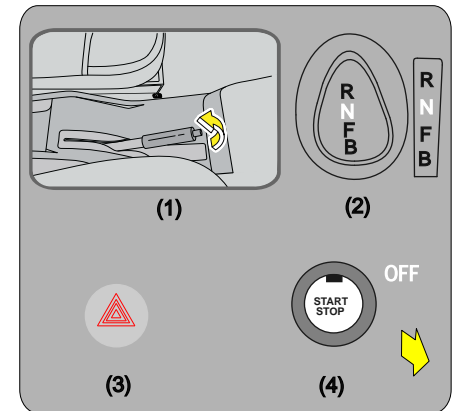

10.8 CHANGING A FLAT TYRE

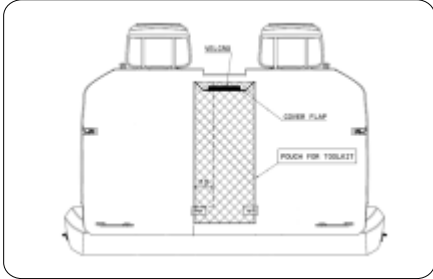

Tool kit is in rear seat back pouch as shown above and jack is provided at front under hood. Remove wheel spanner from tool kit and provide stopper to wheel parallel to flat tyre before Jacking up vehicle for changing wheel.

⚠ CAUTION

Car can roll off jack and seriously injuring anyone underneath. Follow directions for changing a tyre exactly and never get under vehicle when only jack supports it.

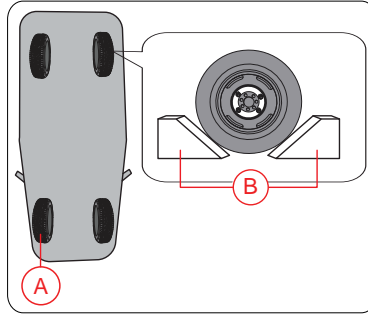

Step 2: Open hood (bonnet). Remove jack by unscrewing mounting nut. Remove spare tyre by unstrapping mounting belt.

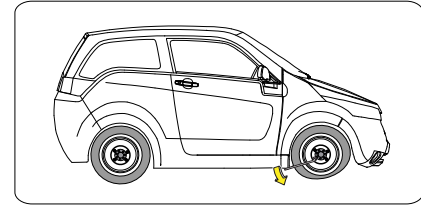
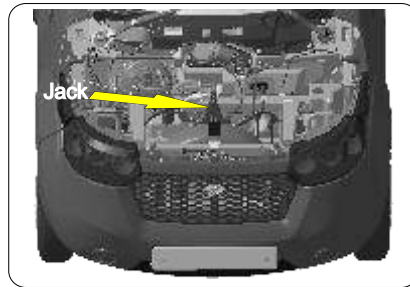

Step 3: If required remove hubcap by holding cap on top and tapping it gently. Loosen four-wheel nuts, ½ turn with wheel spanner. Locate jack point nearest to flat tyre you need to change.

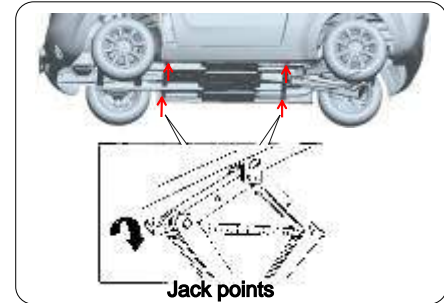

10.8 CHANGING A FLAT TYRE

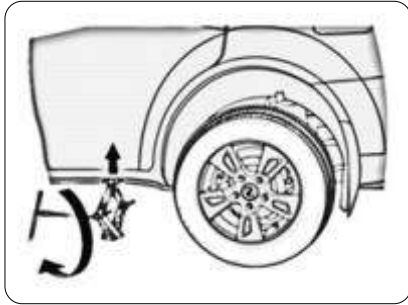

Step 4: Place jack under jack point. Turn end bracket clockwise until top of jack contacts jack point. Make sure jack point tab is resting in jack notch. Use jack rod to raise vehicle until flat tyre is just off ground. Remove wheel nuts and flat tyre. Temporarily place flat tyre on the ground with outside surface of wheel facing up. You could scratch wheel if you put it face down.

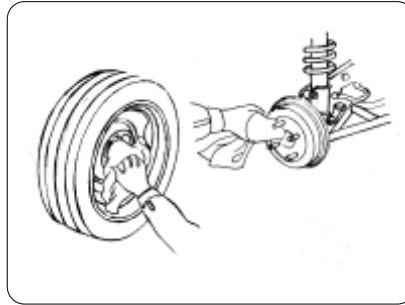

Step 5: Before mounting spare tyre, wipe any dirt off mounting surface of wheel and hub with a clean cloth. Wipe hub carefully, it may be hot from driving. Fix spare tyre, put wheel nuts back on finger-tight, then tighten them in a crisscross pattern with wheel spanner until wheel is firm against hub.

Step 6: Lower car to ground and remove jack. Tighten wheel nuts securely in same criss-cross pattern to recommended torque (70nm). Place flat tyre back in its position and strap tightly.

Adjust jack for correct position and fit it back to its location using mounting nut. And fix tool kit in its place behind rear seat. Re-fix hubcap by placing it in its original position and tapping it gently at center. Now vehicle is ready to drive.

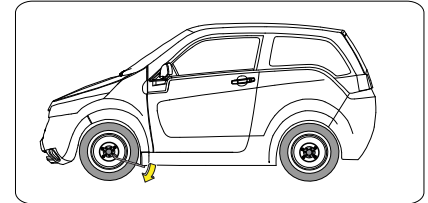
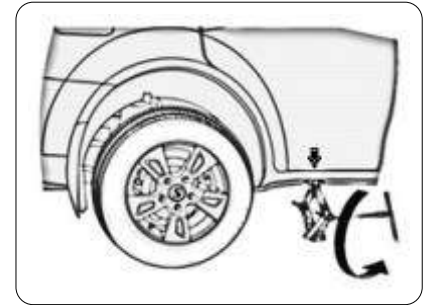

- 11.1 Accessories - Do's and Don'ts..... 85
- 11.2 Parking - Do's and Don'ts..... 85
- 11.3 Maintenance- Do's and Don'ts..... 85
- 11.4 Charging- Do's and Don'ts..... 86
- 11.5 Servicing-Do's and Don'ts..... 86
- 11.6 Driving-Do's and Don'ts..... 87

11

DO'S AND DON'TS

11.1 ACCESSORIES /11.2 PARKING / 11.3 MAINTENANCE

11.1 ACCESSORIES - DO'S & DON'TS

DO'S	DON'TS
<p>☞ Only recommended accessories should be installed through Authorised Service Centre.</p>	<p>☞ The customers should not install any electrical accessories. Unauthorised addition of electrical accessories can damage your vehicle and manufacturer warranty will become null and void.</p>

11.2 PARKING - DO'S & DON'TS

DO'S	DON'TS
<p>☞ Always engage parking brake while parking your car.</p>	<p>☞ Never leave the car without applying parking brake when parked.</p>

11.3 MAINTENANCE - DO'S & DON'TS

DO'S	DON'TS
<p>☞ Use a damp cloth or a soft brush to clean interiors of your car. ☞ Always keep your vehicle washed regularly to keep it to look new for a long time.</p>	<p>☞ Do not spray water inside your car as water can get inside electronic/electrical components.</p>

11.4 CHARGING - DO'S & DON'TS / 11.5 SERVICE - DO'S & DON'TS

11.4 CHARGING - DO'S & DON'TS

DO'S	DON'TS
<ul style="list-style-type: none">🔊 Inspect your charging cable periodically for any damage like cracks, cuts, exposed wire, etc. Replace if required.🔊 When charging process is over, first switch off power supply. Then remove charging cable from external Power Source and on-board charge port, in order. Roll up and store charging cable in its compartment behind rear seat.🔊 Make sure that children are kept away from power source & on-board charge port during charging process.🔊 When your car is not in use, keep it on charge.🔊 Allow battery Pack to charge completely whenever possible.🔊 Ensure proper earthing, over voltage protection, earth line circuit breaker has been provided to charging point.	<ul style="list-style-type: none">🔊 Do not charge your car if external Power Source and / or on-board charge port are exposed to rain or water.🔊 Do not carry out charging procedure with wet hands.🔊 Do not allow children or People having implanted medical electric devices near car while carrying out charging process.

11.5 SERVICE - DO'S & DON'TS

DO'S	DON'TS
<ul style="list-style-type: none">🔊 Get your car serviced at specified intervals as per recommended maintenance schedule in user manuals.🔊 Check Brake Fluid Level at least once a month. Have it topped up if low brake fluid light starts flashing.🔊 Car should be disconnected from power source before getting any services being carried out.	<ul style="list-style-type: none">🔊 Do not charge car while washing or cleaning.🔊 Do not use / spray water inside vehicle while washing / cleaning.

11.6 DRIVING - DO'S & DON'TS

DO'S	DON'TS
<ul style="list-style-type: none"> ▣ Always ensure right charge for right distance. Check SOC level on gauge before commencing a journey. ▣ Always wear seat belt while driving. ▣ Adhere to maximum payload is 300 kg for better acceleration, driving range and comfort. ▣ As far as possible, drive in Forward [F] mode. This will optimize your driving range. Accelerate moderately always. ▣ While driving during night, switch off head lights while idle at a traffic signal. This will help in conservation of energy & optimize driving range. ▣ Always maintain recommended tyre pressure for optimizing driving range, comfort and increased tyre life. 	<ul style="list-style-type: none"> ▣ Do not undertake drive when SOC level is very low. Driving at this stage might reduce life of battery pack. ▣ Avoid sudden acceleration and hard turns. This will consume more energy and thereby affecting driving range. ▣ Do not use accelerator pedal to hold car on an incline.

NOTE

Your vehicle needs special attention in below situations: Please contact your dealer service person for support.

- Charge Light stays on even after charge cable is removed or it does not come on when car is put on charge.
- EV warning light stays on in drive. (This can be due to temporary faults, check message on cluster & drive carefully).
- Service Light stays on in drive.
- IP cluster Light stays on after start up switch is turned off.
- Temperature Light solid after start up switch is turned on.
- Parking Light & Low brake fluid light stays on after parking brake is disengaged and there is adequate brake fluid.

12.1	Lights.....	89
12.2	Turn lights.....	90
12.3	Interior Light.....	90
12.4	Brakes.....	90
12.5	Tyres.....	90
12.6	Windscreen Washer.....	91
12.7	Wiper blade.....	91
12.8	Maintenance Schedule.....	92
12.9	Fuse box.....	94
12.10	Interior.....	96
12.11	Storing of car.....	96
12.12	Exterior.....	97
12.13	End of life- disposal.....	97

12 APPEARANCE AND CARE

12.1 LIGHTS

Check operation of your car exterior lights at least once a week. A burned out bulb creates an unsafe drive condition by reducing your vehicle's visibility and ability to signal indications to other road users.

Following check list will help:

1. Headlights (low and high beam)
2. Parking lights
3. Turn signals
4. Reverse lights
5. Number Plate light
6. Brake lights
7. All indicator / IP warning lights
8. High mount stop lamp

If you find any bulbs have fused, have them replaced.

NOTE

Rear Brake light, High mount stop lamp & IP cluster lights are part of assembly and for replacement assembly needs to be replaced.

REPLACEMENT OF BULBS

- Headlight:
 1. Open bonnet and engage support rod.
 2. Disconnect wiring harness connector from rear of bulb.
 3. Pull rubber cap out.
 4. Release bulb retaining spring and remove bulb.
 5. Replace bulb with a new one.
 6. Install in reverse order of removal.
When installing new bulb, ensure that lugs on bulb holder engage correctly in recesses of housing.
 7. Install rubber cap correctly in place.
 8. Connect connector to rear of bulb.

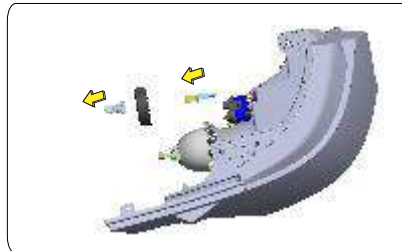

CAUTION

Greasy hands/fingers will cause stains, resulting in dull and inefficient light. Do not touch bulbs with bare hands. Clean with a non fluffy cloth using spirit.

NOTE

- ✍ Inside of head light lens may get clouded immediately after washing your car. This moisture condensation inside head light lens will disappear gradually as it gets warmed up by head light. In this event do switch on headlight for sometime after car is washed.
- ✍ Initial inclination details of head lamp lo-beam is -1% and load is 55 watts & corresponding HLLD switch positions.

12.2 TURN LIGHTS / 12.3 INTERNAL LIGHT / 12.4 BRAKES / 12.5 TYRES

12.2 TURN LIGHTS

Front & side Turn Signal Lights

1. Open front hood and fix the stay rod to mounting groove.
2. Rotate bulb holder for front indicator & side indicator, pull bulb holder along with rubber grommet from its seat in head light assembly.
3. Rotate bulb anticlockwise from its holder and remove it.
4. Replace bulb with a new one.
5. Install in reverse order of removal.

Rear Turn Signal and Reverse Indicator Lights

1. Open rear hatch.
2. Remove 2 fixing screws on 'Rear lamp assembly' and pull it from mounted slot.
3. Rotate bulb holder anticlockwise to remove from assembly.
4. Hold bulb, rotate anticlockwise and remove it from holder.
5. Replace bulb with a new one.
6. Install in reverse order of removal.

12.3 INTERIOR LIGHT

1. Use small Phillip screw driver and Pull down at groove on front part of lens to remove lens cover.
2. To remove bulb, pull it out gently.
3. While replacing bulb, make sure that contact springs are holding bulb properly.
4. To install cover, hook its rear end in and push it up till it locks with click noise.

12.4 BRAKES

Check brake fluid level in reservoir located under hood once in 2 weeks. Fluid level should be between "MIN" and "MAX" marks on side of reservoir. If level is below "MIN" mark, your brake fluid needs topping up. To fill reservoir, press cap and turn it anticlockwise to open, fill reservoir with DOT-3 brake fluid up to "MAX" level and close cap.

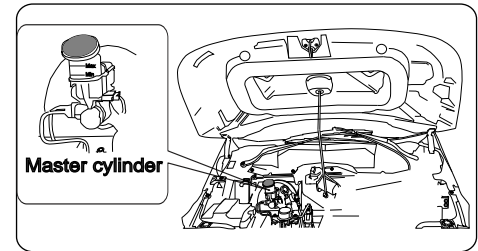

If frequent drop in fluid level is noticed, have car brake system inspected for any leaks or worn brake pads.

12.5 TYRES

For safe driving, tyres must be in good condition with adequate tread and correctly inflated.

Inflation:

Keeping tyres properly inflated provides best combination of handling, tread life and riding comfort. Under inflated tyres, wear unevenly, adversely affect handling & are more likely to fail due to overheating. Over inflated tyres can make your ride bumpy /harder. They are more prone to damage from road hazards and wear unevenly.

12.6 WINDSHIELD WASHER / 12.7 WIPER BLADES

We recommend that you visually check your tyres every week and maintain correct tyre pressure as recommended in Section on TYRES.

In addition to proper inflation, get wheel alignment done at intervals that helps to decrease tyre wear. If you observe tyre is getting worn unevenly, contact Authorised Service Centre for wheel alignment.

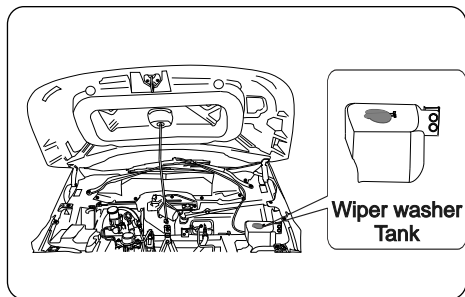

12.6 WINDSCREEN WASHER

Windscreen Washer fluid tank is located under hood on left-hand side corner. Check washer fluid in tank at least once a month. Top up fluid when necessary. Absence of washer fluid can damage your washer motor. It is advisable to always keep washer fluid topped-up.

⚠ WARNING

Use "anti-freeze" solution in windscreen washer reservoir. This will help liquid in Washer unit not be frozen during very low temperatures.

⚠ CAUTION

Damage may result if washer motor is operated whilst fluid is frozen or with no fluid in washer reservoir, or in case nozzle is blocked.

12.7 WIPER BLADE REPLACEMENT

Contamination by dust on either windscreen or wiper blade with foreign matter can reduce effectiveness of windscreen wiper. If blades are not wiping properly, its could be time to replace them. To replace wiper blade, press retaining clip and pull the blade off arm. Push new wiper blade into arm and hear clicking noise for positive locking of new blade.

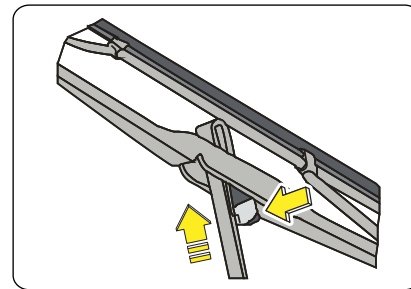

12.8 MAINTENANCE SCHEDULE

Service at the interval listed x 10,000 kms or number of months, whichever is earlier	x 10000 kms	1	2	3	4	5	6	7	8	9	10
	Months	12	24	36	48	60	72	84	96	108	120
SUSPENSION											
Front suspension bolts torque				I			I			I	
Rear suspension bolts torque				I			I			I	
A-arm bush				I			I			I	
A-arm ball joints (play/loose)				I			I			I	
Anti roll bar bush				I			I			I	
Anti roll bar ball joints (play/loose)				I			I			I	
Trailing arm bushes				I			I			I	
Pan hard rod bushes				I			I			I	
DOORS											
Both doors opening / closing & door mounting bolts tightness				I			I			I	
STEERING											
Steering wheel play / loose				I			I			I	
Tie-rod end ball joints (play / loose)				I			I			I	
BRAKES											
Brake fluid level & change	I	I	R	I	I	R	I	I	R	I	I
Brake pipes & hoses			I			I			I		
Parking brake	I	I	I								
Front brake pads / caliper			I			I			I	R	
Rear brake shoes			I			I			I	R	

Maintenance Schedule

R = Replace, I = Inspect & Correct, D= Download, C = Clean NOTE: Inspect or Clean can lead to REPLACE, based on condition of part.

NOTE

Scheduled services - first at 10000kms (or 12month)* & second at 20000kms (or 24 months)* and third at 30000 kms (or 36 months)* are mandatory. Failure in getting them performed on vehicle results in car warranty getting null & void. ***Which ever is earlier**

12.8 MAINTENANCE SCHEDULE

Service at the interval listed x 10,000 kms or number of months, whichever is earlier	x 10000 kms	1	2	3	4	5	6	7	8	9	10
	months	12	24	36	48	60	72	84	96	108	120
TRANSMISSION											
Transmission oil				R			R			R	
HVAC											
Air filter (fresh air inlet)		C	C	C	C	C	C	C	C	C	
ELECTRICAL											
All lights, Horns, Wipers & washers		I	I	I	I	I	I	I	I	I	
Key fob function		I	I	I	I	I	I	I	I	I	
Head light aiming switch function		I	I	I	I	I	I	I	I	I	
Door mirror adjustment switch function		I	I	I	I	I	I	I	I	I	
Power windows- Up / Down		I	I	I	I	I	I	I	I	I	
Gear lever function (All modes)		I	I	I	I	I	I	I	I	I	
Brake pot settings		I	I	I	I	I	I	I	I	I	
Accelerator pot settings		I	I	I	I	I	I	I	I	I	
Tub Electronics- hardware tightness / Torque				I			I			I	
Power Pack Capacity (Remotely)		I	I	I			I			I	
Auxiliary battery 12V							R				
FINAL INSPECTION											
Tyre pressure		I	I	I	I	I	I	I	I	I	
Tyre rotation				Y			Y			Y	
Wheel alignment				I			I			I	
Wheel nuts torque		I	I	I	I	I	I	I	I	I	
Under body nuts & bolts tightness				I			I			I	
Road test				I			I			I	
Service reminder indicator & message (reset)		I	I	I	I	I	I	I	I	I	

R= Replace, I = Inspect & Correct, D= Download,C=Clean, Y= Yes **NOTE:**Inspect or Clean can lead to Replace, based on condition of part.

12.9 FUSE BOX

12.9 FUSE BOX

Components in car are protected from short circuits by fuses. Fuse box containing various fuses with their ratings for different operations is located below hood. It also has relays for other functions.

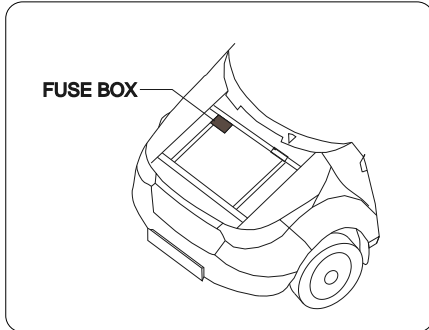

If any of car functions are not working satisfactorily or has stopped working, it could be due to a blown fuse or short circuit. Replace fuse & get short circuit rectified at authorised service center.

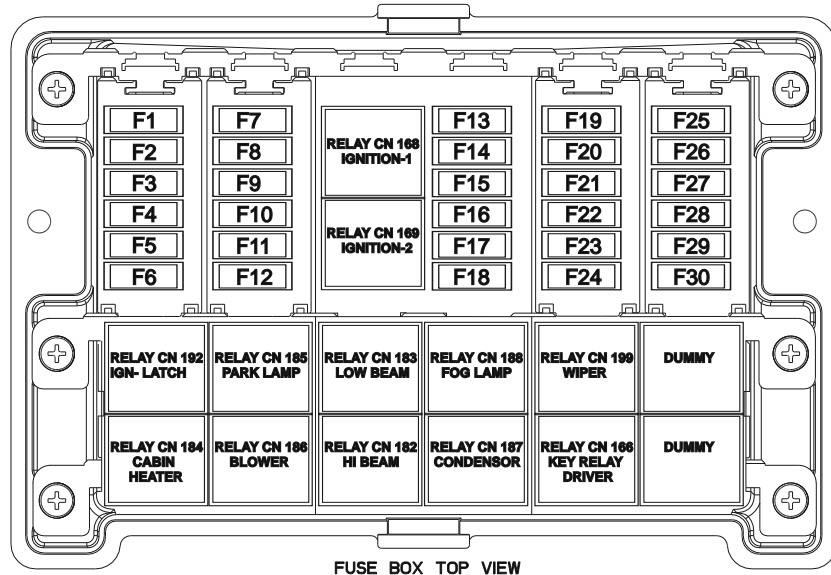

⚠ CAUTION

Always use fuses of correct rating. Do not use wire or aluminum for a fused circuit. Remember to replenish fuse box with spare fuses that can be purchased from Authorised Service Centre.

12.9 FUSE BOX

FUSE NO	RATING (A)	CIRCUIT PROTECTED
F1	15	Head lamp low beam LH & RH
F2	3A	Relay H/L low & high beam, position lamp
F3	3A	Brake lamp & high mount stop lamp
F4	7.5A	Horn
F5	15A	LH & RH door lock, Rear hatch-release
F6	15A	Front wiper
F7	15A	Head lamp high beam LH & RH
F8	5A	Position, roof, License lamps & back illumination
F9	3A	Remote relay blower, remote & heater relay
F10	-----	Empty
F11	10A	Remote & Condenser fan, BLDC controller fan
F12	15A	Blower & speed regulator module
F13	30A	Power window motor LH & RH
F14	20A	Electric vacuum pump (EVP)
F15	15A	Rear hatch defroster
F16	7.5A	Front fog lamp
F17	3A	Relay -key ON/OFF (Ignition)
F18	3A	OVRM, H/L adjuster LH & RH, switch
F19	15A	Side indicators & Hazard
F20	7.5A	Infotainment system
F21	3A	HVAC control module & IP cluster
F22,F23 & F24	---	Empty
F25	3A	Ignition I/P to BCM & IEMS
F26	7.5A	Aux 12V socket
F27	3A	Ignition I/P to KSI SSR
F28	3A	Wiper & washer
F29	3A	IGN I/P to HVAC, infotainment & OBD
F30	10A	Switch supply to PRNDL, reverse lamp, camera & Motor fan

RELAY NO	RELAY NAME
CN166	Key relay driver
CN168	Key relay 1
CN169	Key relay 2
CN182	Head light low beam
CN183	Head light High beam
CN184	Air condition-Heater
CN185	Park lamp
CN186	Blower remote operation
CN187	Condenser Fan
CN188	Front fog lamp
CN192	Key switch
CN199	Wiper

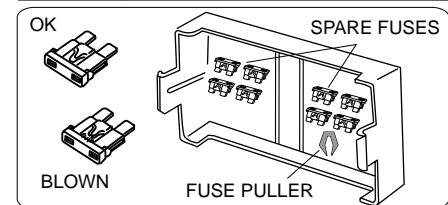

FUSE REPLACEMENT:

Open fuse box, identify amperage and location by referring fuse list on fuse cover. Check fuse, if blown use fuse puller to replace with spare fuse provided inside of fuse box cover after rectification of problem. Replenish fuse & refit fuse box cover.

12.10 INTERIOR / 12.11 STORING OF CAR

12.10 INTERIOR

i. Carpets

To remove dirt, vacuum carpets frequently. Always keep the carpets as dry as possible.

ii. Fabric

Vacuum dirt or dust out of upholstery fabric frequently. To clean stubborn stains, use a commercially available fabric cleaner. To make sure it does not bleach or stain the fabric, test it on a hidden area of the fabric. Make sure solution does not penetrate into foam beneath the fabric. Covering seat headrest with a cover will ensure that upholstery is maintained.

iii. Windows & glass

Clean inside & outside window surface with soap, water or a commercially available glass cleaner. This will remove haze that builds up on inside of windows. Use a soft cloth or paper towels to clean all glasses and clean interior plastic surfaces.

iv. Seat Belts

If vehicle seat belts get dirty, do use a soft brush with a mixture of mild soap &

warm water to clean them. Do not use bleach, dye, or solvents as they can weaken belt material. Let the belts air-dry before vehicle use.

Dirt builds up in loops of seat belt anchors and can cause belts to retract slowly. Wipe insides of loops with a clean cloth dampened in mild soap and warm water.

⚠ CAUTION

- ✍ Do not use or spray water in interior of car. Doing so can result in damage(s) to various electronics components. It is advised to vacuum clean inside when required.
- ✍ Do not use strong house hold soap & chemical for cleaning.
- ✍ Avoid washing under direct sun light, doing so, surface may become water spotted.



12.11 STORING YOUR CAR

In event of not using your car for an extended period for e.g. a week or so:

- Ensure it is kept on charge while you are away. The computer-controlled on-board charger will keep Power Pack charged as and when a discharge takes place when plugged in with mains ON.
- If vehicle is to be stored for longer period, enable 'Vacation mode', plug in car and it should ideally be supported on jack stands / blocks, so that tyres are off the ground.
- Support wiper blade arms with a folded towel or paper tag so that they do not touch windshield.

NOTE:

Carefull while purchasing the 'air freshners' as some of them can damage your vehicle interiors.

APPEARANCE CARE

Regular cleaning and polishing of car helps in keep it looking new. Here are some tips on preserving its appearance.

12.12 EXTERIOR / 12.13 END OF LIFE - DISPOSAL

12.12 EXTERIOR

i. Washing:

- Dirt or grit can scratch body panel, while tree sap & bird droppings can ruin the finish permanently.
- Use antistatic brush provided in car for cleaning car roof panel.
- Rinse vehicle thoroughly with cold water to remove loose dirt.
- Mix mild detergent specially made for car, wash with cold water.
- Wash car using sponge or soft cloth. Start from top to bottom & rinse frequently.
- Check car body for tree sap and other foreign particles. Clean it soon as possible to prevent any stain marks on panel and harms finish.
- After washing, dry it with chamois or a soft towel.
- Use glass cleaner to clean vehicle glass.

ii. Wheels and wheel covers:

- Remove wheel covers carefully, wash & keep on a soft surface so they do not get scratched.
- Use a mild detergent and soft brush to clean wheels.
- Wash wheels & wheel caps with water.

CAUTION

- ✍ Do not use glass or plastic cleaner on gauges / meter display lense covers that may damage them & reduce visibility.
- ✍ Never use benzene, thinner to clean any part of vehicle.

CAUTION

Vehicle owners should contact local distributor, MREVPL for disposal of used vehicle parts / materials after it's end of life.

Local distributor, MREVPL would guide to engage necessary local accredited agencies for disposal by abiding to local laws & pollution control board regulations.

12.13 END OF LIFE - DISPOSAL

As this is an electric vehicle, and many electric & electronic parts are used in its system. Part composition is given in next column that can be recycled and after the end of life of car & it has to be disposed without causing pollution to environment.

COMPOSITION

Vehicle is made from steel, ABS panels, Aluminum, Lead, Copper, wood, other plastics, glass, rubber & misc. These are reusable by recycling & also some are hazardous to environment and living beings hence to be disposed as per local pollution board regulations.

DISPOSAL:

- As batteries are made of lithium & iron phosphate with solvents as electrolyte which are harmful, make impact on environment are to be disposed as per local pollution board regulations.
- Similarly ABS & other plastic panels, materials used are to be disposed to accredited agencies for recycling.
- Most of other materials are reusable, hence components are to be segregated as per their composition as hazardous and non hazardous, disposed to accredited recycling agencies.

Hence it is advised to contact authorized service center or MREVPL for parts or vehicle disposal.

13.1 Emergency safety.....	99
13.2 Battery.....	99
13.3 Recovery and Towing of Car.....	100
13.4 Emergency exit.....	101
13.5 Safety features.....	101

13 EMERGENCY AND USER INFO

13.1 EMERGENCY SAFETY / 13.2 BATTERY

13.1 EMERGENCY SAFETY:

48V SAFETY MEASURES

The below safety measures are set with 48V system.

1. 48V positive(+) and negative(-) are insulated from vehicle chassis.
2. 48V components are labelled and harnesses are orange colour coded for easy identification to isolate / help, protect occupants & emergency responders from any electric shock.

IDENTIFYING 48V SYSTEM IS ON:

1. If key switch LED is illuminated green then 48V system is active.
2. If charge indicator on cluster is blinking then 48V system and also 230V AC supply is active.
3. If HVAC is operating then 48V system is active.

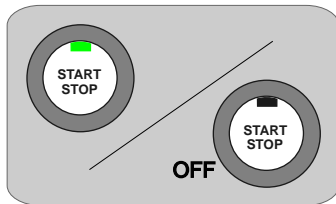

TURNING OFF POWER SWITCH

Press key switch once to turn off the system. This is indicated by status LED turning off.

CAUTION

In event of road accident:

- ✎ Check if vehicle is drivable, if so drive off to road side, apply parking brake & turn off key switch.
- ✎ Do a visual check for any damage to bottom side of vehicle & inform dealer service for support.
- ✎ In event of fire, appraise first responder that this is an EV & should use AB type extinguisher for dozing fire.
- ✎ In event of rear collision, check extent of damage to on board regular / fast charging ports, contact dealer service person for assistance.
- ✎ For accident body repair contact service dealer.

13.2 BATTERY

Vehicle battery is of Li-ion type and has some solvents as electrolyte. Any event of fire or high impact accident damaging battery, user is advised to walk away from the vehicle and notify appropriate responder and appraise fact that vehicle is an EV with 48V DC system. Battery electrolyte is colour less and has sweet odor, in event of coming in contact may irritate skin & eyes. Use excess water to rinse area of contact and see a doctor immediately. This is highly flammable and for small fire, ABC type fire extinguisher to be used for dozing it. Since battery modules are sealed and small in size, electrolyte will not leak in large quantity.

JUMP STARTING



Vehicle system has an auxiliary battery and should not be used to 'jump start' any of battery in the system. Also do not use car to jump start any other vehicles.

13.3 RECOVERY & TOWING OF CAR

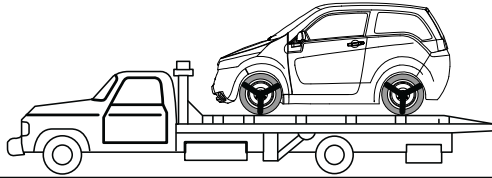

1. Flat bed Towing

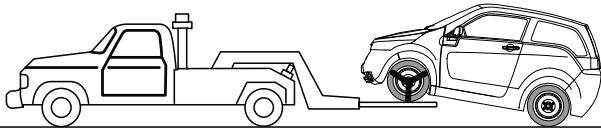

2. Wheel lift type - From front

RECOMMENDED RECOVERY PROCEDURE

In emergency towing requirement for your vehicle it is advised to follow above 2 types and 3rd type has to be adopted in the event of non availability of 'Recovery vehicle'. Normally break down vehicle can be recovered by 3 types as below that are safe.

1. Flat bed : Break down vehicle is loaded on to back of recovery truck.
This is safest & best way of towing.

Note: Ensure that 'Key Switch' is off while recovering car by 2nd method & towing of car.

2. Wheel lift: Tow truck pivot arms go below tyres of front and lift them off ground. While other two wheels are on ground.
3. Towing by cable: Break down vehicle is fixed with a tow hook and using a towing cable, it is towed by another vehicle.

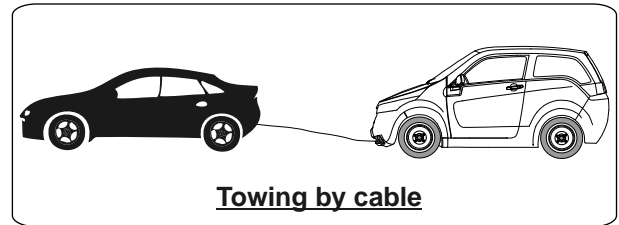
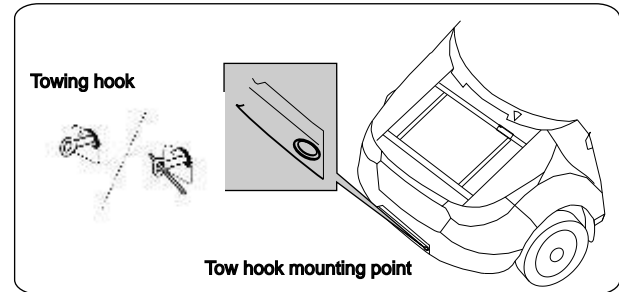

13.4 EMERGENCY EXIT / 13.5 SAFETY FEATURES

3. Towing by cable

For a breakdown, push the car towards one side of road. Take tow hook available in tool kit. Tow hook mounting threaded holes are provided at front LH side ends of chassis cross member near bottom grill below number plate. Fix hook by turning it in the hole in anticlockwise. Tie one end of towing rope to tow hook eye of break down vehicle and other to vehicle towing it. While towing, key should be in off position, hand brake released and towing speed limited to less than 20Kmph . This requires another person for steering & handling break down vehicle.

CAUTION

- ✍ Always switch on hazard warning of both vehicles to caution other users of road while towing breakdown vehicle.
- ✍ Do not tow break down vehicle at more than 20 kmph speed.
- ✍ Always maintain a gap of 4 meters between breakdown & towing vehicle.
- ✍ Always tow vehicle without jerks to avoid snapping of towing eyelet.

13.4 EMERGENCY EXIT

To come out of car in emergency due to of central door lock failure, use rear hatch glass release on tail light trim panel by removing grommet and pulling cable .



13.5 SAFETY FEATURES

Your car has many features that are unique, very safe and reliable.

Steel Space Frame Chassis and Side Impact Beams:

A specially developed steel frame chassis with side impact beams cocoons passengers in an inadvertent accident.

Special Crush Zone:

Frontal crush zone housing spare wheel, reduces effect of impact in an event of head-on collision.

Dent Proof Body Panels:

Most accidents in cities involve low speed skirmishes often leaving owners with expensive tinkering jobs. Our car's body panels are made of ABS which is a special plastic.

Energy Absorbing Bumpers:

Energy absorbing bumpers in car, can withstand low magnitude impact & reduce external damage.

Additional Safety Features:

- i. Car does not move unless charge cable is unplugged from charge port.
- ii. In case you have forgotten to engage parking brake after turning off key switch & door is opened, warning chime gets activated.
- iii. Depending on level of charge, your car is designed to automatically switch to "Economy mode" or "power save mode" to reach near by location.
- iv. Tyres used in car are tubeless, designed for all weather conditions. They provide best driving range with improved road grip.

14.1	Vehicle identification number.....	103
14.2	General	104
14.3	Performance	104
14.4	Motor	104
14.5	Motor controller.....	104
14.6	Controls.....	104
14.7	Battery pack.....	105
14.8	Suspension type.....	105
14.9	Tyres.....	105
14.10	Electricals	105
14.11	Braking System	106
14.12	Body Panels & Bumpers	106

14

TECHNICAL SPECIFICATIONS

14.1 VEHICLE IDENTIFICATION NUMBERS

LOCATION OF VEHICLE IDENTIFICATION NUMBERPLATE

Vehicle identification plate is riveted on chassis strut cross member and it is a 17 digit alpha numeric number.

LOCATION OF VIN punch & Chassis number

VIN is also punched on right hand side of chassis strut member & last 4 digits gives the chassis number.

LOCATION OF MOTOR NUMBER

Motor number is punched on body of motor.

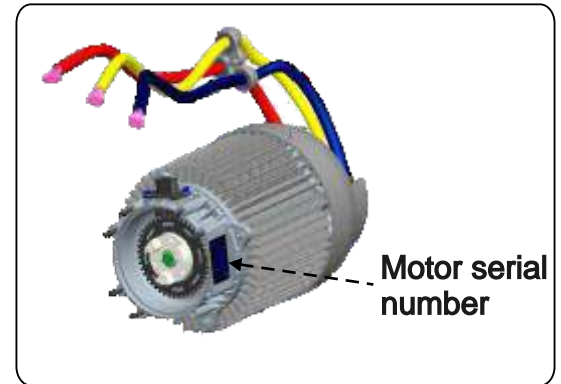
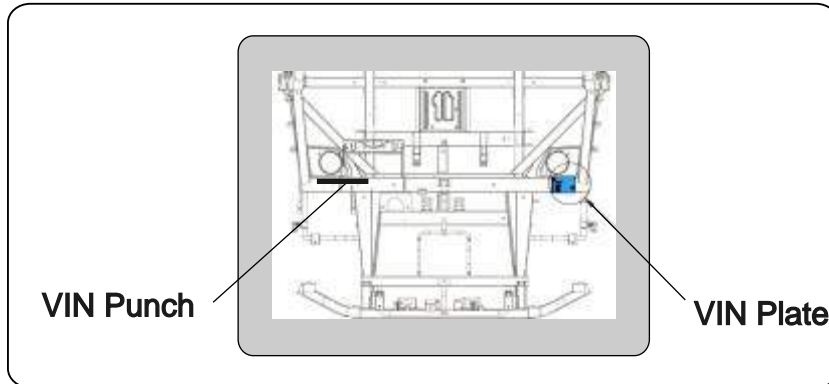

14.0 TECHNICAL SPECIFICATIONS

14.2 GENERAL	
Type	2 Door hatch-back Right Hand Drive
Seating Capacity	4 Adults(D+3)
Overall Length	3280 mm
Overall Width	1514 mm
Overall Height	1560 mm
Wheelbase	1958 mm
Ground Clearance	180 mm
Kerb Weight	830 Kgs.
Gross Vehicle Weight Rating	1130 Kgs.
Turning Radius	3900 mm
Steering Gear Box	Rack & Pinion
Frame Type	Welded Tubular Steel Space Frame

NOTE

A 20% drop will be noticed in driving range if A/C or Heater & Wiper is in use during drive.

14.3 PERFORMANCE	
Estimated range	100 kms* in F mode under normal driving conditions
Estimated top speed	81 kmph [Electronically Limited]
Maximum gradeability	9.9° / 17%
Estimated charge time	100% SOC in 5hours

* In F mode without using any accessories

14.4 MOTOR	
THREE PHASE SQUIRREL CAGE INDUCTION MOTOR	
POWER	25.5 HP (19KW)@3750 RPM
TORQUE	53 N-m @3500 RPM (±5%)

14.5 MOTOR CONTROLLER	
Type	3 phase AC Motor Controller with hill hold & restraint

14.6 CONTROLS	
2 pedal operation (Brake and Accelerator) 4 operating modes (R,N,F,B)	
The RNFB mode selection lever provides Reverse / Neutral / Forward / Boost power modes of operation.	

14.0 TECHNICAL SPECIFICATIONS

14.7 POWER PACK / AUX. BATTERY

Battery type/ location	Lithium Ion battery / packaged under the front seats.
Pack voltage	48V DC system
Capacity	200 AH
Aux. Battery	12V, 7Ah

14.8 SUSPENSION TYPE

Front	MacPherson strut - Gas filled
Rear	Trailing arm with pan-hard rod supported by gas filled shock absorber with coil springs.

NOTE: Initial inclination details of heal lamp Lo-beam is -1% and load is 55 watts & corresponding HLLD switch positions.

14.9 TYRES

Tyre size (Front & Rear)	155 / 70 R 13, Tubeless
Tyre pressure (Laden)	Front & Rear: 32psi

NOTE: The tyres fitted in the vehicle meet the requirements of BIS and they would comply with the requirements under the CMVR 1989, as mentioned Notification SO 2953E

14.10 ELECTRICALS

car uses 12V D.C. for its lighting system.	
Headlights- HI / LOW	55Watts-Halogen bulbs
Parking (front& rear)	5Watts
Front hood lamp	2Watts
Indicators (Front & Rear)	21Watts
Side indicators	5Watts
Brake light (stop)- LED	3Watts
Roof light	10Watts
Reverse light	16Watts
License plate light	5Watts
Charge port lamp	2Watts

14.0 TECHNICAL SPECIFICATIONS

14.11 BRAKING SYSTEM

Type	Hydraulic
Front: Disc	215 mm
Rear: Drum	180mm
Parking brake mechanically actuated on rear wheels.	
Hydraulic brakes with vacuum booster assisted by electric regenerative braking to optimize driving range.	
Asbestos free brake liners.	

14.12 BODY PANELS & BUMPERS

Body Panels	Dent resistant high Impact ABS .
Bumpers	Dent resistant high Impact ABS . (Energy absorbing plastic bumpers)

NOTE

In favour of product development, specifications are subject to change at any time without notice.

15 INDEX

A		D		G	
Anti theft light.....	41	Door open light.....	41	Gear lever and drive modes.....	44
Accessories.....	46	DTE - indicator.....	43	Glove box.....	45
Air flow vents.....	50	Door locks.....	66	General checks.....	69
Air flow modes.....	50	Driving.....	72	H	
Air recirculation mode.....	51	Drive -troubleshooting.....	74	Hood.....	12
B		Do's and Don'ts.....	85	Hatch-rear.....	13
Beverage holder.....	14	E		Head rest.....	34
Bottle holder.....	45	Electric vehicle system.....	17	Headlights.....	38
Blower.....	50	EV warning light.....	40	Heater.....	52
Blower Demister.....	51	Efficiency indicator.....	42	Hazard warning.....	66
Brakes.....	90	Eco setting.....	58	Horn.....	67
Battery.....	99	Extending your drive range.....	73	Head light focus switch.....	67
C		Exterior.....	97	Hill Hold.....	73
Charge Cable Compartment.....	13	End of life- disposal.....	97	I	
Charge Duration.....	24	Emergency safety.....	99	Ideal time to charge.....	24
Charging- high voltage lines.....	27	Emergency exit.....	101	Instrument cluster.....	37
Charging- troubleshooting.....	28	F		Infotainment system.....	47
Charge point requirements.....	29	Fast charging.....	25	Interior.....	96
Charge light.....	39	Fuse Box.....	94	K	
Climate controls.....	49	Fuses, replacement.....	95	Key fobs and Keys.....	65
Cooling.....	51			Key fob operation.....	65
Chime.....	65				
Changing flat tyre.....	81				

INDEX

L

Low brake fluid light.....	39
Lights-replacement of bulbs.....	89

M

Mode and set button.....	42
My car info.....	55
Mobile App.....	58
Mirrors.....	67
Maintenance Schedule.....	92

N

Normal charging.....	22
----------------------	-----------

O

Odometer.....	41
OVRM adjuster	67

P

Parking brake.....	14
Parking brake Light.....	39

R

Rear hatch glass.....	13
Rear seat access.....	33
Rear defogger.....	52
Roof light.....	68
REVive.....	73

S

Seat adjustment.....	32
Seat belts.....	33
Service light.....	40
Seat belt light.....	41
Speedo meter.....	41
SOC and bar gauge.....	42
Sun visor.....	68
Starting.....	71
Spare wheel.....	81
Storing of car.....	96
Safety features.....	101

T

Trickle charging.....	26
Turn signals.....	39
Temperature light.....	40
Trip meter.....	41
TTC - indicator.....	43
Tyres.....	79
Tyre pressure.....	79
Tyre marking.....	79
Tyre rotation.....	80
Tyre inspection.....	81
Towing of the car.....	100
Technical specifications.....	104

V

Voltage lines.....	15
Vehicle charging.....	21
Vacation mode.....	62
Vehicle identification number.....	103

W

Wind screen wiper.....	43
Wiper washer nozzle.....	43
Wiper washer tank.....	69
Wheel alignment and balancing.....	80
Wiper blade replacement.....	91

Mahindra **REVA**



COMPLETE CUSTOMER CARE

Mahindra Reva Electric Vehicles Pvt. Ltd.,

#484, Lakshmi Arcade, 1st Floor, 27th Main, 17th Cross, HSR Layout,

Sector II, Bangalore- 560102, Karnataka, India. Phone: +91 80 42486200,

E-mail: CUSTOMERCARE@mahindrareva.com ; CUSTOMERCARE@mahindra.com

Web: www.mahindrareva.in

Keep this book in the vehicle at all times contains important information on safety, operation and maintenance.