

# Owner's Manual



---

**ISSUE DATE: May 2015**

**NOTE:** *Carefully read, understand and follow the instructions provided in this manual, and keep it in a safe place for future reference. If you have any doubt whatsoever regarding the use or care of your vehicle, please visit your Mahindra dealer for assistance or advice.*

*This Owner's Manual should be considered as an integral part of the vehicle and should remain with the vehicle.*

**Mahindra**

---

MAHINDRA & MAHINDRA LTD., GATEWAY BUILDING, APOLLO BUNDER, MUMBAI - 400 039

*[www.mahindra.com](http://www.mahindra.com)*



# Table of Contents

1	INTRODUCTION AND SAFETY PRECAUTIONS .....	1-1	Tailgate .....	6-2
	Safety Symbols.....	1-1	7 FEATURES AND CONTROL.....	7-1
	General Safety Information and Instructions.....	1-2	Manual Windows .....	7-1
	To Owner's of a Mahindra Vehicle .....	1-3	Outside Rear View Mirror (ORVM) .....	7-1
2	GENERAL .....	2-1	Interior Mirror (if equipped).....	7-1
	Lubricants and Capacities .....	2-1	Lamps.....	7-2
	Dimensions.....	2-2	Utility.....	7-6
	Fuses and Relays .....	2-3	Horn .....	7-7
	Bulb Specification .....	2-6	Windshield Wiper/Wash (if equipped).....	7-8
	Flat Tire.....	2-6	Instrument Cluster .....	7-8
	Technical Specifications .....	2-10	Warning Lamps in the Instrument Cluster.....	7-11
	Vehicle Identification Number (VIN) .....	2-12	Radio Frequency ID (RFID) Tag.....	7-14
3	VEHICLE OVERVIEW .....	3-1	8 STEERING AND BRAKES.....	8-1
	Front Overview .....	3-1	Steering .....	8-1
	Side Overview.....	3-1	Braking .....	8-1
4	INSTRUMENT CLUSTER AND WARNING LAMPS OVERVIEW.....	4-1	9 AIR-CONDITIONING SYSTEM (AC) .....	9-1
	Instrument Cluster .....	4-1	Overview.....	9-1
	Warning Lamps .....	4-1	Vents .....	9-2
5	SEATS AND SEAT BELTS .....	5-1	AC ON/OFF.....	9-2
	Driver Seat.....	5-1	Blower Speed Control.....	9-3
	Head Restraint .....	5-1	Cooling Control .....	9-3
	General Warnings and Instructions- Seat Belts .....	5-1	Windshield De-mist .....	9-3
	Fastening/Unfastening the Seat Belt.....	5-3	Heater .....	9-4
6	LOCKS AND KEYS .....	6-1	10 STARTING AND DRIVING THE VEHICLE .....	10-1
	Front Doors.....	6-1	Safety Tips - Before Starting your Vehicle.....	10-1

# Table of Contents

Ignition Switch.....	10-1	Maintenance - Inside the Vehicle.....	13-14
Starting the Engine.....	10-2	Maintenance-Outside the Vehicle.....	13-14
Gear Shifting.....	10-3	Battery.....	13-15
Driving Your Vehicle.....	10-4	Appearance Care and Protection.....	13-16
Stopping the Engine.....	10-6	Air Conditioning System Maintenance.....	13-19
4WD System (if equipped).....	10-6	Vehicle Storage.....	13-19
Fuel.....	10-9	Winter Care.....	13-19
11 WHEELS AND TIRES.....	11-1	Maintenance Service Information.....	13-20
Tire Pressure.....	11-1		
Tire Pressure.....	11-3		
Tire Rotation Recommendations.....	11-5		
12 EMERGENCIES.....	12-1		
Hazard Warning Lamp.....	12-1		
Vehicle Does not Start - Checks.....	12-1		
Vehicle Overheating.....	12-2		
Jump Starting.....	12-3		
Limp Home Mode.....	12-5		
Towing.....	12-6		
13 MAINTENANCE.....	13-1		
General Owners Information.....	13-1		
Opening/Closing the Hood.....	13-3		
Identifying Components in the Engine Compartment.....	13-5		
General Maintenance.....	13-6		
In the Engine Compartment.....	13-7		
Headlamp Bulb Replacement.....	13-12		



## 1 INTRODUCTION AND SAFETY PRECAUTIONS

Dear Customer,

Congratulations on purchasing Mahindra THAR. Your vehicle has been designed to provide years of safe and dependable service, as long as it is used and maintained in accordance with the instructions provided in this manual.

All persons who will use and/or maintain this vehicle must read, understand and follow all warnings and instructions provided in this manual. This Owner's Manual should be considered an integral part of the vehicle and should remain with the vehicle. However, nothing in this manual, and none of the safety devices installed in the vehicle, are a substitute for careful operation and common sense. Always make sure that your vehicle is in optimum working order, and take note of the road and weather conditions under which you are using your vehicle.

If you have any questions concerning the proper use or maintenance of your vehicle, please call your Authorized Mahindra Dealer.

Alternatively you can contact Mahindra at,

- 1800-209-6006 (Toll free)
- [customercare@mahindra.com](mailto:customercare@mahindra.com)

We extend our best wishes for safe and pleasurable motoring.

Sincerely,

MAHINDRA & MAHINDRA LTD

### 1.1 Safety Symbols

Carefully read, understand and follow the safety symbols/ instructions given in this manual.

#### Legend of the Symbols

To emphasize information and procedures regarding safety, use, maintenance, etc., the following symbols are used throughout the manual.



*DANGER indicates an imminently hazardous situation which, if not avoided, will result in death or serious injury.*



*WARNING indicates a potentially hazardous situation which, if not avoided, could result in death or serious injury.*



*CAUTION indicates a potentially hazardous situation which, if not avoided, may result in minor or moderate injury and/or property damage.*



*NOTICE indicates important information relevant to the vehicle, the vehicle's use or to sections of this manual to which particular attention must be paid for optimum use of the vehicle.*

If you see this symbol, it indicates "no", "do not," "do not do this," or "never".



## 1.2 General Safety Information and Instructions

### WARNING

*Failure to follow the warnings and instructions provided in this manual could result in failure of the vehicle, an accident and/or serious personal injury.*

1. Carefully read, understand and follow the warnings and instructions given in this manual. This manual is an essential part of the product. Keep it in the vehicle glove box for future reference
2. Spare bulb and first aid kit are placed in the glove box of the vehicle. Ensure they are not taken out of the vehicle at any point of time.
3. Please note that throughout this manual, reference is made that “an accident” could occur. An accident could cause you or a bystander to sustain severe personal injury, or result in property damage
4. Never use a mobile phone or personal music device while driving. This may take your focus off the road and lead to accidents
5. Please be advised that many service and repair tasks require specialized knowledge, tools and experience. General mechanical aptitude may not be sufficient to properly service or repair your vehicle. If you have any doubt whatsoever regarding your ability to properly service or repair your vehicle, please contact your Authorized Mahindra Dealer or a qualified technician
6. Inspect the seat belt system periodically, checking for cuts, frays or wear in the seat belt webbing, or loose buckles, retractors, anchors or other loose parts. Damaged parts must be replaced immediately
7. Always start and operate the engine in a well-ventilated area. If in an enclosed area, vent the exhaust to the outside. Do not modify or tamper with the exhaust system
8. Examine tires for excessive tread wear and uneven wear patterns. Check for stones, nails, glass, or other objects lodged in the tread and check sidewalls for any cuts, cracks, or other signs of wear. Replace as necessary
9. Always maintain the safety labels affixed to your vehicle in a good legible condition
10. All signal lamps, buzzers, shields, guards and other protective safety devices must always remain in place and in good, proper working condition
11. The life span of Mahindra products depend on many factors. Improper use, abuse or harsh use in general may compromise the integrity of the vehicle and significantly reduce its life span. The vehicle is also subject to wear over a period of time. Please have your vehicle regularly inspected by an Authorized Mahindra Dealer or a qualified mechanic. If the inspection reveals any damage or excessive wear, immediately replace or have the component serviced
12. We recommend that you use only genuine parts supplied by Mahindra. The use of non-Mahindra parts will not be covered by warranty
13. Never crawl under or be in close proximity to the vehicle when it is lifted off the ground (by a jack), unless the vehicle is properly supported with jack stands, wheel chocks and other appropriate safety devices
14. Never attempt any repairs or adjustments to any component while the vehicle is in motion. Always switch off the engine, and wait for the engine to come to a complete stop before performing any repairs or adjustments
15. The vehicle identification plates are the only legal identification reference, hence it is necessary to keep them in good condition. Never modify data on the plates or remove them. The customer is responsible for any possible tampering with the plates, which will immediately void the warranty
16. Do not attempt sharp turns, abrupt maneuvers, or other unsafe driving actions that can cause loss of vehicle control. When the vehicle is fully loaded,



drive at a slow speed, especially when turning. Note that the center of gravity of the vehicle increases as the vehicle is fully loaded on the roof carrier

17. Disconnect NEGATIVE terminal of the vehicle battery while doing Arc welding on your vehicle. This is to avoid damage of electronic components in the vehicle.

### 1.3 To Owner's of a Mahindra Vehicle

When first driving the vehicle after long periods of non-use, you may experience a temporary drive disturbance. This is a characteristic of the tires and should be no reason for concern. The condition should correct itself within 5-15 kms. of driving. If the disturbance persists, have the tires checked by an Authorized Mahindra Dealer.

#### Driving and Alcohol

Your driving ability can be seriously impaired by alcohol even if the blood alcohol level is far below the legal minimum. Drunken driving is one of the most frequent causes of accidents.



*Never drink and drive. Drinking and driving will lead to an accident resulting in serious personal injury.*

#### Driving and Drugs/Medication

Your driving ability can be seriously impaired through the use of prescription or non-prescription drugs or medication (even cough syrup). If you are taking any sort of drug or medication, be sure that it will not affect your driving ability.

#### Mobile Phones Warning

Use of electrical devices such as mobile phones, computers, portable radios or other by the driver while driving is dangerous. If use of a mobile phone is necessary despite

this warning, use a hands free system to at least leave the hands free to drive the vehicle.

Please comply with the legal regulations concerning the use of communication equipment in vehicles in your country.

#### Driving Long Distances

When you are driving over long distances, follow these tips so that you have a safe journey;

- Lack of sleep or fatigue may impact your ability to drive safely.
- Exercise your eyes by shifting the focus of your eyes to different parts of the road.
- Use stimulating beverages such as coffee or tea.
- Relax and stay calm.

#### Protecting Our Environment

Every one of us should play our part in protecting our environment. Judicious vehicle usage and disposing hazardous waste (including cleaning and lubrication fluids) are important steps towards this initiative.

Mahindra vehicles conform to existing emission norms (standards). Adhering to the periodical maintenance schedule and using Mahindra genuine parts will help retain emission performance of the vehicle and is a pre-requisite to emissions warranty coverage.

#### Servicing

If you have any questions concerning the proper use or maintenance of your vehicle, please call your Authorized Mahindra Dealer. A list of dealers can be found in the Dealer Directory Supplement or on the Internet.

Alternatively you can contact Mahindra on **1800-209-6006** / [customercare@mahindra.com](mailto:customercare@mahindra.com).





### Running-in

Driving smoothly during first 1000 kms. will help to prevent premature failures and abnormal system wear improving the life of drivetrain and vehicle components.

A new engine may consume more oil during the first 1000 kms. of running. This should be considered as a normal part of break-in and not interpreted as any problem with the engine.

### Mahindra Genuine Parts

Mahindra uses high quality parts for building vehicles.

In the event that any parts need replacement, we recommend that you use only Mahindra genuine parts.

Non-Mahindra parts may harm vehicle performance and will not be covered by your Mahindra warranty.

To avoid counterfeit parts and to protect our brand image, Mahindra genuine parts are packed in a branded carton. Look for the "Mahindra Genuine Parts" logo.



### WARNING

*Any unauthorized modifications or alterations to this vehicle or failure to use appropriate specification and quality spare parts could seriously affect vehicle road worthiness and safety leading to an accident, resulting in serious injury*

### Mahindra Genuine Accessories

A wide selection of quality accessories is available through your authorized Mahindra dealership. These accessories have been specifically engineered to allow you to

personalize your vehicle to suit your requirements and compliment its style and aerodynamic appearance.

Each accessory is made from high quality materials and meets Mahindra's rigid engineering and safety specifications. Every Mahindra accessory installed according to the Mahindra installation provisions comes with the respective accessory warranty.

Consult your Mahindra authorized dealer for detailed information about accessories available for your specific model variant.

### Vehicle Safety

When leaving your vehicle unoccupied;

- Always remove the ignition key when you park the vehicle
- Close all the windows/ canopy completely and lock all the doors
- Do not leave any valuables in your vehicle



## 2 GENERAL

### 2.1 Lubricants and Capacities

System	Lubricant	Capacity	Specification	Remarks
Engine Oil	MAHINDRA "MAXIMILE FEO" NEW GENERATION GENUINE ENGINE OIL	6.0 liters	Special Engine Fluid	For other than Maximile brand, the oil change interval has to be reduced to 10000 km if the oil meets minimum of API CH-4 SAE 15W-40 specification
Engine Oil Filter	MAHINDRA "MAXIMILE UNIVERSE" GENUINE OIL FILTER	—		Recommend to use only the Genuine filter for better engine protection and lubricant life
Engine Cooling	MAHINDRA "MAXIMILE ULTRA COOL" (READY TO USE COOLANT. NO NEED TO MIX WATER)	8.0 liters		Brand Specific. Don't use other coolants / water for top up. In case of emergency, coolant meeting JIS K-2234 specification should be used (30% concentration diluted with distilled water) and coolant change period to be reduced as 30,000 km
Transmission	MAHINDRA "MAXIMILE SYNTEC F2" NEW GENERATION GENUINE TRANSMISSION OIL	1.75 liters	Special Transmission Fluid	If Maximile GO SYNCHRO 80W-90 is used, the oil change interval has to be reduced to 40,000 km. For other than Maximile brand, the oil change interval has to be reduced to 20000 km if the oil meets minimum of API GL-4 SAE 80W-90 specification
Transfer Case (4WD)	MAHINDRA "MAXIMILE GO 80W-90 SYNCHRO" GENUINE TRANSMISSION OIL	1.2 liters	DEXTRON IID	—
Rear Axle Oil	MAHINDRA "MAXIMILE ELITE"	1.8 liters	Special Axle Fluid	If Maximile DO EXL is used, oil change interval should be reduced to 30,000 km. For other than Maximile brand, the oil change interval has to be reduced to 20000 km if the oil meets minimum of API GL-5 SAE 80W-90 specification
Power Steering	SHELL "SPIRAX S3 ATF MD3" / CALTEX "TEXAMATIC 1888" CASTROL UNIVERSAL BRAKE FLUID	0.8 liters		Brand Specific, No other brand to be used
Brake and Clutch	"CUBF" TVS GIRLING DOT 3	0.9 liters		Brake Fluid Meeting SAE J1703; FMVSS No.116 DOT 3 or IS 8654 Type-1 Specification
Grease	MAHINDRA "MAXIMILE LCG" GENUINE WB GREASE	As Reqd.		Advise to use only the genuine grease for better life and protection. In emergencies, lithium complex grease meeting NLGI 2/3 specification can be used.
Recommended Fuel	Diesel conforming to - Indian Standard IS 1460; 2010 BSIV / BS III specification or equivalent	60 liters		—



## 2.2 Dimensions

### Front View

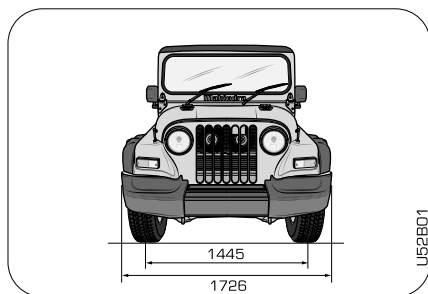

### Rear View

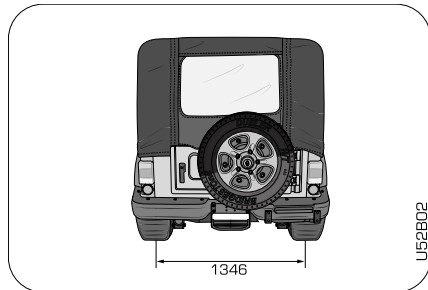

### Side View

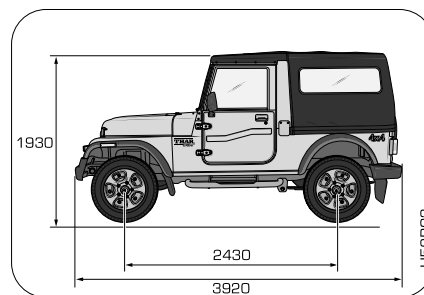



## 2.3 Fuses and Relays

### Types of Fuses

- Blade Fuse
- Mini Fuse
- Slow blow Maxi fuse

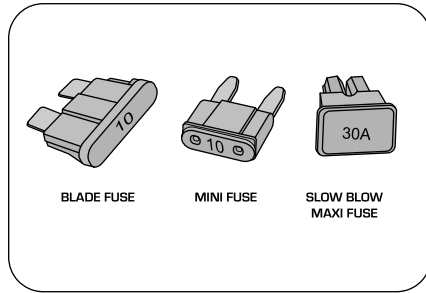

### WARNING

Switch OFF the ignition and all electrical equipment before touching or attempting change a fuse. Use a fuse puller to remove a fuse. Fit replacement fuse with the same rating as the one you have removed. Do not modify the electrical system of your vehicle, contact Mahindra authorized dealer if required.

### NOTICE

Blown fuse can be identified by a break in the filament.

## 2.3.1 Cabin Compartment Fuse Box (IP W/H)

Cabin Compartment Fuse Box (IP W/H) is located below the instrument panel on the driver side.

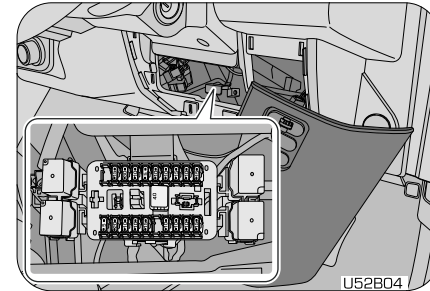

	15A	30A	10A	5A	10A	10A	15A	10A	15A
N/A	HAZARD CTRL	BLOWER FAN	AUXILIARY BATT	IMMEDIATE	AC COMP	ROOF/FRONT LAMP	HORN/HAZARD	PARK LAMP	H/L/HIGH
	FUSE PULLER		COND. FAN 40A						
5A	20A	10A	10A	15A		10A	10A	10A	15A
IMMOBILIZER	SEAT BELT	CLUSTER	FOG LAMP	HEATER	N/A	WIPER WASH/WASHER	TURN/REVERSE	AUXILIARY ACC.	H/L/LOW

U52B15



Fuse	Description
Top Row	
	N/A
15A	HAZARD CTRL
30A	BLOWER FAN
10A	AUDIO BATT
5A	IMMO/ DIAG
10A	AC COMP
10A	ROOF/ENGINE LAMP
15A	HORN/HAZARD
10A	PARK LAMP
15A	H/L HIGH
Bottom Row	
5A	IMMO/ IGN
20A	ECU K28
10A	CLUSTER
10A	FOG LAMP
15A	HEATER
	N/A
10A	WIPER WASHER
10A	TURN/REV
10A	AUDIO ACC
15A	H/L LOW
Spare Fuses	
5A	Spare Fuse
10A	Spare Fuse
15A	Spare Fuse

20A	Spare Fuse
30A	Spare Fuse

### 2.3.2 Cabin Compartment Fuse Box (Engine W/H)

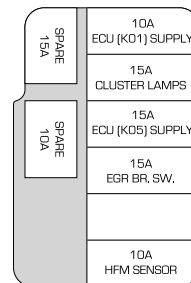

U52B16

Fuse	Description
10A	ECU (K01) SUPPLY
15A	CLUSTER LAMPS
15A	ECU (K05) SUPPLY
15A	EGR BR. SWITCH
10A	HFM SENSOR
15A	Spare Fuse
10A	Spare Fuse



### 2.3.3 Relay

Relay box is located above the accelerator pedal.

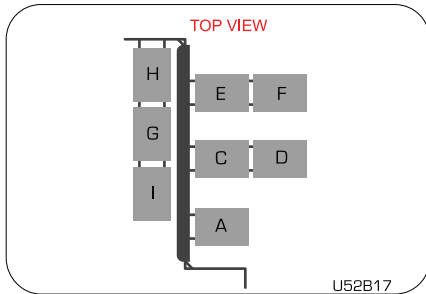
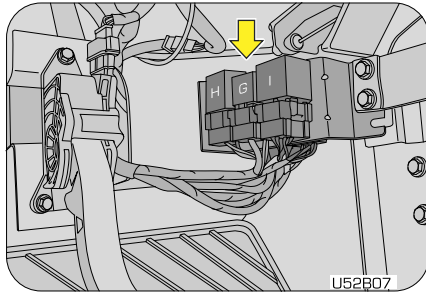

Relay	Description
A	—
B	CONDENSER FAN RLY-2
C	CONDENSER FAN RLY-1
D	BLOWER CONTROL RELAY

E	THERMO AMP RELAY
F	AC BLOWER RELAY
G	HEATER RELAY
H	DE-MISTER RELAY

### 2.3.4 Engine Compartment Fuse Box

Engine Compartment Fuse Box is located adjacent to the battery in the engine bay.

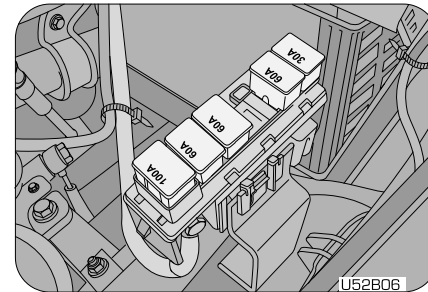
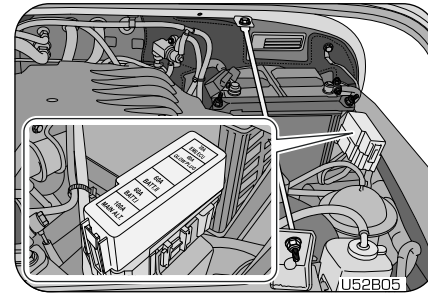



Fuse	Description
30A	EMS ECU
60A	GLOW PLUG
60A	BATT. II
60A	BATT. I
100A	MAIN ALT.

## 2.4 Bulb Specification

Bulb	Power Rating (W)	No of Bulbs
HEAD LAMP BULB	12V 60/55 W	2
FRONT TURN SIGNAL BULB	12V 21W	2
FRONT PARKING BULB	12V 5W	2
SIDE TURN INDICATOR BULB	12V 5W	2
BRAKE & PARK LAMP BULB	12V 21/5W	2
REAR TURN BULB	12V 21W	2
REVERSE LAMP BULB	12V 21W	2
REG PALTE LAMP BULB	12V 10W	2

## 2.5 Flat Tire

Reduce your speed gradually, keeping a straight line. Move cautiously off the road to a safe place well away from traffic. Park on a level spot with firm ground. Stop the engine and turn ON your hazard warning flashers.

Firmly apply the parking brake. Have everyone come out of the vehicle on the side away from traffic.

### WARNING

*Never stop your vehicle in a traffic lane to change a tire. You could be hit by an oncoming vehicle. Keep driving until you reach a safe location.*

Lifting a vehicle to change a tire or perform maintenance is very dangerous if you do not have the proper tools, safety equipment and training. The jack provided along with the vehicle is to be used only for changing a spare tire. It is never to be used to perform any other maintenance or repair on the vehicle.

### WARNING

*Never place any part of your body under any portion of the vehicle when it is supported only by the jack. You could be crushed by the vehicle if it falls off a jack. Keep everyone away from the vehicle.*

The jack and the tools are located in the box below the co-driver seat.

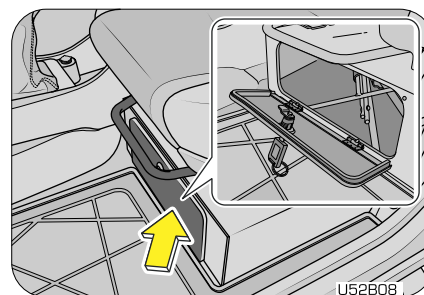

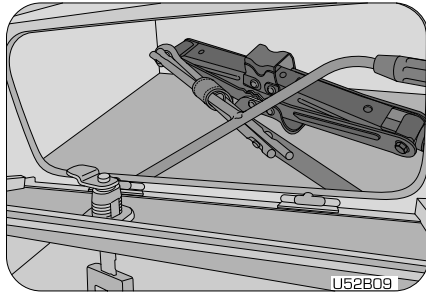

The tool kit consists of the a wheel spanner and the jack extension levers.

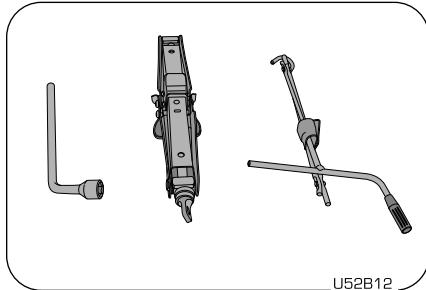

Spare wheel is mounted on a bracket on the rear tail gate of the vehicle. It is held in place by three securing nuts. A snap fit wheel cover is fitted on the spare wheel.

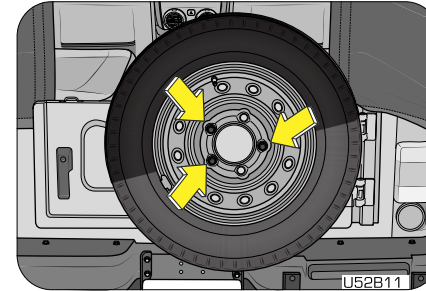
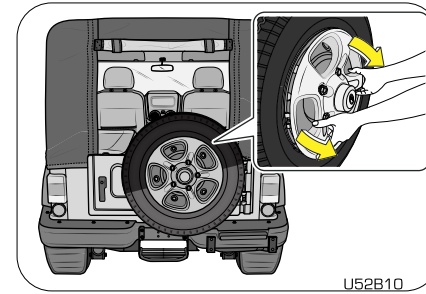

- Cautiously pry out the wheel cover using both hands as shown
- Remove the securing nuts on the spare wheel
- Remove the spare wheel

Always loosen the wheel nuts before raising the vehicle. Turn the wheel nuts counter clockwise to loosen. To get maximum leverage, fit the spanner to the nut so that the handle is on the left side. Grab the spanner near the end of the handle and push down on the handle. Be careful that the spanner does not slip off the nut. Do not remove the nuts, but loosen them by one or two turns.



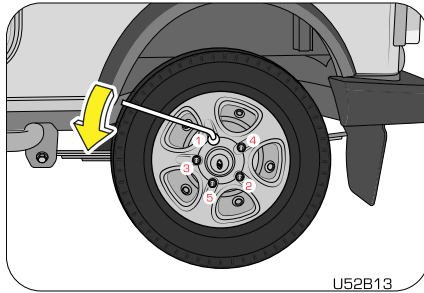

### 2.5.1 Jacking

Position the jack at the correct jacking point (under the front chassis cross member). Make sure the jack is positioned on a level and solid place. Ensure no one is in the vehicle.

Block the wheel diagonally opposite the flat tire to keep the vehicle from rolling when it is jacked up. When blocking the wheel, place a wheel block in front of one of the front wheels or behind one of the rear wheels.

Open the jack extension as shown and slide the lock to keep the handle straight. To raise the vehicle, insert the jack handle end along with the extension into the jack and turn it clockwise with the jack handle. As the jack touches the vehicle and begins to lift, check that it is properly positioned. Raise it high enough so that the spare tire can be installed. Remember you will need more ground clearance when putting on the spare tire than when removing the flat tire.

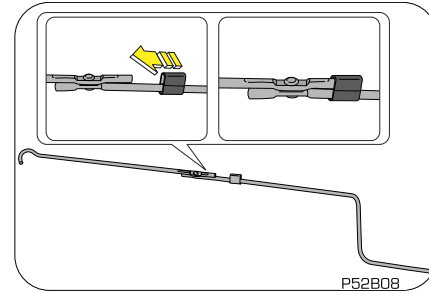
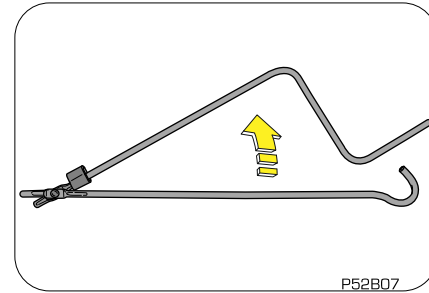

**CAUTION**  
Make sure to set the jack properly in the jacking point. Raising the vehicle with improperly positioned jack will damage the underbody of vehicle or may allow the vehicle to fall off the jack and cause personal injury.

- Use the jack only for lifting your vehicle during wheel changing
- Do not raise the jack with someone in the vehicle.



- *When raising the vehicle, do not place any objects on top of or underneath the jack.*
- *Raise the vehicle only high enough to remove and change the wheel.*
- *Follow jacking instructions*
- *Do not start or run the engine while your vehicle is supported by the jack.*

 **WARNING**

*Never get under the vehicle when the vehicle is supported by the jack alone.*

Remove the wheel nuts. Lift the flat tire straight off and place it aside. Roll the spare wheel into position and align the holes in the wheel with the bolts. Lift up the wheel and get at least the top bolt started through its hole. Wiggle the wheel and press it back over the other bolts.

Re-install the wheel nuts with the tapered end inward and tighten by hand. Press the wheel inward and tighten the wheel nuts further.

 **WARNING**

*Never use oil or grease on the bolts or nuts. Doing so may lead to over tightening the nuts, wheel nut spanner slip, damage the bolts and also may cause personal injuries. Also, nuts may loosen and the wheels may fall off, which could cause a serious accident. If there is oil or grease on any bolt or nut, clean before installing wheel nuts.*

Lower the vehicle completely and tighten the diagonally opposite wheel nuts using the wheel nut spanner. Turn the jack handle extension counter clockwise using the jack handle to lower the vehicle, making sure the handle remains firmly fitted onto the jack handle extension. Tighten each nut a little at a time in the diagonally opposite order. Repeat the process until all the nuts are tight. Do not use other tools or any additional leverage other than your hands, such as a hammer, pipe or your foot.

 **WARNING**

*Improperly or loosely tightened wheel nuts are dangerous. The wheel could wobble or come off. This could result in loss of vehicle control and cause a serious accident. Always make sure all the wheel nuts are properly/securely tightened to the specified torque.*

*When lowering the vehicle, make sure all portions of your body are clear off the vehicle as it is lowered to the ground. Have the wheel nuts tightened with the torque spanner to the required torque, as soon as possible after changing wheels.*

*If you have rotated , repaired , changed your tires or changed the wheel rims, check the wheel nuts are still tight (to the reqd. torque) after driving about 1000 Kms.*

Check the air pressure of the replaced tire. If the pressure is lower than recommended, drive slowly to the nearest service station and inflate to the correct pressure. If it is too high, adjust it until it is correct. Always reinstall the valve cap after checking or adjusting tire pressure. If the cap is not replaced, dirt and moisture could get into the valve core and cause air leakage. If you lose a valve cap, buy another and install it as soon as possible.

**Restore all the Tools, Jack and Flat Tire**

Mount the flat tire back to the bracket on the rear of the vehicle. Double check to ensure the flat tire is secure and not loose. Replace the tools (jack, wheel spanner, etc.) in their storage location.

 **NOTICE**

*It is recommended to fix the flat tire at the nearest tire shop and swap the spare wheel back. The wheel balance and alignment differ from wheel to wheel. This may lead to steering and braking issues.*



## 2.6 Technical Specifications

Technical Specifications	CRDe 2.49 L
Displacement/Cubic Capacity	2498 cc
Bore x Stroke	94 x 90 mm
Compression Ratio	17.8:1
Max. Power	79 kW (105 HP) @ 3800 rpm
Max. Torque	247 Nm @ 1800-2000 rpm
Air Cleaner	Dry Foam type
No. of Gears	5 Forward, 1 Reverse
Gear Ratio	1st – 3.78:1
	2nd – 2.09:1
	3rd – 1.38:1
	4th – 1.00:1
	5th – 0.79:1
	Reverse – 3.53
Clutch	Single plate dry type, hydraulically actuated (240 mm dia)
Drive Axle Front	Full floating hypoid type with CV joint, Ratio 4.3:1
Drive Axle Rear	Semi floating hypoid type with <b>Eaton M-Hocker</b> , Ratio 4.3:1
Steering Type	Rack and pinion, Power steering
Wheels & Tires	Wheel rim size – 6.5J X 16 (For 235/70 R16)
	Tyre Pressure – Front & Rear : 2.4 kg/cm <sup>2</sup>
Suspension	Front – IFS with Torsion Bar



Technical Specifications	CRDe 2.49 L
	Rear – Semi Elliptic Leaf Spring
	Anti-roll bar – Stabilizer Bar
	Shock Absorbers – Double acting hydraulic
<b>Brakes</b>	Dual Hydraulic Circuit with Tandem Master Cylinder, Vacuum Assisted Servo with Auto Slack Adjuster
	Front – 226 mm Disc
	Rear – 282 mm Drum
	Parking Brake – Mechanical, Operating on rear wheels
<b>Fuel Capacity</b>	60 liters
<b>Maximum GVW (kg)</b>	2510
<b>Maximum FAW (kg)</b>	950
<b>Maximum RAW (kg)</b>	1560
<b>Kerb weight with 90% fuel (with spare wheel , tools, etc.) (kg)</b>	1685
<b>Ground Clearance (mm)</b>	200
<b>Wheelbase (mm)</b>	2430
<b>Front Track (mm)</b>	1445
<b>Rear Track (mm)</b>	1346
<b>Length (mm)</b>	3920
<b>Width (mm)</b>	1726
<b>Height (mm)</b>	1930
<b>Battery</b>	12V, 72 Ah



## 2.7 Vehicle Identification Number (VIN)



Vehicle Identification Number (VIN) vehicle serial number is the legal identity of your vehicle. It is used in registering the ownership. Vehicle identification number plate is riveted on the firewall next to the battery in the engine compartment.



### 3 VEHICLE OVERVIEW

#### 3.1 Front Overview

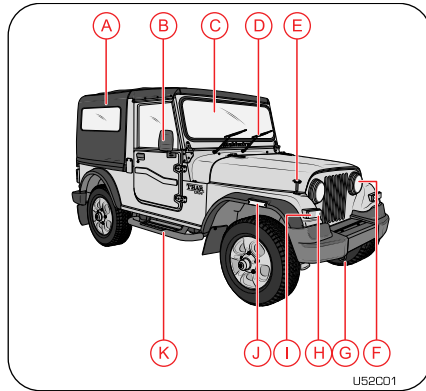

A	Canopy
B	Outside Rear View Mirror
C	Windshield
D	Windshield Wiper
E	Hood lock
F	Head lamp
G	Front Tow Hook
H	Front Parking Lamp
I	Front Right Turn Signal Lamp

J	Side Repeater Lamp
K	Side Footstep

#### 3.2 Side Overview

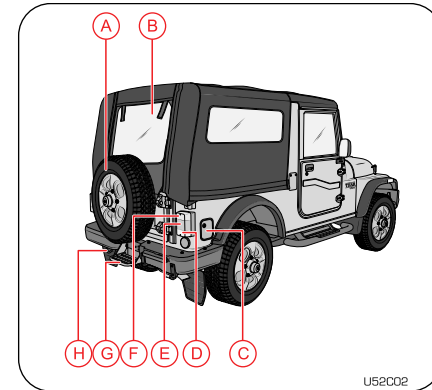

A	Spare Wheel
B	Canopy Flap
C	Fuel Filler Lid
D	Reversing Lamp
E	Rear Stop/Brake Lamp
F	Rear Right Turn Signal Lamp

## VEHICLE OVERVIEW



G	Rear Footstep
H	Rear Tow Hook



## 4 INSTRUMENT CLUSTER AND WARNING LAMPS OVERVIEW

### 4.2 Warning Lamps

#### 4.1 Instrument Cluster

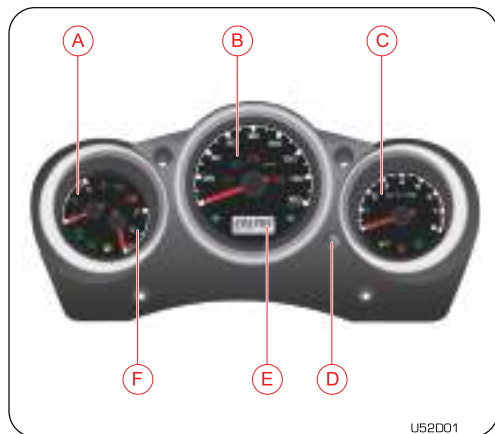



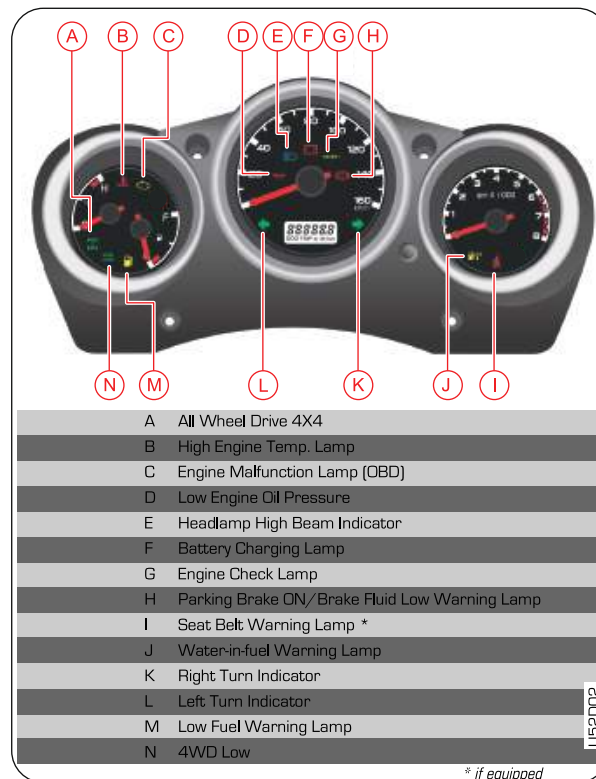



A	Temperature Gauge	D	Mode/Reset Button
B	Speedometer	E	Odometer/Tripmeter
C	Tachometer	F	Fuel Gauge













Symbol	Warning Lamp/Tell Tale	Lamp Pre-check	Lamp Status	Action/Remarks
	Parking Brake ON/Brake Fluid Low Warning Lamp	No	Continuously ON	Either one of below conditions:- 1) Park brake might be engaged 2) Brake fluid level might be low  Contact Authorized Mahindra Dealer immediately for assistance if the lamp is not turning OFF even after checking the above conditions
	Left Turn Indicators	No	Slow or Fast Blinking	Indicates left turn lamp is blinking <b>Slow Blinking:</b> Normal operation <b>Fast Blinking:</b> One / more left turn lamp bulb has fused. Have the bulb replaced
	Water in Fuel Filter Warning Lamp	Yes	Continuously ON	Indicates water in fuel filter. Drain the water from filter or contact an Authorized Mahindra Dealer for assistance
	Check Engine Lamp	Yes	Continuously ON or Blinking	There is a potential malfunction in the engine system, contact an Authorized Mahindra Dealer immediately
	High Coolant Temperature Warning Lamp	Yes	Continuously ON or Blinking	Engine temperature very high. Contact an Authorized Mahindra Dealer immediately
	Right Turn Indicators	No	Slow or Fast Blinking	Indicates right turn lamp is blinking <b>Slow Blinking:</b> Normal operation <b>Fast Blinking:</b> One / more turn signal lamp bulb has fused. Have the bulb replaced



Symbol	Warning Lamp/Tell Tale	Lamp Pre-check	Lamp Status	Action/Remarks
	Head Lamp High Beam Indicator	No	Continuously ON	Indicates head lamp high beam is ON
	Low Fuel Warning Lamp	Yes	Continuously ON	The fuel level in the fuel tank is low. Re-fuel immediately to avoid empty tank
	All Wheel Drive 4X4	No	Continuously ON	Refer Note below *
	4WD Low	No	Continuously ON	Refer Note below *
	Malfunction Lamp (OBD)	Yes	Continuously ON	There is a potential malfunction related to emission control system, contact an Authorized Mahindra Dealer immediately
	Battery Charging Warning Lamp	No Pre-check	Continuously ON	Indicates malfunction in the charging system. Contact an Authorized Mahindra Dealer for assistance
	Low Engine Oil Pressure Warning Lamp	No Pre-check	Continuously ON	Indicates engine oil pressure is low. Check oil level and top-up or contact an Authorized Mahindra Dealer for assistance

\* When 4WD LOW input is active low and it is ON, then All Wheel Drive 4X4 is also ON  
When All Wheel Drive 4X4 input is active low, only All Wheel Drive 4X4 tell tale is ON





## 5 SEATS AND SEAT BELTS



*Do not drive the vehicle unless the occupants are properly seated. Persons not properly seated and properly restrained by seat belts can be severely injured in the case of emergency braking or a collision.*

### 5.1 Driver Seat



*It is not advisable to adjust the driver seat while driving as it may divert attention of the driver and lead to accident. Adjust driver seat only when the vehicle is stationary.*

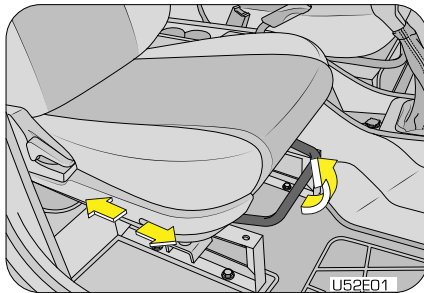

Lift the lever located underneath driver seat and move the seat forward or backward to achieve the desired position. Check and confirm that the seat is locked in the desired position.

### 5.2 Head Restraint

Your vehicle seats are equipped with head restraints which are vertically adjustable. The purpose of these head restraints is to help limit head motion in the event of a rear collision.

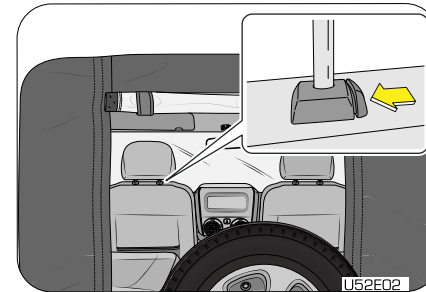

Always align top of the head restraint with the top of your head or as close to it as possible. To raise/lower the head restraint, press the lock tab and pull up / push down the restraint up.



*Never drive with the head restraints not properly adjusted, head restraints removed or inserted in a flipped condition. With no support behind your head, your neck could be seriously injured in a collision.*

### 5.3 General Warnings and Instructions- Seat Belts

At least once each month, inspect the seat belt webbing for any cuts, tears, or other signs of wear (such as fraying along the edges). Also inspect the anchors, retractors, and buckles to be sure they are tight and operational.



- All occupants, including the driver, should always wear their seat belt no matter how short the trip in order to minimize the risk of severe injury in the event of a crash. In an accident, an un-belted passenger becomes a projectile, and can cause serious injury to himself or another passenger.
- In a rollover crash, an un-belted person is significantly more likely to die than a person wearing a seat belt
- Some people believe that wearing a seat belt will lead to entrapment in the vehicle after an accident. However, your chances of surviving the initial impact, being able to unbuckle yourself and escaping from the vehicle is much greater if you are belted.
- In order to be properly buckled, you must always sit up straight and keep your feet on the floor in front of you. The lap part must be worn low and tight across your hips, just touching the top of your thighs. While fastening the seat belt, the shoulder strap of the seat belt must pass over your chest and top of your shoulder. It must never touch your neck, face, the side of your shoulder, arm, or pass under your arm. The belt must always be flat against your body and not twisted in any way. Nothing, such as an arm rest, a pocketbook, or any external objects should be between you and the seat belt. *Improper wearing* of a seat belt will reduce the protection in an *accident*.
- Seat belts should be adjusted as tightly as possible, consistent with comfort to properly secure the wearer in the seat. A slack belt will greatly reduce protection to the user, and could cause additional injuries.

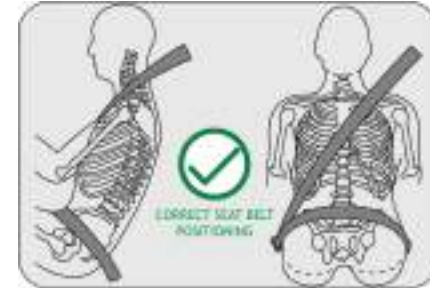

- The seat belts provided for your vehicle are designed for people of adult size, must be properly used and maintained.



- Passengers should not move out of or change seats while the vehicle is moving. A passenger who is not wearing a seat belt can be thrown against the inside of the vehicle, against other occupants, or out of the vehicle during a crash or emergency stop
- Do not use any accessories on seat belts or modify in any way the seat belt system. Devices claiming to improve occupant comfort or reposition the seat belt



can reduce the protection provided by the seat belt and increase the chance of serious injury in a crash

- An accident or emergency stop, can damage your seat belt system, even if the accident is "minor". Please have your Authorized Mahindra Dealer inspect the seat belt system after an accident

#### WARNING

*Never use a damaged seat belt system. A damaged seat belt will not provide protection in an accident, resulting in serious injury.*

- Seat belt systems can be prone to abuse. They are not indestructible. They must be handled with care to avoid damage
- Keep the belts clean and dry. Belt retraction may become difficult if the belts and webbing are soiled. If they need cleaning, use a mild soap solution or lukewarm water. Never use bleach, dye, or abrasive cleaners. These chemicals will severely weaken the belts

#### WARNING

*Never wear twisted seat belts. Excessive forces will be transferred from the belt to the wearer, in a collision, resulting in serious personal injury.*

*Each seat belt is meant for use by one person only. Using one seat belt for more than one person at a time is dangerous. The seat belt will not be able to spread the impact forces properly leading to serious injuries.*

#### **Seat Belt Usage is Necessary to:**

- Reduce the possibility of being thrown from your vehicle
- Reduce the possibility of injuries to lower body and legs during an accident
- Hold the driver in a position which allows better control of the vehicle

### 5.4 Fastening/Unfastening the Seat Belt



Adjust the seat as needed and sit up straight and well back in the seat. To fasten your seat belt, pull the webbing out of the retractor and insert the metal tab into the buckle. There will be an audible "click" when the tab locks into the buckle. Pull up on the shoulder strap to tighten the lap belt across your hips. The seat belt retractor will pull in any slack in the shoulder strap. A slow and easy motion will allow the belt to extend and let you move your body around freely.



Periodically check the seat belt as you ride to be sure it remains snug and in position. If there is a sudden stop or impact, the belt will lock into position. It will also lock (restrict) if you try to lean forward too quickly.

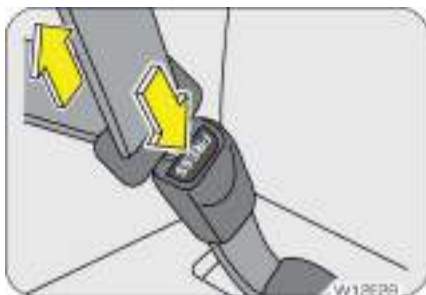

To release the belt, press the buckle release button and allow the belt to retract. If the belt does not retract smoothly, pull it out and check for kinks or twists. Then make sure it remains untwisted as it retracts.

 **WARNING**

*Never insert coins, clips, etc. in the buckle as this may prevent you from properly latching the tab and may cause damage to the buckle mechanism, thereby making the seat belt ineffective in an accident, resulting in serious personal injury.*



## 6 LOCKS AND KEYS

### 6.1 Front Doors

#### To Open the doors

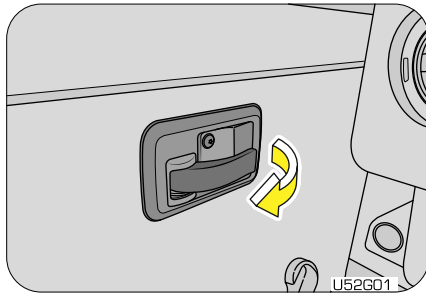

To open the door from inside, pull the door lever away from door and push the door out to open.

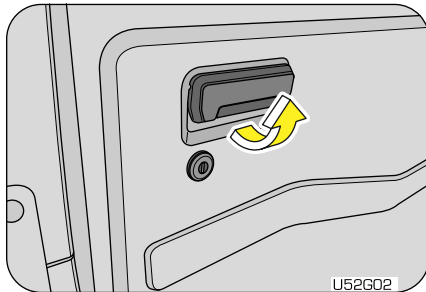

To open the door from outside, lift the door handle to unlock the door and firmly pull to swing the door open.

#### To lock the doors



The driver door can be locked/unlocked from outside using the key.



#### NOTICE

*Ensure the co-driver door is locked from inside before locking the vehicle.*



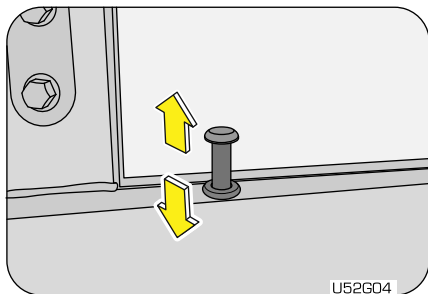

Individual doors can be locked/unlocked from inside by using door lock tabs. Lift the tab up to unlock and press the tab down to lock.

## 6.2 Tailgate

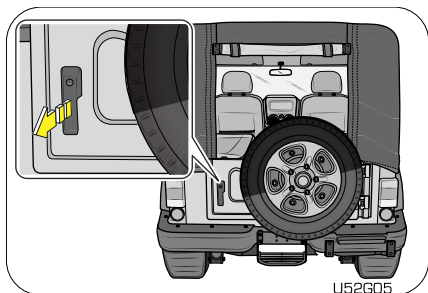

Pulling the tail gate handle outwards unlocks the tail gate and you can swing open the tail gate.

To lock/unlock the tail gate from inside, push/pull the lock tab on the tail gate down/up accordingly.

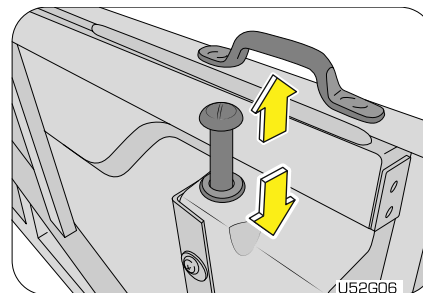

Swinging the tail gate firmly to its closed position locks the tail gate automatically.



*Driving the vehicle with tail gate in open condition is dangerous. Ensure the tail gate is locked before driving away.*



## 7 FEATURES AND CONTROL

### 7.1 Manual Windows

Manual winding windows can be lowered or raised by rotating the glass winder.

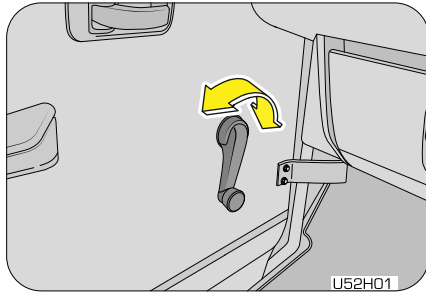

### 7.2 Outside Rear View Mirror (ORVM)

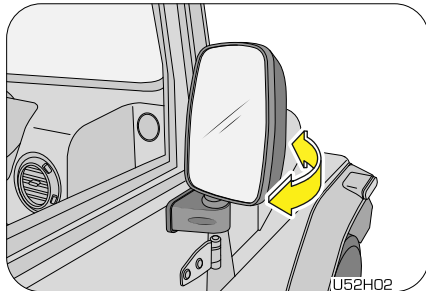

Integrated exterior rear view mirrors on both the sides facilitate maximum side and rear view information to the driver.

Both the ORVM's are hinged and may be moved either forward to unfold or rearward to fold.



#### WARNING

*Do not overestimate the distance of the objects that you see in the mirrors. Objects seen in convex mirrors are much closer than they appear.*

### 7.3 Interior Mirror (if equipped)

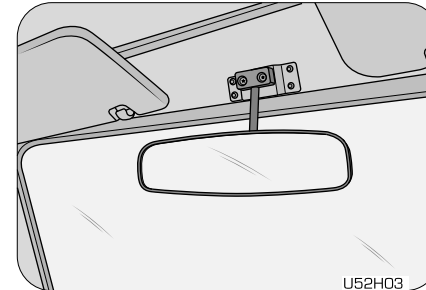

Interior mirror provides rear view information to the driver.



## 7.4 Lamps

### 7.4.1 Lighting Control Stalk

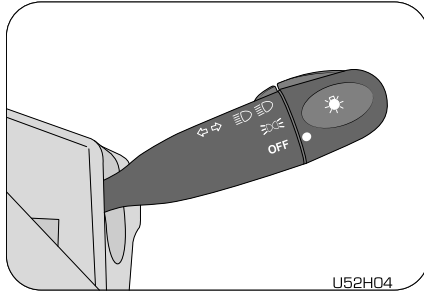

The lighting control stalk is located on the right hand side of the steering wheel and is a part of the combination switch. It controls operations of parking lamps, head lamps, head lamp beam selection, high beam flashing and turn signals when the ignition switch is ON.

### 7.4.2 Turn Signals

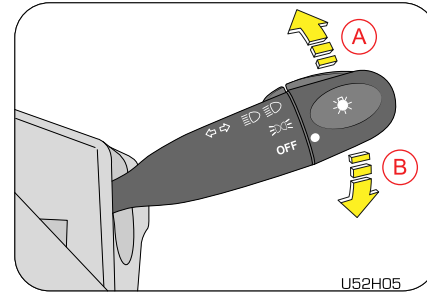

A	Turn Signal - Left	B	Turn Signal – Right
---	--------------------	---	---------------------

#### NOTICE

*After you have completed your turn, the stalk will automatically return to the neutral position switching OFF the turn signal lamps.*

*If the turn signal lamps on the instrument panel flash faster than normal, there may be a possibility that one or more of the turn signal lamp bulbs have blown. Replace the blown bulb immediately.*

*For smooth operation of turn signal switch, it is recommended to switch on turn signal before turning the steering wheel.*



### 7.4.3 Lamps OFF

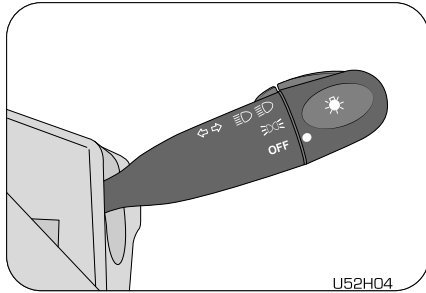

### 7.4.5 Head Lamp ON

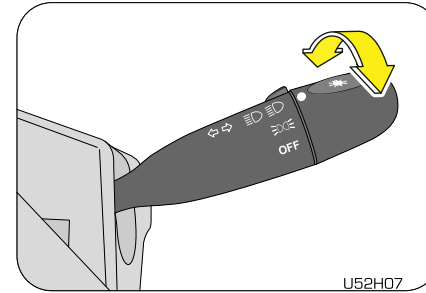

### 7.4.4 Parking Lamps ON

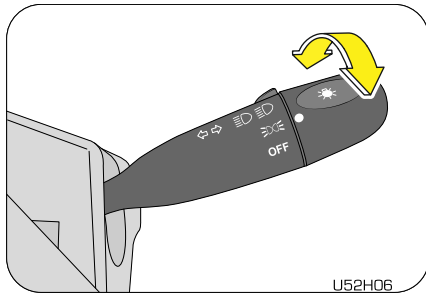

### Head lamp High/Low beam

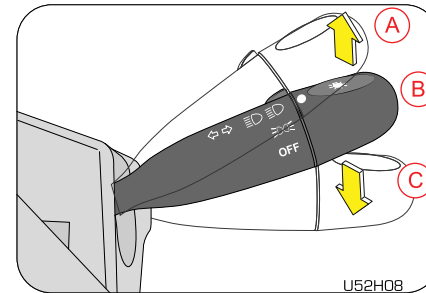

A	Head lamp Flash/Pass	B	Low Beam
C	High Beam		

### NOTICE

The tail lamp, license plate lamp and instrument panel illumination lamps are also activated when the Parking lamp is switched ON.



### Head lamp Flash

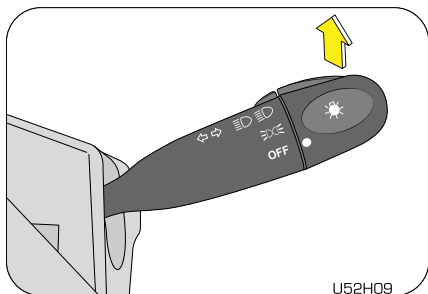

U52H09

Pull the lighting control stalk (from the head lamp low beam position) towards the steering wheel to instantaneously flash the head lamp high beam.

### 7.4.6 Head Lamp Leveling System

When the vehicle is either fully or partially loaded, it may have an upward inclination disturbing the head lamp aiming. A correct head lamp setting provides good visibility to the driver with minimum inconvenience to other road users.

To properly aim the head lamp beam, use the head lamp leveling switch. This switch is located on the right side of the steering column shroud in the instrument panel. This switch has five positions marked as 0, 1, 2, 3, 4.

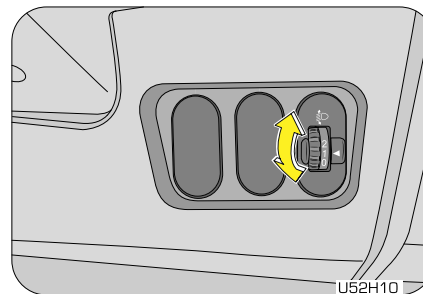

U52H10

Switch Position	Vehicle Loading Condition
0	Driver only
0	Driver + Co-driver
1	All Seated (Driver + 5)
3	All Seated (Driver + 5) + Boot Loaded
2	Driver + Boot Load as specified in GWW
4	Dummy

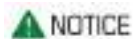

### NOTICE

*The head lamp leveling should be done when the head lamp low beam is ON.*



### 7.4.7 Courtesy Lamp

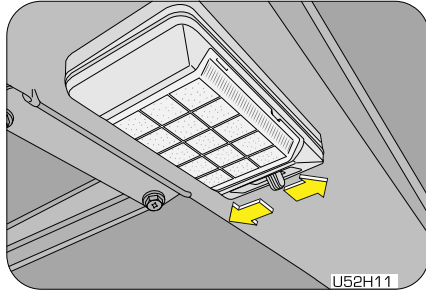

The courtesy lamp can be switched ON/OFF by the switch on the lamp. Ensure to switch off the lamp before locking/getting out the vehicle to avoid battery drain.

### 7.4.8 Hazard Warning Lamp

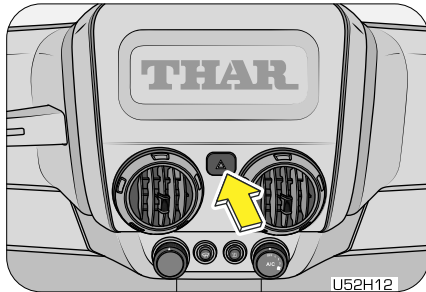

The hazard warning lamp switch is located on the instrument panel between the centre AC vents.

To turn the hazard warning lamp ON, press the switch once. All the turn signal lamps flash. The instrument cluster turn indicator lamps also flash indicating the same. To turn OFF, press the switch again.

Use the hazard warning lamp when your vehicle is stationary or to warn other road users to be cautious while passing your vehicle.



#### NOTICE

*The turn lamps do not work when the hazard warning lamps are operational.*

### 7.4.9 Power Outlet (if equipped)

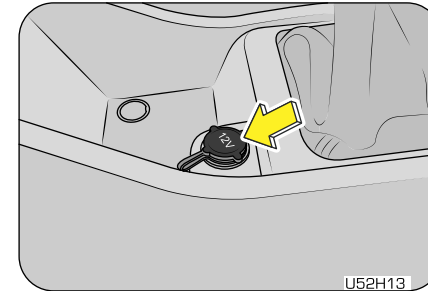

A power outlet is provided on the floor console next to the gear lever for electric-powered accessories.



#### WARNING

*To avoid serious injury:*

- *Close the power outlet cap when not in use*



- Do not allow children to use or play with the power outlet
- When using electrical appliances, strictly follow the manufacturers instruction manual
- Maximum load rating of the power outlet is 100W

### CAUTION

Accessories that draw higher power (i. e., coolers, vacuum cleaners, etc.) will drain the battery quickly and may damage the power outlet.

- Use the power outlets only when the engine is running. Remove the plug from the power outlet after using the electric device. Using the power outlets when the engine is OFF or leaving the electric device plugged in for many hours may cause the battery to drain
- Do not use the power outlet to connect electric accessories or equipment that are not designed to operate on 12V
- Some electronic devices can cause electronic interference when plugged into the power outlet. These devices may cause excessive audio noise and may interfere with other electronic systems or devices

## 7.5 Utility

### 7.5.1 Glove Box

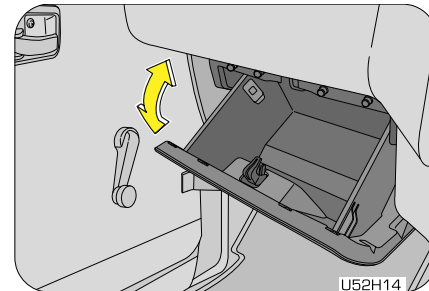
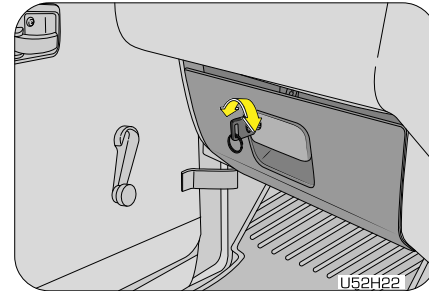

A lockable glove box is available for keeping the owner's manual and copies of all important vehicle documents. The same ignition key is used to lock the glove box.

**NOTICE**

*Do not overload the glove box.*

*Do not store loose or small metal objects inside the glove box. This will lead to rattling while the vehicle is driven on bad roads.*

**7.5.2 Sun Visor**

The sun visors can be used for either frontal or sideward (swivelled to one side) shade, to reduce glare or to shut out direct rays of the sun.

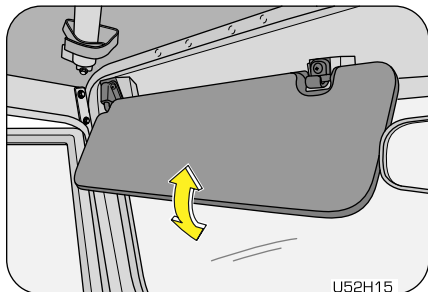
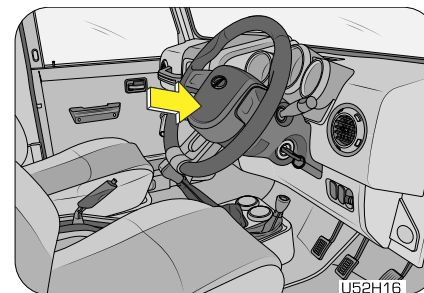
**7.6 Horn****NOTICE**

*Government of India, Ministry of Environment & Forests, has decided to issue a notification that horn should not be used at night time in silence zones and in residential areas except during a public emergency. All Mahindra vehicle owners are advised to follow this regulation thereby helping the cause of reduction of Noise Pollution.*





### 7.7 Windshield Wiper/Wash (if equipped)

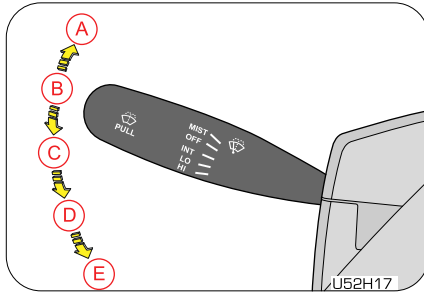

A	Mist Wipe	D	Low Speed Wipe
B	Wiper OFF	E	Hi Speed Wipe
C	Intermittent Wipe		

Move the wiper stalk towards the steering wheel from any position to activate wash function (if equipped). The wiper operates simultaneously as long as the wash function is active.

#### NOTICE

The wiper/wash function can be activated only when the ignition is in "ON" position. If you switch off the ignition before switching off the wiper, the blades stop at random on the windscreen. When the ignition is switched on again, the wiper blades return to the resting position provided the wiper/wash stalk is in OFF position.

#### CAUTION

Do not operate the wipers when the windshield is dry. It may lead to scratches on the glass. It is recommended not to use the wiper when the windshield glass is covered with debris, snow or leaves. Clean the glass before using the wiper to avoid damage to the wiper blades and glass. Do not operate the windshield washer for more than 10 seconds or when the reservoir is empty

### 7.8 Instrument Cluster

The digital instrument cluster comprises of the fuel gauge, speedometer, odometer, mode selection & reset buttons and coolant temperature gauge.

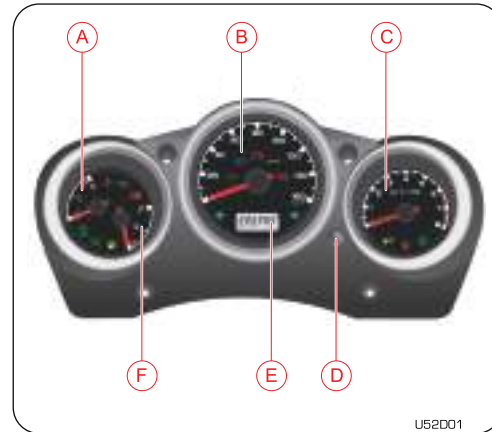



A	Temperature Gauge	D	Mode/Reset Button
B	Speedometer	E	Odometer/Tripmeter
C	Tachometer	F	Fuel Gauge

### 7.8.1 Fuel Gauge



The fuel gauge indicates the approximate level of fuel in the fuel tank. "F" indicated full tank and "E" indicates low or fuel tank empty. It is recommended to keep the tank over quarter full always to avoid air lock in fuel system.

### 7.8.2 Speedometer



The analogue speedometer indicates the current vehicle speed in kilometers per hour.



#### NOTICE

*The vehicle speed is affected by size of the tires used. If the size of the tires are changed from those fitted at the factory, the speedometer might not display the correct road surface speed and distance travelled.*



### 7.8.3 Trip meter, Odometer, Clock, Mode Button



The trip meter displays the elapsed distance travelled since the last trip reset. There are two trip meter's [A/B] which can be reset as necessary. The trip meter reading is displayed only when ignition is ON.

Odometer records and displays the total distance traveled in kilometers. The digital odometer reading is displayed only when the ignition is ON.

Clock displays the current set time in AM/PM modes. The clock reading is displayed only when the ignition is ON.

The mode button [A] is used to cycle through "Odometer - Trip A - Trip B - Clock" modes.

### 7.8.4 Engine Coolant Temperature Gauge



Engine coolant temperature gauge indicates the temperature of the engine coolant. At normal operating temperature, the needle in the gauge is half way between "C" and "H".

If the needle is all the way at "H", pull the vehicle to the side and stop the engine for a while. Restart after needle comes to the normal operating band. If the temperature again reaches the "H" band, contact Mahindra Authorised dealer for assistance.



*Do not continue driving the vehicle with a overheated engine. This will lead to damage of engine components and engine seizure.*



## 7.9 Warning Lamps in the Instrument Cluster

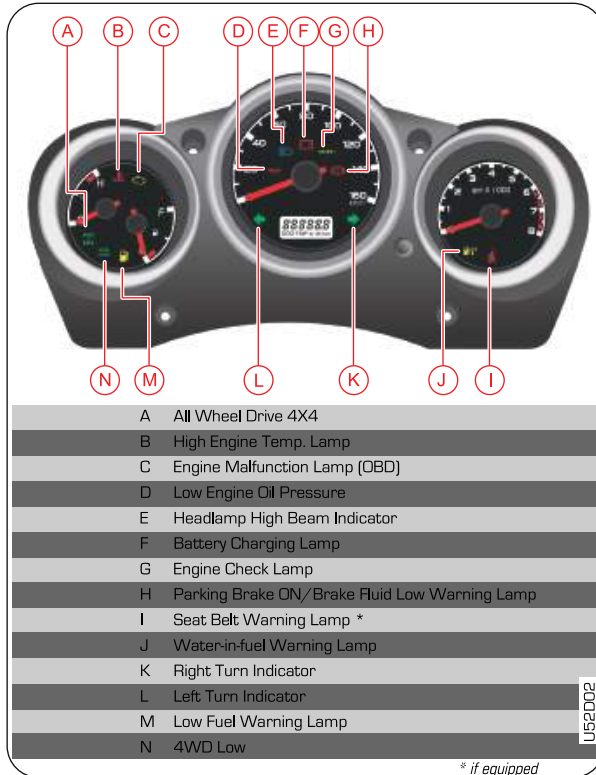

### OBD Check Lamp (BSIV only)



The OBD check lamp illuminates when the ignition is switched ON and remains ON till the engine is started indicating normal status. If the lamp remains ON, it indicates a potential engine malfunction.

There may be a malfunction in:

- The fuel management system
- The emission control system
- Systems which affect emissions

Such malfunctions may result in excessive emissions. Contact an Authorized Mahindra Dealer immediately.

### Turn Indicators



The turn lamp arrows in the instrument cluster flash showing the direction indicated by the turn signals. A sudden increase in the rate of flashing indicates failure of one or more of the lamp bulbs.

Have them replaced as soon as possible.

### Head Lamp High Beam Lamp



The head lamp high beam lamp illuminates whenever the head lamps are switched ON to high beam or when the head lamp flash is used.

### Check Engine Lamp



The check engine lamp illuminates when the ignition is switched ON and goes out in 2 seconds indicating normal status. The lamp blinks or illuminates continuously if there is a fault in the engine management system. Contact the nearest Mahindra dealer for

necessary repairs.



### Parking Brake/Low Brake Fluid Lamp



The lamp illuminates when:

- Parking brake is engaged
- Brake fluid level is low

If the lamp illuminates while driving, do the following:

- Check if the parking brake is engaged. If yes, disengage it
- Check if brake fluid level is low. If yes, top-up brake fluid (DOT 3) to the required level

If the brake lamp still continues to illuminate, immediately get the vehicle checked at an Authorized Mahindra Dealer.

#### WARNING

*Clean the top of the brake fluid reservoir before removing the cap. Make sure no dirt, impurities or other items fall into the reservoir. Do not leave the cap off for more than a few minutes. Any contaminants, impurities or moisture in the brake fluid can affect brake operation, resulting in an accident.*

*If the brake warning lamp comes ON while driving, the brake system might not be working properly. The pedal might be harder to operate or might go closer to the floor and it can take longer to stop. Pull off the road carefully and stop the vehicle. Contact the nearest Authorized Mahindra Dealer for checks or repairs.*

*Driving the vehicle with the brake warning lamp ON or when you suspect brake trouble is very dangerous and could result in serious injuries. Contact an Authorized Mahindra Dealer for checks or repairs.*



### Low Fuel Warning Lamp



When the fuel level in the fuel tank falls to the reserve limit, the low fuel warning lamp is ON. Refuel sufficiently and the lamp goes out. If the lamp continues to be ON even after refueling, contact an Authorized Mahindra Dealer.

Low fuel tell tale is OFF if fuel level is continuously above reserve level for 20 sec. whereas if fuel level is below reserve continuously for 20 sec. the low fuel tell tale is ON.

When the fuel level is extremely low, the low fuel tell tale starts to blink continuously. It is recommended to refuel immediately.

### High Engine Coolant Temperature Warning Lamp



The high engine coolant temperature warning lamp illuminates when the coolant temperature is above 105°C. Stop the vehicle and run it in idle condition for few minutes. Check the temperature gauge/LCD bars, if the temperature has reduced, you can continue driving. If not, contact an Authorised Mahindra Dealer immediately.



*Do not continue driving the vehicle with an overheated engine. This may result in engine damage, which will not be covered by the warranty.*

### Battery Charging System Warning Lamp



The battery charging system warning lamp illuminates when the battery is not being charged or when there is a malfunction in the alternator.

This lamp illuminates when the ignition is switched ON and goes out as soon as the engine is started. If the lamp continues to remain ON even after starting the engine, it is an indication that the battery is not being charged or there is a malfunction in the alternator. Check the alternator drive belt for looseness/breakage. If the drive

belt is okay, switch OFF all unnecessary electrical equipment and recheck. Contact an Authorized Mahindra Dealer for further assistance.



### Low Engine Oil Pressure Warning Lamp



This warning lamp illuminates when the ignition switch is turned ON goes out as soon as the engine is started. If the lamp remains ON even after starting the engine, or illuminates while driving, stop immediately, check the oil level after 2-3 minutes. If low, add engine oil to the "MAX" level and check status. If problem persists, contact an Authorized Mahindra Dealer immediately.



*Operating the vehicle with the low oil pressure warning lamp ON could cause sudden unexpected engine failure and loss of vehicle control, resulting in an accident, personal injury.*

*Do not run the engine with low oil pressure warning indicator ON. This may result in engine damage, which will not be covered by the limited warranty.*

### 4WD High Lamp



This lamp indicates that the vehicle is driving in the 4WD high gear. Driving in this mode gives more traction while driving on cross-country roads .

### 4WD Low Lamp



This lamp indicates that the vehicle is running in the 4WD low gear. Driving in this mode gives maximum traction while driving on all adverse conditions.



*When 4WD LOW input is active low and it is ON, then All Wheel Drive 4X4 is also ON.*

*When All Wheel Drive 4X4 input is active low, only All Wheel Drive 4X4 tell tale is ON*

### Water-in-Fuel Warning Lamp



The water-in-fuel warning lamp illuminates when the accumulation of water in the fuel filter reaches the maximum permissible limit. The fuel filter needs to be drained. Contact an Authorised Mahindra Dealer.



*Do not continue driving the vehicle with the water-in-fuel warning lamp ON. This may result in fuel pump/other fuel system component damage, which will not be covered by the limited warranty.*

### 7.10 Radio Frequency ID (RFID) Tag

Your vehicle is fitted with a RFID tag as per CMVR regulations. It is located on the top of front windshield.

RFID tag may be used for Electronic Toll Collection (ETC).



*Do not peel or remove the RFID.*



## 8 STEERING AND BRAKES

### 8.1 Steering

Your vehicle is equipped with manual steering. You may observe a substantial increase in steering effort, especially at very low vehicle speeds and during parking maneuvers.

#### WARNING

*When driving in rough/off roads, hold the steering wheel firmly. A sudden bump can jerk/ turn the wheel and injure your hand. This may also lead to loss of vehicle control.*

If the steering wanders or pulls, check for:

- Under inflated tire[s] on any wheel[s]
- Uneven vehicle loading
- High crown (mound) in the centre of the road
- High crosswinds
- Wheels out of alignment
- Wheels out of balance
- Loose or worn suspension components

### 8.2 Braking

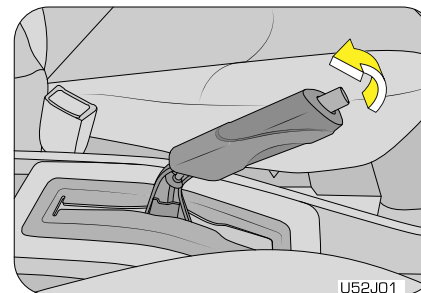

To apply the parking brake, pull the park brake lever up as firmly as possible. When the parking brake is applied with the ignition ON, the brake warning lamp in the instrument cluster illuminates. To release the parking brake, pull the parking brake lever up slightly, press the release button on the lever tip and lower the parking brake lever completely.

#### NOTICE

*The brake warning lamp indicates only the parking brake status. It does not indicate the degree of brake application. Be sure the parking brake is firmly set when parked and the gear shift lever is in gear. When parking on a hill you should apply the parking brake before placing the shift lever gear, since the load on the transmission locking mechanism may make it difficult to move the shift lever out of gear.*

#### CAUTION

*Be sure the parking brake is fully disengaged before driving off. Failure to do so can lead to brake problems due to excessive heating of the rear brakes.*





Engaging the parking brake while the vehicle is in motion can cause the rear wheels to lock up. You could lose control of the vehicle and cause an accident.

Although the parking brake is not recommended to stop a moving vehicle, if the normal brakes fail, the parking brake can be used to stop your vehicle in an emergency. However the vehicle's stopping distance increases greatly affecting the handling of the vehicle adversely.



## 9 AIR-CONDITIONING SYSTEM (AC)

AC system provided in the vehicle enables occupants to manually adjust air flow distribution pattern, air flow rate and air temperature inside passenger compartment. By appropriately adjusting the control knobs/switches provided on the AC control panel, located on center console, occupant's comfort can be ensured. AC system also helps in defrosting and defogging/ de-misting the windshield.

Air distribution mode, blower speed and air temperature can be adjusted by operating the respective control knobs. Air conditioner can be switched ON/OFF by the AC switch. Air flow direction can be further controlled by adjusting louvers of air vents.



**WARNING**  
Refrigerant used in system is a hazardous liquefied gas and is under high pressure. The refrigerant is colorless and has ethereal or faint sweetish odor. Exposure of refrigerant to skin or eyes may cause irritation and frostbite. They can also cause suffocation, dizziness and loss of concentration. When mixed with compressed air or certain other refrigerants, it may form flammable mixture. Never try to service AC system yourself which would involve refrigerant handling.

### 9.1 Overview

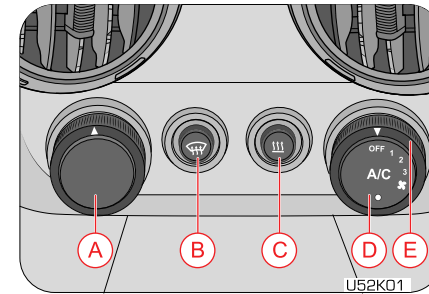

A	Temperature Control	D	AC ON/OFF Switch
B	Windshield Demister	E	Blower Speed Control
C	Heater Switch		



## 9.2 Vents

### Centre/Side Vents

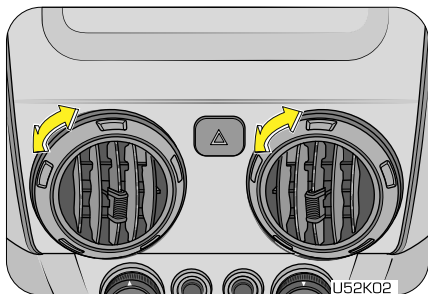

Two center vents are located on the centre console. Two side vents are located one each at the left and right extreme ends of the instrument panel.

You can direct the air flow as required by adjusting the louvers. To open/close the vent, rotate the outer ring on the vent clockwise/anti-clockwise.

### Windshield Defrost Vents

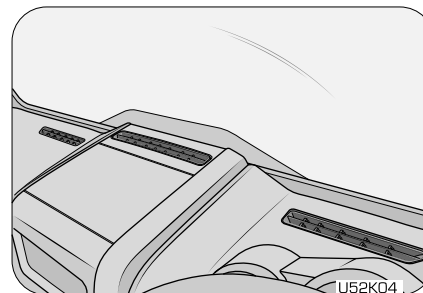

There are three windshield defrost vents in your vehicle. The windshield defrost vents help in clearing the mist from windshield.

## 9.3 AC ON/OFF

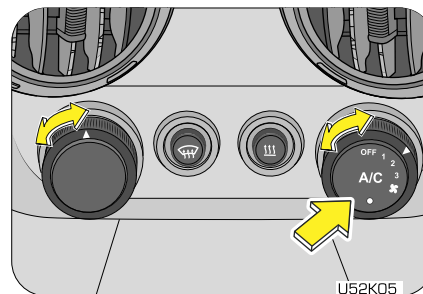

To switch ON the AC, set the blower speed and temperature control as required. Press the AC button ON.



### 9.4 Blower Speed Control

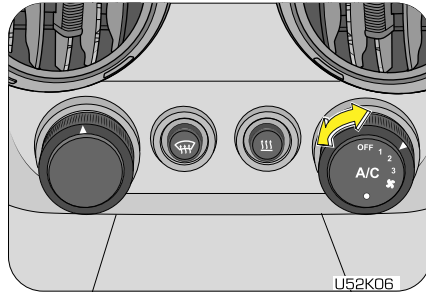

Blower force-circulates air through the AC unit and distributes it throughout the passenger compartment.

Set the blower speed between 1–3 as required. To switch OFF the blower, set the blower speed to "OFF".

#### NOTICE

*AC will function only when blower is ON.*

### 9.5 Cooling Control

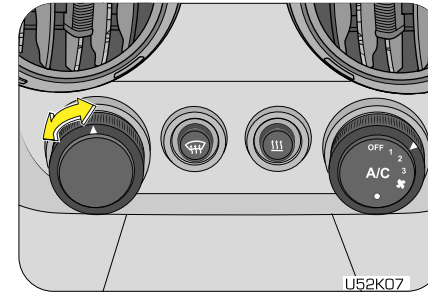

The amount of cooling can be controlled by the cooling control knob.

- Turn Clockwise — Extreme Cool
- Turn Anti-Clockwise — Normal Cool

### 9.6 Windshield De-mist

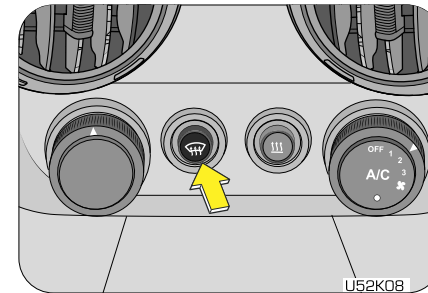



To de-mist the front windshield during rains or in cold environments, press the windshield de-mist button.

### 9.7 Heater

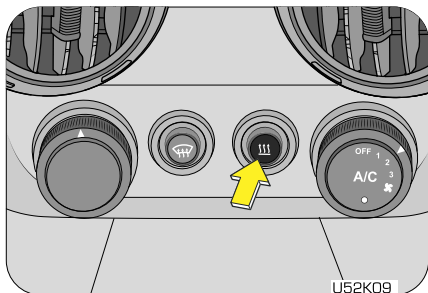

The heater can be used to heat the inside cabin, press the heater button.



## 10 STARTING AND DRIVING THE VEHICLE

### 10.1 Safety Tips - Before Starting your Vehicle

- Before starting the vehicle, inspect the inside and outside of the vehicle and look for any damages, leaks, loose parts, foreign objects/debris. Contact an Authorized Mahindra Dealer if required.
- Before starting your journey, check the working of all safety devices/components especially brakes, steering, lamps, signals and tires. In case you suspect any system/devices not working properly contact Authorized Mahindra Dealer.
- Adjust the seat, headrest (if equipped), steering wheel and fasten the seat belt as described in this manual. Never perform any adjustments when the vehicle is in motion.
- Start the vehicle only when seated and belted in the driver's seat.
- Ensure that the rear view mirror (if equipped) and both the ORVM's are adjusted for an unobstructed view of the road behind.
- Have someone observe and confirm normal operation of all exterior lamps while you work on the controls from the driver seat. Also, check functioning of all lamps in the instrument panel.
- Check all doors are properly closed and locked, both from inside and outside.

### NOTICE

*The Engine Management System controls the engine's idle speed. When the engine starts, idle RPM runs higher than normal in order to warm the engine. The engine idle speed RPM reduces once the engine warms up.*

### WARNING

*Never start your vehicle in a closed garage or in an enclosed area. Exhaust fumes can be toxic. Always keep the garage door open or start the engine in an open area.*

### 10.2 Ignition Switch

The different positions of the ignition switch are:

**LOCK** — This is the ignition and steering lock position. The vehicle circuits and engine is completely switched OFF. The steering wheel is also locked and the key can be removed from the ignition only in this position.

**ACC** — In this position all electrical circuits are enabled with the engine in OFF mode. The steering is unlocked and can be rotated. Use this mode when you want to listen to music, use the wipers, etc., with the engine temporarily switched OFF..

**ON** — This is the ignition ON position. All electrical circuits are enabled. Some of the warning or information lamps will illuminate in this position. While some of the lamps will go out after a few seconds, few will continue to remain ON till the engine is started. When the vehicle is being driven, ignition switch remains in the ON position.

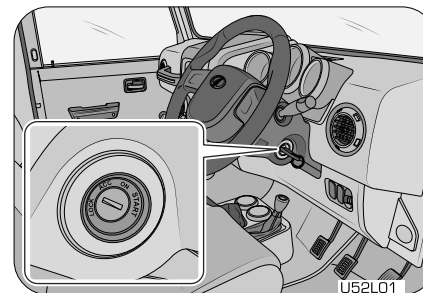



### CAUTION

Select the ignition ON position when the vehicle is being towed.

Do not leave the ignition in ON for long durations when the engine is OFF. This could lead to battery drain and ignition switch damage.

**START** — This position is to start the engine by cranking the starter motor. This is a momentary position. When the key is turned to start position, the starter cranks the engine. Once the engine is running, release the key, and the key reverts back to ON position disengaging the starter motor from the engine.

### CAUTION

Do not continue cranking after the engine has started. This will lead to damage of the starter and other engine components.

### NOTICE

If turning the key is difficult, jiggle the steering wheel from side to side and try again. The key can be removed only in the **LOCK** position. When the key is removed, the steering column lock is activated and the steering wheel cannot be turned.

### WARNING

Never return the key to the **LOCK** position or try to remove the key, when the vehicle is in motion. Removing the key allows the steering wheel to lock. You will lose control of the vehicle and may lead to a serious accident. Remove the key only when the vehicle is parked.

## 10.3 Starting the Engine

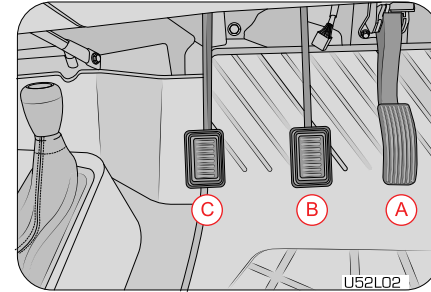

A	Accelerator	B	Brake	C	Clutch
---	-------------	---	-------	---	--------

1. Apply the park brake
2. Shift the gear lever to neutral position
3. Turn the ignition ON
4. Do not press the accelerator
5. Depress the clutch pedal
6. Turn the key momentarily to the START position to crank the engine
7. Once the engine starts, release the key; it will return to the ON position
8. If the engine fails to start, attempt to restart after about 10 Seconds
9. If the engine fails to start even after repeated attempts as per the procedure given above, contact the nearest Authorized Mahindra Dealer

**NOTICE**

Few warning lamps briefly illuminate. See "Warning Lamps in the Instrument Cluster" section for more information

**CAUTION**

To prevent damage to the starter, wait 10 seconds before attempting to restart the engine.

**WARNING**

If the vehicle battery has discharged, use booster cables, a booster battery or a battery from another vehicle to start. Jump-starting a vehicle can be dangerous if done improperly. Refer to the "Jump-starting procedure" section in this manual.

If the engine still fails to start, contact an Authorized Mahindra Dealer for assistance.

**Idling**

Once the engine has started; idle for a few seconds. The idle speed is controlled automatically and it will decrease as the engine warms up.

Observe the following when the engine is idling:

- All warning lamps are OFF
- Malfunction lamp (MIL) is OFF
- Low oil pressure lamp is OFF

After idling for a few seconds, follow the below steps to drive away;

1. Depress the service brake pedal
2. Release the park brake

3. Depress the clutch pedal
4. Shift the gear to 1<sup>st</sup>
5. Release the service brake pedal
6. Drive by releasing the clutch and pressing the accelerator pedal simultaneously.

**CAUTION**

Avoid full throttle operation when the engine is cold and prolonged idling at low ambient temperatures. Long periods of idling may be harmful to your engine.

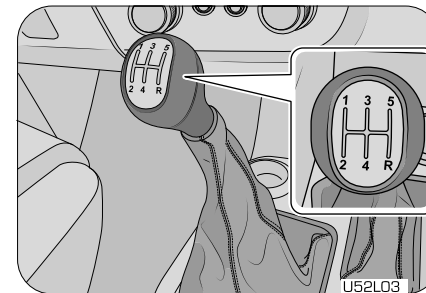
**10.4 Gear Shifting**

The gearshift pattern is shown on the gear lever knob. Press clutch pedal fully while shifting gear and then gradually release clutch. Change one gear at a time in the ascending or descending order.





## WARNING

- Prior to changing forward gears to reverse gear and reverse gear to forward gears, bring the vehicle to complete stand still.
- Reverse gear if engaged with vehicle in motion, will damage gear profiles and cause premature transmission failure.
- Abrupt gear shifting may damage gear profiles and will cause premature transmission failure.

Such failures are not covered under Mahindra warranty.

## 10.5 Driving Your Vehicle

### 10.5.1 General Driving Precautions

#### WARNING

Always observe the following precautions to minimize the risk of accidents leading to serious personal injury or damage to your vehicle

- Before you drive your vehicle, please read this manual carefully.
- When you start driving, verify proper operation of the brakes and steering system.
- If, while driving, you hear any strange noise or feel unusual vibration, or if you have any concerns whatsoever, or if any warning lamps illuminate or buzzers sound, park/stop the vehicle in a safe location as soon as possible. Identify the cause and take any necessary remedial action. Contact your Authorized Mahindra Dealer if necessary.
- Never overload or improperly load your vehicle.
- Always be attentive while driving and follow safe driving practices.
- Always maintain the recommended inflation pressure in tires.

- Always drive at a safe speed appropriate for given driving conditions.
- While backing up, keep a constant lookout for people, particularly children, or other obstructions or hazardous material that might be present behind the vehicle.
- Loaded vehicles, with a higher center of gravity, may handle differently than unloaded vehicles. Extra precautions, such as slower speeds and increased stopping distance, should be taken when driving a heavily loaded vehicle.
- Always slow down in gusty crosswinds. Because of its profile and higher center of gravity, your vehicle is more sensitive to side winds than an ordinary passenger car. Slowing down will allow you to have much better control.
- Maintain steering wheel control at all times.
- Be extremely careful when driving on pavements made slippery by loose sand, water, gravel, snow or ice.
- If your vehicle goes off the edge of the pavement, slow down, but avoid severe brake or steering application. Ease the vehicle back onto the pavement only after reducing your speed. Do not turn the steering wheel too sharply while returning to the road surface.

### 10.5.2 Off Road Driving Precautions

- When driving on off road or on rugged terrains, never over speed or make sharp turns. This may cause loss of control or vehicle rollover causing serious injury. You are also risking expensive damage to your vehicle's suspension and chassis.
- Maintain steering wheel control at all times. Sudden changes in terrain can result in abrupt steering wheel motion.
- If the vehicle goes from one type of surface to another (e.g. from concrete to gravel/sand/mud/snow) there will be a change in the way the vehicle responds, especially the way it responds to steering, braking and accelerating inputs.
- Do not drive horizontally or diagonally across steep slopes, your vehicle can tip over sideways. Driving straight up or straight down is preferred.



- Always perform a maintenance inspection after each day of off road driving that has taken you through off terrain, sand, mud or water.

### 10.5.3 Driving Through Water

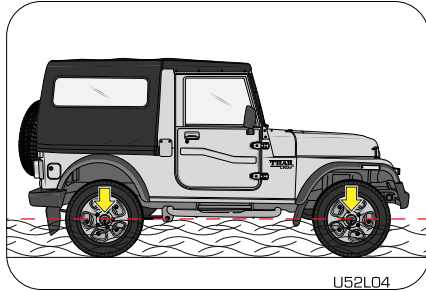

Although your vehicle is capable of driving through shallow water, there are a number of precautions that must be considered before entering the water.



*Never drive through water flowing above the bottom portion of the bumper / engine bottom shield or above the tyre centre (wheel hub) line. Not following this instruction will allow water to enter vehicle components causing internal damage to the components, affecting driveability, safety, emissions and reliability.*

*When driving through water, drive very slowly and at constant speed, less than 5 kmph. Water waves generated will be high and may enter air intake, causing severe engine damage or cause a vehicle to get stalled.*

*You must slow down while driving through shallow water. Speeding may cause water to splash onto the windshield, impairing your vision.*

- The ground under the water might not be firm which could result the water being deeper than expected when driving the vehicle through it.
- Do not stop or shut OFF the engine while immersed in water. It helps in preventing water getting inside the exhaust pipes.
- When backing down a ramp, do not allow the exhaust tail pipe to immerse in water.
- Water can wash the grease from wheel bearings, causing rusting and premature failure. It may also enter the transmission and transfer case, reducing the oil's lubricating qualities. If these are submerged in water, the lubricants should be replaced as required.
- Water entering the transmission will cause deterioration in shift quality, locking up of your transmission accompanied by vibration, and ultimately damaging the transmission.
- Sand, mud/sludge that has accumulated in brake drums and around brake discs may affect braking efficiency. This may also damage brake system components. Wet brakes cannot stop the vehicle as effectively as dry brakes. Drying can be improved by driving the vehicle slowly while applying light pressure on the brake pedal.
- When driving through water, traction or brake capability may be limited.

#### Flowing Water

- If the water is swift flowing and rising (as in storm run-off) avoid crossing until the water level recedes and/or the flow rate is reduced.
- The flowing water can erode the streambed causing your vehicle to sink into deeper water.
- Determine the exit point (s) that are downstream of your entry point to compensate for drifting.

Off-road/Water driving puts more stress on your vehicle than on-road driving. Always perform a maintenance inspection after each day of off-road driving that has taken you through rough terrain, sand, mud, or water.



- Check for accumulations of plants or bushes. These could be a fire hazard. They might also hide damage to fuel lines, brake tubes/hoses, etc.
- Inspect all the tubes/hoses and check for any fluid leakages.
- Get heat exchangers (radiator and condenser) cleaned.
- Check threaded fasteners for looseness, particularly on the chassis, drive train components, steering, suspension and brakes. Retighten them to the required torque if required.

### WARNING

*If you have been operating the vehicle in off-road conditions, get the brakes checked and cleaned as necessary. Abrasive material in any part of the brakes may cause excessive wear or unpredictable braking. You might not have full braking power when needed leading to accidents.*

*After driving through deep water, inspect your vehicle fluids and lubricants (engine oil, transmission/transfer case/axle oils) to ensure the fluids have not been contaminated.*

## 10.6 Stopping the Engine

Your vehicle is powered by a turbo diesel engine. Before turning the engine OFF, always allow the engine to return to normal idle speed and run for few seconds. This assures proper cooling and lubrication of the turbocharger. This is particularly necessary after any hard driving.

To reduce the risk of personal injury, before turning OFF the engine and leaving the vehicle, always;

- Keep your right foot on the service brake pedal
- Turn front wheels towards the road curb
- Switch OFF the ignition, turn the key to the steering lock position and remove the key

- Firmly engage the parking brake
- Move the gear shift lever to 1<sup>st</sup> gear position (reverse gear if parking on an down slope)
- Slowly release the service brake pedal
- Lock your vehicle before leaving

## 10.7 4WD System (if equipped)

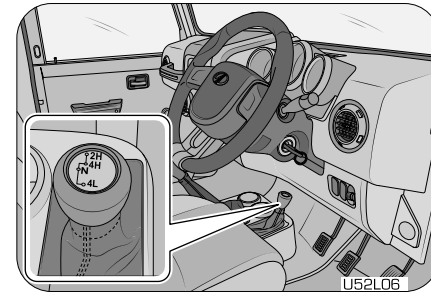

The 4WD system can be used for off-terrain driving or steep inclines like ghat sections and hill terrain regions. The 4WD/2WD shift is done by the small 4WD lever next to the gear lever. The 4WD system allows you to choose between three different modes depending on the torque requirement.

- 2H
- 4H
- 4L

**NOTICE**

You can shift to 4H mode from 2H at any speed. To engage or disengage 4L from any mode, the vehicle speed must be zero, and the transmission in neutral.

**10.7.1 Operating Instructions/Precautions**

Transfer case provides three mode positions; 2H, 4H and 4L.

**2H:** Only the rear wheels are driven at 1:1 speed ratio. Use this mode for normal driving on dry hard-surfaced roads. This position gives greater economy, quietest ride, least tire wear and better vehicle control.

**4H:** All four wheels are driven at 1:1 speed ratio. This mode provides additional traction and maximum pulling power for loose, slippery road surfaces such as ice, snow, gravel, sand and dry pavement. Front and rear drive shafts are locked together in this mode which forces the front and rear wheels to rotate at the same speed.

**4L:** Use this mode for maximum pulling power and traction. Use the 4L position for climbing or descending steep hills, off-road driving, hard pulling in sand, mud or deep snow. Driving in the 4L position on dry hard surfaced roads may cause increased tire wear and damage to driveline components. Take care not to over rev the engine and do not exceed 20 kmph when driving in this mode. When operating your vehicle in 4L, the engine speed is considerably higher than that of the 4H position at a given road speed.

**WARNING**

Because the four-wheel drive provides improved traction, there is a tendency to exceed safe turning and stopping speeds.

- Do not believe that you can go faster than road conditions permit
- Do not shift to a lower gear than necessary to maintain forward motion

- Over-revving the engine can spin the wheels and traction will be lost. You will not be able to stop or control your vehicle
- Braking performance is dramatically reduced in wet/icy/slippery conditions. Avoid abrupt downshifts on slippery roads, engine braking may cause skidding and loss of control resulting in an accident

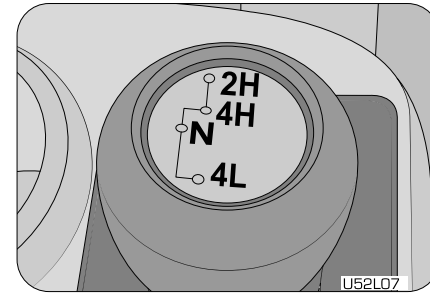
**10.7.2 Shifting Procedure****Shifting Between 2H and 4H**

Your vehicle is equipped to shift from 2H to 4H mode at any vehicle speed from 0-30 kmph. To shift from 2H to 4H, depress the clutch, move the selector lever to 4H position.

**CAUTION**

Never operate the selector 4WD lever if the wheels are slipping. Stop the slipping or spinning before operating the switch knob.

To shift from 4H to 2H, depress the clutch, move the selector lever to the 2H position. This can be done at any speed from 0-30 kmph.



### To Shift from 4H to 4L

1. Bring the vehicle to a complete stop and depress the clutch pedal.
2. Shift the four wheel drive selector lever to the 4L position.

### To Shift from 4L to 4H

1. Bring the vehicle to a complete stop and depress the clutch pedal.
2. Shift the four wheel drive selector lever to the 4H position.

In heavy snow or when pulling a load, or for additional control at slower speeds, select a low gear and/or shift the transfer case to the 4L range.

- Over-revving the engine can spin the wheels and traction will be lost
- Avoid abrupt gear shifts on slippery roads, engine braking may cause skidding and loss of control

### 10.7.3 Wheel locking Hubs [Only for 4WD vehicles] Automatic Locking Hubs

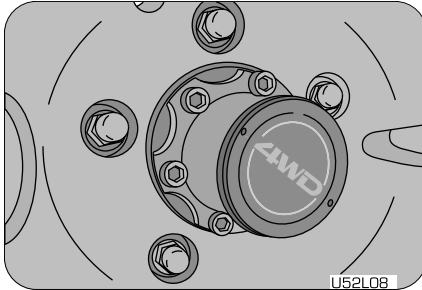

### NOTICE

*When you shift to 4WD mode, an audible 'Click' will indicate that automatic locking hubs are engaged and therefore power is being transmitted to the front wheels. While changing back to the 2WD mode the hubs need to be released.*

### To Release the locking hubs

- Shift from 4WD to 2WD
- Reverse the vehicle in a straight line for about a meter
- An audible 'Click' will indicate that the hubs have been released
- Unlocking is necessarily required to be done to isolate front axle & transfer case from transmission & from front wheels.

### CAUTION

*If auto-lock hubs make a clattering noise when driving in 2H mode, stop and move the vehicle about 2 to 3 meters in backward direction.*

### NOTICE

*When engaging & disengaging, the auto-lock hubs will make a clicking noise. It is normal.*

### 10.7.4 Do's and Don'ts

#### Do's:

- While the system is shift-on-the-fly between 2H-4H-2H, it is a good practice to stop the vehicle and then shift the transfer case lever
- Learn to use the power band. The CRDe engine performs best between 2000-3500rpm



- 4-Low [4L] is recommended for soft and boggy conditions, while 4-High [4H] may be used in places where speed may be required. For example – Sand
- Always use 4L to descend steep slopes to take maximum advantage of engine braking
- After shifting to 2-Wheel Drive, make it a practice to unlock the auto-hubs by reversing a few metres to reduce wear and tear on the front axle
- While ascending or descending hills, always be parallel to the slope to ensure maximum stability of the vehicle.

#### Don'ts:

- Avoid taking the engine to the redline (maximum rpm). It's not only inefficient but it also means you're not getting the maximum power from the engine
- Never half-clutch in off-road. Make it a practice to use it only to change gears. This will prolong clutch life and is also safer in off-road situations as you can utilise maximum engine braking
- Do not drive with 4-Wheel Drive engaged [4H, 4L] on the road to avoid damage to the gearbox. The Thar is a part-time 4WD and is not meant to be driven in 4WD on the road
- Take care of your auto-lock hubs by avoiding landing after jumps with power applied
- Do not press the clutch while descending steep hills as you may lose control of the vehicle. Always descend in-gear
- Do not shift between 4H-4L-4H while vehicle is in motion. Always stop the vehicle and then shift the transfer case lever.

## 10.8 Fuel

Use commercially available vehicular Ultra-low Sulfur Highway Diesel that meets the BIS standard (IS 1460; 2010 BS IV / BS III specification or equivalent).

### CAUTION

*Do not fill the fuel tank or mix the fuel with gasoline, alcohol based fuels, kerosene, etc. This will damage the engine, fuel and exhaust system components.*

*If you have accidentally filled the fuel tank with incorrect or non-approved fuel, do not start the vehicle. Contact an Authorized Mahindra Dealer to have the fuel system drained completely.*

It is recommended maintaining a minimum of 10 liters of fuel in the fuel tank. Driving the vehicle till the fuel tank is empty is not recommended. Always have sufficient fuel in the tank. Check the fuel level prior to starting your journey.

### WARNING

*Never carry fuel in separate containers in the vehicle, it is dangerous and may lead to inadvertent fuel leak or spillage.*

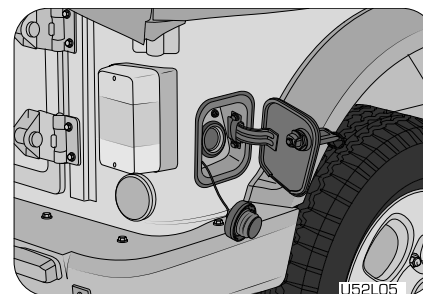

Fuel is filled in the fuel tank through the filler neck provided on the right side of the vehicle. Unlock the fuel lid using the key, turn the fuel cap counter-clockwise to open. Refuel and put the cap back in its place and tighten in the clockwise direction till you hear distinct clicks. Lock the fuel lid before driving away.



### CAUTION

Ensure the fuel cap is securely closed before starting the vehicle.

### WARNING

- Fuel spray can burn skin or eyes if contacted and can cause illness if ingested.
- Fuel spilled on the vehicle body could damage paint. Flush it with water and detergent.
- Do not refuel with engine running.
- Always keep sparks or open flames away from the filler neck.
- Smoking is injurious to health. Smoking when refueling adds risk of fire or explosion.
- Do not attempt to start the engine, if you have filled the tank with incorrect fuel. This could damage the engine severely. Have the system checked by a Mahindra authorized dealer immediately.

#### 10.8.1 Tips for Better Fuel Economy

Give due consideration to the points listed below for better performance of vehicle and enhance fuel economy.

- Steady speeds without stopping will usually give the best fuel economy
- Idling for long periods of time may waste fuel
- Anticipate stopping; slowing down may eliminate the need to stop
- Sudden or hard accelerations reduce fuel economy
- Slow down gradually
- Drive at moderate speeds

- Rewinding the engine before turning it off may reduce fuel economy
- While idling put the gear shift lever in neutral position
- Resting your foot on the clutch pedal while driving may reduce fuel economy
- Combine errands and minimize stop-and-go driving
- Keep tires properly inflated. It is recommended to check your tire pressure in the morning when the tyre is cold
- Use recommended engine oil. Refer to the Maintenance Section for specifications and capacities
- Replace the fuel filter and air filter at the recommended intervals
- Shift gears at the recommended speeds and rpm bands only
- Follow the recommended maintenance schedule
- Heavily loading a vehicle or towing a trailer will reduce fuel economy
- Carrying unnecessary weight may reduce fuel economy
- Driving on flat terrains offer improved fuel economy as compared to driving on hilly terrains

#### 10.8.2 Calculating Fuel Efficiency

1. Re-fuel your vehicle till the auto-cut-off mode
2. Reset trip meter to zero
3. Drive at moderate speed for minimum distance of 100 km
4. Re-fuel at the same fuel station till the auto-cut-off mode.  
Assume "a" liters of fuel was filled and "b" was the trip meter reading.
5. Fuel Efficiency =  $b/a$  kmpl



# 11 WHEELS AND TIRES

## NOTICE

Refer to the "Flat Tire" section in the General chapter for changing a flat tire.

### 11.1 Tire Pressure

Proper tire inflation pressure is essential to the safe and satisfactory operation of your vehicle. Three primary areas are affected by improper tire pressure;

- Safety
- Economy
- Ride Comfort and Vehicle Stability

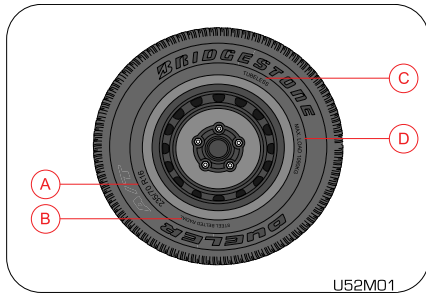

A	Tire size
B	Radial tires or bias-ply tire - A radial tire has "RADIAL/ STEEL BELTED RADIAL" on the sidewall. A tire not marked with "RADIAL" is a bias-ply tire.

C	"TUBELESS" or "TUBE TYPE" - A tubeless tire does not have a tube inside the tire and air is directly filled in the tire. A tube type tire has a tube inside the tire and the tube maintains the air pressure.
D	Max Load Limit

Your vehicle is originally equipped with tires supplied by a reputable manufacturer. If you ever have any questions regarding your tires, please refer to literature supplied by the tire manufacturer, or to the separate tire warranty provided by the tire manufacturer. You may also contact Mahindra directly, or the tire manufacturer.

The tire rating of your vehicle is **235/70 R 16 105S**

Tire rating is explained as below;

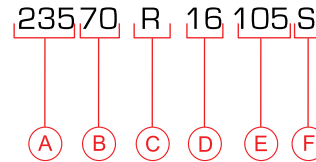

#### Tire size (example: 235/70 R16 105S)

**(A):235 (Three-digit number):**This number gives the width in millimeters of the tire from sidewall edge to sidewall edge. This is called as "Section Width".

**(B):70 (Two-digit number):**This number, known as the aspect ratio, gives the tires ratio of height to section width.





- (C): R:**This is the Tire Construction Code. The “R” stands for Radial.
- (D):16 (Two-digit number):**This number is the wheel or rim diameter in inches.
- (E):105 (Two or three digit number):**This number is the tires load index. It is a measurement of how much weight each tire can support.
- (F):S:**Tire speed rating or speed symbol. Never drive the vehicle faster than the tire speed rating. The speed rating denotes the speed at which a tire is designed to be driven for extended periods of time under a standard condition of load and inflation pressure. S denotes a speed rating of 180 km/hr.

**Speed Rating**

SPEED SYMBOL	MAX SPEED CAPABILITY	SPEED SYMBOL	MAX SPEED CAPABILITY
	KM/HR		KM/HR
L	120	T	190
M	130	U	200
N	140	H	210
P	150	V	240
Q	160	W	270
R	170	Y	300
S	180	Z	240+

**Tire Pressure Placard**

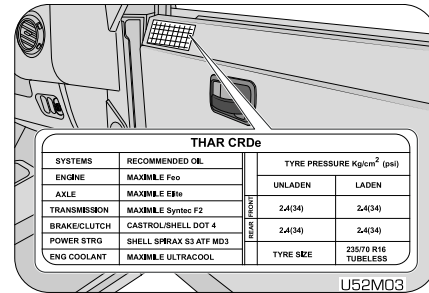

TIRE INFLATION PRESSURE kg/cm <sup>2</sup> (Psi)	
Front	2.4 kg/cm <sup>2</sup> (35 Psi)
Rear	2.4 kg/cm <sup>2</sup> (35 Psi)

Tire Label (Vehicle Placard) tells you important information about tire size designed for your vehicle, and the laden/unladen tire inflation pressures for the front & rear tires. The label is pasted above the driver door trim.



*Never overload your vehicle. Overloading can cause tire failure, affect vehicle handling, and increase your stopping distance, resulting in an accident and/or personal injury.*

*Improper inflated tires can adversely affect vehicle handling or can fail unexpectedly, resulting in an accident and/or personal injury.*

*Under-inflation is the most common cause of tire failures and may result in severe tire cracking, tread separation or "blowout", with unexpected loss of vehicle control and increased risk of injury. Under-inflation increases sidewall*



*flexing and rolling resistance, resulting in heat buildup and internal damage to the tire.*

*Check and set tire pressure at ambient temperature before starting to drive the vehicle or 15 - 20 minutes after a drive.*

### NOTICE

*The tyres fitted in the vehicle meet the requirements of BIS and they would comply with the requirements under the CMVR 1989, as mentioned Notification SO 2953E.*

The service life of a tire is dependent upon various factors including but not limited to;

- Driving style
- Tire pressure
- Distance driven

### WARNING

*Do not use a tire, wheel size or speed rating other than that specified for your vehicle on the tire placard. Combinations of unapproved tires and wheels may change suspension geometric and performance characteristics, resulting in changes to steering, handling and braking of your vehicle. This can cause unpredictable handling, stress to steering and suspension components. You could lose control of the vehicle or the tire can unexpectedly fail, resulting in an accident and/or personal injury.*

### NOTICE

*Replacing original tires with tires of a different size may result in false speedometer and odometer readings.*

## 11.2 Tire Pressure

Proper tire inflation pressure is essential to the safe and satisfactory operation of your vehicle. Three primary areas are affected by improper tire pressure;

- Safety
- Economy
- Ride Comfort and Vehicle Stability

Proper tire inflation contributes to a comfortable and safe ride. Overinflating produces a jarring and uncomfortable ride. Both underinflation and overinflation affect the stability of the vehicle and can produce a feeling of sluggish response or over responsiveness in the steering. Unequal tire pressures can cause erratic and unpredictable steering response or may cause the vehicle to drift left or right.

Improper inflation pressures can cause uneven wear patterns to develop across the tire tread. These abnormal wear patterns will reduce tread life resulting in a need for earlier tire replacement. Under inflation also increases tire rolling resistance and results in higher fuel consumption.

### NOTICE

*The proper cold tire inflation pressure is listed in the Tire Label (Vehicle Placard), located on the front passenger side inner B-pillar.*

### 11.2.1 Inspection and Adjustment Procedure

The tire pressure should be checked and adjusted, as well as inspected for signs of tire wear or visible damage, at least once a month. Use a good quality pressure gauge to check tire pressure. Do not make a visual judgement when determining proper inflation. Radial tires may look properly inflated even when they are underinflated. At the same time, each tire should be inspected for signs of tire wear or visible damage.



Inflation pressures specified on the placard are always cold tire inflation pressures. Cold tire inflation pressure is defined as the tire pressure after the vehicle has not been driven for at least three hours, or driven less than 1 km after a three-hour period. Check tire pressures more often if subject to a wide range of outdoor temperatures, as tire pressures vary with temperature changes. Tire pressures change by approximately 1 psi [7 kPa] per 7°C of air temperature change. Keep this in mind when checking tire pressure inside a garage, especially in the winter.

When it was new, the spare tire in your vehicle was fully inflated. However, a spare tire can lose pressure over time. In order to avoid being stranded, check the spare tire air pressure frequently.

### 11.2.2 Inflating Your Tires

Safe operation of your vehicle requires that your tires are properly inflated. Remember that a tire can lose up to half of its air pressure without appearing flat.

At least once a month or before long trips, inspect each tire and check the tire pressure with a tire gauge (including spare tire). Inflate all tires to the recommended inflation pressure.

#### WARNING

*Under-inflation is the most common cause of tire failures and may result in severe tire cracking, tread separation or "blowout", with unexpected loss of vehicle control and increased risk of injury. Under-inflation increases sidewall flexing and rolling resistance, resulting in heat buildup and internal damage to the tire. It also may result in unnecessary tire stress, irregular wear, loss of vehicle control and accidents.*

Always inflate your tires to the recommended pressure even if it is less than the maximum inflation pressure information found on the tire. The recommended tire inflation pressure is found on the Tire Label which is located on the front passenger side inner B-pillar. Failure to follow the tire pressure recommendations can cause uneven tread wear patterns and adversely affect the way your vehicle handles.

#### NOTICE

*If you overfill the tire, release air by pushing the metal stem in the center of the valve. Then recheck the pressure.*

#### WARNING

*After inspecting or adjusting the tire pressure, always reinstall the valve stem cap (if equipped). This will prevent moisture and dirt from entering the valve stem, which could damage the stem, resulting in an unexpected loss of tire pressure, an accident and/or personal injury.*

### 11.2.3 Radial Ply Tires

#### WARNING

*Combining radial ply tires with other types of tires on your vehicle will cause your vehicle to handle poorly, resulting in an accident and/or personal injury. Always use radial tires in sets of four. Never combine them with other types of tires.*

*Cuts and punctures in radial tires are repairable only in the tread area because of sidewall flexing. Consult your authorized dealer for radial tire repairs.*

### 11.2.4 Tread Wear Indicators (TWI)

Tread wear indicators are molded into the bottom of the tread grooves. They will appear as bands when the tread depth becomes 1/16 inch [2 mm]. When the indicators appear in two or more adjacent grooves, the tire should be replaced.

#### CAUTION

*Avoid abrupt maneuvering and braking. This can cause tire deterioration and lead to loss of steering or braking control.*



### 11.2.5 Life of Tire

The service life of a tire is dependent upon various factors including but not limited to;

- Driving style
- Tire pressure
- Distance driven

#### WARNING

*Tires and the spare tire should be replaced after six years, regardless of the remaining tread. Failure to follow this warning can result in sudden and unexpected tire failure, leading to an accident and/or personal injury.*

#### NOTICE

*Keep dismantled tires in a cool, dry place with as little exposure to light as possible. Protect tires from contact with oil, grease and fuels.*

#### WARNING

*Do not use a tire, wheel size or speed rating other than that specified for your vehicle on the tire placard. Combinations of unapproved tires and wheels may change suspension geometric and performance characteristics, resulting in changes to steering, handling and braking of your vehicle. This can cause unpredictable handling, stress to steering and suspension components. You could lose control of the vehicle or the tire can unexpectedly fail, resulting in an accident and/or personal injury.*

#### NOTICE

*Replacing original tires with tires of a different size may result in false speedometer and odometer readings.*

### 11.2.6 Snow Chains

Snow chains cannot be used on these tires.

#### WARNING

*In case of harsh winter driving conditions, it is recommended using winter tires with the same specifications for better stability, safety and performance.*

### 11.3 Tire Rotation Recommendations

#### Type 1 - Applicable for all 5 Steel / 5 Alloy wheels

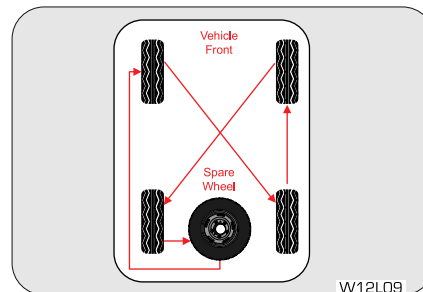

Tires on the front and rear axles of vehicles operate at different loads and perform different steering, handling, and braking functions. For these reasons, they wear at unequal rates and develop irregular wear patterns.

Rotation will increase tread life, help to maintain mud, snow, and wet traction levels, and contribute to a smooth, quiet ride. Follow the recommended tire rotation frequency for your type of driving.

**Type 2 – Applicable for 4 Alloy wheels and Spare wheel with Steel rim**

It is recommended rotating the tires as per the "Maintenance Schedule".

The suggested rotation method is the "forward-cross" shown in the diagram. The benefits of rotation are especially worthwhile with aggressive tread designs such as those on On/Off-road type tires.

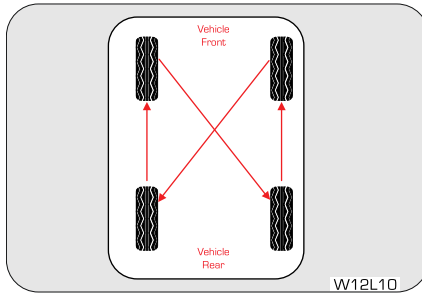

Rotation will increase tread life, help to maintain mud, snow, and wet traction levels, and contribute to a smooth, quiet ride. Follow the recommended tire rotation frequency for your type of driving. More frequent rotation is permissible if desired. The reasons for any rapid or unusual wear should be corrected prior to rotation being performed.



## 12 EMERGENCIES

### 12.1 Hazard Warning Lamp

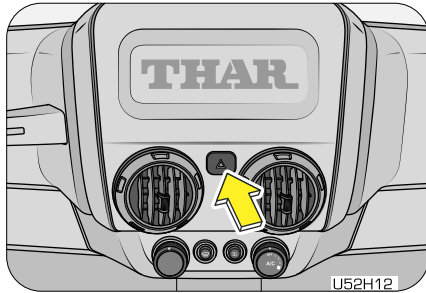

The hazard warning lamp switch is located on the instrument panel between the centre AC vents.

To turn the hazard warning lamp ON, press the switch once. All the turn signal lamps flash. The instrument cluster turn indicator lamps also flash indicating the same. To turn OFF, press the switch again.

Use the hazard warning lamp when your vehicle is stationary or to warn other road users to be cautious while passing your vehicle.

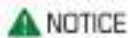

*The turn lamps do not work when the hazard warning lamps are operational.*

### 12.2 Vehicle Does not Start - Checks

Before making these checks, make sure you have followed the correct starting procedure and that you have sufficient fuel.

#### If the engine is not cranking or is cranking too slowly/ intermittently

1. Check that the battery terminals are tight and clean
2. If the battery terminals are firmly fastened, turn the interior lamps ON
3. If the lamps do not illuminate, glow dim or go OFF when the starter is cranked, the battery is weak or discharged. Try jump starting. Follow 'Jump starting' instructions given later in this chapter
4. Check the fuses in the Engine Compartment Fuse Box and Central Fuse Box

#### If the engine cranks normally, but does not start

1. If the lamp illumination is normal, engine is cranking normally, but the engine does not start even after repeated cranking, it needs adjustment or repair. Contact an Authorized Mahindra Dealer
2. During winter, use of non-winter diesel or due to extreme cold conditions, the vehicle may not start. Contact an Authorized Mahindra Dealer for further assistance



*To prevent damage to the starter, do not crank the engine for more than 15 seconds at a time. Wait 10 to 15 seconds before trying again.*

#### If the engine stalls while driving

Reduce your speed gradually, keeping a straight line. Move cautiously off the road to a safe place. Turn ON your hazard warning flashers and check for any malfunction lamps in the instrument cluster. Turn the ignition OFF, wait for approximately 90 sec and try starting the engine again. If the vehicle still does not start contact an Authorized Mahindra Dealer.



## WARNING

*If the engine stalls while running, the power assist for the brakes and steering will not work. Steering and braking will be much harder than usual.*

### **If the engine speed does not increase**

If the engine speed does not increase when the accelerator pedal is depressed, there may be a problem in the Engine Management System, electrical or electronic controls. In case of certain faults, the engine may go to limp home mode, which is indicated by the check engine lamp. Have your vehicle checked by an Authorized Mahindra Dealer as soon as possible.

## **12.3 Vehicle Overheating**

If the needle in the temperature gauge in the instrument cluster is all the way up to the H and/or the high engine coolant temperature warning lamp is ON, your engine has overheated.

Upon engine getting overheated, the Engine Management System reduces engine power substantially and may even shut the engine OFF; it is dangerous to continue driving when the engine has overheated. You need to first cool the engine down before starting to drive again.

Follow the below instructions to cool the engine down

- Progressively reduce the vehicle speed and bring the vehicle to a stop at the side of the road
- Turn ON the hazard warning flashers
- Keep the engine running at idle
- Engage the parking brake
- Switch off the air conditioner

- You can keep the AC blower speed at maximum and set the temperature control knob to the extreme end of the hot zone (clockwise end)
- Wait till the engine coolant temperature drops sufficiently such that the needle in the temperature gauge is around halfway between C and H

Now switch the engine OFF and carefully open the bonnet/hood to visibly inspect the engine cooling system parts. Be cautious while doing an inspection as vehicle parts will still be too hot. Verify that the engine coolant level in the coolant recovery tank is maintained between the 'Min' and 'Max' mark. Check for possible fluid leakages. Check for damages to heat exchangers and connecting hoses. Also verify that the radiator shrouds, engine fan blades and the engine belt all are in good condition.

If any evidence of failure is observed, contact the nearest Authorized Mahindra Dealer for help. In case, no system leakage/ failure is suspected, driving can be continued.

Either due to severe operating conditions or due to any system leakages or failures, the engine can get overheated. However if the engine is getting overheated repeatedly, even in normal operating conditions, get the vehicle checked by an Authorized Mahindra Dealer as soon as possible.

## NOTICE

*Refer to the 'High Engine Coolant Temperature' section under the 'Features and Control' chapter for details.*

## WARNING

*If the high engine coolant temperature warning is ignored, the engine shuts OFF abruptly to safeguard engine components from overheating and consequent failure. Abrupt engine shut-off can lead to uncontrollable driving condition and accidents.*

*Stay clear of hot and rotating vehicle parts while visually inspecting the vehicle. The coolant inside the cooling system is under high pressure and temperature.*



Never open the pressure cap of the degassing tank when the engine is hot. Not taking precautions may lead to serious injury to your skin/eyes.

### NOTICE

For optimum performance of the cooling system you must maintain the required coolant level and use only recommended engine coolant.

## 12.4 Jump Starting

If your vehicle's battery has run down, you may be able to start the engine by using a standalone booster battery or a vehicle with a good condition battery.

But before going ahead with this procedure ensure that the battery is the cause of vehicle not starting. To confirm this, few simple tests can be conducted as follows;

- **Check the headlights** - Are they dim or bright? If they are dim, it's likely your battery is dead. If your headlights are bright, you do not have a dead battery and a jump start may not help
- **Try to start your vehicle**-Does it turn over very slowly, or does it crank quickly? If it cranks quickly, you do not have a dead battery and a jump start may not help. If it cranks slowly, or not at all, you probably have a dead battery

Open the bonnet and locate the battery (near the left side fender). Identify the positive and negative terminals.

- The positive terminal will be marked with a plus sign (+) and will usually have a **RED** cable attached on it.
- The negative terminal will be marked with a minus sign (-) and will usually have a **BLACK** cable attached to it

Check the physical condition of the battery. Inspect batteries for cracks, leaks or any other damage. If you find any of these things, do not jump start the vehicle. Call Mahindra Road Side Assistance or replace the battery. If the weather is very cold,

remove the refill caps and check the condition of the electrolyte. If it seems slushy or like ice, do not attempt jump-starting until it thaws.

1. Park the working vehicle near the disabled vehicle. Park the vehicle in such a way that the distance between both vehicle batteries is as small as practical. Turn off the engine, radio, lights, A/C, fans and all other electrical components. Make sure that all of these things are OFF in the disabled vehicle, too



### WARNING

*Don't let the vehicles touch each other.*

2. Wear safety gear (goggles or face guard and gloves) if you have it.





### WARNING

*It may be necessary to remove the disabled vehicle's battery cables from the battery terminals and clean both cables and terminals. Use a stiff wire brush to remove all corrosion. Reconnect the cables to the battery terminals and jump the vehicle.*

3. Untangle and unwind your jumper cables. Like your batteries, your jumper cables will probably have red and black cables and will have heavy duty clamps to connect to the battery terminals. You must make sure that the red and black ends of your jumper cables never touch each other once they are connected to the batteries; permitting them to do so can result in serious arcing and/or damage to one or both vehicles
4. Connect the jumper cables in the order described below;
  - Connect one red clamp to the positive (+) terminal of the dead battery/disabled vehicle
  - Connect the other red clamp to the positive (+) terminal of the good battery
  - Connect one black clamp to the negative (-) terminal of the good battery
  - Connect the other black clamp to a piece of grounded metal on the dead vehicle, preferably shiny metal (not painted or oily) that is attached to the

engine. Usually a nut, bolt or other protruding shiny metal will work. You may see a small spark when you connect to a good ground. As a last resort, you may connect to the negative (-) post of the dead battery, but this risks igniting hydrogen gas coming off the battery

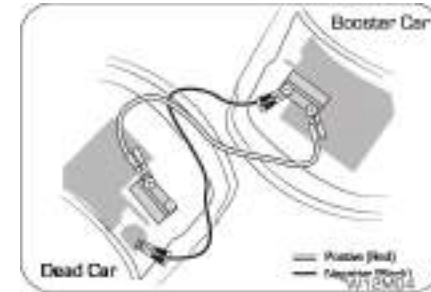

### WARNING

*Make sure none of the cables are dangling into the engine compartment, where they could be exposed to moving parts.*

5. Start the working vehicle. Let it idle for a few minutes. Rev the engine a little above idle for 30 to 60 seconds. You do this to charge the battery in the dead vehicle. A good clean connection between the battery cables and the battery terminals is essential
6. Try to start the disabled vehicle. If it does not start, shut the engine off and disconnect the last connection temporarily while you slightly twist or wiggle each of the four clamps to help ensure a good electrical connection. Restart the working vehicle again. Allow another 5 minutes for charging before attempting to start the disabled vehicle. If this does not work after a few tries, you may need to have the vehicle towed or the battery replaced



7. Remove the jumper cables once the vehicle starts. Do this in the reverse of the order in which they were attached, and don't let any of the cables or clamps touch each other (or dangle into the engine compartment)
  - Disconnect the black clamp from the grounded metal on the dead vehicle
  - Disconnect the black clamp from the negative (-) terminal of the good battery
  - Disconnect the red clamp from the positive (+) terminal of the good battery
  - Disconnect the red clamp from the positive (+) terminal of the dead battery

Replace any positive (+) red post protective covers if applicable (You have had to remove or open these in the beginning) These covers help prevent accidental short circuiting of the battery

8. Keep the recently-disabled vehicle's engine running. Run the vehicle above idle (slightly rewed up with your foot on the accelerator). This should give the battery enough charge to start the vehicle again. If it does not, you probably have a dead battery or a dying alternator

### WARNING

*Improper jump starting procedures can result in battery explosion and acid burn hazard.*

*Loosely connected battery cables could damage the electronic control units.*

*To disconnect battery terminals wait for at least 2 minutes to allow discharge of high voltage or it could lead to personal injury.*

*While disconnecting, always disconnect the -VE terminal first and while connecting, always connect the -VE terminal last.*

### WARNING

*Towing a vehicle to start could be dangerous. The vehicle being towed could surge forward when the engine starts, causing the tow vehicles to collide, injuring the occupants.*

*Modern vehicles with electronic management systems should not be jump started without 'protected' jump starter leads. It is necessary to refer to the owner's handbook for jump starting procedures for such vehicles.*

## 12.5 Limp Home Mode

Limp home mode is an emergency situation declared by the EMS (Engine Management System) due to failure of one/more critical sensors/actuators. In this mode, the EMS (Engine Management System) will revert back to basic minimum requirement (fuel quantity / injection timings) to aid the driver to bring the vehicle back to the nearest workshop. Needless to say the drivability & fuel consumption will be greatly affected.

If vehicle acceleration worsens or if there is a drop in vehicle performance, there might be a malfunction in the engine management system which triggers/activates the Limp Home Mode. This condition is accompanied by the check engine lamp illuminating in the instrument cluster. In this mode, the vehicle speed is limited and the accelerator pedal may not function normally. It is recommended you contact an Authorized Mahindra Dealer immediately for assistance.



## 12.6 Towing

### 12.6.1 Towing Equipment

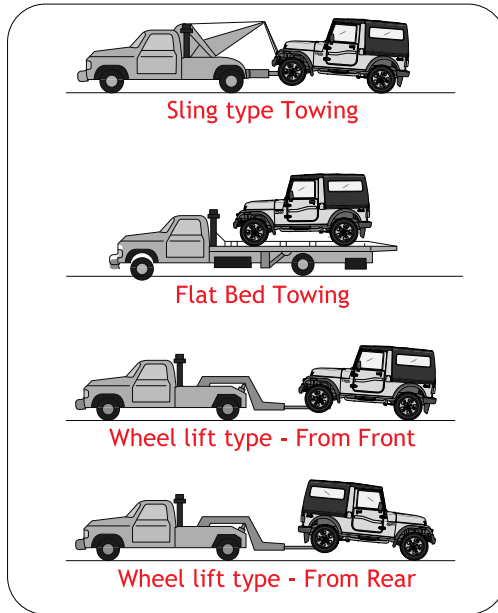

Towing equipment are of two types.

- Flat-bed equipment - Your vehicle is loaded on the back of a truck. This is the safest and best way of towing.

- Wheel-lift equipment - The tow truck uses two pivoting arms that go under the tires (front or rear) and lift them off the ground. The other two tires remain on the ground.
- Sling-type equipment - The tow truck uses metal cables with hooks on both ends. These hooks go around parts of the frame or suspension and lift the end of the vehicle off the ground. This is not a good method of towing as it may damage the vehicle's suspension and body. Avoid a tow with sling type equipment

### 12.6.2 Towing your Vehicle during Emergency

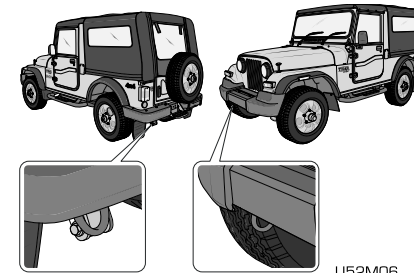

If your vehicle needs to be towed, call a professional towing service. If a towing service is unavailable in an emergency, your vehicle may be temporarily towed by a cable or chain secured to the emergency towing hook in the front of the vehicle.



*Use only the towing hook provided, for towing in an emergency. Do not tow by the bumper or any other part which may be damaged.*

*Use only the cable or chain specifically intended for use in towing vehicles.*



A driver must be in the vehicle being towed to steer and operate the brakes. Towing in this manner must be done only on hard-surfaced roads for short distances and at low speeds. Also, the wheels, axles, drive train, steering and brakes must all be in good working condition.

Avoid sudden starts or erratic driving maneuvers, which would place excessive stress on the towing hook and towing cable or chain, resulting in breaking of the hook or the chain.

If the engine is not running, the power assist for the steering and brakes will not be functional, making it harder to steer or brake than usual.





## 13 MAINTENANCE

### 13.1 General Owners Information

Your vehicle has been designed for fewer maintenance requirements with longer service intervals to save both your time and money. However, each regular maintenance, as well as day-to-day care is more important to ensure a smooth, trouble free, safe and economical operation.

It is the owner's responsibility to make sure the specified maintenance, including general maintenance service is performed. Note that both the new vehicle limited warranty and emission control system limited warranties specify that proper maintenance and care must be performed. See Service Coupon Booklet for complete warranty information.

#### Where to go for service?

Mahindra technicians are well trained specialists and are kept up to date with the latest service information through technical bulletins, service tips and in dealership training programs. They learn to work on Mahindra vehicles before they work on your vehicle, rather than while they are working on it.

You can be confident that your Mahindra dealer's service department does the best job to meet the maintenance requirements on your vehicle reliably and economically.

### Get the most from your vehicle with routine maintenance

Routine maintenance is the best way to help ensure you get the performance, dependability, long life and better resale value you expect from your vehicle. This is exactly why we've put together this Maintenance Section. It outlines the services required to properly maintain your vehicle and when they should be performed. The focus is on maintaining your vehicle while it's running great, which goes a long way toward preventing major repairs and expenses later.

Here are a few suggestions to help you get started on routine maintenance:

- Familiarize yourself with your vehicle by going through your Owner's Manual
- Take a few minutes to review this Maintenance Section
- Make it a habit to use this manual to record scheduled maintenance in the Service Coupon Booklet
- Consult with your Authorized Mahindra Dealer for all your vehicle's needs

#### 13.1.1 Suggestions for Obtaining Service for your Vehicle

##### Prepare for the Appointment

If you have warranty work to be done, be sure to have the right papers with you. All work to be performed may not be covered by the warranty. Discuss additional charges with the service manager. Keep a maintenance log of your vehicle's service history.



## Prepare a List

Make a written list of your vehicle's problems or the specific work you want done. If you've had an accident or work done that is not on your maintenance log, let the service advisor know about it.

## Be Reasonable with Requests

If you list a number of items and you must have your vehicle by the end of the day, discuss the situation with the service advisor and list the items in order of priority.

### 13.1.2 Need Assistance?

It is recommended talking to an Authorized Mahindra Dealer service manager first. Most matters can be resolved with this process. If for some reason you are still not satisfied, talk to the general manager or owner of the dealership.

If an Authorized Mahindra Dealership is unable to resolve the concern, you may contact any Mahindra Customer Care executive. They would need the following information:

Owner's name and address, owner's telephone number (home and office), Authorized Dealership name, Vehicle Identification Number (VIN), vehicle delivery date and mileage.

### 13.1.3 Warranty Information

Read the Warranty Information given in the '**Warranty Information & Maintenance Guide**' for the terms and provisions of Mahindra warranties applicable to this vehicle. Mahindra genuine parts, fluids, lubricants and accessories are available at any Authorized Mahindra Dealer. They will help keep the vehicle operating at its best.

### 13.1.4 Protect your Warranty

Routine maintenance is not only the best way to help keep your vehicle performing as intended, it's also the best way to protect your warranty. Failure to perform

scheduled maintenance specified in the Service Coupon Booklet will invalidate warranty coverage on parts affected by the lack of maintenance. We can't stress enough how important it is to keep records of all maintenance. Damage or failures due to neglect or lack of proper maintenance are not covered under warranty.

Keeping **maintenance records** is easy with the service coupon booklet

It's important to document the maintenance of your vehicle. For your convenience to maintain records of service, the scheduled maintenance coupons are provided in the service coupon booklet. Every time you bring your vehicle in for scheduled maintenance, be sure to present this booklet and certify the work. Also record the date of service and mileage at the time of service. This will make record keeping easy and, should your vehicle ever require warranty coverage, you will have all the documentation to show you've properly maintained it.

### 13.1.1 Maintenance Interval

Mahindra establishes recommended maintenance intervals based upon engineering testing to determine the most appropriate mileage to perform the various maintenance services. This protects your vehicle at the lowest overall cost to you. Mahindra recommends that you do not deviate from the maintenance schedules presented in this Maintenance Schedule.

#### 13.1.1.2 Oils, Fluids and Flushing

In many cases, fluid discoloration is a normal operating characteristic by itself, and does not necessarily indicate a concern or that the fluid needs to be changed. However, discolored fluids that also show signs of overheating and/or foreign material contamination should be inspected immediately by a qualified expert such as the factory trained technicians at your Authorized Mahindra Dealer. Your vehicle's oils and fluids should be changed at the specified intervals or in conjunction with a repair.



### 13.1.1.3 Chemicals and Additives

Non-Mahindra approved chemicals or additives are not required for factory recommended maintenance. In fact, Mahindra recommends against the use of such additive products unless specifically recommended by Mahindra for a particular application.

Your vehicle is very sophisticated and built with multiple complex performance systems. Every manufacturer develops these systems using different specifications and performance features. That's why it's important to rely on your Authorized Mahindra Dealer to properly diagnose and repair your vehicle.

When planning your maintenance services, consider your Authorized Mahindra Dealer for all your vehicle's needs.

### 13.1.1.4 Get the most from your service and maintenance visits

Getting your vehicle serviced at an Authorized Mahindra Dealer adds great value to your vehicle in number of ways. Hence, it is recommended to service your vehicle at an Authorized Mahindra Dealer only.

### 13.1.5 Vehicle Self Maintenance - General Precautions

- Refer to relevant sections of the manual before starting
- Set the parking brake
- Block the wheels to prevent the vehicle from moving unexpectedly
- Turn OFF the engine and remove the key
- Stay clear of hot vehicle parts
- Avoid repeated contact with fluids
- Do not let fuel, coolant and other fluids spill over electrical and hot vehicle parts

- Keep all open flames and other burning material like cigarettes away from the battery and all fuel related parts



*Do not start/run the engine when any engine/peripheral parts are removed.*

### 13.2 Opening/Closing the Hood

The hood release lever is located in the driver side foot well area, below the instrument panel. To open the hood, follow the steps below;

1. Pull the lever to release the hood

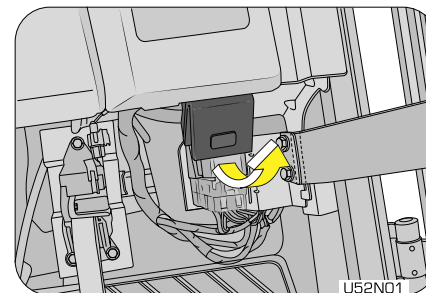





2. Lift the hood lock lever on either sides of the hood to unlock

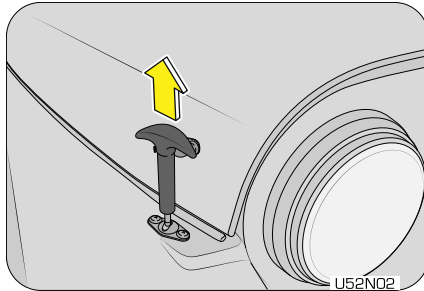

3. Lift the hood and support it by the stay rod

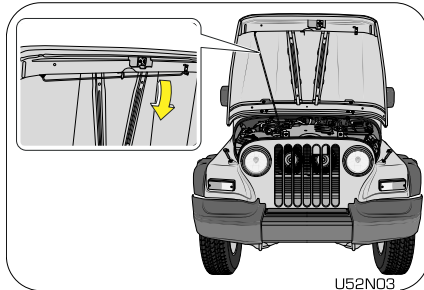

### WARNING

- *Do not open the hood immediately after a drive; the engine compartment will be very hot*
- *Always double check to be sure that the hood is firmly latched before driving away. If it is not latched properly, the hood could open while the vehicle is being driven, causing a total loss of visibility, resulting in an accident*
- *Do not move the vehicle with the hood in the raised position, as vision is obstructed*

Follow the below steps to close the hood;

1. Pull the hood down to a few inches above its fully closed position
2. Now, release the hood and allow it to fall by its own weight. The secondary latch is engaged now.
3. Firmly press the hood down with both your hands to engage the primary latch.
4. Pull the hood lock lever slightly up and hook it onto the hood on either sides



### 13.3 Identifying Components in the Engine Compartment

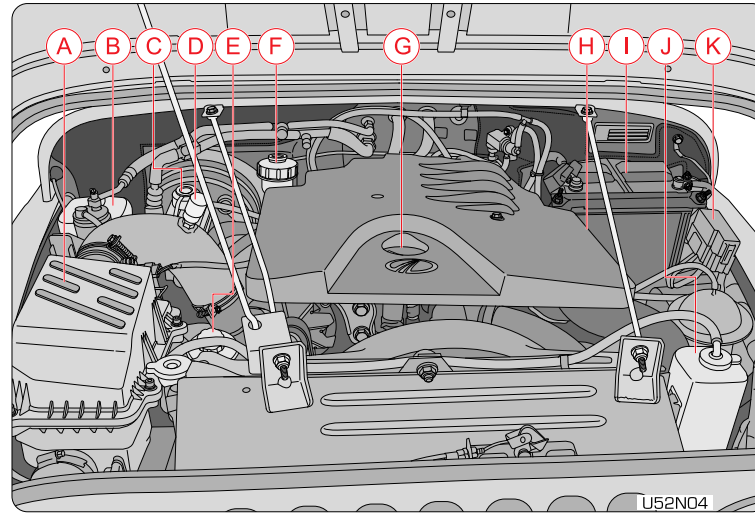

A	Air Cleaner Assembly	G	Engine Oil (Engine Oil Filling)
B	Windshield Washer Fluid Reservoir	H	Dipstick (Engine Oil Level Checking)
C	Brake Fluid Reservoir	I	Battery
D	Air Filter Service Indicator	J	Degassing Tank (Coolant Filling)
E	Power Steering Fluid Reservoir	K	Engine Compartment Fuse Box
F	Clutch Fluid Reservoir		



Maintenance is classified as below;

- General Maintenance
- Scheduled Maintenance

### 13.4 General Maintenance

#### WARNING

*Exercise extreme caution when the hood is open and engine is ON.*

Listed below are the general maintenance items that should be performed frequently. In addition to checking the items listed below, if you notice any unusual noise, fluid leakages, smell or vibration, you should investigate the cause or take your vehicle to your Authorized Mahindra Dealer or a qualified service shop immediately.

#### CAUTION

*Make these checks only with adequate ventilation if you intend to run the engine.*

#### In the Engine Compartment

- Front windshield washer fluid level
- Engine coolant level
- Battery condition
- Brake/Clutch fluid level
- Engine oil level
- Power steering fluid level
- Fluid leaks

- Hoses, joints and pipes for any abnormalities

#### Inside the Vehicle

- Lights
- Warning lamps
- Windshield wipe and wash
- Steering wheel
- Seats
- Seat belts
- Accelerator pedal
- Brake pedal
- Brakes
- Parking brake
- Gear lever shift mechanism

#### Outside the Vehicle

- Lamps
- Fluid leaks
- Doors and engine hood latches
- Tire inflation pressure
- Tire surface/thread and wheel nuts



## 13.5 In the Engine Compartment

### 13.5.1 Fluid Leaks

Check the engine compartment and the underbody of the vehicle for any leaks. If you smell fuel vapor or notice any leak, have the cause found and corrected immediately.

### 13.5.2 Engine Oil

Engine oil has the primary function of lubricating and cooling the inside of the engine. It plays a major role in maintaining the engine in proper working order. Therefore, it is essential to check the engine oil regularly.

### 13.5.3 Engine Oil Consumption

It is normal for engines to consume some engine oil during operation.

Causes of consumption in a normal engine are as follows;

- Oil is used to lubricate pistons, piston rings and cylinders. Thin films of oil, left over when pistons move in cylinders, are sucked into the combustion chamber due to high negative pressure generated when the vehicle is decelerating. This oil gets burnt in the combustion chamber
- Oil is also used to lubricate the stems of intake valves. Some of this oil is sucked into the combustion chamber together with the intake air and is burnt there
- Engine oil consumption depends upon the viscosity and quality of the oil, and upon the conditions in which the vehicle is driven. Oil consumption will be more due to high speed driving and frequent acceleration and deceleration. A new engine may consume more oil since its pistons, piston rings and cylinder walls are not conditioned

### 13.5.4 Checking/Topping the Engine Oil

- Make sure the vehicle is on level ground

- Turn the engine OFF and wait a few minutes for the oil to settle down into the oil sump
- Apply the parking brake
- Open the hood. Protect yourself from engine heat
- Locate and carefully remove the engine oil level dipstick

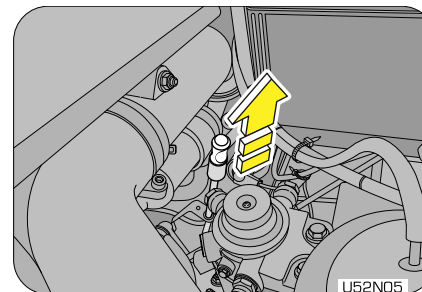

- Wipe the dipstick with a clean cloth. Insert the dipstick fully, then remove it again
- If the oil level is between 'Min' and 'Max' marks, the oil level is acceptable. **DO NOT ADD OIL**
- If the oil level is below the 'Min' mark, add enough oil through the oil filler neck to raise the level within the 'Min' and 'Max' marks. Wait for a few minutes after every top up for the oil to settle down before checking the level.

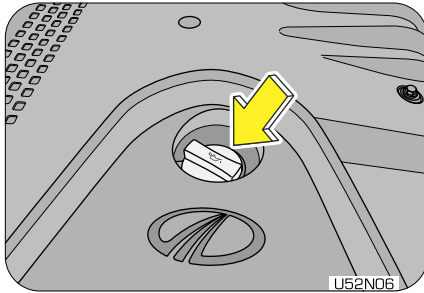

- Oil levels above the 'Max' mark may cause engine damage/poor performance.
- Put the dipstick and the oil filler cap back and ensure it is fully/ properly seated.

**CAUTION**

To avoid possible oil loss and injury due to hot blow-by gas, **DO NOT** operate the vehicle with the engine oil level dipstick and/or the engine oil filler cap removed.

**NOTICE**

Draining/Changing of engine oil should always be done by an Authorized Mahindra Dealer.

**13.5.5 Checking/Topping Engine Coolant Level**

- Park the vehicle on a flat-horizontal surface. Keep the parking brake fully engaged. Shut-off the engine

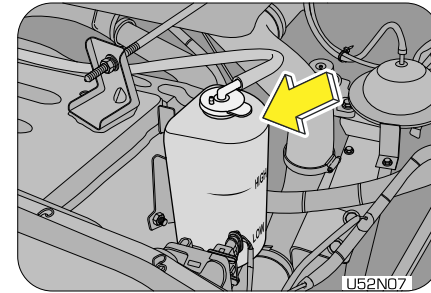

- Wait till the engine cools down and hence coolant temperature comes down to normal room temperature
- The coolant level should be between 'MIN' and 'MAX' marking provided on the coolant recovery tank
- In case the coolant level is below the 'MIN' marking, the coolant should be topped-up
- The coolant should be filled till the level rises above the 'MIN' but remain below the 'MAX' marking on the coolant recovery tank
- However if the Coolant Recovery Tank is found to be near empty, it is recommended that the system be checked at an Authorized Mahindra Dealer

**WARNING**

Never open the pressure cap when the engine is hot. Hot coolant may splash resulting in serious personal injury or severe burns by the erupting liquid.

**NOTICE**

Top up only with recommended Ready-To-Use (RTU) coolants for ensuring performance, anti-freezing and corrosion protection. Do not add water directly.



Mixing with other brands of coolant is not recommended and should be avoided.

### NOTICE

Draining or changing of engine coolant should always be done by an Authorized Mahindra Dealer.

#### 13.5.6 Checking/Topping Brake Fluid

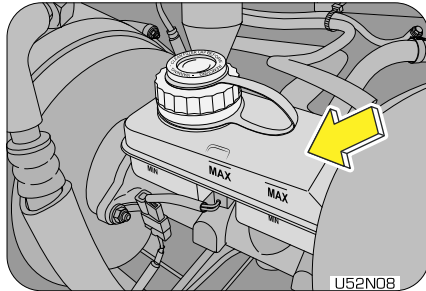

The brake system is supplied with brake fluid from the brake fluid reservoir located adjacent to the air filter.

The brake fluid level will drop slowly as the brakes wear, and will rise when the brake components are replaced. Fluid levels between the 'MIN' and 'MAX' lines are within the normal operating range; there is no need to add fluid. If the fluid levels are below the 'MIN' mark, the performance of the systems could be compromised; the brake operation could be spongy.

Top-up the recommended brake fluid till the 'MAX' mark or contact an Authorized Mahindra Dealer immediately.

Carefully clean the cap on the reservoir before you remove it and be sure no debris fall in the reservoir. Do not keep the reservoir open for longer than necessary to add brake fluid.

Use only brake fluid that meets Mahindra specifications. Refer to the 'Lubricant and Capacities' section.

### NOTICE

Draining or changing of brake fluid should always be done by an Authorized Mahindra dealer.

#### 13.5.7 Checking/Topping Clutch Fluid

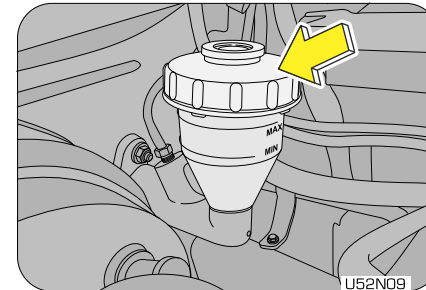

The clutch system is supplied with clutch fluid from the clutch fluid reservoir located adjacent to the brake fluid reservoir on the firewall.

Fluid levels between the 'MIN' and 'MAX' lines are within the normal operating range; there is no need to add fluid. If the fluid levels are below the 'MIN' mark, the performance of the systems could be compromised; the clutch operation could be spongy and gear change harder.



Top-up the recommended clutch fluid till the 'MAX' mark or contact an Authorized Mahindra Dealer immediately.

Carefully clean the cap on the reservoir before you remove it and be sure no debris fall in the reservoir. Do not keep the reservoir open for longer than necessary to add brake fluid.

Use only clutch fluid that meets Mahindra specifications. Refer to the 'Lubricant and Capacities' section.

### NOTICE

*Draining or changing of clutch fluid should always be done by an Authorized Mahindra Dealer.*

#### 13.5.8 Checking/Topping Power Steering Fluid

Check the power steering fluid level at the defined service intervals. Refer to Maintenance Chart for details.

The fluid level should be checked if a leak is suspected, abnormal noises are apparent, and/or the system is not functioning as anticipated. Coordinate inspection efforts through an Authorized Mahindra Dealer.

### CAUTION

*Driving a vehicle with power steering fluid below the minimum mark will damage steering system.*

*Use only recommended power steering fluid. Do not use other types of power steering fluids which may damage the power steering system.*

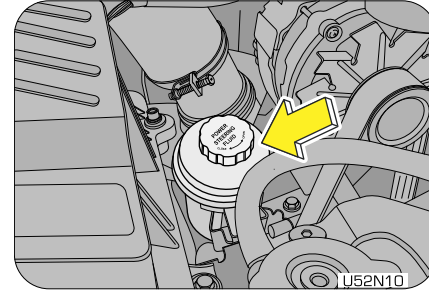

### WARNING

*The fluid level in the reservoir should be checked on a level surface with the engine OFF to prevent injury from moving parts and to ensure accurate fluid level reading.*

Follow the below steps for checking and topping up the power steering fluid;

1. Start the engine and let it run until it reaches normal operating temperature
2. While the engine idles, turn the steering wheel left and right a couple of times
3. Turn the engine OFF
4. Check the power steering fluid level in the reservoir
5. The fluid level should be maintained between the '**MIN**' and '**MAX**' marks on the dipstick, integrated with the cap
6. If the fluid is low, add fluid in small amounts, continuously checking the level until it reaches the correct operating range. Be sure to put the cap back on the reservoir
7. With a clean cloth, wipe any spilled fluid from all surfaces

**NOTICE**

Changing of power steering fluid should always be done by an Authorized Mahindra Dealer.

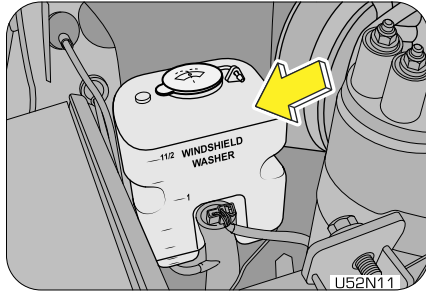
**13.5.9 Windshield Washer Fluid Top-up**

Top up the windshield washer reservoir as and when required. The fluid reservoir is located on the RHS of the engine bay behind the air cleaner assembly. The reservoir supplies washer fluid to front windshield.

**CAUTION**

If you operate your vehicle in temperatures below 4.5°C, use washer fluid with anti-freeze protection. Failure to use washer fluid with anti-freeze protection in cold weather could result in impaired windshield vision and increase the risk of injury or accident.

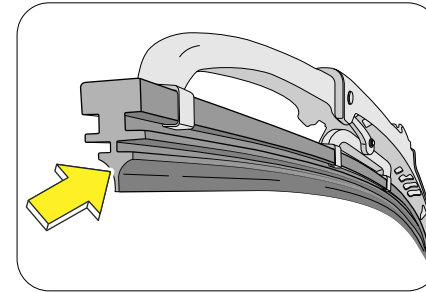
**13.5.10 Checking the Wiper Blades**

Lift the wiper arm from its position. Expose the blade lip for inspection. Clean the wiper blade lips with water applied with a soft sponge. If the wiper blade is not wiping the glass satisfactorily or is worn-out, cut, cracked or bulging get it replaced at an Authorized Mahindra Dealer.

**13.5.11 Changing the Wiper Blade**

1. Lift the arm and position the wiper blade at right angles to the wiper arm
2. Press the retaining clip in the opposite direction, disengage the wiper blade and pull it off the arm



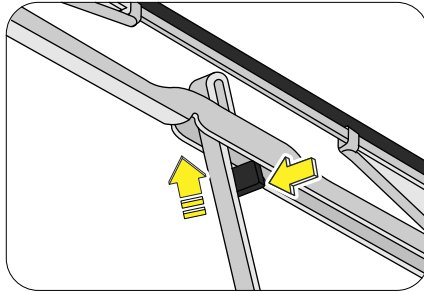

To prevent damage to the windshield, don't let the wiper arm slap down on to it.

3. Hold the end of the rubber and pull until the tabs are free of the metal support
4. Carefully insert the new blade rubber. Then install the blade assembly in the reverse order of removal

### 13.5.12 Fuel Filter Bleeding/Priming

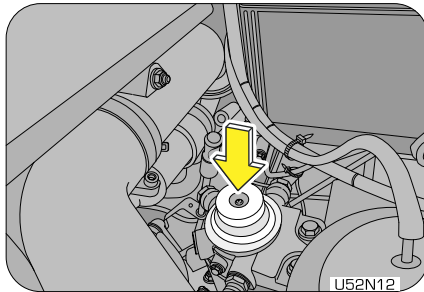

When the fuel level in the fuel tank falls very low, air may enter the fuel lines which leads to the engine not starting or abrupt switching OFF.

The air has to be removed from the fuel pump by bleeding and priming the fuel pump. The fuel pump is located next to the battery in the engine bay. Unscrew the drain nut below the pump by 1–2 turns and observe fuel flow. If there is no fuel flow or intermittent flow, close the drain nut and pump the fuel filter (top face) repeatedly using your palm. Again check for fuel flow by unscrewing the drain nut. Once the flow is normal, tighten the drain nut and try starting the engine. If it fails, drain/pump few more times and retry. If the engine still does not start, contact your nearest Authorized Mahindra Dealer for assistance.

### 13.6 Headlamp Bulb Replacement



*The head lamp bulb can be replaced without removing the head lamp assembly from the vehicle.*

To replace the head lamp bulb;

- Ensure ignition is switched OFF
- Remove rear dust cover from the head lamp
- Remove the bulb assembly with connector from the head lamp by unlocking the wire clamp

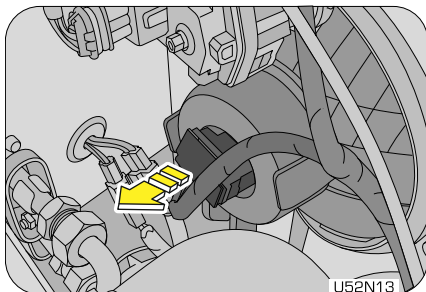

- Detach the bulb assembly from the wiring connector near to the head lamp

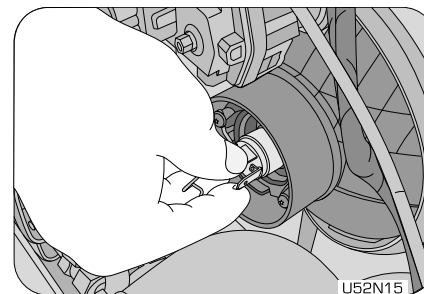
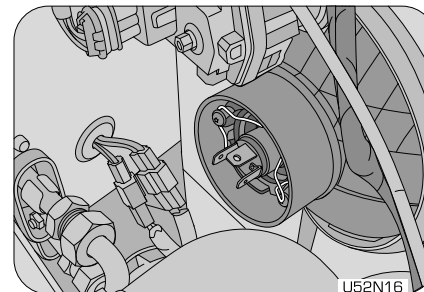
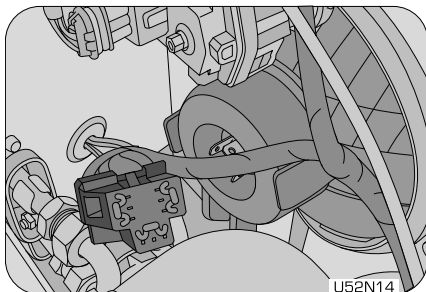

- Insert the connector into the new bulb [of the same wattage], and follow the reverse procedure to assemble the bulb assembly in the headlight assembly
- Clamp the bulb assembly by wire clamp properly

**CAUTION**

*Do not touch the new bulb with your fingers. Oil contamination will severely shorten bulb life. If the bulb comes in contact with any oily surface, clean the bulb with rubbing alcohol.*

 **CAUTION**

*To avoid burning yourself, do not replace the light bulbs when they are hot. Halogen bulbs have pressurized gas inside and are to be handled with special care. Mishandling it may cause the bulb to burst or shatter. Hold the bulb with its metal/plastic holder/base and do not touch the glass part with bare hands.*

*Using bulbs with units of higher output capacity/wattage is illegal and may damage your vehicle's electrical system.*

*Replacement bulbs must meet the specification of originally fitted bulbs.*

## 13.7 Maintenance - Inside the Vehicle

### 13.7.1 Lights

Make sure the headlights, stop lights, tail lights, turn signal lights and other lights are all working. Check headlight aim.

### 13.7.2 Warning Messages and Lamps

Check all warning lamps appearing in the instrument cluster and DDAS. Refer to the relevant sections in this manual for further details.

### 13.7.3 Seats

Check that all seat controls such as seat adjusters, seat back recliner, etc. operate smoothly and that all latches lock securely in any position. Check that the head restraints move up and down smoothly and that the locks hold securely in any latched position.

### 13.7.4 Seat Belts

Check that the seat belt system such as buckles, retractors and anchors operate properly and smoothly. Make sure the belt webbing is not cut, frayed, worn or damaged.

### 13.7.5 Accelerator Pedal

Check the pedal for smooth operation, uneven pedal effort or stickiness. Check the foot well and remove obstructions if any.

### 13.7.6 Brake Pedal

Check the pedal for smooth operation and proper clearance. Check the foot well and remove obstructions if any.

## 13.8 Maintenance-Outside the Vehicle

The following checks should be carried out from time to time, unless otherwise specified.

### 13.8.1 Lamps

Check and ensure proper functioning of all exterior lamps.

### 13.8.2 Fluid Leaks

Check the engine compartment and the underbody of the vehicle for any leaks. If you smell fuel vapor or notice any leak, have the cause found and corrected immediately.

### 13.8.3 Doors and Engine Hood

Check all doors and latches including the tailgate for proper functioning. Make sure the engine hood secondary latch secures the hood from opening when the primary latch is released.

### 13.7.4 Tire Inflation Pressure

Check the tire pressure with a pressure gauge every week.



## 13.9 Battery

Your vehicle is equipped with a Mahindra genuine battery. For longer, trouble-free operation, keep the top of the battery clean and dry. Also, make certain the battery cables are always tightly fastened to the battery terminals.

If you see any corrosion on the battery or terminals, remove the cables from the terminals and clean with a wire brush. To prevent corrosion, apply petroleum jelly to the battery terminals. Tighten loose terminals and hold down clamp nuts only enough to keep the battery firmly in place. Tightening excessively may damage the battery terminals.

### 13.9.1 For Best Battery Service

- Keep the battery securely mounted
- Keep the battery top clean and dry
- Keep the terminals and connections clean, tight and coated with petroleum jelly or terminal grease
- Rinse any spilled electrolyte from the battery immediately with a solution of water and baking soda



*Do not disconnect battery terminals while the engine is running. This will adversely affect all electronic controllers.*



*While removing the battery, always disconnect the negative terminal first. And while installing the battery, ensure the negative terminal is connected last.*

It is recommended that the negative battery cable terminal be disconnected from the battery if you plan to store your vehicle for an extended period of time. This will minimize the discharge of your battery during storage.



*Battery fluid is a corrosive acid solution; do not allow battery acid to contact eyes, skin or clothing. Don't lean over battery when attaching clamps or allow the clamps to touch each other. If acid splashes in the eyes or on the skin, flush contaminated area immediately with large quantities of water.*

*A battery generates hydrogen gas which is flammable and explosive. Keep any flame or spark away from the vent holes.*

*Keep batteries out of reach of children. Battery posts, terminals and related accessories contain lead and lead components. Wash hands after handling batteries.*

*If the battery has been disconnected or a new battery has been installed, the clock (if equipped) and the preset radio (if equipped) stations must be reset once the battery is reconnected.*

*The replacement battery must meet the specification of the originally fitted battery.*

### 13.9.2 Battery Charge Indicator - Amaron (if equipped)

A battery charge indicator is provided for Amaron batteries to view the charge status at a glance. Green indicates the battery is okay, and light blue indicates battery needs recharge or technical assistance from Amaron.



### 13.9.3 Battery Charge Indicator - Exide (if equipped)

A battery charge indicator is provided for Exide batteries to view the charge status at a glance.

Three charge indicators are provided which give the following information;

- **GREEN** —OK (Battery condition good)
- **WHITE** — Needs charging
- **RED** —Add distilled water



### 13.9.4 Checking the Electrolyte Level

Check the electrolyte level and specific gravity at intervals of three months. Check all the six cells for proper electrolyte levels. If the level is below the lower marker, add distilled water until the level reaches the upper marker.

Adding distilled water;

- Remove the vent plugs
- Add distilled water to all the cells that require the fluid and secure the plugs properly

## 13.10 Appearance Care and Protection

### 13.10.1 Washing the Exterior

- Wash your vehicle regularly with cool or lukewarm water and a neutral pH soap
- Never use strong household detergents or soap, such as dish washing or laundry liquid. These products can discolor and spot painted surfaces



- Never wash a vehicle that is 'hot to the touch' or during exposure to strong, direct sunlight
- Always use a clean sponge or car wash mitt with plenty of water for best results
- Dry the vehicle with a chamois or soft terry cloth towel in order to eliminate water spotting
- It is especially important to wash the vehicle regularly during the winter months, as dirt and road salt are difficult to remove and cause damage to the vehicle
- Immediately remove items such as gasoline, diesel fuel, bird droppings and insect deposits; they can cause damage to the vehicle's paint work and trim over time

### 13.10.2 Engine Compartment



*Do not wash the engine or engine compartment with pressurized water.*

### 13.10.3 Exterior Chrome

- Wash the vehicle first, using cool or lukewarm water and a neutral pH shampoo
- Use the custom bright metal cleaners, available at your Authorized Mahindra Dealer. Apply the product as you would wax to clean chrome parts; allow the cleaner to dry for a few minutes, and then wipe off the haze with a clean, dry rag
- Never use abrasive materials such as steel wool or plastic pads as they can leave scratches on the chrome surface
- After polishing the chrome parts, you can also apply a coating of Premium Liquid Wax, available at your Authorized Mahindra Dealer, or an equivalent quality product to help protect from environmental effects

### 13.10.4 Paint Chips

- Mahindra dealers have the exact touch-up paint to match your vehicle's color
- Take your vehicle to an Authorized Mahindra Dealer for paint touch-up or paint repairs
- Remove particles such as bird droppings, tree sap, insect deposits, tar spots, road salt and industrial fallout before repairing paint chips
- Always read the instructions before using the products

### 13.10.5 Aluminium Wheels And Wheel Covers (if equipped)

Aluminum wheels and wheel covers are coated with a clear coat of paint finish. In order to maintain their shine;

- Clean weekly with wheel and tire cleaner, which is available at your Authorized Mahindra Dealer. Heavy dirt and brake dust accumulation may require agitation with a sponge. Rinse thoroughly with a strong stream of water
- Never apply any cleaning chemicals to hot or warm wheel rims or covers
- Do not use hydrofluoric acid-based or high caustic-based wheel cleaners, steel wool, fuels or strong household detergents

### 13.10.6 Plastic (Non-painted) Exterior Parts

Use only approved products to clean plastic parts. These products are available with your authorized dealer. You can use these cleaners;

- For routine cleaning of plastic parts
- For tar or grease spots
- For plastic head lamp lenses



### 13.10.7 Windows and Wiper Blades

The front/rear windshield, side windows and the wiper blades should be cleaned regularly. If the wipers do not wipe properly, substances on the vehicle's glass or the wiper blades may be the cause. These may include hot wax treatments used by commercial car washes, water repellent coatings, tree sap, or other organic contamination; these contaminants may cause squeaking or chatter noise from the blades, and streaking and smearing of the windshield.

To clean these items follow these tips;

- The windshield, rear windows and side windows may be cleaned with a non-abrasive cleaner such as Clear Spray Glass Cleaner, available at your Authorized Mahindra Dealer.
- The wiper blades can be cleaned with alcohol or Premium Windshield Washer Concentrate, available at your Authorized Mahindra Dealer. This washer fluid contains a special solution in addition to alcohol which helps remove the hot wax deposited on the wiper blade and windshield. Be sure to replace wiper blades when they appear worn or do not function properly.
- Do not use abrasives, as they may cause scratches.
- Do not use fuel, kerosene, or paint thinner to clean any glass parts.

If you cannot remove those streaks after cleaning with the glass cleaner or if the wipers chatter and move in a jerky motion, clean the outer surface of the windshield and the wiper blades using a sponge or soft cloth with a neutral detergent or mild-abrasive cleaning solution. After cleaning, rinse the windshield and wiper blades with clean water. The windshield is clean if beads do not form when you rinse the windshield with water.

Do not use sharp objects, such as a razor blade, to remove decals, as it may cause damage to the glass or rear windshield heater grid lines (if equipped).

### 13.10.8 Instrument Panel/Interior Trim and Cluster Lens



*Do not use chemical solvents or strong detergents when cleaning the steering wheel or instrument panel.*

Clean the instrument panel, interior trim areas and cluster lens with a clean and damp white cotton cloth, then with a clean and dry white cotton cloth; you may also use Dash and Vinyl Cleaner on the instrument panel and interior trim areas.

- Avoid cleaners or polishes that increase the gloss of the upper portion of the instrument panel. The dull finish in this area helps protect the driver from undesirable windshield reflection
- Do not use household or glass cleaners as these may damage the finish of the instrument panel, interior trim and cluster lens

If a staining liquid like coffee/juice has been spilled on the instrument panel or on the interior trim surfaces, clean as follows;

- Wipe up spilled liquid using a clean white cotton cloth
- Apply Vinyl Cleaner to the wiped area and spread around evenly
- Apply cleaner to a clean white cotton cloth and press the cloth onto the soiled area and allow this to set in at room temperature for 30 minutes
- Remove the soaked cloth, and if it is not soiled badly, use this cloth to clean the area with a rubbing motion for 60 seconds
- Following this, wipe area dry with a clean white cotton cloth

### 13.10.9 Interior Maintenance

For fabric, carpets, cloth seats, safety belts and seats:

- Remove dust and loose dirt with a vacuum cleaner



- Remove light stains and soil with carpet and upholstery cleaner
- If grease or tar is present on the material, spot-clean the area first with a stain remover
- Do not use household cleaning products or glass cleaners, which can stain and discolor the fabric and affect the flame retardant abilities of the seat materials
- Do not use cleaning solvents, bleach or dye on the vehicle's safety belts, as these actions may weaken the belt webbing.

#### 13.10.10 Leather Seats (where applicable)

Your leather seating surfaces have a clear, protective coating over the leather.

- To clean, use a soft cloth with a leather and vinyl cleaner. Dry the area with a soft cloth
- To help maintain its resiliency and color, use the leather care kit, available from an Authorized Mahindra Dealer
- Do not use household cleaning products, alcohol solutions, solvents or cleaners intended for rubber, vinyl and plastics, or oil/petroleum-based leather conditioners. These products may cause premature wearing of the clear, protective coating

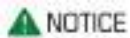

*In some instances, a color or dye transfer can occur when wet clothing comes in contact with leather upholstery. If this occurs, clean the leather immediately to avoid permanent staining.*

#### 13.10.11 Underbody

Flush the complete underside of your vehicle frequently. Keep body and door drain holes free from packed dirt. You can also use an anti-corrosion spray for the underbody to avoid rusting and corrosion especially for vehicles in coastal places.

### 13.11 Air Conditioning System Maintenance

Your vehicle's air-conditioning is a sealed system. Any major maintenance, such as recharging should be done by a qualified technician. However, you can do a few things by yourself to make sure the air conditioning works efficiently.

Run the air-conditioning system at least once a week, even during the cold weather months. Run it for at least ten minutes with the engine running at normal operating temperature. This circulates the lubricating oil contained in the refrigerant.



*Whenever you get the air-conditioning system serviced, make sure the service facility uses a refrigerant recycling system. This system captures the refrigerant for re-use. Releasing the refrigerant into the atmosphere may cause damage to the environment.*

### 13.12 Vehicle Storage

If you are leaving your vehicle for more than 2 weeks you may want to take stopping to protect your battery. Disconnect the negative cable from the battery. Anytime you store your vehicle, or keep it out of service (i.e. vacation) for two weeks or more, run the air conditioning system at idle for about five minutes in the fresh air mode and high blower speed setting. This will ensure adequate system lubrication to minimize the possibility of compressor damage when the system is started again.

It is recommended storing the vehicle in a covered, clean, dry, well leveled, ventilated and closed place.

### 13.13 Winter Care

#### 13.13.1 Dealing With Ice

Make sure you have window ice scrapers and de-icers for the locks. When you're stuck, having a small shovel is useful to dig out of the snow. The weight of a bag of





sand in the trunk will give added traction in rear-wheel drive vehicles and can be used to sprinkle on the snow and ice to gain better traction. And don't forget personal protection such as a warm coat, hat, gloves and a blanket, in case you get stuck in a storm.

### 13.13.2 Keep Enough Fuel in the Tank

Never let the fuel level in the tank drop below the half-full mark. A sudden storm with unexpected heavy rains could leave you stranded for hours. Having adequate fuel supply will allow you to idle the engine from time to time to keep warm.

#### Do not;

- Tap the ice on the window to crack it or chip it for a good place to start scraping. You could end up cracking more than the ice and end up with a cracked or shattered windshield/ window
- Pour warm or hot water on the windshield to melt ice. This will crack your windshield

### 13.13.3 During Winter Storage

Start the engine occasionally, here are a few pointers to keep in mind;

- Run it in a well ventilated area. Carbon monoxide can build up quickly
- Run for a minimum of 20 minutes to allow the engine to come up to the normal operating temperature. This will allow the oil to circulate and will also open up the thermostat so that your radiator anti-freeze circulates as well
- Start up the air conditioner and/or heater and run both for 10 minutes or so. Again, circulating fluids is essential for good life of the system
- If your vehicle has power steering, you may want to turn the wheels a few times to keep the fluids flowing

### 13.13.4 Exterior

Wash and wax your car to provide an extra layer of protection to your paint.

### 13.13.5 Vinyl and Rubber

Use a good conditioner on all vinyl and rubber parts to prevent from drying out.

### 13.13.6 Interior

Clean the glass, shampoo the carpets, dig in between the seats to see what's there, clean the upholstery in all nooks and corners.

### 13.13.7 Engine

Check all hoses and wires to make sure everything is in good condition and replace any that need to be. The last thing to do is to make sure the internal components of the engine remain lubricated and don't corrode.



*If the engine is being started after a very long period of non-use, warm up the engine at an idle speed for 2-3 minutes before driving the vehicle.*

## 13.14 Maintenance Service Information

While it goes without saying that your vehicle is designed to give you the best performance, you are advised to maintain it as per Instructions given in the Owner's Handbook.

- You are entitled to three labour free services by any of our Dealers/ Service Centres as per the following schedule:

All consumable such as oil/oil filter, fuel filter and service maintenance items if changed, are charged. Labour charges are free.



- All the free inspection services should be availed of, preferably within the vehicle's warranty period.
- Free/Paid services can be availed of at any of our Authorised Dealers/ Service Centres spread across India, irrespective of the Dealer who has sold you the vehicle.
- For claiming benefits under warranty, it is necessary to avail Free Services and Paid Services given by Dealers/Service Centres at the specified kms.
- The nature of various jobs carried out by Dealers/Service Centres during services are clearly indicated in the Owner's Handbook and Service Coupon Booklet.

The owner should retain records/documents that proper maintenance has been performed as prescribed.

<i>1st free service to be availed</i>	<i>5000 kms</i>
<i>2nd free service to be availed</i>	<i>10000 kms</i>
<i>3rd free service to be availed</i>	<i>20000 kms</i>

### 13.14.1 Scheduled Maintenance

The scheduled maintenance jobs listed in the 'Scheduled Maintenance Chart' are those required to be carried out at regular predetermined intervals.

To make sure that your vehicle runs efficiently all the time, follow the maintenance schedule. The service interval for the scheduled maintenance is determined by the odometer reading. Take your vehicle to an Authorized Mahindra Service Station only. Trained technicians and genuine Mahindra parts at Mahindra Authorized service stations are best for your vehicle. They will perform all the scheduled maintenance jobs reliably and economically. Inadequate, incomplete and insufficient servicing may result in problems.



**13.14.2 Maintenance Schedule Chart**

Description	Change Interval	Free Services			Paid Services							
		5000	10000	20000	30000	40000	50000	60000	70000	80000	90000	100000
<i>A = Adjust as Necessary I = Inspect and correct. Replace if worn out or faulty R = Replace L = Lubricate C = Clean</i>												
<b>ENGINE</b>												
Engine Oil <sup>1</sup>	Replace at 5,000, 20,000 kms, then every 20,000 kms	R	I	R	I	R	I	R	I	R	I	R
Engine Oil Filter	Replace at 5,000, 20,000 kms, then every 20,000 kms	R		R		R		R		R		R
Auto Tensioner	Replace every 1,00,000 kms							I		I		R
Accessory Drive Belts	Replace every 1,00,000 kms							I		I		R
Coolant <sup>3</sup>	Replace at 60,000 kms, then every 80,000 kms	I	I	I	I	I	I	R	I	I	I	I
<b>AIR, FUEL AND EXHAUST</b>												
Air Filter Element <sup>5</sup>	Replace every 40,000 kms					R				R		
Fuel Filter Element	Replace every 20,000 kms			R		R		R		R		R
Fuel Tank & Stainer										C		
Water In Fuel Filter <sup>0</sup>		I	I		I		I		I		I	
<b>TRANSMISSION</b>												
Manual Transmission Oil <sup>2</sup>	Replace at 10,000 kms, 1,00,000 kms then every 1,00,000 kms		R									R
Transfer Case Oil - 4WD	Replace every 60,000 kms							R				
<b>AXLES, WHEELS AND TYRES</b>												
Differential Oil <sup>2</sup> (Rear)	Replace at 10,000 kms, 60,000 KM, then every 60,000 kms		R					R				



Description	Change Interval	Free Services			Paid Services							
		5000	10000	20000	30000	40000	50000	60000	70000	80000	90000	100000
<i>A = Adjust as Necessary I = Inspect and correct. Replace if worn out or faulty R = Replace L = Lubricate C = Clean</i>												
Differential Oil (Front) – 4WD Only	Replace at 10,000 kms, 60,000 KM, then every 60,000 kms		R						R			
Locking Hub – 4WD	Lubricate every 40,000 kms					L				L		
Front & Rear Wheel Bearings	Lubricate every 50,000 kms						L					L
Tyre Rotation *	Inspect every 10,000 kms		I	I	I	I	I	I	I	I	I	I
<b>BRAKES &amp; CLUTCH</b>												
LSPV Setting		I				I				I		
Brake + Clutch Fluid - Level And Leak <sup>a</sup>	Replace every 40,000 kms or every 1 year		I	I	I	R	I	I	I	R	I	I
Brake Pads / Calipers	Inspect every 20,000 kms			I		I		I		I		I
Brake Liners / Drums	Inspect every 20,000 kms			I		I		I		I		I
Parking Brake		I		I		I		I		I		I
<b>SUSPENSION</b>												
Front Suspension Bolt Torque		I	I	I		I		I		I		I
Suspension Bushes (Shackle & Pivot)	Inspect every 20,000 kms			I		I		I		I		I
<b>STEERING</b>												
Power Steering Fluid - Level And Leak	Inspect every 10,000 kms		I	I	I	I	I	I	I	I	I	I
Power Steering Belt	Replace every 1,00,000 kms	I		I		I		I		I		R
Wheel Alignment*	Inspect if abnormal conditions are noticed or at 40,000 kms, whichever is earlier											
<b>ELECTRICALS</b>												
Battery Electrolyte Level	Inspect every service	I	I	I	I	I	I	I	I	I	I	I
Battery Electrolyte Specific Gravity	Inspect every service	I	I	I	I	I	I	I	I	I	I	I



Description	Change Interval	Free Services			Paid Services							
		5000	10000	20000	30000	40000	50000	60000	70000	80000	90000	100000
<i>A = Adjust as Necessary I = Inspect and correct. Replace if worn out or faulty R = Replace L = Lubricate C = Clean</i>												
All Lights, Horns, Wipers And Washers	Inspect every service	I	I	I	I	I	I	I	I	I	I	I
Head Light Aiming	Inspect at 5,000 kms	I										
<b>FINAL INSPECTION</b>												
Tyre Pressure	Inspect every service	I	I	I	I	I	I	I	I	I	I	I
All Nuts And Bolts For Tightness		I	I	I		I		I		I		I
Exhaust Pipe Mountings and Damage / Leakage		I	I	I		I		I		I		I
Road Test		I	I	I	I	I	I	I	I	I	I	I
*On chargeable basis;					<sup>5</sup> - Under extreme operating conditions replace air filter every 35,000 kms							
<sup>1</sup> Change as per the kms or 1 year whichever earlier					<sup>B</sup> - Change brake and clutch fluid every 40,000 km or every 1 yr whichever earlier; Subsequent change every 80,000 km							
<sup>2</sup> Change as per the kms or 2 years whichever earlier					<sup>D</sup> Check and clean as per kms or when indicator glows							
<sup>3</sup> Change as per the kms or 3 years whichever earlier												
<i>A = Adjust as Necessary, I = Inspect and correct.; Replace if worn out or faulty; R = Replace ;L = Lubricate ;C = Clean</i>												

# Alphabetical Index

4WD System (if equipped)..... 10-6

## A

AC ON/OFF ..... 9-2  
Air Conditioning System Maintenance ..... 13-19  
Air-Conditioning System ..... 9-1  
Aluminium Wheels And Wheel Covers ..... 13-17  
Appearance Care and Protection ..... 13-16

## B

Battery ..... 13-15  
Battery Charge Indicator - Amaran ..... 13-15  
Battery Charge Indicator - Exide ..... 13-16  
Blower Speed Control ..... 9-3  
Bulb Specification ..... 2-6

## C

Calculating Fuel Efficiency ..... 10-10  
Changing the Wiper Blade ..... 13-11  
Checking the Electrolyte Level ..... 13-16  
Checking the Wiper Blades ..... 13-11  
Checking/Topping Brake Fluid ..... 13-9  
Checking/Topping Clutch Fluid ..... 13-9  
Checking/Topping Engine Coolant Level ..... 13-8  
Checking/Topping Power Steering Fluid ..... 13-10  
Checking/Topping the Engine Oil ..... 13-7  
Chemicals and Additives ..... 13-3  
Courtesy Lamp ..... 7-5

## D

Dealing With Ice ..... 13-19  
Dimensions ..... 2-2  
Driver Seat ..... 5-1  
Driving Through Water ..... 10-5  
Driving Your Vehicle ..... 10-4

## E

Engine Compartment ..... 13-17  
Engine Coolant Temperature Gauge ..... 7-10  
Engine Oil ..... 13-7  
Engine Oil Consumption ..... 13-7  
Exterior Chrome ..... 13-17  
Exterior Lamps ..... 7-2

## F

Fastening/Unfastening the Seat Belt ..... 5-3  
Features and Control ..... 7-1  
Flat Tire ..... 2-6  
Fluid Leaks ..... 13-7  
Front Doors ..... 6-1  
Front Overview ..... 3-1  
Fuel ..... 10-9  
Fuel Filter Bleeding/Priming ..... 13-12  
Fuel Gauge ..... 7-9  
Fuses and Relays ..... 2-3

## G

Gear Shifting ..... 10-3  
General Driving Precautions ..... 10-4  
General Maintenance ..... 13-6  
General Owners Information ..... 13-1

General Safety Information and Instructions ..... 1-2  
General Warnings and Instructions ..... 5-1  
Get the most from your service and maintenance visits ..... 13-3  
Glove Box ..... 7-6

## H

Hazard Warning Lamp ..... 7-5, 12-1  
Head Lamp ..... 7-3  
Head Lamp Leveling System ..... 7-4  
Head Restraint ..... 5-1  
Horn ..... 7-7

## I

Identifying Components in the Engine Compartment ..... 13-5  
Ignition Switch ..... 10-1  
In the Engine Compartment ..... 13-7  
Inflating Your Tires ..... 11-4  
Instrument Cluster ..... 4-1, 7-8  
Instrument Panel/Interior Trim and Cluster Lens ..... 13-18  
Interior Maintenance ..... 13-18

## J

Jacking ..... 2-8  
Jump Starting ..... 12-3

## K

Keep Enough Fuel in the Tank ..... 13-20

# Alphabetical Index

## L

Lamps OFF .....	7-3
Leather Seats .....	13-19
Life of Tire .....	11-5
Lighting Control Stalk .....	7-2
Limp Home Mode .....	12-5
Locks and Keys .....	6-1
Lubricants and Capacities .....	2-1

## M

Maintenance Interval .....	13-2
Maintenance Schedule Chart .....	13-22
Maintenance Service Information .....	13-20
Maintenance-Inside the Vehicle .....	13-14
Maintenance-Outside the Vehicle .....	13-14
Manual Windows .....	7-1

## N

Need Assistance? .....	13-2
------------------------	------

## O

Oils, Fluids and Flushing .....	13-2
Opening the Hood .....	13-3
Operating Instructions/Precautions .....	10-7
Outside Rear View Mirror (ORVM) .....	7-1

## P

Paint Chips .....	13-17
-------------------	-------

Parking Lamps ON .....	7-3
Plastic (Non-painted) Exterior Parts .....	13-17
Power Outlet .....	7-5
Protect your Warranty .....	13-2

## R

Radial Ply Tires .....	11-4
Radio Frequency ID (RFID) Tag .....	7-14
Rough Road Driving Precautions .....	10-4

## S

Safety Symbols .....	1-1
Safety Tips - Before Starting your Vehicle .....	10-1
Scheduled Maintenance .....	13-21
Seats and Seat Belts .....	5-1
Shifting Procedure .....	10-7
Side Overview .....	3-1
Snow Chains .....	11-5
Speedometer .....	7-9
Starting and Driving the Vehicle .....	10-1
Starting the Engine .....	10-2
Steering and Brakes .....	8-1
Stopping the Engine .....	10-6
Suggestions for Obtaining Service for your Vehicle .....	13-1

## T

Tailgate .....	6-2
Technical Specifications .....	2-10
Tips for Better Fuel Economy .....	10-10
Tire Pressure .....	11-1, 11-3
Tire Rotation Recommendations .....	11-5
To Owner's of a Mahindra Vehicle .....	1-3
Towing .....	12-6

Towing Equipment .....	12-6
Towing your Vehicle during Emergency .....	12-6
Tread Wear Indicators (TWI) .....	11-4
Trip meter, Odometer, Clock, Mode and Reset Button .....	7-10
Turn Signals .....	7-2

## U

Underbody .....	13-19
Utility Holders .....	7-6

## V

Vehicle Does not Start - Checks .....	12-1
Vehicle Identification Number .....	2-12
Vehicle Overheating .....	12-2
Vehicle Self Maintenance - General Precautions .....	13-3

## W

Warning Lamps in the Instrument Cluster .....	4-1
Warning Lamps in the Instrument Cluster .....	7-11
Warranty Information .....	13-2
Washing the Exterior .....	13-16
Windows and Wiper Blades .....	13-18
Windshield Washer Fluid Top-up .....	13-11
Windshield Wiper/Wash .....	7-8
Winter Care .....	13-19