

# Owner's Manual



T4, T4+, T6, T6+, T6+ AMT, T8, T8 AMT

---

**Issue Date: August 2015**

**Revision 3: May 2016**

**NOTE:** *Carefully read, understand and follow the instructions provided in this manual, and keep it in a safe place for future reference. If you have any doubt whatsoever regarding the use or care of your vehicle, please visit your Mahindra Dealer for assistance or advice.*

*This Owner's Manual should be considered as an integral part of the vehicle and should remain with the vehicle.*

**Mahindra**

---

MAHINDRA & MAHINDRA LTD., GATEWAY BUILDING, APOLLO BUNDER, MUMBAI - 400 039

*[www.mahindra.com](http://www.mahindra.com)*



# Table of Contents

1	INTRODUCTION AND SAFETY PRECAUTIONS .....	1-1	Instrument Panel Overview .....	3-3
	Introduction .....	1-1	4 INSTRUMENT CLUSTER OVERVIEW.....	4-1
	Safety Symbols .....	1-1	Instrument Cluster .....	4-1
	General Safety Information and Instructions .....	1-2	Warning Lamps Overview.....	4-3
	To Owner's of a Mahindra Vehicle.....	1-4	Warning Lamps .....	4-4
	Audio/Infotainment Manual.....	1-6	5 SEATS AND SEAT BELTS .....	5-1
2	GENERAL .....	2-1	Driver seat.....	5-1
	Feature Matrix.....	2-1	Head Restraint.....	5-4
	Lubricants and Capacities .....	2-4	Second Row Bench Seat.....	5-5
	Dimensions.....	2-6	Third Row Seats.....	5-5
	Bulb Specification .....	2-7	General Warnings and Instructions- Seat Belts.....	5-6
	Fuses and Relays .....	2-7	Fastening the Seat Belt.....	5-9
	Flat Tire .....	2-12	Child Restraint System (CRS) .....	5-11
	Jack Points.....	2-15	6 SUPPLEMENTAL RESTRAINT SYSTEM (SRS) (if	
	Technical Specifications.....	2-19	equipped) .....	6-1
	Vehicle Identification Number (VIN).....	2-21	Airbags.....	6-1
3	VEHICLE OVERVIEW .....	3-1	Introduction.....	6-1
	Front Overview.....	3-1	7 LOCKS AND KEYS .....	7-1
	Rear Overview.....	3-2	Locks and Keys.....	7-1

# Table of Contents

Central Locking System.....	7-3	Warning Lamps Overview.....	8-29
Remote Keyless Entry (RKE) System .....	7-5	Warning Lamps in the Instrument Cluster .....	8-30
Engine Immobilizer System.....	7-10	Voice Messaging System(VMS) (If equipped).....	8-34
<b>8 FEATURES AND CONTROL.....</b>	<b>8-1</b>	Mike(If equipped).....	8-34
Power Windows.....	8-1	Reverse Parking Assist System (RPAS)(If equipped) .....	8-35
Butterfly Window (Rear Quarter Window).....	8-2	Brake Energy Regeneration Technology(If equipped) .....	8-40
Outside Rear View Mirror (ORVM).....	8-3	Micro Hybrid Technology (Engine Stop/Start System, ESS)(If equipped) .....	8-42
Interior Mirror .....	8-4	Radio Frequency ID (RFID) Tag.....	8-47
Exterior Lamps .....	8-5	<b>9 STEERING AND BRAKES.....</b>	<b>9-1</b>
Follow-Me Home (FMH) RKE.....	8-11	Steering.....	9-1
Follow-Me Home (FMH) Non RKE.....	8-12	Tilt Steering .....	9-2
Lead Me to Vehicle (LMV) (RKE).....	8-12	Steering Controls - Audio Control System (if equipped) .....	9-2
Interior Lamps.....	8-13	Brakes .....	9-4
Power Outlet .....	8-14	Anti-Lock Brake System (ABS) (if equipped).....	9-6
Windshield Wipers.....	8-16		
Utility Holders .....	8-20		
Horn.....	8-22		
Instrument Cluster.....	8-23		
Instrument Cluster Gauges.....	8-24		

# Table of Contents

## 10 HEATING, VENTILATION AND AIR-CONDITIONING SYSTEM

(HVAC).....	10-1
HVAC Overview.....	10-2
Center/Side Vents.....	10-3
HVAC Controls .....	10-3
Air Distribution Control.....	10-4
Blower Speed Control.....	10-5
Temperature Control.....	10-5
Air Intake Mode Control.....	10-6
Air-Conditioner ON.....	10-6
HVAC Air Filter (Cabin Air Filter).....	10-7
Rapid Cabin Cooling.....	10-8
Rapid Cabin Heating.....	10-8
Defogging/De-misting and Defrosting .....	10-9
11 STARTING AND DRIVING THE VEHICLE.....	11-1
Safety Tips - Before Starting your Vehicle.....	11-1
Ignition Switch.....	11-2
Pedals.....	11-3
Starting the Engine.....	11-3

Stopping the Engine .....	11-5
Manual Transmission (If Equipped).....	11-5
Automated Manual Transmission (AMT) (If Equipped) .....	11-8
Driving Your Vehicle .....	11-15
Fuel.....	11-19
Tips for Better Fuel Economy.....	11-20

12 WHEELS AND TYRES .....	12-1
Tyre Information.....	12-1
Tyre Rating .....	12-1
Tyre Label (Vehicle Placard).....	12-2
Tire Pressure.....	12-3
Tyre Rotation Recommendations .....	12-6
13 EMERGENCIES.....	13-1
Hazard Warning Lamp.....	13-1
Vehicle Does not Start - Checks.....	13-1
Vehicle Overheating.....	13-2
Jump Starting.....	13-3
Towing .....	13-7

# Table of Contents

Limp Home Mode .....	13-9
14 MAINTENANCE .....	14-1
General Owners Information.....	14-1
Opening/Closing the Hood.....	14-4
Identifying Components in the Engine	
Compartment.....	14-6
General Maintenance .....	14-7
In the Engine Compartment.....	14-8
Maintenance - Inside the Vehicle .....	14-14
Maintenance - Outside the Vehicle .....	14-14
Battery.....	14-15
Appearance Care and Protection.....	14-16
Air Conditioning System Maintenance.....	14-20
Vehicle Storage .....	14-20
Winter Care .....	14-21
Bulb Replacement .....	14-22
Scheduled Maintenance.....	14-23
Maintenance Schedule Chart.....	14-24



# 1 INTRODUCTION AND SAFETY PRECAUTIONS

## 1.1 Introduction

Dear Customer,

Congratulations on purchasing your Mahindra TUV300. Your vehicle is designed to provide years of safe and dependable service, as long as it is used and maintained in accordance with the instructions provided in this manual.

All persons who will use and/or maintain this vehicle should read, understand and follow all the warnings and instructions provided in this manual. This Owner's Manual should be considered as an integral part of the vehicle and should remain with the vehicle. However, nothing in this manual, and none of the safety devices installed in the vehicle, are a substitute for careful operation and common sense. Always make sure that your vehicle is in optimum working condition, and take note of the road and weather conditions in which you are using your vehicle.

If you have any questions regarding the proper use or maintenance of your vehicle ; please call your Authorized Mahindra Dealer. The list of dealers can be found in the Dealer Directory Supplement.

Alternatively you can contact us at,

- 1800-209-6006 (Toll free)
- [customercare@mahindra.com](mailto:customercare@mahindra.com)

We extend our best wishes for safe and pleasurable motoring.

Sincerely,

MAHINDRA & MAHINDRA LTD.

### Servicing and Summary Data

- For any issues concerning the vehicle and for any spare parts, contact only the Authorized Mahindra network
- We recommend you should always use genuine Mahindra spare parts when performing repairs on the vehicle
- We suggest that you record the vehicle data in the Warranty Information & Maintenance Guide for future references

## 1.2 Safety Symbols

Carefully read, understand and follow the safety symbols/ instructions given in this manual.

### Legend of the Symbols

To emphasize information and procedures regarding safety, use, maintenance, etc., the following symbols are used throughout the manual.



*DANGER indicates an imminently hazardous situation which, if not avoided, will result in death or serious injury.*





### WARNING

*WARNING indicates a potentially hazardous situation which, if not avoided, could result in death or serious injury.*

### CAUTION

*CAUTION indicates a potentially hazardous situation which, if not avoided, may result in minor or moderate injury and/or property damage.*

### NOTICE

*NOTICE indicates important information relevant to the vehicle, the vehicle's use or to sections of this manual to which particular attention must be paid for optimum use of the vehicle.*

If you see this symbol, it indicates “no”, “do not,” “do not do this,” or “never”.



## 1.3 General Safety Information and Instructions

### WARNING

*Failure to follow the warnings and instructions provided in this manual could result in failure of the vehicle, an accident and/or serious personal injury.*

1. Carefully read, understand and follow the warnings and instructions given in this manual. This manual is an essential part of the product. Keep it in the vehicles glove box for future reference
2. Spare bulb and first aid kit are placed in the glove box of the vehicle. Ensure that they are not taken out of the vehicle at any point of time.
3. Please note that throughout this manual, reference is made that “an accident” could occur. An accident could cause you or a bystander to sustain personal injury, or result in property damage
4. Never use a mobile phone or any device with headphone while driving. This may take your focus off the road and lead to accidents
5. Please be advised that many service and repair tasks require specialized knowledge, tools and experience. General mechanical aptitude may not be sufficient to properly service or repair your vehicle. If you have any doubt whatsoever regarding the ability to properly service or repair your vehicle,



- please contact your Authorized Mahindra Dealer or a qualified technician
6. Inspect the seat belt system periodically, checking for cuts, frays or wear in the seat belt webbing, or loose buckles, retractors, anchors or other loose parts. Damaged parts must be replaced immediately
  7. Always start and operate the engine in a well-ventilated area. If in an enclosed area, vent the exhaust to the outside. Do not modify or tamper with the exhaust system
  8. Examine tyres for excessive tread wear and uneven wear patterns. Check for stones, nails, glass, or other objects lodged in the tread and check sidewalls for any cuts, cracks, or other signs of wear. Replace as necessary
  9. Always maintain the safety labels affixed to your vehicle in a good legible condition
  10. All signal lamps, buzzers, shields, guards and other protective safety devices must always remain in place and in good, proper working condition
  11. The life span of Mahindra products depend on many factors. Improper use, abuse or harsh use in general may compromise the integrity of the vehicle and significantly reduce its life span. The vehicle is also subject to wear over a period of time. Please have your vehicle regularly inspected by an Authorized Mahindra Dealer or a qualified mechanic. If the inspection reveals any damage or excessive wear, immediately replace or have the component serviced
  12. We recommend that you use only genuine parts supplied by Mahindra. The use of non-Mahindra parts will not be covered by warranty
  13. Never crawl under or be in close proximity to the vehicle when it is lifted off the ground (by a jack), unless the vehicle is properly supported with jack stands, wheel chocks and other appropriate safety devices
  14. Never attempt any repairs or adjustments to any component while the vehicle is in motion. Always switch off the engine, and wait for the engine to come to a complete stop before performing any repairs or adjustments
  15. The vehicle identification plates are the only legal identification reference, hence it is necessary to keep them in good condition. Never modify data on the plates or remove them. The customer is responsible for any possible tampering with the plates, which will immediately void the warranty
  16. Do not attempt sharp turns, abrupt maneuvers, or other unsafe driving actions that can cause loss of vehicle control. When the vehicle is fully loaded, drive at a slow speed, especially when turning. Note that the centre of gravity of the vehicle changes when the vehicle is fully loaded , and also if luggage is mounted on the roof carrier



## 1.4 To Owner's of a Mahindra Vehicle

When first driving the vehicle after long periods of non-use, you may experience a temporary drive disturbance. This is a characteristic of the tyres and should be no reason for concern. The condition should correct itself within 5-15 kms. of driving. If the disturbance persists, have the tyres checked by an Authorized Mahindra Dealer.

### Driving and Alcohol

Your driving ability can be seriously impaired by alcohol even if the blood alcohol level is far below the legal minimum. Drunken driving is one of the most frequent causes of accidents.



*Never drink and drive. Drinking and driving will lead to an accident resulting in serious personal injury.*

### Driving and Drugs/Medication

Your driving ability can be seriously impaired through the use of prescription or non-prescription drugs or medication (even cough syrup). If you are taking any sort of drug or medication, be sure that it will not affect your driving ability.

### Mobile Phones Warning

Use of electrical devices such as mobile phones, computers, portable radios or other by the driver while driving is dangerous. In exceptional condition if use of a mobile phone is necessary despite

this warning, use a handsfree system to ensure that the hands are free to drive the vehicle. Even handsfree do not ensure that due to distraction a accident will not happen

Please comply with the legal regulations concerning the use of communication equipment in vehicles in your country.

### Driving Long Distances

When you are driving over long distances, follow these tips so that you have a safe journey;

- Lack of sleep or fatigue will impact your ability to drive safely.
- Exercise your eyes by shifting the focus of your eyes to different parts of the road.
- Use stimulating beverages such as coffee or tea.
- Relax and stay calm.
- Take breaks at regular intervals

### Protecting Our Environment

All of us should play our part in protecting our environment. Judicious vehicle usage and ensuring hazardous waste disposal (including cleaning and lubrication fluids) are important steps towards this initiative.

Mahindra vehicles confirm to existing emission norms (standards). Adhering to the periodical maintenance schedule and using



Mahindra genuine parts will help retain emission performance of the vehicle and is a pre-requisite for emissions warranty coverage.

### Servicing

If you have any questions concerning the proper use or maintenance of your vehicle, please call your Authorized Mahindra Dealer. A list of dealers can be found in the Dealer Directory Supplement or on the Internet.

Alternatively you can contact us on **1800-209-6006** / **customercare@mahindra.com**.

### Running-in

Driving smoothly during first 1000 kms. will help to prevent abnormal and premature system wear. Proper running in will improve the life of drivetrain and vehicle components.

A new engine may consume more oil during the first 1000 kms. of running. This should be considered as a normal part of break-in and not interpreted as any problem with the engine.

### Mahindra Genuine Parts

Mahindra uses high quality parts for building the vehicles.

In the event that any parts need replacement, we recommend that you use only Mahindra genuine parts.

Non-Mahindra parts may harm vehicle performance and will not be covered by your Mahindra warranty.

To avoid counterfeit parts and to protect our brand image, Mahindra genuine parts are packed in a branded carton. Look for the "Mahindra Genuine Parts" logo.



### WARNING

*Any unauthorized modifications or alterations to this vehicle or failure to use appropriate specification and quality spare parts could seriously affect vehicle road worthiness and safety leading to an accident, resulting in serious injury*

### Mahindra Genuine Accessories

A wide selection of quality accessories is available through your authorized Mahindra dealership. These accessories have been specifically engineered to allow you to personalize your vehicle to suit your requirements and compliment its style and aerodynamic appearance.

Each accessory is made from high quality materials and meets Mahindra's rigid engineering and safety specifications. Every Mahindra accessory installed according to the Mahindra installation provisions comes with the respective accessory warranty.

Consult your Mahindra authorized dealer for detailed information about accessories available for your specific model variant.

 **NOTICE**

*For maximum vehicle performance and safety considerations always keep the following information in mind.*

- *When adding accessories, equipment, passengers and luggage to your vehicle, do not exceed the total weight capacity of the vehicle or of the front and rear axle. Consult Mahindra authorized dealer for specific weight information.*
- *Bull bars and nudge guards are not recommended for variants with an airbag.*
- *Accessories causing any change in vehicle specifications like wheel rims, bull bars, etc., may affect the performance of safety systems.*
- *Mobile communication systems such as two way radios, telephones and theft alarms that are equipped with radio transmitters and installed in your vehicle should comply with the local regulations and should be installed only by a your Authorized Mahindra Dealer*

**Vehicle Safety**

When leaving your vehicle unoccupied;

- Always remove the ignition key when you park the vehicle
- Close all the windows completely and lock all the doors

- Do not leave any valuables in your vehicle. If you must leave something in your vehicle, hide them and securely lock all the doors

**1.5 Audio/Infotainment Manual**

Please refer the Audio/Infotainment user manual available in the vehicle for details regarding;

- Audio/Infotainment functions
- Bluetooth functions
- Hands free usage



## 2 GENERAL

### 2.1 Feature Matrix

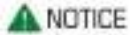

*In view of our policy of continuously improving our products, we reserve the right to alter specifications, designs or features without prior notice and without any liability.*

We recommend you contact the nearest Authorised Mahindra Dealer for the latest features applicable to your vehicle.

Feature	T4	T4+	T6	T6+	T6+ AMT	T8	T8 AMT
<b>Technology</b>							
Micro Hybrid Technology (Engine Start/Stop)						✓	
Automated Manual Transmission (AMT)- "autoSHIFT"					✓		✓
Intellipark						✓	✓
Digital Immobiliser	✓	✓	✓	✓	✓	✓	✓
Voice Messaging System (VMS)			✓	✓	✓	✓	✓
Remote Lock & Keyless Entry (RKE)			✓	✓	✓	✓	✓
Infotainment System With Display Screen, 2 DIN Music System, Bluetooth, USB, AUX			✓	✓	✓	✓	✓
Driver Information System (DIS)						✓	✓
Static Bending Head Lamps						✓	✓
<b>Safety</b>							
Airbag Driver side		✓		✓	✓	✓	✓
Airbag Co-driver side		✓		✓	✓	✓	✓
Anti-Lock Braking System (ABS) with EBD		✓	✓	✓	✓	✓	✓



Feature	T4	T4+	T6	T6+	T6+ AMT	T8	T8 AMT
Collapsible Steering Column	✓	✓	✓	✓	✓	✓	✓
Tubeless Tyres	✓	✓	✓	✓	✓	✓	✓
<b>Style</b>							
Wheels	Steel Rims	Steel Rims	Wheel Caps	Wheel Caps	Wheel Caps	Alloys	Alloys
Roof-top Ski Racks			✓	✓	✓	✓	✓
Front Fog Lamps						✓	✓
Side and Rear Foot Step			✓	✓	✓	✓	✓
<b>Comfort &amp; Convenience</b>							
Tiltable Steering	✓	✓	✓	✓	✓	✓	✓
Individual Armrest for Driver & Co-driver Seats						✓	✓
Driver Seat Height Adjust						✓	✓
Lumbar Support (Driver & Co-Driver Seat)						✓	✓
Second Row Seat Fold						✓	✓
Electric ORVM						✓	✓
Power Steering	✓	✓	✓	✓	✓	✓	✓
Power Windows	✓	✓	✓	✓	✓	✓	✓
Central Locking	✓	✓	✓	✓	✓	✓	✓
Mobile Charging Point	Front Row only		Front & Second Row				
Rear Wipe & Wash			✓	✓	✓	✓	✓
Rear Defogger			✓	✓	✓	✓	✓
Lead-me-to-Vehicle Head lamps —LMV [RKE]						✓	✓
Follow-me-Home Head lamps						✓	✓
Lighting of the glove box			✓	✓	✓	✓	✓



Feature	T4	T4+	T6	T6+	T6+ AMT	T8	T8 AMT
Steering Mounted Audio & Phone Controls						✓	✓
Eco Mode	✓	✓	✓	✓		✓	
Storage Tray Below Driver's Seat						✓	✓
"mHawk <sup>100th</sup>						✓	✓
"mHawk <sup>80th</sup>	✓	✓	✓	✓	✓	✓	





## 2.2 Lubricants and Capacities

System	Lubricant	Capacity (liters)	Specification	Remarks
<b>ENGINE - "mHawk<sup>80 &amp; 100"</sup></b>	MAHINDRA "MAXIMILE FEO V2" NEW GENERATION GENUINE ENGINE FLUID	6.0	Special Engine Fluid	Always use "MAXIMILE FEO V2" new generation Mahindra genuine engine oil. This is specially developed for your engine's optimum performance and fuel efficiency  In extreme cases of emergency and non-availability of above oil, we suggest Engine Oil meeting minimum API CH-4 SAE 15W-40 specification can be used and replaced at 6000 km. This alternate oil or other Brand will not provide equivalent performance of above Genuine oil
<b>TRANSMISSION</b>	MAHINDRA "MAXIMILE SYNTEC F2" NEW GENERATION GENUINE TRANSMISSION FLUID	2.0	Special Manual Transmission Fluid	Other Transmission Oils meeting API GL-4 SAE 80W-90 Specifications, Drain Interval should change to 20000km. Other Brand may not provide equivalent performance of recommended oil
<b>AMT HYDRAULIC OIL</b>	AMT HYDROMATIC (0701HAD00030N)	0.7	Special Hydraulic Fluid	Special super clean oil recommended for AMT hydraulic unit. No other oil recommended or to be used. Alternate oil usage may harm the performance and cause unit failure
<b>REAR AXLE</b>	MAHINDRA "MAXIMILE ELITE" NEW GENERATION GENUINE DIFFERENTIAL FLUID	2.0	Special Differential Fluid	Other Axle Oils meeting API GL-5 SAE 80W-90 Specifications, Drain Interval should change to 20000km. Other Brand may not provide equivalent performance of recommended oil
<b>POWER STEERING</b>	SHELL "SPIRAX S3 ATF MD3" Part No. (1102EAA00470N)	0.8	Alternately CALTEX MAKE "TEXAMATIC 1888" BRAND can be used . NO OTHER BRAND SHOULD BE USED	



<b>BRAKE AND CLUTCH</b>	MAHINDRA "MAXIMILE DOT 4" Genuine Brake fluid	0.9	If Maximile DOT 4 brake fluid is not used and in emergency conditions, use Brake Fluid Meeting SAE J1703 FMVSS NO.116 DOT 4 OR IS 8654 TYPE-2 Specification and change it at 30,000 km or 2 years whichever earlier
<b>ENGINE COOLING</b>	MAHINDRA "MAXIMILE ULTRA COOL" GENUINE LONG LIFE COOLANT (READY TO USE COOLANT. NO NEED TO MIX WATER)	~4.5	Brand Specific. Don't use other coolants / water for top up. In case of emergency, coolant meeting JIS K-2234 specification should be used (30% concentration diluted with distilled water) and coolant change period to be reduced as 30,000 km
<b>RECOMMENDED FUEL</b>	Diesel confirming to Indian standard IS 1460; 2010 BS IV / BS III specification or equivalent.	60	—



## 2.3 Dimensions

### 2.3.1 Front View



### 2.3.2 Rear View



### 2.3.3 Side View



DIMENSION & WEIGHTS	mm
Wheel Base	2680 mm
Overall Length	3995 mm
Overall Width	2079 mm (including outside mirrors)
Overall Height	1839 with ski rack
Track Width (Front)	1520 mm
Track Width (Rear)	1500 mm

*The specifications are for reference only. Subject to change without prior notice*



## 2.4 Bulb Specification

Lamp Bulb	Wattage
Head Lamp	H4 (12V 55/60W)
Park lamp	W5W (12V 5W)
Turn lamp	P21W (12V 21W)
Static Bending lamp	H1 (12V 55W)
Front Fog lamp	H8 (12V 35W)
Side Turn Signal lamp	W5W (12V 5W)
Tail / Stop lamp	P21/5W (12V 21/5W)
Rear Turn lamp	PY21W (12V 21W)
Reverse lamp	P21W (12V 21W)
Rear Fog lamp	P21W (12V 21W)
Registration Plate lamp	W5W (12V 5W)
Roof lamp	C5W (12V 10W)

## 2.5 Fuses and Relays

A fuse is the most common electric protection device. The fuse is placed in an electrical circuit, so that when current flow exceeds the rating of the circuit/fuse, it blows off. The element in the fuse melts, opening the circuit and preventing other components of the circuit from being damaged by the over current. The size of the metal fuse element determines the rating. Once a fuse blows off, it must be replaced with a new one of the same rating.

Switch the ignition and all electrical equipment OFF before touching or attempting to change a fuse.



*Replacement fuse must be with the same rating as the one you have removed.*



*You can identify a blown fuse by a break in the filament. All fuses except high current fuses are press fit.*

*Never touch fuses with bare hands. Always use the fuse puller to remove and refit the fuses.*

*Be careful while removing the relay, to avoid damage to relay terminal – do not shake or apply excessive force .*



There are 3 fuse boxes in the vehicle;

- Battery Mounted Fuse Box
- Engine Compartment Fuse Box
- Instrument Panel Fuse Box

## 2.5.1 Engine Compartment Fuse Box

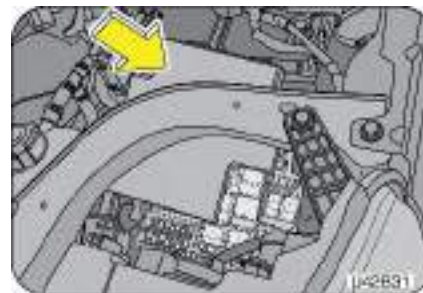

The engine compartment fuse box is located adjacent to vehicle battery. Follow the below steps to remove the fuse cover;

- Slightly press/nudge the fuse cover towards the Head lamp side and remove the front snap lock



- Further, push top cover towards battery side and remove/pull the cover completely



Fuse puller is available in this fuse box location.

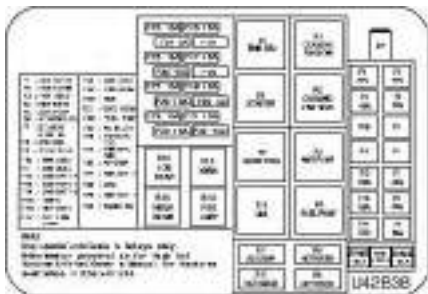

Fuse No	Fuse Rating	Circuit
F1	40A	ABS Motor
F2	30A	EMS Loads
F3	—	—
F4	—	—
F5	40A	AMT Pump
F6	40A	Starter solenoid
F7	40A	EC Mini Fuse B+
F8	25A	ABS Solenoid
F9	40A	Glow plug
F10	—	—
F11	—	—

Fuse No	Fuse Rating	Circuit
F12	60A	Battery Cable 2
F13	60A	Battery Cable 1
F14	60A	Battery Cable 3
F15	15A	Horn
F16	—	—
F17	15A	Front fog lamp
F18	—	—
F19	15A	Low beam
F20	5A	BMS
F21	15A	High beam
F22	15A	EKP
F23	10A	AC Relay
F24	5A	ESS/ WIF/ TPS
F25	15A	EGR/ PBA/ FMU
F26	10A	AC Compressor
F27	10A	EMS Battery 2
F28	10A	HFM
F29	10A	EMS Battery 1
F30	15A	Brake switch

Relay No	Circuit
R1	Cooling Fan Low
R2	Cooling Fan High
R3	AMT Pump
R4	EMS ECU
R5	GNS — Non ESS
R6	—
R7	—



Relay No	Circuit
R8	Starter Relay
R9	Glow plug
R10	GNS—ESS
R11	AC Compressor
R12	Fuel pump

## 2.5.2 Instrument Panel Fuse Box

- Pull the Fuse box cover below the switch bank, outward to access the instrument panel fuse box



*Spare fuses are available in this fuse box location.*

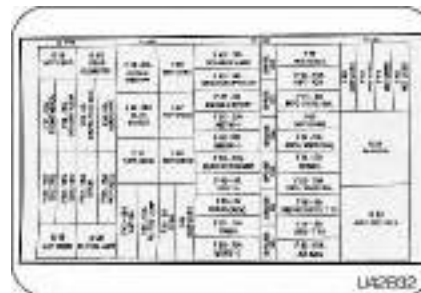

Fuse No	Fuse Rating	Circuit
F31	15A	Front Wiper
F32	10A	Rear Wiper/WashInfotainment/IC/FATC
F33	5A	MBFM/ FATC ACC
F34	5A	Audio ACC
F35	15A	Cigar LTR2



Fuse No	Fuse Rating	Circuit
F36	15A	Cigar LTR1
F37	10A	ORVM
F38	—	—
F39	40A	Power window
F40	40A	Blower motor
F41	—	—
F42	10A	AMT B+
F43	10A	Rear fog lamp
F34	5A	Instrument cluster B+
F45	—	—
F46	—	—
F47	—	—
F48	—	—
F49	10A	Interior lamp
F50	15A	Infotainment/ HVAC/ FATC B+
F51	5A	Immobilizer B+
F52	20A	MBFM —1
F53	20A	MBFM —3
F54	15A	Rear Defogger
F55	5A	Key IN
F56	5A	Diagnostics
F57	10A	Park lamp
F58	20A	MBFM —2
F59	—	—
F60	15A	AMT —IGN
F61	5A	Infotainment/ FATC IGN
F62	—	—
F63	5A	EMS/ Immo IGN

Fuse No	Fuse Rating	Circuit
F64	5A	Crank
F65	10A	Reverse / RPAS IGN
F66	5A	MBFM / FATC / T15
F67	5A	ABS —T15
F68	10A	Airbag
F69	—	—
F70	—	—
F71	—	—
F72	—	—

Relay No	Circuit
R15	—
R18	De-mister Relay
R19	—
R20	Rear Foglamp
R21	Blower
R22	AC cut off

### 2.5.3 Battery Mounted Fuse Box

The battery mounted fuse box is connected to the positive terminal of the battery. Functionality of battery mounted fuse box is to provide short circuit protection to alternator, power supply to main engine compartment fuse box & electric cooling fan.



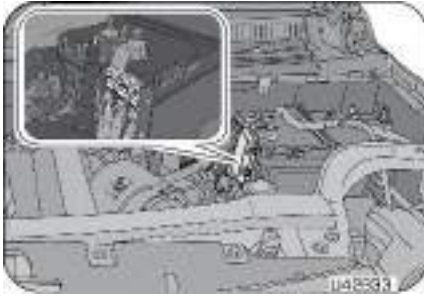

Battery mounted fuse box consist of following fuses:

- Main charging fuse – 125A (Pink colour)
- Bus bar fuse - 80A (White colour)
- Cooling fan fuse – 60A (Yellow colour)

## 2.6 Flat Tire

Reduce your speed gradually, keeping a straight line. Move cautiously off the road to a safe place well away from traffic. Park on a level spot with firm ground. Stop the engine and turn ON your hazard warning flashers.

Firmly apply the parking brake. Have everyone come out of the vehicle on the side away from traffic.

After stopping, use the hazard warning triangle to alert the oncoming traffic of the stopped vehicle



*Never stop your vehicle in a traffic lane to change a tire. Keep driving until you reach a safe location.*

The jack provided along with the vehicle is to be used only for changing a spare tire. It is never to be used to perform any other maintenance or repair on the vehicle.



*Never place any part of your body under any portion of the vehicle when it is supported only by the jack. You could be crushed by the vehicle if it falls off a jack. Keep by-stander's away from the vehicle.*

Find level, solid ground that is clear of oncoming traffic. If you cannot find a safe place to stop, it is better to drive on a flat tire and damage the rim than it is to risk being hit by oncoming traffic.

After changing a flat tire, never store the tire or other equipment in the passenger compartment of the vehicle. This loose equipment could strike an occupant in the event of a sudden stop or collision. Store all of these items in the proper place.

**The following sections outline the procedure for changing a flat tire;**



## 2.6.1 Jack/Wheel Spanner

The jack and tool bag is placed under the third row seat.



Remove the velcro placed around the Tool bag .

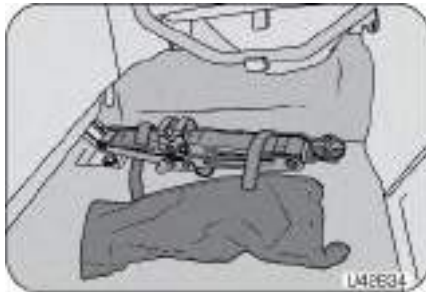

Jack is held in place by a wing type bolt. Remove the wing bolt and move the jack towards tail gate slightly to remove it from its position.

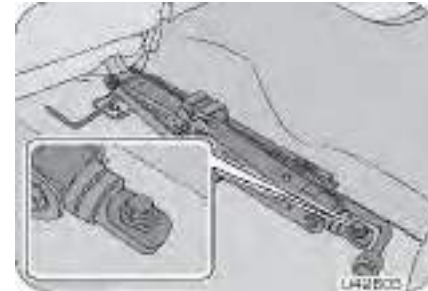

Wheel spanner, jack handle Tow hook and Tools are placed in the tool bag and fastened using Velcro.



## 2.6.2 Spare Wheel Removal

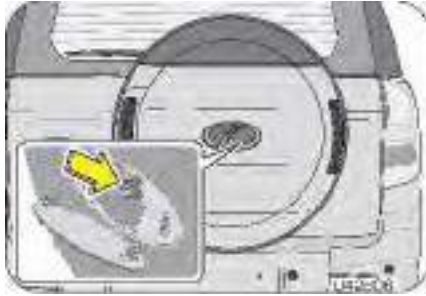

The spare wheel is mounted on the back door at the rear end of the vehicle. It is held in place by a securing nuts underneath the Mahindra badge.

- Wrap the tip of a screw driver with cloth, insert it at the bottom edge of the Mahindra badge on the spare wheel cover (if equipped) and pry the badge away from the Cover
- Loosen and remove the securing nut counter clockwise with a wheel spanner
- Hold the spare wheel cover with both hands and pull outwards to remove
- Loosen the remaining spare wheel nuts counter clockwise with a wheel spanner
- Slowly support and lower the spare wheel

### CAUTION

*A anti-theft lock system is provided for the spare wheel as shown. Any small lock can be used to disable the securing nut from being removed.*



## 2.6.3 Wheel Nut Loosening

Wrap the tip of a screw driver with cloth, insert it near the lugs of the wheel cap (if equipped) and pry the cap away from the wheel.

### CAUTION

*Do not try to pry off the wheel cap by hand alone. Take due care in handling the wheel cap to avoid unexpected personal injury.*



Always loosen the wheel nuts before raising the vehicle. Turn the wheel nuts counter clockwise to loosen as per the crisscross sequence shown. To get maximum leverage, fit the spanner to the nut so that the handle is on the left side. Grab the spanner near the end of the handle and push down on the handle. Be careful that the spanner does not slip off the nut. Do not remove the nuts, but loosen them by one or two turns.

**CAUTION**

*Do not apply force with your legs (or stand) on the wheel spanner while loosening/tightening the wheel nuts.*

## 2.7 Jack Points

**Front jack up point** - On the chassis long member behind the front wheels.

**Rear jack up point** - On either side of the rear axle.

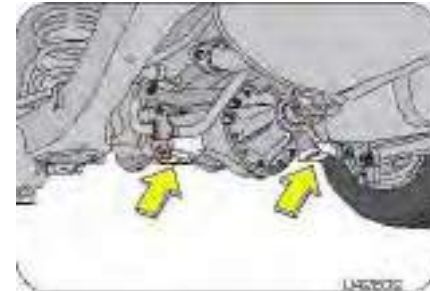
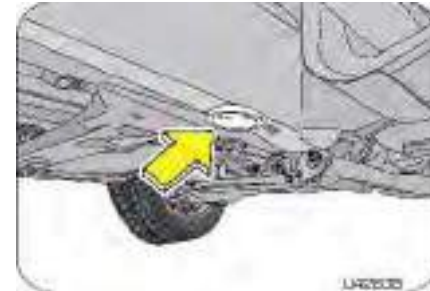



## 2.7.1 Jacking

Position the jack at the correct jacking point. Make sure the jack is positioned on a level and solid ground. Ensure that no one is in the vehicle.

Block the wheel diagonally opposing the flat tyre to keep the vehicle from rolling when it is jacked up. While blocking the wheel, place a wheel block in front of one of the front wheels or behind one of the rear wheels.



A	Flat Tyre	B	Chock Blocks
---	-----------	---	--------------

To raise the vehicle, insert the jack handle end along with the extension into the jack and turn it clockwise with the jack handle. As the jack touches the vehicle and begins to lift, check that it is properly positioned. Raise it high enough so that the spare tire can be installed. Remember that you will need more ground clearance

when putting the inflated spare tire than when removing the flat tire.



*Make sure to locate the jack properly in the jacking point. Raising the vehicle with an improperly positioned jack will damage the underbody of the vehicle and may allow the vehicle to fall off the jack and cause personal injury.*

- Use the jack only for lifting the vehicle during wheel changing
- Do not raise the jack with any person inside the vehicle
- When raising the vehicle, do not place any objects on top of or underneath the jack
- Raise the vehicle only high enough to remove and change the wheel
- The usable extended height of jack is up to the yellow line/mark. Do not raise the jack above the yellow line.
- Follow jacking instructions
- Do not start or run the engine while your vehicle is supported by the jack



*Never get under the vehicle when the vehicle is supported by the jack alone.*



Remove the wheel nuts. Remove the flat tyre straight off and then place it aside. Roll the spare wheel into position and align the holes of the disc with the bolts. Lift the wheel and hand tighten the top wheel nut. Wiggle the wheel and press it back over the other bolts.

Re-install the wheel nuts with the tapered end inward and tighten by hand. Press the wheel inward and tighten the wheel nuts further.

Before lowering the wheel hand tighten the nuts in diagonal sequence so that wheel is flush against the hub/drum

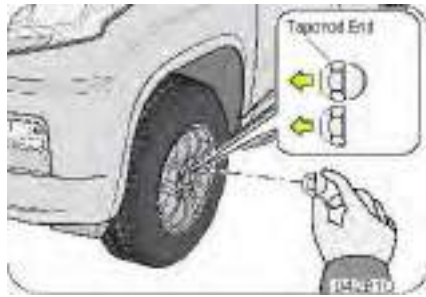

**WARNING**

*Never use oil or grease on the bolts or nuts. Doing so may lead to over tightening of the nuts, wheel nut spanner slip, damage the bolts and also may cause personal injuries. Also, nuts may loosen and the wheels may fall off, which could cause a serious accident. If there is oil or grease on any bolt or nut, clean before installing wheel nuts.*

Lower the vehicle completely and tighten the diagonally opposite wheel nuts using the wheel nut spanner. Turn the jack handle extension anti clockwise using the jack handle to lower the vehicle, making sure the handle remains firmly fitted onto the jack handle extension. Make sure the wheel spanner is securely engaged over the nut. Tighten each nut a little at a time in the diagonally opposite order as shown. Repeat the process until all the nuts are tight. Do not use any other tools or any additional leverage other than your hands, such as a hammer, pipe or your foot.



**NOTICE**

*Firmly tighten the wheel nuts as per the sequence shown in the illustration , two to three times.*

**WARNING**

*Improperly or loosely tightened wheel nuts are dangerous. The wheel can wobble or come off. This can result in loss of vehicle*



*control and cause a serious accident. Always make sure all the wheel nuts are properly/securely tightened to the specified torque.*

*When lowering the vehicle, make sure all portions of your body are clear off the vehicle as it is lowered to the ground. Have the wheel nuts tightened with the torque spanner to 120 Nm, as soon as possible after changing wheels.*

#### WARNING

*If you have rotated, repaired, changed your tyres or changed the wheel rims, retorque the wheel nuts after driving about 1,000 kms [Torque 120 Nm].*

Put the wheel cap (if equipped) into position aligning the nozzle on the wheel to the nozzle clearance on the wheel cover. Tap it firmly on the sides with your hand to snap it into place.

Check the air pressure of the replaced tyre. If the pressure is lower than recommended, drive slowly to the nearest service station and inflate to the correct pressure. If it is too high, adjust it until it is correct. Always reinstall the valve cap after checking or adjusting tyre pressure. If the cap is not replaced, dirt and moisture could get

into the valve core and cause air leakage. If you lose a valve cap, buy another and install it as soon as possible.

#### CAUTION

*Wheel balancing to be done after tyre puncture rework.*

### 2.7.2 Restore the Tools, Jack and Flat Tyre Securely

Restore the tools and jack back to their respective locations. Mount the flat tyre to the back door bracket at the rear of the vehicle. Firmly tighten the securing nuts and put the wheel cover back. Double check to ensure the tyre is snug against the back door of the vehicle.

#### NOTICE

*It is recommended to fix the flat tyre at the nearest tyre shop and swap the spare wheel back. The wheel balance and alignment differ from wheel to wheel which may lead to difference in steering and braking.*



## 2.8 Technical Specifications

Technical Specifications		
	ENGINE - "mHawk <sup>80</sup> "	ENGINE - "mHawk <sup>100</sup> "
Displacement/Cubic Capacity	1493 cc	
Type	4 Stroke Turbocharged Compression Ignition	
Bore x Stroke	83.0 mm X 92.0 mm	
No of Cylinders	3	
Max. Engine Output	62.6 KW @ 3750 rpm	73.5 KW @ 3750 rpm
Max. Engine Output (AMT) "autoSHIFT"	60.4 KW @ 3750 rpm	73.5 KW @ 3750 rpm
Max. Torque (Nm @ rpm)	230 Nm @ 1500 to 2250 rpm	240 Nm @ 1600 to 2800 rpm
<b>CLUTCH</b>		
Type	Single plate Dry Diaphragm Type	
<b>TRANSMISSION</b>		
Type	Manual Synchromesh in all Forward Gears	
No. of Gears	5 Forward, 1 Reverse	
<b>SHIFT MECHANISM</b>		
Type	Manual/Automated	
<b>GEAR RATIOS</b>		
I	3.78 : 1	
II	2.21 : 1	
III	1.42 : 1	





### Technical Specifications

IV	1.00 : 1
V	0.789 : 1
Reverse	3.56 : 1
<b>AXLES</b>	
Front	N/A
Rear	4.3 : 1
<b>WHEELS &amp; TIRES</b>	
Rim	6.5J x 15"
Tires	215/75 R15
<b>STEERING</b>	
Type/Description	Rack & Pinion type , Power assisted - Hydraulic
Turning Circle Radius	5.21 m
<b>SUSPENSION</b>	
Front	Double Wish-Bone with Coil Spring, Stabilizer Bar
Rear	Rigid axle Multi-Link [5 Links] with Coil Spring, Stabilizer Bar
Anti-rollbar	Front and Rear
Shock Absorber	Double Acting Telescopic Hydraulic Shock Absorber
<b>BRAKES</b>	
Service Brake	Hydraulic & Vacuum assisted with optional
Front	Ventilated Disc
Rear	Drum type



### Technical Specifications

Parking Brake	Integral Drum
<b>FUEL</b>	
Fuel Capacity	60 liters
<b>ELECTRICAL SYSTEM</b>	
System Voltage	12V
Battery	65 Ah / 72 Ah / 90 Ah

## 2.9 Vehicle Identification Number (VIN)

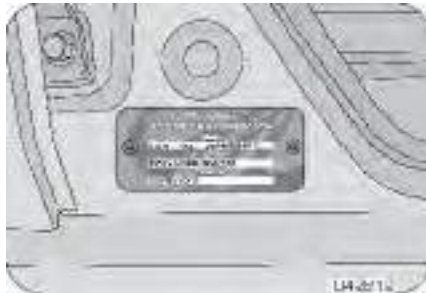

Vehicle Identification Number (VIN) is the legal identity of your vehicle. The vehicle identification number is stamped on the VIN plate riveted on the driver side. It is visible after opening Driver door on the B pillar of the vehicle. The engine number is also stamped on the same plate.





## 3 VEHICLE OVERVIEW

### 3.1 Front Overview

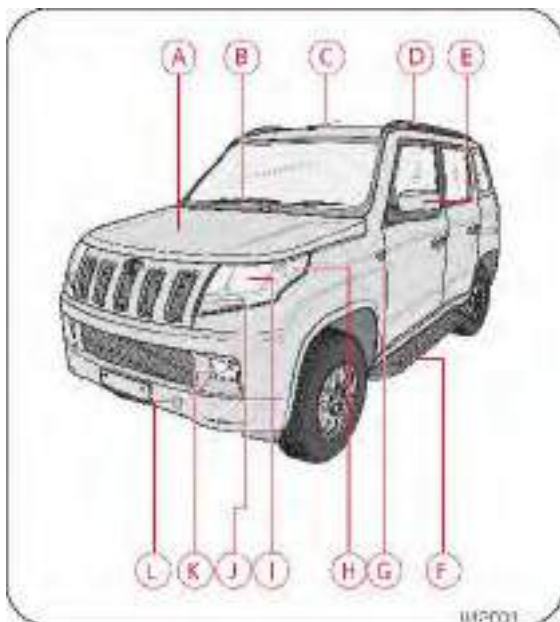

A	Hood
B	Front Windshield Wiper
C	Antenna *
D	Ski Rail*
E	Outside Rear View Mirror
F	Footstep*
G	Side Repeater
H	Static Bending Lamp
I	Front Park Lamp
J	Front Turn Signal Lamp
K	Fog Lamp*
L	Front Tow Hook Mounting provision
M	Head lamp

\* If equipped



### 3.2 Rear Overview

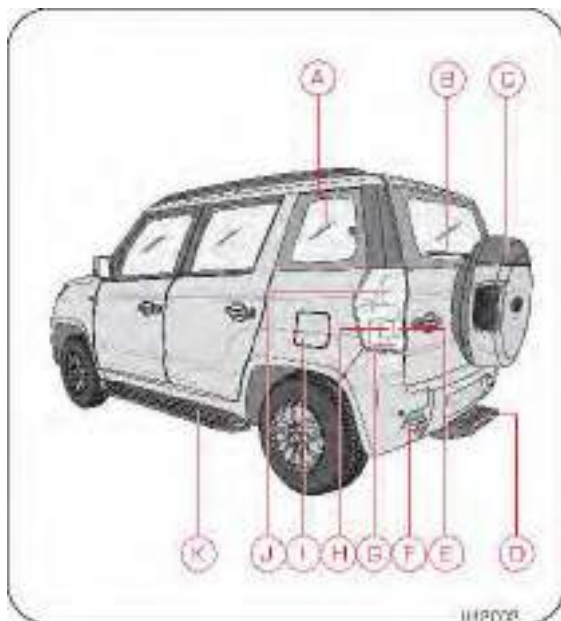

A	Rear Butterfly window
B	High Mounted Stop Lamp
C	Rear Wiper*
D	Spare wheel
E	Rear Footstep*
F	Reversing Lamp
G	Reflector
H	Rear Tow hook mounting provision
I	Reversing Sensor*
J	Rear Turn signal Lamp
K	Fuel Lid
L	Rear Park Lamp/Brake Lamp
M	Side Footstep*
<i>* If equipped</i>	



### 3.3 Instrument Panel Overview

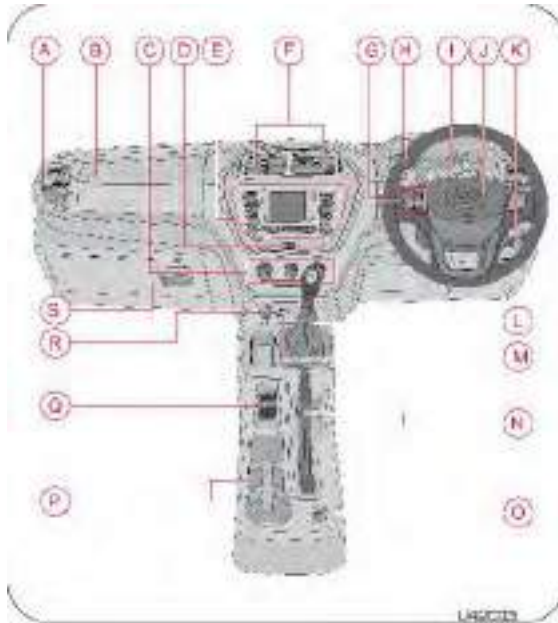

A	Side Vents	K	Headlamp Levelling/ ESS/ ORVM/ PowerECO switches
B	Passenger Airbag*	L	Transmission Gear Lever
C	HVAC Controls	M	AUX/USB Ports
D	Hazard Warning switch	N	Parking Brake
E	Infotainment Screen*	O	12V Power Outlet -Rear
F	Centre Vents	P	Can/Bottle holder
G	Steering controls -Audio*	Q	Power Window switches
H	Steering wheel	R	12V Power Outlet - Front
I	Instrument Cluster	S	Glove Box
J	Horn Pad/Driver Airbag		

\* if equipped





## 4 INSTRUMENT CLUSTER OVERVIEW

### 4.1 Instrument Cluster



A	Tachometer / RPM Gauge	F	Odometer
B	Warning/Tell tale Lamps	G	Gear Display
C	Speedometer	H	Temperature Gauge





D	Mode Button	I	Trip A, B, AC Meter & DTE
E	Fuel Gauge	J	Set Button



## 4.2 Warning Lamps Overview



Airbag Warning Lamp	Park/Stop Lamp	Low Fuel Warning Lamp	Water in Fuel Warning Lamp
Left Turn Indicator	Check Engine Lamp	Park/Low Brake Fluid Lamp	Parking Lamp
Right Turn Indicator	Door Ajar Lamp	Security Lamp	ABS Warning Lamp
Headlamp High Beam	High Temperature Lamp	Battery Charge Lamp	Front Fog Lamp
Malfunction Lamp (DRL)	Low Oil Pressure Lamp	Seat Belt Warning Lamp	ECO Lamp







To know more about warning & telltale lamps, download the handy “Mahindra TUV300” app from Google playstore or Appstore U42D03









### 4.3 Warning Lamps

The phenomenon of warning lamps flashing momentarily when ignition is turned ON is called pre-check. This is self check done by the cluster at every ignition ON.

Symbol	Warning Lamp/Tell Tale	Lamp Pre-check	Lamp Status	Action/Remarks
	Parking Brake ON/Brake Fluid Low Warning Lamp/ EBD Malfunction	No	Continuously ON	<p>Either one of below conditions:-</p> <ol style="list-style-type: none"> <li>1) Park brake might be engaged</li> <li>2) Brake fluid level might be low</li> <li>3) EBD Malfunction detected</li> </ol> <p>Contact Authorized Mahindra Dealer immediately for assistance if the lamp is not turning OFF even after checking the above conditions</p>
	Left Turn Indicators	No	Slow or Fast Blinking	<p>Indicates left turn lamp is blinking</p> <p><b>Slow Blinking:</b> Normal operation</p> <p><b>Fast Blinking:</b> One / more left turn lamp bulb has fused. Have the bulb replaced</p>
	Water in Fuel Filter Warning Lamp	Yes	Continuously ON	<p>Indicates water in fuel filter. Drain the water from filter or contact an Authorized Mahindra Dealer for assistance</p>







Symbol	Warning Lamp/Tell Tale	Lamp Pre-check	Lamp Status	Action/Remarks
	Security Lamp	No	Slow or Fast Blinking	<b>Slow Blinking:</b> Vehicle armed and Immobilizer system active <b>Fast Blinking:</b> Once the ignition is turned OFF, security lamp will blink at fast rate frequency indicating vehicle is secured against unauthorized start of engine
	Check Engine Lamp	For about 3 sec	Continuously ON or Blinking	There is a potential malfunction in the engine system, contact an Authorized Mahindra Dealer immediately
	High Coolant Temperature Warning Lamp	No	Continuously ON or Blinking	Engine temperature very high. Contact an Authorized Mahindra Dealer immediately
	Right Turn Indicators	No	Slow or Fast Blinking	Indicates right turn lamp is blinking <b>Slow Blinking:</b> Normal operation <b>Fast Blinking:</b> One / more turn signal lamp bulb has fused. Have the bulb replaced
	Head Lamp High Beam Indicator	No	Continuously ON	Indicates head lamp high beam is ON
	ABS Warning Lamp	For about 3 sec.	Continuously ON	Indicates malfunction of the ABS system. Contact an Authorized Mahindra Dealer immediately



Symbol	Warning Lamp/Tell Tale	Lamp Pre-check	Lamp Status	Action/Remarks
	Airbag Warning Lamp	For about 4.5 sec.	Continuously ON	Indicates malfunction of the airbag system. Contact an Authorized Mahindra Dealer immediately
	Door Ajar Warning Lamp	No	Continuously ON	Indicates one or more doors are open
	Front Fog Lamp Indicator	No	Continuously ON	Indicates front fog lamp is ON
	Seat Belt Warning Lamp	No	Continuously ON	Indicates driver seat belt not fastened. If tell tale is not turning OFF even after fastening the driver seat belt, contact an Authorized Mahindra Dealer for assistance
	Low Fuel Warning Lamp	No	Continuously ON	The fuel level in the fuel tank is low. Re-fuel immediately to avoid empty tank
	Start/Stop Lamp	For about 3 sec.	Continuously ON or Blinking	<b>Continuously ON:</b> Engine is in auto stop mode <b>Blinking:</b> Stop/Start is about to stop the engine <b>Fast Blinking:</b> Stop/Start is inhibited due to unhealthy battery conditions
	Malfunction Lamp (OBD)	Continuously ON till Engine Starts	Continuously ON	There is a potential malfunction related to emission control system, contact an Authorized Mahindra Dealer immediately



Symbol	Warning Lamp/Tell Tale	Lamp Pre-check	Lamp Status	Action/Remarks
	Battery Charging Warning Lamp	Continuously ON till Engine Starts	Continuously ON	Indicates malfunction in the charging system. Contact an Authorized Mahindra Dealer for assistance
	Low Engine Oil Pressure Warning Lamp	Continuously ON till Engine Starts	Continuously ON	Indicates engine oil pressure is low. Check oil level and top-up or contact an Authorized Mahindra Dealer for assistance
	Glow Plug Indicator	For about 2 seconds	Continuously ON	Indicates a malfunction in the starting system. Contact an Authorized Mahindra Dealer immediately
	AMT warning lamp	For about 3 sec.	Continuously ON	Indicates malfunction of the AMT system. Contact an Authorized Mahindra Dealer immediately
	ECO Lamp*	No	Continuously ON	Indicates that your vehicle is running in Economy mode. If lamp does not turn ON after pressing ECO switch or If lamp ON without pressing ECO switch, contact an authorized Mahindra dealer immediately





## 5 SEATS AND SEAT BELTS

### 5.1 Driver seat

#### 5.1.1 Sitting in the Correct Position



Follow the tips below for a comfortable and safe journey;

- Sit in an upright position with the base of your spine pressed against the seat back
- Adjust the head restraint as close as possible to the above specified position, with the top of the head restraint even with the top of your head
- Maintain sufficient distance between yourself and the steering wheel. Maintain at least a ten inch (10") distance from the centre of the steering wheel to your chest

- The top curve of the steering wheel should align with your chin for ideal road visibility
- Adjust your seat and seat back angle such that your wrists rest on top of the steering wheel freely
- Ensure your legs are in a bent position while fully depressing the clutch pedal

The seat should be adjusted while still maintaining control of the foot pedals, steering wheel and your view of the instrument panel controls.

#### WARNING

*Never adjust the driver's seat while the vehicle is in motion. The seat may unexpectedly move and cause the driver to unintentionally operate the accelerator or brake, or turn the steering wheel, causing loss of control of the vehicle, an accident or serious personal injury. Adjust the driver's seat only when the vehicle is not in motion.*

*Never put objects under the seats. They may interfere with the seat-lock mechanism or unexpectedly activate the seat position adjusting lever, causing the seat to suddenly move, resulting in loss of control of the vehicle, an accident or serious personal injury.*

*While adjusting the seat, do not put your hands under the seat or near the moving parts. This may lead to injuries.*





### 5.1.2 Front Seat Slide

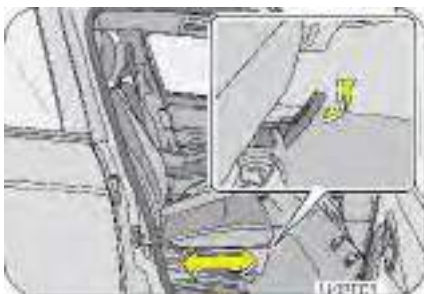

Move the seat forward or backward by lifting the adjustment lever/ towel bar located under the seat front and release once the desired position is reached.

### CAUTION

*While adjusting the seat, make sure the latch engages fully and the seat is locked firmly in the desired position. An unlocked seat may move in a sudden stop or collision, causing injury to the person in that seat. Push and pull on the seat to be sure it is locked.*

### 5.1.3 Front Seat Recline



To adjust the seat back, lift the recline lever located on the outboard side of the seat, lean back and release the lever at the desired position. To return the seat back, lift the lever, lean forward, and release the lever.

**⚠ WARNING**

*The seat belts provide maximum protection in a frontal or rear collision when the occupants are sitting up straight and well back in the seats. If you are reclined, the lap belt may slide past your hips and apply restraint forces directly to the abdomen, or the shoulder strap may contact your neck.*

**⚠ CAUTION**

*When returning an extremely reclined seat back to its upright position, make sure you support the seat back while operating the lever.*

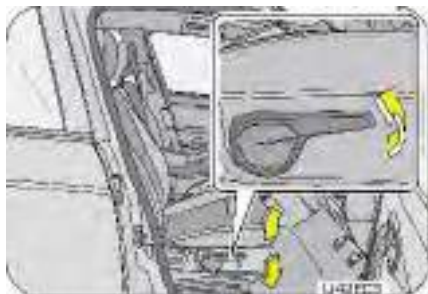
**5.1.4 Driver Seat Height Adjust (if equipped)**

Lift/Push the seat height adjustment lever located on the outboard side of the driver seat to raise/lower the seat. Adjust the seat

height such that you are able to depress the clutch pedal completely.

**⚠ WARNING**

*It is recommended to adjust the seat height only when the vehicle is stationary.*

**5.1.5 Foldable Arm-Rests (if equipped)**

Front seats are provided with individual foldable arm rests.



### 5.1.6 Lumbar Support (if equipped)

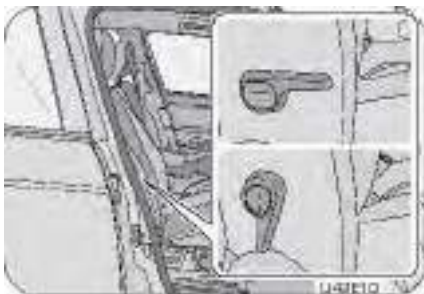

Both the front seats are provided with lumbar support. Turn the lever on the outboard side of the seat back as per requirement to enable/disable lumbar support.

### 5.2 Head Restraint

Your vehicle seats are equipped with head restraints which are vertically adjustable. The purpose of these head restraints is to help limit head motion in the event of a collision.

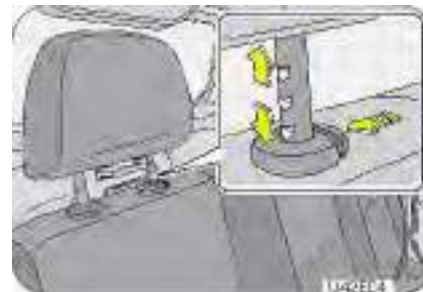

Always align top of the head restraint with the top of your head or as close to it as possible. To raise/lower the head restraint, press the lock tab and pull/push the restraint up/down.

The head restraint can be pulled out completely by depressing the locking button while pulling the restraint out. To put it back, align the head restraint shafts over the holes on the seat top and push the restraint straight down till you hear the lock click.

Keep the seat back as upright as possible so the headrest is behind, not beneath, and almost touching your head.



*Never drive with the head restraints not properly adjusted, head restraints removed or inserted in a flipped condition. With no support behind your head, your neck could be seriously injured in a collision.*



### 5.3 Second Row Bench Seat

#### WARNING

*Loading cargo on the seats is dangerous. The cargo becomes a projectile that could hit and injure passengers in a sudden stop or collision. Cargo should always be kept on the floor.*

#### Seat Back Fold (if equipped)

The second row seat back can be folded forward for maximum cargo space.

To fold the second row seat back down, pull the strap at the rear bottom of the seat firmly and push seat back forward. Ensure the head restraints on the second row seat are lowered all the way down before attempting to fold.

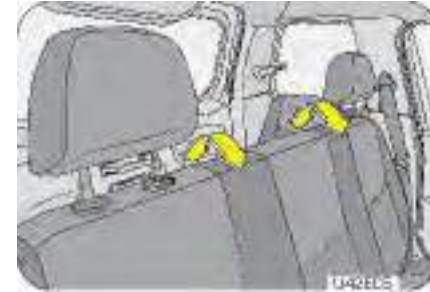
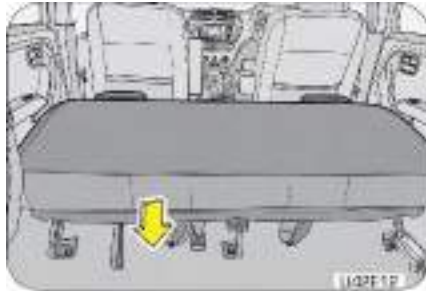

### 5.4 Third Row Seats





The third row side facing jump seats can be folded to maximise cargo space.

- Swing the seat cushion fully up
- Fold the seat leg completely down
- Secure the seat by fastening the hook & strap provided on the bottom of the cushion to the loop provided behind the Seat Back

## 5.5 General Warnings and Instructions- Seat Belts

At least once each month, inspect the seat belt webbing for any cuts, tears, or other signs of wear (such as fraying along the edges). Also inspect the anchors, retractors, and buckles to be sure they are tight and operational.

- All occupants, including the driver, should always wear their seat belt no matter how short the trip in order to minimize the risk of severe injury in the event of a crash. In an accident, an un-belted passenger becomes a projectile, and can cause serious injury to himself or another passenger.
- In a rollover crash, an un-belted person is significantly more likely prone to injury than a person wearing a seat belt
- In order to be properly buckled, you must always sit up straight and keep your feet on the floor in front of you. The lap part must be worn low and tight across your hips, just touching the top of your thighs. While fastening the seat belt, the shoulder strap of the seat belt must pass over your chest and top of your shoulder. It must never touch your neck, face, the side of your shoulder, arm, or pass under your arm. The belt must always be flat against your body and not twisted in any way. Nothing, such as an arm rest, a pocketbook, or any external objects should be between you and the seat belt. *Improper wearing* of a seat belt will reduce the protection in an *accident*.
- Seat belts should be adjusted as tightly as possible, consistent with comfort to properly secure the wearer in the seat.



- The seat belts provided for your vehicle are designed for people of adult size, must be properly used and maintained.
- For usage of adult seatbelt to secure children refer to section on manual for child seat positions and use a child restraint systems



- Passengers should not move out of or change seats while the vehicle is moving. A passenger who is not wearing a seat belt can be thrown against the inside of the vehicle, against other

occupants, or out of the vehicle during a crash or emergency stop

- Do not use any accessories on seat belts or modify in any way the seat belt system. Devices claiming to improve occupant comfort or reposition the seat belt can reduce the protection provided by the seat belt and increase the chance of serious injury in a crash
- An accident or emergency stop, can damage your seat belt system, even if the accident is “minor”. Please have your Authorized Mahindra Dealer inspect the seat belt system after an accident
- Please be aware that any unsecured item in your vehicle, such as your pet, unsecured child restraint system, a laptop or mobile phones, can become a projectile in the event of an accident or sudden stop, causing injuries to occupants in the vehicle

#### WARNING

*Never use a damaged seat belt system. A damaged seat belt will not provide protection in an accident, resulting in serious injury.*

- Seat belt systems can be prone to abuse. They are not indestructible. They must be handled with care to avoid damage
- Keep the belts clean and dry. Belt retraction may become difficult if the belts and webbing are soiled. If they need cleaning, use a mild soap solution or lukewarm water. Never use bleach,



dye, or abrasive cleaners. These chemicals will severely weaken the belts

- Retractors in 3-point type seat belts retract the seat belts when not in use. The inertia lock and coil spring allow the belts to remain comfortable on users during normal driving. During accidents or abrupt stops, inertia locks restrict the sudden forward movement of the wearer

### Seat Belts - Patients

Persons with serious medical conditions should also wear a seat belt. Consult your doctor for specific recommendations before travel.

### Seat Belts - Pregnant Women



Pregnant women must also wear seat belts. Consult your doctor for specific recommendations.

The lap belt should be worn snugly and as low as possible over the hips. The shoulder belt should be worn across your shoulder, but never across the stomach area. When worn properly, the seat belt will protect both the mother and the foetus in an accident or emergency stop.

#### WARNING

*A pregnant woman should never wear the seat belt across the stomach area. This could lead to serious injuries to the foetus and/or the pregnant mother.*

#### WARNING

*Never wear twisted seat belts. Excessive forces will be transferred from the belt to the wearer, in a collision, resulting in serious personal injury.*

*Each seat belt is meant for use by one person only. Using one seat belt for more than one person at a time is dangerous. The seat belt will not be able to spread the impact forces properly leading to serious injuries.*

#### WARNING

*Never put a belt around a child being carried on the occupant's lap. This could lead to serious injuries.*

**Seat Belt Usage is Necessary to:**

- Reduce the possibility of being thrown from your vehicle
- Reduce the possibility of injuries to upper body, lower body and legs during an accident
- Hold the driver in a position which allows better control of the vehicle

Children who are too large for child restraint systems should always occupy the rear seat and use the vehicle seat belts. The lap portion should be fastened snug on the hips and as low as possible and the shoulder strap should be across the child's shoulder, not the neck or face. If you are unable to position the strap across the child's shoulder, the child should remain in a booster seat. Frequently check the seat belt to be sure it remains snug and in position. A squirming child could cause the seat belt to come out of position.

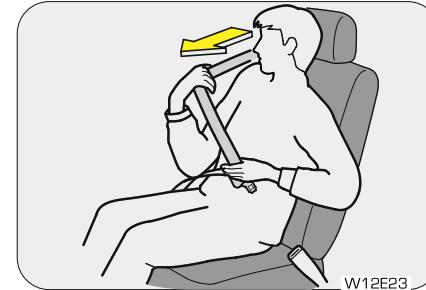
**5.6 Fastening the Seat Belt****5.6.1 Three Point type (if equipped)**

Adjust the seat as needed and sit up straight and well back in the seat. To fasten your seat belt, pull the webbing out of the retractor and insert the metal tongue into the buckle. There will be an audible





“click” when the tab locks into the buckle. Pull up on the shoulder strap to tighten the lap belt across your hips. The seat belt retractor will pull in any slack in the shoulder strap. A slow and easy motion will allow the belt to extend and let you move your body around freely.

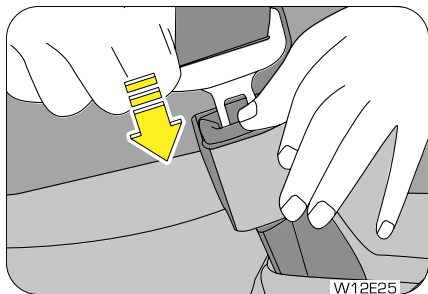

Periodically check the seat belt as you ride to be sure it remains snug and in position. If there is a sudden stop or impact, the belt will lock into position. It will also lock (restrict) if you try to lean forward too quickly.

#### NOTICE

*If the driver's seat belt is not fastened when the ignition is switched ON, the seat belt warning lamp illuminates. Refer to 'Warning Lamps' in the 'Features and Control' chapter for further details.*

### 5.6.2 Two Point Lap type (if equipped)

This seat belt is applicable to the second row middle passenger seat. Insert the metal tongue into the buckle until it snaps. Position the lap belt on the hips as low as possible.

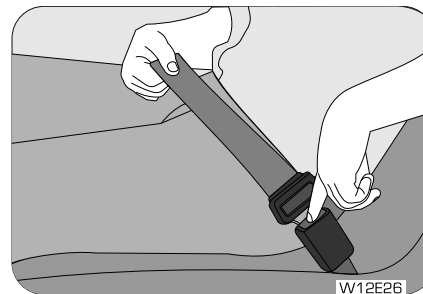



### 5.6.3 Unfastening the Seat Belt (both 3-Point & 2-Point)

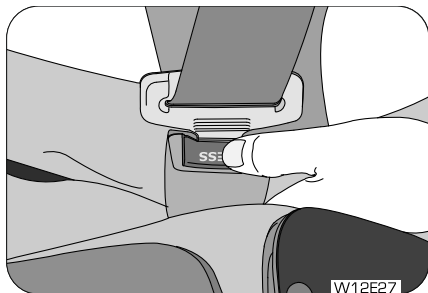

To release the belt, press the buckle release button and allow the belt to retract. If the belt does not retract smoothly, pull it out and check for kinks or twists. Then make sure it remains untwisted as it retracts.

#### WARNING

*Never insert coins, clips, etc. in the buckle as this may prevent you from properly latching the tongue and may cause damage to the buckle mechanism, thereby making the seat belt ineffective in an accident, resulting in serious personal injury.*

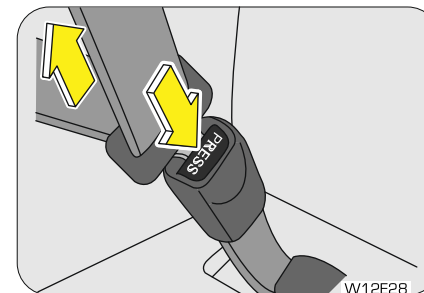

### 5.7 Child Restraint System (CRS)

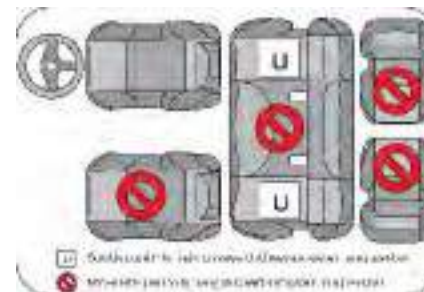

Always secure a child in a proper Child Restraints System in accordance with age and size of the child as recommended by the child restraint system manufacturer. Be sure to follow the Child



Restraint System (Child seat) manufacturer's instructions for seat belt routing.

 **WARNING**

*Do not allow children to stand up or kneel on either the rear or the front seats. An unrestrained child could suffer serious injuries during emergency braking or collision.*

**Legend:**

*U – Suitable position for using universal child restraint system using seat belt and buckles marked with 'CRS'.*

*∅ – Not Suitable position for using child restraint system using seat belt.*

Mass Group	Weight of Child (kg)	Fitting the child restraints system using seat belt
<b>Group 0</b>	0-10	Rear-facing child restraint system on the outboard 2 <sup>nd</sup> row seats using seat belt.
<b>Group 0+</b>	upto 13	
<b>Group 1</b>	9-18	Forward-facing child restraint system on the outboard 2 <sup>nd</sup> row seat using seat belt.
<b>Group 2</b>	15-25	
<b>Group 3</b>	22-36	



## 6 SUPPLEMENTAL RESTRAINT SYSTEM (SRS) (if equipped)

### 6.1 Airbags

Your vehicle is equipped with the following airbags:

- A frontal airbag for the driver
- A frontal airbag for the front passenger.

Airbags are located in:

- The steering wheel hub
- The passenger side instrument panel

They are indicated by "AIRBAG" embossed on the covers.

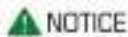

*An airbag is not designed to deploy in every type of crash. Depending on the type of accident or impact, the front airbags independently deploy thereby protecting the occupants. It is not necessary that ALL the airbags deploy during an accident.*

To minimize the risk of severe injury in the event of a crash, every passenger must always wear their seat belt (see the chapter on Seat Belts in this manual). The airbags inflate very quickly with great force. Do not position any part of your body too close to a airbag, you or especially children could be seriously injured/killed by a deploying airbag.

### 6.2 Introduction

The airbags are designed to provide further protection to the vehicle occupants in addition to the primary protection provided by the seat belts and seat belt pre-tensioners.

The primary components of the system are the sensors which measure the crash severity. In the event of a significant frontal impact, the airbags inflate to work in conjunction with the seat belts and help reduce injuries mainly to the driver's or front passenger's head/chest.



*Seat belts are the primary restraint system in the vehicle. An airbag provides supplemental protection in addition to the seat belts.*

*All occupants, including the driver, should always wear their seat belts irrespective of presence of airbags to minimize the risk of severe injury in the event of a crash.*

*Airbags are more effective in reducing injuries when the seat belts are worn.*

#### 6.2.1 Driver and Front Passenger Air Bag(If equipped)

Your vehicle is equipped with a Airbag and lap/shoulder belts at both the driver and front passenger seating positions. The indications of the system's presence are the letters "AIR BAG"



embossed on the airbag pad cover in the steering wheel and the passenger's side front panel pad above the glove box.

The SRS is designed to deploy the front airbags only when an impact is sufficiently severe and when the impact angle is less than  $\pm 30^\circ$  from the forward longitudinal axis of the vehicle.



Front airbags are not intended to deploy in side-impact, rear impact or rollover crashes. In addition, front airbags will not deploy in frontal crashes which are below the prescribed deployment threshold where risk of serious injuries is low.

### NOTICE

*Do not place any objects over the airbag or between the airbag and yourself.*

## 6.2.2 Airbag System Malfunction Lamp



Airbags do not require any regular maintenance of service. The airbag system malfunction lamp illuminates when the ignition is ON as self check confirming normal operations of airbag system and malfunction lamp.

This lamp monitors airbag sensor assembly, airbag sensors, indicator lamp, seat belt pre-tensioner assemblies, inflators, interconnecting wiring and power sources.

If either of the following conditions occur, there is a malfunction of the airbags or seat belt pre-tensioner. Immediately contact your Mahindra Dealer.

- The lamp does not glow when the ignition is switched ON or glows beyond six (6) seconds after switching the ignition ON
- The lamp comes ON at any other time, even briefly



- The lamp comes ON intermittently

### NOTICE

*Never make any modifications to your vehicle which could affect the performance of your airbag system. In particular, changes to the vehicle frame, bumpers, bull bar, front fenders, ride height, suspension, seat belts, interior trim, seats or steering wheel (especially covers, pads or other trim), could prevent proper deployment of the airbag. If you need to make any modifications to accommodate any disability you may have, please contact your Authorized Mahindra Dealer.*

*Never try to open or strike the airbag cover. If the airbag cover is cracked or damaged in any way, the airbag may not function as intended. Take the vehicle to an Authorized Mahindra Dealer.*

Even if the airbags do not deploy during an accident, take your vehicle to an authorized Mahindra Dealer for a thorough inspection of the airbag and seat belt systems, no matter how minor the accident. The airbag system could have been damaged, and may not work as intended in the future, resulting in serious injury.

## 6.2.3 Airbag Inflation/Deployment

The airbag sensors constantly monitor the forward deceleration of the vehicle. If an impact results in a forward deceleration beyond the designed threshold level, the system triggers the airbag inflators. This initiates a chemical reaction which quickly fills the airbags with non-toxic gas.

Upon deployment, tear seams molded directly into the pad covers separate under pressure from the expansion of the airbags. Further opening of the covers allows full inflation of the airbags. A fully inflated airbag, in combination with a properly worn seat belt, slows the driver's or the passenger's forward motion, reducing the risk of head and chest injury.

After complete inflation, the airbag immediately starts deflating, enabling the driver to maintain forward visibility and the ability to maneuver or operate other controls.

Deployment of the airbags happen in a fraction of a second, producing a loud noise releasing a 'white smoke' and residue along with a non-toxic gas. This does not indicate a fire. This smoke may remain inside the vehicle for some time, and may cause some minor irritation to the eyes, skin or breathing. Be sure to wash off any residue with soap and water as soon as possible to prevent any potential skin irritation. If you can safely exit the vehicle, you should do so immediately.

### WARNING

- *Do not modify, remove, strike or open the seat belt pretensioner assemblies, airbag sensor or surrounding area or wiring. Failure to follow these instructions may prevent them from activating correctly, cause sudden operation of the system or disable the system, which could result in serious injury*



- *Parts of the airbag module (steering wheel hub, airbag cover and inflator) may be hot for several minutes after deployment. The airbags inflate only once*
- *Do not cover the steering wheel, instrument panel, seats with any object (e.g. dash panel covers, seat covers) which may prevent the airbags from inflating properly*
- *The airbags inflate with considerable force. While the system is designed to reduce serious injuries, primarily to the head and chest, it may also cause other, less severe injuries to the face, chest, arms and hands. These are usually in the nature of minor burns or abrasions and swelling, but the force of a deploying airbag can also cause more serious injuries, especially if an occupant's hands, arms, chest or head is in close proximity to the airbag module at the time of deployment. Sit straight and well back into the seat. Move your seat as far back as practical to allow room for airbag inflation, while still allowing you to properly operate/drive the vehicle*

#### WARNING

*The front passenger should never sit on the edge of the seat, stand near the glove compartment, rest feet or other parts of the body on the dashboard when the vehicle is moving.*



#### WARNING

*The driver or front passenger who is too close to the steering wheel or dashboard can be seriously injured during airbag deployment.*

- *The driver must sit as far back as possible from the steering wheel while still maintaining control of the vehicle*
- *The front passenger must sit as far back as possible from the dashboard*
- *Sitting improperly or out of position can cause occupants to be shifted too close to a deploying airbag, strike the interior structure or be thrown from the vehicle resulting in serious injury*



- *All infants and children must be placed in the rear seat of the vehicle in a child restraint seat and be properly restrained by seat belts*
- *Front airbags can injure occupants improperly positioned in the front seats*
- *Even with airbags, improperly belted and un-belted occupants can be severely injured when the airbag inflates. Always follow the precautions about seat belts, airbags and occupant safety contained in this manual*
- *Do not modify the front seats. Modification of the front seats could interfere with the operation of the supplemental restraint system or side impact airbags*
- *Do not place items under the front seats. Placing items under the front seats could interfere with the operation of the supplemental restraint system sensing components and wiring harnesses*

 **WARNING**

- *Always sit upright with the seat back in an upright position, on the seat cushion centre with your seat belt on, legs comfortably extended and your feet on the floor*
- *All vehicle occupants must be properly restrained using the seat belts*





## 6.2.4 Child Restraint and Airbag



Never place a rear-facing child restraint in the front passenger's seat. If the airbag deploys, injuries to the child may be fatal.

In addition, do not place front-facing child restraints in the front passenger's seat either. If the front passenger airbag inflates, it could cause serious or fatal injuries to the child.

### DANGER

*Extreme Hazard! Do not use a rear facing child restraint on a seat protected by an airbag in front of it!*

*Never put a child restraint in the front passenger's seat. If the front passenger airbag inflates, it can cause serious or fatal injuries.*

*Never hold an infant or child on your lap. The infant or child could be seriously injured in the event of a crash. All infants and*

*children should be properly restrained in appropriate child safety seats or seat belts in the rear seat.*

*Install the child restraint system on the rear outboard seats, and securely lock the child restraint system in position.*

*Always Buckle Children (ABC) in the back seat. It is the safest place for children of any age to ride.*

## 6.2.5 Airbag Deployment

### NOTICE

*The images shown in this section are for illustrative purpose only. They may not look like your model/variant or vehicle.*

### Front Air bag's

Front air bags are designed to inflate in a frontal collision depending on the intensity, speed or angles of impact of the front collision.





### Airbag Non-deployment

Impacts below a pre-determined threshold level may not cause the airbag's to deploy in the following cases:

- **Collision with Utility Poles or Trees -**



Air bags may not inflate if the vehicle collides with objects such as utility poles or trees, where the point of impact is concentrated to one area and the full force of the impact is not delivered to the sensors.

- **Under-ride Situations -**

Running under a truck's tail gate may not provide the decelerations necessary for airbag deployment. Just before impact, drivers often brake heavily. Such heavy braking lowers the front portion of the vehicle causing it to "ride" under a vehicle with a higher ground clearance. Air bags may not inflate in this "under-ride" situation where deceleration forces that are

detected by sensors may be significantly reduced by such "under-ride" collisions.

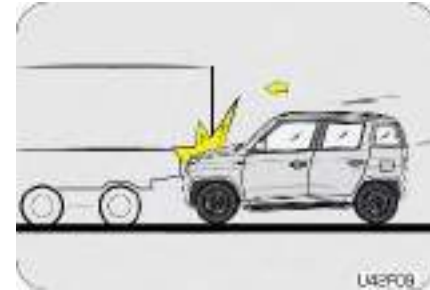

- **Rear-end Collisions -**

Frontal air bags are not designed to inflate in rear collisions, where occupants are moved backward away from the airbags by the force of the impact. In this case, inflated air bags would not be able to provide any additional benefit.





- **Frontal Impact -**

Frontal impact beyond 30° range from head-on to the vehicle.

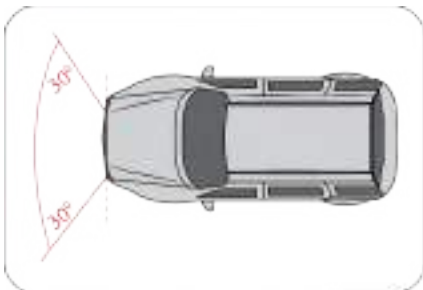

- **Pot Holes or Stepped Surfaces -**

Driving into a big pot-hole, stepped surface or hitting the far side of a hole/incline will not inflate the airbag.



- **Rollover -**

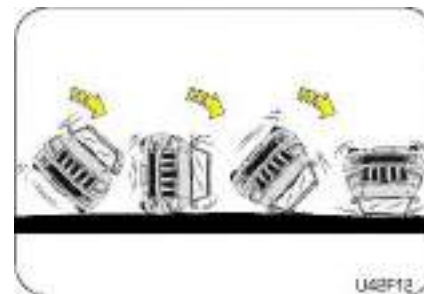

Air bags will not inflate in rollover accidents where air bag deployment would not provide protection to the occupants.

- **Frontal Side Swipe Impact -**



Frontal offset impact to the vehicle may not provide the deceleration force necessary for airbag deployment. In an angled



collision, the force of impact may direct the occupants in a direction where the air bags would not be able to provide any additional benefit, and thus the sensors may not deploy any air bags.

### **6.2.6 Airbag Replacement**

Self-servicing or tampering with the airbag system is dangerous. An airbag could accidentally deploy causing serious injuries, or will not deploy when there is a need. Always take your vehicle to an authorized Mahindra dealer for inspection and repairs.

### **6.2.7 Self Removing SRS Related Parts**

Self removing the instrument panel, steering wheel, seats or airbag related parts or sensors is not recommended. Airbags could accidentally activate and cause serious injuries, or they may not deploy when there is a need. Visit an authorized Mahindra dealer if these parts must be removed.

### **6.2.8 Airbag Disposal**

Improper disposal of an airbag or a vehicle with live airbags can be extremely dangerous. Approach an authorized Mahindra dealer to do these jobs.

### **6.2.9 Airbag Repair**

If the front airbag cover or IP airbag cover shows signs of damage or having been removed, the vehicle should be towed to the nearest authorized Mahindra dealer for repair. Do not attempt to self repair or reinstall the cover.

### **6.2.10 Airbag Maintenance**

For cleaning the airbag covers/areas, use only a soft dry cloth or one which has been moistened with plain water. Solvents or cleaners could adversely affect the airbag covers and proper deployment of the system.





## 7 LOCKS AND KEYS

### 7.1 Locks and Keys

#### A Word About Your Keys :

TUV300 comes with two types of keys based on the model/variant;

- Conventional key
- Remote Keyless Entry (RKE):

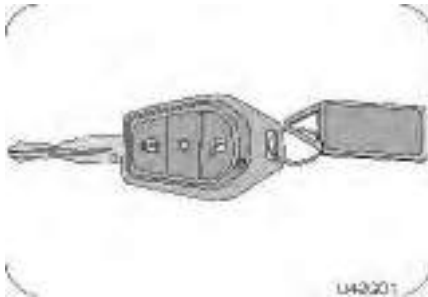

#### Key Number Tag:

Your key number is shown on the plastic tag attached to the key. It is recommended that you record the key number and store in a safe place. The keys operate all locks in your vehicle including those of the doors and ignition with steering lock. We advise you to keep one of these keys in a safe place for emergency use, but not in the

vehicle. Should you lose your keys or if you need replacement keys, they can be ordered through an Authorized Mahindra Dealer.

#### NOTICE

*There is a limitation (max 2 keys at a time) to the number of keys that can be programmed. The minimum time frame required to supply the duplicate keys is 20 days after all the formalities are completed. Please contact the dealer to understand the formalities involved.*

#### WARNING

*Never leave the key in the ignition switch with children in the vehicle. A child could switch on the ignition, start the engine, operate power windows and other controls, or move the vehicle, resulting in personal injuries to bystanders and/or children seated inside.*



**To Open a Door from Inside:**

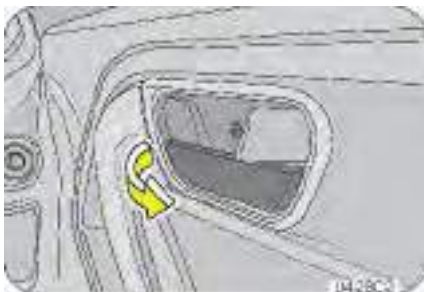

**Locking/Unlocking Individual Doors from Inside :**

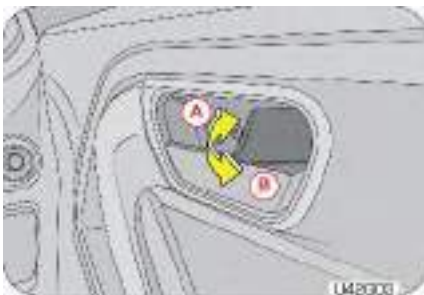

A	Lock	B	Unlock
---	------	---	--------

**▲ NOTICE**

*Locking the driver door from inside activates the central locking system (if equipped), thereby locking ALL the doors of the vehicle. Refer to the 'Central Locking' section for further details.*

**Locking/Unlocking Doors from Outside :**

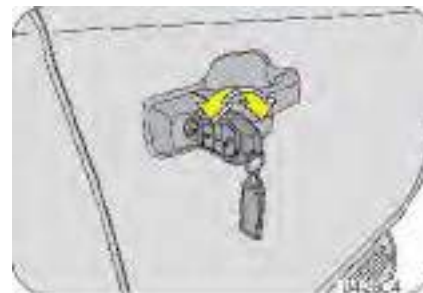

**▲ NOTICE**

*The key is bi-directional; you can insert it into the key hole in both directions. Locking the driver door from outside activates the central locking system (if equipped), thereby locking ALL the doors of the vehicle. Refer to the 'Central Locking' section for further details.*



### Locking/Unlocking the Back Door :

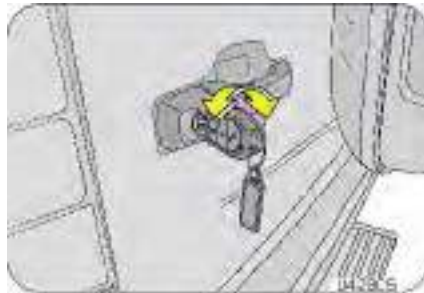
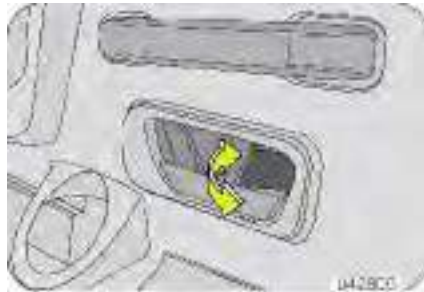

## 7.2 Central Locking System

All doors of the vehicle can be simultaneously locked or unlocked from the driver door.

### Central Locking/Unlocking All Doors from Outside

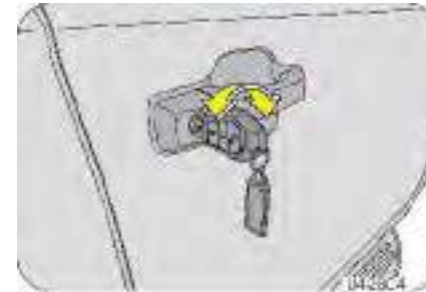

#### NOTICE

*In case any door including the back door is open when the central locking is activated, that door will not be locked even if it is closed later.*





**Central Locking/Unlocking All Doors from Inside**

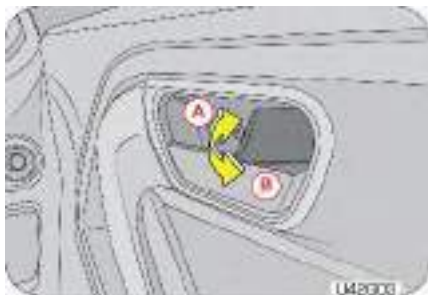

A	Lock	B	Unlock
---	------	---	--------

A	UnLock	B	Lock
---	--------	---	------

Your vehicle is equipped with child safety locks in the rear doors. When the lock mechanism is engaged, the rear door(s) cannot be opened from the inside. The door(s) can only be opened from the outside.

Move the tab up/down in the slot provided in the side face of rear door to disable/enable the child safety rear door lock.



*If the rear doors are not operable from inside, ensure that the child safety locks have been disabled.*

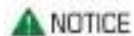

*Mahindra strongly recommends that the child safety rear door locks be used whenever there are children traveling in the rear seat.*

**7.2.1 Child Safety Rear Door Lock**





## 7.3 Remote Keyless Entry (RKE) System

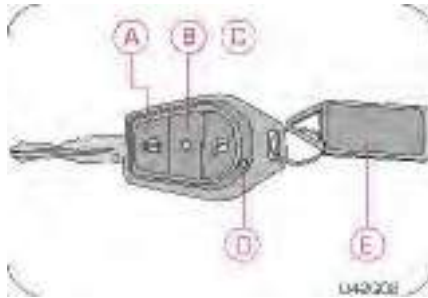

A	Lock
B	Search (Panic Alarm)
C	Unlock
D	LED
E	Key Tag

### 7.3.1 To Lock and Arm the Vehicle with RKE



Press the LOCK button on the RKE for locking and arming the vehicle.

**Hazard lamps flash once** - if all the doors in the vehicle are locked and armed successfully using RKE.

**Hazard lamps flash five times along with an alarm** - if any of the doors (including bonnet) in the vehicle are open.



### 7.3.2 Unlock and Disarm the Vehicle with RKE



Press the UNLOCK button on the RKE to unlock and disarm the vehicle.

**Hazard lamps flash twice** - if there was no theft attempt during the lock (armed) period.

**Hazard lamps flash four times along with an alarm** - if there was a theft attempt during the lock (armed) period.



#### NOTICE

*Upon the remote lock, if any of the doors are not closed properly or are left open, the hazard lamps will flash five times to indicate the same.*

### 7.3.3 Auto Locking

All doors will get locked automatically when;

- All doors are closed properly
- Vehicle speed is greater than 20 kmph

**Auto Locking ON DOOR OPEN** – Once the autolock has been activated, if any door is opened, then the autolock will reactivate only if all doors are closed, the vehicle speed goes above 20 kmph and the master actuator is in the unlock position.

**Auto Locking ON MASTER ACTUATOR UNLOCK** – Once the auto lock has been activated, if the master actuator was unlocked at any vehicle speed, then the auto lock will reactivate only when the vehicle speed goes below 5 kmph and further crosses 20 kmph.

### 7.3.4 Auto Unlocking

Auto Unlock of all doors will happen in the following conditions ;

- When Ignition is switched from ON to OFF, OR
- In the event of a crash (only on Airbag Variants)

### 7.3.5 Auto Re-locking

Auto Re-lock of all doors will happen when;



- No door status change for 45 sec after unlocking the vehicle using RKE

### 7.3.6 Search (Panic) Function



Press the SEARCH/PANIC button on the RKE to locate the vehicle in a parking lot. Panic alarm can also bring attention to the vehicle and surrounding area, warning about an intruder or seek for help.

When the SEARCH/PANIC function is ON, the hazard lamps flash along with an alarm for 30 sec. In this mode;

- Pressing the SEARCH button again switches OFF the alarm
- Pressing the UNLOCK button switches OFF the alarm and disarms/unlocks all doors

#### NOTICE

*The search function works both during the Locked/Unlocked conditions of the vehicle.*

### 7.3.7 Mute/Un-mute Function

The chirps can be muted / un-muted. Press the LOCK & SEARCH buttons together for 3 sec. to toggle between MUTE/UN-MUTE mode. Hazard lamps will flash once to indicate the change in status.

#### NOTICE

*In the un-muted condition, alarm chirps can be heard during Auto Re-lock (1 Chirp), RKE Lock when door open (5 Chirps) and RKE Unlock if there was a theft attempt during the lock (armed) period (4 Chirps).*

*In the mute condition, only hazard would flash and alarm chirps would not be audible.*



### 7.3.8 Theft Alarm

Vehicle enters into alarm mode when there is a change in door status/ignition status provided the vehicle was locked through RKE.

- Alarm time - Pre-alarm (alarm with less intensity) for 5 sec. and continuous alarm for 25 sec. for the first time
- If there is any change in door/ignition status for the second time, the system enters the alarm state for 30 sec. without any pre alarm

After the alarm period, there will not be any alarm again till any further change in the door/ignition status.

### ▲ NOTICE

*The security system (alarm) will be activated only when the vehicle is locked using the RKE. Locking the doors with the mechanical key will not trigger the alarm.*

*When the vehicle is armed by RKE, opening the door from the inside by operating the door inner handle or opening the door from the outside using the key will be treated as unauthorized activating the vehicle security alarm. If this occurs, the alarm can be disarmed by either pressing the 'UNLOCK' button on the RKE or turning ON the ignition followed by a successful authentication.*

### 7.3.9 RKE Operating Range



Using RKE, you can lock/arm or unlock/disarm the vehicle from distances approximately 9 m (30 ft) This is in open area.

**▲ NOTICE**

If there is reduction in RKE range, please follow the steps below:

- Check the distance: The RKE may be too far from the vehicle. Stand closer to the vehicle during rain or bad weather
- Check the location: Other vehicles or objects may be blocking the signals. Take a few steps to the left or right, hold the RKE higher, and try again. Moreover, closeness to a radio transmitter such as radio station tower, airport transmitter, mobile or CB radios may lead to reduction in range of RKE
- Check the RKE battery: See battery replacement procedure, given later in this section
- If the RKE is still not working correctly, contact an Authorized Mahindra Dealer

### 7.3.10 RKE Battery Replacement

If the RKE operation is inconsistent when any of the buttons are pressed then it indicates that the RKE battery is weak.

The rear side of the RKE is screw fitted. Using a small screw driver, unscrew and separate the two halves of the casing. The battery type is button type "CR1632 3V cell".

**▲ CAUTION**

*While prying the RKE case, take care not to damage the battery.*



### CAUTION

*Do not touch the battery terminals that are on the back housing or the printed circuit board.*

*Pull out the battery and discard the same. Insert new battery of same type. While fitting the new battery, ensure the positive side of the batteries face up. Align both the halves of the RKE and screw to tight fit. Check operation of the RKE.*

### 7.3.11 If RKE is Lost

If you have lost the programmed RKE, contact an Authorized Mahindra Dealer for procuring a new RKE.

While programming a new key set, you will have to submit all the keys available with you to an Authorized Mahindra Dealer.

### NOTICE

*There is a limitation (max 2 keys at a time) to the number of keys that can be programmed. The minimum time frame required to supply the duplicate keys is 20 days after all the formalities are completed. Please contact the dealer to understand the formalities involved.*

*If the key is stolen or lost, communicate to an Authorized Mahindra Dealer to de-activate the function of the lost or stolen key. This is essential to avoid unauthorized access using the misplaced key.*

*Only RKE transmitters programmed to your vehicle electronics can be used for remote locking and unlocking of your vehicle.*

### 7.3.12 Precautions while Handling RKE:

- Do not cover the key grip with any material that cuts off RF waves
- Do not leave the key exposed to high temperatures for a long period, such as on the dashboard or hood under direct sunlight
- Do not put the key in any liquid or wash it in an ultrasonic washer

## 7.4 Engine Immobilizer System

The Engine Immobilizer System is a security system that prevents the vehicle being operated by an unauthorized person. The Engine immobilizer prevents the engine from being started unless it recognizes signals from the correct coded key.

The system is automatically activated when the key is removed from the ignition.

### NOTICE

*In order to safeguard the theft protection system of the vehicle, Mahindra will not supply EMS ECU (Engine Management System - Electronic Control Unit), vehicle keys and the ICU as a set for any vehicle.*



## 7.4.1 Features of the Immobilizer System

- Prevents the vehicle being started by anyone not in possession of the correct vehicle key
- The vehicle is automatically protected after the key is removed from the ignition. At every ignition ON, if the vehicle does not recognize the correct key code, the engine check lamp will illuminate/blink and the engine cannot be started
- The vehicle will not be protected until the key has been taken out of the ignition

### CAUTION

*If the engine check lamp flashes or remains continuously illuminated after the ignition being switched ON, there is a system malfunction. Contact an Authorized Mahindra Dealer immediately.*

Inserting the correct coded key in the ignition and switching the ignition ON, automatically deactivates the system. This enables the engine to start.

### NOTICE

*In the event of the vehicle not starting with the correct key, switch off the ignition and remove for a minimum of 1 minute before attempting to start the vehicle again.*

### CAUTION

*Do not modify, remove or disassemble the engine immobilizer system. Any unauthorized changes or modifications can affect proper operation of the system and will void your warranty.*

*Do not attempt to install after market 'push-button' start systems. These systems may compromise your vehicle's security system.*







## 8 FEATURES AND CONTROL

### 8.1 Power Windows

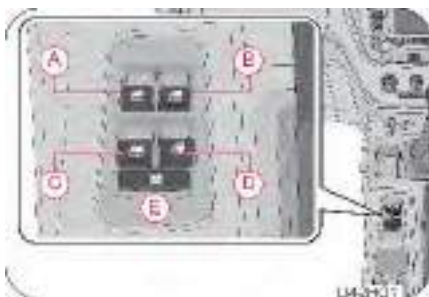

A	Front Passenger Window Switch	D	Rear RH Window Switch
B	Driver Door Window Switch	E	Power Window Lock Switch (Child Safety)
C	Rear LH Window Switch		

The quadruple switch controls the window winding functions of all the doors of the vehicle and is located on the floor console. It also houses a rear power windows lock switch for child safety that enables/disables the power window operation of both the rear doors when operated independently from the respective door.

To lower/raise the window glass push/pull the respective power window switch.



Rear passengers can also raise or lower their respective window glasses individually by the separate switches provided on both the door trim pads.



#### NOTICE

*This switch will not work if the switch lock at the driver control bank is pressed*



### ⚠ CAUTION

*Power windows can be operated only when the ignition is "IGN" position.*

*Do not operate the power windows frequently when the engine is OFF. This will drain the vehicle battery.*

*If you operate the switch often during a short period of time, the system might become inoperable for a certain duration to prevent damage due to overheating. The system will return to normal functioning shortly. It is recommended operating one window switch at a time.*

### ⚠ WARNING

*While operating the power windows, check for obstructions like a head, hand, etc. which may lead to personal injuries.*

#### 8.1.1 Power Window Lock Switch

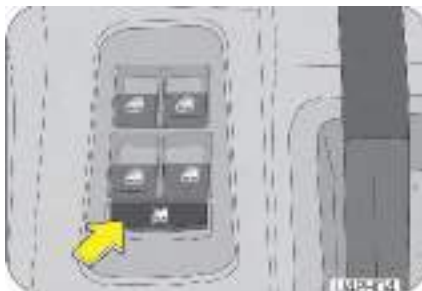

A power window lock switch is provided in the quadruple switch bank which toggles the operation of the rear passenger power window switches.

#### 8.2 Butterfly Window (Rear Quarter Window)

To open the rear quarter window (butterfly window), pull the latch handle towards you and push the window out completely. For closing the window, pull and lock the latch handle which will bring the rear quarter window back to its original closed position.

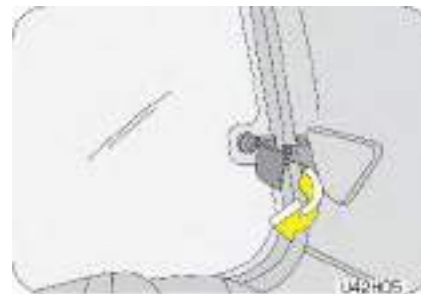

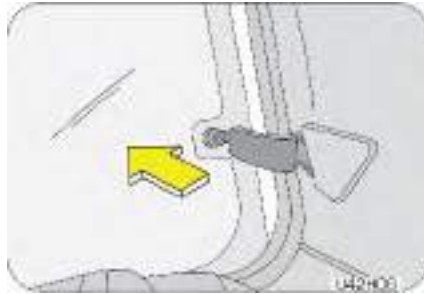

*Do not allow children to operate the quarter window. Pinching fingers is inevitable if not operated properly. Make sure it is operated only by adults.*

### 8.3 Outside Rear View Mirror (ORVM)

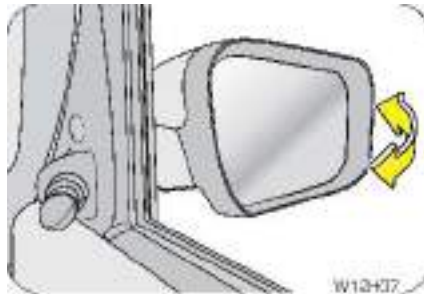

Integrated exterior rear view mirrors on both the sides facilitate maximum rear view information to the driver.

Both the ORVM's are hinged and can be manually folded or unfolded. This avoids hindrances in narrow areas and parking slots. Make sure that you fully engage the mirror in its support, while folding or unfolding.



*Do not overestimate the distance of the objects that you see in the mirrors. Objects seen in convex mirrors are much closer than they appear.*

#### 8.3.1 Tip-Tap ORVM Adjustment (if equipped)

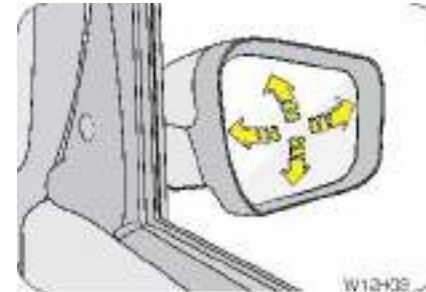



Tip Tap ORVM's can be adjusted by hand in the direction as indicated by the arrows. Adjust the mirror as required to bring the rear traffic vision as desired.

### 8.3.2 Manual (Joystick) ORVM Adjustment (if equipped)

Manual ORVM's can be adjusted by the joystick provided on the ORVM trim. Adjust the joy stick as required to bring the rear traffic vision as desired.

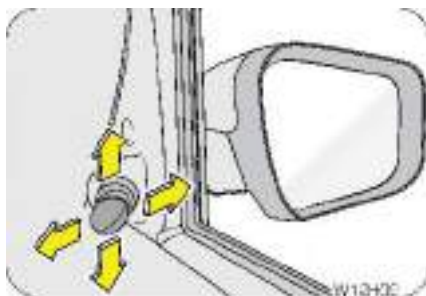

### 8.3.3 Electric ORVM Adjustment (if equipped)

The electric exterior mirror adjustment switch is located on the RHS of instrument panel adjacent to the head lamp levelling switch. The joystick on the switch can be used to select the left/right mirror and also to adjust the respective mirror.

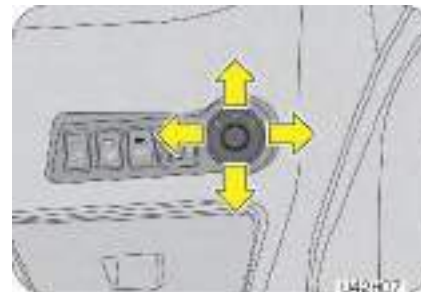

## 8.4 Interior Mirror



The interior mirror has day and night (anti-glare) positions. The night position reduces glare from head lamps of vehicles behind you. Flip the tab on the bottom edge of the mirror to select the day or night position.



## 8.5 Exterior Lamps

The lighting control stalk is located on the right hand side of the steering wheel. It controls operations of parking lamps, head lamps, head lamp beam selection, high beam flashing, fog lamps (if equipped) and turn signals when the ignition switch is ON.



### 8.5.1 Turn Signals



A Turn Signal - Left

B Turn Signal - Right

#### Lane Changing

You can signal a lane change by moving the lighting control stalk clockwise or anti-clockwise to the limit point of free movement of the lever and releasing it once you change the lane.



#### NOTICE

*After you have completed your turn, the stalk will automatically return to the neutral position.*

*If the turn signal lamps on the instrument panel flash faster than normal, there may be a possibility that one or more of the*



turn signal lamp bulbs have blown. Replace the blown bulb immediately.

### 8.5.2 Lamps Off

Rotate the outer rotary switch on the lighting control stalk aligning the 'arrow' on the switch to 'O' on the stalk to switch OFF all lamps.



### 8.5.3 Parking Lamps On



Rotate the outer rotary switch on the lighting control stalk aligning the 'arrow' on the switch to the '1st détente' position on the stalk to switch ON the parking lamps.

#### CAUTION

*The tail lamp, license plate lamp, front park lamp and instrument panel illumination lamps are activated when the parking lamp is switched ON.*

### 8.5.4 Head Lamp On

Rotate the outer rotary switch on the lighting control stalk aligning the 'dot' on the switch to the '2nd détente' position on the stalk to switch ON the head lamps.



beam. The head lamp high beam telltale lamp in the instrument cluster illuminates indicating high beam option selected. For low beam, pull the stalk back up.

#### NOTICE

*Your vehicle head lamps are vented and moisture may be collected on the inside of the head lamp lens under certain climatic and geographical conditions. This moisture will evaporate once the head lamps have been switched ON for a few minutes.*

### 8.5.5 Head Lamp High Beam/Low Beam



### 8.5.6 Head Lamp Flash



A	Low Beam
---	----------

B	High Beam
---	-----------

With the head lamp low beam ON, push the lighting control stalk down [away] from steering wheel to switch ON the head lamp high

Pull the lighting control stalk (from the head lamp low beam position) towards the steering wheel to instantaneously flash the head lamp high beam. The head lamp flash works even when the head lamp is OFF.





### 8.5.7 Head Lamp Leveling System

When the vehicle is either fully or partially loaded, it may have an upward inclination disturbing the head lamp aiming. A correct head lamp setting provides good visibility to the driver with minimum inconvenience to other road users.

To properly aim the head lamp beam, use the head lamp leveling switch. This switch is located on the right side of the steering column shroud in the instrument panel. This switch has three positions marked as 0, 1 & 2.



Switch Position	Vehicle Loading Condition
0	Driver only or Driver with front passenger
1	Driver + Front passenger + Rear seat occupied
2	All seats occupied
3	All seats occupied with luggage OR Driver with luggage at extreme rear side

Select the suitable switch position depending on the pay load as advised in the table.



*The headlights can only be adjusted when the low beam is switched ON.*

### 8.5.8 Power ECO Switch

Power economy switch helps you to improve the fuel efficiency of the vehicle. It is located on the driver panel next to the Head lamp levelling switch

Press the switch gently once to switch between modes. The ECO mode is indicated by LED illumination in the switch. Whenever ECO switch is pressed in vehicle the ECO lamp will turn ON in Cluster and it will indicate that the vehicle is running in economy mode



**▲ NOTICE**

Power or Economy mode can be changed at any time in vehicle running condition. Select the suitable mode depending on the requirement.

If the vehicle is in ECO mode, when engine is switched off and restarted, still vehicle will be in ECO mode. ECO ON or OFF is indicated by the light in the ECO mode button.

### 8.5.9 Hazard on Panic Braking

Hazard Lamps are turned ON during panic braking for 5 sec when the following conditions are met;

- Ignition is ON
- Vehicle speed is greater than 100 kmph
- Brake is applied
- Sudden High deceleration Rate

### 8.5.10 Static Bending Lamps (if equipped)

Static bending lamps are integrated in both the head lamps. Static bending lamps turn ON when a sharp turn is taken. They help in illuminating the road in the direction of turn.

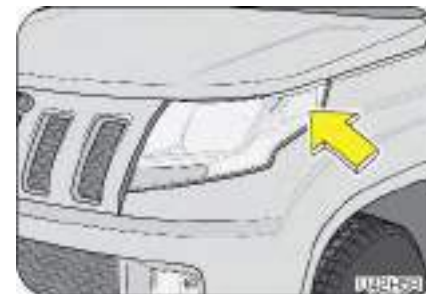

The following conditions are to be met for the lamps to switch ON;

- Ignition ON
- Head lamp is ON
- Sharp turn taken

### 8.5.11 Fog Lamps (if equipped)

Fog lamps are to be used along with the head lamp low beam, to improve the vision during foggy and misty conditions.



### Fog Lamps OFF

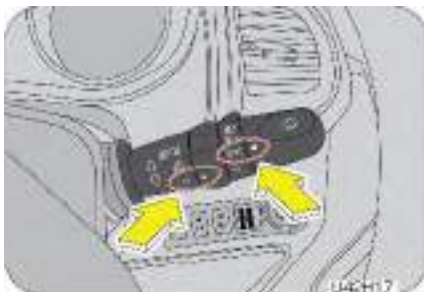

Align the inner rotary switch on the lighting control stalk to the fog lamp off 'O' on the inner fixed stalk as shown to switch OFF the fog lamps.

### Front Fog Lamps ON

To switch ON the front fog lamps, switch ON the ignition and the parking lamps. Turn the inner rotary switch on the lighting control stalk to align to the fog lamp symbol on the inner fixed stalk as shown.

The front fog lamp indicator in the instrument cluster indicates the operation status.



### NOTICE

*Fog lamps will turn ON only if the parking lamp is ON.*

### 8.5.12 Hazard Warning Lamp

The hazard warning lamp switch is located above the AC controls on the instrument panel. Use the hazard warning lamp when your vehicle is stationary or to warn other road users to be cautious while passing your vehicle.

To turn the hazard warning lamp ON, press the switch in. All the turn signal lamps flash. To turn OFF, press the switch again.

**NOTICE**

*The turn lamps do not work when the hazard warning lamps are operational.*

*Hazard lamps are also switched ON during the following conditions;*

- *Crash – Hazard would be turned on for 30 mins*
- *Panic Braking – When the vehicle is running above 100 kmph and panic/sudden brakes are applied, hazard will turn on for 5 sec*
- *Vehicle break down warning bonnet open – The vehicle break down warning would be enabled only when bonnet switch changes from close to open condition at vehicle unlocked condition*

*Pressing the hazard switch twice deactivates this feature.*

## 8.6 Follow-Me Home (FMH) RKE

This feature helps the driver and passengers to easily get out of the vehicle during poor light conditions. The head lamp low beam is turned ON for about 20 seconds, assisting the passengers to find their way unless cancelled by the UNLOCK signal from the RKE.

### To enable FMH;

- Ignition transition from ON to OFF
- Park lamp ON to OFF
- Ignition key is out
- Double press RKE LOCK
- Head lamp low beam will turn ON for 20 seconds unless cancelled by the UNLOCK signal

### To extend FMH;

- The first RKE LOCK command will be used for locking all doors
- Successive RKE LOCK commands will be used for toggling the current status of the head lamp low beam
- Each time FMH is extended, the head lamp low beam will be kept/turned on for the next 20 seconds
- If no extension is provided for 3 mins, FMH will get expired

### To disable FMH

- Park lamp transition from OFF to ON



- Ignition off to any other states
- FMH ON 20 seconds expires
- Max time of 3 mins has elapsed and no extension of FMH

With FMH mode ON, if the UNLOCK signal is received twice from RKE; the feature gets deactivated and cannot be extended further. Also, the doors are unlocked and vehicle disarmed.

### 8.7 Follow-Me Home (FMH) Non RKE

This feature helps the driver and passengers to easily get out of the vehicle during poor light conditions. The head lamp low beam is turned ON for about 20 seconds, assisting the passengers to find their way.

#### To enable FMH;

- Ignition transition from ON to OFF
- Park lamp ON to OFF
- Ignition key is out
- Open Driver door
- Head lamp low beam will turn ON for 20 seconds

#### To disable FMH

- FMH ON 20 seconds expires
- Park lamp transition from OFF to ON

### 8.8 Lead Me to Vehicle (LMV) (RKE)

LMV is the feature that switches the head lamp ON in low beam for 20 sec helping the passengers to reach the parked vehicle safely and comfortably at night.

#### To enable LMV;

- Ignition key is out
- Park lamps OFF
- Press UNLOCK button twice on the RKE
- System will unlock all doors and disarm the vehicle followed by head lamp turning ON for 20 sec

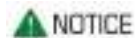

#### NOTICE

*If FMH has already expired, LMV would turn ON in the 2nd Press RKE Unlock.*

#### To extend LMV;

- Successive UNLOCK commands received from RKE is used for toggling the current status of the head lamp low beam
- Each time LMV is extended the low beam will be kept/turned on for next 20 seconds

#### To disable LMV;

- LMV ON 20 seconds expires



- Ignition off to any other states
- LOCK command is received from RKE
- Park lamp is switched ON

## 8.9 Interior Lamps

Interior lamps comprise of roof lamps and ignition key ring illumination. These lamps can be used for an illuminated entry. In auto mode, the roof lamps and ignition key ring illuminate when any of the doors are opened. Once all doors are closed, the interior lamps switch OFF.

### 8.9.1 Front Courtesy/Map Reading (if equipped)

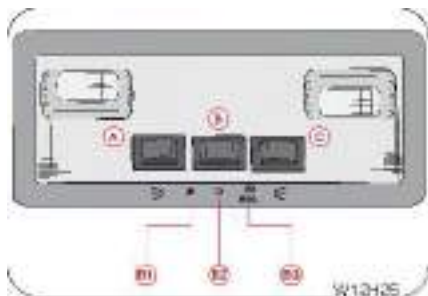

A	Map Reading Lamp (LH)	B1	Permanent ON
B	Roof Lamp	B2	Permanent OFF
C	Map Reading Lamp (RH)	B3	Door/Auto Mode

The front courtesy lamp is located in the roof console above the front seats. The courtesy lamp can be switched on using the middle switch (B) on the lamp.

The right/left map reading lamps for the driver/front passenger are located adjacent to the courtesy lamp and can be individually switched ON/OFF by the map reading lamp switches (A & C)



*Do not leave the courtesy/map reading lamp in permanent ON mode. This will drain your vehicle battery.*

### 8.9.2 Roof Lamps(if equipped)





Roof Lamp	Permanent ON
	Permanent OFF
	Door/Auto Mode

The Roof lamp is located in the roof above the front & Rear seats. The lamp can be switched on using the switch on the lamp.



*Do not leave the Roof lamp in permanent ON mode. This will drain your vehicle battery.*

The Roof lamp switch has three operation modes to choose from;

1. The lamp remains permanently ON in this position irrespective of the door open status
2. The lamp remains permanently OFF in this position
3. The lamp remains in AUTO mode in this position. The operation of the Roof lamp in Auto mode is as follows;
  - Roof lamp switches ON, dims and goes OFF after a preset delay once RKE unlock is performed
  - Roof lamp switches ON when any of the doors is/are open
  - Roof lamp switches ON when Ignition on to ignition off all doors closed condition
  - Roof lamps dim and go OFF after a preset delay upon closing of all doors during IGN OFF condition

- Roof lamps dim and go OFF immediately on RKE lock or manual key lock after all doors are closed
- If any of the doors are not closed properly, then the Roof lamps switch OFF automatically after a preset duration (during Key removal from key Barrel) or once the vehicle speed > 20 kmph
- Roof lamps go OFF with ignition ON and all doors closed properly

## 8.10 Power Outlet

There are two (on select variants) 12V power supply sockets provided for power take OFF depending on the vehicle variant. Electrical equipment/appliances like mobile phone charger, cigarette lighter, etc. can be used in the outlets. The power outlet is rated 12V/120W when the engine is ON.

The power outlets are located in the following places in the vehicle;

- Front - In the floor console ahead of the gear lever



- Second Row - In the floor console behind the park brake lever (if equipped)



*personal injuries. Contact an Authorized Mahindra Dealer for any necessary repairs.*

#### WARNING

*To prevent injuries and accidents, secure all electrical appliances before use. Do not use any appliance that may:*

- *Distract the driver while driving, or hamper safe driving*
- *Result in a fire or burn injuries due to the appliance rolling, falling or overheating*
- *Emit steam, while the windows of the passenger compartment are closed*
- *Never use the power outlet for electric heaters while sleeping*
- *Never insert foreign objects into the power outlet*
- *Never use malfunctioning electrical appliances*
- *Never insert inappropriate or badly fitting plugs into the power outlet*

#### CAUTION

*Accessories that draw higher power (i. e., coolers, vacuum cleaners, etc.) will drain the battery quickly and may damage the power outlet.*

#### CAUTION

*Do not modify, disassemble or repair the power outlet in any way. Doing so may result in unexpected malfunction or fire, which could cause serious damage to equipment and/or*





- Use the power outlets only when the engine is running. Remove the plug from the power outlet after using the electric device. Using the power outlets when the engine is OFF or leaving the electric device plugged in for many hours may cause the battery to drain
- Do not use the power outlet to connect electric accessories or equipment that are not designed to operate on 12V
- Some electronic devices can cause electronic interference when plugged into the power outlet. These devices may cause excessive audio noise and may interfere with other electronic systems or devices in your vehicle

## 8.11 Windshield Wipers

### 8.11.1 Wiper Control Stalk

The wipe/wash function can be activated only when the ignition is in "IGN" position.



A	Flick Wipe (MIST)
B	Off
C	Intermittent (INT)
D	Low Speed (LO)
E	High Speed (HI)

### 8.11.2 Wiper Off

The wipe function is OFF when the wipe control stalk is in neutral position (B).

### 8.11.3 Flick-Wipe (Mist)

Push the wipe control stalk to position A for a flick-wipe, hold to operate the wipe continuously (simultaneously lift the wiper stalk



towards the steering wheel to operate the wash). The stalk automatically comes back to position B when released.

### 8.11.4 Intermittent (INT) Mode

Intermittent (INT) wiping is selected when the wipe control stalk is pushed down to position C. In the INT mode, the wiper operates on preset intervals.

The delay between each wipe can be programmed from 1 to 60 sec according to the rain by the user.

Programming of the INT delay time is as follows;

- Turn the wiper stalk to position C, wiper will start wiping
- Turn the wiper stalk to OFF position, before wiper starts second wipe
- Turn the wiper stalk to position C again after the required delay and the same delay will be programmed
- On keeping wiper ON position C, the wiper will wipe again with the programmed delay

### 8.11.5 Low Speed Wiping

Push the wipe control stalk up to the position D to operate the wiper at a fixed low speed.

### 8.11.6 High Speed Wiping

Push the wiper control stalk up to position E to operate the wiper at a fixed high speed.

### 8.11.7 Rear Wiper (if equipped)

Rotate the outer rotary switch (F) on the wiper control stalk to align the 'arrow' on the switch to rear wiper symbol on the wiper stalk to operate the rear wiper.



#### NOTICE

*If you switch OFF the ignition before switching OFF the wiper, the blades stop at random on the windshield. Switch ON the ignition and move wiper stalk to the 'MIST' position to return the wipers to the park position, provided the wiper stalk is in the OFF position.*



### 8.11.8 Wipe/Wash



Pull/Lift the wiper control stalk towards the steering wheel from any position to activate the front wipe/wash function. Washer fluid is sprayed on the front windshield and the wipers wipe the windshield 3 times after the washer spray is stopped and wipe once after 4 sec. Hold the stalk in position for continuous spray of washer fluid.

The rear windshield wash & wipe operates 3 to 4 times or as long as the stalk end is turned/rotated to wash détente. Wiping will continue for few seconds after releasing the stalk end switch.



Washer fluid is taken from the reservoir in the engine compartment.

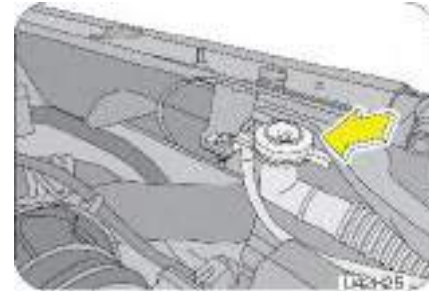

In the front, a single nozzle with twin adjustable washer jets is provided on the applique below the wiper. Using a pin, the eye ball jets can be adjusted precisely for direction. Always direct the washer jet to hit the middle of the windshield. This will enable the wiper blade to wipe the complete width of the windshield.

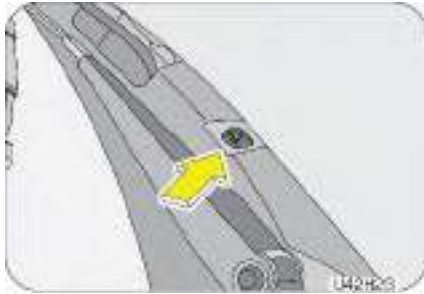

In the rear, a single nozzle with twin adjustable washer jets is provided on the bottom of the rear windshield. Adjust to direct the washer jet to hit the middle of rear windshield using a pin.

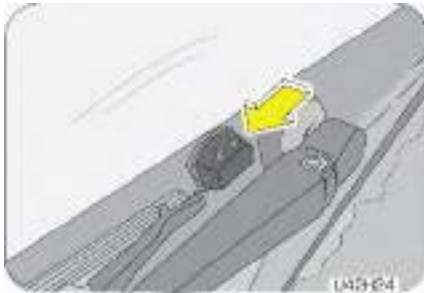

*block your vision, resulting in an accident. If you operate your vehicle in temperatures below 4° C, use washer fluid with antifreeze protection.*

**CAUTION**

- *Do not operate the wipers when the windshield is dry. It may lead to scratches on the glass*
- *It is recommended not to use the wiper when the windshield glass is covered with debris, snow or leaves. Clean the glass before using the wiper to avoid damage to the wiper blades and glass*
- *Do not operate the windshield washer when the reservoir is empty*

**WARNING**

*Using the windshield washer in freezing temperatures could be dangerous. The washer fluid could freeze on the windshield and*



## 8.12 Utility Holders

### 8.12.1 Can/Cup/Bottle Holders (if equipped)

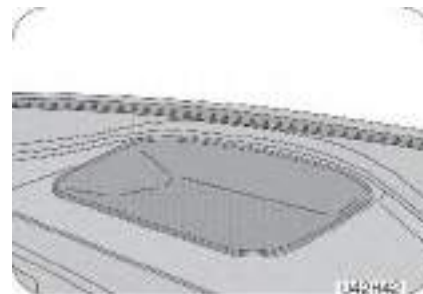
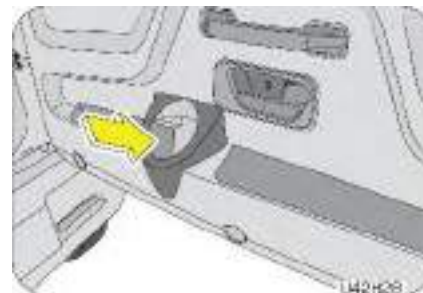
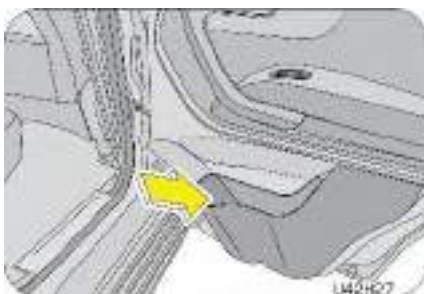

There are cup/can/bottle holders in the front floor console next to the park brake lever, in the front/rear and back door trims. There is also a storage space on the instrument panel above the centre vents for mobiles and other small items.



*Only sealed or cups with lids are to be used in the cup holders.*



*Use caution when using the cup holders. A spilled beverage that is very hot can injure the driver or passengers. Spilled liquids can also damage interior trim and electrical components.*

*Any spilled beverage can also startle the driver and cause loss of control of the vehicle, resulting in an accident.*

*Never place objects other than cups or cans in the cup holder. These objects can be thrown out in the event of a sudden stop or an accident, possibly injuring the passengers in the vehicle.*

### 8.12.2 Glove Box

The instrument panel houses a glove box on the passenger side.

The owner's manual can be found inside the glove box. It is advisable to always keep it in the glove box for ease of reach. It is also recommended to keep copies of all vehicle documents in the glove box for reference when needed. There is also a pen holder inside the glove box for convenience.

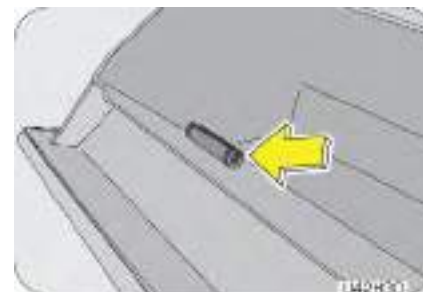
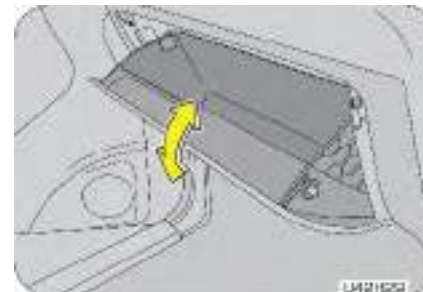

#### NOTICE

*Do not overload the glove box.*

*Do not store loose or small metal objects inside the glove box. This will lead to rattling while the vehicle is driven on bad roads.*



**⚠ WARNING**

To avoid the possibility of injury in case of an accident or a sudden stop, the glove box lid should be kept closed when the vehicle is in motion.

### 8.12.3 Sun Visor

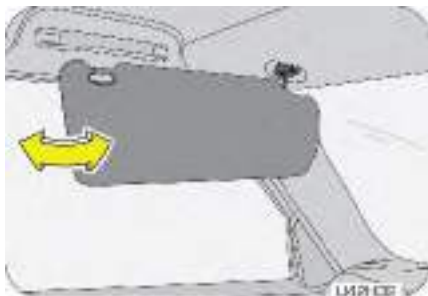

The sun visors can be used for either frontal or sideward shade, to reduce glare or to shut out direct rays of the sun. The sun visor can be swivelled to the side, as shown, to provide shade from the glare of the sun.

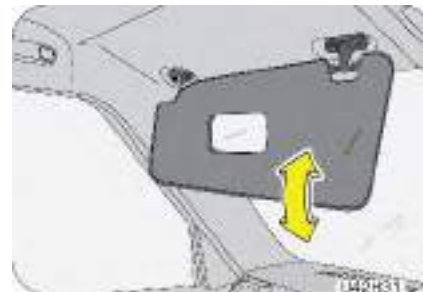

In certain variants, a vanity mirror is provided on the back of the front passenger sun visor.

### 8.13 Horn

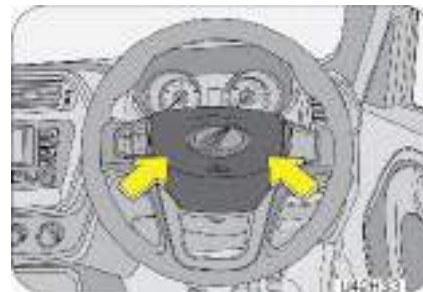

Press the pad on the steering wheel to sound the horn. The horn functions even when the ignition has been switched OFF.



## 8.14 Instrument Cluster



A	Tachometer / RPM Gauge	F	Odometer
B	Warning/Tell tale Lamps	G	Gear Display
C	Speedometer	H	Temperature Gauge
D	Mode Button	I	Trip Meter
E	Fuel Gauge	J	Set Button





## 8.15 Instrument Cluster Gauges

The instrument cluster comprises of the tachometer, speedometer, trip meter (A & B), AC meter, DTE, SET button, MODE button, odometer, fuel gauge, coolant temperature gauge, warning lamps and telltale indicators.

### 8.15.1 Tachometer

The tachometer indicates the real time engine speed in thousands of RPM (revolutions per minute). Maintain steady engine speed below and do not accelerate or decelerate abruptly.



### 8.15.2 Speedometer



The speedometer indicates the real time road surface speed of the vehicle in kilometers per hour.

#### NOTICE

*The vehicle speed is affected by the size of the tires used. If the size of the tires are changed from those fitted at the factory, the speedometer might not display the correct road surface speed and distance travelled.*



### 8.15.3 Odometer



The bottom row of the LCD display gives the odometer reading. It records and displays the total distance traveled in kms.

### 8.15.4 Trip Meter A, B, AC Meter & DTE



The top row of the LCD display gives the details of Trip meter A, B, AC Meter & Distance to empty (DTE) details.

Trip meter A & B displays the distance travelled since the last trip reset.

AC Meter displays the total distance travelled (updated as per the odometer) with the AC ON. When the vehicle is stationary with the AC ON, every minute is taken as 1 km and added to the AC meter reading.

The Distance To Empty is the information in km for the driver to be aware of number of km the vehicle can travel with the available fuel and the fuel economy that the vehicle is giving at that instance. The DTE update will be faster if the refueling quantity is greater than 5 liters.



#### NOTICE

*DTE feature should never be used to calculate the fuel remaining/refilled in the vehicle*

*During air lock, there are chances that the DTE will be showing some value but the engine switches OFF and will not able to crank.*



A Set Button	B Mode Button
--------------	---------------

The trip meters [A/B], & AC meter can be reset to zero by pressing SET [A] button for more than 3 seconds.

**NOTICE**

*Odometer and trip meter are displayed only when the ignition is ON. To cycle between trip A, B, AC meter & DTE press and release MODE [B] button.*

*Pressing the Mode button while in trip A, displays the trip B reading.*

*Again pressing the Mode button displays AC meter reading.*

*Once again pressing the Mode button displays DTE reading.*

### 8.15.5 Gear Selection Display

AMT Display (If Equipped)



Gear selection display displays the shifter position A1, A2, A3, A4, A5.

Manual Display





Gear selection display displays the shifter position in Numerics 1,2,3,4,5.

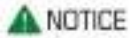

*AC meter is displayed only when the ignition is ON. To cycle between trip A & B and AC meter, press and release MODE [B] button for few seconds.*

### 8.15.6 Temperature Gauge

The engine coolant temperature bar graph functions only when the ignition is switched ON. It indicates the instantaneous engine coolant temperature. The coolant temperature varies with changes in weather, load on engine and driving pattern. LCD bar rises from Cold [C] towards Hot [H].



At normal operating temperature, 4 bars are displayed in the LCD bar graph. The high engine coolant temperature lamp along with all 8 bars blink when the temperature reaches 110 ° C. And when the temperature is 119 ° C, the temperature warning lamp and all 8 bars are permanently ON. In such situations switch OFF the AC and observe any improvements in the temperature gauge. If not, stop the vehicle and allow the engine to cool down. Check the coolant level in the coolant reservoir and top-up if required. If the engine is still overheating, contact your nearest Authorized Mahindra Dealer.



*Never remove the degassing tank cap when the engine is hot. The engine coolant is under pressure and could splash on to skin/eyes causing severe burns. Wait for the engine to cool down before adding coolant to the reservoir.*

*Do not continue driving the vehicle with a overheated engine. This will lead to damage of engine components and engine seizure.*

### 8.15.7 Fuel Level Gauge

The fuel level bar graph functions only when the ignition is switched ON. It gives the status of the fuel level in the fuel tank. F indicates the tank is full (60 liters), E indicates the tank in empty. The amount of fuel required to fill the tank up may be less than the specified tank capacity, as a small amount of reserve fuel always remains in the tank.



When the tank is nearly full, 8 bars illuminate on the LCD bar graph display. When the tank is near empty i.e. RESERVE, the bottom bar alone is illuminated and the low fuel warning lamp in the cluster is ON.



On inclines or curves, due to the movement of fuel in the tank, the fuel level may fluctuate or the low fuel level warning lamp may illuminate earlier than usual and also alert message will come for Low fuel level if equipped with audio system. Always check the fuel level when the vehicle is on level road.

If the low fuel warning lamp continues to be ON even after filling sufficient fuel, contact your Authorized Mahindra Dealer as soon as possible.



*Refuel your vehicle as soon as the last bar illuminates in the fuel bar graph. Refuel your vehicle only after switching OFF the ignition.*



### 8.16 Warning Lamps Overview



To know more about warning & telltale lamps, download the handy “Mahindra TUV300” app from Google playstore or Appstore U42D03



## 8.17 Warning Lamps in the Instrument Cluster

### 8.17.1 Malfunction (OBD) Lamp



The Malfunction (OBD) Lamp illuminates when the ignition is switched ON and remains ON till the engine has started indicating normal status. If the lamp remains ON, it indicates a potential engine malfunction.

There may be a malfunction in:

- The fuel management system
- The emission control system
- Systems which affect emissions

Such malfunctions may result in excessive emissions. Contact an Authorized Mahindra Dealer immediately.

### 8.17.2 Check Engine Lamp



The check engine lamp illuminates when the ignition is switched ON and goes out in 3 seconds indicating normal status. The lamp blinks or illuminates continuously if there is a fault in the engine management system. Contact the nearest Mahindra Dealer for the necessary repairs.

### 8.17.3 Glow Plug Indicator



Glow plug indicator illuminates when the ignition is turned ON. It automatically goes OFF when the glow plug reaches the required temperature. Contact an Authorized Mahindra Dealer if the glow plug lamp does not illuminate with ignition ON or illuminates while driving.

### 8.17.4 Security Lamp



Once the ignition is turned OFF, the security lamp will blink at a fast rate frequency indicating the vehicle is secured against unauthorized start of engine. When the vehicle is locked using RKE, security lamp will blink at a slow rate frequency which will indicate that antitheft system is armed and unauthorized door entry to the vehicle will trigger alarm.

At ignition ON, the security lamp blinking continuously indicates a malfunction in the engine immobilizer system. Contact an Authorized Mahindra Dealer immediately.

### 8.17.5 Parking Brake/Low Brake Fluid/EBD Warning Lamp (if equipped)



The lamp illuminates when the parking brake is engaged or when the brake fluid level in the reservoir is low or when EBD (if equipped) failure is detected. If the lamp illuminates while driving, do the following:



- Check if the parking brake is engaged. If yes, disengage it
- Check if the brake fluid level is low. If yes, top-up brake fluid (DOT 4) to the required level

If the brake lamp still continues to illuminate, immediately get the vehicle checked at an Authorized Mahindra Dealer.



*Clean the top of the brake fluid reservoir before removing the cap. Make sure no dirt, impurities or other items fall into the reservoir. Do not leave the cap off for more than a few minutes. Any contaminants, impurities or moisture in the brake fluid can affect brake operation, resulting in an accident.*

*If the brake warning lamp comes ON while driving, the brake system or the EBD system (if equipped) might not be working properly. The pedal might be harder to operate or might go closer to the floor and it can take longer to stop. Pull off the road carefully and stop the vehicle. Contact the nearest Authorized Mahindra Dealer for checks or repairs.*

*Driving the vehicle with the brake warning lamp ON or when you suspect brake trouble is very dangerous and could result in serious injuries. Contact an Authorized Mahindra Dealer for checks or repairs.*

*When there is a EBD failure, the parking brake lamp illuminates along with the ABS warning lamp.*

### 8.17.6 Turn Lamps



The turn lamp arrows in the instrument cluster flash showing the direction indicated by the turn signals. A sudden increase in the rate of flashing indicates failure of one or more of the lamp bulbs. Have them replaced as soon as possible.

### 8.17.7 Head Lamp High Beam Lamp



The head lamp high beam lamp illuminates whenever the head lamps are switched ON to high beam or when the head lamp flash is used.

### 8.17.8 Battery Charging System Warning Lamp



The battery charging system warning lamp illuminates when the battery is not being charged or when there is a malfunction in the alternator.

This lamp illuminates when the ignition is switched ON and goes out as soon as the engine is started. If the lamp continues to remain ON even after starting the engine, it is an indication that the battery is not being charged or there is a malfunction in the alternator. Check the alternator drive belt for looseness/breakage. If the drive belt is okay, switch OFF all unnecessary electrical equipment and recheck. Contact an Authorized Mahindra Dealer for further assistance.





### 8.17.9 Low Engine Oil Pressure Warning Lamp



The low engine oil pressure warning lamp illuminates when the ignition switch is turned ON and goes out as soon as the engine is started. If the lamp remains ON even after starting the engine, or illuminates while driving, stop immediately and check the oil level after 2-3 minutes. If low, add engine oil to the 'MAX' level and check status. If problem persists, contact an Authorized Mahindra Dealer immediately.



*Operating the vehicle with the low oil pressure warning lamp ON could cause sudden unexpected engine failure and loss of vehicle control, resulting in an accident or personal injury.*

*Do not run the engine with low oil pressure warning indicator ON. This may result in engine damage, which will not be covered by the limited warranty.*

### 8.17.10 High Engine Coolant Temperature Warning Lamp



The high engine coolant temperature warning lamp and all bars in the temp gauge blink when the coolant temperature is 110°C, and they remain permanently ON when the temperature reaches 119°C. Contact an Authorized Mahindra Dealer immediately.



*Do not continue driving the vehicle with an overheated engine. This may result in engine damage, which will not be covered by the warranty.*

### 8.17.11 Water-in-Fuel Warning Lamp



The water-in-fuel warning lamp illuminates when the accumulation of water in the fuel filter reaches the maximum permissible limit. The fuel filter needs to be drained. Contact an Authorized Mahindra Dealer.



*Do not continue driving the vehicle with the water-in-fuel warning lamp ON. This may result in fuel pump/other fuel system component damage, which will not be covered by the limited warranty.*

### 8.17.12 Low Fuel Warning Lamp



When the fuel level in the fuel tank falls below the reserve limit, the low fuel warning lamp is ON. Refuel sufficiently and the lamp goes out. If the lamp continues to be ON even after refueling, contact an Authorized Mahindra Dealer.



### 8.17.13 Seat Belt Warning Lamp



The seat belt warning lamp illuminates reminding the driver to fasten the seat belt when the ignition is ON. The lamp will continue to illuminate till the driver fastens the seat belt properly.

### 8.17.14 Airbag Warning Lamp



The airbag warning lamp in the instrument cluster illuminates when the ignition is switched ON and goes OFF in about 4.5 seconds. If the lamp remains ON continuously or flashes intermittently, contact an Authorized Mahindra Dealer immediately.

Following conditions indicate airbag malfunction:

- Lamp fails to go OFF
- Lamp does not illuminate at all
- Illuminates while driving

Contact an Authorized Mahindra Dealer immediately when the airbag warning lamp indicates a system malfunction. The airbag may not deploy when needed, which could result in serious or fatal injury, or it might deploy unexpectedly and unnecessarily, which may result in personal injury.

### 8.17.15 Anti-lock Brake System (ABS) Malfunction Lamp



The ABS malfunction lamp illuminates when the ignition is switched ON and goes OFF after about seconds. If the ABS malfunction lamp continues to remain ON or illuminates while driving, the ABS will not operate. But the brake system will still operate conventionally. In this condition, the wheels can lock during severe braking. Have the vehicle checked by an Authorized Mahindra Dealer as soon as possible.



**WARNING**

*When a EBD failure is detected, both the ABS and the parking brake warning lamps illuminate.*

### 8.17.16 Front Fog Lamp



The front fog lamp telltale indicates the status of the front fog lamp. The front fog lamp can be switched ON only when the parking lamp is ON.

### 8.17.17 Door Ajar Warning Lamp



The door ajar warning lamp illuminates when any door is open when the ignition is ON. The lamp goes OFF when all the doors are closed properly.



### 8.17.18 Start/Stop Lamp (Micro Hybrid)



The Start/Stop lamp blinks when the engine is about to be stopped by Start/Stop System. And the lamp turns ON continuously when the engine has been switched OFF by the System. On restarting engine by pressing the clutch/key, the lamp turns off.

The Start/Stop lamp blinks at faster rate for a longer time than usual when the battery state does not allow the system to stop the engine automatically.

### 8.17.19 AMT warning Lamp



The AMT warning lamp illuminates when the ignition switch is turned ON and goes out as soon as the engine is started. If the lamp remains ON even after starting the engine, or illuminates while driving, there is a possibility of malfunction in AMT system. Contact an Authorized Mahindra Dealer immediately.

### 8.17.20 ECO Lamp ( if equipped)



Whenever ECO switch is pressed in vehicle the ECO lamp will turn ON in Cluster and it will indicate that the vehicle is running in economy mode. If ECO switch

is pressed but still ECO lamp is not turning ON or without pressing ECO switch if ECO lamp is ON, contact an authorized Mahindra dealer immediately.

### 8.18 Voice Messaging System(VMS) (If equipped)

A state-of-the-art system, the Voice Messaging System (VMS) is provided to monitor and announce various warnings in your vehicle. This is in addition to the warnings on the instrument cluster. VMS is a unique gadget, which provides security to you and your vehicle. It monitors specific fault signals from your vehicle.

### 8.19 Mike(If equipped)

Mike is located in the roof panel near the Roof lamp. It receives the voice and transmits during the mobile is connected through Bluetooth.





## 8.20 Reverse Parking Assist System (RPAS)[If equipped]

Reverse parking assistance system is provided to aid the driver while parking the vehicle in reverse at a speed of less than 5 kmph. While reversing, RPAS will detect the obstacles at the rear side of the vehicle within the sensing zone, which cannot be viewed through the internal rear view mirror and the outside rear view mirrors. The RPAS will then alert the driver by a beep sound about the location of the detected obstacle and the distance from the vehicle. The alert sound level will vary proportional to the distance. Smaller the distance shorter the interval between the beeps.

Four RPAS sensors are located at the rear bumper to provide complete rear view to the driver for hassle free parking.



*Magnetic devices present in the detection range could vastly affect the sensor performance and the distance displayed may not be accurate.*

### 8.20.1 Working Principle

- On engaging the gear in reverse, the RPAS system gets activated automatically and the vehicle image appears in the infotainment screen. Display bars below the car image indicate the obstacles behind the vehicle

- When the obstacle comes in the sensing zone, the system starts giving the indication based on the distance and direction of the obstacle as defined in the detecting zones. The closer the obstacle, more display bars are illuminated

#### RPAS Information on Infotainment Screen



RPAS display on the infotainment screen gives the following information:

- Left zone indicates obstacle on the left hand side
- Center zone indicates obstacle in the center
- Right zone indicates obstacle on the right hand side

Display bars 1, 2, 3 and 4 indicate how close the obstacle distance is from the vehicle rear bumper, with bar 1 being very close and bar 4 being distant. The infotainment screen display's a STOP! symbol if the obstacle is less than 50 cm from the vehicle rear bumper.



**Operation of RPAS**

1. Start the vehicle (IGN is turned ON)
2. Change the gear to reverse (engage the reverse gear). The RPAS will be displayed on the infotainment screen.



3. Start moving the vehicle in the reverse direction
4. Display bars in the respective direction will glow according to obstacles in its path
  - If the obstacle is between 100 to 120 cm, bar 4 will be turned ON





- If the obstacle is between 75 to 100 cm, bar 3 & 4 will be turned ON



- If the obstacle is between 50 to 75 cm, bar 2, 3 & 4 will be turned ON



- If the obstacle is less than 50 cm, all bars in that direction will be turned ON and a STOP! symbol will be displayed



5. The alert sound can be heard from the driver and co-driver side speaker. Frequency of the beep will increase if obstacles comes closer (crossing each display bar) and the sound will be continuous if any of the obstacle is less than 50 cm
6. The RPAS distance displayed will be the minimum of distances sensed by left, center and right sensors. For eg. Assume 3 obstacles are placed as below;
  - Obstacle at left at 60 cm
  - Obstacle at center at 90 cm
  - Obstacle at right at 110 cm

On engaging the gear in reverse, infotainment will display as below. Along with this, a beep sound can be heard from the driver & co-driver speakers. Frequency of the beep will increase if the obstacle comes closer (crossing each zones) and the sound will be continuous if any of the obstacles is less than 50 cm.



**WARNING**

If the display bars in any one/all of the sides are displayed with cross marks, contact the nearest Authorized Mahindra Dealer.



**NOTICE**

The distance indicator will display the distance in multiples of 2 cm, whichever is shortest

**NOTICE**

- System cannot sense wire mesh, handrail, small objects and some obstacles which come below the bumper level
- System cannot sense obstacles like cotton or spongy surfaces which absorb ultrasonic waves
- System performance is dependent on the reflection angle of the obstacle
- System may not detect obstacles up to 40 cm from the bumper by virtue of system design



- System may give wrong signal when any extra material is wrapped around the spare wheel or if there are any protrusions from the spare wheel
- System may give a wrong signal (or detect the wheel as an obstacle) if the spare wheel/cover mounting is incorrect, hanging or misaligned. Ensure the spare wheel and wheel cover are intact and rigidly fitted
- System may give a wrong signal on reversing the vehicle on grasslands and bumpy roads
- System may give a wrong signal while the vehicle is moving from plain ground to sloping ground or vice versa
- System may give a wrong signal by sensing the ground when the bumper is tilted more from the normal position or when the vehicle is heavily overloaded
- System may give a false alarm during heavy rain, windy or snowy conditions
- Clean the sensors and ensure they are free of ice, dust, water, etc. for proper working of the system
- System will not work properly if the sensor orientation is changed
- The distance of the obstacle displayed is from the rear bumper
- System will not sense pot holes or trenches or drains which are below ground level
- Any sort of paint or any adhesive on the sensor faces will not guarantee the proper functioning of the system
- Applying pressure on the sensor face may deteriorate system performance, so care should be taken while replacing sensors. In the event, the sensors are found damaged don't attempt to replace them by yourself, bring them to the notice of your dealer
- Bumper covered with guards and other accessories may not allow sensors to function properly
- Not all obstacles are detected from 120 cm, for instance, a person is detected from 75 cm because of weak reflection or absorption of the waves of clothes
- The distance indication may move up and down due to different sizes of obstacles at different positions
- Though the obstacle is in the sensing zone, the obstacle may not be detected in certain cases if the ultrasonic waves are not reflected back to the sensor
- While braking/decelerating, energy is transferred from wheels to battery **For auto stop to happen the following major conditions are to be met**

**NOTICE**

RPAS is an aiding system. Under no circumstances will Mahindra accept any responsibility or can be held liable for any





*direct or indirect, incidental or consequential damage caused by this system.*

## 8.21 Brake Energy Regeneration Technology(If equipped)

In “**Brake Energy Regeneration**” technology additional electrical energy is generated through Alternator during braking / decelerating and preserved in the battery. This optimisation process of electrical energy generation leads to reduced fuel consumption and emission. Also, during accelerations, generation process is disabled which reduces load on the engine leading to improvement in vehicle performance. The system architecture is equipped with battery management sensor (patented by Mahindra) and an intelligent alternator which ensures optimal electrical energy management as an additional benefit

### 8.21.1 How Does the system Work?

**While braking/decelerating, energy is transferred from wheels to battery**

- For auto stop to happen the following major conditions are to be met

**While accelerating, the alternator is disabled and the energy is available to wheels**

- When the vehicle is accelerating for example, while overtaking, alternator will be electrically disabled and load on the engine reduces which helps to accelerate little faster

### 8.21.2 Frequently Asked Questions (FAQ)

1. What is the advantage of this system?

The “Brake Energy Regeneration” system helps in attaining better fuel efficiency on your vehicle as you drive and thus reduces your running costs. The fuel efficiency improvement depends on various parameters of your driving pattern and vehicle conditions

2. What are the other advantages of this system?

- It improves the vehicle performance during acceleration
- It improves the battery life by proper battery conditioning
- No need to perform any additional actions towards the benefits - the system works as you drive your vehicle

3. What are the additional parts of the system?

The system consists of

- Battery Management Sensor (BMS)
- Intelligent Alternator
- Headlamp PWM Modules

4. What is the function of Intelligent Alternator?

The Intelligent Alternator is the one which responds to the commands of BMS and generates energy accordingly

5. What is the function of Headlamp PWM module?



The Headlamp PWM module suppresses any voltage spikes and provide the operational voltage to the Headlamps

6. What if any of the part fails?

If the Battery Management Sensor fail / communication gets disturbed, there are redundant functionalities integrated into the system towards charging the battery.

7. How do I know whether the system is working?

The BCC lamp will go OFF once the engine is cranked as in the normal case. If there is any problem in the system, a DTC will be set which can be accessed by our Service Engineer.

8. During vehicle acceleration, alternator generation is disabled. What about the vehicle electrical loads?

During that momentary duration, all electrical loads will be supported by the battery.



## 8.22 Micro Hybrid Technology (Engine Stop/Start System, ESS)[If equipped]

### 8.22.1 Overview of the System

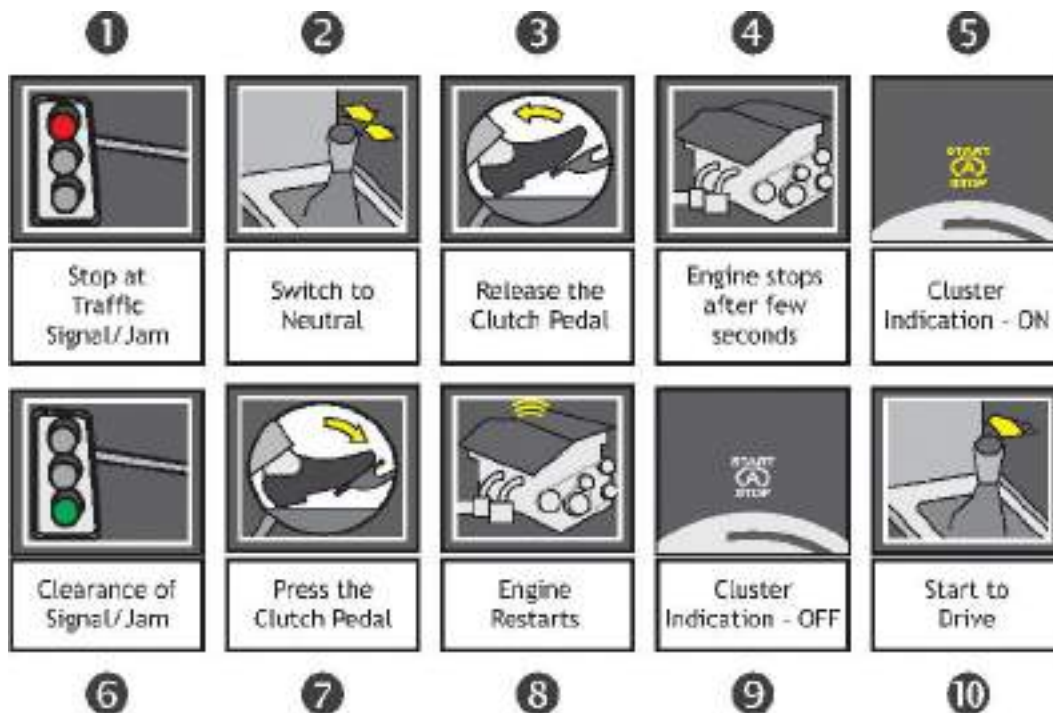



## 8.22.2 How Does the ESS Work?

Let's take a simple example of driving in traffic conditions within your city. Assume that your vehicle has stopped at a traffic junction due to a red signal. The following steps illustrate how the system functions.

- The vehicle has come to a halt at a traffic signal, is in the neutral gear and the clutch pedal is released
- The 'ESS' lamp in the cluster will blink indicating that the engine is going to stop shortly. The engine will shut down automatically after a specific time period

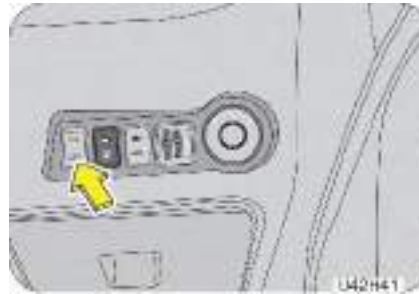

- The 'ESS' lamp will illuminate in the instrument cluster indicating the engine was stopped by the ESS system.
- Once the signal turns green, press the clutch pedal and the engine starts immediately
- The indicator in the cluster goes OFF indicating that the engine has started again and you are ready to drive on

**For auto stop to happen the following major conditions are to be met**

- ESS system is activated using the selection switch
- Bonnet is fully closed



- In the current ignition cycle, the vehicle has crossed 2 kmph at least once
- Current status of the engine is idling
- Vehicle speed is zero
- Accelerator pedal and clutch pedal are fully released
- Vehicle battery should be in healthy condition
- Engine is warm. This is an extra precaution to ensure safe working of the engine
- Gear is in neutral

**For auto start to happen the following major conditions are to be**

- Vehicle should have been stopped by the ESS system
- Gear lever is in the neutral position
- Vehicle speed is zero
- ESS switch is in active mode
- Bonnet should be closed
- Clutch pedal is fully pressed (to restart)

### **8.22.3 Frequently Asked Questions (FAQ)**

1. What is the advantage of this system?

The ESS system aids in attaining better fuel efficiency of your vehicle and thus reducing your running costs. However, the mileage improvement will depend upon various parameters such as prevailing traffic, driving patterns, etc.



2. What are the other advantages of this system?

- Since the engine is switched off during traffic signals/ jams, considerable amount of carbon dioxide release to the atmosphere is avoided. This reduces global warming and thus provides us with a sustainable planet to live in.
- Ability to restart the engine by pressing the clutch pedal
- Reduces noise pollution at traffic signals

3. Is it possible to start the engine through the clutch pedal for the first time?

No, the engine can be cranked only with the ignition key for the first time. If the engine is stopped automatically by the system, only then it is possible to start the engine through the clutch

4. Whether the system will get activated as soon as the engine is started the first time with the ignition key?

The system will get activated only after the completion of engine temperature dependent warm up period which may extend up to 15 minutes. This is to ensure better performance of the engine in terms of fuel economy and durability.

5. Are there any safety precautions to be followed?

Yes, when the engine is turned OFF at traffic signals/ jams with heavy electrical loads like head lamp or AC switched 'ON'. If the duration of such stops are long, it is recommended to keep the engine 'ON' and the ESS system in 'OFF' position.

6. What is to be done, if I don't want the system to stop my engine at traffic signals/ jams?

The system can be turned OFF by switching OFF the Stop/ Start selection switch.

7. Whether the A/C will function, if the engine is switched off?

No, the A/C will not work. However the blower will be in operation when the ignition is ON.

8. What will happen if I keep the clutch continuously pressed at traffic signals/ jams?

The system will not stop the engine if the clutch is continuously pressed since it indicates the driver's intention of moving the vehicle immediately.



9. When the battery charge is low, whether the engine will be switched off?  
If the battery charge drops below a certain level, the system will not stop the engine so as to preserve the battery from further draining.
10. Whether I will be able to operate the engine with the normal ignition key?  
Yes, normal operation with the ignition key is always possible.
11. Whether the vehicle will start [or] stop in gear?  
The vehicle will not start or stop automatically in gear to ensure safety. It will do so only in the neutral position of the gear shift lever.
12. Whether the system will stop my engine in moving traffic?  
No, the engine will be stopped only when the vehicle speed is zero continuously for more than 2 sec.
13. Whether the audio system will be switched OFF, when the engine shuts down?  
No, the audio system will not be switched OFF and you can continue to enjoy the music.
14. Whether the engine will re-crank whenever the clutch pedal is pressed?  
No, when the engine is running, the starter motor will not attempt to re-crank.
15. If any component involved in the system fails, what will happen?  
The system has a built-in diagnostic module which understands the failure and immediately goes to bypass mode. In the bypass mode the engine can be turned ON and OFF with ignition key as usual.
16. Are there any indications to show that engine does not stop due to poor battery charge state?  
Yes, if all other conditions except battery charge are met, the ESS lamp blinks faster for 7.5 seconds and the engine does not switch OFF.



## 8.23 Radio Frequency ID (RFID) Tag

Your vehicle is fitted with a RFID tag as per CMVR regulations on front windshield.

RFID tag may be used for Electronic Toll Collection (ETC).

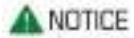

*Do not peel or remove the RFID.*







## 9 STEERING AND BRAKES

### 9.1 Steering

Your vehicle is equipped with power steering. Power steering uses energy from the engine to decrease the driver's effort in steering the vehicle. The power steering system will give you good vehicle response and increased ease of maneuverability in tight spaces. If for some reason the power assist is interrupted, it will provide mechanical steering capability to steer the vehicle. Under these conditions, you will observe a substantial increase in steering effort, especially at very low vehicle speeds and during parking maneuvers.

#### NOTICE

*Upon initial start-up in cold weather, the power steering pump may produce noise for a short amount of time. This is due to the cold, thick fluid in the steering system. This noise should be considered normal, and it does not in any way damage the steering system.*

#### WARNING

*Continued operation with reduced power steering performance could pose a safety risk to yourself and others. Have the vehicle serviced at specified intervals or whenever a power steering problem is noticed.*

*When driving in rough/off roads, hold the steering wheel rim, do not hold the wheel spokes. A sudden bump can jerk/ turn*

*the wheel and injure your hand. This may also lead to loss of vehicle control.*

#### NOTICE

*Keep both hands on the steering wheel, with the thumbs resting on the outer wheel rim.*

To help prevent damage to the power steering pump:

- Never hold the steering wheel to the extreme right or the extreme left for more than a few seconds when the engine is running
- Heavy or uneven steering efforts may be caused by low power steering pump fluid level. Check the low power steering pump fluid level before seeking service from an Authorized Mahindra Dealer
- Do not fill the power steering pump reservoir above the MAX mark on the reservoir, this may result in leaks from the reservoir

#### NOTICE

*If the power steering system breaks down (or if the engine is turned OFF), you can still steer the vehicle manually, but it takes more effort.*

If the steering wanders or pulls, check for:

- Under inflated tire(s) on any wheel(s)
- Uneven vehicle loading



- High crown in the center of the road
- High crosswinds
- Wheels out of alignment
- Wheels out of balance
- Loose or worn suspension components

## 9.2 Tilt Steering



The steering wheel can be adjusted for rake as required using the lever in the steering shroud under the steering wheel.

To tilt/adjust the steering wheel;

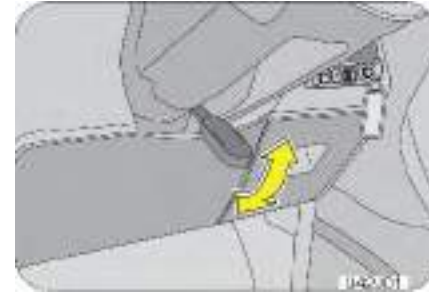

1. Ensure the vehicle is stationary and parking brake engaged
2. Pull the steering tilt lever down to unlock
3. Raise or lower the steering wheel to the desired position
4. Push the lever back up to its original position to lock the steering
5. Adjust the seat according to the steering wheel position

### WARNING

*An improperly locked steering wheel could cause loss of control and lead to accidents. Never adjust the steering wheel while driving.*

## 9.3 Steering Controls - Audio Control System (if equipped)

Audio control through the steering wheel switches/buttons helps the driver to operate the audio system from the steering wheel



without losing concentration. The system has four switches which are mounted on the steering wheel. Hold the Mute button to start the infotainment



### NOTICE

Refer to the Audio/Infotainment Manual for complete information on audio controls and features. The map upgradation details are also available in the Infotainment manual.



A	Source	C	Mute
B	Seek/Call Receive /Disconnect	D	Volume [+] & Volume [-]

#### Source

The source button switches between different modes in the audio system.

When the source button is pressed once, the next source is chosen in the following sequence, provided the required media is connected.

Tuner ⇌ MP3 ⇌ USB - Auxiliary

In case of the absence of USB mode, the system will toggle between Tuner and Auxiliary modes.

#### Seek/Call Receive/Call Disconnect



Press the SEEK switch once to increase radio reception frequency by 0.05 MHz. Press the SEEK switch continuously for more than 3 Sec for AUTO scan of radio stations. In USB modes, the next track can be selected by pressing the switch once.

This button can also be used to receive or disconnect calls while connected through Bluetooth.

#### Mute

Press the Mute button to mute the audio. Press again to Un-mute.

#### Volume (+) and Volume (–)

To increase the volume by one point press the (+) button once. To decrease the volume by one point press the (–) button once.



#### NOTICE

*If the steering wheel audio control switches do not work, you can still control the system through the infotainment system or with the remote (if equipped).*

## 9.4 Brakes

Your vehicle is equipped with disc brakes in the front and drum brakes in the rear.

Disc brakes offer good braking capability and reduced stopping distance. Wet brake discs result in reduced braking efficiency. After a car wash or driving the vehicle through water, dab the brake

pedal while driving to remove the film of water from the brake pads. Brake pads feature wear indicator. When the brake pad is worn, metallic squeal noise is heard indicating the pad wear. Have them replaced immediately.



#### WARNING

*Driving with wet brakes is dangerous. Stopping distance increases considerably when braking.*

*Dry the brakes by driving at very slow speed and applying the brakes lightly until the brake performance becomes normal.*



#### CAUTION

*Even if the power assist (vacuum assistance) is completely lost, the brakes will still work. The brake pedal would be much harder than normal and the vehicle stopping / braking distance will be longer than usual.*

### 9.4.1 Parking on a Hill/Incline

If you have to park facing uphill, select first gear and turn the front wheels away from the kerb. If you have to park facing downhill, select reverse gear and turn the front wheels towards the kerb. Always ensure the parking brake is engaged before leaving the vehicle.



## 9.4.2 Parking Brake



To apply the parking brake, pull the park brake lever up as firmly as possible. When the parking brake is applied with the ignition ON, the brake warning lamp in the instrument cluster illuminates. To release the parking brake, pull the parking brake lever up slightly, press the release button on the lever tip and lower the parking brake lever completely.

### NOTICE

*The brake warning lamp indicates only the parking brake status. It does not indicate the degree of brake application. Be sure the parking brake is firmly set when parked and the gear shift lever is in gear. When parking on a hill you should apply the parking brake before placing the shift lever gear, since the load on the transmission locking mechanism may make it difficult to move the shift lever out of gear.*

### CAUTION

*Be sure the parking brake is fully disengaged before driving off. Failure to do so can lead to brake problems due to excessive heating of the rear brakes.*

- *The parking brake should be adjusted as per recommended maintenance schedule*
- *Always apply the parking brake when leaving the vehicle, and be certain to leave the transmission in gear. Failure to do so may allow the vehicle to roll and cause damage, hit a bystander resulting in personal injury.*
- *Leaving unattended children in a vehicle is dangerous for a number of reasons. Children should be warned not to touch the parking brake or the gear shift lever. Do not leave the key in the ignition. A child could move the vehicle leading to accidents*
- *The parking brake should always be applied when the driver is not in the vehicle.*

Engaging the parking brake while the vehicle is in motion can cause the rear wheels to lock up. You could lose control of the vehicle and cause an accident.



## 9.5 Anti-Lock Brake System (ABS) (if equipped)

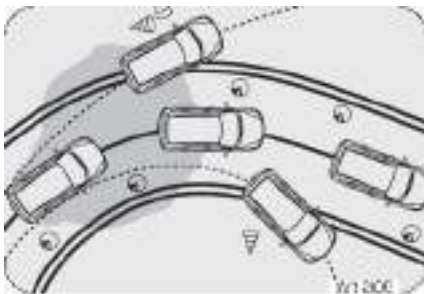

The Anti-lock Brake System (also called as ABS) is designed to help prevent lock-up of the wheels and stable stopping of vehicle during a sudden, panic emergency braking or braking on slippery road surfaces. The ABS system takes input from wheel speed sensors and brake pedal switch to control the brake fluid pressures at the wheels to avoid wheel lock-up. It allows vehicle to be steered during braking.

The minimum speed for ABS to function is 12 kmph. ABS is activated only during wheel lock conditions where ABS takes over and prevents wheel lock. During the ABS operation, a slight pulsation may be felt in the brake pedal to indicate ABS is active. You may also hear motor noise from the engine compartment. It is recommended to hold the brake pedal firmly while the ABS is active rather than pumping the brake pedal.

Depressing the brake pedal on slippery road surfaces as on a manhole cover, a steel plate at a construction site, a joint in a bridge, etc. on a rainy day, tends to activate the anti-lock brake system. The ABS warning lamp lights up when you switch ON the ignition and should go out after a few seconds. If the ABS warning lamp does not go out or if it comes ON while driving, it means there is a fault in the ABS system. In both cases, the normal braking system remains efficient, exactly as on a vehicle without ABS.

The vehicle should be examined as soon as possible by an authorized Mahindra dealer. The Anti-lock brake system is not designed to shorten the stopping distance: Always drive at a moderate speed and maintain a safe distance from the vehicle in front of you. The stopping distance may be longer in the following cases:

- Driving on rough, gravel or snow covered roads.
- Driving with tyre chains installed.
- Driving over steps such as the joints on the road.
- Driving on roads where the road surface is pitted or differences in surface height.



The ABS warning lamp lights up when you switch ON the ignition and should go out after a few seconds. If the ABS warning lamp does not go out or if it comes ON while driving, it means there is a fault in the ABS system. In both cases, the normal braking system remains efficient, exactly as on a vehicle without ABS. The vehicle



should be examined as soon as possible by an authorized Mahindra dealer.

 **WARNING**

*Do not overestimate the Anti-lock Brake System: Although the Anti-lock Brake System assists in providing vehicle control, it is still important to drive with all due care and maintain a moderate speed and safe distance from the vehicle in front of you. There are limits to the vehicle stability and effectiveness of steering wheel operation even with ABS active. If tyre grip performance exceeds its capability, or if hydroplaning occurs during high speed driving in the rain, the Anti-lock Brake System will not assist with vehicle control.*







## 10 HEATING, VENTILATION AND AIR-CONDITIONING SYSTEM (HVAC)

The climate control system enables you to set the cabin at the desired comfortable condition by controlling airflow, air intake and temperature control. The HVAC system also helps in defrosting and defogging/ de-misting the windshield and windows.

Engine coolant is utilized to heat the cabin air. For cooling cabin air, an air conditioning circuit based on the vapor compression refrigeration cycle is used. The air conditioning system uses a refrigerant along with a suitable lubricating oil. Although being non-ozone depleting, the refrigerant is a greenhouse gas, hence once allowed to escape in the atmosphere, it adversely affects the environment by contributing to global warming/ climate change.

Multiple vents are provided for distributing the air, being force circulated by the HVAC blower, throughout the passenger compartment. Various ducts supply air from the HVAC unit to these vents having adjustable louvers.

### WARNING

*Refrigerant used in the system is a hazardous liquefied gas and is under high pressure. The refrigerant is colorless and has ethereal or faint sweetish odor. Exposure of refrigerant to the skin or eyes may cause irritation and frostbite. It can also cause suffocation, dizziness and loss of concentration. When mixed with compressed air or certain other refrigerants, it may form a flammable mixture. Never try to service the HVAC system yourself which would involve refrigerant handling.*

### NOTICE

*To ensure sufficient air flow and hence adequate HVAC system performance, the air flow path should be kept free of obstructions. Keep the system's air intake, located near the plenum appliqué, free of snow, leaves and other debris. Also keep the area in front of the air vents free of any obstruction inside the cabin.*



## 10.1 HVAC Overview

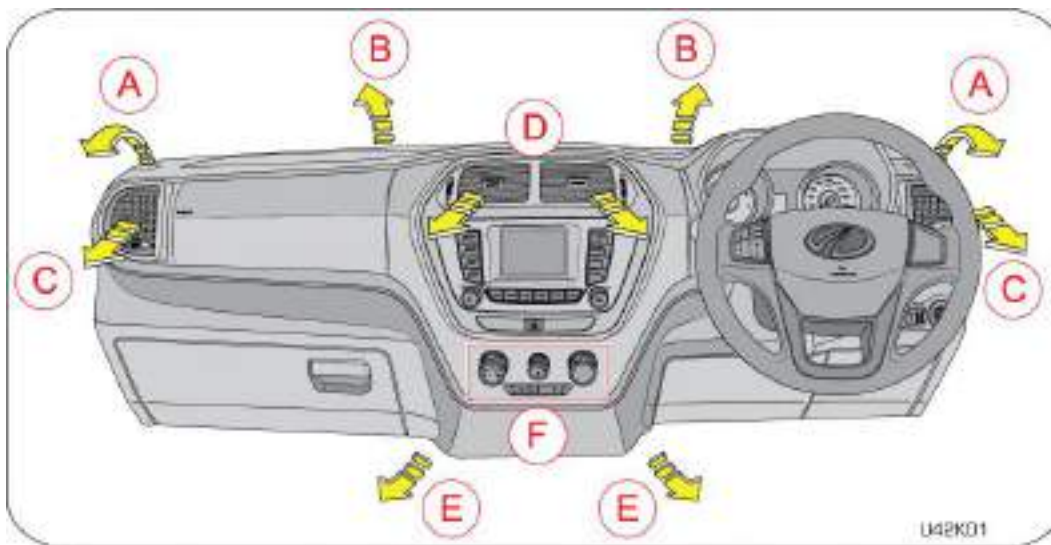

A	Side De-misting Vents	D	Center Vents
B	Windshield Defrost Vents	E	Foot Vents
C	Side Vents	F	HVAC Controls



## 10.2 Center/Side Vents

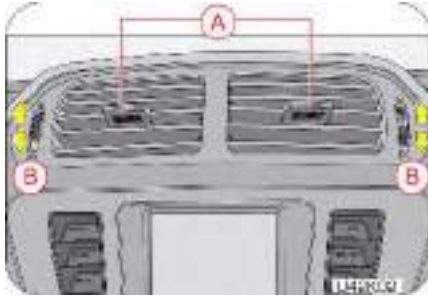

A	Adjustable Louvers
B	Thumb Wheel (Open/Close)

Two center vents are located above the audio system on the instrument panel. Both the center and side vents provide air flow to the front seat passengers. Rotate the thumb wheel (B) up to open or down to close the air vent. Direct air to the desired direction by the adjusting louvers (A).

There are two side vents located one each at the left and right extreme ends of the instrument panel.



Rotate the thumb wheel right to open or left to close the air vent. Direct air to the desired direction by the adjusting louvers (A).

## 10.3 HVAC Controls





A	Air Distribution Control	D	AC ON/OFF
B	Blower Speed Control	E	AC ECO Mode
C	Temperature Control	F	Air Re-circulation Switch

## 10.4 Air Distribution Control

The air flowing out of various vents can be controlled by the air distribution control knob/button.

Following are the five different distribution modes to choose from:

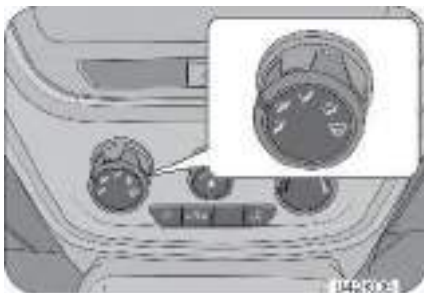

- Face Mode — air is discharged from the center vents and side vents. This mode is most suitable for directing air flow towards the face of the passengers

- Face-Foot Mode — air is discharged from the center vents, side vents and foot vents. This mode is most suitable for directing air flow towards both the face and feet of passengers at the same time
- Foot Mode — air is discharged from the two foot vents. This mode is most suitable for directing air flow towards the feet of passengers seated on front seats
- Foot-Defrost Mode — air is discharged from the foot vents, side defrost vents and windshield defrost vents. This mode is most suitable for directing air flow towards the feet of passengers while defrosting or de-misting/defogging. Keep the air intake knob in fresh air mode
- Defrost Mode — air is discharged from the side defrost vents and windshield defrost vents. This mode is most suitable for directing air flow towards the front windshield to ensure defrosting or de-misting / defogging. Keep the air intake knob in fresh air mode



## 10.5 Blower Speed Control

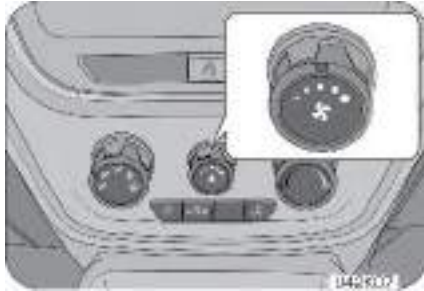

The blower force-circulates air through the HVAC unit and distributes it throughout the passenger compartment.

Blower is off when the blower speed control knob is set to small "o" position (extreme left). To switch-on the blower, rotate the control knob clockwise which progressively increases the blower speed.

## 10.6 Temperature Control

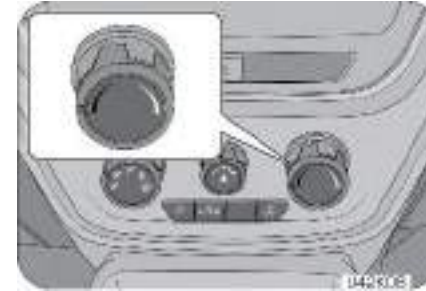

By operating the temperature control knob, temperature of air being discharged from various vents can be adjusted to the desired level. Engine coolant is utilized to heat, whereas the air conditioner is used to cool the air inside the AC unit. Based upon selected position of the temperature control dial, the desired discharged air temperature can be obtained.

By rotating the dial counter-clockwise and setting it to the extreme left position, maximum cooling is obtained. When the dial is rotated clockwise, the discharged air progressively starts getting warmer and at the extreme right position, hot air is discharged.



### NOTICE

*'-' represents cooling and '+' represents heating.*



## 10.7 Air Intake Mode Control

The air intake control button toggles between fresh air or recirculated air modes.



### Fresh Air Mode (Outside Air Mode)

To set the HVAC system to fresh air mode, keep the air intake control switch in the OFF condition. The lamp on this switch is OFF, indicating that the fresh air mode is active. In this mode, fresh air from outside the vehicle is sucked by the blower and utilized further to ventilate/cool/heat the cabin.

### Re-circulation Mode (Re-circulated Air Mode)

To set the HVAC system to re-circulation mode, press the air intake control switch once. The lamp on the switch is ON, indicating that re-circulation mode is active.

In this mode, the air from inside the passenger compartment will be sucked by the blower and utilized further to ventilate/cool/heat the cabin.

For quick cabin cooling/heating or while driving through dusty/polluted regions, the recirculation mode can be selected. Driving with this mode active may lead to better fuel economy and longer HVAC filter life.

However, running the air conditioner in the re-circulation mode for long will make the cabin air too dry and the oxygen level drops inside cabin turning the air stale. On the contrary, keeping air intake control in the recirculation mode for long, with the air conditioner switched OFF, will make the cabin air too humid and the windshield/windows are more likely to fog.

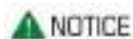

### NOTICE

*The re-circulation mode is activated by default every ignition cycle.*

## 10.8 Air-Conditioner ON

The air conditioning system can be switched ON/OFF by the “AC button” in the climate control system. A LED is also incorporated on the button to indicate the status. The air conditioner is operational only when both the engine and blower are running.

When the air conditioner is ON, air gets cooled and de-humidified before being circulated inside the cabin. In hot weather conditions, it



will take slightly longer to cool the interior as compared to cooler weather. Fuel consumption will be relatively higher if the vehicle is being driven with the air conditioner.

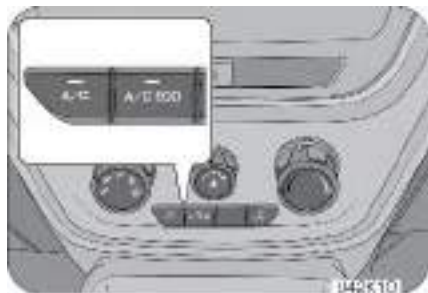

The following steps outline the procedure to switch ON the AC;

1. Adjust the blower speed as required.
2. Select the air distribution mode as desired.
3. Select the air re-circulation mode if required.
4. Press the AC button to turn on the AC.
5. Adjust the temperature control dial as per the temperature requirement.

#### NOTICE

- *In certain operating conditions when the engine gets overheated, the engine management system may switch off the air conditioner intermittently*

- *Occasionally the air conditioner might not actually be functioning even when the LED on the AC switch remains illuminated. This is to be considered as normal AC system operation*
- *During extreme cold weather conditions, the air conditioner may not function until the temperature of the air near the evaporator rises above a pre-defined threshold*
- *When the air conditioner is ON, moisture is extracted from the air. The resulting condensate is drained off from the vehicle. It is therefore normal, if you see a small pool of water under your vehicle*
- *The air conditioner should be operated at least for ten minutes once every fortnight, even during winter months. This allows the AC system components to get lubricated periodically and ensures optimum system performance*

#### NOTICE

*Your vehicle is equipped with an HVAC filter. If the AC performance is considerably low, it is recommended have the HVAC filter checked at the nearest Mahindra Dealer.*

### 10.9 HVAC Air Filter (Cabin Air Filter)

Your vehicle's HVAC system is equipped with an air filter at the blower inlet just behind the glove box. Before getting sucked-in by the blower, air passes through this filter element. Dirt and other





foreign particles get trapped inside the filter. Clean air is then circulated through the HVAC unit and into the cabin.

The HVAC filter gets clogged after long use. The clogged filter will reduce the air flow rate, thereby the air-conditioning and heating efficiencies will be drastically reduced. Even the windshield/windows may begin to mist/fog-up easily.

To maintain optimum HVAC system performance, clean the filter element as per recommended maintenance schedule. However while operating in highly dusty or polluting conditions, the filter may require early replacement. If the air flow seems to have considerably reduced, get the filter cleaned immediately.

To access the filter, open the glove box, remove the rubber pins on both sides of the glove box lid. Un-clip the filter retaining clip and remove the filter straight out. Clean the air filter or replace (if damaged) and follow the reverse procedure for putting the filter back.



*Never operate the HVAC system with the filter removed. This may result in premature failure of system components.*

## 10.10 Rapid Cabin Cooling

For rapid cooling of the cabin, the following AC settings are recommended:

1. Make sure that all the windows are fully closed
2. Set the blower to maximum speed
3. Fully open the vents and adjust louvers to direct air toward face
4. Set the air distribution control to face mode
5. Set air intake control to recirculation mode
6. Turn the air conditioner ON
7. Set the temperature control knob to the extreme left (coolest) position

Once the passenger compartment reaches a comfortable temperature, shift to fresh air mode. Also blower speed and temperature control knob can be re-adjusted as desired.

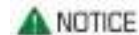

*If your vehicle was parked in the hot sun with all the windows closed, drive the vehicle with windows open for the first few minutes. This will help in venting the hot interior air out and allow the air conditioner to cool the cabin quickly.*

## 10.11 Rapid Cabin Heating

For rapid heating of the cabin, the following AC settings are recommended:

1. Make sure that all the windows are fully closed



2. Set the blower to maximum speed
3. Set the air distribution control to foot mode
4. Set air intake control to recirculation mode
5. Set the temperature control knob to extreme right (hot) position
6. For dehumidified heating, switch the air conditioner ON

Once the passenger compartment reaches a comfortable temperature, the blower speed and temperature control knob can be readjusted as desired.

#### NOTICE

*In extreme cold weather conditions, the engine coolant takes time to get heated up. Hence it might take a while for hot air to discharge.*

## 10.12 Defogging/De-misting and Defrosting

For keeping the front windshield and side windows clear, proper control of the HVAC system is essential. Follow the instructions in the subsequent sections to clear the frosted/misted/ fogged up front windshield.

### 10.12.1 Front Windshield Defog

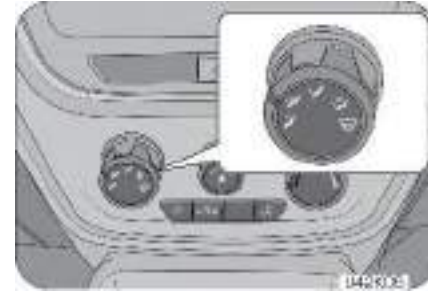

1. Set the blower to full speed
2. Switch the air conditioner ON
3. Set the air distribution control to defrost mode
4. Select the fresh (outside) air intake mode
5. Adjust the temperature control knob to maintain comfort

#### NOTICE

*To defrost the outside windshield, follow the above steps but switch OFF the AC.*

*On humid days, do not blow cold air on the windshield and side window glass, the difference between the outside and inside cabin temperature could make the fogging worse.*



### 10.12.2 Rear Windshield De-mist (if equipped)



The rear windshield glass de—mist button is located in the switch bank on the instrument panel RHS of steering, adjacent to the head lamp leveling switch. Press the button once to activate the de-mister. The LED on the button illuminates upon activation and the de-mister heats the rear windshield clearing the fog. Switch OFF the de-mister by pressing the button again as soon as the fog is cleared.

#### NOTICE

*The rear windshield de — mister switches OFF automatically after a pre-defined time.*

### 10.12.3 HVAC Points to Remember

- For quickly clearing the misted/fogged/frosted-up windshield, set the blower speed to maximum. For quick defrosting, set the temperature to extreme hot
- Once the windshield is cleared, keeping the air conditioner ON leads to dehumidified cabin heating/cooling which helps in keeping windshields and windows clear. Keep the fresh air mode selected. If required, re-adjust the blower speed and temperature control knob to maintain comfort. The temperature of air coming out of the vents should neither be too hot nor too cold
- Driving the vehicle for long with the air conditioner switched off may lead to windshield or windows getting misted/fogged up
- Driving the vehicle for long continuously in the recirculation mode may lead to windshield or windows getting misted/fogged up
- Do not blow cold air on the windshield and windows for long during humid weather. It could make windshield/windows mist/fog-up
- When on a long drive during warm humid/rainy weather, once cabin temperature becomes comfortable, shift to 'A/C ECO' mode, if using 'A/C ' mode earlier. Adjust the temperature knob such that air coming out of the vents is not too cold. Keep the fresh air intake mode selected. Shift to any distribution mode other than defrost mode. This will help in keeping windshields and windows clear



- For defogging/de-misting/defrosting the side windows at the front, select either Face or Face-Foot mode while directing air flow towards windows by adjusting the louvers of side vents. All other settings should be kept same as advised for windshield defogging/de-misting/defrosting
- For heating the vehicle interior while windshield defogging/de-misting/defrosting, select the Foot-Defrost mode. All other settings should be kept same as advised for windshield defogging/de-misting/defrosting
- For quickly defogging/de-misting/defrosting the outside of the windshield, it is advisable to operate the windshield wiper/washer for a few times intermittently
- If snow has deposited on the windshield, use an ice scraper to remove the ice deposited before using the wiper
- In freezing weather, warm the windshield with the defroster before using the windshield washer. Also use a washer fluid with anti-freezing properties. This will help prevent the washer fluid from freezing on your windshield
- A dirty/contaminated windshield would make misting/fogging worse. Always keep the inside and outside of the windshield clean
- Reduced air flow because of a clogged HVAC filter or any other obstructions in the air flow path may lead to inadequate defogging/de-misting/defrosting performance. If the air flow seems to have considerably reduced, get the filter cleaned/replaced immediately. The air flow path should be kept free of obstructions
- Reduced cooling performance from the air conditioner may lead to inadequate defogging/de-misting/defrosting. If the cooling effect seems to have dropped considerably, get the air conditioning system checked by an Authorized Mahindra Dealer





## 11 STARTING AND DRIVING THE VEHICLE

### 11.1 Safety Tips - Before Starting your Vehicle

#### 11.1.1 General

- Before starting the vehicle, inspect the inside and outside of the vehicle ; look for any damages, leaks, loose parts, foreign objects/debris. Contact an Authorized Mahindra Dealer if required.
- Before starting your journey, check the working of all safety devices/components especially brakes, steering, lamps, signals and tires. In case you suspect any system/devices not working properly contact Authorized Mahindra Dealer.
- Adjust the seat headrest, steering wheel and fasten the seat belt as described in this manual. Never perform any seat/ steering adjustments when the vehicle is in motion.
- Start the vehicle only when seated and belted in the driver's seat.



*The Engine Management System controls the engine's idle speed. When the engine starts, idle RPM runs higher than normal in order to warm the engine. The engine idle speed RPM reduces once the engine warms up.*



*Never start your vehicle in a closed garage or in an enclosed area. Exhaust fumes can be toxic. Always keep the garage door open or start the engine in an open area.*

#### 11.1.2 Mirror Adjustment

Ensure that the rear view mirror and both the ORVM's are adjusted for an unobstructed view of the road behind.

#### 11.1.3 Exterior Lamps

Have someone observe and confirm normal operation of all exterior lamps while you work on the controls from the driver seat. Also, check functioning of all lamps in the instrument panel.

#### 11.1.4 Door Latches

Check for positive closing, latching, and locking of all doors, both from inside and outside.

#### 11.1.5 Fluid Leaks

Check the area under vehicle after an overnight parking for fuel, power steering fluid, brake fluid, engine coolant, oil, or other fluid



leaks. If leaks are observed, contact an Authorized Mahindra Dealer.

## 11.2 Ignition Switch

An illuminator ring is provided on the face of the ignition switch to help in locating the ignition switch at night. The ring will illuminate the moment the driver door is opened and will remain glowing till the driver door is closed.

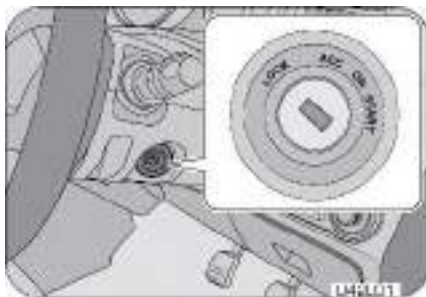

The different positions of the ignition switch are;

**LOCK** — This is the ignition and steering lock position. The vehicle circuits and engine are completely switched OFF. The steering wheel is also locked and the key can be removed from the ignition only in this position.

**ACC** — The steering is unlocked and can be rotated. In this position all electrical circuits are enabled. Use this mode when you want to listen to music, etc., with the engine temporarily switched OFF.

**ON** — All electrical circuits are enabled. Some of the warning or information lamps illuminate in this position. While some of the lamps will go out after a few seconds, some will continue to remain ON till the engine is started. When the vehicle is being driven, the ignition switch remains in the IGN position.



*Select the ignition ON position when the vehicle is being towed.*

*Do not leave the ignition ON for long when the engine is OFF. This could lead to battery drain and ignition switch damage.*

**START** — This position is to start the engine by cranking the starter motor. This is a momentary position. When the key is turned to the start position, the starter cranks the engine. Once the engine is running, release the key, and the key reverts back to the ON position and the starter motor disengages from the engine.



*Do not continue cranking after the engine has started. This will lead to damage of the starter and other engine components.*

**NOTICE**

If turning the key is difficult, jiggle the steering wheel from side to side and try again. The key can be removed only in the **LOCK** position. When the key is removed, the steering column lock is activated and the steering wheel cannot be turned.

**WARNING**

Never return the key to the **LOCK** position or try to remove the key, when the vehicle is in motion. Removing the key allows the steering wheel to lock. You will lose control of the vehicle and may cause a serious accident. Remove the key only when the vehicle is parked.

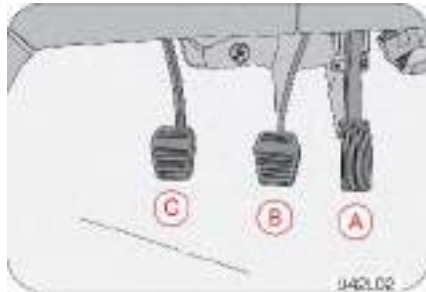
**11.3 Pedals****Manual Transmission**

A	Accelerator Pedal	B	Brake Pedal
C	Clutch Pedal		

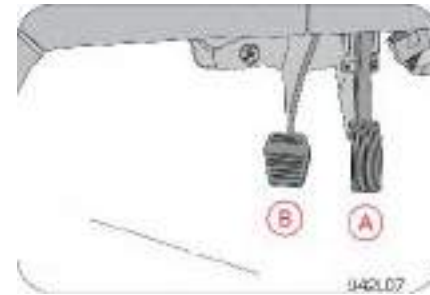
**Automated Manual Transmission (AMT)**

A	Accelerator Pedal	B	Brake Pedal
---	-------------------	---	-------------

**11.4 Starting the Engine**

Make sure all vehicle occupants are properly seated in their seats and have buckled their safety belts. For more information on seat, headrest positioning, safety belts and their proper usage, refer to the "Seat Belts" section in this manual.

**NOTICE**

*Conditions to be met before cranking the engine*





- *Make sure the gear shift lever is in neutral or clutch is fully pressed.*
- *The engine will start even if half turned and the above condition is met.*
- *Make sure the parking brake is engaged. Turn the key to IGN position but do not turn the key to start.*

#### Sequence of activities

1. Shift the gear shift lever to neutral position.
2. Apply parking brake.
3. Turn the ignition ON.
4. Wait till the glow plug lamp to switch off before the engine crank.
5. Few warning lamps briefly illuminate. See “Warning Lamps in the Instrument Cluster” section for more information.
6. Do not press the accelerator.
7. Turn the key momentarily to the START position to crank the engine
8. Once the engine starts, release the key; it will return to the IGN position



*Do not continue cranking after the engine has started. This will lead to damage of the starter and other engine components.*

9. If the engine fails to start, attempt to restart after about 10 seconds by toggling the ignition
10. If the engine fails to start even after repeated attempts as per the procedure given above, contact the nearest Authorized Mahindra Dealer



*If the vehicle battery has discharged, use booster cables, a booster battery or a battery from another vehicle to start. Jump-starting a vehicle can be dangerous if done improperly. Refer to the “Jump-starting procedure” section in this manual.*

If the engine still fails to start, contact an Authorized Mahindra Dealer for assistance.

The idle speed is controlled automatically and it will decrease as the engine warms up.

Observe the following when the engine is running;

- All warning lamps are OFF
- Low oil pressure lamp is OFF

After idling for a few seconds, release the parking brake, depress the clutch, shift the gear shift lever to 1st gear, release the service brake pedal, drive by releasing the clutch and pressing the accelerator pedal simultaneously.



### 11.4.1 Engine Idling - In Cold Weather

Avoid full throttle operation when the engine is cold and prolonged idling at low ambient temperatures. Long periods of idling may be harmful to your engine. Combustion chamber temperatures can drop so low that the fuel may not burn completely. Incomplete combustion allows carbon and varnish to form on piston rings and injector nozzles. Also, the unburned fuel can enter the crankcase, diluting the oil and causing rapid wear to the engine.

### 11.5 Stopping the Engine

Your vehicle is powered by a turbo diesel engine. Before turning the engine OFF, always allow the engine to return to normal idle speed and run for few seconds. This assures proper cooling and lubrication of the turbocharger. This is particularly necessary after any hard driving.



*To reduce the risk of personal injury, before turning OFF the engine and leaving the vehicle, always,*

- Keep your right foot on the service brake pedal
- Turn front wheels towards the road curb
- Switch OFF the ignition, turn the key to the steering lock position and remove the key
- Firmly engage the parking brake

- Move the gear shift lever to 1st gear position (reverse gear if parking on an incline)
- Slowly release the service brake pedal
- Lock your vehicle when leaving

### 11.6 Manual Transmission (If Equipped)

The first few shifts on a new vehicle may be somewhat rough. This is a normal phenomenon, and precision shifts will develop within the initial few hundred kilometers of running.

#### 11.6.1 Gear Shift Lever

The gear shift lever shifts the transmission into various gears. The gearshift pattern is shown on the gear lever knob. The clutch pedal should be depressed fully while shifting, and then released slowly.





With the gear shift lever in neutral and brakes released, the vehicle can move freely by pushing or towing. The engine can be started in this mode. It is always recommended to keep the brake pedal depressed in this position. It is advisable to shift into neutral when the vehicle is at a standstill for longer durations with the engine idling.

#### WARNING

*Coasting the vehicle with the gear lever in neutral and engine ON/OFF is not recommended. The steering and braking will be very hard without power assist while coasting with the engine OFF. In an event of panic braking, you will not have the power of engine braking to slow down the vehicle. This may lead to personal injury or accident.*

#### CAUTION

*Do not leave the vehicle with the gear shift lever in the neutral position. Always engage the manual parking brake before leaving the vehicle, to prevent any vehicle movement leading to possible injury to a by-stander or damage to the vehicle.*

*For brief stops, e. g. at traffic lights, keep the gear shift in neutral and hold the vehicle with the brake pedal. For prolonged stops, it is recommended to switch OFF the engine and apply the parking brake.*

#### WARNING

- *Do not leave children unattended in the vehicle or with access to an unlocked vehicle. Children could move the gear shift lever, which could result in an accident or serious injury*
- *On slippery/wet road surfaces, never downshift in order to obtain braking action. This could result in a wheel slip and reduced vehicle control*

**Forward** – Use the gears 1 to 5 as per vehicle load, road/traffic conditions or as per requirement.

**Reverse** – This gear is to enable the vehicle to move in the reverse direction. Move the gear shift lever into this position only after the vehicle has come to a complete stop.

#### CAUTION

*To avoid transmission damage, shift into or out of reverse gear only after the vehicle has come to a complete stop and the engine is at idle speed. It is recommended you wait approximately for three seconds in neutral gear before shifting into or out of the reverse gear.*

#### **Uphill and Downhill Driving**

To prevent the engine from laboring at a low RPM when driving uphill gradients or with your vehicle heavily loaded, downshift when necessary to maintain engine RPM within the best torque range.



Similarly while driving downhill, downshift to utilize the engine braking in an optimum manner.

### WARNING

*When stopping the vehicle on an uphill gradient, do not hold it with the clutch/ accelerator; use the brake to avoid unnecessary clutch wear/heat buildup. When parking on an incline, gear alone may not be sufficient to prevent the vehicle from moving. Always set the parking brake in addition to shifting the gear shift lever into gear. It is also recommended to turn the front wheels towards the curb.*

## 11.6.2 Recommended Gear Shifting Speeds

### CAUTION

*Shift gears at suitable engine or road speeds to safeguard the transmission components. Avoid driving in high RPM's (>3000 RPM).*

Always depress the clutch fully before moving the gear shift lever from the current position to any desired position. Perform up-shifts or down-shifts one gear at a time, do not jump gears.

### Upshifting

Shift Range	Vehicle Road Speed [kmph]	Engine RPM Range
1-2	20-25	1600-2500
2-3	30-35	
3-4	40-45	
4-5	50-55	

### Down-shifting

Shift Range	Vehicle Road Speed [kmph]	Engine RPM Range
5-4	50-45	1300-1800
4-3	40-35	
3-2	30-25	
2-1	20-15	



## 11.7 Automated Manual Transmission (AMT) (If Equipped)

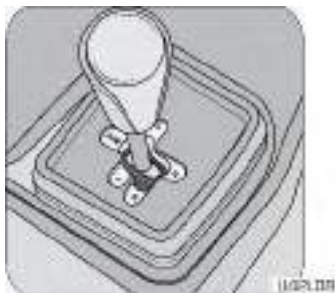

Your 'TUV300' is equipped with 5 speed Automated Manual Transmission (AMT) and a Monostable shifter. AMT has the basic features of conventional manual transmission, but clutch operation and gear shifting are controlled hydraulically.

The cluster displays the current gear position both in Auto/Manual modes. In auto mode, the gears are displayed as A1, A2, A3, A4 & A5. In Manual/Mountain mode, the gears are displayed as 1, 2, 3, 4 & 5. Neutral and reverse are displayed as "N" and "R" respectively.

N	Neutral Position
A	Automated Mode
M	Manual/Mountain Mode
R	Reverse Mode

+	Upshift (in Manual/Mountain mode)
-	Downshift (in Manual/Mountain mode)

### 11.7.1 Starting the Engine

1. Apply park brake firmly
2. Press the brake pedal
3. Ensure transmission is in N (check the cluster gear display)
4. Do not press the accelerator
5. Turn the key momentarily to the START position to crank the engine
6. Once the engine starts, release the key, it will return to the IGN position



*Do not continue cranking after the engine has started. This will lead to damage of the starter and other engine components.*

7. If the engine fails to start, attempt to restart by toggling the key.
8. If the engine fails to start even after repeated attempts as per the procedure given above, contact the nearest Authorized Mahindra Dealer

**CAUTION**

- The engine can be started only when the brake pedal is pressed and the gear shift lever is in "N" position.
- If turning the key is difficult, jiggle the steering wheel from side to side and try again. The key can be removed only in the **LOCK** position. When the key is removed, the steering column lock is activated and the steering wheel cannot be turned.
- Never return the key to the **LOCK** position or try to remove the key, when the vehicle is in motion. Removing the key allows the steering wheel to lock. You will lose the control of the vehicle and may cause serious accident. Remove the key only when the vehicle is parked.

**NOTICE**

Your vehicle is equipped with a creep function. When the gear mode is in either "A" or "M" positions, and you release your foot off the brake pedal, the vehicle starts moving without pressing the accelerator pedal. You can hold the vehicle using the park brake for momentary stops or shift to "N" mode.

**11.7.2 Driving the Vehicle****NOTICE**

Before driving, observe if any warning lamps are ON in the cluster. If yes, follow the appropriate checks given in the "Warning Lamps Overview" section of the Owner's Manual.

1. Ensure there are no warning lamps ON in the cluster
2. Idling for a few seconds
3. Press the brake pedal
4. Shift the gear shift lever to "A/M" once for auto mode and repeat it once again to Manual/Mountain mode.
5. Select '+ or -shift' shifting to Manual/Mountain mode
6. Release the parking brake
7. Release the service brake pedal



8. The vehicle starts to move with the help of the “creep” function
9. Slowly accelerate to drive away

### NOTICE

*While starting on an incline;*

- *Start the engine as per the “Starting the Engine” procedure*
- *Shift to “A” or “M”*
- *Release the service brake pedal*
- *Slowly accelerate and simultaneously release the park brake*

### 11.7.3 “N” Mode

When the “N” mode is selected, the vehicle is in “Neutral”. This mode can be used for stopping at traffic signals or for momentary stops *along with brake pedal depressed or park brake engaged*. This prevents the vehicle from moving ahead due to the creep function.

Tap the gear shift lever to the right to go to “N” position.



### NOTICE

*Though you can park your vehicle in “N” mode, it is recommended to shift to “A1” for uphill and to “R” for downhill parking.*

### WARNING

*Never shift the gearshift lever to the “N” position while driving. This will lead to loss of engine braking and in turn increase the braking distance/effort to stop the vehicle.*

### 11.7.4 “A” Mode

When the “A” mode is selected, the vehicle can be driven with automatic gear shifts as per the vehicle speed. The first gear is displayed in the cluster as “A1”. As the vehicle speed increases, the



appropriate gear is selected automatically and the same is displayed in the cluster.



Tap the gear shift lever to the left to toggle between “A/M” modes.



#### WARNING

*Do not shift the gearshift lever to the “N” position while driving. This will lead to loss of engine braking and in turn increase the braking distance/effort to stop the vehicle. If you return the gearshift lever from “N” to “A” mode, the appropriate gear will be selected according to the vehicle speed.*

#### NOTICE

*While driving downhill, it is recommended to shift to “M” mode and change to lower gear. This will enable engine braking and better vehicle control.*

### 11.7.5 “M” Mode

When the “M” mode is selected, the vehicle can be driven with manual gear shifts similar to conventional manual gears. The first gear is displayed in the cluster as “1”. As the vehicle speed increases, manually shift up by tapping the gear lever towards “+”. To downshift, tap the gear lever towards “-”. The cluster displays the current gear position.



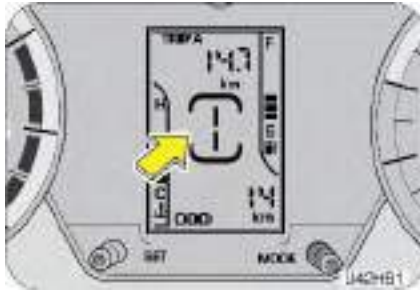

Tap the gear shift lever to the left to toggle between “A/M” modes.



#### WARNING

*Do not shift the gearshift lever to the “N” position while driving. This will lead to loss of engine braking and in turn increase the braking distance/effort to stop the vehicle. If you return the gearshift lever from “N” to “M” mode, the appropriate gear will be selected according to the vehicle speed.*

#### CAUTION

*In “M” mode, though the gear change is done manually, if the vehicle speed does not necessitate an upshift, then you will not be able to change to higher gear till the required vehicle speed is met. The same holds good for downshifts too, you can shift to a lower gear only when the vehicle speed meets the recommended speed for that particular gear.*



### 11.7.6 “R” Mode

When the “R” mode is selected, the vehicle can be driven in the reverse. The same is displayed in the cluster also.

Tap the gear shift lever towards bottom to activate reverse “R” mode.



#### CAUTION

*To avoid damage to the transmission system, ensure the vehicle comes to a complete stop before changing from “A”/“M” to “R” mode and vice versa.*

### 11.7.7 Parking your Vehicle

Your vehicle can be parked in any gear. Ensure the park brake is engaged before leaving the vehicle. It is recommended to park the vehicle with gear in “A1” for uphill and in “R” for downhill.

#### NOTICE

*Ensure the correct gear is selected [by looking at the cluster] before switching off the engine. The gear cannot be changed after switching off the engine.*

### 11.7.8 Starting off on an uphill/downhill

#### Uphill

- Apply the parking brake firmly so that the vehicle does not roll backwards
- Shift the gearshift lever to the “A/M” position while depressing the brake pedal. Make sure that the gear position indicator in the instrumental cluster displays 1st gear
- Release the brake pedal and depress the accelerator pedal gradually, and when the vehicle starts to move, release the parking brake and depress the accelerator pedal to start off

#### NOTICE

*On an uphill slope, never hold the vehicle at a stop using only the accelerator pedal or the creeping function*



*Use Manual/Mountain mode while driving in Uphill*

#### Downhill

- Depress the brake pedal and shift the gearshift lever to the “A/M” position. Make sure that the gear is in 1st by checking the gear position indicator.
- Release the brake pedal and depress the accelerator pedal slowly. Even if the accelerator pedal is not depressed, the clutch will be engaged when the vehicle speed increases.

#### NOTICE

*Use Manual/Mountain mode while driving in Downhill*

### 11.7.9 Starting in Snow or Slippery surface

- Shift to “M” mode.
- Upshift to 2nd gear.
- Slowly release the parking brake, accelerate slowly or drive in idle.

### 11.7.10 General AMT Precautions

#### WARNING

*Ensure the brake pedal is depressed or park brake engaged while vehicle is stopped with the engine running. This will prevent the vehicle from moving ahead due to the creep function.*

*Ensure park brake engaged while vehicle is stopped with the engine off.*

#### WARNING



*Any malfunction of the AMT is indicated by the “Transmission Malfunction” lamp in the instrument cluster, New key cycle to be done by switching off the engine, take of the key and then insert key again then crank engine. By following this process vehicle can be driven to nearest Mahindra Authorised Dealer.*

- Never use the accelerator pedal to hold the vehicle on an uphill slope with the gear in forward (“A” or “M”) position
- Do not rev the engine with the gear in “A” or “M” position with park/foot brake engaged. This will reduce the clutch life.
- Do not leave the vehicle unattended or with children and the engine running



- Always, put the vehicle in gear, switch off the engine and apply the park brake before leaving the vehicle

### NOTICE

- *After shifting the automated manual transmission gearshift lever to the "N" position, always check the gear position indicator in the instrument cluster shows the "N" position to make sure that the transmission is disengaged*
- *If the transmission cannot be put in neutral, turn the key from the "OFF" to the "ON" position, and move the automated manual transmission gearshift lever from "N" to "A/M", or "R", then back to "N" again. Then turn the key from the "ON" to the "OFF" position*
- *These procedures may help put the transmission in neutral. If the transmission still cannot be put in neutral, you cannot tow the vehicle without using a towing dolly*

## 11.8 Driving Your Vehicle

### 11.8.1 General Driving Precautions

#### WARNING

*Always observe the following precautions to minimize the risk of accidents leading to serious personal injury or damage to your vehicle.*

- Before you drive your vehicle, please read this manual carefully.
- Before you start driving, check proper operation of the brakes and steering system.
- If, while driving, you hear any strange noise or feel unusual vibration, or if you have any concerns whatsoever, or if any warning lamps illuminate or buzzers sound, park/stop the vehicle in a safe location as soon as possible. Identify the cause and take any necessary remedial action. Contact your Authorized Mahindra Dealer if necessary.
- Never overload or improperly load your vehicle.
- Always be attentive while driving and follow safe driving practices.
- Always maintain the recommended inflation pressure in tires.
- Always drive at a safe speed appropriate for given driving conditions. You must follow the speed limits.
- While backing up, keep a constant lookout for people, particularly children, or other obstructions or hazardous material that might be present behind the vehicle.
- Avoid loading any items on the roof that will raise the vehicles center of gravity and make your vehicle more unstable.
- Loaded vehicles, with a higher center of gravity, may handle differently than unloaded vehicles. Extra precautions, such as slower speeds and increased stopping distance, should be taken when driving a heavily loaded vehicle.



- Always slow down in gusty crosswinds. Because of its profile and higher center of gravity, your vehicle is more sensitive to side winds than an ordinary passenger car. Slowing down will allow you to have much better control.
- When driving off-road or on rugged terrain, do not drive at excessive speeds, jump, make sharp turns, strike objects, etc. This may cause loss of control or vehicle rollover causing serious injury. You are also risking expensive damage to your vehicle's suspension and chassis.
- Maintain steering wheel control at all times, especially on rough terrains. Sudden changes in terrain can result in abrupt steering wheel motion. Make sure you grip the steering wheel from the outside. Do not grip the spokes.
- If the vehicle goes from one type of surface to another [e.g. from concrete to gravel/sand/mud/snow] there will be a change in the way the vehicle responds, especially the way it responds to steering, braking and accelerating inputs.
- Be extremely careful when driving on pavements made slippery by loose sand, water, gravel, snow or ice.
- If your vehicle goes off the edge of the pavement, slow down, but avoid severe brake or steering application. Ease the vehicle back onto the pavement only after reducing your speed. Do not turn the steering wheel too sharply while returning to the road surface.
- It may be safer to stay on the apron or shoulder of the road and slow down gradually before returning to the pavement. You may

lose control if you do not slow down or if you turn the steering wheel too sharply or abruptly.

- In an unavoidable emergency situation where a sudden sharp turn must be made, turn the steering wheel only as rapidly and as far as required to avoid the emergency. Excessive steering will result in less vehicle control. Additionally, smooth variations of the accelerator and/or brake pedal pressure should be utilized if changes in vehicle speed are called for. Avoid abrupt steering, acceleration or braking which could result in an increased risk of loss of vehicle control, vehicle rollover and/or personal injury. Use all available road surfaces to return the vehicle to a safe direction of travel.

### 11.8.2 Off Road Driving Precautions

- When driving off-road or on rugged terrains, never overspeed or make sharp turns. This may cause loss of control or vehicle rollover causing serious injury.
- Maintain steering wheel control at all times. Sudden changes in terrain can result in abrupt steering wheel motion.
- Do not drive horizontally or diagonally across steep slopes, your vehicle can tip over sideways. Driving straight up or straight down is preferred.
- Drive cautiously to avoid vehicle damage from concealed objects such as rocks and stumps. You should either know the terrain or map-out your route before driving in the area.



- Always perform a maintenance inspection after each day of off-road driving that has taken you through rough terrain, sand, mud or water.

### 11.8.3 Driving Through Water

Although your vehicle is capable of driving through shallow water, there are a number of precautions that must be considered before entering the water.



*Never drive through still water that is higher than the bottom of the axle hubs. Not following this instruction will allow water to enter vehicle components causing internal damage to the components, affecting driveability, safety, emissions and reliability.*

*When driving through water, drive very slowly and at constant speed, less than 8 kmph. Drive with accelerator pedal in OFF and control speed using only the brakes. At higher speed waves can be generated by the front of the vehicle. These water waves may enter air intake, causing severe engine damage or cause a vehicle to get stalled.*

*You must slow down while driving through shallow water. Speeding may cause water to splash onto the windshield, impairing your vision. In extreme conditions you may get a water wedge formation between the road and tyre causing loss of control in the vehicle.*

- The ground under the water might not be firm which could result the water being deeper than expected when driving the vehicle through it.
- Do not stop or shut OFF the engine while immersed in water. It helps in preventing water getting inside the exhaust pipes.
- When backing down a ramp, do not allow the exhaust tail pipe to immerse in water.
- Water can wash the grease from wheel bearings, causing rusting and premature failure. It may also enter the differentials, transmission and transfer case, reducing the oil's lubricating qualities. If these are submerged in water, the lubricants should be replaced as required.
- Water entering the transmission will cause deterioration in shift quality, locking up of your transmission accompanied by vibration, and ultimately damaging the transmission.
- Sand, mud/sludge that has accumulated in brake drums and around brake discs may affect braking efficiency. This may also damage brake system components. Wet brakes cannot stop the vehicle as effectively as dry brakes. Drying can be improved by driving the vehicle slowly while applying light pressure on the brake pedal.
- When driving through water, traction or brake capability may be limited. Always perform a maintenance inspection after each day of off-road driving that has taken you through water.



### 11.8.4 Flowing Water

If the water is swift flowing and rising (as in storm run-off) avoid crossing until the water level recedes and/or the flow rate is reduced.

The flowing water can erode the streambed causing your vehicle to sink into deeper water.

Determine the exit point(s) that are downstream of your entry point to compensate for drifting.

### 11.8.5 After Driving Off-road or through Water

Off-road operation puts more stress on your vehicle than does most on-road driving. Always perform a maintenance inspection after each day of off-road driving that has taken you through rough terrain, sand, mud, or water.

- After going off-road, it is always a good idea to check for damage. Completely inspect the underbody of the vehicle for any damages.
- Check for accumulations of plants or bushes. or polyethylene / plastic These could be a fire hazard. They might also hide damage to fuel lines, brake tubes/hoses, etc.
- Inspect all the tubes/hoses and check for any fluid leakages.
- Get heat exchangers (radiator and condenser) cleaned.

- Check threaded fasteners for looseness, particularly on the chassis, drive train components, steering, suspension and brakes. Retighten them, if required, and torque to the values specified in the 'Repair Manual'.
- We also recommend that the vehicle be checked at the Authorised Dealer for any water entry into the transmission/ axle or the engine



*Abrasive material in any part of the brakes may cause excessive wear or unpredictable braking. You might not have full braking power when needed leading to accidents. If you have been operating the vehicle in off-road conditions, get the brakes checked and cleaned as necessary.*

- If any unusual vibration is experienced, check the wheels for impacted material. Impacted material can cause a wheel imbalance. Get it inspected/corrected as soon as possible.
- After driving through deep water, inspect your vehicle fluids and lubricants (engine oil, transmission/transfer case/axle oils) to ensure the fluids have not been contaminated.



## 11.9 Fuel



Use commercially available vehicular Ultra-low Sulfur Highway Diesel that meets the BIS standard (IS 1460; 2010 BS IV / BS III specification or equivalent). Information on diesel quality can normally be found in the fuel pump. Please contact any filling station personnel in case labels in the pump cannot be found.

### CAUTION

*Do not fill the fuel tank or mix the fuel with gasoline, alcohol based fuels, kerosene, etc. This will damage the engine, fuel and exhaust system components.*

### NOTICE

*If you have accidentally filled the fuel tank with an incorrect or non-approved fuel, do not start the vehicle. Contact an*

*Authorized Mahindra Dealer to have the fuel system drained completely.*

During freezing weather if the fuel is not winterized or is insufficiently winterized, waxing/gelling may take place in the fuel, leading to interruption in fuel supply to the engine. For smooth functioning and reliable operation of the engine during cold weather conditions, use winterized ULSD which is available at the filling stations during winter months. Check with your fuel retailer for further details.

### CAUTION

*Avoid inhaling fuel vapors and any skin or clothing contact. Direct skin contact with diesel or the inhalation of fuel vapor may affect your health.*

It is recommended maintaining a minimum of 10 liters of fuel in the fuel tank. Driving the vehicle till the fuel tank is empty is not recommended. Always have sufficient fuel in the tank. Check the fuel level prior to starting your journey.

### WARNING

*Never carry fuel in separate containers in the vehicle, it is dangerous and may lead to an inadvertent fuel leak or spillage.*





### 11.9.1 Fuel-Lid Opening and Closing

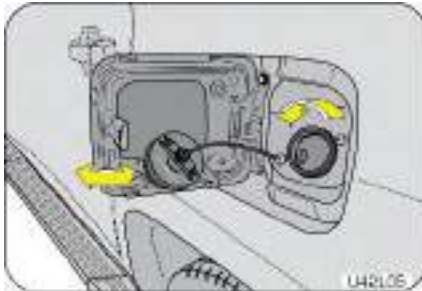
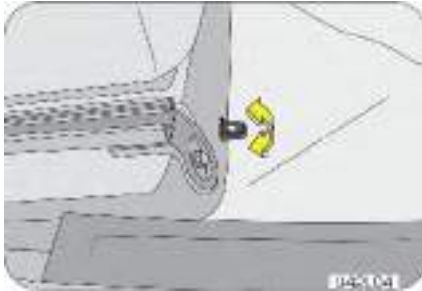

The fuel-lid can be opened by the lever located at the foot of the driver seat. Lift the lever up firmly to open.

Turn the fuel cap counter-clockwise to open. Refuel and put the cap back in its place and tighten in the clockwise direction till three distinct clicks are heard. Close the fuel lid shut.



*Ensure the fuel cap and lid are securely closed before starting the vehicle.*

### 11.10 Tips for Better Fuel Economy

Give due consideration to the points listed below for better performance of vehicle and enhancement of fuel economy.

- Smooth, moderate operation will yield savings in fuel
- Steady speeds without stopping will usually give the best fuel economy
- Ensure that the parking brake is fully released
- Idling for long periods of time will waste fuel
- Anticipate stopping; slowing down may eliminate the need to stop
- Sudden or hard accelerations reduce fuel economy
- Slow down gradually
- Drive at moderate speeds
- Revving the engine before turning it off may reduce fuel economy
- The air conditioner may reduce fuel economy



- Warming up a vehicle in neutral on cold mornings is not required and may reduce fuel economy
- While idling put the gear shift lever in the neutral position
- Resting your foot on the clutch pedal while driving will reduce fuel economy
- Combine errands and minimize stop-and-go driving
- Keep tires properly inflated. It is recommended to check your tire pressure in the morning when the tyre is cold
- Use recommended engine oil. Refer to the Maintenance Section for specifications and capacities
- Replace the fuel filter and air filter at the recommended intervals
- Shift gears at the recommended speeds and rpm bands only. Refer to the gear shifting speed table for further details
- Control the maximum speed between 90 to 100 kmph in 5<sup>th</sup> gear to achieve the best fuel efficiency
- Follow the recommended maintenance schedule and perform the owner maintenance checks recommended
- Heavily loading a vehicle or towing a trailer will reduce fuel economy
- Carrying unnecessary weight may reduce fuel economy
- Adding certain accessories to your vehicle may reduce fuel economy
- Four-wheel-drive operation (if equipped) is less fuel efficient than two-wheel-drive operation
- Driving on flat terrains offer improved fuel economy as compared to driving on hilly terrains
- Close windows during high speed driving for better fuel economy
- It is recommended to refuel in the mornings (cold weather condition)

### 11.10.1 How to Calculate Fuel Efficiency (Mileage)

1. Ensure recommended tire pressure is maintained
2. Refuel your vehicle till the fuel gun at the fuel station is auto-cut-off
3. Reset trip meter to zero
4. Drive at a moderate speed for a minimum distance of 150 km
5. Refuel at the same fuel station till the auto-cut-off mode
6. Assuming 'a' liters of fuel was filled and 'b' was the trip meter reading. Fuel Efficiency =  $b/a$  kmpl
7. We recommend that point no.2 and point no.5 should be done in cold conditions (In mornings)





## 12 WHEELS AND TYRES

### 12.1 Tyre Information

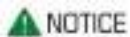

The tyres fitted in this vehicle meet the requirements of BIS and they comply with the requirements under the Central Motor Vehicles Rules [CMVR] 1989



A	Max Load Limit
B	Tyre Size

C	Radial tyres or bias-ply tyre - A radial tyre has "RADIAL/ STEEL BELTED RADIAL" on the sidewall. A tyre not marked with "RADIAL" is a bias-ply tyre.
D	"TUBELESS" or "TUBE TYPE" - A tubeless tyre does not have a tube inside the tyre and air is directly filled in the tyre. A tube type tyre has a tube inside the tyre and the tube maintains the air pressure.

### 12.2 Tyre Rating

Your vehicle is originally equipped with tyres supplied by a reputable manufacturer. If you ever have any questions regarding your tyres, please refer to literature supplied by the tyre manufacturer, or to the separate tyre warranty provided by the tyre manufacturer. You may also contact Mahindra directly, or the tyre manufacturer.

The tyre rating of your vehicle is;

- P215/75 R15 100S

Tyre rating is explained as below;

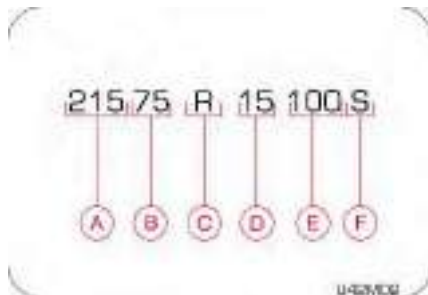

**Tyre size (example: P215/75 R15 100S)**

**(A):215 (Three-digit number):** This number gives the width in millimeters of the tyre from sidewall edge to sidewall edge. This is called 'Section Width'.

**(B):75 (Two-digit number):** This number, known as the aspect ratio, gives the tyre's ratio of height to section width.

**(C):R** This is the tyre Construction Code. The 'R' stands for Radial.

**(D):15 (Two-digit number):** This number is the wheel or rim diameter in inches.

**(E):100 (Two or three digit number):** This number is the tyre's load index. It is a measurement of how much weight each tyre can support.

**(F):S** Tyre speed rating or speed symbol. Never drive the vehicle faster than the tyre speed rating. The speed rating denotes the

speed at which a tyre is designed to be driven for extended periods of time under a standard condition of load and inflation pressure.

### 12.2.1 Speed Rating

SPEED SYMBOL	MAX SPEED CAPABILITY	SPEED SYMBOL	MAX SPEED CAPABILITY
	KM/HR		KM/HR
L	120	T	190
M	130	U	200
N	140	H	210
P	150	V	240
Q	160	W	270
R	170	Y	300
S	180	Z	240+

### 12.3 Tyre Label (Vehicle Placard)

The tyre Label (Vehicle Placard) is located on the driver door B pillar inner edge/face. This placard gives you important information about the tyre size designed for your vehicle, and the tyre inflation pressures for the front and rear tyres.



## 12.4 Tire Pressure

Proper tire inflation pressure is essential to the safe and satisfactory operation of your vehicle. Three primary areas are affected by improper tire pressure;

- Safety
- Economy
- Ride Comfort and Vehicle Stability

Proper tire inflation contributes to a comfortable and safe ride. Overinflating produces a jarring and uncomfortable ride. Both underinflation and overinflation affect the stability of the vehicle and can produce a feeling of sluggish response or over responsiveness in the steering. Unequal tire pressures can cause erratic and unpredictable steering response or may cause the vehicle to drift left or right.

Improper inflation pressures can cause uneven wear patterns to develop across the tire tread. These abnormal wear patterns will reduce tread life resulting in a need for earlier tire replacement. Under inflation also increases tire rolling resistance and results in higher fuel consumption.



### NOTICE

*The proper cold tire inflation pressure is listed in the Tire Label [Vehicle Placard], located on the front passenger side inner B-pillar.*

Tyre Size	Tyre Pressure Bar (psi)	
	Front	Rear
215/75 R15	2.2 [32]	2.2 [32]

### ⚠ WARNING

*Never overload your vehicle. Overloading can cause tyre failure, affect vehicle handling, and increase your stopping distance, resulting in an accident and/or personal injury.*

*Improperly inflated tyres can adversely affect vehicle handling or can fail unexpectedly, resulting in an accident and/or personal injury.*



### 12.4.1 Inspection and Adjustment Procedure

The tire pressure should be checked and adjusted, as well as inspected for signs of tire wear or visible damage, at least once a month. Use a good quality pressure gauge to check tire pressure. Do not make a visual judgement when determining proper inflation. Radial tires may look properly inflated even when they are underinflated. At the same time, each tire should be inspected for signs of tire wear or visible damage.

Inflation pressures specified on the placard are always cold tire inflation pressures. Cold tire inflation pressure is defined as the tire pressure after the vehicle has not been driven for at least three hours, or driven less than 1 km after a three-hour period. Check tire pressures more often if subject to a wide range of outdoor temperatures, as tire pressures vary with temperature changes. Tire pressures change by approximately 1 psi (7 kPa) per 7°C of air temperature change. Keep this in mind when checking tire pressure inside a garage, especially in the winter.

When it was new, the spare tire in your vehicle was fully inflated. However, a spare tire can lose pressure over time. In order to avoid being stranded, check the spare tire air pressure frequently.

### 12.4.2 Inflating Your Tires

Safe operation of your vehicle requires that your tires are properly inflated. Remember that a tire can lose up to half of its air pressure without appearing flat.

At least once a month or before long trips, inspect each tire and check the tire pressure with a tire gauge (including spare tire). Inflate all tires to the recommended inflation pressure.



#### WARNING

*Under-inflation is the most common cause of tire failures and may result in severe tire cracking, tread separation or "blowout", with unexpected loss of vehicle control and increased risk of injury. Under-inflation increases sidewall flexing and rolling resistance, resulting in heat buildup and internal damage to the tire. It also may result in unnecessary tire stress, irregular wear, loss of vehicle control and accidents.*

Always inflate your tires to the recommended pressure even if it is less than the maximum inflation pressure information found on the tire. The recommended tire inflation pressure is found on the Tire Label which is located on the front passenger side inner B-pillar. Failure to follow the tire pressure recommendations can cause uneven tread wear patterns and adversely affect the way your vehicle handles.

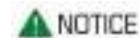

#### NOTICE

*If you overfill the tire, release air by pushing the metal stem in the center of the valve. Then recheck the pressure.*

 **WARNING**

*After inspecting or adjusting the tire pressure, always reinstall the valve stem cap (if equipped). This will prevent moisture and dirt from entering the valve stem, which could damage the stem, resulting in an unexpected loss of tire pressure, an accident and/or personal injury.*

### 12.4.3 Radial Ply Tires

 **WARNING**

*Combining radial ply tires with other types of tires on your vehicle will cause your vehicle to handle poorly, resulting in an accident and/or personal injury. Always use radial tires in sets of four. Never combine them with other types of tires.*

*Cuts and punctures in radial tires are repairable only in the tread area because of sidewall flexing. Consult your authorized dealer for radial tire repairs.*

### 12.4.4 Tread Wear Indicators (TWI)

Tread wear indicators are molded into the bottom of the tread grooves. They will appear as bands when the tread depth becomes 1/16 inch [2 mm]. When the indicators appear in two or more adjacent grooves, the tire should be replaced.

 **CAUTION**

*Avoid abrupt maneuvering and braking. This can cause tire deterioration and lead to loss of steering or braking control.*

### 12.4.5 Life of Tire

The service life of a tire is dependent upon various factors including but not limited to;

- Driving style
- Tire pressure
- Distance driven

 **WARNING**

*Tires and the spare tire should be replaced after six years, regardless of the remaining tread. Failure to follow this warning can result in sudden and unexpected tire failure, leading to an accident and/or personal injury.*

 **NOTICE**

*Keep dismantled tires in a cool, dry place with as little exposure to light as possible. Protect tires from contact with oil, grease and fuels.*





### WARNING

Do not use a tire, wheel size or speed rating other than that specified for your vehicle on the tire placard. Combinations of unapproved tires and wheels may change suspension geometric and performance characteristics, resulting in changes to steering, handling and braking of your vehicle. This can cause unpredictable handling, stress to steering and suspension components. You could lose control of the vehicle or the tire can unexpectedly fail, resulting in an accident and/or personal injury.

### NOTICE

Replacing original tires with tires of a different size may result in false speedometer and odometer readings.

## 12.4.6 Snow Chains

Snow chains cannot be used on these tires.

### WARNING

In case of harsh winter driving conditions, it is recommended using winter tires with the same specifications for better stability, safety and performance.

## 12.5 Tyre Rotation Recommendations

### Type 1 - Applicable for all 5 Steel / 5 Alloy wheels



Tyres on the front and rear axles of vehicles operate at different loads and perform different steering, handling, and braking functions. For these reasons, they wear at unequal rates and develop irregular wear patterns.

Rotation will increase tread life, help to maintain mud, snow, and wet traction levels, and contribute to a smooth, quiet ride. Follow the recommended tyre rotation frequency for your type of driving.

### Type 2 - Applicable for 4 Alloy wheels and Spare wheel with Steel rim

It is recommended rotating the tyres as per the “Maintenance Schedule”.



The suggested rotation method is the “forward-cross” shown in the diagram. The benefits of rotation are especially worthwhile with aggressive tread designs such as those on On/Off-road type tyres.

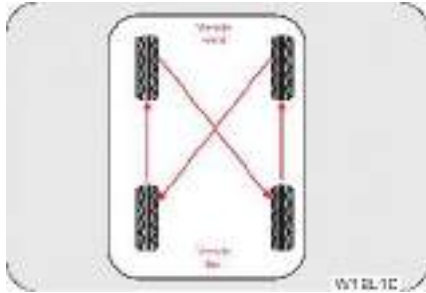

Rotation will increase tread life, help to maintain mud, snow, and wet traction levels, and contribute to a smooth, quiet ride. Follow the recommended tyre rotation frequency for your type of driving. More frequent rotation is permissible if desired. The reasons for any rapid or unusual wear should be corrected prior to rotation being performed.

### 12.5.1 Changing a Flat tyre

Refer to “If you have a Flat tyre” section in the general chapter for details.

### 12.5.2 Wheel Tightness

When you change a wheel, remove all rust and dirt at all locations where the wheel contacts the wheel hub. Use a scraper or wire brush to be sure that you remove all rust and dirt. A loose wheel could have damaged or elongated the holes in the rim, or damaged the rim/hub assembly. If any of the wheel studs or nuts are damaged, contact the nearest Authorized Mahindra Dealer.

#### WARNING

*Always tighten the nuts in a crisscross sequence. Never use oil or grease on your wheel studs or nuts.*

*Never over tighten the nuts on the wheel stud. You could damage the stud or the nut.*

*Torque tighten the wheel nuts to the specified value at the nearest Authorized Mahindra Workshop.*

#### NOTICE

*The tyres fitted in this vehicle meet the requirements of BIS and they comply with the requirements under the Central Motor Vehicles Rules (CMVR) 1989.*





## 13 EMERGENCIES

### 13.1 Hazard Warning Lamp

The hazard warning lamp switch is located above the AC controls on the instrument panel. Use the hazard warning lamp when your vehicle is stationary or to warn other road users to be cautious while passing your vehicle.

To turn the hazard warning lamp ON, press the switch in. All the turn signal lamps flash. To turn OFF, press the switch again.



#### NOTICE

*The turn lamps do not work when the hazard warning lamps are operational.*

*Hazard lamps are also switched ON during the following conditions;*

- *Crash — Hazard would be turned on for 30 mins*
- *Panic Braking — When the vehicle is running above 100 kmph and panic/sudden brakes are applied, hazard will turn on for 5 sec*
- *Vehicle break down warning bonnet open — The vehicle break down warning would be enabled only when bonnet switch changes from close to open condition at vehicle unlocked condition*

*Pressing the hazard switch twice deactivates this feature.*

### 13.2 Vehicle Does not Start - Checks

Before making these checks, make sure you have followed the correct starting procedure and that you have sufficient fuel.

#### **If the engine is not cranking or is cranking too slowly/ intermittently**

1. Check that the battery terminals are tight and clean
2. If the battery terminals are firmly fastened, turn the interior lamps ON
3. If the lamps do not illuminate, glow dim or go OFF when the starter is cranked, the battery is weak or discharged. Try jump starting. Follow 'Jump starting' instructions given later in this chapter
4. Check the fuses in the Engine Compartment Fuse Box and Central Fuse Box



#### **If the engine cranks normally, but does not start**

1. If the lamp illumination is normal, engine is cranking normally, but the engine does not start even after repeated cranking, it needs adjustment or repair. Contact an Authorized Mahindra Dealer
2. During winter, use of non-winter diesel or due to extreme cold conditions, the vehicle may not start. Contact an Authorized Mahindra Dealer for further assistance

#### **If the engine stalls while driving**

Reduce your speed gradually, keeping a straight line. Move cautiously off the road to a safe place. Turn ON your hazard warning flashers and check for any malfunction lamps in the instrument cluster. Turn the ignition OFF, wait for approximately 90 sec and try starting the engine again. If the vehicle still does not start contact an Authorized Mahindra Dealer.



#### **WARNING**

*If the engine stalls while running, the power assist for the brakes and steering will not work. Steering and braking will be much harder than usual.*

#### **If the engine speed does not increase**

If the engine speed does not increase when the accelerator pedal is depressed, there may be a problem in the Engine Management System, electrical or electronic controls. In case of certain faults, the engine may go to limp home mode, which is indicated by the

check engine lamp. Have your vehicle checked by an Authorized Mahindra Dealer as soon as possible.

### **13.3 Vehicle Overheating**

If the needle in the temperature gauge in the instrument cluster is all the way up to the H and/or the high engine coolant temperature warning lamp is ON, your engine has overheated.

If the engine is getting overheated, the Engine Management System reduces engine power substantially and may even shut the engine OFF; it is dangerous to continue driving when the engine has overheated. You need to first cool the engine down before starting to drive again.

Follow the below instructions to cool the engine down

- Progressively reduce the vehicle speed and bring the vehicle to a stop at the side of the road
- Turn ON the hazard warning flashers
- Keep the engine running at idle
- Engage the parking brake
- Switch off the air conditioner
- Wait till the engine coolant temperature drops sufficiently such that the needle in the temperature gauge is around halfway between C and H



Now switch the engine OFF and carefully open the bonnet/hood to visibly inspect the engine cooling system parts. Be cautious while doing an inspection as vehicle parts will still be too hot. Verify that the engine coolant level in the coolant recovery tank is maintained between the 'Min' and 'Max' mark. Check for possible fluid leakages. Check for damages to heat exchangers and connecting hoses. Also verify that the radiator shrouds, engine fan blades and the engine belt all are in good condition.

If any evidence of failure is observed, contact the nearest Authorized Mahindra Dealer for help. In case, no system leakage/failure is suspected, driving can be continued.

Either due to severe operating conditions or due to any system leakages or failures, the engine can get overheated. However if the engine is getting overheated repeatedly, even in normal operating conditions, get the vehicle checked by an Authorized Mahindra Dealer as soon as possible.



*Refer to the 'High Engine Coolant Temperature' section under the 'Features and Control' chapter for details.*



*If the high engine coolant temperature warning is ignored, the engine shuts OFF abruptly to safeguard engine components from overheating and consequent failure. Abrupt engine shut-off can lead to uncontrollable driving condition and accidents.*

*Stay clear of hot and rotating vehicle parts while visually inspecting the vehicle. The coolant inside the cooling system is under high pressure and temperature. Never open the pressure cap of the degassing tank when the engine is hot. Not taking precautions may lead to serious injury to your skin/eyes.*

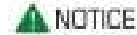

*For optimum performance of the cooling system you must maintain the required coolant level and use only recommended engine coolant.*

### 13.4 Jump Starting

If your vehicle's battery has run down, you may be able to start the engine by using a standalone booster battery or a vehicle with a good condition battery.

But before going ahead with this procedure ensure that the battery is the cause of vehicle not starting. To confirm this, few simple tests can be conducted as follows;

- **Check the headlights** - Are they dim or bright? If they are dim, it's likely your battery is dead. If your headlights are bright, you do not have a dead battery and a jump start may not help
- **Try to start your vehicle** -Does it turn over very slowly, or does it crank quickly? If it cranks quickly, you do not have a dead battery and a jump start may not help. If it cranks slowly, or not at all, you probably have a dead battery



Open the bonnet and locate the battery (near the left side fender). Identify the positive and negative terminals.

- The positive terminal will be marked with a plus sign (+) and will usually have a **RED** cable attached on it.
- The negative terminal will be marked with a minus sign (-) and will usually have a **BLACK** cable attached to it

Check the physical condition of the battery. Inspect batteries for cracks, leaks or any other damage. If you find any of these things, do not jump start the vehicle. Call Mahindra Road Side Assistance or replace the battery. If the weather is very cold, remove the refill caps and check the condition of the electrolyte. If it seems slushy or like ice, do not attempt jump-starting until it thaws.

1. Park the working vehicle near the disabled vehicle. Park the vehicle in such a way that the distance between both vehicle batteries is as small as practical. Turn off the engine, radio, lights, A/C, fans and all other electrical components. Make sure that all of these things are OFF in the disabled vehicle, too

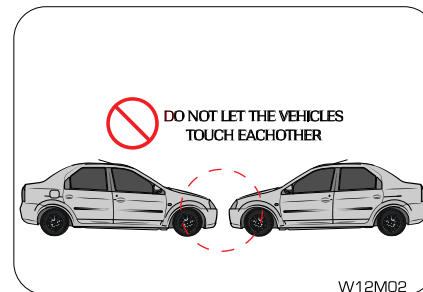

*Don't let the vehicles touch each other.*

2. Wear safety gear (goggles or face guard and gloves) if you have it.



**WARNING**

*It may be necessary to remove the disabled vehicle's battery cables from the battery terminals and clean both cables and terminals. Use a stiff wire brush to remove all corrosion. Reconnect the cables to the battery terminals and jump the vehicle.*

3. Untangle and unwind your jumper cables. Like your batteries, your jumper cables will probably have red and black cables and will have heavy duty clamps to connect to the battery terminals. You must make sure that the red and black ends of your jumper cables never touch each other once they are connected to the batteries; permitting them to do so can result in serious arcing and/or damage to one or both vehicles
4. Connect the jumper cables in the order described below;
  - Connect one red clamp to the positive (+) terminal of the dead battery/disabled vehicle
  - Connect the other red clamp to the positive (+) terminal of the good battery
  - Connect one black clamp to the negative (-) terminal of the good battery
  - Connect the other black clamp to a piece of grounded metal on the dead vehicle, preferably shiny metal (not painted or oily) that is attached to the engine. Usually a nut, bolt or other protruding shiny metal will work. You may see

a small spark when you connect to a good ground. As a last resort, you may connect to the negative (-) post of the dead battery, but this risks igniting hydrogen gas coming off the battery

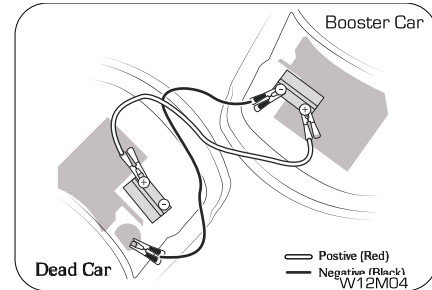
**WARNING**

*Make sure none of the cables are dangling into the engine compartment, where they could be exposed to moving parts.*

5. Start the working vehicle. Let it idle for a few minutes. Rev the engine a little above idle for 30 to 60 seconds. You do this to charge the battery in the dead vehicle. A good clean connection between the battery cables and the battery terminals is essential
6. Try to start the disabled vehicle. If it does not start, shut the engine off and disconnect the last connection temporarily while you slightly twist or wiggle each of the four clamps to





help ensure a good electrical connection. Restart the working vehicle again. Allow another 5 minutes for charging before attempting to start the disabled vehicle. If this does not work after a few tries, you may need to have the vehicle towed or the battery replaced

7. Remove the jumper cables once the vehicle starts. Do this in the reverse of the order in which they were attached, and don't let any of the cables or clamps touch each other (or dangle into the engine compartment)
  - Disconnect the black clamp from the grounded metal on the dead vehicle
  - Disconnect the black clamp from the negative (-) terminal of the good battery
  - Disconnect the red clamp from the positive (+) terminal of the good battery
  - Disconnect the red clamp from the positive (+) terminal of the dead battery

Replace any positive (+) red post protective covers if applicable (You have had to remove or open these in the beginning) These covers help prevent accidental short circuiting of the battery

8. Keep the recently-disabled vehicle's engine running. Run the vehicle above idle (slightly revved up with your foot on the accelerator). This should give the battery enough charge to start the vehicle again. If it does not, you probably have a dead battery or a dying alternator

#### WARNING

*Improper jump starting procedures can result in battery explosion and acid burn hazard.*

*Loosely connected battery cables could damage the electronic control units.*

*To disconnect battery terminals wait for at least 2 minutes to allow discharge of high voltage or it could lead to personal injury.*

*While disconnecting, always disconnect the -VE terminal first and while connecting, always connect the -VE terminal last.*

*Do not connect battery terminals with opposite polarity, it will lead to alternator failure*

#### WARNING

*Towing a vehicle to start could be dangerous. The vehicle being towed could surge forward when the engine starts, causing the tow vehicles to collide, injuring the occupants.*

*Modern vehicles with electronic management systems should not be jump started without 'protected' jump starter leads. It is necessary to refer to the owner's handbook for jump starting procedures for such vehicles.*



## 13.5 Towing

### 13.5.1 Towing Equipment



- Rear-lift equipment - The tow truck uses two pivoting arms that go under the tires (front or rear) and lift them off the ground. The other two tires remain on the ground.
- Sling-type equipment - The tow truck uses metal cables with hooks on both ends. These hooks go around parts of the frame or suspension and lift the end of the vehicle off the ground. This is not a good method of towing as it may damage the vehicle's suspension and body. Avoid a tow with sling type equipment

### 13.5.2 Towing your Vehicle During Emergency



If your vehicle needs to be towed, call a professional towing service. If a towing service is unavailable in an emergency, your vehicle may be temporarily towed by a cable or chain secured to the emergency towing hook screwed into the front towing eyelet. The tow eye is in the tools pouch under the third row seat

Towing equipment are of two types.

- Flat-bed equipment - Your vehicle is loaded on the back of a truck. This is the safest and best way of towing.



Your vehicle also comes with a rear tow hook option. The same tow eye can be screwed into the eyelet for towing.

Remove/Prise out the tow hook cover in the front LHS bumper using a screwdriver. Screw in the tow hook and tighten clockwise. Fasten a cable or chain specifically intended for use in towing vehicles to the towing hook.



*Use only the towing hook provided, for towing in an emergency. Do not tow by the bumper or any other part which may be damaged.*

*Use only the cable or chain specifically intended for use in towing vehicles.*

*A driver must be in the vehicle being towed to steer and operate the brakes. Towing in this manner must be done only on hard-surfaced roads for short distances and at low speeds.*

*Also, the wheels, axles, drive train, steering and brakes must all be in good working condition.*

*Avoid sudden starts or erratic driving maneuvers, which would place excessive stress on the towing hook and towing cable or chain, resulting in breakage of the hook or the chain.*

*If the engine is not running, the power assist for the steering and brakes will not be functional, making it harder to steer or brake than usual.*

*When lifting the rear wheels, take care to ensure adequate ground clearance for towing at the front end of the raised vehicle. The bumper and/or underbody of the vehicle may be damaged during towing.*



## 13.6 Limp Home Mode

Limp home mode is an emergency situation declared by the EMS (Engine Management System) due to failure of one/more critical sensors/actuators. In this mode, the EMS (Engine Management System) will revert back to basic minimum requirement (fuel quantity / injection timings) to aid the driver to bring the vehicle back to the nearest workshop. Needless to say the drivability & fuel consumption will be greatly affected.

If vehicle acceleration worsens or if there is a drop in vehicle performance, there might be a malfunction in the engine management system which triggers/activates the Limp Home Mode. This condition is accompanied by the check engine lamp illuminating in the instrument cluster. In this mode, the vehicle speed is limited and the accelerator pedal may not function normally. It is recommended you contact an Authorized Mahindra Dealer immediately for assistance.





## 14 MAINTENANCE

### 14.1 General Owners Information

Your vehicle has been designed for fewer maintenance requirements with longer service intervals to save both your time and money. However, each regular maintenance, as well as day-to-day care is more important to ensure a smooth, trouble free, safe and economical operation.

It is the owner's responsibility to make sure the specified maintenance, including general maintenance service is performed. Note that both the new vehicle limited warranty and emission control system limited warranties specify that proper maintenance and care must be performed. See Service Coupon Booklet for complete warranty information.

#### Where to go for service?

Mahindra technicians are well trained specialists and are kept up to date with the latest service information through technical bulletins, service tips and in dealership training programs. They learn to work on Mahindra vehicles before they work on your vehicle, rather than while they are working on it.

You can be confident that your Mahindra dealer's service department does the best job to meet the maintenance requirements on your vehicle reliably and economically.

#### Get the most from your vehicle with routine maintenance

Routine maintenance is the best way to help ensure you get the performance, dependability, long life and better resale value you expect from your vehicle. This is exactly why we've put together this Maintenance Section. It outlines the services required to properly maintain your vehicle and when they should be performed. The focus is on maintaining your vehicle while it's running great, which goes a long way toward preventing major repairs and expenses later.

Here are a few suggestions to help you get started on routine maintenance:

- Familiarize yourself with your vehicle by going through your Owner's Manual
- Take a few minutes to review this Maintenance Section
- Make it a habit to use this manual to record scheduled maintenance in the Service Coupon Booklet
- Consult with your Authorized Mahindra Dealer for all your vehicle's needs

#### 14.1.1 Suggestions for Obtaining Service for your Vehicle

##### Prepare for the Appointment

If you have warranty work to be done, be sure to have the right papers with you. All work to be performed may not be covered by



the warranty. Discuss additional charges with the service manager. Keep a maintenance log of your vehicle's service history.

#### **Prepare a List**

Make a written list of your vehicle's problems or the specific work you want done. If you've had an accident or work done that is not on your maintenance log, let the service advisor know about it.

#### **Be Reasonable with Requests**

If you list a number of items and you must have your vehicle by the end of the day, discuss the situation with the service advisor and list the items in order of priority.

### **14.1.2 Need Assistance?**

It is recommended talking to an Authorized Mahindra Dealer service manager first. Most matters can be resolved with this process. If for some reason you are still not satisfied, talk to the general manager or owner of the dealership.

If an Authorized Mahindra Dealership is unable to resolve the concern, you may contact any Mahindra Customer Care executive. They would need the following information:

Owner's name and address, owner's telephone number (home and office), Authorized Dealership name, Vehicle Identification Number (VIN), vehicle delivery date and mileage.

### **14.1.3 Warranty Information**

Read the Warranty Information given in the '**Warranty Information & Maintenance Guide**' for the terms and provisions of Mahindra warranties applicable to this vehicle. Mahindra genuine parts, fluids, lubricants and accessories are available at any Authorized Mahindra Dealer. They will help keep the vehicle operating at its best.

### **14.1.4 Protect your Warranty**

Routine maintenance is not only the best way to help keep your vehicle performing as intended, it's also the best way to protect your warranty. Failure to perform scheduled maintenance specified in the Service Coupon Booklet will invalidate warranty coverage on parts affected by the lack of maintenance. We can't stress enough how important it is to keep records of all maintenance. Damage or failures due to neglect or lack of proper maintenance are not covered under warranty.

Keeping **maintenance records** is easy with the service coupon booklet

It's important to document the maintenance of your vehicle. For your convenience to maintain records of service, the scheduled maintenance coupons are provided in the service coupon booklet. Every time you bring your vehicle in for scheduled maintenance, be sure to present this booklet and certify the work. Also record the date of service and mileage at the time of service. This will make



record keeping easy and, should your vehicle ever require warranty coverage, you will have all the documentation to show you've properly maintained it.

### **14.1.1 Maintenance Interval**

Mahindra establishes recommended maintenance intervals based upon engineering testing to determine the most appropriate mileage to perform the various maintenance services. This protects your vehicle at the lowest overall cost to you. Mahindra recommends that you do not deviate from the maintenance schedules presented in this Maintenance Schedule.

#### **14.1.1.2 Oils, Fluids and Flushing**

In many cases, fluid discoloration is a normal operating characteristic by itself, and does not necessarily indicate a concern or that the fluid needs to be changed. However, discolored fluids that also show signs of overheating and/or foreign material contamination should be inspected immediately by a qualified expert such as the factory trained technicians at your Authorized Mahindra Dealer. Your vehicle's oils and fluids should be changed at the specified intervals or in conjunction with a repair.

#### **14.1.1.3 Chemicals and Additives**

Non-Mahindra approved chemicals or additives are not required for factory recommended maintenance. In fact, Mahindra recommends against the use of such additive products unless specifically recommended by Mahindra for a particular application.

Your vehicle is very sophisticated and built with multiple complex performance systems. Every manufacturer develops these systems using different specifications and performance features. That's why it's important to rely on your Authorized Mahindra Dealer to properly diagnose and repair your vehicle.

When planning your maintenance services, consider your Authorized Mahindra Dealer for all your vehicle's needs.

#### **14.1.1.4 Get the most from your service and maintenance visits**

Getting your vehicle serviced at an Authorized Mahindra Dealer adds great value to your vehicle in number of ways. Hence, it is recommended to service your vehicle at an Authorized Mahindra Dealer only.

#### **14.1.5 Vehicle Self Maintenance - General Precautions**

- Refer to relevant sections of the manual before starting
- Set the parking brake





- Block the wheels to prevent the vehicle from moving unexpectedly
- Turn OFF the engine and remove the key
- Stay clear of hot vehicle parts
- Avoid repeated contact with fluids
- Do not let fuel, coolant and other fluids spill over electrical and hot vehicle parts
- Keep all open flames and other burning material like cigarettes away from the battery and all fuel related parts

### WARNING

*Do not start/run the engine when any engine/peripheral parts are removed.*

## 14.2 Opening/Closing the Hood

The hood release lever is located in the driver side foot well area, below the instrument panel. To open the hood, follow the steps below;

1. Pull the lever to release the hood
2. Lift the hood a little to access the safety latch holding the hood striker. This safety latch is located below the hood at the center
3. Move the safety latch to the left and lift the hood up



4. Support the hood by the stay rod



 **WARNING**

- *Do not open the hood immediately after a drive; the engine compartment will be very hot*
- *Always double check to be sure that the hood is firmly latched before driving away. If it is not latched properly, the hood could open while the vehicle is being driven, causing a total loss of visibility, resulting in an accident*
- *Do not move the vehicle with the hood in the raised position, as vision is obstructed*

Follow the below steps to close the hood;

1. Pull the hood down to a few inches above its fully closed position
2. Now, release the hood and allow it to fall by its own weight. The secondary latch is engaged now.
3. Firmly press the hood down with both your hands to engage the primary latch. This ensures that safety latch firmly locks the hood in its fully closed position



### 14.3 Identifying Components in the Engine Compartment

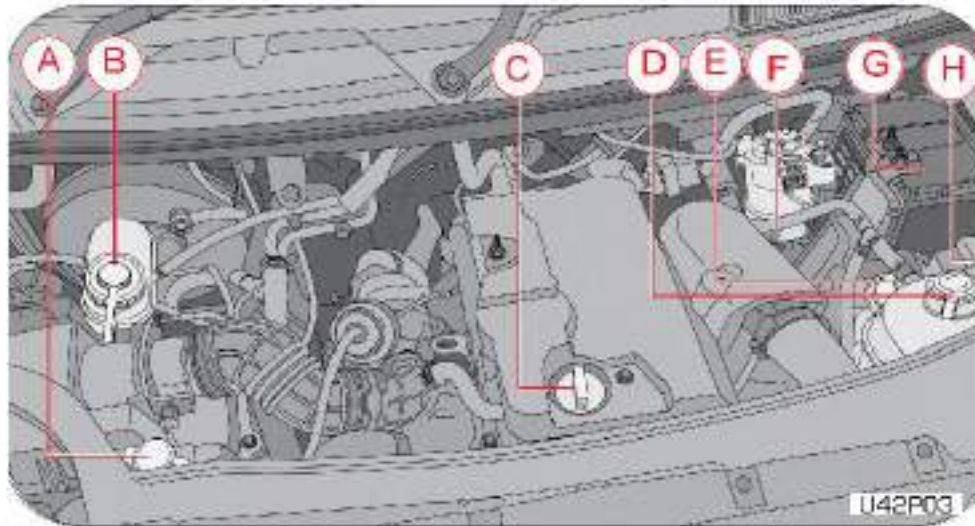

A	Windshield Washer Fluid Reservoir	E	Power Steering Fluid Reservoir
B	Brake/Clutch Fluid Reservoir	F	Dipstick (Engine Oil Level Checking)



C	Engine Oil (Engine Oil Filling)	G	Battery
D	Degassing Tank (Coolant Filling)	H	Engine Compartment Fuse Box

Maintenance is classified as below;

- General Maintenance
- Scheduled Maintenance

## 14.4 General Maintenance



*Exercise extreme caution when the hood is open and engine is ON.*

Listed below are the general maintenance items that should be performed frequently. In addition to checking the items listed below, if you notice any unusual noise, fluid leakages, smell or vibration, you should investigate the cause or take your vehicle to your Authorized Mahindra Dealer or a qualified service shop immediately.



*Make these checks only with adequate ventilation if you intend to run the engine.*

### In the Engine Compartment

- Front windshield washer fluid level

- Engine coolant level
- Battery condition
- Brake/Clutch fluid level
- Engine oil level
- Power steering fluid level
- Fluid leaks
- Hoses, joints and pipes for any abnormalities

### Inside the Vehicle

- Lights
- Warning lamps
- Windshield wiper and wash
- Steering wheel
- Seats
- Seat belts
- Accelerator pedal
- Brake pedal
- Brakes



- Parking brake
- Gear lever shift mechanism

#### **Outside the Vehicle**

- Lamps
- Fluid leaks
- Doors and engine hood latches
- Tire inflation pressure
- Tire surface/thread and wheel nuts

### **14.5 In the Engine Compartment**

#### **14.5.1 Fluid Leaks**

Check the engine compartment and the underbody of the vehicle for any leaks. If you smell fuel vapor or notice any leak, have the cause found and corrected immediately.

#### **14.5.2 Engine Oil**

Engine oil has the primary function of lubricating and cooling the inside of the engine. It plays a major role in maintaining the engine in proper working order. Therefore, it is essential to check the engine oil regularly.

#### **14.5.3 Engine Oil Consumption**

It is normal for engines to consume some engine oil during operation.

Causes of consumption in a normal engine are as follows;

- Oil is used to lubricate pistons, piston rings and cylinders. Thin films of oil, left over when pistons move in cylinders, are sucked into the combustion chamber due to high negative pressure generated when the vehicle is decelerating. This oil gets burnt in the combustion chamber
- Oil is also used to lubricate the stems of intake valves. Some of this oil is sucked into the combustion chamber together with the intake air and is burnt there
- Engine oil consumption depends upon the viscosity and quality of the oil, and upon the conditions in which the vehicle is driven. Oil consumption will be more due to high speed driving and frequent acceleration and deceleration. A new engine may consume more oil since its pistons, piston rings and cylinder walls are not conditioned

#### **14.5.4 Checking/Topping the Engine Oil**

- Make sure the vehicle is on level ground
- Turn the engine OFF and wait a few minutes for the oil to settle down into the oil sump



- Apply the parking brake
- Open the hood. Protect yourself from engine heat
- Locate and carefully remove the engine oil level dipstick



- Wipe the dipstick with a clean cloth. Insert the dipstick fully, then remove it again
- If the oil level is between 'Min' and 'Max' marks, the oil level is acceptable. **DO NOT ADD OIL**
- If the oil level is below the 'Min' mark, add enough oil through the oil filler neck to raise the level within the 'Min' and 'Max' marks. Wait for a few minutes after every top up for the oil to settle down before checking the level.

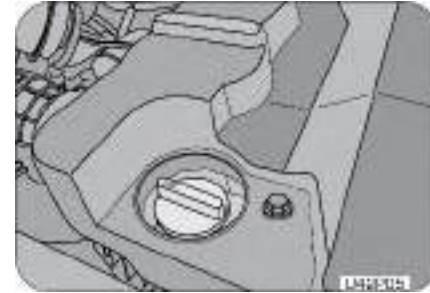

- Oil levels above the 'Max' mark may cause engine damage/poor performance.
- Put the dipstick and the oil filler cap back and ensure it is fully/properly seated.

 **CAUTION**

*To avoid possible oil loss and injury due to hot blow-by gas, **DO NOT** operate the vehicle with the engine oil level dipstick and/or the engine oil filler cap removed.*

 **NOTICE**

*Draining/Changing of engine oil should always be done by an Authorized Mahindra Dealer.*



### 14.5.5 Checking/Topping Engine Coolant Level

- Park the vehicle on a flat-horizontal surface. Keep the parking brake fully engaged. Shut-off the engine

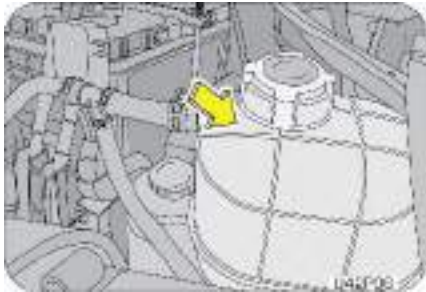

- Wait till the engine cools down and hence coolant temperature comes down to normal room temperature
- The coolant level should be between 'MIN' and 'MAX' marking provided on the coolant recovery tank
- In case the coolant level is below the 'MIN' marking, the coolant should be topped-up
- The coolant should be filled till the level rises above the 'MIN' but remain below the 'MAX' marking on the coolant recovery tank
- However if the Coolant Recovery Tank is found to be near empty, it is recommended that the system be checked at an Authorized Mahindra Dealer

#### WARNING

*Never open the pressure cap when the engine is hot. Hot coolant may splash resulting in serious personal injury or severe burns by the erupting liquid.*

#### NOTICE

*Top up only with recommended Ready-To-Use (RTU) coolants for ensuring performance, anti-freezing and corrosion protection. Do not add water directly. Mixing with other brands of coolant is not recommended and should be avoided.*

#### NOTICE

*Draining or changing of engine coolant should always be done by an Authorized Mahindra Dealer.*



### 14.5.6 Checking/Topping Brake/Clutch Fluid

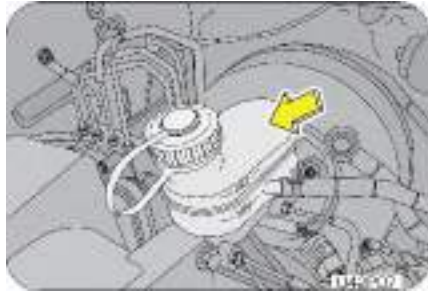

The brake system is supplied with brake fluid from the brake fluid reservoir located adjacent to the air filter.

The brake fluid level will drop slowly as the brakes wear, and will rise when the brake components are replaced. Fluid levels between the 'MIN' and 'MAX' lines are within the normal operating range; there is no need to add fluid. If the fluid levels are below the 'MIN' mark, the performance of the systems could be compromised; the brake/clutch operation could be spongy and gear change harder.

Top-up the recommended brake/clutch fluid till the 'MAX' mark or contact an Authorized Mahindra Dealer immediately.

Carefully clean the cap on the reservoir before you remove it and be sure no debris fall in the reservoir. Do not keep the reservoir open for longer than necessary to add brake fluid.

Use only brake/clutch fluid that meets Mahindra specifications. Refer to the 'Lubricant and Capacities' section.

#### NOTICE

*Draining or changing of brake/clutch fluid should always be done by an Authorized Mahindra dealer.*

### 14.5.7 Checking/Topping Power Steering Fluid

Check the power steering fluid level at the defined service intervals. Refer to Maintenance Chart for details.

The fluid level should be checked if a leak is suspected, abnormal noises are apparent, and/or the system is not functioning as anticipated. Coordinate inspection efforts through an Authorized Mahindra Dealer.

#### CAUTION

*Driving a vehicle with power steering fluid below the minimum mark will damage steering system.*

*Use only recommended power steering fluid. Do not use other types of power steering fluids which may damage the power steering system.*



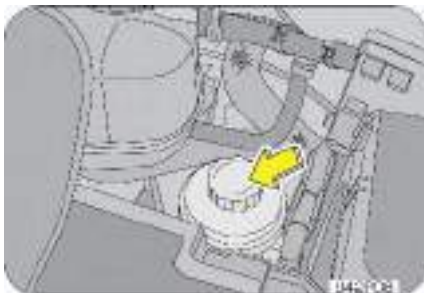

### WARNING

*The fluid level in the reservoir should be checked on a level surface with the engine OFF to prevent injury from moving parts and to ensure accurate fluid level reading.*

Follow the below steps for checking and topping up the power steering fluid;

1. Start the engine and let it run until it reaches normal operating temperature
2. While the engine idles, turn the steering wheel left and right a couple of times
3. Turn the engine OFF
4. Check the power steering fluid level in the reservoir
5. The fluid level should be maintained between the '**MIN**' and '**MAX**' marks on the dipstick, integrated with the cap

6. If the fluid is low, add fluid in small amounts, continuously checking the level until it reaches the correct operating range. Be sure to put the cap back on the reservoir
7. With a clean cloth, wipe any spilled fluid from all surfaces

### NOTICE

*Changing of power steering fluid should always be done by an Authorized Mahindra Dealer.*

## 14.5.8 Windshield Washer Fluid Top-up

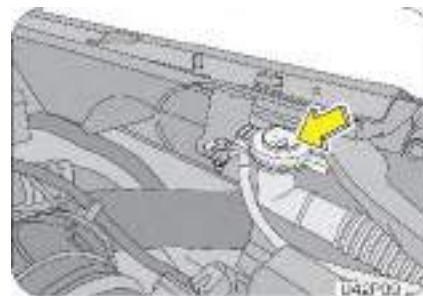

Top up the windshield washer reservoir as and when required. The fluid reservoir is located on the RHS of the engine bay behind the head lamp. The reservoir supplies washer fluid to both front and rear (if equipped).



In very cold weather conditions, fill the reservoir with washer fluid premixed with anti-freeze.



*If you operate your vehicle in temperatures below 4.5°C, use washer fluid with anti-freeze protection. Failure to use washer fluid with anti-freeze protection in cold weather could result in impaired windshield vision and increase the risk of injury or accident.*

### 14.5.9 Checking the Wiper Blades

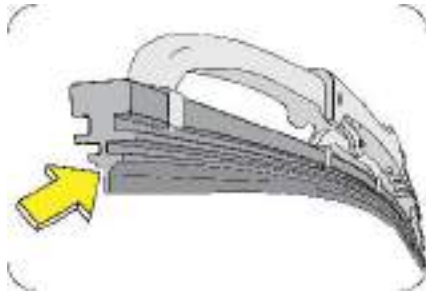

Lift the wiper arm from its position. Expose the blade lip for inspection. Clean the wiper blade lips with water applied with a soft sponge. If the wiper blade is not wiping the glass satisfactorily or is worn-out, cut, cracked or bulging get it replaced at an Authorized Mahindra Dealer.

### 14.5.10 Changing the Wiper Blade

1. Lift the arm and position the wiper blade at right angles to the wiper arm
2. Press the retaining clip in the opposite direction, disengage the wiper blade and pull it off the arm

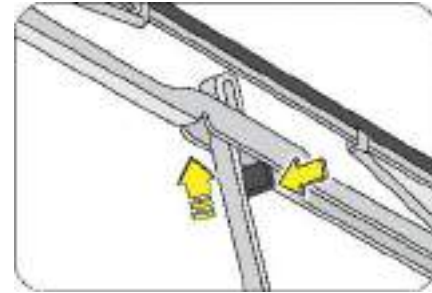

**To prevent damage to the windshield, don't let the wiper arm slap down on to it.**

3. Hold the end of the rubber and pull until the tabs are free of the metal support
4. Carefully insert the new blade rubber. Then install the blade assembly in the reverse order of removal



## 14.6 Maintenance - Inside the Vehicle

### 14.6.1 Lights

Make sure the headlights, stop lights, tail lights, turn signal lights and other lights are all working. Check headlight aim.

### 14.6.2 Warning Messages and Lamps

Check all warning lamps appearing in the instrument cluster and DDAS. Refer to the relevant sections in this manual for further details.

### 14.6.3 Seats

Check that all seat controls such as seat adjusters, seat back recliner, etc. operate smoothly and that all latches lock securely in any position. Check that the head restraints move up and down smoothly and that the locks hold securely in any latched position.

### 14.6.4 Seat Belts

Check that the seat belt system such as buckles, retractors and anchors operate properly and smoothly. Make sure the belt webbing is not cut, frayed, worn or damaged.

### 14.6.5 Accelerator Pedal

Check the pedal for smooth operation, uneven pedal effort or stickiness. Check the foot well and remove obstructions if any.

### 14.6.6 Brake Pedal

Check the pedal for smooth operation and proper clearance. Check the foot well and remove obstructions if any.

## 14.7 Maintenance - Outside the Vehicle

The following checks should be carried out from time to time, unless otherwise specified.

### 14.7.1 Lamps

Check and ensure proper functioning of all exterior lamps.

### 14.7.2 Fluid Leaks

Check the engine compartment and the underbody of the vehicle for any leaks. If you smell fuel vapor or notice any leak, have the cause found and corrected immediately.



### 14.7.3 Doors and Engine Hood

Check all doors and latches including the tailgate for proper functioning. Make sure the engine hood secondary latch secures the hood from opening when the primary latch is released.

### 14.7.4 Tyre Inflation Pressure

Check the tire pressure with a pressure gauge every week.

## 14.8 Battery

Your vehicle is equipped with a Mahindra genuine battery. For longer, trouble-free operation, keep the top of the battery clean and dry. Also, make certain the battery cables are always tightly fastened to the battery terminals.

If you see any corrosion on the battery or terminals, remove the cables from the terminals and clean with a wire brush. To prevent corrosion, apply petroleum jelly to the battery terminals. Tighten loose terminals and hold down clamp nuts only enough to keep the battery firmly in place. Tightening excessively may damage the battery terminals.

### 14.8.1 For Best Battery Service

- Keep the battery securely mounted

- Keep the battery top clean and dry
- Keep the terminals and connections clean, tight and coated with petroleum jelly or terminal grease
- Rinse any spilled electrolyte from the battery immediately with a solution of water and baking soda



*Do not disconnect battery terminals while the engine is running. This will adversely affect all electronic controllers.*



*While removing the battery, always disconnect the negative terminal first. And while installing the battery, ensure the negative terminal is connected last.*

It is recommended that the negative battery cable terminal be disconnected from the battery if you plan to store your vehicle for an extended period of time. This will minimize the discharge of your battery during storage.



*Battery fluid is a corrosive acid solution; do not allow battery acid to contact eyes, skin or clothing. Don't lean over battery when attaching clamps or allow the clamps to touch each other. If acid splashes in the eyes or on the skin, flush contaminated area immediately with large quantities of water.*



*A battery generates hydrogen gas which is flammable and explosive. Keep any flame or spark away from the vent holes.*

*Keep batteries out of reach of children. Battery posts, terminals and related accessories contain lead and lead components. Wash hands after handling batteries.*

*If the battery has been disconnected or a new battery has been installed, the clock (if equipped) and the preset radio (if equipped) stations must be reset once the battery is reconnected.*

*The replacement battery must meet the specification of the originally fitted battery.*

## 14.8.2 Checking the Electrolyte Level

Check the electrolyte level and specific gravity at intervals of three months. Check all the six cells for proper electrolyte levels. If the level is below the lower marker, add distilled water until the level reaches the upper marker.

Adding distilled water;

- Remove the vent plugs
- Add distilled water to all the cells that require the fluid and secure the plugs properly

## 14.9 Appearance Care and Protection

### 14.9.1 Washing the Exterior

- Wash your vehicle regularly with cool or lukewarm water and a neutral pH soap
- Never use strong household detergents or soap, such as dish washing or laundry liquid. These products can discolor and spot painted surfaces
- Never wash a vehicle that is 'hot to the touch' or during exposure to strong, direct sunlight
- Always use a clean sponge or car wash mitt with plenty of water for best results
- Dry the vehicle with a chamois or soft terry cloth towel in order to eliminate water spotting
- It is especially important to wash the vehicle regularly during the winter months, as dirt and road salt are difficult to remove and cause damage to the vehicle
- Immediately remove items such as gasoline, diesel fuel, bird droppings and insect deposits; they can cause damage to the vehicle's paint work and trim over time



### 14.9.2 Engine Compartment



*Do not wash the engine or engine compartment with pressurized water.*

### 14.9.3 Exterior Chrome

- Wash the vehicle first, using cool or lukewarm water and a neutral pH shampoo
- Use the custom bright metal cleaners, available at your Authorized Mahindra Dealer. Apply the product as you would wax to clean chrome parts; allow the cleaner to dry for a few minutes, and then wipe off the haze with a clean, dry rag

- Never use abrasive materials such as steel wool or plastic pads as they can leave scratches on the chrome surface
- After polishing the chrome parts, you can also apply a coating of Premium Liquid Wax, available at your Authorized Mahindra Dealer, or an equivalent quality product to help protect from environmental effects

### 14.9.4 Paint Chips

- Mahindra dealers have the exact touch-up paint to match your vehicle's color
- Take your vehicle to an Authorized Mahindra Dealer for paint touch-up or paint repairs
- Remove particles such as bird droppings, tree sap, insect deposits, tar spots, road salt and industrial fallout before repairing paint chips
- Always read the instructions before using the products

### 14.9.5 Aluminium Wheels And Wheel Covers (if equipped)

Aluminum wheels and wheel covers are coated with a clear coat of paint finish. In order to maintain their shine;

- Clean weekly with wheel and tire cleaner, which is available at your Authorized Mahindra Dealer. Heavy dirt and brake dust



accumulation may require agitation with a sponge. Rinse thoroughly with a strong stream of water

- Never apply any cleaning chemicals to hot or warm wheel rims or covers
- Do not use hydrofluoric acid-based or high caustic-based wheel cleaners, steel wool, fuels or strong household detergents

### 14.9.6 Plastic (Non-painted) Exterior Parts

Use only approved products to clean plastic parts. These products are available with your authorized dealer. You can use these cleaners;

- For routine cleaning of plastic parts
- For tar or grease spots
- For plastic head lamp lenses

### 14.9.7 Windows and Wiper Blades

The front/rear windshield, side windows and the wiper blades should be cleaned regularly. If the wipers do not wipe properly, substances on the vehicle's glass or the wiper blades may be the cause. These may include hot wax treatments used by commercial car washes, water repellent coatings, tree sap, or other organic contamination; these contaminants may cause squeaking or

chatter noise from the blades, and streaking and smearing of the windshield.

To clean these items follow these tips;

- The windshield, rear windows and side windows may be cleaned with a non-abrasive cleaner such as Clear Spray Glass Cleaner, available at your Authorized Mahindra Dealer.
- The wiper blades can be cleaned with alcohol or Premium Windshield Washer Concentrate, available at your Authorized Mahindra Dealer. This washer fluid contains a special solution in addition to alcohol which helps remove the hot wax deposited on the wiper blade and windshield. Be sure to replace wiper blades when they appear worn or do not function properly.
- Do not use abrasives, as they may cause scratches.
- Do not use fuel, kerosene, or paint thinner to clean any glass parts.

If you cannot remove those streaks after cleaning with the glass cleaner or if the wipers chatter and move in a jerky motion, clean the outer surface of the windshield and the wiper blades using a sponge or soft cloth with a neutral detergent or mild-abrasive cleaning solution. After cleaning, rinse the windshield and wiper blades with clean water. The windshield is clean if beads do not form when you rinse the windshield with water.

Do not use sharp objects, such as a razor blade, to remove decals, as it may cause damage to the glass or rear windshield heater grid lines (if equipped).



### 14.9.8 Instrument Panel/Interior Trim and Cluster Lens

#### NOTICE

*Do not use chemical solvents or strong detergents when cleaning the steering wheel or instrument panel.*

Clean the instrument panel, interior trim areas and cluster lens with a clean and damp white cotton cloth, then with a clean and dry white cotton cloth; you may also use Dash and Vinyl Cleaner on the instrument panel and interior trim areas.

- Avoid cleaners or polishes that increase the gloss of the upper portion of the instrument panel. The dull finish in this area helps protect the driver from undesirable windshield reflection
- Do not use household or glass cleaners as these may damage the finish of the instrument panel, interior trim and cluster lens

If a staining liquid like coffee/juice has been spilled on the instrument panel or on the interior trim surfaces, clean as follows;

- Wipe up spilled liquid using a clean white cotton cloth
- Apply Vinyl Cleaner to the wiped area and spread around evenly
- Apply cleaner to a clean white cotton cloth and press the cloth onto the soiled area and allow this to set in at room temperature for 30 minutes
- Remove the soaked cloth, and if it is not soiled badly, use this cloth to clean the area with a rubbing motion for 60 seconds

- Following this, wipe area dry with a clean white cotton cloth

### 14.9.9 Interior Maintenance

For fabric, carpets, cloth seats, safety belts and seats:

- Remove dust and loose dirt with a vacuum cleaner
- Remove light stains and soil with carpet and upholstery cleaner
- If grease or tar is present on the material, spot-clean the area first with a stain remover
- Do not use household cleaning products or glass cleaners, which can stain and discolor the fabric and affect the flame retardant abilities of the seat materials
- Do not use cleaning solvents, bleach or dye on the vehicle's safety belts, as these actions may weaken the belt webbing.

### 14.9.10 Leather Seats (where applicable)

Your leather seating surfaces have a clear, protective coating over the leather.

- To clean, use a soft cloth with a leather and vinyl cleaner. Dry the area with a soft cloth
- To help maintain its resiliency and color, use the leather care kit, available from an Authorized Mahindra Dealer





- Do not use household cleaning products, alcohol solutions, solvents or cleaners intended for rubber, vinyl and plastics, or oil/petroleum-based leather conditioners. These products may cause premature wearing of the clear, protective coating

#### NOTICE

*In some instances, a color or dye transfer can occur when wet clothing comes in contact with leather upholstery. If this occurs, clean the leather immediately to avoid permanent staining.*

### 14.9.11 Underbody

Flush the complete underside of your vehicle frequently. Keep body and door drain holes free from packed dirt. You can also use an anti-corrosion spray for the underbody to avoid rusting and corrosion especially for vehicles in coastal places.

### 14.10 Air Conditioning System Maintenance

Your vehicle's air-conditioning is a sealed system. Any major maintenance, such as recharging should be done by a qualified technician. However, you can do a few things by yourself to make sure the air conditioning works efficiently.

Run the air-conditioning system at least once a week, even during the cold weather months. Run it for at least ten minutes with the

engine running at normal operating temperature. This circulates the lubricating oil contained in the refrigerant.

#### CAUTION

*Whenever you get the air-conditioning system serviced, make sure the service facility uses a refrigerant recycling system. This system captures the refrigerant for re-use. Releasing the refrigerant into the atmosphere may cause damage to the environment.*

### 14.11 Vehicle Storage

If you are leaving your vehicle for more than 2 weeks you may want to take stopping to protect your battery. Disconnect the negative cable from the battery. Anytime you store your vehicle, or keep it out of service (i. e. vacation) for two weeks or more, run the air conditioning system at idle for about five minutes in the fresh air mode and high blower speed setting. This will ensure adequate system lubrication to minimize the possibility of compressor damage when the system is started again.

It is recommended storing the vehicle in a covered, clean, dry, well leveled, ventilated and closed place.



## 14.12 Winter Care

### 14.12.1 Dealing With Ice

Make sure you have window ice scrapers and de-icers for the locks. When you're stuck, having a small shovel is useful to dig out of the snow. The weight of a bag of sand in the trunk will give added traction in rear-wheel drive vehicles and can be used to sprinkle on the snow and ice to gain better traction. And don't forget personal protection such as a warm coat, hat, gloves and a blanket, in case you get stuck in a storm.

### 14.12.2 Keep Enough Fuel in the Tank

Never let the fuel level in the tank drop below the half-full mark. A sudden storm with unexpected heavy rains could leave you stranded for hours. Having adequate fuel supply will allow you to idle the engine from time to time to keep warm.

**Do not:**

- Tap the ice on the window to crack it or chip it for a good place to start scraping. You could end up cracking more than the ice and end up with a cracked or shattered windshield/ window
- Pour warm or hot water on the windshield to melt ice. This will crack your windshield

### 14.12.3 During Winter Storage

Start the engine occasionally, here are a few pointers to keep in mind;

- Run it in a well ventilated area. Carbon monoxide can build up quickly
- Run for a minimum of 20 minutes to allow the engine to come up to the normal operating temperature. This will allow the oil to circulate and will also open up the thermostat so that your radiator anti-freeze circulates as well
- Start up the air conditioner and/or heater and run both for 10 minutes or so. Again, circulating fluids is essential for good life of the system
- If your vehicle has power steering, you may want to turn the wheels a few times to keep the fluids flowing

### 14.12.4 Exterior

Wash and wax your car to provide an extra layer of protection to your paint.

### 14.12.5 Vinyl and Rubber

Use a good conditioner on all vinyl and rubber parts to prevent from drying out.



## 14.12.6 Interior

Clean the glass, shampoo the carpets, dig in between the seats to see what's there, clean the upholstery in all nooks and corners.

## 14.12.7 Engine

Check all hoses and wires to make sure everything is in good condition and replace any that need to be. The last thing to do is to make sure the internal components of the engine remain lubricated and don't corrode.

### NOTICE

*If the engine is being started after a very long period of non-use, warm up the engine at an idle speed for 2-3 minutes before driving the vehicle.*

## 14.13 Bulb Replacement

### 14.13.1 Head Lamp Bulb Replacement

### NOTICE

*The head lamp bulb can be replaced without removing the head lamp assembly from the vehicle. The head lamp assembly has been removed here for illustration purpose only.*

To replace the head lamp bulb;

- Ensure ignition is switched OFF
- Remove rear dust cover from the head lamp
- Remove the bulb assembly with connector from the head lamp by unlocking the wire clamp
- Detach the bulb assembly from the wiring connector near to the head lamp
- Insert the connector into the new bulb (of the same wattage), and follow the reverse procedure to assemble the bulb assembly in the headlight assembly
- Clamp the bulb assembly by wire clamp properly

### CAUTION

*Do not touch the new bulb with your fingers. Oil contamination will severely shorten bulb life. If the bulb comes in contact with any oily surface, clean the bulb with rubbing alcohol.*

### CAUTION

*To avoid burning yourself, do not replace the light bulbs when they are hot. Halogen bulbs have pressurized gas inside and are to be handled with special care. Mishandling it may cause the bulb to burst or shatter. Hold the bulb with its metal/plastic holder/base and do not touch the glass part with bare hands.*



*Using bulbs with units of higher output capacity/wattage is illegal and may damage your vehicle's electrical system.*

*Replacement bulbs must meet the specification of originally fitted bulbs.*

## **14.14 Scheduled Maintenance**

The scheduled maintenance jobs listed in the 'Scheduled Maintenance Chart' are those required to be carried out at regular predetermined intervals.

To make sure that your vehicle runs efficiently all the time, follow the maintenance schedule. The service interval for the scheduled maintenance is determined by the odometer reading. Take your vehicle to an Authorized Mahindra Service Station only. Trained technicians and genuine Mahindra parts at Mahindra Authorized service stations are best for your vehicle. They will perform all the scheduled maintenance jobs reliably and economically. Inadequate, incomplete and insufficient servicing may result in problems.

The owner should retain records/documents that proper maintenance has been performed as prescribed.



## 14.15 Maintenance Schedule Chart

Description	Inspect/Replace Interval	Free Services			Paid Services							
		3000	10000	20000	30000	40000	50000	60000	70000	80000	90000	100000
<b>Engine</b>												
Engine Oil <sup>1</sup>	Replace at 3000, 10000, then every 10000 kms	R	R	R	R	R	R	R	R	R	R	R
Engine Oil Filter	Replace at 3000, 10000, then every 10000 kms	R	R	R	R	R	R	R	R	R	R	R
Auto Tensioner and Drive Belts	Replace every 100000 kms							I		I		R
Coolant <sup>3</sup>	Replace at 60000, 140000, then every 80000 kms	I	I	I	I	I	I	R	I	I	I	I
<b>Air, Fuel and Exhaust</b>												
Air filter element <sup>5</sup>	Replace every 40000 kms					R				R		
Fuel Filter Element	Replace every 30000 kms				R			R			R	
Water in Fuel Filter <sup>0</sup>		C	C	C		C	C		C	C		C
<b>Transmission</b>												
Transmission Oil <sup>2</sup>	Replace at 10000, 100000, then every 100000 kms		R									R
<b>Axles, Wheels and Tires</b>												
Differential Oil <sup>2</sup>	Replace at 10000, 70000, then every 60000 kms		R						R			
Tire Rotation <sup>7</sup>	Inspect every 10000 kms		I	I	I	I	I	I	I	I	I	I
<b>Brakes</b>												
LSPV Setting (Non ABS)	Adjust at 3000, 40000, then every 40000 kms	A				A				A		
Brake & Clutch Fluid - Level & Leak <sup>e</sup>	Replace every 40000 kms or 2 yrs	I	I	I	I	R	I	I	I	R	I	I
Brake Pads/Calipers	Inspect at every 10000 kms		I	I	I	I	I	I	I	I	I	I
Brake Drum and Lining	Inspect every 20000 kms			I		I		I		I		I



Description	Inspect/Replace Interval	Free Services			Paid Services							
		3000	10000	20000	30000	40000	50000	60000	70000	80000	90000	100000
Parking Brake Operations	Adjust at 3000, 10000, then every 20000 kms	A	A		A		A		A		A	
<b>Suspension</b>												
Suspension Bushes	Inspect at 10000, then every 20000 kms		I		I		I		I		I	
Suspension Arms & Links	Inspect at 10000, then every 20000 kms		I		I		I		I		I	
<b>Steering</b>												
Power Steering Fluid - Level & Leak	Inspect every Service	I	I	I	I	I	I	I	I	I	I	I
Wheel Alignment *	At 40000 kms, earlier if abnormal wear is noticed											
<b>Electrical</b>												
Battery Electrolyte Level	Inspect every Service	I	I	I	I	I	I	I	I	I	I	I
Battery Electrolyte Specific Gravity	Inspect every Service	I	I	I	I	I	I	I	I	I	I	I
All Lamps, Horns, Wipers and Washers	Inspect every Service	I	I	I	I	I	I	I	I	I	I	I
Head Lamp Aiming	Inspect at 3000 kms	I										
<b>HVAC</b>												
Mesh Filter - Clean	Inspect every Service		C	C	C	C	C	C	C	C	C	C
<b>Final Inspection</b>												
Tyre Pressure	Inspect every Service	I	I	I	I	I	I	I	I	I	I	I
Under Chassis Bolts for Tightness	Inspect at 3000, 20000, then every 20000 kms	I		I		I		I		I		I
Exhaust Pipe Mountings and Damage/Leaks	Inspect at 3000, 20000, then every 20000 kms	I		I		I		I		I		I
Road Test - if any complaints reported	Inspect every Service	I	I	I	I	I	I	I	I	I	I	I
<b>A = Adjust as Necessary; I = Inspect &amp; correct. Replace if worn out or faulty; R = Replace; C = Clean;</b>												
*On chargeable basis; <sup>1</sup> - Change as per the km or 1 year whichever earlier; <sup>2</sup> - Change as per the km or 2 years whichever earlier												



Description	Inspect/Replace Interval	Free Services			Paid Services							
		3000	10000	20000	30000	40000	50000	60000	70000	80000	90000	100000
<sup>3</sup> - Change as per the km or 3 years whichever earlier; <sup>5</sup> - Under extreme operating conditions replace air filter every 20,000 kms												
<sup>a</sup> - Change brake & clutch fluid every 40k km or 2 yr whichever earlier; <sup>d</sup> - Check & Clean as per km or when Indicator Glows												
Note - AMT hydraulic oil top up should not be done on vehicle, it should be done after removing from vehicle												

# Alphabetical Index

## A

After Driving Off-road or through Water .....	11-18
Air Conditioning System Maintenance .....	14-20
Air Distribution Control .....	10-4
Air Intake Mode Control .....	10-6
Air-conditioner ON .....	10-6
Airbag Deployment .....	6-6
Airbag Disposal .....	6-9
Airbag Inflation/Deployment .....	6-3
Airbag Maintenance .....	6-9
Airbag Repair .....	6-9
Airbag Replacement .....	6-9
Airbag System Malfunction Lamp .....	6-2
Airbag Warning Lamp .....	8-33
Airbags .....	6-1
Aluminium Wheels And Wheel Covers .....	14-17
AMT warning Lamp .....	8-34
Anti-Lock Brake System (ABS) .....	9-6
Anti-lock Brake System (ABS) Malfunction Lamp .....	8-33
Appearance Care and Protection .....	14-16
Audio/Infotainment Manual .....	1-6
Auto Locking .....	7-6
Auto Re-locking .....	7-6
Auto Unlocking .....	7-6

## B

Battery .....	14-15
Battery Charging System Warning Lamp .....	8-31
Battery Mounted Fuse Box .....	2-11
Blower Speed Control .....	10-5
Brake Energy Regeneration Technology(If equipped) .....	8-40
Brakes .....	9-4
Bulb Replacements .....	14-22
Bulb Specification .....	2-7

## C

Can/Cup/Bottle Holders .....	8-20
Center/Side Vents .....	10-3
Central Locking System .....	7-3
Changing a Flat tyre .....	12-7
Changing the Wiper Blade .....	14-13
Check Engine Lamp .....	8-30
Checking the Electrolyte Level .....	14-16
Checking the Wiper Blades .....	14-13
Checking/Topping Brake Fluid .....	14-11
Checking/Topping Engine Coolant Level .....	14-10
Checking/Topping Power Steering Fluid .....	14-11
Checking/Topping the Engine Oil .....	14-8
Chemicals and Additives .....	14-3
Child Restraint and Airbag .....	6-6
Child Restraint System (CRS) .....	5-11
Child Safety Rear Door Lock .....	7-4

## D

Dealing With Ice .....	14-21
Defogging/De-misting and Defrosting .....	10-9
Dimensions .....	2-6
Door Ajar Warning Lamp .....	8-33
Driver and Front Passenger Air Bag .....	6-1
Driver Seat Height Adjust .....	5-3
Driving Through Water .....	11-17
Driving Your Vehicle .....	11-15

## E

ECC Lamp ( if equipped) .....	8-34
Electric ORVM Adjustment .....	8-4
Engine Compartment .....	14-17
Engine Compartment Fuse Box .....	2-8
Engine Immobilizer System .....	7-10
Engine Oil .....	14-8
Engine Oil Consumption .....	14-8

Exterior Chrome .....	14-17
Exterior Lamps .....	8-5

## F

Fastening the Seat Belt .....	5-9
Fastening the Seat Belt (2-Point Lap type) .....	5-10
Fastening the Seat Belt (3-Point type) .....	5-9
Feature Matrix .....	2-1
Flat Tire .....	2-12
Flick-Wipe (Mist) .....	8-16
Flowing Water .....	11-18
Fluid Leaks .....	14-8
Fog Lamps .....	8-9
Foldable Arm-Rests .....	5-3
Follow-Me Home (FMH) Non RKE .....	8-12
Follow-Me Home (FMH) RKE .....	8-11
Frequently Asked Questions (FAQ) .....	8-40, 8-44
Front Courtesy/Map Reading .....	8-13
Front Fog Lamp .....	8-33
Front Overview .....	3-1
Front Seat Recline .....	5-2
Front Seat Slide .....	5-2
Front Windshield-Defog .....	10-9
Fuel Level Gauge .....	8-27
Fuel-Lid Opening and Closing .....	11-20
Fuses and Relays .....	2-7

## G

Gear Selection Display .....	8-26
Gear Shift Lever .....	11-5
General Driving Precautions .....	11-15
General Maintenance .....	14-7
General Owners Information .....	14-1
General Safety Information and Instructions .....	1-2
General Warnings and Instructions .....	5-6
Get the most from your service and maintenance visits .....	14-3
Glove Box .....	8-21



# Alphabetical Index

Glow Plug Indicator..... 8-30

## H

Hazard on Panic Braking..... 8-9  
Hazard Warning Lamp..... 8-10, 13-1  
Head Lamp Bulb Replacement..... 14-22  
Head Lamp Flash..... 8-7  
Head Lamp High Beam Lamp..... 8-31  
Head Lamp High Beam/Low Beam..... 8-7  
Head Lamp Leveling System..... 8-8  
Head Lamp On..... 8-6  
Head Restraint..... 5-4  
High Engine Coolant Temperature Warning Lamp..... 8-32  
High Speed Wiping..... 8-17  
Horn..... 8-22  
How to Calculate Fuel Efficiency (Mileage)..... 11-21  
HVAC Air Filter (Cabin Air Filter)..... 10-7  
HVAC Controls..... 10-3  
HVAC Overview..... 10-2

## I

Identifying Components in the Engine Compartment..... 14-6  
If RKE is Lost..... 7-10  
Ignition Switch..... 11-2  
In the Engine Compartment..... 14-8  
Inflating Your Tires..... 12-4  
Instrument Cluster Gauges..... 8-24  
Instrument Panel Fuse Box..... 2-10  
Instrument Panel Overview..... 3-3  
Instrument Panel/Interior Trim and Cluster Lens..... 14-19  
Interior Lamps..... 8-13  
Interior Maintenance..... 14-19  
Interior Mirror..... 8-4  
Intermittent (INT) Mode..... 8-17  
Introduction..... 1-1, 6-1

## J

Jack Points..... 2-15  
Jacking..... 2-16  
Jump Starting..... 13-3

## K

Keep Enough Fuel in the Tank..... 14-21

## L

Lamps Off..... 8-6  
Lead Me to Vehicle (LMV)(RKE)..... 8-12  
Leather Seats..... 14-19  
Life of Tire..... 12-5  
Limp Home Mode..... 13-9  
Locks and Keys..... 7-1  
Low Engine Oil Pressure Warning Lamp..... 8-32  
Low Fuel Warning Lamp..... 8-32  
Low Speed Wiping..... 8-17  
Lubricants and Capacities..... 2-4

## M

Maintenance - Outside the Vehicle..... 14-14  
Maintenance Interval..... 14-3  
Maintenance Schedule Chart..... 14-24  
Maintenance-Inside the Vehicle..... 14-14  
Malfunction (OBD) Lamp..... 8-30  
Manual (Joystick) ORVM Adjustment..... 8-4  
Manual Transmission..... 11-5  
Micro Hybrid Technology (If equipped)..... 8-42  
Mike(If equipped)..... 8-34  
Mute/Un-mute Function..... 7-7

## N

Need Assistance?..... 14-2

## O

Odometer..... 8-25  
Off Road Driving Precautions..... 11-16  
Oils, Fluids and Flushing..... 14-3  
Opening the Hood..... 14-4  
Outside Rear View Mirror (ORVM)..... 8-3

## P

Paint Chips..... 14-17  
Parking Brake..... 9-5  
Parking Brake/Low Brake Fluid/EBD Warning Lamp..... 8-30  
Parking Lamps On..... 8-6  
Parking on a Hill/Incline..... 9-4  
Plastic (Non-painted) Exterior Parts..... 14-18  
Power ECO Switch..... 8-8  
Power Outlet..... 8-14  
Power Window Lock Switch..... 8-2  
Power Windows..... 8-1  
Precautions while Handling RKE..... 7-10  
Protect your Warranty..... 14-2

## R

Radial Ply Tires..... 12-5  
Radio Frequency ID (RFID) Tag..... 8-47  
Rapid Cabin Cooling..... 10-8  
Rapid Cabin Heating..... 10-8  
Rear Overview..... 3-2  
Rear Windshield-Defog..... 10-10  
Rear Wiper..... 8-17

# Alphabetical Index

Recommended Gear Shifting Speeds.....	11-7
Remote Keyless Entry (RKE) System.....	7-5
Restore the Tools, Jack and flat tyre Securely.....	2-18
Reverse Parking Assist System (RPAS)[If equipped].....	8-35
RKE Battery Replacement.....	7-9
RKE Operating Range.....	7-8
Roof Lamps.....	8-13

## S

Safety Symbols.....	1-1
Safety Tips - Before Starting your Vehicle.....	11-1
Scheduled Maintenance.....	14-23
Search (Panic) Function.....	7-7
Seat Belt Warning Lamp.....	8-33
Second Row Bench Seat.....	5-5
Security Lamp.....	8-30
Self Removing SRS Related Parts.....	6-9
Sitting in the Correct Position.....	5-1
Snow Chains.....	12-6
Spare Wheel Removal.....	2-14
Speed Rating.....	12-2
Speedometer.....	8-24
Start/Stop Lamp (Micro Hybrid).....	8-34
Starting the Engine.....	11-3
Static Bending Lamps.....	8-9
Steering.....	9-1
Steering Controls - Audio Control System.....	9-2
Stopping the Engine.....	11-5
Suggestions for Obtaining Service for your Vehicle.....	14-1
Sun Visor.....	8-22

## T

Tachometer.....	8-24
Technical Specifications.....	2-19
Temperature Control.....	10-5
Temperature Gauge.....	8-27
Theft Alarm.....	7-8

Third Row Seats.....	5-5
Tilt Steering.....	9-2
Tip-Tap ORVM Adjustment.....	8-3
Tips for Better Fuel Economy.....	11-20
Tire Pressure.....	12-3
To Lock and Arm the Vehicle with RKE.....	7-5
To Owner's of a Mahindra Vehicle.....	1-4
Towing.....	13-7
Towing Equipment.....	13-7
Towing your Vehicle during Emergency.....	13-7
Tread Wear Indicators (TWI).....	12-5
Trip Meter A, B, AC Meter & DTE.....	8-25
Turn Lamps.....	8-31
Turn Signals.....	8-5
Tyre Rating.....	12-1
Tyre Rotation Recommendations.....	12-6

## U

Underbody.....	14-20
Unfastening the Seat Belt (both 3-Point & 2-Point).....	5-11
Unlock and Disarm the Vehicle with RKE.....	7-6
Utility Holders.....	8-20

## V

Vehicle Does not Start - Checks.....	13-1
Vehicle Identification Number (VIN).....	2-21
Vehicle Overheating.....	13-2
Vehicle Self Maintenance - General Precautions.....	14-3
Voice Messaging System(VMS)[If equipped].....	8-34

## W

Warning Lamps.....	4-4
Warning Lamps in the Instrument Cluster.....	8-30

Warning Lamps Overview.....	4-3, 8-29
Warranty Information.....	14-2
Washing the Exterior.....	14-16
Water-in-Fuel Warning Lamp.....	8-32
Wheel Nut Loosening.....	2-14
Wheel Tightness.....	12-7
Windows and Wiper Blades.....	14-18
Windshield Washer Fluid Top-up.....	14-12
Windshield Wipers.....	8-16
Winter Care.....	14-21
Wipe/Wash.....	8-18
Wiper Control Stalk.....	8-16
Wiper Off.....	8-16