

MAINTENANCE

MAINTENANCE REQUIREMENTS ...	MA- 2	AUTOMATIC TRANSMISSION	
MAINTENANCE SCHEDULE	MA- 3	FLUID	MA-12
SCHEDULE FOR		MANUAL TRANSMISSION OIL	MA-13
SEVERE DRIVING	MA- 5	DRIVE SHAFT BOOT	MA-13
MAINTENANCE OPERATION	MA- 6	STEERING LINKAGE	MA-13
AIR CLEANER ELEMENT	MA- 6	STEERING GEAR BOX	MA-14
VALVE CLEARANCES	MA- 6	POWER STEERING PUMP	
ENGINE OIL & OIL FILTER	MA- 6	FLUID HOSE	MA-14
FUEL FILTER	MA- 7	SHOCK ABSORBERS	MA-14
FUEL LINE & CONNECTIONS	MA- 8	SUSPENSIONS	MA-14
ENGINE COOLANT	MA- 8	WHEEL BEARINGS	MA-14
DRIVE BELTS	MA- 9	WHEEL ALIGNMENT	MA-15
TIMING BELT	MA-10	BRAKE PEDAL	MA-15
SPARK PLUGS	MA-10	PARKING BRAKE	MA-15
BLOW-BY GAS		FRONT BRAKE DISC	
RECIRCULATION HOSE	MA-10	& DISC PAD	MA-16
CHARCOAL CANISTER	MA-10	BRAKE HOSES & TUBES	MA-16
EVAPORATIVE EMISSION		P & B VALVE	MA-16
HOSES	MA-11	BRAKE FLUID	MA-16
EXHAUST PIPE		BRAKE DRUMS & LININGS	MA-17
& MUFFLER MOUNTING	MA-11	BRAKE BOOSTER	
CLUTCH	MA-12	VACUUM HOSES	MA-17
AUTOMATIC TRANSMISSION		MASTER CYLINDER	MA-17
OIL COOLER HOSES	MA-12	WHEEL CYLINDERS	MA-17
		WHEEL HUB NUTS	MA-18

MAINTENANCE REQUIREMENTS

The scheduled maintenance service is important to ensure trouble-free, safe and economical driving. Failure to perform the scheduled maintenance may cause an accident or serious damage.

If you conduct the periodical maintenance, Daihatsu car owners may reduce the chance of accidents or car problems. Furthermore, it becomes possible for you to find at an earlier stage malfunctions which may lead to serious damages. Consequently, potential vehicle damage can be prevented or the degree of the damage can be minimized.

Therefore, all of the persons who are concerned with servicing the Daihatsu vehicles should offer the periodical maintenance service to Daihatsu car owners in order that they may be protected from accidents or unexpected problems.

To prevent malfunctions in advance, however, conducting the periodical maintenance service only is insufficient. It is essential that owners themselves perform maintenance, such as the pre-starting check described in the owner's manual, so that the vehicle exhibits no abnormal change or phenomenon. Hence, please explain to owners about the necessity of maintenance performed by them. However, malfunction may occur on those vehicles which are always checked by their owners. For instance, if a part instructed to be replaced periodically should be used beyond the replacement intervals and the life of the part has expired, there are cases where malfunction occurs suddenly despite the fact that no malfunction has taken place until yesterday. To prevent such malfunction in advance, be sure to replace parts recommended to be replaced periodically at the specified replacement intervals.

This section describes those items of the scheduled maintenance service recommended by the Daihatsu and their intervals. Be sure to observe the maintenance schedule.

LMA0002-0000

Interval	Item	Interval	Item
1000 km	Engine oil	1000 km	Engine oil
2000 km	Engine oil	2000 km	Engine oil
3000 km	Engine oil	3000 km	Engine oil
4000 km	Engine oil	4000 km	Engine oil
5000 km	Engine oil	5000 km	Engine oil
6000 km	Engine oil	6000 km	Engine oil
7000 km	Engine oil	7000 km	Engine oil
8000 km	Engine oil	8000 km	Engine oil
9000 km	Engine oil	9000 km	Engine oil
10000 km	Engine oil	10000 km	Engine oil
12000 km	Engine oil	12000 km	Engine oil
15000 km	Engine oil	15000 km	Engine oil
20000 km	Engine oil	20000 km	Engine oil
25000 km	Engine oil	25000 km	Engine oil
30000 km	Engine oil	30000 km	Engine oil
35000 km	Engine oil	35000 km	Engine oil
40000 km	Engine oil	40000 km	Engine oil
45000 km	Engine oil	45000 km	Engine oil
50000 km	Engine oil	50000 km	Engine oil
55000 km	Engine oil	55000 km	Engine oil
60000 km	Engine oil	60000 km	Engine oil
65000 km	Engine oil	65000 km	Engine oil
70000 km	Engine oil	70000 km	Engine oil
75000 km	Engine oil	75000 km	Engine oil
80000 km	Engine oil	80000 km	Engine oil
85000 km	Engine oil	85000 km	Engine oil
90000 km	Engine oil	90000 km	Engine oil
95000 km	Engine oil	95000 km	Engine oil
100000 km	Engine oil	100000 km	Engine oil

MAINTENANCE SCHEDULE

NOTE:

- Perform the periodical maintenance at the specified mileage or the time whichever comes first, unless otherwise specified.
- Continue to perform the periodical maintenance after 100,000 km (60,000 miles) at the same intervals as before 100,000 km.
- If the vehicle should be operated under severe driving conditions, operated occasionally, operated in dusty areas, repeating short trips, operated under extremely cold climate and/or on salted roads, it is necessary to perform some maintenance items more frequently than the regular maintenance schedule.
- This maintenance schedule was prepared based on requirements mentioned in the owner's manual which are to be performed by the Daihatsu owner thoroughly.

○ - Check or inspect. ● - Change or replace.

Section	Item	What to do	Inspection interval	×1000 km	1	10	20	30	40	50	60	70	80	90	100	See page
				×1000 miles	0.6	6	12	18	24	30	36	42	48	54	60	
				Years	—	0.5	1	1.5	2	2.5	3	3.5	4	4.5	5	
Engine	Air cleaner element	Cleaning Check ● Damage				○			●		○		●		○	MA-6
	Valve clearance	Check & adjustment							○				○			MA-6
	Engine oil & oil filter	Change (Use API: SG or higher grade)		Every 12,000 km												MA-6
	Fuel filter	Change		Every 100,000 km												MA-7
	Fuel line & connections (including fuel hoses)	Check ● Crack ● Tightness ● Leakage ● Damage		Every 40,000 km												MA-8
	Coolant (Long-life coolant)	Change		Every two years												MA-8
	Drive belt (Alternator, water pump, power steering)	Check ● Tension ● Crack ● Damage				○			○			○			○	
Exhaust emission control system	Timing belt	Change		Every 100,000 km												MA-10
	Spark plug	Cleaning & check ● Condition ● Gap ● Damage				○			○			○			○	MA-10
	Blow-by gas recirculation hose (Positive crankcase ventilation hose)	Check ● Connection ● Damage							○					○		MA-10
Exhaust emission control system	Charcoal canister	Check ● Function ● Damage							○					○		MA-10
	Evaporative emission hoses	Change		Every eight years												MA-11
	Exhaust pipe & muffler mounting	Check ● Tightness ● Damage				○			○			○			○	MA-11

* Replace every 10,000 km when API SF grade oil is used.

LMA00003-00000

○ - Check or inspect. ● - Change or replace

Section	Item	What to do	Inspection interval	Inspection interval												Page
				×1000 km	1	10	20	30	40	50	60	70	80	90	100	
				×1000 miles	0.6	6	12	18	24	30	36	42	48	54	60	
Years	—	0.5	1	1.5	2	2.5	3	3.5	4	4.5	5					
Power train system	Clutch	Check • Free travel • Reserve travel • Damage				○		○		○		○		○	MA-12	
	Manual transmission	Change • Oil						●					●		MA-13	
	Automatic transmission	Change • Fluid								Every 80,000 km				MA-12		
	Automatic transmission Oil cooler hose	Check • Crack, scratch, cut, twist and swelling								Every 40,000 km				MA-12		
	Drive shaft boot	Check • Damage			○		○		○		○		○		MA-13	
Suspension system	Shock absorber	Check • Function • Oil leakage (Shock absorber) • Damage			○		○		○		○		○		MA-14	
	Suspension	Check • Tightness • Damage • Rattle						○				○			MA-14	
Running system	Wheel bearing	Check • Tightness • Damage • Rattle						○					○		MA-14	
Steering system	Steering linkage, gear box	Check • Free play (Steering wheel) • Tightness • Rattle • Damage			○		○		○		○		○		MA-13	
	Wheel alignment	Check • Toe-in						○				○			MA-15	
	Fluid hose	Check • Crack, scratch, cut, twist and swelling								Every 4 years				MA-14		

UMA00004-30000

○ - Check or inspect ● - Change or replace

Section	Item	What to do	Inspection interval	×1000 km	1	10	20	30	40	50	60	70	80	90	100	See page
				×1000 miles	0.6	6	12	18	24	30	36	42	48	54	60	
				Years	—	0.5	1	1.5	2	2.5	3	3.5	4	4.5	5	
	Brake pedal & Parking brake	Check ● Free play (Brake pedal) ● Reserve travel (Brake pedal) ● Working travel (Parking brake)														MA-15
	Disc & Disc pad	Check ● Wear ● Damage														MA-16
Brake system	Brake hose, tube and P & B valve	Check ● Leakage (Fluid level, connection) ● Loose clamp ● Damage														MA-16
	Brake fluid	Change														MA-16
	Brake drum & lining	Check ● Wear ● Damage														MA-17
	Brake booster vacuum hose	Check														MA-17
	Master & wheel cylinder	Check ● Leakage														MA-17
Chassis & body	Wheel hub out, other bolts & nuts	Check ● Tightness														MA-18

LMA0005-0000

SCHEDULE FOR SEVERE DRIVING

○ - Check or inspect ● - Change or replace

Section	Item	What to do	Inspection interval	×1000 km	1	10	20	30	40	50	60	70	80	90	100	See page
				×1000 miles	0.6	6	12	18	24	30	36	42	48	54	60	
				Years	—	0.5	1	1.5	2	2.5	3	3.5	4	4.5	5	
Engine	Engine oil & oil filter	Change														MA-6
	Air cleaner element	Check & cleaning ● Damage Change														MA-6
Exhaust emission control system	Exhaust pipe and mounting	Check ● Tightness ● Damage														MA-11
Power train system	Manual transmission	Change ● Oil														MA-13
	Automatic transmission	Change ● Fluid														MA-12
Steering system	Steering linkage	Check ● Tightness ● Damage														MA-13
Brake system	Disc & disc pad	Check ● Wear ● Damage														MA-16
	Brake drum & lining	Check ● Wear ● Damage														MA-17

LMA0006-0000

MAINTENANCE OPERATION

AIR CLEANER ELEMENT

1. Perform checking every two years or 40,000 kilometer running, whichever comes first.
2. If the vehicle has been run under severe driving environments, perform cleaning every 5,000 kilometer running. Also, replace the air cleaner element every 20,000 kilometer running.
3. Take out the air cleaner element from the air cleaner case. Check the element for oil contamination or restriction.
4. When cleaning, blow compressed air first from the downstream side of the air cleaner element. Then, blow compressed air from the upstream side so that dust or other contamination may be removed.

WARNING:

- Be sure to wear safety goggles during this operation.

CAUTION:

- The pressure of the compressed air should not exceed 392 kPa.

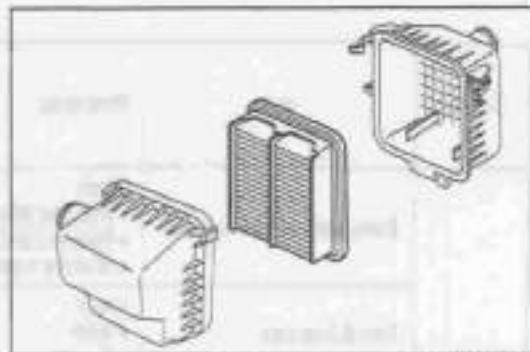

VALVE CLEARANCES

1. Perform checking every two years or 40,000 kilometer running, whichever comes first.

NOTE:

- For the adjustment procedure, refer to Section EM.

Specified Values:

Intake: 0.18 ± 0.05 mm

Exhaust: 0.25 ± 0.05 mm

(During engine cold period)

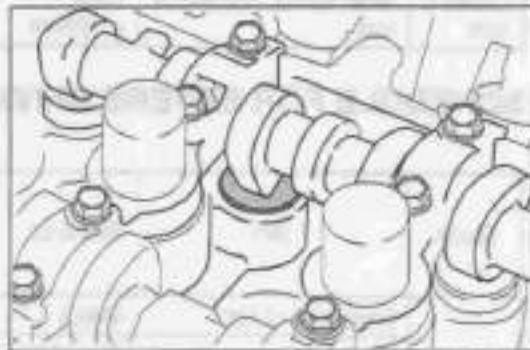

ENGINE OIL & OIL FILTER

1. Change engine oil and replace the oil filter every 12,000 kilometer running.
2. If the vehicle has been run under severe driving environments, change engine oil and replace the oil filter every 5,000 kilometer running.
3. Park the vehicle at a level place. Place a suitable container under the engine oil drain plug and oil filter.

WARNING:

- There is the possibility that you may burn yourself during this operation when the engine is hot.

4. Remove the oil filter cap so that the engine oil may be drained easily. Then, remove the drain plug and drain the engine oil.
5. Remove the oil filter.

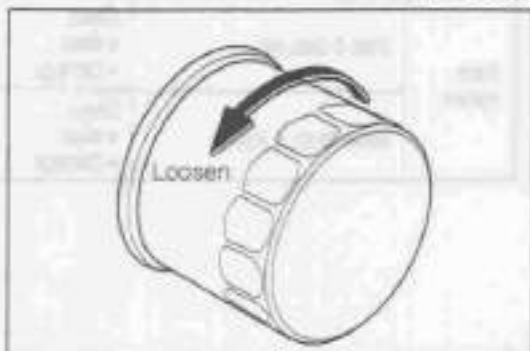

6. Wipe off thoroughly residual oil at the oil filter installation section with a cloth or the like.
7. Apply a thin film of engine oil to the O-ring section of the oil filter.
8. Install the oil filter by turning it by your hand, until the O-ring of the oil filter may fit closely to the bracket.
9. Tighten the oil filter again by turning it another one-fourth turn with the following SST.
SST: 09228-87201-000

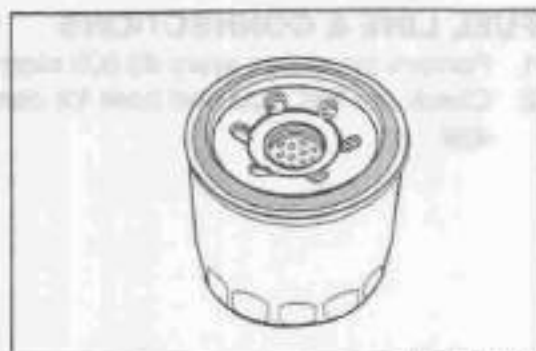

LMA00012-00036

10. Install the new gasket and drain plug to the engine oil pan.
Tightening Torque: 8.0 ± 1.6 N·m

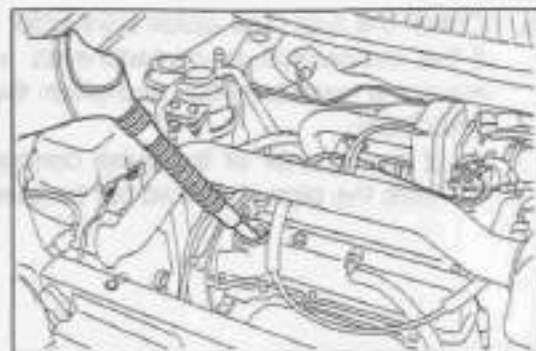

LMA00013-00007

11. Fill the engine oil.

CAUTION:

- The API grade oil of SG or higher should be used.
(The amount of oil to be filled is about 3.0 liters.)

12. Check the amount of oil that has been filled by means of the oil level gauge. Ensure that the oil level is between the L and F marks of the gauge.

NOTE:

- With a cloth or the like, wipe the forward end of the oil level gauge that will be dipped into the oil. Confirm the oil level by measuring the oil level two or three times.

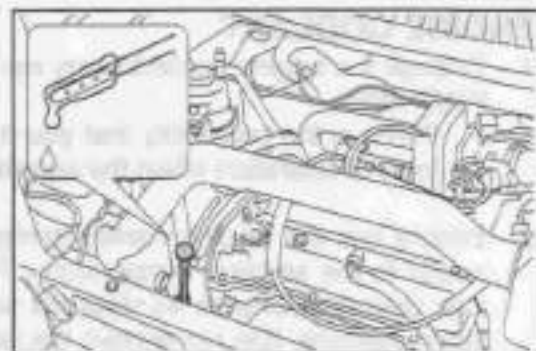

LMA00014-00008

13. Close the oil filler cap.

FUEL FILTER**NOTE:**

- Since the fuel filter is integral with the fuel pump inside the gasoline tank, the fuel pump should be replaced.

1. Replace the fuel filter every 100,000 kilometer running.
2. Lower the gasoline tank from the vehicle.
3. Remove the fuel pump.
4. Install the new fuel pump and gasket.

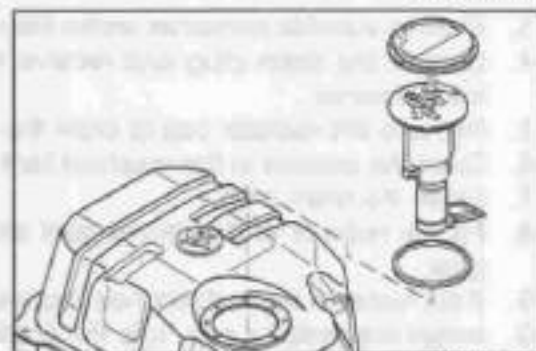
Tightening Torque: $0.6 - 0.9$ N·m

LMA00015-00009

5. Install the gasoline tank to the vehicle. Connect the pipes, etc.

NOTE:

- As for the removal and installation procedures, refer to the section BO.

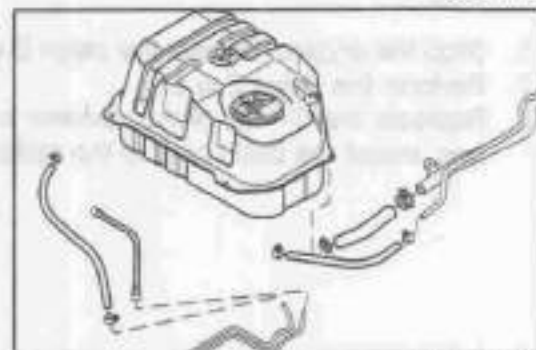

LMA00016-00010

FUEL LINE & CONNECTIONS

1. Perform the check every 40,000 kilometer running.
2. Check the fuel pipe and hose for damage, cracks or leakage.

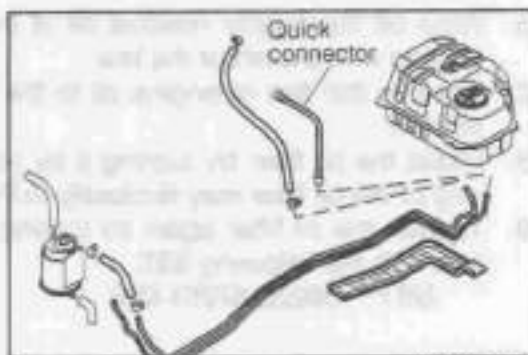

LMA0017-00011

3. Check the fuel pipe quick connector for loose connection. If the connection is contaminated with dust or mud, remove the contamination and clean the connection.

CAUTION:

- If the retainer of the quick connector is once removed from the pipe, it should not be used again.

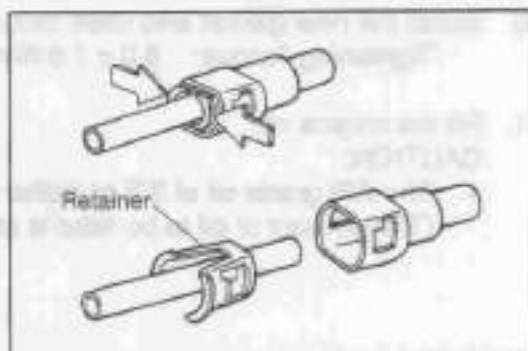

LMA0018-00012

ENGINE COOLANT

1. Change the engine coolant every two years.
WARNING:
 - There is the possibility that you may burn yourself during this operation when the engine is hot.

2. Ensure that the engine coolant temperature has dropped nearly to the ambient temperature. Then, turn the radiator cap counterclockwise 45 degrees to release the radiator inner pressure. (Do not remove the cap at this time.)

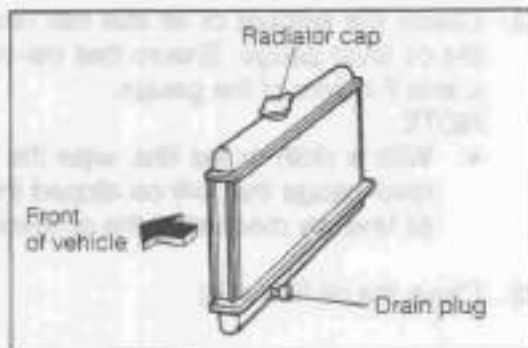

LMA0019-00013

3. Place a suitable container under the radiator drain plug.
4. Loosen the drain plug and receive the engine coolant in the container.
5. Remove the radiator cap to drain the coolant completely.
6. Drain the coolant in the reservoir tank into the container.
7. Close the drain plug.
8. Fill the radiator and reservoir tank with water. Start the engine.
9. If the water in the radiator has dropped, replenish water.
10. Install the radiator cap. Idle the engine for about five minutes.

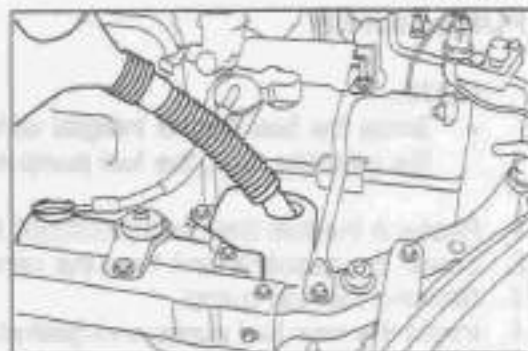

LMA0020-00014

11. Stop the engine. Repeat the steps 2 to 10 three times.
12. Perform the steps 2 to 6.
13. Replace the O-ring of the radiator drain plug with a new one. Install the drain plug to the radiator.

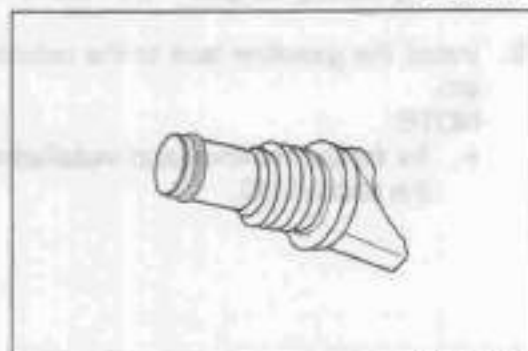

LMA0021-00015

- Fill the coolant to the radiator in the amount specified by the antifreeze manufacturer.

Coolant capacity:

Automatic transmission: 2.9 liters

Manual transmission: 3.0 liters

Reservoir tank: 0.45 liter

- Fill water to the radiator and reservoir tank.
- Close the radiator cap. Warm up the engine.
- Check the pipe connections and other sections for water leakage.
- Stop the engine. Ensure that the engine coolant temperature has dropped nearly to the ambient temperature. Then, turn the radiator cap counterclockwise 45 degrees to release the radiator inner pressure completely. Open the radiator cap and check to see if the coolant level has dropped. Replenish the coolant, as required.
- Drain the water in the reservoir tank. Replenish the coolant which has been prepared by mixing water and antifreeze in accordance with the instructions of the antifreeze manufacturer to the reservoir tank.
- Securely close the radiator cap and reservoir tank lid.

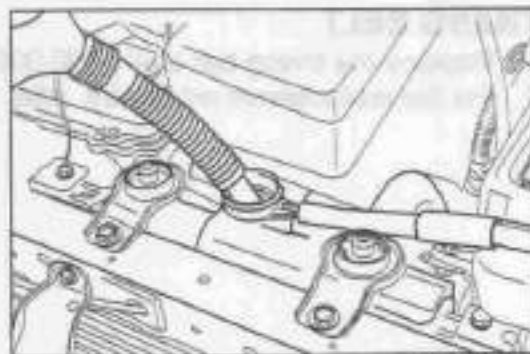

LMA00022-00016

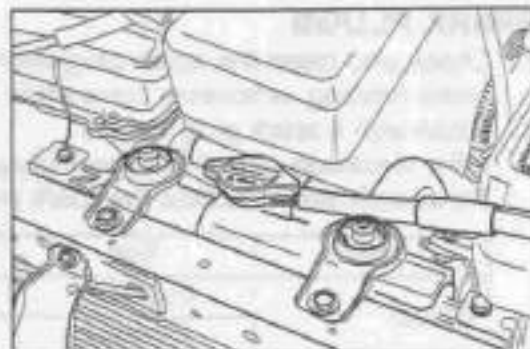

LMA00023-00017

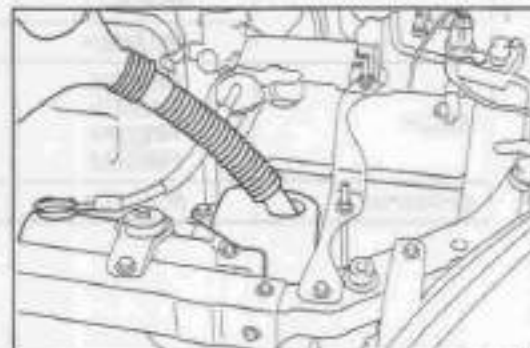

LMA00024-00018

DRIVE BELTS

- Check the drive belt every year or 20,000 kilometer running, whichever comes first.
- Check the rubber for deterioration, cracks or exposure of the core. Also check the drive belt for damage.
- If the drive belt exhibits defects, replace it.
- Check the drive belt for tension.

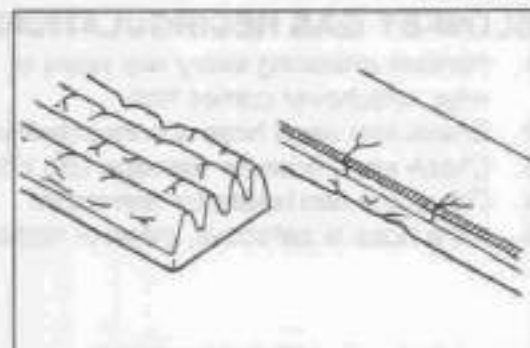

LMA00025-00019

NOTE:

- After installing a new drive belt, run the engine for at least about five minutes. Then, check the belt deflection.

Specified Value:

Between alternator and crankshaft pulley:

6 - 7 mm

Between power steering pump and water pump:

7.5 - 11.5 mm

(When a force of 98 N is applied at midpoint of pulleys:)

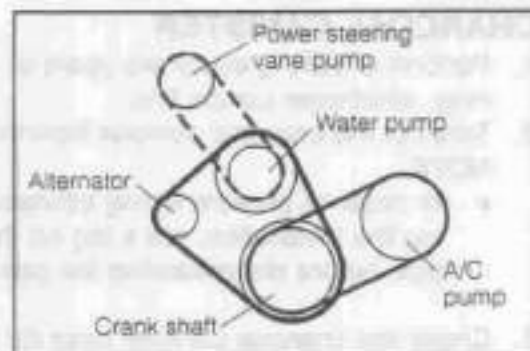

LMA00026-00020

MA-10

TIMING BELT

1. Replace the timing belt every 100,000 kilometer running.
2. For the replacement procedure, refer to Section EM.

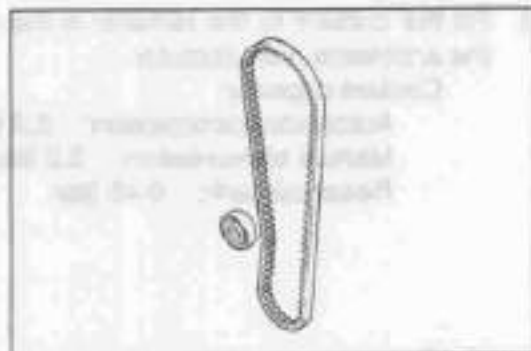

LMA00027-00021

SPARK PLUGS

1. Check and clean the spark plug every year or 20,000 kilometer running, whichever comes first.
2. Clean with a spark plug cleaner.
3. If the electrode gap of the spark plug does not conform to the specification, replace the spark plug.



LMA00028-00022

Make	Type	Gap setting
DENSO	K16FR-U11	1.0 - 1.1 mm
	K20TNR-S	0.9 - 1.0 mm
NGK	BKR5E-11	1.0 - 1.1 mm
	BKUR6EK	0.9 - 1.0 mm
BOCH	FR6DPX FR6DCX FR8DPX FR8DCX	1.0 - 1.1 mm
CHAMPION	RC10YC4	1.0 - 1.1 mm

BLOW-BY GAS RECIRCULATION HOSE

1. Perform checking every two years or 40,000 kilometer running, whichever comes first.
2. Check that each hose is connected securely.
3. Check each hose for damage and cracks.
4. Check the two hoses for restriction.
5. If the hose is defective, clean or replace it.

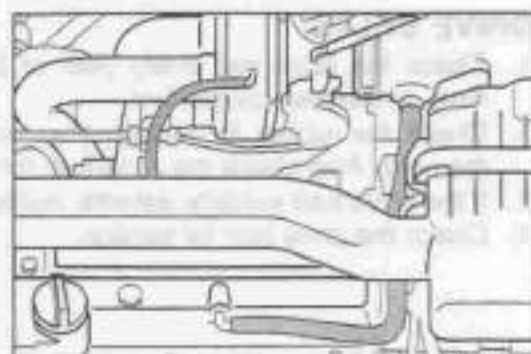

LMA00029-00023

CHARCOAL CANISTER

1. Perform checking every two years or 40,000 kilometer running, whichever comes first.
2. Take out the charcoal canister from the vehicle.

NOTE:

- In order to prevent wrong connection of the pipes during the installation, put a tag on the connection of each pipe before disconnecting the pipes.

3. Check the charcoal canister case for cracks or other damages.

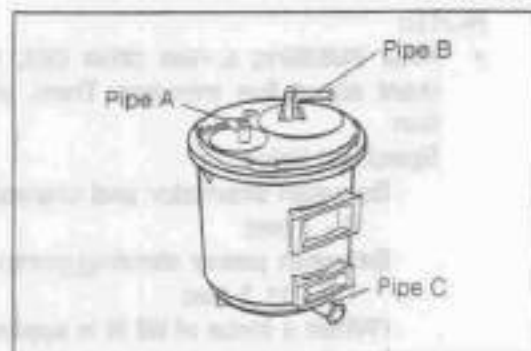

LMA00030-00024

- Close the pipe B of the charcoal canister (at the fuel tank side) with a suitable plug. Install a MityVac to the pipe C (at the atmosphere side).
- Apply a negative pressure of about 30 kPa with a MityVac. Ensure that no air flows from the pipe A (at the throttle body side).
- If the charcoal canister is defective, replace it.

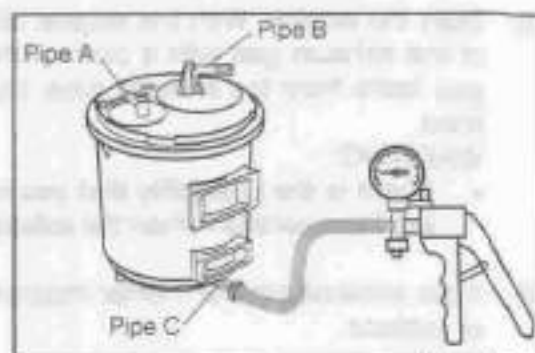

LMA00031-00025

- Close the pipe A (at the throttle body side) of the charcoal canister with a suitable plug. Install a MityVac to the pipe C (at the atmosphere side).
- Apply negative pressure with a MityVac. Ensure that air flows from the pipe B (at the fuel tank side). If the charcoal canister is defective, replace it.

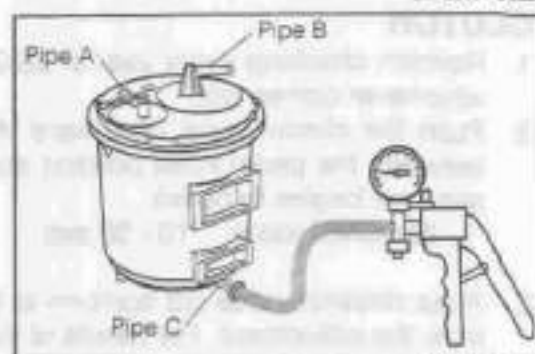

LMA00033-00035

- Install a MityVac to the pipe A (at the throttle body side) of the charcoal canister.
- Apply negative pressure with a MityVac. Ensure that air flows from the pipe B (at the fuel tank side) and pipe C (at the atmosphere side). If the charcoal canister is defective, replace it.

CAUTION:

- After the check has been conducted, if there is no defect, install the charcoal canister to the vehicle. Be sure to make connections at the piping with new hose bands and clips.

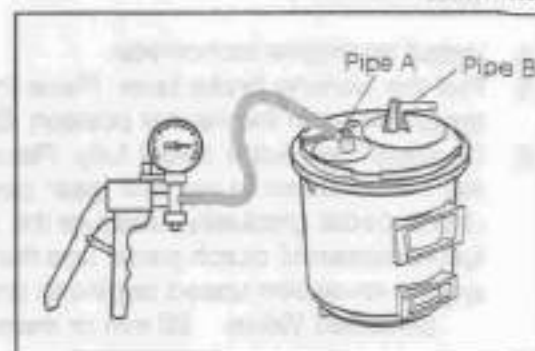

LMA00030-00027

EVAPORATIVE EMISSION HOSES

- Replace the hoses every eight years.

CAUTION:

- Be sure to make connections at the piping with new hose bands and clips.

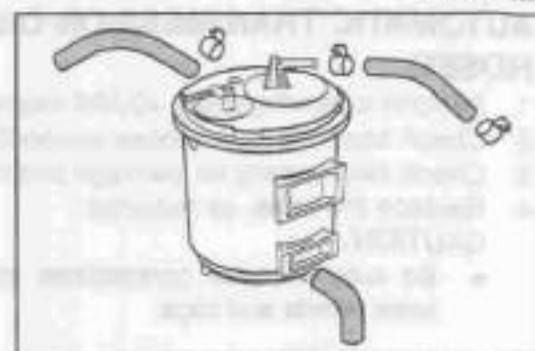

LMA00034-00025

EXHAUST PIPE & MUFFLER MOUNTING

- Perform checking every year or 20,000 kilometer running, whichever comes first.
- If the vehicle has been run under severe driving environments, perform check every six months or 5,000 kilometer running, whichever comes first.
- Check the exhaust pipe and muffler for damage.
- Check the mounting of the exhaust pipe and muffler for defects.

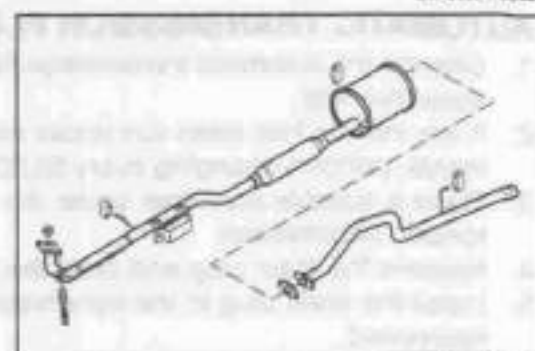

LMA00035-00025

5. Start the engine. With the engine idling, restrict the outlet of the exhaust gas with a cloth or the like. Ensure that no gas leaks from the exhaust pipe, muffler or their connections.

WARNING:

- There is the possibility that you may burn yourself during this operation when the exhaust pipe is hot.

6. If the exhaust pipe or muffler mounting is defective, repair or replace.

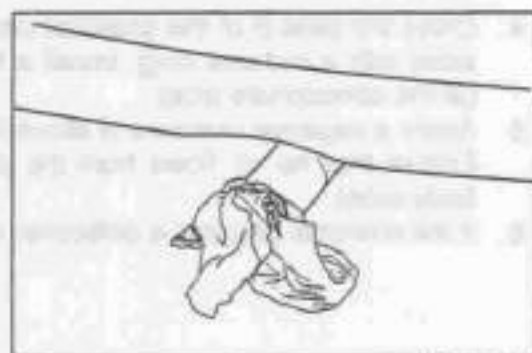

LMA00036-00030

CLUTCH

1. Perform checking every year or 20,000 kilometer running, whichever comes first.
2. Push the clutch pedal downward. Measure the distance between the pedal initial position and a point where a resistance begins to be felt.

Specified Value: 10 - 30 mm

3. If the distance does not conform to the specification, perform the adjustment. For details of the adjustment, refer to Section MT.

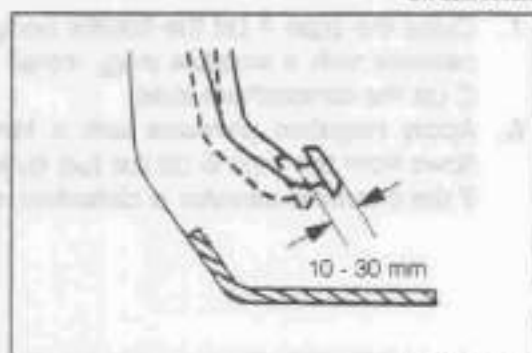

LMA00037-00031

4. Install an engine tachometer.
5. Pull the parking brake lever. Place the shift position of the transmission in the neutral position. Start the engine.
6. Depress the clutch pedal fully. Place the shift position of the transmission in the first gear position. Disengage the clutch pedal gradually. Measure the distance between the fully-depressed clutch pedal and the pedal just before the engine revolution speed begins to drop.

Specified Value: 20 mm or more

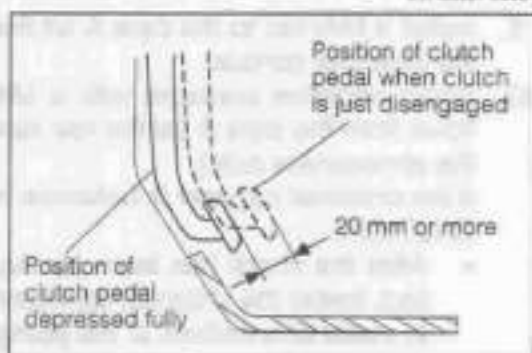

LMA00039-00032

AUTOMATIC TRANSMISSION OIL COOLER HOSES

1. Perform checking every 40,000 kilometer running.
2. Check each piping for loose connection.
3. Check each piping for damage and cracks.
4. Replace the hose, as required.

CAUTION:

- Be sure to make connections at the piping with new hose bands and clips.

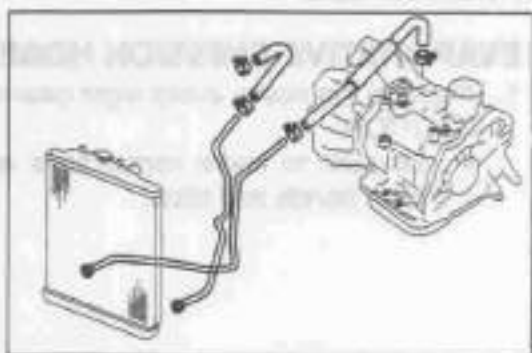

LMA00039-00033

AUTOMATIC TRANSMISSION FLUID

1. Change the automatic transmission fluid every 80,000 kilometer running.
2. If the vehicle has been run under severe driving environments, perform changing every 50,000 kilometer running.
3. Place a suitable container under the drain plug of the automatic transmission.
4. Remove the drain plug and drain the fluid.
5. Install the drain plug to the transmission with a new gasket interposed.

Tightening Torque: 19.6 - 29.4 N·m

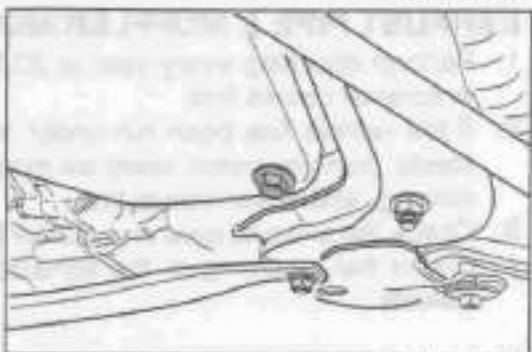

LMA00040-00034

6. Fill the specified fluid from the filler tube.
Grade: ATF DEXRON® II or III
Filling Amount: 1.9 liters

NOTE:

- For details of the operation, refer to Section AT.

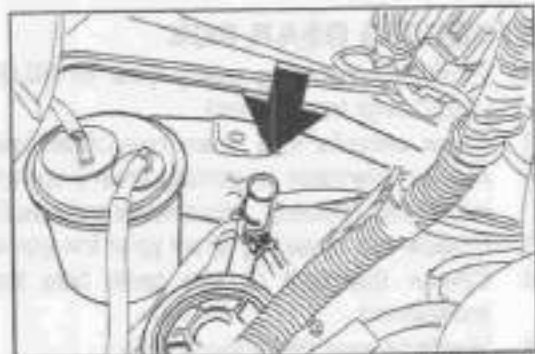

LMA00041-00035

MANUAL TRANSMISSION OIL

1. Change the manual transmission oil every two years or 40,000 kilometer running, whichever comes first.
2. If the vehicle has been run under severe driving environments, change the manual transmission oil every 25,000 kilometer running.
3. Place a suitable container under the drain plug of the transmission.
4. Remove the drain plug and drain the oil.
5. Install the drain plug to the transmission with a new gasket interposed.

Tightening Torque: 29.4 - 49.0 N·m

6. Fill the specified oil from the filler plug hole.
Grade: API GL-3 or GL-4
Viscosity: SAE75W-85
Filling Amount: 2.1 - 2.25 liters
7. Install the filler plug to the transmission with a new gasket interposed.
Tightening Torque: 29.4 - 49.0 N·m

NOTE:

- For details of the operation, refer to Section MT.

DRIVE SHAFT BOOT

1. Perform checking every year or 20,000 kilometer running, whichever comes first.
2. Check the boot for damage and cracks.
3. If the boot exhibits defects, replace it. Seal new grease.

NOTE:

- For the operation procedure, refer to Section FS.

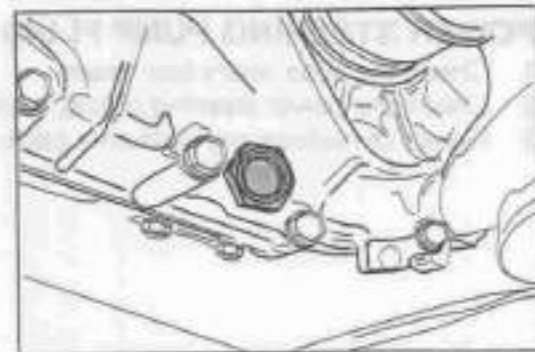

LMA00045-00026

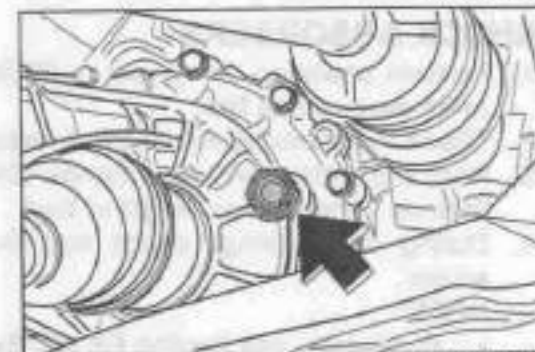

LMA00043-00037

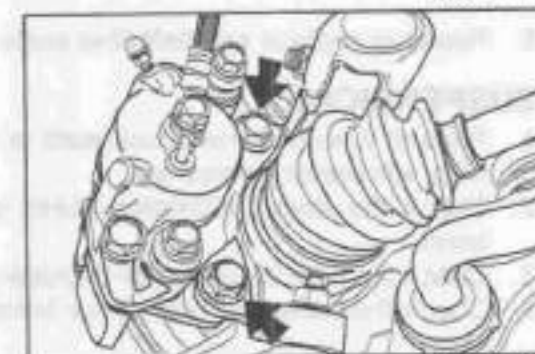

LMA00044-00038

STEERING LINKAGE

1. Perform checking every year or 20,000 kilometer running, whichever comes first.
2. If the vehicle has been run under severe driving environments, perform checking every six months or every 5,000 kilometer running, whichever comes first.
3. Check the dust cover of the tie rod end ball joint for cracks and damage.
4. Check the steering rack boot for cracks and damage.
5. Repair or replace any defective parts.

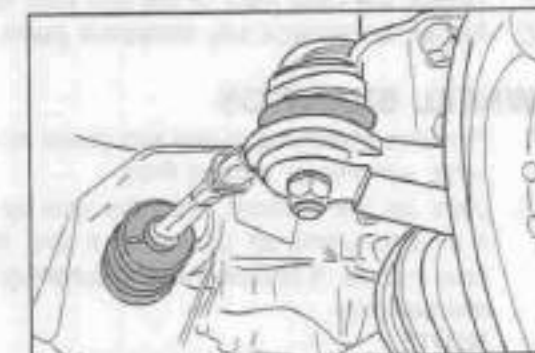

LMA00046-00039

STEERING GEAR BOX

1. Perform checking every year or 20,000 kilometer running, whichever comes first.
2. If the vehicle has been run under severe driving environments, perform checking every six months or every 5,000 kilometer running, whichever comes first.
3. Check the steering shaft joint for looseness.
4. Check the bolt of the gear box installation bracket for looseness.
5. Replace any defective parts.

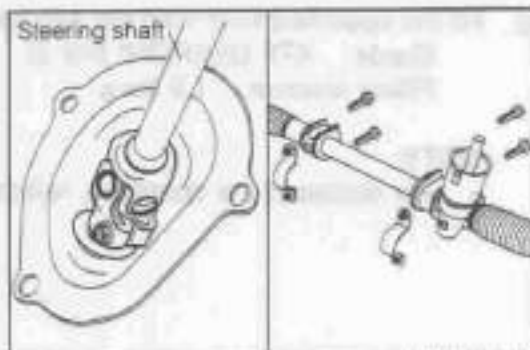

POWER STEERING PUMP FLUID HOSE

1. Check the hose every four years.
2. Check the power steering piping system for fluid leakage.
3. Repair or replace any defective parts.

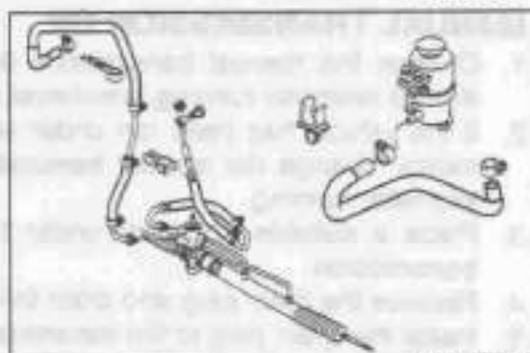

SHOCK ABSORBERS

1. Perform checking every year or 20,000 kilometer running, whichever comes first.
2. Check the shock absorber for oil leakage and damage.
3. Rock the vehicle with your hands. Check to see if rocking finishes within a short length of time.
4. During this rocking, check that there is no abnormal sound.

NOTE:

- For details, see Section FS and Section RS.



5. Repair or replace any defective parts.

SUSPENSIONS

1. Perform checking every two years or 40,000 kilometer running, whichever comes first.
2. Check the front suspension lower arm for damage and bend.
3. Check the front stabilizer for damage and bend.
4. Check the bolts and nuts at the bracket section for looseness.
5. Check the dust boot of the ball joint section for damage.
6. Repair or replace any defective parts.



WHEEL BEARINGS

1. Perform checking every two years or 40,000 kilometer running, whichever comes first.
2. Jack up the vehicle. Hold the tyre by your hands and rock it in a fore-and-aft direction. If you feel excessive play at your hands, it shows that the bearing is defective. Replace the bearing.

NOTE:

- For details, see Section FS and Section RS.



WHEEL ALIGNMENT

1. Perform checking every two years or 40,000 kilometer running, whichever comes first.

Specified Values:

Camber
Caster
Kingpin angle
Toe-in

NOTE:

- It is impossible to adjust or change the camber, caster, or kingpin angle. If the camber, caster, or kingpin angle does not conform to the specification, check to see if the frame has been damaged. Correct the frame, as required.

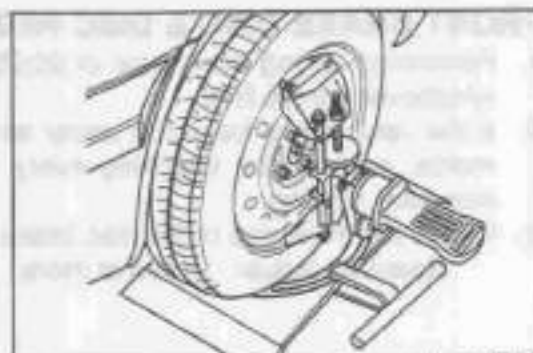

LMA00051-00045

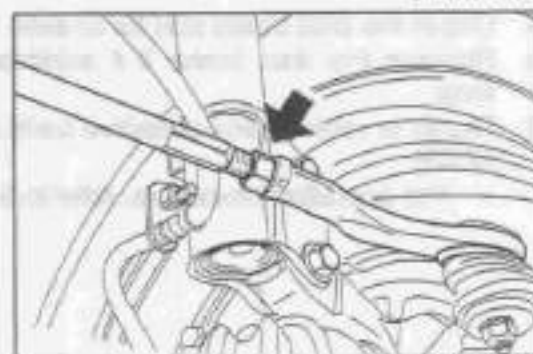

LMA00052-00046

BRAKE PEDAL

1. Perform checking every year or 20,000 kilometer running, whichever comes first.
2. With the engine stopped, depress the brake pedal five times or more so as to eliminate the negative pressure inside the brake booster.
3. Push the brake pedal downward by your hand. Measure the distance between the pedal initial position and the point where resistance begins to be felt.

Specified Value: 0.5 - 5 mm

4. If the measured distance does not conform to the specification, perform the adjustment. For details of the adjustment procedure, refer to Section MT.
5. With the parking brake released, depress the brake pedal with a force of 300 N. Measure the distance between the pedal and the floor surface facing to the pedal.

Specified Values:

R.H.D. vehicles: 77 mm or more
L.H.D. vehicles: 60 mm or more



LMA00053-00047

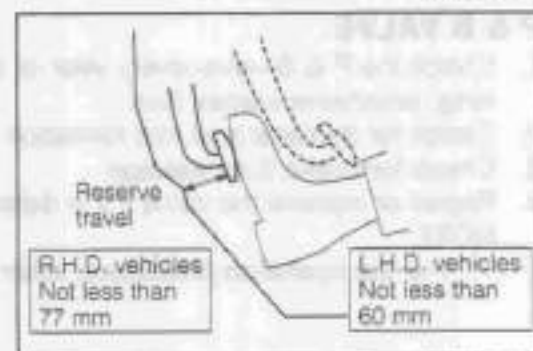

LMA00054-00048

PARKING BRAKE

1. Perform checking every year or 20,000 kilometer running, whichever comes first.
2. With the parking brake lever completely released, pull up the lever with a force of 196 N. Count how many times the clicking sound of the notch takes place from the initial position, until the lever stops. The parking brake is normal if the click sound takes place four to seven times.
3. Perform the adjustment, as required.

NOTE:

- For the adjustment procedure, refer to Section BR.

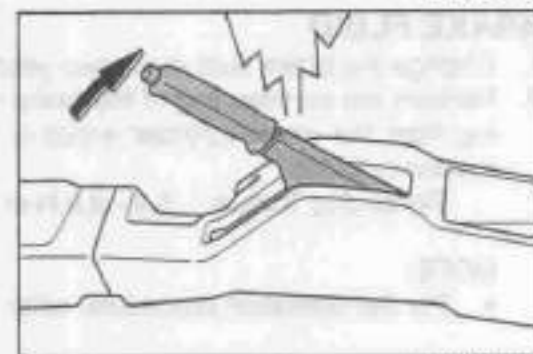

LMA00055-00049

MA-16

FRONT BRAKE DISC & DISC PAD

1. Perform checking every year or 20,000 kilometer running, whichever comes first.
2. If the vehicle has been run under severe driving environments, perform the checking every six months or 5,000 kilometer running.
3. Check the thickness of the disc brake pad.
Specified Value: 1 mm or more

4. Check the disc brake pad for uneven wear.
5. Replace the disc brake if it exhibits damage or severe wear.
6. Repair or replace any defective parts.

NOTE:

- For operation procedure, refer to Section BR.

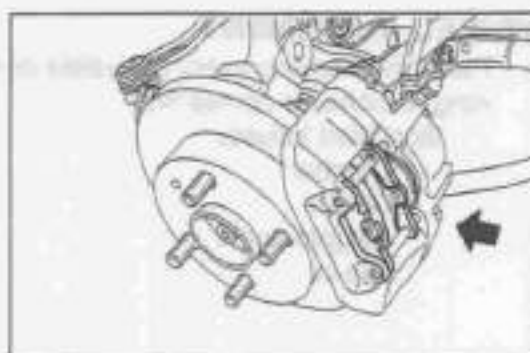

LMA00056-0000

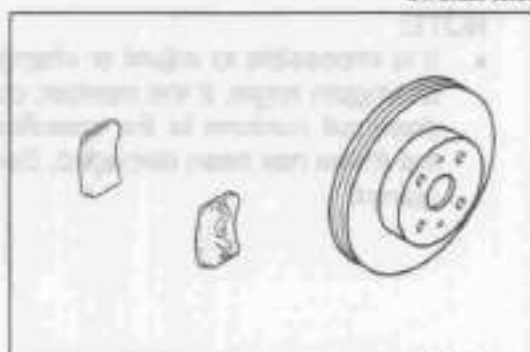

LMA00057-0001

BRAKE HOSES & TUBES

1. Check the brake hose and tube every year or 20,000 kilometer running, whichever comes first.
2. Check the hose for cracks and other defects.
3. Check the tube for damage and rust formation.
4. Check for brake fluid leakage.



LMA00058-0002

P & B VALVE

1. Check the P & B valve every year or 20,000 kilometer running, whichever comes first.
2. Check for damage and rust formation.
3. Check for brake fluid leakage.
4. Repair or replace the valve if it is defective.

NOTE:

- For the operation procedure, refer to Section BR.

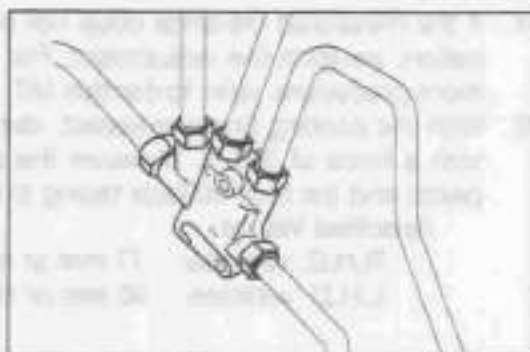

LMA00059-0003

BRAKE FLUID

1. Change the brake fluid every two years.
2. Perform the air bleeding of the brake hydraulic pipe, starting from the wheel cylinder which is the farthest from the master cylinder.

Tightening Torque: 6.9 - 9.8 N·m (Air bleeder plug)

NOTE:

- For the operation procedure, refer to Section BR.

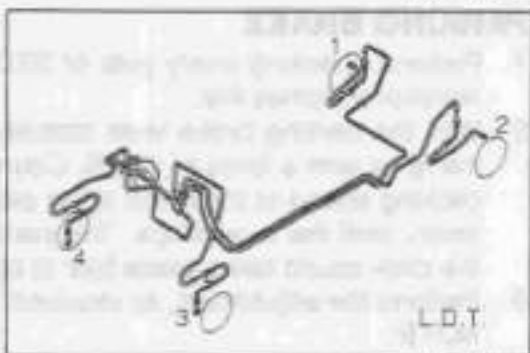

L.D.T.

LMA00060-0004

BRAKE DRUMS & LININGS

1. Check the brake drum and lining every year or 20,000 kilometer running, whichever comes first.
2. If the vehicle has been run under severe driving environments, perform the checking every six months or 5,000 kilometer running, whichever comes first.
3. Remove the brake drum and check the brake lining for uneven wear.
4. Check the thickness of the brake lining.
Specified Value: 1 mm or more

5. Replace the brake drum if it exhibits damage or severe wear.
6. If there are defects, repair or replace.

NOTE:

- For the operation procedure, refer to Section BR.

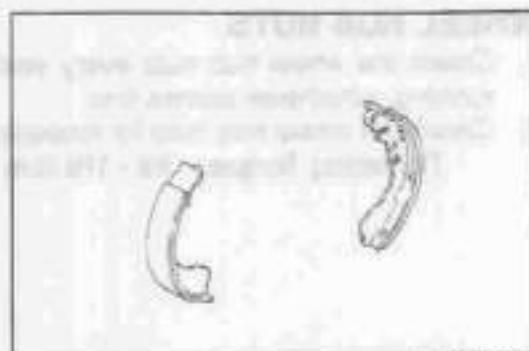

LMA00061-00055

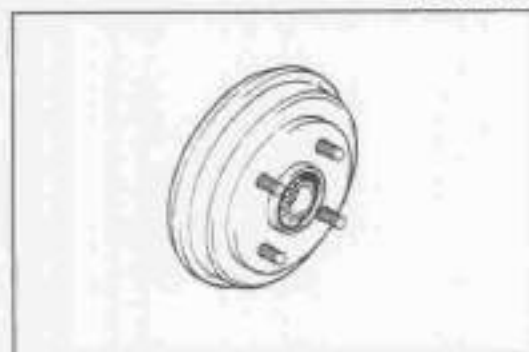

LMA00062-00056

BRAKE BOOSTER VACUUM HOSES

1. Check the brake booster vacuum hose every four years.
2. Check the vacuum hose for damage and cracks.
3. Check the vacuum hose for restriction and leakage, using a MityVac.
4. If there are defects, clean or replace.

CAUTION:

- When replacing the vacuum hose, be sure to use new hose bands.

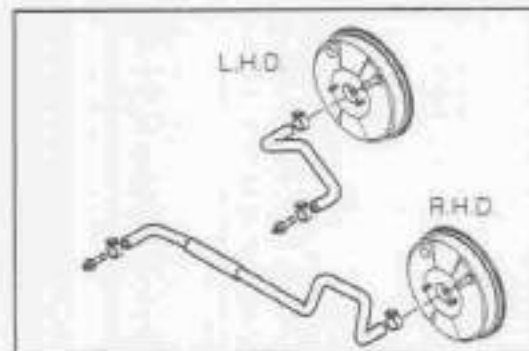

LMA00063-00057

MASTER CYLINDER

1. Check the master cylinder every two years.
2. Remove the master cylinder from the booster. Check the master cylinder for brake fluid leakage.
3. Check the master cylinder piston for wear. Also check the cup for damage or deterioration.
4. Repair or replace any defective parts.

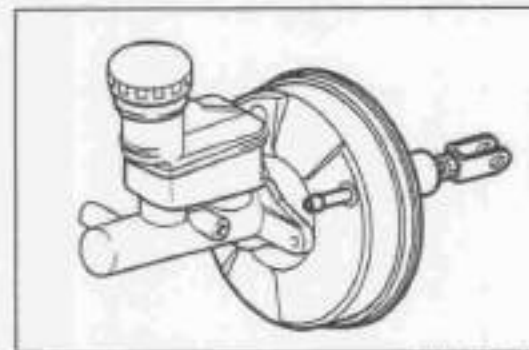

LMA00064-00058

WHEEL CYLINDERS

1. Check the wheel cylinders every two years.
2. Check the wheel cylinder for brake fluid leakage.
3. Check the wheel cylinder boot for damage.
4. Check the wheel cylinder piston for wear. Also check the cup for damage or deterioration.
Repair or replace any defective parts.

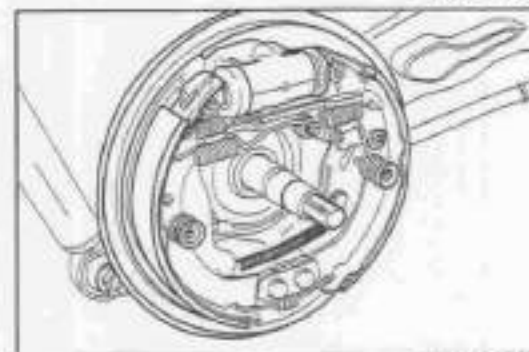

LMA00065-00059

MA-18

WHEEL HUB NUTS

1. Check the wheel hub nuts every year or 20,000 kilometer running, whichever comes first.
2. Check the wheel hub nuts for looseness.

Tightening Torque: 89 - 118 N-m

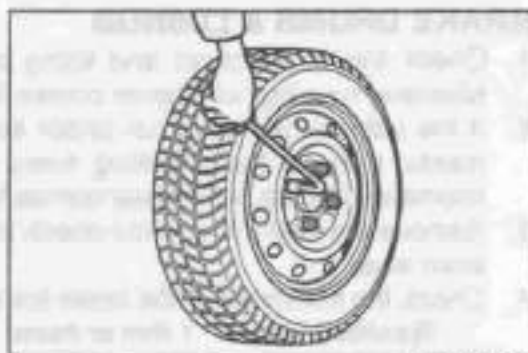

LM40006-0006



BRAKE BOOSTER VACUUM HOSE

1. Check the brake booster vacuum hose for leaks.
2. Check the vacuum hose for cracks and wear.
3. Check the vacuum hose for proper fit.
4. Check the vacuum hose for proper connection.

WATER CYLINDER

1. Check the water cylinder for leaks.
2. Check the water cylinder for cracks and wear.
3. Check the water cylinder for proper fit.
4. Check the water cylinder for proper connection.

WHEEL CYLINDERS

1. Check the wheel cylinders for leaks.
2. Check the wheel cylinders for cracks and wear.
3. Check the wheel cylinders for proper fit.
4. Check the wheel cylinders for proper connection.