



Maintenance Amarok 2011 ➤

Edition 01.2011





Maintenance

Heading

1. Engine list
2. Service work
3. General
4. Descriptions of work
5. Exhaust emissions test
6. Glossary



Technical information should always be available to the foremen and mechanics, because their careful and constant adherence to the instructions is essential to ensure vehicle road-worthiness and safety. In addition, the normal basic safety precautions for working on motor vehicles must, as a matter of course, be observed.

All rights reserved.
No reproduction without prior agreement from publisher.



Contents

1	Engine list	1
2	Service work	2
2.1	Information on LongLife service and time or distance dependent service	2
2.2	Service tables, inland	5
2.3	Service tables, export	6
2.4	Service tables, Argentina and Brazil	9
2.5	VW engine oil standards	10
2.6	Delivery inspection	10
2.7	Scopes of service	12
2.8	Time or distance dependent additional work	15
2.9	Market specific deviations - scope of work for Argentina and Brazil	17
3	General	19
3.1	Vehicle identification number (chassis number)	19
3.2	Vehicle data sticker	19
3.3	Severe operating conditions	20
3.4	Engine code and engine number	20
3.5	Sticker	20
3.6	Entries in service schedule	22
3.7	RME fuel (biodiesel) that does not conform with the standard	22
4	Descriptions of work	24
4.1	Lifting vehicle	25
4.2	Swivel joints: Visual check	44
4.3	Reading ash mass (saturation level) of diesel particulate filter	45
4.4	Battery: Check battery terminal clamps for secure seating	47
4.5	Battery: Perform visual check and check magic eye	51
4.6	Removing relay for battery disconnection	51
4.7	Front passenger front airbag: Check key switch and „On/Off function“	55
4.8	Checking tyres: Condition, wear pattern, tyre pressure, tread depth	56
4.9	Brake system: Perform visual check for leaks and damage	60
4.10	Front brake pads/linings: Check thickness	61
4.11	Rear drum brake linings: Check thickness	64
4.12	Brake system and shock absorbers: Perform visual check for leaks and damage	65
4.13	Brake fluid: Change	65
4.14	Brake fluid level: Check	69
4.15	Climatronic: Set temperature to 22 °C	70
4.16	Window regulators: Check positioning (open and close functions)	71
4.17	Connecting vehicle diagnosis tester	71
4.18	Performing vehicle system test	74
4.19	Four-wheel drive: Insert fuse	77
4.20	Protective bellows: Visual check	80
4.21	Dust and pollen filter: Clean housing and renew filter element	80
4.22	Poly V-belt: Check condition	81
4.23	High pressure pump: Check	82
4.24	Poly V-belt: Renew	82
4.25	Fuel filter: Renew (diesel engine)	82
4.26	Fuel system: Bleed (diesel engine)	83
4.27	Fuel filter: Drain water (diesel engine)	84
4.28	Cooling system: Check frost protection and coolant level	84
4.29	Air filter: Clean housing and renew filter element	88
4.30	Air filter with saturation indicator in dash panel insert:	90
4.31	Resetting programmed values in engine control unit	90
4.32	Engine oil level: Check	91
4.33	Engine oil: Drain or extract; renew oil filter and replenish engine oil	91



4.34	Engine and components in engine compartment (from above and below): Perform visual check for leaks and damage	95
4.35	Bonnet catch: Clean, ensure attachment is secure and lubricate	96
4.36	Check breakdown set	96
4.37	Performing road test	97
4.38	Wheel securing bolts: Tighten to specified torque	98
4.39	Reading radio code	99
4.40	Radio / radio navigation system: Enter anti-theft coding PIN	101
4.41	Radio navigation system: Insert navigation CD/DVD and perform update	102
4.42	Timing chain: Renew	102
4.43	Windscreen wash/wipe system and headlight washer system: Check function and settings	102
4.44	Windscreen wiper blades: Check park position	105
4.45	Headlight adjustment: Check, if necessary adjust	106
4.46	Service interval display: Reset	109
4.47	Service interval display: Recode (adapt)	111
4.48	Service interval: Adjusting (inland)	112
4.49	Service interval: Adjusting (export)	117
4.50	Service interval: Adjusting (Argentina and Brazil)	121
4.51	Track rod ends: Check clearance, security and boots	126
4.52	Power assisted steering: Check fluid level	126
4.53	Doors: Grease door arrester	128
4.54	Paint: Perform visual check for damage and corrosion, interior and exterior when doors and bonnet/rear lid/flaps are open	128
4.55	Protective foil: Remove (if fitted)	128
4.56	Underbody protection: Perform visual check for damage	129
4.57	Clock: Set to correct time	129
4.58	Camshaft drive toothed belt and toothed belt tensioning roller: Renew	130
4.59	Camshaft drive toothed belt: Check condition	130
4.60	Coolant pump toothed belt sprocket and toothed belt: Renew	131
4.61	Spark plugs: Renew	131
4.62	Removing and installing skid plate	133
4.63	Steering: Check bellows for leaks and damage	133
5	Exhaust emissions test	134
5.1	General information for exhaust emissions test	134
5.2	Exhaust emissions test for petrol engines with engine code CFPA	135
5.3	Exhaust emissions test for diesel engines with engine codes CDBA, CDCA	142
5.4	Exhaust emissions test with OBD	144
6	Glossary	148



1 Engine list

Diesel engines ⇒ [page 1](#)
Petrol engines ⇒ [page 1](#)

Diesel engines



Note

To ease the search for an engine, the engine codes are listed in alphabetical order.

Engines:	⇒	Diesel engines	Diesel engines
Capacity	l	2,0	2,0
Introduction		WEEK 05/2010 ►	WEEK 05/2010 ►
Engine code		CDBA	CDCA
No. of cylinders/valves per cylinder		4/4	4/4
Output	kW at rpm	90/3750	120/4000
Torque	Nm at rpm	340/1750-2500	400/1500-2000
Bore	∅ mm	81,0	81,0
Stroke	mm	95,5	95,5
Compression ratio		16,5	16,5
Injection/ignition		TDI common rail	TDI common rail
Diesel particulate filter		yes/no ¹⁾	yes/no ¹⁾
Camshaft drive		Toothed belt	Toothed belt

¹⁾ Depending on vehicle equipment

Petrol engines

Engines:	⇒	Petrol engines
Capacity	l	2,0
Introduction		WEEK 42/2010 ►
Engine code		CFPA
No. of cylinders/valves per cylinder		4/4
Output	kW at 1 rpm	118/3800-5500
Torque	Nm at rpm	300/1600-3750
Bore	∅ mm	82,5
Stroke	mm	92,8
Compression ratio		9,6
Injection/ignition		Motronic MED 17.5 TSI turbocharger
Camshaft drive		Chain



2 Service work

- ◆ Information on LongLife service and time or distance dependent service ⇒ [page 2](#)
- ◆ Scopes of service ⇒ [page 12](#)
- ◆ Service tables ⇒ [page 5](#)
- ◆ Delivery inspection ⇒ [page 10](#)
- ◆ Time or distance dependent additional work ⇒ [page 15](#)

2.1 Information on LongLife service and time or distance dependent service

- ◆ LongLife service ⇒ [page 2](#)
- ◆ Service identification ⇒ [page 2](#)
- ◆ Service interval display ⇒ [page 4](#)
- ◆ Time or distance dependent service ⇒ [page 3](#)

2.1.1 Service identification

- Check vehicle data sticker to determine whether the vehicle has production control (PR) number „QG1“, „QG0“ or „QG2“. The PR number is decisive for the service intervals ⇒ [page 5](#).

The vehicle data sticker -arrow- is attached to the left A-pillar lower trim panel in the footwell.

This vehicle data sticker is also found in the service schedule for the customer.

Vehicle ID with PR number

„QG1“ indicates „LongLife service“.

„QG2“ or „QG0“ indicates „time or distance dependent“ service.

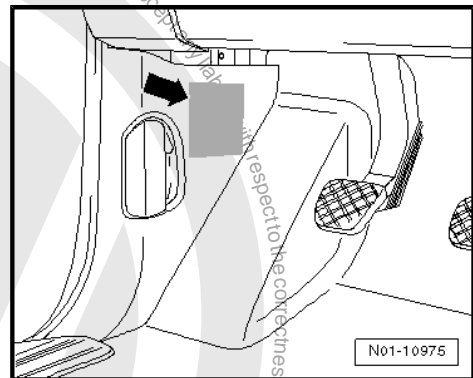

2.1.2 LongLife service

Vehicles with PR number „QG1“

With the LongLife system, a new technology was introduced by Volkswagen commercial vehicles whereby an interval service is only performed when the vehicle needs it.

What is so special about it is that individual conditions of use and personal driving style are taken into consideration when determining the interval service.



Note

If no LongLife engine oil is filled or replenished, the time or distance dependent service applies. A shorter service interval applies in this instance. Information about the different intervals can be gleaned from ⇒ [page 5](#) Service tables, inland.



Note

For the LongLife service a special LongLife engine oil is required
⇒ [page 10](#).

Vehicles with PR number „QG1“ are set up for active LongLife service before they leave the factory. This means that these vehicles have a flexible service interval display and are fitted with the following components:

- ◆ Flexible service interval display in dash panel insert
- ◆ Engine oil level sensor

For vehicles with LongLife service the service interval is determined by the control unit and is indicated on service interval display (SID) ⇒ [page 4](#).

Therefore the service intervals for LongLife service are flexible.

These flexible service intervals are valid for all types of service including an engine oil change.

2.1.3 Time or distance dependent service

On vehicles with time or distance dependent service with PR number „QG0/QG2“ non-flexible service intervals apply.

For normal operating conditions achieving these service intervals is technically assured.

This means that the indicated mileage or time intervals have already been determined and specified by Volkswagen Commercial Vehicles.

Therefore the service intervals for time or distance dependent service are non-flexible.

For vehicles

- ◆ that were delivered without extended service intervals (ESI) (production control number QG0 = without ESI, production control number QG2 = ESI cannot be activated)
 - ◆ When the extended servicing interval (ESI) was stopped
 - ◆ or in which LongLife engine oil has not been used,
- the time or distance dependent service applies.

These flexible service intervals are valid for all types of service including an engine oil change.

Vehicles with PR number „QG0“

These vehicles are „not“ factory-fitted with components for LongLife service. For maintenance the time or distance dependent intervals (non-flexible intervals) apply.

Vehicles with PR number „QG2“

For these vehicles the LongLife service is not factory-activated. Therefore, these vehicles have a non-flexible service interval display (SID) ⇒ [page 4](#) and for maintenance the time or distance dependent intervals (non-flexible intervals) are valid. These vehicles are fitted with the following components:

- ◆ Non-flexible service interval display in dash panel insert
- ◆ Engine oil level sensor





2.1.4 Service interval display

Introduction of extended servicing intervals (ESI)

Ask your importer if the extended servicing interval (ESI) is available for your country.

Flexible service interval display (only vehicles with LongLife service, production control number QG1)

Calculation of service intervals:

- ◆ To calculate the service intervals for vehicles with LongLife service, input values such as distance driven, fuel consumption, oil temperature and load of diesel particulate filter are evaluated.
- ◆ The result of the evaluation is a measure of the deterioration of the oil due to thermal load.
- ◆ Oil deterioration is the decisive factor in determining the distance that can still be driven before the next service.



Note

For vehicles with LongLife service (PR number QG1) but which are serviced according to time or distance dependent intervals, the service interval display need not be recoded to „non-flexible“ => [page 111](#).

Non-flexible service interval display (only vehicles with time or distance dependent service, PR number „QG0/QG2“)

Calculation of service intervals:

- ◆ The service interval for vehicles with time-dependent or mileage-dependent service is calculated in so-called non-flexible service intervals.
- ◆ This means that the mileage or time values have been previously determined and specified by Volkswagen.
- ◆ For normal operating conditions achieving these service intervals is technically assured.

Servicing when service is due

- ◆ When a service is due, „Service“ or „Service now“ appears on the „trip recorder“ on the dash panel insert display or on the display for various kinds of information in the dash panel insert.

The service messages disappear after a few seconds or if the engine is running.

Service initial warning

If a service is due, an „advance service warning“ appears on the dash panel insert display when the ignition is switched on.

- ◆ The dash panel insert display shows the »symbol of a workshop spanner« and a km number.

The service messages disappear after a few seconds or if the engine is running.

- ◆ The remaining distance displayed is always rounded to the nearest 100 km or the remaining time rounded to full days.

Requesting service information.

The current service information can be requested at any time with the ignition switched on, the engine turned off and the vehicle at a standstill.



- Press button -A- in dash panel insert four times until „spanner symbol“ appears in dash panel insert -B-.
- ◆ On the dash panel insert display, an overdue service is indicated by a minus sign in front of the mileage or day information.



Note

Service message goes out after a few seconds or when button -A- is pressed.

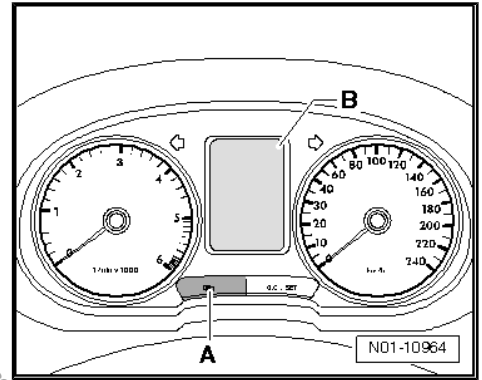

2.2 Service tables, inland

- ◆ Service intervals ⇒ [page 5](#)

2.2.1 Service intervals

To ensure that every service is carried out at the right time and that no service is forgotten, a service sticker on the door pillar or the service interval indicator on the display of the dash panel insert serves as a reminder.

Information about service sticker is displayed at ⇒ [page 20](#) .



Caution

- ◆ **Diesel engines:** In some regions, elevated sulphur content may be evident. The high sulphur content leads to excessive wear of cylinders and it considerably reduces the cleanliness of pistons. Short service intervals apply in this instance.



Note

Depending on the conditions of use and the vehicle's equipment, extra service work must be performed in addition to the inspection service or oil change service ⇒ [page 15](#) .



Amarok			
Service intervals, inland 2010 ►			
From to	Engine/ Engine code/ PR No./Remarks	Service: Intervals	Indication on SID (with oil change) ⇒ page 4
2010 ►	QG0/QG2 or QG1 vehicles coded to fixed intervals	Oil change service every 10,000 km ¹⁾ diesel engines	YES
		Oil change service every 15,000 km, petrol engines	YES
		Oil change service every 20,000 km or 1 year ¹⁾ diesel engines	YES
		Interval service max. 40,000km or 2 years ¹⁾	YES
	QG1 vehicles	Interval service max. 30,000km or 2 years ²⁾ , petrol engines	YES
		Interval service max. 40,000 km or 2 years ¹⁾ diesel engines	YES
	All vehicles	First inspection service after 3 years, then every 2 years	NO

1) Vehicles with elevated sulphur content in diesel fuel.

2) Whichever occurs first

2.3 Service tables, export

- ◆ Service intervals depending on sulphur content in fuel
⇒ [page 7](#)

2.3.1 Service intervals

To ensure that every service is carried out at the right time and that no service is forgotten, a service sticker on the door pillar or the service interval indicator on the display of the dash panel insert serves as a reminder.

 **Caution**

- ◆ *Diesel engines: In some countries, the sulphur content in the diesel fuel deviates from the EN590 standard. The elevated sulphur content leads to increased wear in the cylinders and impairs piston cleanliness considerably. Short service intervals apply in this instance.*
- ◆ *To find out which countries have increased sulphur content in the diesel fuel, see ⇒ [page 7](#).*

Note

Depending on the conditions of use and the vehicle's equipment, extra service work must be performed in addition to the inspection service or oil change service.



Amarok			
Service interval, export 2010 ►			
From to	Engine/ Engine code/ PR No./Remarks	Service: Intervals	Indication on SID (with oil change)
2010 ►	QG0/QG2 or QG1 vehicles coded to fixed intervals	Oil change service ¹⁾ ⇒ page 7	YES
		Interval service max. 40,000km or 2 years ²⁾	YES
	QG1 vehicles	Interval service max. 30,000km or 2 years ²⁾ , petrol engines	YES
		Interval service max. 40,000 km or 2 years ²⁾ diesel engines	YES
All vehicles	First inspection service after 3 years, then every 2 years	NO	

1) For oil change service intervals, please refer to table specified for relevant country.

2) Whichever occurs first

2.3.2 Oil change intervals depending on sulphur content in fuel

Oil change intervals depending on sulphur content in fuel					
Fuel quality	(EN590)	◀ 500 ppm	500-2,000 ppm	2,000-4,000 ppm	► 4,000 ppm
Change interval	ESI	20,000 km	10,000 km	7,500 km	5,000 km
Turkey		X ^{1) 2)}			
Norway	X				
Iceland	X				
Switzerland	X				
Croatia		X ²⁾			X ¹⁾
Albania				X	
Macedonia	X ²⁾		X ¹⁾		
Montenegro	X ²⁾			X ¹⁾	
Serbia					X
Bosnia-Herzegovina					X
RUS	X ³⁾		X East ¹⁾	X (West)	
Belarus	X ¹⁾				
Ukraine			X ^{1) 2)}		
Moldova				X	
Armenia			X		
Azerbaijan			X		
Georgia			X ^{1) 2)}		
Kazakhstan				X	
Kirghizia			X		
Mongolia				X	
Turkmenistan			X		
Uzbekistan				X	



Oil change intervals depending on sulphur content in fuel					
Fuel quality	(EN590)	◀ 500 ppm	500-2,000 ppm	2,000-4,000 ppm	▶ 4,000 ppm
Change interval	ESI	20,000 km	10,000 km	7,500 km	5,000 km
Mexico			X		
Chile	X				
Venezuela					X
Columbia				X	
Ecuador				X	
Surinam				X	
Peru					X
Bolivia				X	
Paraguay				X	
Uruguay				X	
France overseas territories and departments	X				
Caribbean				X	
Israel	X				
Bahrain					X
Qatar			X		
Kuwait				X	
Oman			X		
Saudi Arabia					X
United Arab Emirates					X
Africa				X	
Kenya					X
Algeria			X		
Libya			X		
Tunisia	X 4)			X 1)	
Egypt					X
Morocco					X
Ivory Coast				X	
Ghana				X	
Mauritius				X	
Mali				X	
Nigeria				X	
Senegal				X	
Zimbabwe				X	
Tanzania				X	
Tajikistan				X	
Uzbekistan				X	
Dominican Republic				X	
Guatemala				X	
Honduras				X	
Trinidad and Tobago					X
Gabon					X
Madagascar					X
Iraq					X



Oil change intervals depending on sulphur content in fuel					
Fuel quality	(EN590)	◀ 500 ppm	500-2,000 ppm	2,000-4,000 ppm	▶ 4,000 ppm
Change interval	ESI	20,000 km	10,000 km	7,500 km	5,000 km
Iran					X
Jordan					X
Lebanon					X
Syria					X
El Salvador					X
Jamaica					X
Cuba					X
Panama					X

- 1) Local diesel
- 2) Euro diesel
- 3) Eco diesel
- 4) Podium

2.4 Service tables, Argentina and Brazil

◆ Service interval ⇒ [page 9](#)

2.4.1 Service intervals

To ensure that every service is carried out at the right time and that no service is forgotten, a service sticker on the door pillar or the service interval indicator on the display of the dash panel insert serves as a reminder.

Information about service sticker is displayed at ⇒ [page 20](#) .

Amarok			
Service intervals, Brazil/Argentina 2010			
From to	Engine/ Engine code/ PR No./Remarks	Service: Intervals	Indication on SID (with oil change)
2010 ►	QG0/QG2 or QG1 vehicles coded to fixed intervals	Initial oil change service at 5,000 km, then every 10,000 km ¹⁾	YES
		Oil change service every 10,000 km or 6 months ²⁾	YES

- 1) Adapt service interval to respective distance-based interval.
- 2) Whichever occurs first



2.5 VW engine oil standards



Note

- ◆ For vehicles with LongLife service (PR number QG1) that are serviced according to time or distance dependent intervals, the service interval display does not have to be recoded to „non-flexible“.
- ◆ Only engine oils approved by Volkswagen Commercial Vehicles may be used. Up-to-date information ⇒ Volkswagen Commercial Vehicles ServiceNet, Technical information, Inspections and servicing, Approved oils

Amarok			
VW ENGINE OIL STANDARDS			
With LongLife service (QG1)		Without LongLife service (QG0, QG2)	
PETROL ENGINE			
4-cylinder	504 00 alternative 503 00	4-cylinder	504 00 alternative 501 01 / 502 00
DIESEL ENGINES			
4-cylinder (with Bosch EDC 17 TDI common rail with die- sel particulate filter)	507 00 ¹⁾ 505 01 ²⁾	4-cylinder (with Bosch EDC 17 TDI common rail with die- sel particulate filter)	507 00 ¹⁾ 505 01 ²⁾
4-cylinder (with Bosch EDC 17 TDI common rail without diesel particulate filter)	507 00 ¹⁾ 505 01 ²⁾	4-cylinder (with Bosch EDC 17 TDI common rail without diesel particulate filter)	507 00 ¹⁾ 505 01 ²⁾

1) Only for markets where diesel complies with EN 590.

2) Only for markets with elevated sulphur content in diesel fuel.

Further engine oils of other suppliers approved by Volkswagen commercial vehicles can be found in ⇒ Volkswagen Commercial Vehicles ServiceNet, Technical information, Inspections and Servicing, Approved oils

2.6 Delivery inspection

- ◆ The sequence of the individual service tasks has been tested and optimised. The sequence must be followed in order to avoid unnecessary interruptions in work.

Work to be completed	Page
Electrics	
◆ Battery isolator relay (if fitted): Remove (remove and return to manufacturer) • Vehicles with transport equipment	⇒ page 51
◆ Battery: Check battery terminal clamps by hand for tightness	⇒ page 47
◆ Battery: Perform visual check and check magic eye (if fitted)	⇒ page 51
◆ Four-wheel drive fuse: Insert (PR number „1x1“)	⇒ page 77
◆ Vehicle system test: Perform	⇒ page 74



Work to be completed	Page
◆ Radio code: Request (customer should be informed of radio code IF DESIRED)	⇒ page 99
Vehicle interior	
◆ All switches, electrical consumers, sockets, gauges and other control elements: Check function	
◆ Door handles, door locks, central locking and windows: Check function and ease of movement	
◆ Front passenger airbags: Check key switch and „ON/OFF function“, set switch to „ON“	⇒ page 55
◆ Window regulators: Check positioning (open and close functions)	⇒ page 71
◆ Clock: Set to correct time	⇒ page 129
◆ Climatronic: Set temperature to 22 °C	⇒ page 70
◆ Transportation mode: Switch off	
◆ Radio/radio navigation system: Activate anti-theft coding, store local radio stations to station buttons	⇒ page 101
◆ Radio navigation system: Insert navigation CD/DVD and perform update	⇒ page 102
◆ Seat protective covers and protective foils: Remove	
◆ Vehicle interior: Check for cleanliness (front and rear seats, interior trim, carpets/mats, windows)	
Vehicle exterior	
◆ All equipment that has been introduced to the vehicle (mats, wipers, spoilers, roof aerial, full sized wheel trims/wheel trims, wheel bolt covers, tyre valve extensions): Install (if featured)	
◆ Edge protection on doors (plastic foil): Remove	
◆ Vehicle exterior: Check for cleanliness (paintwork, decorative parts, windows, wiper blades, surfaces)	
◆ Protective foil: Remove (if fitted)	⇒ page 128
Tyres	
◆ Spare wheel tyre: Check condition and inflation pressure (if fitted)	⇒ page 56
◆ Front left tyre: Check condition and inflation pressure	⇒ page 56
◆ Rear left tyre: Check condition and inflation pressure	⇒ page 56
◆ Rear right tyre: Check condition and inflation pressure	⇒ page 56
◆ Front right tyre: Check condition and inflation pressure	⇒ page 56
◆ Wheel securing bolts: Tighten to specified torque	⇒ page 98
Vehicle, bottom	
◆ Vehicle from below (without removing underbody protection): Perform visual check for leaks and damage	⇒ page 129 ⇒ page 80
◆ Engine, CV joint boots/bellows, brake system, steering, axles, gearbox/final drive, hoses, fluid reservoirs/containers	
◆ Vehicle underside (floor pan): Perform visual check for damage	⇒ page 129



Work to be completed	Page
◆ Brake system: Perform visual check for leaks and damage	⇒ page 60
Engine compartment	
◆ Engine and components in engine compartment (from above): Perform visual check for leaks and damage	⇒ page 95
◆ Window wash/wipe system and headlight washer system: Check function and settings; replenish to maximum level	⇒ page 102
◆ Engine oil level: Check (observe VW engine oil standards if replenishing)	⇒ page 91
◆ Coolant level: Check level is at maximum	⇒ page 84
◆ Brake fluid: Change • For stock vehicles and vehicles in storage whose standing period of 6 months or more, the brake fluid must be renewed.	⇒ page 65
◆ Brake fluid level: Check level is at maximum	⇒ page 69
◆ Power assisted steering: Check fluid level	⇒ page 126
Documentation/final checks	
◆ Number and function of keys: Check, wipe off grease if necessary	
◆ Vehicle data sticker: Stick into service schedule and in vehicle	⇒ page 21
◆ Service schedule: Enter delivery inspection, enter a cross for the 1st service and complete vehicle data in service schedule, see „Vehicle delivery documentation“	
◆ Interval service for vehicles with LongLife service (PR No. QG1) ¹⁾	
◆ Oil change service for vehicles with time or distance dependent service (PR No. QG0/QG2) ¹⁾	
◆ Vehicle literature: Check literature is complete and prepare for handover to customer	
◆ Service interval display: Reset (observe „2024733“)	⇒ page 109
◆ Road test: Perform	⇒ page 97

1) Service identification ⇒ [page 2](#)

2.7 Scopes of service



Note

The various types of service can be combined under certain circumstances (oil change or interval service in conjunction with an inspection service). Whereupon doubly listed activities are only charged once.



Note

Observe notes for oil change service, interval service and inspection service on ⇒ [page 3](#).

- ◆ Depending on the vehicle equipment and the conditions under which the vehicle is used, additional maintenance measures



may need to be performed when services are due
⇒ [page 15](#) .

- ◆ It is possible to have additional work done outside the service intervals, with account being taken of the entries in the service schedule (or service sticker: „Your next service dates“).



Caution

- ◆ *Diesel engines: In some regions/countries, an elevated sulphur content may be evident in the diesel fuel. This leads to increased wear of the cylinders and impairs piston cleanliness considerably. Short service intervals therefore apply in this instance ⇒ [page 7](#) .*

 **Note**

If faults are found within the scope of servicing which make repair measures necessary, the customer must be informed and the additional work invoiced separately where necessary.

- ◆ Abbreviations for scopes of service:
- ◆ 1) Oil: Oil change service, 2) Int.: Interval service,
- ◆ 3) Insp.: Inspection service

Oil 1)	Int. 2)	Insp. 3)	Measure
Electrics			
		X	◆ Front lights - Side lights, dipped beam, main beam, fog lights, turn signals, hazard warning lights: Check function
		X	◆ Rear lights - brake lights (including 3rd brake light), tail lights, reversing lights, rear fog light, number plate light, turn signals, hazard warning lights: Check function
		X	◆ Interior, luggage and glove compartment lights, cigarette lighter, sockets, horn and warning lamps: Check function
	X		◆ Battery: Perform visual check and check magic eye ⇒ page 51
Vehicle exterior			
		X	◆ Doors: Grease door arrester ⇒ page 128
		X	◆ Windscreen wash/wipe system, spray jet settings: Check function and for damage, adjust as necessary
		X	◆ Wiper blades: Check for damage and park position, adjust as necessary ⇒ page 105
		X	◆ Paint: Perform visual check for damage and corrosion, interior and exterior when doors and bonnet/rear lid/flaps are open ⇒ page 128
	X		• Bonnet catch: Clean, ensure attachment is secure and lubricate ⇒ page 96
Tyres			



Oil 1)	Int. 2)	Insp. 3)	Measure
	X		<ul style="list-style-type: none"> ◆ Tread depth, condition, wear pattern, age, inflation pressure (including spare tyre): Check, rectify as necessary ⇒ page 56
Vehicle from below			
		X	<ul style="list-style-type: none"> ◆ Engine and components in engine compartment (from below): Visual check for leaks and damage ◆ Gearbox, final drive and drive shaft bellows ⇒ page 95
		X	<ul style="list-style-type: none"> ◆ Underbody: Visual check for damage to underbody protection and underbody trim/panels ⇒ page 129
		X	<ul style="list-style-type: none"> ◆ Exhaust system: Visual check for leaks, security and damage
		X	<ul style="list-style-type: none"> ◆ Check track rod ends: ⇒ page 126 <ul style="list-style-type: none"> ◆ play, attachment and damage to boots/bellows
		X	<ul style="list-style-type: none"> ◆ CV joints, axial bearings, coupling rod bearings and anti-roll bar rubber bushes: Visual check for damage ⇒ page 44
	X		<ul style="list-style-type: none"> ◆ Brake system: Perform visual check for leaks and damage ⇒ page 60
X	X		<ul style="list-style-type: none"> ◆ Thickness of front and rear brake pads/linings: Check ⇒ page 61
Engine compartment			
		X	<ul style="list-style-type: none"> ◆ Engine and components in engine compartment (from above): Perform visual check for leaks and damage ⇒ page 95
X	X		<ul style="list-style-type: none"> ◆ Engine oil: Change and replace oil filter, ensure level is at maximum after filling system and replenish if necessary ⇒ page 91 <ul style="list-style-type: none"> • Note VW engine oil standards ⇒ page 10
		X	<ul style="list-style-type: none"> ◆ Brake fluid: Change (after 3 years from initial registration and then every 2 years) ⇒ page 65
	X		<ul style="list-style-type: none"> ◆ Brake fluid level (depending on lining wear): Check (observe specification ⇒ page 69) ⇒ page 69
		X	<ul style="list-style-type: none"> ◆ Brake system and shock absorbers: Perform visual check for leaks and damage ⇒ page 65
	X		<ul style="list-style-type: none"> ◆ Power assisted steering: Check fluid level ⇒ page 126
	X		<ul style="list-style-type: none"> ◆ Air filter with saturation indicator in dash panel insert: Check ⇒ page 90
		X	<ul style="list-style-type: none"> ◆ Cooling system: Check frost protection and coolant level, replenish if necessary ⇒ page 84 <ul style="list-style-type: none"> • Specified antifreeze value: „-25 °C“ In countries with an arctic climate „-35 °C“
Final checks			



Oil 1)	Int. 2)	Insp. 3)	Measure
		X	◆ Headlights: Check adjustment ⇒ page 106
		X	◆ Vehicle system test: Perform ⇒ page 74
X	X		◆ Service interval display: Reset (observe „2024733“) ⇒ page 109
X	X	X	◆ „Your next service“ sticker: Enter next due date ¹⁾ and attach service sticker to driver side door pillar (B-pillar) ⇒ page 20
		X	◆ Breakdown set (if fitted): Check (renew tyre inflation bottle with sealant if use-by date has expired) ⇒ page 96
X		X	◆ Road test: Perform ⇒ page 97

2.8 Time or distance dependent additional work

- ◆ Depending on conditions under which the vehicle is used and vehicle equipment, extra service work must be performed in addition to the inspection service or oil change service/interval service. These additional maintenance measures are invoiced separately and are marked as extra work.

Measure:	Interval
◆ Thickness of front ⇒ page 61 and rear ⇒ page 64 brake pads/linings: Check	Recommendation: ¹⁾
◆ Fuel filter: Renew – if vehicle runs on diesel fuel • that does not conform with the standard „DIN EN 590“ • and has an elevated sulphur content (>2000 ppm) ⇒ page 82	Every 10,000 km
◆ Fuel filter: Drain water - if vehicle runs on diesel fuel • that does not conform with the standard „DIN EN 590“ ⇒ page 84	Every 20,000 km
◆ Camshaft drive toothed belt: Check • Valid in „dusty“ regions, diesel engines ⇒ page 130	Every 40,000 km
◆ Fuel filter: Renew – if vehicle runs on diesel fuel • that does not conform with the standard „DIN EN 590“ ⇒ page 82	



Measure:	Interval
<ul style="list-style-type: none"> ◆ Dust and pollen filter (cabin filter): Clean housing and renew filter element <p>⇒ page 80</p>	Every 60,000 km
<ul style="list-style-type: none"> ◆ Spark plugs: Renew <p>⇒ page 131</p>	
<ul style="list-style-type: none"> ◆ Air filter: Clean housing and renew filter element (reset learnt values of engine control unit -J623-) ◆ Valid in „dusty“ regions, petrol engines <p>⇒ page 88</p>	
<ul style="list-style-type: none"> ◆ Fuel filter: Renew – if vehicle runs on diesel fuel <p>⇒ page 82</p>	Every 80,000 km
<ul style="list-style-type: none"> ◆ Air filter: Clean housing and renew filter element (reset learnt values of engine control unit -J623-) <p>⇒ page 88</p>	Every 120,000 km
<ul style="list-style-type: none"> ◆ Camshaft drive toothed belt and toothed belt tensioning roller: Renew • Valid in „dusty“ regions, diesel engines <p>⇒ page 130</p>	
<ul style="list-style-type: none"> ◆ Poly V-belt: Check condition <p>⇒ page 81</p>	
<ul style="list-style-type: none"> ◆ Fuel filter: Renew – if vehicle runs on diesel fuel • Conforming to „DIN EN 590“ <p>⇒ page 82</p>	
<ul style="list-style-type: none"> ◆ Diesel particulate filter (if fitted): Interrogate ash mass (saturation level) <p>⇒ page 45</p>	
<ul style="list-style-type: none"> ◆ Poly V-belt: Renew • Applies for petrol engines <p>⇒ page 82</p>	Every 180,000 km
<ul style="list-style-type: none"> ◆ Coolant pump toothed belt and toothed belt sprocket: Renew • Applies for petrol engines <p>⇒ page 131</p>	Every 210,000 km
<ul style="list-style-type: none"> ◆ Camshaft drive toothed belt and toothed belt tensioning roller: Renew • Valid for diesel engines <p>⇒ page 130</p>	
<ul style="list-style-type: none"> ◆ High pressure pump: Check • Applies for petrol engines <p>⇒ page 82</p>	
<ul style="list-style-type: none"> ◆ Timing chain: Renew • Applies for petrol engines <p>⇒ page 102</p>	Every 300,000 km



Measure:	Interval
<ul style="list-style-type: none"> ◆ Camshaft drive toothed belt: Check • Valid in „dusty“ regions, diesel engines <p>⇒ page 130</p>	Every 2 years
<ul style="list-style-type: none"> ◆ Dust and pollen filter (cabin filter): Clean housing and renew filter element <p>⇒ page 80</p>	
<ul style="list-style-type: none"> ◆ Air filter: Clean housing and renew filter element (reset learnt values of engine control unit -J623-) ◆ Valid in „dusty“ regions, petrol engines <p>⇒ page 88</p>	Every 3 years
<ul style="list-style-type: none"> ◆ Emissions test: Perform (every 12 months in Germany for commercial passenger transport, e.g. taxis) <p>⇒ page 134</p>	3 years after initial registration and then every 2 years
<ul style="list-style-type: none"> ◆ Fuel filter: Renew – if vehicle runs on diesel fuel • that does not conform with the standard „DIN EN 590“ <p>⇒ page 82</p>	Every 4 years
<ul style="list-style-type: none"> ◆ Spark plugs: Renew <p>⇒ page 131</p>	
<ul style="list-style-type: none"> ◆ Air filter: Clean housing and renew filter element – Resetting programmed values in engine control unit -J623- <p>⇒ page 88</p>	Every 6 years
<ul style="list-style-type: none"> ◆ Fuel filter: Renew – if vehicle runs on diesel fuel • Conforming to „DIN EN 590“ <p>⇒ page 82</p>	

1) Wear on brake linings is heavily dependent on operating conditions and driving style. If urban and short-distance driving are common as well as if there is a sporty driving style, Volkswagen recommends having the thickness of the brake linings checked in the workshop more often than specified in the service schedule.

2.9 Market specific deviations - scope of work for Argentina and Brazil



Note

In this chapter you will find only market-specific deviations for Argentina and Brazil. In other words, all of the service intervals not listed here should be gleaned from the normal service interval tables.



Deviations in scope of work relating to oil change, interval and inspection service

Additional work	Page
◆ Toothed belt and tensioning roller for camshaft drive: Check ⇒ page 130 <ul style="list-style-type: none">• Not with oil change service	
◆ Windscreen wiper blades: Check for damage ⇒ page 105	
◆ Expiry date of contents in first aid box: Check	

Every 2 years

Additional work	Page
◆ Brake fluid: Change (observe specification ⇒ page 69) ⇒ page 65 <ul style="list-style-type: none">• Check if brake fluid service is due.	

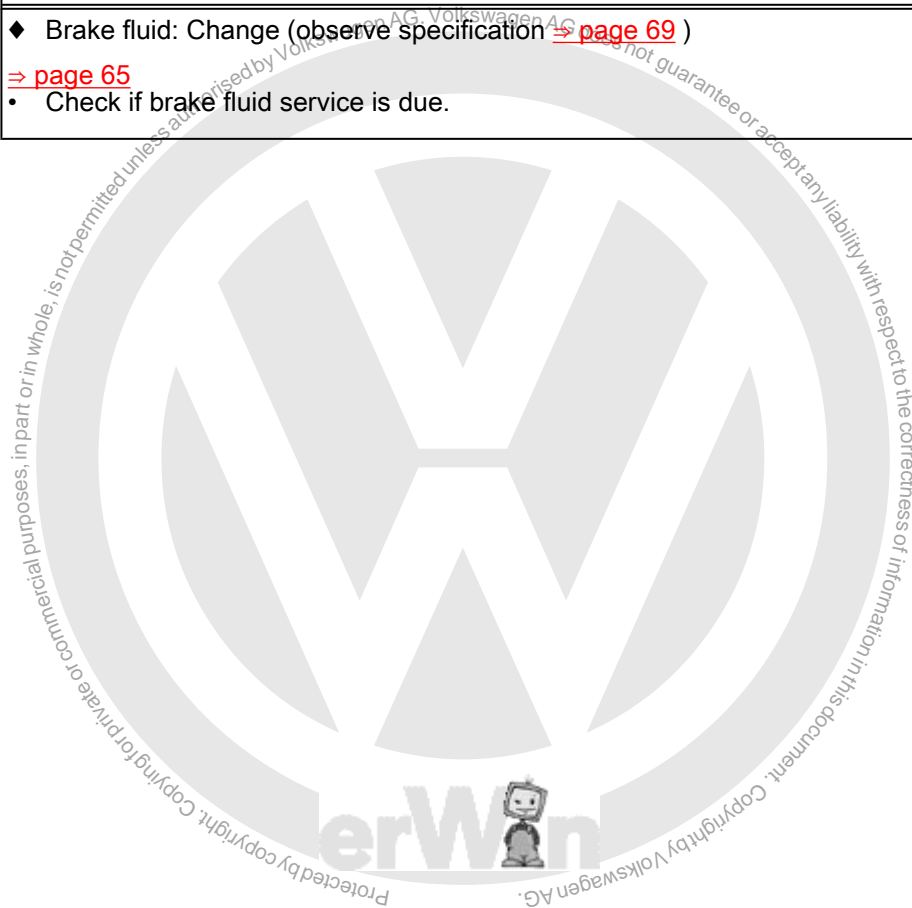



3 General

- ◆ Sticker ⇒ [page 20](#)
- ◆ Entries in service schedule ⇒ [page 22](#)
- ◆ Severe conditions ⇒ [page 20](#)
- ◆ Vehicle identification number (chassis number) ⇒ [page 19](#)
- ◆ Vehicle data sticker ⇒ [page 19](#)
- ◆ Engine code and engine number ⇒ [page 20](#)
- ◆ RME fuel (biodiesel) ⇒ [page 22](#)

3.1 Vehicle identification number (chassis number)

A vehicle identification number is located behind the windscreen on the driver side.

Second vehicle identification number is located on right side of longitudinal member and can be seen in right wheel housing -arrow-.

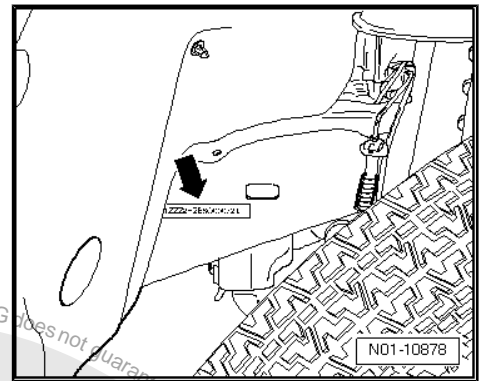

Significance of vehicle identification number

WV1	ZZZ	2H	Z	B	D	000 234
Manufacturer code	Filler characters	Type	Filler characters	Model year 2011	Production location	Serial number

3.2 Vehicle data sticker

The vehicle data sticker -arrow- is attached to the left A-pillar lower trim panel in the footwell.

This vehicle data sticker is also found in the service schedule for the customer.

On the left side of left-hand drives, on the right side of right-hand drives.

Attach second „vehicle data sticker“ in customer service schedule ⇒ [page 21](#)

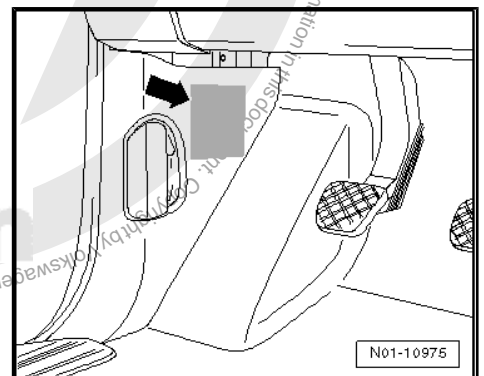



- Enter next service due: Enter a cross according to „service interval display“ and enter date and odometer reading.

- Apply service sticker on driver side door pillar (B-pillar).

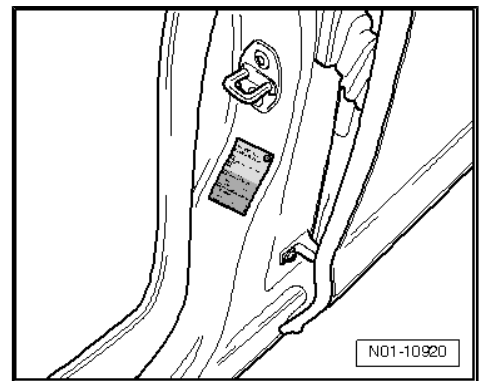

3.5.2 Attaching „vehicle data sticker“ into customer service schedule and in vehicle

Perform the following jobs:

- Attach upper vehicle data sticker -arrow- in customer service schedule.

Installation position of vehicle data sticker => [page 19](#)

- 1 - Week of production
- 2 - Production control number (PR number)

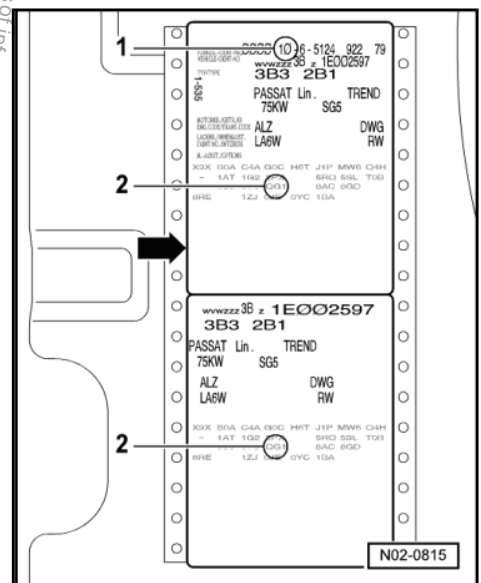

Protected by copyright. Copying for private or commercial purposes, in part or in whole, is not permitted unless authorised by Volkswagen AG. Volkswagen AG does not guarantee or accept any liability with respect to the correctness of information in this document. Copyright by Volkswagen AG.



3.6 Entries in service schedule

- ◆ If a component such as the toothed belt is replaced and is subject to a replacement interval stipulated by the manufacturer,
- ◆ the time period for the new replacement interval starts when the replacement is carried out.
- ◆ Therefore it is very important, every time a component is changed, to document this in the service schedule. This also applies to components which were changed before the regular change interval.
- ◆ There are more entries to be made in the service schedule ⇒ [page 128](#) .



Note

- ◆ *When using genuine parts kits, it must be taken into account whether it is technically necessary to change all the components included in the genuine parts kits.*
- ◆ *If more components are renewed than is technically necessary, inform the customer before repair!*

3.7 RME fuel (biodiesel) that does not conform with the standard



Note

- ◆ *RME fuel may only be used in vehicles which have been approved by Volkswagen for this purpose with RME fuel - either in the standard version or in vehicles with optional equipment (PR number »2G0«).*
- ◆ *The production control number »2G0« on the vehicle data sticker indicates RME compatibility.*
- ◆ *For vehicles with standard diesel particulate filter (DPF) RME fuel (biodiesel) must not be used.*



Caution

- ◆ *When using RME (biodiesel) according to „DIN EN 14214“, the fuel filter must be renewed every 10,000 km.*
- ◆ *When RME fuel is used and your vehicle is not suitable for this, the fuel system can be damaged.*
- ◆ *When filling the tank with biodiesel, only use RME fuel conforming to DIN EN 14214 (FAME)!*
- ◆ *Fuel that does not conform to DIN 14214 can result in fuel filter blocking.*

RME fuel must conform to DIN EN 14214 (FAME).

- ◆ RME means „Rapeseed Methyl Ester“.
- ◆ DIN stands for „Deutsches Institut für Normung e.V. (German Standards Authority)“.
- ◆ EN stands for „European Norm (European standard)“.
- ◆ FAME means „Fatty Acid Methyl Ester“.



Note

- ◆ *The RME compatibility of the vehicle is indicated by the production control number »2G0« on the vehicle data sticker. If the vehicle is not designed to run on biodiesel, the production control number »2G2« is noted in the vehicle data set*
- ◆ *and the message „Not for biodiesel“ is shown inside the fuel filler cap.*

Characteristics of RME fuel

- ◆ Performance can slightly be lower when using biodiesel.
- ◆ Fuel consumption can slightly be higher when using biodiesel.
- ◆ RME can be used in winter at temperatures to approx. -10 °C.
- ◆ At ambient temperatures below -10 °C, the use of winter diesel fuel is recommended.



Note

- ◆ *If standstill times of more than approx. 2 weeks are envisaged, it is recommended that the petrol tank be first filled up with conventional diesel fuel*
- ◆ *and that the vehicle be driven a distance of approx. 50 km in order to prevent damage to the injection system.*





4 Descriptions of work

- ◆ Swivel joints: Visual check ⇒ [page 44](#)
- ◆ Four-wheel drive: Insert fuse ⇒ [page 77](#)
- ◆ Lifting vehicle ⇒ [page 25](#)
- ◆ Reading ash mass (saturation level) of diesel particulate filter ⇒ [page 45](#)
- ◆ Battery: Check battery terminal clamps for secure seating ⇒ [page 47](#) .
- ◆ Battery: Check magic eye ⇒ [page 51](#)
- ◆ Battery: Perform visual check ⇒ [page 51](#)
- ◆ Removing relay for battery disconnection ⇒ [page 51](#)
- ◆ Front passenger front airbag: Check key switch and „On/Off function“ ⇒ [page 55](#) .
- ◆ Checking tyres: Condition, wear pattern, tyre pressure, tread depth ⇒ [page 56](#)
- ◆ Brake system: Perform visual check for leaks and damage ⇒ [page 60](#)
- ◆ Brake fluid level: Check ⇒ [page 69](#)
- ◆ Brake fluid: Change ⇒ [page 65](#)
- ◆ Climatronic: Set temperature to 22 °C ⇒ [page 70](#)
- ◆ Connecting vehicle diagnosis tester ⇒ [page 71](#)
- ◆ Window regulators: Check positioning (open and close functions) ⇒ [page 71](#)
- ◆ Performing vehicle system test ⇒ [page 74](#)
- ◆ Bonnet catch: Clean, ensure attachment is secure and lubricate ⇒ [page 96](#)
- ◆ Protective bellows: Visual check ⇒ [page 80](#)
- ◆ Poly V-belt: Check condition ⇒ [page 81](#)
- ◆ Control unit in dash panel insert -J285- in dash panel insert -K- at 5,000 km, 7,500 km or 10,000 km ⇒ [page 112](#) : Code
- ◆ Fuel system: Bleed (diesel engine) ⇒ [page 83](#)
- ◆ Fuel filter: Drain water (diesel engine) ⇒ [page 84](#)
- ◆ Fuel filter: Renew (diesel engine) ⇒ [page 82](#)
- ◆ Cooling system: Check frost protection and coolant level ⇒ [page 84](#)
- ◆ Paint: Perform visual check for damage and corrosion, interior and exterior when doors and bonnet/rear lid/flaps are open ⇒ [page 128](#)
- ◆ Steering: Check bellows/boots for leaks and damage ⇒ [page 133](#)
- ◆ Air filter: Clean housing and renew filter element ⇒ [page 88](#)
- ◆ Air filter with saturation indicator: Check saturation indicator ⇒ [page 90](#)
- ◆ Engine and components in engine compartment (from above and below): Perform visual check for leaks and damage ⇒ [page 95](#)





- ◆ Engine oil: Drain or extract; renew oil filter and replenish engine oil ⇒ [page 91](#)
- ◆ Oil level: Check ⇒ [page 91](#)
- ◆ Check breakdown set ⇒ [page 96](#) .
- ◆ Performing road test ⇒ [page 97](#) .
- ◆ Wheel securing bolts: Tighten to specified torque ⇒ [page 98](#)
- ◆ Reading radio code (only valid for vehicles without sticker with serial number and radio code on vehicle data sticker) ⇒ [page 99](#)
- ◆ Radio / radio navigation system: Enter anti-theft coding PIN ⇒ [page 101](#) .
- ◆ Radio navigation system: Insert navigation CD/DVD and perform update ⇒ [page 102](#)
- ◆ Front and rear brake pads/linings: Check thickness ⇒ [page 61](#)
- ◆ Windscreen wash/wipe system and headlight washer system: Check function and settings ⇒ [page 102](#)
- ◆ Windscreen wiper blades: Check park position ⇒ [page 105](#) .
- ◆ Headlight adjustment: Check, if necessary adjust ⇒ [page 106](#)
- ◆ Service interval display: Reset ⇒ [page 109](#)
- ◆ Service interval display: Recode (adapt) ⇒ [page 111](#)
- ◆ Power assisted steering: Check fluid level ⇒ [page 126](#)
- ◆ Track rod ends: Check clearance, security and boots ⇒ [page 126](#)
- ◆ Dust and pollen filter: Clean housing and renew filter element ⇒ [page 80](#)
- ◆ Clock: Set to correct time ⇒ [page 129](#)
- ◆ Underbody protection: Perform visual check for damage ⇒ [page 129](#)
- ◆ Removing and installing skid plate ⇒ [page 133](#)
- ◆ Front doors: Grease door arrester ⇒ [page 128](#)
- ◆ Camshaft drive toothed belt: Check condition ⇒ [page 130](#)
- ◆ Camshaft drive toothed belt: Renew ⇒ [page 130](#)
- ◆ Spark plugs: Renew ⇒ [page 131](#)

4.1 Lifting vehicle

- ◆ Raising vehicle with wheel lifts as main support ⇒ [page 26](#)
- ◆ Raising vehicle under rear axle tube ⇒ [page 29](#)
- ◆ Raising vehicle before rear axle tube ⇒ [page 33](#)
- ◆ Alternative lift for front of vehicle ⇒ [page 36](#)
- ◆ Alternative lift for rear of vehicle ⇒ [page 39](#)
- ◆ Additional support of vehicle ⇒ [page 42](#)



4.1.1 Raising vehicle with wheel lifts as main support



WARNING

- ◆ *Before driving onto a lifting platform, ensure that there is sufficient clearance between low-lying vehicle components and lifting platform.*
- ◆ *Before driving a vehicle onto a lifting platform it must be ensured that the vehicle weight does not exceed the permissible lifting capacity of the platform.*
- ◆ *Vehicle may be lifted only at points indicated in figure to avoid damaging vehicle underbody or tipping vehicle.*
- ◆ *Never start engine when vehicle is raised and do not engage a gear in gearbox even if only one driven wheel is touching floor. Disregarding these warnings risks the danger of an accident!*
- ◆ *Any fitter who raises a vehicle on a lifting platform must check the lifting points and that the vehicle is standing securely prior to raising the vehicle, with regard to the loading condition and the work to be performed.*
- ◆ *Laden vehicles are only allowed to be raised using wheel lifts as main support. If wheels need to be removed, then laden vehicles are also allowed to be raised under rear axle tube using prismatic supports ⇒ [page 33](#) . If this is not possible because work is to be performed on rear axle then vehicle must be unloaded.*
- ◆ *If vehicle is jacked up with a workshop jack in order to work underneath then it must be securely supported using suitable stands.*



Note

- ◆ *Raising vehicle with wheel lifts should mainly be done for all assembly work on vehicle.*
- ◆ *Only use support points listed in document when assembly work is performed on running gear or on axles.*
- ◆ *Vehicle must under no circumstances be raised on sills, otherwise its body will be seriously damaged.*

Perform the following jobs:

- Reconfigure lifting platform so that existing 4 mounting plates are replaced by 4 wheel lift supports -1-
- Adjust distances of lifting platform in relation to one another so that all 4 wheels fit precisely into wheel lifts -2-
- Drive vehicle onto lifting platform until vehicle is located exactly in wheel lifts.

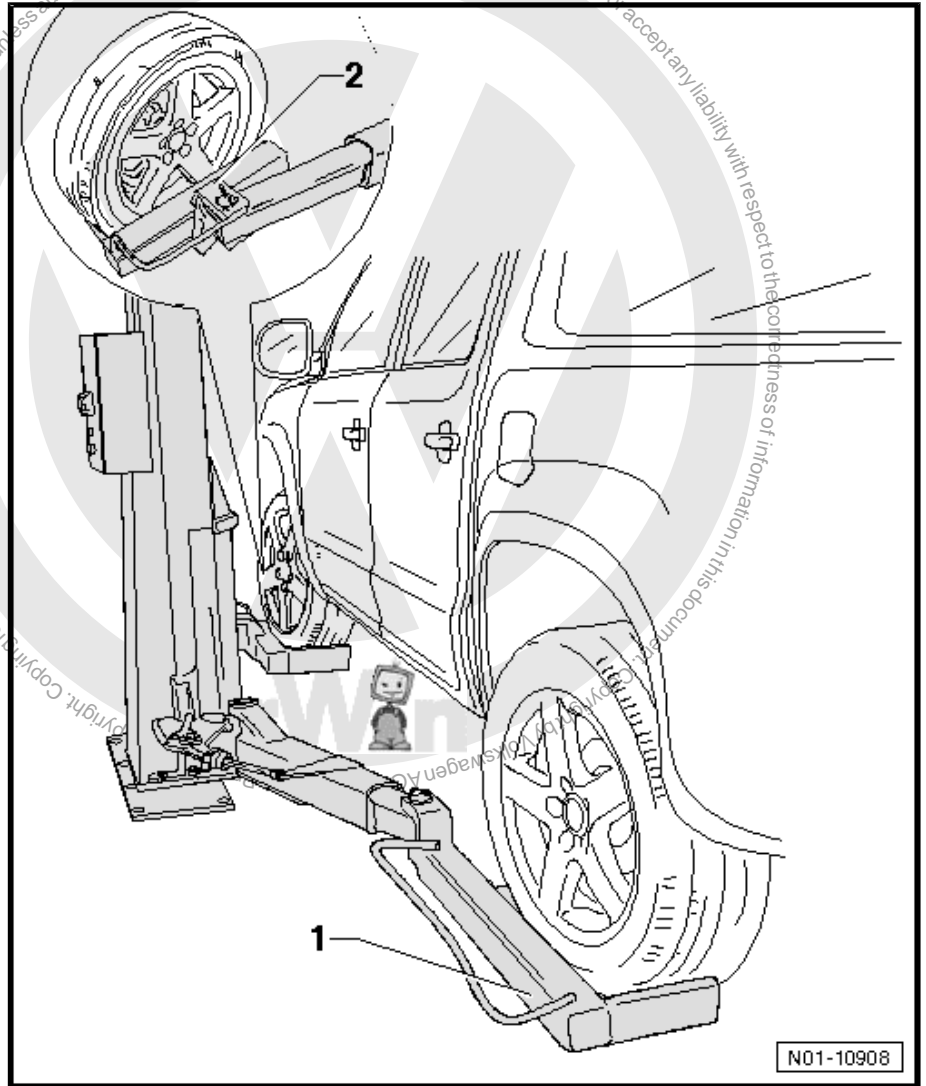

- Vehicle can now be raised and lowered to required working height.

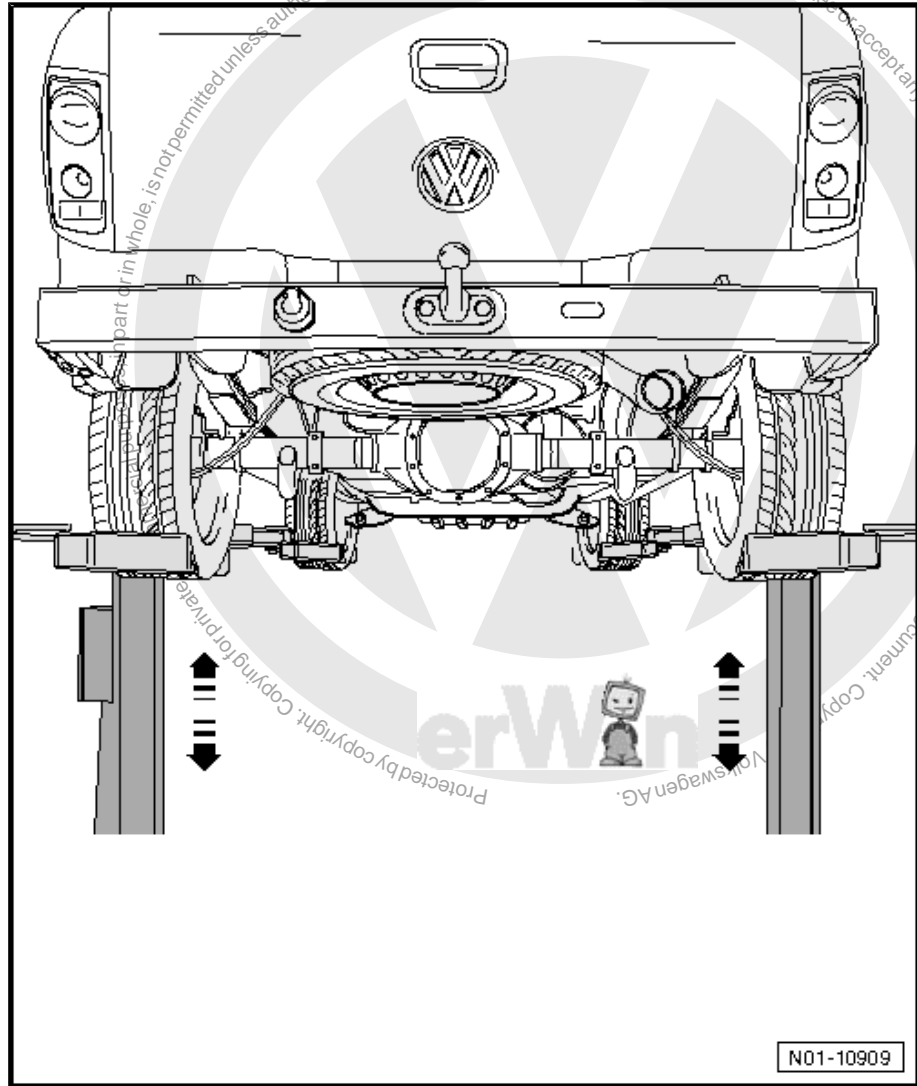



4.1.2 Raising vehicle under rear axle tube



WARNING

- ◆ *Before driving onto a lifting platform, ensure that there is sufficient clearance between low-lying vehicle components and lifting platform.*
- ◆ *Before driving a vehicle onto a lifting platform it must be ensured that the vehicle weight does not exceed the permissible lifting capacity of the platform.*
- ◆ *Vehicle may be lifted only at points indicated in figure to avoid damaging vehicle underbody or tipping vehicle.*
- ◆ *Never start engine when vehicle is raised and do not engage a gear in gearbox even if only one driven wheel is touching floor. Disregarding these warnings risks the danger of an accident!*
- ◆ *Any fitter who raises a vehicle on a lifting platform must check the lifting points and that the vehicle is standing securely prior to raising the vehicle, with regard to the loading condition and the work to be performed.*
- ◆ *Laden vehicles are only allowed to be raised using wheel lifts as main support ⇒ [page 26](#) . If wheels need to be removed, then laden vehicles are also allowed to be raised under rear axle tube using prismatic supports ⇒ [page 29](#) . If this is not possible because work is to be performed on rear axle then vehicle must be unloaded.*
- ◆ *If vehicle is jacked up with a workshop jack in order to work underneath then it must be securely supported using suitable stands.*

Special tools and workshop equipment required

- ◆ Tensioning strap -T10038-

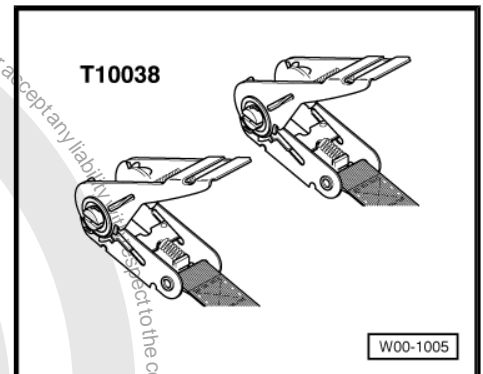

- ◆ Prismatic support with minimum opening angle 120°. Note that the versions differ from one lifting platform manufacturer to another.

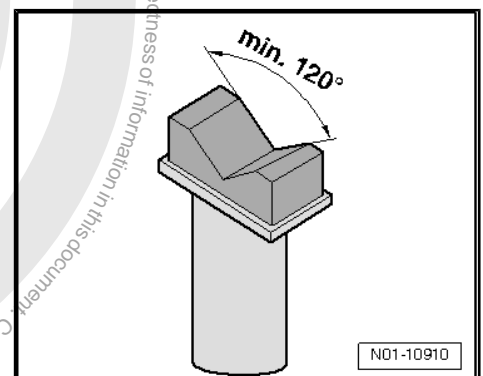



Note

- ◆ *When assembly work is performed on running gear (front axle and rear axle) then raising vehicle under rear axle should only be used as an alternative to main support ⇒ [page 26](#) !*
- ◆ *The vehicle may only be lifted at points indicated in order to avoid damaging vehicle and to prevent vehicle from tipping.*
- ◆ *Vehicle must always be lashed down additionally during all assembly work.*
- ◆ *Vehicle must under no circumstances be raised on sills, otherwise its body will be seriously damaged.*

Perform the following jobs:

- Position rear support arms of lifting platform with prismatic supports -1- as shown in illustration, exactly under rear axle tube.
- Position front support arms of lifting platform with rubber plate supports under front frame screw connection -2- and -3-.
- Additionally secure vehicles with tensioning straps -T10038- -4- directly on frame of front and rear support arms of lifting platform.



Note

To avoid damage, make sure that no electrical cables, brake lines or fuel lines become trapped.



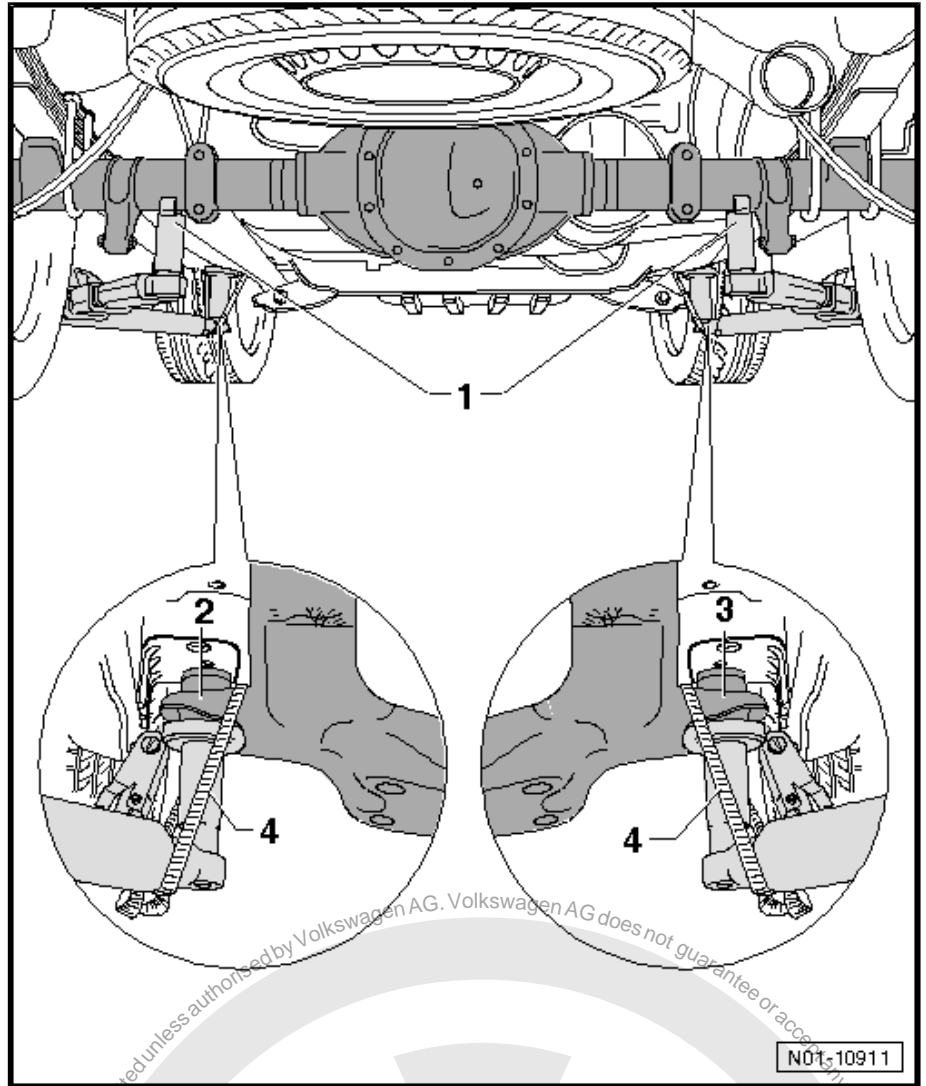

- Vehicle can now be raised and lowered to required working height.

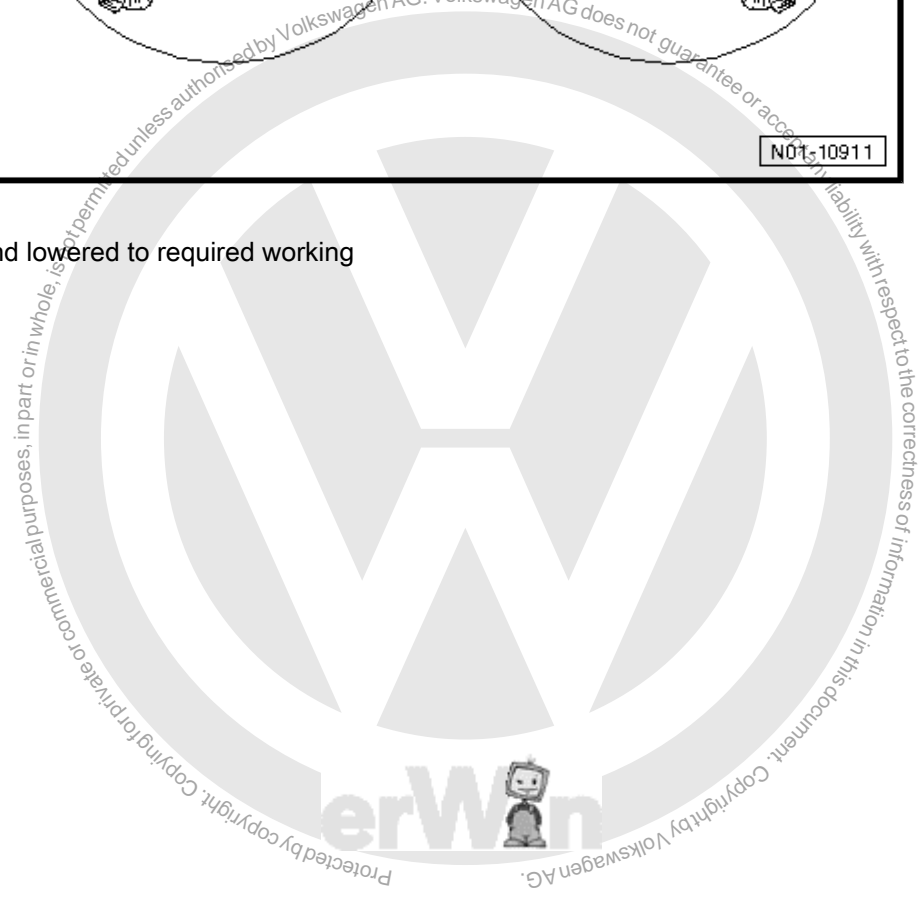

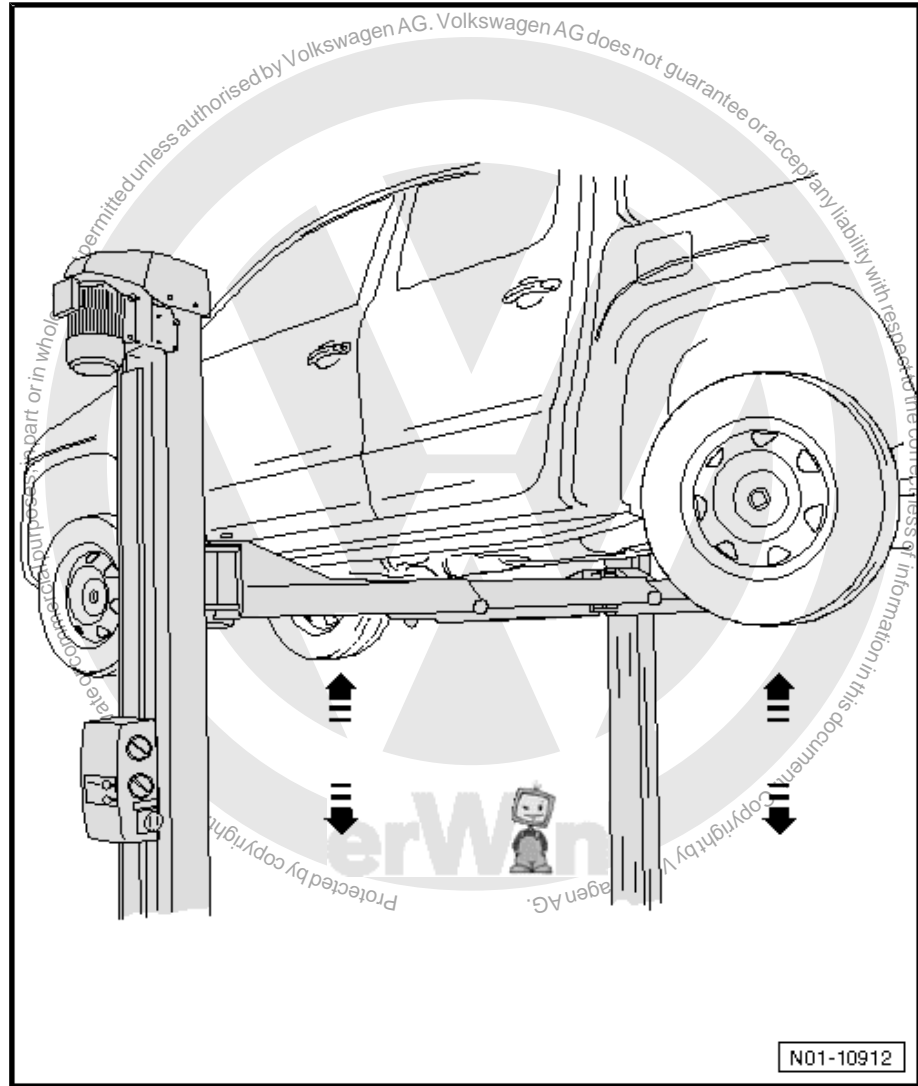



4.1.3 Raising vehicle before rear axle tube



WARNING

- ◆ *Before driving onto a lifting platform, ensure that there is sufficient clearance between low-lying vehicle components and lifting platform.*
- ◆ *Before driving a vehicle onto a lifting platform it must be ensured that the vehicle weight does not exceed the permissible lifting capacity of the platform.*
- ◆ *Vehicle may be lifted only at points indicated in figure to avoid damaging vehicle underbody or tipping vehicle.*
- ◆ *Never start engine when vehicle is raised and do not engage a gear in gearbox even if only one driven wheel is touching floor. Disregarding these warnings risks the danger of an accident!*
- ◆ *Any fitter who raises a vehicle on a lifting platform must check the lifting points and that the vehicle is standing securely prior to raising the vehicle, with regard to the loading condition and the work to be performed.*
- ◆ *Laden vehicles are only allowed to be raised using wheel lifts as main support ⇒ [page 26](#). If wheels need to be removed, then laden vehicles are also allowed to be raised under rear axle tube using prismatic supports ⇒ [page 29](#). If this is not possible because work is to be performed on rear axle then vehicle must be unloaded.*
- ◆ *If vehicle is jacked up with a workshop jack in order to work underneath then it must be securely supported using suitable stands.*

Special tools and workshop equipment required

- ◆ Tensioning strap -T10038-

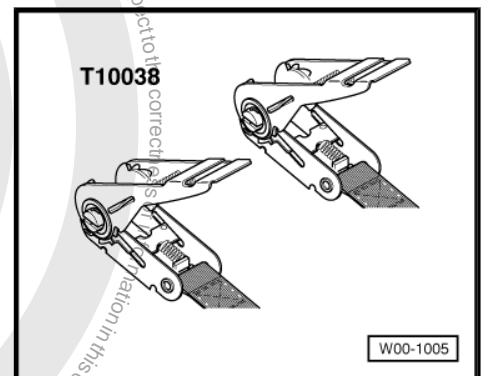

Note

- ◆ *For assembly work on vehicle, e.g. removal of front axle and rear axle, vehicle can be raised before rear axle tube as an alternative ⇒ [page 33](#).*
- ◆ *The vehicle may only be lifted at points indicated in order to avoid damaging vehicle and to prevent vehicle from tipping.*
- ◆ *Vehicle must always be lashed down additionally during all assembly work.*
- ◆ *Laden vehicles must be unloaded before being raised.*
- ◆ *Vehicle must under no circumstances be raised on sills or front leaf spring supports, otherwise it will slip off and its body could be seriously damaged.*



Perform the following jobs:

- Front support arms of lifting platform with rubber plate supports are positioned in area of front bolted gearbox cross member.
- Rear support arms of lifting platform with rubber plate supports -1- are positioned in front of front leaf spring supports -2- under vehicle frame.
- Additionally secure vehicles with tensioning straps -T10038- -4- directly on frame of front and rear support arms of lifting platform.



Note

To avoid damage, make sure that no electrical cables, brake lines or fuel lines become trapped.

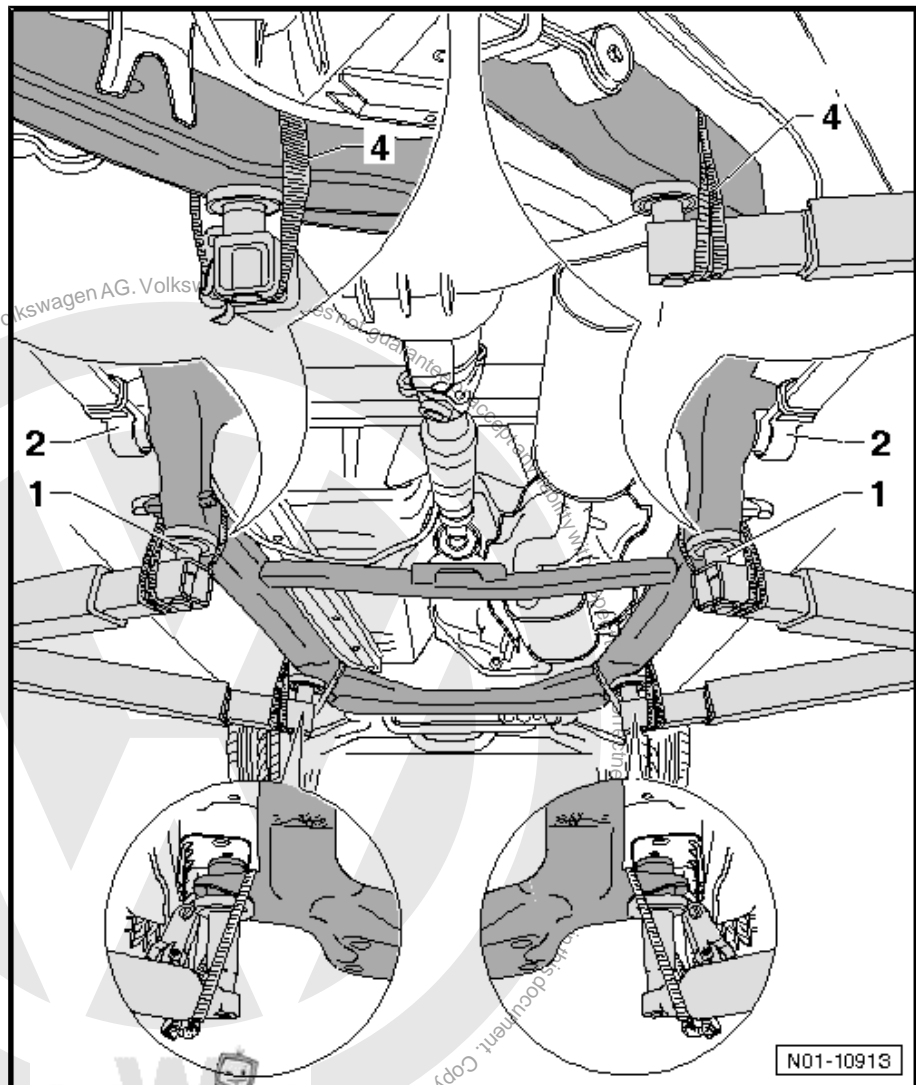

- Vehicle can now be raised and lowered to required working height.

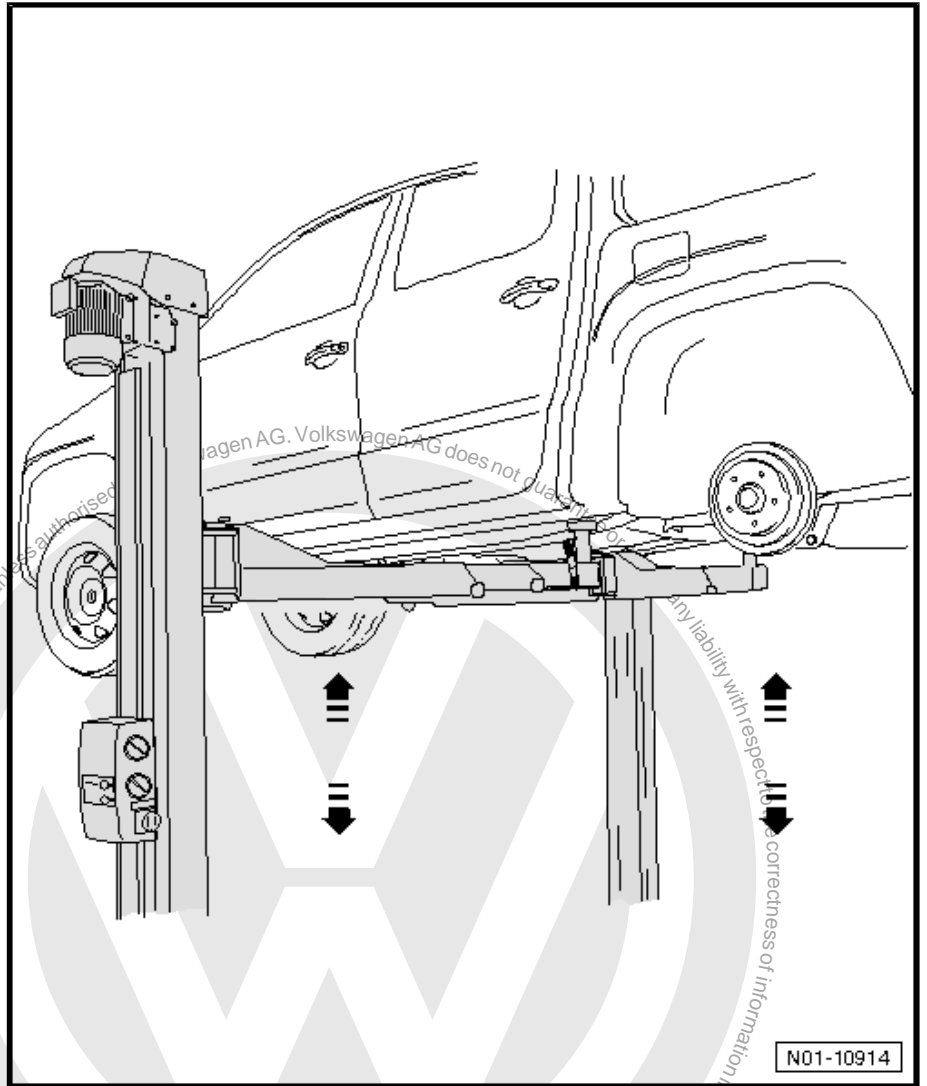

Protected by copyright. Copying for private or commercial purposes, in part or in whole, is not permitted unless authorised by Volkswagen AG. Volkswagen AG does not accept any liability with respect to the correctness of information in this document. Copyright by Volkswagen AG.



4.1.4 Alternative lift for front of vehicle



WARNING

- ◆ Before driving onto a lifting platform, ensure that there is sufficient clearance between low-lying vehicle components and lifting platform.
- ◆ Before driving a vehicle onto a lifting platform it must be ensured that the vehicle weight does not exceed the permissible lifting capacity of the platform.
- ◆ Vehicle may be lifted only at points indicated in figure to avoid damaging vehicle underbody or tipping vehicle.
- ◆ Never start engine when vehicle is raised and do not engage a gear in gearbox even if only one driven wheel is touching floor. Disregarding these warnings risks the danger of an accident!
- ◆ Any fitter who raises a vehicle on a lifting platform must check the lifting points and that the vehicle is standing securely prior to raising the vehicle, with regard to the loading condition and the work to be performed.
- ◆ Laden vehicles are only allowed to be raised using wheel lifts as main support ⇒ [page 26](#) . If wheels need to be removed, then laden vehicles are also allowed to be raised under rear axle tube using prismatic supports ⇒ [page 29](#) . If this is not possible because work is to be performed on rear axle then vehicle must be unloaded.
- ◆ If vehicle is jacked up with a workshop jack in order to work underneath then it must be securely supported using suitable stands.

Special tools and workshop equipment required

- ◆ Tensioning strap -T10038-

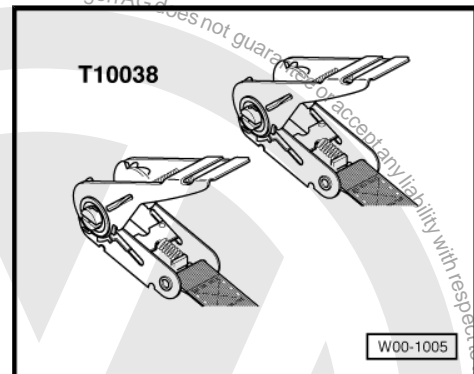

Note

- ◆ For assembly work on vehicle, e.g. removal of front axle and rear axle, vehicle can be raised before rear axle tube as an alternative ⇒ [page 33](#) .
- ◆ The vehicle may only be lifted at points indicated in order to avoid damaging vehicle and to prevent vehicle from tipping.
- ◆ Vehicle must always be lashed down additionally during all assembly work.
- ◆ Laden vehicles must be unloaded before being raised.
- ◆ Vehicle must under no circumstances be raised on sills or front leaf spring supports, otherwise it will slip off and its body could be seriously damaged.



Perform the following jobs:

- Front support arms -1- of lifting platform with rubber plate supports are positioned in area of front bolted gearbox cross member.
- Additionally secure vehicles with tensioning straps -T10038-2- directly on frame of front and rear support arms of lifting platform.



Note

To avoid damage, make sure that no electrical cables, brake lines or fuel lines become trapped.

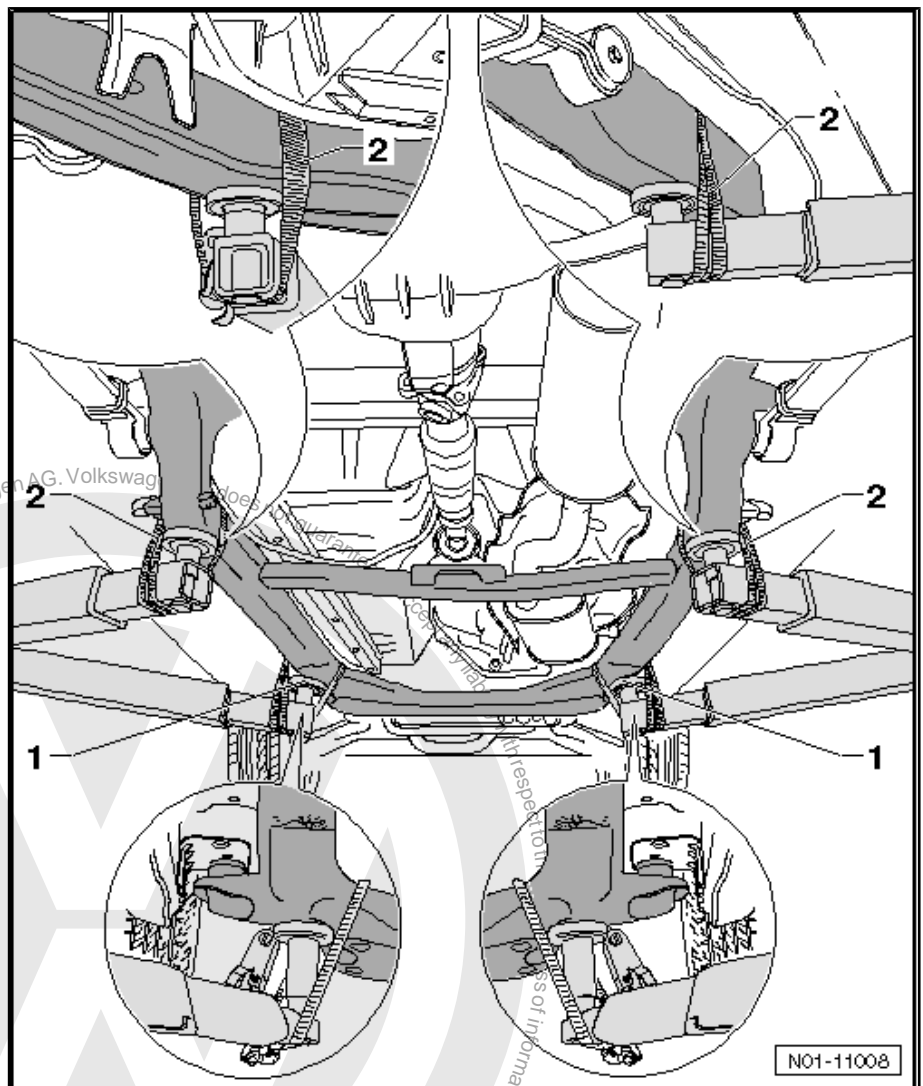

- Vehicle can now be raised and lowered to required working height.

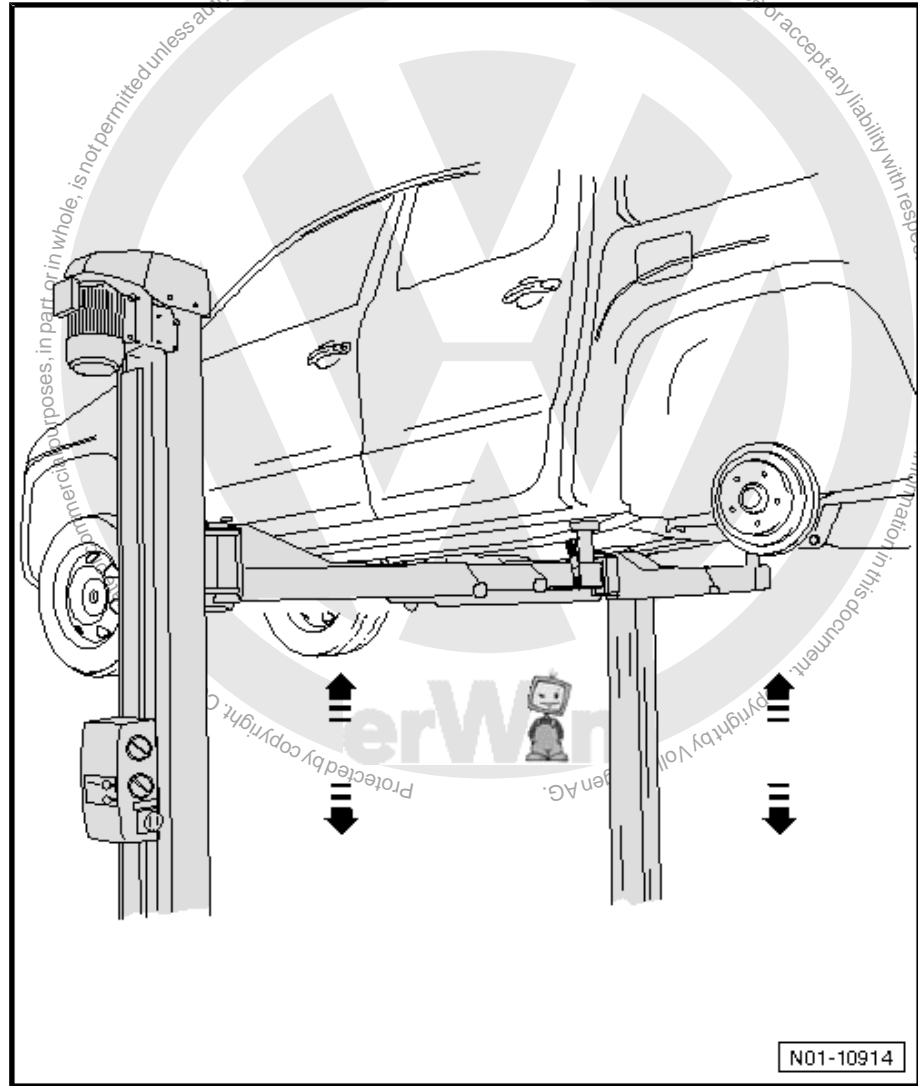



4.1.5 Alternative lift for rear of vehicle



WARNING

- ◆ *Before driving onto a lifting platform, ensure that there is sufficient clearance between low-lying vehicle components and lifting platform.*
- ◆ *Before driving a vehicle onto a lifting platform it must be ensured that the vehicle weight does not exceed the permissible lifting capacity of the platform.*
- ◆ *Vehicle may be lifted only at points indicated in figure to avoid damaging vehicle underbody or tipping vehicle.*
- ◆ *Never start engine when vehicle is raised and do not engage a gear in gearbox even if only one driven wheel is touching floor. Disregarding these warnings risks the danger of an accident!*
- ◆ *Any fitter who raises a vehicle on a lifting platform must check the lifting points and that the vehicle is standing securely prior to raising the vehicle, with regard to the loading condition and the work to be performed.*
- ◆ *Laden vehicles are only allowed to be raised using wheel lifts as main support ⇒ [page 26](#) . If wheels need to be removed, then laden vehicles are also allowed to be raised under rear axle tube using prismatic supports ⇒ [page 29](#) . If this is not possible because work is to be performed on rear axle then vehicle must be unloaded.*
- ◆ *If vehicle is jacked up with a workshop jack in order to work underneath then it must be securely supported using suitable stands.*

Special tools and workshop equipment required

- ◆ Tensioning strap -T10038-

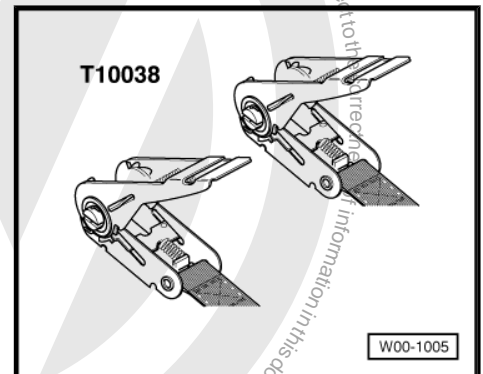

- ◆ Anti-slip discs -V.A.G 1994-



Note

- ◆ For assembly work on vehicle, e.g. removal of front axle and rear axle, vehicle can be raised before rear axle tube as an alternative ⇒ [page 33](#).
- ◆ The vehicle may only be lifted at points indicated in order to avoid damaging vehicle and to prevent vehicle from tipping.
- ◆ Vehicle must always be lashed down additionally during all assembly work.
- ◆ Laden vehicles must be unloaded before being raised.
- ◆ Vehicle must under no circumstances be raised on sills or front leaf spring supports, otherwise it will slip off and its body could be seriously damaged.

Perform the following jobs:

- Front support arms of lifting platform with rubber plate supports are positioned in area of front bolted gearbox cross member.
- The rear support arms of the lifting platform with anti-slip discs -V.A.G 1994- -1- are positioned in front of the front leaf spring support -2- under the vehicle frame.
- Additionally secure vehicles with tensioning straps -T10038- -3- directly on frame of front and rear support arms of lifting platform.



Note

To avoid damage, make sure that no electrical cables, brake lines or fuel lines become trapped.

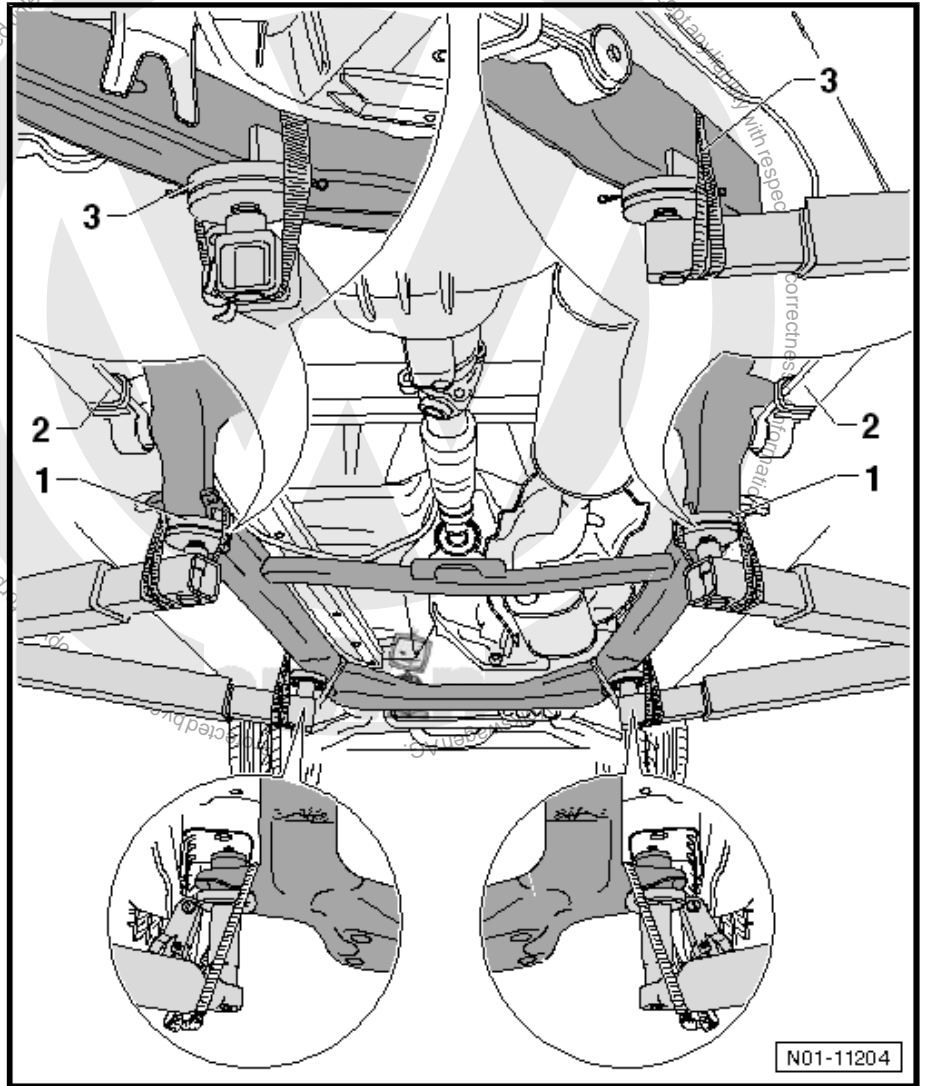

- Vehicle can now be raised and lowered to required working height.

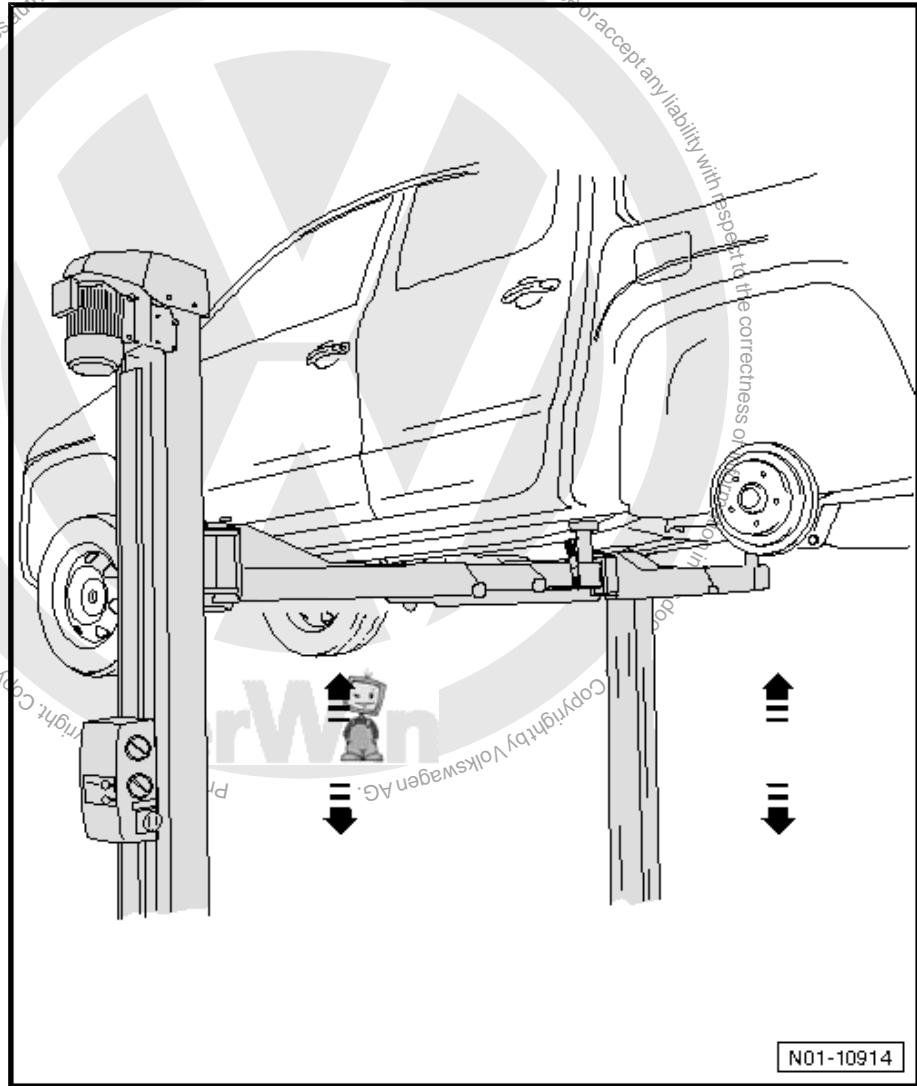

4.1.6 Additional support of vehicle



Note

- ◆ Depending on assembly condition of vehicle, it can be secured using height-adjustable stands -2- in addition to lashing it to support arms of lifting platform with tensioning straps - T10038-.
- ◆ To avoid damage, make sure that no electrical cables, brake lines or fuel lines become trapped.

Perform the following jobs:

- Place height-adjustable stands -1- for supporting vehicle under rear longitudinal member -arrows-.

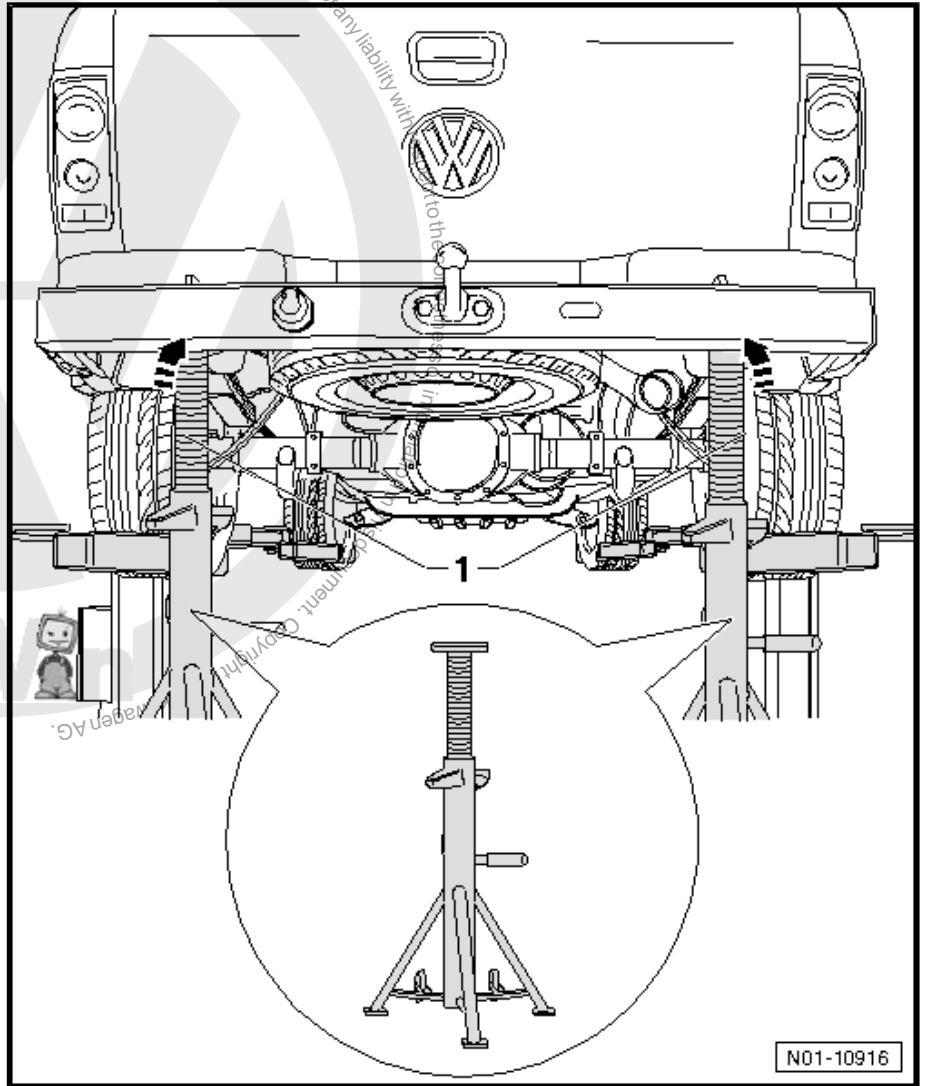

- Alternatively, height-adjustable stands -2- can be positioned under rear leaf spring bracket -1- on rear axle tube.

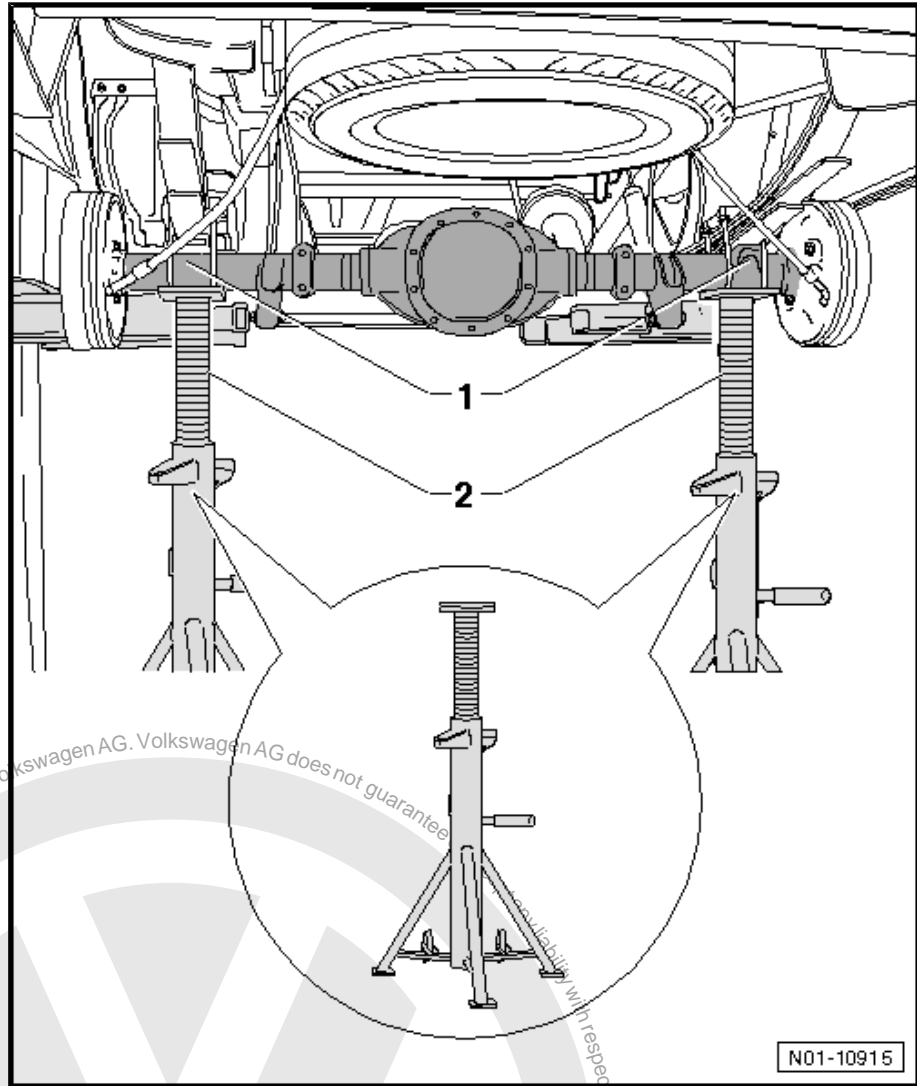

4.2 Swivel joints: Visual check

Perform the following jobs:

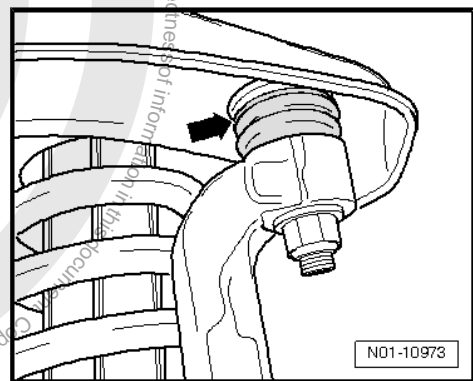



- Check boots -arrow- of lower swivel joints for leaks and damage.

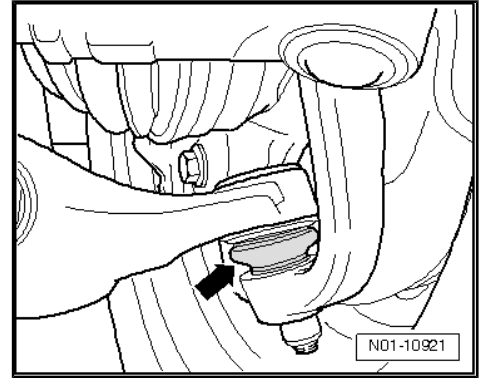

- Check boots -arrow- of upper swivel joints for leaks and damage.

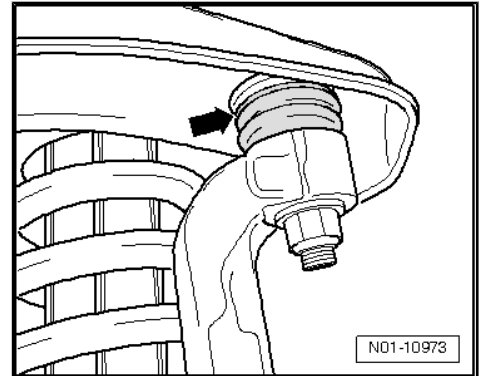

4.3 Reading ash mass (saturation level) of diesel particulate filter



Note

- ◆ *The ash mass test provides information on the saturation level of the particulate filter volume.*
- ◆ *After a certain running time diesel particulate filters must be exchanged, because of ash deposits.*
- ◆ *This running time mainly depends on the filter size, oil and fuel consumption and engine output.*

Special tools and workshop equipment required

- ◆ Vehicle diagnostic, testing and information system -VAS 5051B- or subsequent units

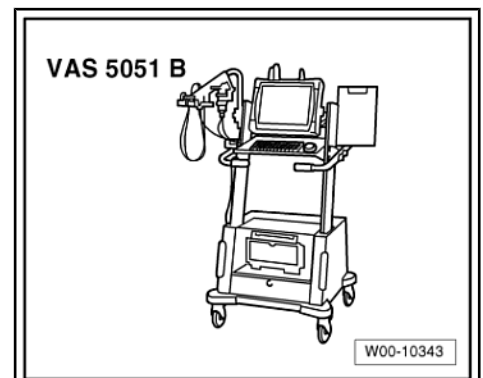

- ◆ Diagnosis cable -VAS 5051/5A-
- Or
- ◆ Diagnosis cable 5m -VAS 5051B/1-
- Or



- ◆ Vehicle diagnostic and service information system -VAS 5052 A-

- ◆ Diagnosis cable, 2 m -VAS 5052/3 A-

Or

- ◆ Diagnosis cable, 5 m -VAS 5052/3 A-1-

Perform the following jobs:

- Pull on handbrake.
- Manual gearbox: Gear lever in neutral
- Connect vehicle diagnostic, testing and information system -VAS 5051B- or vehicle diagnostic and service information system -VAS 5052 A- with ignition switched off ⇒ [page 71](#) .
- Press the Guided functions button -arrow- on display of vehicle diagnostic, testing and information system -VAS 5051B- or vehicle diagnostic and service information system -VAS 5052 A- .

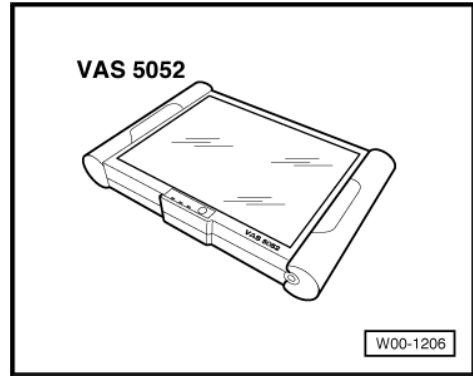

Indicated on display:

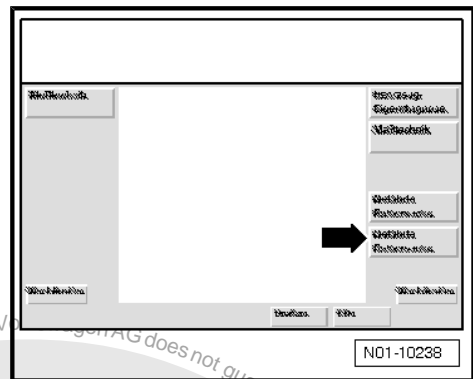

- Select engine on vehicle diagnostic, testing and information system -VAS 5051B- or vehicle diagnostic and service information system -VAS 5052 A- -arrow-.

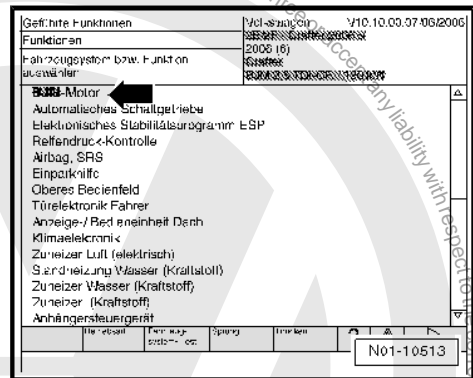

- Press Read motor control unit J623- -arrow-.

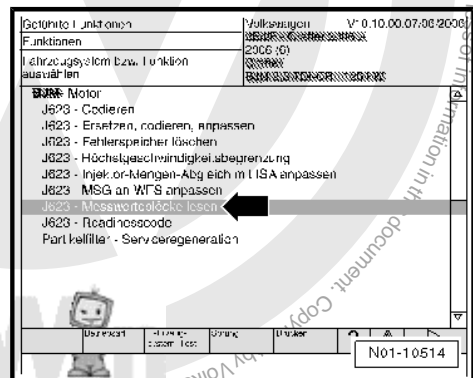



– Select „Measured value block 68 - ash mass DPF“ -arrow- on screen and confirm with **Done** button.

– Follow instructions of vehicle diagnostic, testing and information system -VAS 5051B- or vehicle diagnostic and service information system -VAS 5052 A- .

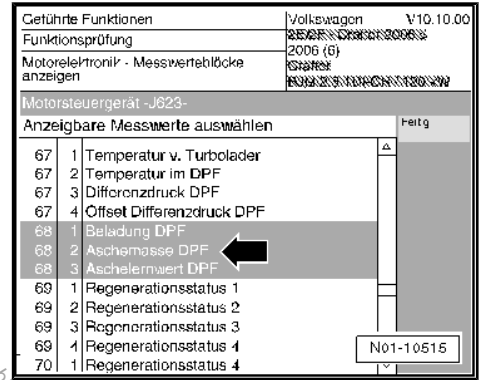

– Press **Read** button -arrow- to display the ash mass measured values.

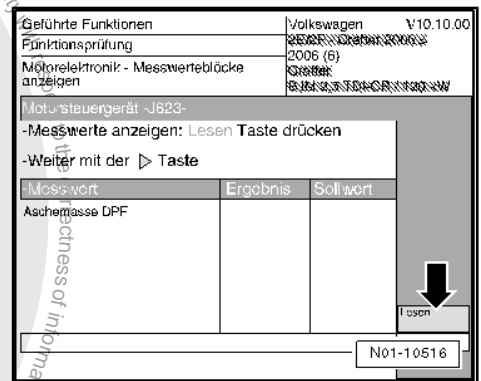

The ash mass is displayed in the result column -arrow-.



Note

- ◆ If the limit value of 95 grams is reached the diesel particulate filter must be renewed ⇒ Rep. gr. 26 .
- ◆ If the indicated ash mass limit value is not reached, the vehicle can be driven further 40,000 km.
- ◆ The ash mass (saturation level) of the diesel particulate filter must be read every 40,000 km.

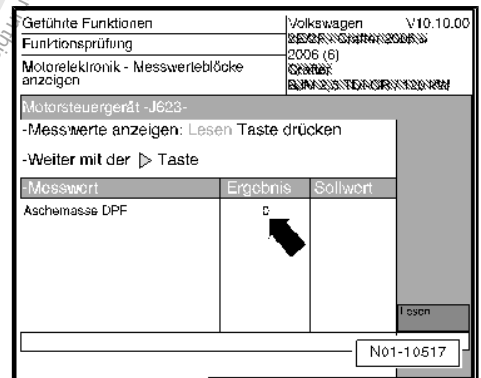

– Follow instructions of vehicle diagnostic, testing and information system -VAS 5051B- or vehicle diagnostic and service information system -VAS 5052 A- and end „Guided functions“ operating mode with **No** button -arrow-.

– Switch off ignition and then disconnect vehicle diagnostic, testing and information system -VAS 5051B- or vehicle diagnostic and service information system -VAS 5052 A- from vehicle.

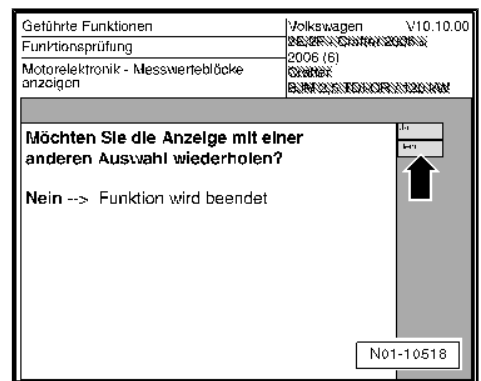

4.4 Battery: Check battery terminal clamps for secure seating

- ◆ Specified torques: Battery ⇒ [page 50](#)
- ◆ Battery: Check battery terminal clamps for secure seating ⇒ [page 48](#) .
- ◆ Battery terminal connections ⇒ [page 50](#)



Note

- ◆ *The battery terminal clamps must only be connected by hand without using force, to ensure the battery housing is not damaged.*
- ◆ *Battery terminals must not be greased.*
- ◆ *Always adhere to the sequence of work steps.*
- ◆ *Disconnecting the battery earth cable ensures safe working on the electrical system.*

Special tools and workshop equipment required

- ◆ Torque wrench -V.A.G 1331/- (5-50 Nm)

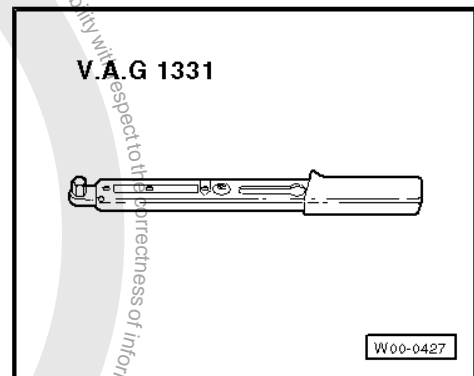

4.4.1 Battery: Check battery terminal clamps for secure seating



Note

- ◆ *In all vehicles a battery with „magic eye“ and covered-over cell sealing plugs or without cell sealing plugs is installed.*
- ◆ *A securely seated battery clamp ensures trouble free function and long service life of the battery.*
- ◆ *The battery is located in engine compartment.*

– Battery installation position ⇒ Electrical system; Rep. gr. 27

Perform the following jobs:

- Switch off ignition, all electrical consumers and withdraw ignition key.



Note

It can be necessary to remove battery positive terminal cover, depending on equipment variant.



- Check whether battery clamps are secure on battery terminals by moving battery negative cable -1- and battery positive cable -2- back and forth.

WARNING

If the battery terminal clamp is not seated securely on the positive terminal, first disconnect battery terminal clamp from battery negative terminal.

If the battery terminal clamp is not seated securely on positive terminal:

Perform the following jobs:

- Disconnect battery terminal clamp -1- from battery negative terminal first.
- Open battery positive terminal cover.
- Tighten battery terminal clamp -2- on battery positive terminal to specified torque => [page 50](#)
- Close battery positive terminal cover.

Reconnect battery terminal clamp -1- on battery negative terminal and tighten to specified torque => [page 50](#) .

If the battery terminal clamp on negative terminal is not seated securely:

Perform the following jobs:

- Tighten battery terminal clamp -1- on battery positive terminal to specified torque => [page 50](#) .

Note

If the battery has been reconnected, observe procedures described in => [Electrical system; Rep. gr. 27](#) .

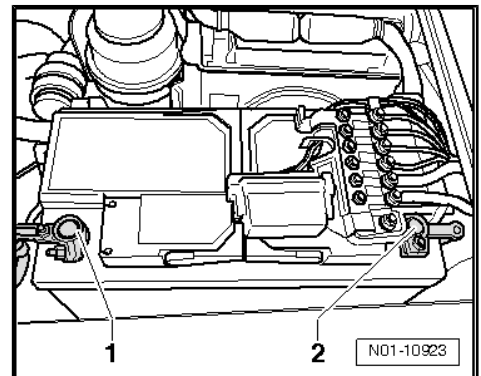
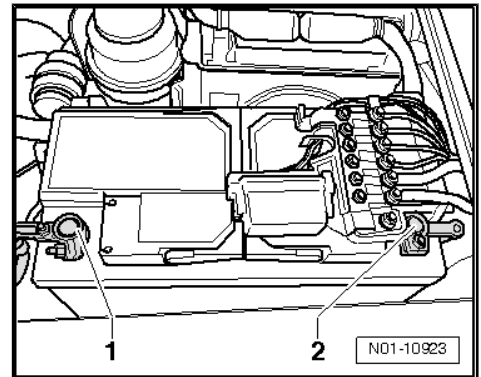
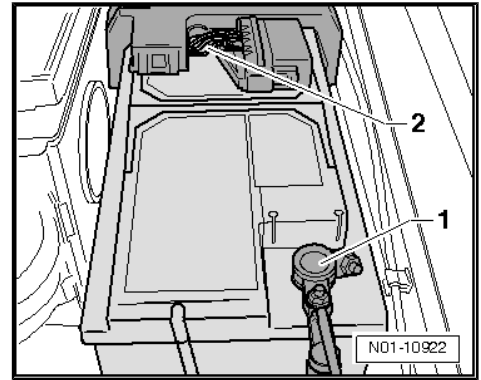



4.4.2 Battery terminal connections



Caution

To prevent damage to the battery terminal clamps and the battery terminals, observe the following:

- ◆ **The battery terminal clamps must only be connected by hand (without using force).**
- ◆ **Battery terminals must not be greased.**
- ◆ **Install battery terminal clamps so that the battery terminal is flush with clamp or it projects through it.**
- ◆ **When connecting the battery, always follow the procedure described in workshop manual => Rep. gr. 27**
- ◆ **After tightening the battery terminal clamps to the prescribed torque, they must not be retightened!**

For specified torques of battery terminal clamps -1- and additional clamps -2-, refer to table „Specified torques: Battery“ => [page 50](#) .

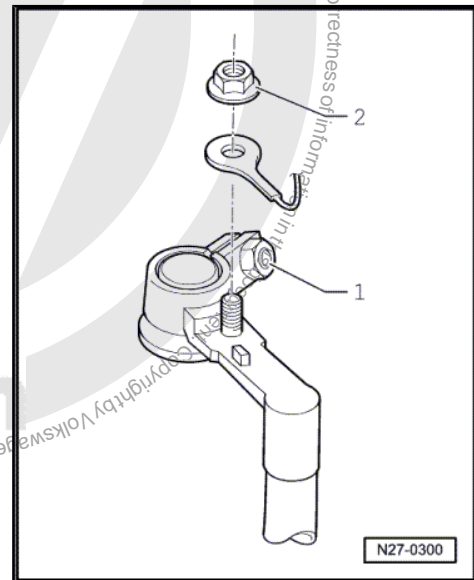

4.4.3 Specified torques: Battery



Caution

- ◆ **After tightening the battery terminal clamps to the prescribed torque, they must not be retightened.**

Follow notes regarding battery terminal connections => [page 50](#) .

Threaded connections	Specified torques
Battery -A-: Battery terminal clamps on battery terminals M6	6 Nm
Battery -A-: Securing bolt for battery carrier M8x35	23 Nm



4.5 Battery: Perform visual check and check magic eye

Perform the following jobs:

- Visual inspection of battery as well as a battery check using „magic eye“
- ◆ Battery: Perform visual check ⇒ Electrical system; Rep. gr. 27
- ◆ Battery: Check magic eye ⇒ Electrical system; Rep. gr. 27

4.6 Removing relay for battery disconnection

On vehicles with transport equipment, a battery cut-off relay is fitted on the battery positive terminal in left engine compartment.

On RHD vehicles an additional adapter cable is installed to extend the wiring harness of the battery cut-off relay to connect the brake fluid reservoir in right engine compartment.

The battery cut-off relay protects the battery from discharging by electrical consumers not required during transportation from manufacturer to dealer.

- ◆ The battery cut-off relay and the adapter cable for RHD vehicles must be removed for delivery inspection, if still fitted.
- ◆ Collect removed battery cut-off relay and, if necessary, adapter cable for RHD, and send back to manufacturer ⇒ [page 54](#) .



Note

- ◆ *The battery terminal clamps must only be connected by hand without using force, to ensure the battery housing is not damaged.*
- ◆ *Battery terminals must not be greased.*
- ◆ *Disconnecting the battery earth cable ensures safe working on the electrical system.*

Special tools and workshop equipment required

- ◆ Torque wrench -V.A.G 1331- (5-50 Nm)

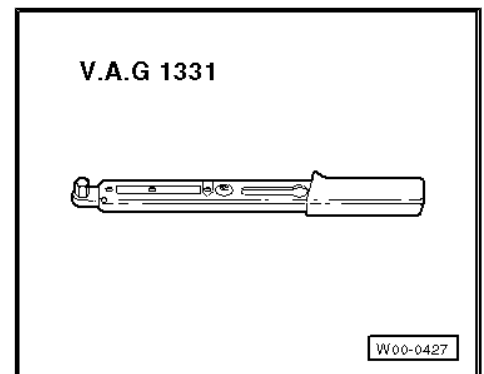

Procedure for all vehicles

Perform the following jobs:

- Switch off ignition and all electrical consumers.



- Disconnect battery terminal clamp -1- on battery negative terminal first.
- Separate connector -1- between vehicle side cable and wiring harness to battery cut-off relay.

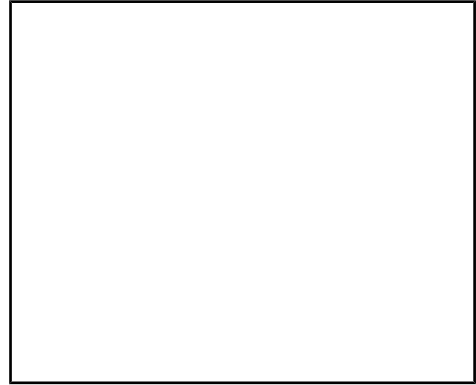

- Separate connector -2- of wiring harness for battery cut-off relay from brake fluid reservoir.



- Secure vehicle side cable -1- back on brake fluid reservoir connection.

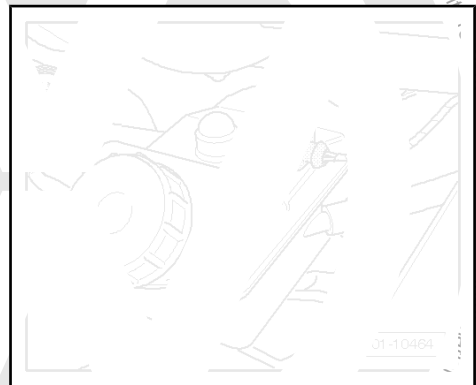

- Unscrew securing bolt (10 mm) -1- of battery cut-off relay from jump start point for battery positive terminal and remove.

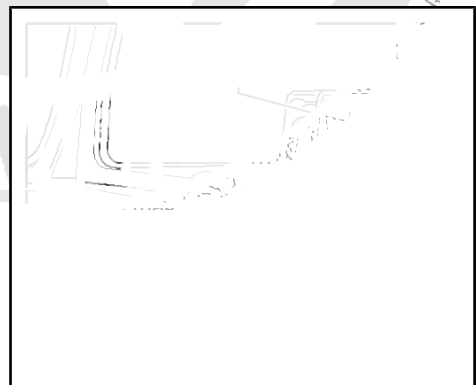



- Loosen hexagon flange nut (10 mm) -1- from battery cut-off relay and remove cable to main fuse box -2- from connection.

Procedure for RHD vehicles

On RHD vehicles an additional adapter cable is installed to extend the wiring harness of the battery cut-off relay to connect the brake fluid reservoir in right engine compartment.

Perform the following jobs:

- Open cable tie -1- on centre of bulkhead and remove wiring harness of battery cut-off relay -2- with adapter cable -3- from cable tie.

- Remove cable tie by unscrewing it from stud.

Procedure for all vehicles

Perform the following jobs:

- Remove battery cut-off relay with wiring harness and, if necessary, adapter cable for RHD.

- Unscrew jump start point (17 mm) -1- from battery positive terminal and remove.
- Route cable to main fuse box -2- to battery positive terminal.
- Place the cable in the envisaged position -arrow- in the terminal protector on the battery positive terminal.
- Now secure cable to main fuse box -2- with jump start point -1- to battery positive terminal.

Specified torque: 8 ± 1 Nm

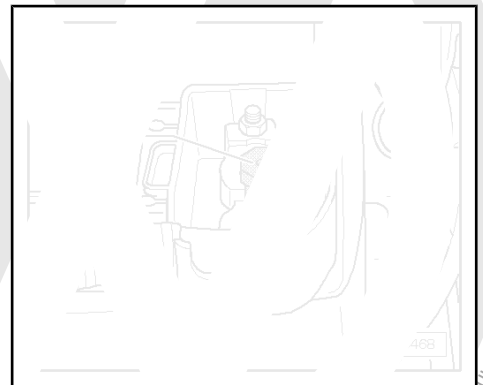
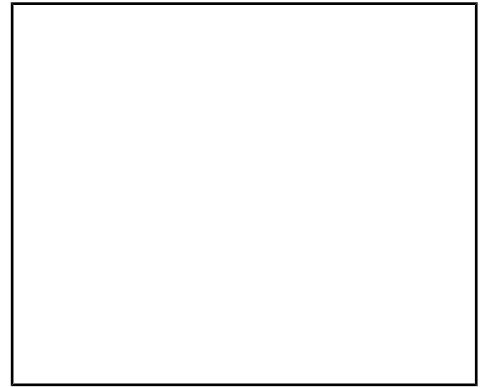



- Remove red terminal cap -1- from ashtray and insert it into thread of jump start point -2-.
- Reconnect battery terminal clamp to battery negative terminal.
- Tighten securing bolt of terminal clamp to specified torque
⇒ [page 50](#) .
- Install battery cover.

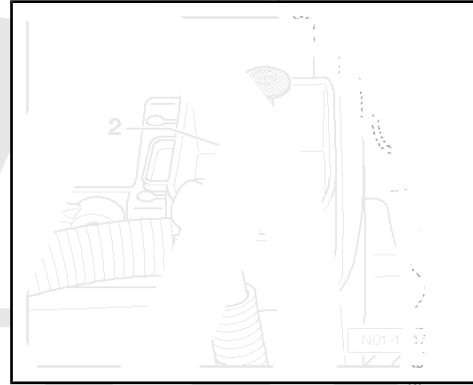

Note

If the battery has been reconnected, observe procedures described in ⇒ [Electrical system; Rep. gr. 27](#) .

4.6.1 Parts dispatch



Note

- ◆ *The battery cut-off relay and/or the RHD adapter cables are so-called rotatable parts and are urgently required for the vehicle production.*
- ◆ *The parts must be packed in a cardboard box in order to prevent damage to the battery cut-off relay and the adapter cable during transport.*
- ◆ *If they are dispatched with other parts, intermediate layers of cardboard or bubble plastic are to be used.*

Parts dispatch, notes on packaging and dispatch for export markets

To avoid delays if the battery cut-off relay and the adapter cable (if there is one) for right-hand drives have to be sent back,

make sure that the removed parts are immediately sent to the importer's collecting point.

Parts dispatch, notes on packaging and dispatch for German market

Make warranty/warranty claim immediately after removing the battery cut-off relay and/or the RHD adapter cable. Forward the part according to PDC guidelines.

Fill in section „Non-genuine parts“ completely and enter part number of the removed battery cut-off relay.

Type of dispatch	Parts recipient/location
OT Logistics	Via TSC to K-QS-62 Regresse GTR Halle 18 - Abt. 1958/4 38436 Wolfsburg

Notes on invoicing

Dispatch and labour costs are to be invoiced using special damage number „S 289 010 WWO“. For removing the battery cut-off relay and/or the RHD adapter cable 20 time units are credited.



4.7 Front passenger front airbag: Check key switch and „On/Off function“



Note

If the airbag is deactivated, the front airbag, side airbag and curtain airbag are deactivated on the front passenger side. All other airbags in the vehicle remain functional.



WARNING

It is only permissible to deactivate the front passenger airbags if, in exceptional cases, a child's seat has to be used on the front passenger seat

with the child sitting facing backwards.



Note

The „PASSENGER AIRBAG ON/OFF“ switch is located on the right end of dash panel.

Perform the following jobs:

- Check „ON/OFF function“ of key switch as follows:

Deactivating front passenger airbags (deactivated)

- Switch off ignition.
- Using the ignition key, turn key switch to position -1- „PASSENGER AIRBAG OFF“

The key slot must point in the direction of travel (forwards).

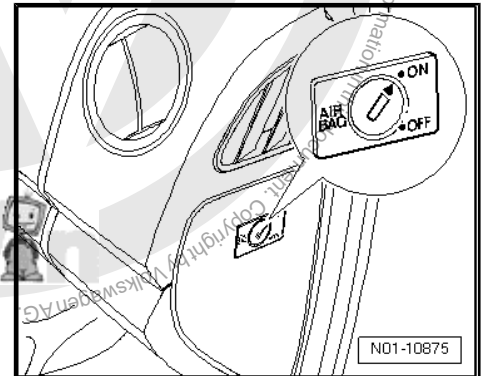

If ignition is switched on, warning lamp in dash panel „PASSENGER AIRBAG OFF“ -arrow- must light up continuously.

- Switch off ignition.

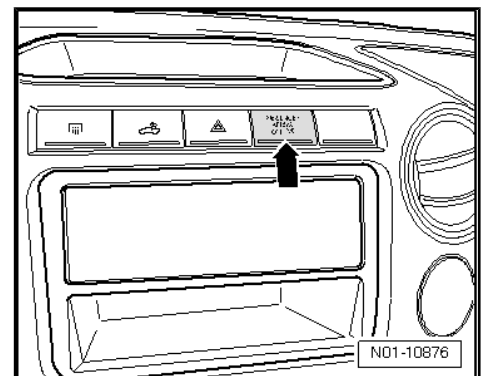



4.8 Checking tyres: Condition, wear pattern, tyre pressure, tread depth



Note

- ◆ *The following descriptions of work also apply to the spare wheel, if a spare wheel with standard tyres is fitted.*
- ◆ *For safety reasons, only tyres of same type and tread pattern should be fitted on a vehicle!*
- ◆ Check tyre age ⇒ [page 56](#)
- ◆ Tyre pressures (including spare wheel): Check, correct if necessary ⇒ [page 58](#)
- ◆ Checking wear pattern ⇒ [page 57](#)
- ◆ Tyre tread depth (including spare wheel): Check and enter ⇒ [page 57](#)
- ◆ Check condition ⇒ [page 56](#)

4.8.1 Check tyre age



Note

We recommend that summer or winter tyres older than 6 years should be taken out of service.



Note

The DOT number -arrow- is a number sequence stamped on at least one side of the tyre wall on motor vehicles which indicates the production date of the tyre.

The first two digits are for the calendar week (KW); shown as „02“ in this example.

The last two digits indicate the year of manufacture; shown as „04“ in this example.

In this case, therefore, „0204“ means that the tyre was produced in the second week of 2004.

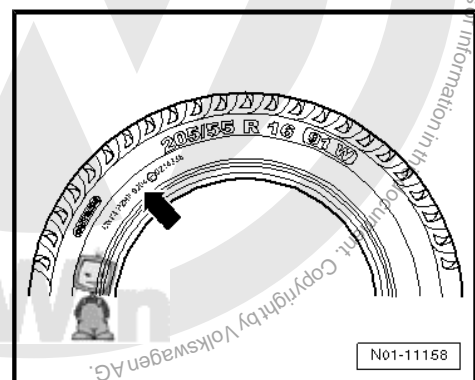

4.8.2 Checking condition of tyre

Tests at delivery inspection

Perform the following jobs:

- Check following areas of tyre for damage:
 - ◆ »Tyre treads«
 - ◆ »Tyre side walls«

**Note**

If damage is determined, always check to see if a new tyre should be fitted.

Tests at interval service**Perform the following jobs:**

- Check following areas of tyre for damage:
 - ◆ »Tyre treads«
 - ◆ »Tyre side walls«
- Remove foreign bodies from tyres such as nails and glass splinters if necessary.
- In addition, check the tyres for:
 - ◆ »Cupping«
 - ◆ »One-sided tread wear«
 - ◆ »Porous side walls«
 - ◆ »Cuts«
 - ◆ »Punctures«
 - ◆ »Tyre age« „DOT identification“ ^{1.)}

1.) Tyres that are more than 6 years old should be renewed (recommendation to customer)

**Note**

The customer must be informed of any faults found.

4.8.3 Checking wear pattern

The wear pattern on the front tyres will indicate, for example, if toe and camber settings should be checked:

- ◆ Feathering on tread indicates incorrect toe setting.
- ◆ One-sided tread wear is mainly attributed to incorrect toe and camber.

If wear of this nature is detected, determine cause by checking alignment (repair measure).

4.8.4 Tyre tread depth (including spare wheel): Check and enter

Perform the following jobs:

- Check tyre tread depth.

Minimum tread depth: 1.6 mm



Note

- ◆ This value may vary according to different legislation in individual countries.
- ◆ The minimum tread depth is reached when the tyres have worn down level with the 1.6 mm high tread wear indicators -arrows- positioned at intervals around the tyre.
- ◆ If the tread depth is approaching the minimum allowed depth, inform the customer.

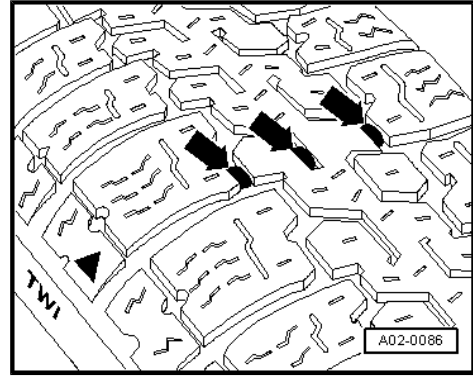

4.8.5 Tyre pressure (including spare wheel): Check using tyre inflator -VAS 5216- , correct tyre pressure if necessary

Special tools and workshop equipment required

- ◆ Tyre inflator -VAS 5216-



Note

- ◆ „Checking tyre inflation pressure“ also applies to the spare wheel, if a spare wheel with standard tyres is fitted.
- ◆ The pressures in the table apply to cold tyres. Do not reduce increased pressures of warm tyres.
- ◆ Winter tyres and summer tyres may be used with the same tyre sizes - check suitability for use with chains.
- ◆ Tyre pressures for the relevant model can also be found on a sticker attached to the inside of fuel tank flap.
- ◆ Values for pressure are indicated in „bar“.
- ◆ Adjust the tyre pressure to suit the vehicle load.
- ◆ Tyre pressures apply for all tyre sizes fitted in the factory.
- ◆ The tyre pressures indicated are valid when towing a trailer up to a speed of 130 km/h (if permitted).

Explanation for speed indexes used in the table:

- ◆ Q: up to 160 km/h
- ◆ R: up to 170 km/h
- ◆ S: up to 180 km/h
- ◆ T: up to 190 km/h
- ◆ H: up to 210 km/h



◆ V: up to 240 km/h

Tyre pressure table:

Applies to all factory-fitted tyre sizes.

Permitted axle load Full load: FA / RA (kg)	Type of tyre	Half payload		Full payload	
		front	rear	front	rear
1370 / 1860	◆ 205 R16 C 110/108 T • Summer tyres • M&S (winter tyres) • All Season (all-season tyres)	2,5	2,5	2,8	4,5
	◆ 245/70 R16,111 T • Summer tyres • M&S (winter tyres) • All Season (all-season tyres)	2,0	2,0	2,0	3,0
	◆ 245/65 R17,111 H • Summer tyres • M&S (winter tyres) • All Season (all-season tyres)	2,0	2,0	2,0	3,0
	◆ 255/60 R18,112 H • Summer tyres	2,0	2,0	2,0	3,0
	◆ 255/55 R19,111 H • Summer tyres • M&S (winter tyres)	2,0	2,0	2,0	3,5

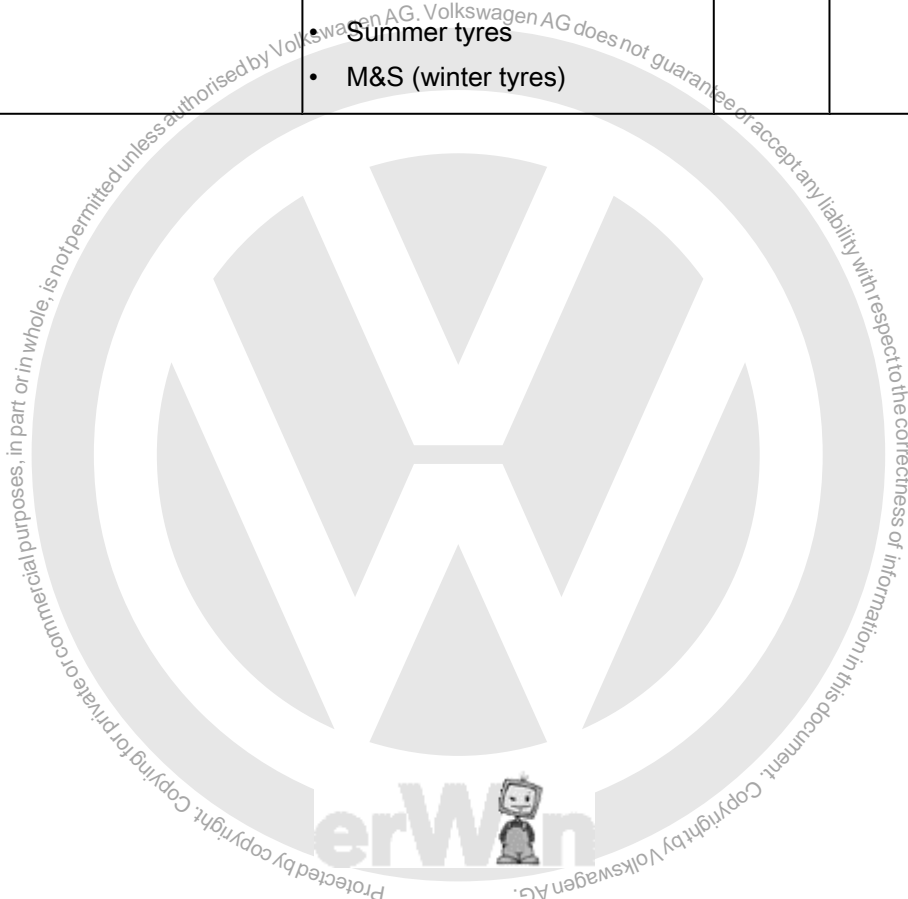



Permitted axle load Full load: FA / RA (kg)	Type of tyre	Half payload		Full payload	
1420 / 1860	◆ 205 R16 C 110/108 T • Summer tyres • M&S (winter tyres) • All Season (all-season tyres)	2,7	2,7	3,0	4,5
	◆ 245/70 R16,111 T • Summer tyres • M&S (winter tyres) • All Season (all-season tyres)	2,0	2,0	2,0	3,0
	◆ 245/65 R17,111 H • Summer tyres • M&S (winter tyres) • All Season (all-season tyres)	2,0	2,0	2,0	3,0
	◆ 255/60 R18 112 H • Summer tyres • M&S (winter tyres) • All Season (all-season tyres)	2,0	2,0	2,0	3,0
	◆ 255/55 R19 111 H • Summer tyres • M&S (winter tyres) • All Season (all-season tyres)	2,0	2,0	2,0	3,0

Spare wheel with standard tyres

The spare wheel should have the highest tyre pressure determined for the vehicle.

4.9 Brake system: Perform visual check for leaks and damage

– Check following components for leaks and damage:

- ◆ Brake servo,
- ◆ for anti-lock brake system: hydraulic unit,
- ◆ Brake calipers,
- ◆ Brake master cylinder.

Perform the following jobs:

- Make sure that brake hoses are not twisted ⇒ Brake hydraulic system, regulator, booster; Rep. gr. 47 .
- In addition, make sure that brake hoses do not contact other components across entire steering range.
- Check brake hoses for porosity or brittleness.
- Check brake hoses and lines for chafing.



- Check brake connections and fastenings for correct seating, leaks and corrosion.



WARNING

Faults found must always be rectified (repair measure).

4.10 Front brake pads/linings: Check thickness

Special tools and workshop equipment required

- ◆ Test pin -T40139-

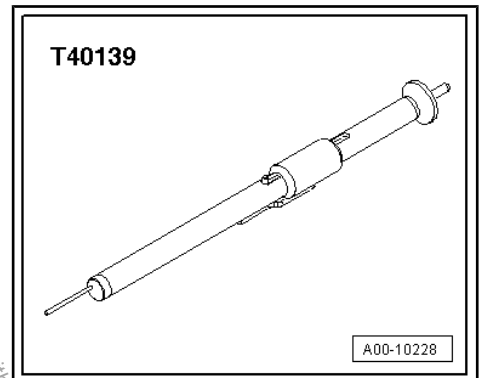

- ◆ Torque wrench -V.A.G 1332-

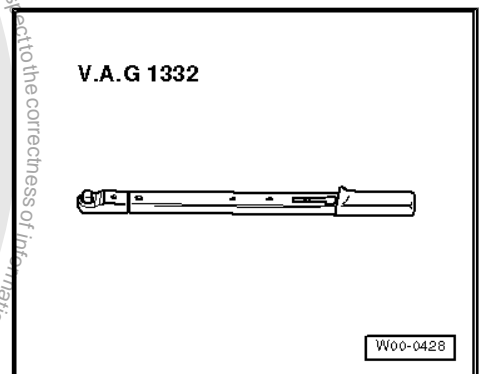

and, if necessary, if anti-theft wheel bolts are installed:

- ◆ Adapter set for tamper-proof wheel bolts -T10101-

Or

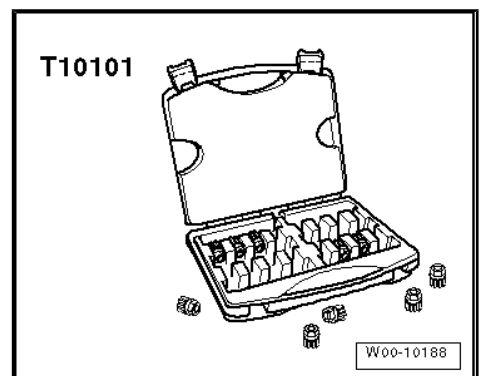



- ◆ Adapter set for tamper-proof wheel bolts -T10190-
- ◆ Electric hand torch and mirror

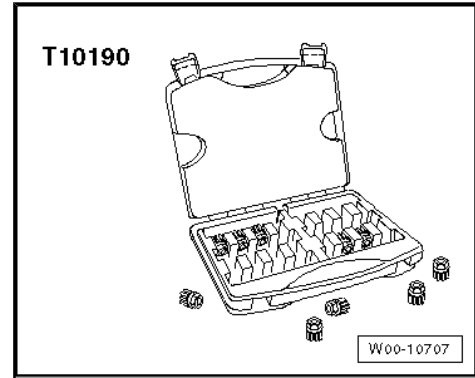

4.10.1 Front brake pads

Check thickness using test pin -T40139-



Note

- ◆ *The wheel rim geometry of some vehicles may make it impossible to*
- ◆ *insert the test pin through the wheel rim far enough to reach the brake disc or brake pad.*
- ◆ *In this case, determine the thickness of the brake pads by means of a visual check*
- ◆ *or remove the wheel on the driver's side to make it easier to assess or measure the remaining thickness of the pads.*

Perform the following jobs:

- To measure the brake pad thickness push the movable ring in direction of test probe onto stop.
- Insert the test probe of the test pin through the wheel rim until it touches the brake disc.
- Push the test pin towards the brake pad until the pin touches the rear plate of the brake pad.
- Then remove test pin -T40139- and read off value on scale identified with brake symbol.



Note

- ◆ *Ensure the movable ring is not moved when removing the test pin after the measurement. Otherwise this will lead to an incorrect measurement!*
- ◆ *The second scale (tyre symbol) on the test pin can be used to measure the tyre tread depth.*

a - Pad thickness „with“ backplate



Wear limit: 9 mm



WARNING

The brake pads have reached their wear limit at a brake pad thickness of 9 mm (value shown on test pin) (including back-plate) and must be renewed. Inform customer!

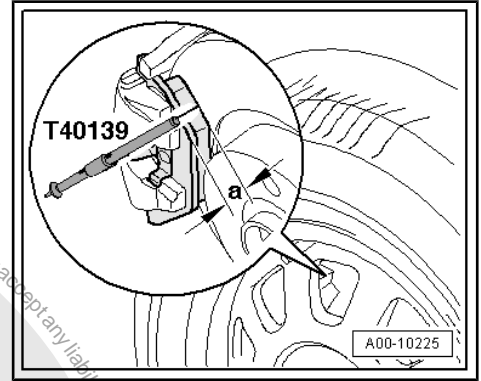

Note

When replacing disc brake pads, always check brake discs for wear! Checking and if necessary replacing the brake discs is a repair measure.

Checking brake disc for wear ⇒ Rep. gr. 46 .

Check thickness by visual check



Note

On some vehicles it may be very difficult to ascertain or measure the thickness of the pad due to the geometry of the wheel rim. If this is the case, remove the wheel on driver side for better evaluation of the remaining pad thickness.

Perform the following jobs:

- Measure outer and inner brake pad thickness by visually checking through the holes of wheel rim (depending on type).
- If necessary, remove the wheel on the driver's side to make it easier to assess or measure the remaining thickness of the pads.
- Mark position of wheel in relation to brake disc, in order to avoid imbalances on vehicle wheel.
- Unscrew wheel securing bolts and remove wheel.



- Assess or measure inner and outer pad thickness.

a - Pad thickness „without“ backplate

Wear limit: 2 mm



WARNING

The brake pads have reached their wear limit at a brake pad thickness of 2 mm (without backplate) and must be renewed (repair measure). Inform customer!

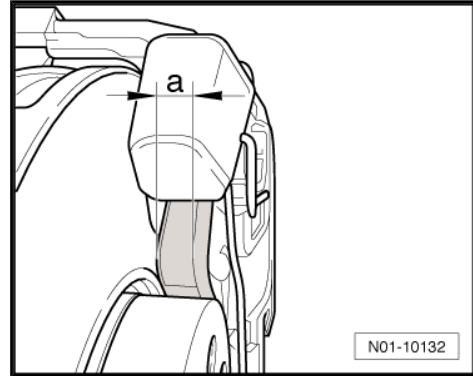

Note

When replacing disc brake pads, always check brake discs for wear! Checking and if necessary replacing the brake discs is a repair measure.

Checking brake disc for wear ⇒ Rep. gr. 46 .

Perform the following procedure:

- If necessary, secure wheel in marked position.
- Tighten wheel securing bolts diagonally across to following specified torque:

Specified torque: 180 Nm

- Push on wheel trims if necessary.

4.11 Rear drum brake linings: Check thickness

Special tools and workshop equipment required

- ◆ Fluorescent lamp, 13 watts -VAS 6485-

Or

- ◆ Conventional torch

Perform the following procedure:

- Remove inspection hole cover
- Check brake lining thickness through inspection holes -arrow- in brake backplates.

Wear limit: 1.5 mm (lining thickness only).



Note

Check linings for brake fluid or grease contamination.

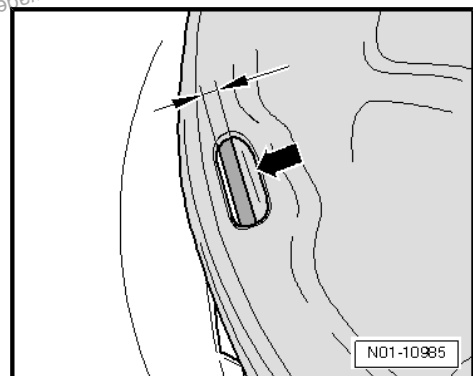



4.12 Brake system and shock absorbers: Perform visual check for leaks and damage

Check following components for leaks and damage:

- ◆ Brake master cylinder
- ◆ Hydraulic unit
- ◆ Brake calipers
- ◆ Shock absorber
- ◆ Presence of dust caps on brake fluid bleeder valves
- Ensure that brake hoses are not twisted.
- Additionally ensure that brake hoses do not touch any vehicle components when steering is at full lock.
- Check brake hoses for porosity or brittleness.
- Check brake hoses and lines for chafing.
- Also check brake connections and fastenings for correct seating, leaks and corrosion.



WARNING

Faults found must always be rectified (repair measure).

4.13 Brake fluid: Change

- ◆ Observe brake fluid specification ⇒ [page 69](#)



WARNING

- ◆ ***Brake fluid must under no circumstances come into contact with fluids containing mineral oils (oil, petrol, cleaning solutions). Mineral oils will damage seals and sleeves of brake system.***
- ◆ ***Brake fluid is poisonous. In addition, due to its corrosive nature, it must not come into contact with paint.***
- ◆ ***Brake fluid is hygroscopic, i.e. it attracts moisture from the surrounding air and therefore must always be stored in airtight containers.***
- ◆ ***Wash away spilt brake fluid using plenty of water.***
- ◆ ***Do not reuse extracted (used) brake fluid!***
- ◆ ***Observe disposal regulations!***

Special tools and workshop equipment required



◆ Brake filling and bleeding equipment -VAS 5234-

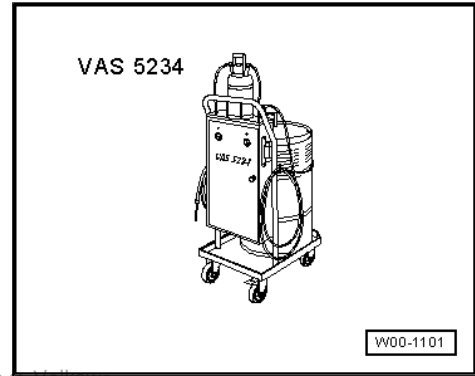

◆ Brake pedal actuator -V.A.G 1869/2-

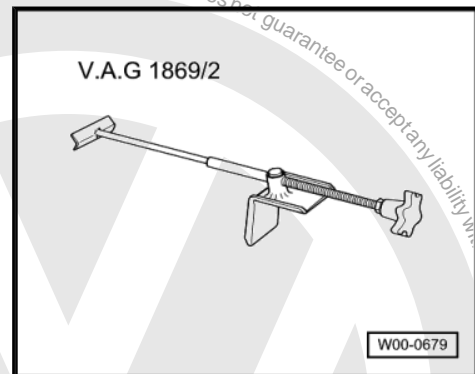

◆ Upgrade kit and extraction unit -V.A.G 1869/4-

Perform the following procedure:

- Unscrew sealing cover -1- from brake fluid reservoir -2-.



Note

The strainer in brake fluid reservoir must not be removed.

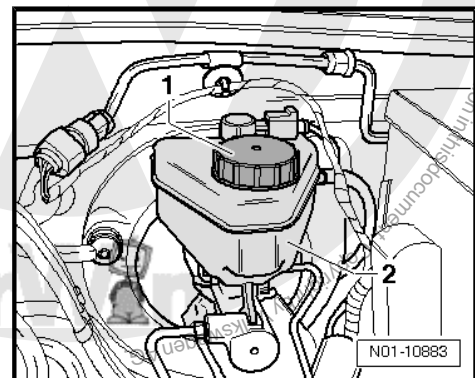



- Extract as much brake fluid as possible using suction hose from brake filling and bleeding equipment -VAS 5234- .



WARNING

Do not reuse extracted (used) brake fluid!

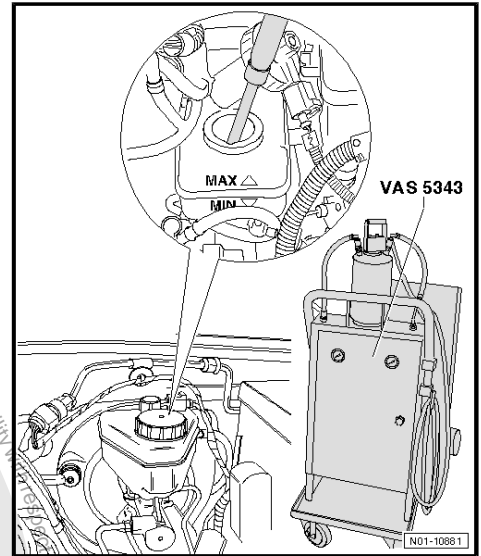

- Screw adapter -1- onto brake fluid reservoir -2-.
- Fit brake pedal actuator -V.A.G 1869/2- between driver seat and brake pedal and pretension.
- Connect filler hole from brake filling and bleeding equipment -VAS 5234- to adapter.



Note

Observe => operating instructions for brake filling and bleeding equipment -VAS 5234- !

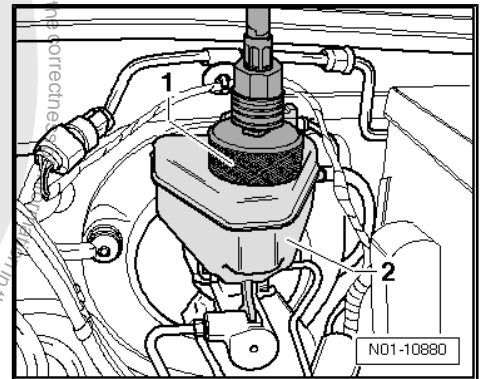

WARNING

Use an appropriate bleeder hose. It must seat tightly on bleeder valve so that no air can enter the brake system.

Change brake fluid in clutch slave cylinder.

Bleeder valve for clutch slave cylinder is located on left side of gearbox.

- Pull cover cap off bleeder valve of clutch slave cylinder -arrow-.
- Push collector bottle bleeder hose onto bleeder valve of clutch slave cylinder.
- Open bleeder valve and allow approx. 0.1 litre or 100 cm³ to flow out.
- Close bleeder valve and quickly operate foot pedal 10 to 15 times from stop to stop.
- Open bleeder valve and allow another 0.05 litre or 50 cm³ of brake fluid to flow out.
- Close bleeder valve and push on cover cap.
- Press clutch pedal rapidly several times.
- Remove caps from bleed valves of brake calipers.

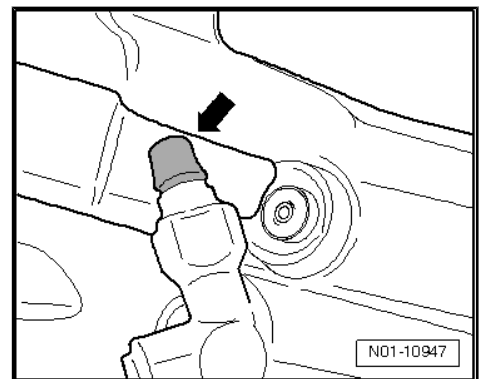

Changing brake fluid at rear.



- Push collector bottle bleed hose -1- onto rear right bleed valve.
- Open bleeder valve and let appropriate quantity of brake fluid run out (see table).

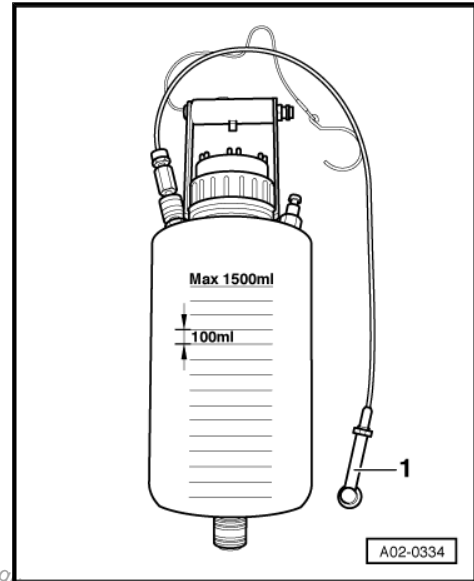

- Close bleeder valve again.
- Repeat procedure on rear left of vehicle.

Change brake fluid at front.

- Push collector bottle bleeder hose -1- onto front right-hand bleeder valve, open bleeder valve and allow appropriate amount of brake fluid to flow out out (see table).

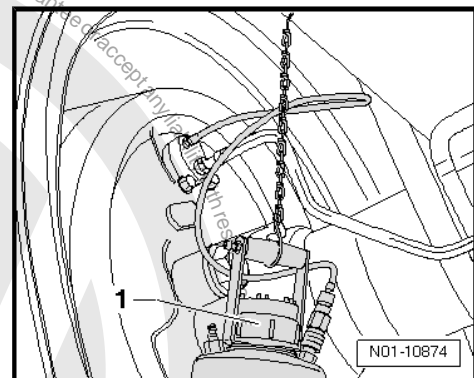

- Close bleeder valve again.
- Repeat procedure on front left of vehicle.

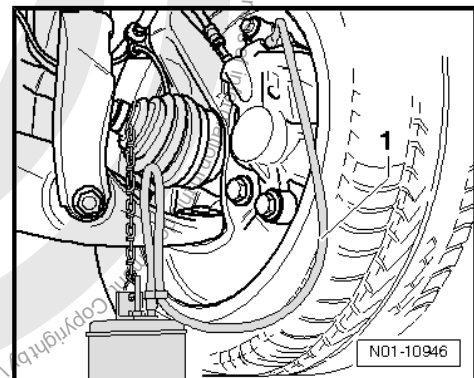

Sequence	Recommended quantity of brake fluid to be changed
On clutch slave cylinder ¹⁾	approx. 0.15 litre
Rear right	approx. 0.25 litre
Rear left	approx. 0.25 litre
Front right	approx. 0.25 litre
Front left	approx. 0.25 litre

¹⁾ Only vehicles with manual gearbox

- Brake fluid quantity to be changed: approx. 1.0 to 1.15 litre (depending on vehicle equipment)



Final checks

- Fit cover caps on bleeder valves of brake calipers.
- Set fill lever of brake filling and bleeding equipment - VAS 5234- to position „B“ (see ⇒ operating instructions).
- Remove filler hose from adapter.
- Unscrew adapter from brake fluid reservoir.
- Check brake fluid level and correct it if necessary.
- Screw on sealing cover -1- of brake fluid reservoir -2-.
- Remove brake pedal actuator.
- Check pressure and free travel of brake pedal.

Free play: max. $\frac{1}{3}$ of pedal travel.

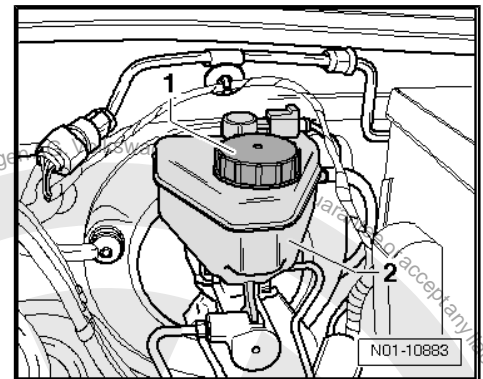

4.13.1 Brake fluid specification

The brake fluids are available as replacement part. The part number can be found in ⇒ Electronic parts catalogue „ETKA“ .

Permissible brake fluid specifications

- ◆ Volkswagen recommends using new brake fluid acc. to VW Standard 501 14 for optimum function of brake system.
- ◆ Alternatively, a brake fluid acc. to requirements of US standard FMVSS 116 DOT4 or DIN ISO 4925 Class 4 can be used.
- ◆ Specification is stated on brake fluid packaging.

4.14 Brake fluid level: Check

- ◆ Checking brake fluid level at delivery inspection ⇒ [page 70](#)
- ◆ Checking brake fluid level at interval service and inspection service ▶ 2010 ⇒ [page 70](#)
- ◆ Observe brake fluid specification ⇒ [page 69](#)



WARNING

- ◆ **Brake fluid must under no circumstances come into contact with fluids containing mineral oils (oil, petrol, cleaning solutions). Mineral oils will damage seals and sleeves of brake system.**
- ◆ **Brake fluid is poisonous. In addition, due to its corrosive nature, it must not come into contact with paint.**
- ◆ **Brake fluid is hygroscopic, i.e. it attracts moisture from the surrounding air and therefore must always be stored in airtight containers.**
- ◆ **Wash away spilt brake fluid using plenty of water.**
- ◆ **Observe disposal regulations!**



4.14.1 Checking brake fluid level at delivery inspection

At delivery inspection the fluid level must be at MAX. marking -1-.



Note

In order that brake fluid does not overflow the reservoir, MAX marking -1- must not be exceeded.

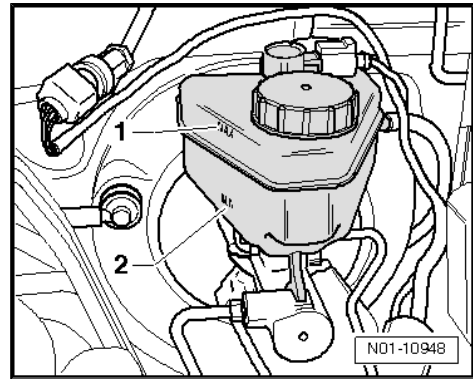

4.14.2 Checking brake fluid level at interval service and inspection service



Note

- ◆ *The fluid level must always be judged in conjunction with lining/pad wear.*
- ◆ *When vehicle is in use, fluid level tends to drop slightly due to lining/pad wear and automatic adjustment.*

Recommended brake fluid level „BEFORE“ brake pads are at wear limit:

- „At MIN marking or just above“, -2-

Then „REPLENISHING IS NOT REQUIRED!“

Recommended brake fluid level, brake pads new or well within wear limit:

- „Between MIN. and MAX. marking“

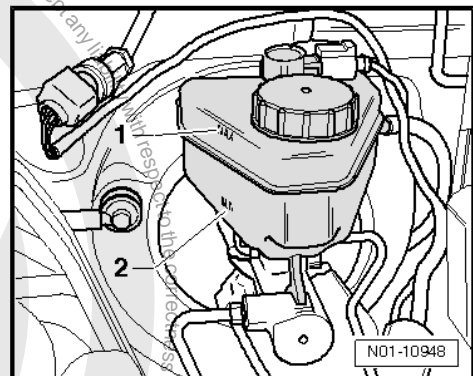

WARNING

If fluid level is below MIN marking -2-, the brake system must be checked before fluid is topped up, „Repair measure“!

4.15 Climatronic: Set temperature to 22 °C



Note

The automatic air conditioning system „Climatronic“ only functions when engine is running and the blower is switched on.

Perform the following jobs:

- Switch on ignition.
- Check the temperature controllers -2- and -3- to see whether the temperature has been set to 22 °C.

If temperature is not set to 22 °C, then correct it.



- Press **AUTO** -1- The „AUTO High“ function (high blower output) has been activated. The right-hand warning lamp in the button lights up.
- Press **AUTO** -1- again. The „AUTO Low“ function (low blower output) has been activated. The left-hand warning lamp in the button lights up.
- Turn the temperature controllers -2- and -3- to set the desired temperature for the left-hand and right-hand sides of the interior.

22 °C is recommended.



Note

In the automatic mode the air temperature, air quantity and air distribution are regulated automatically so that a specified temperature level is attained as quickly as possible and is maintained constantly.

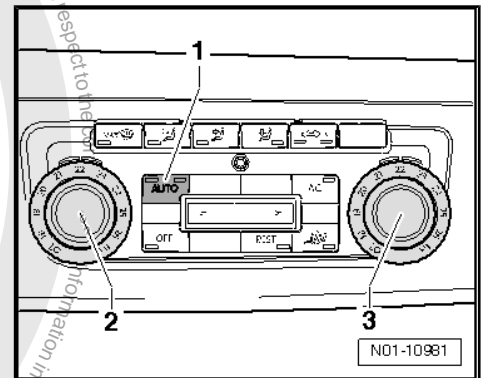

4.16 Window regulators: Check positioning (open and close functions)



WARNING

After batteries have been disconnected and reconnected the roll-back function of the window regulators is disabled. Severe pinching injuries could result!



Note

- ◆ *The automatic opening and closing functions of the electric windows do not work after the batteries have been disconnected and reconnected.*
- ◆ *Therefore, with immediate effect, before a new vehicle is delivered, the window regulators must be reactivated.*
- ◆ *Once the windows have been repositioned, the batteries must not be disconnected again.*

Perform the following jobs:

- Close all doors and windows completely.
- Insert key in driver's door lock and lock vehicle from outside.
- Unlock vehicle again.
- Lock vehicle again from outside and hold key in lock position for at least 1 second.

The one-touch opening and closing function is now ready for use.

4.17 Connecting vehicle diagnosis tester

- ◆ Connect vehicle diagnostic, testing and information system - VAS 5051B- or vehicle diagnostic and service information system -VAS 5052 A- and select functions ⇒ [page 72](#)



4.17.1 Connect vehicle diagnostic, testing and information system -VAS 5051B- or vehicle diagnostic and service information system -VAS 5052 A- and select functions

Special tools and workshop equipment required

- ◆ Vehicle diagnostic, testing and information system -VAS 5051B- or subsequent units

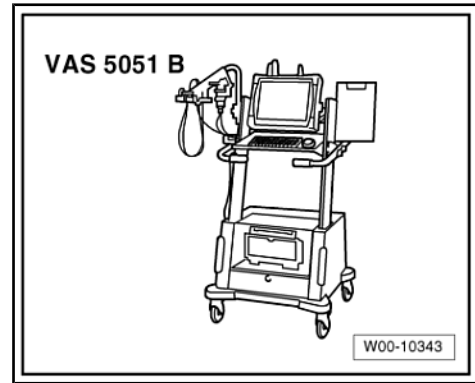

- ◆ Diagnosis cable 5m -VAS 5051B/1-

Or

- ◆ Diagnosis cable -VAS 5051/5A-

Or





- ◆ Vehicle diagnostic and service information system -VAS 5052 A-
 - ◆ Diagnosis cable, 2 m -VAS 5052/3 A-
- Or
- ◆ Diagnosis cable, 5 m -VAS 5052/3 A-1-



Note

- ◆ *Observe current operating instructions for vehicle diagnostic, testing and information system -VAS 5051B- or vehicle diagnostic and service information system -VAS 5052 A-, which are shown on display after selecting the functions Administration and Operating manual.*
- ◆ *For diagnosis only use the diagnosis cable indicated above, because this is fitted with CAN bus cables and allows a CAN diagnosis or CAN communication.*
- ◆ *For a road test use diagnostic cable -VAS 5051/5A-, to guarantee the voltage supply of the vehicle diagnostic, testing and information system -VAS 5051B-.*

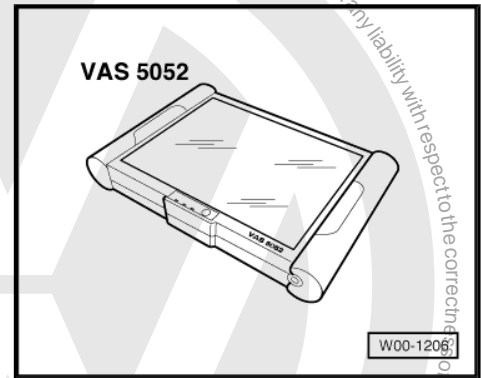

WARNING

- ◆ *If the vehicle diagnosis tester is placed within the range of action of an airbag during a test or measuring run,*
- ◆ *there is a risk of severe or fatal injury should an airbag be triggered!*
- ◆ *During the road test, take another person with you who can operate the vehicle diagnosis tester from the rear seat.*
- ◆ *Always secure testing and measuring equipment on the rear seat during a road test.*

Perform the following jobs:



- Connect diagnosis cable connector to diagnosis connection with ignition switched off.
- Switch on tester.
- Switch on ignition.
- Touch the field on the screen for **Guided fault finding** or **Guided functions**.
- Select one after another:
 - ◆ Brand
 - ◆ Type
 - ◆ Model year
 - ◆ Version
 - ◆ Engine code
- Confirm entered data.

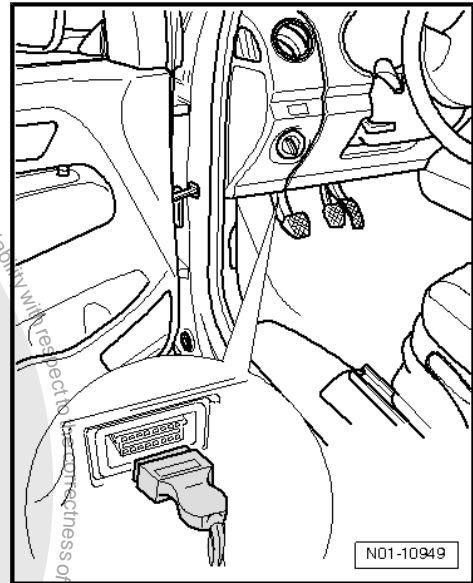

 **Note**

Wait until tester has read all control units in vehicle.

- Press **GoTo** button and select **Function/component selection** function.

Now follow screen display to start desired functions.

4.18 Performing vehicle system test

- Connect vehicle diagnostic, testing and information system - VAS 5051B- or vehicle diagnostic and service information system -VAS 5052 A- ⇒ [page 71](#) .

 **Note**

*Observe current operating instructions for vehicle diagnostic, testing and information system -VAS 5051B- or vehicle diagnostic and service information system -VAS 5052 A-, which are shown on display after selecting the functions **Administration** and **Operating manual**.*



WARNING

- ◆ ***If the vehicle diagnostic, testing and information system -VAS 5051B- or the vehicle diagnostic and service information system -VAS 5052 A- is placed in the range of action of an airbag during a test or measuring run,***
- ◆ ***there is a risk of severe or fatal injury should an airbag be triggered!***
- ◆ ***During the road test take another person with you who can operate the vehicle diagnostic, testing and information system -VAS 5051B- or vehicle diagnostic and service information system -VAS 5052 A- from the rear seat.***
- ◆ ***Always secure testing and measuring equipment on the rear seat during a road test.***



Note

If faults are stored, the respective event memory must not be cleared.

Reason:

If the subsequent fault finding (repair measure) is performed using vehicle diagnosis, testing and information system -VAS 5051B- or vehicle diagnosis and service information system -VAS 5052 A- in operating mode Guided fault finding, the device reads the event memories again. The vehicle diagnosis, testing and information system -VAS 5051B- or vehicle diagnosis, testing and information system -VAS 5052 A- can generate a test plan for „Guided fault finding“ but only if the faults are still stored in the event memory.

Perform the following jobs:

- Pull on handbrake.
- Manual gearbox: Gear lever in **neutral**.
- Switch on ignition.
- Select Guided functions operating mode -arrow- on display of vehicle diagnostic, testing and information system -VAS 5051B- or vehicle diagnostic and service information system -VAS 5052 A- .

Indicated on display:

- Then perform vehicle identification on vehicle diagnostic, testing and information system -VAS 5051B- or vehicle diagnostic and service information system -VAS 5052 A- .
- Select one after another:
 - ◆ Brand
 - ◆ Type
 - ◆ Model year
 - ◆ Version
 - ◆ Engine code
- Confirm vehicle identification
- If the vehicle identification has been performed correctly, confirm with  button.

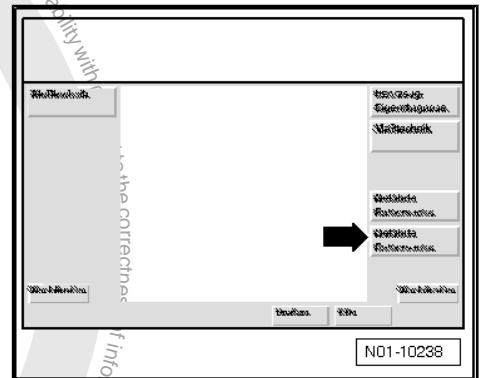



Indicated on display:

- Select **Vehicle system test** function -arrow- on display of vehicle diagnostic, testing and information system -VAS 5051B- or vehicle diagnostic and service information system -VAS 5052 A- .
- Start system test by selecting function **Start system test** on display of vehicle diagnostic, testing and information system -VAS 5051B- or vehicle diagnostic and service information system -VAS 5052 A- .

Now the event memories of all control units for this type of vehicle are automatically read and any faults stored will be listed.

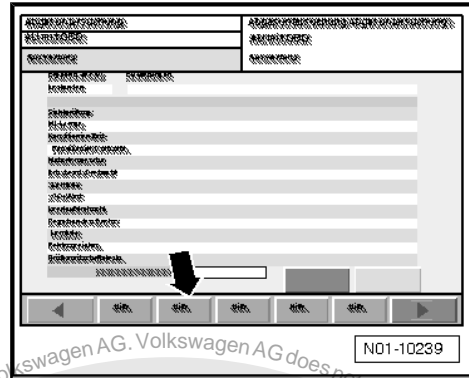

Note

- ◆ *If any stored faults are listed, it is useful at this point to change to the **Guided troubleshooting** mode*
 - ◆ *in order to continue working with the vehicle diagnostic, testing and information system -VAS 5051B- or vehicle diagnostic and service information system -VAS 5052 A- and avoid the tester having to perform a second vehicle identification check.*
 - ◆ *When the system test indicates the need for a repair measure (fault finding) and this is to be performed immediately, change to operating mode **Guided fault finding**.*
 - ◆ *If the repair measure is to be carried out at a later date, e.g. after completing servicing, end operating mode **Guided functions**. The event memory will not be cleared.*
 - ◆ *Follow the instructions of the vehicle diagnosis, testing and information system -VAS 5051B- or vehicle diagnosis and service information system -VAS 5052 A- on how to proceed for „Guided find finding“ or „Guided functions“.*
- End the system test via function **GoTo** and **End** or continue „Guided fault finding“ after changing the operating mode.



Caution

The vehicle must always be delivered to the customer with event memory cleared.

Static faults

If one or more static faults have been stored in the event memory, it is advisable to rectify these faults with the help of „Guided troubleshooting“ in consultation with the customer.

Sporadic faults

If only sporadic faults or notes have been stored in the event memory

and the customer makes no complaints regarding an electronic vehicle system, the event memory is to be erased.

Clear event memory.

- Start operating mode **Vehicle self-diagnosis** in the system start mask of the vehicle diagnostic, testing and information system -VAS 5051B- or vehicle diagnostic and service information system -VAS 5052 A- .



There are two ways to clear the event memory:

- ◆ Clearing event memory by selecting individual control units:

Perform the following jobs:

- Select control unit in question individually in overview, select Read event memory and then press Delete event memory.

- ◆ Clearing event memory via function Collection services:

Perform the following jobs:

- Call up Collection services on display,
- and then select Delete event memory function.



Note

- ◆ *If all faults have been cleared, it is shown on display.*
- ◆ *The diagnosis log can be sent automatically »online«.*

The vehicle system test is completed.

4.19 Four-wheel drive: Insert fuse

Insert fuse 46 on fuse holder C -SC46- „4 x 4“ four-wheel drive control unit

Special tools and workshop equipment required

- ◆ Vehicle diagnostic, testing and information system -VAS 5051B- or subsequent units

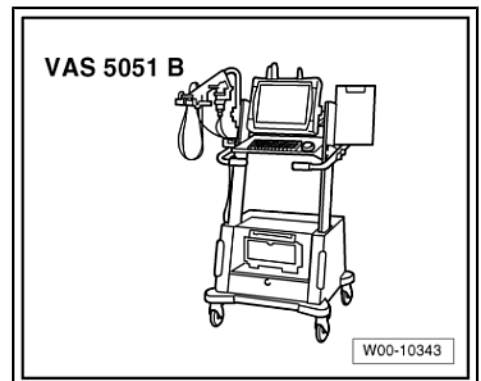

- ◆ Diagnosis cable 5m -VAS 5051B/1-

Or

- ◆ Diagnosis cable -VAS 5051/5A-

Or

- ◆ Vehicle diagnostic and service information system -VAS 5052 A-

- ◆ Diagnosis cable, 2 m -VAS 5052/3 A-

Or

- ◆ Diagnosis cable, 5 m -VAS 5052/3 A-1-

Perform the following jobs:

- Switch off ignition, all electrical consumers and withdraw ignition key.

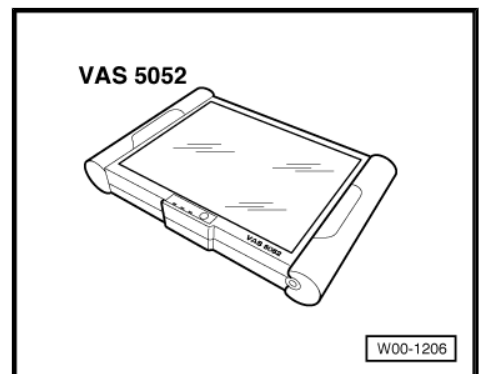



- Release fuse holder C -SC- -1- -arrows- and fold down fuse holder C -SC- .

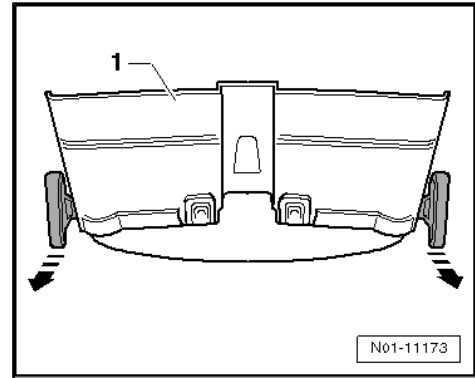

- Remove „SC fuse / 25 A“ -arrow-, which is attached to dash panel insert -K- .

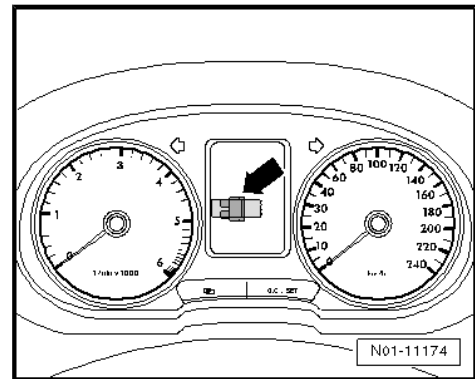

- Place fuse 46 on fuse holder C -SC46- in fuse holder C -SC- -1- -arrow-, using removed insertion aid if necessary.
- Replace insertion aid where it belongs if it has been removed.
- Fold up fuse holder C -SC- and lock in place.

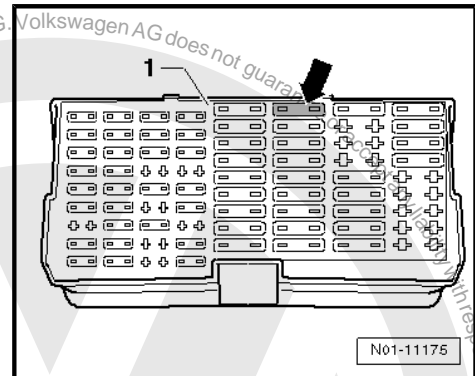

- Switch on ignition and check if both warning lamps „4 x 4 high / 4 x 4 low“ -arrow- in dash panel insert -K- no longer light up.
- Switch off ignition.

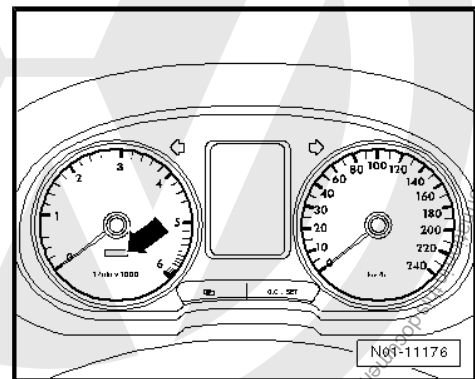



- Connect vehicle diagnostic, testing and information system -VAS 5051B- or vehicle diagnostic and service information system -VAS 5052 A- → [page 71](#) .

i Note

- ◆ *Observe current operating instructions for vehicle diagnostic, testing and information system -VAS 5051B- or vehicle diagnostic and service information system -VAS 5052 A- , which are shown on display after selecting the functions Administration and Operating manual.*
- ◆ *For diagnosis only use the diagnosis cable indicated above, because this is fitted with CAN bus cables and allows a CAN diagnosis or CAN communication.*

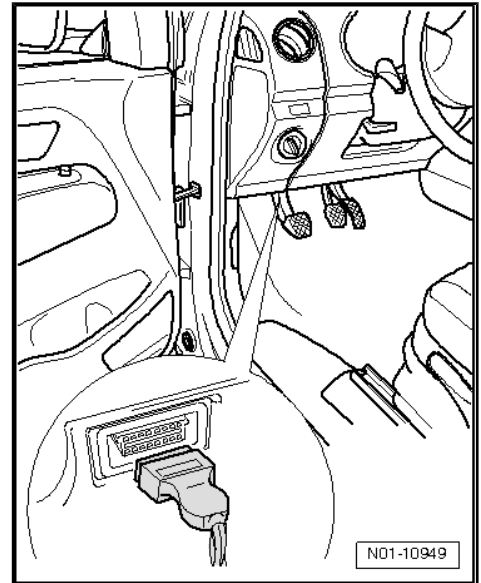

WARNING

- ◆ *If the vehicle diagnosis tester is placed within the range of action of an airbag during a test or measuring run,*
- ◆ *there is a risk of severe or fatal injury should an airbag be triggered!*
- ◆ *During the road test, take another person with you who can operate the vehicle diagnosis tester from the rear seat.*
- ◆ *Always secure testing and measuring equipment on the rear seat during a road test.*

- Switch on ignition.
- Connect vehicle diagnosis, testing and information system -VAS 5051B- or vehicle diagnostic and service information system -VAS 5052 A- .
- Start operating mode Vehicle self-diagnosis in the system start mask of the vehicle diagnostic, testing and information system -VAS 5051B- or vehicle diagnostic and service information system -VAS 5052 A- .
- Select respective control unit „03 - Brake electronics“, „17 - Dash panel insert“ and „19 - Gateway / data bus“ individually in the overview.
- Select Read event memory function and then Erase event memory.

i Note

If all faults have been cleared, it is shown on display.

The vehicle system test is completed.

- Switch off ignition and disconnect vehicle diagnosis, testing and information system -VAS 5051B- or vehicle diagnostic and service information system -VAS 5052 A- .
- Remove vehicle diagnosis, testing and information system -VAS 5051B- or vehicle diagnostic and service information system -VAS 5052 A- from vehicle.



4.20 Protective bellows: Visual check

Perform the following jobs:

- Check outer and inner CV joint boots -arrows- for leaks and damage.

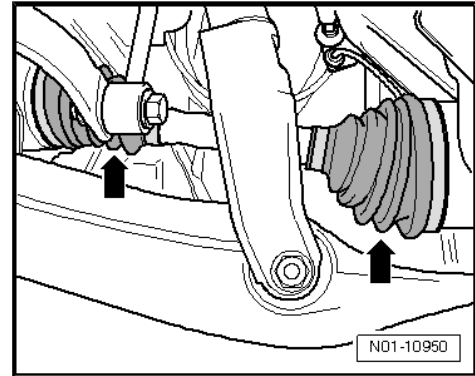

4.21 Dust and pollen filter: Clean housing and renew filter element



Note

Before installing the new filter, clean area around the dust and pollen filter in the heater and air conditioner unit.

Removing

The filter is located in front passenger footwell.

Perform the following jobs:

- Unscrew bolts -1- and open cover -2- downwards.

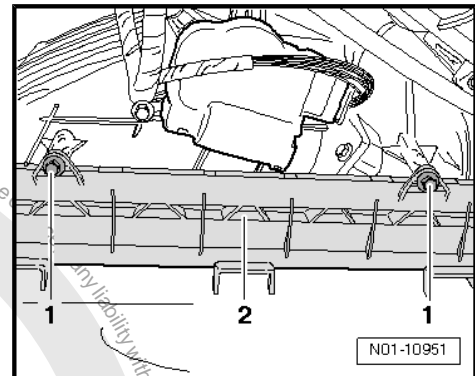

- Remove filter element -1- downwards.



Note

Observe disposal regulations!

Installing

Perform the following jobs:



Note

Note installation position.

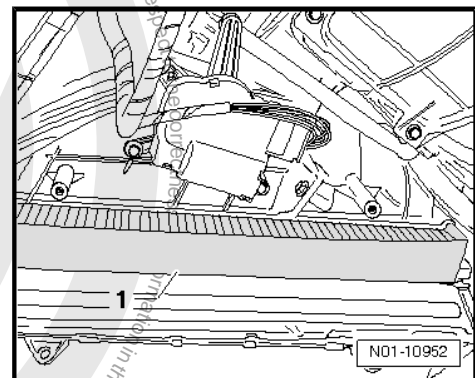



Observe installation position of filter element -arrows-.

- Insert new filter -1-.

- Close cover -2- and bolt on with bolts -1-.

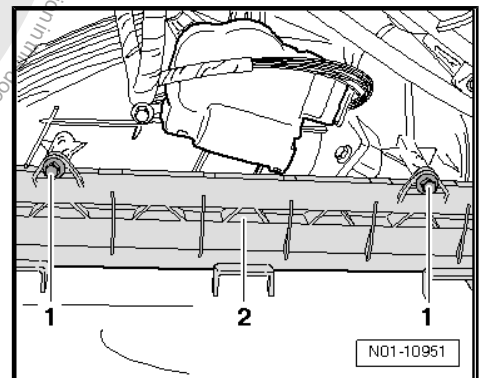
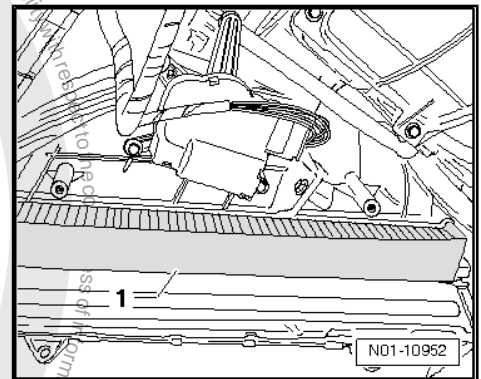
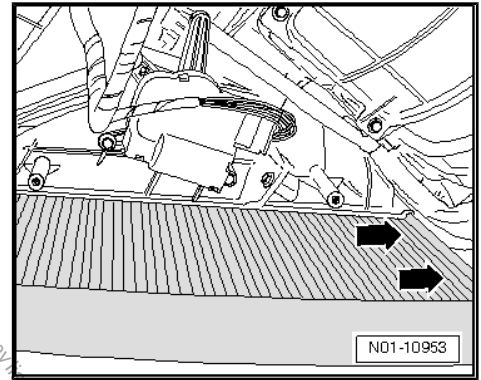

4.22 Poly V-belt: Check condition

Perform the following jobs:

- Use a socket spanner to turn the engine at the vibration damper/pulley.



- Check poly V-belt -1- for:
- ◆ Substructure cracks (cracks, core ruptures, cross sectional breaks)
- ◆ Layer separation (top layer, cord strands)
- ◆ Base break-up
- ◆ Fraying of cord strands
- ◆ Flank wear (material wear, frayed flanks, brittle flanks -glassy flanks-, surface cracks)
- ◆ Traces of oil and grease

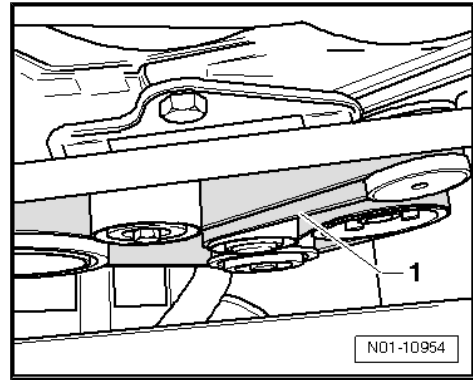

Note

If faults are found it is absolutely necessary to renew the poly V-belt. This will avoid possible breakdowns or operating problems. Renewing the poly V-belt is a repair measure.

4.23 High pressure pump: Check

- The procedure is described in workshop manual ⇒ Rep. gr. 24 .

4.24 Poly V-belt: Renew

- The procedure is described in workshop manual ⇒ Rep. gr. 13 .

4.25 Fuel filter: Renew (diesel engine)



Caution

The fuel system must also be vented after replacement of the common rail high-pressure pump and all components that are upstream of the common rail high-pressure pump in the low-pressure fuel system.

For example, fuel filter, fuel lines etc.

The electric fuel pump must be activated once for at least 60 seconds when components that are upstream from the common rail high-pressure pump are replaced.

When the common rail high-pressure pump itself is replaced, the electric fuel pump should be activated for approx. 180 seconds.

(to be done several times according to need).

Fuel system: Bleed (diesel engine) ⇒ [page 83](#) .

Removing

Perform the following jobs:

Fuel filter is located on inside of left longitudinal member under vehicle in area ahead of pedal floor.



- To pull off lines -1- press release buttons on connecting pieces of fuel filter -2-.

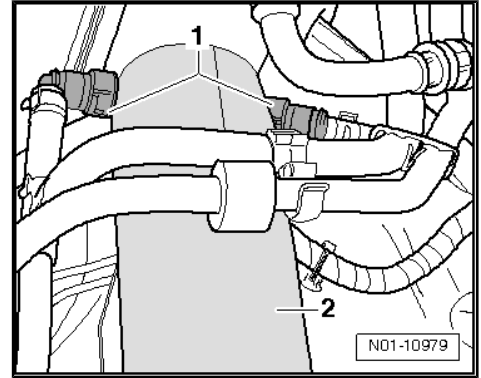

- To remove fuel filter -1-, press fuel filter from below -movement arrow- upwards out of holder -2- and remove it downwards.

Installing

Perform the following jobs:



Note

- ◆ Note installation position of fuel filter!
- ◆ Note fuel line identification on fuel filter!
- ◆ Observe disposal regulations!

- Insert new fuel filter into bracket.

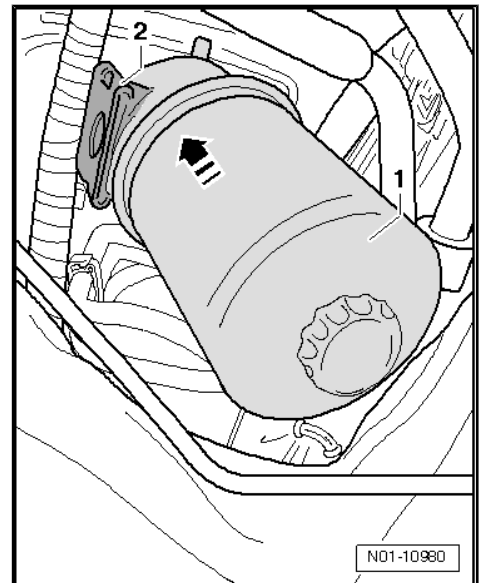

- Push fuel lines -1- onto fuel filter connection. When doing this ensure that fuel lines are seated securely on fuel filter.
- Fuel system: Bleed (diesel engine) => [page 83](#) .
- Start engine and conduct a visual check of fuel system on fuel filter.

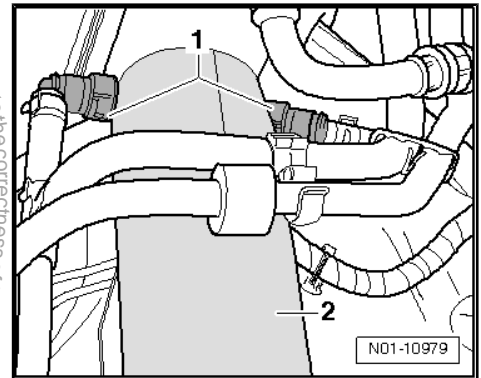

Note

To ensure the engine starts immediately after changing the fuel filter, bleed the fuel system using vehicle diagnostic, testing and information system -VAS 5051B- or vehicle diagnostic and service information system -VAS 5052 A- => [page 83](#) .

4.26 Fuel system: Bleed (diesel engine)

Using vehicle diagnostic, testing and information system -VAS 5051B- or vehicle diagnostic and service information system -VAS 5052 A-

To ensure the engine starts immediately after changing the fuel filter, bleed the fuel system using vehicle diagnostic, testing and information system -VAS 5051B- or vehicle diagnostic and service information system -VAS 5052 A- .



Perform the following jobs:

- Connect vehicle diagnostic, testing and information system - VAS 5051B- or vehicle diagnostic and service information system -VAS 5052 A- with ignition switched off ⇒ [page 71](#) .
- Switch on ignition.
- Press the **Guided functions** button on the display.
- Then perform vehicle identification.
- Select following functions one after another:
 - ◆ „Systems capable of self-diagnosis“
 - ◆ „Diesel direct injection and glow plug system“
 - ◆ „Functions“
 - ◆ „Bleeding fuel system“
- Follow instructions on display of vehicle diagnostic, testing and information system -VAS 5051B- or vehicle diagnostic and service information system -VAS 5052 A- .
- After bleeding the fuel system, exit „Guided functions“ using **GoTo** button.
- Touch function **End** on display.
- Select function **End** in „End menu“.
- Switch off ignition.
- Disconnect diagnosis connector from vehicle.

Bleeding the fuel system is finished.

4.27 Fuel filter: Drain water (diesel engine)

Perform the following jobs:

- Unscrew drain plug from bottom end of filter and collect approx. 100 ml of fuel into a suitable container.
- Screw drain plug back in, if necessary first fitting it with a new seal if the old one was damaged.



Note

Observe disposal regulations!

4.28 Cooling system: Check frost protection and coolant level



Caution

Only distilled water may be used for mixing G12 plus-plus. The use of distilled water enables the optimal level of corrosion protection to be reached.



Note

- ◆ From model year 2008 all engines are filled with coolant additive G 12 Plus Plus (purple). G 12 Plus Plus can be mixed with coolant additives G 11 (green), G 12 (red) and G 12 Plus (purple)! But because of its positive characteristics, ensure that only G 12 Plus is used when replenishing.
- ◆ G 12 Plus Plus is suitable as a filled-for-life filling for cast iron and all-aluminium engines and gives optimum protection against frost, corrosion damage, scaling and overheating.
- ◆ G 12 Plus Plus raises the boiling point and ensures better heat dissipation.
- ◆ The coolant concentration must be at least 40 % (frost protection to -25 °C) and should never exceed 60 % (frost protection to -40 °C). Otherwise both frost protection and cooling efficiency will be reduced.
- ◆ Frost protection must be assured to about -25 °C (in arctic climatic countries to about -35 °C).
- ◆ Check frost protection, if necessary replenish coolant additive ⇒ [page 85](#)
- ◆ Check coolant level, replenish coolant if necessary ⇒ [page 87](#)
- ◆ Mixture ratio ⇒ [page 87](#)
- ◆ Mixing coolants ⇒ [page 86](#)

4.28.1 Checking frost protection, if necessary replenish coolant additive

Special tools and workshop equipment required

- ◆ Refractometer -T10007-

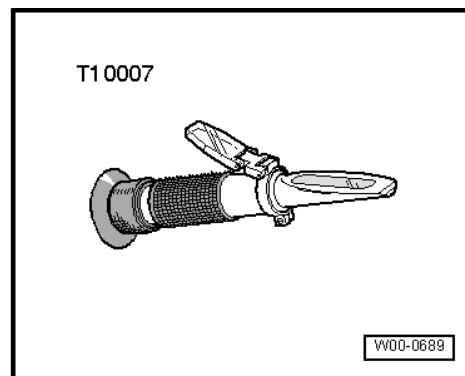

Note

Read precise value for the following tests at bright/dark boundary. Using a pipette, place a drop of water on the glass to improve the readability of the bright/dark boundary. The bright/dark boundary can be clearly recognised on the „WATERLINE“.

Perform the following jobs:

- Check concentration of coolant additive using refractometer - T10007- (note).



The scale -1- of the refractometer is calibrated for coolant additives G 11, G 12; G 12 Plus and G 12 Plus Plus.

The scale -2- is only calibrated for coolant additive G 13 (initially L80).



Note

- ◆ Frost protection must be assured to about -25 °C (in arctic climatic countries to about -35 °C).
 - ◆ If a stronger form of frost protection is required for climatic reasons, the percentage of G 12 Plus Plus can be increased.
 - ◆ But only up to 60 % (frost protection down to about -40 °C), as otherwise frost protection will be reduced again and cooling effectiveness is also reduced.
- If frost protection is insufficient, drain required quantity shown in frost protection table and add coolant additive G 12 Plus Plus.

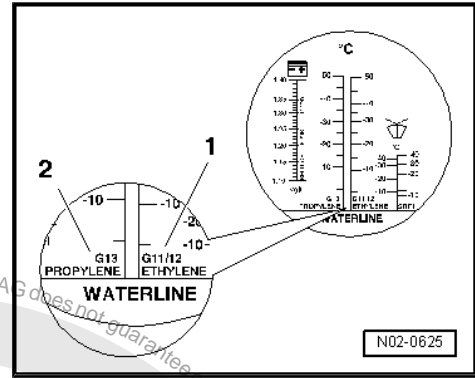

Note

Observe disposal regulations!

Frost protection to °C		Quantity to drain (in litres)
Actual value	Specified value	4-cylinder diesel engine
0	-25	3,5
	-35	4,5
-5	-25	3,0
	-35	4,0
-10	-25	2,5
	-35	3,5
-15	-25	2,0
	-35	2,5
-20	-25	1,5
	-35	2,5
-25	-35	2,0
-30	-35	1,0
-35	-40	1,0

- Check coolant additive concentration after road test again.

4.28.2 Mixing coolants

Refer to the table to glean which coolants can be mixed and which coolant can be added to the standard filling.



Note

Use distilled water to mix the coolant.



Initial filling / standard filling				
Can be mixed with ...	G11 from 1994	G12 from 1996	G12+ from 2000	G12++ from 2005
G11	X	0	0	0
G12	0	X	0	0
G12+	X 1.)	X	X	0
G12++	X 1.)	X	X	X

Key

- ◆ „X“ May be mixed
- ◆ „0“ May NOT be mixed
- ◆ 1.) Becomes discoloured after mixing (brown)

Note

If „G11“ is mixed with „G12+“ or „G12++“, the coolant will become brown in colour.

4.28.3 Checking coolant level, replenish coolant if necessary

Perform the following jobs:

- Check coolant level in expansion tank with engine cold.

Recommended coolant level at delivery inspection:

- ◆ Coolant level above „Min. marking“ -arrow-.

Recommended coolant level at inspection service

- Slightly above area -arrow-.
- If coolant is too low, add required amount according to mixture ratio.

Note

If fluid loss is greater than can be expected through normal use, determine source and rectify (repair measure).

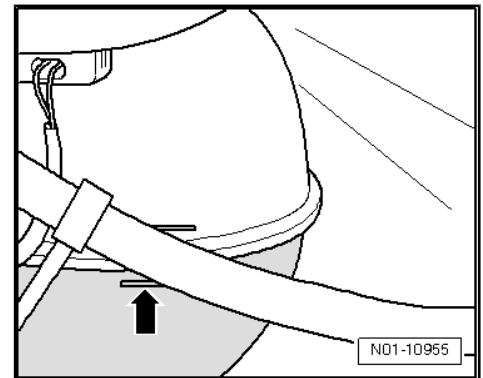

4.28.4 Mixture ratio

Frost protection to	Coolant additive G 12 Plus Plus	Water
-25 °C	approx. 40 %	approx. 60 %
-35 °C	approx. 50 %	approx. 50 %
-40 °C	approx. 60 %	approx. 40 %



Note

- ◆ *Coolant additive G 12 Plus Plus prevents frost and corrosion damage, scaling and also raises boiling point of coolant. For these reasons, the cooling system must be filled all-year-round with a coolant and corrosion protection additives.*
- ◆ *Because of its high boiling point, the coolant improves engine reliability under heavy loads, particularly in countries with tropical climates.*
- ◆ *The coolant concentration must not be reduced by adding water even in warmer seasons and in warmer countries. The antifreeze portion must be at least 40 %.*

4.29 Air filter: Clean housing and renew filter element



Note

- ◆ *When replacing air filter, make sure that no dirt gets into intake hose, air mass meter -G70- and air filter cover.*
- ◆ *Following each air filter change, programmed values of engine control unit -J623- must be reset using Guided fault finding with vehicle diagnostic, testing and information system -VAS 5051B- or vehicle diagnostic and service information system -VAS 5052 A- => [page 90](#) .*

Special tools and workshop equipment required

- ◆ Spring-type clip pliers -VAS 5024/A-

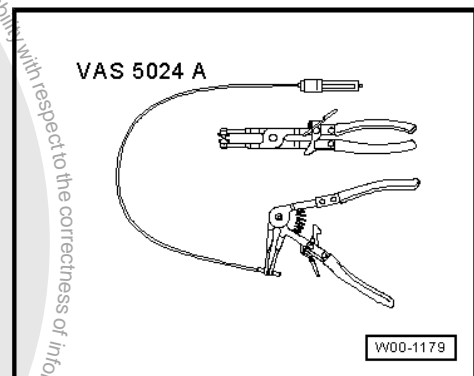

- ◆ Torque wrench -V.A.G 1783-

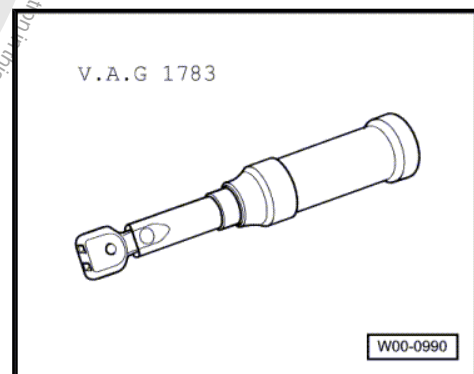



Perform the following jobs:

Removing

- Before changing air filter, clean outside of components with compressed air.
- Seal all openings of components using caps or hood covers immediately after removal.
- Pull connector -1- off intake air temperature sender -G42- and connector -2- from air mass meter -G70- .
- Remove vacuum hose -3- from air filter cover -6-
- Remove clamp -4- from intake hose -5- and pull off intake hose -5-.
- Loosen bolts -arrows- of air filter cover
- Raise air filter upper part and remove upwards.

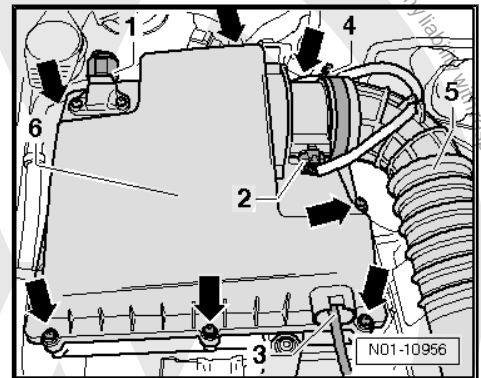

- Remove air filter element -1-.
- Clean air filter housing if necessary.

Installing

Perform the following jobs:

- Install new air filter insert -1-.
- Remove all caps or hood covers from sealed components.

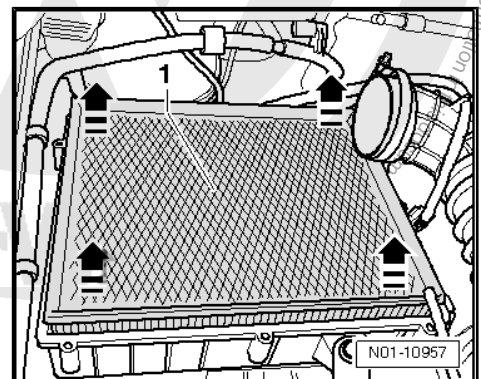

Note

When installing ensure the air filter element -1- is properly seated in housing and check if seal is seated securely and completely.



Note

When installing air filter upper part, ensure that the seal of air filter element is not moved or trapped and that both parts of housing are flush.

- Tighten bolts -arrows- of air filter cover.

Torque setting: 2 Nm.

- Push on intake hose -5- and secure clamp -4-.

Torque setting: 5.5 Nm.

- Push vacuum hose -3- onto air filter cover -6-.



- Then push connector -1- onto intake air temperature sender -G42- and connector -2- onto air mass meter -G70- .

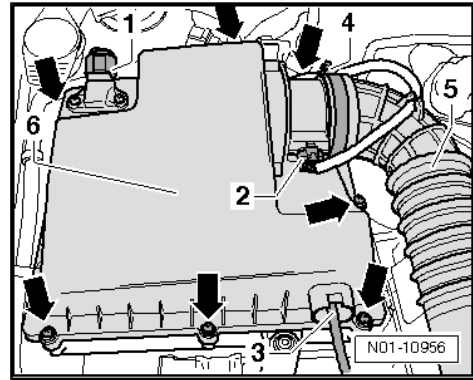

4.30 Air filter with saturation indicator in dash panel insert:



Note

When rectifying a saturated filter as a separate job, clean air filter housing and renew filter element.

Perform the following jobs:

Saturation indicator is located in dash panel insert -K- and displays contamination of filter element inc. filter housing.

- Clean air filter housing and renew filter element ⇒ [page 88](#) .
- Resetting programmed values in engine control unit -J623- got saturation indicator ⇒ [page 90](#) .

4.31 Resetting programmed values in engine control unit

Perform the following jobs:

- Connect vehicle diagnostic, testing and information system -VAS 5051B- or vehicle diagnostic and service information system -VAS 5052 A- with ignition switched off ⇒ [page 71](#) .



Note

Observe current operating instructions for vehicle diagnostic, testing and information system -VAS 5051B- or vehicle diagnostic and service information system -VAS 5052 A-, which are shown on display after selecting the functions Administration and Operating manual.

- Select „Guided fault finding“ on display of vehicle diagnostic, testing and information system -VAS 5051B- or vehicle diagnostic and service information system -VAS 5052 A- and identify vehicle.
- Select „Powertrain“, „Engine“ and then „Functions“.
- Select function „01 Reset programmed value“.
- Follow menu instructions to reset programmed values of engine control unit -J623- .
- Switch off ignition and disconnect vehicle diagnostic, testing and information system -VAS 5051B- or vehicle diagnostic and service information system -VAS 5052 A- .





4.32 Engine oil level: Check



Note

In engines with engine codes CFPA, CDBA and CDCA, it is only possible to assess and check oil level when engine is at operating temperature.

Perform the following jobs:

- After shutting off engine, wait at least 3 minutes so that the oil can flow back into the sump.
- Pull out dipstick and wipe with a clean cloth and then push dipstick in again to limit stop.
- Pull dipstick out again and read oil level.

For dipstick as illustrated:

- A - Oil must not be replenished.
- B - Oil may be replenished. It may happen that the oil level afterwards is in the -A- region.
- C - Oil must be replenished. It is sufficient if the oil level is in the -B- region (hatched area) afterwards.

There is a danger of damaging the catalytic converter if the oil level is above the -A- marking.

- If the oil level is below the -C- mark, replenish oil up to the -A- mark.

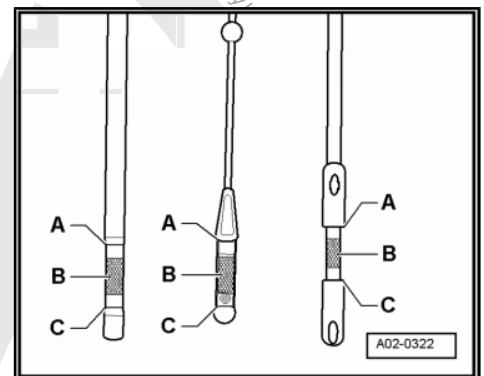

4.33 Engine oil: Drain or extract; renew oil filter and replenish engine oil

In the case of difficult operating conditions such as operation



Note

- ◆ *with fuel containing sulphur,*
- ◆ *with frequent short trips,*
- ◆ *in areas with high levels of dust,*
- ◆ *with frequent trips carrying a full load or pulling a trailer,*
- ◆ *with a high number of cold starts,*
- ◆ *and when the vehicle is used for a long time in areas with extremely low temperatures,*

the engine oil should be changed more often than indicated in the service schedule.

Furthermore extreme operating conditions for vehicles with diesel particulate filter are stop and go operation, such as in urban traffic. Use, in these conditions is an additional load on the engine oil which is taken into account by the flexible service interval system.

- Draining or extracting engine oil ⇒ [page 92](#)
- Renewing oil filter ⇒ [page 92](#) .
- Replenishing engine oil ⇒ [page 95](#) .



4.33.1 Draining or extracting engine oil



Note

For engines with standing oil filter the oil filter must be renewed before changing the engine oil. When removing the filter element a valve is opened, the oil in the filter housing automatically flows into crankcase.

Special tools and workshop equipment required

- ◆ Used oil collection and extraction unit -VAS 6622-
- ◆ Oil filter strap wrench
- ◆ Oil spill cloth -VAS 6204/1-

Draining or extracting engine oil



Note

For engines with standing oil filter the oil filter must be renewed before changing the engine oil. When removing the filter element a valve is opened, the oil in the filter housing automatically flows into crankcase.

Perform the following jobs:

- Extract engine oil using used oil collection and extraction unit -VAS 6622- .

Or

- Removing and installing skid plate ⇒ [page 133](#) .
- Remove oil drain plug.
- Let engine oil drain.



Note

The oil drain plug and seal are one unit and must be renewed together.

- Screw in oil drain plug together with seal hand-tight and then tighten to specified torque.

Specified torques for oil drain plug

- ◆ Diesel engines: 30 Nm
- ◆ Petrol engines: 30 Nm



WARNING

- ◆ *Torque specifications must not be exceeded.*
- ◆ *Excessive torque can cause leaks in the area of the oil drain plug or even damage.*

4.33.2 Renewing oil filter

- ◆ Renewing oil filter, engine with engine codes CDBA, CDCA
⇒ [page 93](#)



- ◆ Renewing oil filter, engine with engine code CFPA
⇒ [page 94](#)

4.33.3 Renewing oil filter, engine with engine codes CDBA, CDCA

Special tools and workshop equipment required

- ◆ Torque wrench -V.A.G 1331-

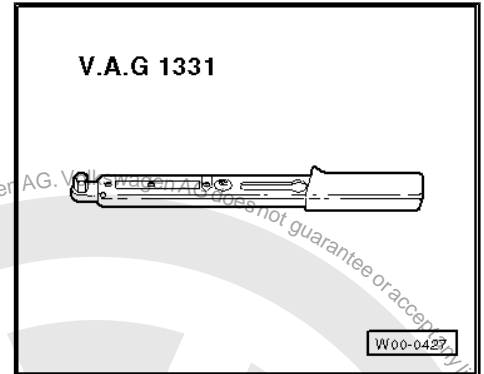

Removing

Perform the following jobs:



Note

- ◆ *Before draining or extracting release threaded cap, so that the engine oil can flow out of filter housing.*
 - ◆ *Prevent engine oil from dripping onto components in engine compartment.*
 - ◆ *Observe disposal regulations!*
 - ◆ *Oil new O-rings before installing.*
- Loosen threaded cover -1- on hexagonal flats or along perimeter and remove.
 - Clean sealing surfaces on threaded cap and oil filter housing.

Installing

Perform the following jobs:

- Renew filter element -5-.
- Renew O-rings -2-, -3- and -4-.
- Fit threaded cover -1- and tighten.

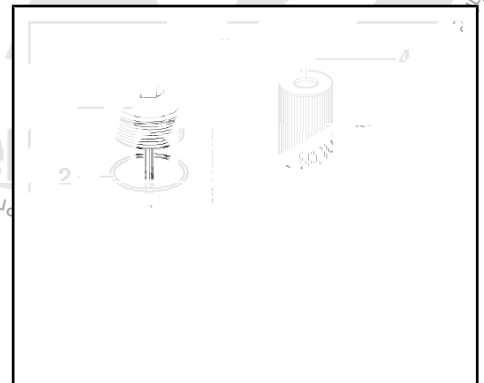

Specified torque: 25 Nm

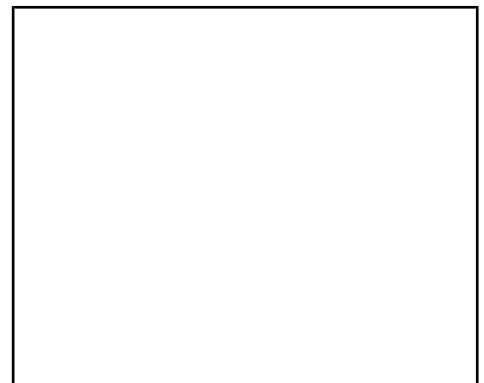



4.33.4 Renewing oil filter, engine with engine code CFPA



Note

Observe disposal regulations!

Special tools and workshop equipment required

- ◆ Torque wrench -V.A.G 1331-

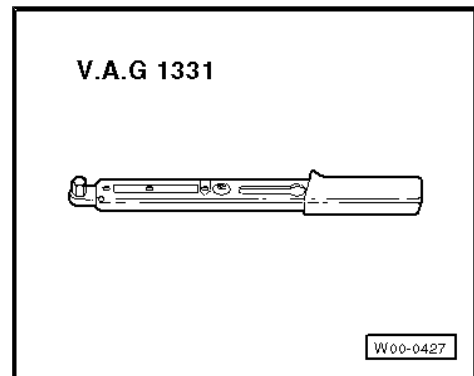

- ◆ Oil filter tool -VAS 3417-

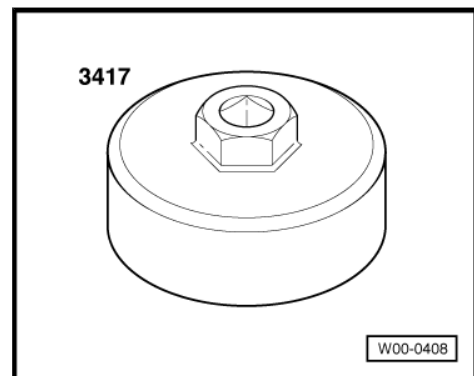

Or

- ◆ Oil filter with tensioning strap Hazet - 2171-1
- ◆ Oil spill cloth -VAS 6204/1-

Or

- ◆ Universal cloth -VAS 6385-

Removing

Perform the following jobs:

- Loosen oil filter -arrow- with oil filter tool -VAS 3417- and remove filter.
- Clean sealing surface for example with universal cloth -VAS 6385- .

Installing

Perform the following jobs:

- Oil rubber seal lightly on new oil filter.
- Screw on new filter and tighten.

Specified torque: 22 ± 2 Nm

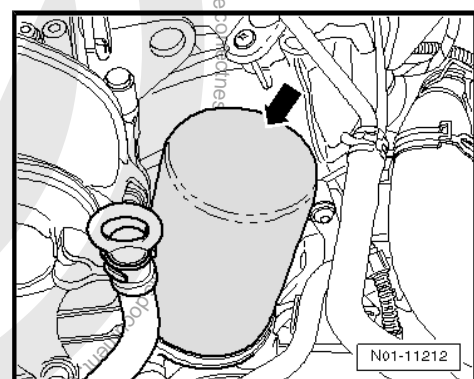



4.33.5 Replenishing engine oil

VW engine oil standards ⇒ [page 10](#)

Engine oil capacities see ⇒ Engine lubrication; Rep. gr. 17

General notes

Perform the following jobs:

- After replenishing with oil, wait at least 3 minutes and then check oil level.



Note

It is absolutely necessary to perform oil level check with the engine warm in order to ensure correct assessment of the oil level.

- Pull out dipstick, wipe with a clean cloth and push dipstick in again to limit stop.
- Pull dipstick out again and read oil level.

For dipstick as illustrated:

- A - Oil must not be replenished.
- B - Oil may be replenished. It may happen that the oil level afterwards is in the -A- region.
- C - Oil must be replenished. It is sufficient if the oil level is in the -B- region (hatched area) afterwards.

There is a danger of damaging the catalytic converter if the oil level is above the -A- marking.

- If the oil level is below the -C- mark, replenish oil up to the -A- mark.

VW engine oil standards ⇒ [page 10](#)

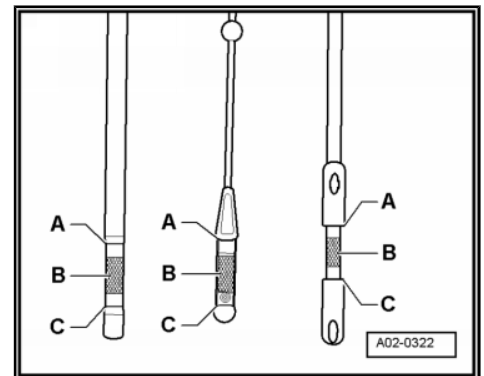

4.34 Engine and components in engine compartment (from above and below): Perform visual check for leaks and damage

Perform the following jobs:

- Check engine and components in engine compartment for leaks and damage.
- Check lines, hoses and connections of
 - ◆ Fuel system
 - ◆ Cooling and heating system
 - ◆ And brake system

for leaks, abrasions, porosity and brittleness.



Note

- ◆ *Arrange for defects to be rectified as repair measures.*
- ◆ *If fluid loss is greater than can be expected through normal use, determine source and rectify (repair measure).*



4.35 Bonnet catch: Clean, ensure attachment is secure and lubricate

Special tools and workshop equipment required

- ◆ Universal cloth -VAS 6385-

Perform the following jobs:

- Clean bonnet catch -arrow- with cleaning solution -D 009 401 04- and, for example, a universal cloth -VAS 6385-. Also use „compressed air“ to clean if necessary.

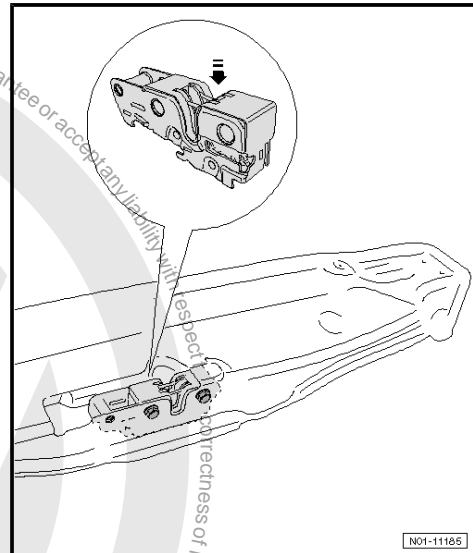

- Lubricate bonnet catch -arrow- with grease -G 000 150- .
- Ensure bonnet catch is seated securely with »back and forth« movement; retighten screws if necessary ⇒ Lids, flaps, cab, central locking; Rep. gr. 55 ; Removing and installing bonnet catch .

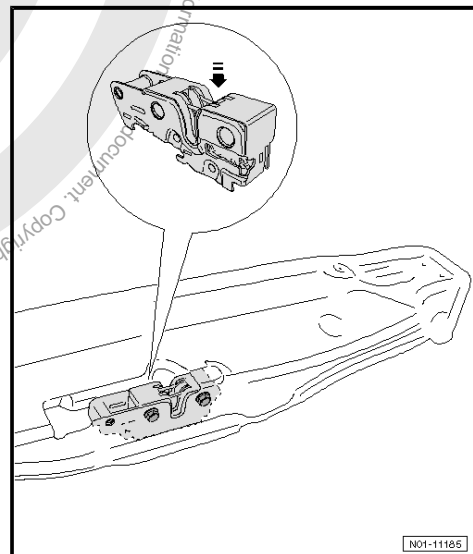

4.36 Check breakdown set

- ◆ Breakdown set location ⇒ [page 96](#)
- ◆ Check minimum use-by date ⇒ [page 97](#)

4.36.1 Breakdown set location

Model	Location
2H	In drawer under driver or front passenger seat



Note

If the breakdown set is not found at the fitting location described, this can be found in ⇒ vehicle wallet .

4.36.2 Check minimum use-by date

The breakdown set consists of the compressor and a tyre filler bottle with sealant .

Because the sealant in the tyre filler bottle has a limited expiry date, this date is indicated on the bottle -arrow-.

Perform the following jobs:

- Check the expiry date and renew the tyre filler bottle with sealant , if the expiry date is reached.

This example shows that the expiry date 05/2003. The tyre filler bottle with sealant must be renewed.

The tyre filler bottle with sealant is available as replacement part. The part number can be found in ⇒ Electronic parts catalogue „ETKA“ .



Caution

If the tyre filler bottle with sealant was opened e.g. at a "flat tyre", it must be renewed.



Note

- ◆ Residual tyre sealant or bottles which are filled and the expiry date has been exceeded, must be disposed of.
- ◆ Old tyre sealant or residual sealant must not be mixed and disposed of with other fluids.

Disposing of tyre sealant ⇒ Handbook, Service Organisation; Environment protection and disposal practice; Chapter 3 Fundamentals; Chapter. 6.5 .

4.37 Performing road test

Which of the following can be checked depends on vehicle equipment and local conditions (urban/country).

Check the following during a road test:

- Engine: Output, misfiring, idling speed, acceleration.
- Clutch: Pulling away, pedal pressure, odours.
- Gear selection: Ease of operation, stick position.
- Braking to clear brake discs: drive approx. 500 m in 2nd gear at 50 to 60 km/h. Brake slightly several times, then brake strongly 3 times. It is also possible to allow the brakes to drag for approx. 4 minutes for each vehicle axle on the single-axle roller dynamometer.
- Foot brake and handbrake: Function, free travel and effectiveness, pulling to one side, juddering, squeal.
- ABS function: Pulsing must be felt at the brake pedal during ABS-regulated braking.



- Steering: Function, steering free clearance, steering wheel centred when vehicle is travelling straight ahead
- Radio/radio navigation system: Function, reception, GALA, interference noise
- Multi-function indicator (MFI): Functions
- Air conditioning system: Function
- Vehicle: Pulling to one side when travelling straight-ahead (level road)
- Imbalance: Wheels, drive shafts, propshaft
- Wheel bearings: Noises
- Engine: Hot starting behaviour

4.38 Wheel securing bolts: Tighten to specified torque

Special tools and workshop equipment required

- ◆ Torque wrench -V.A.G 1332/- (40-200 Nm)

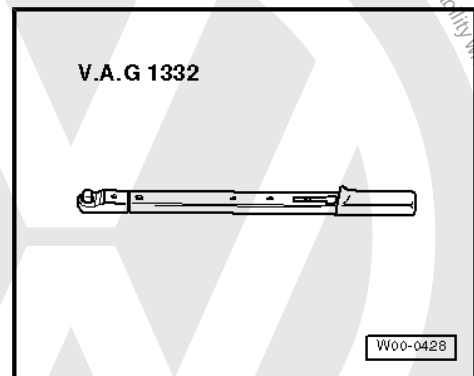

and if necessary, if anti-theft wheel bolts are installed:

- ◆ Adapter set for tamper-proof wheel bolts -T10101-

Or

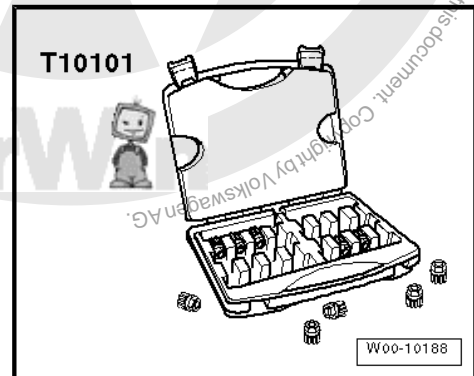

- ◆ Adapter set for tamper-proof wheel bolts -T10190-

Pulling off wheel hub trim.

The puller hook -1- to remove the cover caps is located with the vehicle tool kit.

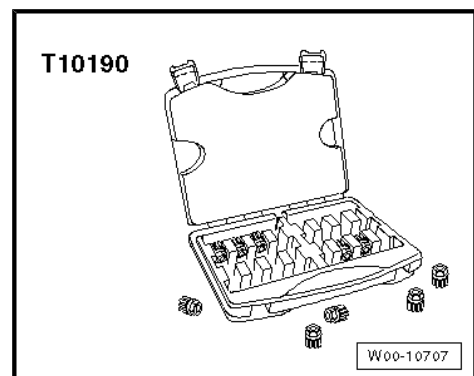



- Hook puller hook into one drilling of wheel hub trim and pull off in -direction of arrow-.

Pulling off wheel bolt caps.



Note

Before removing wheel bolts, remove the cover caps.

The puller hook to remove the cover caps is located with the vehicle tool kit.

Perform the following jobs:

- Insert wire hoop through opening in cover cap.
- Pull off cap with wire hoop.

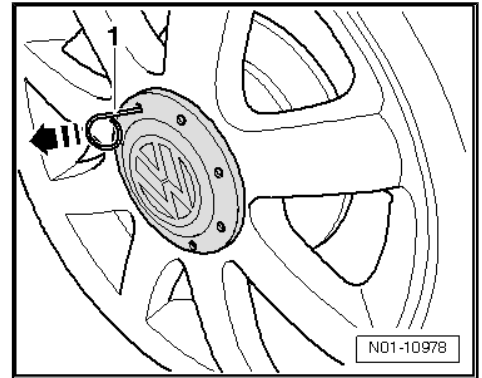

Loosening anti-theft wheel bolts.



Note

To loosen the theft-resistant wheel bolts a special adapter is required, located in vehicle tool kit or use adapter set for tamper-proof wheel bolts -T10101- or adapter set for tamper-proof wheel bolts -T10190-

- Push adapter -2- into anti-theft wheel bolt -1- onto stop.
- Push wheel brace onto adapter -2- onto stop.
- Unscrew wheel bolt by about one turn.

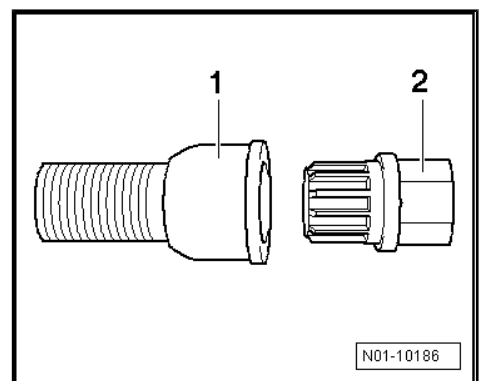

Tighten wheel bolts.



Note

Ensure that wheel bolts are tightened diagonally and alternately to the following specified torque:

Specified torque: 180 Nm

- Place puller hooks and adapter with vehicle tool kit after completing work.

4.39 Reading radio code



Note

Only valid for vehicles without sticker with serial number and radio code on vehicle data sticker.

Reading radio code using vehicle diagnostic, testing and information system -VAS 5051B- or vehicle diagnostic and service information system -VAS 5052 A-

Authorization prerequisites for reading radio code

- The vehicle diagnostic, testing and information system -VAS 5051B- or vehicle diagnostic and service information system -VAS 5052 A- is connected via the „Central Partner Network“ (CPN) with the central database (Carport, Fazit).



- Available access for the user of the system „GeKo“ (secrecy and component protection)



Note

- ◆ *The radio codes are read in the central database (Carport, Fazit) and are indicated on display of vehicle diagnostic, testing and information system -VAS 5051B- or vehicle diagnostic and service information system -VAS 5052 A- .*
- ◆ *To activate the anti-theft coding the radio code must be entered using radio buttons, as previously ⇒ [page 101](#) .*

Perform the following jobs:

- Connect vehicle diagnostic, testing and information system -VAS 5051B- or vehicle diagnostic and service information system -VAS 5052 A- with ignition switched off ⇒ [page 71](#) .
- Switch on ignition.
- Press the **Guided functions** button on display of vehicle diagnostic, testing and information system -VAS 5051B- or vehicle diagnostic and service information system -VAS 5052 A- .
- Press **[]** button to confirm selection.
- Then perform vehicle identification on vehicle diagnostic, testing and information system -VAS 5051B- or vehicle diagnostic and service information system -VAS 5052 A- .
- Select one after another:
 - ◆ Brand
 - ◆ Type
 - ◆ Model year
 - ◆ Version
 - ◆ Engine code
- If the vehicle identification has been performed correctly, confirm with **[]** button.
- Select one after another:
 - ◆ Radio system
 - ◆ Reading radio code
- Follow instructions of vehicle diagnostic, testing and information system -VAS 5051B- or vehicle diagnostic and service information system -VAS 5052 A- to read the radio code according to „Guided functions“.

Exit radio code reading as follows:

- Select function **GoTo** on display.
- Press function **End** on display.
- Select function **End** in „End menu“.
- Switch off ignition and separate diagnosis connection from vehicle.



Note

Inform the customer about the radio code.

Reading radio code using „ElsaWin“ (Electronic Service Information System) and Vehicle Individual Service Notes „FISH“

Reading the radio code was integrated with „ElsaWin“ (Electronic Service Information System) version 3.0 into Vehicle Individual Service Notes „FISH“. Currently this function is only valid for Volkswagen and Commercial vehicles.



Note

- ◆ *Radio codes cannot be read in „FISH“ with the previous access authorization for radio codes. Reading only functions with the access authorization for „GeKo“ (secrecy and component protection).*
- ◆ *The access authorization for „GeKo“ (secrecy and component protection) for reading the radio code using vehicle diagnostic, testing and information system -VAS 5051B- or vehicle diagnostic and service information system -VAS 5052 A- is also valid for reading the radio code in Vehicle Individual Service Notes „FISH“.*

Authorization prerequisites for reading radio code

- Available access for the user of the system „GeKo“ (secrecy and component protection)

Perform the following jobs:

- Follow the instructions of Vehicle Individual Service Notes „FISH“ in Electronic Service Information System „ElsaWin“.



Note

- ◆ *To read the radio code the radio serial number must be entered fully. This can be entered using vehicle diagnostic, testing and information system -VAS 5051B- or vehicle diagnostic and service information system -VAS 5052 A- via „Guided functions“ and „Measured value block 81“. For this follow instructions of vehicle diagnostic, testing and information system -VAS 5051B- or vehicle diagnostic and service information system -VAS 5052 A-.*
- ◆ *To enter the radio serial number the 17-digit chassis number is taken from the order.*
- ◆ *If you are authorized to read the radio code via „GeKo“ (secrecy and component protection), you will obtain the 4-digit radio code to the radio serial number.*



Note

Inform the customer about the radio code.

4.40 Radio / radio navigation system: Enter anti-theft coding PIN

The anti-theft coding electronically prevents unauthorized persons from operating the unit after it has been removed from vehicle. The anti-theft codes are also called radio codes or se-



curity codes. Security code means that each unit with an anti-theft coding is programmed with its own code number. This security code is not active when leaving the factory. The security code is found on the unit card, if fitted. If the unit card is not fitted, the security code can be read from a central database using vehicle diagnosis tester.



Note

If an incorrect code number is entered when releasing the electronic lock, the whole procedure can be repeated once. If an incorrect code number is entered again, the unit is locked for about one hour. That means, it cannot be used. After one hour, during which time the unit must remain switched on, the display extinguishes. The electronic lock can be released as described above. The cycle, two attempts, one hour lock, applies again.

Procedure

Deactivating anti-theft coding ⇒ Infotainment; Rep. gr. 91 .

4.41 Radio navigation system: Insert navigation CD/DVD and perform update

If no navigation CD/DVD is inserted in the CD/DVD slot, after entering the radio code it can be displayed that no navigation CD/DVD is inserted.

In this case, insert the navigation CD/DVD according to ⇒ Operating instructions .



Note

When the navigation CD is inserted the first time, the radio navigation system performs an update, which can take up to 5 minutes. Do not pull off ignition switch and radio navigation system during this process, because the radio navigation system then switches off and the update will be interrupted!

4.42 Timing chain: Renew

– The procedure is described in workshop manual ⇒ Rep. gr. 15 .

4.43 Windscreen wash/wipe system and headlight washer system: Check function and settings

- ◆ Check antifreeze content of Windscreen Clear with G 052 164, replenish with fluid if necessary ⇒ [page 102](#)
- ◆ Window wash/wipe system: Check spray jet settings and adjust if necessary ⇒ [page 104](#)

4.43.1 Checking Windscreen Clear with anti-freeze for windscreen wash/wipe system, replenish with fluid if necessary

Checking antifreeze concentration .

Special tools and workshop equipment required





◆ Refractometer -T10007-

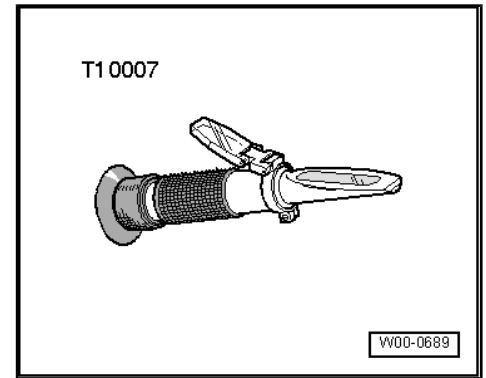

Read precise value for the following tests at bright/dark boundary. Using a pipette, place a drop of water on the glass to improve the readability of the bright/dark boundary. The bright/dark boundary can be clearly recognised on the „WATERLINE“.

Perform the following jobs:

- Check concentration of antifreeze additive using refractometer -T10007- (note).





The scale -1- of the refractometer is calibrated for Genuine Volkswagen Windscreen Clear with antifreeze G 052 164.

The scale -2- is designed for commercially available windscreen cleanser as well as a mixture of commercially available windscreen cleanser and genuine Volkswagen Windscreen Clear with antifreeze G 052 164.

Mixture ratio

Frost protection to	Windscreen Clear with antifreeze G 052 164	Water
-17/-18 °C	1 part	3 parts
-22/-23 °C	1 part	2 parts
-37/-38 °C	1 part	1 part

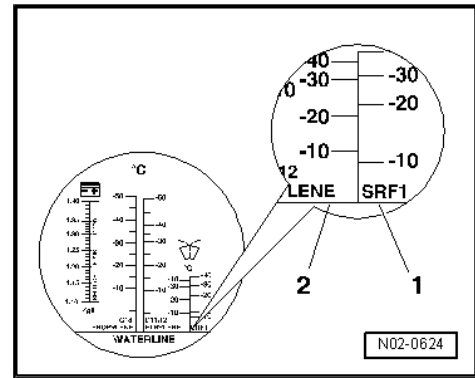

Replenishing with fluid.

The fluid reservoir of the window washer system must be filled completely.

Starting immediately, use only Genuine Volkswagen Windscreen Clear with antifreeze G 052 164 all-year-round when replenishing window wash/wipe system.



Note

- ◆ On vehicles with fan-type spray jets, the reservoir must be filled with Windscreen Clear with antifreeze G 052 164, as this fluid has a low viscosity at temperatures below freezing. Otherwise the complicated spray jet system can become blocked by the crystallised washer fluid, which affects the spray pattern of the spray jet. Windscreen Clear with antifreeze G 052 164 ensures that the fan-type spray jets remain fully functional even at low temperatures.
- ◆ Genuine Volkswagen Windscreen Clear with antifreeze G 052 164 protects the spray jets, fluid reservoir and connecting hoses from freezing.
- ◆ Also use Genuine Volkswagen Windscreen Clear with antifreeze G 052 164 in the warmer periods of the year. The powerful cleanser removes wax and oil residue from the glass.
- ◆ Frost protection must be guaranteed to approx. -25 °C (approx. -35 °C in countries with an arctic climate) in the windscreen wash/wipe system.

4.43.2 Window wash/wipe system: Check spray jet settings and adjust if necessary

Special tools and workshop equipment required

- ◆ Commercially available Torx screwdriver „T 10“



Note

The spray jets may be cleaned in both directions, also opposite to direction of spray with compressed air or water.



Windscreen spray jet settings:

The washer jets are preset. However, small height differences can be compensated for.

Perform the following jobs:

- If spray field is not at correct height, adjust spray direction upwards or downwards as follows:
- Adjust spray jet by turning with a commercially available Torx screwdriver „T10“ at adjuster -1-.

- ◆ „Clockwise“ lower.
- ◆ „Anti-clockwise“ higher.

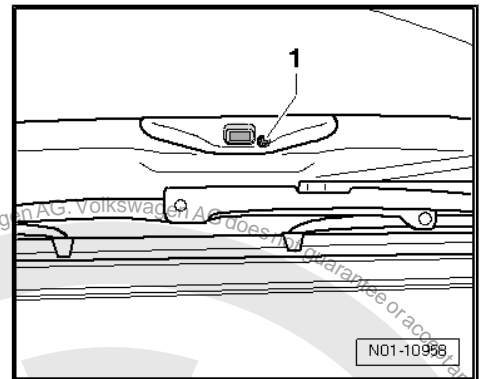
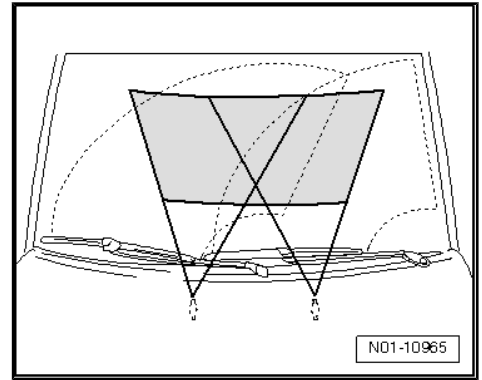

4.44 Windscreen wiper blades: Check park position

- ◆ Windscreen wiper blades: Check park position ⇒ [page 105](#) .

4.44.1 Windscreen wiper blades: Check park position

Windscreen of LHD vehicles



Note

For RHD vehicles the wiper blades are aligned as a mirror image.

Driver side

Perform the following jobs:

- Check park position.

Wiper blade tips should be located at marked position -arrow- on windscreen.

- Adjust park position by moving wiper arm if necessary.

Adjusting windscreen wiper blades ⇒ Electrical system; Rep. gr. 92 ; Windscreen wiper blades - park position .

Front passenger side

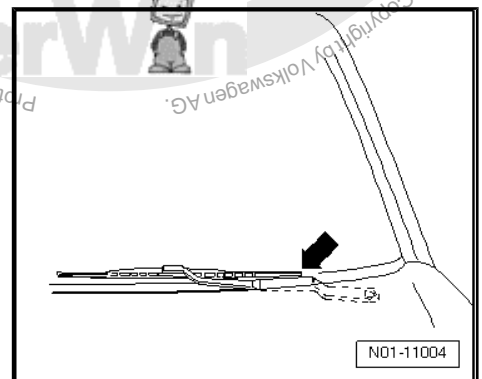



Wiper blade tips should be located at marked position -arrow- on windscreen.

- Adjust park position by moving wiper arm if necessary.
- Switch windscreen wiper on and off and let it move into park position.
- Switch off ignition.

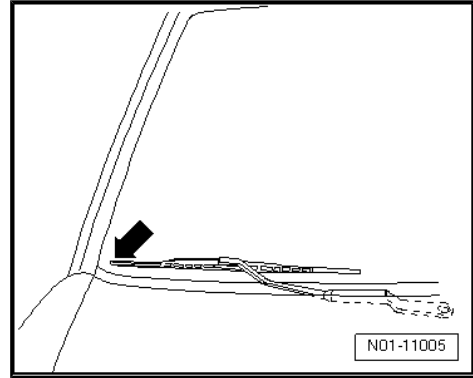

4.45 Headlight adjustment: Check, if necessary adjust

- ◆ Adjusting halogen headlights ⇒ [page 108](#) .
- ◆ Adjusting fog lights and other additional lights ⇒ [page 109](#) .
- ◆ Test prerequisites ⇒ [page 106](#)
- ◆ Checking headlight adjustment (using new test screen without 15° setting line) ⇒ [page 107](#)

4.45.1 Test prerequisites

Special tools and workshop equipment required

- ◆ Headlight adjustment unit -VAS 5046-

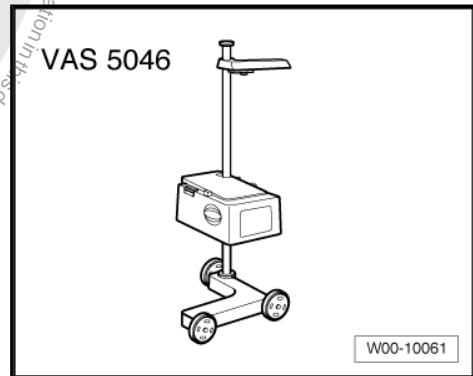

Or

- ◆ Headlight adjustment unit -VAS 5047-

Test and adjustment conditions

- ◆ Tyre pressure OK
- ◆ Lenses must not be damaged or dirty.
- ◆ Reflectors and bulbs OK
- ◆ Vehicle must be loaded.

Loading: With one person or 75 kg on the driver seat and the vehicle otherwise unloaded (unladen weight).

The unladen weight is the weight of vehicle ready for operation with a full fuel tank (at least 90 %) including weight of all equipment normally carried (e.g. spare wheel, tools, jack, fire extinguisher etc.).

If the fuel tank is not at least 90 % full, then load as follows:



Perform the following jobs:

- Read fuel level in fuel tank on fuel gauge. Determine additional weight from following table and place weight in luggage compartment.

Fuel gauge table

Fuel level of fuel gauge	Additional weight in kg
1/4	30
1/2	20
3/4	10
Full	0

Example:

When the fuel tank is half full, an additional weight of 20 kg must be placed in the luggage compartment.



Note

- ◆ *A fuel can filled with water is the best way of adding additional weight.*
- ◆ *A fuel can filled with 5 litres of water weighs approx. 5 kg.*

The vehicle must be rolled forward or backward several metres or front and rear springs must be bounced fully several times so that springs settle.

- ◆ Vehicle and headlight adjuster must be on a level surface ⇒ of headlight adjustment unit -VAS 5046- or ⇒ of headlight adjustment unit -VAS 5047-
- ◆ Vehicle and headlight adjuster must be aligned.
- ◆ Inclination must be set.

Inclination information in „%“ is stamped into trim above headlight. Headlights must be adjusted according to this information. Percentage given is based on a projection distance of 10 metres. For example: inclination of 1.0 % converts to approx. 10 cm.

Vehicles with manually regulated headlight range control

- ◆ Headlight range control thumb wheel must be in basic setting -0-.

4.45.2 Checking headlight adjustment (using new test screen without 15° setting line)

Headlights

Perform the following jobs:

- ◆ Whether, with the dipped beam switched on, the horizontal bright/dark boundary touches the dividing line -1- of the test area
- ◆ Whether the breaking point -2- between the horizontal part of the bright/dark boundary on the left and the rising part on the right lies on the vertical line of the central point -3-.



The bright core of the light beam must be to the right of the vertical line.



Note

- ◆ To simplify determination of the breaking point -2-, cover and uncover left (from driver perspective) half of the headlight a few times. Then check dipped beam again.
- ◆ After correct adjustment of dipped beams, the centre point of the main beam must lie on the centre mark -3-.
- ◆ For the previous test screens with 15° setting line, adjust as for new test screen. To avoid incorrect settings, ignore the 15° setting line.

Fog lights

- Check whether the upper light-dark border touches the setting line and runs horizontally over the entire width of the test screen.

Other additional lights

Additionally retrofitted lights of other systems must be checked and set according to valid guidelines.

4.45.3 Adjusting halogen headlights

Left headlight

Perform the following jobs:

- Check headlight setting and adjust headlights if necessary.

The adjustment bolts for the right headlight are a mirror image.

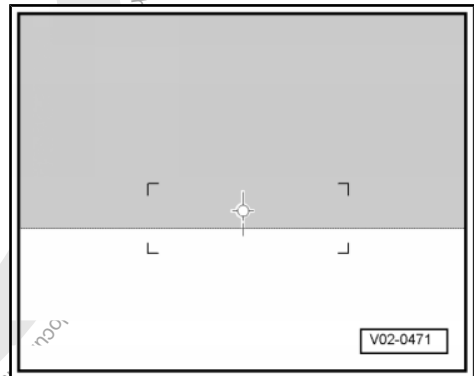
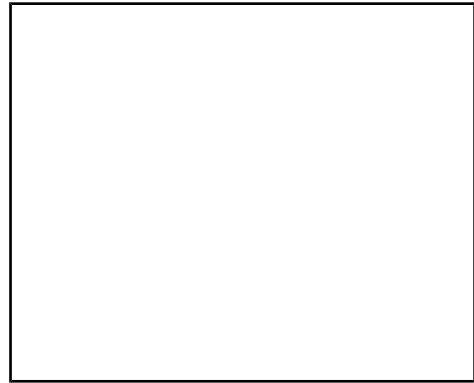



- ◆ Height adjustment bolt -1-
- ◆ Height/lateral adjustment bolt -2-
- For height adjustment, turn adjustment screws -1- and -2- with same number of turns.
- For lateral adjustment, only turn adjuster screw -2-.

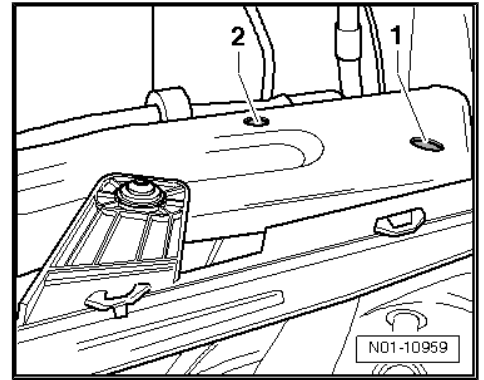

4.45.4 Adjusting fog lights and other additional lights

Fog light on left in bumper

Location of adjustment screw on right fog light is a mirror image.

Inclination:

- ◆ Fog lights 20 cm

Adjustment screw for setting fog lights can only be accessed from rear.

Perform the following jobs:

- Move adjustment screw -arrow- to regulate headlight range.

A lateral adjustment is not possible.

Other additional lights

Additionally retrofitted lights of other systems must be checked and set according to valid guidelines.

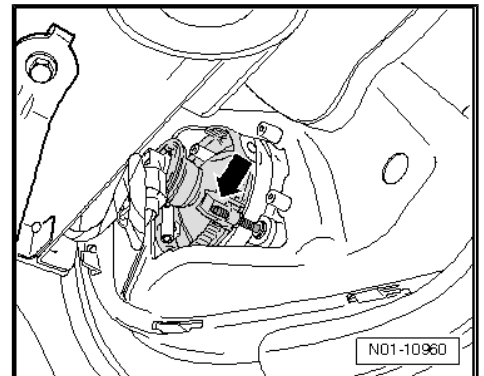

4.46 Service interval display: Reset

Using vehicle diagnostic, testing and information system -VAS 5051B- or vehicle diagnostic and service information system -VAS 5052 A-



Note

The procedure to reset the service interval display without vehicle diagnostic, testing and information system -VAS 5051B- or vehicle diagnostic and service information system -VAS 5052 A- is described in ⇒ Booklet „Controls and Equipment“ in the vehicle literature.

Service interval display must be reset (adapted) in the handover inspection and during each service!

Perform the following jobs:

- Connect vehicle diagnostic, testing and information system -VAS 5051B- or vehicle diagnostic and service information system -VAS 5052 A- ⇒ [page 71](#) .



Note

Observe current operating instructions for vehicle diagnostic, testing and information system -VAS 5051B- or vehicle diagnostic and service information system -VAS 5052 A-, which are shown on display after selecting the functions Administration and Operating manual.

Perform the following jobs:

- Switch on ignition.
- Touch the Guided functions field on the screen.
- Then perform vehicle identification on vehicle diagnostic, testing and information system -VAS 5051B- or vehicle diagnostic and service information system -VAS 5052 A- .
- Select one after another:
 - ◆ Brand
 - ◆ Type
 - ◆ Model year
 - ◆ Version
 - ◆ Engine code
- Confirm vehicle identification.
- If the vehicle identification has been performed correctly, confirm with  button.
- Select one after another:
 - ◆ „Dash panel insert“ -ARROW-
 - ◆ „Resetting the service interval display“

Perform the following jobs:

- Perform adaptation according to the information of „Guided functions“

End adaptation.

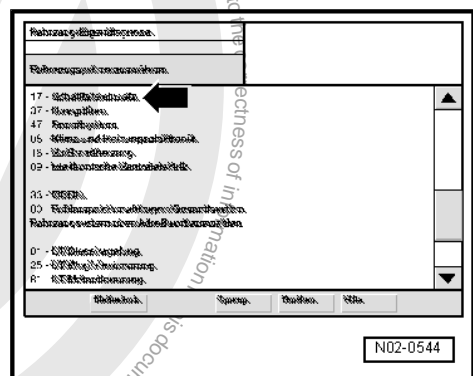
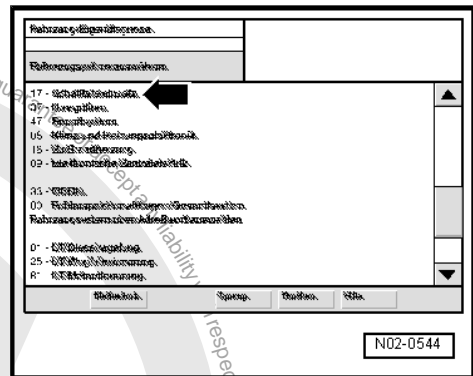



Indicated on display:

- Select function **GoTo** -arrow- on display.

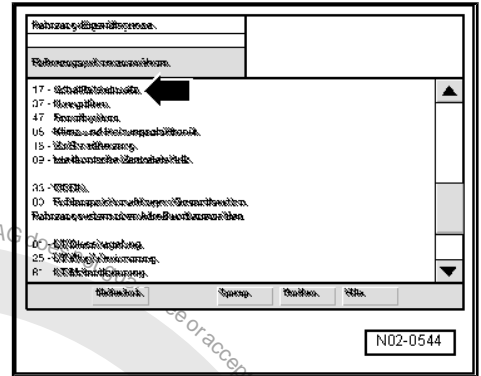

Indicated on display:

- Touch function **End** -arrow- on display.
- Select function **End** in „End menu“.
- Switch off ignition and separate diagnosis connections.
- Switch on ignition.

After the ignition is switched on, the type of service is no longer displayed in the distance display in the dash panel insert.

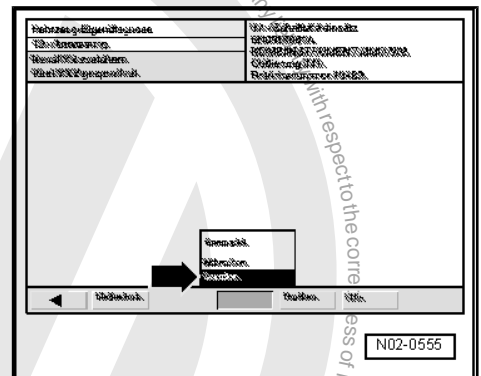

4.47 Service interval display: Recode (adapt)

Perform the following jobs:

- Connect vehicle diagnostic, testing and information system - VAS 5051B- or vehicle diagnostic and service information system -VAS 5052 A- → [page 71](#).



Note

Observe current operating instructions for vehicle diagnostic, testing and information system -VAS 5051B- or vehicle diagnostic and service information system -VAS 5052 A-, which are shown on display after selecting the functions **Administration** and **Operating manual**.

- Switch on ignition.
- Touch the **Guided functions** field on the screen.
- Then perform vehicle identification on vehicle diagnostic, testing and information system -VAS 5051B- or vehicle diagnostic and service information system -VAS 5052 A- .
- Select one after another:
 - ◆ Brand
 - ◆ Type
 - ◆ Model year
 - ◆ Version
 - ◆ Engine code
- Confirm vehicle identification.
- If the vehicle identification has been performed correctly, confirm with **>** button.



- Select one after another:
- ◆ „Dash panel insert“ -arrow-
- ◆ „Adapting service interval extension“.
- Perform adaptation according to the information of „Guided functions“.

Ending adaptation.

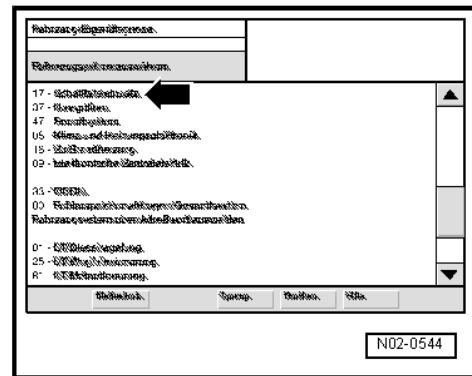

Indicated on display:

- Select function **GoTo** -arrow- on display.

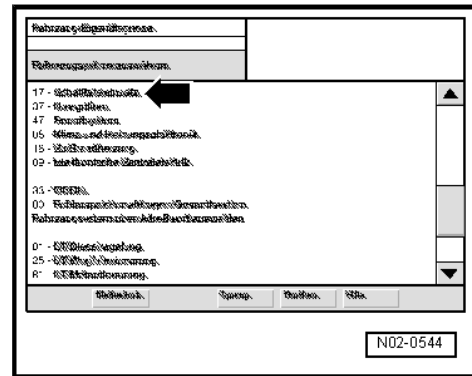

Indicated on display:

- Touch function **End** -arrow- on display.
- Select function **End** in „End menu“.
- Switch off ignition and separate diagnosis connections.
- Switch on ignition.

After the ignition is switched on, the type of service is no longer displayed in the distance display in the dash panel insert.

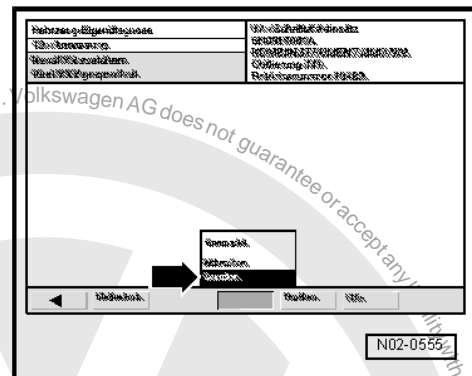

4.48 Service interval: Adjusting (inland)

Code control unit in dash panel insert -J285- in dash panel insert -K- to 5,000 km, 7,500 km or 10,000 km.

Special tools and workshop equipment required

- ◆ Vehicle diagnostic, testing and information system -VAS 5051B- or subsequent units

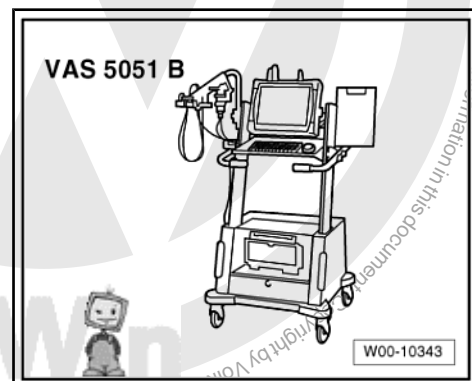

- ◆ Diagnosis cable 5m -VAS 5051B/1-



Or

- ◆ Diagnosis cable -VAS 5051/5A-

Or

- ◆ Vehicle diagnostic and service information system -VAS 5052 A-

- ◆ Diagnosis cable, 2 m -VAS 5052/3 A-

Or

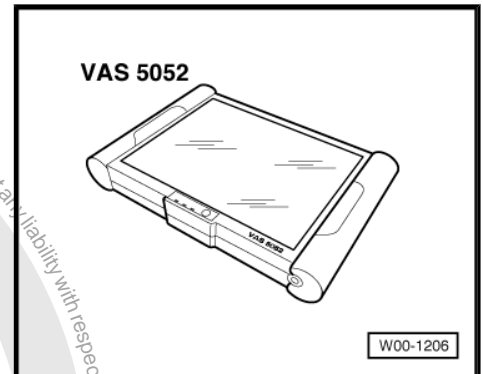

- ◆ Diagnosis cable, 5 m -VAS 5052/3 A-1-

- ◆ Battery charger -VAS 5903-

Or

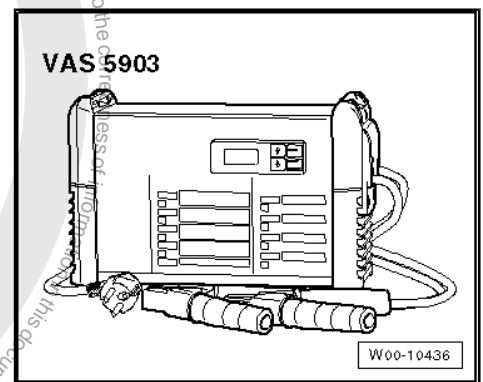



◆ Battery charger, 60A -VAS 5904-

Perform the following jobs:

- Connect vehicle diagnostic, testing and information system - VAS 5051B- or vehicle diagnostic and service information system -VAS 5052 A- ⇒ [page 71](#) .

 **Note**

Observe current operating instructions for vehicle diagnostic, testing and information system -VAS 5051B- or vehicle diagnostic and service information system -VAS 5052 A-, which are shown on display after selecting the functions Administration and Operating manual.

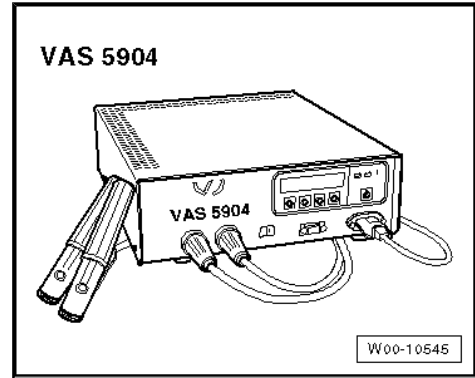

- Switch on ignition.
- Touch the Guided functions field on the screen.
- Then perform vehicle identification on vehicle diagnostic, testing and information system -VAS 5051B- or vehicle diagnostic and service information system -VAS 5052 A- .
- Select one after another:
 - ◆ Brand
 - ◆ Type
 - ◆ Model year
 - ◆ Version
 - ◆ Engine code
- Confirm vehicle identification.
- If the vehicle identification has been performed correctly, confirm with  button.
- Select one after another:
- Select „17 - Dash panel insert“ -arrow-

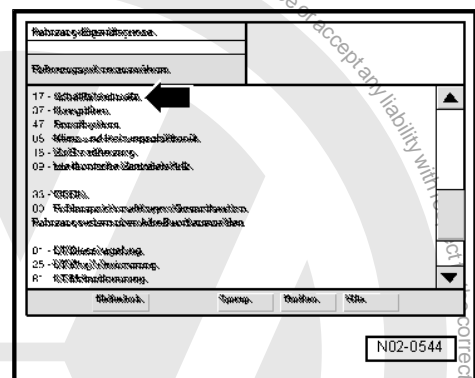

Protected by copyright. Copying for private or commercial purposes, in part or in whole, is not permitted unless authorised by Volkswagen AG. Volkswagen AG does not guarantee or accept any liability with respect to the correctness of information in this document. Copyright by Volkswagen AG.



- Select „17 - Adapt service interval“ -arrow-



Note

- ◆ *With this function, the service interval display is adapted for vehicles without LongLife service (production control number „QG0/G1“.*
- ◆ *If this function is performed on vehicles with LongLife service, the extended service interval (ESI) is deactivated.*

- Press button -arrow-
- If necessary, connect battery charger -VAS 5903- or battery charger, 60A -VAS 5904- .

- Press „Done“ button -arrow-

- Select service with „1 - Delivery inspection“ => [page 115](#) -arrow- or „2 - Other service work“ => [page 116](#) button.

„1“ Delivery inspection

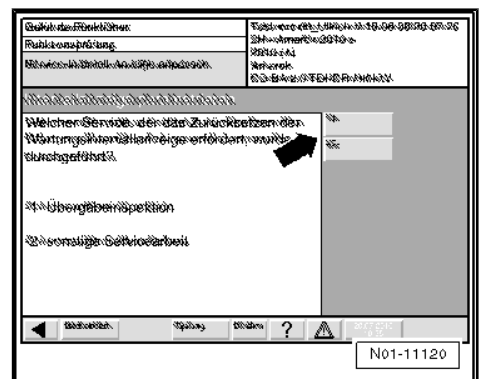
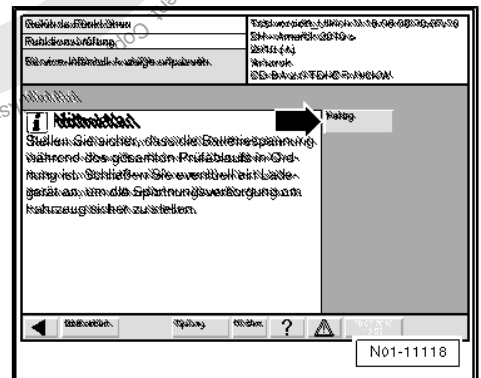
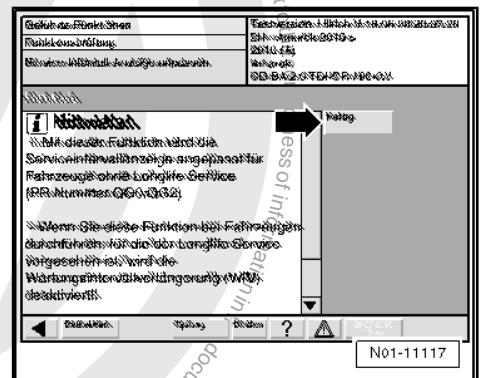
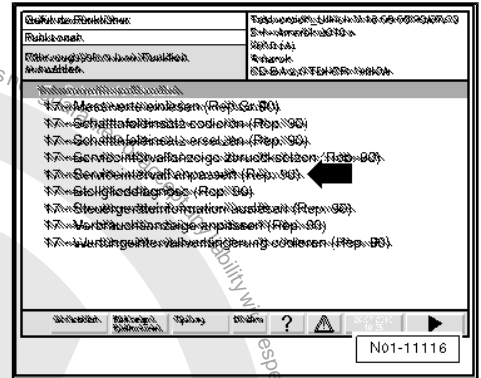



- Confirm vehicle market query with „Yes“ or „No“ -arrow-.



Note

Keep confirming the vehicle market query with „Yes“ or „No“ until the desired country appears on the display.

Confirm end of „Adapt interval“ routine with „Done“ button -arrow-.

Exit „Guided functions“.

Switch off ignition.

Remove vehicle diagnosis, testing and information system - VAS 5051B- or vehicle diagnosis and service information system -VAS 5052 A- from vehicle.

2 Other service work

- Select „km“ in next window with -1 to 4- button.
- The chosen setting is adopted by pressing the -Yes- button -arrow-.
- The service selection window is activated again by pressing the -No- button -arrow-.

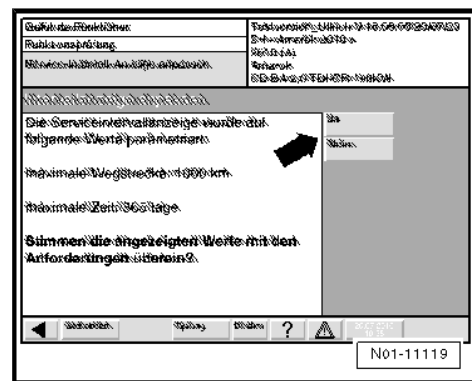
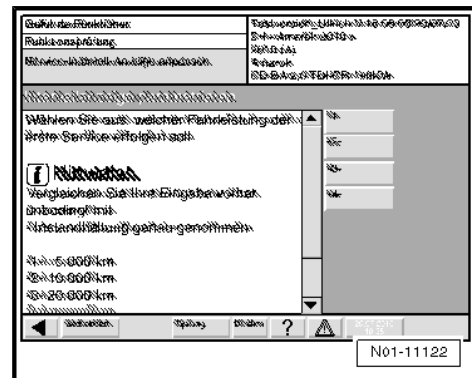
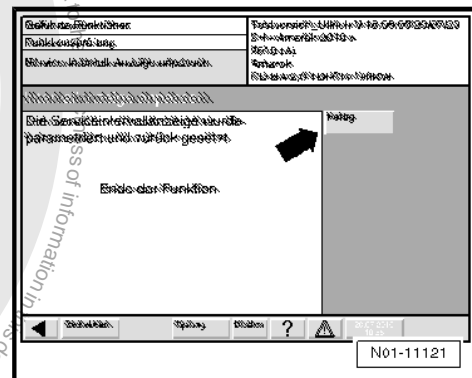
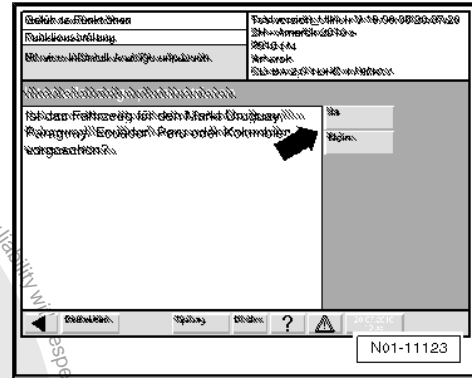



- Confirm end of „Adapt interval“ routine with „Done“ button -arrow-.
- Exit „Guided functions“.
- Switch off ignition.
- Remove vehicle diagnosis, testing and information system - VAS 5051B- or vehicle diagnosis and service information system -VAS 5052 A- from vehicle.

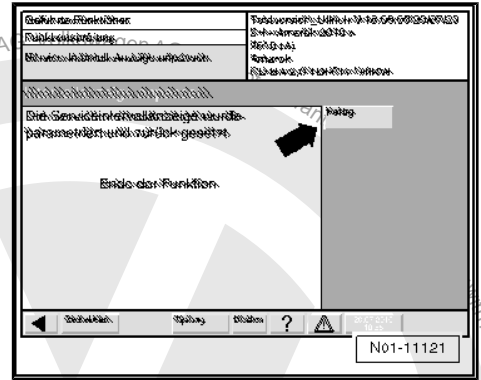

4.49 Service interval: Adjusting (export)

Code control unit in dash panel insert -J285- in dash panel insert -K- to 5,000 km, 7,500 km or 10,000 km.

Caution

◆ *Diesel engines: In some regions/countries, an elevated sulphur content may be evident in the diesel fuel. This leads to increased wear of the cylinders and impairs piston cleanliness considerably. Short service intervals therefore apply in this instance ⇒ [page 6](#).*

Special tools and workshop equipment required

- ◆ Vehicle diagnostic, testing and information system -VAS 5051B- or subsequent units

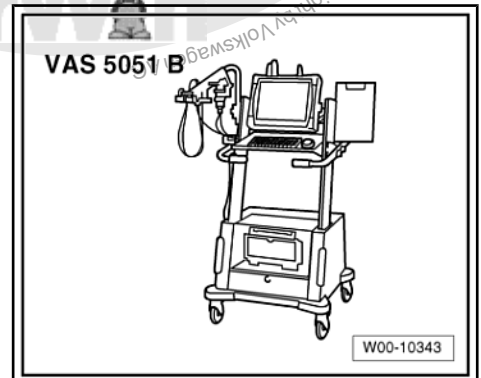

- ◆ Diagnosis cable 5m -VAS 5051B/1-

Or

- ◆ Diagnosis cable -VAS 5051/5A-

Or

- ◆ Vehicle diagnostic and service information system -VAS 5052 A-

- ◆ Diagnosis cable, 2 m -VAS 5052/3 A-

Or

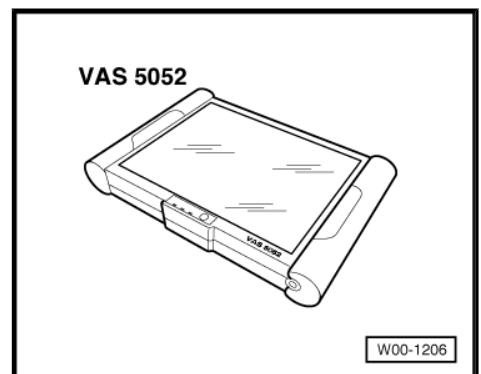



- ◆ Diagnosis cable, 5 m -VAS 5052/3 A-1-
- ◆ Battery charger -VAS 5903-

Or

- ◆ Battery charger, 60A -VAS 5904-

Perform the following jobs:

- Connect vehicle diagnostic, testing and information system - VAS 5051B- or vehicle diagnostic and service information system -VAS 5052 A- ⇒ [page 71](#) .



Note

*Observe current operating instructions for vehicle diagnostic, testing and information system -VAS 5051B- or vehicle diagnostic and service information system -VAS 5052 A-, which are shown on display after selecting the functions **Administration** and **Operating manual**.*

- Switch on ignition.
- Touch the **Guided functions** field on the screen.
- Then perform vehicle identification on vehicle diagnostic, testing and information system -VAS 5051B- or vehicle diagnostic and service information system -VAS 5052 A- .
- Select one after another:
 - ◆ Brand
 - ◆ Type
 - ◆ Model year
 - ◆ Version
 - ◆ Engine code
- Confirm vehicle identification.
- If the vehicle identification has been performed correctly, confirm with **OK** button.
- Select one after another:

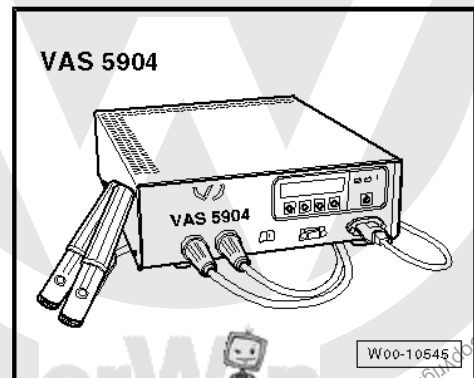
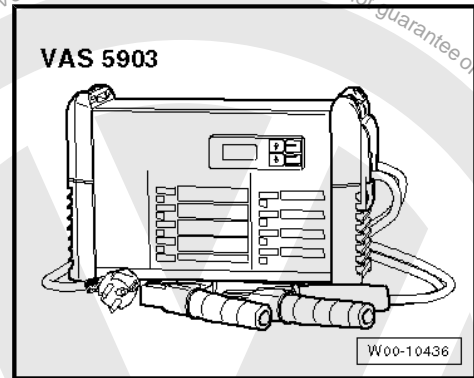



- Select „17 - Dash panel insert“ -arrow-

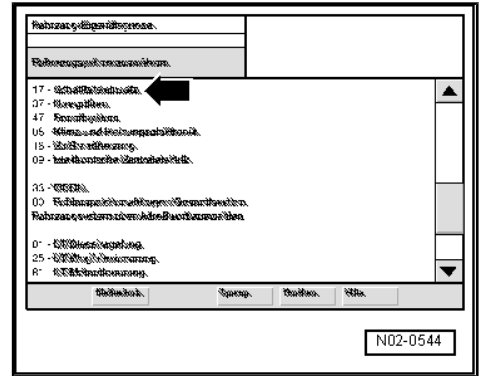

- Select „17 - Adapt service interval“ -arrow-



Note

- ◆ *With this function, the service interval display is adapted for vehicles without LongLife service (production control number „QG0/G1“.*
- ◆ *If this function is performed on vehicles with LongLife service, the extended service interval (ESI) is deactivated.*

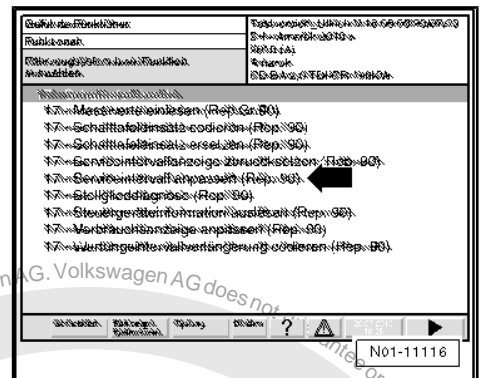

- Press button -arrow-.

- If necessary, connect battery charger -VAS 5903- or battery charger, 60A -VAS 5904- .

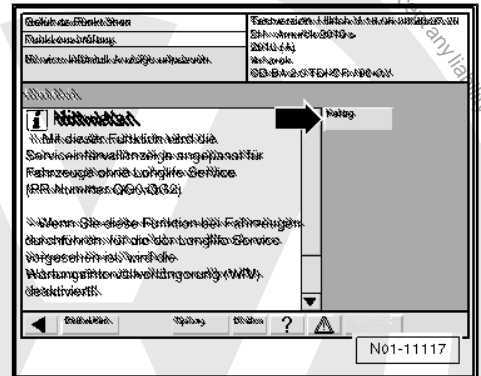

- Press „Done“ button -arrow-.

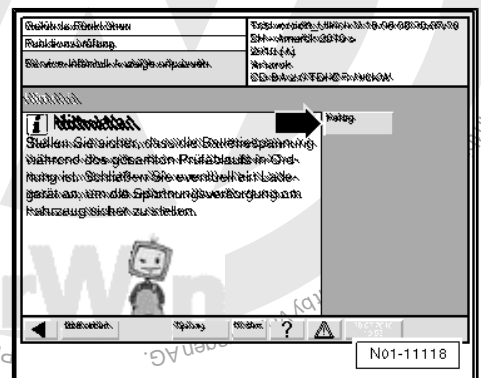



- Select service with „1 - Delivery inspection“ ⇒ [page 120](#) -arrow- or „2 - Other service work“ ⇒ [page 120](#) button.

„1“ Delivery inspection

- Confirm vehicle market query with „Yes“ or „No“ -arrow-.



Note

Keep confirming the vehicle market query with „Yes“ or „No“ until the desired country appears on the display.

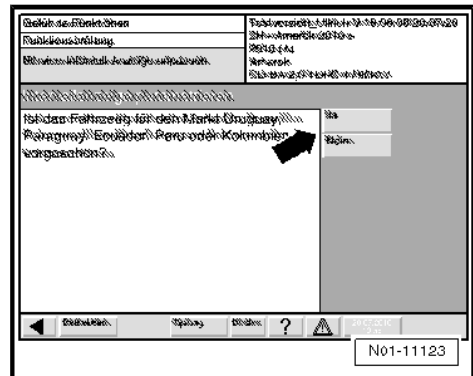
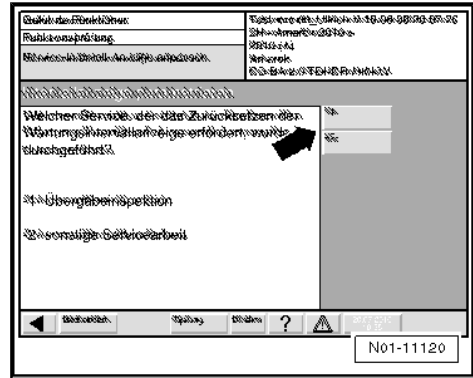

- Confirm end of „Adapt interval“ routine with „Done“ button -arrow-.
- Exit „Guided functions“ .
- Switch off ignition.
- Remove vehicle diagnosis, testing and information system - VAS 5051B- or vehicle diagnosis and service information system -VAS 5052 A- from vehicle.

„2“ Other service work

- Select „km“ in next window with -1 to 4- button.
- The chosen setting is adopted by pressing the -Yes- button -arrow-.

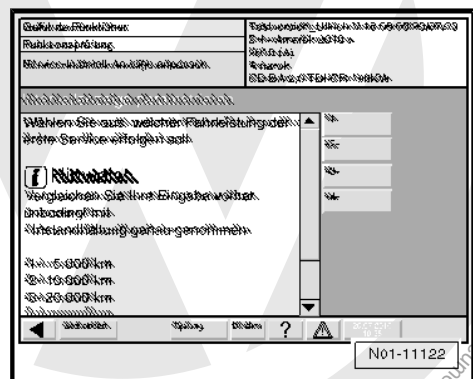
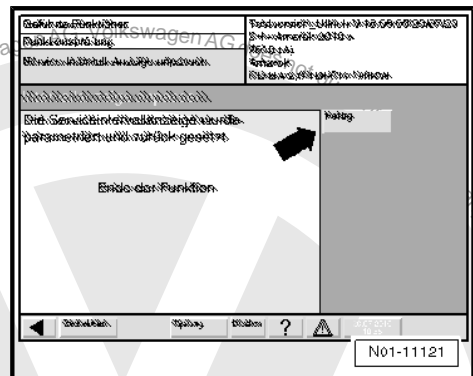



- The service selection window is activated again by pressing the -No- button -arrow-.

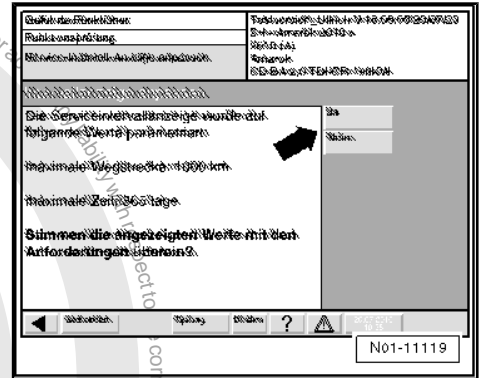

- Confirm end of „Adapt interval“ routine with „Done“ button -arrow-.
- Exit „Guided functions“.
- Switch off ignition.
- Remove vehicle diagnosis, testing and information system - VAS 5051B- or vehicle diagnosis and service information system -VAS 5052 A- from vehicle.

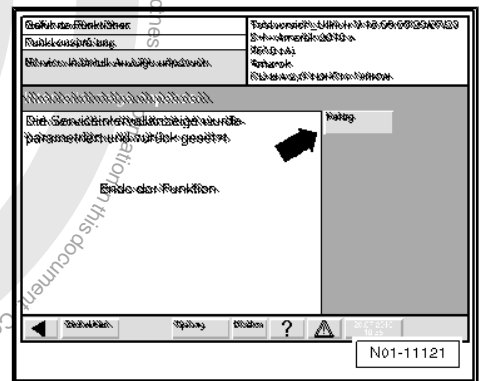

4.50 Service interval: Adjusting (Argentina and Brazil)

Code control unit in dash panel insert -J285- in dash panel insert -K- to 5,000 km, 7,500 km or 10,000 km.

Caution

◆ *Diesel engines: In some regions/countries, an elevated sulphur content may be evident in the diesel fuel. This leads to increased wear of the cylinders and impairs piston cleanliness considerably. Short service intervals therefore apply in this instance => [page 9](#).*

Special tools and workshop equipment required

- ◆ Vehicle diagnostic, testing and information system -VAS 5051B- or subsequent units

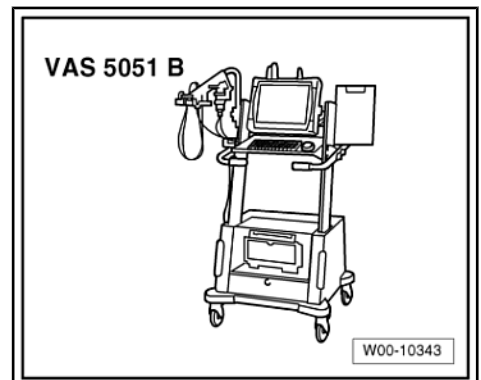

- ◆ Diagnosis cable 5m -VAS 5051B/1-

Or

- ◆ Diagnosis cable -VAS 5051/5A-



Or

- ◆ Vehicle diagnostic and service information system -VAS 5052 A-
- ◆ Diagnosis cable, 2 m -VAS 5052/3 A-

Or

- ◆ Diagnosis cable, 5 m -VAS 5052/3 A-1-
- ◆ Battery charger -VAS 5903-

Or

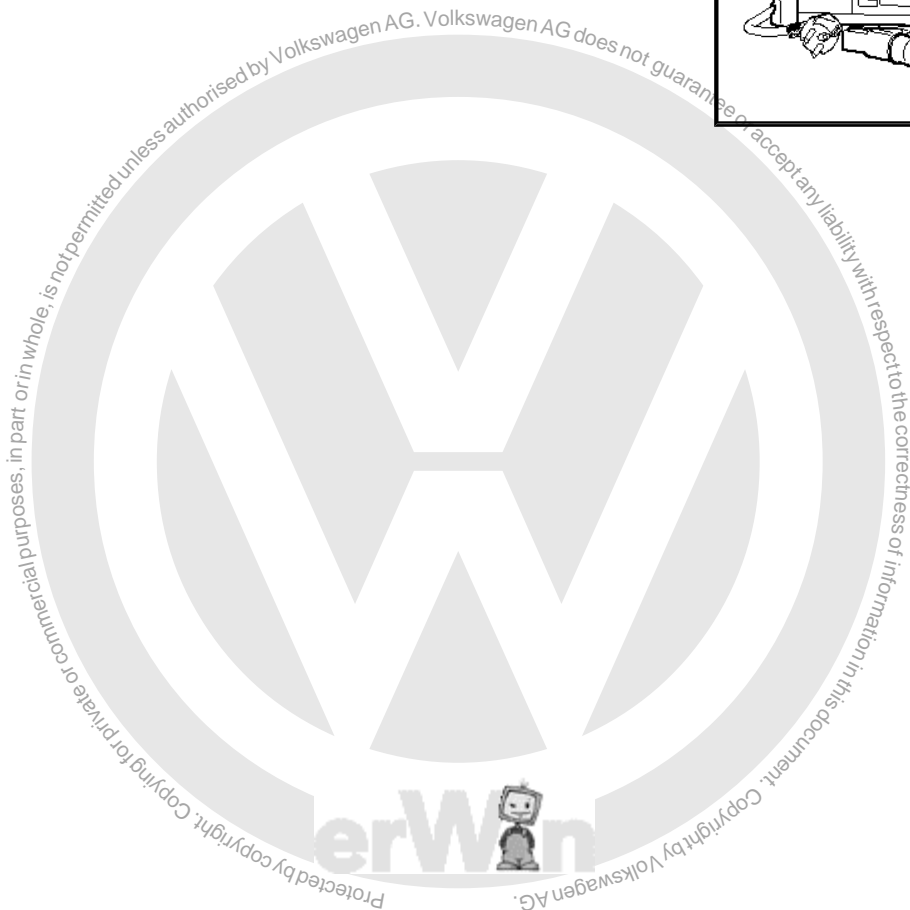
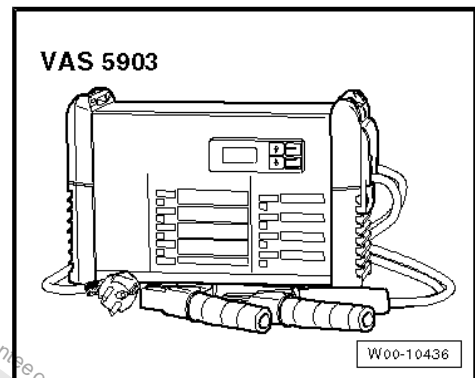
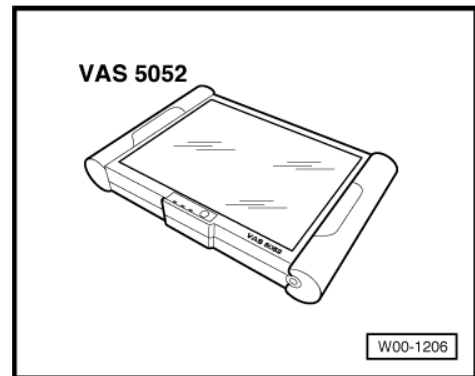



◆ Battery charger, 60A -VAS 5904-

Perform the following jobs:

- Connect vehicle diagnostic, testing and information system - VAS 5051B- or vehicle diagnostic and service information system -VAS 5052 A- => [page 71](#) .



Note

Observe current operating instructions for vehicle diagnostic, testing and information system -VAS 5051B- or vehicle diagnostic and service information system -VAS 5052 A-, which are shown on display after selecting the functions Administration and Operating manual.

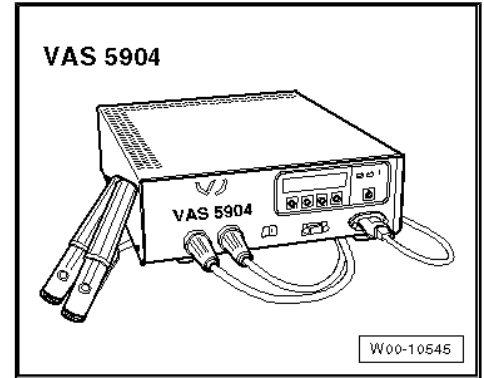

- Switch on ignition.
- Touch the Guided functions field on the screen.
- Then perform vehicle identification on vehicle diagnostic, testing and information system -VAS 5051B- or vehicle diagnostic and service information system -VAS 5052 A- .

- Select one after another:

- ◆ Brand
- ◆ Type
- ◆ Model year
- ◆ Version
- ◆ Engine code

- Confirm vehicle identification.
- If the vehicle identification has been performed correctly, confirm with button.

- Select one after another:

- Select „17 - Dash panel insert“ -arrow-

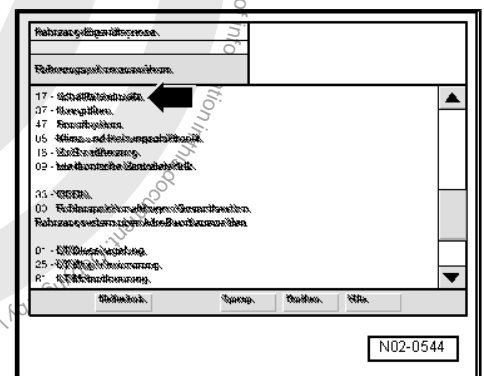



- Select „17 - Adapt service interval“ -arrow-



Note

- ◆ With this function, the service interval display is adapted for vehicles without LongLife service (production control number „QG0/G1“.
- ◆ If this function is performed on vehicles with LongLife service, the extended service interval (ESI) is deactivated.

- Press button -arrow-.

- If necessary, connect battery charger -VAS 5903- or battery charger, 60A -VAS 5904- .

- Press „Done“ button -arrow-.

- Select service with „1 - Delivery inspection“ ⇒ [page 124](#) -arrow- or „2 - Other service work“ ⇒ [page 125](#) button.

„1“ Delivery inspection

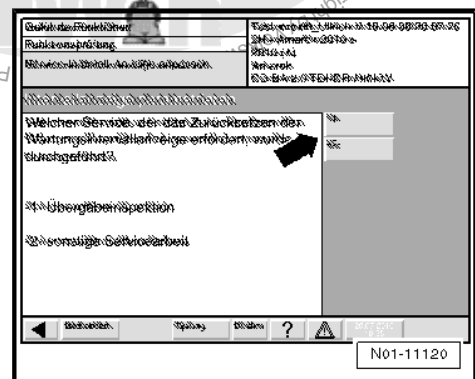
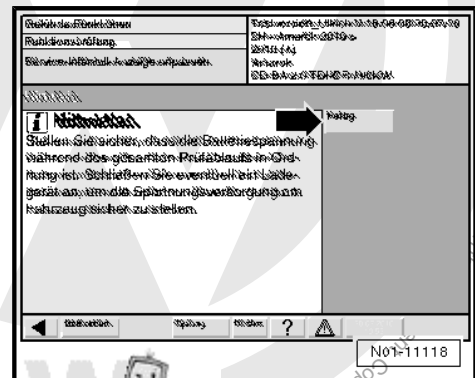
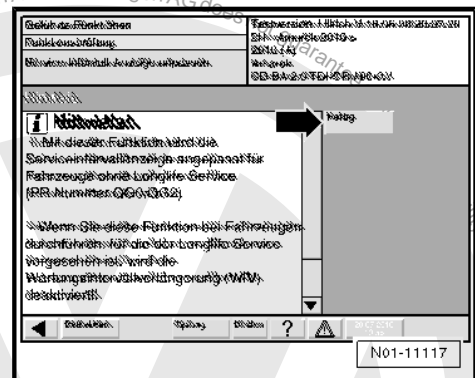
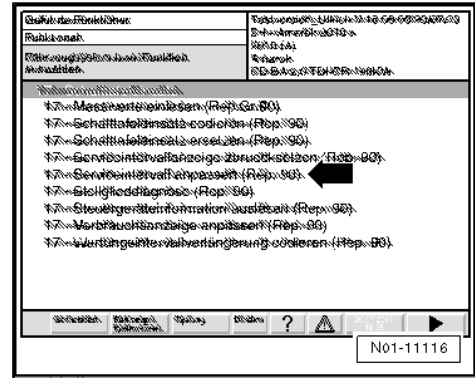

Protected by copyright. Copying for private/commercial purposes, in part or in whole, is not permitted unless authorised by Volkswagen AG, Volkswagen AG, Volkswagen AG. With respect to the correctness of information.



- Confirm vehicle market query with „Yes“ or „No“ -arrow-.



Note

Keep confirming the vehicle market query with „Yes“ or „No“ until the desired country appears on the display.

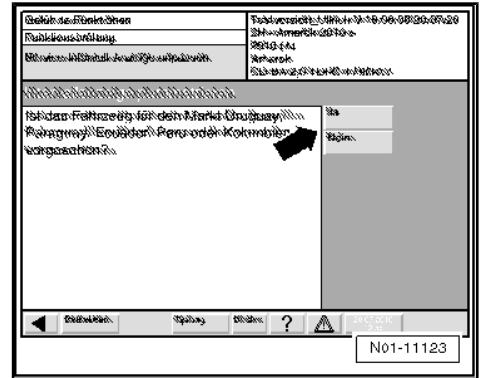

- Confirm end of „Adapt interval“ routine with „Done“ button -arrow-.
- Exit „Guided functions“.
- Switch off ignition.
- Remove vehicle diagnosis, testing and information system -VAS 5051B- or vehicle diagnosis and service information system -VAS 5052 A- from vehicle.

„2“ Other service work

- Select „km“ in next window with -1 to 4- button.
- The chosen setting is adopted by pressing the -Yes- button -arrow-.
- The service selection window is activated again by pressing the -No- button -arrow-.

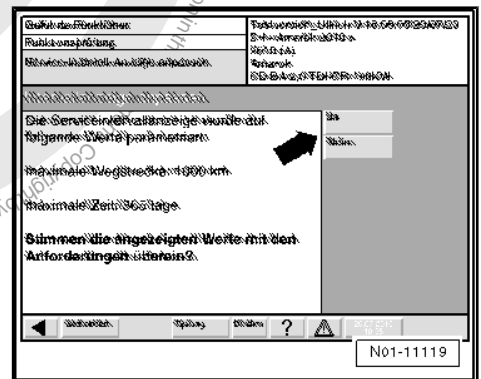
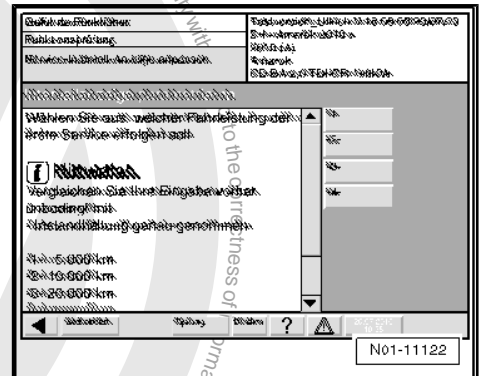
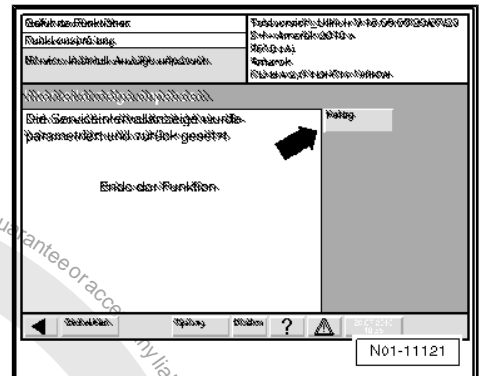



Perform the following jobs:

- Unscrew sealing cover -arrow- with built-in dipstick from tank.
Wipe off dipstick using a clean cloth.
- Screw sealing cover on until finger tight and then unscrew again. Following this, fluid level can be checked.

The oil level must be in area of „cool“ marking.

Tolerance: 2 mm above or below marking.



Note

- ◆ *If the fluid level is above the area specified, the excessive fluid must be extracted.*
- ◆ *If fluid level is below specified area, hydraulic system must be checked for leaks (repair measure).*
- ◆ *If the hydraulic system is not leaking, replenish required quantity of hydraulic oil -G 002 000- .*

Screw sealing cover onto tank until finger tight.

4.52.2 Fluid at operating temperature (from approx. 50 °C)

Test prerequisites

- Engine switched off
- Front wheels in straight-ahead position

Perform the following jobs:

- Unscrew sealing cover -arrow- with built-in dipstick from tank.
- Wipe off dipstick using a clean cloth.
- Screw sealing cover on until finger tight and then unscrew again, after which fluid level can be checked.

The oil level must be between the „cool“ and the „hot“ marking.



Note

- ◆ *If the fluid level is above the area specified, the excessive fluid must be extracted.*
- ◆ *If fluid level is below specified area, hydraulic system must be checked for leaks (repair measure).*
- ◆ *If the hydraulic system is not leaking, replenish required quantity of hydraulic oil -G 002 000- .*

- Screw sealing cover onto tank until finger tight.

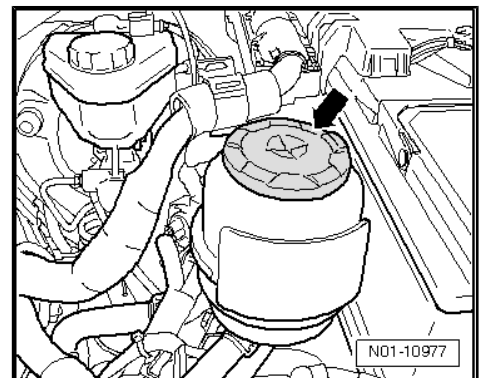
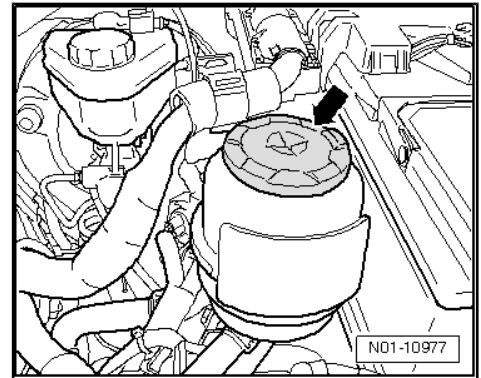



4.53 Doors: Grease door arrester

Perform the following jobs:

- Lubricate door arrester at positions marked -arrows-.
- Use lubricating paste -G 000 150- or lock cylinder lubricating spray -G 052 778 A2- .

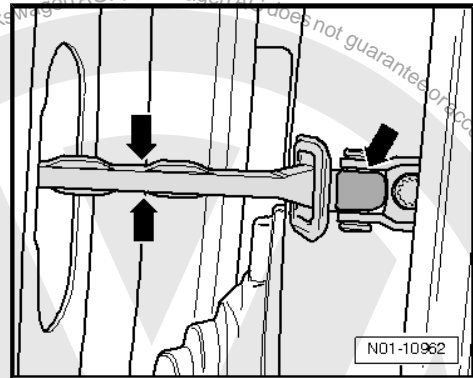

4.54 Paint: Perform visual check for damage and corrosion, interior and exterior when doors and bonnet/rear lid/flaps are open

Perform the following jobs:

- Visual check on paint for damage and corrosion, interior and exterior when bonnet/rear lid/doors and flaps are open.
- After the visual check, tick the corresponding field in the service record.

If damage is determined during visual check, make entries in the service schedule:

- Put a cross in „Repair recommendation“ on „Service record“ page in service schedule.
- Additionally describe exactly what part of vehicle is affected or damaged etc. in field „Notes“ below „Workshop comments“ in the service schedule.



Note

- ◆ Inform the customer when faults are found during visual check and repair measures are necessary.
- ◆ Faults found must always be rectified (repair measure). Therefore, further damage and corrosion and rusting through can be avoided.

4.55 Protective foil: Remove (if fitted)



Note

The foil must „NOT“ be removed from the rear bumper on Amarok models in „Russia“ with chrome bumpers.

Reason:

In Russia, the roads are gritted with calcium chloride in winter. This aggressive substance could corrode the chrome coating.



4.56 Underbody protection: Perform visual check for damage

During visual check, also check floor pan, wheel housings and sills.



Note

Faults found must always be rectified (repair measure). This inhibits corrosion and rusting through.

4.57 Clock: Set to correct time

Vehicles without digital tachograph

- Setting buttons -A and B- are located in dash panel insert -K- .



Note

Clock -B- can only be set when the time is displayed in the dash panel insert -K- and is not overlaid with another display.

Perform the following jobs:

- Switch on ignition.
- To access hour display -B- in dash panel insert -K- , press button -A-.
- Briefly pressing **0.0 / SET** -A- changes time by one hour for every press.
- Pressing **0.0 / SET** -A- for longer changes hour value quickly.

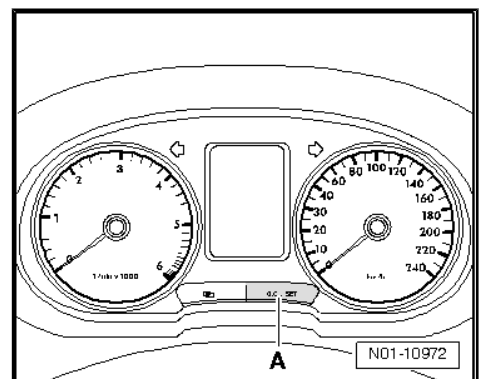
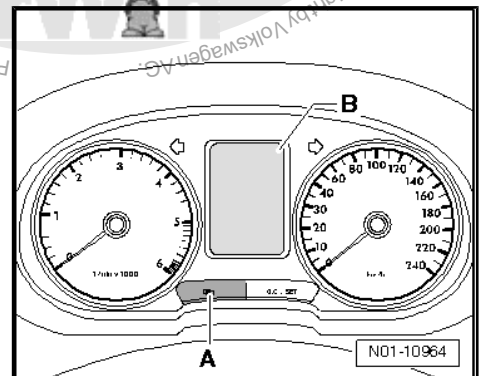
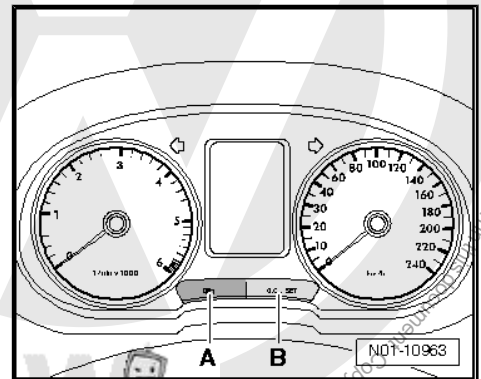



- Press button -A- again to mark the minute display.
- Briefly pressing **0.0 / SET** -A- changes time by one minute for every press.

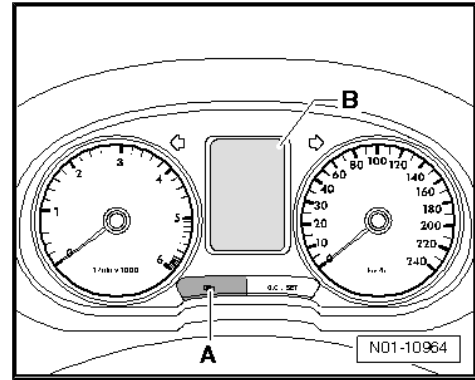

- Pressing **0.0 / SET** -A- for longer changes minute value quickly.

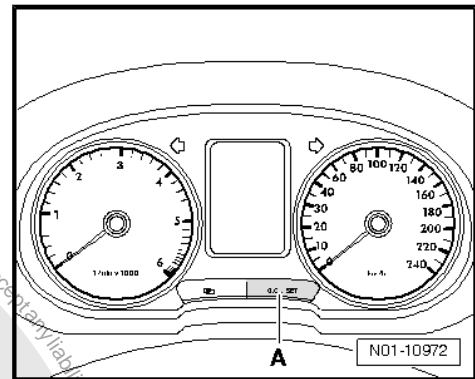

- Pressing -A- button again finishes time setting.

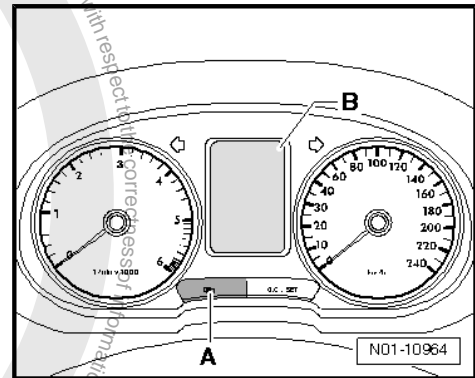

4.58 Camshaft drive toothed belt and toothed belt tensioning roller: Renew

- The procedure is described in workshop manual ⇒ Rep. gr. 15 .

4.59 Camshaft drive toothed belt: Check condition

Applicable to

- ◆ Diesel engines in „dusty“ regions
- ◆ Diesel engines

Perform the following jobs:

- Remove toothed belt guard ⇒ Rep. gr. 15 .



- Check toothed belt condition, looking for:
 - ◆ -A- Cracks, cross-sectional breaks, cracks (coating)
 - ◆ -B- Side contact
 - ◆ -C- Fraying of cord strands
 - ◆ -D- Cracks (in teeth base)
 - ◆ Layer separation (toothed belt body, draw strands)
 - ◆ Surface cracks (synthetic coating)
 - ◆ Traces of oil and grease

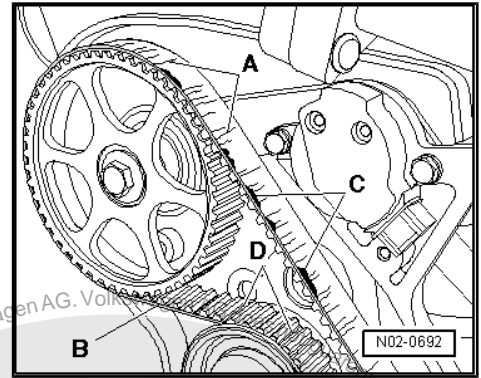

i Note

If faults are found always renew toothed belt. This will avoid possible breakdowns or operating problems. The replacement of a toothed belt is a repair measure.

4.60 Coolant pump toothed belt sprocket and toothed belt: Renew

- The procedure is described in workshop manual ⇒ Rep. gr. 19.

4.61 Spark plugs: Renew

i Note

Observe disposal regulations!

Special tools and workshop equipment required

- ◆ Torque wrench -V.A.G 1331/-
- ◆ Spark plug socket and extension -VAS 3122B-

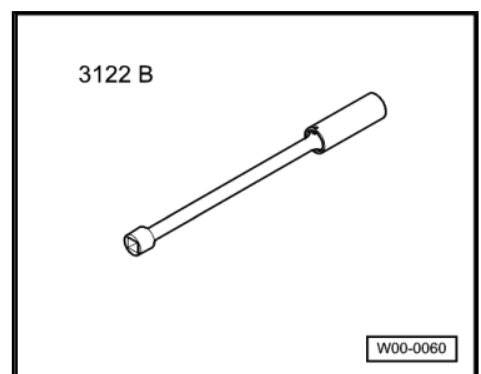
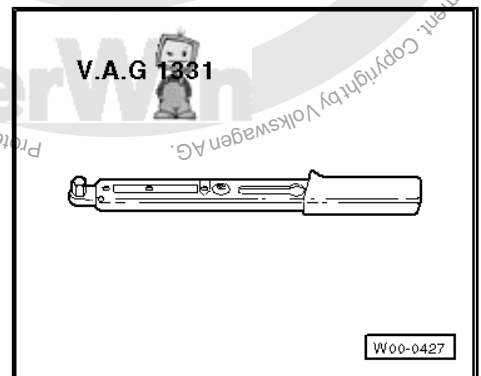



◆ Puller -T40039-

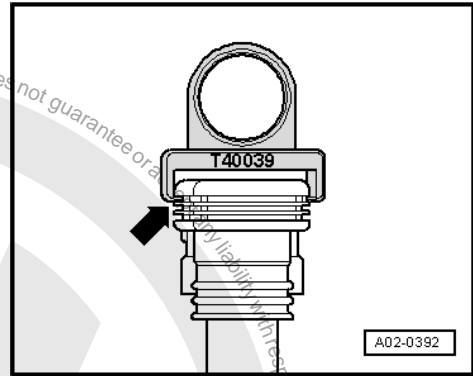

Removing

Perform the following jobs:

- Pull out all ignition coils with final output stage from cylinder head approx. 30 mm using puller -T40039- .

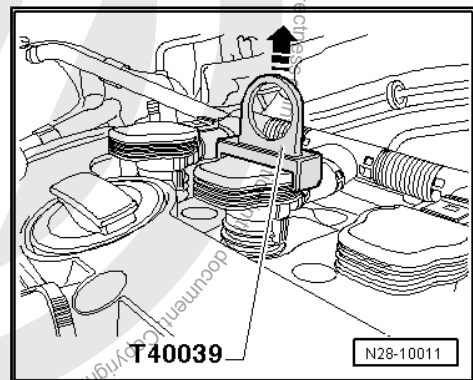

- Release connector -arrows- and simultaneously pull all connectors off ignition coils with final output stage.
- Remove ignition coil with output stage.
- Unscrew spark plugs using spark plug socket and extension -VAS 3122B- .

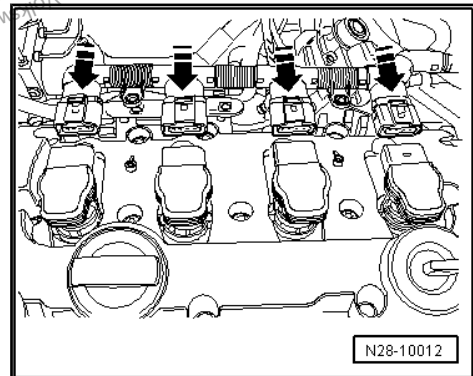

Installing

Perform the following jobs:

- Install new spark plugs using spark plug socket and extension -VAS 3122B- .

Specified torques: 30 Nm

- Insert all ignition coils with output stages loosely into spark plug shaft.
- Align ignition coil with final output stage to connector -arrows- and fit simultaneously.

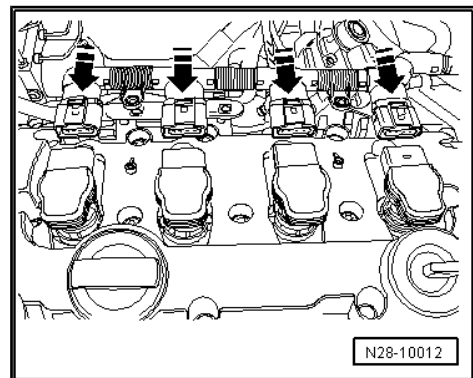

i Note

Do not strike with a hammer or other types of tools.

- Evenly push ignition coils with final output stages onto spark plugs by hand.



4.62 Removing and installing skid plate

Torque wrench -V.A.G 1331- (6-50 Nm)



Note

Get a second mechanic to help you to remove and install skid plate.

Perform the following jobs:

- Unscrew bolts -2-, -3- and -4- one after another.
- Remove skid plate -1- in -direction of arrow-.



Note

The assembly steps are basically a reverse of the dismantling procedure.

- Tighten bolts.
- Specified torques: 20 Nm

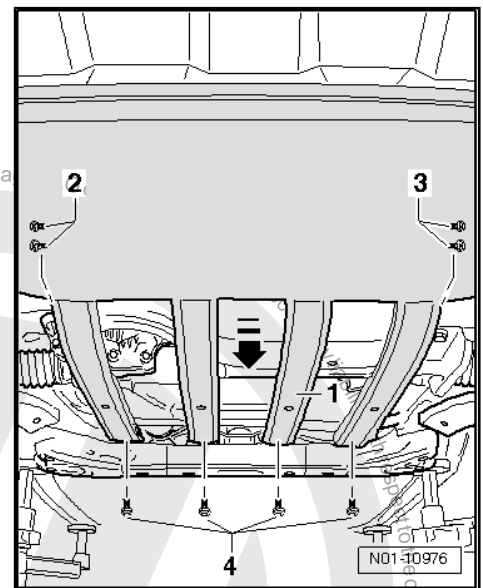
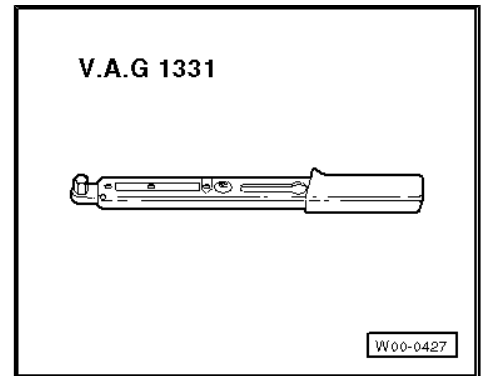

4.63 Steering: Check bellows for leaks and damage

Perform the following jobs:

- Check bellows of steering -arrow- for leaks and damage on respective side.

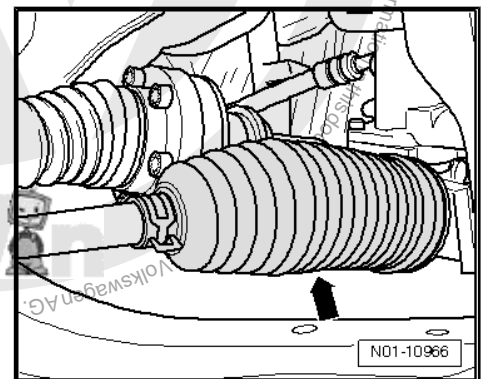



5 Exhaust emissions test



Note

The following exhaust emissions test description is applicable only in countries where no specific exhaust emission regulations have to be adhered to.

Exhaust emissions test intervals in Germany:

Vehicles with regulated catalytic converter or vehicles with diesel engine:

- ◆ 3 years after initial registration and then every 2 years.
- ◆ Vehicles for commercial passenger transport, e.g. taxis: every 12 months

General for exhaust emissions test ⇒ [page 134](#)

Exhaust emissions test for petrol engines with engine code CFPA ⇒ [page 135](#)

Exhaust emissions test for diesel engines with engine codes CDBA, CDCA ⇒ [page 142](#)

Exhaust emissions test with OBD ⇒ [page 144](#)

5.1 General information for exhaust emissions test

5.1.1 Exhaust emissions test intervals

Vehicles with petrol and diesel engine and OBD:



Note

- ◆ *Observe country-specific legal regulations.*
- ◆ *Exhaust emissions test badges are omitted as of 1 January 2010; only the main inspection badges are then available.*
- ◆ *Existing exhaust emissions test badges will be removed from the vehicle by the test centres at the next main inspection or so-called "repair badges" will be affixed over them.*
- ◆ *If the OBD test is carried out, the inspector must issue an exhaust emissions test record according to Annex VIII No. 3.1.1.1 German vehicle licensing regulations.*
- ◆ *No obligation of storage and submission exists for the exhaust emissions test records if the exhaust emissions test record has been transferred to the main inspection test report by the officially recognised expert.*



5.2 Exhaust emissions test for petrol engines with engine code CFPA

Note

- ◆ *The following description refers to vehicles fitted with „On-board diagnosis“ (OBD) and regulated catalytic converter.*
- ◆ *The OBD monitors all components and part systems influencing the exhaust emissions quality.*

Special tools and workshop equipment required

- ◆ Emissions testing station -VAS 6300-

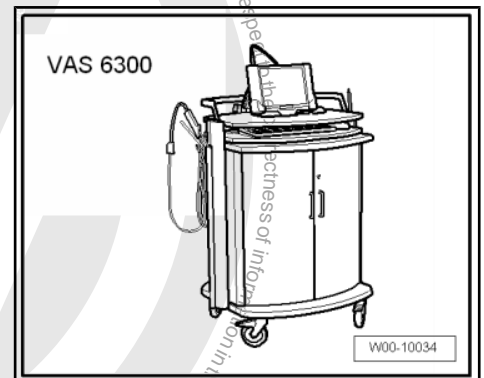

- ◆ OBD adapter cable -VAS 5052/16-
- ◆ Data sheets for exhaust emissions test

Note

- ◆ *It is only possible to carry out an exhaust emissions test when all units of the emissions testing station -VAS 6300- are connected properly and combined with each other according to the => operating instructions .*
- ◆ *All work to be performed is displayed by the emissions testing station -VAS 6300- .*

Test prerequisites

- All test conditions and data required for exhaust emissions test
=> Data sheets for exhaust emissions test for respective engine
- For bar code reading the EET data sheet must be printed out.
- Manual gearbox: Gear lever in neutral
- Handbrake pulled on
- Perform exhaust emission test according to instructions on display.



Initial screen

- Select **Exhaust emissions test** -arrow- button.

An overview is displayed to select the respective EET type.

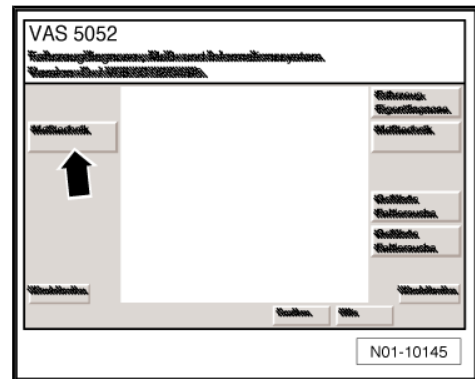

- Select **EET petrol** -arrow-.

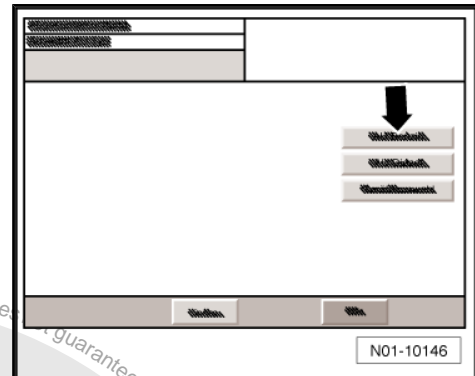

The display for warm-up phase appears.

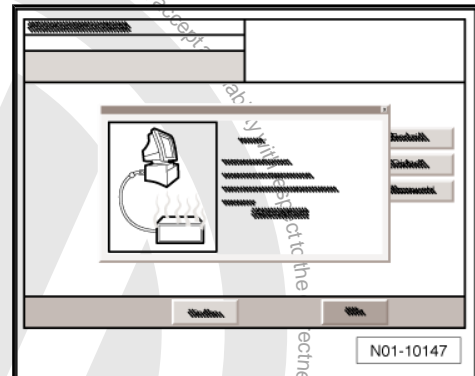

- Continue exhaust emission test according to instructions on display.
- If the EET specification selection is displayed, select respective „EET specification selection“ -arrow-.
- ◆ „Standard values“ when an EET is performed for the first time,
- ◆ Select „Last vehicle“ when an EET is to be carried out again.
- Select **Continue** on display, see -item 1-.

The vehicle data input menu is displayed.

Perform the following jobs:

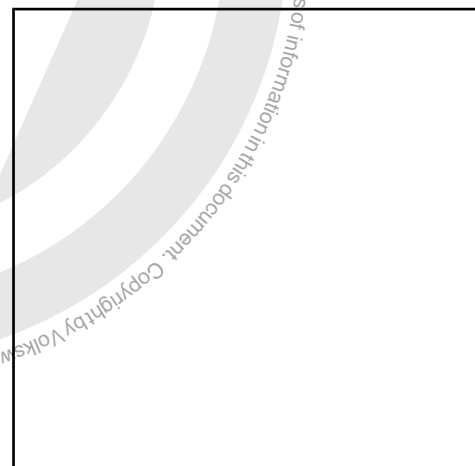



Vehicle data input

- ◆ Vehicle manufacturer -A-
- ◆ Key number -B-
- ◆ Vehicle type -C-
- ◆ Key number -D- (the first 3 digits)
- ◆ For vehicle identification number (chassis number) -E-

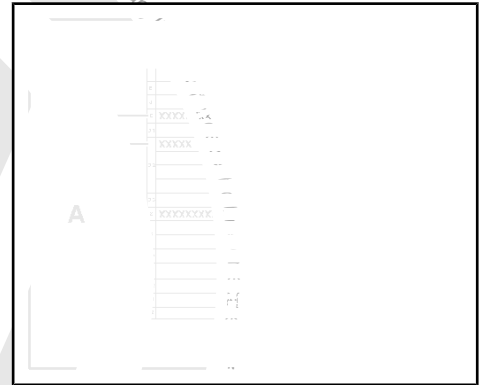

– Enter items 1...7- of vehicle data from vehicle registration certificate.

- ◆ -1- Vehicle manufacturer: „e.g. VOLKSWAGEN - VW“
- ◆ -2- Vehicle type: „e.g. 2H“
- ◆ -3- Key number to 2 (old) or 2.1 (new): „e.g. 0603“
- ◆ -4- Key number to 3 (old) or 2.2 (new): „e.g. 358“
- ◆ -5- Engine code „e.g. CFPA“
- ◆ -6- Registration number: „e.g. WOB-HH 1234“
- ◆ -7- Vehicle identification number: „e.g. WV1ZZZ2HZYW123456“
- ◆ -8- Odometer reading: „e.g. 32000“

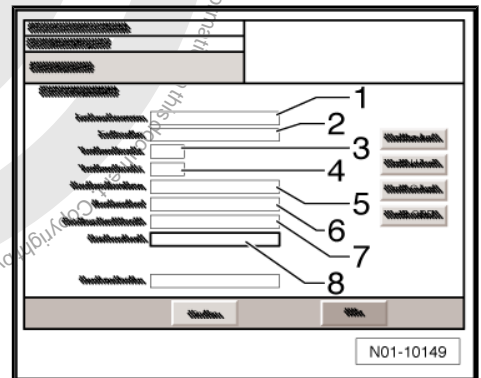

Note

- ◆ Further functions can be called up using GoTo button.
- ◆ The test can be interrupted using GoTo button.

– Select with OBD -arrow-.

Specified data input for EET



Note

- ◆ If specifications are not available as bar code, they are to be entered manually.
- ◆ All test conditions and data required for exhaust emissions test
⇒ Data sheets for exhaust emissions test for respective engine

Manual specified data input for EET:

- Perform manual data input according to instructions on display.

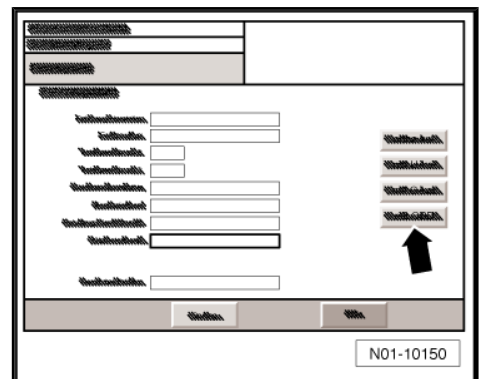



– Enter displayed values on EET data sheet under „Test values for exhaust emissions test“ on display in following sequence:

- 1 - Test speed (idling speed)
 - 2 - Warm-up phase for catalytic converter
 - 3 - Engine temperature
 - 4 - Increased idling speed
 - 5 - CO content at increased idling speed
 - 6 - Lambda at increased idling speed
 - 7 - Idling speed
 - 8 - Select regulating probe type, either „step-type probe“, or „broad-band probe“ -item 1-
 - 9 - Lambda probe value
- When all data have been entered properly, press **Continue** button -arrow-.

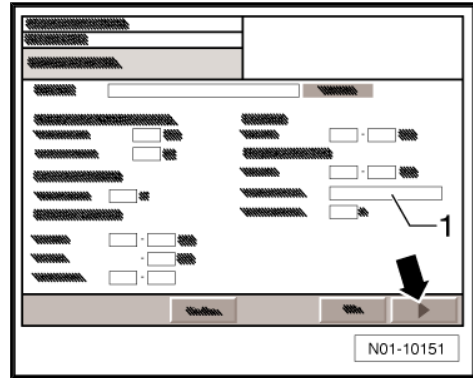

Specified data input for EET as bar code:

- If EET nominal data is present in bar code format then read in bar code of EET data sheet using reader pen.

All data required are shown on display.

- Press **▶** -button- to continue procedure.

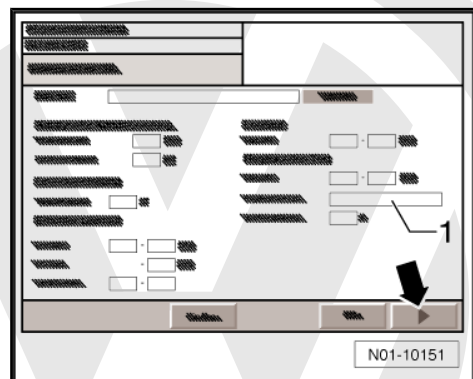

Visual check

- Follow instructions on display.
- Perform visual checks.
- If visual check is OK press **OK** button. Press -arrow-.



Note

When **not OK** button is pressed a check will be carried out.

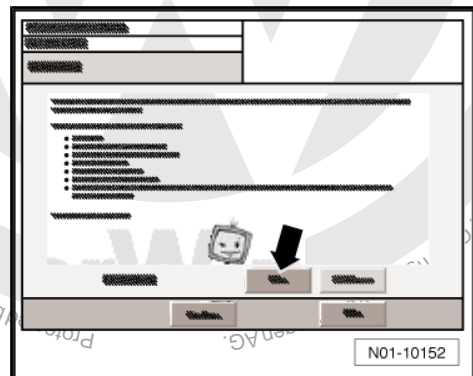

The visual check is displayed with the request to connect the diagnosis connector -arrow A- and to check the MI lamp -arrow B-.

- Follow instructions on display.
- Switch off ignition.

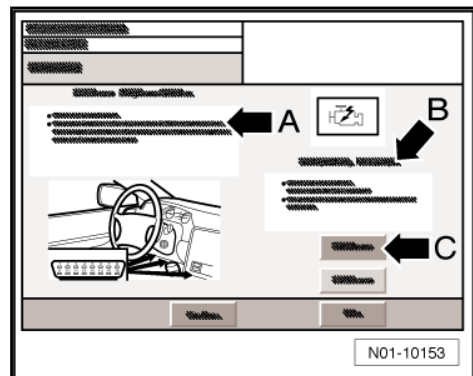



- Connect diagnosis line connector to EOBD connection.
- Switch on ignition.
- Perform visual check of „MI lamp“.
- If lamp lights up, press **Lamp On** button -arrow C-.

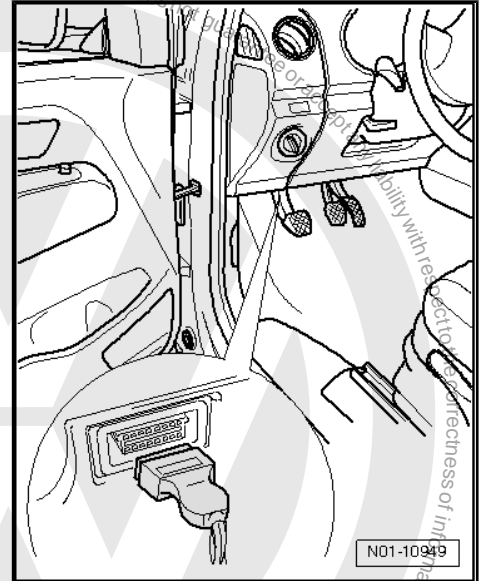

- Follow instructions on display, see -arrow C- and -arrow A-.
- ◆ Start engine.
- ◆ Perform visual check of MI lamp.
- Insert emission probe in exhaust tail pipe.



Note

The exhaust emissions test is only continued when the test probe is in the exhaust tail pipe.



It is automatically switched to test for readiness of operation.

It is checked here if all tests for readiness of operation supported by the control unit have been performed.



Note

- ◆ *If all display values have been set to „0“, a regulating probe test is not performed.*
- ◆ *If not all display values have been set to „0“, a regulating probe test will be performed later.*

- Confirm status of „MI lamp“ -arrow B-.

Catalytic converter conditioning

It is automatically switched to warm-up phase of catalytic converter.

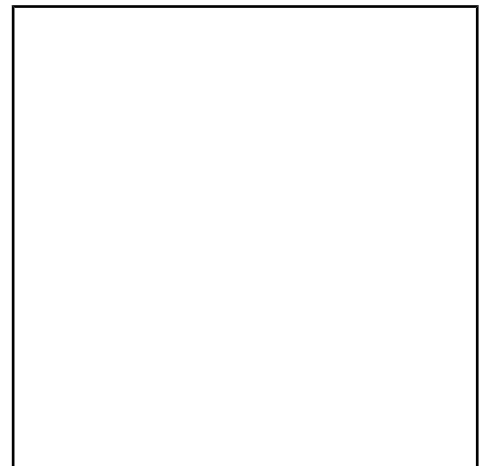



- Follow instructions on display.

Measurement starts when the engine speed has reached the required level.

- Keep engine speed within required rpm range.

The remaining time to perform the warm-up phase is displayed - arrow A -.

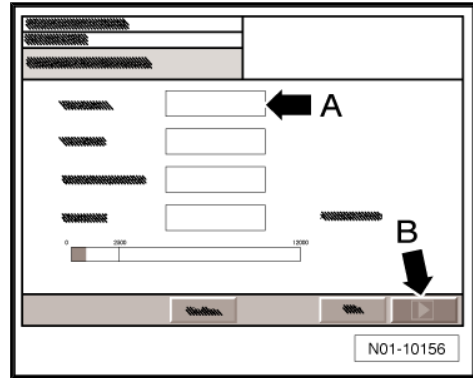

Warm-up phase

It is automatically switched to display for measuring engine temperature.

- Follow instructions on display.



Note

This is only indicated on display if engine temperature has not reached 80 °C.

- Bring engine to required temperature.

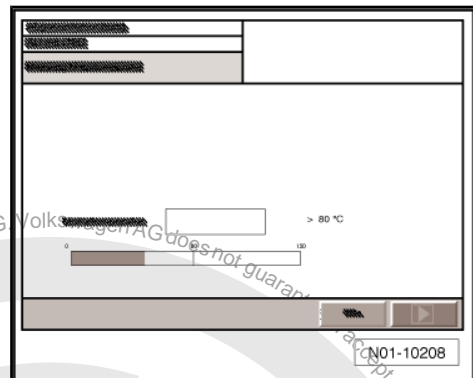

Measurement at increased idling speed:



It is automatically switched to display for measuring increased idling speed.

- Follow instructions on display.

Measurement starts when the engine speed has reached the required level.



Note

- ◆ *Measurement can be skipped using  button, i.e. the exhaust emissions test has failed.*
- ◆ *Measured values are reset using the  button and the test can be repeated.*

- Keep engine speed within required rpm range.

The remaining time to perform measurement is displayed -arrow A-.

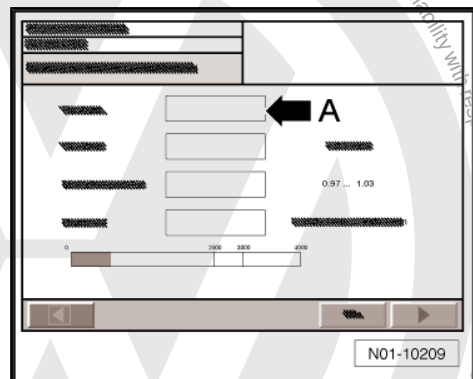



Measuring idling speed and CO content

It is automatically switched to display for measuring the idling speed and CO content.

Measurement starts when the engine speed has reached the required level.

The remaining time to perform measurement is displayed -arrow A-

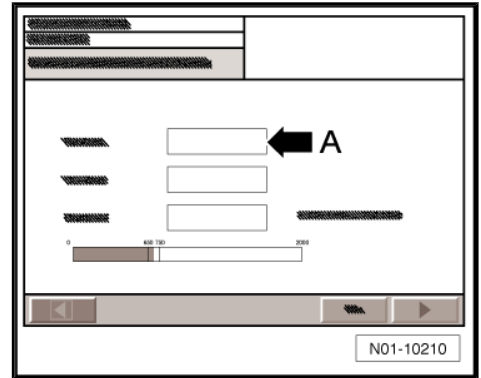

Regulating probe test



Note

The regulating probe test is only performed if „NOT“ all display values have been set to „0“.

It is automatically switched to display for regulating probe test.



Note

The regulating probe test is performed for every lambda probe individually.

Measurement starts when the engine speed has reached the required level.

- Keep engine speed within required rpm range.

The remaining time to perform measurement is displayed -arrow A-

Evaluation

When the exhaust emissions test has been performed, the log is shown on display.

The test result is displayed.

Now remarks concerning the exhaust emissions test can be entered -arrow A-. These will then be included in the test log.

- When the exhaust emissions test is classed as passed, select -arrow B- **EET sticker issued** in drop-down menu and date.
- Then confirm with **Yes**, see -arrow C-

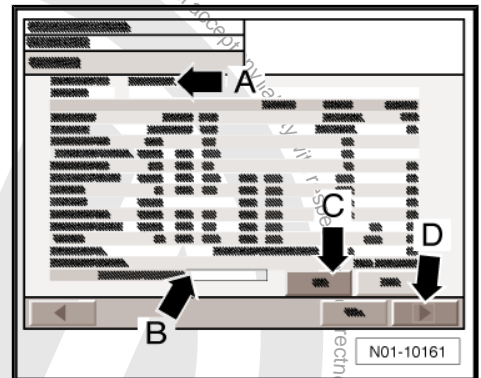

After confirmation, the „2“ „TEST CERTIFICATES“ are printed out automatically.

- If further test certificates are required, press -arrow A- **Print** button.
- Follow instructions on display.
- Remove exhaust probe from exhaust tailpipe.
- Then press **▶** button -arrow B-

The exhaust emissions test is completed, a new exhaust emissions test can be performed.

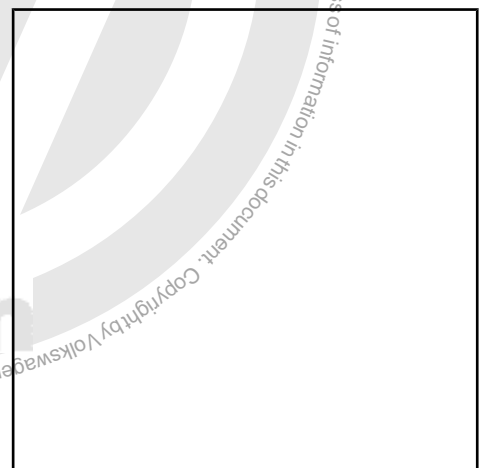



5.3 Exhaust emissions test for diesel engines with engine codes CDBA, CDCA

Special tools and workshop equipment required

- ◆ Diesel tester -V.A.G 1743-

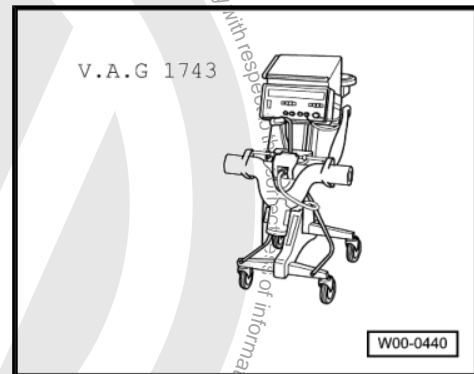

- ◆ Engine speed adapter -VAS 6296-

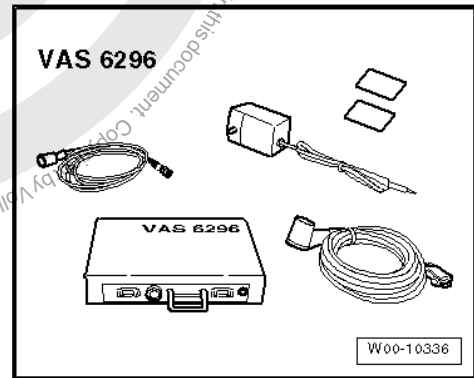

- ◆ Data sheets for exhaust emissions test



Note

- ◆ *All test conditions and data required for exhaust emissions test
⇒ Data sheets for exhaust emissions test for respective engine*
- ◆ *If possible, the test should be completed outdoors following a road test. If this is not possible for various reasons (weather, excessive noise in residential areas), then the test can be carried out in a workshop.*
- ◆ *To reduce noise levels, the bonnet should be closed on first catch during tests.*

Perform the following jobs:

Performing visual check of components that influence pollution.

⇒ Data sheets for exhaust emissions test

– Perform visual check for:

- ◆ Installation
- ◆ Completeness
- ◆ Leakage
- ◆ Damage



Note

Faults found are to be rectified.

With ignition switched off, connect testers as follows:

- Pull on handbrake.
- Manual gearbox: Gear lever in neutral
- Connect diesel tester -V.A.G 1743- according to ⇒ operating instructions with ignition switched off.
- Connect engine speed adapter -VAS 6296- .



Note

- ◆ *Follow ⇒ operating instructions for engine speed adapter -VAS 6296- !*
- ◆ *Strictly follow the safety precautions in the operating instructions!*
- Start engine and run at idling speed.

The engine speed must now be displayed on diesel tester -V.A.G 1743- .

If the engine speed is displayed incorrectly or not at all, use ⇒ operating instructions for VAS 1743 or ⇒ operating instructions for VAS 6296 to rectify the cause.

Perform exhaust emissions test according to instructions on diesel tester -V.A.G 1743- display.

If the following is indicated on display:

n	rpm	mode	k	l/m	T	°C
XXX	XXXX	B	X	XX		XX

Unit ready to carry out measurements.

Check idling speed.

Idling speed not within specified range.



Note

The idling speed and maximum speed can be checked but not adjusted.

- If the values are not within specified range, a repair measure must be made.

Performing acceleration test.

- Press „button for acceleration test“.

First, a fresh air comparison is performed.

If the following is indicated on display:

n	rpm	tB	s	k	l/m	Gas	T	°C	M
XXX	XXXX	-	-	X	XX	0		XX	-

Current values for temperature and speed are displayed.

The arrow pointing upwards indicates that the unit is waiting for the throttle burst.

- Depress accelerator pedal fully and hold for specified time.
- Check maximum engine speed (not adjustable).



WARNING

If the governed speed (maximum speed) is exceeded, lift off accelerator pedal immediately and perform repair measures.

- If the values are not within specified range, a repair measure must be made.

If the unit detects a valid throttle burst (the speed increases continually during measuring period „tx“), the following is indicated on display:

If the following is indicated on display:

n rpm	tB s	k l/m	Gas T °C	M
XXX XXXX	-. -	-. -	1 XX	-

The display remains „frozen“ during the evaluation phase (approx. 15 seconds).

After the evaluation phase, the display changes to:

n rpm	tB s	k l/m	Gas T °C	M
XXX XXXX	X.XX	X.XX	1 XX	-

The arrow pointing upwards indicates that the unit is waiting for the next throttle burst.

Repeat test 4 times.

The following is indicated on display after each throttle burst:

n rpm	tB s	k l/m	Gas T °C	M
XXX XXXX	X.XX	X.XX	X XX	-

In this way, the unit measures and registers at least four throttle bursts. After the fourth and for each further throttle burst sequence, an average of the last three measurements is performed.

The following is indicated on display after each throttle burst:

n rpm	tB s	k l/m	Gas T °C	M
XXX XXXX	X.XX	X.XX	X XX	-

After 10 seconds, this display changes to:

Average	tB s	k l/m	band width	M
	X.XX	X.XX	X.XX	-

After 5 seconds, this display changes to:

Average	tB s	k l/m	band width	M
	X.XX	X.XX	XX	-

The display remains until a further throttle burst is performed or another measurement is called up.

If the opacity figures are equal to or less than the prescribed figures, cease measurements.

If the determined opacity figure is above the prescribed figure, locate fault within repair measure framework → Fault finding engine

5.4 Exhaust emissions test with OBD



Note

- ◆ *The following exhaust emission test description is only applicable in countries where specific exhaust emission regulations have to be adhered to.*
- ◆ *In motor vehicles with spark ignition engine or compression ignition engine which were initially registered for use on the road as of 01.01.2008, measurement and processing of the exhaust emissions behaviour are omitted if all readiness codes are set.*
- ◆ *If „NOT“ all readiness codes are set, an exhaust emissions test must be performed ⇒ [page 134](#).*



Special tools and workshop equipment required

- ◆ Vehicle diagnostic, testing and information system -VAS 5051B-

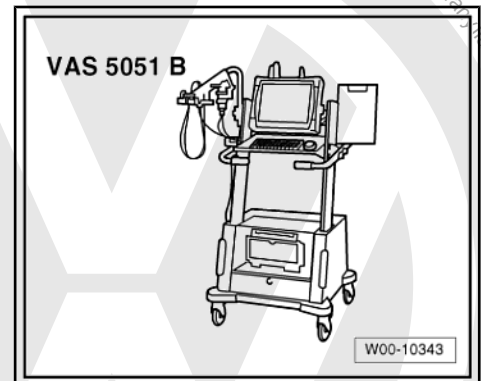

- ◆ Diagnosis cable 5m -VAS 5051B/1-

- ◆ Vehicle diagnostic and service information system -VAS 5052 A-

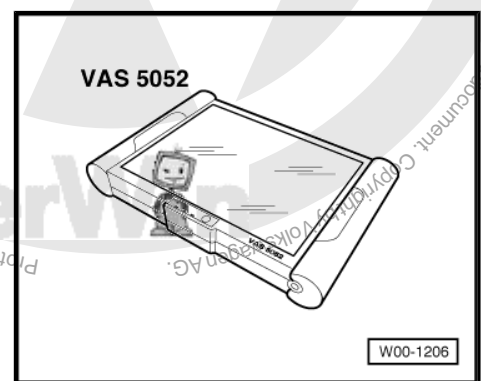

- ◆ Diagnosis cable -VAS 5052/3-

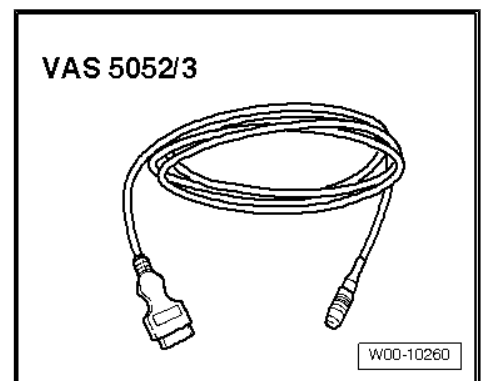

Carry out the following procedure:

- Perform visual check:
 - ◆ Crankcase breather system connected,
 - ◆ Exhaust system must be leaktight,
 - ◆ Catalytic converter and particulate filter present and undamaged.

Checking and adjusting prerequisites:

- ◆ Electrical consumers switched off,
- ◆ Air conditioner switched off,
- ◆ As of an engine oil temperature of at least 60°C, warm the engine to at least 80°C by revving freely 10 times up to the rev. limit.



Note

Faults found are to be rectified.

- Pull on handbrake.
- Manual gearbox: Gear lever in neutral.
- Connect diagnosis cable connector to diagnosis connection with ignition switched off.
- Connect vehicle diagnostic, testing and information system - VAS 5051B- or vehicle diagnostic and service information system -VAS 5052- => [page 71](#) .
- Switch on ignition.

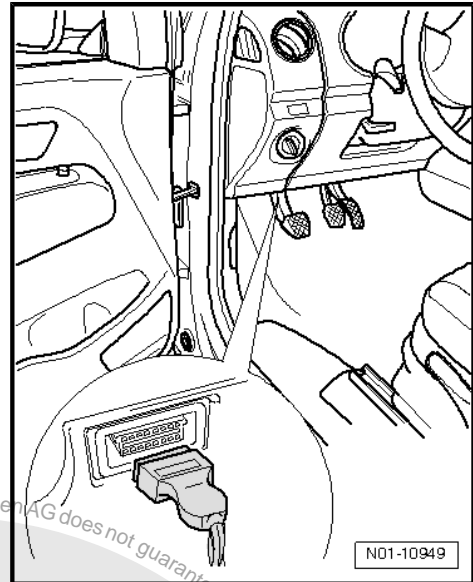

- Press **Guided functions** button -arrow- on display.

Vehicle identification begins.

- Select brand, vehicle model, model year, etc.
- Confirm vehicle identification.

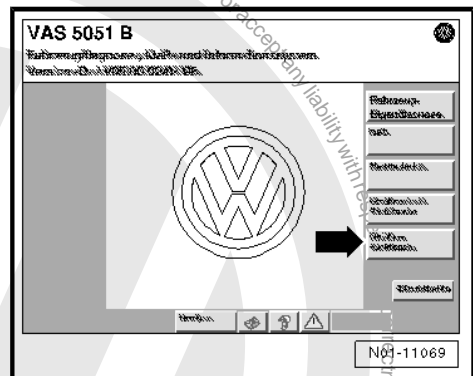

- Select „Engine“ -arrow- in vehicle diagnostic system guided menu.

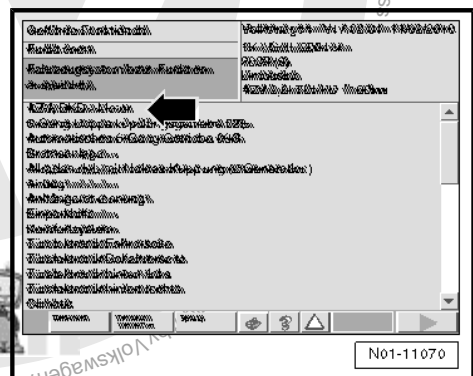



- Select „Generate readiness code“ -arrow-.
- Follow instructions of vehicle diagnostic, testing and information system -VAS 5051B- or vehicle diagnostic and service information system -VAS 5052- .

Evaluation:

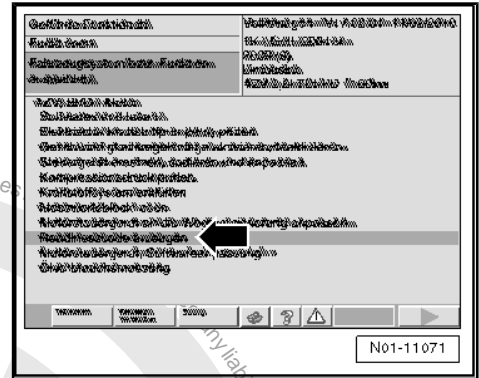

After running through readiness code, result appears on screen.



Note

- ◆ Exhaust emissions test is PASSED when all „ACTUAL values“ correspond to „SPECIFICATIONS“.
- ◆ If not all readiness codes are set, an exhaust emissions test must be carried out => [page 134](#) .
- Print out the evaluation with **Print**.
- End programme.
- Remove vehicle diagnostic, testing and information system - VAS 5051B- or vehicle diagnostic and service information system -VAS 5052- .
- Complete exhaust emissions test record according to Annex VIII No. 3.1.1.1 German vehicle licensing regulations.
- Close fuse box cover on left under dash panel.

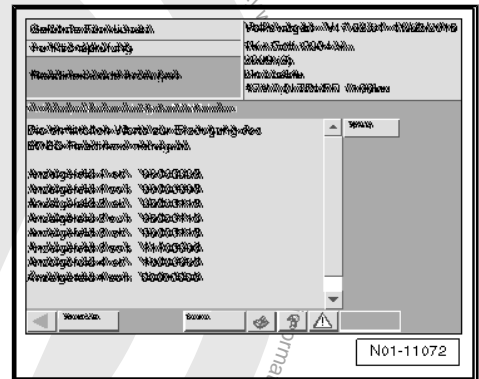

Note

- ◆ Exhaust emissions test badges are omitted as of 1 January 2010; only the main inspection badges are then available.
- ◆ Existing exhaust emissions test badges will be removed from the vehicle by the test centres at the next main inspection or so-called "repair badges" will be affixed over them.
- ◆ No obligation of storage and submission exists for the exhaust emissions test records if the exhaust emissions test record has been transferred to the main inspection test report by the officially recognised expert.



6 Glossary

These explanations only apply to „Maintenance Manual“. They are not necessarily generally valid!

Letter „A“ ⇒ [page 148](#)

Letter „B“ ⇒ [page 148](#)

Letter „C“ ⇒ [page 148](#)

Letter „D“ ⇒ [page 149](#)

Letter „E“ ⇒ [page 149](#)

Letter „F“ ⇒ [page 149](#)

Letter „L“ ⇒ [page 149](#)

Letter „M“ ⇒ [page 149](#)

Letter „O“ ⇒ [page 149](#)

Letter „P“ ⇒ [page 150](#)

Letter „Q“ ⇒ [page 150](#)

Letter „R“ ⇒ [page 150](#)

Letter „S“ ⇒ [page 150](#)

Letter „T“ ⇒ [page 150](#)

Letter „W“ ⇒ [page 150](#)

Letter „X“ ⇒ [page 151](#)

Letter „A“

Term	Explanation
All Season	All-season tyres / all weather tyres An All Season Tyre is a tyre for all seasons.
ABS (anti-lock brake system)	The ABS is a regulating system in the brake system, that prevents locking when braking. This helps to maintain directional stability and steerability.
ATF (Automatic transmission fluid)	Gear oil for automatic gearbox
ATF level	Filling level of ATF in gearbox

Letter „B“

Term	Explanation
Broad-band probe	The broad-band probe is also called universal lambda probe (ULP probe). The voltage of the lambda probe output nearly increases linear. The lambda probe value is determined by a change in voltage. This enables to measure the lambda probe value via a larger measuring range (broad band). The probe is used as before catalytic converter probe.

Letter „C“

Term	Explanation
C - tyres	C-mark is found on light truck tyres. Use correct inflation pressure when changing from „Reinforced tyres“ to „C-mark tyres“.
CO (Carbon monoxide)	Carbon monoxide is produced when fuels containing carbon are not combusted completely.



Term	Explanation
CN (Cetane number)	Measurement unit for ignition quality of diesel fuel

Letter „D“

Term	Explanation
DPF (Diesel particulate filter)	The diesel particulate filter is installed behind the catalytic converter and filters soot particles from emissions.
DIN	Deutsches Institut für Normung e.V. (German Standards Authority)

Letter „E“

Term	Explanation
Part No.	Abbreviation for part number
EN	European standard
EOBD	European onboard diagnosis
ESP	Electronic stabilisation programme (prevents potential vehicle skidding by targeted intervention in the brake and engine management systems)

Letter „F“

Term	Explanation
FAME	Fatty acid methyl ester

Letter „L“

Term	Explanation
LongLife service	The LongLife service enables extremely long inspection or oil change intervals, depending on individual driving style and the conditions under which the vehicle is used. For the LongLife service a special engine oil is required.
LEV	Low Emission Vehicle

Letter „M“

Term	Explanation
M&S	§ 36 of the StVZO (Germany) defines the identification of a winter tyre as „M&S“.
MIL (Malfunction Indicator Light)	American designation for MI lamp -K83-

Letter „O“

Term	Explanation
OBD (Onboard diagnosis)	The OBD monitors all components influencing the exhaust emissions quality.



Letter „P“

Term	Explanation
PR number	Abbreviation for production control number, it identifies among other things optional equipment, country-specific deviations etc.

Letter „Q“

Term	Explanation
QG0	Vehicles are „not“ fitted at the factory with components for LongLife service. For maintenance, the time or distance dependent intervals (non-flexible intervals) apply.
QG1	Vehicles are fitted at the factory with active LongLife service. This means vehicles have a flexible service interval display and are fitted with the following components: <ul style="list-style-type: none"> ◆ Flexible service interval display in dash panel insert ◆ Engine oil level sensor
QG2	The LongLife service is not active at the factory. This means, vehicles have a non-flexible service interval display (time or distance dependent service intervals) and are fitted with the following components: <ul style="list-style-type: none"> ◆ Non-flexible service interval display in dash panel insert ◆ Engine oil level sensor ◆ Brake pad wear indicator (if fitted)

Letter „R“

Term	Explanation
RON (Research Octane Number)	Measurement unit of the knock resistance of petrol
RF	„REINFORCED“, reinforced tyre, additional designation for tyres with increased load capacity

Letter „S“

Term	Explanation
SAM (South American countries)	South America
Step-type probe	The step-type probe is also called finger probe or planar lambda probe. The voltage of the output signal of the lambda probe jumps rapidly. The lambda probe value is determined by a change in voltage. The probe is used as after catalytic converter probe.

Letter „T“

Term	Explanation
TDI (Turbo Diesel Injection)	Turbo diesel engine with direct injection

Letter „W“

Term	Explanation
ESI	Extended servicing interval



Letter „X“

Term	Explanation
XL	„Extra Load“, reinforced tyre, additional designation for tyres with increased load capacity

