



Workshop Manual

Jetta 2005 ➤

Bora 2006 ➤

Electrical System

Edition 05.2005





List of Workshop Manual Repair Groups

Repair Group

- 27 - Starter, current supply, CC
- 90 - Instruments, GCI
- 92 - Windscreen wash/wipe system
- 94 - Lights, lamps, switches - outside
- 96 - Lights, lamps, switches - inside
- 97 - Wiring



Technical information should always be available to the foremen and mechanics, because their careful and constant adherence to the instructions is essential to ensure vehicle road-worthiness and safety. In addition, the normal basic safety precautions for working on motor vehicles must, as a matter of course, be observed.

All rights reserved.
No reproduction without prior agreement from publisher.



Contents

27 - Starter, current supply, CC	1
1 Battery	1
1.1 Fundamentals for batteries	1
1.2 Types of battery	1
1.3 Warning notices and safety regulations	2
1.4 Battery terminal connection	4
2 Checking battery	5
2.1 Procedure when checking the battery	5
2.2 Visual check	5
2.3 Checking battery with magic eye	6
2.4 Checking low maintenance battery	7
2.5 Check no load voltage of battery	10
2.6 Battery tester with printer VAS 5097 A	11
2.7 Evaluating test result	14
3 Charging battery	15
3.1 Battery charger VAS 5095 A	15
3.2 Battery charger VAS 5900	19
3.3 Totally discharged batteries	27
4 Disconnecting and reconnecting batteries	29
4.1 Disconnecting battery	29
4.2 Connecting battery	29
5 Removing and installing battery	31
5.1 Models with a petrol engine	31
5.2 Models with a diesel engine	32
6 Torque settings: battery	36
7 Starter	37
7.1 Checking starter B	37
7.2 Removing and installing starter, automatic gearbox	38
7.3 Removing and installing starter, automated shift gearboxes	58
7.4 Removing and installing starter, manual gearbox	76
8 Torque settings: starter	97
9 Alternator	98
9.1 Fastening B+ wire to alternator	98
9.2 Checking ribbed belt (poly V-belt)	98
9.3 Check alternator C	99
9.4 Alternator, 1.6 l injection engine	99
9.5 Alternator, 1.6 l FSI engine	104
9.6 Alternator, 2.0 l FSI engine	108
9.7 Alternator, 2.0 l FSI turbo engine	115
9.8 Alternator 2.5 l injection engine	122
9.9 Alternator, 1.9 l TDI engine	126
9.10 Alternator, 2,0 l TDI engine	133
9.11 Removing and installing ribbed belt (poly V-belt) pulley on alternator	137
9.12 Voltage regulator for alternator	142
10 Torque settings: alternator	145
10.1 General torque settings for all vehicles	145
10.2 1.6 l injection engine and 2.0 l FSI engine	145
10.3 2.0 l FSI turbo engine	146
10.4 1.9 l and 2.0 l TDI engine	147
10.5 2.5 l injection engine	148
11 Cruise control system (CCS)	149



11.1	Activating and deactivating cruise control system	149
90	- Instruments, GCI	150
1	Dash panel insert	150
1.1	Renewing dash panel insert	150
1.2	Removing and installing dash panel insert	151
1.3	Description of reverse side of dash panel insert	152
1.4	Warning lamp symbols in dash panel insert	152
2	Service interval display	154
2.1	Resetting service interval display	154
92	- Windscreen wash/wipe system	155
1	Windscreen wiper system	155
1.1	Deactivating APP function of wiper motors	155
1.2	Removing and installing the windscreen wiper system	156
1.3	Removing and installing wiper arms	160
1.4	Adjusting wiper blade park position	161
1.5	Removing and installing aerodynamic wipers	162
1.6	Removing and installing rain and light detector sensor G397	163
2	Windscreen washer system	165
2.1	Assembly overview of windscreen washer system	165
2.2	Removing and installing reservoir for windscreen and headlight washer systems	166
2.3	Removing and installing washer pump V5	168
2.4	Removing and installing windscreen washer spray jets	169
2.5	Adjusting front windscreen washer system spray jets	169
3	Headlight washer system	170
3.1	Assembly overview - headlight washer system	171
3.2	Removing and installing headlight washer system pump V11	171
3.3	Removing and installing pop-up spray jet cylinder	172
3.4	Removing and installing spray jet assembly	173
3.5	Adjusting headlight washer system jets	173
3.6	Bleeding the headlight washer system	173
4	Wash water line hose couplings	174
4.1	Windscreen and rear window washer system	174
4.2	Headlight washer system	175
5	Hose repair	176
5.1	General description	176
5.2	Repairing smooth pipe	176
5.3	Repairing corrugated pipe	176
6	Torque settings: Windscreen wash/wipe system	178
94	- Lights, lamps, switches - outside	179
1	Headlight	179
1.1	Assembly overview, Headlight	179
1.2	Removing and installing headlights	181
1.3	Adjusting headlight installation position	182
1.4	Renewing headlight bulbs	184
1.5	Servicing headlight securing lugs	188
1.6	Adjusting headlights	189
2	Main headlights with gas discharge bulbs	190
2.1	Assembly overview - gas discharge headlights	191
2.2	Removing and installing headlights	192
2.3	Adjusting headlight installation position	192
2.4	Renewing headlight bulbs	192
2.5	Removing and installing headlight range control motor	198



2.6	Removing and installing gas discharge light control unit	198
2.7	Headlight range control unit J431	198
2.8	Vehicle level sender	201
2.9	Servicing headlight securing lugs	204
2.10	Adjusting headlights	204
3	Fog lights	205
3.1	Assembly overview - fog light	205
3.2	Removing and installing fog lights	205
3.3	Removing and installing fog light bulb	206
3.4	Adjusting fog lights	207
4	Removing and installing side marker in front bumper	208
4.1	Removing and installing front side marker	208
5	Mirror turn signal bulb and entry light in exterior mirror	209
5.1	Removing and installing turn signal bulb	209
5.2	Removing and installing entry light in exterior mirror	210
6	Tail lights	212
6.1	Assembly overview - tail light in side panel	212
6.2	Removing and installing tail light in side panel	212
6.3	Removing and installing tail light bulb carrier in side panel	213
6.4	Assembly overview - tail light in tailgate	214
6.5	Removing and installing tail light in tailgate	214
6.6	Removing and installing tail light bulb carrier in tailgate	215
7	Number plate lights	217
7.1	Removing and installing number plate light X	217
8	Additional brake light	218
8.1	Removing and installing high level brake light bulb M25	218
9	Steering column switch	219
9.1	Assembly overview - steering column switch	220
9.2	Removing and installing steering column switch	220
9.3	Steering column electronics control unit J527	227
9.4	Steering angle sender G85	228
10	Ignition switch and lock cylinder	229
10.1	Removing and installing steering lock housing	229
10.2	Removing and installing lock cylinder	229
10.3	Removing and installing ignition switch	231
11	Parking aid	233
11.1	Assembly overview - parking aid	234
11.2	Removing and installing parking aid control unit J446	234
11.3	Removing and installing parking aid sensor	235
11.4	Removing and installing rear parking aid warning buzzer H15	236
11.5	Final control diagnosis	236
12	Torque settings: lights, bulbs, switches - exterior	238
12.1	Torque settings: headlight	238
12.2	Torque settings: fog lights	238
12.3	Torque settings - tail light in side panel	238
12.4	Torque settings - tail light in tailgate	238
12.5	Torque settings: vehicle level sender	238
96	Lights, lamps, switches - inside	239
1	Lights and switches in engine compartment	239
1.1	Removing and installing bonnet contact switch F266	239
2	Lights and switches in dash panel	240
2.1	Removing and installing light switch E1	240
2.2	Removing and installing glove compartment light W6	241



2.3	Removing and installing glove compartment light switch E26	242
2.4	Removing and installing switches and instruments illumination regulator E20	242
2.5	Removing and installing front passenger side airbag deactivated warning lamp K145	243
2.6	Removing and installing hazard warning light switch E3	244
2.7	Removing and installing left footwell light W9 and right footwell light W10	244
2.8	Removing and installing key operated switch to deactivate front passenger side airbag E224	246
3	Lights and switches in front doors	248
3.1	Removing and installing window regulator switch in front passenger door E107	248
3.2	Removing and installing switch module for driver side mirror adjustment	248
3.3	Removing and installing driver side interior locking button for central locking system E308	249
3.4	Components - front door locks	250
3.5	Removing and installing switch module for driver side window lift	250
3.6	Removing and installing remote release button for fuel filler flap and rear lid E463 and key operated switch to block release of rear lid remote E232	252
4	Lights and switches in rear doors	254
4.1	Components - front door locks	254
4.2	Removing and installing rear left window regulator switch, in door E52 and rear right window regulator switch, in door E54	254
5	Lights and switches in luggage compartment	256
5.1	Removing and installing luggage compartment light W3	256
5.2	Removing and installing rear lid lock unit F256	257
6	Lights and switches in roof trim	258
6.1	Removing and installing front interior light and reading light (vehicles with no sliding sunroof)	258
6.2	Removing and installing front interior light and reading light (vehicles with sliding sunroof)	261
6.3	Rear interior and reading light (vehicles without ATAS)	265
6.4	Rear interior and reading light (vehicles with ATAS)	267
6.5	Removing and installing front passenger side illuminated vanity mirror W14 and driver side illuminated vanity mirror W20	269
6.6	Removing and installing garage door operating unit E284	271
7	Lights and switches in centre console	272
7.1	Removing and installing TCS and ESP button E256	272
8	Horn	274
8.1	Removing and installing treble tone horn H2 and bass tone horn H7	274
8.2	Checking treble tone horn H2 and bass tone horn H7	274
9	Immobilizer	275
9.1	Immobilizer control unit J362	275
9.2	Immobilizer reader coil D2	275
9.3	Ignition key	275
10	Anti-theft alarm system (ATAS)	277
10.1	Activating and deactivating anti-theft alarm system	277
10.2	Removing and installing anti-theft alarm ultrasonic sensor G209	278
10.3	Removing and installing vehicle inclination sender G384	278
10.4	Central locking and anti-theft alarm system aerial R47	278
10.5	Alarm horn H12	279
97 - Wiring		281
1	Vehicle Diagnosis, Testing and Information Systems	281
1.1	Connecting vehicle Diagnosis, Testing and Information System VAS 5051A	281
2	Removing and installing fuse holder	283
2.1	Removing and installing fuse holder on left of dash panel	283
3	Removing and installing relay carrier	285



3.1	Removing and installing relay carrier with safety cut-out on left of dash panel	285
3.2	Removing and installing relay carrier on onboard supply control unit, on left of dash panel	286
4	Electronics boxes	288
4.1	Removing and installing electronics box on left in engine compartment	288
5	Control units	292
5.1	Onboard supply control unit J519	292
5.2	Data bus diagnostic interface J533	294
5.3	Central control unit for convenience system J393	295
5.4	Trailer detector control unit J345	299
6	Wiring harness and connector repairs	302
6.1	Safety instructions	302
6.2	General notes concerning repairs to vehicle electrical system	302
6.3	Notes on repairs to wiring harness and connectors	302
6.4	Supplementary notes on repair of CAN bus wiring	303
6.5	Wiring harness repair set V.A.G 1978	304
7	Renewal of aerial wiring	305
7.1	General description	305
7.2	Assembly overview - an aerial wire	305
7.3	Installing a new aerial wire	305
8	Torque settings: Cables	307
8.1	Torque settings: Electronics box in left side of engine compartment	307
8.2	Torque settings trailer detector control unit J345	307

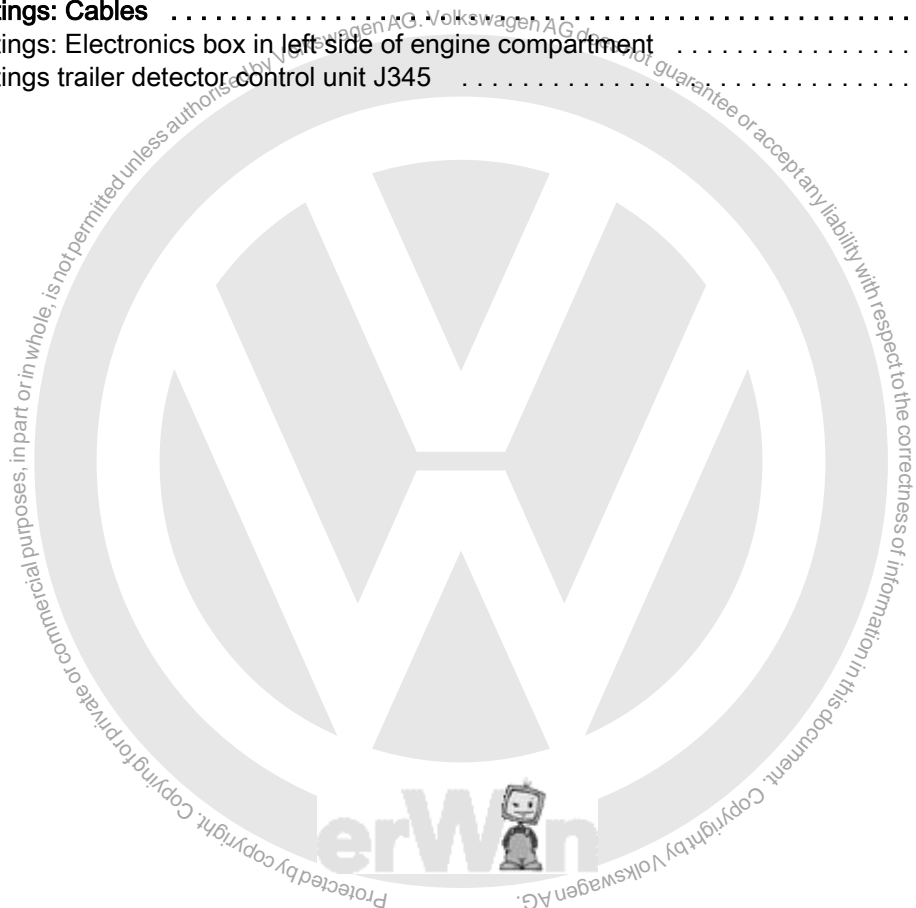





27 – Starter, current supply, CC

1 Battery



WARNING

Danger of injury! Observe warning notices and safety regulations ⇒ [page 2](#)!



Caution

To prevent damage to the battery and vehicle, the following should be observed concerning types of battery ⇒ [page 1](#).

1.1 Fundamentals for batteries

To ensure long use of the battery, the battery must be checked, serviced and maintained as per instructions in this Manual.

Apart from supplying energy for starting the engine, the battery has other tasks: it acts as a buffer and supplies electrical energy to the complete vehicle electrical system.



Note

Observe ⇒ Self-study programme No. 234 ; vehicle batteries .

1.2 Types of battery

1.2.1 Low maintenance battery

Low maintenance battery with liquid electrolyte (wet battery).
These batteries are recognised by the removable cell plugs.

Lead-acid battery, electrolyte level must be checked regularly and topped-up with distilled water as required.

These batteries are often equipped with a magic eye. The magic eye provides information concerning the level of the electrolyte and the charge state of the battery.

1.2.2 Maintenance-free battery

Maintenance-free battery with liquid electrolyte (wet battery).
These batteries have a cover over the cells instead of cell plugs. The cover seals the battery after initial filling during production.



Caution

Never under any circumstances remove the cover for the battery cells. The battery housing will be damaged and the battery is therefore unusable.

Lead-acid battery, where electrolyte need not be topped-up with distilled water under normal conditions. This term is normally used for batteries with a predetermined amount of electrolyte.



These batteries are often equipped with a magic eye. The magic eye provides information concerning the level of the electrolyte and the charge state of the battery.

1.2.3 Absorbent glass mat (AGM) battery

Maintenance-free battery with a contained electrolyte.

Lead-acid battery where the electrolyte is contained within a microscopic glass mat (AGM). The battery is sealed and fitted with valves.

AGM is the abbreviation for Absorbent Glass Mat.



Note

- ◆ *The procedure for checking and testing gel and absorbent glass mat batteries is identical.*
- ◆ *Always replace an absorbent glass mat battery with another absorbent glass mat battery.*

1.2.4 Gel battery

Maintenance-free battery with a contained electrolyte.

Lead-acid battery where the electrolyte is contained within a gel. The battery is sealed and fitted with valves.



Note

- ◆ *The procedure for checking and testing gel and absorbent glass mat batteries is identical.*
- ◆ *Currently gel batteries are only used in motor homes/campers at Volkswagen.*

1.3 Warning notices and safety regulations

1.3.1 Dangers when handling vehicle batteries

Recognition and avoidance of dangers

Batteries can be dangerous. These dangers can be avoided when the warnings on the battery and in the owners/instruction manual and in ELSA are observed.



WARNING

- ◆ *Untrained personal e.g. apprentices, trainees etc. may only work on batteries when supervised by a vehicle mechanic/foreman or vehicle electrician/foreman.*
- ◆ *Acid is highly corrosive. There is a considerable danger of acid burns if personal do not handle batteries correctly. Therefore suitable measures must be taken to ensure that equipment/solutions etc. are available to neutralize acid burns. A suitable solution is: e.g. a soap solution.*
- ◆ *If electrolyte leaks from a battery it may cause skin burns and acid corrosion, rusting on the vehicle. This may damage safety relevant components on the vehicle.*
- ◆ *The gas which forms when charging and the gas which may escape through vent valves is explosive. In extreme cases a battery may explode if the battery is not handled correctly.*
- ◆ *It is prohibited to cause sparks through grinding, welding, cutting operations and use naked lights in the vicinity of batteries. Smoking is also prohibited. Sparks must also be prevented through electrostatic discharge, therefore always earth through vehicle body etc. before touching battery.*
- ◆ *Only work on batteries in well ventilated and suitable rooms.*

1.3.2 Safety markings on battery

Safety markings on battery

1. - Fires, sparks, naked lights and smoking are prohibited. Avoid sparks as well as electrostatic discharge when working with cables and electrical units. Avoid short circuits. Therefore never lay a tool on a battery.
2. - Wear eye protection before commencing work on battery.
3. - Keep children away from acid and batteries.
4. - Disposal: old batteries are classed as hazardous waste. They may only be disposed of through a suitable collection centre and only in accordance with respective legislation.
5. - Never dispose of old batteries in household waste system!
6. - There is a danger of an explosion when working with batteries. A highly explosive gas is produced when batteries are charged.
7. - Follow instructions concerning batteries, in ELSA "electrical system" and in owner's manual.
8. - Battery acid is very caustic, therefore wear eye protection and gloves when working with batteries. Do not tilt battery. Acid can leak out of the gas vents of some batteries.

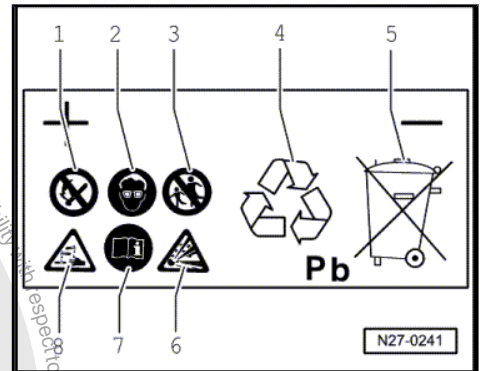



1.4 Battery terminal connection



Caution

To prevent damage to the battery terminal clamps and battery terminals, the following should be observed:

- ◆ *The battery terminal clamps should only be fitted by hand and without using force.*
- ◆ *Battery terminals should not be coated with grease.*
- ◆ *The battery terminal clamps should be fitted so that the battery terminal is either flush with the clamp or protruding from it.*
- ◆ *Once the battery terminal clamps have been tightened to the specified torque, the threaded connections should not be tightened any further.*

The tightening torque for the battery terminal clamps -1- and the additional clamps-2- can be found in this table "Tightening torques: Battery" ⇒ [page 36](#) .

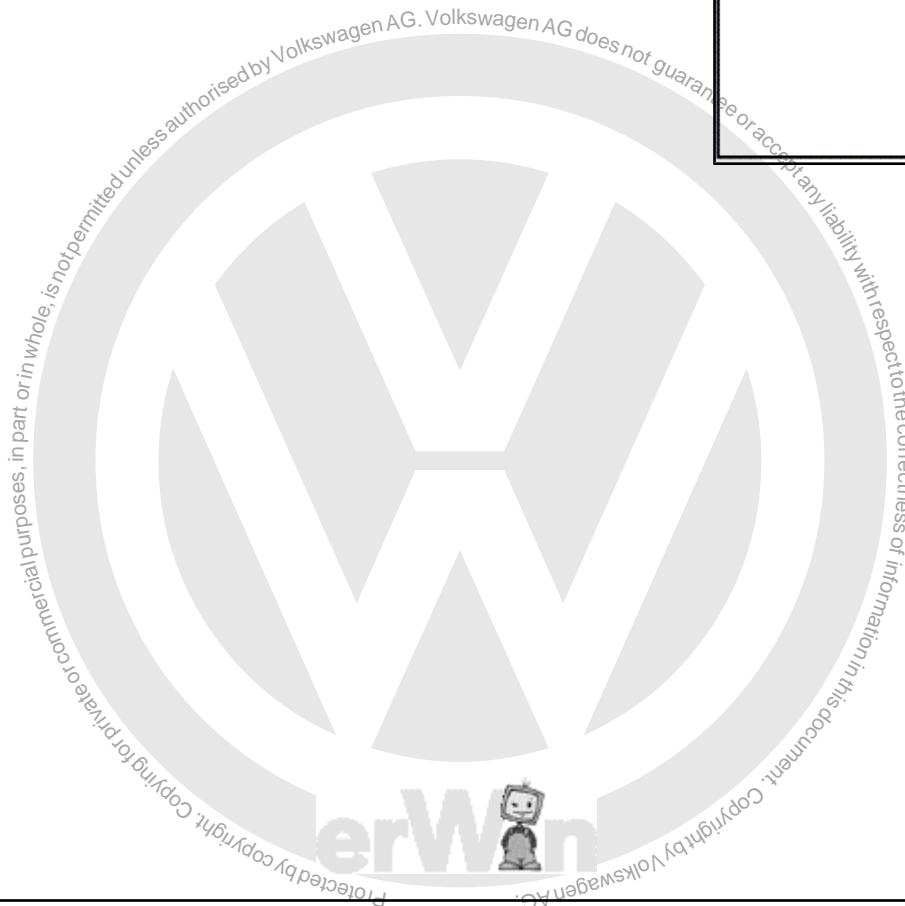
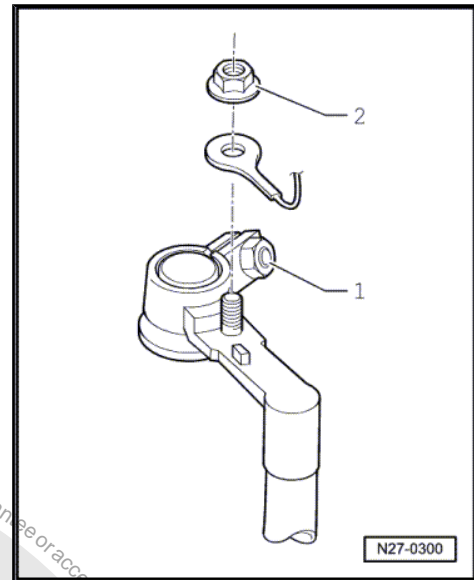



2 Checking battery



WARNING

Danger of injury! Observe warning notices and safety regulations ⇒ page 2!



Caution

To prevent damage to the battery and vehicle, the following should be observed concerning types of battery ⇒ page 1.

2.1 Procedure when checking the battery

Carry out procedure in sequence as follows:

1. Visual check ⇒ page 5 .
2. Checking battery with a magic eye ⇒ page 6 or checking a low maintenance battery ⇒ page 7 .
3. Check no load voltage of battery ⇒ page 10 .
4. Perform a battery load test using battery tester with printer -VAS 5097 A- ⇒ page 12 .

2.2 Visual check



WARNING

Danger of injury! Observe warning notices and safety regulations ⇒ page 2!

It is essential first to check the external condition, the terminals of the battery and that the battery is seated securely visually before performing more extensive tests.



Caution

- ◆ ***The battery will be damaged if the battery is not secured correctly.***
- ◆ ***Vibrations shorten the life of the battery, there is a danger of an explosion, the cell plates may be damaged and the securing plate may damage the battery housing.***
- ◆ ***Check battery is securely seated, if necessary tighten securing bolt to specified torque setting. ⇒ page 36***

- ◆ Whether the battery housing is damaged: Check whether the battery housing is damaged. Electrolyte can leak out if the housing is damaged. If battery acid leaks out, serious damage to the vehicle could be caused. Treat areas of the vehicle affected by leaked battery acid immediately with acid neutraliser or a soap solution.
- ◆ Whether the battery terminals (battery wiring/cable connections) are damaged. Check whether the battery terminals (battery wire connections) are damaged. The necessary contact at the terminal clamps cannot be guaranteed if the terminals are damaged. When connecting clamps to the terminals, tight-



en the clamps to the torque specified in this workshop manual. If the clamps are not correctly seated and tightened, the wiring could burn, which could result in electrical system malfunctions. Which will cause malfunctions in the electrical system. Therefore it can no longer be guaranteed that the vehicle will function correctly.

2.3 Checking battery with magic eye



WARNING

Danger of injury! Observe warning notices and safety regulations ⇒ [page 2](#)!

The magic eye (condition indicator) provides information on the electrolyte level and condition (charge state) of the battery.

Batteries with a magic eye are produced in two versions:

- ◆ Low maintenance ⇒ [page 1](#)
- ◆ Maintenance-free ⇒ [page 1](#)



Note

Because the magic eye is located in only one cell, the display applies only to this cell. An exact determination of battery's condition is only possible through a load test ⇒ [page 12](#).

- Before performing a visual check, tap the magic eye lightly and carefully with the handle of a screwdriver.

The air bubbles, which can influence the display, will dissipate when doing this. The colour display of the magic eye will therefore be more accurate.



Note

- ◆ *Air bubbles can form below the magic eye particularly when the battery is being charged, including during normal vehicle operation. These falsify the colour display of the magic eye.*
- ◆ *The magic eye can be located at various positions on the battery.*

Three different colour displays are possible:

- ◆ “Green”, battery is charged sufficiently.
- ◆ “Black”, Battery partly discharged, charge state < 65 % or completely discharged.
- ◆ “Colourless or yellow”, battery must be renewed.



Note

- ◆ *Charging battery with battery charger -VAS 5095 A- ⇒ [page 15](#).*
- ◆ *Charging battery with battery charger -VAS 5900- ⇒ [page 19](#).*



2.4 Checking low maintenance battery



WARNING

Danger of injury! Observe warning notices and safety regulations => page 2!

This battery is "low maintenance" this means the electrolyte level must be checked and occasionally topped-up with distilled water as required.

2.4.1 Checking electrolyte level of battery

Check electrolyte level on housing:

- Check electrolyte level via -min./ max.- marking on the battery housing.

The electrolyte level is OK when the fluid level is at the max. marking.

If the electrolyte level is below the -max.- marking:

- Replenished with distilled water => page 7 .

Check electrolyte level in the cells:

- Switch off the ignition and all electrical consumers.
- If fitted, remove the protective foil on the cell sealing plug.

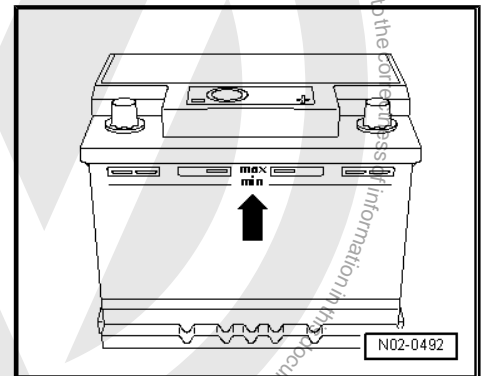

Note

The foil with the warning notices must remain on the battery.

- Remove cell sealing plugs.
- Check the electrolyte level of the battery cells.

The electrolyte level is OK when the fluid level -1- is the same height as the plastic peg.



Note

The plastic peg corresponds to the max. marking.

If electrolyte level is OK:

- Check the cell sealing plugs and the O-ring seals for damage. Damaged parts must be replaced.
- Seal the cells with the cell sealing plugs.

If the electrolyte level is under the plastic peg:

- Replenished with distilled water => page 7 .

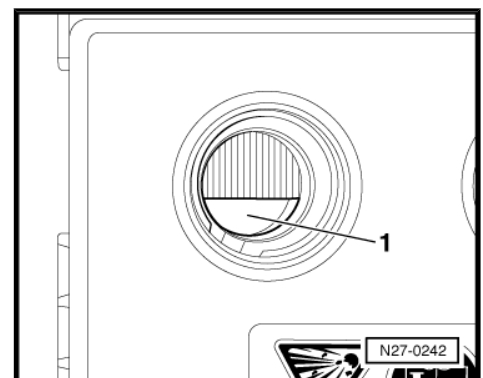

2.4.2 Topping up with distilled water

Special tools and workshop equipment required



◆ Battery filler bottle -VAS 5045/-

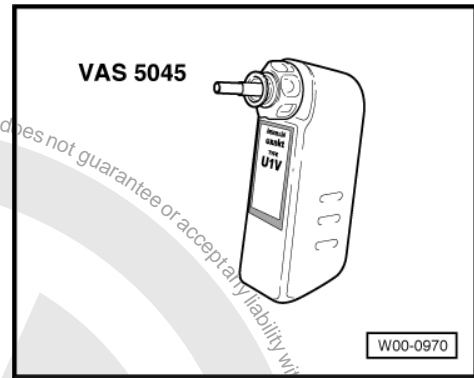

Caution

- ◆ *When filling up with undistilled water or electrolyte the battery will be damaged. Top up with distilled water only.*
- ◆ *The battery may be damaged when the cells are overfilled. When topping up use only the battery filling bottle -VAS 5045/- . The construction of the filler neck prevents an overfilling of the battery cells.*

- Check the electrolyte level of the battery ⇒ [page 7](#) .
- Switch off the ignition and all electrical consumers.
- If fitted, remove the protective foil on the cell sealing plug.



Note

The foil with the warning notices must remain on the battery.

- Remove cell sealing plugs.
- Replenish with distilled water using battery filling bottle -VAS 5045/- . When the max. level is reached the flow is interrupted automatically.
- Check the cell sealing plugs and the O-ring seals for damage. Damaged parts must be replaced.
- Seal the cells with the cell sealing plugs.
- Check no load voltage of battery ⇒ [page 10](#) .
- Perform battery load/discharge test ⇒ [page 12](#) .

2.4.3 Check electrolyte density

Special tools and workshop equipment required



◆ Commercially available hydrometer

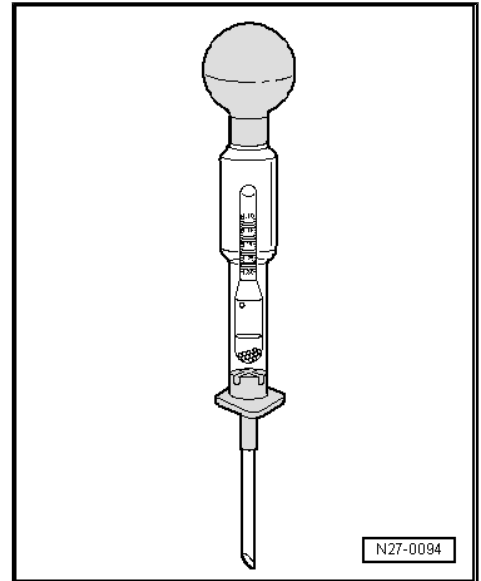

- Check the electrolyte level of the battery ⇒ [page 7](#) .
- Switch off the ignition and all electrical consumers.
- If fitted, remove the protective foil on the cell sealing plug.



Note

The foil with the warning notices must remain on the battery.

- Remove cell sealing plugs.
- Draw electrolyte off a cell using a hydrometer until the float swims unhindered.

The electrolyte density is determined by the float position in the battery electrolyte. The value can be read from the float scale.

Electrolyte density	Charge	Voltage
1,28 g/cm ³	100 %	12,7 V
1,21 g/cm ³	60 %	12,3 V
1,18 g/cm ³	40 %	12,1 V
1,10 g/cm ³	0 %	11,7 V



Note

Checking electrolyte density directly after topping up with distilled water will lead to erroneous results. Check electrolyte density only after charging the battery.

- Check the cell sealing plugs and the O-ring seals for damage. Damaged parts must be replaced.
- Seal the cells with the cell sealing plugs.



2.5 Check no load voltage of battery



WARNING

Danger of injury! Observe warning notices and safety regulations => page 2!

The no load voltage test is used to determine the capacity of the battery.



Note

The battery must not be charged or discharged for at least 2 hours before making the measurements. Charging or discharging during this period falsify the test result.

No load voltage	Charge	Condition of battery
11,70 V	0 %	Discharged, no capacity. Heavily discharged => page 27 .
12,20 V	50 %	Over a period of time sulphate crystals build-up which can only be reversed using a considerable amount of energy. At the same time the active mass expands greatly, which can cause cracks, which leads to heavy corrosion at the positive plate.
12,35 V	65 %	<ul style="list-style-type: none"> ◆ On batteries with a magic eye, the display will change from green to black. ◆ The battery should be recharged on new/vehicles which have been stored.
12.70 V	100 %	Full capacity.

Special tools and workshop equipment required

- ◆ Hand multimeter -V.A.G 1526 B-



- Switch off ignition and all electrical consumers and pull out ignition key.
- Disconnect negative terminal on battery => page 29 .
- Wait at least 2 hours. The battery must not be charged or discharged within this period.
- Check battery no load voltage with hand multimeter -V.A.G 1526 B- .



Measured value	Measure to be performed
No load voltage ≥ 12.5 V	No load voltage is OK, perform a battery load test \Rightarrow page 10 .
No load voltage < 12.5 V	Charge battery \Rightarrow page 15 .

If the battery has been recharged as a result of the no load test, proceed as follows:

- Wait at least 2 hours. The battery must not be charged or discharged within this period.
- Check battery no load voltage again with hand multimeter - V.A.G 1526 B- .

If after the loading process the battery no load voltage is < 12.5 V, renew battery \Rightarrow [page 31](#) .

2.6 Battery tester with printer -VAS 5097 A-



WARNING

Danger of injury! Observe warning notices and safety regulations \Rightarrow [page 2](#) !

It is not necessary to remove or disconnect battery when using battery tester with printer -VAS 5097 A- .

Battery tester with battery tester with printer -VAS 5097 A- can be used to test 12 V starter batteries according to

- ◆ 80 - 499 A A low-temperature test current according to DIN (Deutsche Industrie Norm (German Industrial Standard))¹⁾
- ◆ 95 - 574 A A low-temperature test current according to IEC (International Engineering Consortium)
- ◆ 136 - 855 A A low-temperature test current according to EN/SAE (European Norm/Standard of Automotive Engineers)

1) Batteries with a low-temperature test current of 520 A according to DIN can be tested using setting for 499A according to DIN.

For test purposes the battery is loaded with a current which is similar to the starting current required to start the vehicle. The battery is assessed on this loading and the result is printed out.



Note

- ◆ *Observe the \Rightarrow Instruction Manual for battery tester with printer -VAS 5097 A- or sticker \Rightarrow Brief instructions for battery tester with printer -VAS 5097 A- stuck on the unit or table Low-temperature current. \Rightarrow [page 13](#)*
- ◆ *Observe battery manufacture's handling instructions!*



2.6.1 Description of battery tester with printer -VAS 5097 A-

Battery tester with printer -VAS 5097 A-

- 1 - Green LED, "unit operating"
- 2 - Red LED, "unit reverse-polarity connected"
- 3 - Red LED, "battery cannot be tested", recharge battery.
- 4 - Start tester
- 5 - Low-temperature current selection switch
- 6 - ON/OFF and functions switch
- 7 - Selection switch (battery tester to pick-off point on battery/
external test point in engine compartment)
- 8 - Button to advance paper
- 9 - Printer

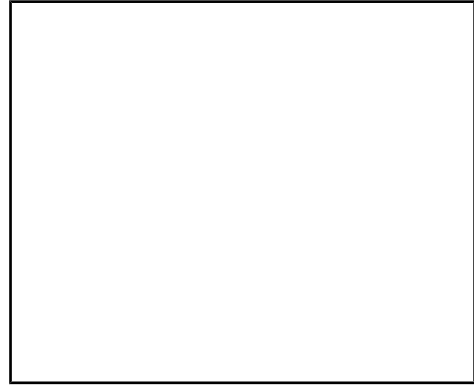

2.6.2 Battery load test using battery tester with printer -VAS 5097 A-



WARNING

Danger of injury! Observe warning notices and safety regulations ⇒ [page 2](#)!

Special tools and workshop equipment required

- ◆ Battery tester with printer -VAS 5097 A-

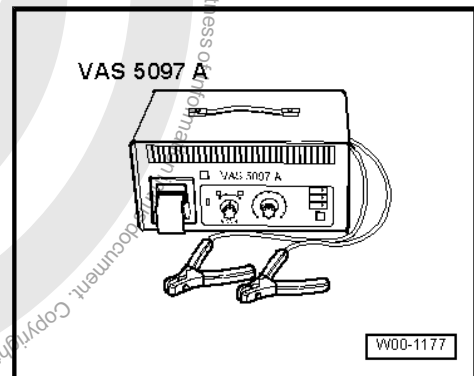

Perform battery load test:

- Switch off the ignition and all electrical consumers.
- Check no load voltage of battery ⇒ [page 10](#) .
- Set low-temperature test current for battery in Ampere (A) according to DIN standard.

If the battery values are shown in IEC or EN/ SAE instead of DIN then convert figures using table
⇒ "[2.6.3 Table: low-temperature test current](#)", [page 13](#) or using table on unit.

- Select low-temperature test current via low-temperature test current selection switch ⇒ [page 12](#) .
- Select measuring range 80 - 379 A or 380 - 499 A with ON/OFF and functions switch ⇒ [page 12](#) .
- Connect red terminal "+" of unit to positive terminal.



- Connect black terminal “-” of unit to negative terminal.



Note

Ensure test clamps have a good contact!

- Select point of connection of test terminals with selection switch ⇒ [page 12](#) .
 - 1 - Connected directly to battery.
 - 2 - Connected to external test points in engine compartment.
 - Check that the figures given on the battery are correct for the settings on the battery tester.
 - Press start test button ⇒ [page 12](#) .
- The green LED lights up ⇒ [page 12](#) . The test program runs through automatically. The test result is printed out by the printer ⇒ [page 14](#) .
- Switch off unit ⇒ [page 12](#) .
 - Remove test terminals.



Note

- ◆ *The test is completed after about 20 seconds.*
- ◆ *The result of the test is printed out by the printer.*
- ◆ *Perform test once only. Repeating the test falsifies the results.*

2.6.3 Table: low-temperature test current

Low-temperature test current in A			
EN/ SAE	IEC	→	DIN
136 - 17	95 - 124	→	80 - 104
178 - 219	125 - 154	→	105 - 129
220 - 261	155 - 184	→	130 - 154
262 - 303	185 - 214	→	155 - 179
304 - 345	215 - 244	→	180 - 204
346 - 387	245 - 274	→	204 - 229
388 - 429	275 - 304	→	230 - 254
430 - 471	305 - 334	→	255 - 279
472 - 513	335 - 364	→	280 - 304
514 - 555	365 - 394	→	305 - 329
556 - 597	395 - 424	→	330 - 354
598 - 639	425 - 454	→	355 - 379
640 - 657	455 - 464	→	380 - 389
658 - 675	465 - 474	→	390 - 399
676 - 693	475 - 484	→	400 - 409
694 - 711	485 - 494	→	410 - 419
712 - 729	495 - 504	→	420 - 429
730 - 747	505 - 514	→	430 - 439
748 - 765	515 - 524	→	440 - 449
766 - 783	525 - 534	→	450 - 459
784 - 801	535 - 544	→	460 - 469



Low-temperature test current in A			
EN/ SAE	IEC	⇒	DIN
802 - 819	545 - 554	⇒	470 - 479
820 - 837	555 - 564	⇒	480 - 489
838 - 855	565 - 574	⇒	490 - 499 ²⁾

2) Batteries with a low-temperature test current of 520 A according to DIN can be tested using setting for 499A according to DIN.

2.7 Evaluating test result

Because of the high load on the battery during this test (a high current flows) the battery voltage drops.

- ◆ If the battery is OK the voltage value only lowers to the minimum voltage.
- ◆ If the battery is defective or has a low charge the battery voltage quickly drops below the minimum voltage.
- ◆ This low voltage value remains over a long period and the voltage only increases again slowly after the test has been completed.
- ◆ Perform test once only. Repeating the test falsifies the results.

2.7.1 Comments concerning test print out

- 1 - Measuring range set on tester.
- 2 - Diagram -arrow- indicates battery condition.
- 3 - Test result.
- 4 - Battery voltage during load test.
- 5 - Vehicle data and date. Must be completed by test personnel.



Note

- ◆ The print out is required for warranty purposes.
- ◆ Perform test once only. Repeating the test falsifies the results.

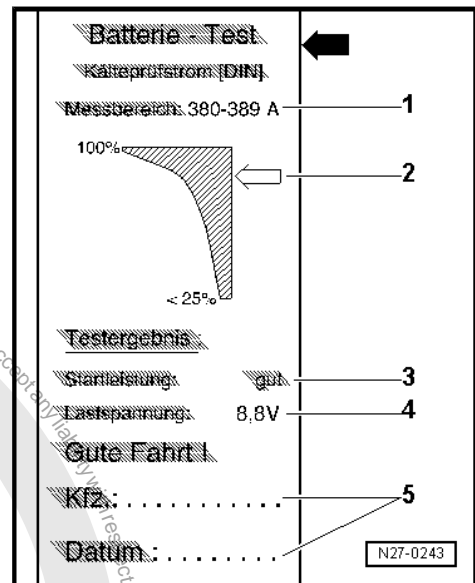

2.7.2 Assessing test results

Battery tester print out	Measure to be performed
Starting power very good	Battery OK
Start output good	Battery OK
Starting power sufficient	Charge battery ⇒ page 15 and repeat battery load test ³⁾
Starting power poor	
Starting power very poor	
Not capable of being tested	

3) If after battery has been recharged "Starting output sufficient", "Starting output poor", "Starting output very poor" or "Cannot be tested" is shown, the battery should be renewed.



3 Charging battery

WARNING

Danger of injury! Observe warning notices and safety regulations => [page 2](#)!

Caution

To prevent damage to the battery and vehicle, the following should be observed concerning types of battery => [page 1](#) .

3.1 Battery charger -VAS 5095 A-

This chapter describes the basic functions of the battery charger -VAS 5095 A-. For additional information refer to => Operating instructions for battery charger -VAS 5095 A- .

Note

- ◆ Observe => Operating instructions for battery charger -VAS 5095 A- .
- ◆ Observe battery manufacture's handling instructions!

3.1.1 Description of battery charger -VAS 5095 A-

Battery charger -VAS 5095- is suitable for charging

- ◆ Wet batteries (genuine VW batteries from 2004 with transparent battery housing and black cover).
- ◆ Absorbent glass mat batteries (genuine VW batteries from 2004 with black housing).

The battery charger charges without peaks in amperage or voltage. This will not adversely effect the onboard electronics. The battery can remain in the vehicle while it is being charged and need not be disconnected.

Battery charger -VAS 5095 A-

- 1 - ON / OFF switch (0 = charger OFF)
- 2 - Charging current indicator (I > 12 A)
- 3 - Charging current indicator, battery partially charged > 90 %
- 4 - Maintaining charge, lights up green when battery is fully charged
- 5 - Malfunction indicator
- 6 - Support mode indicator
- 7 - Support mode/normal mode changer-over switch
- 8 - Charger cable posts, red terminal "+", black terminal "-"
- 9 - Battery type change-over switch (on base of charger unit)

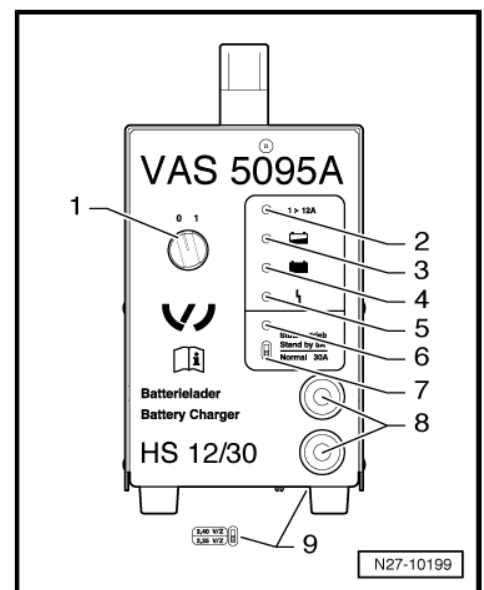



3.1.2 Charging battery with battery charger - VAS 5095 A-



WARNING

Danger of injury! Observe warning notices and safety regulations ⇒ [page 2](#)!

Special tools and workshop equipment required

- ◆ Battery charger -VAS 5095 A-

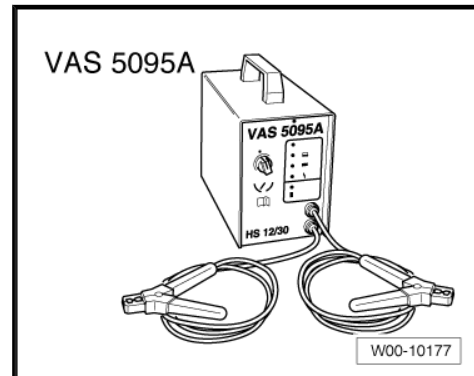

Caution

*Always set battery type 2.4 V/C (Volt/Cells) when charging!
This applies for all batteries.*



Note

- ◆ *The battery must have a temperature of at least 10 °C.*
- ◆ *If the battery has cell sealing plugs, do not open them while the battery is being charged.*
- Switch off the ignition and all electrical consumers.
- Check setting for battery type on type of battery switch ⇒ [page 15](#) . Must be set to 2.4 V/C (Volt/Cells).
- Connect red terminal clamp “+” of charger unit to positive terminal on battery.
- Connect black terminal clamp “-” of charger unit to negative terminal on battery.
- Switch on battery charger ⇒ [page 15](#) .

The charging current indicators ⇒ [page 15](#) -2- and -3- light up yellow. When only the light emitting diode (LED) -3- lights up yellow, battery is partially discharged (approx. 90 %).

If the LED lights up green ⇒ [page 15](#) -4- the charger has switched to "maintaining charge". The battery is fully charged.

- Switch off charging unit ⇒ [page 15](#) .
- Remove charger unit terminals from battery terminals.



3.1.3 Charging totally discharged battery with battery charger -VAS 5095 A-



WARNING

Danger of injury! Observe warning notices and safety regulations => page 2!

The charger unit automatically recognises totally discharged batteries and initiates a gentle charging procedure with a low charging current. The charging current is automatically adapted to suit the charge condition of the battery.



Note

- ◆ Observe notes in chapter => [page 27](#) .
- ◆ The battery voltage must be at least 0.6 V.
- Charge battery => [page 16](#) .

3.1.4 Charging battery in support mode with battery charger -VAS 5095 A-



WARNING

Danger of injury! Observe warning notices and safety regulations => page 2!

When in support mode the battery charger -VAS 5095 A- replaces a defective vehicle battery whilst it is being exchanged. The on-board supply remains intact. The vehicles electrical equipment (e.g. electric windows) can be used.

Special tools and workshop equipment required

- ◆ Battery charger -VAS 5095 A-

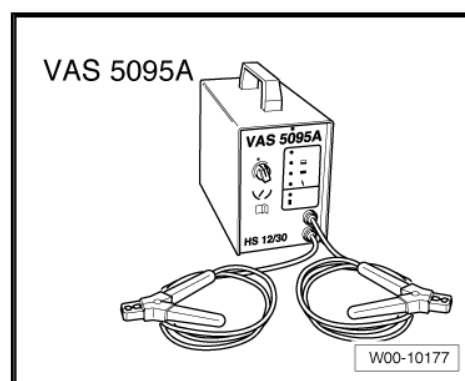

Caution

- ◆ ***Always set battery type 2.4 V/C (Volt/Cells) when in support mode! This applies for all batteries.***
- ◆ ***The battery charger -VAS 5095 A- terminal clamps must remain in contact with the battery terminal clamps whilst the battery is being exchanged.***



- Switch off the ignition and all electrical consumers.
- Set support mode/normal mode change-over switch to [⇒ page 15](#) "support mode".
- Connect red terminal clamp "+" of charger unit to positive terminal of vehicle.
- Connect black terminal clamp "-" of charger unit to negative terminal of vehicle.
- Check setting for battery type on type of battery switch [⇒ page 15](#) . Must be set to 2.4 V/C (Volt/Cells).
- Switch on battery charger [⇒ page 15](#) .

The yellow LEDs [⇒ page 15](#) -6- and -3- light up.



Note

- ◆ *A minimum load of 0.6 A (e.g. parking light) must be switched on, otherwise support mode is not possible.*
- ◆ *During the support mode the current draw is limited to 5 A.*
- Switch on vehicle parking light.
- Exchange battery [⇒ page 31](#) .
- Switch off charging unit [⇒ page 15](#) .
- Remove charger unit terminals from battery terminals.
- Set support mode/normal mode change-over switch to [⇒ page 15](#) "normal mode" again.

3.1.5 Charging battery in buffer/ maintenance mode with battery charger -VAS 5095 A-



WARNING

Danger of injury! Observe warning notices and safety regulations [⇒ page 2](#) !

In the buffer mode the battery charger -VAS 5095 A- is charged correctly and is maintained in a fully charged condition.

- Proceed as for charging battery [⇒ page 16](#) .



Note

- ◆ *When a battery is being charged in the buffer mode and a consumer draws current from the battery, the battery charger -VAS 5095 A- automatically compensates the charge.*
- ◆ *The buffer mode can be continued for an unlimited period.*
- ◆ *The battery is always ready for use.*
- ◆ *Observe battery manufacture's maintenance instructions!*



3.2 Battery charger -VAS 5900-



WARNING

Danger of injury! Observe warning notices and safety regulations ⇒ page 2!

This chapter describes the basic functions of the battery charger -VAS 5900-. For additional information refer to ⇒ Operating instructions for battery charger -VAS 5900- .



Note

- ◆ Observe ⇒ Operating instructions for battery charger -VAS 5900- .
- ◆ Observe battery manufacture's handling instructions!

3.2.1 Description of battery charger -VAS 5900-

Battery charger -VAS 5900- is suitable for charging

- ◆ Wet batteries (genuine VW batteries from 2004 with transparent battery housing and black cover).
- ◆ Absorbent glass mat batteries (genuine VW batteries from 2004 with black housing).

Battery charger -VAS 5900-

- 1 - Display
- 2 - Adjustment button "Up"
- 3 - Adjustment button "Down"
- 4 - **START / STOP**
- 5 - **INFO**

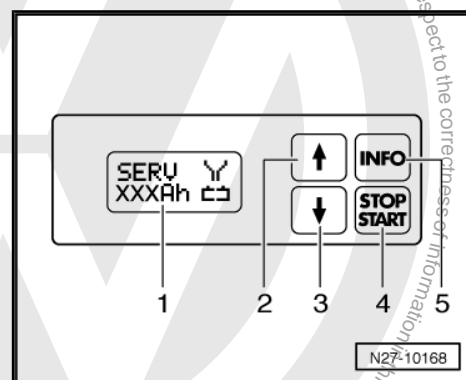

3.2.2 Charging battery with battery charger -VAS 5900-



WARNING

Danger of injury! Observe warning notices and safety regulations ⇒ page 2!

Special tools and workshop equipment required



◆ Battery charger -VAS 5900-

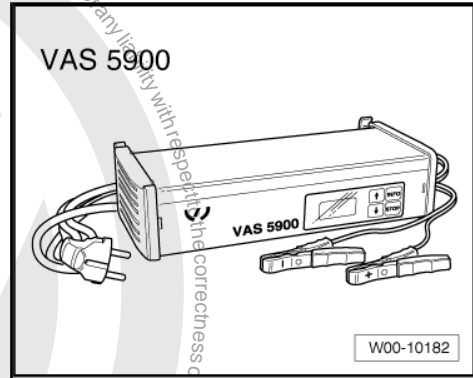

Note

- ◆ *The battery must have a temperature of at least 10 °C.*
- ◆ *If the battery has cell sealing plugs, do not open them while the battery is being charged.*
- Switch off the ignition and all electrical consumers.
- Connect charger unit plug to power supply. The last selected operating mode will appear on display ⇒ [page 19](#).
- Set battery to respective operating mode with **INFO**.

In the display the symbol -1- for “standard charge for wet batteries” or the symbol -2- for “standard charge for gel/absorbent glass mat batteries” will appear.

- Set battery capacity (Ah) of battery for charging using respective button “Up” or “Down” .
- Connect red terminal clamp “+” to positive terminal on battery.
- Connect black terminal clamp “-” to negative terminal on battery.

The charger unit recognises the voltage required for the connected battery (6 V, 12 V or 24 V) and initiates the charging sequence.

At a charge condition of approx. 80 - 85 % the charger unit switches to the “final charge” mode. The fourth bar appears in display -1-. The battery is ready for use.

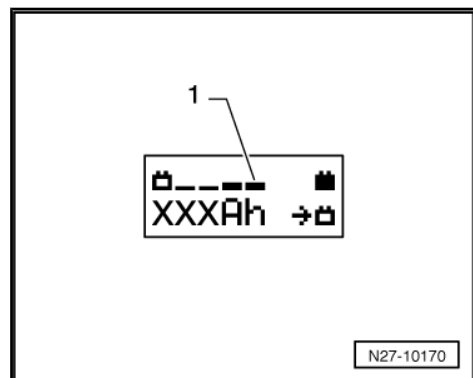
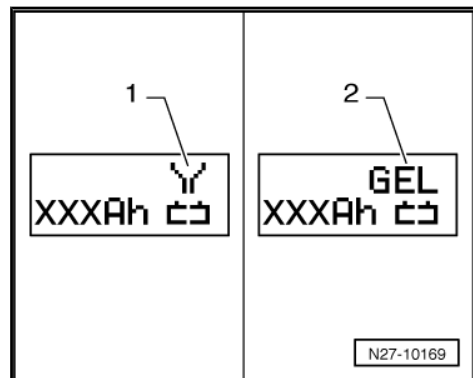





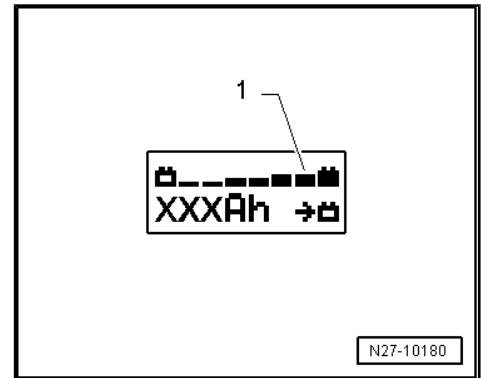

At a charge condition of 100 % all bars appear in display.

 **Note**

- ◆ In the battery type “standard charge” the parallel use of consumers while charging is possible. The charging period will be longer.
- ◆ The battery charger will switch to maintenance mode after about 1-7 hours, depending on type of battery. To achieve a 100 % charge the battery should remain connected for this period.



Possible faults and fault rectification:

- 1 - Displayed battery voltage is not as per nominal voltage:
 - Press respective button “Up”  or “Down”  until charging sequence starts.
- 2 - Displayed battery voltage is not as per nominal voltage – charging sequence already started:
 - Press **START / STOP** twice.
 - Press respective button “Up”  or “Down”  until charging sequence starts again.
- 3 - Battery charger does not detect a battery, when battery voltage is less than 2 V:

Display remains unchanged.

The battery type and ampere hours (Ah) as set is displayed.

Ending battery charging sequence:

- Press **START / STOP**.
- Disconnect black terminal clamp “-” of charger unit from negative terminal on battery.
- Disconnect red terminal clamp “+” of charger unit from negative terminal on battery.
- Pull charger unit plug out power supply socket.

3.2.3 Charging battery in service mode with battery charger -VAS 5900-

 **WARNING**

Danger of injury! Observe warning notices and safety regulations => page 2!

 **Caution**

The operating mode “service charge” is not permitted on VW vehicles as the voltage peaks will damage the onboard electronics.

If there is a requirement to use “service charge” the battery must be disconnected from the onboard supply.



Caution

When charging always set the battery charger to the correct type of battery ⇒ Operating instructions for battery charger - VAS 5900-!

“Service charge” must only be used for:

- ◆ **Wet batteries, where distilled water can be replenished.**
- ◆ **Gel/absorbent glass mat batteries.**

Do not use operating mode “service charge” with maintenance-free wet batteries ⇒ [page 1](#) .

The operating mode “service charge (SERV)” is only used on suspect defective batteries (e.g. sulphation). The battery will be charged to maximum specific gravity and the plates will be reactivated (dissipation of sulphur layer).

Special tools and workshop equipment required

- ◆ Battery charger -VAS 5900-

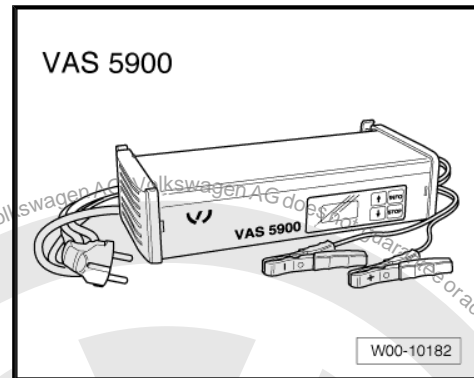

Note

- ◆ **The battery must have a temperature of at least 10 °C.**
- ◆ **If the battery has cell sealing plugs, do not open them while the battery is being charged.**
- Switch off the ignition and all electrical consumers.
- Connect charger unit plug to power supply. The last selected operating mode will appear on display ⇒ [page 19](#) .
- Set battery to respective operating mode with **INFO**.

In the display the symbol -1- for “service charge for wet batteries” or the symbol -2- for “service charge for gel/absorbent glass mat batteries” will appear.

- Set battery capacity (Ah) of battery for charging using respective button “Up” or “Down” .
- Connect red terminal clamp “+” to positive terminal on battery.
- Connect black terminal clamp “-” to negative terminal on battery.

The charger unit recognises the voltage required for the connected battery (6 V, 12 V or 24 V) and initiates the charging sequence.

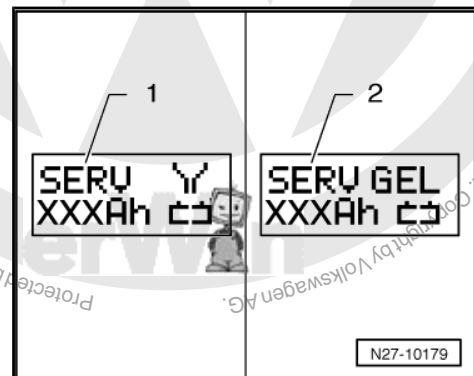







At a charge condition of approx. 80 - 85 % the charger unit switches to the "final charge" mode. The fourth bar appears in display -1-. The battery is ready for use.

 **Note**

The success of the "service charge" depends on the severity of the sulphation of the battery.

Possible faults and fault rectification:

- 1 - Displayed battery voltage is not as per nominal voltage:
 - Press respective button "Up"  or "Down"  until charging sequence starts.
- 2 - Displayed battery voltage is not as per nominal voltage – charging sequence already started:
 - Press **START / STOP** twice.
 - Press respective button "Up"  or "Down"  until charging sequence starts.
- 3 - Battery charger does not detect a battery, when battery voltage is less than 2 V:

Display remains unchanged.

The operating mode and ampere hours (Ah) as set is displayed.

Ending battery charging sequence:

- Press **START / STOP**.
- Disconnect black terminal clamp "-" of charger unit from negative terminal on battery.
- Disconnect red terminal clamp "+" of charger unit from negative terminal on battery.
- Pull charger unit plug out power supply socket.

3.2.4 Charging totally discharged battery with battery charger -VAS 5900-

 **WARNING**

Danger of injury! Observe warning notices and safety regulations => page 2!

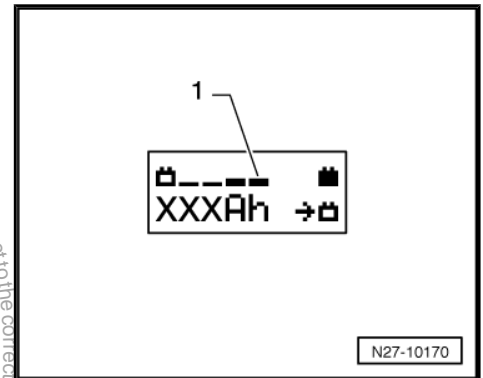



Caution

- ◆ *The terminal polarity protection in operating mode "charging totally discharged batteries/support mode" is not active. Connect battery charger terminal clamps correctly to battery terminals.*
- ◆ *When charging always set the battery charger to the correct type of battery ⇒ Operating instructions for battery charger -VAS 5900- !*
- ◆ *Totally discharged battery is not recognised by battery charger ⇒ [page 27](#) .*
- ◆ *Do not press **START / STOP** button when charger unit cables are connected incorrectly. The charger unit may be damaged.*

Batteries with a voltage of less than 2 Volt will not be recognised automatically by battery charger -VAS 5900- .

Special tools and workshop equipment required

- ◆ Battery charger -VAS 5900-

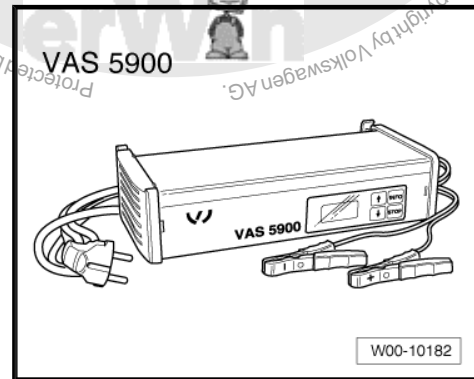

Note

- ◆ *The battery must have a temperature of at least 10 °C.*
- ◆ *If the battery has cell sealing plugs, do not open them while the battery is being charged.*
- Switch off the ignition and all electrical consumers.
- Connect charger unit plug to power supply. The last selected operating mode will appear on display ⇒ [page 19](#) .



- Set battery to respective operating mode with **INFO**.

In the display the symbol -1- for “service charge for wet batteries” or the symbol -2- for “service charge for gel/absorbent glass mat batteries” will appear.

- Set battery capacity (Ah) of battery for charging using respective button “Up” or “Down” .
- Connect red terminal clamp “+” to positive terminal on battery.
- Connect black terminal clamp “-” to negative terminal on battery.
- Press **START / STOP** for approx. 5 seconds. The menu “charging totally discharged batteries/support mode” will be activated.
- Press respective button “Up” or “Down” to set the respective battery voltage (6 V, 12 V or 24 V).

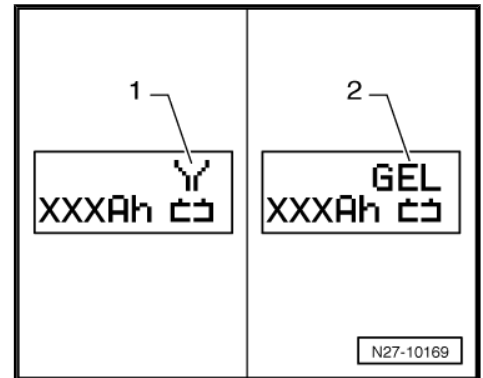

Note

If a button is not pressed within 5 seconds the charger will return to the main menu (select operating mode).

- Confirm the selected battery voltage with **START / STOP**.

Then follows the enquiry for “is charger cable terminal polarity correct”.

- Check polarity of charger unit cables.
- Confirm polarity of charger unit cables with **START / STOP**.

Charger will start charging sequence for totally discharged battery.

Ending battery charging sequence:

- Press **START / STOP**.
- Disconnect black terminal clamp “-” of charger unit from negative terminal on battery.
- Disconnect red terminal clamp “+” of charger unit from negative terminal on battery.
- Pull charger unit plug out power supply socket.

3.2.5 Charging battery in support mode with battery charger -VAS 5900-



WARNING

Danger of injury! Observe warning notices and safety regulations => page 2!



Caution



- ◆ *The terminal polarity protection in operating mode "charging totally discharged batteries/support mode" is not active. Connect battery charger terminal clamps correctly to battery terminals.*
- ◆ *When charging in support mode always set the battery charger to the correct type of battery ⇒ Operating instructions for battery charger -VAS 5900- !*
- ◆ *Do not press **START / STOP** button when charger unit cables are connected incorrectly. The charger unit may be damaged.*

When in support mode the battery charger -VAS 5900- replaces a defective vehicle battery whilst it is being exchanged. The on-board supply remains intact. The vehicles electrical equipment (e.g. electric windows) can be used.

Special tools and workshop equipment required

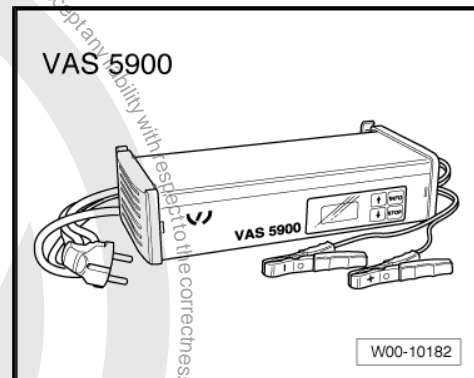
- ◆ Battery charger -VAS 5900-



- Switch off the ignition and all electrical consumers.
- Connect charger unit plug to power supply. The last selected operating mode will appear on display ⇒ [page 19](#) .
- Press **START / STOP** for approx. 5 seconds. The menu "charging totally discharged batteries/support mode" will be activated.
- Press respective button "Up"  or "Down"  to set the respective onboard supply voltage (6 V, 12 V or 24 V).



Note

If a button is not pressed within 5 seconds the charger will return to the main menu (select operating mode).

- Confirm the selected battery voltage with **START / STOP**.
- Connect red terminal clamp "+" of charger unit to positive terminal of vehicle.
- Connect black terminal clamp "-" of charger unit to negative terminal of vehicle.

Then follows the enquiry for "is charger cable terminal polarity correct".

- Check polarity of charger unit cables.
- Confirm polarity of charger unit cables with **START / STOP**.



The battery charger starts with support mode.

- Exchange battery ⇒ [page 31](#) .
- Press **START / STOP**. The support mode is terminated.
- Disconnect black terminal clamp “-” of charger unit from negative terminal of vehicle.
- Disconnect red terminal clamp “+” of charger unit from positive terminal of vehicle.
- Pull charger unit plug out power supply socket.

3.2.6 Charging battery in maintenance mode with battery charger -VAS 5900-



WARNING

Danger of injury! Observe warning notices and safety regulations ⇒ [page 2](#)!

When the battery is fully charged the battery charger -VAS 5900- switches to maintenance mode.

- Proceed as for charging battery ⇒ [page 19](#) .

At a charge condition of 100 % all bars appear in display.

Note

- ◆ *When a battery is being charged in the buffer mode and a consumer draws current from the battery, the battery charger -VAS 5900- automatically compensates the charge.*
- ◆ *The maintenance mode can be continued for an unlimited period.*
- ◆ *The battery is always ready for use.*
- ◆ *Observe battery manufacture's maintenance instructions!*

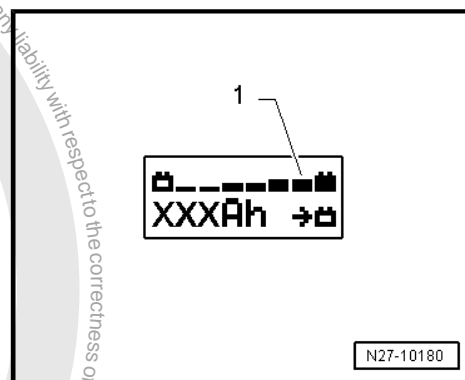

3.3 Totally discharged batteries



WARNING

Danger of injury! Observe warning notices and safety regulations ⇒ [page 2](#)!

A battery is designated “totally discharged” when the “no load” voltage is less than 12.2 V.



Caution

- ◆ *Totally discharged batteries freeze prematurely.*
- ◆ *Frozen batteries should no longer be used.*



Note

- ◆ *Batteries that have not been used for a long time e.g. vehicles that have been stored, will self-discharge.*
 - ◆ *In totally discharged batteries, the electrolyte is comprised almost entirely of water because the acid content is so low.*
 - ◆ *Totally discharged batteries sulphate, that is, the entire plate surfaces of the battery harden.*
 - ◆ *If a battery is recharged shortly after it has totally lost its charge, the sulphation will dissipate.*
 - ◆ *If these batteries are not recharged the plates continue to harden and the ability to recharge is reduced. A reduction in the battery output is the result.*
- Check no load voltage of battery ⇒ [page 15](#) .
 - Charge battery.
- Charging battery with battery charger -VAS 5095 A- ⇒ [page 15](#) .
- Charging battery with battery charger -VAS 5900- ⇒ [page 19](#) .





4 Disconnecting and reconnecting batteries



WARNING

Danger of injury! Observe warning notices and safety regulations => page 2!

4.1 Disconnecting battery



Note

- ◆ *By disconnecting the battery earth wire (open circuit), safety is ensured when carrying out work on the electrical system.*
- ◆ *The battery positive wire need only be disconnected for removal of the battery.*

- Switch off the ignition and all electrical consumers.
- Release catch -arrow- and take cover off battery box.
- First unscrew battery earth clamp -1- from battery negative terminal.

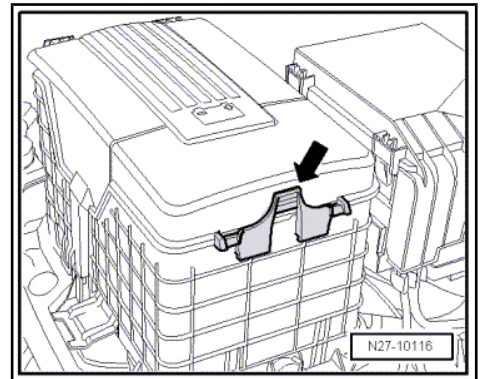

- Then unscrew battery positive clamp -2- from battery positive terminal.

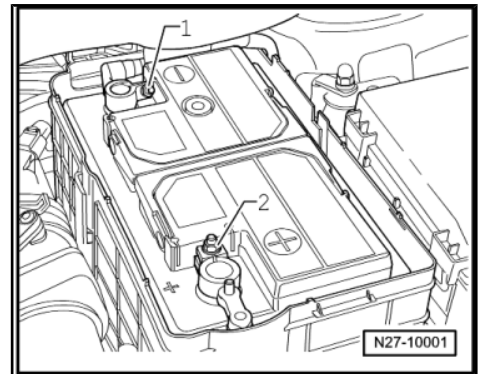

4.2 Connecting battery



Caution

Observe instructions on connecting battery terminals => page 4.

Special tools and workshop equipment required



◆ Torque wrench -V.A.G 1331-

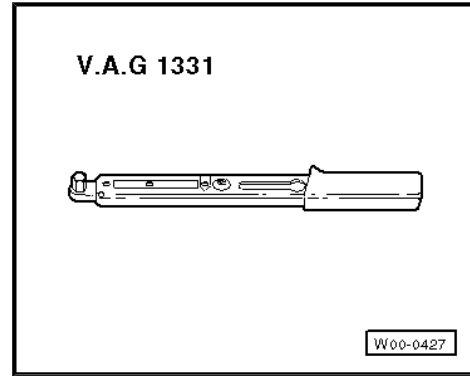

i Note

After connecting the battery and switching the ignition on the ESP and TCS warning lamp -K155- lights up permanently. The warning lamp goes out automatically if a distance of 15 to 20 km/h is driven straight ahead. This activates the steering angle sender -G85- again.

⚠ Caution

Disconnecting and connecting the battery as described in the Workshop Manual ⇒ [page 29](#)

- Fit battery positive clamp -2- to positive terminal of battery and tighten securing bolt to specified torque setting ⇒ [page 36](#) .
- Fit battery earth clamp -1- to negative terminal of battery and tighten securing bolt to specified torque setting ⇒ [page 36](#) .
- Carry out the procedures as detailed in the table.

Steps after connecting battery

Procedures	Performed
Switch ignition on and off again using ignition key	
Read fault memory: ⇒ Guided fault finding using VAS 5051A .	
Clock: Check time on clock and change as necessary.	
Electric windows: Open all electric windows fully and close again.	
Functional check: of all electrical consumers.	

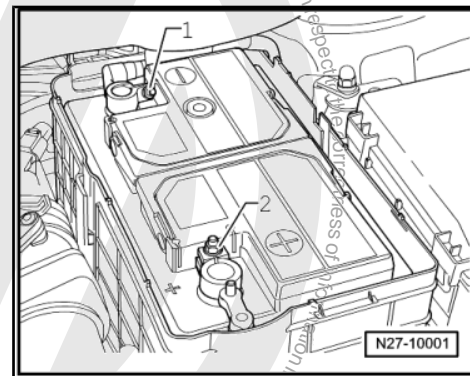

If necessary, table can be printed out.



5 Removing and installing battery



WARNING

Danger of injury! Observe warning notices and safety regulations ⇒ [page 2](#)!

5.1 Models with a petrol engine

Special tools and workshop equipment required

- ◆ Torque wrench -V.A.G 1331-

V.A.G 1331



W00-0427

Removing:

- Disconnect the battery ⇒ [page 29](#) .
- Pull panel of battery box out upwards in direction of arrow.

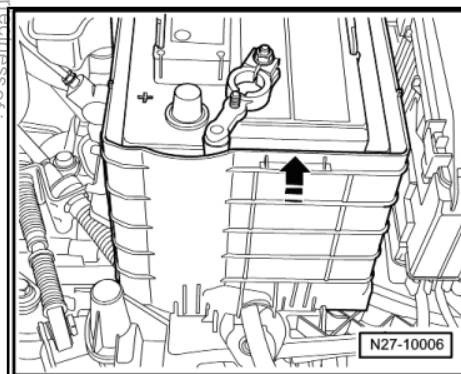

- Unscrew securing bolt -1- and remove battery holder -2-.

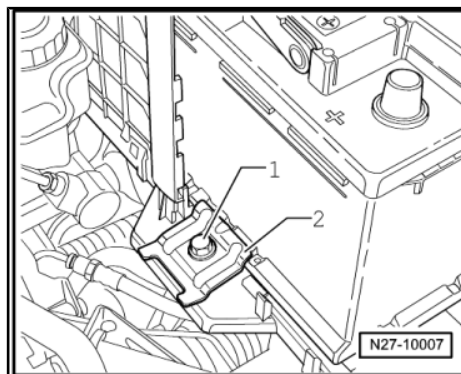



- Fold handles -arrows- upwards and take battery out.

Installing:



Caution

A loosely fitted battery creates the following dangers:

- ◆ *Shortened service life due to damage from vibration (danger of explosion).*
- ◆ *The cells in the battery will be damaged if the battery is not secured correctly.*
- ◆ *Damage to battery housing by clamping bracket (possibility of acid leaking, therefore subsequent higher costs).*
- ◆ *Poor crash safety*

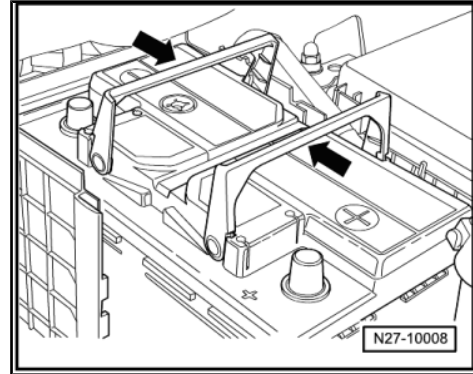

Installation is performed in the reverse order of installation; when doing this, note the following:

- Tighten threaded connections to specified torque settings => [page 36](#) .
- After installing, check that battery is seated securely.
- Connect the battery => [page 29](#) .



Caution

Disconnecting and connecting the battery as described in the Workshop Manual => [page 29](#) .

5.2 Models with a diesel engine

Special tools and workshop equipment required

- ◆ Torque wrench -V.A.G 1331-

V.A.G 1331



W00-0427



◆ Spring-type clip pliers -VAS 5024A-

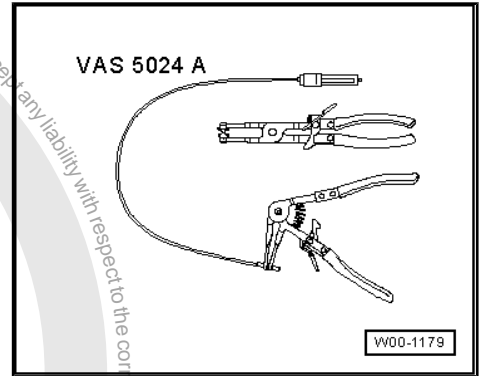

Removing:

- Disconnect the battery => [page 29](#) .

For vehicles with a 1.9 l TDI engine:

- Pull engine cover upwards -arrows A- and forwards -arrow B-.

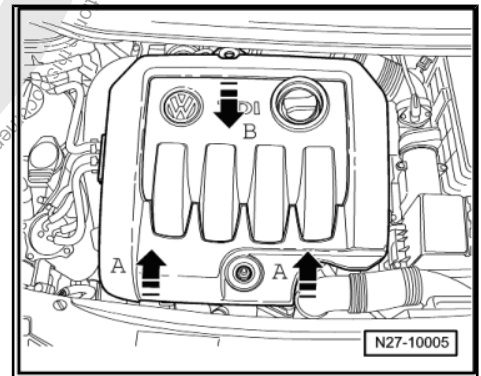

- Disconnect connector -1- and loosen spring type clip -2- with spring type clip pliers -VAS 5024A- .

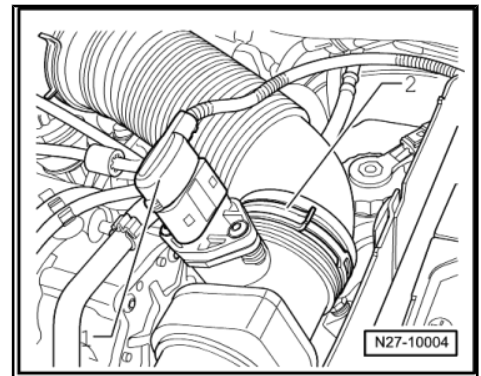

- Pull the vacuum hose -arrow- off air filter housing.

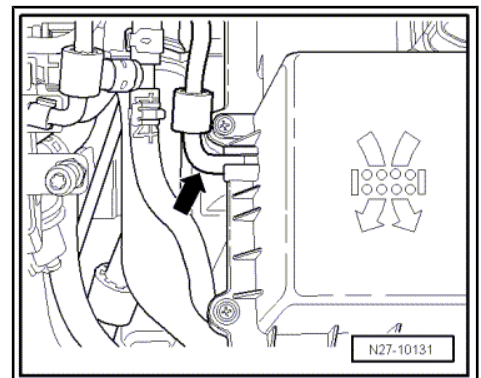



- Unscrew air filter housing securing bolt -arrow-.

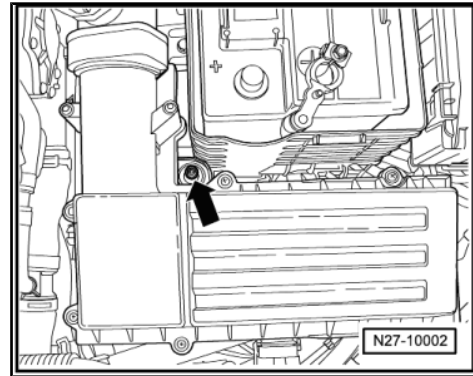

- Unlock lugs -arrows- and take cover off.

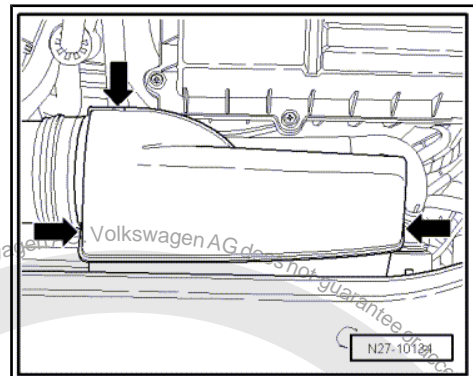

- Pull hose -arrow- off air filter housing and take hose out.
- Pull air filter housing upwards out of brackets and remove.

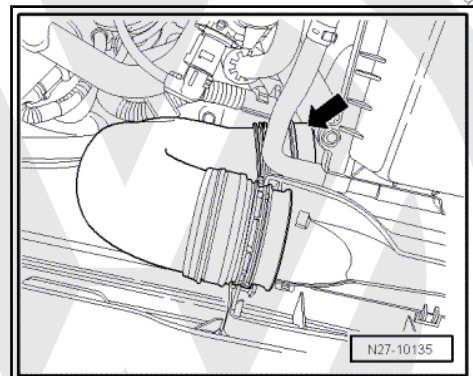

- Pull panel of battery box out upwards in direction of arrow.

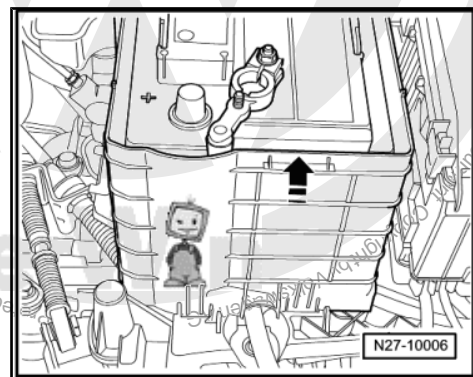



- Unscrew securing bolt -1- and remove battery holder -2-.

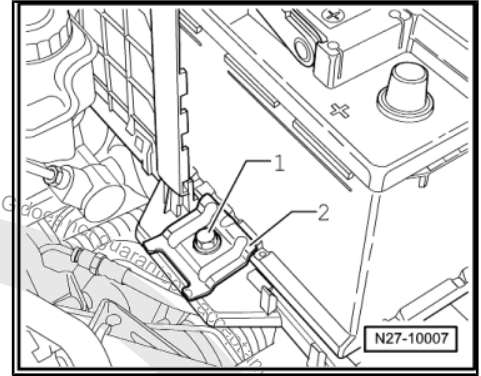

- Fold handles -arrows- upwards and take battery out.

Installing:

 **Caution**

A loosely fitted battery creates the following dangers:

- ◆ *Shortened service life due to damage from vibration (danger of explosion)*
- ◆ *The cells in the battery will be damaged if the battery is not secured correctly.*
- ◆ *Damage to battery housing by clamping bracket (possibility of acid leaking; therefore subsequent higher costs).*
- ◆ *Poor crash safety*

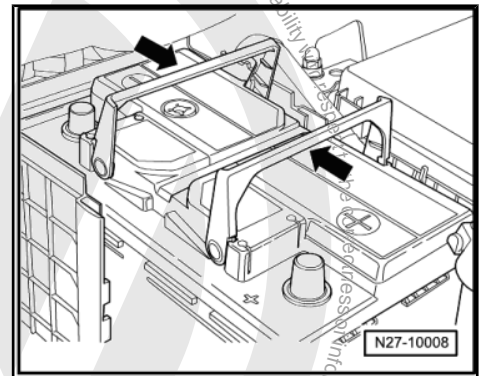

Installation is performed in the reverse order of installation; when doing this, note the following:

- Tighten threaded connections to specified torque settings ⇒ [page 36](#) .
- After installing, check that battery is seated securely.
- Connect the battery ⇒ [page 29](#) .

 **Caution**

Disconnecting and connecting the battery as described in the Workshop Manual ⇒ [page 29](#) .



6 Torque settings: battery

Threaded connections		Torque settings
Battery clamp to battery terminal	M6	6 Nm
Additional clamp to battery terminal clamp	M6	6 Nm
Securing bolt of battery holder	M8x35	20 Nm
Air filter housing to body		10 Nm



7 Starter



Caution

Disconnecting and connecting the battery as described in the Workshop Manual ⇒ [page 29](#).

7.1 Checking starter -B-

- Connect the vehicle diagnosis, testing and information system -VAS 5051A- to ⇒ [page 281](#)

Select “guided fault finding” in Vehicle Diagnosis, Testing and Information System -VAS 5051A- .

- Using the “Go to” key, select “Function/component selection” and the following menu items one after the other:
 - ◆ Body
 - ◆ Electrical System
 - ◆ 27 - Starter, current supply
 - ◆ Electrical components
 - ◆ B - Starter







7.2 Removing and installing starter, auto- matic gearbox

7.2.1 Vehicles with 1.6 l injection engine

Special tools and workshop equipment required

- ◆ Torque wrench -V.A.G 1331-
- ◆ Torque wrench -V.A.G 1332-
- ◆ Spring-type clip pliers -VAS 5024-

V.A.G 1331 	V.A.G 1332 
VAS 5024 	
	W10-0055

Removing:

- Disconnect the battery ⇒ [page 29](#) .
- Release spring-type clip -1- using spring type clip pliers -VAS 5024- and remove securing bolt -2-.
- Release hose -3- and pull it off the air filter housing.

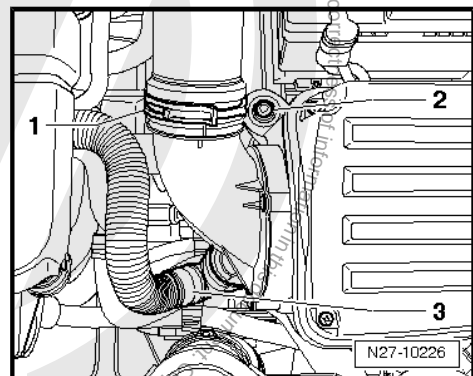



- Pull air filter housing on right side upwards off rubber mounting -arrow-.
- Remove air filter housing from vehicle.

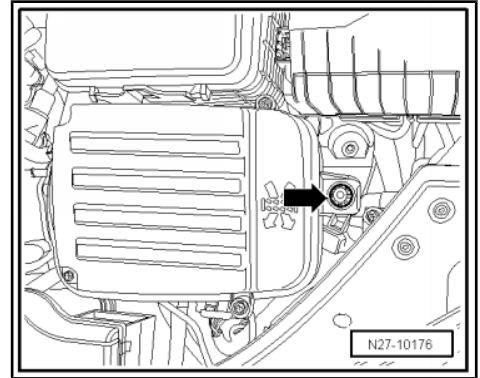

- Push down protective cap in -direction of arrow- from solenoid switch.

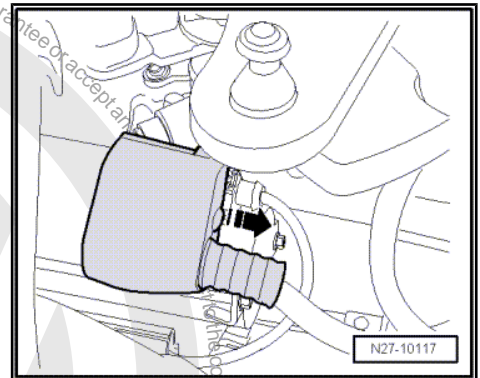

- Unscrew positive wire -1- and disconnect connector from terminal 50 -2-.
- Remove noise insulation => General Body Repairs, Exterior; Rep. Gr. 50 ; Body front; Noise insulation .

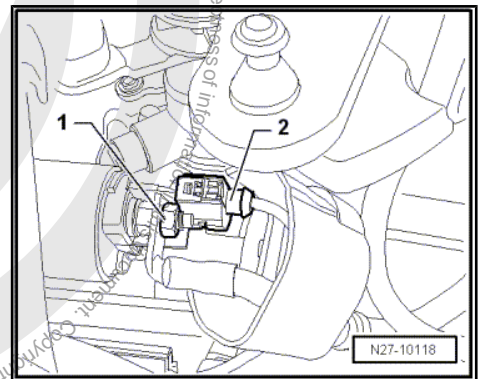

- Unscrew securing nut -1- from lower starter securing bolt.
- Remove wiring retainer -2-.

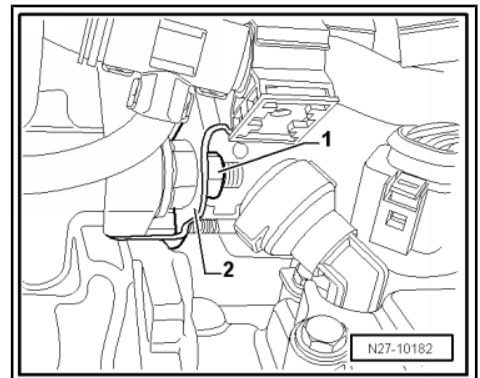



- Remove lower securing bolt of starter -arrow-.

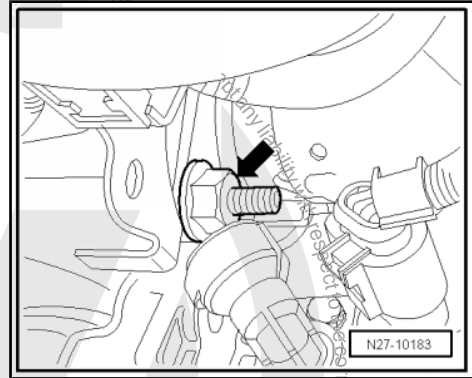

- Unscrew securing nut -1- from upper starter securing bolt.
- Remove wiring retainer -2-.

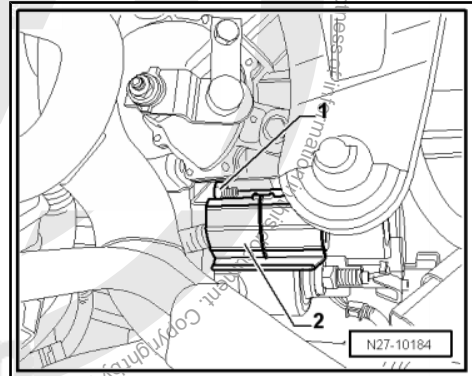

- Remove upper securing bolt of starter -arrow-.

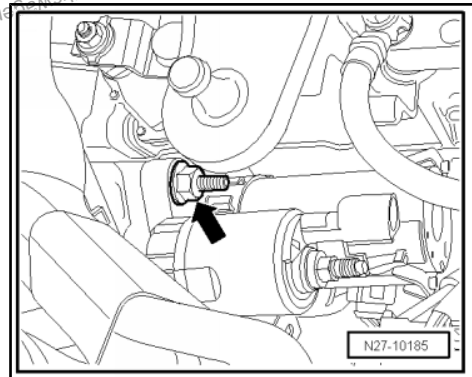

- Unscrew earth wire securing nut -1- and place earth wire -2- to one side.
- Remove starter from vehicle upwards.

Installing:

Installation is carried out in the reverse order. When installing, note the following:

- Tighten threaded connections to specified torque settings
=> [page 97](#) .

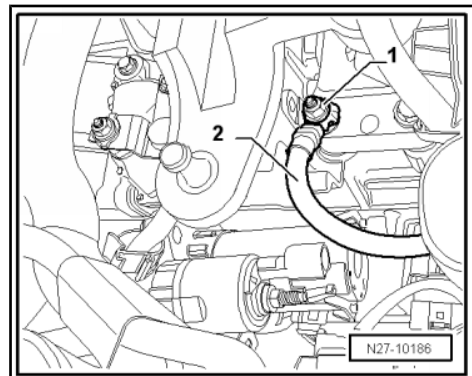

7.2.2 Vehicles with 1.6 I FSI engine

Special tools and workshop equipment required



- ◆ Torque wrench -V.A.G 1331-

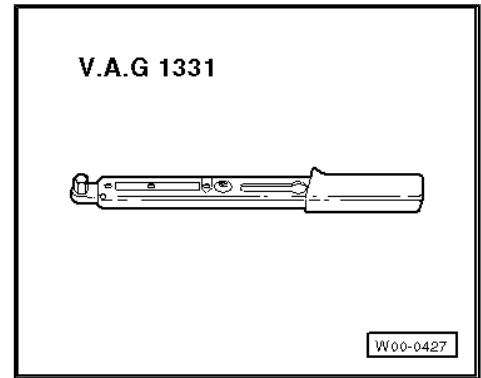

- ◆ Torque wrench -V.A.G 1332-

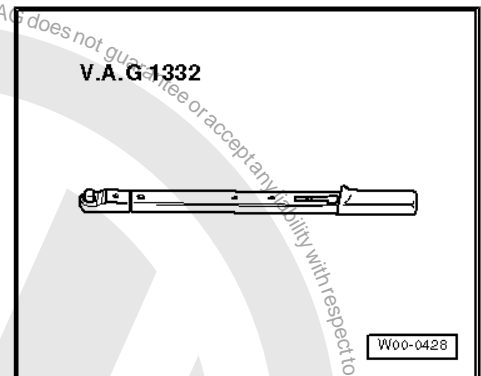

Removing:

- Disconnect the battery ⇒ [page 29](#) .
- Push down protective cap in -direction of arrow- from solenoid switch.

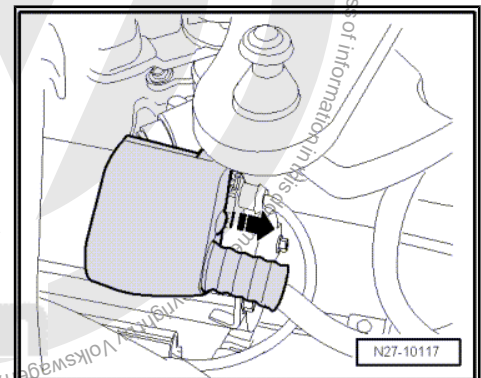

- Unscrew positive wire -1- and disconnect connector from terminal 50 -2-.
- Remove noise insulation ⇒ General Body Repairs, Exterior; Rep. Gr. 50 ; Body front; Noise insulation .

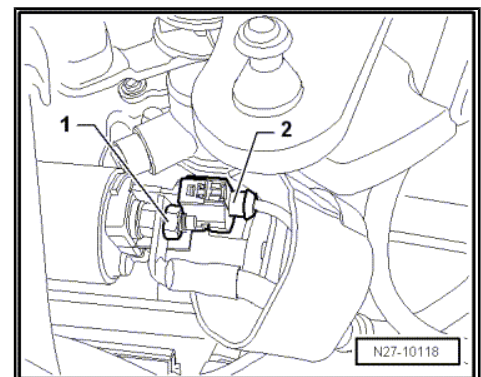



- Unscrew securing nut -1- from lower starter securing bolt.
- Remove wiring retainer -2-.

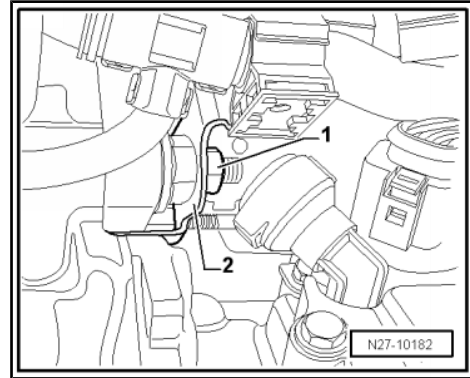

- Remove lower securing bolt of starter -arrow-.

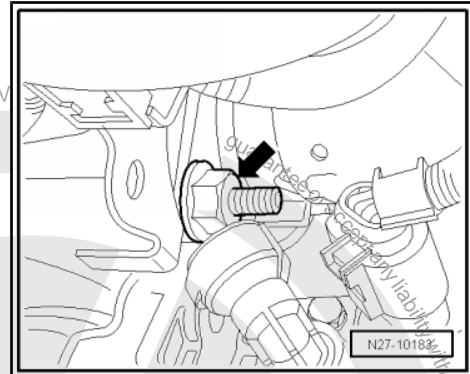

- Unscrew securing nut -1- from upper starter securing bolt.
- Remove wiring retainer -2-.

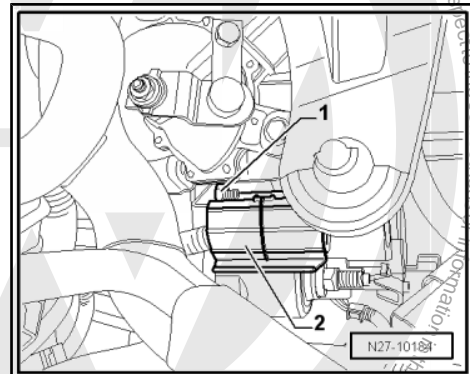

- Remove upper securing bolt of starter -arrow-.

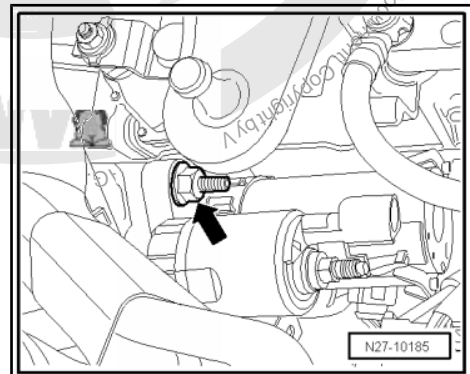



- Unscrew earth wire securing nut -1- and place earth wire -2- to one side.
- Remove starter from vehicle upwards.

Installing:

Installation is carried out in the reverse order. When installing, note the following:



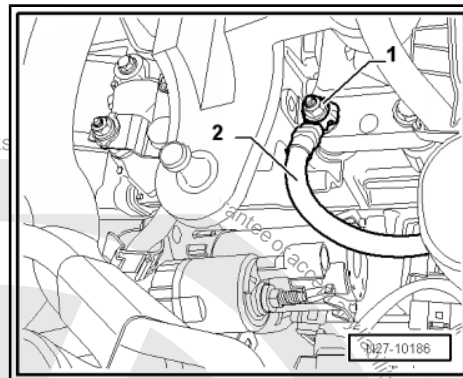

- Tighten threaded connections to specified torque settings
 => [page 97](#) .



7.2.3 Vehicles with 2,0 l FSI engine

Special tools and workshop equipment required

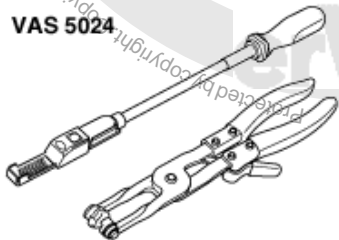
- ◆ Torque wrench -V.A.G 1331-
- ◆ Torque wrench -V.A.G 1332-
- ◆ Spring-type clip pliers -VAS 5024-

<p>V.A.G 1331</p> 	<p>V.A.G 1332</p> 
<p>VAS 5024</p> 	
<p style="text-align: right;">W10-0055</p>	

Removing:

- Disconnect the battery => [page 29](#) .



- Disconnect connector -arrow-.

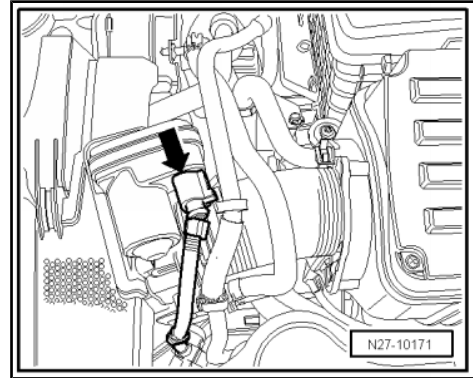

- Unclip vacuum hose from its mounting -arrow-.

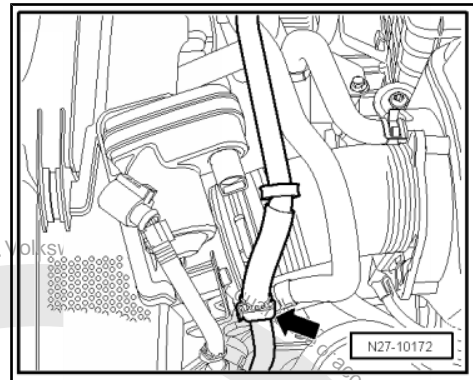

- Loosen spring-type clip -arrow- from hose -1- using spring type clip pliers -VAS 5024- .
- Pull hose -1- off air filter housing.

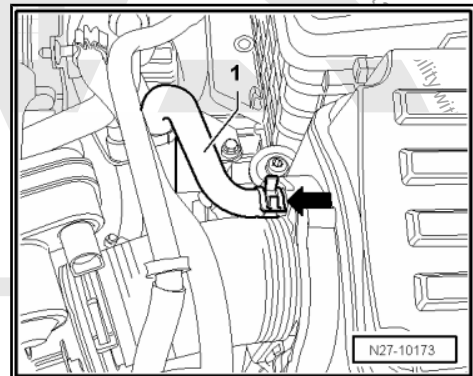

- Open retainer -arrow- on front side of air filter housing and take hose -1- off.

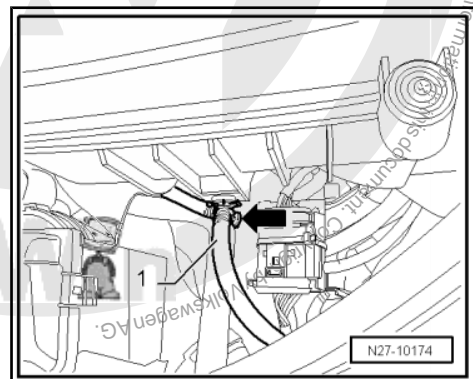



- Unscrew air filter housing securing bolt -arrow-.

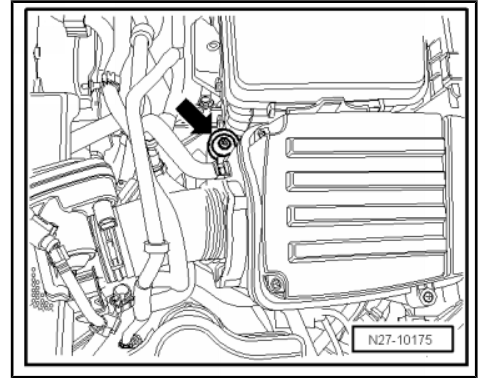

- Pull air filter housing on right side upwards off rubber mounting -arrow-.

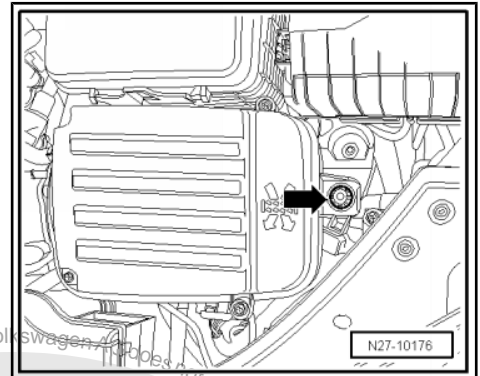

- Loosen spring-type clip -1- using spring type clip pliers -VAS 5024- .
- Pull hose -2- off pipe union.
- Carefully lift air filter housing upwards out of the vehicle taking into consideration the length of the hose.

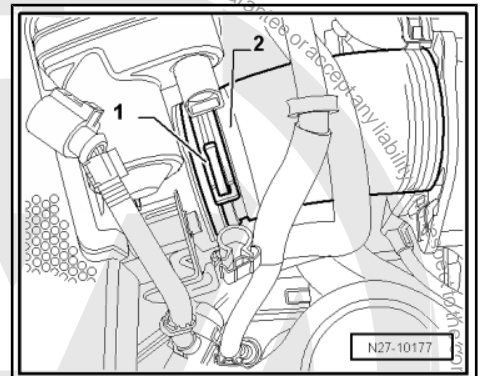

- Separate connector -arrow- on rear of air filter housing.

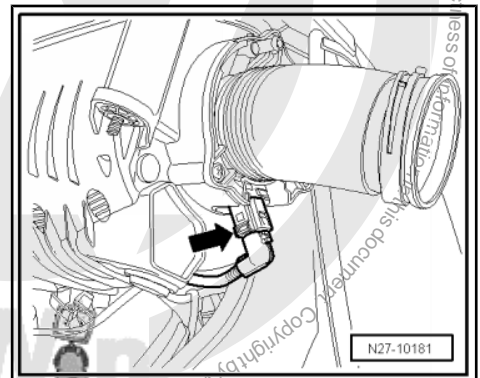



- Remove air filter housing from vehicle.
- Push down protective cap in -direction of arrow- from solenoid switch.

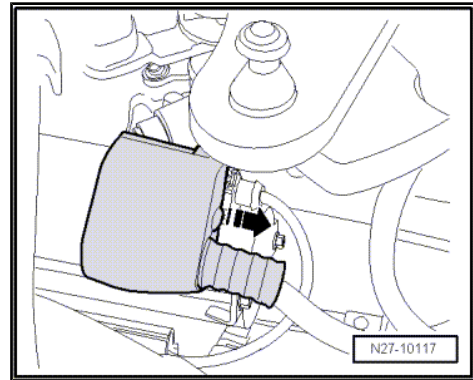

- Unscrew positive wire -1- and disconnect connector from terminal 50 -2-.
- Remove noise insulation => General Body Repairs, Exterior; Rep. Gr. 50 ; Body front; Noise insulation .

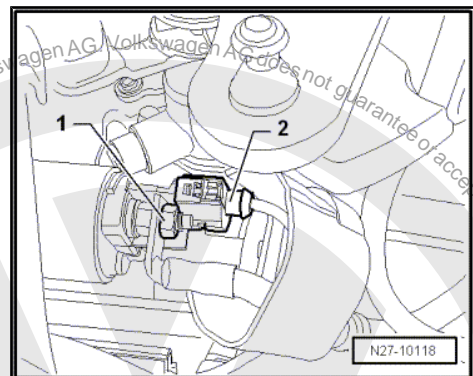

- Unscrew securing nut -1- from lower starter securing bolt.
- Remove wiring retainer -2-.

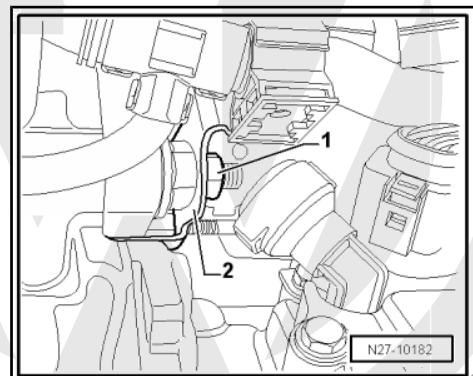

- Remove lower securing bolt of starter -arrow-.

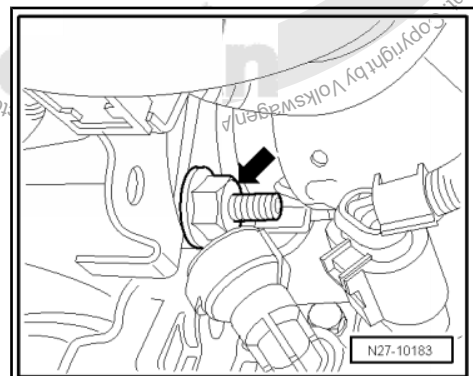



- Unscrew securing nut -1- from upper starter securing bolt.
- Remove wiring retainer -2-.

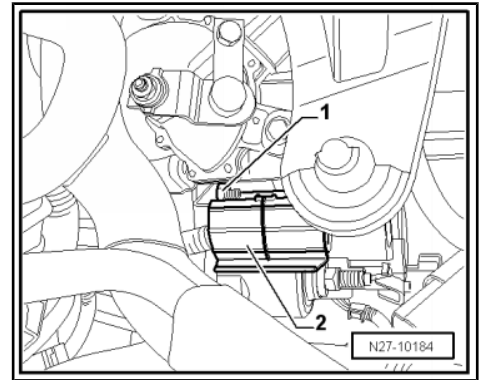

- Remove upper securing bolt of starter -arrow-.

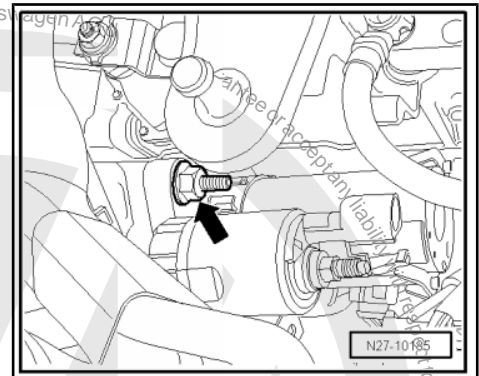

- Unscrew earth wire securing nut -1- and place earth wire -2- to one side.
- Remove starter from vehicle upwards.

Installing:

Installation is carried out in the reverse order. When installing, note the following:

- Tighten threaded connections to specified torque settings
=> [page 97](#) .

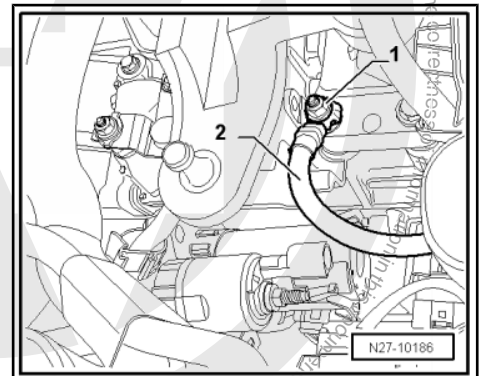



7.2.4 Vehicles with 2,5 l injection engine

Special tools and workshop equipment required

- ◆ Torque wrench -V.A.G 1331-
- ◆ Torque wrench -V.A.G 1332-
- ◆ Spring-type clip pliers -VAS 5024-

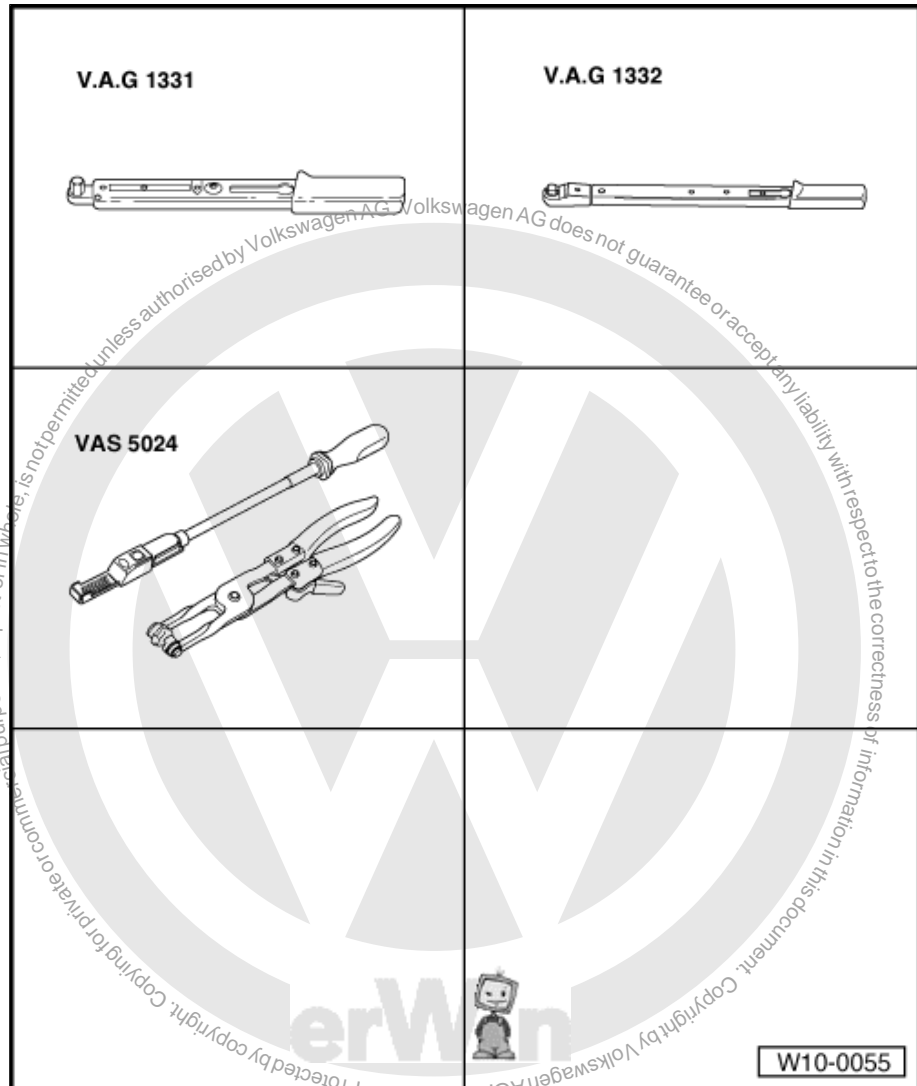

Removing:

- Disconnect the battery ⇒ [page 29](#) .
- Pull engine cover off upwards -arrows-.

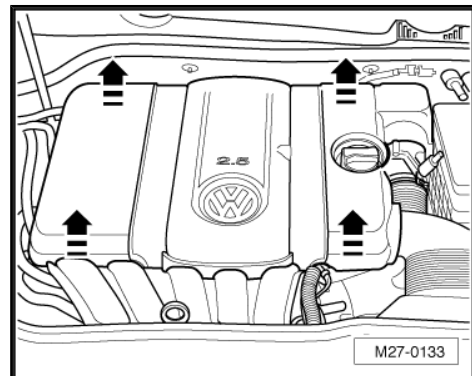



- Separate connector -1-, release spring-type clip -2- with spring type clip pliers -VAS 5024- and pull off vacuum hose -3-.
- Pull air filter housing upwards out of brackets and remove.

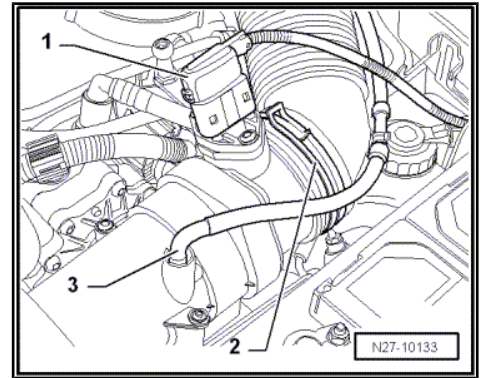

- Push down protective cap -direction of arrow- from solenoid switch.

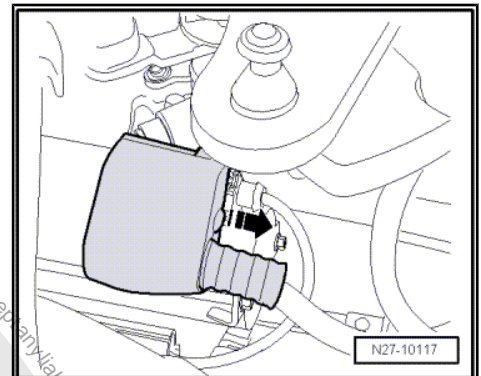

- Unscrew positive wire -1- and disconnect connector from terminal 50 -2-.
- Remove noise insulation => General Body Repairs, Exterior; Rep. Gr. 50 ; Body front; Noise insulation .

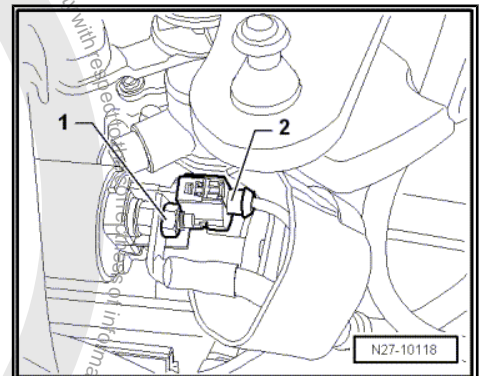

- Unscrew nut -1- from lower starter securing bolt.
- Remove wiring retainer -2-.

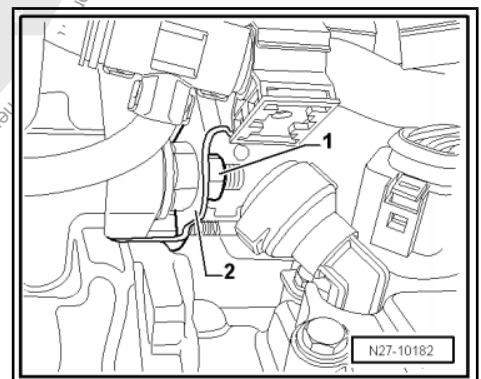



- Remove lower securing bolt of starter -arrow-.

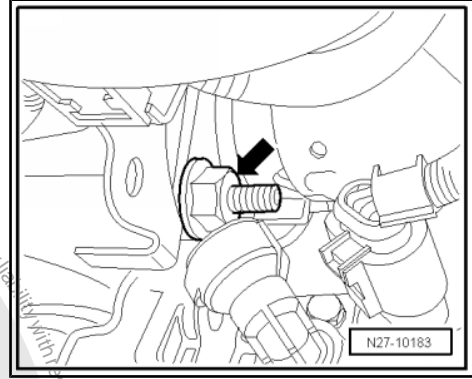

Unscrew nut -1- from upper starter securing bolt.
Remove wiring retainer -2-.

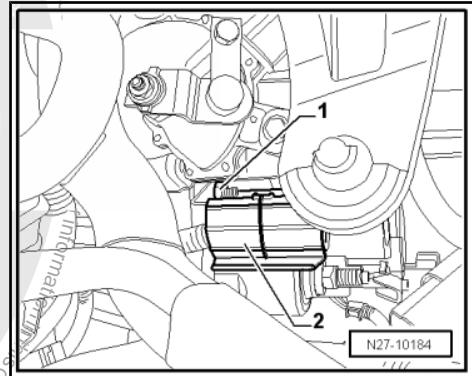

- Remove upper securing bolt of starter -arrow-.
- Remove starter from vehicle downwards.

Installing:

Installation is carried out in the reverse order. When installing, note the following:

- Tighten threaded connections to specified torque settings
⇒ [page 97](#) .

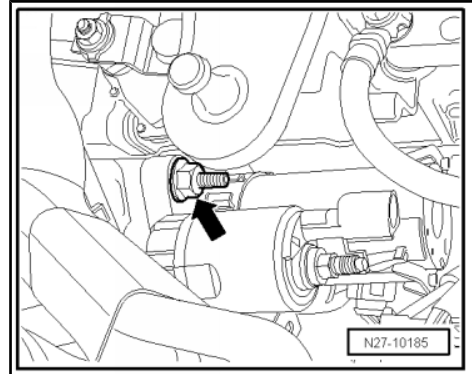



7.2.5 Vehicles with 1.9 l TDI engine

Special tools and workshop equipment required

- ◆ Torque wrench -V.A.G 1331-
- ◆ Torque wrench -V.A.G 1332-
- ◆ Spring-type clip pliers -VAS 5024-

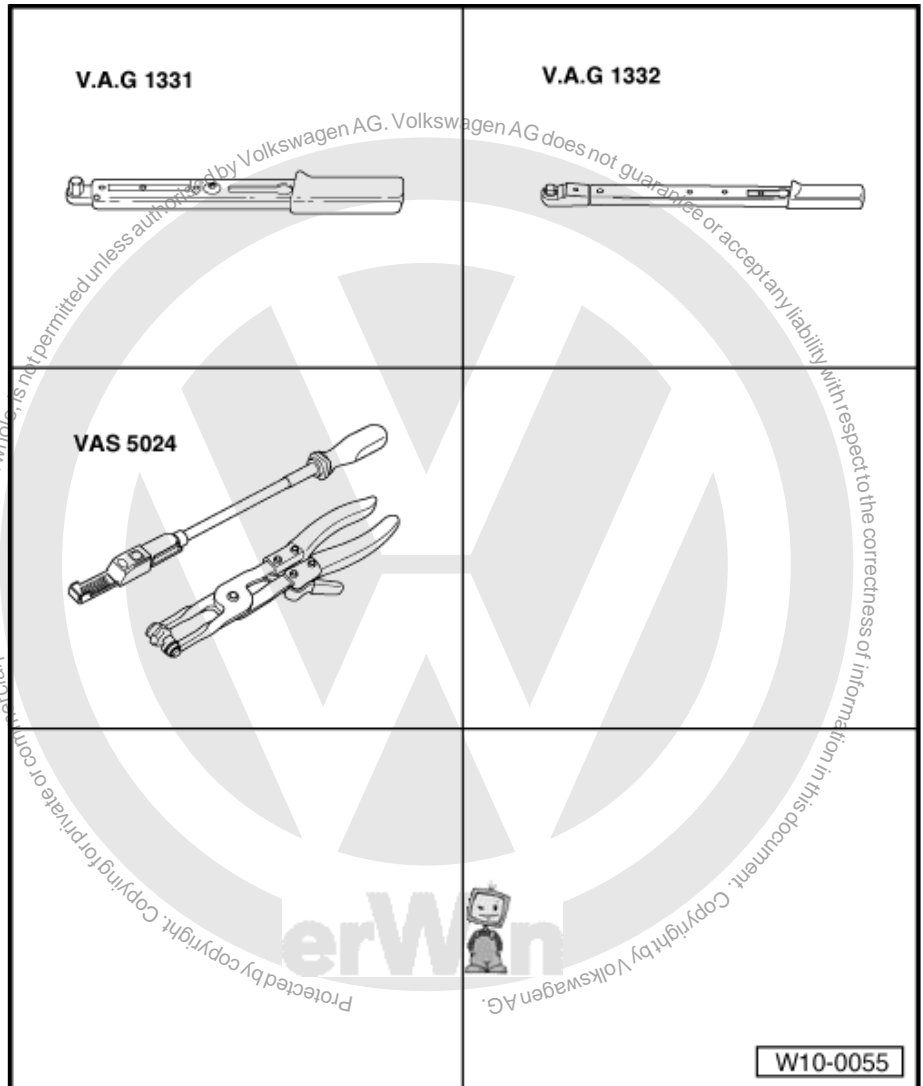

Removing:

- Disconnect the battery ⇒ [page 29](#) .
- Pull engine cover upwards -arrows A- and forwards -arrow B-.

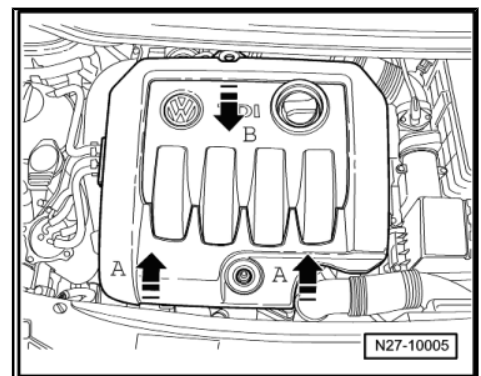



- Disconnect connector -1- and loosen spring type clip -2- with spring type clip pliers -VAS 5024- .

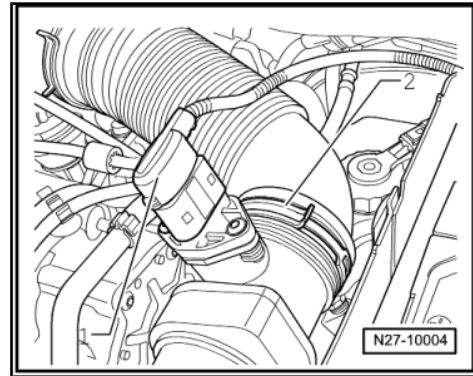

- Pull the vacuum hose -arrow- off air filter housing.

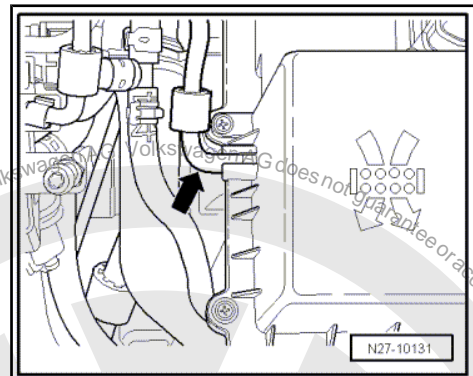

- Unscrew air filter housing securing bolt -arrow-.

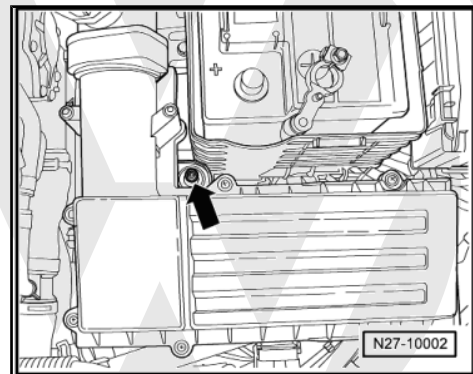

- Unlock lugs -arrows- and take cover off.

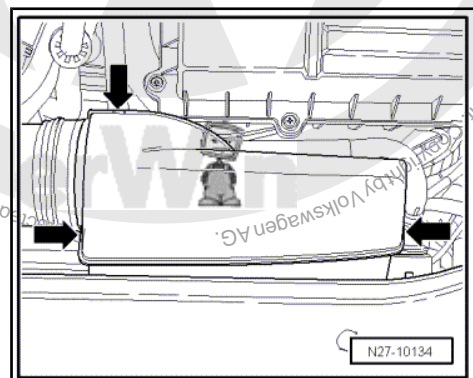



- Pull hose -arrow- off air filter housing and take hose out.
- Pull air filter housing upwards out of brackets and remove.

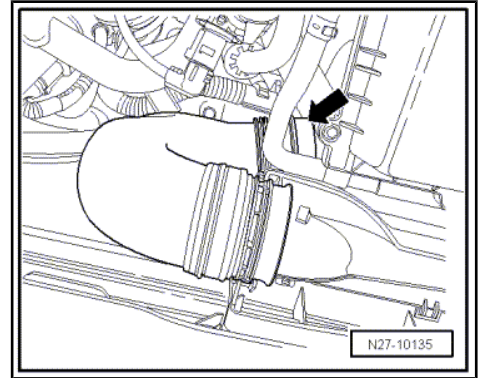

- Push down protective cap -direction of arrow- from solenoid switch.

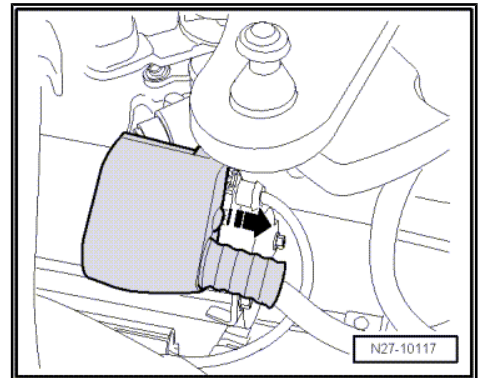

- Unscrew positive wire -1- and disconnect connector from terminal 50 -2-.
- Remove noise insulation => General Body Repairs, Exterior; Rep. Gr. 50 ; Body front; Noise insulation .

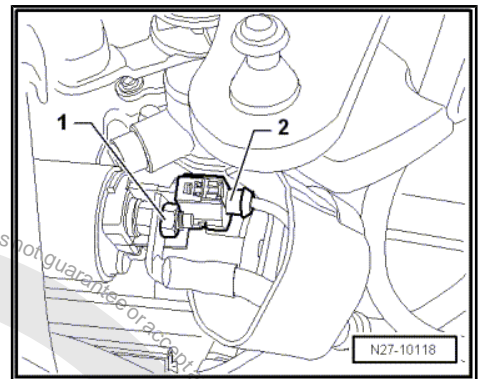

- Unscrew nut -1- from lower starter securing bolt.
- Remove wiring retainer -2-.

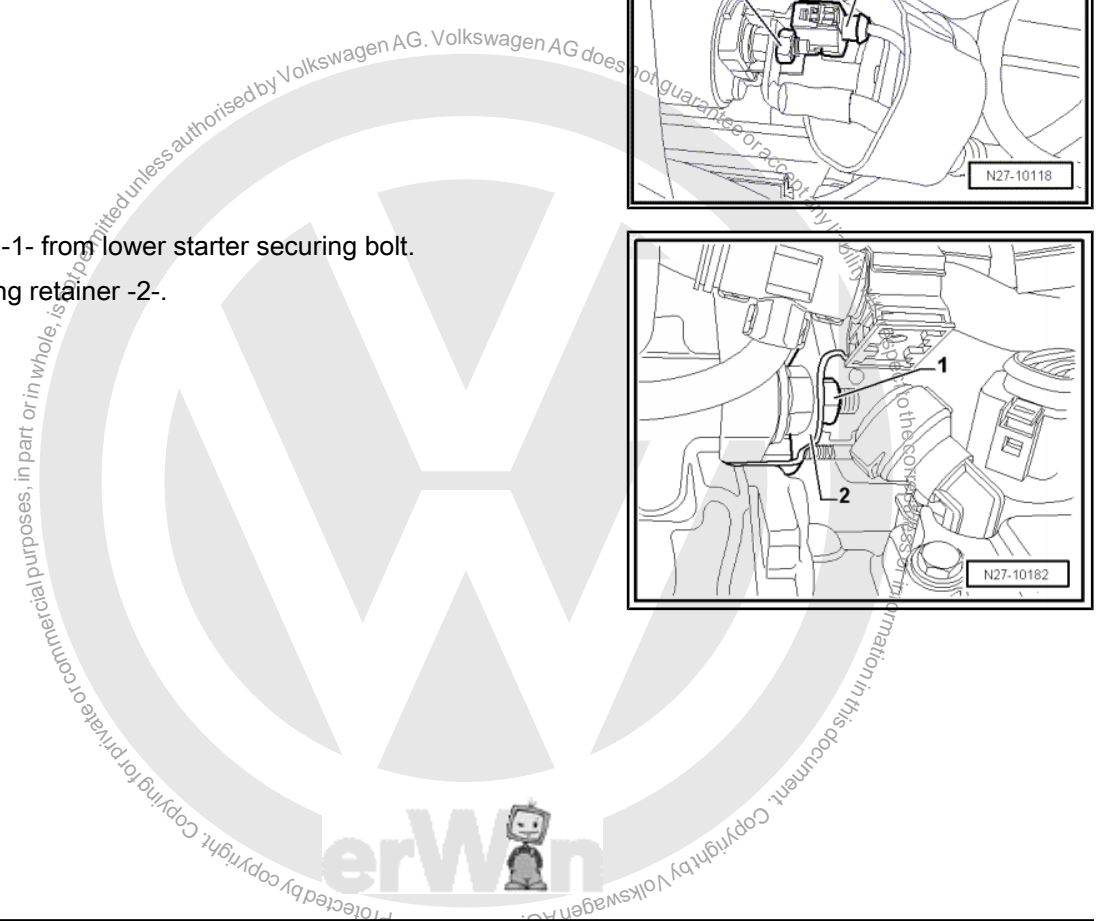
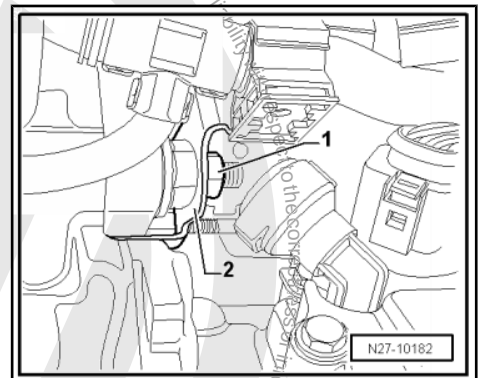



- Remove lower securing bolt of starter -arrow-.

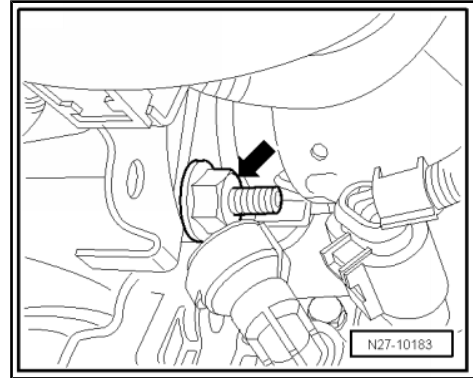

- Unscrew nut -1- from upper starter securing bolt.
- Remove wiring retainer -2-.

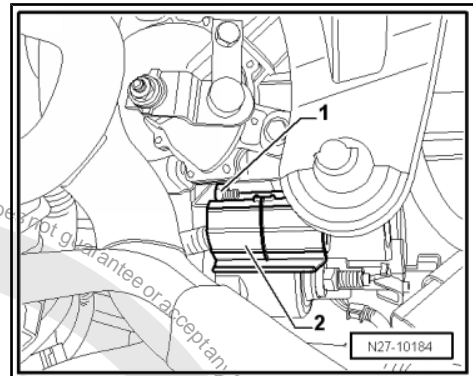

- Remove upper securing bolt of starter -arrow-.

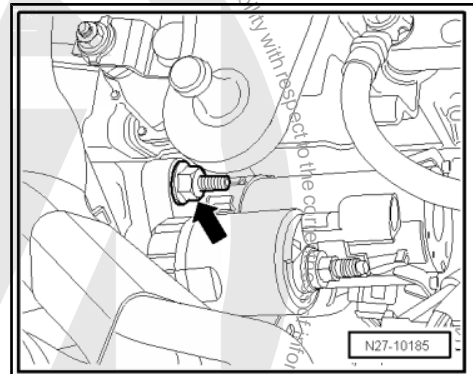

- Unscrew earth wire securing nut -1- and place earth wire end -2- in direction of battery to side.
- Remove starter from vehicle upwards.

Installing:

Installation is carried out in the reverse order. When installing, note the following:

- Tighten threaded connections to specified torque settings
⇒ [page 97](#) .

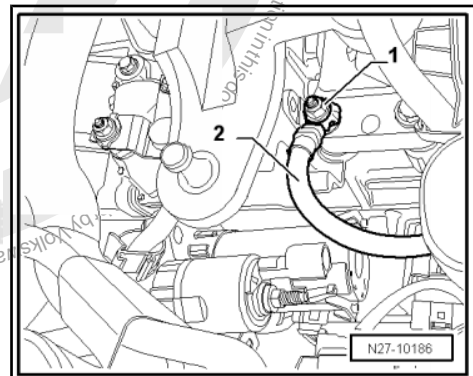



7.2.6 Vehicles with 2.0 l SDI engine

Special tools and workshop equipment required

- ◆ Torque wrench -V.A.G 1331-
- ◆ Torque wrench -V.A.G 1332-
- ◆ Spring-type clip pliers -VAS 5024-

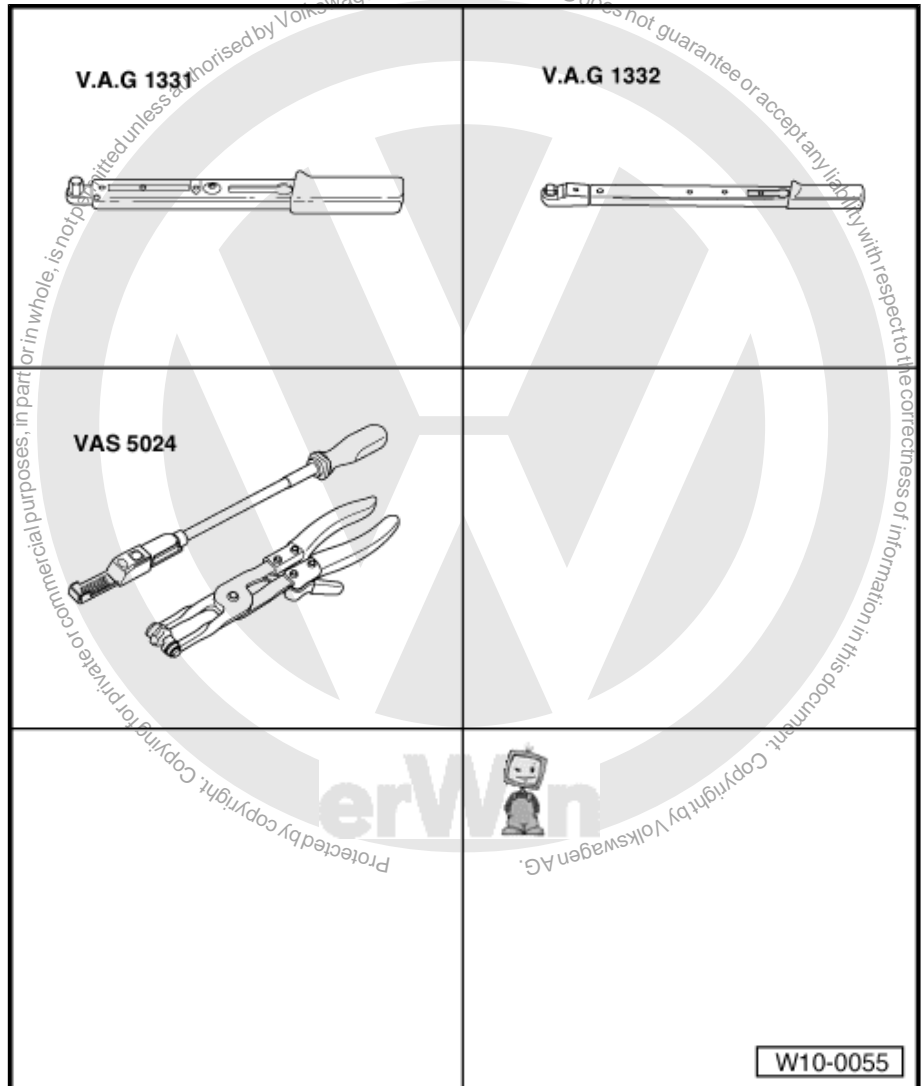

Removing:

- Disconnect the battery ⇒ [page 29](#) .
- Pull engine cover upwards -arrows A- and forwards -arrow B-.

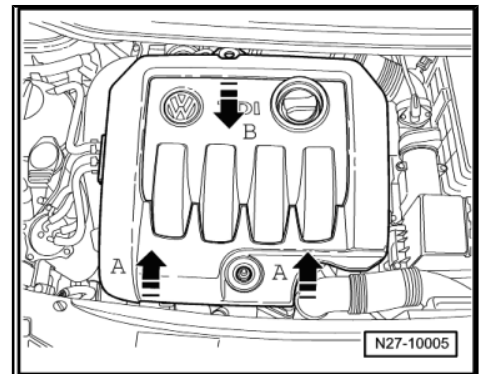



- Release spring-type clip -1- using spring type clip pliers -VAS 5024- and disconnect connector -2-.
- Remove securing bolt -3-.

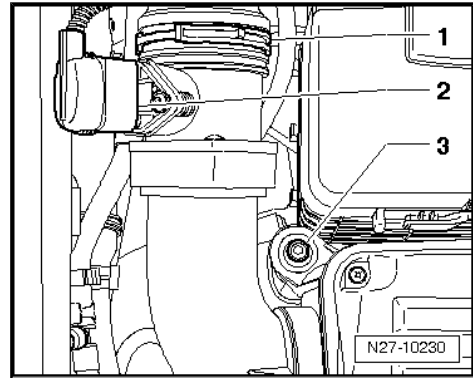

- Pull vacuum hose off -arrow-.

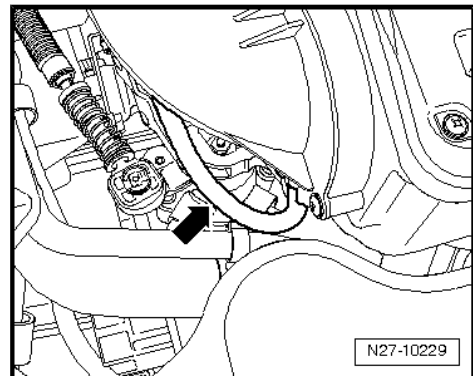

- Pull air filter housing on right side upwards off rubber mounting -arrow-.
- Remove air filter housing from vehicle.

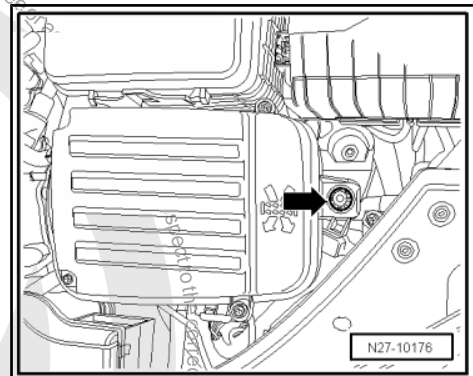

- Push down protective cap in -direction of arrow- from solenoid switch.

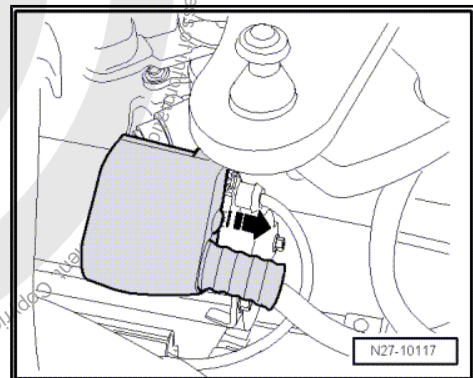



- Unscrew positive wire -1- and disconnect connector from terminal 50 -2-.

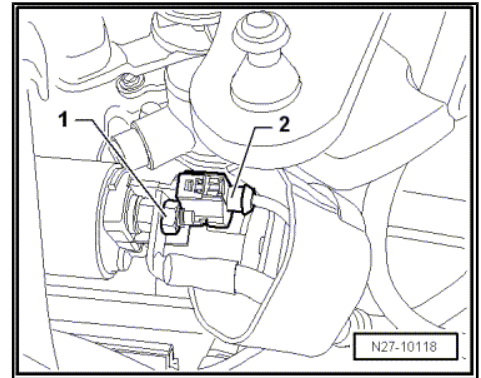

- Unscrew earth wire from starter securing bolt -arrow-.

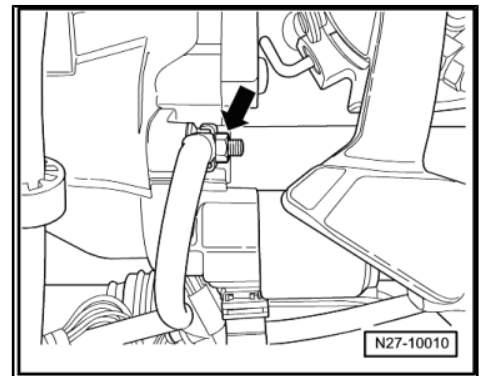

- Unscrew starter securing bolt -arrow-.
- Remove noise insulation => General Body Repairs, Exterior; Rep. Gr. 50 ; Body front; Noise insulation .

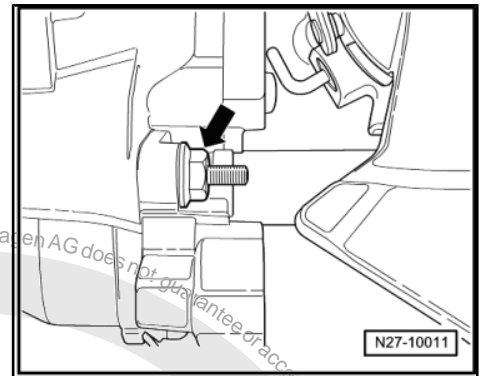

- Unscrew securing nut -1- from lower starter securing bolt.
- Remove wiring retainer -2-.

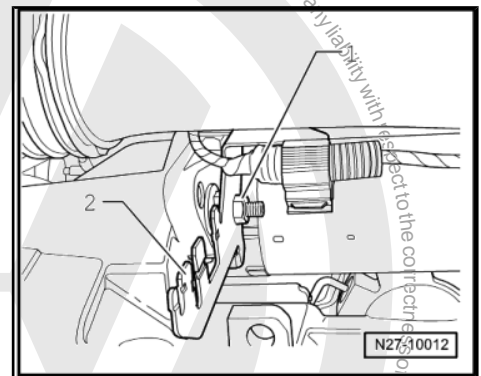



- Unscrew starter securing bolt -arrow-.
- Remove starter from vehicle downwards.

Installing:

Installation is carried out in the reverse order. When installing, note the following:

- Tighten threaded connections to specified torque settings
⇒ [page 97](#) .

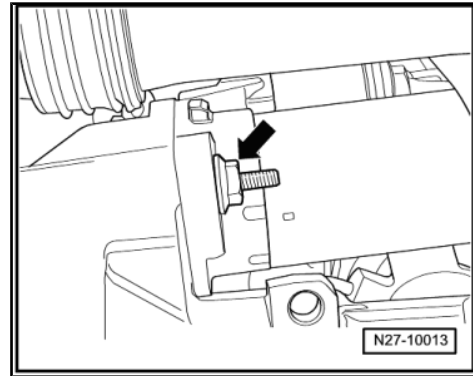

7.3 Removing and installing starter, automated shift gearboxes

7.3.1 Vehicles with 1.6 I injection engine

Special tools and workshop equipment required

- ◆ Torque wrench -V.A.G 1331-
- ◆ Torque wrench -V.A.G 1332-
- ◆ Spring-type clip pliers -VAS 5024-

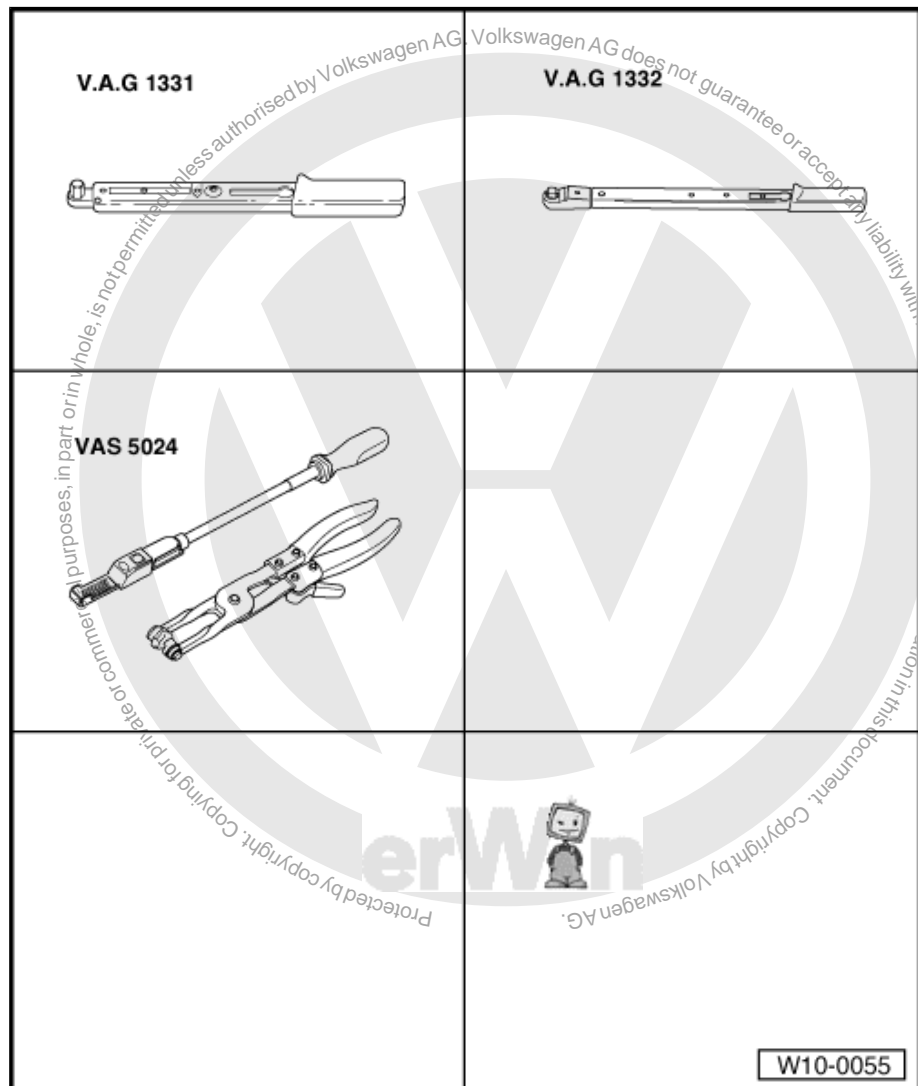

Removing:

- Disconnect the battery ⇒ [page 29](#) .



- Release spring-type clip -1- using spring type clip pliers -VAS 5024- and remove securing bolt -2-.
- Release hose -3- and pull it off the air filter housing.

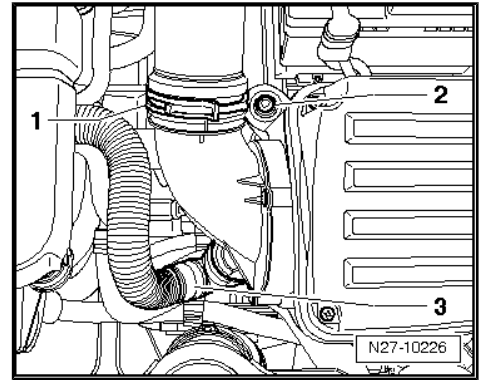

- Pull air filter housing on right side upwards off rubber mounting -arrow-.
- Remove air filter housing from vehicle.

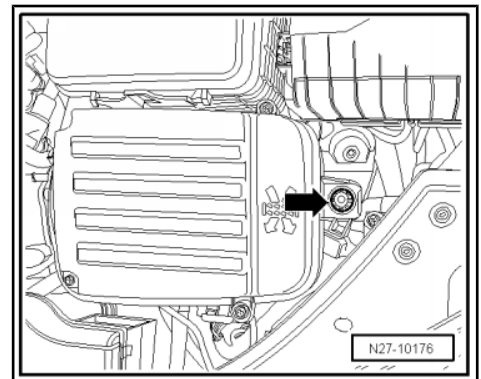

- Push down protective cap in -direction of arrow- from solenoid switch.

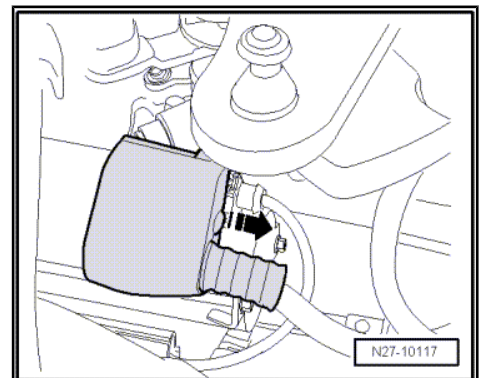

- Unscrew positive wire -1- and disconnect connector from terminal 50 -2-.

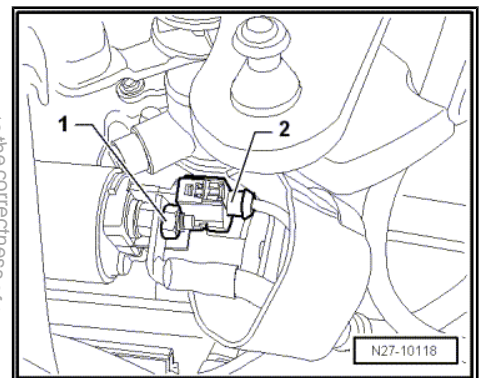



- Unscrew earth wire from starter securing bolt -arrow-.

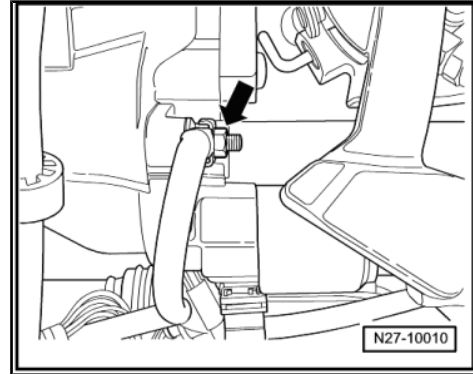

- Unscrew starter securing bolt -arrow-.
- Remove noise insulation => General Body Repairs, Exterior; Rep. Gr. 50 ; Body front; Noise insulation .

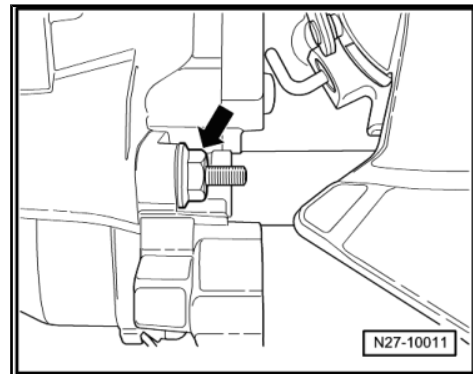

- Unscrew securing nut -1- from lower starter securing bolt.
- Remove wiring retainer -2-.

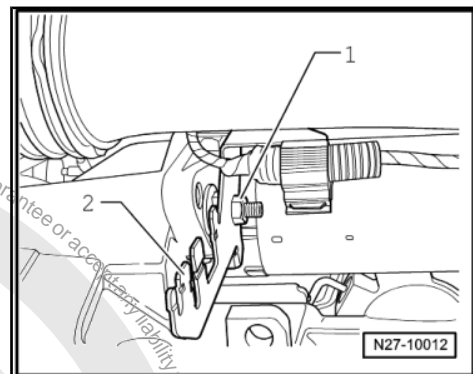

- Unscrew starter securing bolt -arrow-.
- Remove starter from vehicle downwards.

Installing:

Installation is carried out in the reverse order. When installing, note the following:

- Tighten threaded connections to specified torque settings => [page 97](#) .

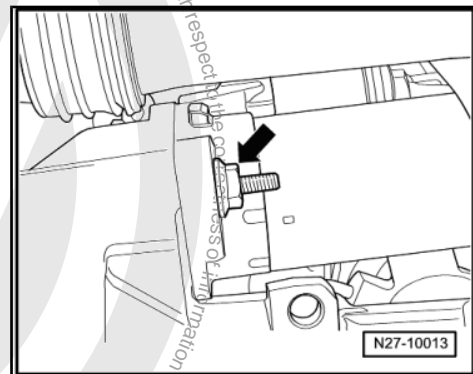



7.3.2 Vehicles with 2,0l FSI engine

Special tools and workshop equipment required

- ◆ Torque wrench -V.A.G 1331-
- ◆ Torque wrench -V.A.G 1332-
- ◆ Spring-type clip pliers -VAS 5024-

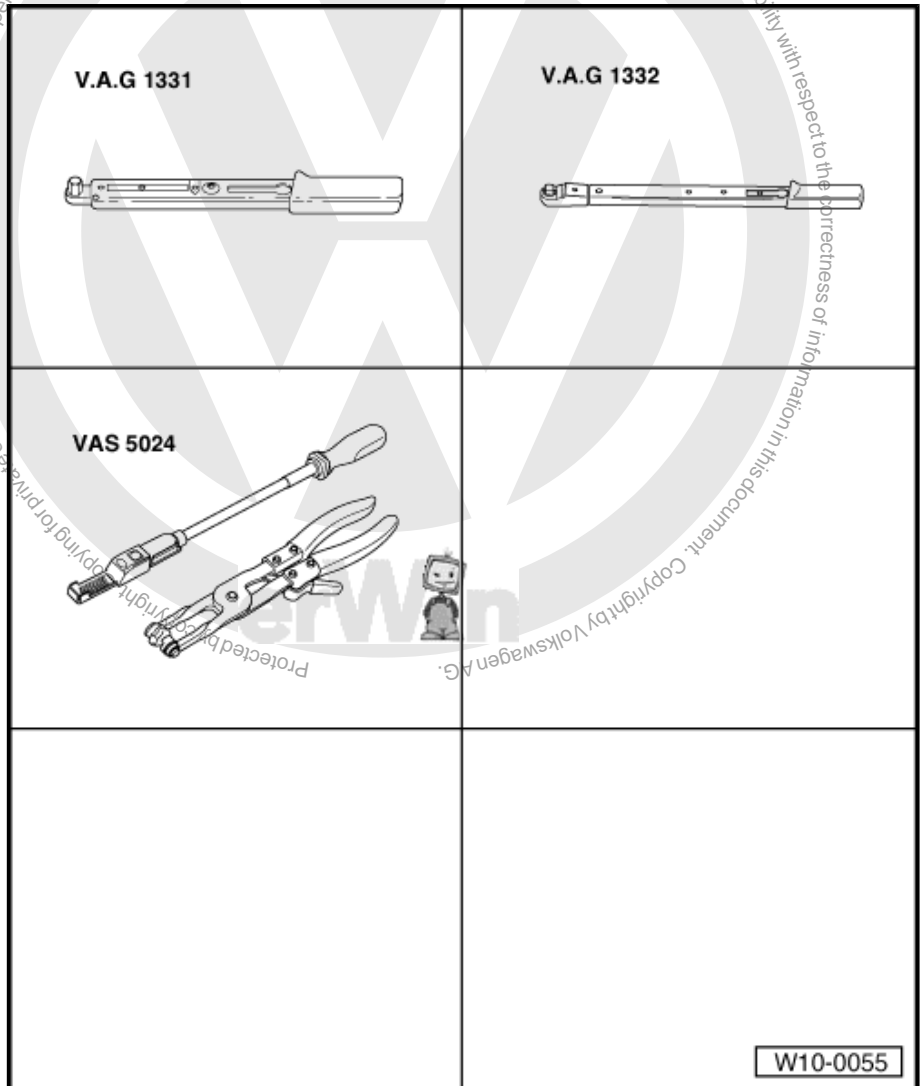

Removing:

- Disconnect the battery ⇒ [page 29](#) .
- Disconnect connector -arrow-.

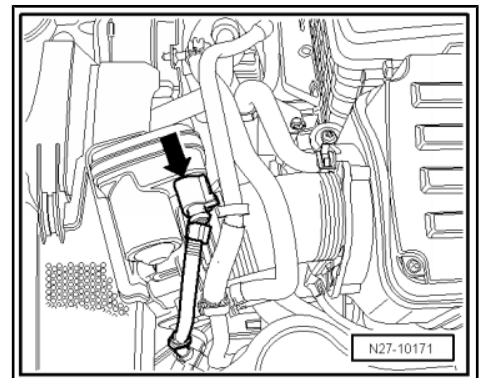



- Unclip vacuum hose from its mounting -arrow-.

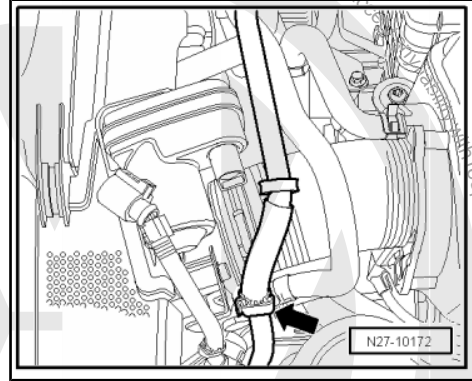

- Loosen spring-type clip -arrow- from hose -1- using spring type clip pliers -VAS 5024- .
- Pull hose -1- off air filter housing.

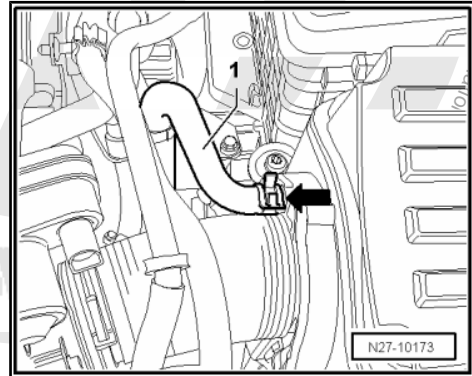

- Open retainer -arrow- on front side of air filter housing and take hose -1- off.

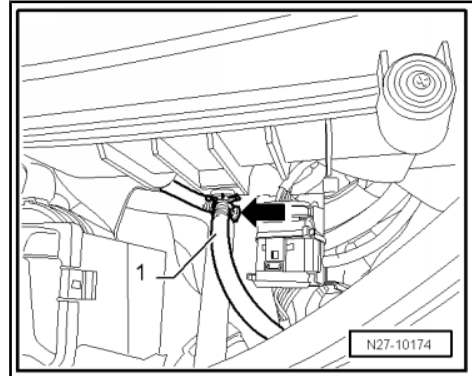

- Unscrew air filter housing securing bolt -arrow-.

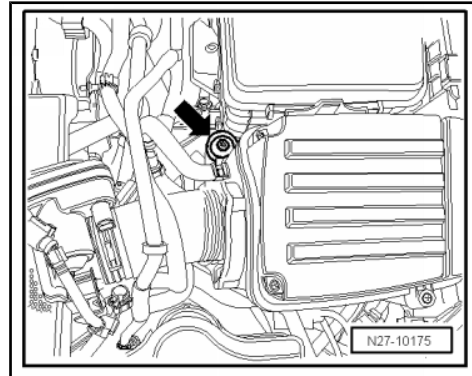



- Pull air filter housing on right side upwards off rubber mounting -arrow-.

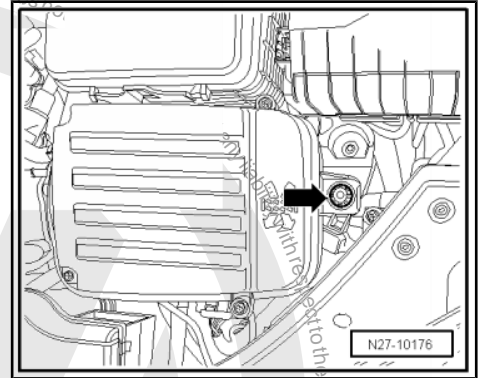

- Loosen spring-type clip -1- using spring type clip pliers -VAS 5024- .
- Pull hose -2- off pipe union.
- Carefully lift air filter housing upwards out of the vehicle taking into consideration the length of the hose.

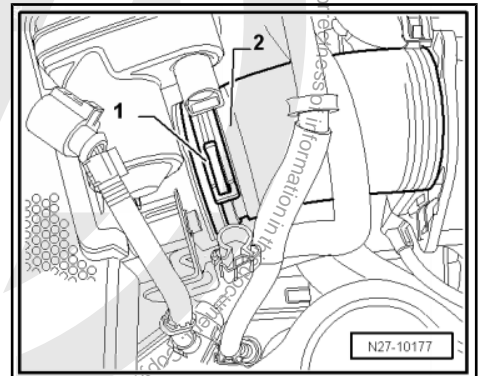

- Separate connector -arrow- on rear of air filter housing.

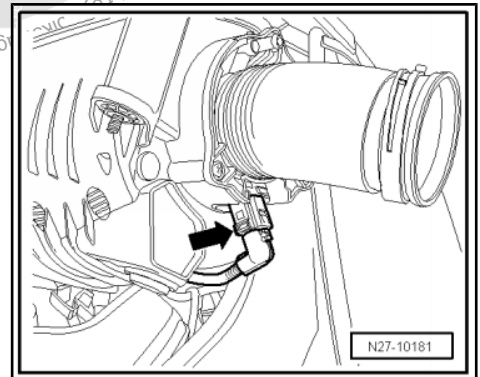

- Remove air filter housing from vehicle.
- Push down protective cap in -direction of arrow- from solenoid switch.

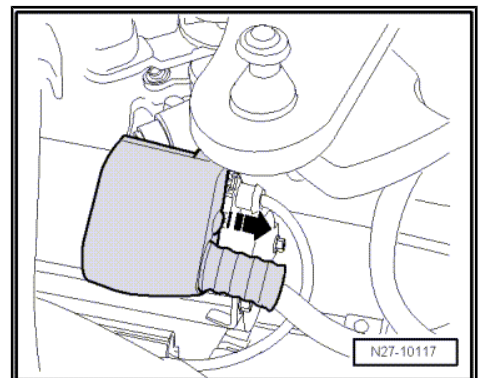



- Unscrew positive wire -1- and disconnect connector from terminal 50 -2-.

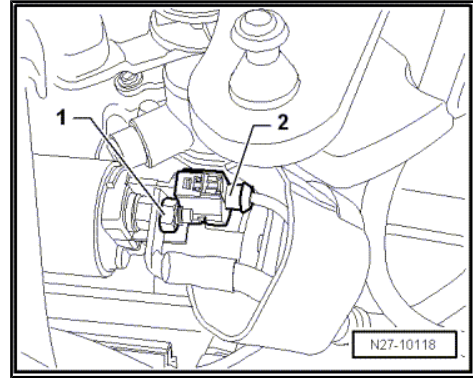

- Unscrew securing nut -1- from upper starter securing bolt.
- Remove wiring retainer -2-.

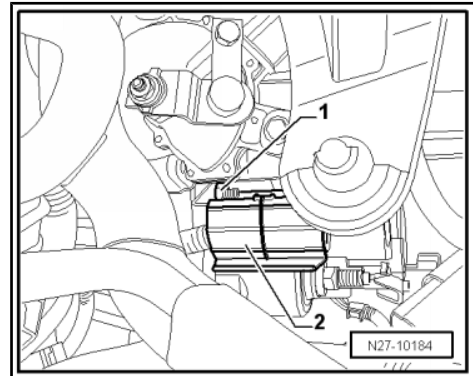

- Remove upper securing bolt of starter -arrow-.
- Remove noise insulation => General Body Repairs, Exterior; Rep. Gr. 50 ; Body front; Noise insulation .

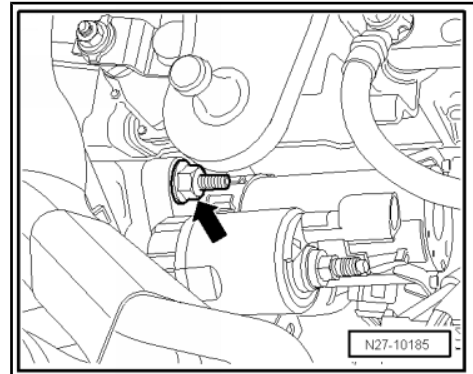

- Remove connectors -arrows-.





- Unscrew securing nut -1- from lower starter securing bolt.
- Remove wiring retainer -2-.

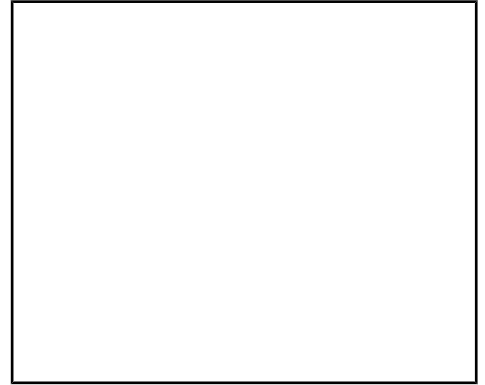

- Remove lower securing bolt of starter -arrow-.
- Remove starter from vehicle downwards.

Installing:

Installation is carried out in the reverse order. When installing, note the following:

- Tighten threaded connections to specified torque settings
⇒ [page 97](#) .

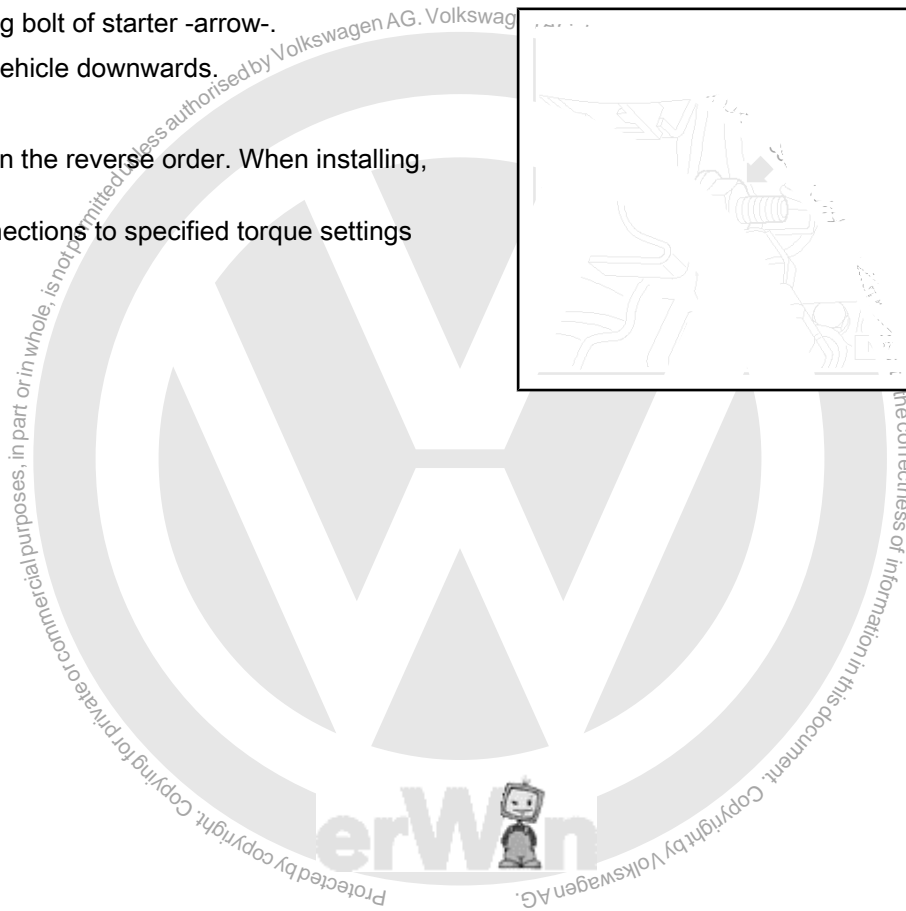



7.3.3 Vehicles with 2.0 I FSI turbo engine

Special tools and workshop equipment required

- ◆ Torque wrench -V.A.G 1331-
- ◆ Torque wrench -V.A.G 1332-
- ◆ Spring-type clip pliers -VAS 5024-

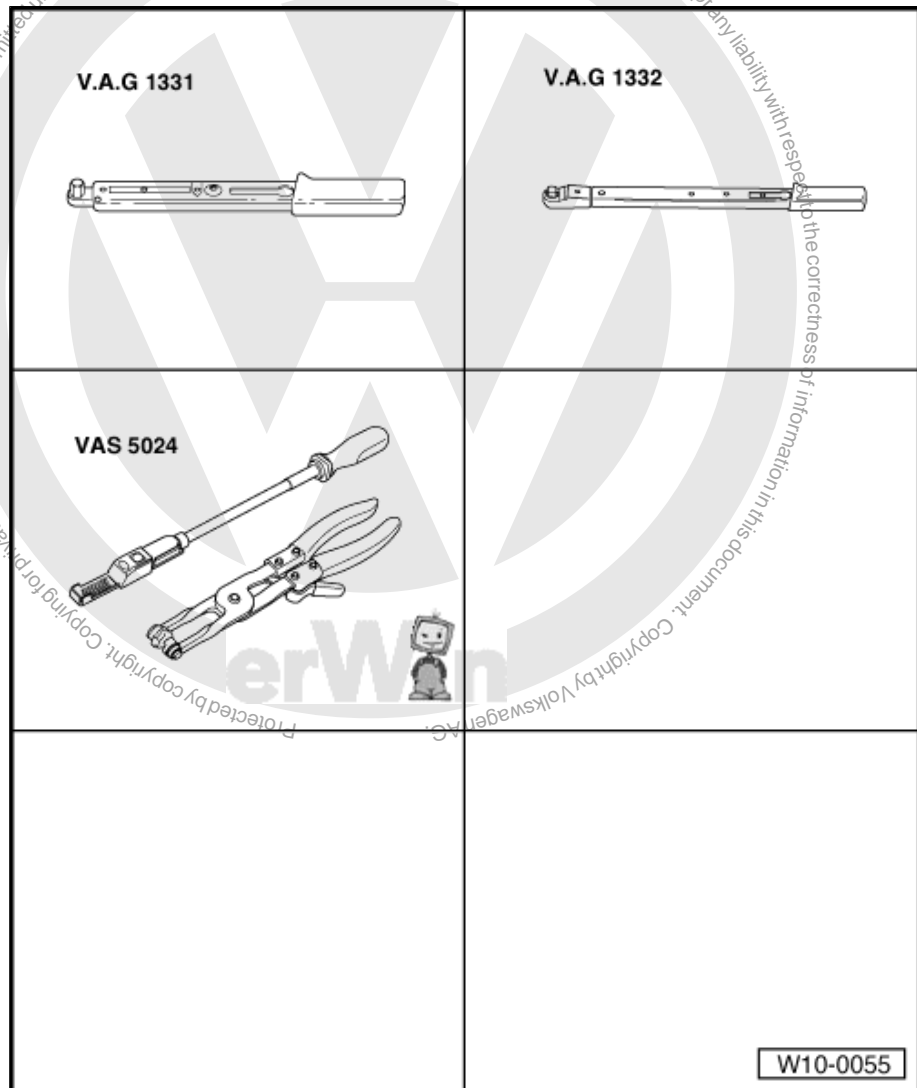

Removing:

- Disconnect the battery ⇒ [page 29](#) .
- Unbolt securing bolts -arrow-.

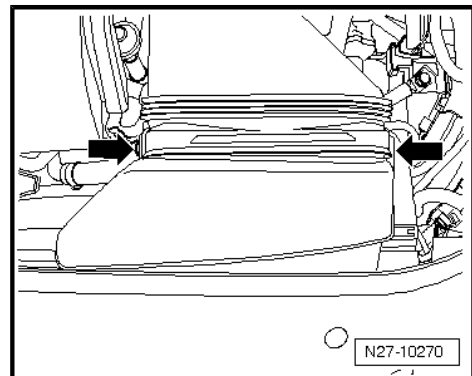



- Disconnect connector -arrow-.

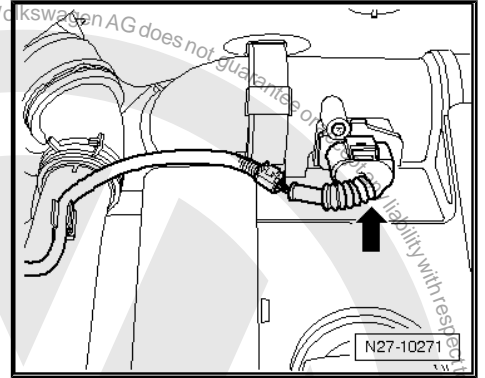

- Loosen spring-type clips -1- using spring type clip pliers -VAS 5024- .

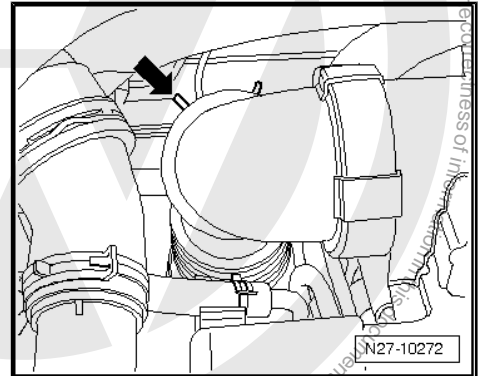

- Pull engine cover off upwards -arrows-.

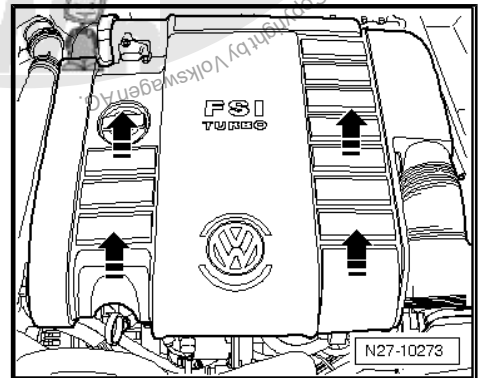

- Push down protective cap in -direction of arrow- from solenoid switch.

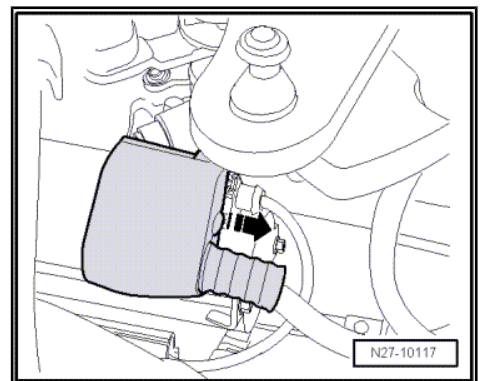



- Unscrew positive wire -1- and disconnect connector from terminal 50 -2-.

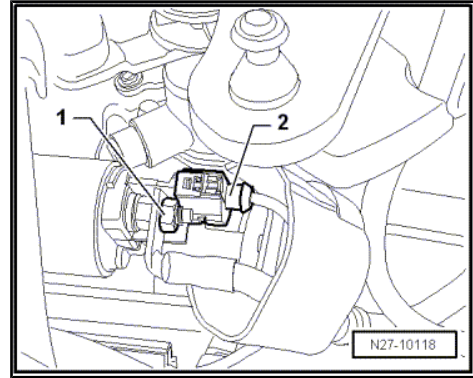

- Remove upper securing bolt of starter -arrow-.

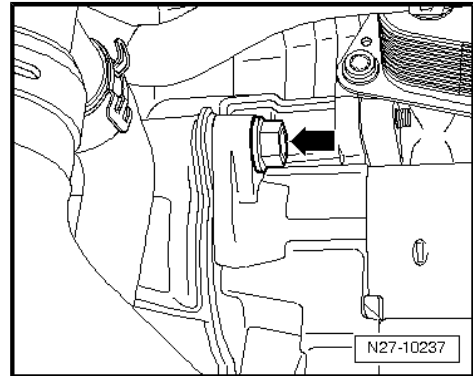

- Remove lower securing bolt of starter -arrow-.
- Remove starter from vehicle upwards.

Installing:

Installation is carried out in the reverse order. When installing, note the following:

- Tighten threaded connections to specified torque settings
=> [page 97](#) .

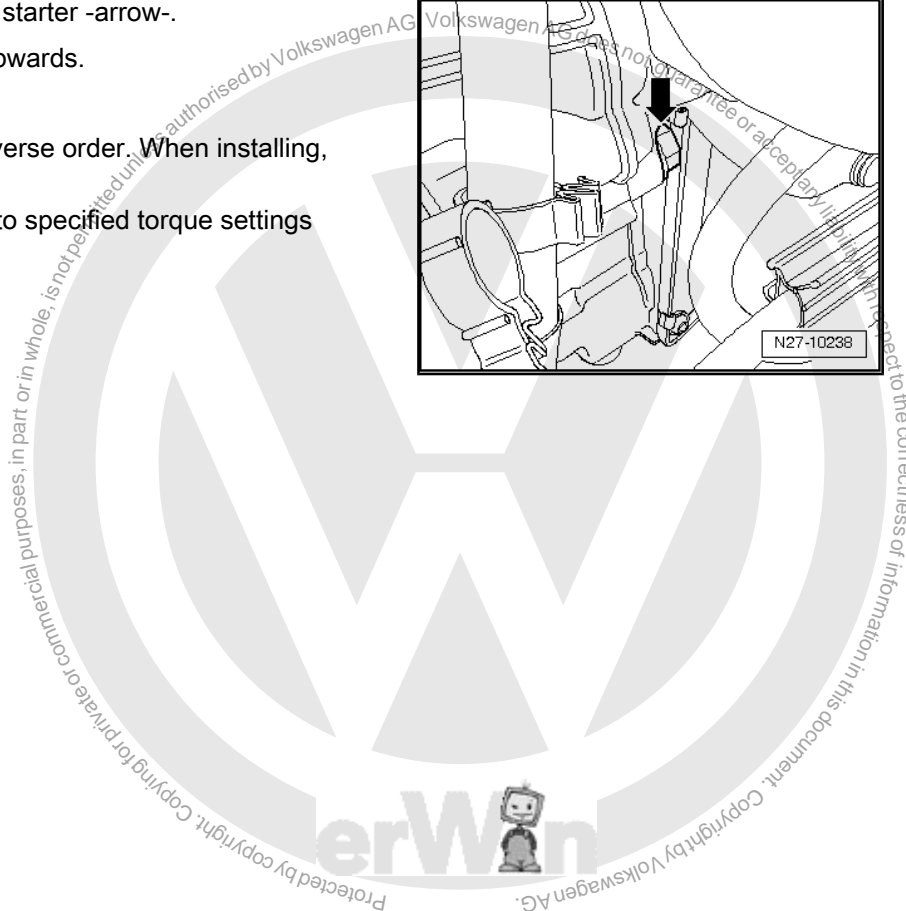
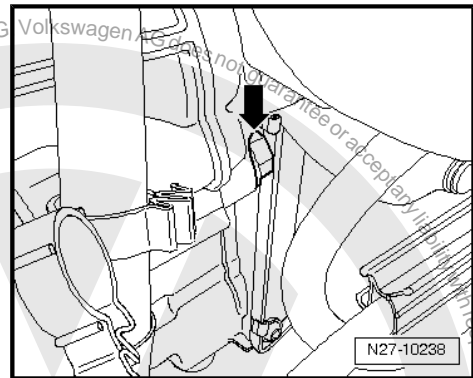





7.3.4 Vehicles with 1.9 l TDI engine

Special tools and workshop equipment required

- ◆ Torque wrench -V.A.G 1331-
- ◆ Torque wrench -V.A.G 1332-
- ◆ Spring-type clip pliers -VAS 5024-

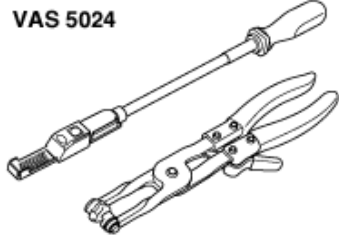
<p>V.A.G 1331</p> 	<p>V.A.G 1332</p> 
<p>VAS 5024</p> 	
<p>W10-0055</p>	

Removing:

- Disconnect the battery ⇒ [page 29](#) .
- Pull engine cover upwards -arrows A- and forwards -arrow B-.

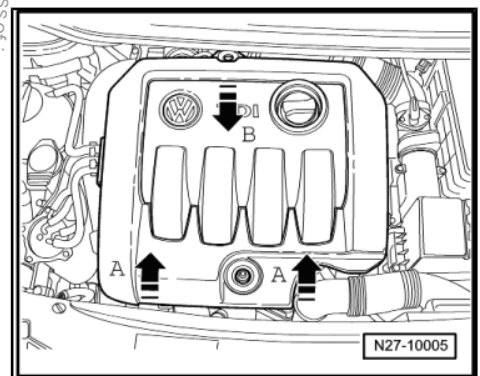

Protected by copyright. Copying for private or commercial purposes, in part or in whole, is not permitted unless authorised by Volkswagen AG. Volkswagen AG does not guarantee or accept any liability with respect to the correctness of information in this document. Copyright by Volkswagen AG.



- Disconnect connector -1- and loosen spring type clip -2- with spring type clip pliers -VAS 5024- .

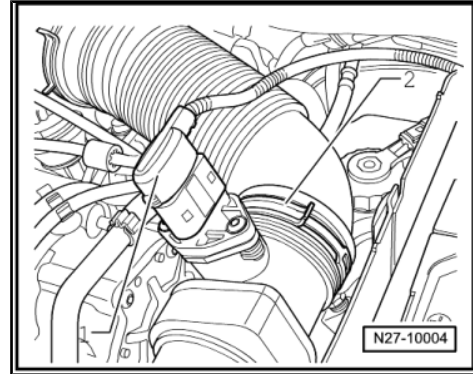

- Pull the vacuum hose -arrow- off air filter housing.

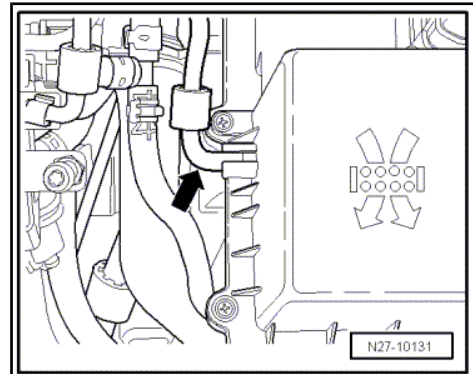

- Unscrew air filter housing securing bolt -arrow-.

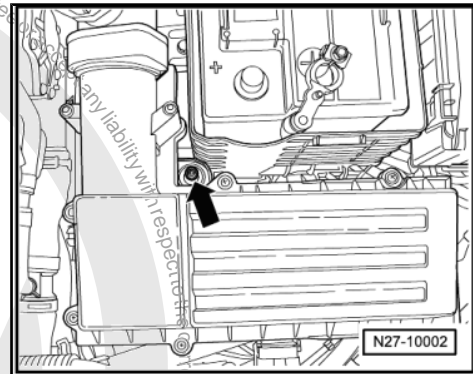

- Unlock lugs -arrows- and take cover off.

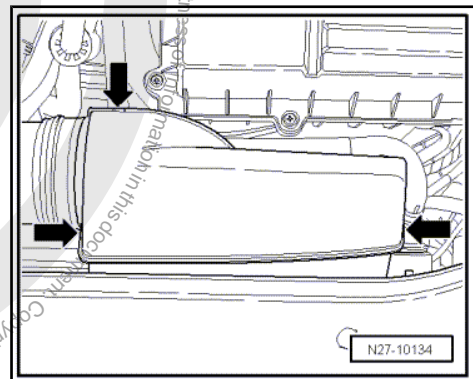



- Pull hose -arrow- off air filter housing and take hose out.
- Pull air filter housing upwards out of brackets and remove.

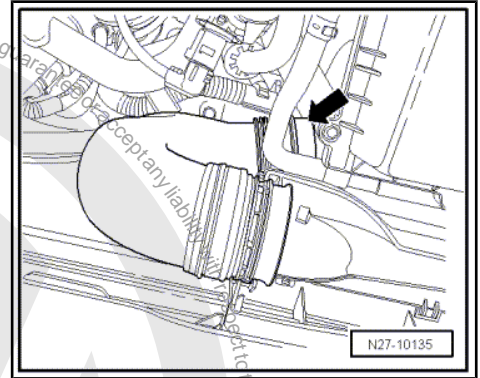

- Push down protective cap -direction of arrow- from solenoid switch.

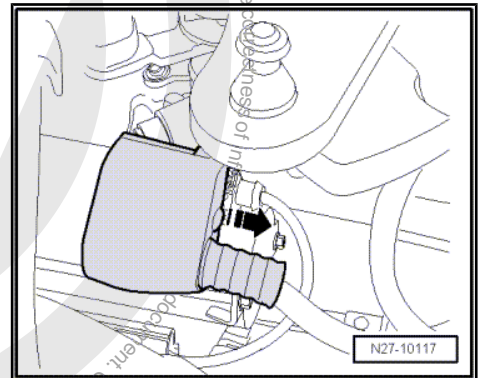

- Unscrew positive wire -1- and disconnect connector from terminal 50 -2-.

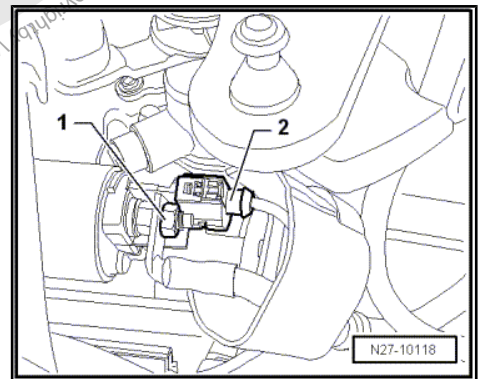

- Remove upper securing bolt of starter -arrow-.

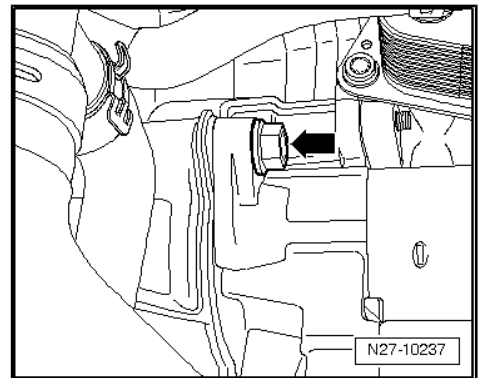



- Remove lower securing bolt of starter -arrow-.
- Remove starter from vehicle upwards.

Installing:

Installation is carried out in the reverse order. When installing, note the following:

- Tighten threaded connections to specified torque settings
⇒ [page 97](#) .

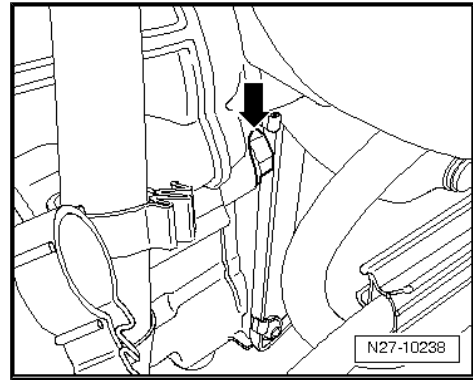

7.3.5 Vehicles with 2,0 I TDI engine

Special tools and workshop equipment required

- ◆ Torque wrench -V.A.G 1331-
- ◆ Torque wrench -V.A.G 1332-
- ◆ Spring-type clip pliers -VAS 5024-

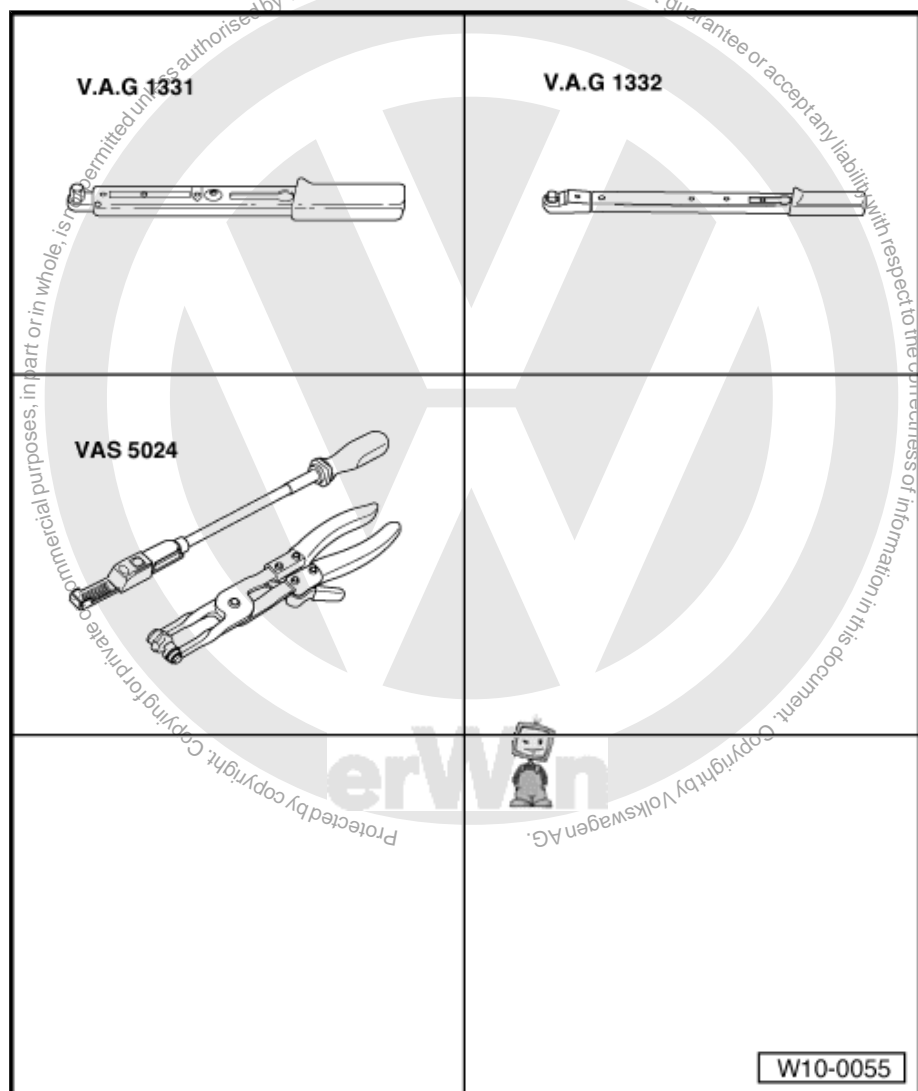

Removing:

- Disconnect the battery ⇒ [page 29](#) .



- Pull engine cover off upwards -arrows-.

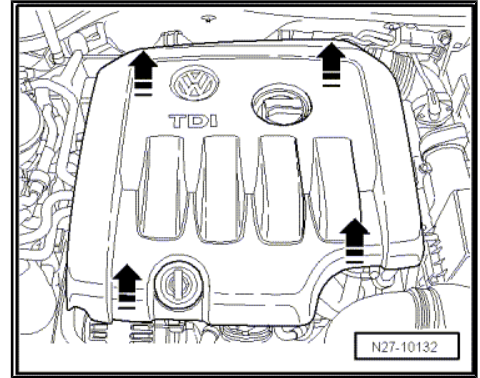

- Separate connector -1-, release spring-type clip -2- with spring type clip pliers -VAS 5024- and pull off vacuum hose -3-.

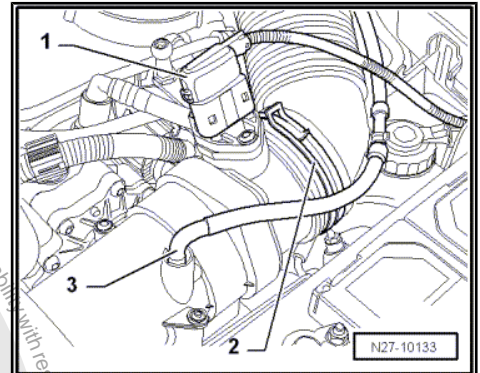

Unscrew air filter housing securing bolt -arrow-.

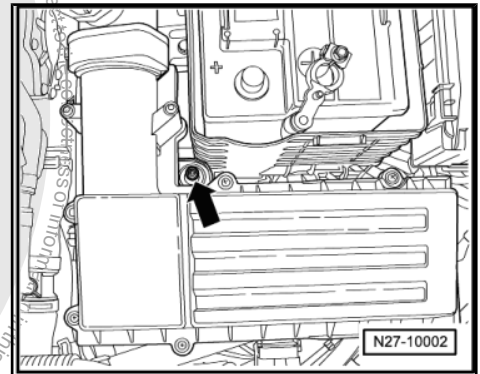

- Unlock lugs -arrows- and take cover off.

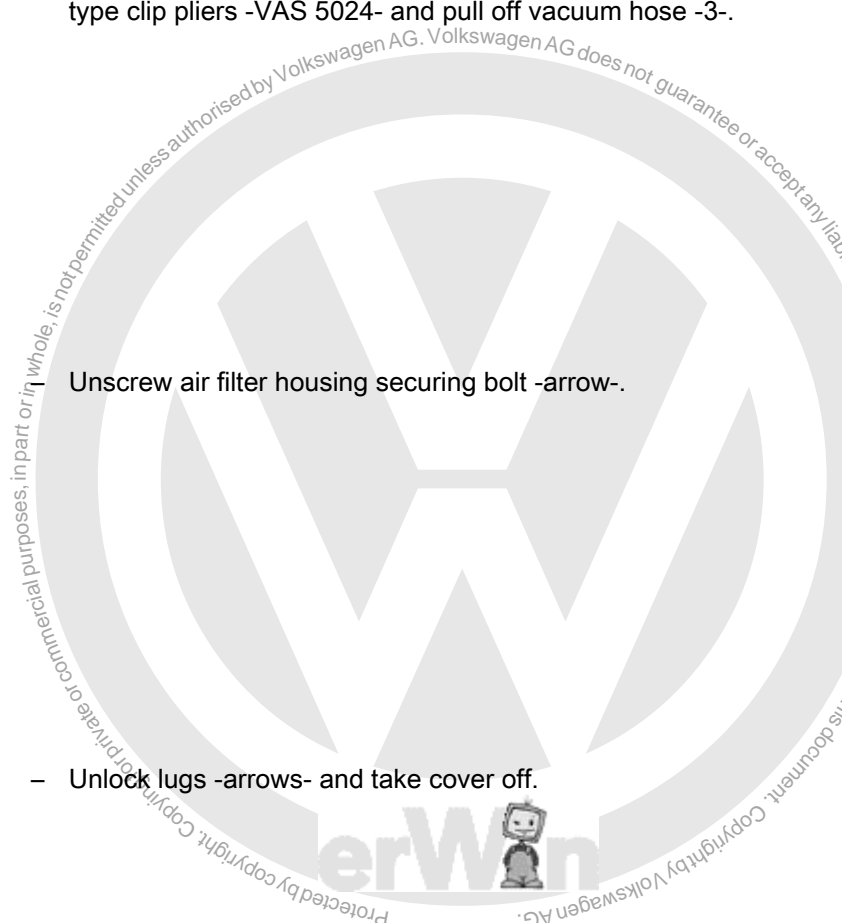
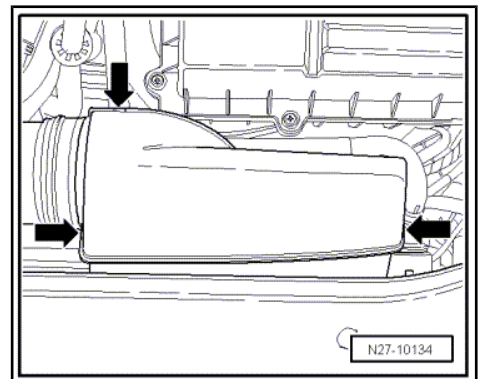



- Pull hose -arrow- off air filter housing and take hose out.
- Pull air filter housing upwards out of brackets and remove.

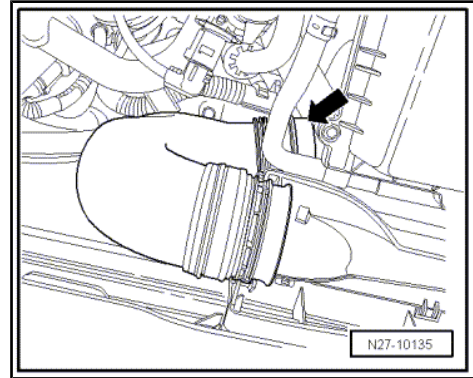

- Push down protective cap in -direction of arrow- from solenoid switch.

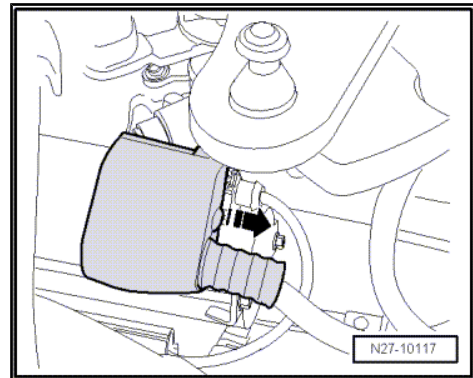

- Unscrew positive wire -1- and disconnect connector from terminal 50 -2-.

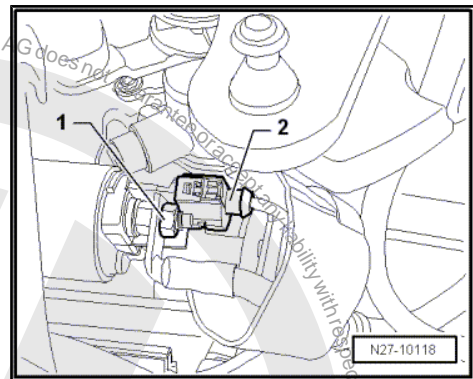

- Unclip hose -1- from hose retainer -2-.

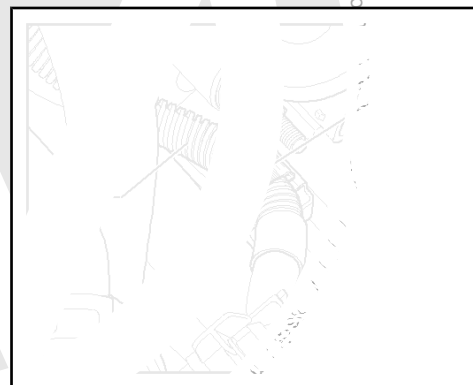



- Remove upper securing bolt of starter -arrow-.

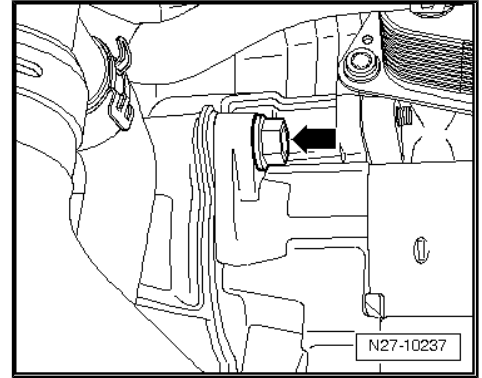

- Remove lower securing bolt of starter -arrow-.
- Remove starter from vehicle upwards.

Installing:

Installation is carried out in the reverse order. When installing, note the following:

- Tighten threaded connections to specified torque settings
=> [page 97](#) .

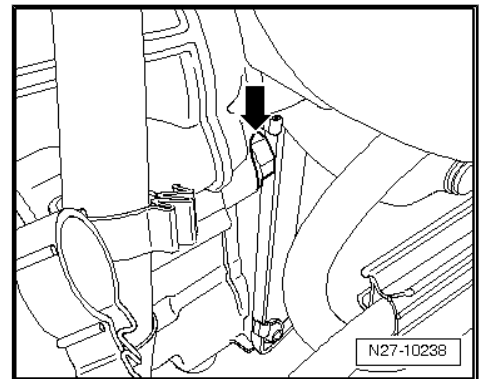



7.4 Removing and installing starter, manual gearbox

7.4.1 Vehicles with 1.6 l engine

Special tools and workshop equipment required

- ◆ Torque wrench -V.A.G 1331-
- ◆ Torque wrench -V.A.G 1332-
- ◆ Spring-type clip pliers -VAS 5024-

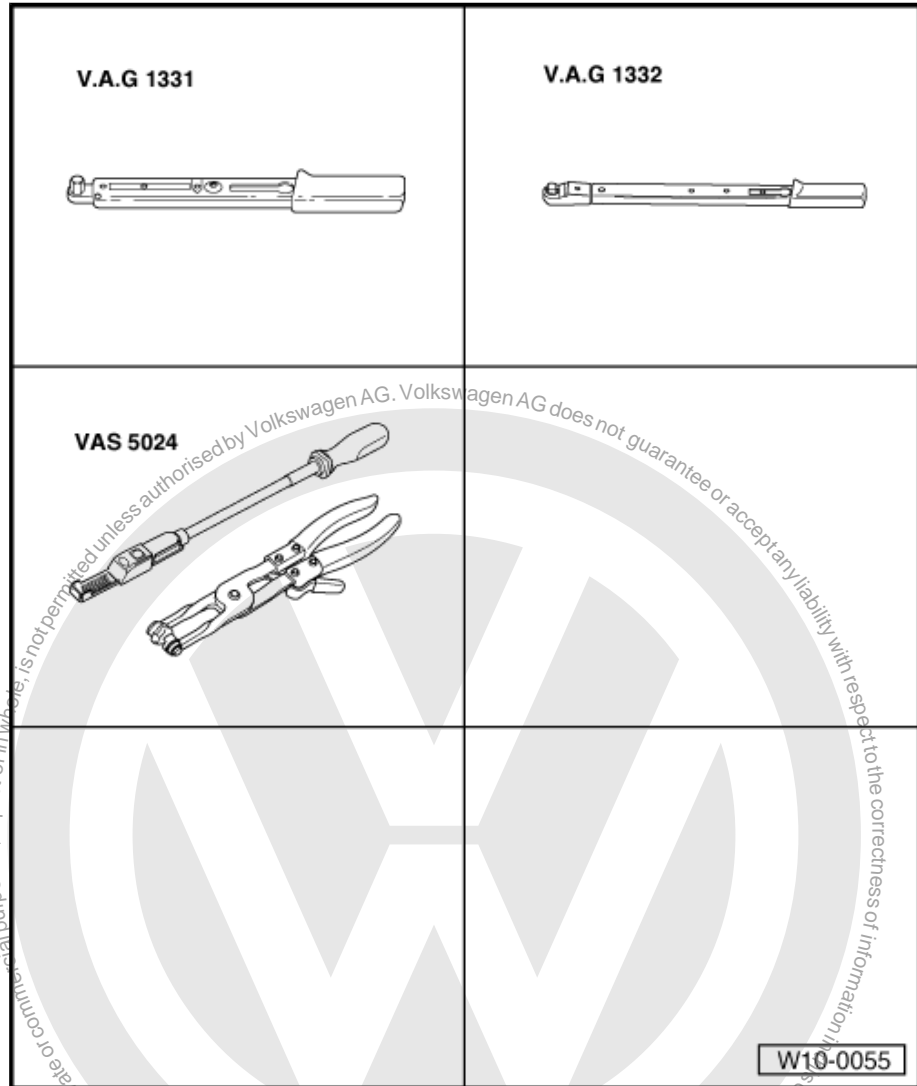

Removing:

- Disconnect the battery ⇒ [page 29](#) .
- Push down protective cap -direction of arrow- from solenoid switch.

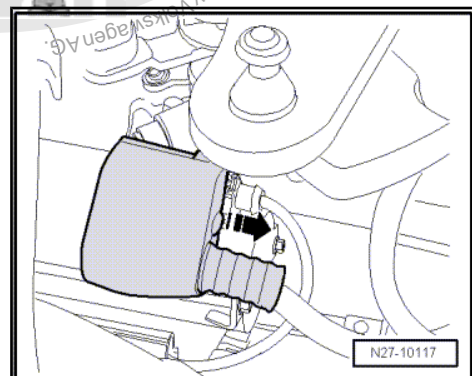



- Unscrew positive wire -1- and disconnect connector from terminal 50 -2-.

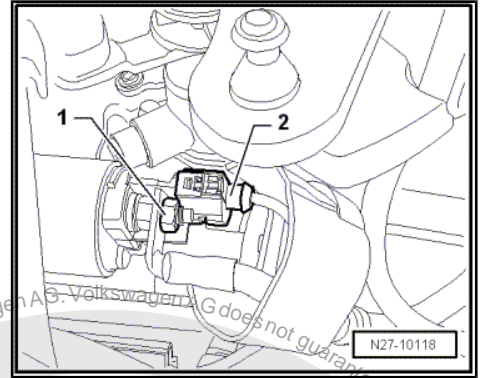

- Unscrew earth wire from starter securing bolt -arrow-.

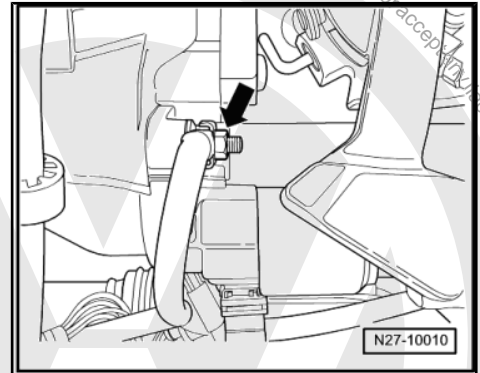

- Unscrew starter securing bolt -arrow-
- Remove noise insulation ⇒ General Body Repairs, Exterior; Rep. Gr. 50 ; Body front; Noise insulation .

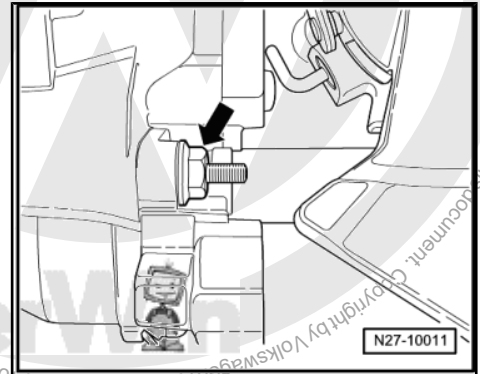

- Unscrew nut -1- from lower starter securing bolt.
- Remove wiring retainer -2-.

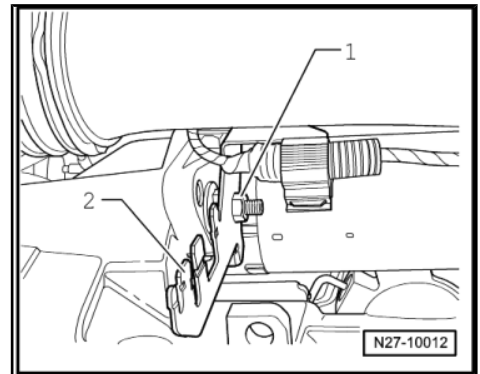



- Unscrew starter securing bolt -arrow-.
- Remove starter.

Installing:

Installation is carried out in the reverse order. When installing, note the following:

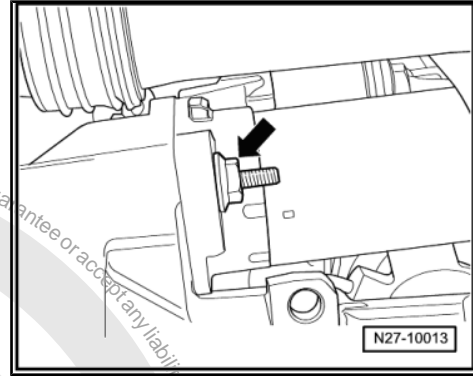

- Tighten threaded connections to specified torque settings
⇒ [page 97](#) .



7.4.2 Vehicles with 2,0 I FSI engine

Special tools and workshop equipment required

- ◆ Torque wrench -V.A.G 1331-
- ◆ Torque wrench -V.A.G 1332-
- ◆ Spring-type clip pliers -VAS 5024-

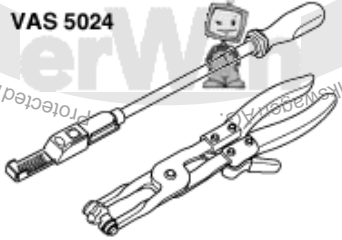
<p>V.A.G 1331</p> 	<p>V.A.G 1332</p> 
<p>VAS 5024</p> 	
	<p>W10-0055</p>



Removing:

- Disconnect the battery ⇒ [page 29](#) .
- Disconnect connector -arrow-.

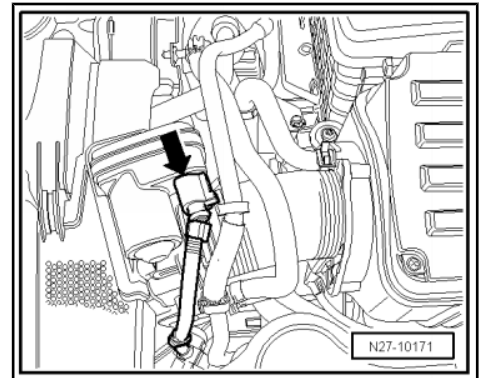

- Unclip vacuum hose from its mounting -arrow-.

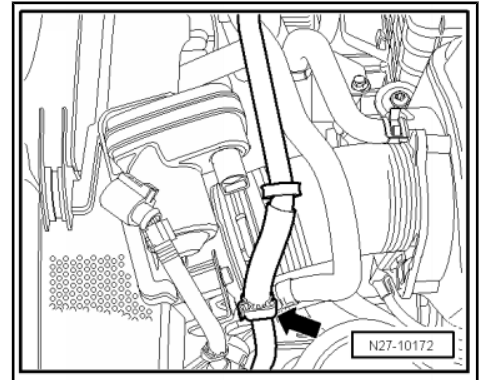

- Loosen spring-type clip -arrow- from hose -1- using spring type clip pliers -VAS 5024-.
- Pull hose -1- off air filter housing.

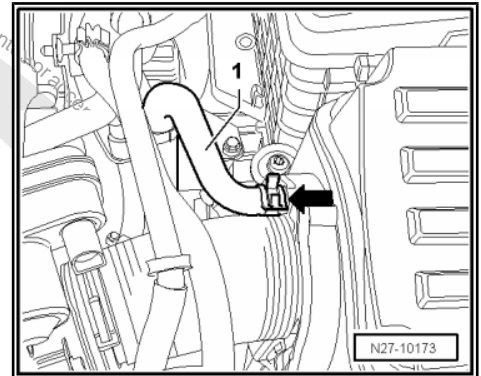

- Open retainer -arrow- on front side of air filter housing and take hose -1- off.

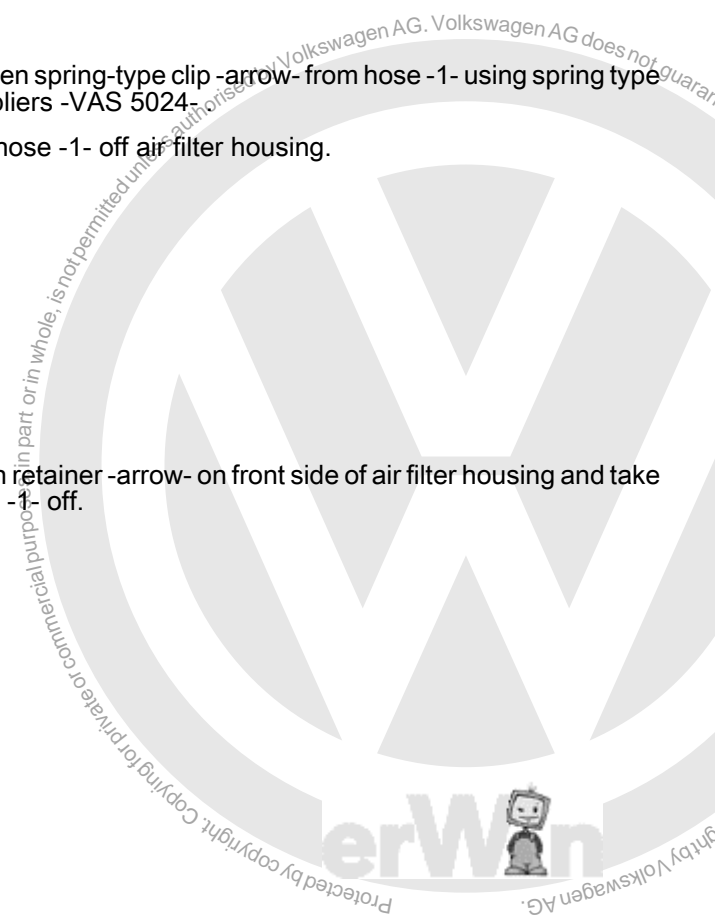
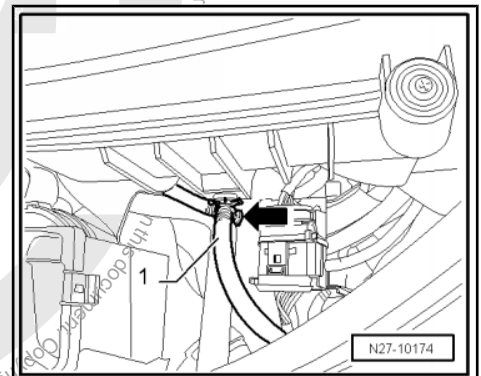



- Unscrew air filter housing securing bolt -arrow-.

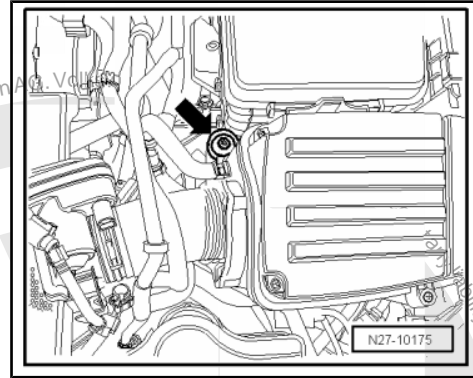

- Pull air filter housing on right side upwards off rubber mounting -arrow-.
- Loosen spring-type clip -1- using spring type clip pliers -VAS 5024- .

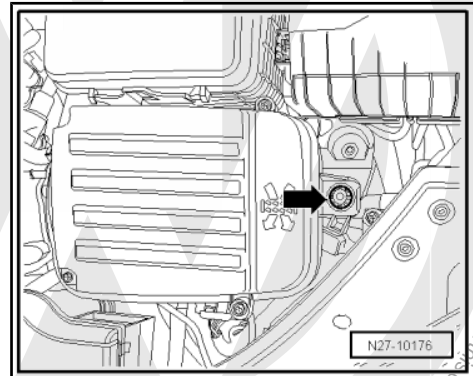

- Pull hose -2- off pipe union.
- Carefully lift air filter housing upwards out of the vehicle taking into consideration the length of the hose.

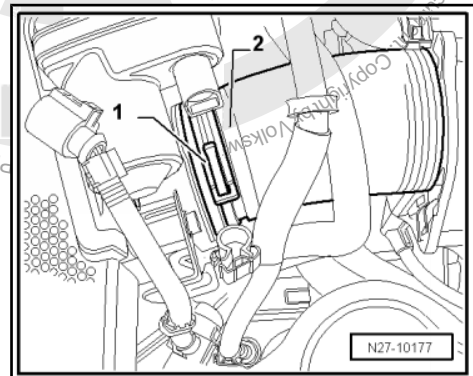

- Separate connector -arrow- on rear of air filter housing.

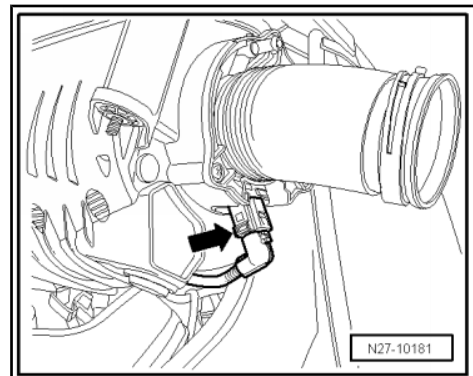



- Remove air filter housing from vehicle.
- Push down protective cap in -direction of arrow- from solenoid switch.

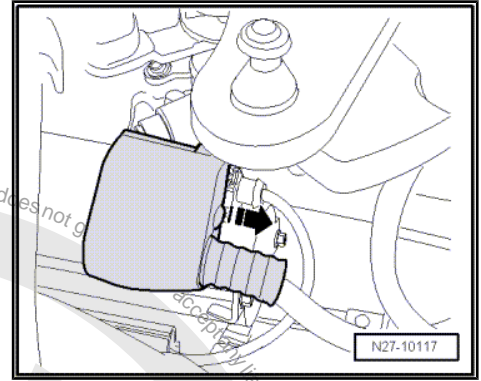

- Unscrew positive wire -1- and disconnect connector from terminal 50 -2-.

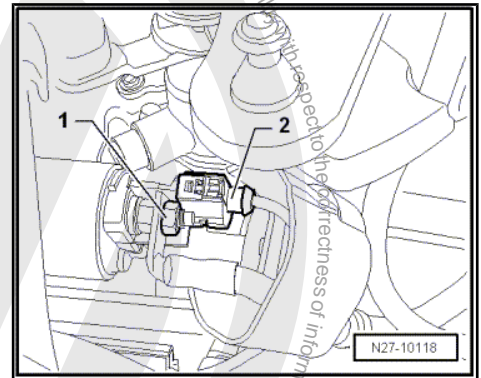

- Unscrew earth wire from starter securing bolt -arrow-.

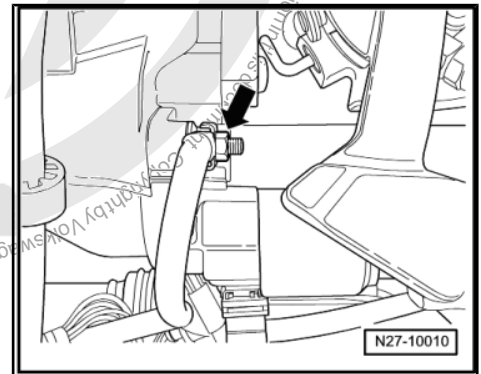

- Unscrew starter securing bolt -arrow-.
- Remove noise insulation => General Body Repairs, Exterior; Rep. Gr. 50 ; Body front; Noise insulation .

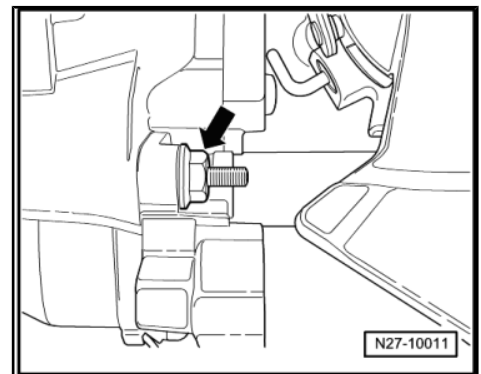



- Unscrew securing nut -1- from lower starter securing bolt.
- Remove wiring retainer -2-.

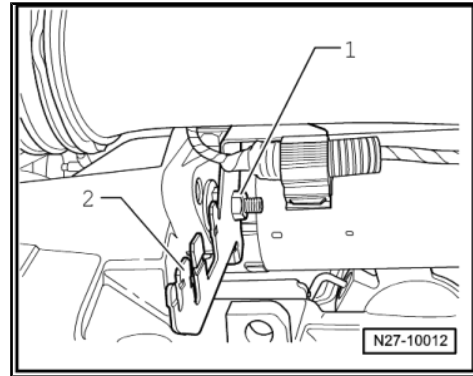

- Unscrew starter securing bolt -arrow-.
- Remove starter from vehicle downwards.

Installing:

Installation is carried out in the reverse order. When installing, note the following:

- Tighten threaded connections to specified torque settings
=> [page 97](#) .

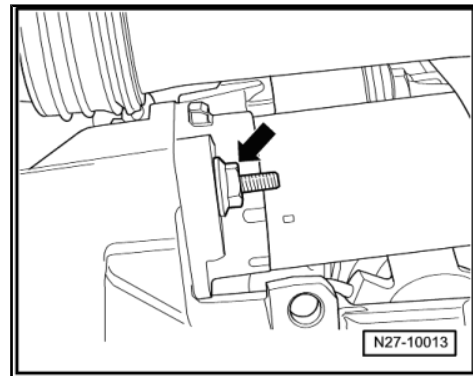



7.4.3 Vehicles with 2.0 I FSI turbo engine

Special tools and workshop equipment required

- ◆ Torque wrench -V.A.G 1331-
- ◆ Torque wrench -V.A.G 1332-
- ◆ Spring-type clip pliers -VAS 5024-

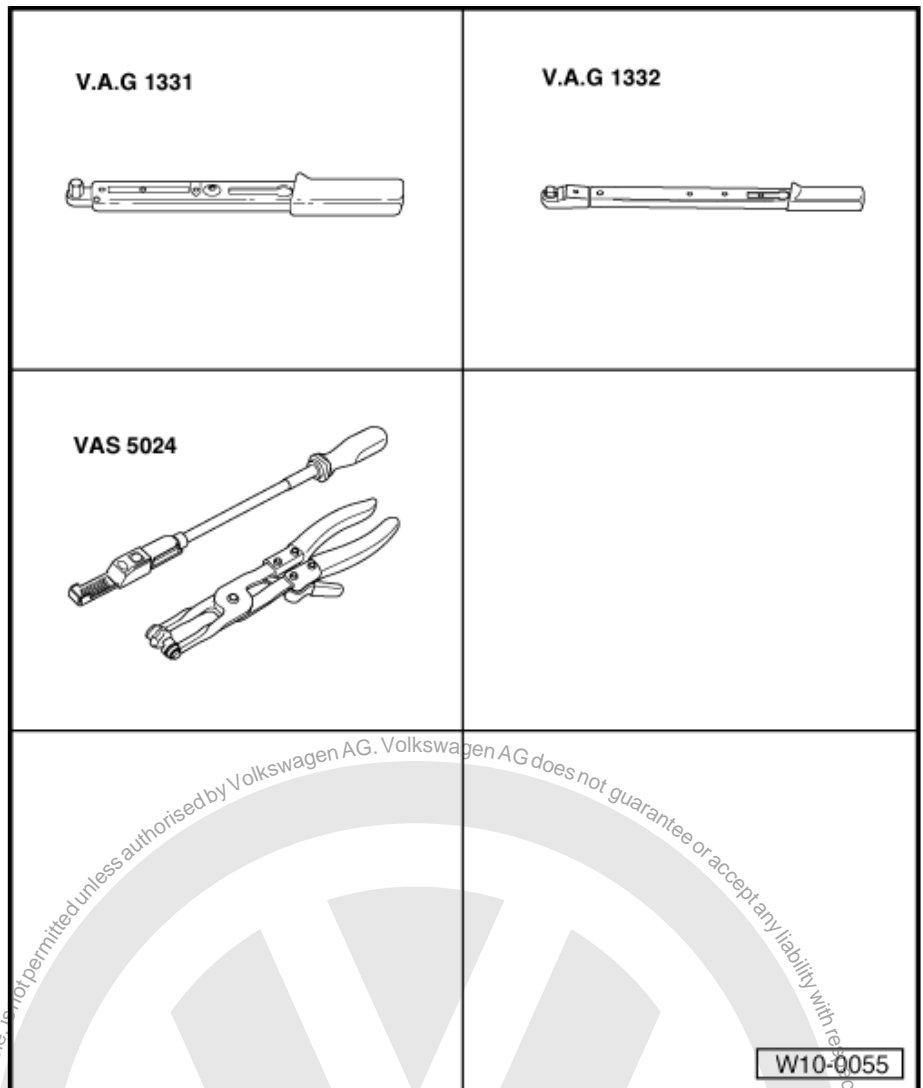

Removing:

- Disconnect the battery ⇒ [page 29](#) .
- Unbolt securing bolts -arrow-.

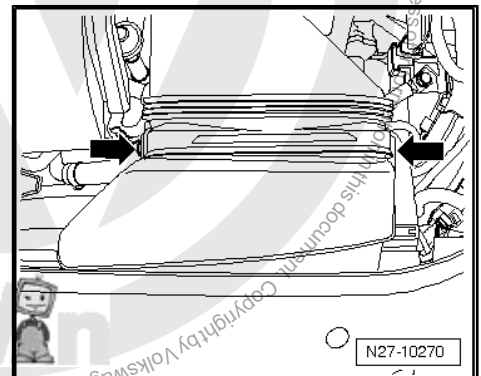



- Disconnect connector -arrow-.

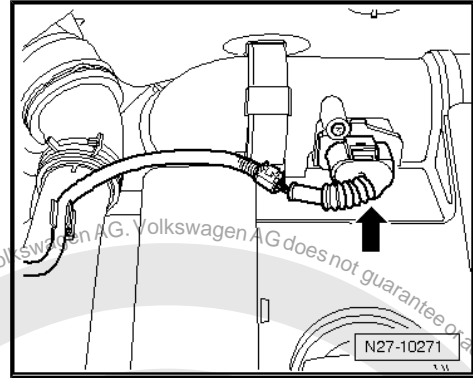

- Loosen spring-type clips -1- using spring type clip pliers -VAS 5024 A- .

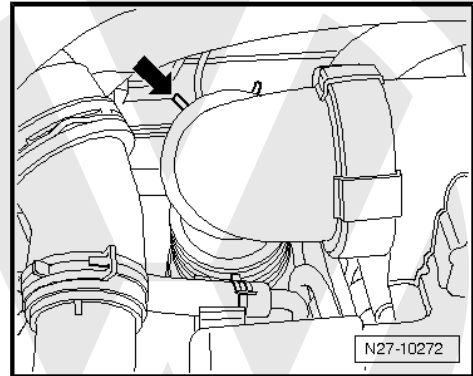

- Pull engine cover off upwards -arrows-.

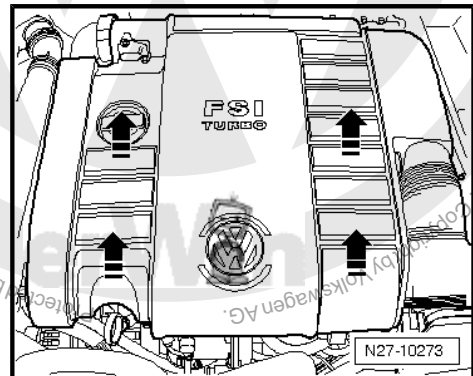

- Push down protective cap in -direction of arrow- from solenoid switch.

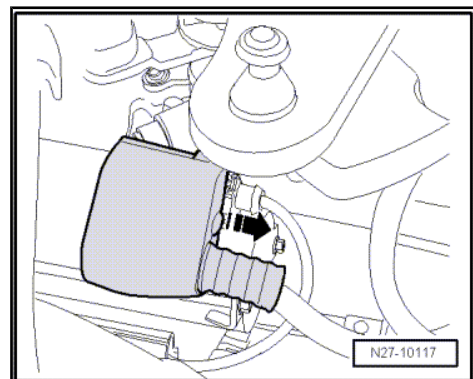



- Unscrew positive wire -1- and disconnect connector from terminal 50 -2-.

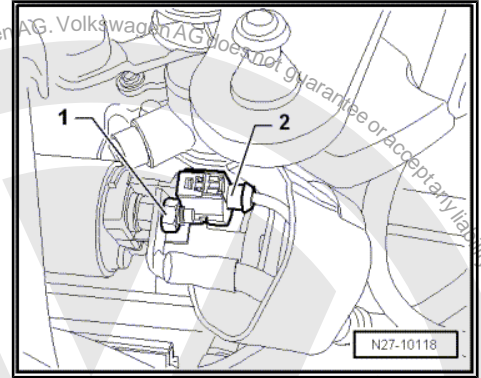

- Unscrew earth wire from starter securing bolt -arrow-.

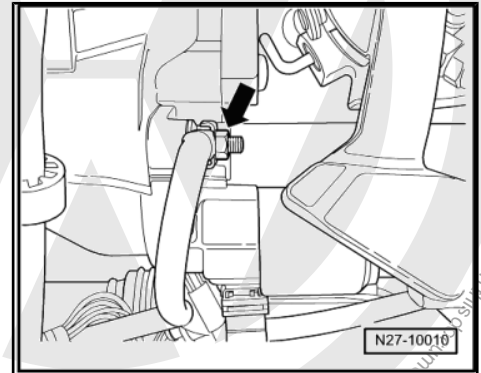

- Unscrew starter securing bolt -arrow-.
- Remove noise insulation ⇒ General Body Repairs, Exterior; Rep. Gr. 50 ; Body front; Noise insulation .

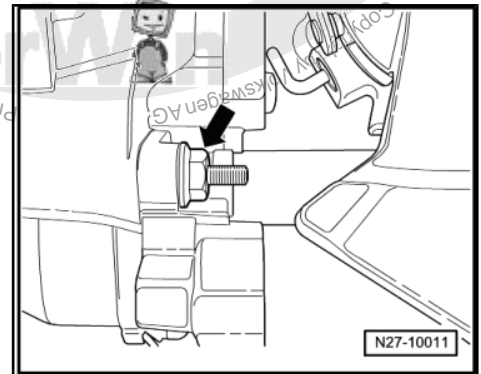

- Unscrew securing nut -1- from lower starter securing bolt.
- Remove wiring retainer -2-.

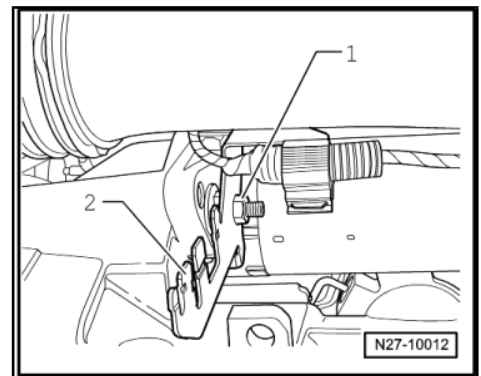



- Unscrew starter securing bolt -arrow-.
- Remove starter from vehicle downwards.

Installing:

Installation is carried out in the reverse order. When installing, note the following:

- Tighten threaded connections to specified torque settings
⇒ [page 97](#) .

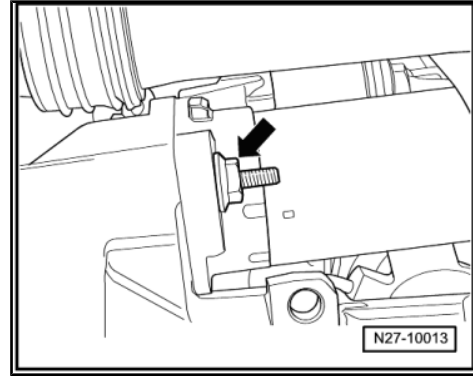

7.4.4 Vehicles with 2.5 l engine

Special tools and workshop equipment required

- ◆ Torque wrench -V.A.G 1331-
- ◆ Torque wrench -V.A.G 1332-
- ◆ Spring-type clip pliers -VAS 5024-

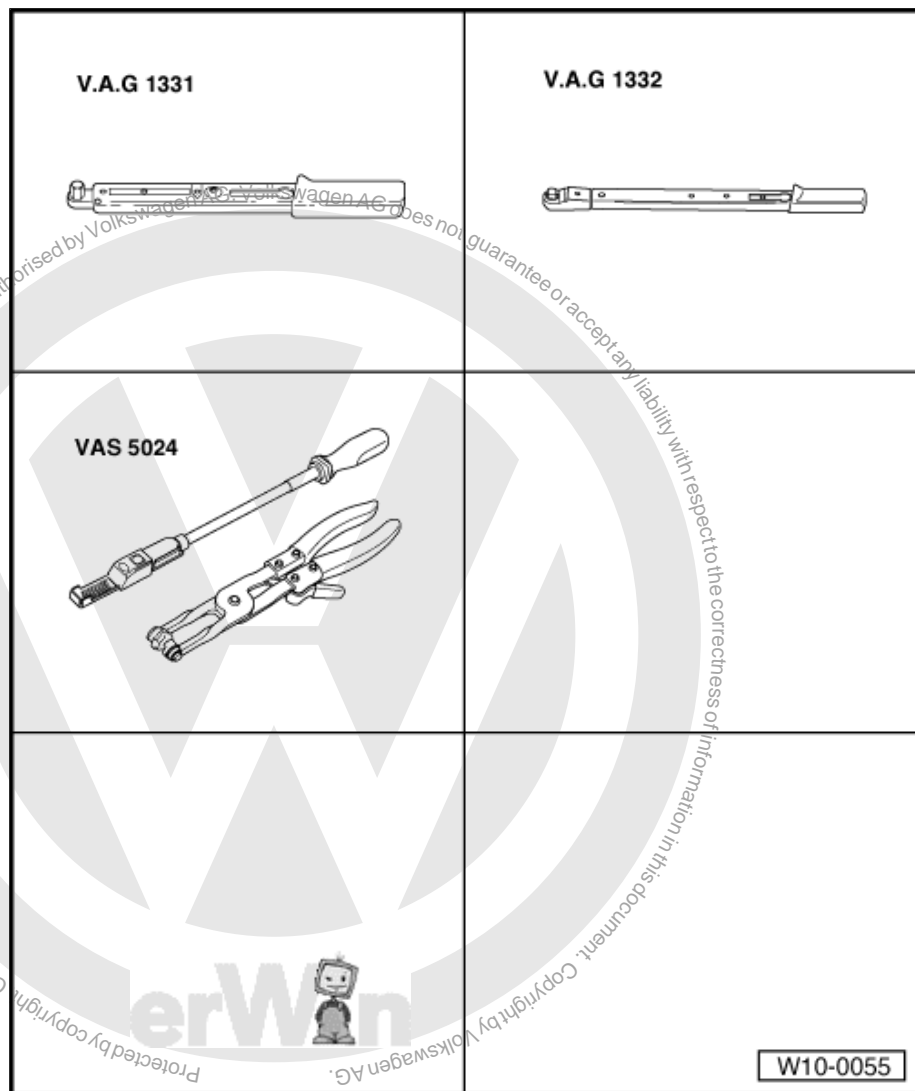

Removing:

- Disconnect the battery ⇒ [page 29](#) .



- Pull engine cover off upwards -arrows-.

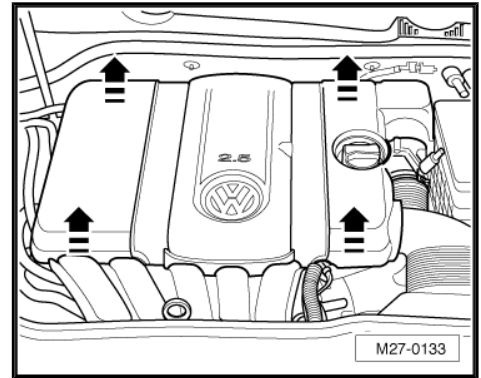

- Separate connector -1-, release spring-type clip -2- with spring type clip pliers -VAS 5024- and pull off vacuum hose -3-.

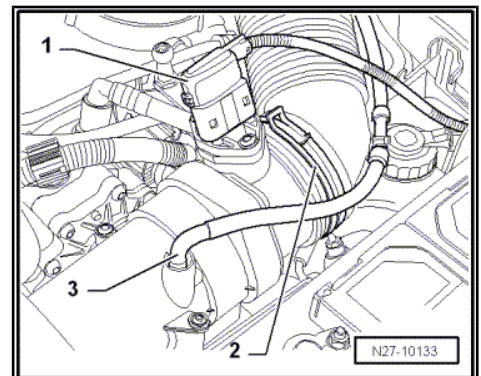

- Push down protective cap -direction of arrow- from solenoid switch.

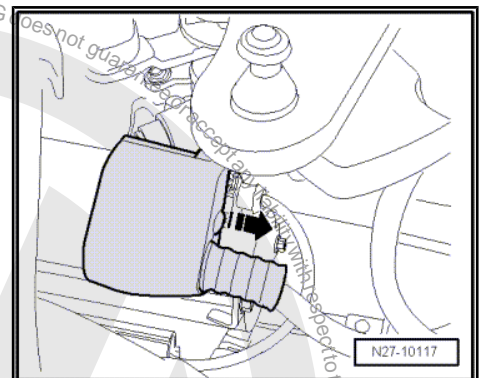

- Unscrew positive wire -1- and disconnect connector from terminal 50 -2-.

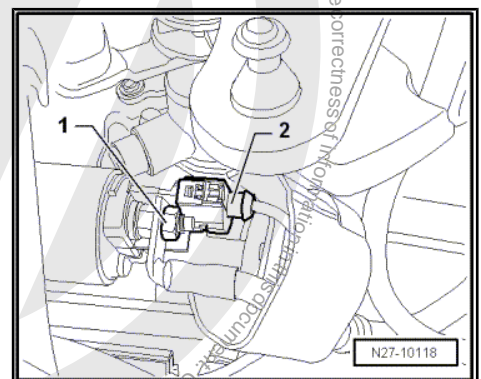

Protected by copyright. Copying for private or commercial purposes, in part or in whole, is not permitted unless authorised by Volkswagen AG. Volkswagen AG does not guarantee the correctness of the information.



- Unscrew earth wire from starter securing bolt -arrow-

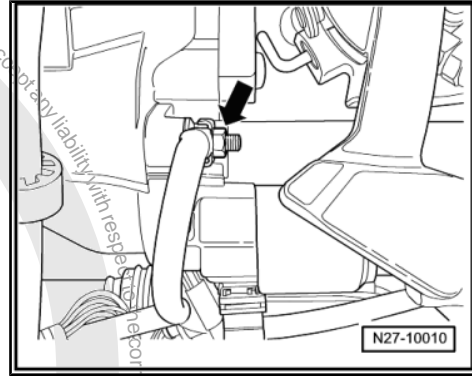

- Unscrew starter securing bolt -arrow-
- Remove noise insulation ⇒ General Body Repairs, Exterior; Rep. Gr. 50 ; Body front; Noise insulation .

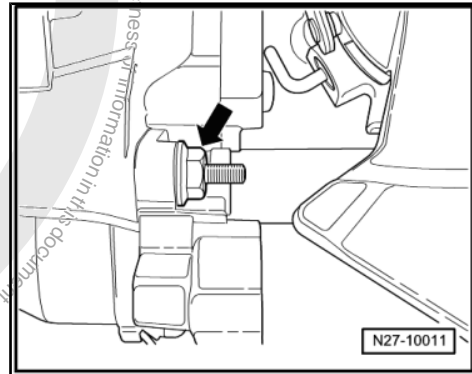

- Unscrew nut -1- from lower starter securing bolt.
- Remove wiring retainer -2-

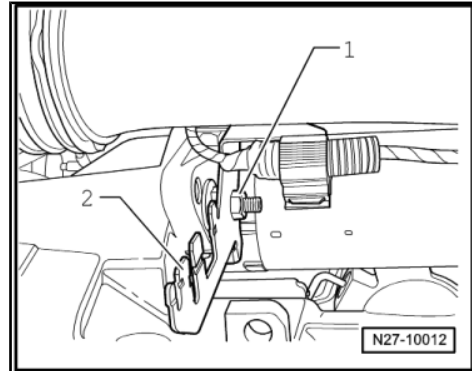

- Unscrew starter securing bolt -arrow-
- Remove starter.

Installing:

Installation is carried out in the reverse order. When installing, note the following:

- Tighten threaded connections to specified torque settings ⇒ [page 97](#) .

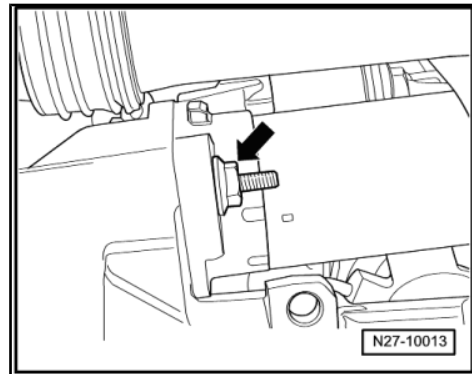



7.4.5 Vehicles with 1.9 l TDI engine

Special tools and workshop equipment required

- ◆ Torque wrench -V.A.G 1331-
- ◆ Torque wrench -V.A.G 1332-
- ◆ Spring-type clip pliers -VAS 5024-

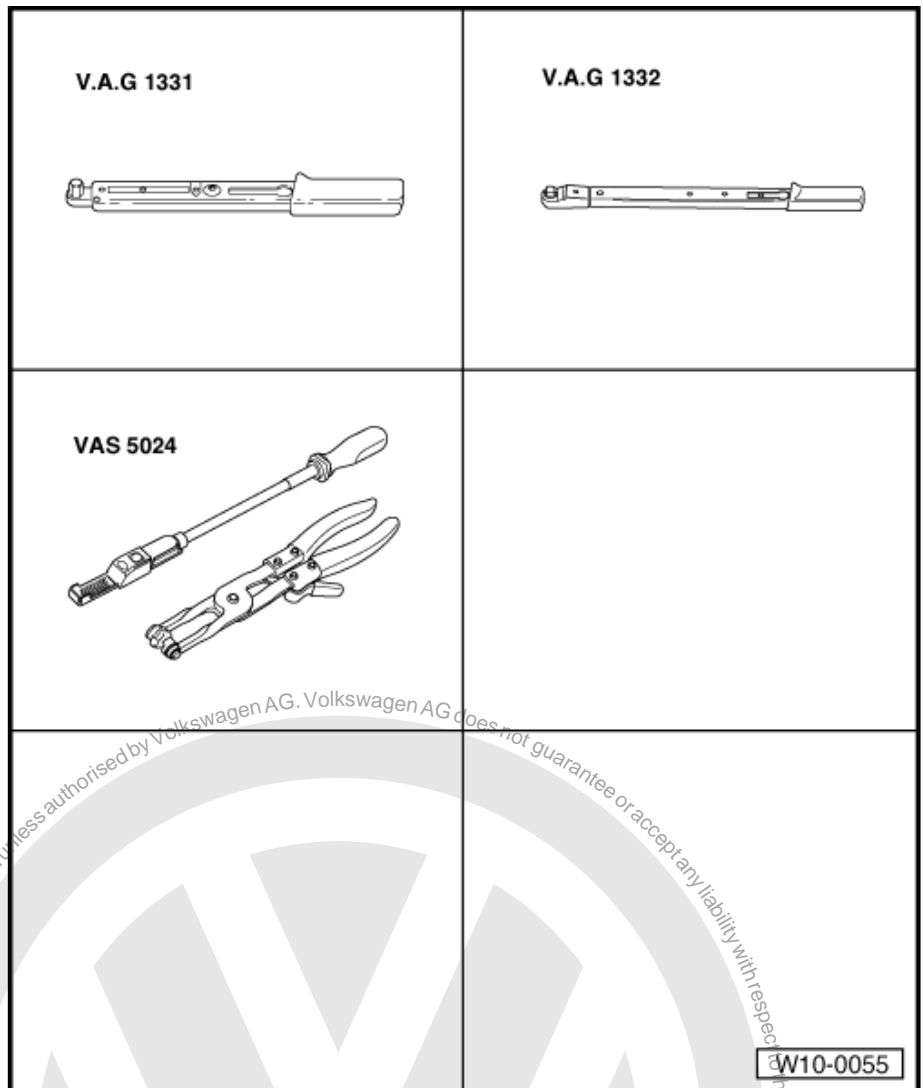

Removing:

- Disconnect the battery ⇒ [page 29](#) .
- Pull engine cover upwards -arrows A- and forwards -arrow B-.

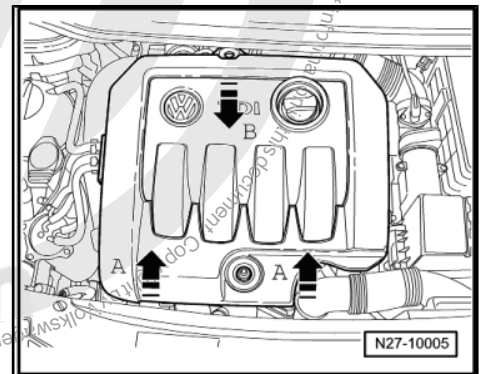



- Disconnect connector -1- and loosen spring type clip -2- with spring type clip pliers -VAS 5024- .

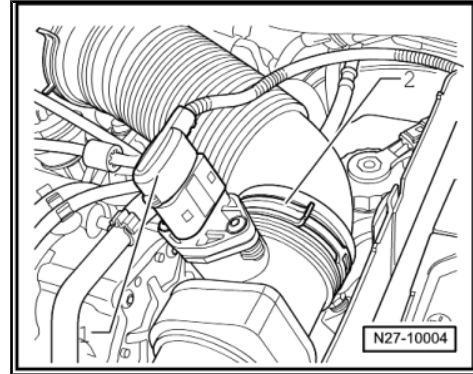

- Pull the vacuum hose -arrow- off air filter housing.

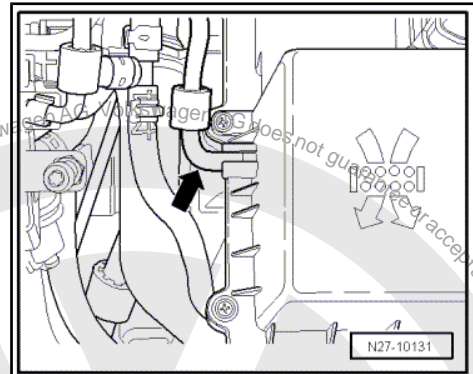

- Unscrew air filter housing securing bolt -arrow-.

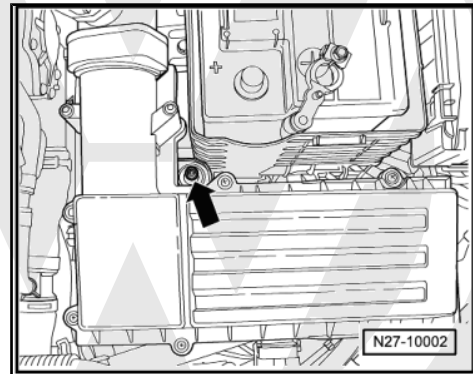

- Unlock lugs -arrows- and take cover off.

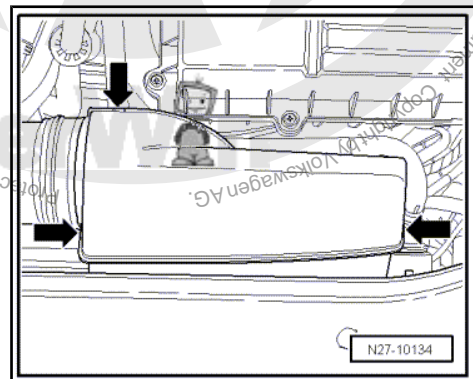



- Pull hose -arrow- off air filter housing and take hose out.
- Pull air filter housing upwards out of brackets and remove.

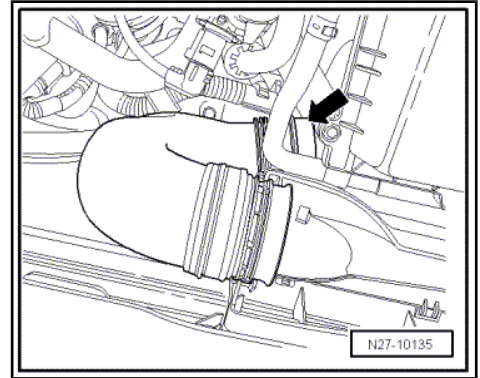

- Push down protective cap -direction of arrow- from solenoid switch.

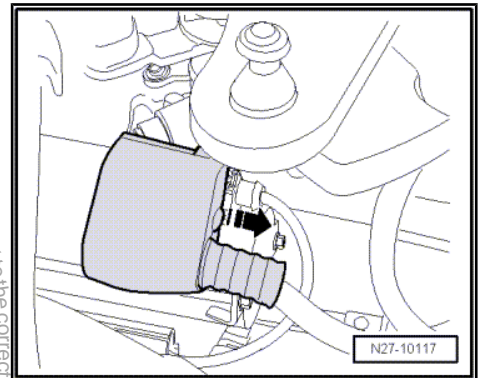

- Unscrew positive wire -1- and disconnect connector from terminal 50 -2-.

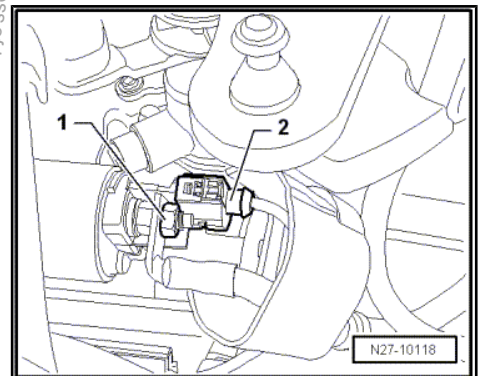

- Unscrew earth wire from starter securing bolt -arrow-.

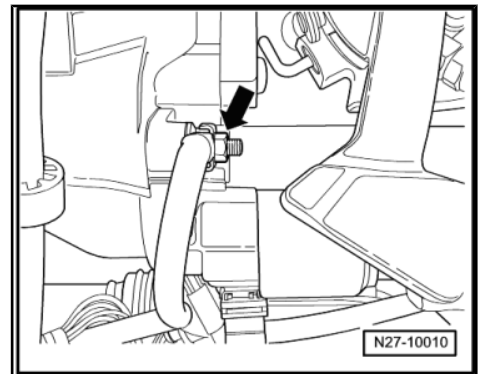



- Unscrew starter securing bolt -arrow-.
- Remove noise insulation => General Body Repairs, Exterior; Rep. Gr. 50 ; Body front; Noise insulation .

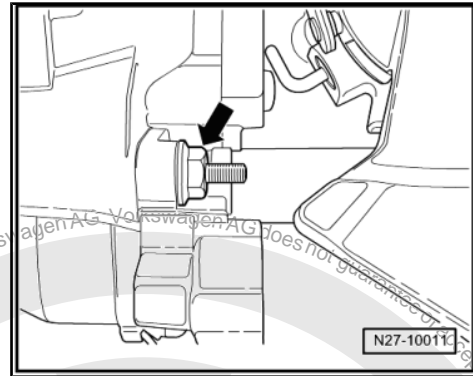

- Unscrew nut -1- from lower starter securing bolt.
- Remove wiring retainer -2-.

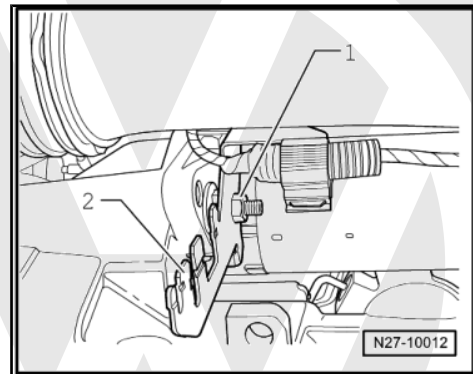

- Unscrew starter securing bolt -arrow-.
- Remove starter.

Installing:

Installation is carried out in the reverse order. When installing, note the following:

- Tighten threaded connections to specified torque settings
=> [page 97](#) .

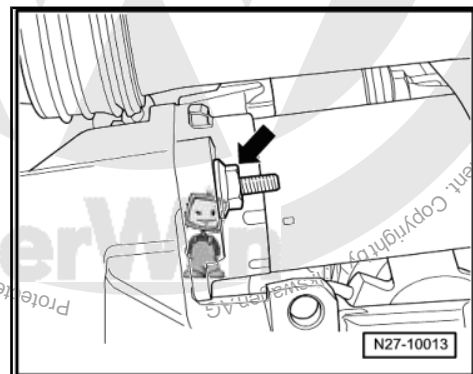



7.4.6 Vehicles with 2.0 l SDI engine

Special tools and workshop equipment required

- ◆ Torque wrench -V.A.G 1331-
- ◆ Torque wrench -V.A.G 1332-
- ◆ Spring-type clip pliers -VAS 5024-

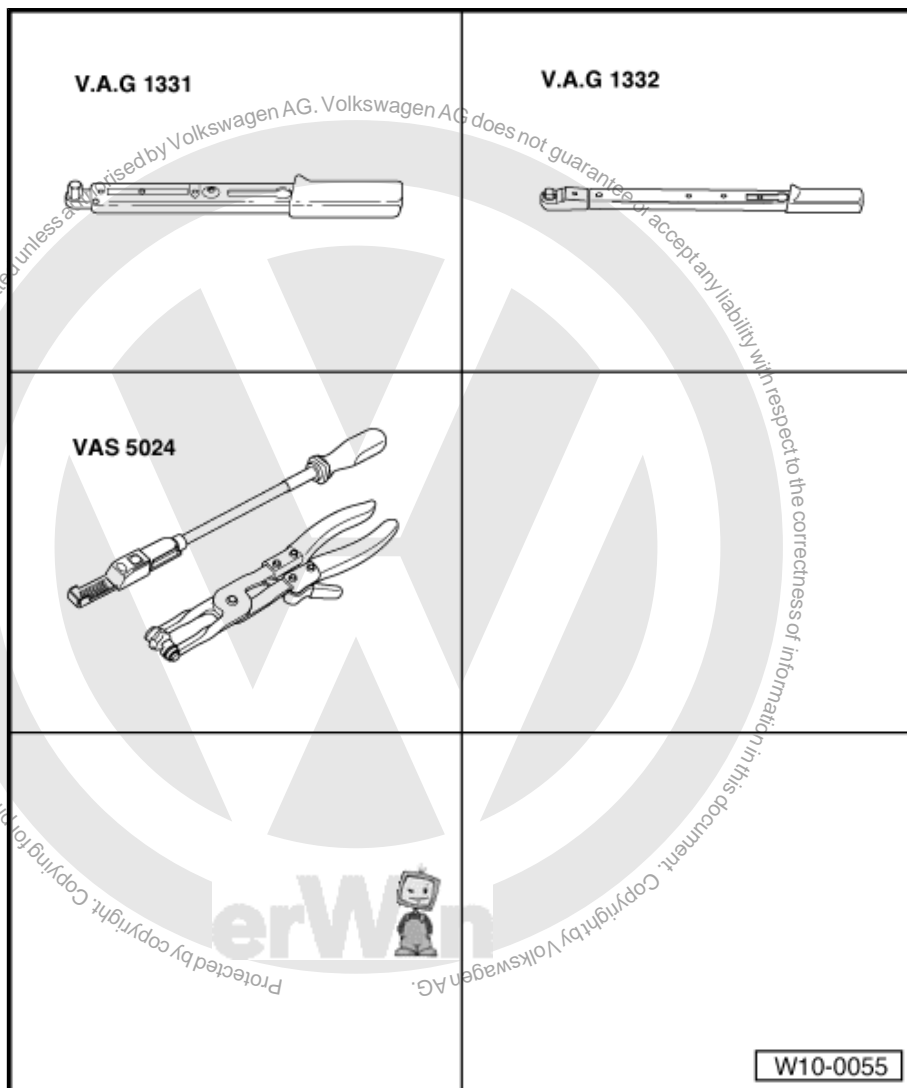

Removing:

- Disconnect the battery ⇒ [page 29](#) .
- Pull engine cover upwards -arrows A- and forwards -arrow B-.

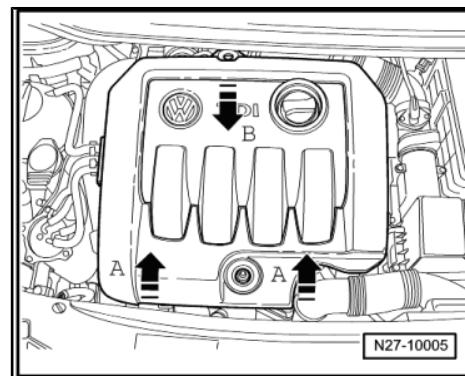



- Release spring-type clip -1- using spring type clip pliers -VAS 5024- and disconnect connector -2-.
- Remove securing bolt -3-.

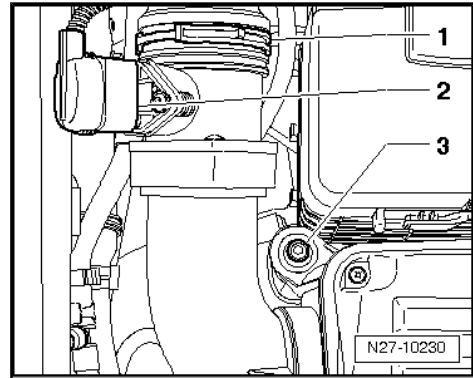

- Pull vacuum hose off -arrow-.

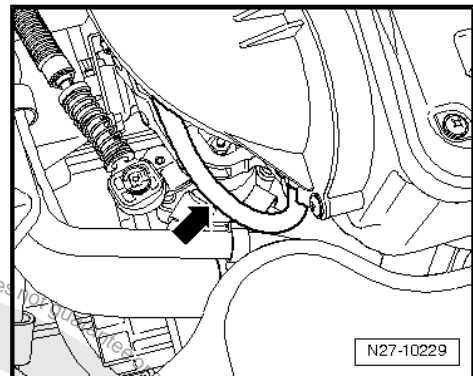

- Pull air filter housing on right side upwards off rubber mounting -arrow-.
- Remove air filter housing from vehicle.

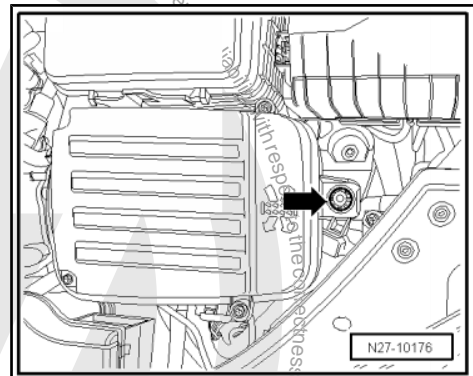

- Push down protective cap -direction of arrow- from solenoid switch.

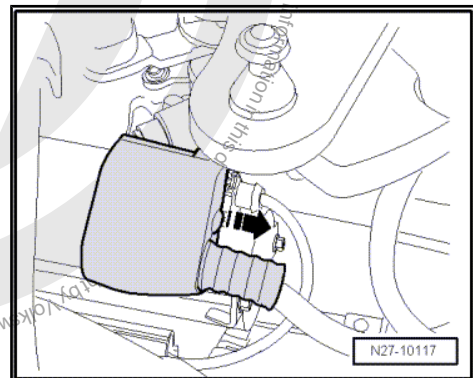



- Unscrew positive wire -1- and disconnect connector from terminal 50 -2-.

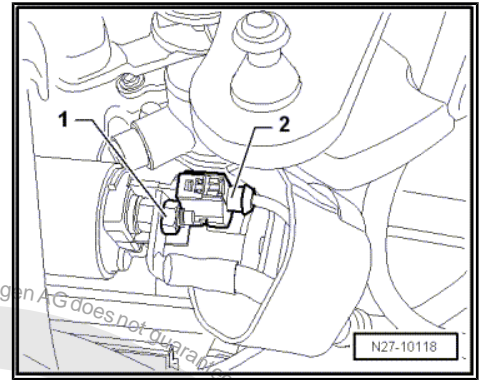

- Unscrew earth wire from starter securing bolt -arrow-.

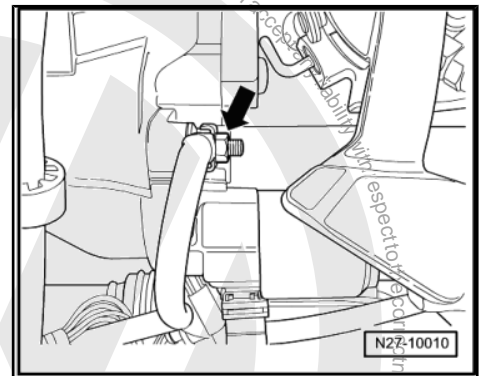

- Unscrew starter securing bolt -arrow-.
- Remove noise insulation -> General Body Repairs, Exterior; Rep. Gr. 50 ; Body front; Noise insulation .

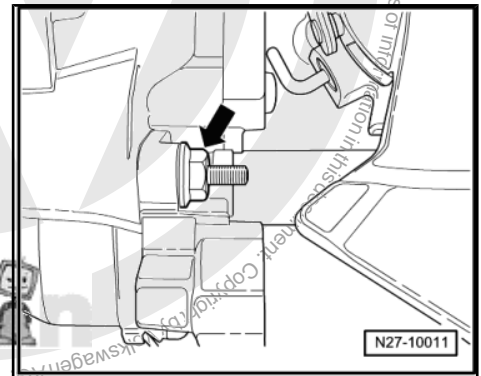

- Unscrew nut -1- from lower starter securing bolt.
- Remove wiring retainer -2-.

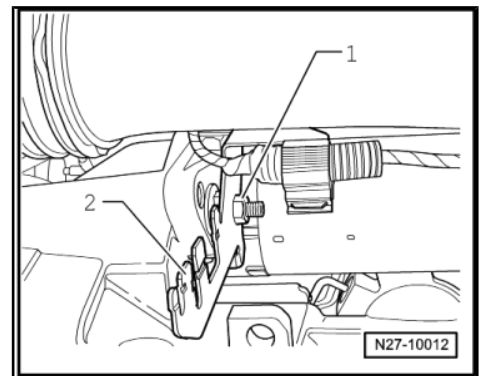



- Unscrew starter securing bolt -arrow-.
- Remove starter.

Installing:

Installation is carried out in the reverse order. When installing, note the following:

- Tighten threaded connections to specified torque settings
⇒ [page 97](#) .

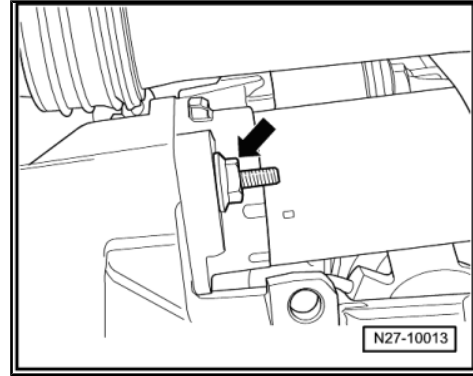



8 Torque settings: starter

Threaded connections		Torque settings
Starters on automatic, manual gearboxes	M12	75 Nm
Starter on automated shift gearboxes	M10	60 Nm
Earthing wire to starter securing bolt	M8	15 Nm
Wiring retainer on starter securing bolt	M8	15 Nm
Positive wire to starter solenoid switch	M8	15 Nm
Air filter housing to body		10 Nm
Earthing wire to automatic gearbox	M8	15 Nm





9 Alternator



Caution

Disconnecting and connecting the battery as described in the Workshop Manual => [page 29](#).

9.1 Fastening B+ wire to alternator



Caution

If the B+ wire is not secured with the prescribed torque the following may occur:

- ◆ *Battery not charge fully.*
- ◆ *Vehicle electrics/electronics fail completely (breakdown).*
- ◆ *Danger of fires from sparks.*
- ◆ *Damage to electronic components and control units due to excessive voltage.*

- The tightening torque for the securing nut of the B+ wire -arrow- can be found in the following table "Tightening torques" => [page 145](#).

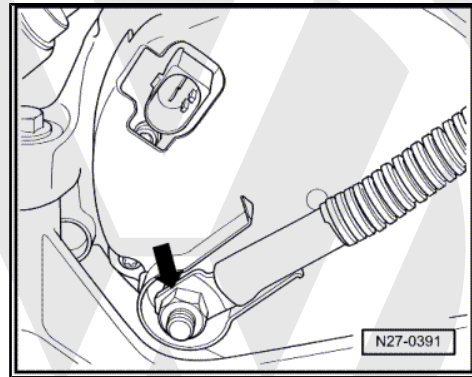

9.2 Checking ribbed belt (poly V-belt)

- Crank engine at vibration damper/belt pulley using a socket.
- Fit ribbed belt (poly V-belt).
- ◆ Sub-surface cracks (cracks, core ruptures, cross sectional breaks)
- ◆ Layer separation (top layer, draw strands)
- ◆ chassis breakout
- ◆ Fraying of cord strands
- ◆ Flank wear (material wear, frayed flanks, flank brittleness (glassy flanks), surface cracks)
- ◆ Traces of oil and grease



Caution

It is essential to renew poly V-belt if faults are found. This will avoid possible break-downs or operating problems.



9.3 Check alternator -C-

- Connect Vehicle Diagnosis, Testing and Information System -VAS 5051A- → [page 281](#) .

Select "guided fault finding" in Vehicle Diagnosis, Testing and Information System -VAS 5051A- .

- Using the "Go to" key, select "Function/component selection" and the following menu items one after the other:

- ◆ Body
- ◆ Electrical System
- ◆ 27 - Starter, current supply
- ◆ Electrical components
- ◆ C - Alternator

9.4 Alternator, 16 I injection engine

9.4.1 Assembly overview

1 - Hexagon head collared bolt

- M8x108
- 23 Nm

2 - Hexagon head collared bolts

- M8x50
- 23 Nm

3 - Bracket

4 - Hexagon head collared nut

- M8

5 - Hexagon head collared bolts

- M8x45
- 52 Nm

6 - Protective cap

7 - Hexagon head collared nut

- M8

8 - Cross-head screw

- M5x21
- 4.5 Nm

9 - Hexagon nut, flat

- M8

10 - Plain washer

- M5

11 - Phillips screws

- M4x19
- 2 Nm

12 - Cross-head screw

- M4x13

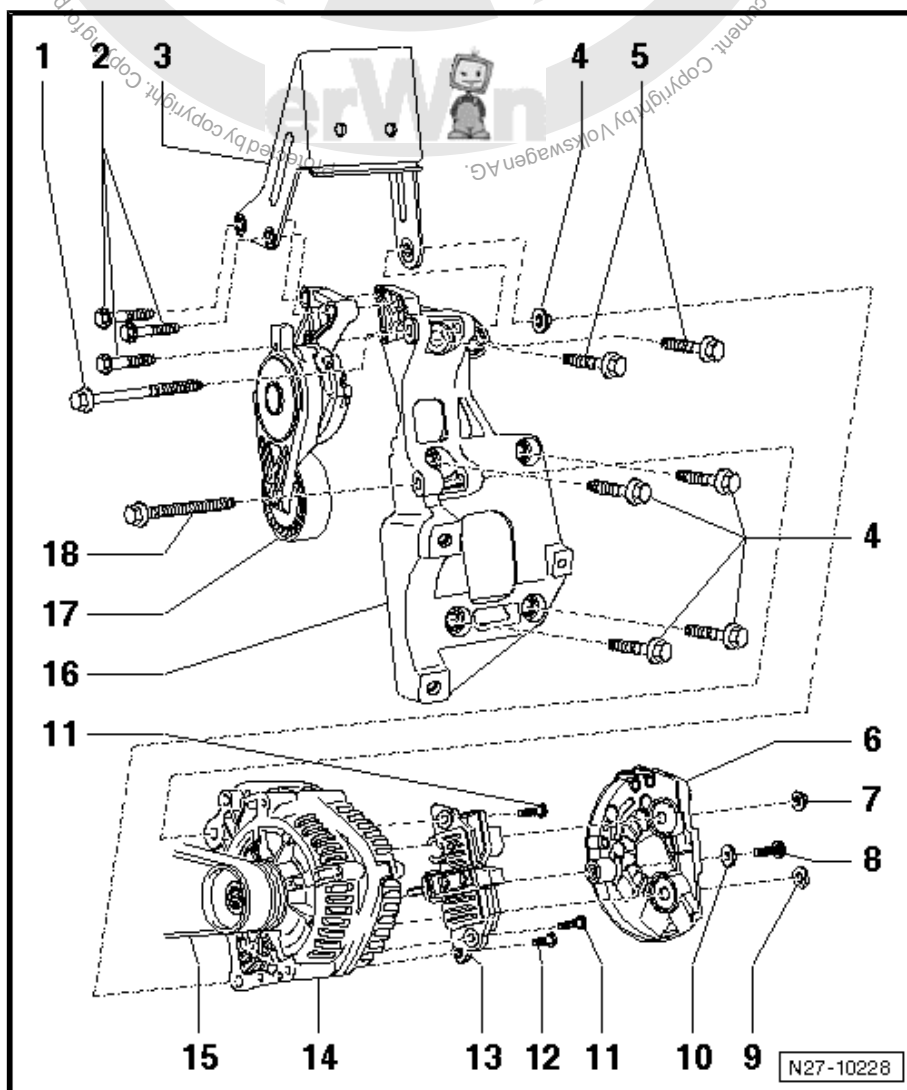



- 2 Nm

13 - Voltage regulator

- Removing and installing voltage regulator ⇒ [page 142](#)

14 - Alternator

- Removing and installing alternator ⇒ [page 100](#)

15 - Poly V-belt

- Checking ⇒ [page 98](#) .

16 - Compact bracket

- For alternator and air conditioner compressor
- Tightening sequence ⇒ [page 145](#)

17 - Tensioning element for poly V-belt

18 - Hexagon head collared bolt

- M8x90
- 23 Nm

9.4.2 Removing and installing alternator, 1.6 l injection engine



Caution

Disconnecting and connecting the battery as described in the Workshop Manual ⇒ [page 29](#) .



Special tools and workshop equipment required

- ◆ Torque wrench -V.A.G 1331-

V.A.G 1331



W00-0427

- ◆ Locking pin -T10060 A-

T10060 A

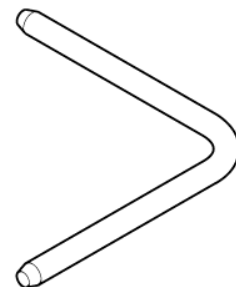

W00-10235

Removing:

- Disconnect the battery ⇒ [page 29](#) .



- Pull engine cover off upwards -arrows-.

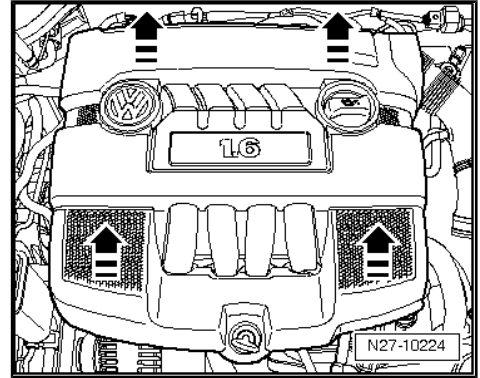

- Disconnect connector of DF wiring -1- and pull protective cap -2- off.

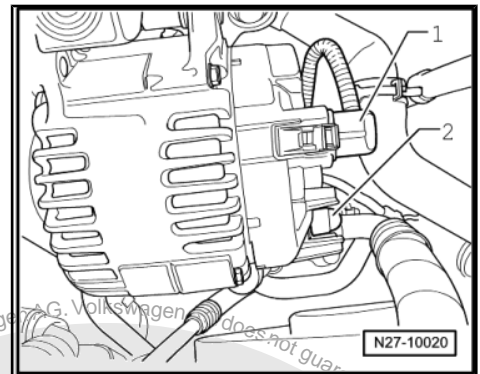

- Unscrew B+ wiring -arrow- off alternator.

 **Caution**

Mark top and direction of rotation of poly V-belt before removing. When installing observe direction of rotation marked on removal. Installing opposite to the direction of rotation leads to belt damage!

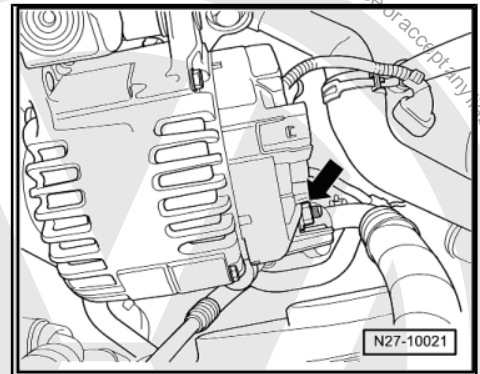

- Mark direction of rotation of poly V-belt.
- Release poly V-belt by turning the tensioning device with an open-ended spanner AF 16 in -direction of arrow-.
- Lock tensioning element with retaining pin -T10060 A- .
- Remove ribbed belt.

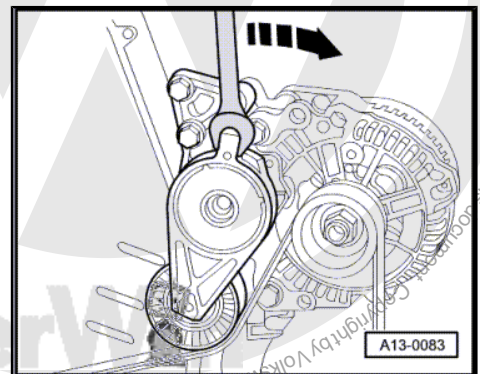



- Unclip coolant hose from hose retainer -1- and remove securing nut -2-.

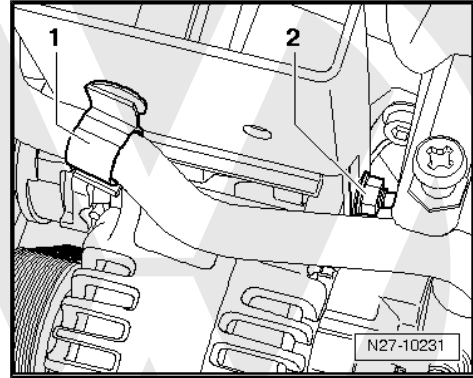

- Unbolt securing bolts -arrow-.
- Take hose retainer together with tensioning element out of the vehicle.

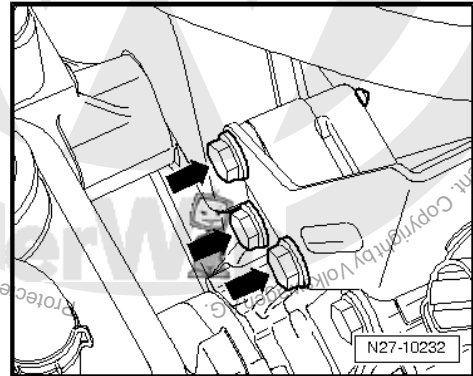

- Remove alternator securing bolts -arrows-.

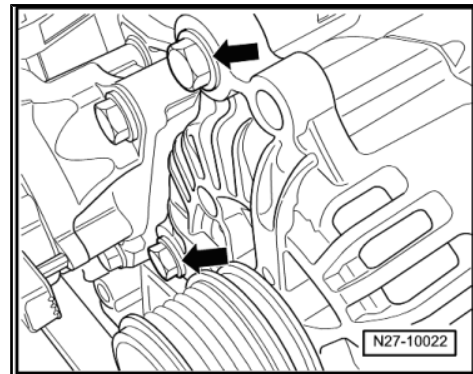

- Unscrew wiring bracket -arrow- from alternator.
- Remove alternator.

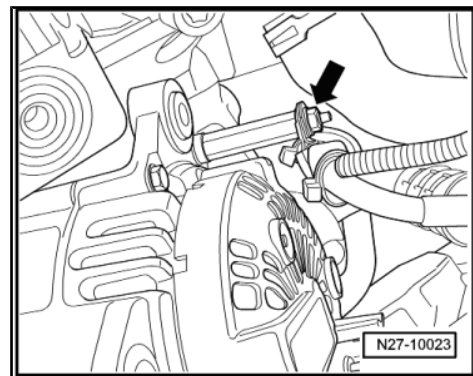

Installing:

Installation is carried out in the reverse order. When installing, note the following:



Caution

- ◆ *When reinstalling used ribbed belts (poly V-belts) observe the direction of rotation marked on removal!*
- ◆ *Ensure, before installing ribbed belt, that all ancillaries (alternator, air conditioner compressor) are secured tightly.*
- ◆ *Ensure ribbed belt (poly V-belt) is seated correctly in belt pulley when installing.*



- Drive threaded sleeves -A- out of the alternator housing for approx. 4 mm in -direction of arrow-.

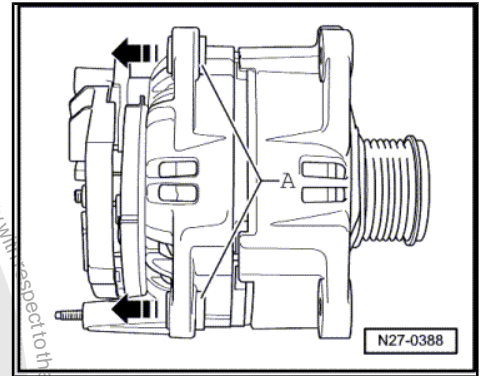

- Position wiring bracket -arrow- on rear of generator at 3 o'clock.
- Tighten threaded connections to specified torque settings
 => [page 145](#) .

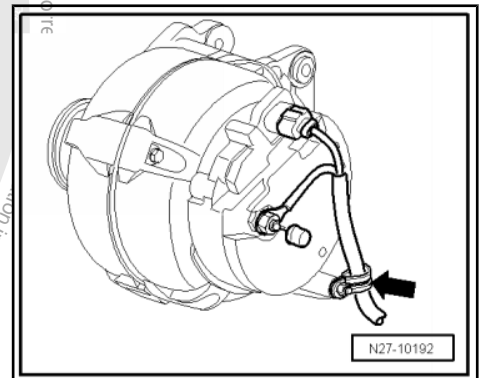



Caution

*Observe instructions on connecting battery terminals
 => [page 4](#) .*

- Connect the battery => [page 29](#) .
- Start the engine and check belt running.
- Switch off the engine.

9.4.3 Ribbed belt routing, 1.6 l injection engine

Models with air conditioning system:

- 1 - Tensioning roller
- 2 - Ribbed belt pulley - Alternator
- 3 - Ribbed belt pulley - Air conditioner compressor
- 4 - Poly V-belt
- 5 - Ribbed belt pulley - Crankshaft

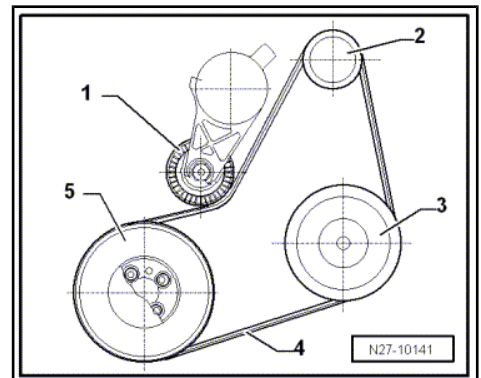



9.5 Alternator, 1.6 I FSI engine

9.5.1 Assembly overview

- 1 - Hexagon bolt
 - 40 Nm
- 2 - Washer
- 3 - Idler roller
- 4 - Washer
- 5 - Valve gear casing
- 6 - Hexagon head collared nut
 - M8
- 7 - Cross-head screw
 - M5x21
 - 4.5 Nm
- 8 - Hexagon nut, flat
 - M8
- 9 - Plain washer
 - M5
- 10 - Protective cap
- 11 - Phillips screws
 - M4x19
 - 2 Nm
- 12 - Cross-head screw
 - M4x13
 - 2 Nm
- 13 - Voltage regulator
 - Removing and installing voltage regulator
⇒ [page 142](#)
- 14 - Alternator
 - Removing and installing alternator ⇒ [page 105](#)
- 15 - Poly V-belt
 - Checking ribbed belt (poly V-belt) ⇒ [page 98](#)
- 16 - Hexagon head collared bolts
 - M8x90
 - 23 Nm
- 17 - Hexagon head collared bolts
 - M8x50
 - 25 Nm
- 18 - Tensioning element
- 19 - Bracket
 - For tensioning element and air conditioner compressor
- 20 - Hexagon head collared bolt
 - M10x50

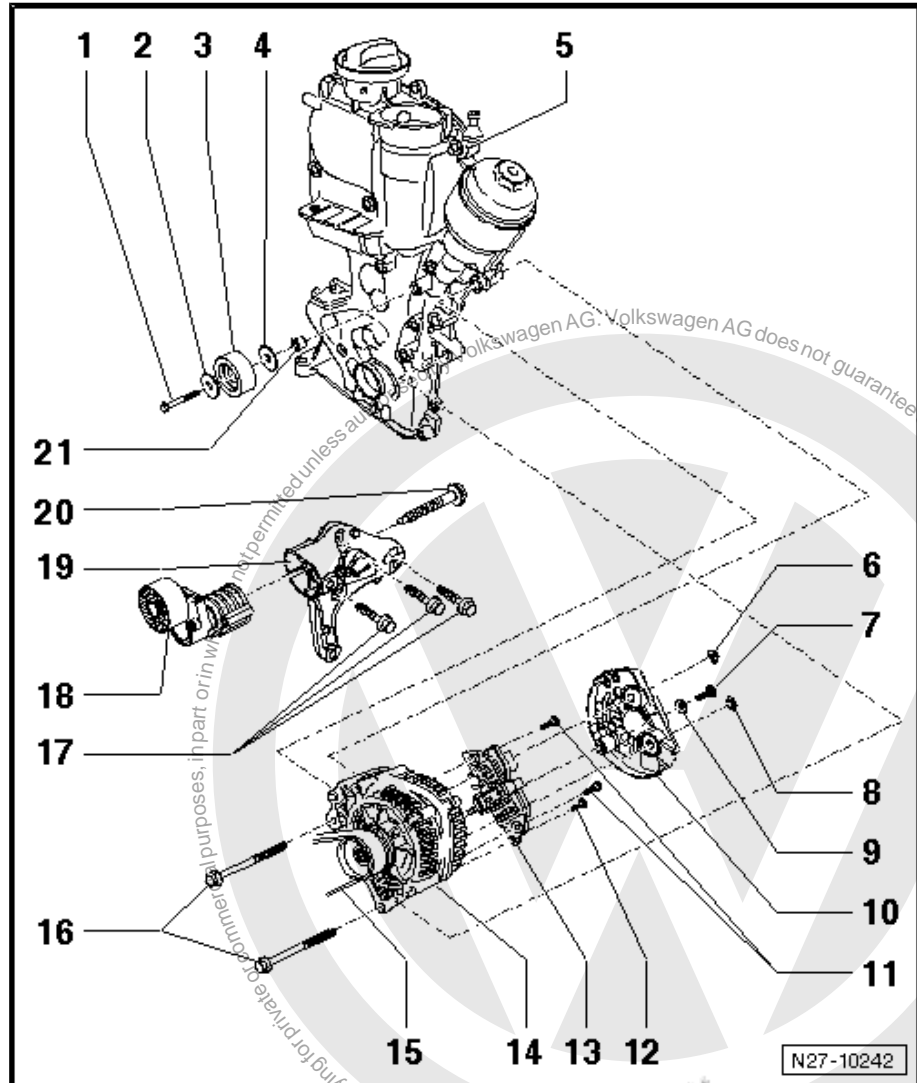



- 20 Nm + 1/4 turn (90°) further

21 - Spacer sleeve

9.5.2 Removing and installing alternator, 1.6 l FSI engine

Special tools and workshop equipment required

- ◆ Torque wrench -V.A.G 1331-

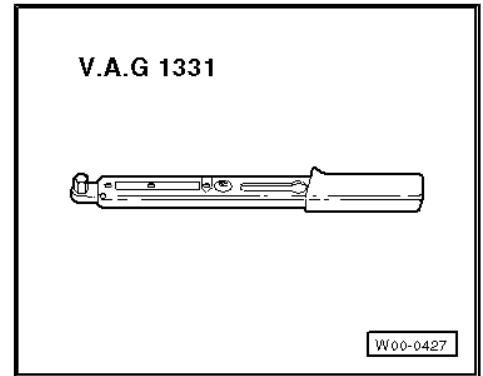

- ◆ Locking pin -T10060 A-

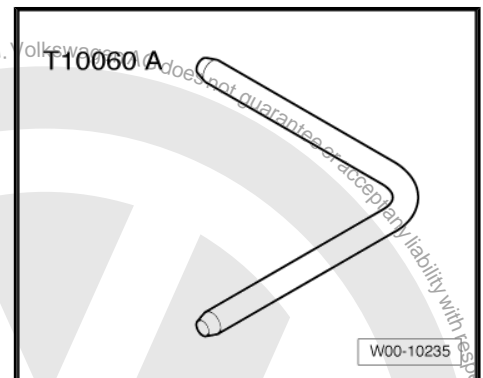

Removing:

- Disconnect the battery ⇒ [page 29](#) .
- Remove upper securing bolt of alternator -arrow-.
- Remove noise insulation ⇒ General Body Repairs, Exterior; Rep. Gr. 50 ; Noise insulation .

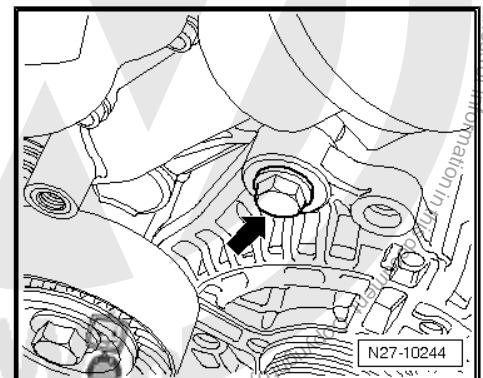



- Remove wiring bracket -1- and pull protective cap -2- off.

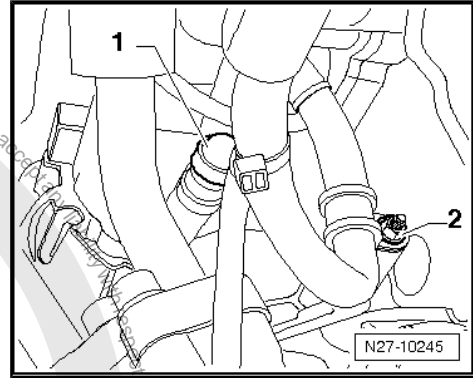

- Disconnect connector of DF wiring -1- and pull B+ wiring -2- off alternator.

Caution

Mark top and direction of rotation of poly V-belt before removing. When installing observe direction of rotation marked on removal. Installing opposite to the direction of rotation leads to belt damage!

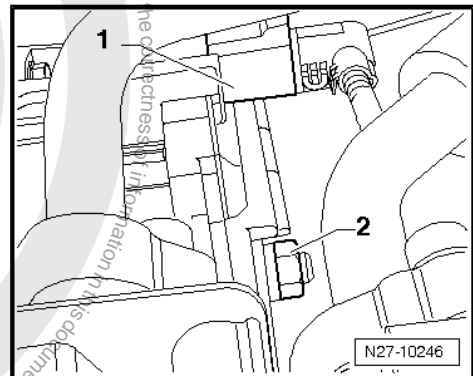

- Mark direction of rotation of poly V-belt.
- Release poly V-belt by turning the tensioning device with an open-ended spanner AF 16 in -direction of arrow-.
- Lock tensioning element with retaining pin -T10060 A-.
- Remove ribbed belt.
- Remove air conditioner compressor => Heating, air conditioner; Rep. Gr. 87 ; Repair work on refrigerant circuit must be carried out in workshops with trained personnel only (workshop service centres for air conditioning system); Removing and installing compressor

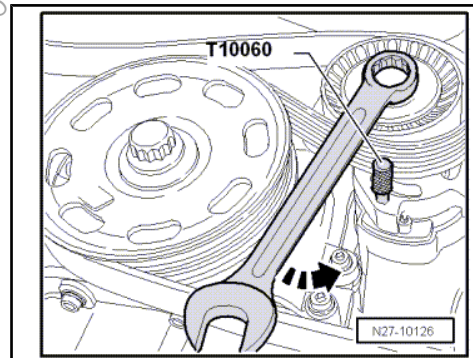

- Remove lower securing bolt of alternator -arrow-.
- Remove alternator from vehicle downwards.

Installing:

Installation is carried out in the reverse order. When installing, note the following:

Caution

- ◆ *When reinstalling used ribbed belts (poly V-belts) observe the direction of rotation marked on removal!*
- ◆ *Ensure, before installing poly V-belt, that all ancillaries (alternator, air conditioner compressor, power assisted steering vane pump) are secured tightly.*
- ◆ *Ensure ribbed belt (poly V-belt) is seated correctly in belt pulley when installing.*

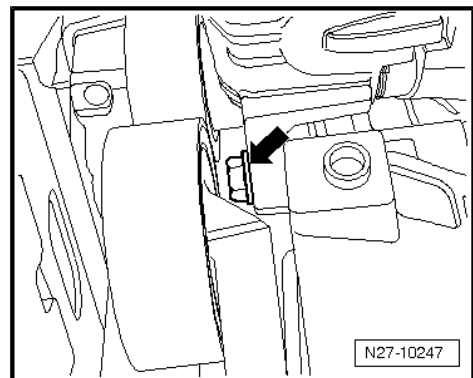



- Drive threaded sleeves -A- out of the alternator housing for approx. 4 mm in -direction of arrow-.

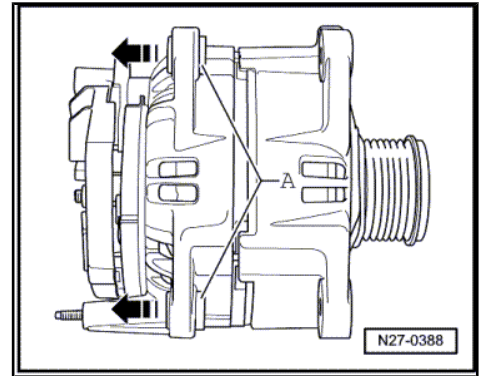

- Position wiring bracket -arrow- on rear of generator at 9 o'clock.
- Tighten threaded connections to specified torque settings => [page 145](#) .
- Start the engine and check belt running.

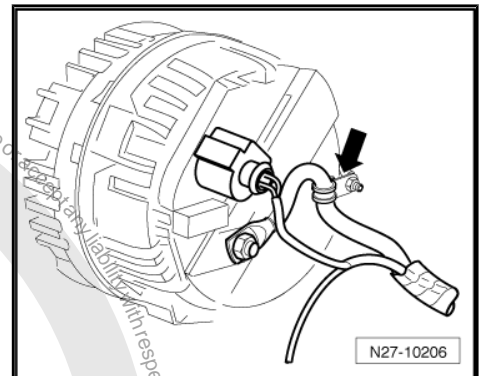

9.5.3 Ribbed belt routing, 1.6 I FSI engine

Models without air conditioning system:

- 1- Ribbed belt (poly V-belt) pulley – Coolant pump
- 2- Tensioning roller
- 3- Ribbed belt (poly V-belt) pulley – Alternator
- 4- Poly V-belt
- 5- Ribbed belt (poly V-belt) pulley - Crankshaft

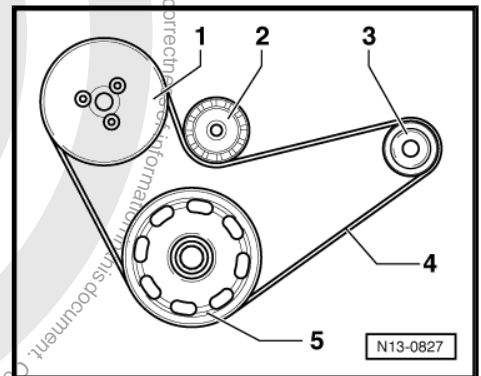

Models with air conditioning system:

- 1- Ribbed belt (poly V-belt) pulley – Coolant pump
- 2- Idler roller
- 3- Ribbed belt (poly V-belt) pulley – Alternator
- 4- Tensioning roller
- 5- Ribbed belt (poly V-belt) pulley – Air conditioner compressor
- 6- Poly V-belt
- 7- Ribbed belt (poly V-belt) pulley - Crankshaft

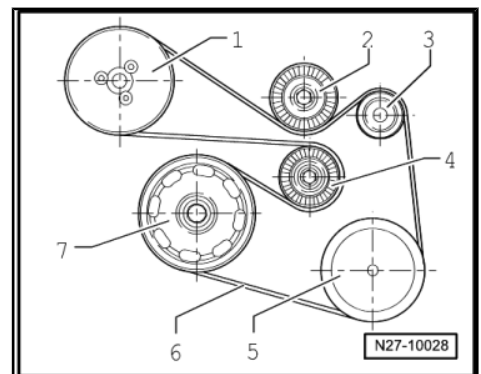



9.6 Alternator, 2.0 I FSI engine

9.6.1 Assembly overview

1 - Hexagon head collared bolts

- M8x90
- 23 Nm

2 - Hexagon head collared bolts

- M8x50
- 23 Nm

3 - Transport bracket

4 - Tensioning element for poly V-belt

5 - Compact bracket

- For alternator and air conditioner compressor
- Tightening sequence
⇒ [page 146](#)

6 - Hexagon head collared bolts

- M10x45
- 52 Nm

7 - Protective cap

8 - Hexagon head collared nut

- M8

9 - Cross-head screw

- M5x21
- 4.5 Nm

10 - Hexagon nut, flat

- M8

11 - Plain washer

- M5

12 - Phillips screws

- M4x19
- 2 Nm

13 - Cross-head screw

- M4x13
- 2 Nm

14 - Voltage regulator

- Removing and installing voltage regulator ⇒ [page 142](#)

15 - Alternator

- Removing and installing alternator ⇒ [page 109](#)

16 - Poly V-belt

- Checking ⇒ [page 98](#) .

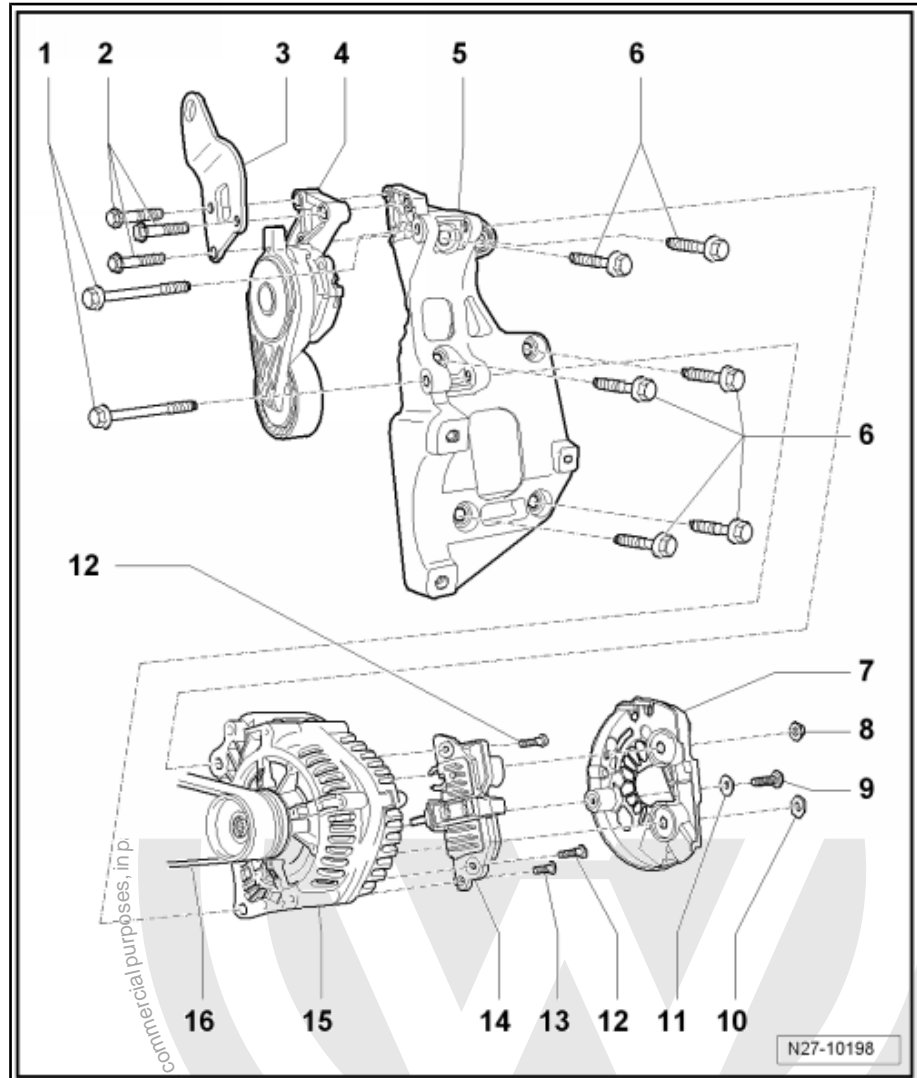



9.6.2 Removing and installing alternator, 2,0 I FSI engine



Caution

Disconnecting and connecting the battery as described in the Workshop Manual ⇒ [page 29](#).

Special tools and workshop equipment required

- ◆ Torque wrench -V.A.G 1331-
- ◆ Locking pin -T10060- or locking pin -T10060 A-
- ◆ Spring-type clip pliers -VAS 5024 A-

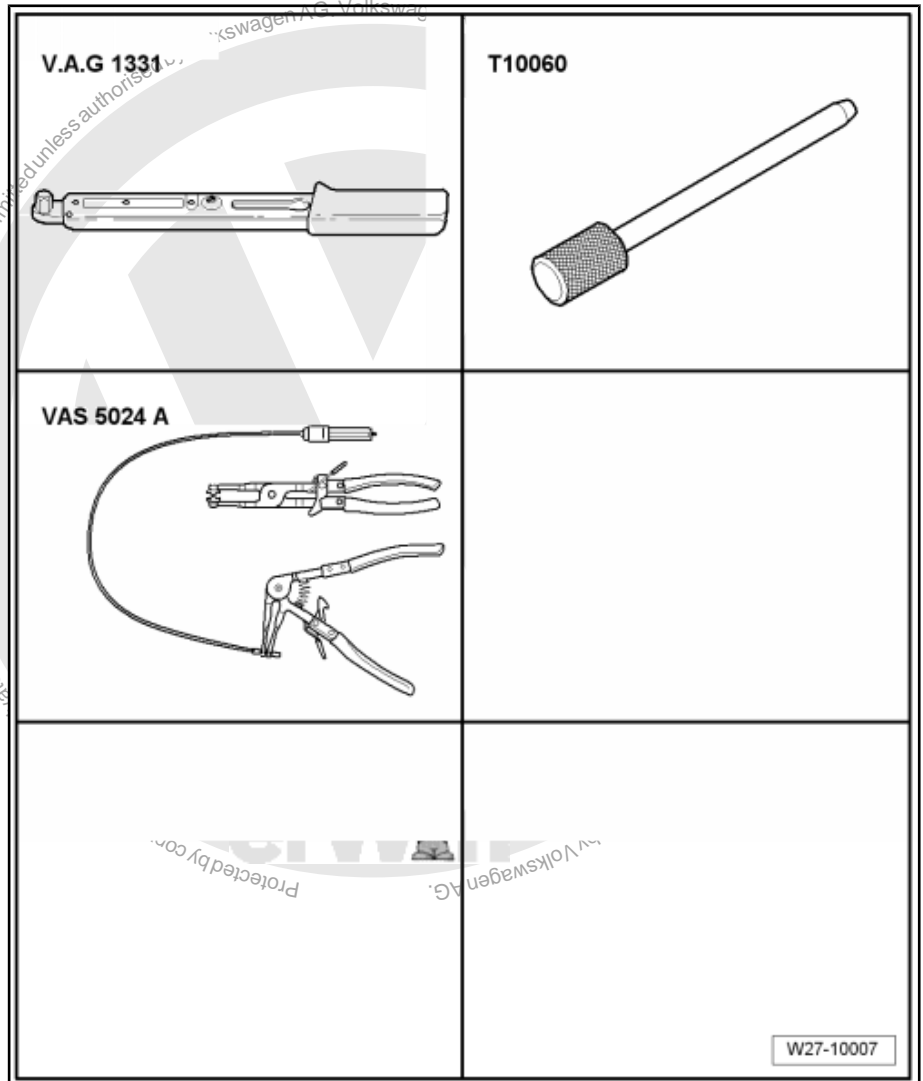

Removing:

- Disconnect the battery ⇒ [page 29](#) .



- Pull engine cover off upwards -arrows-.

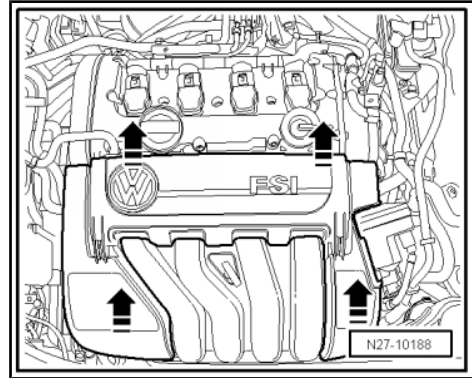

- Disconnect connector -arrow-.

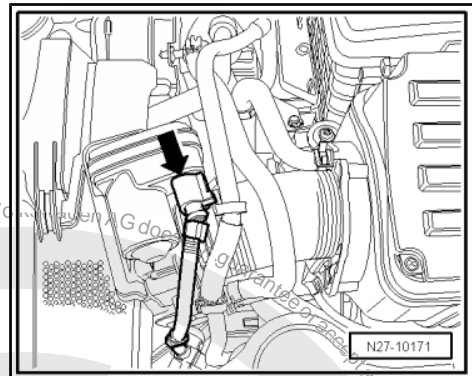

- Unclip vacuum hose from its mounting -arrow-.

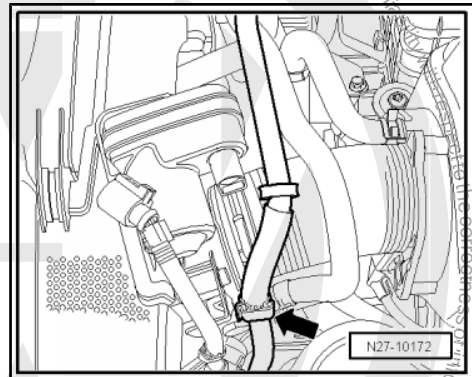

- Loosen spring-type clip -arrow- from hose -1- using spring type clip pliers -VAS 5024 A- .
- Pull hose -1- off air filter housing.

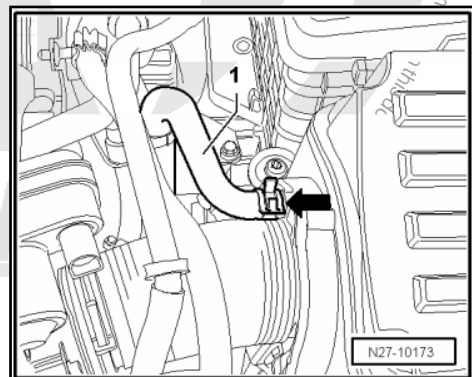



- Open retainer -arrow- on front side of air filter housing and take hose -1- off.

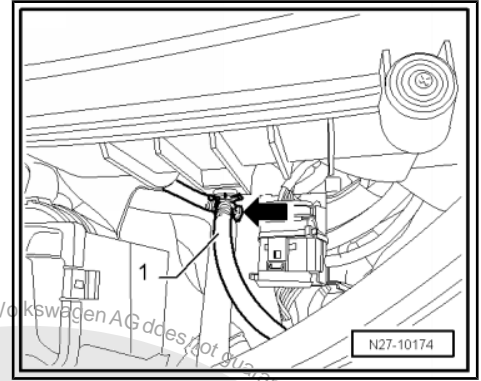

- Unscrew air filter housing securing bolt -arrow-.

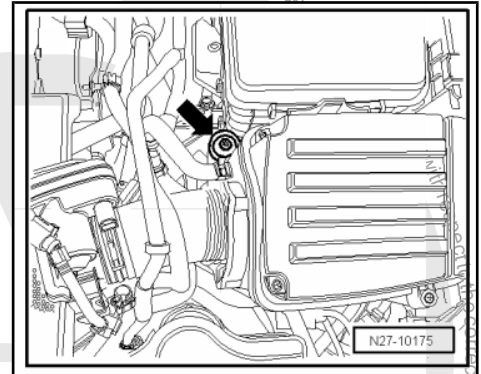

- Pull air filter housing on right side upwards off rubber mounting -arrow-.

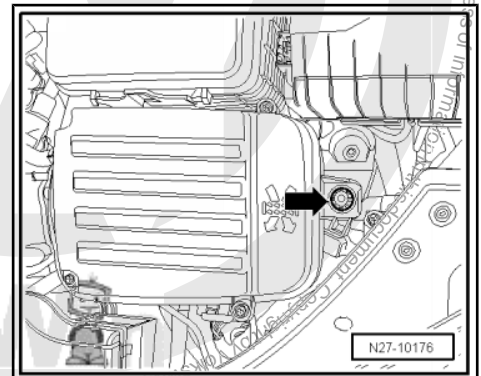

- Loosen spring-type clip -1- using spring type clip pliers -VAS 5024 A- .
- Pull hose -2- off pipe union.
- Carefully lift air filter housing upwards out of the vehicle taking into consideration the length of the hose.

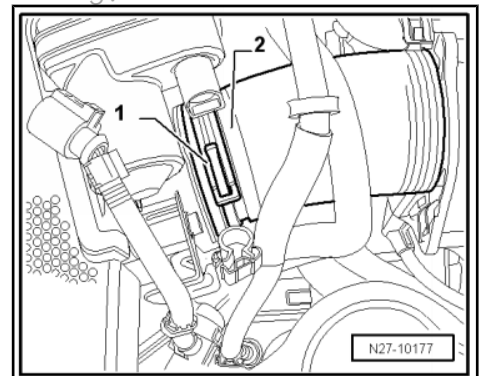



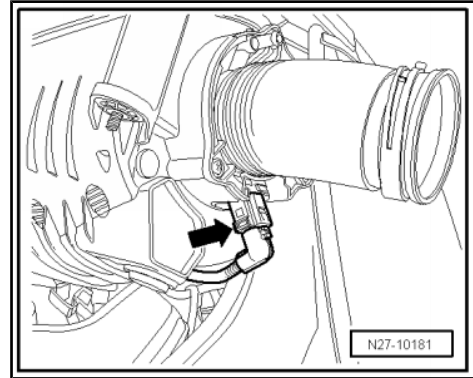

- Separate connector -arrow- on rear of air filter housing.
- Remove air filter housing from vehicle.
- Remove upper intake manifold.

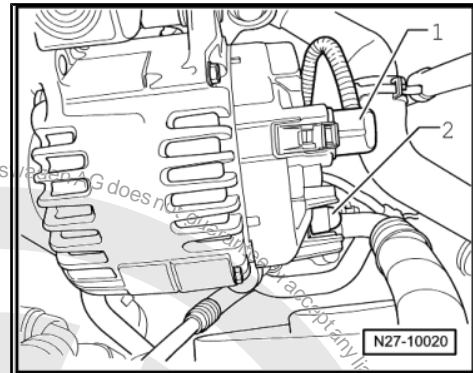

- Disconnect connector of DF wiring -1- and pull protective cap -2- off.



- Unscrew B+ wiring -arrow- off alternator.

 **Caution**
Mark top and direction of rotation of poly V-belt before removing. When installing observe direction of rotation marked on removal. Installing opposite to the direction of rotation leads to belt damage!

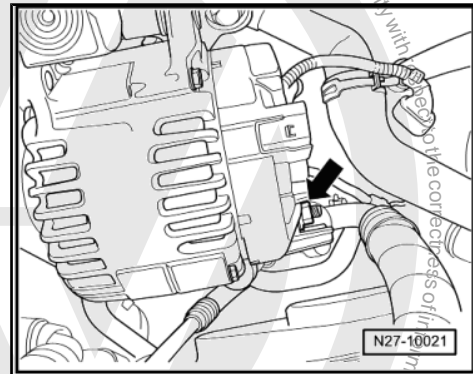

- Mark direction of rotation of poly V-belt.
- Release poly V-belt by turning the tensioning device with an open-ended spanner AF 16 in -direction of arrow-.

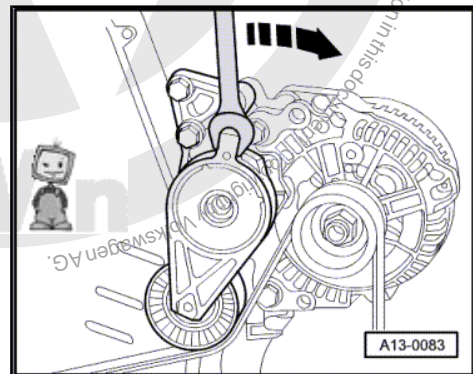



- Lock tensioning element with retaining pin -T10060 A- .
- Remove ribbed belt.

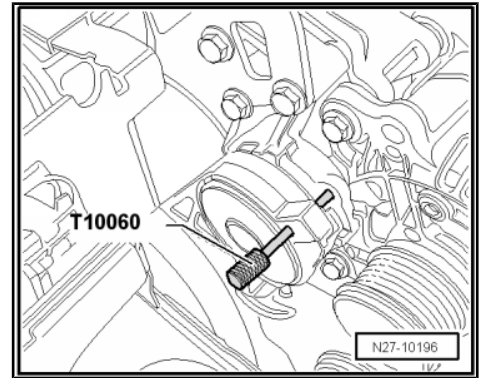

- Remove securing bolts of tensioning element -arrows-.
- Take tensioning element together with lifting eye -1- out of the vehicle.

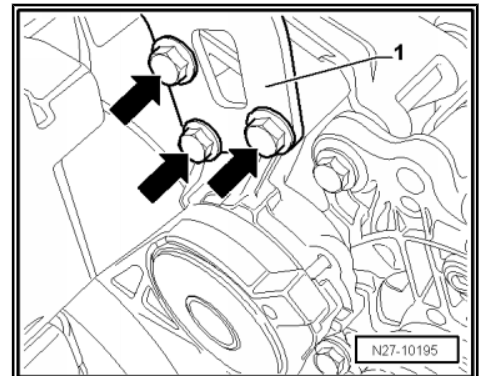

- Remove alternator securing bolts -arrows-.

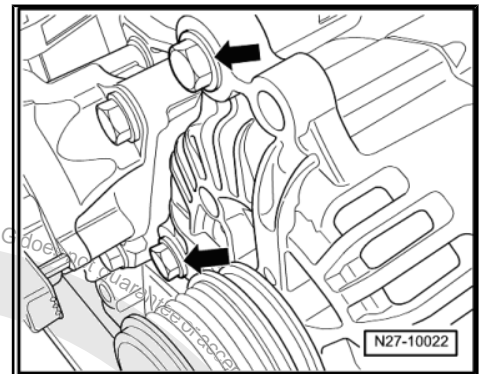

- Unscrew wiring bracket -arrow- from alternator.
- Take alternator out of the vehicle.

Installing:

Installation is carried out in the reverse order. When installing, note the following:

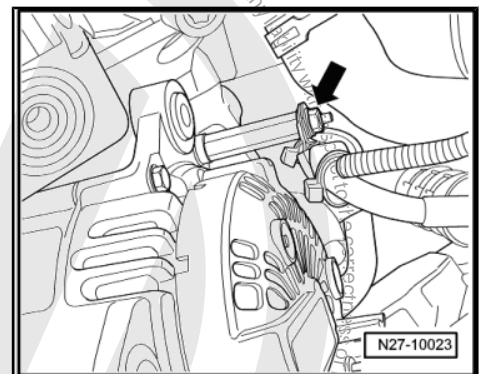

Protected by copyright. Copying for private or commercial purposes, in part or in whole, is not permitted unless authorised by Volkswagen AG. Volkswagen AG. Information in this document. Copyright by Volkswagen AG.





- Drive threaded sleeves -A- out of the alternator housing for approx. 4 mm in -direction of arrow-.

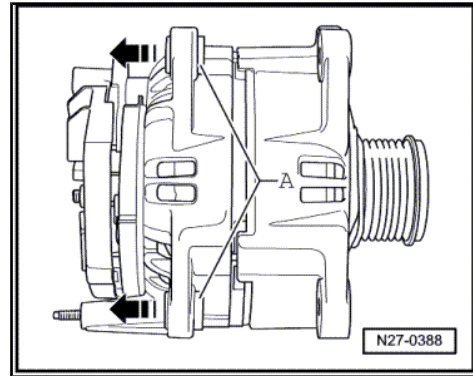

- Position wiring bracket -arrow- on rear of generator at 12 o'clock.
- Tighten threaded connections to specified torque settings => [page 145](#) .

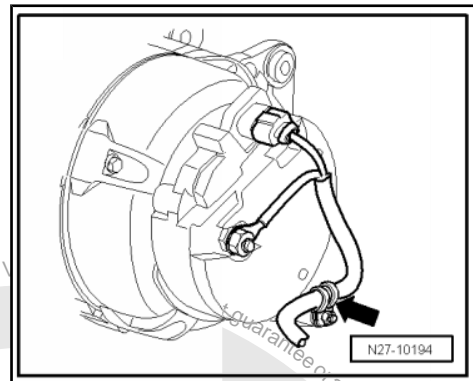

Caution

- ◆ *When reinstalling used ribbed belts (poly V-belts) observe the direction of rotation marked on removal!*
- ◆ *Ensure, before installing ribbed belt, that all ancillaries (alternator, air conditioner compressor) are secured tightly.*
- ◆ *Ensure ribbed belt (poly V-belt) is seated correctly in belt pulley when installing.*

- Tighten threaded connections to specified torque settings => [page 145](#) .



Caution

Observe instructions on connecting battery terminals => [page 4](#) .

- Connect the battery => [page 29](#)
- Start the engine and check belt running.
- Switch off the engine.

9.6.3 Ribbed belt routing, 2.0 I FSI engine

Models without air conditioning system:

- 1 - Tensioning roller
- 2 - Ribbed belt pulley - Alternator
- 3 - Poly V-belt
- 4 - Ribbed belt pulley - Crankshaft

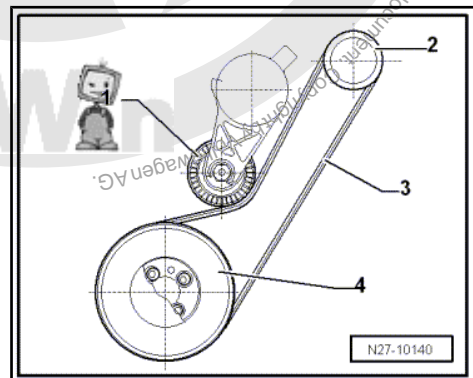



Models with air conditioning system:

- 1 - Tensioning roller
- 2 - Ribbed belt pulley - Alternator
- 3 - Ribbed belt pulley - Air conditioner compressor
- 4 - Poly V-belt
- 5 - Ribbed belt pulley - Crankshaft

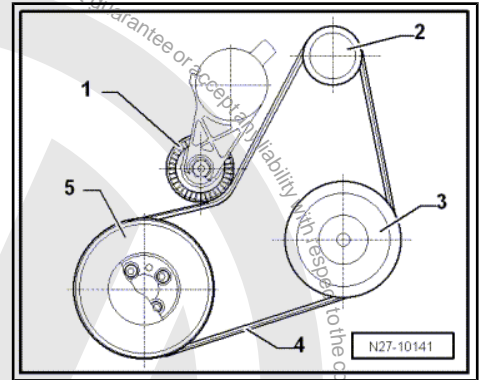

9.7 Alternator, 2.0 I FSI turbo engine

9.7.1 Assembly overview

- 1 - Hexagon head collared bolts**
 - M8x45
 - 23 Nm
- 2 - Hexagon head collared bolts**
 - M8x90
 - 23 Nm
- 3 - Compact bracket**
 - For alternator and air conditioner compressor
 - Tightening sequence
 ⇒ [page 146](#)
- 4 - Hexagon head collared bolts**
 - M10x45
 - 45 Nm
- 5 - Protective cap**
- 6 - Hexagon head collared nut**
 - M8
- 7 - Cross-head screw**
 - M5x21
 - 4.5 Nm
- 8 - Hexagon nut, flat**
 - M8
- 9 - Plain washer**
 - M5
- 10 - Phillips screws**
 - M4x19
 - 2 Nm
- 11 - Cross-head screw**
 - M4x13
 - 2 Nm

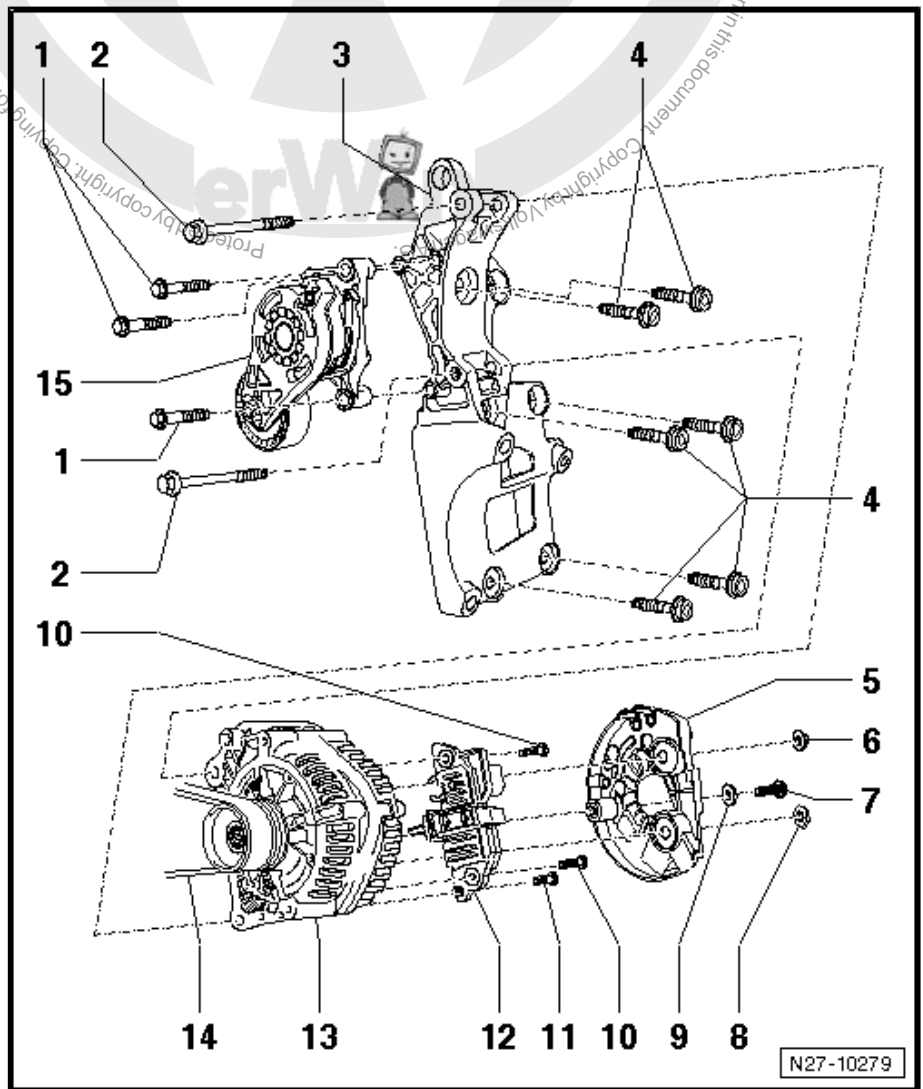



12 - Voltage regulator

- ❑ Removing and installing voltage regulator ⇒ [page 142](#)

13 - Alternator

- ❑ Removing and installing alternator ⇒ [page 116](#)

14 - Poly V-belt

- ❑ Checking ⇒ [page 98](#) .

15 - Tensioning element for poly V-belt

9.7.2 Removing and installing alternator, 2.0 I turbo FSI engine



Caution

Disconnecting and connecting the battery as described in the Workshop Manual ⇒ [page 29](#) .

Special tools and workshop equipment required

- ◆ Torque wrench -V.A.G 1331-
- ◆ Locking pin -T10060- or locking pin -T10060 A-
- ◆ Spring-type clip pliers -VAS 5024 A-

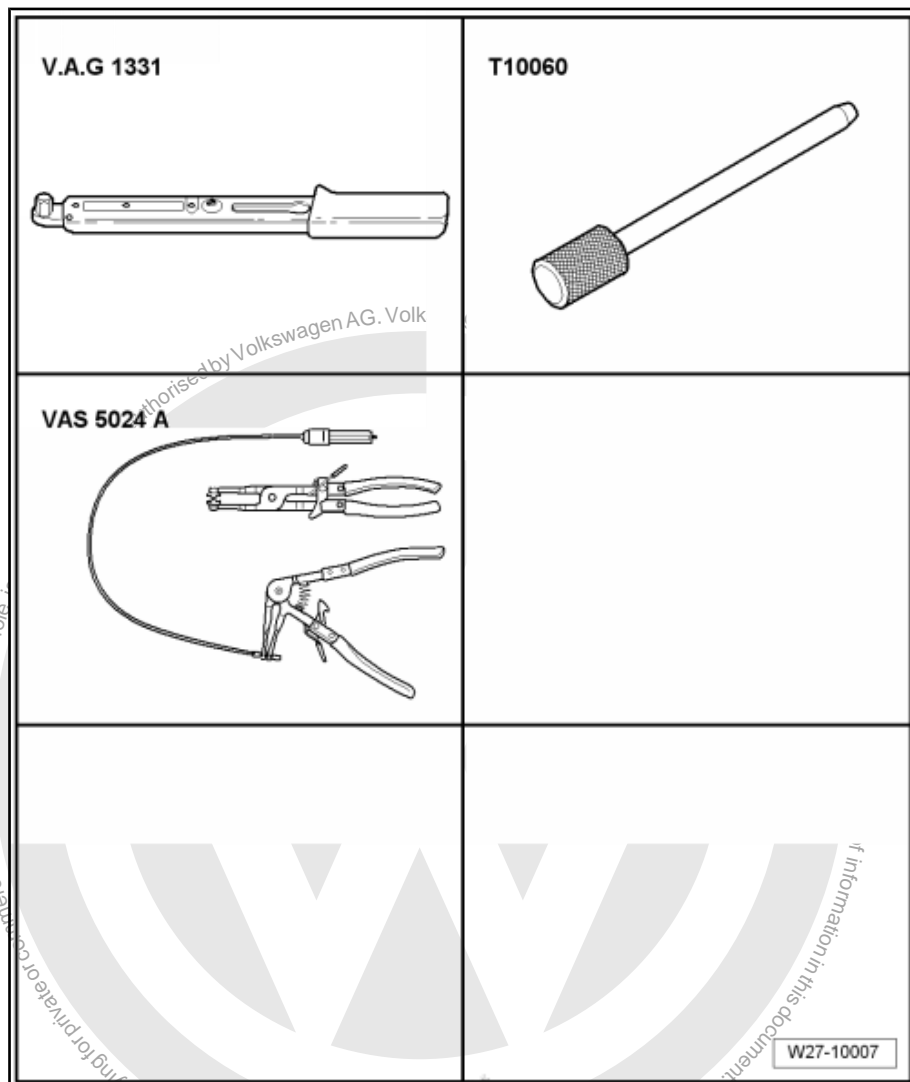



Removing:

- Disconnect the battery ⇒ [page 29](#) .
- Unbolt securing bolts -arrow-.

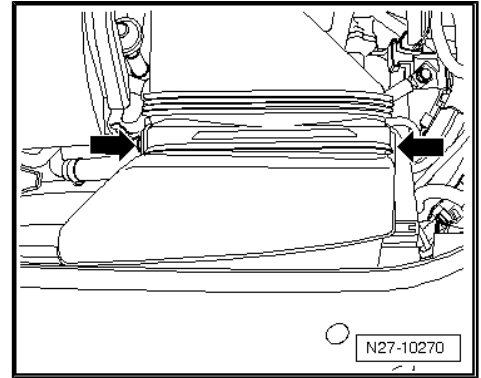

- Disconnect connector -arrow-.

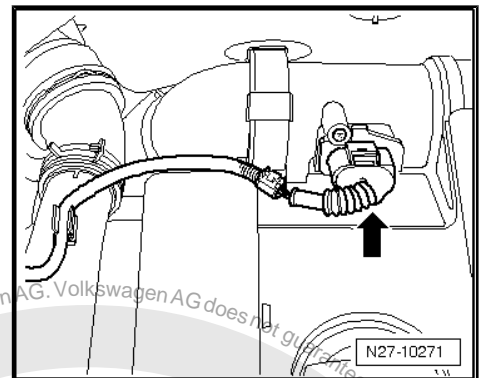

- Loosen spring-type clips -1- using spring type clip pliers -VAS 5024 A- .

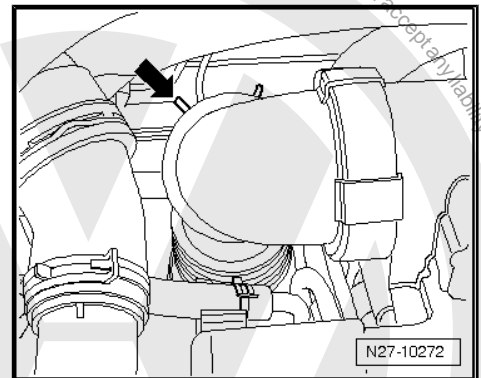

- Pull engine cover off upwards -arrows-.

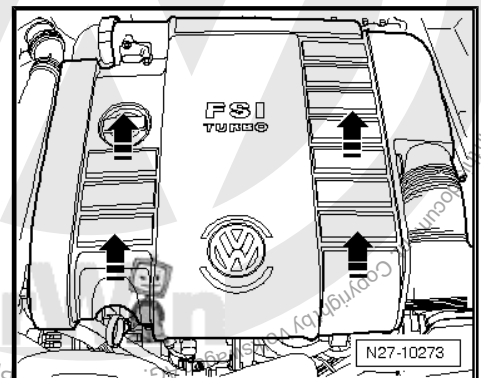



Note

- ◆ All hoses of the charge air system are secured with hose clips or with quick release couplings. When using quick release couplings the following points must be observed:
- ◆ Unlock connection by pulling the securing clamp -arrow-.
- ◆ Pull hose/tube off without assistance of tools.

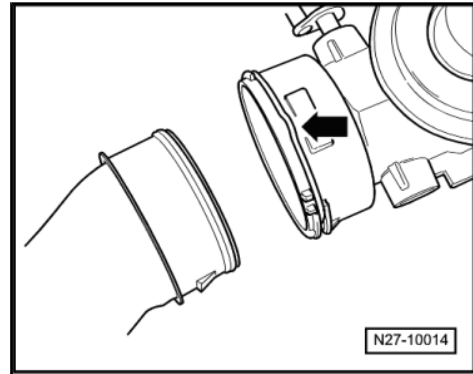

- Disconnect quick release coupling -arrow-.

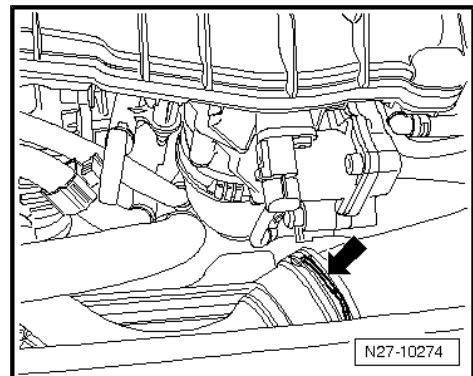

- Loosen spring-type clip -arrow- using spring type clip pliers -VAS 5024 A- .

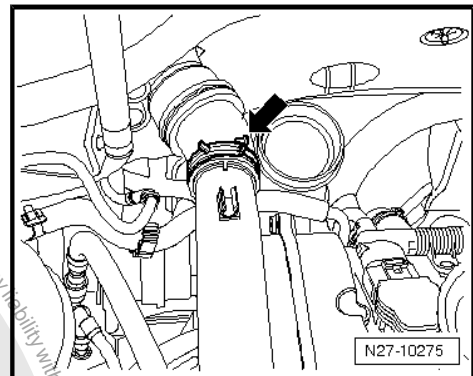

- Unbolt securing bolts -arrow-.

Take hose out of the vehicle.

Remove connecting pipe between charge air cooler and turbocharger.

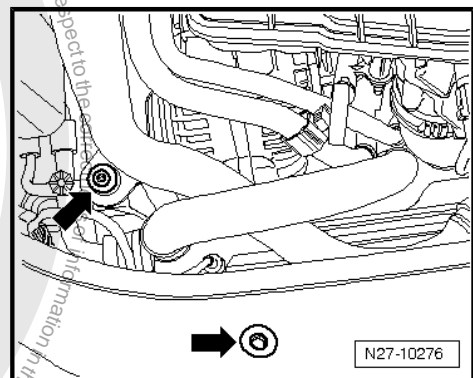

Caution

Mark top and direction of rotation of poly V-belt before removing. When installing observe direction of rotation marked on removal. Installing opposite to the direction of rotation leads to belt damage!

- Mark direction of rotation of poly V-belt.



- Release poly V-belt by turning the tensioning element with an open jaw spanner AF 16 in -direction of arrow- and lock tensioning element with retaining pin -T10060 A- .
- Remove ribbed belt.

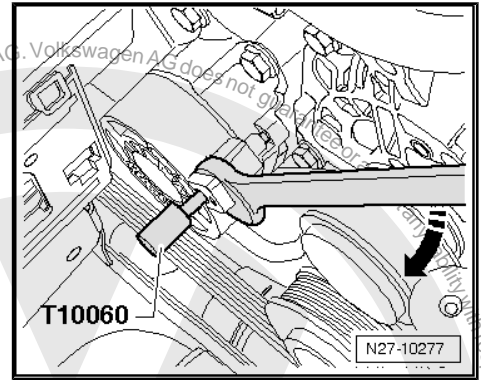

- Loosen threaded connections of coolant pipe -arrows-.



Note

The coolant pipe can remain installed. To take out the alternator it must be loosened.

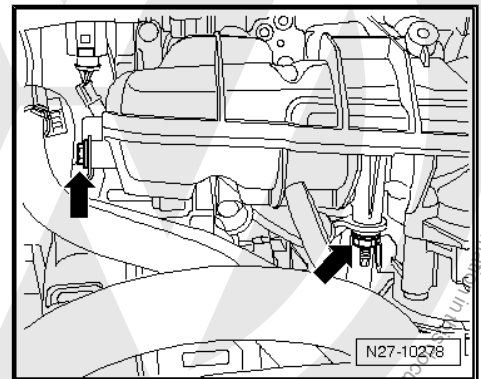

- Remove alternator securing bolts -arrows-.

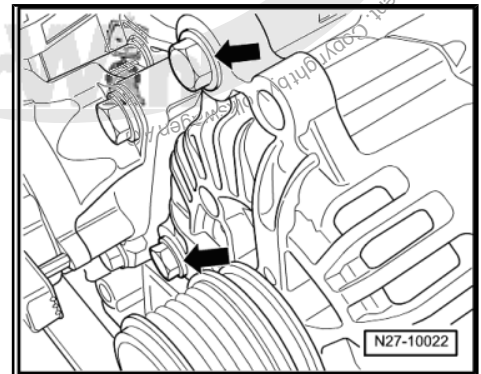

- Disconnect connector of DF wiring -1- and pull protective cap -2- off.

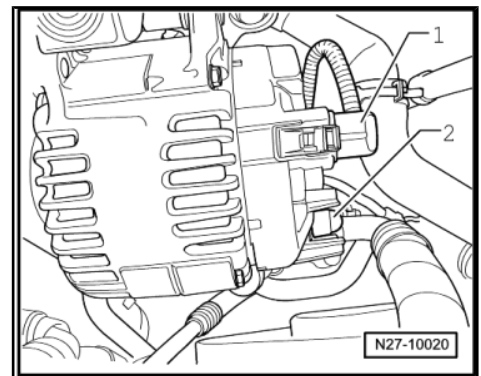



- Unscrew B+ wiring -arrow- off alternator.

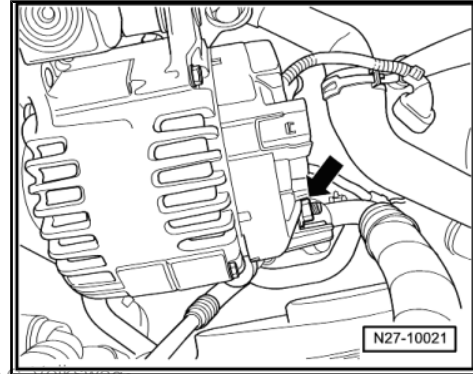

- Unscrew wiring bracket -arrow- from alternator.
- Take alternator out of the vehicle.

Installing:

Installation is carried out in the reverse order. When installing, note the following:



Caution

- ◆ *When reinstalling used ribbed belts (poly V-belts) observe the direction of rotation marked on removal!*
- ◆ *Ensure, before installing ribbed belt, that all ancillaries (alternator, air conditioner compressor) are secured tightly.*
- ◆ *Ensure ribbed belt (poly V-belt) is seated correctly in belt pulley when installing.*

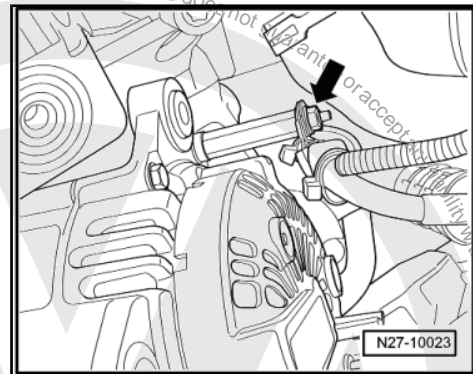

- Drive threaded sleeves -A- out of the alternator housing for approx. 4 mm in -direction of arrow-.

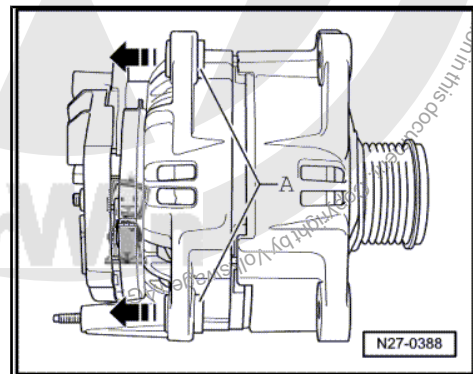

- Position wiring bracket -arrow- on rear of generator at 9 o'clock.

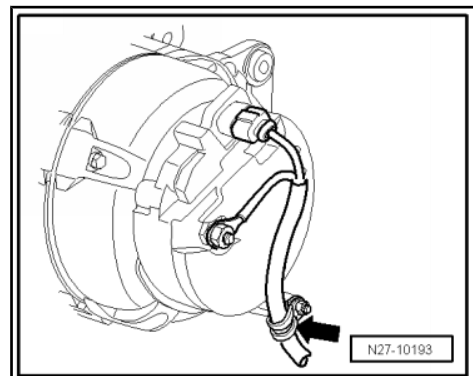



Note

- ◆ All hoses of the charge air system are secured with hose clips or with quick release couplings. When using quick release couplings the following points must be observed:
 - ◆ Fit hose/tube without assistance of tools.
 - ◆ Check for secure fit of the lugs -arrow-.
- Tighten threaded connections to specified torque settings
 ⇒ [page 145](#) .



Caution

**Observe instructions on connecting battery terminals
 ⇒ [page 4](#) .**

- Connect the battery ⇒ [page 29](#) .
- Start the engine and check belt running.
- Switch off the engine.

9.7.3 Ribbed belt routing 2.0 I turbo engine

Models without air conditioning system:

- 1 - Tensioning roller
- 2 - Ribbed belt pulley - Alternator
- 3 - Poly V-belt
- 4 - Ribbed belt pulley - Crankshaft

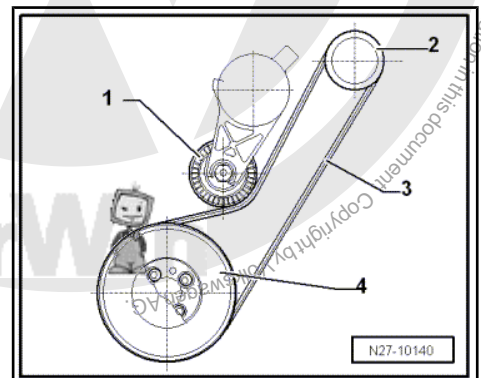

Models with air conditioning system:

- 1 - Tensioning roller
- 2 - Ribbed belt pulley - Alternator
- 3 - Ribbed belt pulley - Air conditioner compressor
- 4 - Poly V-belt
- 5 - Ribbed belt pulley - Crankshaft

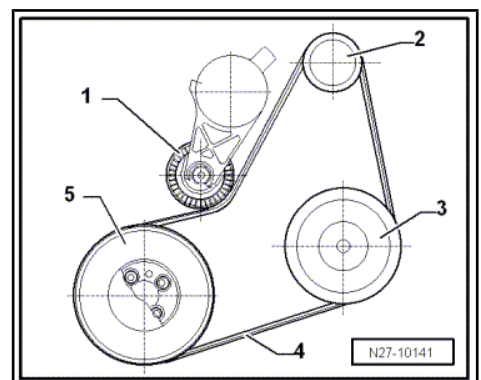



9.8 Alternator 2.5 l injection engine

9.8.1 Assembly overview

1 - Compact bracket

- For alternator and air conditioner compressor

2 - Multi-point socket head bolt M8x60

- 25 Nm

3 - Multi-point socket head bolt M8x110

- 25 Nm

4 - Hexagon socket head bolt M8x30

- 25 Nm
- Qty. 4

5 - Protective cap for alternator

6 - Phillips screws

- M4x20
- 2 Nm

7 - Protective cap for carbon brushes

8 - Voltage regulator

- Removing and installing voltage regulator
⇒ [page 142](#)

9 - Alternator

- Removing and installing alternator ⇒ [page 127](#)

10 - Poly V-belt

- Checking ⇒ [page 98](#) .

11 - Hexagon head collared bolts M8x90

- 25 Nm
- Qty. 2

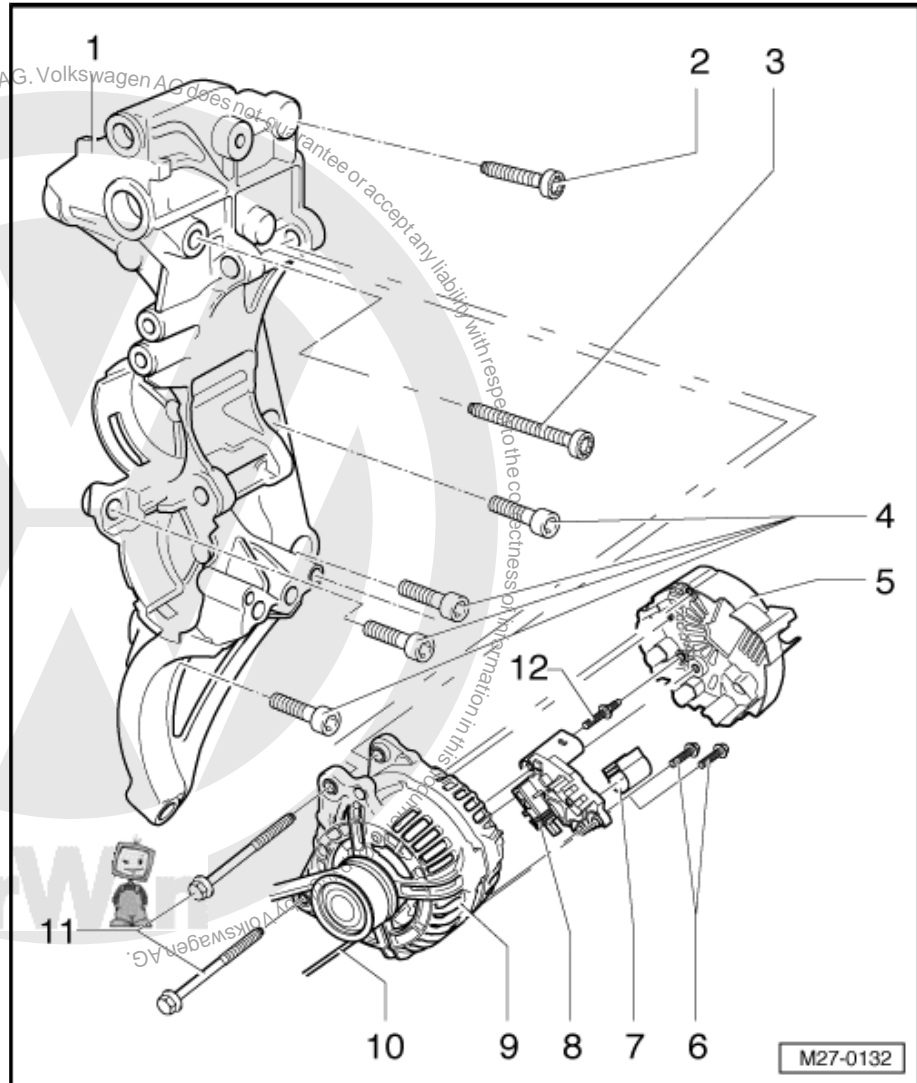

9.8.2 Removing and installing alternator, 2.5l engine



Caution

Disconnecting and connecting the battery as described in the Workshop Manual ⇒ [page 29](#) .

Removing:

Special tools and workshop equipment required



- ◆ Torque wrench -V.A.G 1331-

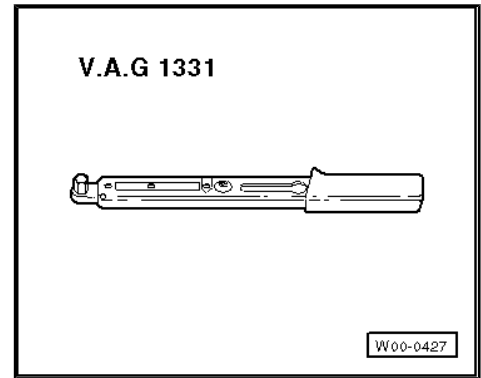

- ◆ Locking pin -T10060 A-

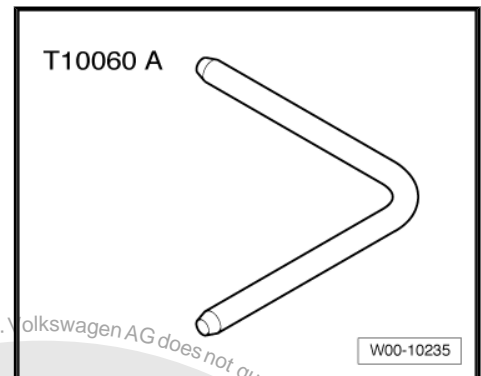

- Disconnect the battery ⇒ [page 29](#) .
- Take the engine cover off upwards and forwards.
- Bring lock carrier into service position ⇒ General body repairs, exterior; Rep. Gr. 50 ; Lock carrier service position
- Take off poly V-belt ⇒ Rep. Gr. 13

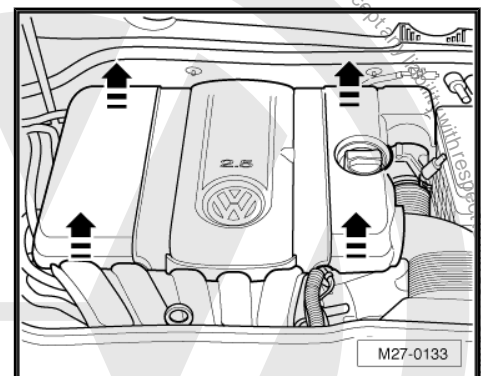

- Disconnect connector of DF wiring -1- and pull protective cap -2- off.

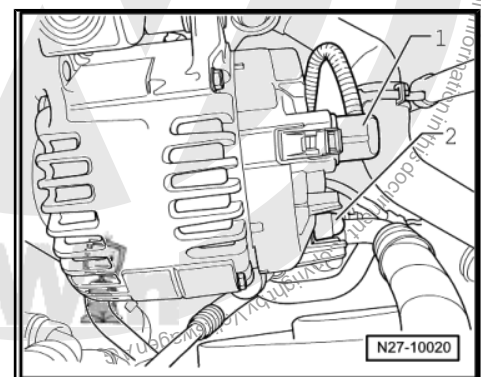



- Unscrew B+ wiring -arrow- off alternator.



Caution

Mark top and direction of rotation of poly V-belt before removing. When installing observe direction of rotation marked on removal. Installing opposite to the direction of rotation leads to belt damage!

- Remove upper and lower idler roller and tensioning roller for alternator poly V-belt, and coolant pump ⇒ Rep. Gr. 13
- Remove alternator securing bolts -arrows-.

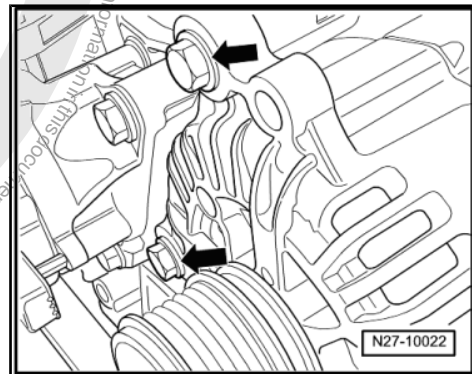
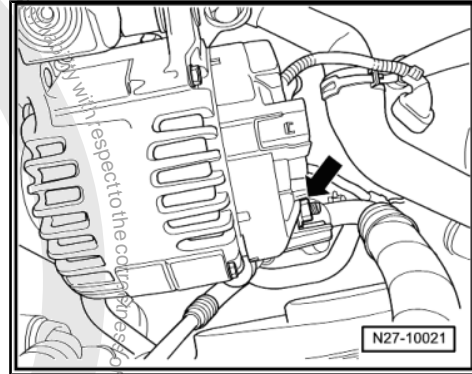

- Unscrew wiring bracket from alternator -arrow-.
- Take alternator out upwards.

Installing:

Installation is carried out in the reverse order. When installing, note the following:



Caution

- ◆ **When reinstalling used ribbed belts (poly V-belts) observe the direction of rotation marked on removal!**
- ◆ **Ensure, before installing ribbed belt, that all ancillaries (alternator, air conditioner compressor) are secured tightly.**
- ◆ **Ensure ribbed belt (poly V-belt) is seated correctly in belt pulley when installing.**

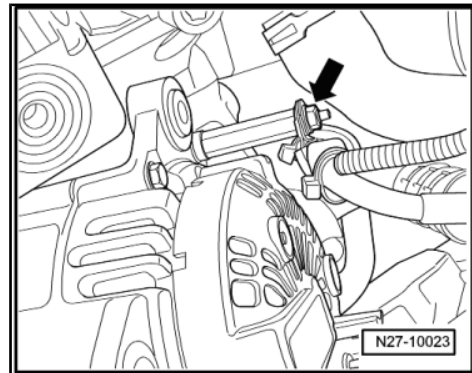

- Drive threaded sleeves -A- out of the alternator housing for approx. 4 mm in direction of arrow.

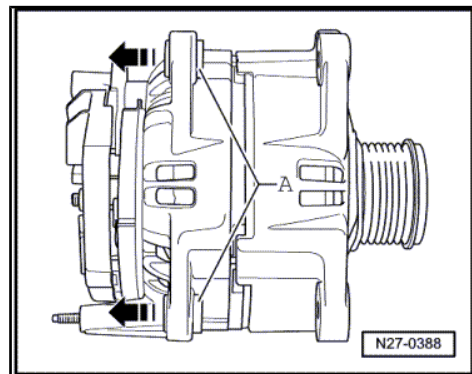



- Position wiring bracket -arrow- on rear of generator at 9 o'clock.
- Tighten threaded connections to specified torque settings
=> [page 145](#) .

 **Caution**
Observe instructions on connecting battery terminals
=> [page 4](#) .

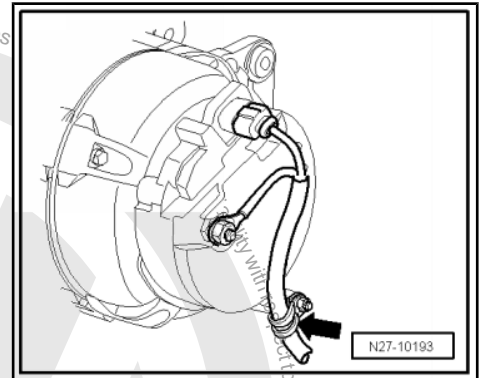

- Connect the battery => [page 29](#) .
- Start the engine and check belt running.
- Switch off the engine.

9.8.3 Ribbed belt routing, 2.5l engine

Models with air conditioning system:

- 1 - Upper idler roller
- 2 - Belt pulley - Alternator
- 3 - Lower idler roller
- 4 - Poly V-belt for alternator and coolant pump
- 5 - Belt pulley - Air conditioner compressor
- 6 - Poly V-belt for air conditioner compressor
- 7 - Belt pulley - Crankshaft
- 8 - Tensioning roller for air conditioner compressor poly V-belt
- 9 - Tensioning roller for alternator poly V-belt and coolant pump
- 10 - Belt pulley - Coolant pump

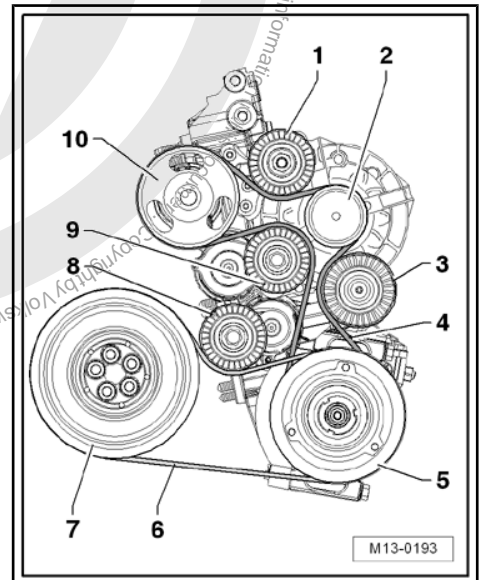



9.9 Alternator, 1.9 I TDI engine

9.9.1 Assembly overview

1 - Hexagon head collared bolts

- M8x45
- 20 Nm

2 - Tensioning element for poly V-belt

3 - Hexagon head collared bolts

- M8x90
- 20 Nm

4 - Compact bracket

- For alternator and air conditioner compressor
- Tightening sequence
⇒ [page 148](#)

5 - Hexagon head collared bolts

- M10x65
- 40 Nm

6 - Hexagon head collared bolts

- M10x45
- 40 Nm

7 - Hexagon bolt with washer and threaded piece

- M4x20, M4x15
- 2 Nm

8 - Protective cap for alternator

9 - Phillips screws

- M4x20
- 2 Nm

10 - Protective cap for carbon brushes

11 - Voltage regulator

- Removing and installing voltage regulator ⇒ [page 142](#)

12 - Alternator

- Removing and installing alternator ⇒ [page 127](#)

13 - Poly V-belt

- Checking ⇒ [page 98](#) .

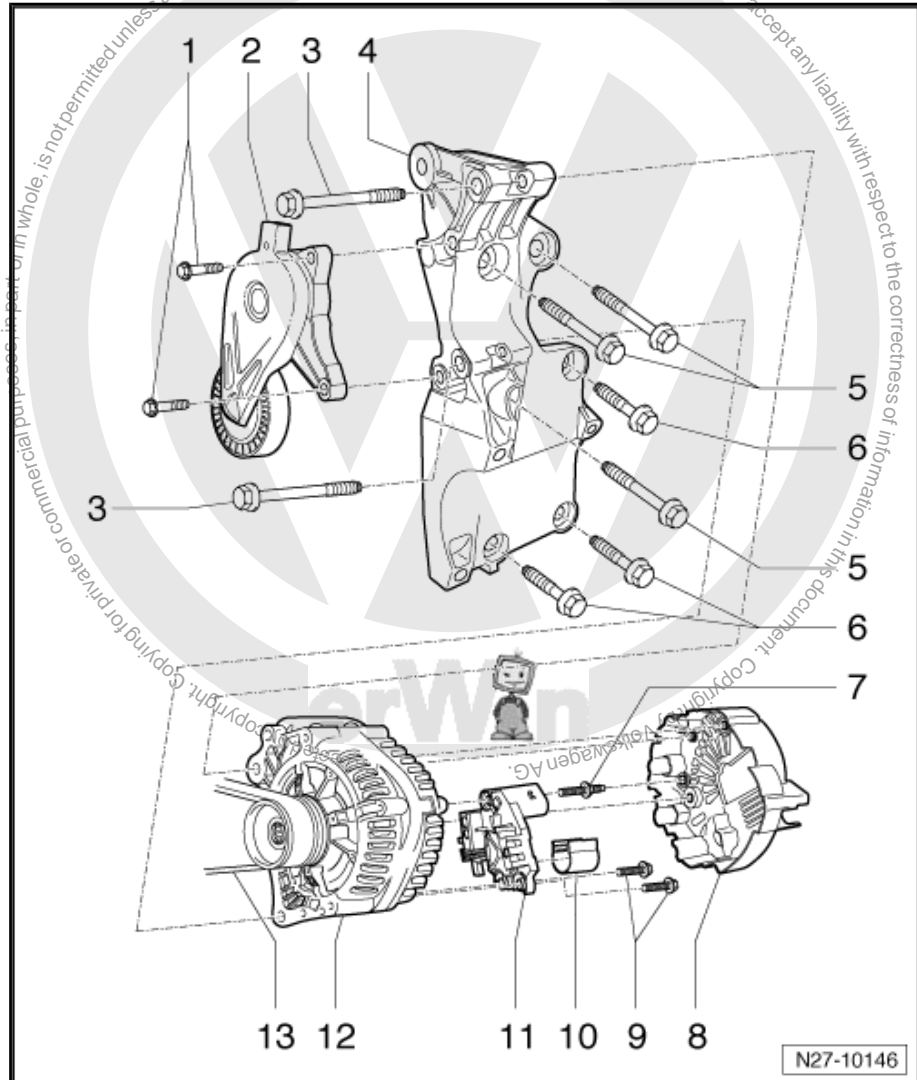

N27-10146



9.9.2 Removing and installing alternator, 1.9 I TDI engine



Caution

Disconnecting and connecting the battery as described in the Workshop Manual ⇒ [page 29](#).

Removing:

Special tools and workshop equipment required

- ◆ Torque wrench -V.A.G 1331-

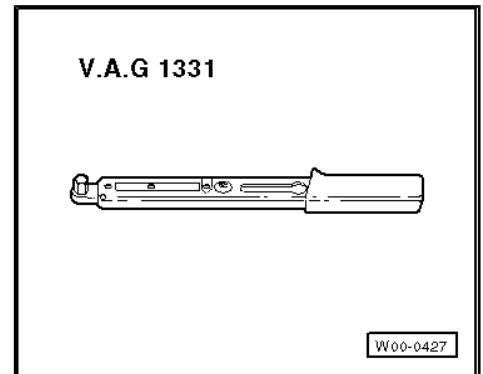

- ◆ Locking pin -T10060 A-

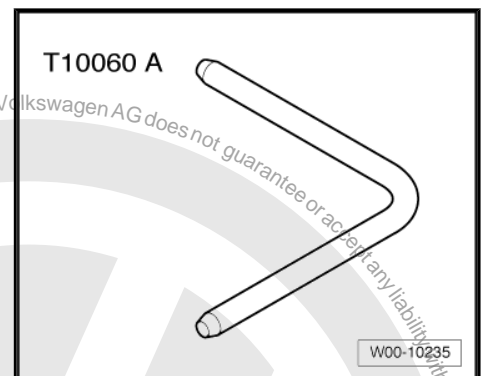

- Disconnect the battery ⇒ [page 29](#) .
- Pull engine cover upwards -arrows A- and forwards -arrow B-.

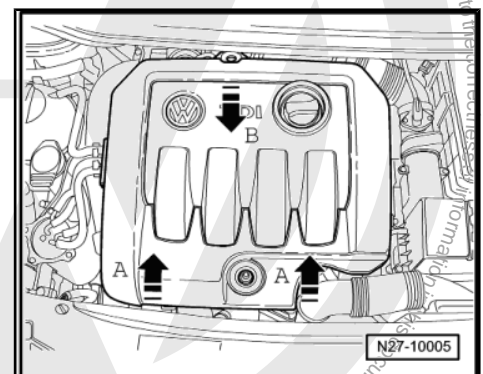



Note

- ◆ All hoses of the charge air system are secured with hose clips or with quick release couplings. When using quick release couplings the following points must be observed:
- ◆ Unlock connection by pulling the securing clamp -arrow-.
- ◆ Pull hose/tube off without assistance of tools.

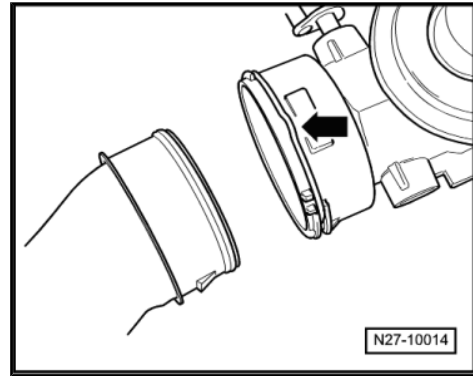

- Disconnect connectors -1-.
- Unclip fuel hoses -2- and take charge air hose out.

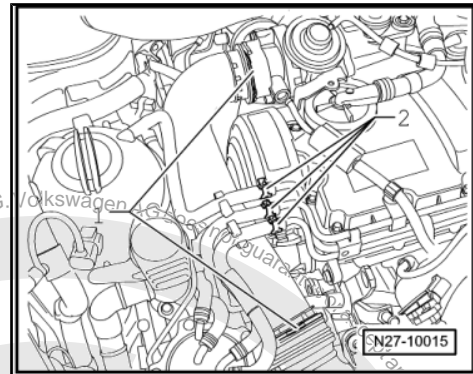

- Pull vacuum hose -1- off.
- Disconnect connector -2-.
- Remove securing bolt -3-.

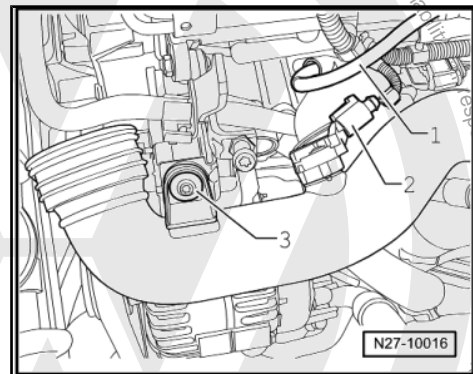

- Unbolt securing bolt -arrow-.
- Remove noise insulation ⇒ General Body Repairs, Exterior;
Rep. Gr. 50 ; Body front; Noise insulation .

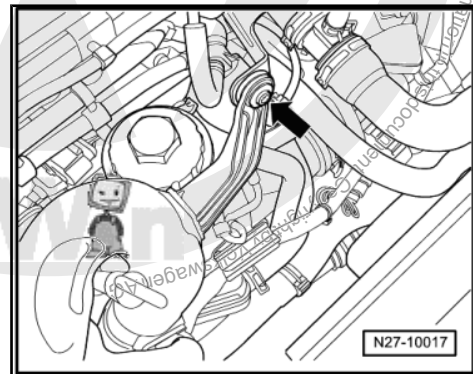



- Unscrew charge air pipe securing bolt -arrow-.

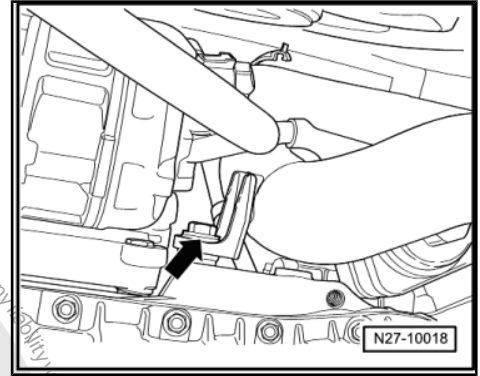

- Disconnect connector of charge air pipe -arrow-.
- Take charge air pipe out upwards.

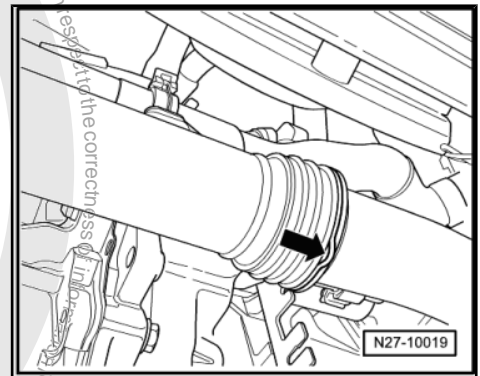

- Disconnect connector of DF wiring -1- and pull protective cap -2- off.

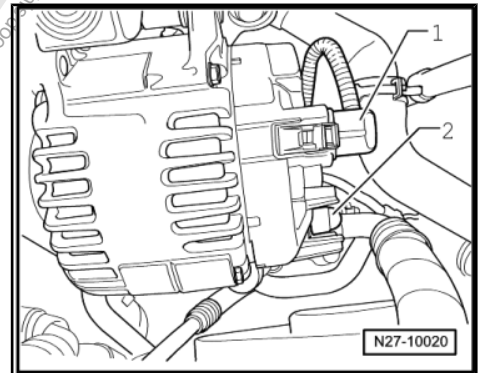

- Unscrew B+ wiring -arrow- off alternator.
- Pull fuel filter off the retainer and place to side (fuel hoses remain connected).

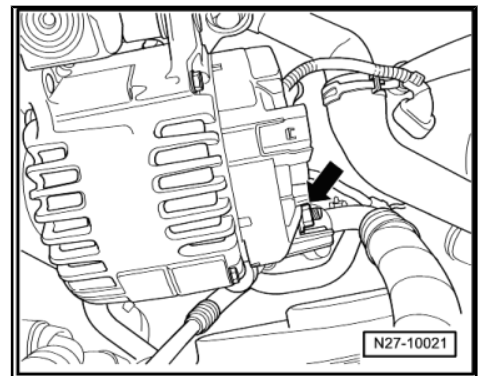

Caution

Mark top and direction of rotation of poly V-belt before removing. When installing observe direction of rotation marked on removal. Installing opposite to the direction of rotation leads to belt damage!

- Mark direction of rotation of poly V-belt.



- Release poly V-belt by turning the tensioning device with an open-ended spanner AF 16 in -direction of arrow-.

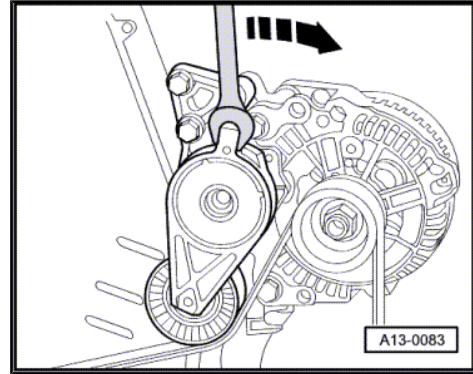

- Lock tensioning element with retaining pin -T10060 A- .
- Remove ribbed belt.

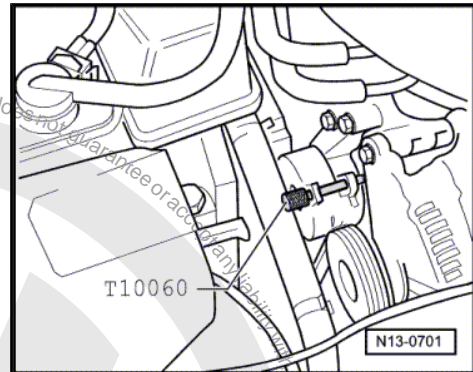

- Remove alternator securing bolts -arrows-.

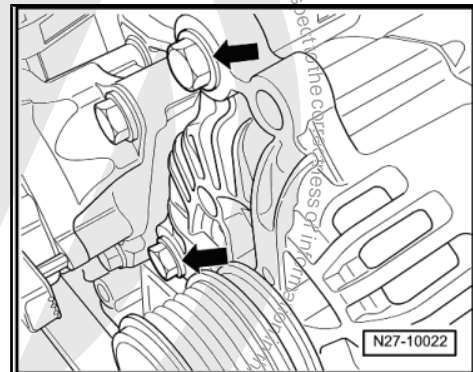

- Unscrew wiring bracket from alternator -arrow-.
- Remove alternator.

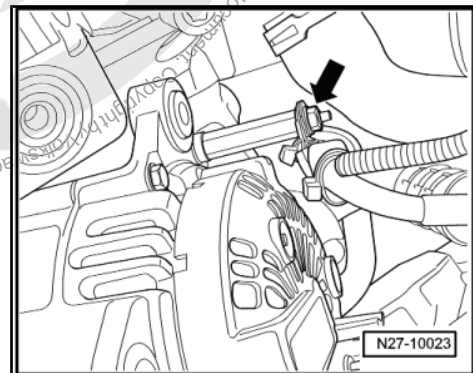

Installing:

Installation is carried out in the reverse order. When installing, note the following:



Caution

- ◆ *When reinstalling used ribbed belts (poly V-belts) observe the direction of rotation marked on removal!*
- ◆ *Ensure, before installing ribbed belt, that all ancillaries (alternator, air conditioner compressor) are secured tightly.*
- ◆ *Ensure ribbed belt (poly V-belt) is seated correctly in belt pulley when installing.*



- Drive threaded sleeves -A- out of the alternator housing for approx. 4 mm in -direction of arrow-.

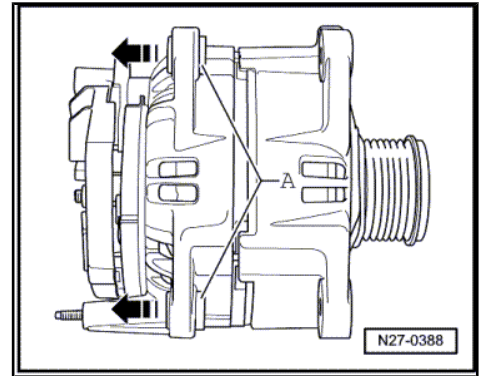

- Position wiring bracket -arrow- on rear of generator at 9 o'clock.

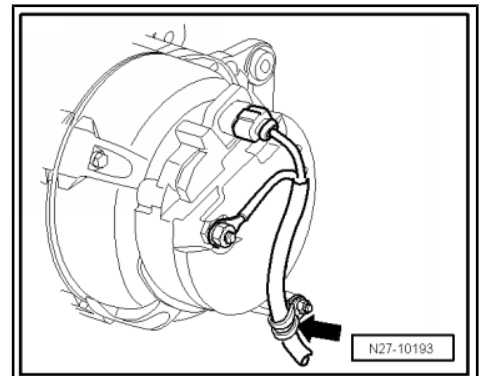

Note

- ◆ All hoses of the charge air system are secured with hose clips or with quick release couplings. When using quick release couplings the following points must be observed:
 - ◆ Fit hose/tube without assistance of tools.
 - ◆ Check for secure fit of the lugs -arrow-.
- Tighten threaded connections to specified torque settings
⇒ [page 145](#).



Caution

Observe instructions on connecting battery terminals
⇒ [page 4](#).

- Connect the battery ⇒ [page 29](#).
- Start the engine and check belt running.
- Switch off the engine.



9.9.3 Ribbed belt routing, 1.9 TDI engine

Models without air conditioning system:

- 1 - Tensioning roller
- 2 - Ribbed belt pulley - Alternator
- 3 - Poly V-belt
- 4 - Ribbed belt pulley - Crankshaft

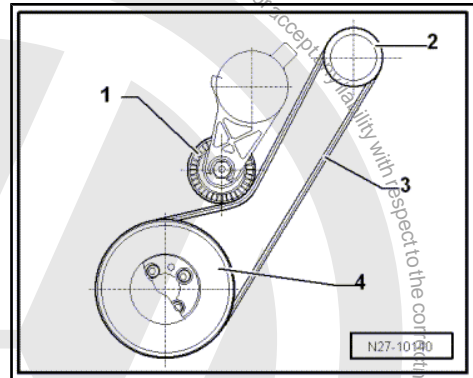

Models with air conditioning system:

- 1 - Tensioning roller
- 2 - Ribbed belt pulley - Alternator
- 3 - Ribbed belt pulley - Air conditioner compressor
- 4 - Poly V-belt
- 5 - Ribbed belt pulley - Crankshaft

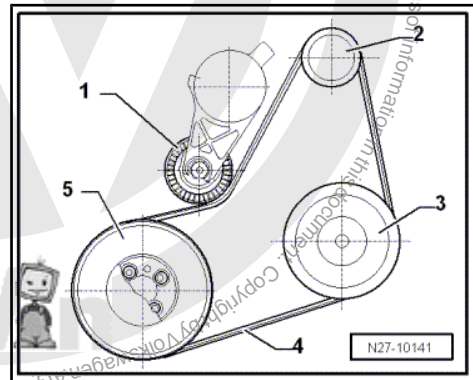



9.10 Alternator, 2,0 I TDI engine

9.10.1 Assembly overview

1 - Hexagon head collared bolts

- M8x45
- 20 Nm

2 - Tensioning element for poly V-belt

3 - Hexagon head collared bolts

- M8x90
- 20 Nm

4 - Compact bracket

- For alternator and air conditioner compressor
- Tightening sequence ⇒ [page 148](#)

5 - Hexagon head collared bolts

- M10x65
- 40 Nm

6 - Hexagon head collared bolts

- M10x45
- 40 Nm

7 - Phillips screws

- M4x20
- 2 Nm

8 - Protective cap

9 - Voltage regulator

- Removing and installing voltage regulator ⇒ [page 142](#)

10 - Alternator

- Removing and installing alternator ⇒ [page 133](#)

11 - Poly V-belt

- Checking ⇒ [page 98](#) .

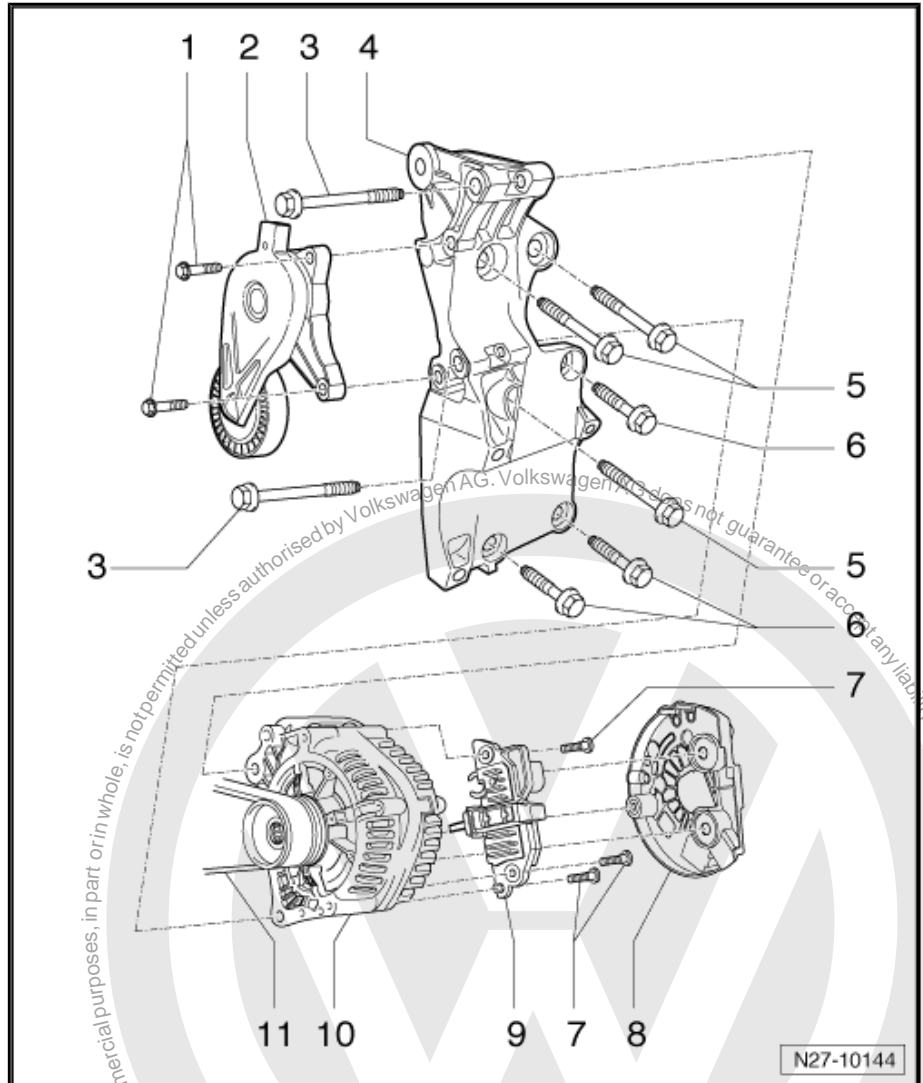

9.10.2 Removing and installing alternator, 2,0 I TDI engine



Caution

Disconnecting and connecting the battery as described in the Workshop Manual ⇒ [page 29](#) .



Removing:

Special tools and workshop equipment required

- ◆ Torque wrench -V.A.G 1331-

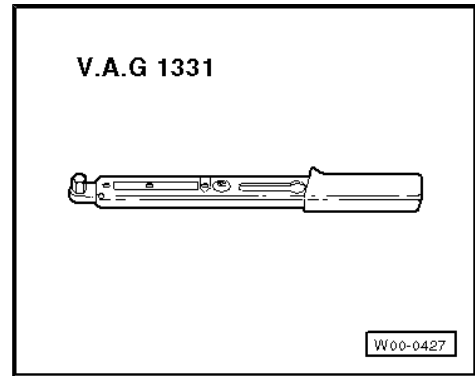

- ◆ Locking pin -T10060 A-

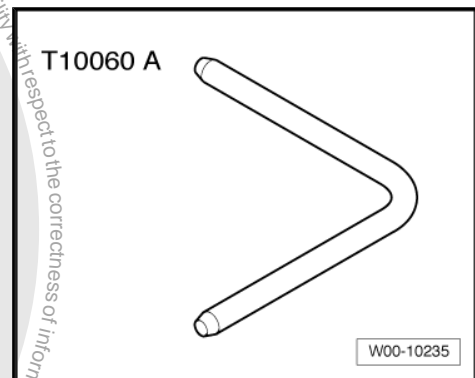

- Disconnect the battery ⇒ [page 29](#) .
- Pull engine cover off upwards -arrows-.

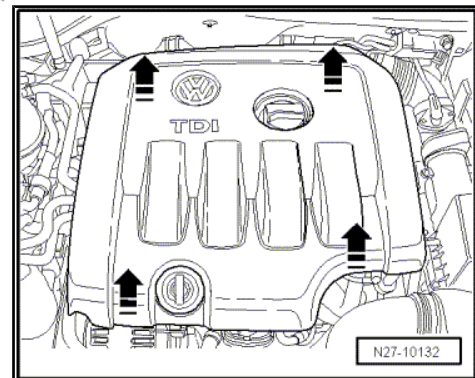

- Pull vacuum hoses off -arrow-.

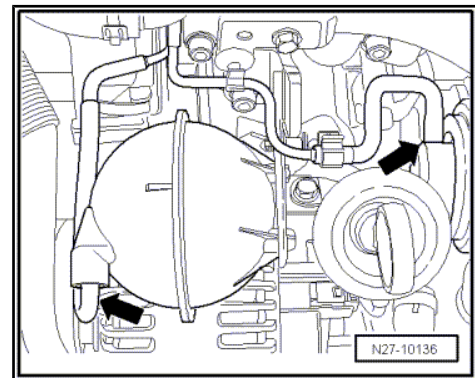



- Unbolt securing bolts -arrow-.

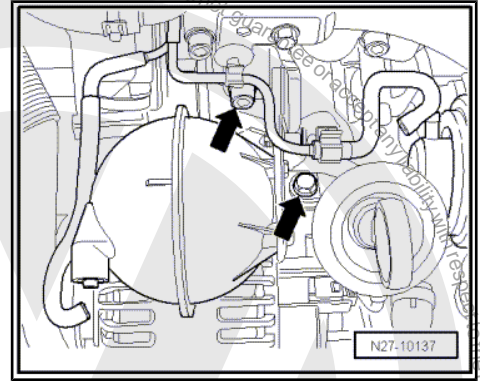

- Disconnect connector of DF wiring -1- and pull protective cap -2- off.

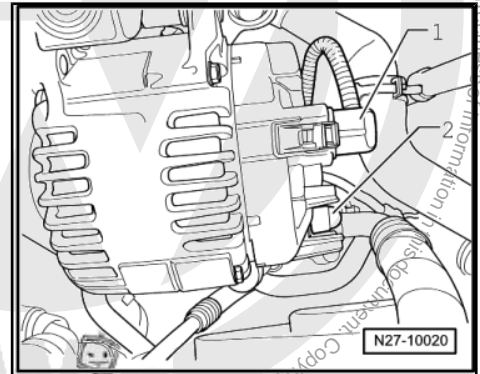

- Unscrew B+ wiring -arrow- off alternator.
- Pull fuel filter off the retainer and place to side (fuel hoses remain connected).

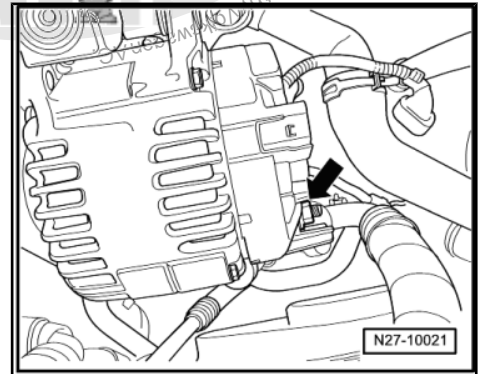

 **Caution**
Mark top and direction of rotation of poly V-belt before removing. When installing observe direction of rotation marked on removal. Installing opposite to the direction of rotation leads to belt damage!

- Mark direction of rotation of poly V-belt.
- Release poly V-belt by turning the tensioning device with an open-ended spanner AF 16 in -direction of arrow-.

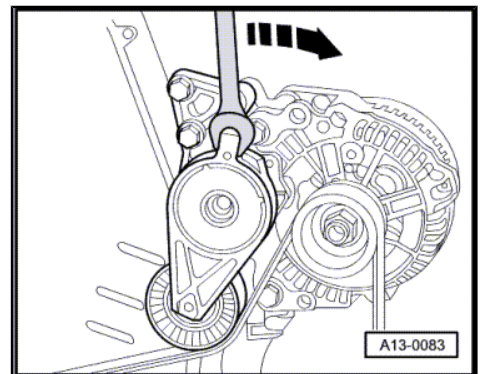



- Lock tensioning element with retaining pin -T10060 A- .
- Remove ribbed belt.

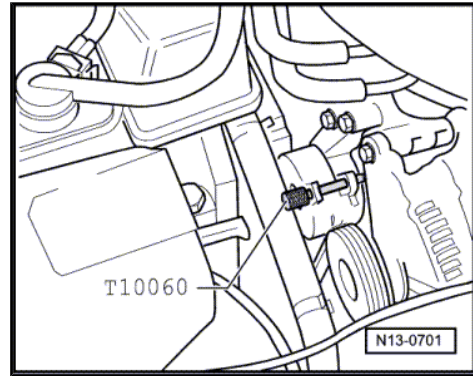

- Remove alternator securing bolts -arrows-.

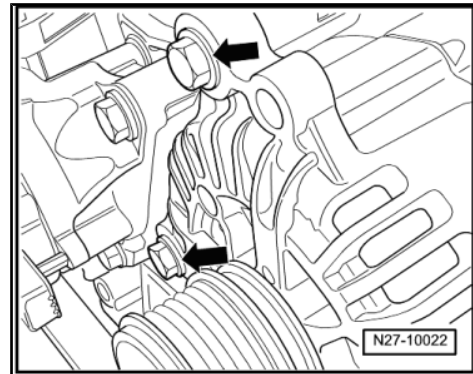

- Unscrew wiring bracket -arrow- from alternator.
- Remove alternator.

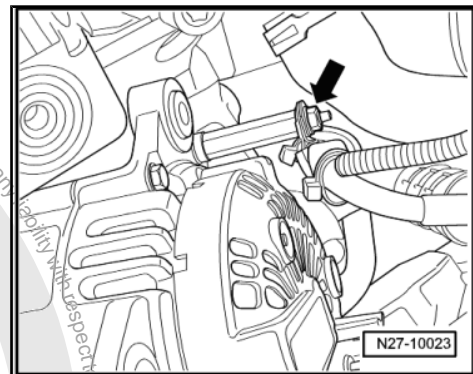

Installing:

Installation is carried out in the reverse order. When installing, note the following:



Caution

- ◆ **When reinstalling used ribbed belts (poly V-belts) observe the direction of rotation marked on removal!**
- ◆ **Ensure, before installing ribbed belt, that all ancillaries (alternator, air conditioner compressor) are secured tightly.**
- ◆ **Ensure ribbed belt (poly V-belt) is seated correctly in belt pulley when installing.**

- Drive threaded sleeves -A- out of the alternator housing for approx. 4 mm in -direction of arrow-.

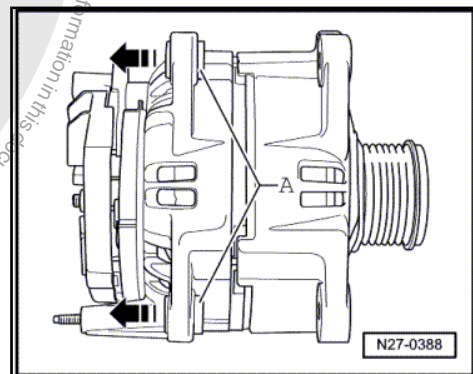



- Position wiring bracket -arrow- on rear of generator at 9 o'clock.
- Tighten threaded connections to specified torque settings
=> page 145 .



Caution

*Observe instructions on connecting battery terminals
=> page 4 .*

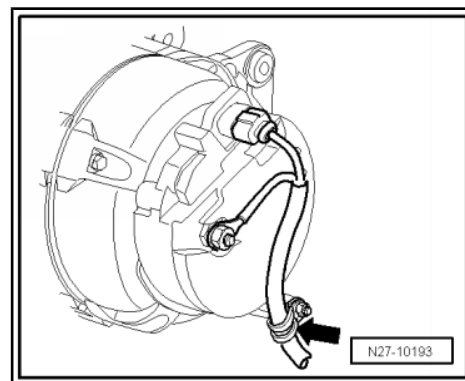

- Connect the battery => page 29 .
- Start the engine and check belt running.
- Switch off the engine.

9.10.3 Ribbed belt routing, 2,0 I TDI engine

Models without air conditioning system:

- 1 - Tensioning roller
- 2 - Ribbed belt pulley - Alternator
- 3 - Poly V-belt
- 4 - Ribbed belt pulley - Crankshaft

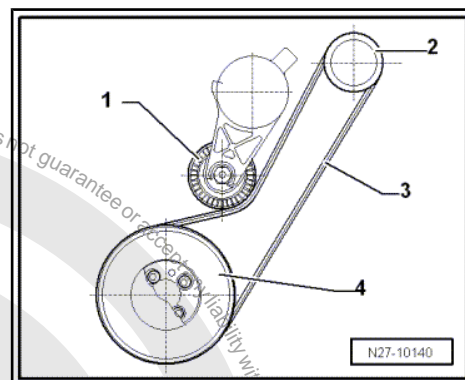

Models with air conditioning system:

- 1 - Tensioning roller
- 2 - Ribbed belt pulley - Alternator
- 3 - Ribbed belt pulley - Air conditioner compressor
- 4 - Poly V-belt
- 5 - Ribbed belt pulley - Crankshaft

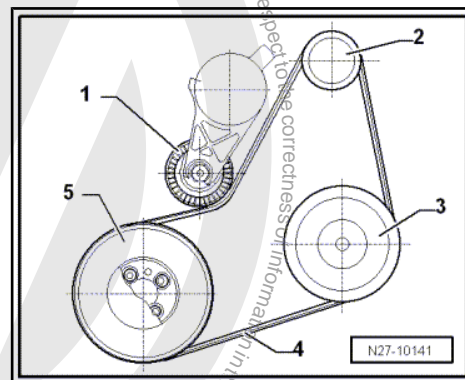

9.11 Removing and installing ribbed belt (poly V-belt) pulley on alternator

9.11.1 Removing and installing a ribbed belt (poly V-belt) pulley with no freewheel

Special tools and workshop equipment required



◆ Socket -VAS 3310-

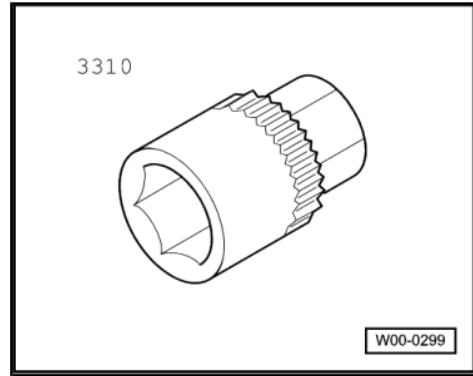

◆ Torque wrench -V.A.G 1332-

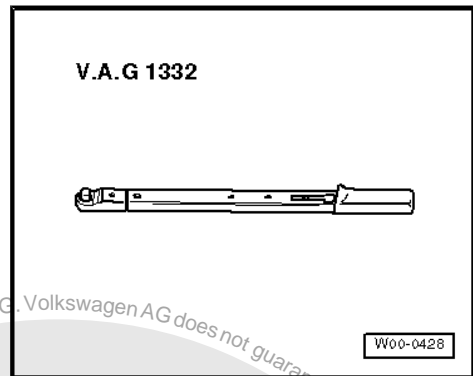

Removing:

- Take off alternator ⇒ [page 98](#) .
- Fit alternator in a vice on fitting points.
- Use socket -VAS 3310- to remove ribbed belt (poly V-belt) pulley securing nut from alternator shaft.

Installing:

Installation is performed in the reverse order of installation; when doing this, note the following:

- Tighten threaded connections to specified torque settings ⇒ [page 145](#) .

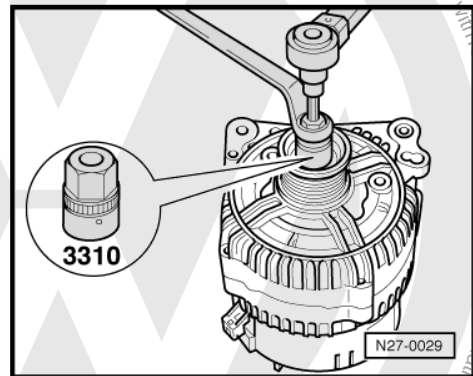

9.11.2 Removing and installing a ribbed belt (poly V-belt) pulley with freewheel, manufacturer: Bosch

Special tools and workshop equipment required



◆ Adapter -VAS 3400-

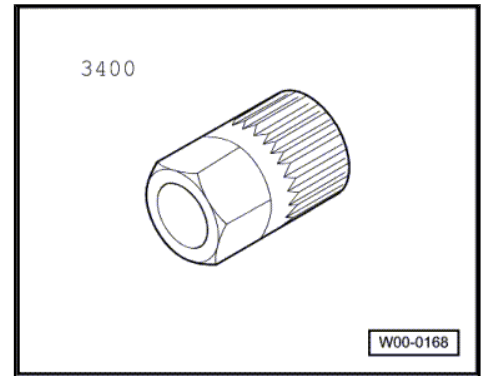

◆ Torque wrench -V.A.G 1332-

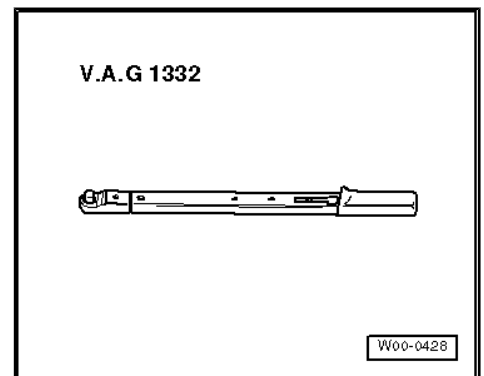

Removing:

- Take off alternator ⇒ [page 98](#) .
- Fit alternator in a vice on fitting points.
- Take protective cap off ribbed belt (poly V-belt) pulley with freewheel.



Note

The thread on the alternator shaft is a left-hand thread, i.e. turn to right when loosening and to left when tightening the threaded joint.

- Fit adapter -VAS 3400- in the ribbed belt (poly V-belt) pulley with a freewheel of the alternator with a ring spanner AF 17.

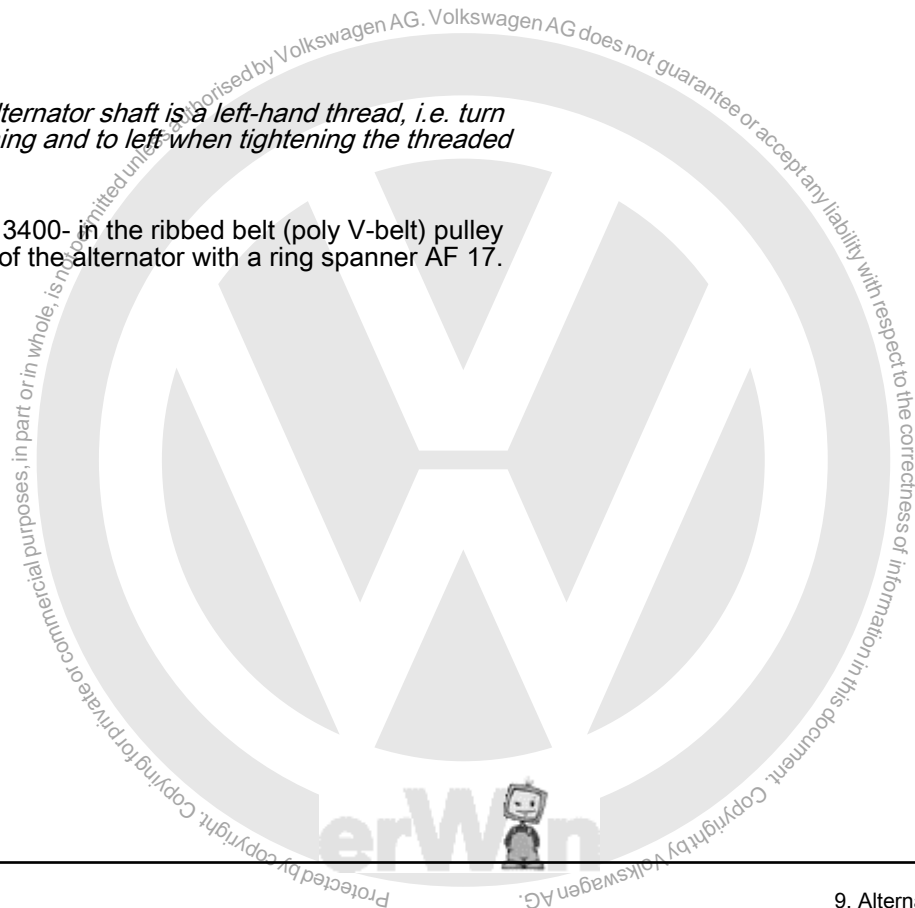



- Insert a socket M10 -1- in the alternator shaft.
- Loosen threaded joint by turning to right and counter-hold with ring spanner.
- Hold the ribbed belt (poly V-belt) pulley with a freewheel with the hand and turn the drive shaft of the alternator until the ribbed belt (poly V-belt) pulley with a freewheel can be taken off.

Installing:

Installation is carried out in the reverse order. When installing, note the following:

- At first screw the ribbed belt (poly V-belt) pulley with a freewheel on the drive shaft of the alternator by hand to limit stop.

The torque wrench -V.A.G 1332- must be rearranged before installing the ribbed belt (poly V-belt) pulley with a freewheel as follows:

- Release socket -1- and pull off grip -2-.
- Turn the torque wrench grip -2- through 180 degrees and re-insert socket drive.
- Set torque wrench direction of rotation on socket to left.

- Insert a socket M10 -1- in the alternator shaft.
- Counter-hold adapter -VAS 3400- with ring spanner, AF 17.
- Tighten the ribbed belt (poly V-belt) pulley with a freewheel by turning the alternator drive shaft to left using torque wrench -V.A.G 1332- .
- Tighten threaded connections to specified torque settings
⇒ [page 145](#) .

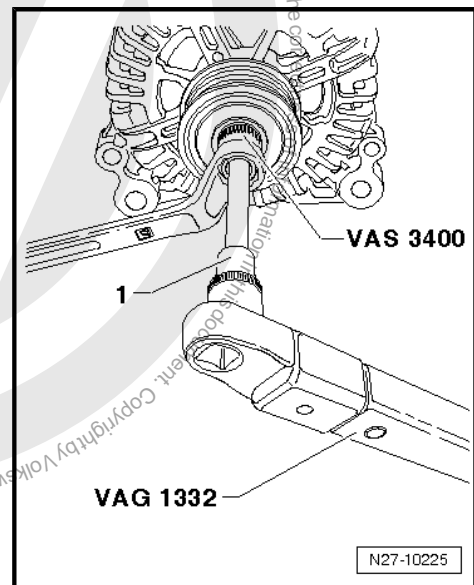
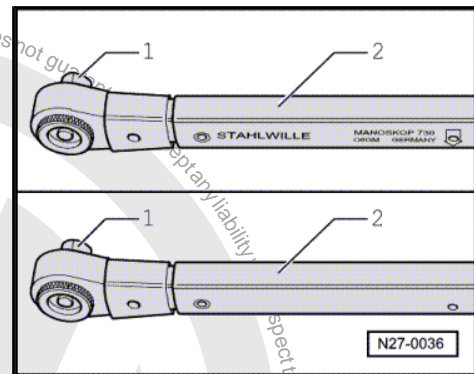
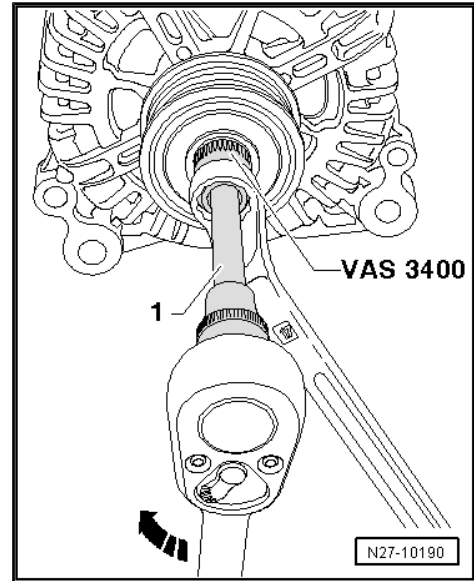





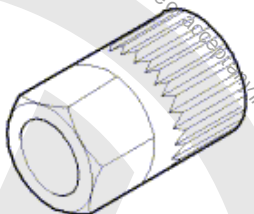

9.11.3 Removing and installing a ribbed belt (poly V-belt) pulley with freewheel, manufacturer: Valeo

Special tools and workshop equipment required

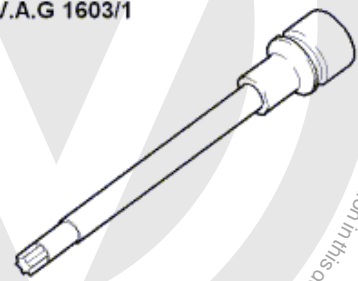
- ◆ Adapter -VAS 3400-
- ◆ Torque wrench -V.A.G 1332-
- ◆ TORX key -V.A.G 1603/1-

<p>3400</p> 	<p>V.A.G 1332</p> 
<p>V.A.G 1603/1</p> 	
	<p style="text-align: right;">W27-10006</p>

Removing:

- Take off alternator ⇒ [page 98](#) .
- Fit alternator in a vice on fitting points.
- Take protective cap off ribbed belt (poly V-belt) pulley with freewheel.



Note

The thread on the alternator shaft is a left-hand thread, i.e. turn to right when loosening and to left when tightening the threaded joint.

- Fit adapter -VAS 3400- in the ribbed belt (poly V-belt) pulley with a freewheel of the alternator with a ring spanner AF 17.



- Fit TORX key -V.A.G 1603/1- into alternator shaft.
- Loosen threaded joint by turning to right and counter-hold with ring spanner.
- Hold the ribbed belt (poly V-belt) pulley with a freewheel with the hand and turn the drive shaft of the alternator until the ribbed belt (poly V-belt) pulley with a freewheel can be taken off.

Installing:

Installation is carried out in the reverse order. When installing, note the following:

- At first screw the ribbed belt (poly V-belt) pulley with a freewheel on the drive shaft of the alternator by hand to limit stop.

The torque wrench -V.A.G 1332- must be rearranged before installing the ribbed belt (poly V-belt) pulley with a freewheel as follows:

- Release socket -1- and pull off grip -2-.
- Turn the torque wrench grip -2- through 180 degrees and reinsert socket drive.
- Set torque wrench direction of rotation on socket to left.

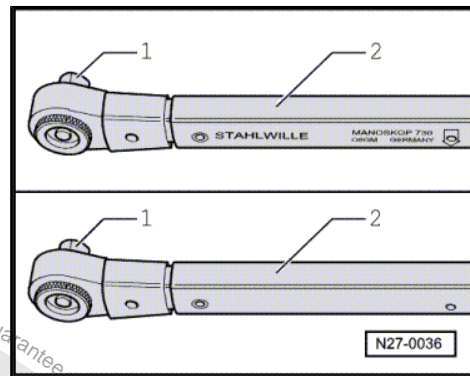
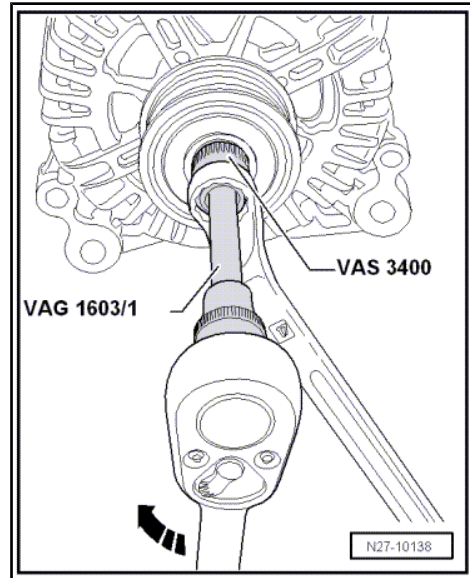

- Fit TORX key -V.A.G 1603/1- into alternator shaft.
- Counter-hold adapter -VAS 3400- with ring spanner, AF 17.
- Tighten the ribbed belt (poly V-belt) pulley with a freewheel by turning the alternator drive shaft to left using torque wrench -V.A.G 1332-.
- Tighten threaded connections to specified torque settings => [page 145](#).

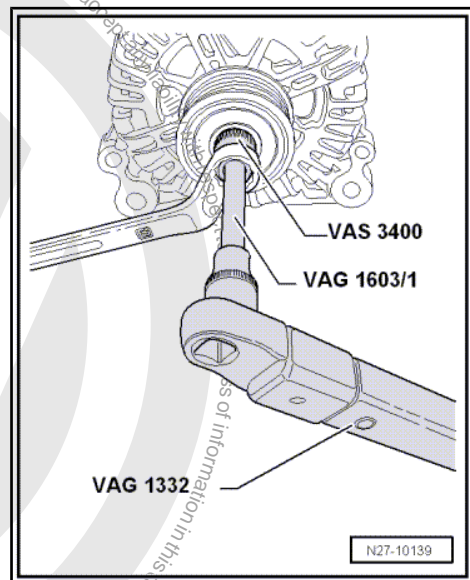

9.12 Voltage regulator for alternator

9.12.1 Removing and installing voltage regulator, manufacturer: Bosch

Special tools and workshop equipment required



- ◆ Torque screwdriver -V.A.G 1624-

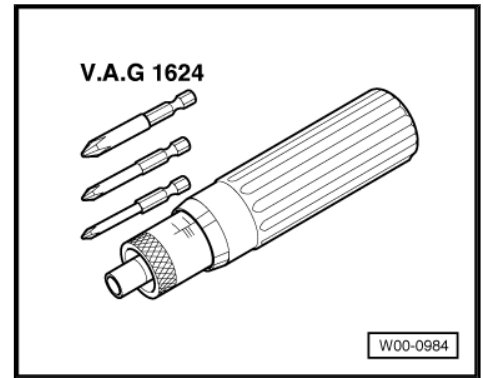

Removing:

- Remove alternator.
- Remove securing bolt and nuts -arrows- and take protective cap off alternator.

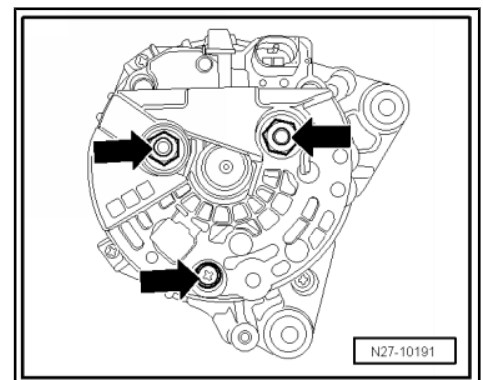

- Remove securing bolts for voltage regulator -arrows-.
- Remove voltage regulator from alternator.

Installing:

Install in reverse order of removal.

- Tighten threaded connections to specified torque settings
→ [page 145](#) .

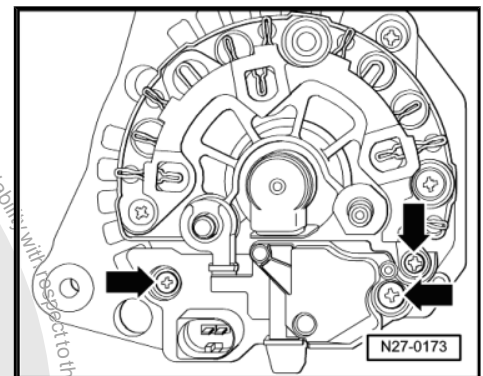

9.12.2 Removing and installing voltage regulator, manufacturer: Valeo

Special tools and workshop equipment required

- ◆ Torque wrench -V.A.G 1783/-

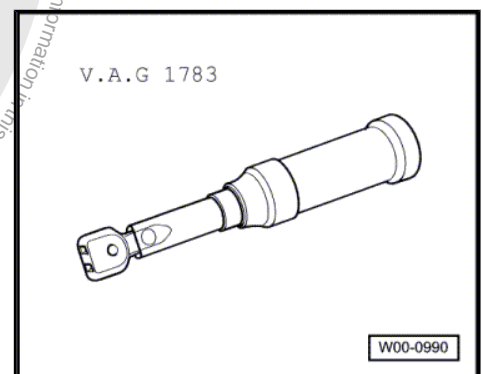



Removing:

- Remove alternator.
- Remove spring clips -arrows- and take protective cap off alternator.

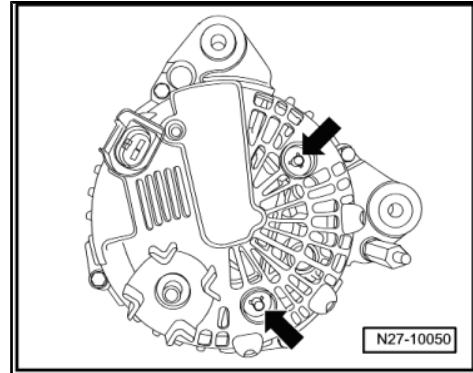

- Remove securing bolts for voltage regulator -arrows-.
- Remove voltage regulator from alternator.

Installing:

Installation is carried out in the reverse order. When installing, note the following:

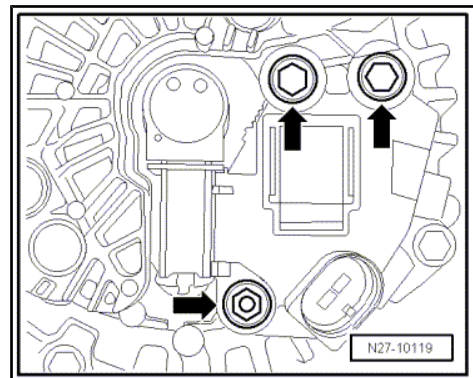

- Release locking lugs -arrow- and pull protective cap off voltage regulator.
- Push voltage regulator carbon brushes in housing of voltage regulator and place voltage regulator in alternator.
- Tighten threaded connections to specified torque settings
⇒ [page 145](#) .

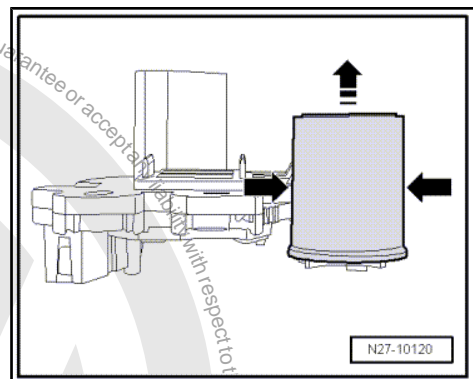

- Push protective cap into guides -arrows- until it audibly engages.

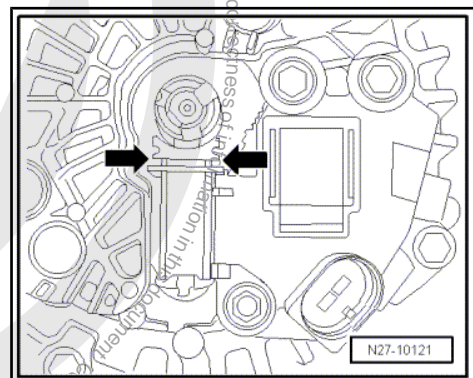



10 Torque settings: alternator

10.1 General torque settings for all vehicles

Threaded connections		Torque settings
B+ wire to alternator	M8	15 Nm
Cable holder to alternator	M5	3,2 Nm
Voltage regulator to alternator	M4	2 Nm
Protective cap to alternator	M5	4.5 Nm
Poly V-belt pulley with freewheel to alternator	M10	80 Nm
Poly V-belt pulley without freewheel to alternator	M10	65 Nm

10.2 1.6 l injection engine and 2.0 l FSI engine



Caution

In order to avoid damage to cylinder block and compact bracket, you must respect the tightening sequence for the compact bracket.

10.2.1 Torque settings

Threaded connections		Torque settings
Alternator to compact bracket	M8	23 Nm
Tensioning element to compact bracket	M8x50	23 Nm
Compact bracket to cylinder block	M10x45	52 Nm

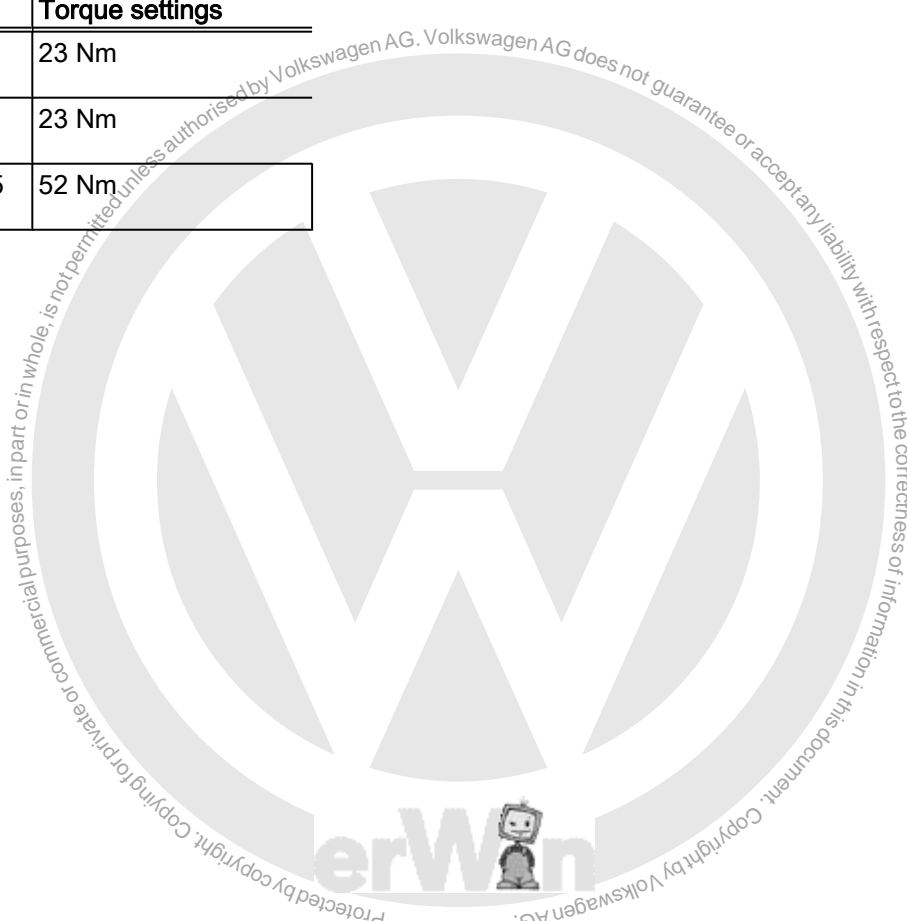



10.2.2 Tightening sequence for compact bracket, models with air conditioning system

Tightening sequence for compact bracket to cylinder block

Procedure

- Place compact bracket on cylinder block.



Note

Before tightening to specified torque setting, screw in all bolts by hand.

- Tighten securing bolts of compact bracket in following sequence:

- A - Hexagon head collared bolt, M10x45, 52 Nm, locating hole
- B - Hexagon head collared bolt, M10x45, 52 Nm
- C - Hexagon head collared bolt, M10x45, 52 Nm
- D - Hexagon head collared bolt, M10x45, 52 Nm
- E - Hexagon head collared bolt, M10x45, 52 Nm
- F - Hexagon head collared bolt, M10x45, 52 Nm

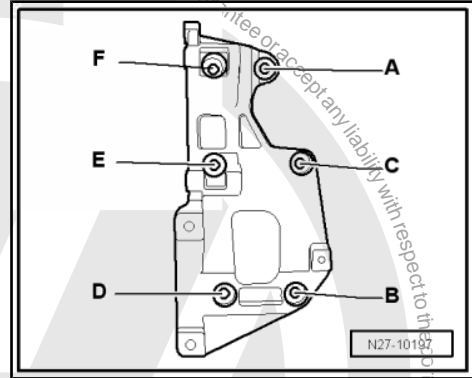

10.3 2.0 | FSI turbo engine



Caution

In order to avoid damage to cylinder block and compact bracket, you must respect the tightening sequence for the compact bracket.

10.3.1 Torque settings

Threaded connections		Torque settings
Alternator to compact bracket	M8x90	23 Nm
Tensioning element to compact bracket	M8x90	23 Nm
Compact bracket to cylinder block	M10x45	40 Nm
Air conditioner compressor to compact bracket	M8x100	23 Nm



10.3.2 Tightening sequence for compact bracket, models with air conditioning system

Tightening sequence for compact bracket to cylinder block

Procedure

- Place compact bracket on cylinder block.



Note

Before tightening to specified torque setting, screw in all bolts by hand.

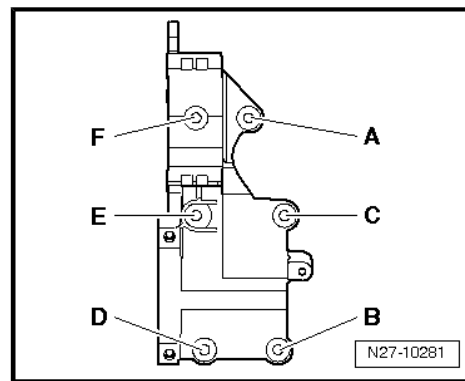

- Tighten securing bolts of compact bracket in following sequence:

A - Cylinder collar screw, M10x45, 40 Nm, locating hole

B - Cylinder collar screw, M10x45, 40 Nm

C - Cylinder collar screw, M10x45, 40 Nm

D - Cylinder collar screw, M10x45, 40 Nm

E - Cylinder collar screw, M10x45, 40 Nm

F - Cylinder collar screw, M10x45, 40 Nm

10.4 1.9 l and 2.0 l TDI engine



Caution

In order to avoid damage to cylinder block and compact bracket, you must respect the tightening sequence for the compact bracket.

10.4.1 Torque settings

Threaded connections		Torque settings
Alternator to compact bracket	M8x90	20 Nm
Tensioning element to compact bracket	M8	20 Nm
Compact bracket to cylinder block	M10	40 Nm



10.4.2 Tightening sequence for compact bracket

Tightening sequence for compact bracket to cylinder block

Procedure

- Place compact bracket on cylinder block.



Note

- ◆ *Observe dowel sleeve between compact bracket and cylinder block.*
- ◆ *Before tightening to specified torque setting, screw in all bolts by hand.*

- Tighten securing bolts of compact bracket in following sequence:

A - Hexagon head collared bolt, M10x65, 40 Nm

B - Hexagon head collared bolt, M10x45, 40 Nm

C - Hexagon head collared bolt, M10x45, 40 Nm

D - Hexagon head collared bolt, M10x45, 40 Nm

E - Hexagon head collared bolt, M10x65, 40 Nm

F - Hexagon head collared bolt, M10x65, with dowel sleeves 40 Nm

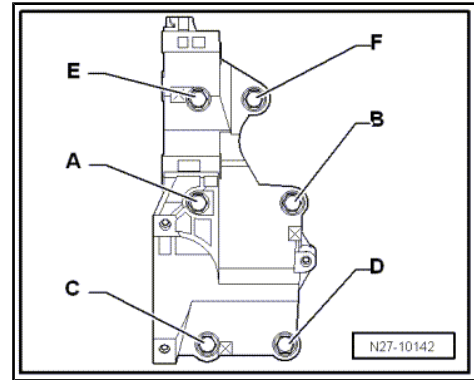

10.5 2.5 l injection engine

10.5.1 Torque settings

Threaded connections		Torque settings
Alternator to compact bracket	M8x90	25 Nm
Tensioning element to compact bracket	M8x50	23 Nm
Compact bracket to cylinder block	M10x45	52 Nm



Note

- ◆ *Observe dowel sleeve between compact bracket and cylinder block.*
- ◆ *For the compact bracket no tightening torque must be observed.*



11 Cruise control system (CCS)

General description:

The functions of the cruise control system are controlled by the engine control unit.

There are no additional components, apart from the switch for CCS -E45- , which is integrated into the "turn signal switch".

- Removing and installing switch for CCS -E45- ("turn signal switch") ⇒ [page 224](#) .
- You can activate and deactivate the cruise control system ⇒ [page 149](#) .

Fault detection and fault display:

Faults on the CCS are output via the engine control unit.

For fault finding, use the vehicle diagnosis, testing and information system -VAS 5051A- in "guided fault finding" mode.

11.1 Activating and deactivating cruise control system

- Connect Vehicle Diagnosis, Testing and Information System -VAS 5051A- ⇒ [page 281](#) .
- Select "guided fault finding" in Vehicle Diagnosis, Testing and Information System -VAS 5051A- .
- Using the "Go to" key, select "Function/component selection" and the following menu items one after the other:
 - ◆ Drive
 - ◆ Engine code
 - ◆ 01 - On Board Diagnostic capable systems
 - ◆ Engine control and/or direct diesel injection and pre-glow system
 - ◆ Function
 - ◆ Activating and deactivating cruise control system



90 – Instruments, GCI

1 Dash panel insert

General description:

Integrated in the dash panel insert are the following components:

- ◆ Control unit with display in dash panel insert -J285-
- ◆ Immobilizer control unit -J362-
- ◆ Speedometer
- ◆ Rev counter
- ◆ Fuel gauge
- ◆ Coolant temperature gauge
- ◆ Multi-function display
- ◆ Warning lamps, ⇒ [page 152](#)

To provide acoustic support to some of the visual displays, the dash panel features a warning buzzer, which is actuated by the control unit.

All warning lamps feature LEDs. No provision has been made for repair of the dash panel insert. In the event of defects, the dash panel insert is renewed as a unit ⇒ [page 150](#) .

The data bus diagnostic interface -J533- (Gateway) is an individual control unit option and not, as on other vehicles, part of the dash panel insert ⇒ [page 294](#) .

Fault detection and fault display:

The dash panel insert is equipped with self-diagnosis which makes fault finding easier.

For fault finding, use the vehicle diagnosis, testing and information system -VAS 5051A- in “guided fault finding” mode.

1.1 Renewing dash panel insert

The work sequence “Renewing dash panel insert” consists of the following work:

- ◆ If a new dash panel insert has to be installed in the vehicle, the dash panel insert control unit has to be adapted to the different vehicle equipment and the respective country variant.
- ◆ To adapt the integrated immobilizer to the engine control unit, the data of the engine control unit must be stored in the exchange dash panel insert.
- ◆ After installing a new dash panel insert, perform adaption of all vehicle keys.

Special tools and workshop equipment required



◆ Vehicle Diagnosis, Testing and Information System -VAS 5051A-

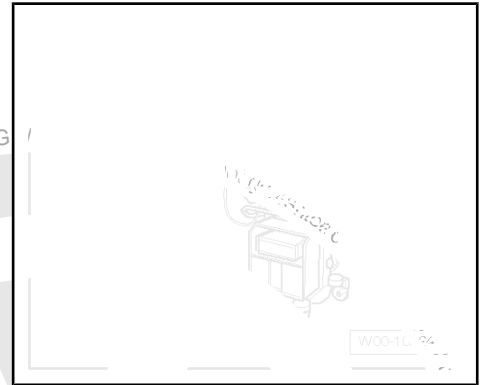

◆ Diagnosis lead -VAS 5051/6A-

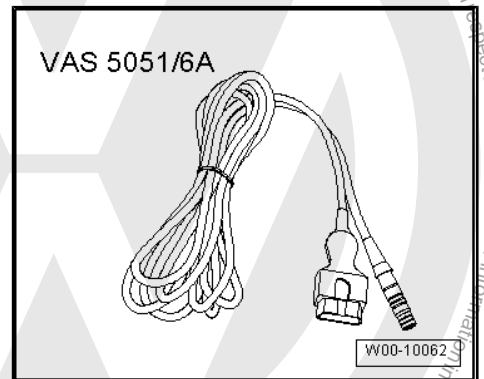

- Connect the vehicle diagnosis, testing and information system -VAS 5051A- to ⇒ [page 281](#)
- Select "guided fault finding" in Vehicle Diagnosis, Testing and Information System -VAS 5051A- .
- Using the "Go to" key, select "Function/component selection" and the following menu items one after the other:

- ◆ Body
- ◆ Electrical System
- ◆ 01 - On Board Diagnostic capable systems
- ◆ Dash panel insert
- ◆ Dash panel insert functions
- ◆ Adapting/renewing dash panel insert

1.2 Removing and installing dash panel insert



Note

Before removing the dash panel insert, the work procedure "Renewing dash panel insert" should always be carried out in order that the data stored in the control unit can be interrogated ⇒ [page 150](#) .

Removing:

- Switch off ignition and all electrical consumers and pull out ignition key.
- Remove steering wheel ⇒ General body repairs, interior; Rep. Gr. 69 ; Airbag; Removing and installing steering wheel .



- Remove the upper part of the steering column trim ⇒ General body repairs, interior; Rep. Gr. 68 ; Compartments, covers and trim; Removing and installing steering column switch trim .
- Remove securing bolts -arrows- for dash panel insert.



Note

When pulling out dash panel insert, there is no need to separate the connectors. The connections comprise of one part that is fixed to the vehicle and are thus separated automatically when the dash panel insert is pulled out.

- Pull dash panel insert out of dash panel.

Installing:

Install in reverse order of removal.

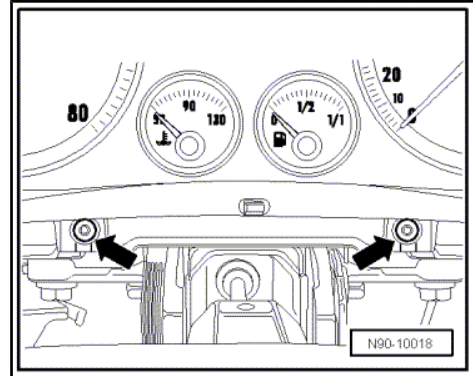

1.3 Description of reverse side of dash panel insert



Note

The dash panel insert must not be dismantled. In the event of defects, the dash panel insert is renewed as a unit.

- 1 - 36-pin connector
- 2 - Warning buzzer

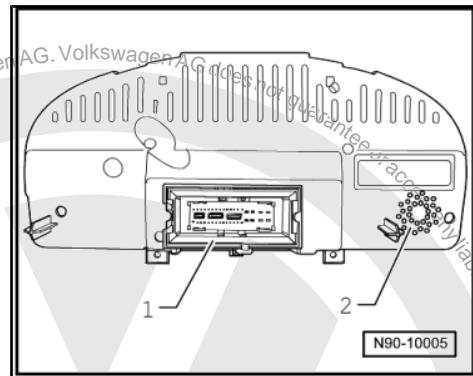

1.4 Warning lamp symbols in dash panel insert



Note

The warning lamps on the dash panel insert depend on the vehicle's equipment, country and engine type.



1 - Electric On Board Diagnosis (EOBD)

2 - Engine malfunction (EPC)

- Warning lamp is fitted only on vehicles with petrol engine.

3 - Immobilizer

4 - Battery charge

5 - Bulb failure

6 - Rear fog lights

7 - Low coolant level

8 - Brake pad wear

9 - Washer fluid level

10 - Fuel reserve

11 - Airbag display

12 - Seat belt

13 - Anti-locking brake system (ABS)

14 - Electronic stabilisation programme (ESP)

15 - Brake fault/handbrake

16 - Cruise control system (CCS)

17 - Daylight

18 - Tyre pressure monitor

19 - Water in fuel

20 - Rear seat backrest lock

21 - Shift Lock

- Warning lamp exists only on vehicles with automatic gearbox

22 - Oil level

23 - Bonnet open

24 - Door open

25 - Oil pressure

26 - Main beam

27 - Steering heating

28 - Trailer turn signals

29 - Glow plug system

- Warning lamp is fitted only on vehicles with diesel engine.

30 - Tank filler cap

31 - Exhaust filter

32 - Electronic steering (EPS-Electronic Power Steering)

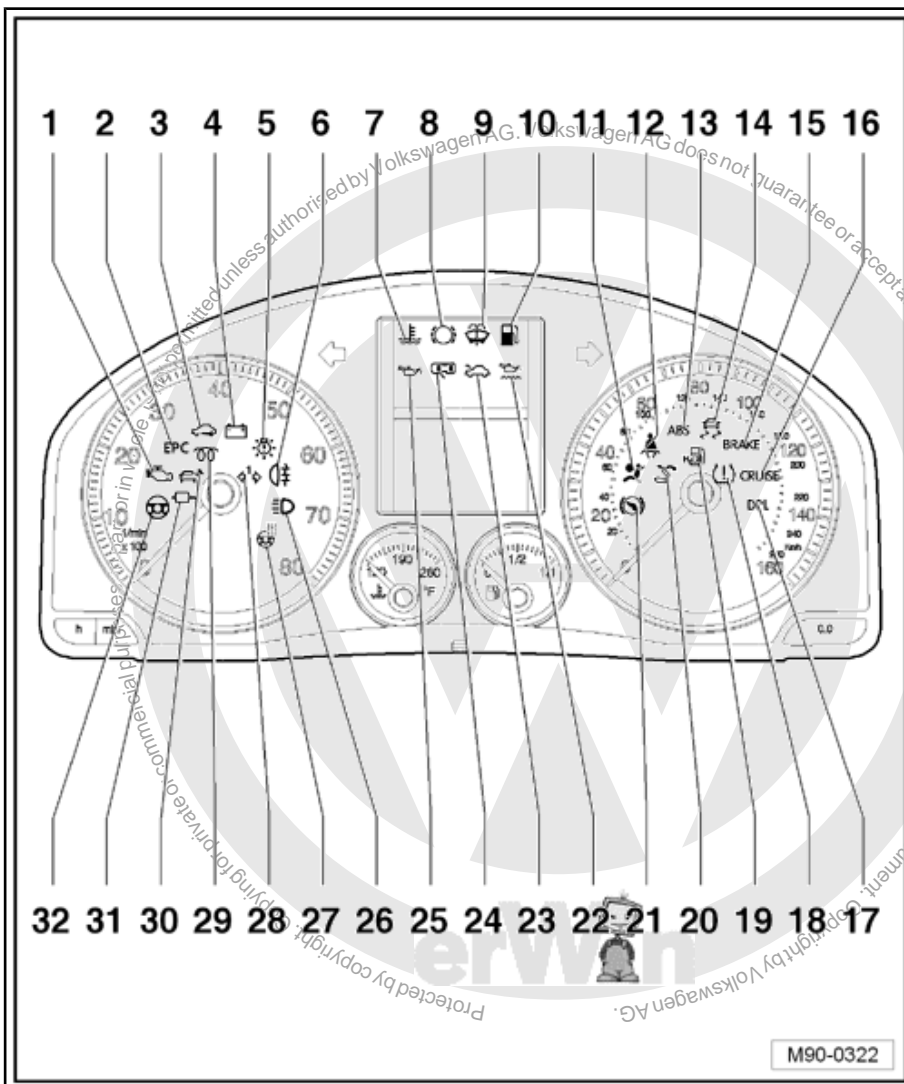

M90-0322



2 Service interval display

2.1 Resetting service interval display

⇒ Maintenance ; Booklet 20.1





92 – Windscreen wash/wipe system

1 Windscreen wiper system



Caution

Disconnecting and connecting the battery as described in the Workshop Manual ⇒ page 29 .



Note

Additional information:

⇒ Operating instructions

General description:

The wiper motor control unit -J400- and the wiper motor -V- are joined together as one unit.

To remove the wiper blades, the wiper arms should be placed in the “service/winter position”. The “service/winter position” is activated within 10 seconds after ignition is switched off by pressing windscreen wiper lever in “tip wipe” ⇒ Operating instructions for vehicle .

Fault detection and fault display:

The onboard supply control unit -J519- is equipped with self-diagnosis, which is designed to ease fault finding.

For fault finding, use the vehicle diagnosis, testing and information system -VAS 5051A- in “guided fault finding” mode.

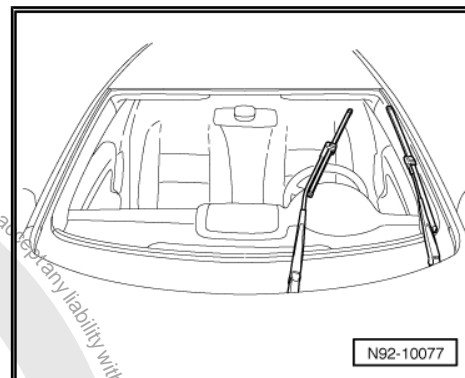

1.1 Deactivating APP function of wiper motors

Special tools and workshop equipment required

- ◆ Vehicle Diagnosis, Testing and Information System -VAS 5051A-





◆ Diagnosis lead -VAS 5051/6A-

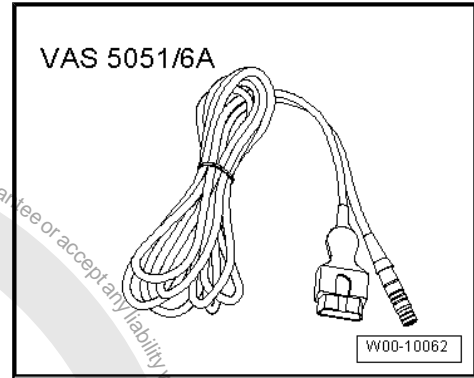

The windscreen wiper system is equipped with an APP function (alternating park position system).

With the APP function, the wiper arm is moved up slightly once it has reached the lowest position. This occurs every second time the wiper system is switched off.

To fit the crank arm on the wiper motor, it is necessary for the motor to be in the lowest park position. To ensure this position is reached, the APP function must be deactivated (code wiper motor control unit J400-).



Note

- ◆ *The APP function cannot be activated.*
- ◆ *After 100 cycles of wiper movement, the APP function is activated automatically. This applies to wiper motors on which the APP function has been deactivated and also to new wiper motors.*
- Connect the vehicle diagnosis, testing and information system -VAS 5051A- to ⇒ [page 281](#)
- Select “guided fault finding” in Vehicle Diagnosis, Testing and Information System -VAS 5051A- .
- Using the “Go to” key, select “Function/component selection” and the following menu items one after the other:
 - ◆ Body
 - ◆ Electrical System
 - ◆ 01 - On Board Diagnostic capable systems
 - ◆ Onboard supply control unit
 - ◆ Onboard supply control unit functions
 - ◆ Control unit functions for wiper electronics

1.2 Removing and installing the windscreen wiper system



Caution

Disconnecting and connecting the battery as described in the Workshop Manual ⇒ [page 29](#) .



Special tools and workshop equipment required

- ◆ Torque wrench -V.A.G 1331-
- ◆ Puller -T10130-
- ◆ Removal lever -80-200-

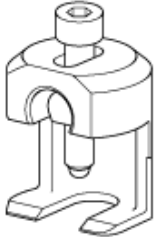
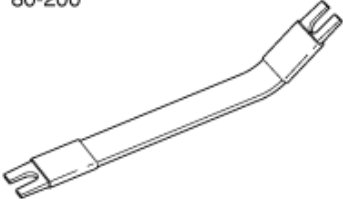
V.A.G 1331 	T10130 
80-200 	
	W27-0002

1.2.1 Removing windscreen wiper system

- Deactivating APP function ⇒ [page 155](#) .
- Allow wiper to move to park position and then switch ignition off.
- Disconnect the battery ⇒ [page 29](#) .



Note

To remove the wiper frame with rods and the wiper motor, wiper arms, plenum chamber cover and air duct cover must be removed.



1.2.2 Removing wiper arm

- Lever off the protective cap -arrows- using a screwdriver.

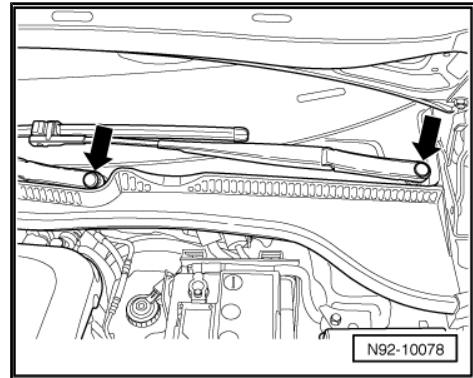

- Loosen the hexagon nut -arrows-, without removing it completely.

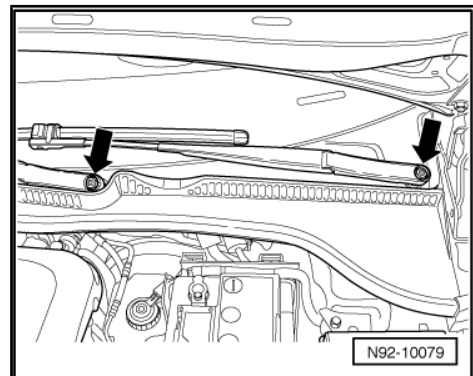

- Position legs of puller -T10130- -2- under wiper arm -4- as shown in the figure.
- Turn thrust bolt -1- of puller -T10130- clockwise until it comes into contact with the wiper shaft. The hexagon nut -3- previously loosened on the wiper arm serves as a means of centring and guiding the thrust bolt -1-.
- Turn thrust bolt -1- of puller -T10130- clockwise using 6 mm spanner until wiper arm -4- is released from the shaft.

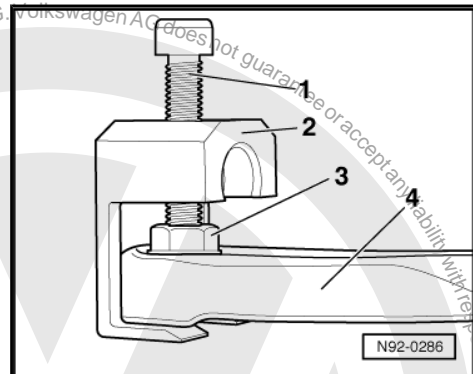

1.2.3 Removing plenum chamber cover

- Unclip plenum chamber cover -1-, starting from side, off top of windscreen frame -arrow-.

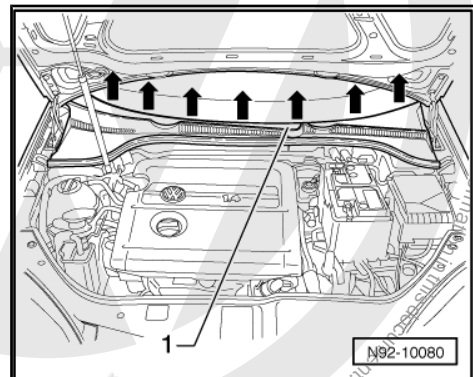



1.2.4 Removing air cowling

- Remove securing screws -1- and securing nut -2- from air cowling -3-.
- Take air cowling -3- out of vehicle.

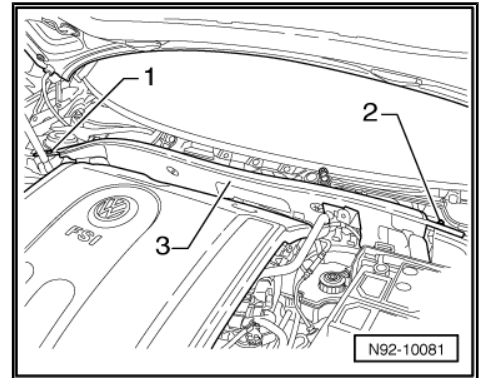

1.2.5 Removing wiper frame with linkage and wiper motor

- Disconnect connector -1-.
- Unscrew securing bolts -arrows- and pull wiper frame -2- forwards out of vehicle.

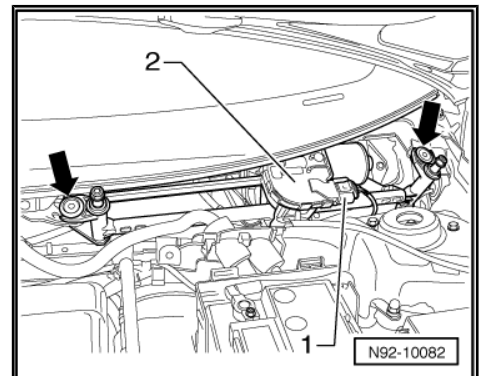

1.2.6 Removing wiper motor out of wiper frame

- Lever linkage -arrow- ball head -1- using release lever -80-200- off crank arm of motor.

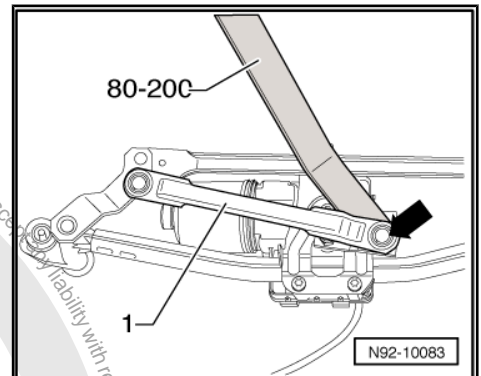

- Remove securing nut -1-.
- Pull crank -2- off wiper motor shaft.
- Unscrew securing bolts -arrows- and remove wiper motor with control unit from wiper frame.

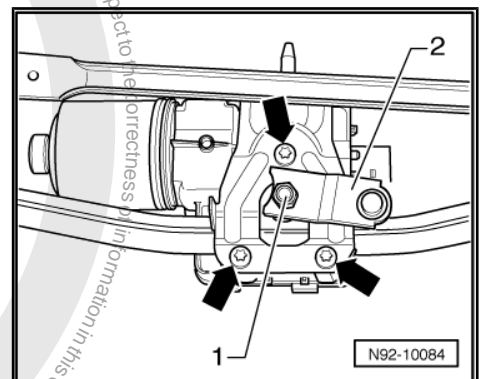



1.2.7 Installing wiper motor in wiper frame

- Insert wiper motor with control unit in wiper frame and secure it in place with the securing bolts -arrows-.
- Tighten threaded connections to specified torque settings ⇒ [page 178](#) .

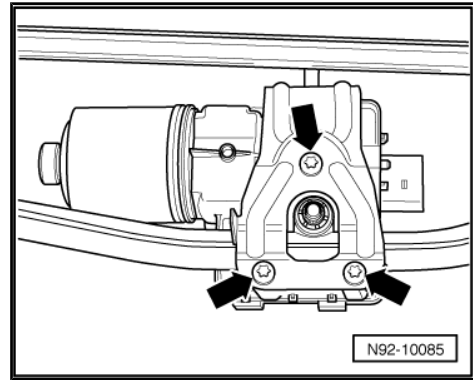

- Place crank arm of motor -1- on shaft of wiper motor. Distance -a- to limit stop -2- should be 3 ± 1 mm.
- Place crank arm of motor on shaft of wiper motor using securing nut -3-.
- Tighten threaded connections to specified torque settings ⇒ [page 178](#) .

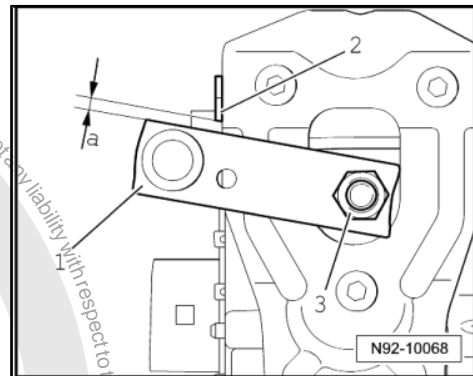

1.2.8 Installing the windscreen wiper system

- Install wiper frame in reverse order of removal. Note when installing that securing pin -2- of wiper frame must be inserted in grommet -1- in bulkhead.
- Tighten threaded connections to specified torque settings ⇒ [page 178](#) .
- Fit connector to wiper motor connection and lock in position.
- Install air cowl, plenum chamber cover and plenum chamber seal in reverse order of removal.
- Connect the battery ⇒ [page 29](#) .
- Install wiper arms ⇒ [page 160](#) .

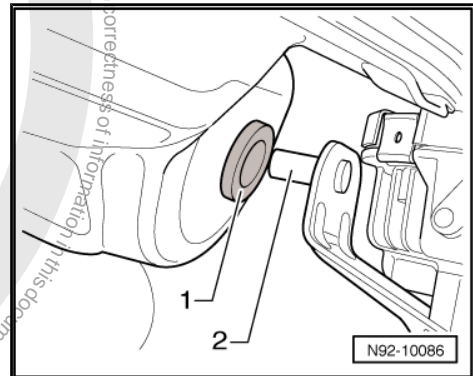

1.3 Removing and installing wiper arms

Removing:

- Removing wiper arms ⇒ [page 158](#) .

Installing:



Note

Securing nuts of wiper arms are not tightened to specified torque until after wiper blade park position has been adjusted.

- Deactivate the APP function if not already done ⇒ [page 155](#) .
- To move wiper motors to their park position, switch windscreen wipers on and off with ignition on.



- Place wiper arm in approximate park position on wiper arm shaft and tighten securing nut -arrows- by hand.
- Adjust windscreen wiper blade park position => [page 161](#) .

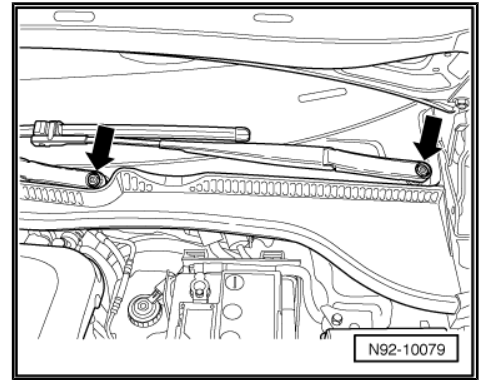

1.4 Adjusting wiper blade park position

Special tools and workshop equipment required

- ◆ Torque wrench -V.A.G 1331-

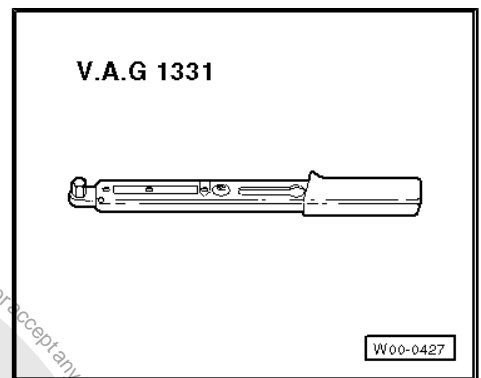

- ◆ Puller -T10130-

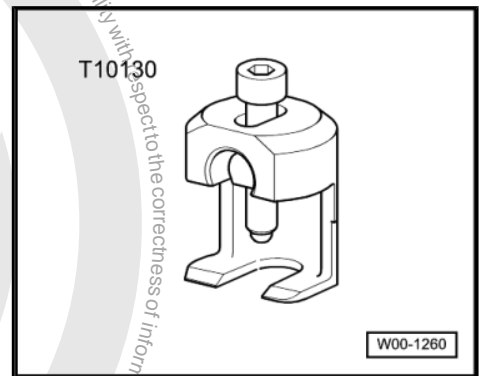

Note

On RHD vehicles, the wiper blades are a mirror image.

- Deactivate the APP function if not already done => [page 155](#)
- Allow wiper to move to park position and then switch ignition off.
- Now adjust windscreen wiper blade park position.



Driver's side:

Distance -A- between wiper blade and upper edge of plenum chamber cover should be 10 mm.

- If necessary, adjust wiper blade park position by moving wiper arm.

Removing wiper arms ⇒ [page 158](#) .

- Tighten threaded connection to specified torque setting ⇒ [page 178](#) .

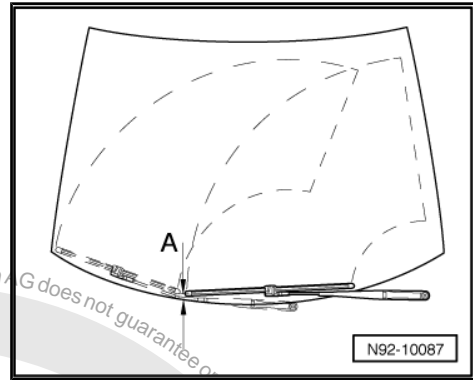

Front passenger's side:

Distance -B- between wiper blade and upper edge of plenum chamber cover should be 10 mm.

- If necessary, adjust wiper blade park position by moving wiper arm.

Removing wiper arms ⇒ [page 158](#) .

- Tighten threaded connection to specified torque setting ⇒ [page 178](#) .

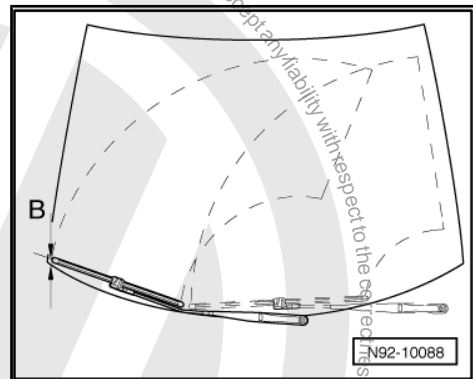

1.5 Removing and installing aerodynamic wipers

Removing:



Note

- ◆ *Driver's and front passenger wiper blades should not be interchanged during installation.*
 - ◆ *The aerodynamic wipers are very flexible. To lift the wiper blades off the windscreen, touch them only in the area in which the wiper blades are attached to the wipers.*
 - ◆ *To remove the wiper blades, the wiper arms should be placed in the "service/winter position". The "service/winter position" is activated within 10 seconds after ignition is switched off by pressing windscreen wiper lever in "tip wipe".*
- Place wiper arm in "service/winter position" by operating the windscreen wiper lever within 10 seconds after ignition is switched off in "tip wipe" position.
 - Lift up wiper arm.



- Turn wiper blade -1- on wiper arm onto limit stop -arrow A-.
- Pull wiper blade -1- off axis of wiper arm -arrow B-.

Installing:

- Slide wiper blade onto axis of wiper arm.
- Turn wiper blade on axis of wiper arm onto stop.
- Carefully fold wiper arm back down onto windscreen.

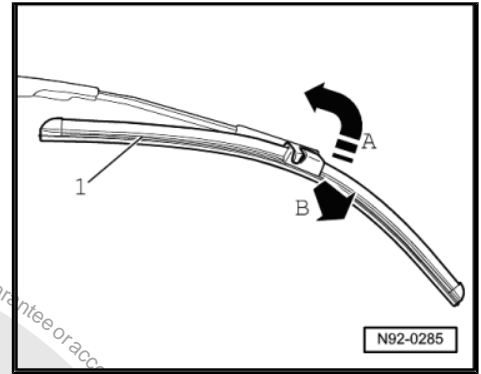

1.6 Removing and installing rain and light detector sensor -G397-

Removing:

Special tools and workshop equipment required

- ◆ Removal wedge -3409-

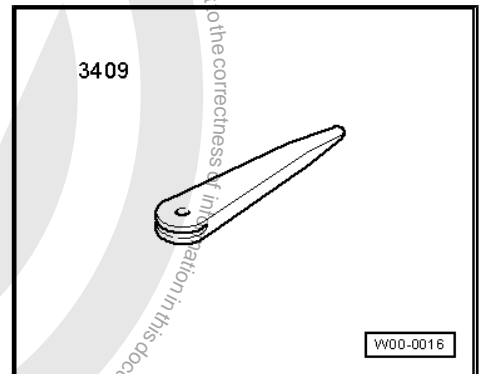

- Switch off ignition and all electrical consumers and pull out ignition key.
- Remove interior mirror ⇒ General body repairs, interior; Rep Gr. 68 ; Removing and installing interior mirror .
- Pull connector -1- off rain and light detector sensor -G397-2-.





- Using removal wedge -3409- , lever rain and light detector sensor -G397- -1- out of retainer -2-.



Note

When removing, ensure to remove the complete rain and light detector sensor -G397- and not only the upper shell of the sensor.

Installing:

Installation is performed in the reverse order of installation; when doing this, note the following:



Note

- ◆ *Before installing, thoroughly clean the windscreen, within the retainer for the rain and light detector sensor -G397- .*
- ◆ *The surface (coupling cushions) of the rain and light detector sensor -G397- must not be soiled when installing.*
- ◆ *If the surface (coupling cushions) of the rain and light detector sensor -G397- is soiled, it can possibly be cleaned by "Applying" and "Pulling off" one or more tapes.*
- ◆ *After installing the rain and light detector sensor -G397- there must be no air bubbles between windscreen and the surface (coupling cushions).*

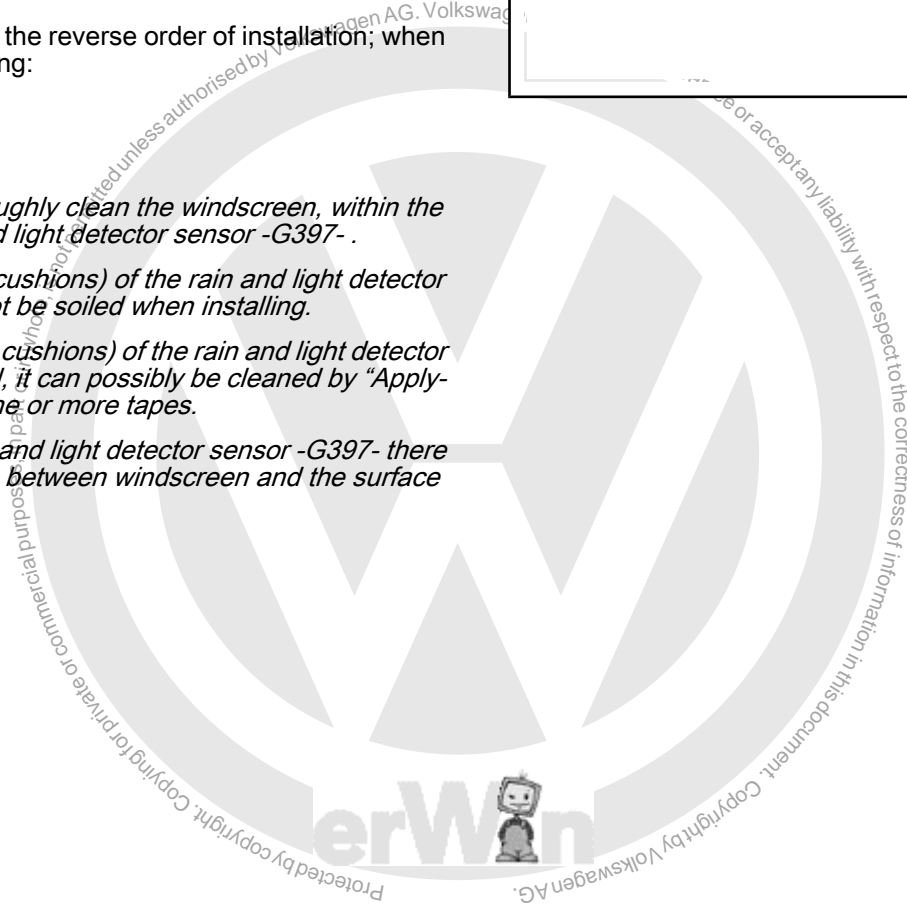
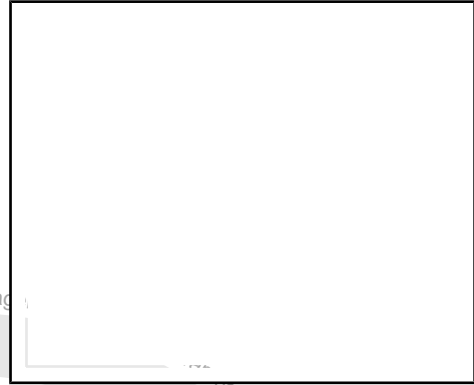



2 Windscreen washer system



Note

Additional information:

⇒ Operating instructions

2.1 Assembly overview of windscreen washer system

1 - Y-piece

- Distribution of wash water line to windscreen spray jets

2 - Spray jet for windscreen washer system, right

- Removing and installing ⇒ [page 169](#)
- Adjusting ⇒ [page 169](#)

3 - Spray jet for windscreen washer system, left

- Removing and installing ⇒ [page 169](#)
- Adjusting ⇒ [page 169](#)

4 - Elbow

- Connection to left windscreen spray jet
- Overview of washer water line hose couplings ⇒ [page 174](#)

5 - Hose

- Hose repair ⇒ [page 176](#)

6 - Elbow

- Connection to right windscreen spray jet
- Overview of washer water line hose couplings ⇒ [page 174](#)

7 - Filler pipe for reservoir for windscreen washer and headlight washer systems

- Removing and installing ⇒ [page 166](#)

8 - Washer pump -V5-

- Removing and installing ⇒ [page 168](#)

9 - Windscreen washer system and headlight washer system reservoir

- Removing and installing ⇒ [page 167](#)

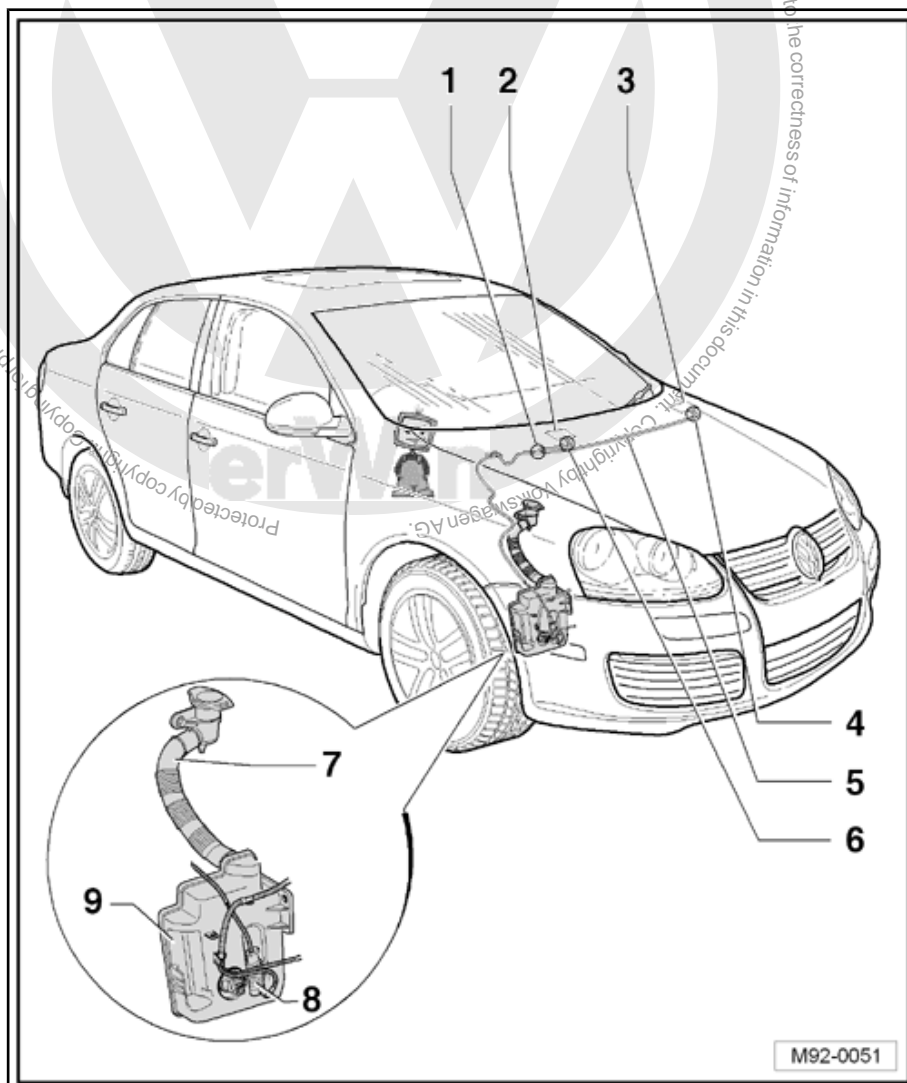

M92-0051



2.2 Removing and installing reservoir for windscreen and headlight washer systems

The reservoir for windscreen and headlight washer systems has three parts. The individual parts are connected together. To ensure a correct positioning of the individual parts, observe that the guides of the individual parts run in one another when installing.

1 - Removing and installing filler pipe for windscreen and headlight washer system reservoir => [page 166](#)

2 - Connecting pipe filler neck/reservoir; the connecting pipe is removed together with the reservoir for windscreen washer and headlight washer systems => [page 167](#)

3 - Removing and installing reservoir for windscreen and headlight washer systems => [page 167](#)

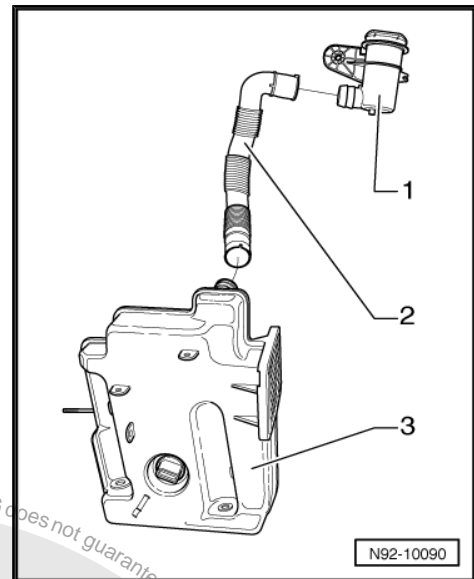

2.2.1 Removing and installing filler pipe for windscreen and headlight washer system reservoir

Removing:

- Pull filler pipe -1- off union -3- on reservoir for windscreen and headlight washer systems.
- Remove securing bolt -2-.
- Unclip hose retainer from filler neck -3- and take it out of the vehicle.

Installing:

Installation is carried out in the reverse order. When installing, note the following:

The funnel on the underside of the filler pipe should be inserted in the hole -arrow-.

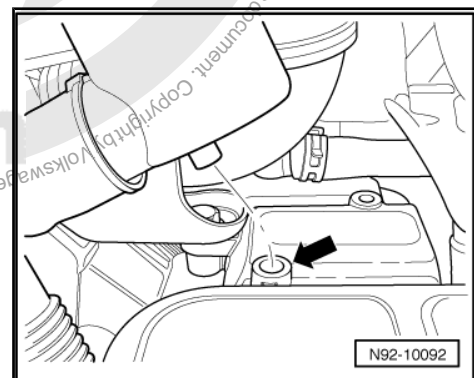
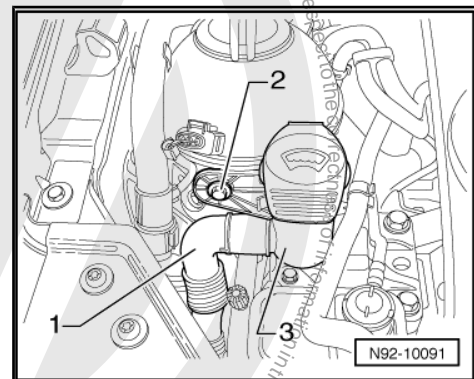



Connecting pipe -1- and filler neck -2- must be fitted together so that the guides -arrows- grip into one another.

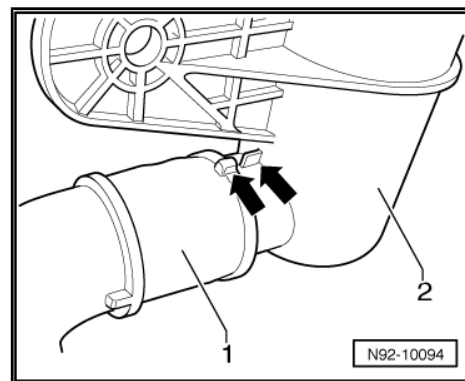

2.2.2 Removing and installing reservoir for windscreen and headlight washer systems

Removing:

- Switch off ignition and all electrical consumers and pull out ignition key.
- Remove filler pipe for windscreen and headlight washer system reservoir => [page 166](#) .
- Remove front bumper cover => Body Repairs, exterior; Rep. Gr. 63 ; Front bumper .



Note

The connections to the pump and hose lines are colour-coded in order to prevent the washer water lines being incorrectly connected to the front and rear washer water pump -V5-. The hose fittings must be inserted into the correct colour-coded pump connections during assembly.

- To unlock, turn the securing clips hose connections -3- and -5- and pull them out of the windscreen washer pump -V5- -4-.
- If necessary, collect washer fluid that leaks out with a suitable container.
- Separate the connector -6- of windscreen washer fluid level sender -7-.
- Take washer pump -V5- -4- upwards out of reservoir and separate connector -2-.
- Pull headlight washer system pump -V11- -9- upwards out of reservoir and separate connector and separate connector -10-.

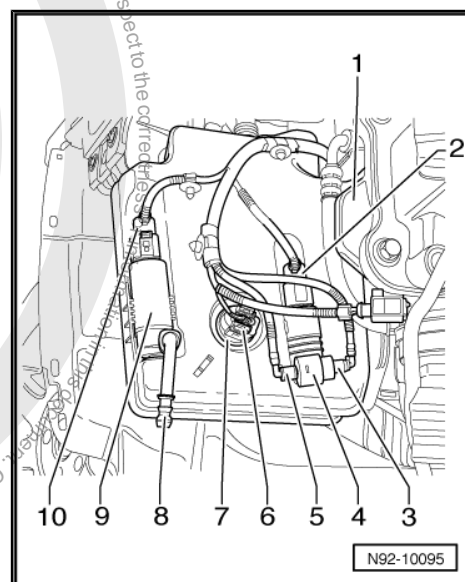



- Unbolt securing bolts -arrows- and take reservoir out of vehicle.

Installing:

Installation is carried out in the reverse order. When installing, note the following:

- Tighten threaded connections to specified torque settings ⇒ [page 178](#) .
- Bleed the headlight washer system after completing work ⇒ [page 173](#) .

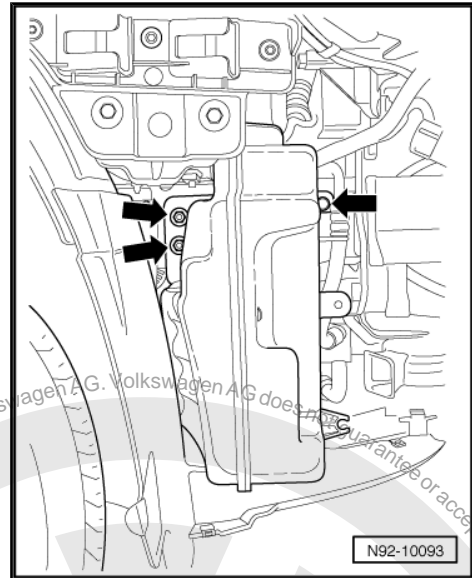

2.3 Removing and installing washer pump - V5-

Removing:

- Switch off ignition and all electrical consumers and pull out ignition key.
- Remove front bumper cover ⇒ Body Repairs, exterior; Rep. Gr. 63 ; Front bumper .



Note

The connections to the pump and hose lines are colour-coded in order to prevent the washer water lines being incorrectly connected to the front and rear windscreen and rear window washer pump -V59- . The hose fittings must be inserted into the correct colour-coded pump connections during assembly.

- To unlock, turn the securing clips hose connections -3- and -5- and pull them out of the windscreen washer pump -V5- -4-.
- If necessary, collect fluid leaking out with a suitable container.
- Pull washer pump -V5- -4- upwards out of the reservoir.
- Disconnect connector -2-.

Installing:

Installation is carried out in the reverse order. When installing, note the following:

- Tighten threaded connections to specified torque settings ⇒ [page 178](#) .
- Bleed the headlight washer system after completing work ⇒ [page 173](#) .

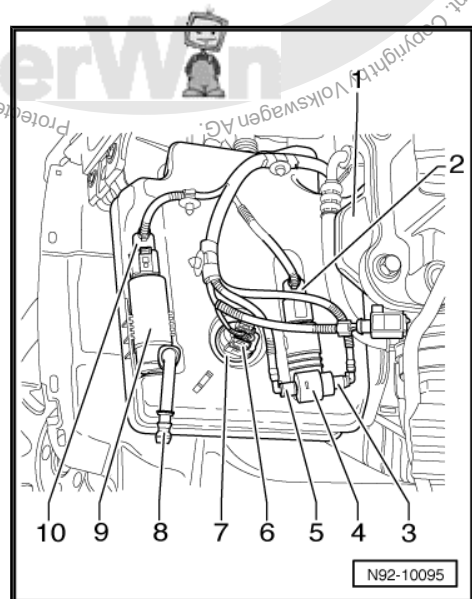



2.4 Removing and installing windscreen washer spray jets

Removing:

- Push spray jets upwards -arrow A- and pull out of bonnet from rear -arrow B-.

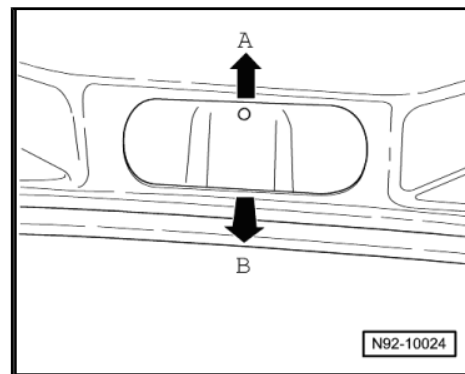

- Pull hose -1- off spray jet and disconnect connector -2-.

Installing:

- Fit connector -2- and hose -1- on spray jet.
- Push spray jet in installation hole until it is heard to lock in place.
- Adjust spray jets ⇒ [page 169](#) .

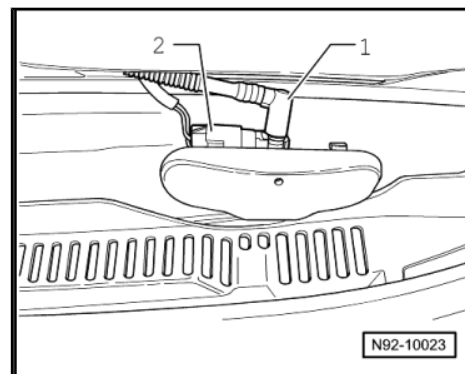

2.5 Adjusting front windscreen washer system spray jets



Note

If the spray field is not uniform because the spray jet is soiled, remove the spray jet and clean in opposite direction of spray with water. In the following it is allowed to blow the spray jets in opposite direction of spray with compressed air. Do not use objects to clean the spray jets.

Maintenance ; Booklet 20.1



3 Headlight washer system



Note

Additional information:

⇒ Current flow diagrams, Electrical fault finding and Fitting locations

⇒ Operating instructions

General description:

Every fifth time the front windscreen washer system is activated the headlights are also washed if the windscreen wiper lever on the steering wheel is pulled for at least 1.5 seconds - provided either dipped beam or high beam are switched on.

The “active time” of the headlight washer system can be variably adjusted to between 0 and 12.75 seconds ⇒ [page 294](#) .

To guarantee sound functioning, the headlight washer system must be vented following assembly work or when activated for the first time ⇒ [page 173](#) .

Fault detection and fault display:

The onboard supply control unit -J519- is equipped with self-diagnosis, which is designed to ease fault finding.

For fault finding, use the vehicle diagnosis, testing and information system -VAS 5051A- in “guided fault finding” mode.





3.1 Assembly overview - headlight washer system

1 - Washer spray jet assembly with right spray jets

- Removing and installing spray jet assembly ⇒ [page 173](#)
- Adjusting spray jets ⇒ [page 173](#)
- Removing and installing pop-up spray jet cylinder ⇒ [page 172](#)

2 - Washer spray jet assembly with left spray jets

- Removing and installing spray jet assembly ⇒ [page 173](#)
- Adjusting spray jets ⇒ [page 173](#)
- Removing and installing pop-up spray jet cylinder ⇒ [page 172](#)

3 - Elbow

- Connection to left spray jet pop-up cylinder
- Overview of washer water line hose couplings ⇒ [page 174](#)

4 - Hose

5 - Elbow

- Connection to right spray jet pop-up cylinder
- Distribution of washer water to spray jets on headlight washer system

- Overview of washer water line hose couplings ⇒ [page 174](#)

6 - T-piece

- Distribution of washer water to spray jets on headlight washer system

7 - Elbow

8 - Headlight washer system pump -V11-

- Removing and installing ⇒ [page 171](#)

9 - Windscreen washer system and headlight washer system reservoir

- Removing and installing ⇒ [page 166](#)

10 - Filler pipe for reservoir for windscreen washer and headlight washer systems

- Removing and installing ⇒ [page 166](#)

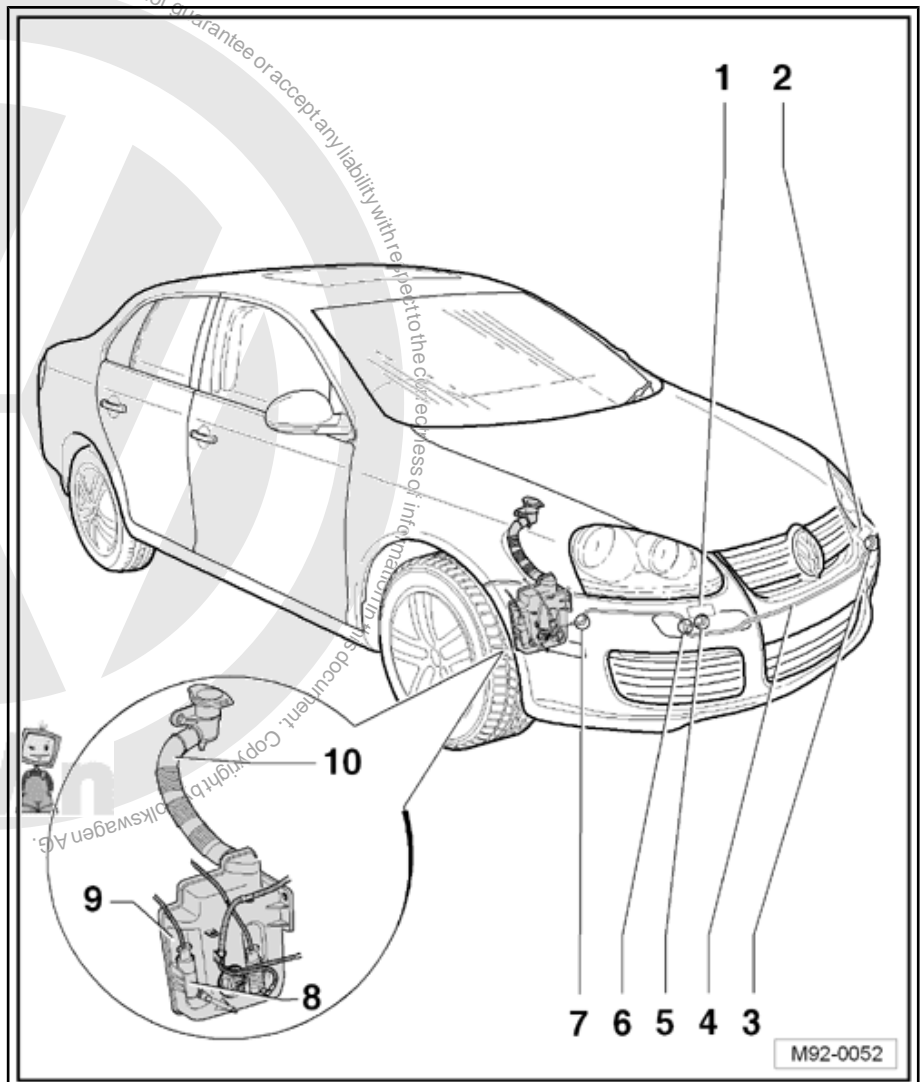

3.2 Removing and installing headlight washer system pump -V11-

The headlight washer system pump -V11- is fitted on the windscreen and headlight washer system in the right housing liner.



Removing:

- Switch off ignition and all electrical consumers and pull out ignition key.
- Remove front bumper cover ⇒ Body Repairs, exterior; Rep. Gr. 63 ; Front bumper .
- Pull headlight washer system pump -V11- -9- upwards out of the reservoir.
- Disconnect connector -10-.
- To remove the connecting pipe -8- pull securing clip on connection and pull connecting pipe -8- off headlight washer system pump -V11- .

Installing:

Installation is carried out in the reverse order. When installing, note the following:

- Tighten threaded connections to specified torque settings ⇒ [page 178](#) .
- Bleed the headlight washer system after completing work ⇒ [page 173](#) .

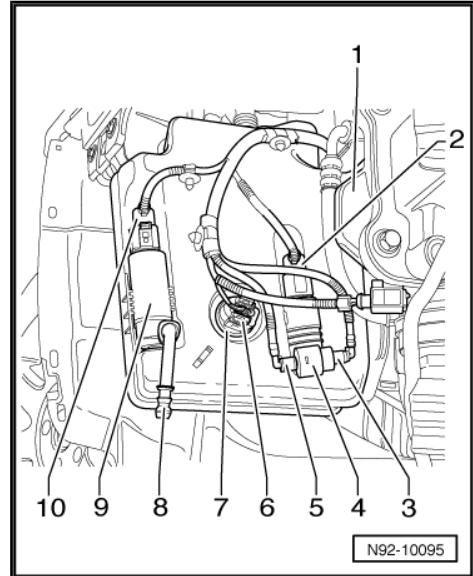

3.3 Removing and installing pop-up spray jet cylinder

Removing:

- Switch off ignition and all electrical consumers and pull out ignition key.
- Pull spray jets with cap -1- out of bumper cover onto stop.
- Unclip cap -1- from mounting points -arrows- on washer spray jet assembly.
- Remove front bumper cover ⇒ Body Repairs, exterior; Rep. Gr. 63 ; Front bumper .
- Pull the securing clip -4- off hose connection.
- Pull hose connection off pop-up cylinder -2-.
- Remove securing bolt -1-.
- Unclip pop-up spray jet cylinder -2- from bracket -3-.

Installing:

Installation is carried out in the reverse order. When installing, note the following:

- The pop-up spray jet cylinder hose must be attached to the securing clip on the bracket.
- Tighten threaded connections to specified torque settings ⇒ [page 178](#) .
- Bleed the headlight washer system after completing work ⇒ [page 173](#) .

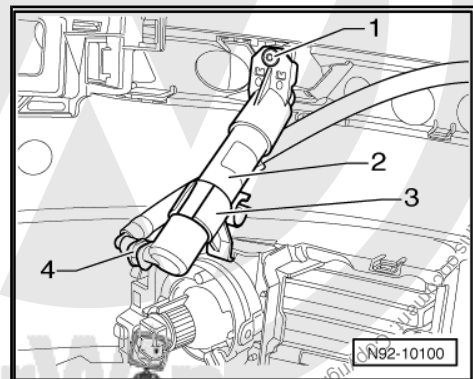
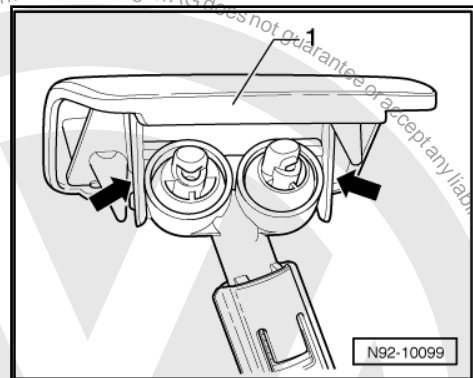



3.4 Removing and installing spray jet assembly

Removing:

- Switch off ignition and all electrical consumers and pull out ignition key.
- Pull spray jet with cover cap -1- onto stop out of bumper cover.
- Unclip cap -1- from mounting points -arrows- on washer spray jet assembly.

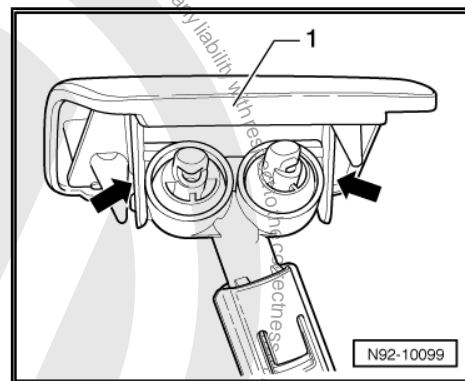

- Lever locking hooks -arrow- up slightly and pull out spray jet assembly.

Installing:



Note

The degree to which the cover cap of the spray jet is pulled down onto the bumper cover can be adjusted using the clips on the washer spray jet assembly. If the washer spray jet assembly is not pulled in far enough, the cover cap will not seat correctly. If the washer spray jet assembly is pulled in too far, the cover cap and the bumper cover could be pushed out of shape.

- Push washer spray jet assembly in pop-up cylinder until it engages.
- Fit cover cap on washer spray jet assembly and allow pop-up cylinder to retract.
- Check the cover cap is seated correctly on the bumper cover.
- If necessary, adjust seat of cover cap by pushing washer spray jet assembly in higher or lower position on pop-up cylinder.
- Bleed the headlight washer system after completing work ⇒ [page 173](#) .
- Check headlight washer system spray jets and adjust if necessary ⇒ [page 173](#) .

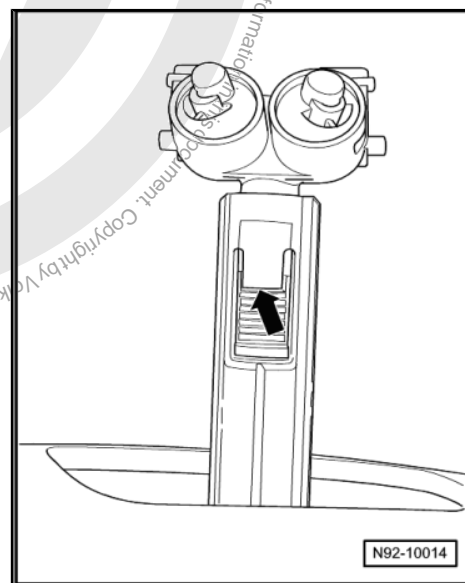

3.5 Adjusting headlight washer system jets

⇒ Maintenance ; Booklet 18.1

3.6 Bleeding the headlight washer system

To guarantee sound functioning, the headlight washer system must be bled following assembly work or when operated for the first time.

- Fill reservoir for windscreen and headlight washer systems.
- Start the engine.
- Switch "ON" the headlight.
- Operate headlight washer system several times (3-5 times, 3 seconds each time).
- Repeat this bleeding procedure until the pop-up cylinders and spray jets are functioning soundly.



4 Wash water line hose couplings

The following hose coupling types are used to connect the hoses to pumps and spray jets and/or as points of separation:

4.1 Windscreen and rear window washer system

- Pull the two coupling sections apart (no securing device) to loosen the connection.
- To secure the connection, push the two coupling sections together, until you hear and feel them engage.

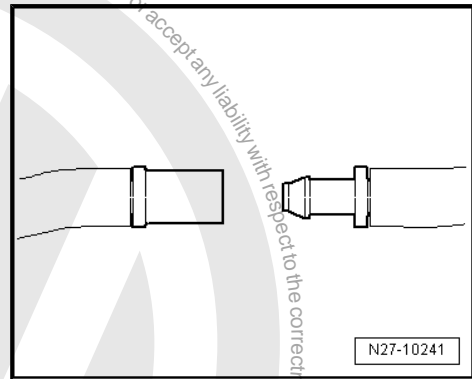

- To loosen the connection, rotate the lock ring -1- by 90° -arrow- and pull off the hose connection.
- To secure the connection, push on the hose connection and rotate the lock ring -1- -arrow- until it engages.

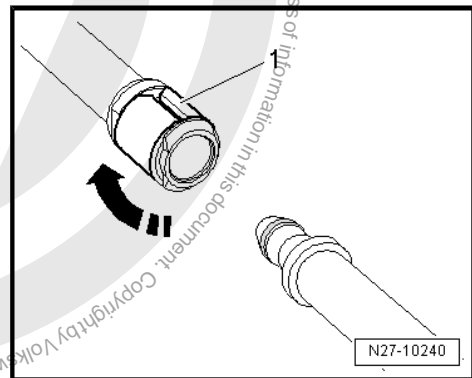

- To loosen the connection, pull up the lock ring -1- by approx. 1 mm -arrow- and pull off the hose connection.
- To secure the connection, push on the hose connection and push in the lock ring -1- until it engages.

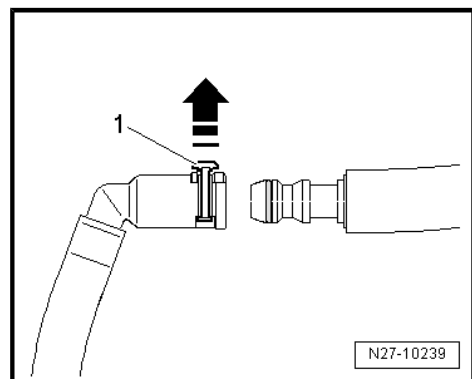



4.2 Headlight washer system

- To loosen the connection -1- push the lock ring -arrow- and pull off the hose connection.
- To secure the connection, push and hold the lock ring -arrow- and push on the hose connection. Check that the securing clip has correctly engaged by depressing and trying to pull off without the clip.

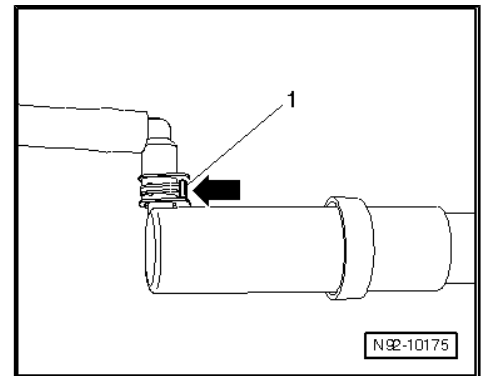



5 Hose repair

A new repair concept has been developed for repair work on wash system hoses. Various connectors, special EPDM hoses (ethylene propylene diene monomer) and heat-shrink hose are available as spare parts

5.1 General description

- ◆ The replacement parts can be found in the parts catalogue (ETKA).
- ◆ Replacement parts are available for repair of both smooth and corrugated pipes.

5.2 Repairing smooth pipe

Smooth pipe with a diameter of 5x1 mm or 6x1 mm can be repaired with EPDM hose.

- Cut damaged section at right angles out of smooth pipe which is to be repaired.
- Select the appropriate EPDM hose -2- and cable ties according to the parts catalogue (ETKA).
- Cut EPDM hose -2- so that ends -1- and -3- of smooth pipe can each be pushed about 10 mm into the EPDM hose -2-.
- Secure the repair joints with cable ties -1-.

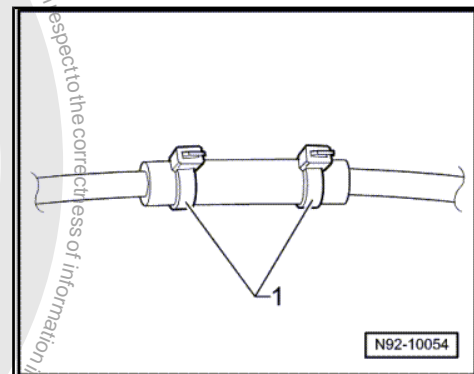
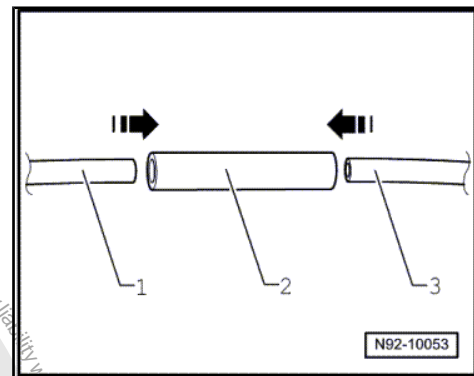

5.3 Repairing corrugated pipe

Special tools and workshop equipment required

- ◆ Hot air gun -VAS 5179- or

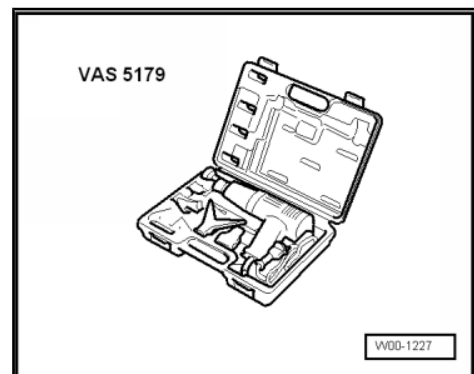

- ◆ Hot air gun -V.A.G 1416/- or
- ◆ Hot air blower -VAS 1978/14-



Note

- ◆ *Repair points must not be subjected to pulling or bending forces.*
- ◆ *If the damaged section is longer than 20 mm, a new piece of corrugated pipe must be used and the procedure described below must be performed twice.*

- Cut damaged section at right angles out of corrugated pipe which is to be repaired.
- Select the appropriate connectors -2- and -3- as well as the appropriate heat-shrink hose according to the parts catalogue (ETKA).
- Heat end of corrugated pipe -1-.
- Push connector -2- into corrugated pipe -2- -arrow A-.
- Heat end of corrugated pipe -4-.
- Push connector -3- into corrugated pipe -4- -arrow B-.
- Cut heat-shrink hose so that ends of corrugated pipe are each covered by about 20 mm -dimension x- of heat-shrink hose.
- Push heat-shrink hose over corrugated pipe, join connectors and secure repair joints with heat-shrink hose.

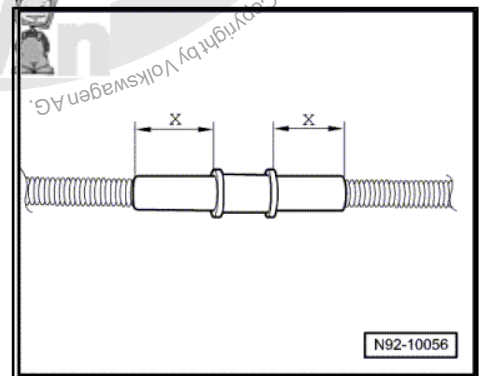
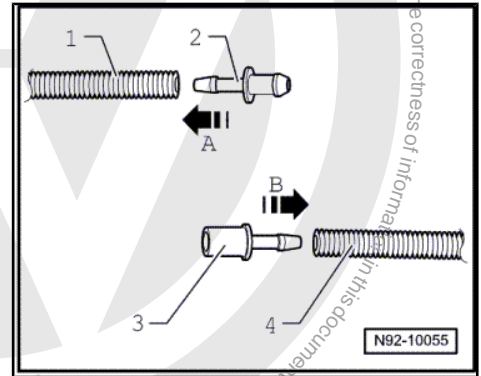



6 Torque settings: Windscreen wash/wipe system

Threaded connections		Torque settings
Wiper motor to wiper frame	M6	8 Nm
Motor crank arm to wiper motor shaft	M8	18 Nm
Wiper frame to body	M6	8 Nm
Windscreen wiper arms to wiper motor shaft	M8	20 Nm
Windscreen washer system and headlight washer system reservoir	M6	8 Nm
Pop-up spray jet cylinder front bumper cover		4.5 Nm





94 – Lights, lamps, switches - outside

1 Headlight



Note

- ◆ *Before working on headlights, always switch off the headlights and remove the ignition key.*
- ◆ *When dealing with complaints, it is absolutely essential that the function and operation of the lighting system is first understood.*
- ◆ *Additional information:*

⇒ Operating instructions

In the vehicle there are fitted headlights of three different manufacturers:

- ◆ AL (Automotive Lighting)
- ◆ Hella

Removal and installation of the headlights and its attachments is the same, only the removing and installing of the actuator motors are different.

Fault detection and fault display:

The onboard supply control unit has a self-diagnosis function, which makes fault finding on the headlights easier.

For fault finding, use the vehicle diagnosis, testing and information system -VAS 5051A- in "guided fault finding" mode.

1.1 Assembly overview, Headlight



Note

In the overview there are shown the three control motors of the different headlight manufacturers because their removal and installation is different.





1 - Securing bolts

- 4 Nm

2 - Adjustment bushes

- Correcting installation position of headlight
⇒ [page 182](#)

3 - Left headlight main beam bulb -M30- or right headlight main beam bulb -M32-

- Bulb H7U 12 V, 55 W
- Renewing ⇒ [page 185](#)

4 - Left side light bulb -M1- or right side light bulb -M3-

- Bulb 12 V, W 5 W
- Renewing ⇒ [page 187](#)

5 - Cover cap

6 - Front left turn signal bulb -M5- or front right turn signal bulb -M7-

- Bulb 12 V, PY 21 W
- Renewing ⇒ [page 188](#)

7 - Bulb holder with grip element

- For front left turn signal bulb -M5- or front right turn signal bulb -M7-

8 - Body section

9 - Cover cap

10 - Bulb holder with grip element

- For left headlight dipped beam bulb -M29- or right headlight dipped beam bulb -M31-

11 - Left headlight dipped beam bulb -M29- or right headlight dipped beam bulb -M31-

- Bulb H7 12 V, 55 W
- Renewing ⇒ [page 184](#)

12 - Headlights

- Removing and installing ⇒ [page 181](#)
- Correcting installation position of headlight ⇒ [page 182](#)
- Servicing headlight securing lugs ⇒ [page 188](#)

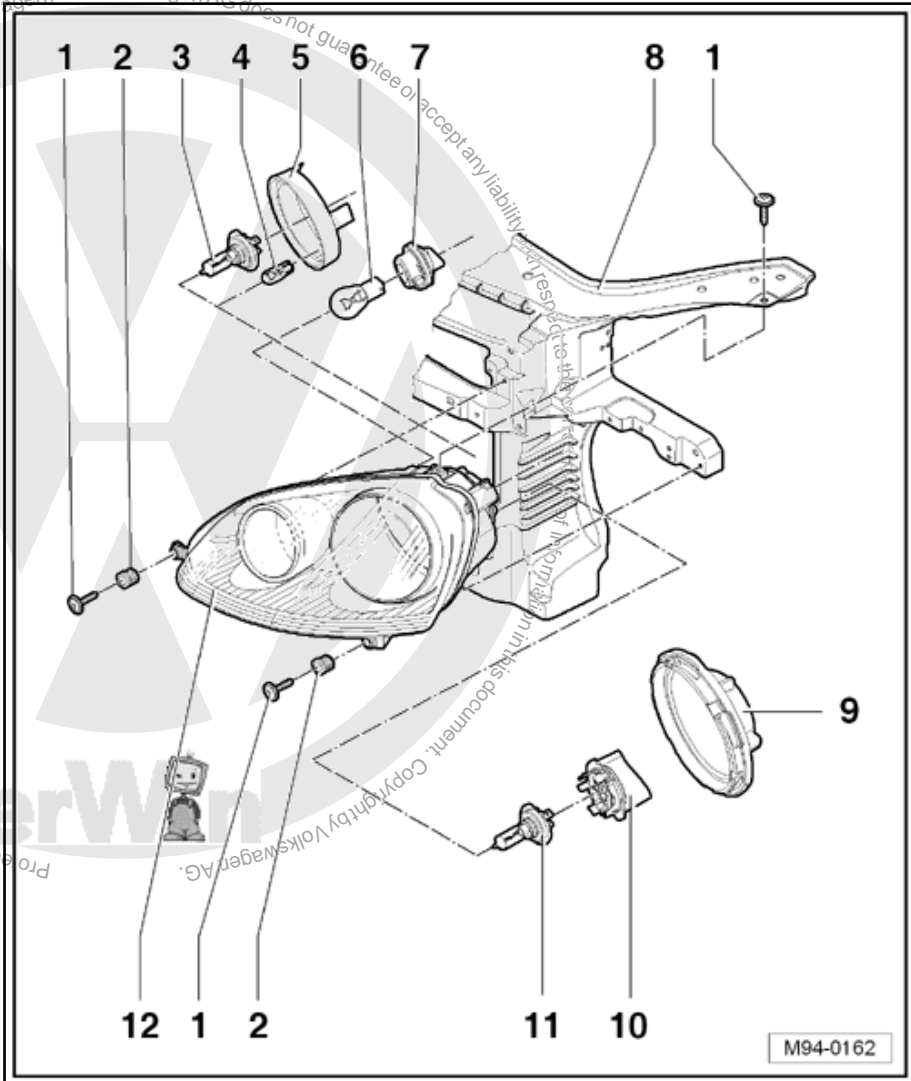



1.2 Removing and installing headlights

1.2.1 Removing headlights



Note

- ◆ *It is not necessary to disconnect the battery earth strap.*
 - ◆ *The diagrams show how the left headlight is removed and installed.*
 - ◆ *If a headlight is removed, it should always be adjusted ⇒ Maintenance ; Booklet 20.1 .*
 - ◆ *If a headlight with gas discharge lamps is removed, a basic setting must be performed to adjust the headlights ⇒ Maintenance ; Booklet 20.1 .*
- Switch off ignition and all electrical consumers and pull out ignition key.
 - Release multi-pin connector -arrow- and pull off multi-pin connector.
 - Remove front bumper ⇒ General body repairs; Rep. Gr. 63 ; Front bumper

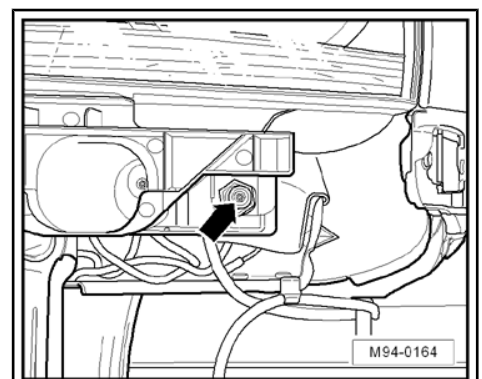
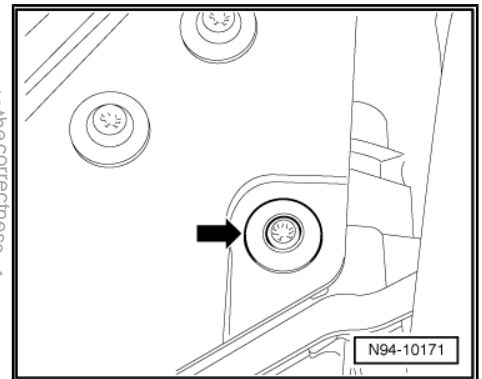
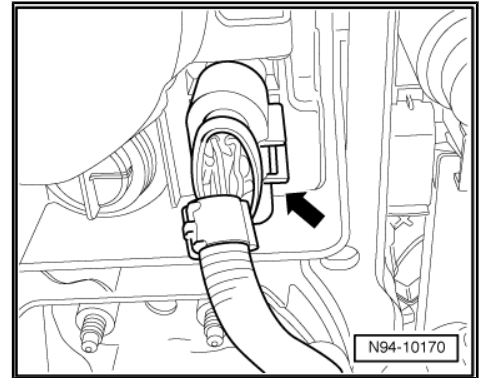

- Unscrew securing screw -arrow- on upper headlight.

Unscrew securing screw -arrow- on lower left headlight.





- Unscrew securing screw -arrow- on lower right headlight.

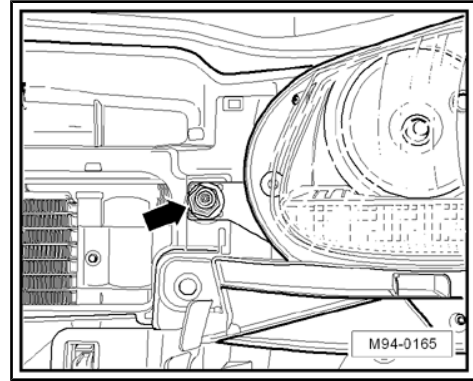

1.2.2 Installing headlights

Installation is performed in the reverse order of installation; when doing this, note the following:

- Tighten all securing bolts to specified torque setting
⇒ [page 238](#) .
- Check headlight installation position is central, i.e. shutlines are equal around headlight.

If the shutlines around the headlight are uneven, the installation position must be adjusted ⇒ [page 182](#) .

- Check function of headlight.



Note

If a headlight is removed, it should always be adjusted.

- Check headlight setting and adjust headlight as necessary
Maintenance ; Booklet 20.1

1.3 Adjusting headlight installation position



Note

- ◆ *To adjust the headlight installation position, the front bumper must not be removed.*
- ◆ *The diagrams show the left headlight.*

If it transpires during checking of the installation position that the shutlines between headlight and body are uneven, the installation position must be adjusted.

- Switch off ignition and all electrical consumers and pull out ignition key.
- Remove radiator ⇒ General Body Repairs, Exterior; Rep. Gr. 66 ; Strips and trim .



- Unscrew securing screw -arrow- on upper headlight.

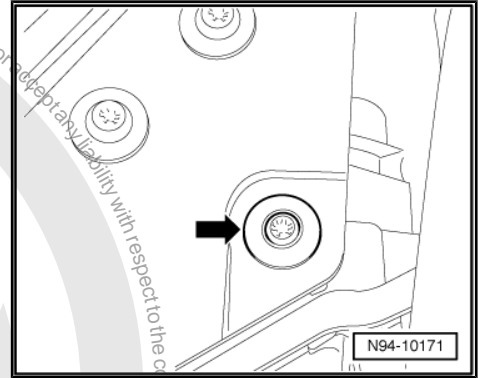

- Unscrew securing screw -arrow- on lower left headlight.

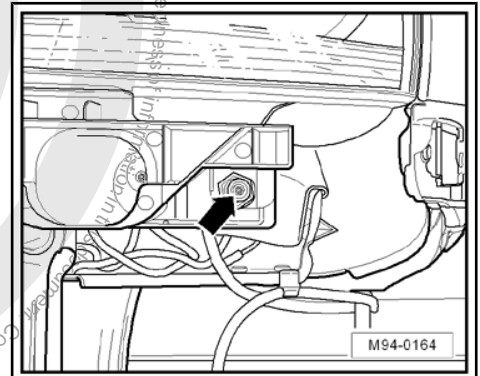

- Unscrew securing screw -arrow- on lower right headlight.

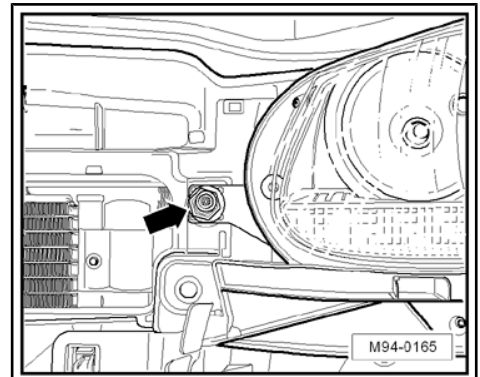

- Adjust shutlines to body by pushing in or pulling out alignment bush -arrow- on lower left or lower right headlight.
- Tighten threaded connections to specified torque settings
 => [page 238](#) .
- Check and, if necessary, readjust headlight to ensure gaps are even all round.
- Install radiator => General Body Repairs, Exterior; Rep. Gr. 66 ; Strips and trim; Removing and installing radiator .
- Check function of headlight.

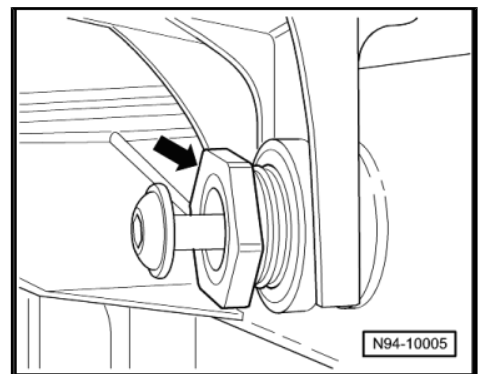

i Note

If a headlight is removed or adapted to the body it should always be adjusted after installing or adapting it.

- Check headlight setting and adjust headlight as necessary
 => Maintenance ; Booklet 20.1



1.4 Renewing headlight bulbs

1.4.1 Renewing dipped beam headlight bulb



Note

The diagrams show renewal of the dipped beam headlight bulb for the left headlight.

Removing:

- Switch off ignition and all electrical consumers and pull out ignition key.
- Turn cover cap -1- in -direction of arrow- and remove.

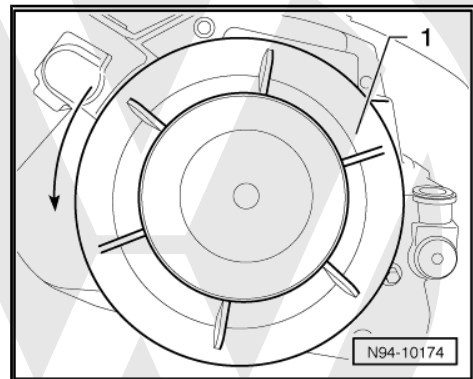

- Turn bulb holder with dipped beam headlight bulb -1- in -direction of arrow- and remove from headlight.

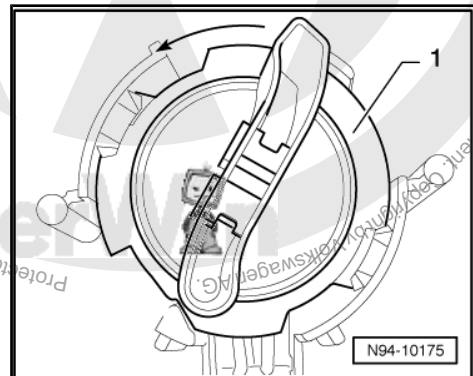

- Pull dipped beam headlight bulb -2- in -direction of arrow- out of bulb holder -1-.

Installing:



Note

- ◆ When installing cap, ensure that it is seated correctly. The ingress of water will lead to permanent damage of the headlight.
- ◆ Do not touch bulb glass when fitting bulbs. Fingers leave traces of grease on the glass, which evaporate when the bulb is switched on and cause the glass to cloud over.

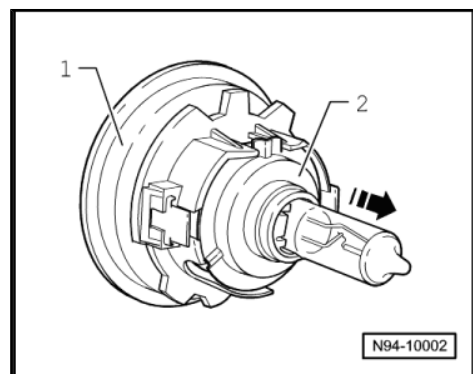



- Place headlight dipped beam bulb -1- in the bulb holder that the pin on the dipped beam headlight bulb lies in the recess -arrow- of bulb holder -2-.

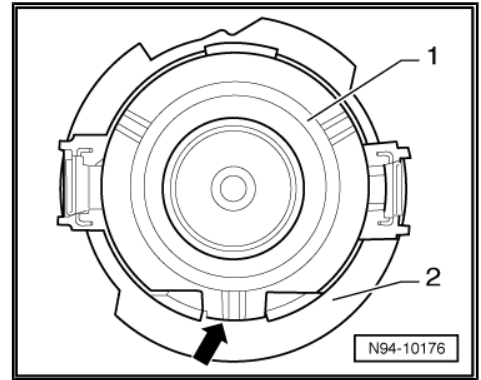

- Place bulb holder with dipped beam headlight bulb -1- in headlight and turn bulb holder with dipped beam headlight bulb in -direction of arrow-.

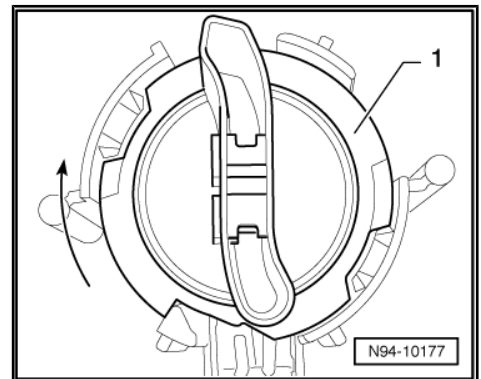

- Place cover cap -1- in headlight recess, and tighten in -direction of arrow-.
- Check function of headlight.
- Check headlight setting and adjust headlight as necessary
=> Maintenance ; Booklet 20.1

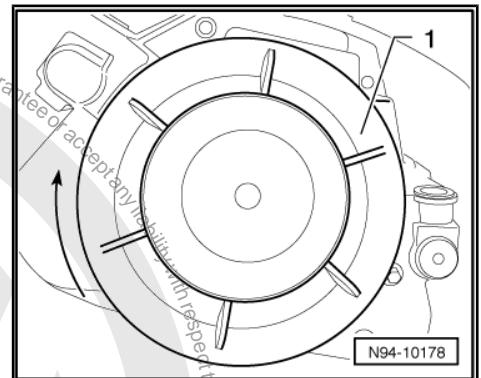

1.4.2 Renewing main beam headlight bulb



Note

The diagrams show renewal of the main beam headlight bulb for the left headlight.

Removing:

- Switch off ignition and all electrical consumers and pull out ignition key.



- Pull off cover cap -1-.

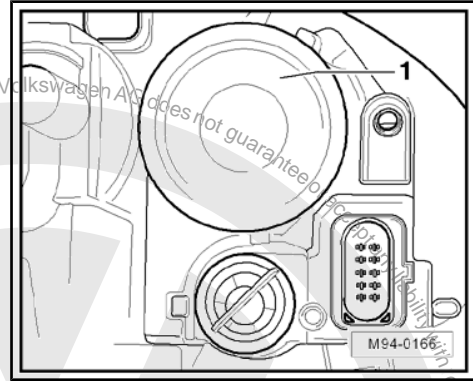

- Pull off multi-pin connector -2-.

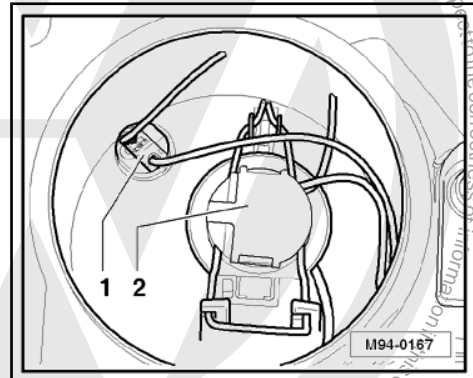

- Press spring retaining clip -2- in -direction of arrow- under the locking lugs-1- and fold spring retaining clip -2- upwards.

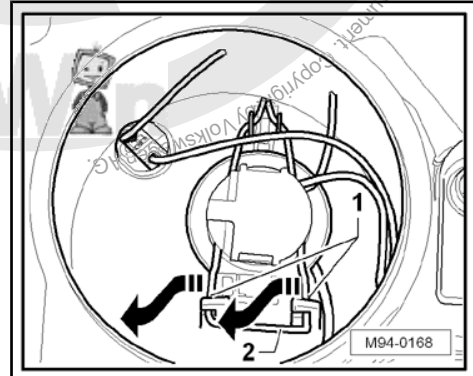

- Take headlight main beam bulb -1- out of the headlight.

Installing:



Note

- ◆ *When installing cap, ensure that it is seated correctly. The ingress of water will lead to permanent damage of the headlight.*
- ◆ *Do not touch bulb glass when fitting bulbs. Fingers leave traces of grease on the glass, which evaporate when the bulb is switched on and cause the glass to cloud over.*

Installation is performed in the reverse order of installation; when doing this, note the following:

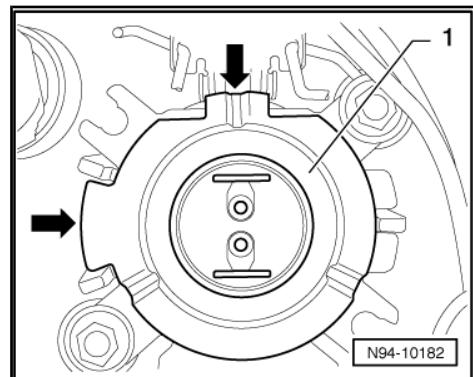



- Place the headlight main beam bulb -1- in the recesses -arrows- on the headlight.
- Check function of headlight.
- Check headlight setting and adjust headlight as necessary
⇒ Maintenance ; Booklet 20.1

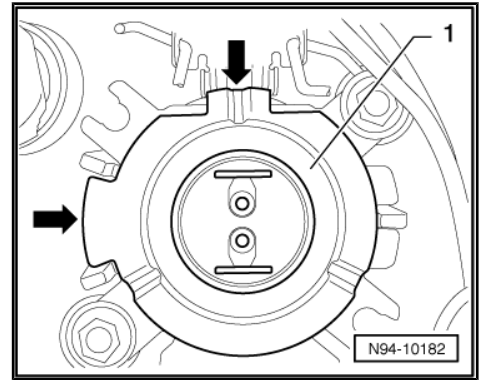

1.4.3 Renewing side light bulb

Note

The diagrams show renewal of the side light bulb for the left headlight.

Removing:

Switch off ignition and all electrical consumers and pull out ignition key.

Pull off cover cap -1-.

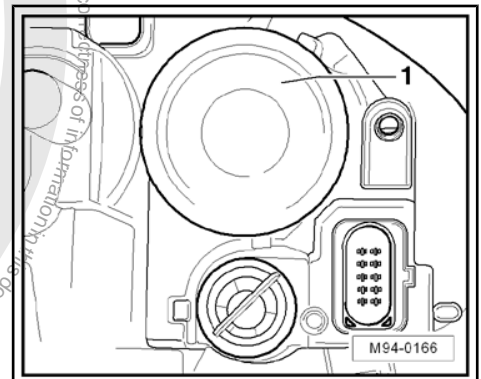

- Pull, depending on the cable length, the bulb holder -1- with the side light bulb as far it is possible out of the reflector.

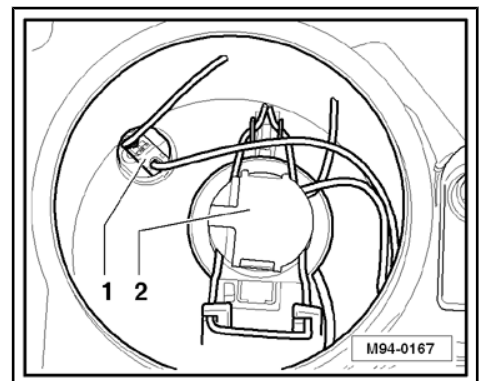



- Pull side light bulb -2- in -direction of arrow- out of the bulb holder -1-.

Installing:



Note

- ◆ *When installing cap, ensure that it is seated correctly. The ingress of water will lead to permanent damage of the headlight.*
- ◆ *Do not touch bulb glass when fitting bulbs. Fingers leave traces of grease on the glass, which evaporate when the bulb is switched on and cause the glass to cloud over.*

Installation is performed in the reverse order of installation; when doing this, note the following:

- Check function of headlight.
- Check headlight setting and adjust headlight as necessary
⇒ Maintenance ; Booklet 20.1

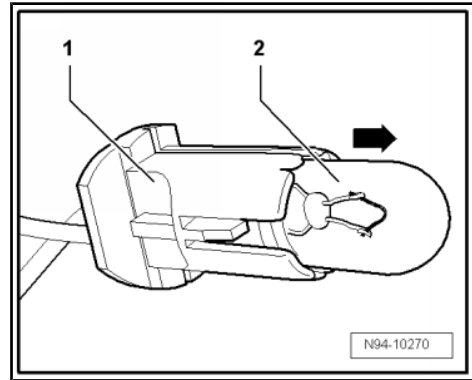

1.4.4 Renewing front turn signal bulb



Note

The diagrams show renewal of the turn signal bulb for the left headlight.

Removing:

- Switch off ignition and all electrical consumers and pull out ignition key.
- Turn bulb holder with front turn signal bulb -1- in direction of arrow and remove from headlight.
- Push front turn signal bulb into bulb holder, turn front turn signal bulb anti-clockwise and pull front turn signal bulb out of bulb holder.

Installing:



Note

- ◆ *When installing bulb holder, ensure that the seal is seated correctly. The ingress of water will lead to permanent damage of the headlight.*
- ◆ *Do not touch bulb glass when fitting bulbs. Fingers leave traces of grease on the glass, which evaporate when the bulb is switched on and cause the glass to cloud over.*

Installation is performed in the reverse order of installation; when doing this, note the following:

- Check function of headlight.
- Check headlight setting and adjust headlight as necessary
⇒ Maintenance ; Booklet 20.1

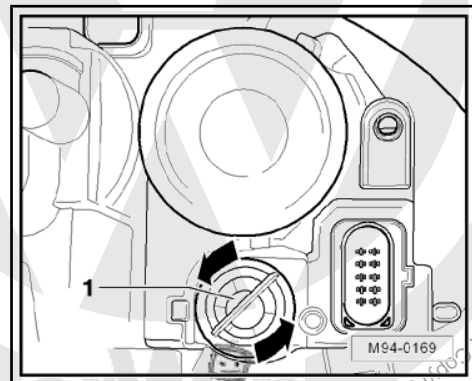

1.5 Servicing headlight securing lugs

Information on servicing headlight securing lugs was not available when it was time of going to press.



1.6 Adjusting headlights

Adjusting headlights ⇒ Maintenance ; Booklet 20.1 .





2 Main headlights with gas discharge bulbs



Note

- ◆ *Before working on gas discharge headlights, always switch off the headlights and remove the ignition key.*
- ◆ *The automatic headlight range control on headlights with gas discharge bulbs is equipped with self-diagnosis.*
- ◆ *When dealing with complaints, it is absolutely essential that the function and operation of the lighting system is first understood.*
- ◆ *Additional information:*

⇒ Operating instructions

⇒ Current flow diagrams, Electrical fault finding and Fitting locations

Fault detection and fault display:

The automatic headlight range adjustment (HRA) and onboard supply control unit have a self-diagnosis function, which makes fault finding on the headlights using gas discharge lamps easier.

For fault finding, use the vehicle diagnosis, testing and information system -VAS 5051A- in "guided fault finding" mode.



2.1 Assembly overview - gas discharge headlights



Note

After any measures which could affect the headlight setting, the headlight must be checked and if necessary adjusted ⇒ Maintenance ; Booklet 20.1 .

1 - Vent hose

- On headlight

2 - Left headlight range control motor -V48- or right headlight range control motor -V49-

- Headlight manufacturer: AL (Automotive Lighting)



Note

3 - Securing bolts

- For left headlight range control motor -V48- or right headlight range control motor -V49-

4 - Cover cap

5 - Gas discharge light starter unit -N195-

6 - Bulb locking

- For left gas discharge bulb -L13- or right gas discharge bulb -L14-

7 - Left gas discharge bulb -L13- or right gas discharge bulb -L14-

- Type D2S, 35W
- Renewing ⇒ [page 192](#)

8 - Securing bolt

- 4 Nm
- On upper headlight

9 - Headlights

- Removing and installing ⇒ [page 181](#)
- Correcting installation position of headlight ⇒ [page 182](#)
- Servicing headlight securing lugs ⇒ [page 204](#)

10 - Headlight range control unit -J431-

- Removing and installing ⇒ [page 198](#)
- Coding ⇒ [page 200](#)



Note

11 - Front left vehicle level sender -G78-

- Removing and installing ⇒ [page 201](#)
- Checking ⇒ [page 203](#) .

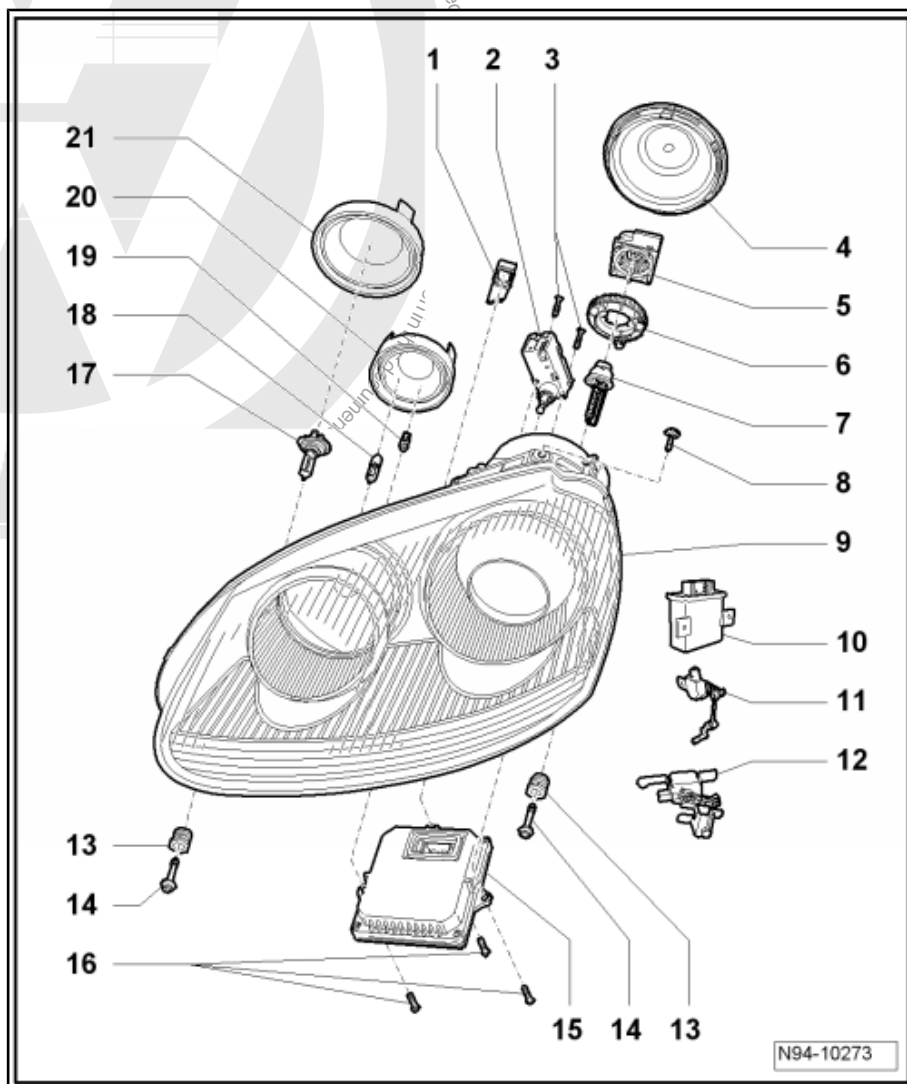



12 - Rear left vehicle level sender -G76-

- Removing and installing ⇒ [page 201](#)
- Checking ⇒ [page 203](#) .

13 - Adjustment bush

- Correcting installation position of headlight ⇒ [page 182](#)

14 - Securing bolt

- 4 Nm
- On lower headlight

15 - Left gas discharge light control unit -J343- or right gas discharge light control unit -J344-

- Not capable of self-diagnosis
- Removing and installing ⇒ [page 198](#)

16 - Securing bolts

- For left gas discharge light control unit -J343- or right gas discharge light control unit -J344-

17 - Left headlight main beam bulb -M30- or right headlight main beam bulb -M32-

- Bulb H7U 12 V, 55 W
- Renewing ⇒ [page 194](#)

18 - Front left turn signal bulb -M5- or front right turn signal bulb -M7-

- Bulb 12 V, H2 WLL 21 W
- Renewing ⇒ [page 197](#)

19 - Left side light bulb -M1- or right side light bulb -M3-

- Bulb 12 V, W 5 W
- Renewing ⇒ [page 196](#)

20 - Cover cap

- For front left turn signal bulb -M5- or front left turn signal bulb -M7- and for left side light bulb -M1- or right side light bulb -M3-

21 - Cover cap

- For left headlight main beam bulb -M30- or right headlight main beam bulb -M32-

2.2 Removing and installing headlights

Removing and installing headlights ⇒ [page 181](#) .

2.3 Adjusting headlight installation position

Adjusting headlight installation position ⇒ [page 182](#) .

2.4 Renewing headlight bulbs

2.4.1 Renewing gas discharge bulb



Note

The diagrams show renewal of a gas discharge bulb for the left headlight.

Removing:

- Remove headlight ⇒ [page 181](#) .



- Turn cover cap -1- in -direction of arrow- and remove.

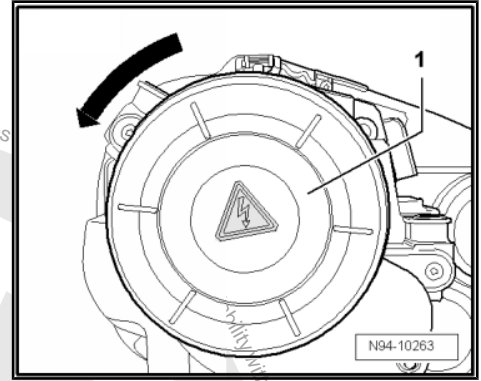

- Pull off connector -1-.



Note

The connector is ejected automatically when the gas discharge bulb starter unit -N195- is removed.

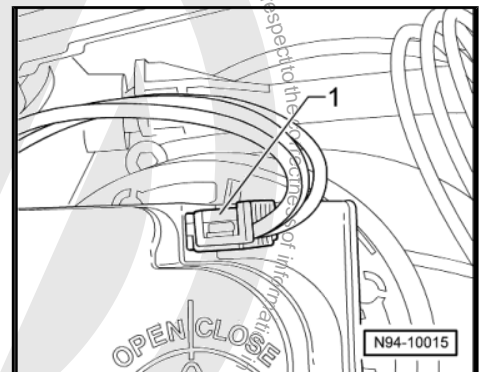

- Turn gas discharge bulb starter unit -N195- -1- in direction of starter unit lettering "OPEN" and pull gas discharge bulb starter unit -N195- off headlight.



WARNING

- ◆ *Within the bulb glass of gas discharge bulbs, pressures can range from between 7 bar (cold) and 100 bar (hot). Temperatures can reach up to 700 degrees Celsius on the glass bulb.*
- ◆ *The glass bulb may explode resulting in a risk of injury from burning.*
- ◆ *Always wear eye protection and gloves when removing and installing gas discharge bulbs!*

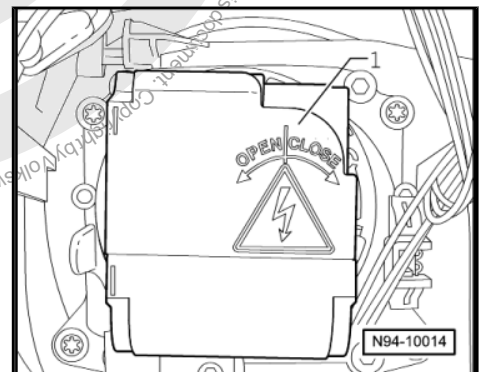

- Turn bulb retainer -1- in -direction of arrow- and remove bulb retainer.

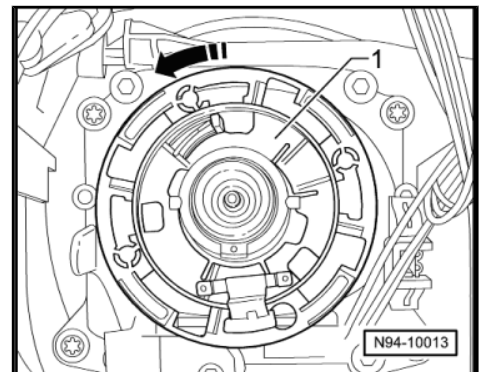



- Carefully pull gas discharge bulb -1- out of mounting.

Installing:



Note

- ◆ Do not touch bulb glass when fitting a gas discharge lamp bulb. Fingers leave traces of grease on the glass, which when switching the gas discharge lamp bulb on, evaporate and cause the glass to cloud over.
- ◆ Use extreme care when fitting a gas discharge lamp bulb and do not subject the bulb to mechanical stress. The glass bulb is extremely sensitive and is subjected to a very high pressure.
- ◆ Avoid looking directly into the collimated beam as the UV rays from the gas discharge bulb are about 2.5 times greater than normal halogen bulbs.
- ◆ When installing cap, ensure that it is seated correctly. The ingress of water will lead to permanent damage of the headlight.
- ◆ If a headlight is removed with automatic range control, the basic setting of the headlight should always be checked when reinstalling => Maintenance ; Booklet 20.1 .

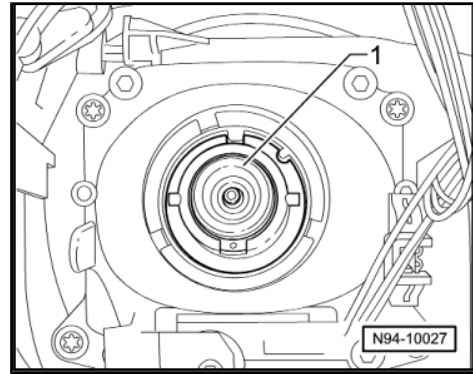

Installation is performed in the reverse order of installation; when doing this, note the following:

- Check function of headlight.
- Check headlight setting and adjust headlight as necessary
=> Maintenance ; Booklet 20.1

2.4.2 Renewing main beam headlight bulb



Note

The following diagrams show renewal of the main beam headlight bulb for the left headlight.

Removing:

- Switch off ignition and all electrical consumers and pull out ignition key.
- Pull off cover cap -1-.

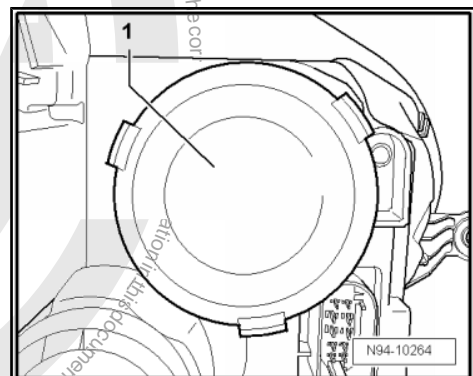



- Pull connector off -arrow-.

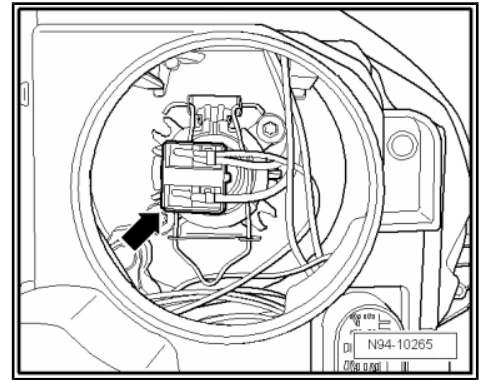

- Press spring retaining clip -2- in -direction of arrow- under the locking lugs-1- and fold spring retaining clip -2- upwards.

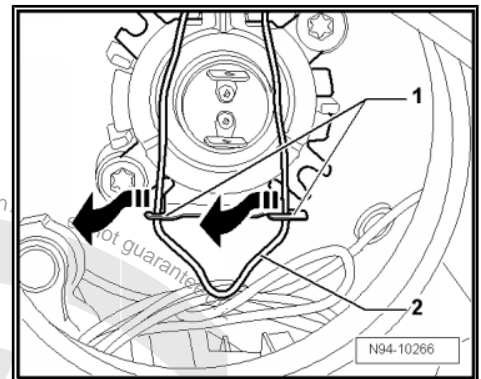

- Take main beam bulb -1- out of headlight.

Installing:



Note

- ◆ *When installing cap, ensure that it is seated correctly. The ingress of water will lead to permanent damage of the headlight.*
- ◆ *Do not touch bulb glass when fitting bulbs. Fingers leave traces of grease on the glass, which evaporate when the bulb is switched on and cause the glass to cloud over.*

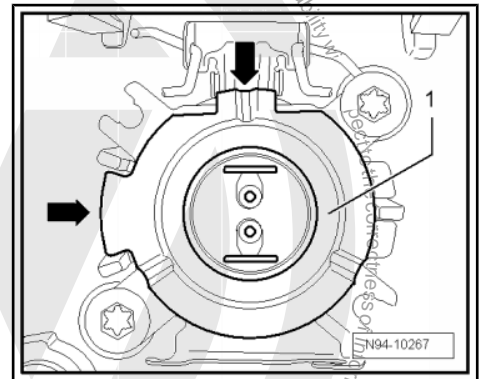

Installation is performed in the reverse order of installation; when doing this, note the following:

- Place the headlight main beam bulb -1- in the recesses -arrows- on the headlight.
- Check function of headlight.
- Check headlight setting and adjust headlight as necessary
 => Maintenance ; Booklet 20.1

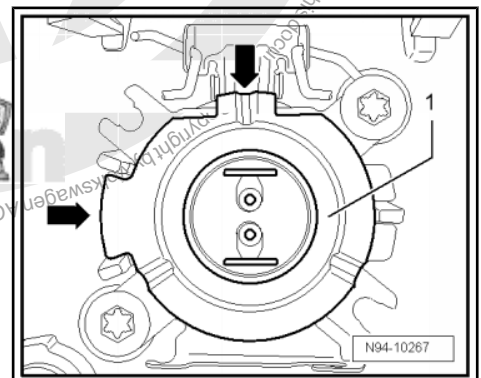



2.4.3 Renewing side light bulb



Note

The following diagrams show renewal of the side light bulb for the left headlight.

Removing:

- Switch off ignition and all electrical consumers and pull out ignition key.
- Pull off cover cap -1-.

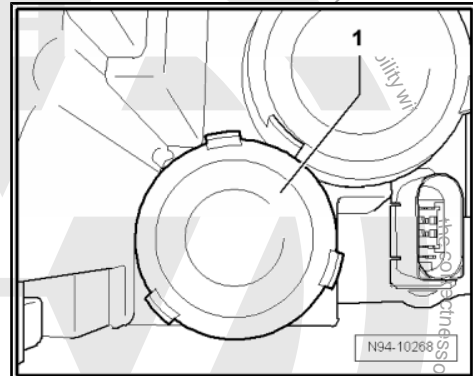

- Pull, depending on the cable length, the bulb holder -2- with the side light bulb as far as it is possible out of the reflector -1-.

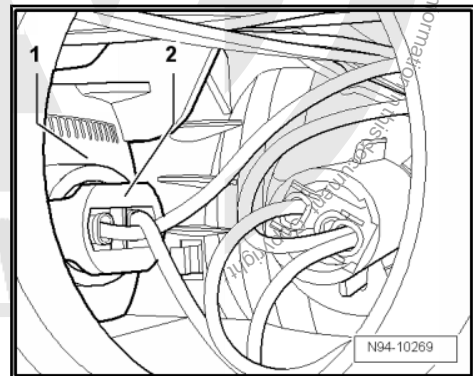

- Pull side light bulb -2- in -direction of arrow- out of the bulb holder -1-.

Installing:



Note

- ◆ When installing cap, ensure that it is seated correctly. The ingress of water will lead to permanent damage of the headlight.
- ◆ Do not touch bulb glass when fitting bulbs. Fingers leave traces of grease on the glass, which evaporate when the bulb is switched on and cause the glass to cloud over.

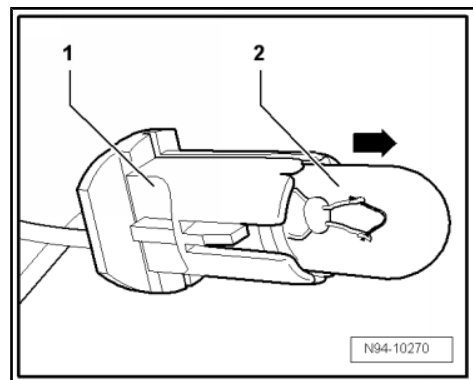

Installation is performed in the reverse order of installation; when doing this, note the following:

- Check function of headlight.
- Check headlight setting and adjust headlight as necessary
⇒ Maintenance ; Booklet 20.1



2.4.4 Renewing front turn signal bulb



Note

The following diagrams show renewal of the turn signal bulb for the left headlight.

Removing:

- Switch off ignition and all electrical consumers and pull out ignition key.
- Pull off cover cap -1-.

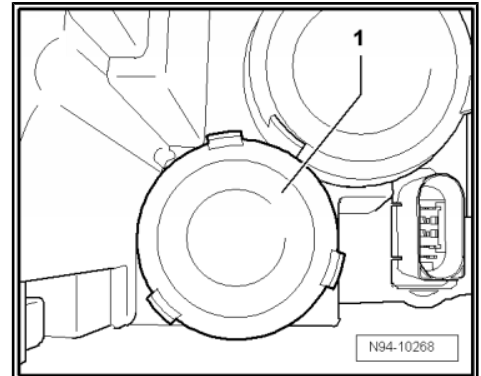

- Pull, depending on the cable length, the bulb holder -1- with the front turn signal bulb in -direction of arrow- and take them out of the reflector.

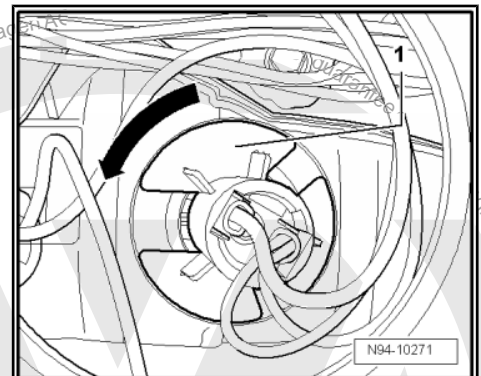

- Push front turn signal bulb -2- into bulb holder -1- and turn front turn signal bulb -2- in -direction of arrow-.
- Pull front turn signal bulb -2- out of the bulb holder -1-.

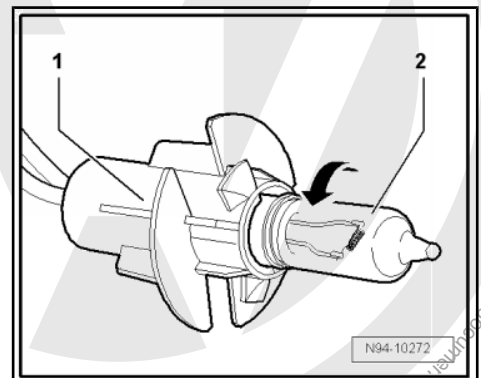

Installing:



Note

- ◆ When installing cap, ensure that it is seated correctly. The ingress of water will lead to permanent damage of the headlight.
- ◆ Do not touch bulb glass when fitting bulbs. Fingers leave traces of grease on the glass, which evaporate when the bulb is switched on and cause the glass to cloud over.

Installation is performed in the reverse order of installation; when doing this, note the following:

- Check function of headlight.
- Check headlight setting and adjust headlight as necessary
⇒ Maintenance ; Booklet 20.1



2.5 Removing and installing headlight range control motor

Information was not available when it was time of going to press.

2.6 Removing and installing gas discharge light control unit



Note

The left gas discharge light control unit -J343- or the right gas discharge light control unit -J344- are not capable of self-diagnosis.

Removing:

- Remove headlight ⇒ [page 181](#) .
- Remove securing bolts -arrows- of gas discharge light control unit -1-.



Note

When taking off the gas discharge light control unit the connectors must not be removed. The connector is fitted tightly to the headlight and is automatically disconnected when taking off the gas discharge light control unit .

- Take off gas discharge light control unit -1- from headlight.

Installing:



Note

When installing the gas discharge light control unit secure correct seat of the seal. The ingress of water will lead to permanent damage of the headlight.

Installation is performed in the reverse order of installation; when doing this, note the following:

- Check function of headlight.
- Perform basic setting of headlights ⇒ Maintenance ; Booklet 20.1 .

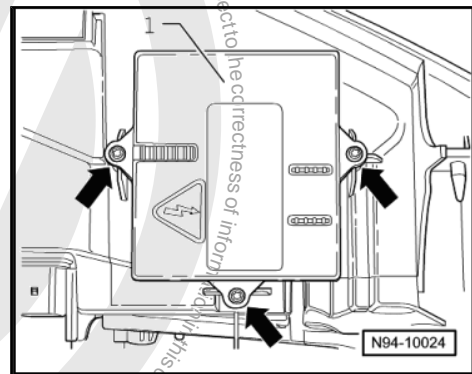

2.7 Headlight range control unit -J431-

2.7.1 Removing and installing headlight range control motor -J431-

Special tools and workshop equipment required



◆ Removal wedge -VAS 3409-

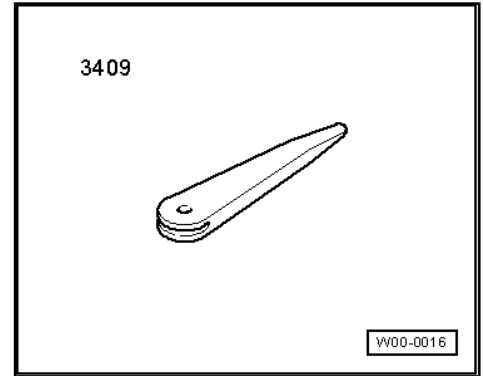

i Note

When removing and installing components in visual area (connectors, covers, trims etc.) apply a commercial adhesive tape where a lever tool is applied (removal wedge -VAS 3409-, screwdriver).

Removing:

- Switch off ignition and all electrical consumers and pull out ignition key.
- Remove lateral cover -1- out of the dash panel, by inserting the removal wedge -VAS 3409- or a screwdriver in the recess -2- and lever off cover-1- in -direction of arrow-.

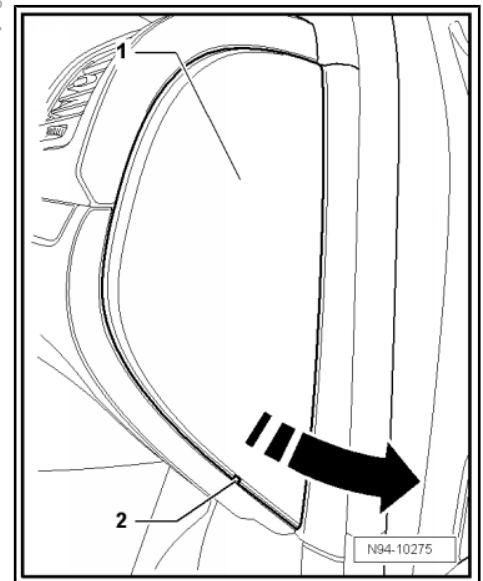

- Unlock the locking clip -1- in -direction of arrow- and pull off connector -2- from control unit for headlight range control -J431- .

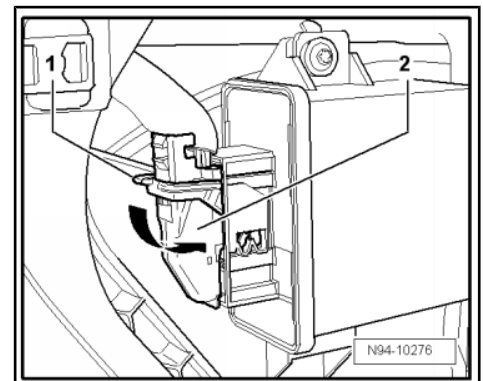



- Unscrew securing bolt -arrow- and take control unit for headlight range control -J431- -1- of bracket -2-.

Installing:

Installation is performed in the reverse order of installation; when doing this, note the following:

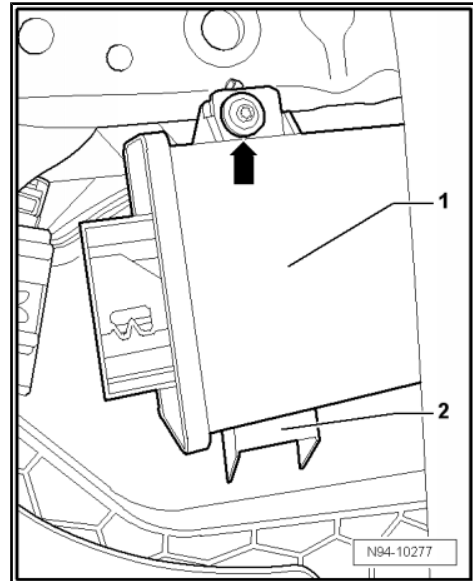

- Fit the control unit for headlight range control -J431- -3- into the bracket -2- with the lug -2-.

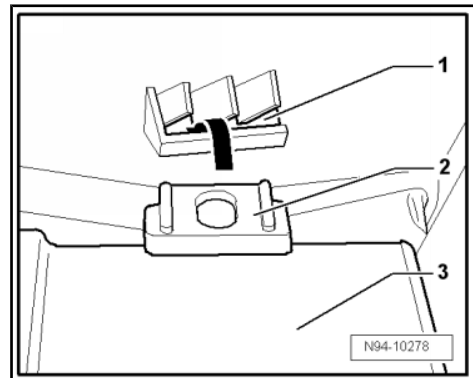

- Lock connector -1- by pressing the locking clip -2- in -direction of arrow-.



Note

After installing a new control unit for headlight range control -J431- it must be coded => [page 200](#) .

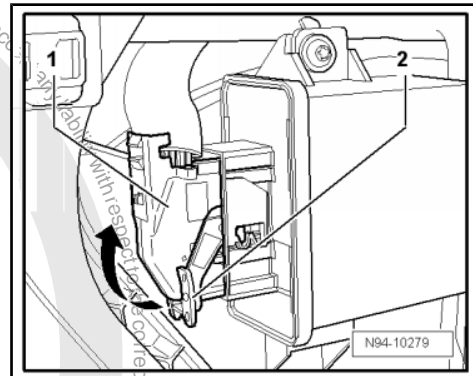

2.7.2 Coding control unit for headlight range control -J431-

- Connect the vehicle diagnosis, testing and information system -VAS 5051A- to => [page 281](#)
- Select "guided fault finding" in Vehicle Diagnosis, Testing and Information System -VAS 5051A- .
- Using the "Go to" key, select "Function/component selection" and the following menu items one after the other:
 - ◆ Body
 - ◆ Electrical System
 - ◆ 01 - On Board Diagnostic capable systems



- ◆ Automatic headlight range control
- ◆ Automatic headlight range control functions
- ◆ Coding automatic headlight range control

i Note

If the control unit for headlight range control -J431- has been coded, the basic setting of the headlights must be performed after having coded the control unit ⇒ Maintenance ; Booklet 20.1 .

2.8 Vehicle level sender

There is a vehicle level sender located on the front axle (front left vehicle level sender -G78-) and on the rear axle (rear left vehicle level sender -G76-).

i Note

- ◆ *If the vehicle level senders are replaced, check the values from the sensors ⇒ [page 203](#) and carry out basic setting on headlights ⇒ Maintenance ; Booklet 20.1 .*
- ◆ *If the values from the vehicle level sensors are outside the specified tolerance, basic headlight setting cannot be carried out.*

2.8.1 Removing and installing front left vehicle level sender -G78-

Removing:

- Switch off ignition and all electrical consumers and pull out ignition key.
- Pull off connector -arrow-.

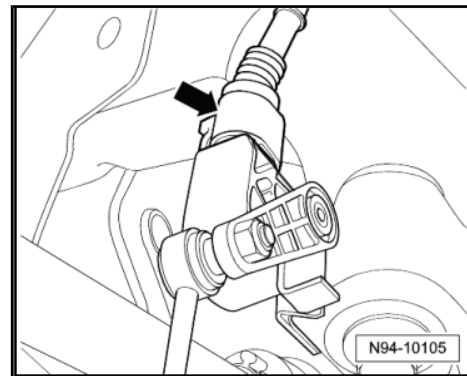



- Remove securing nut -1-.
- Unscrew securing bolt -2- and remove front left vehicle level sender -G78- -3-.

Installing:

Installation is carried out in the reverse order. When installing, note the following:

- Tighten threaded connections to specified torque settings
⇒ [page 238](#) .
- Check front left vehicle level sender -G78- ⇒ [page 203](#) .
- Perform basic setting of headlights ⇒ Maintenance ; Booklet 20.1 .

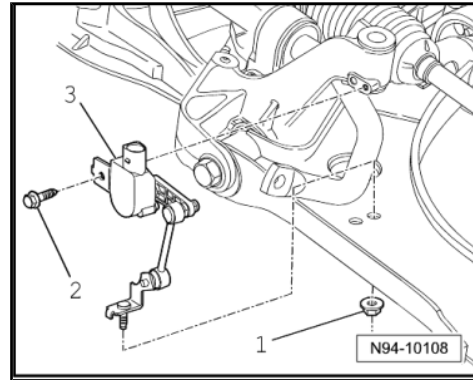

Note

- ◆ If the vehicle level sensors are replaced, check the sensor values ⇒ [page 203](#) and carry out basic setting on headlights ⇒ Maintenance ; Booklet 20.1 .
- ◆ If the values from the vehicle level sensors are outside the specified tolerance, basic headlight setting cannot be carried out.

2.8.2 Removing and installing rear left vehicle level sender -G76-

Removing:

- Switch off ignition and all electrical consumers and pull out ignition key.
- Pull off connector -arrow-.

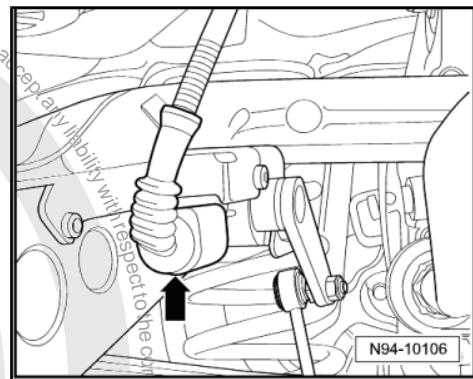



- Unscrew the five securing bolts -1- and remove rear left vehicle sender -G76- -2-.

Installing:

Installation is carried out in the reverse order. When installing, note the following:

- Tighten threaded connections to specified torque settings ⇒ [page 238](#) .
- Check front left vehicle level sender -G76- ⇒ [page 203](#) .
- Perform basic setting of headlights ⇒ Maintenance ; Booklet 20.1 .

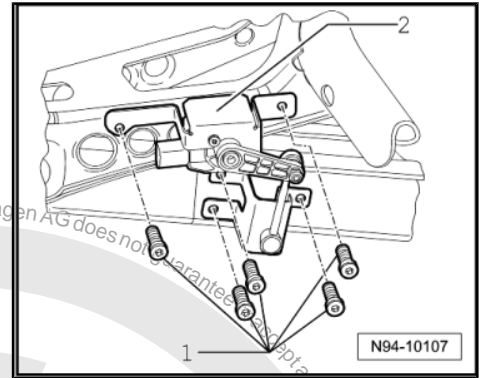

Note

- ◆ *If the vehicle level sensors are replaced, check the sensor values ⇒ [page 203](#) and carry out basic setting on headlights ⇒ Maintenance ; Booklet 20.1 .*
- ◆ *If the values from the vehicle level sensors are outside the specified tolerance, basic headlight setting cannot be carried out.*

2.8.3 Checking vehicle level sender

The vehicle level senders transmit the longitudinal inclination angle of the vehicle by way of signals to the headlight range control unit -J431- .

It must then be confirmed whether the rear left vehicle level sensor -G76- and front left vehicle level sensor -G78- are supplying the headlight range adjustment unit -J431- with plausible signals.

No fault entry is stored in the headlight range control unit -J431- in the following instances:

- ◆ Vehicle level senders installed are not of type specified in this workshop manual
- ◆ Vehicle level senders have mechanical fault
- ◆ Vehicle suspension has been modified (e.g. lowered)



Note

If the values of the vehicle level senders are outside the specified tolerance, basic headlight setting cannot be carried out.

- Connect the vehicle diagnosis, testing and information system -VAS 5051A- to ⇒ [page 281](#)
- Select “guided fault finding” in Vehicle Diagnosis, Testing and Information System -VAS 5051A- .
- Using the “Go to” key, select “Function/component selection” and the following menu items one after the other:
 - ◆ Body
 - ◆ Electrical System
 - ◆ 01 - On Board Diagnostic capable systems
 - ◆ Automatic headlight range control
 - ◆ Automatic headlight range control functions
 - ◆ Checking vehicle level sender



2.9 Servicing headlight securing lugs

Information on servicing headlight securing lugs was not available when it was time of going to press.

2.10 Adjusting headlights

Adjusting headlights with gas discharge lamp ⇒ Maintenance ;
Booklet 20.1 .





3 Fog lights

Fault detection and fault display:

The onboard supply control unit has a self-diagnosis function, which makes fault finding on the fog lights easier.

For fault finding, use the vehicle diagnosis, testing and information system -VAS 5051A- in "guided fault finding" mode.

3.1 Assembly overview - fog light

Torque settings ⇒ [page 238](#)

1 - Front bumper

2 - Vent hose

3 - Left fog light bulb -L22- or
right fog light bulb -L23-

- Bulb H11 12 V, 55 W
- Removing and installing
⇒ [page 206](#)

4 - Fog light housing

- Removing and installing
⇒ [page 205](#)

5 - Cover cap

6 - Securing bolts

7 - Spreader nuts

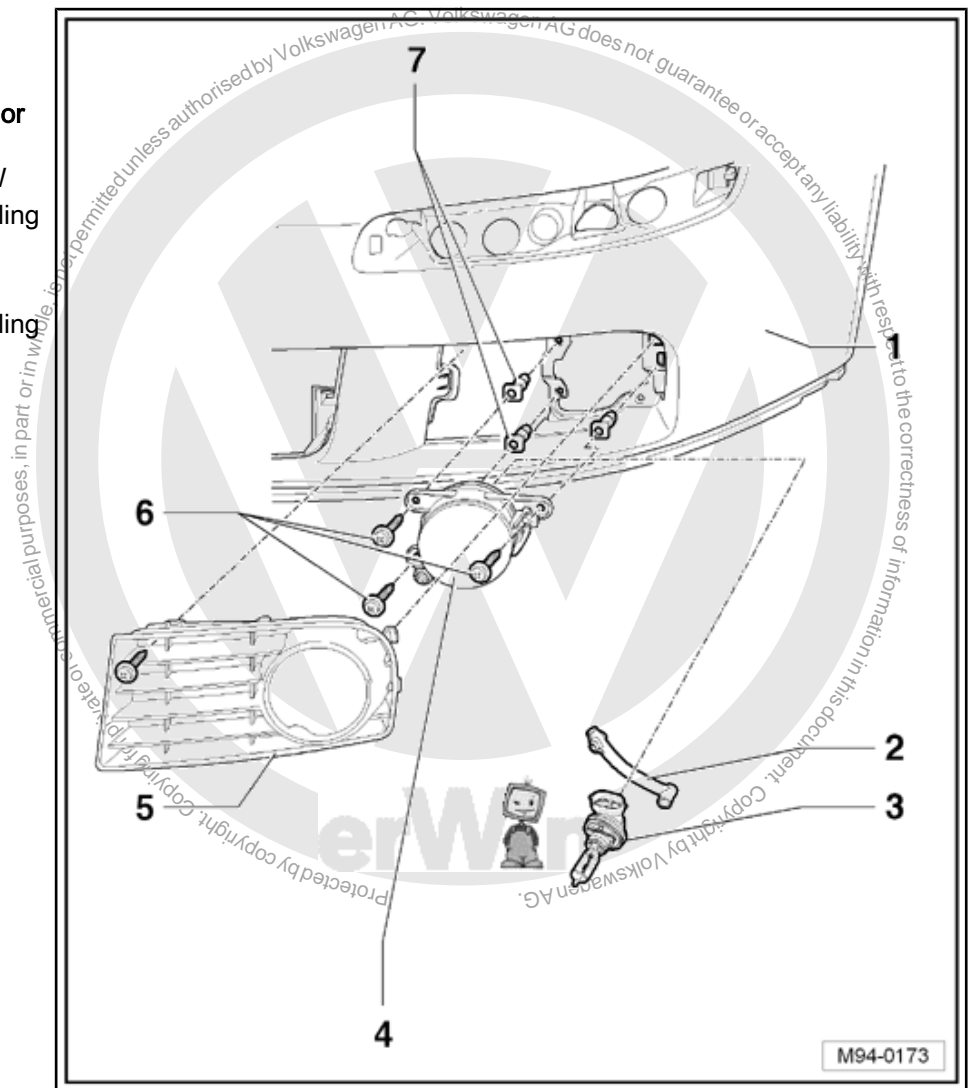

3.2 Removing and installing fog lights



Note

The diagrams show how the left fog light is removed and installed.



Removing:

- Switch off ignition and all electrical consumers and pull out ignition key.
- Remove bolt -2-.
- Unclip cover cap -2- off locking device.

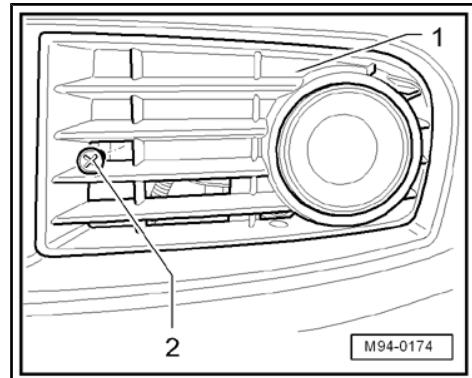

- Unbolt securing bolts -arrow-.

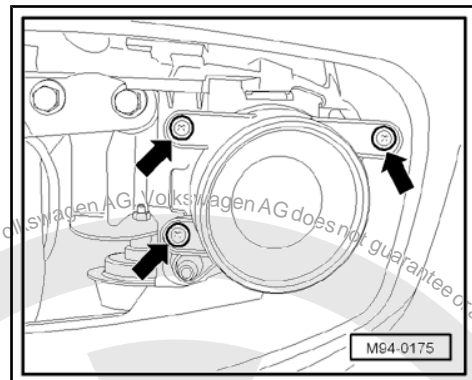

- Pull fog light housing out of front bumper and disconnect connector -arrow-.

Installing:

Installation is performed in the reverse order of installation; when doing this, note the following:

- Check functions of headlight.
- Check fog light adjustment, adjusting if necessary => Maintenance ; Booklet 20.1 .

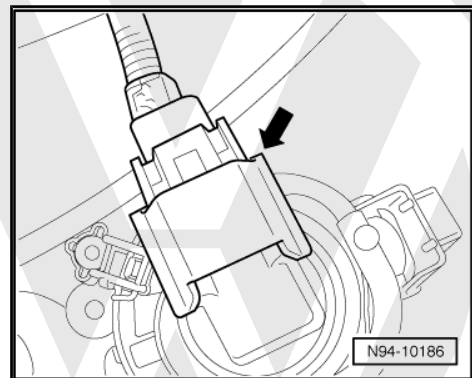

3.3 Removing and installing fog light bulb



Note

The diagram shows how the left fog light is removed and installed.

Removing:

- Remove fog light => [page 205](#) .



- Turn bulb holder -1- in -direction of arrow- and take out of fog light.

The bulb for the fog light is permanently attached to the bulb holder and cannot be renewed separately.

Fog light bulb : H11 12 V, 55 W

Installing:

Installation is performed in the reverse order of installation; when doing this, note the following:

- Check functions of headlight.
- Check fog light adjustment, adjusting if necessary → Maintenance ; Booklet 20.1 .

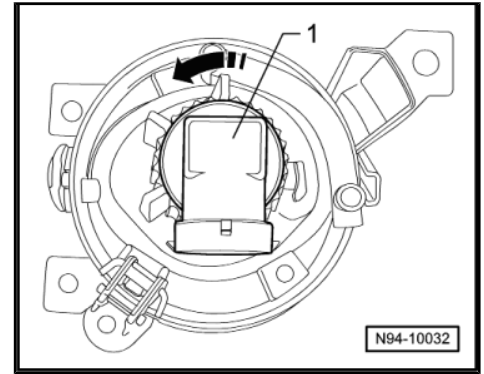

3.4 Adjusting fog lights

Adjusting fog lights → Maintenance ; Booklet 20.1 .





4 Removing and installing side marker in front bumper

4.1 Removing and installing front side marker

Removing



Note

Removal and installation of front side marker on left and right are identical.

- Remove noise insulation => General Body Repairs, Exterior; Rep. Gr. 50 ; Assembly overview - noise insulation
- Unlock side marker -1- by pressing the locking lug -in direction of arrow-.
- Remove bulb holder -2- out of side marker

Installing

Installation is performed in the reverse order of installation; when doing this, note the following:



Note

After the installation perform functional check.

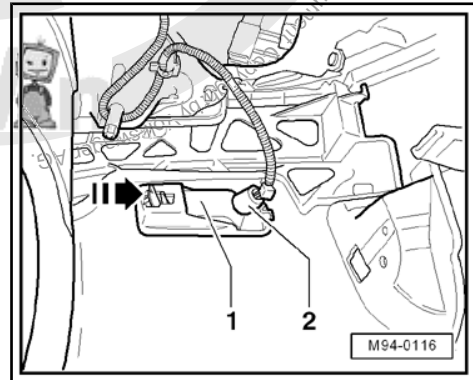

4.1.1 Renewing side marker bulb

- Pull side marker bulb -1- in direction of arrow out of the bulb holder -2-.

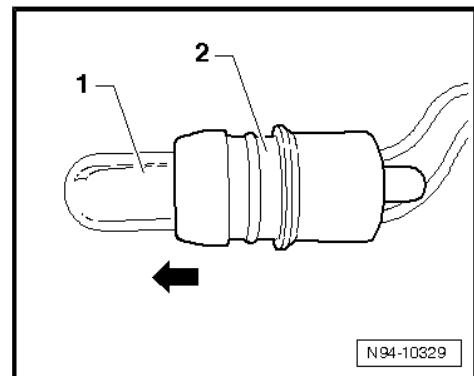



5 Mirror turn signal bulb and entry light in exterior mirror



Note

Additional information:

⇒ Current flow diagrams, Electrical fault finding and Fitting locations

General description:

The exterior mirror turn signal bulbs are located in the housing of the exterior mirror.

Furthermore there is located an entry light on each side in the housing, which illuminates the entry area around the driver and front passenger side.

1 - Driver side exterior mirror turn signal bulb -L131- or front passenger side exterior mirror turn signal bulb -L132-

2 - Driver side entry light in exterior mirror -W52- or front passenger side entry light in exterior mirror -W53-

Fault detection and fault display:

The onboard supply control unit is equipped with self-diagnosis which makes fault finding easier.

For fault finding, use the vehicle diagnosis, testing and information system -VAS 5051A- in "guided fault finding" mode.

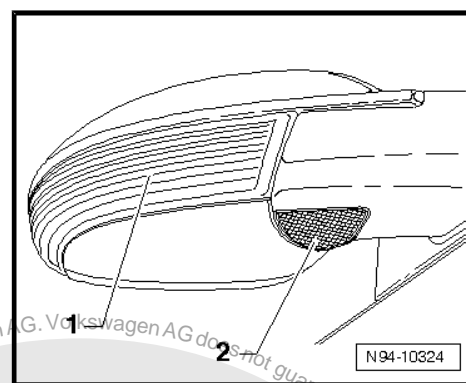

5.1 Removing and installing turn signal bulb

The driver side exterior mirror turn signal bulb -L131- or the front passenger side exterior mirror turn signal bulb -L132- is installed in the housing of the left or right exterior mirror.



Note

The complete driver side exterior mirror turn signal bulb -L131- or the complete front passenger side exterior mirror turn signal bulb -L132- must be replaced if damaged.

Removing:

- Switch off ignition and all electrical consumers and pull out ignition key.
- Remove driver side exterior mirror turn signal bulb -L131- or the front passenger side exterior mirror turn signal bulb -L132- ⇒ General Body Repairs, Exterior; Rep. Gr. 66 ; Exterior rear view mirror; Removing and installing side mounted turn signals .

Installing:

- Install driver side exterior mirror turn signal bulb -L131- or the front passenger side exterior mirror turn signal bulb -L132- ⇒ General Body Repairs, Exterior; Rep. Gr. 66 ; Exterior rear view mirror; Removing and installing side mounted turn signals .



5.2 Removing and installing entry light in exterior mirror

The driver side entry light in exterior mirror -W52- or the front passenger side entry light in exterior mirror -W53- is installed in the housing of the left or right exterior mirror.



Note

- ◆ *To remove and install the entry lights the exterior mirror must not be removed.*
- ◆ *Removal and reinstallation of entry lights is carried out in the same manner on both sides and is described for one side only.*

Removing:

- Switch off ignition and all electrical consumers and pull out ignition key.
- Fold exterior mirror -1- in -direction of arrow- forwards.

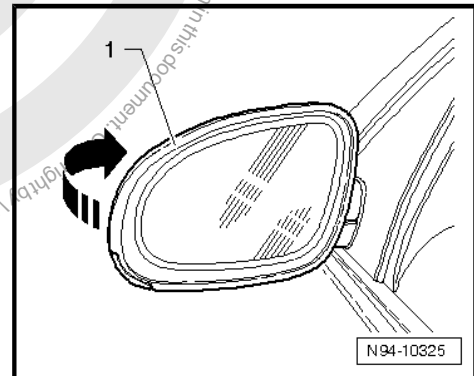

- Unbolt securing bolt -1-.

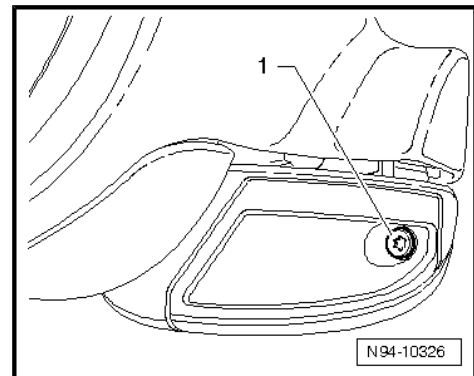

- Unclip entry light in -direction of arrow- out of the exterior mirror and pull it out as far as possible.

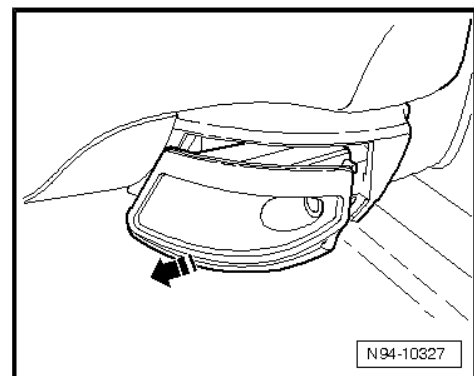



- Pull bulb carrier -2- in -direction of arrow- out of entry light housing -1-.

Renew bulb:

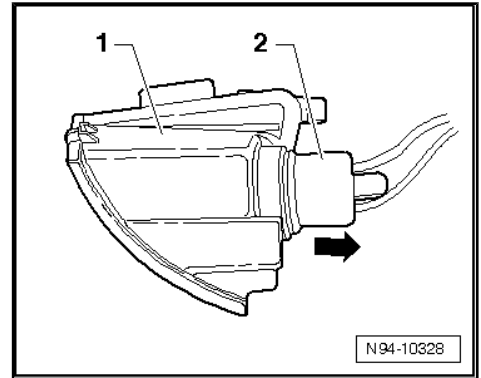

- Pull bulb -1- in -direction of arrow- out of the carrier -2-.

Plug base bulb: 12 V, W6 W

Installing:

Installation is performed in the reverse order of installation; when doing this, note the following:



Note

After the installation perform functional check of the exterior mirror.

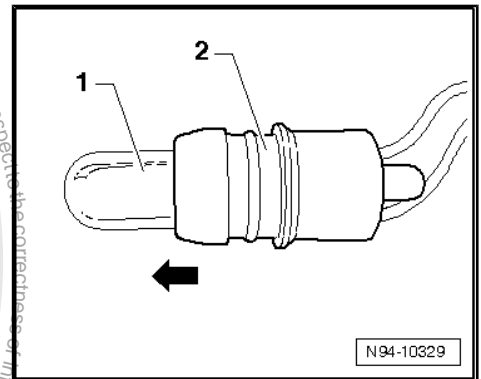

Protected by copyright. Copying for private or commercial purposes, in part or in whole, is not permitted unless authorised by Volkswagen AG. Volkswagen AG does not guarantee or accept any liability with respect to the correctness of information in this document. Copyright by Volkswagen AG.



6 Tail lights

6.1 Assembly overview - tail light in side panel

Torque settings ⇒ [page 238](#)

1 - Securing nuts

2 - Left brake and tail light bulb -M21- or right brake and tail light bulb -M22-

3 - Tail light housing in side panel

- ❑ Removing and installing ⇒ [page 212](#)

4 - Bulb for left brake, blinker and tail light 2 -M72- or bulb for right brake, blinker and tail light 2 -M73-

5 - Bulb carrier

- ❑ Removing and installing ⇒ [page 213](#)

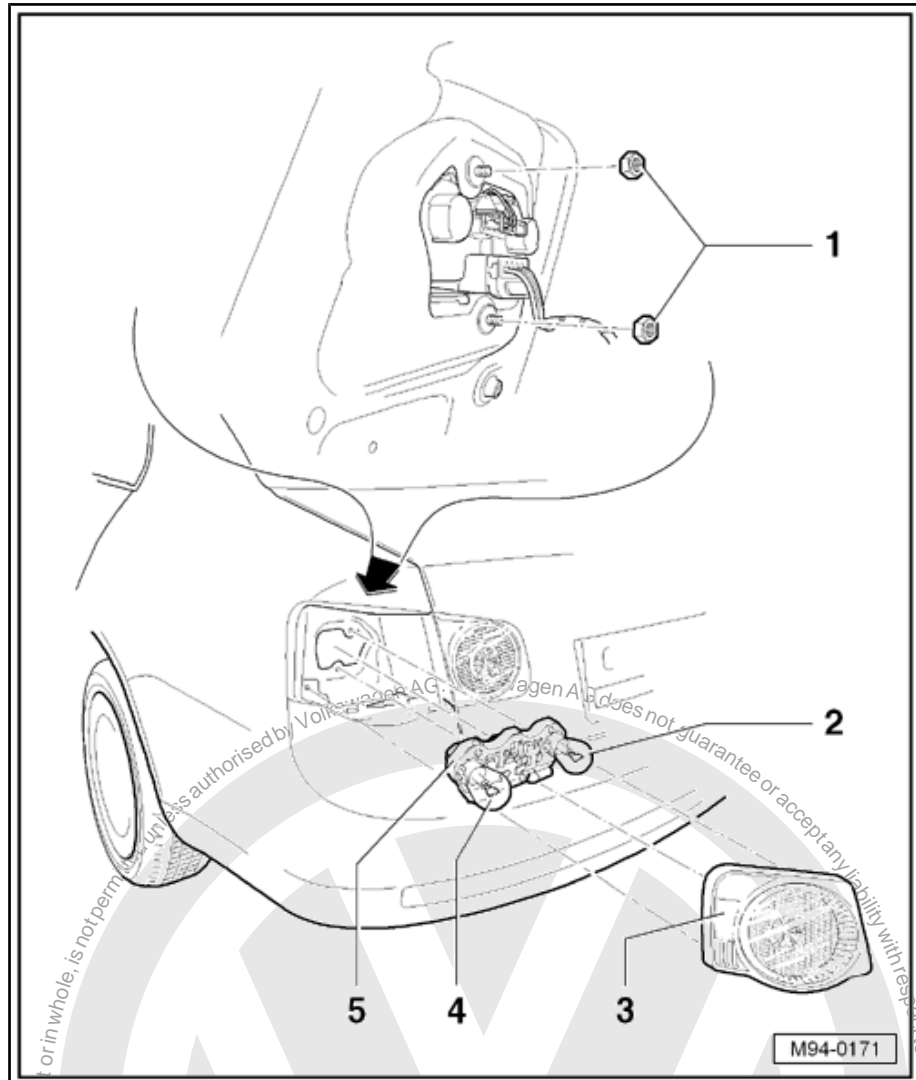

6.2 Removing and installing tail light in side panel

Removing:

- Switch off ignition and all electrical consumers and pull out ignition key.
- Press side trim to side.



- Pull connector -1- off.
- Remove securing nuts -2- on tail light in side panel.
- Remove tail light.

Installing:

Installation is performed in the reverse order of installation; when doing this, note the following:

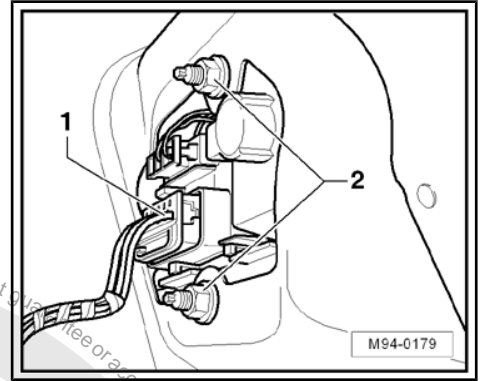

- Tighten securing nuts -2- to specified tightening torque => [page 238](#) .



Note

The tail light connector in the side panel must "audibly" engage.

- When installation is complete, check shutlines of tail light to body.

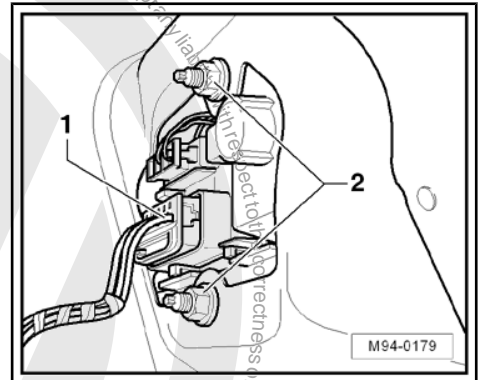

6.3 Removing and installing tail light bulb carrier in side panel

Removing:

- Pull connector -1- off.

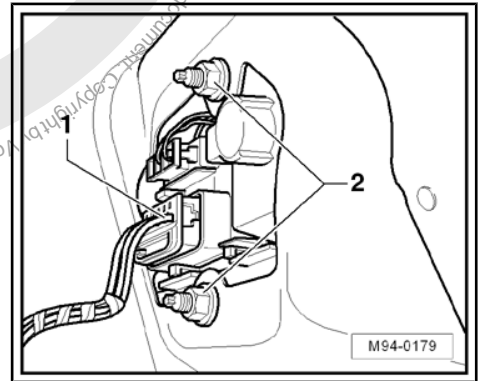

- Unclip retaining tabs -1- -in direction of arrow- and take bulb carrier out of tail light housing -2-.

Installing:

Install in reverse order of removal.

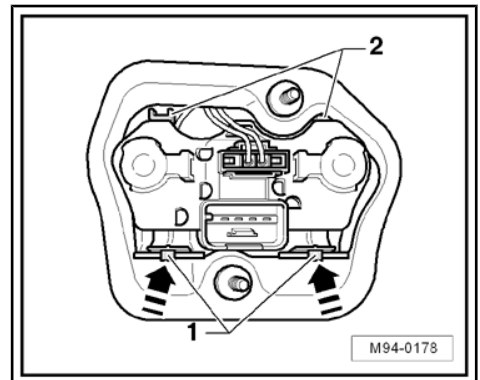



6.4 Assembly overview - tail light in tailgate

Torque settings ⇒ [page 238](#)

1 - Securing nuts

2 - Bulb carrier

- Removing and installing
⇒ [page 215](#)

3 - Left reversing light bulb - M16- or right reversing light bulb -M17-

- 12 V, P 21 W

4 - Tail light housing in tailgate

- Removing and installing
⇒ [page 214](#)

5 - Plain washer

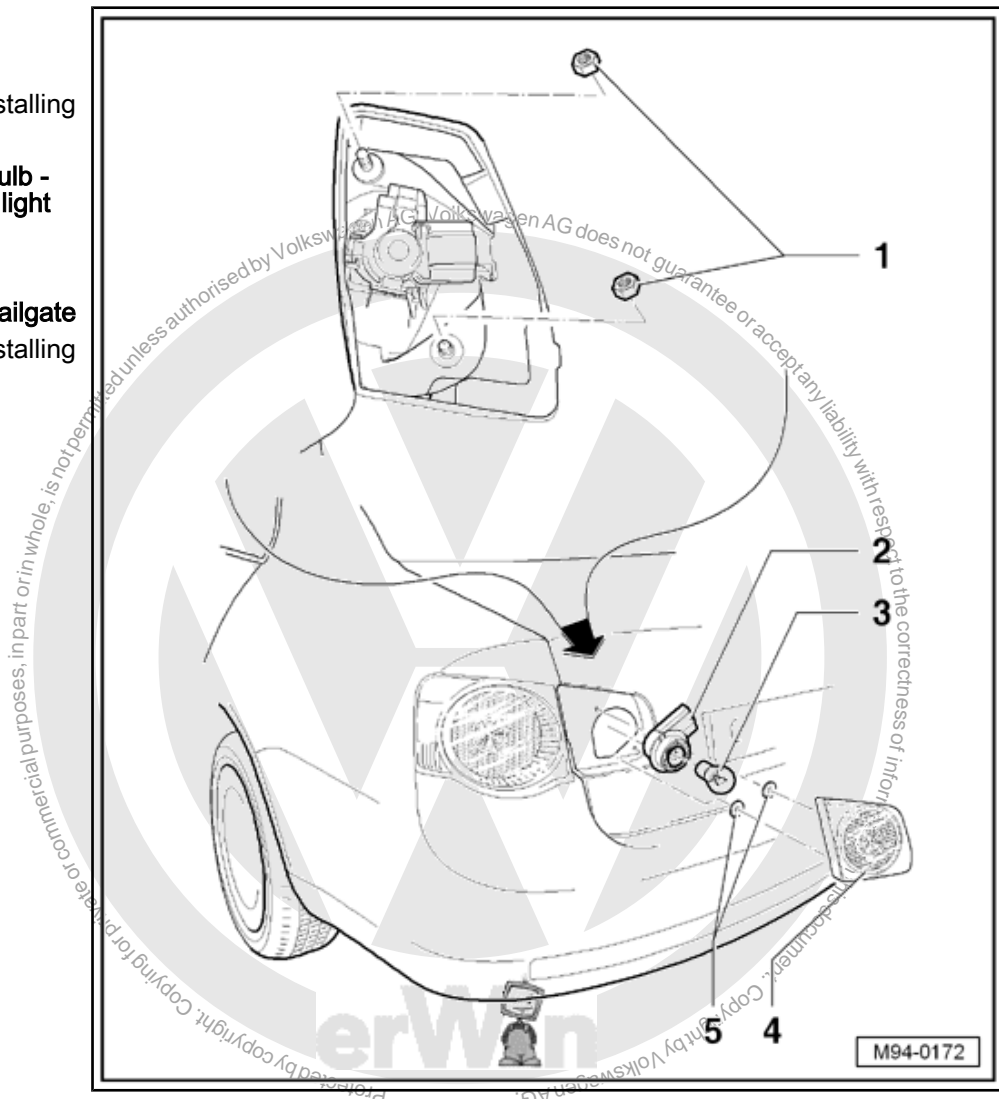

6.5 Removing and installing tail light in tailgate

Removing:

- Switch off ignition and all electrical consumers and pull out ignition key.
- Unclip service cover out of trim in tailgate



- Pull connector -2- off.
- Remove securing nuts -1- on tail light in tailgate.
- Remove tail light.

Installing:

Installation is performed in the reverse order of installation; when doing this, note the following:

- Secure washer -2- with an adhesive point (e.g. Loctite) before fitting on threaded domes -1-, to prevent from falling in the body.
- Fit the washers -2- on the threaded domes -1-.

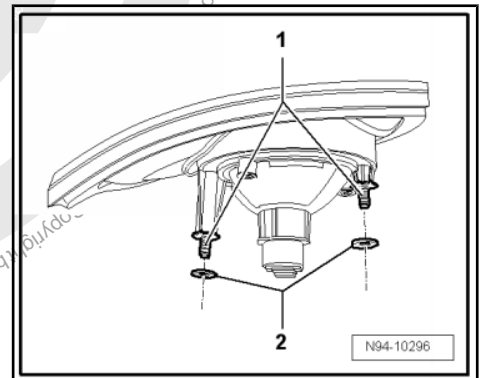
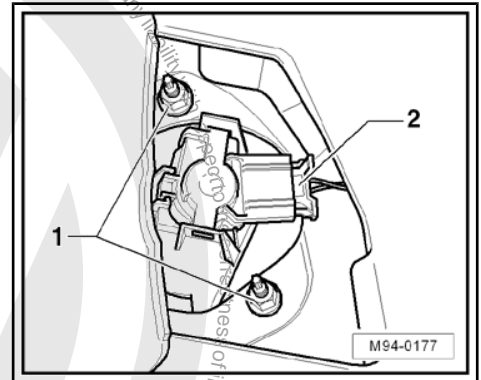

- Tighten securing nuts -1- to specified tightening torque => [page 238](#) .
- Fit connector -2- on bulb carrier.
- When installation is complete, check shutlines of tail light to body.

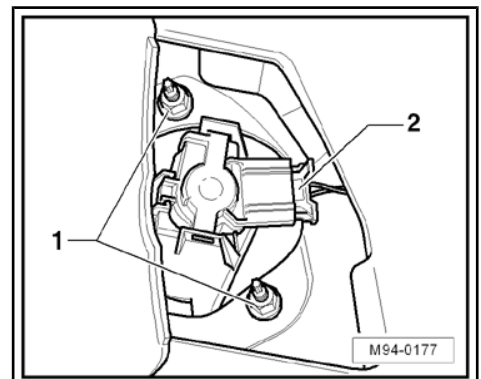

6.6 Removing and installing tail light bulb carrier in tailgate

Removing:

- Switch off ignition and all electrical consumers and pull out ignition key.
- Unclip service cover out of trim in tailgate
- Pull connector -2- off.



Note

The lower tail light trim must not be removed. For reasons of clarity the lower tailgate trim is not shown in the following figure.

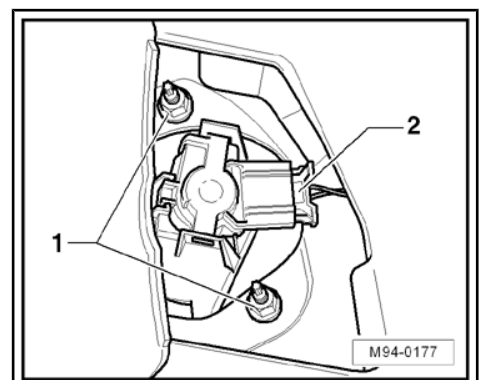



- Unclip the two retaining tabs -in direction of arrow- and take bulb carrier -1- out.

Installing:

Install in reverse order of removal.

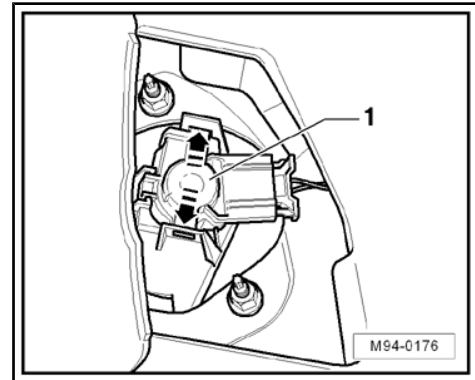



7 Number plate lights

7.1 Removing and installing number plate light -X-

Removing:

- Switch off ignition and all electrical consumers and pull out ignition key.
- Remove securing bolts -arrows- of number plate light -X- .
- Take the lens off together with the number plate light -X- .

Number plate light -X- : Soffitte 12 V, C 5 W

Installing:

Install in reverse order of removal.

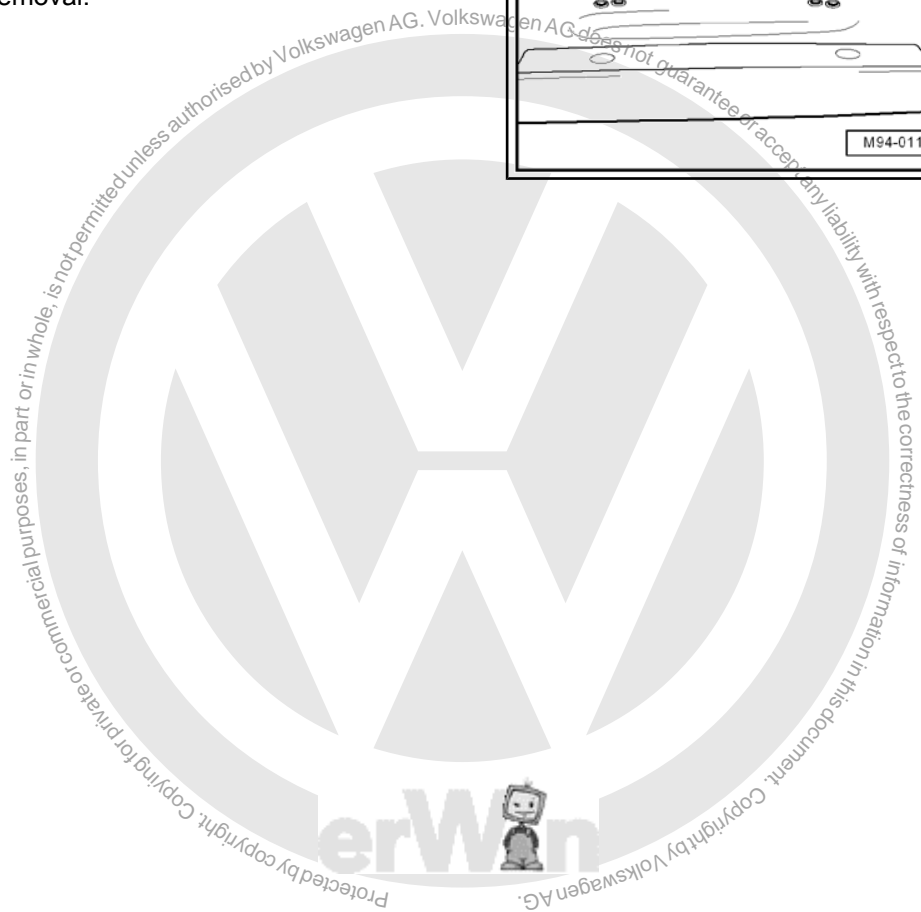
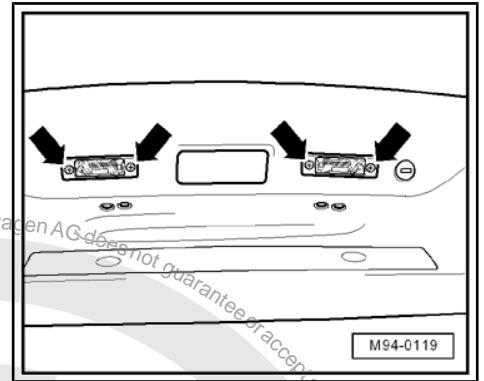



8 Additional brake light

8.1 Removing and installing high level brake light bulb -M25-



Note

In the event of damage, the complete high level brake light -M25- unit must be renewed.

Removing:

- Switch off ignition and all electrical consumers and pull out ignition key.
- Remove strip roof leading edge ⇒ General body repairs, interior; Rep. Gr. 70 ; Removing and installing strip roof leading edge .
- Pull connector -1- off.
- Press high level brake light bulb -M25- to rear window -in direction of arrow-

Installing:

Installation is performed in the reverse order of installation; when doing this, note the following:

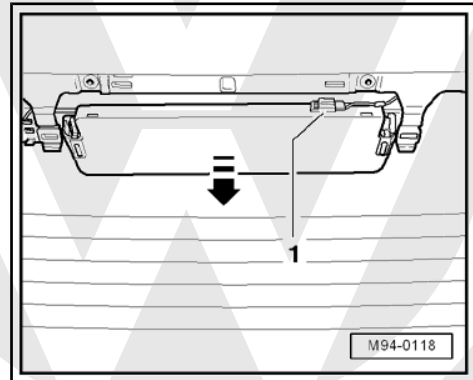



9 Steering column switch



Caution

Disconnecting and connecting the battery as described in the Workshop Manual ⇒ [page 29](#).



Note

- ◆ *After installing a new steering column electronics control unit -J527-, it must be coded ⇒ [page 227](#).*
- ◆ *In the event of faults in the steering column switch, the coding of the steering column electronics control unit -J527- must be checked ⇒ [page 227](#).*

Fault detection and fault display:

The steering column electronics control unit -J527- is equipped with self-diagnosis, which is designed to ease fault finding.

For fault finding, use the vehicle diagnosis, testing and information system -VAS 5051A- in "guided fault finding" mode.

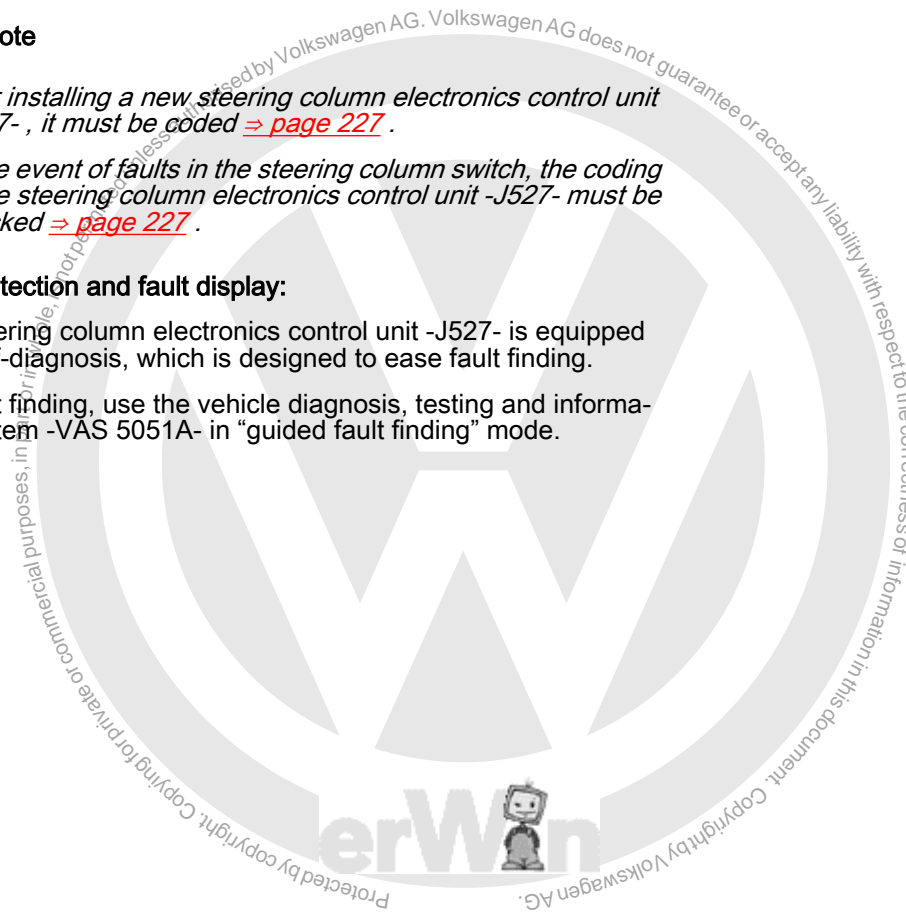



9.1 Assembly overview - steering column switch

1 - Turn signal switch

- Removing and installing ⇒ [page 224](#)
- The “turn signal switch” comprises of the following components turn signal switch -E2- , headlight dipper/flasher switch -E4- and, if fitted with cruise control system cruise control system switch -E45-
- The illustration shows the “turn signal switch” without cruise control system switch -E45-

2 - Steering column switch base

- Removing and installing ⇒ [page 226](#)

3 - Windscreen wiper switch - E-

- Removing and installing ⇒ [page 225](#)

4 - Securing bolt

5 - Steering column electronics control unit -J527-

- Removing and installing ⇒ [page 221](#)
- Coding ⇒ [page 227](#)
- Final control diagnosis ⇒ [page 227](#)

6 - Airbag coil connector and return ring with slip ring -F138-

- Removing and installing ⇒ [page 223](#)

7 - Steering angle sender -G85-

- Removing and installing ⇒ [page 224](#)
- Basic settings ⇒ [page 228](#)

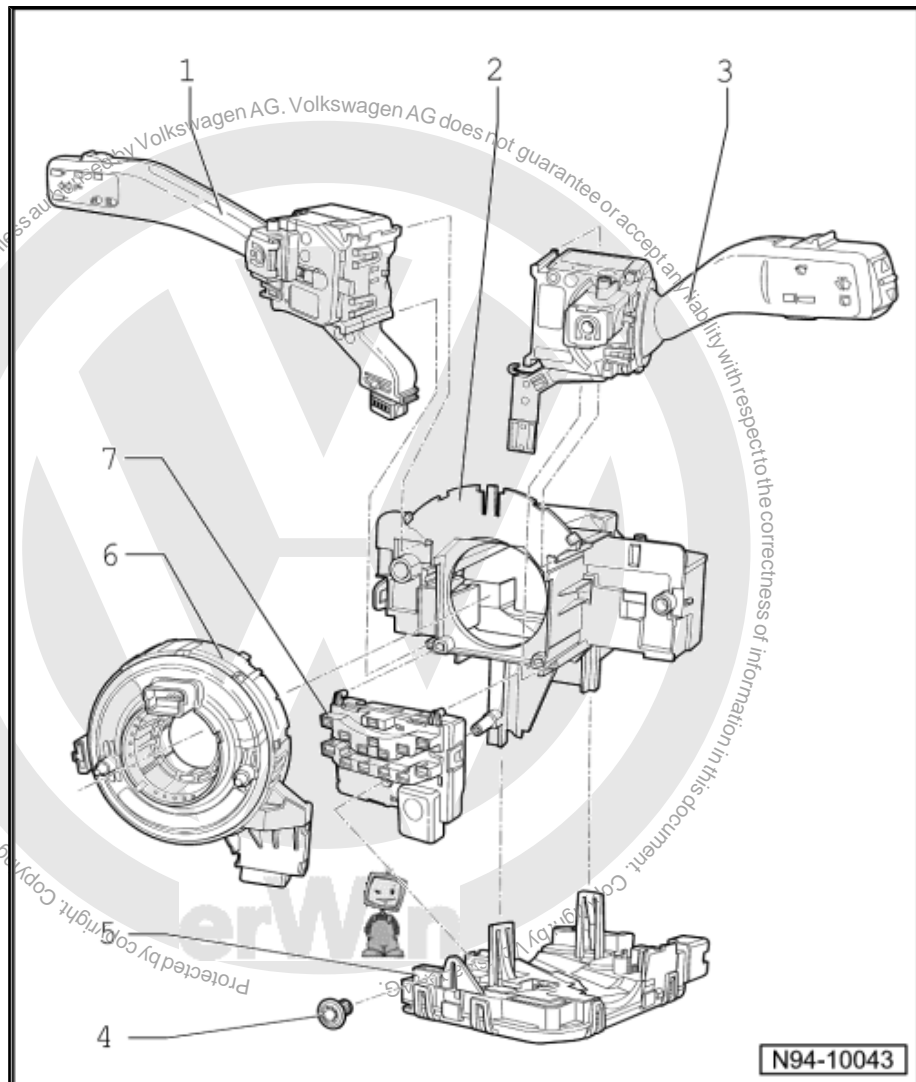

9.2 Removing and installing steering column switch



Caution

Disconnecting and connecting the battery as described in the Workshop Manual ⇒ [page 29](#) .



Note

When removing the steering column switch, observe that no metal shavings/swarf enter the steering column switch when drilling out the shear head bolts.

Removing:

For removal of the complete steering column switch, inc. base module, the switch is dismantled and the steering lock housing is also removed. For assembly of the steering lock housing, new shear head bolts are required. Even if just one component of the steering column switch is removed or renewed, the sequence described as follows must be observed.

- Disconnect the battery ⇒ [page 29](#) .
- Remove steering wheel ⇒ General body repairs, interior; Rep. Gr. 69 ; Airbag; Removing and installing steering wheel .
- Remove steering column trim ⇒ General body repairs, interior; Rep. Gr. 68 ; Compartments, covers and trim; Removing and installing steering column switch trim .

Remove components of steering column switch in the sequence as follows:

- ◆ Steering column electronics control unit -J527- ⇒ [page 221](#)
- ◆ Airbag coil connector and return ring with slip ring -F138- ⇒ [page 223](#)
- ◆ Steering angle sender -G85- ⇒ [page 224](#)
- ◆ Turn signal switch ⇒ [page 224](#)
- ◆ Windscreen wiper switch -E- ⇒ [page 225](#)
- ◆ Steering column switch base ⇒ [page 226](#)

Installing:

Install in reverse order of removal.

9.2.1 Removing and installing steering column electronics control unit -J527-



Note

- ◆ *After new control unit has been installed, it must be coded ⇒ "9.3 Steering column electronics control unit J527" [page 227](#) .*
- ◆ *In the event of faults in the steering column switch, the coding of the control unit must be checked ⇒ [page 227](#) .*



Removing:

- Unscrew bolt -1-.
- Insert a thin rod, e.g. of \varnothing 2.5 mm -2- approx. 45 mm in the hole -arrow 1- in steering column electronics control unit -J527- to release the locking tab -arrow 2-.

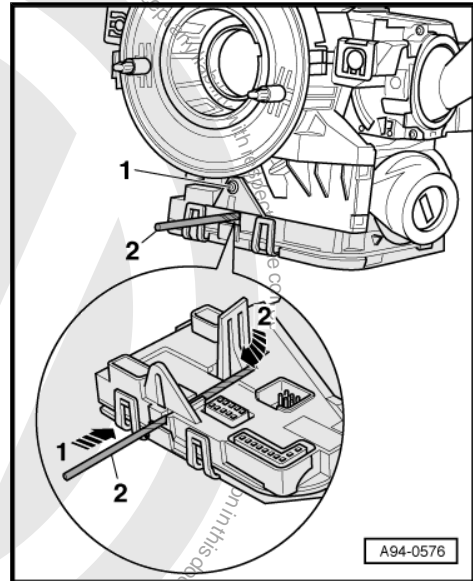

- Using a screwdriver, press against the rear securing clip -arrow- of the steering column electronics control unit -J527- .
- Carefully pull the steering column electronics control unit -J527- downwards off the steering column switch.

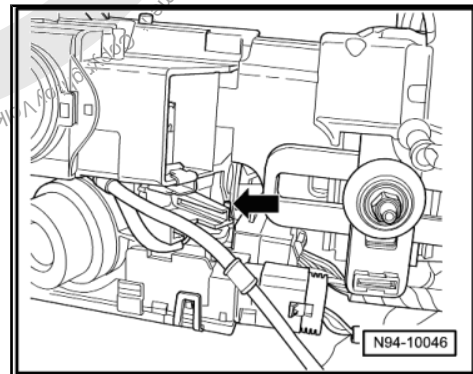

- Unclip -arrow A- connector -1- and separate from steering column electronics control unit -J527- .
- Remove locking device -3- out of connector.
- Unclip -arrow B- connector -2- and separate from steering column electronics control unit -J527- .

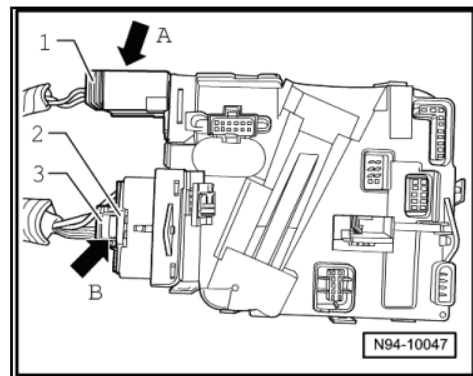

Installing:

Installation is performed in the reverse order of installation; when doing this, note the following:



Note

Ensure when fitting the connector that none of the pins become bent and that the connector can be heard to engage.



9.2.2 Removing and installing coil connector for airbag and reset ring with slip ring - F138-

Removing:



Note

The coil connector should not be moved out of the central position during removal and the road wheels should be in the "straight ahead" position.

- Lift up locking tabs -arrows- on coil connector -1- slightly and pull coil connector backwards off steering column and steering column switch.

Installing:

Installation is performed in the reverse order of installation; when doing this, note the following:



Note

For installation of the coil connector, the coil connector must be in the central position and the road wheels must be in the "straight ahead" position.

The central position (depending on manufacturer) of the coil connector is shown in the following diagram:

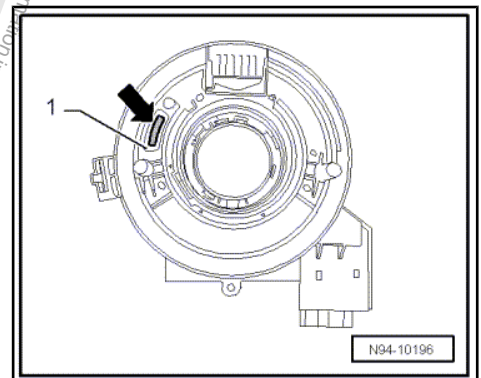
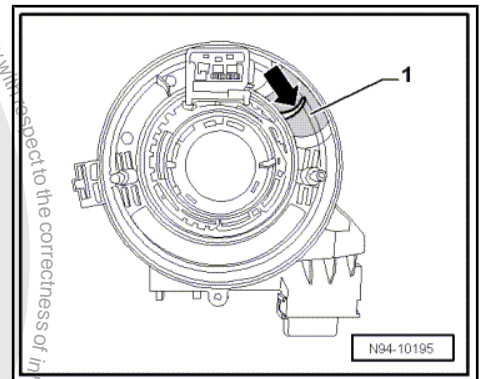
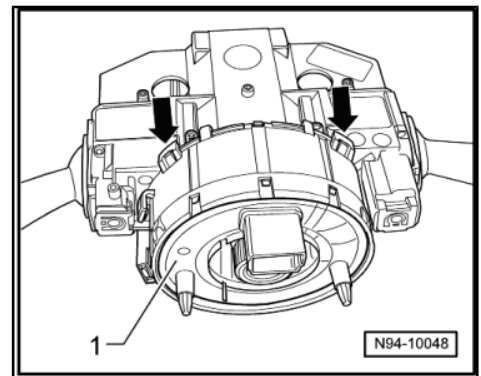

- ◆ The coloured strip (black rectangles) -arrow- must be in view -1-.
- ◆ The coloured strip (yellow) -arrow- must be in view -1-.



Note

If a new steering angle sensor -G85- is installed, this procedure must be followed by a "basic setting" => [page 228](#).



9.2.3 Removing and installing steering angle sensor -G85-

Removing:

- Pull the steering angle sender -G85- -1- backwards and away from the steering column switch -arrow-.

Installing:

Install in reverse order of removal.

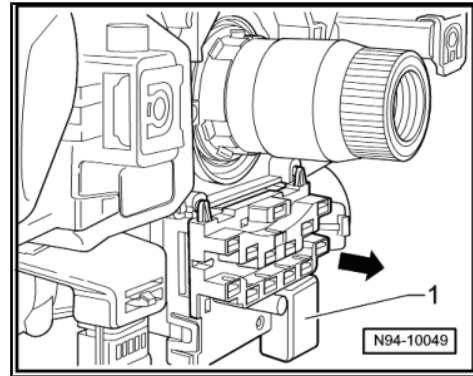

9.2.4 Removing and installing turn signal switch



Note

- ◆ The "turn signal switch" comprises of the following components turn signal switch -E2- , headlight dipper/flasher switch -E4- and, if fitted with cruise control system cruise control system switch -E45-
- ◆ For reasons of clarity, the steering column switch is shown with cruise control system switch -E45- .

Removing:

- Release retaining clips -arrows- using a 1.0 mm feeler gauge -1- and take "turn signal switch" off backwards.

Installing:

Installation is performed in the reverse order of installation; when doing this, note the following:



Note

The "turn signal switch" should be heard to engage.

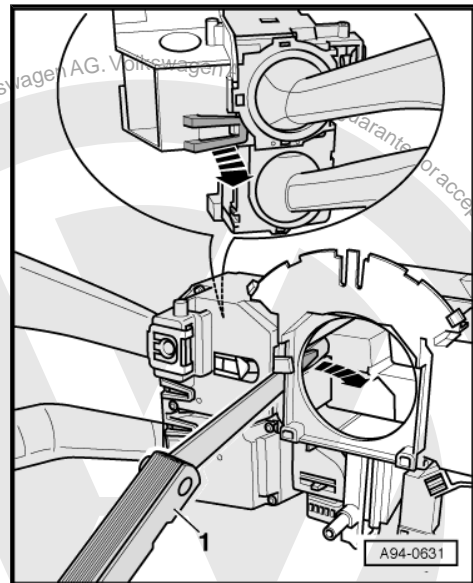



9.2.5 Removing and installing windscreen wiper switch -E-

Removing:



Note

For reasons of clarity, the steering column switch is shown in the removed state.

- Release retaining clips -arrows- using 1.0 mm feeler gauge -1- and take windscreen wiper switch -E- off backwards.

Installing:

Installation is performed in the reverse order of installation; when doing this, note the following:



Note

The windscreen wiper switch -E- should be heard to engage.

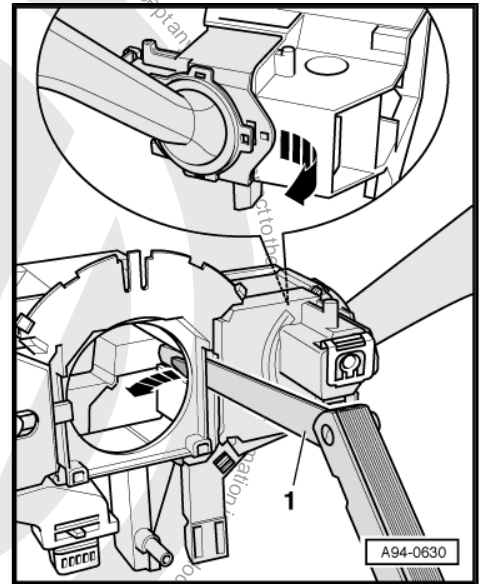



9.2.6 Removing and installing base module of steering column switch



Note

To remove the base module of the steering column switch -2- , the shear head bolts of the steering lock housing must be drilled out. To reinstall, new shear head bolts -1- are required ⇒ Parts catalogue (ETKA) .

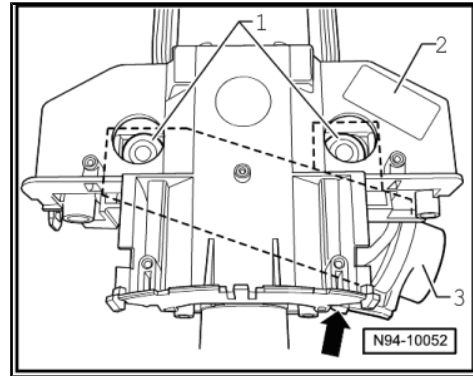

Caution

- ◆ Ensure that the components mounted on the basic brace have been removed before boring the shear head bolts.
- ◆ The boring operation can cause bore chips to penetrate the adjacent components resulting in damage and/or malfunction!
- ◆ Please remove the components in the specified sequence.



Caution

Disconnecting and connecting the battery as described in the Workshop Manual ⇒ [page 29](#) .

Removing:

- Disconnect the battery ⇒ [page 29](#) .

Remove the following components in sequence:

- Remove steering wheel ⇒ General body repairs, interior; Rep. Gr. 69 ; Airbag; Removing and installing steering wheel .
- Remove steering column trim ⇒ General body repairs, interior; Rep. Gr. 68 ; Compartments, covers and trim; Removing and installing steering column switch trim .
- Remove steering column electronics control unit -J527- ⇒ [page 221](#) .
- Remove coil spring for airbag/coil connector with slip ring - F138- ⇒ [page 223](#) .
- Remove steering angle sender -G85- ⇒ [page 224](#) .
- Remove the turn signal light switch -E2- ⇒ [page 224](#) .
- Remove windscreen wiper switch -E- ⇒ [page 225](#) .
- Disconnect connector -arrow- at reader coil -3-.

The basic brace can be removed once all the components mounted on it have been dismantled:

- Drill out securing bolts -1- of steering lock housing -3-.



Note

Bolts M8 -1-, core diameter 6.8 mm.



- Pull steering lock housing and base module of steering column switch -2- to rear off steering column.
- Take steering lock housing off base module of steering column switch.

Installing:

- Place the steering lock housing into the basic for the steering column switch.
- Push base module of steering column switch -2- as far as possible onto steering column.
- Fit connector -arrow- at reader coil -3-.
- Tighten the new shear head bolts -1- to steering column.
- Tighten the new shear head bolts -1- until bolt heads shear off.
- Install all parts in reverse order of removal.

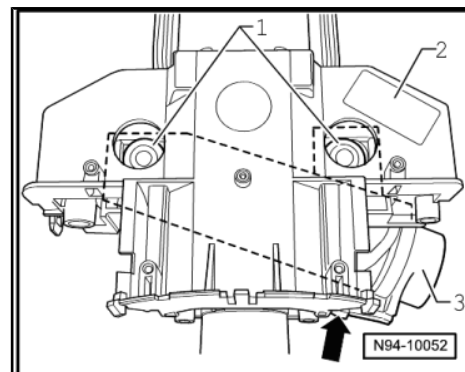

9.3 Steering column electronics control unit -J527-

Removing and installing steering column electronics control unit -J527- ⇒ [page 221](#)

9.3.1 Coding steering column electronics control unit -J527-

- Connect the vehicle diagnosis, testing and information system -VAS 5051A- to ⇒ [page 281](#)
- Select "guided fault finding" in Vehicle Diagnosis, Testing and Information System -VAS 5051A- .
- Using the "Go to" key, select "Function/component selection" and the following menu items one after the other:
 - ◆ Body
 - ◆ Electrical System
 - ◆ 01 - On Board Diagnostic capable systems
 - ◆ Steering wheel electronics
 - ◆ Steering wheel electronics functions
 - ◆ Coding control unit for steering wheel electronics

9.3.2 Steering column electronics control unit -J527- final control diagnosis

- Connect the vehicle diagnosis, testing and information system -VAS 5051A- to ⇒ [page 281](#)
- Select "guided fault finding" in Vehicle Diagnosis, Testing and Information System -VAS 5051A- .
- Using the "Go to" key, select "Function/component selection" and the following menu items one after the other:
 - ◆ Body
 - ◆ Electrical System
 - ◆ 01 - On Board Diagnostic capable systems
 - ◆ Steering wheel electronics
 - ◆ Steering wheel electronics functions



- ◆ Steering wheel electronics final control diagnosis

9.4 Steering angle sender -G85-

Removing and installing steering angle sender -G85-
[⇒ page 224](#)

9.4.1 Basic setting steering angle sender -G85-

- Connect the vehicle diagnosis, testing and information system -VAS 5051A- to [⇒ page 281](#)
- Select “guided fault finding” in Vehicle Diagnosis, Testing and Information System -VAS 5051A- .
- Using the “Go to” key, select “Function/component selection” and the following menu items one after the other:
 - ◆ Running gear
 - ◆ Brake system
 - ◆ 01 - Mark 60/Mark 70 systems, capable of self-diagnosis
 - ◆ Anti-lock braking system ABS/EDL/TCS/ESP Mark 60
 - ◆ Function
 - ◆ Basic setting steering angle sensor (00778-3132) -G85-





10 Ignition switch and lock cylinder

10.1 Removing and installing steering lock housing



Caution

Disconnecting and connecting the battery as described in the Workshop Manual ⇒ [page 29](#) .



Note

To remove steering lock housing it is necessary to remove the steering column switch base first.



Caution

- ◆ *The steering lock could be destroyed.*
- ◆ *If the steering lock is actuated without lock cylinder, it will block and must be renewed.*
- ◆ *The steering lock must not be actuated without lock cylinder.*

Removing:

- Disconnect the battery ⇒ [page 29](#) .
- Remove basic brace for steering column switch ⇒ [page 226](#)

10.2 Removing and installing lock cylinder



Caution

- ◆ *Disconnecting and connecting the battery as described in the Workshop Manual ⇒ [page 29](#) .*
- ◆ *The steering lock could be destroyed.*
- ◆ *If the steering lock is actuated without lock cylinder, it will block and must be renewed.*
- ◆ *The steering lock must not be actuated without lock cylinder.*

Removing:

- Disconnect the battery ⇒ [page 29](#) .
- Remove steering wheel ⇒ General body repairs, interior; Rep. Gr. 69 ; Airbag; Removing and installing steering wheel .
- Remove steering column trim ⇒ General body repairs, interior; Rep. Gr. 68 ; Compartments, covers and trim; Removing and installing steering column switch trim .
- Remove steering column electronics control unit -J527- ⇒ [page 221](#) .



- Remove coil spring for airbag/coil connector with slip ring - F138- ➔ [page 223](#) .
- Remove steering angle sender -G85- ➔ [page 224](#) .



Note

- ◆ For reasons of clarity, the diagram is shown without turn signal and windscreen wiper switch. There is no need to remove the switches for removal of the lock cylinder.
 - ◆ The immobilizer reader coil is secured to the lock cylinder and cannot be replaced individually.
- Disconnect connector -arrow- at reader coil.

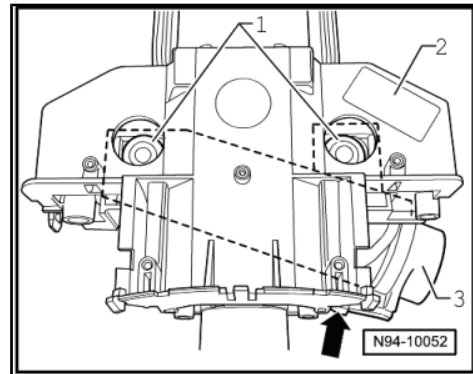

- Insert ignition key in lock cylinder and turn to position "Drive".

Position of key in lock cylinder:

- 1 - Position "Stop"
- 2 - Position "Drive"
- 3 - Position "Start"

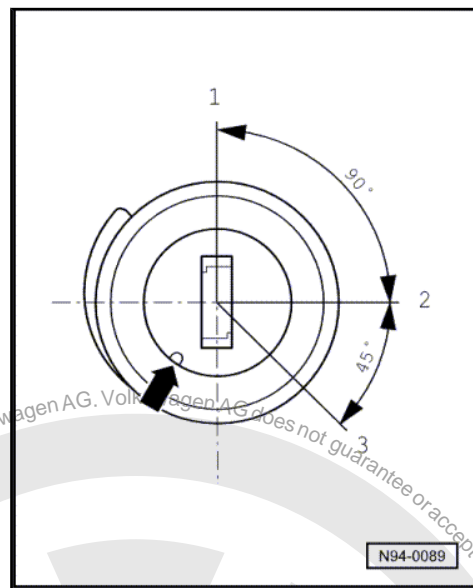

Note

For reasons of clarity, the diagram shows a removed lock cylinder without ignition key.

- Insert steel rod (approx. Ø 1.2 mm) in drilling -arrow- adjacent to ignition key.
- Using steel rod -2- disengage -arrow- safety bar -3- of lock cylinder -1-.
- Pull lock cylinder -1- out of steering lock housing.

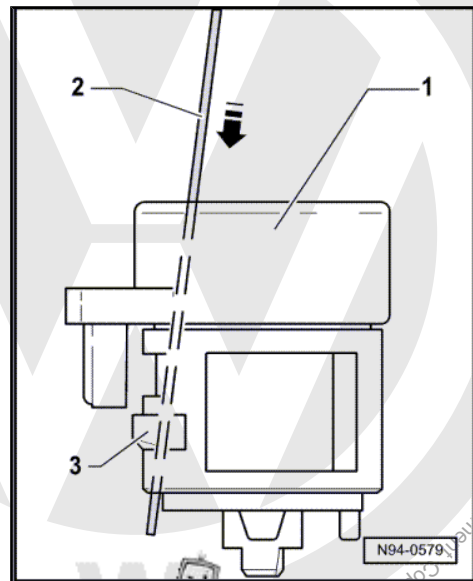



Installing:



Note

For reasons of clarity, the ignition key is not shown in the following diagram.

- Insert ignition key in lock cylinder -1- and turn to position "Drive".
- Using steel rod -2- disengage -arrow- safety bar -3- of lock cylinder -1-.
- Place lock cylinder -1- in steering lock housing.

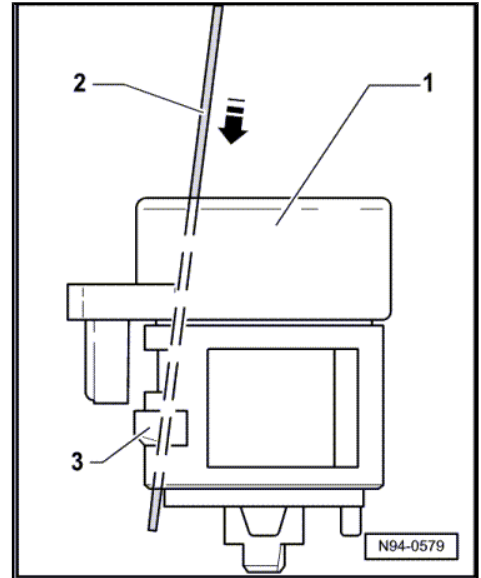

Note

The connection for the immobilizer reader coil must be inserted in the steering lock housing guide.

- Pull steel rod -2- out of lock cylinder -1- and check lock cylinder is seated correctly in the steering lock housing.
- Fit connector to immobilizer reader coil.
- Install all parts in reverse order of removal.

10.3 Removing and installing ignition switch



Caution

Disconnecting and connecting the battery as described in the Workshop Manual => page 29 .

Removing:

- Disconnect the battery => [page 29](#) .
- Pull connector -2- off ignition switch -1-.
- Release ignition switch using small screwdriver -arrows-.
- Pull ignition switch -1- out of steering lock housing.

Installing:

- Insert ignition switch in steering lock housing until it can be heard to engage.

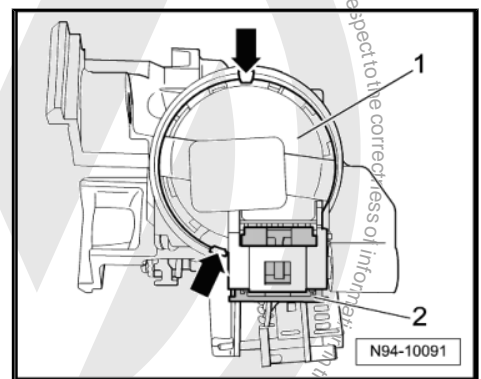



- Insert ignition key in lock cylinder and turn to position "Drive".



Note

Insert ignition key in lock cylinder and turn to position "Drive".

Position of key in lock cylinder:

- 1 - Position "Stop"
 - 2 - Position "Drive"
 - 3 - Position "Start"
- Install all parts in reverse order of removal.

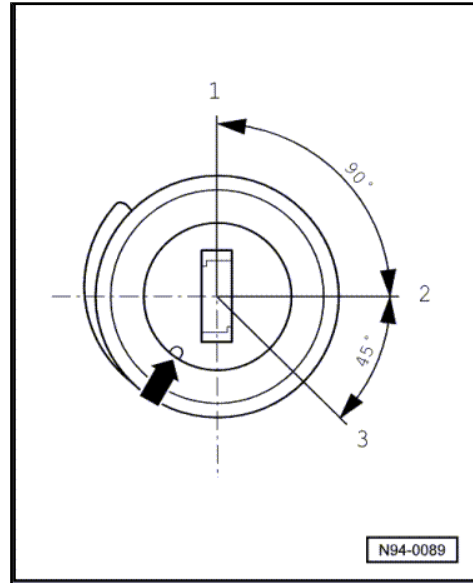

10.3.1 Removing and installing ignition key withdrawal lock solenoid -N334-

The ignition key withdrawal lock solenoid -N334- is located directly adjacent to the ignition starter key.



Note

To remove ignition key on vehicles with an automatic gearbox, always move selector lever to position "P" first then switch off ignition. Otherwise the ignition key withdrawal lock solenoid -N334- will inhibit the removal of the ignition key.

Removing:

- Remove steering column electronics control unit -J527- => [page 221](#) .
- Release locking device -2- using a screwdriver.
- Pull ignition key withdrawal lock solenoid -N334- -1- in direction of arrow and out of its mounting.
- The electrical connection will be disconnected automatically.

Installing:

- Installation is performed in the reverse order of installation; when doing this, note the following:



Note

After reconnecting the battery, carry out final control diagnosis to activate ignition key withdrawal lock solenoid -N334- => [page 227](#) .

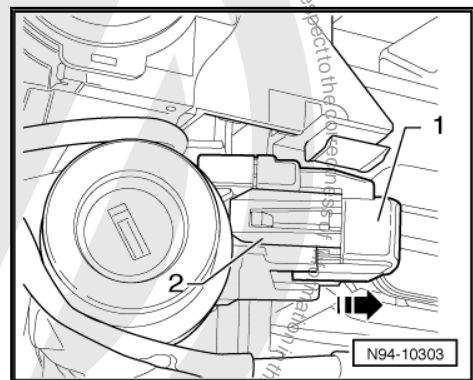



11 Parking aid



Note

- ◆ For complaints with the parking aid system it is absolutely essential to understand the function and operation of the system.
- ◆ Additional information ⇒ *Operating instructions*

General description:

The parking aid system or PDC (Park Distance Control) supports the driver during parking maneuvers by indicating the distance from the rear of the vehicle to the obstacle by way of acoustic signals.

The parking aid system comprises:

- ◆ Parking aid control unit -J446-
- ◆ Rear parking aid warning buzzer -H15-
- ◆ Rear left centre parking aid sensor -G204-
- ◆ Rear left inner parking aid sensor -G334-
- ◆ Rear right inner parking aid sensor -G335-
- ◆ Rear centre right parking aid sender -G205-

Fault detection and fault display:

The parking aid system is equipped with self-diagnosis, which is designed to simplify fault finding.

For fault finding, use the vehicle diagnosis, testing and information system -VAS 5051A- in "guided fault finding" mode.

To check the entire parking aid system, perform final control diagnosis ⇒ [page 236](#) .



11.1 Assembly overview - parking aid

1 - Parking aid system warning buzzer -H15-

- Below the rear shelf
- Removing and installing
⇒ [page 236](#)

2 - Parking aid control unit - J446-

- Behind right luggage compartment trim panel
- Removing and installing
⇒ [page 234](#)

3 - Rear centre right parking aid sender -G205-

- In the rear bumper cover
- Removing and installing
⇒ [page 235](#)

4 - Rear right inner parking aid sensor -G335-

- In the rear bumper cover
- Removing and installing
⇒ [page 235](#)

5 - Rear left inner parking aid sensor -G334-

- In the rear bumper cover
- Removing and installing
⇒ [page 235](#)

6 - Rear centre left parking aid sender -G204-

- In the rear bumper cover
- Removing and installing
⇒ [page 235](#)

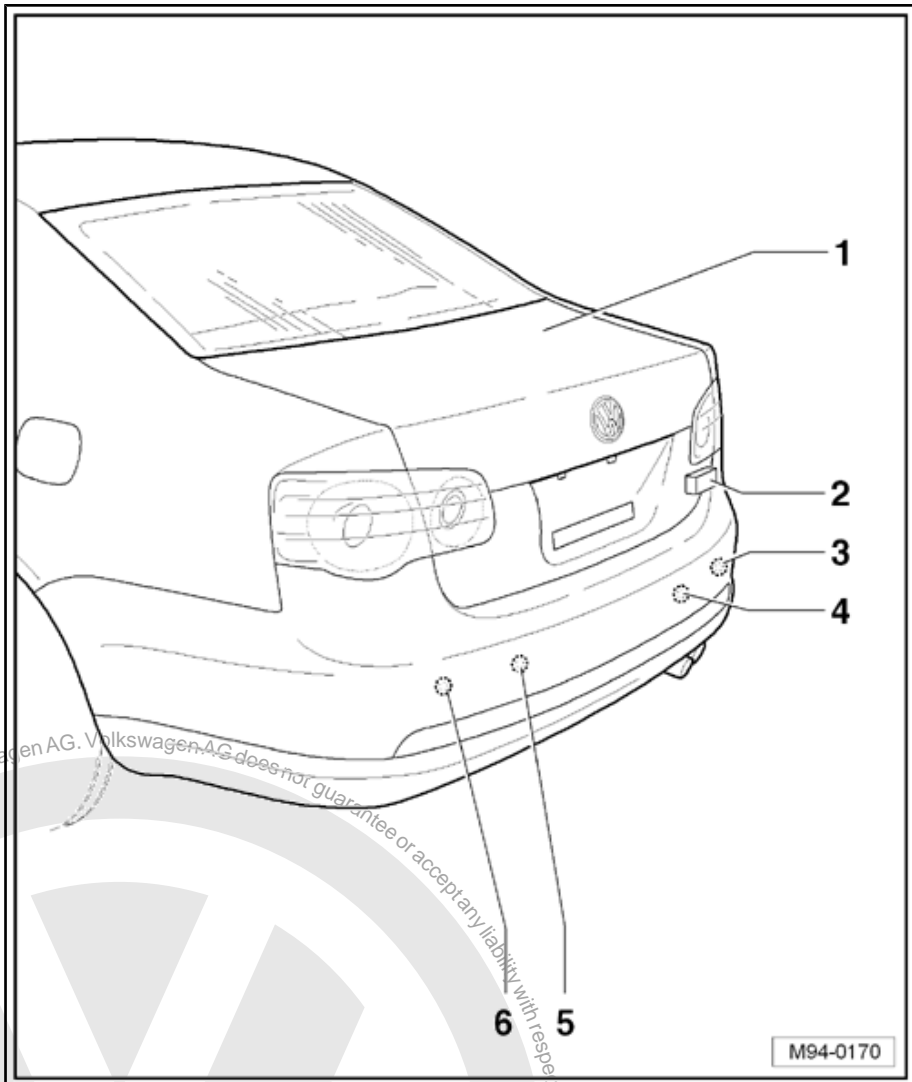

11.2 Removing and installing parking aid control unit -J446-

The parking aid control unit is located behind the right luggage compartment panel trim.

Removing:

- Switch off ignition and all electrical consumers and pull out ignition key.
- Remove right side panel trim in luggage compartment ⇒ General body repairs, interior; Rep. Gr. 70 ; Load and luggage area trims.



- Remove connectors -1- by pressing the locking tabs -arrows- inwards.

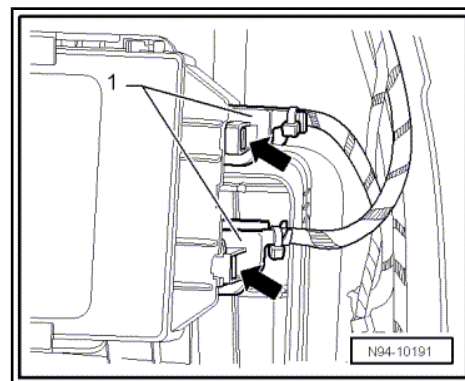

- Press locking tabs -arrows- of the retainer outwards and take parking aid control unit -1- out of the retainer.

Installing:

Install in reverse order of removal.

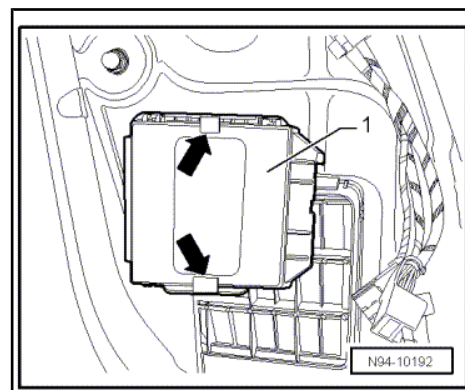

11.3 Removing and installing parking aid sensor

Following 4 senders are located in the rear bumper cover.

- ◆ Rear centre left parking aid sender -G204-
- ◆ Rear left inner parking aid sensor -G334-
- ◆ Rear right inner parking aid sensor -G335-
- ◆ Rear centre right parking aid sender -G205-



Note

Removal and installation of the rear parking aid sensor is carried out in the same way for all sensors and is described below for just one sensor.

Removing:

- Switch off ignition and all electrical consumers and pull out ignition key.
- Remove rear bumper cover ⇒ General body repairs, exterior; Rep. Gr. 63; Rear bumper .

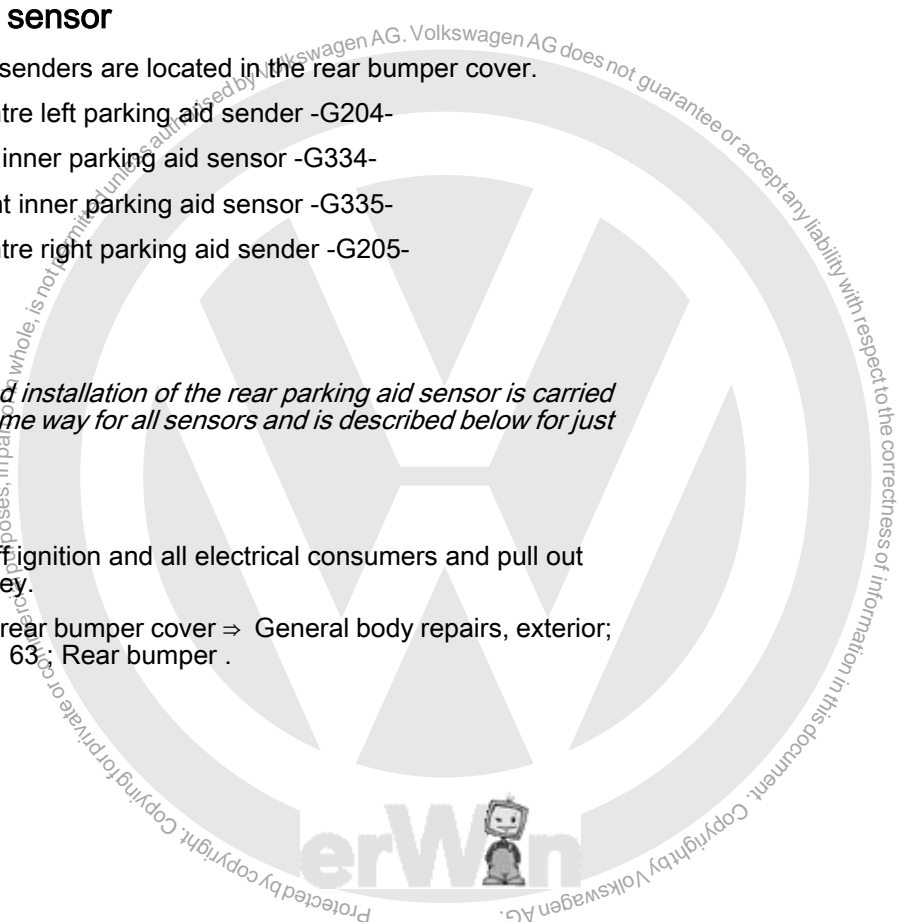



- Disconnect connector -arrow-.

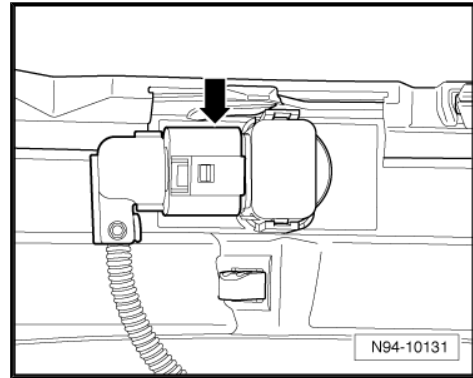

- Release locking lugs -arrows- and pull sender out of bumper cover.

Installing:

Install in reverse order of removal.

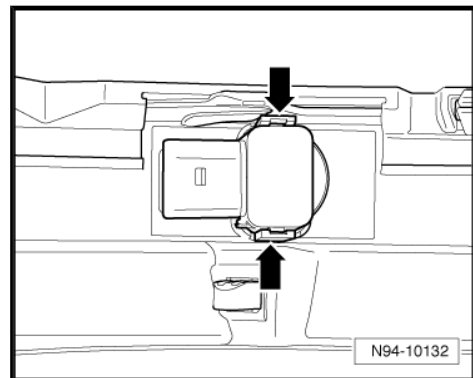

11.4 Removing and installing rear parking aid warning buzzer -H15-

The rear parking aid warning buzzer -H15- is fitted on the rear shelf plate. It is accessible via the luggage compartment.

Removing:

- Pull off connector -1-.
- Release securing clips -arrows- remove rear parking aid warning buzzer -H15- from retainer.

Installing:

Install in reverse order of removal.

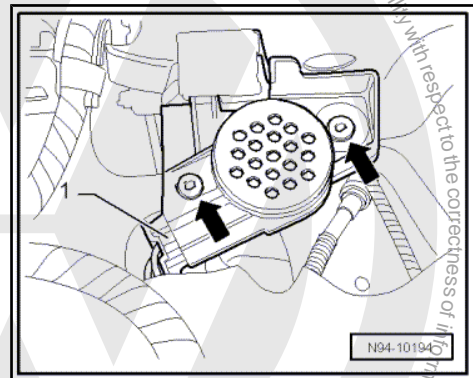

11.5 Final control diagnosis

- Connect the vehicle diagnosis, testing and information system -VAS 5051A- to [page 281](#)
- Select "guided fault finding" in Vehicle Diagnosis, Testing and Information System -VAS 5051A- .
- Using the "Go to" key, select "Function/component selection" and the following menu items one after the other:
 - ◆ Body
 - ◆ General Body Repairs
 - ◆ 01 - On Board Diagnostic capable systems
 - ◆ Parking aid



- ◆ Parking aid functions
- ◆ Final control diagnosis





12 Torque settings: lights, bulbs, switches - exterior

12.1 Torque settings: headlight

Threaded connections	Torque settings
Upper headlight	4 Nm
Lower left headlight	4 Nm
Lower right headlight	4 Nm

12.2 Torque settings: fog lights

Threaded connections	Torque settings
Headlight securing screws	1,5 Nm

12.3 Torque settings - tail light in side panel

Threaded connections	Torque settings
Securing nuts	3.5 Nm \pm 0.5 Nm

12.4 Torque settings - tail light in tailgate

Threaded connections	Torque settings
Securing nuts	3.5 Nm \pm 0.5 Nm

12.5 Torque settings: vehicle level sender

Threaded connections		Torque settings
Front left vehicle level sender -G78-	M6	9 Nm
Rear left vehicle level sender -G76-	M5	5 Nm

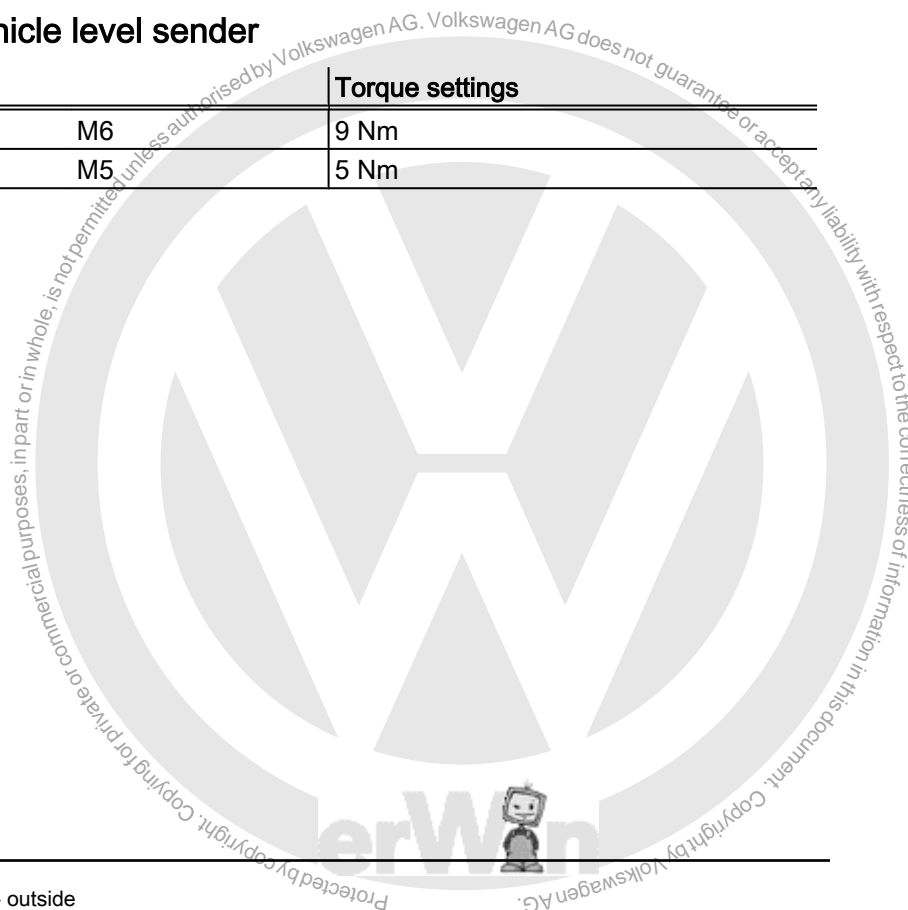



96 – Lights, lamps, switches - inside

1 Lights and switches in engine compartment



Note

The Jetta or the Bora have no lights in the engine compartment.

1.1 Removing and installing bonnet contact switch -F266-



Note

- ◆ *The bonnet contact switch -F266- is integrated into the bonnet lock and cannot be replaced individually.*
- ◆ *If the bonnet contact switch -F266- is found to be defective, the entire bonnet lock must always be replaced.*
- Remove front bonnet lock → General Body Repairs, Exterior; Rep. Gr. 55 ; Bonnet; Removing and installing coupling lock; Removing .



2 Lights and switches in dash panel

2.1 Removing and installing light switch - E1-

The following components are integrated into the light switch - E1- :

- ◆ Fog light switch -E7-
- ◆ Rear fog light switch -E18-
- ◆ Light switch illumination bulb -L9-

Removing:

- Switch off the ignition and all electrical consumers.
- Turn grip of light switch to position "0".
- Push in grip of light switch -1- and turn it to the right slightly -2-.
- Hold rotary part in this position and pull lighting switch (using rotary part) out of dash panel -3-.

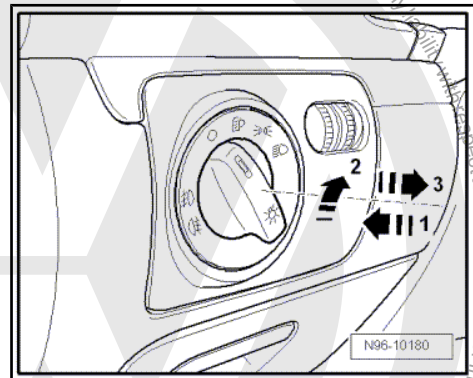

- Disconnect connector -arrow-.

Installing:

- Fit connector to light switch.

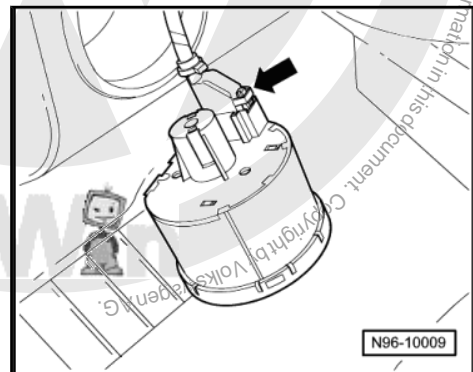

- Hold light switch and press rotary position indicator of light switch firmly inwards -1- and turn slightly to right -2-.
- Hold grip in this position and insert light switch in dash panel -3-.
- Turn rotary knob to "0" release and engage switch.

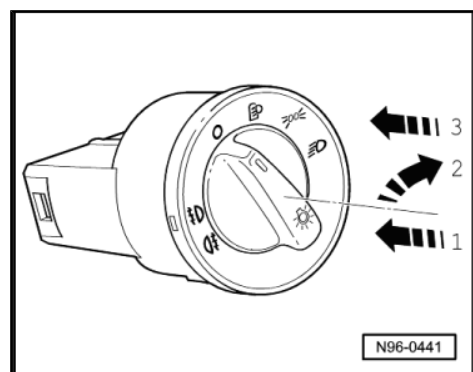



2.2 Removing and installing glove compartment light -W6-

Special tools and workshop equipment required

- ◆ Removal wedge -VAS 3409-

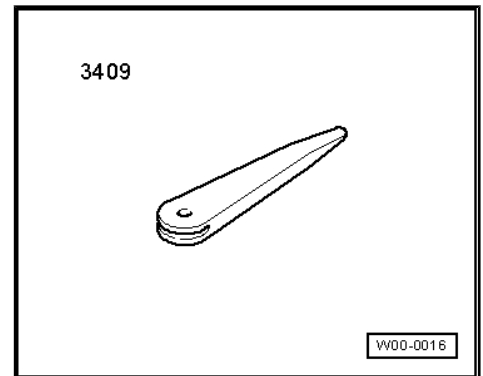

Note

When removing and installing components in visual area (connectors, covers, trims etc.) apply a commercial adhesive tape where a lever tool is applied (removal wedge -VAS 3409-, screwdriver).

Removing:

- Switch off the ignition and all electrical consumers.
- Lever lens carefully out using removal wedge -VAS 3409- or a screwdriver.

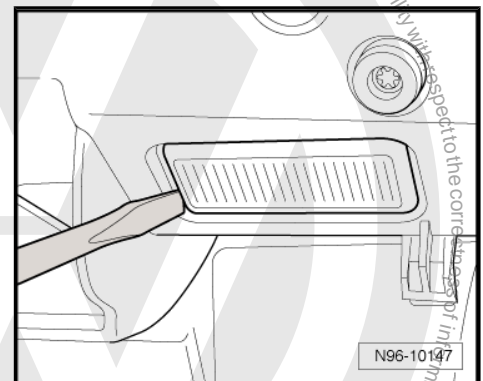

- Disconnect connector -arrow-.

Renew bulb:

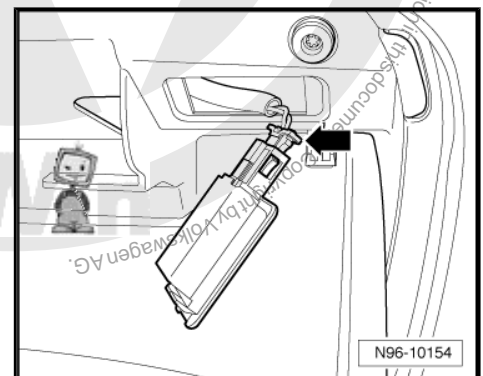



- Unlock locking tabs -1- and take thermal protection plate -2- off the lens or the light.

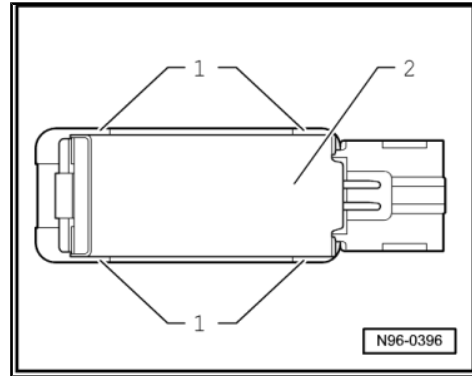

- Lever bulb carefully out of the holder.
- Renew glass base bulb (12 V, 5 W).

Installing:

Installation is carried out in the reverse order. When installing, note the following:

- Check functions of glove box switch. The lamp must not light when the lid is closed.

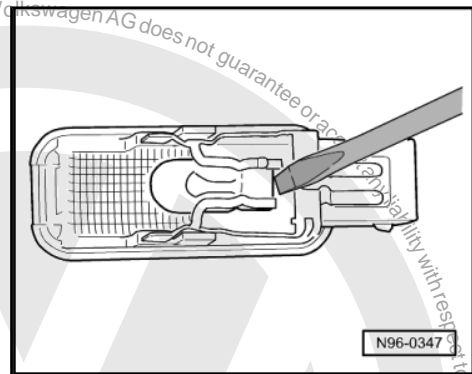

2.3 Removing and installing glove compartment light switch -E26-

The glove compartment light switch can be found on the rear of the glove compartment.

Removing:

- Switch off the ignition and all electrical consumers.
- Remove glove compartment → General body repairs, interior; Rep. Gr. 68 ; Compartments, covers and trim; Removing and installing glove compartment .
- Unlock locking lug -1- and slide the switch out of the guide -arrow-.

Installing:

Install in reverse order of removal.

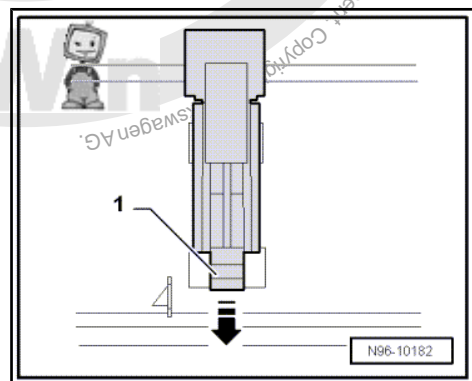

2.4 Removing and installing switches and instruments illumination regulator -E20-

Removing:

- Switch off the ignition and all electrical consumers.
- Remove light switch ⇒ [page 240](#) .
- Remove storage compartment on driver side → General body repairs, interior; Rep. Gr. 68 ; Compartments, covers and trim .



- Disconnect connector -arrow-.

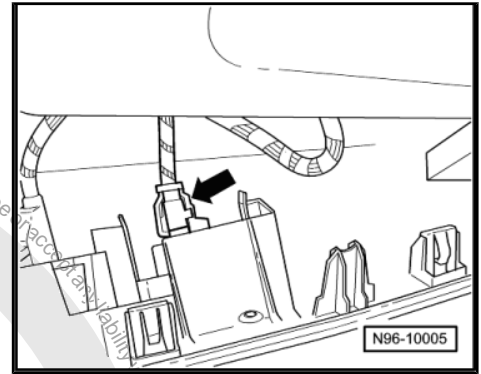

- Unlock locking lugs -arrows- and take adjuster and regulator out.

Installing:

Install in reverse order of removal.

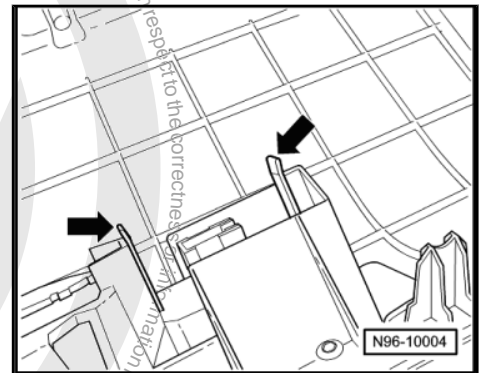

2.5 Removing and installing front passenger side airbag deactivated warning lamp - K145-

Removing:

- Switch off the ignition and all electrical consumers.
- Remove centre vent ⇒ Heating, air conditioning system; Rep. Gr. 80 ; Servicing heating system; remove vent; Remove centre vent .
- Remove connectors -arrows-.

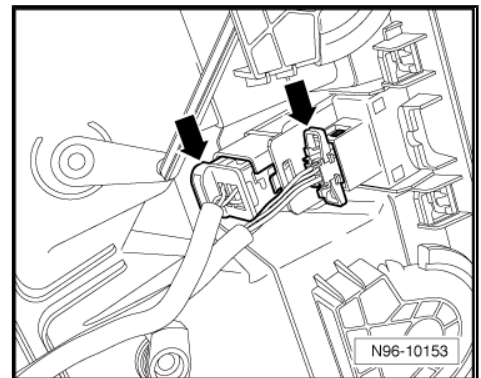



- Unlock locking lugs -arrows- and take warning lamp out.

Installing:

Install in reverse order of removal.

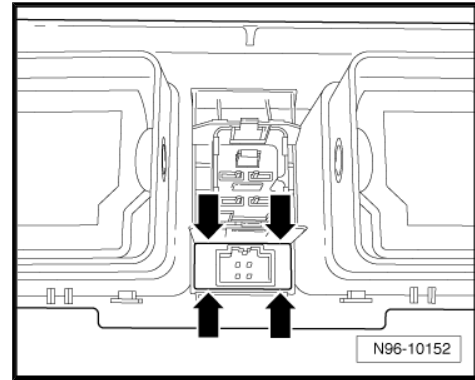

2.6 Removing and installing hazard warning light switch -E3-

Removing:

- Switch off the ignition and all electrical consumers.
- Remove centre vent → Heating, air conditioning system; Rep. Gr. 80 ; Servicing heating system; remove vent; Remove centre vent .
- Remove connectors -arrows-.

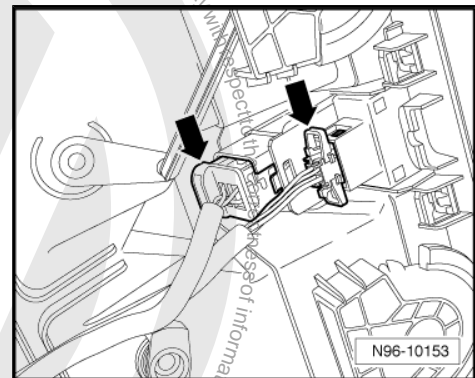

- Release locking lugs -arrows- and remove hazard warning light switch.

Installing:

Install in reverse order of removal.

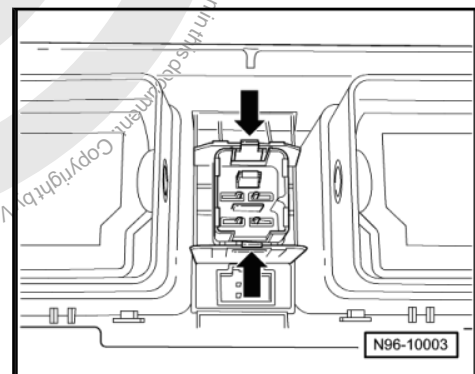

2.7 Removing and installing left footwell light -W9- and right footwell light -W10-

Special tools and workshop equipment required



◆ Removal wedge -VAS 3409-

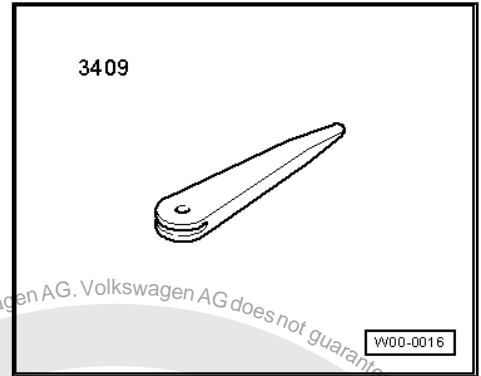

Note

- ◆ *When removing and installing components in visual area (connectors, covers, trims etc.) apply a commercial adhesive tape where a lever tool is applied (removal wedge -VAS 3409-, screwdriver).*
- ◆ *The removal and installation of both footwell lights is the same so that only one light is described.*

Removing:

- Switch off the ignition and all electrical consumers.
- Lever footwell light out of the trim under the dash panel using removal wedge -VAS 3409- or a screwdriver.

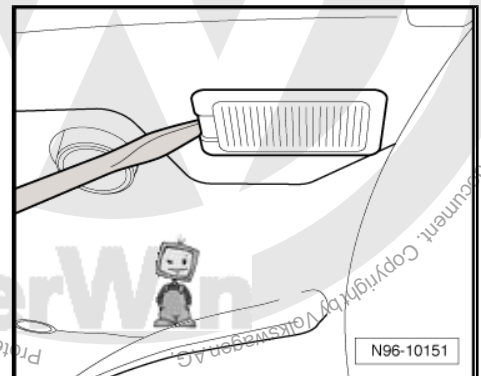

- Disconnect connector -arrow-.

Renew bulb:

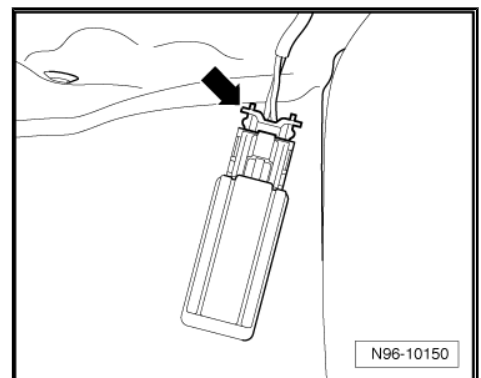



- Unlock locking tabs -1- and take thermal protection plate -2- off the lens or the light.

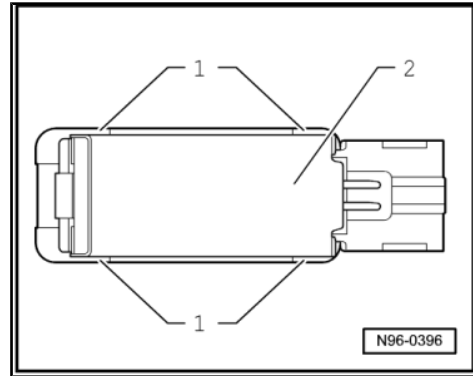

- Lever bulb carefully out of the holder.
- Renew glass base bulb (12 V, 5 W).

Installing:

Install in reverse order of removal.

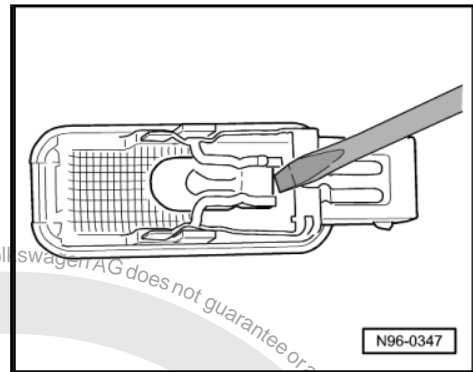

2.8 Removing and installing key operated switch to deactivate front passenger side airbag -E224-



WARNING

Observe safety measures when working on airbag → General body repairs, interior; Rep. Gr. 69 ; Safety measures when working on airbags .

Removing:

- Switch off the ignition and all electrical consumers.
- Remove glove compartment → General body repairs, interior; Rep. Gr. 68 ; Compartments, covers and trim; Removing and installing glove compartment .
- Disconnect connector -arrow-.

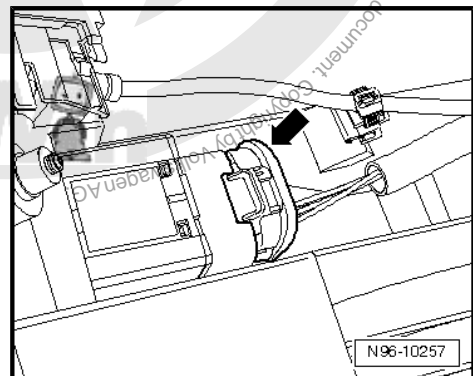



- Release locking lugs -arrows- and remove key switch.

Installing:

Install in reverse order of removal.

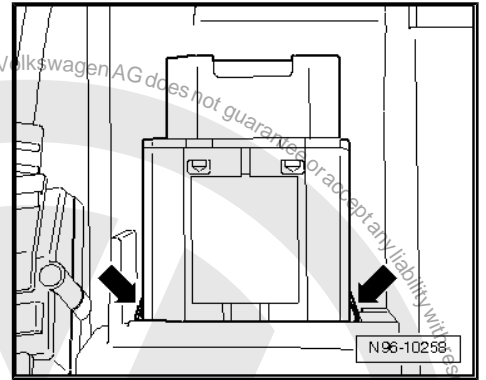

Protected by copyright. Copying for private or commercial purposes, in part or in whole, is not permitted unless authorised by Volkswagen AG. Volkswagen AG does not guarantee or accept any liability with respect to the correctness of information in this document. Copyright by Volkswagen AG.



3 Lights and switches in front doors

3.1 Removing and installing window regulator switch in front passenger door - E107-



Note

The window regulator switch in front passenger door -E107- features a button illumination bulb -L76-, which must not be replaced individually.

Removing:

- Switch off the ignition and all electrical consumers.
- Remove lever shell, upper part out of the closing lever ⇒ General body repairs, interior; Rep. Gr. 70 ; Removing and installing door trim; Front door trim, front passenger side .
- Disconnect connector -arrow-.

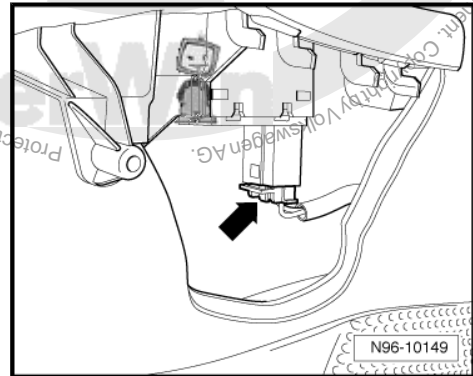

- Release locking lugs -arrows- and remove switch from the installation frame.

Installing:

Install in reverse order of removal.

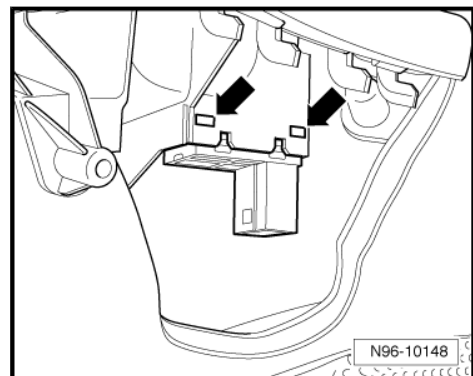

3.2 Removing and installing switch module for driver side mirror adjustment

The following components (depending on equipment) are integrated into the switch module for the driver side mirror adjustment:

- ◆ Mirror adjustment switch -E43-
- ◆ Mirror adjustment reversing switch -E48-
- ◆ Exterior mirror heater button -E231-
- ◆ Mirror fold-in feature system switch -E263-
- ◆ Mirror adjustment switch illumination bulb -L78-



i Note

In the event of repair, the complete component must be renewed.

Removing:

- Remove switch module window lifter, driver side
⇒ [page 250](#) .
- Unclip installation frame for switch from trim.
- Release locking lugs -arrows- and remove switch from the installation frame.

Installing:

Install in reverse order of removal.

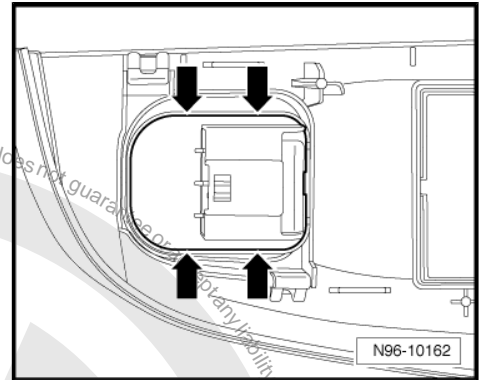

3.3 Removing and installing driver side interior locking button for central locking system -E308-

i Note

The driver side interior locking button for central locking system -E308- features a button illumination bulb -L76- , which must not be replaced individually.

Removing:

- Switch off the ignition and all electrical consumers.
- Remove door trim ⇒ General body repairs, interior; Rep. Gr. 70 ; Removing and installing front door trim, driver side .
- Disconnect connector -1- and tighten securing bolts -2-.
- Take door opener with switch out of the door trim.

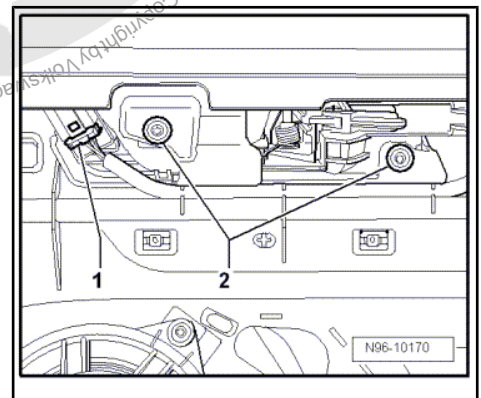



- Release locking lugs -arrows- and remove interior locking switch from the installation frame.

Installing:

Install in reverse order of removal.

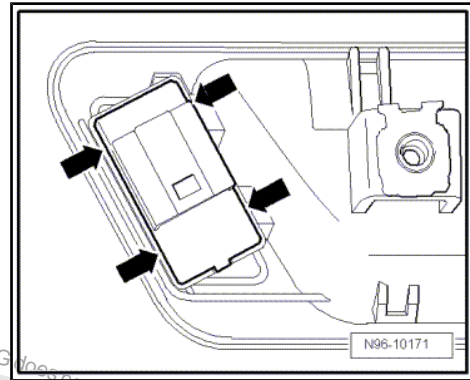

3.4 Components - front door locks

The following components (depending on equipment) are integrated into the driver side door lock:

- ◆ Driver door contact switch -F2-
- ◆ Driver side central locking lock unit -F220-
- ◆ Driver door central locking motor -V56-
- ◆ Driver door central locking deadlock function motor -V161-

The following components (depending on equipment) are integrated into the passenger side door lock:

- ◆ Front passenger door contact switch -F3-
- ◆ Front passenger side central locking lock unit -F221-
- ◆ Front passenger seat central locking motor -V57-
- ◆ Front passenger door central locking deadlock function motor -V162-



Note

In the event of repair, the complete component must be renewed.

In the event of component defects - front door locks:

- Replace relevant door lock ⇒ General Body Repairs, Exterior; Rep. Gr. 57 ; Front door; Removing and installing door lock .

3.5 Removing and installing switch module for driver side window lift

Special tools and workshop equipment required

- ◆ Removal wedge -VAS 3409-

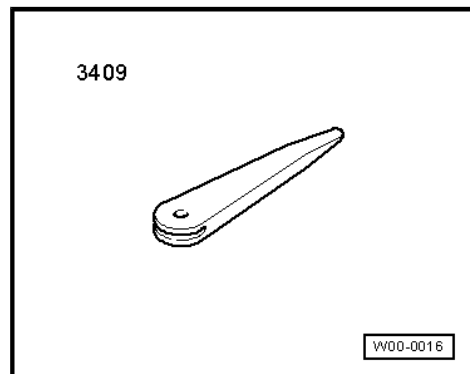



i Note

When removing and installing components in visual area (connectors, covers, trims etc.) apply a commercial adhesive tape where a lever tool is applied (removal wedge -VAS 3409- , screwdriver).

The following components (in models with 4 doors) are integrated into the switch module for the driver side window lift:

- ◆ Front left window regulator switch -E40-
- ◆ Rear left window regulator switch, in driver door -E53-
- ◆ Rear right window regulator switch, in driver door -E55-
- ◆ Front right window regulator switch in driver door -E81-
- ◆ Childproof lock button -E318-
- ◆ Button illumination bulb -L76-

i Note

In the event of repair, the complete component must be renewed.

The following components (in models with 2 doors) are integrated into the switch module for the driver side window lift:

- ◆ Front left window regulator switch -E40-
- ◆ Front right window regulator switch in driver door -E81-
- ◆ Button illumination bulb -L76-

i Note

In the event of repair, the complete component must be renewed.

Removing:

- Switch off the ignition and all electrical consumers.
- Carefully lever installation frame out of door trim using removal wedge -VAS 3409- or screwdriver -arrow-.

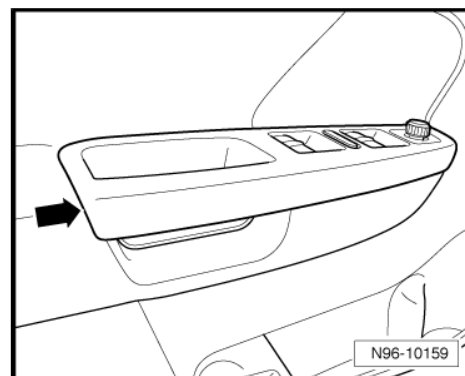



- Remove connectors -arrows-.

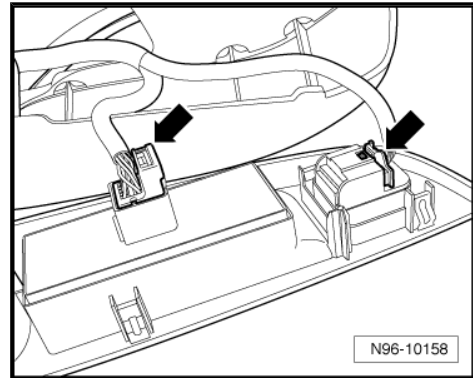

- Release locking lugs -arrows- and remove switch from the installation frame.

Installing:

Install in reverse order of removal.

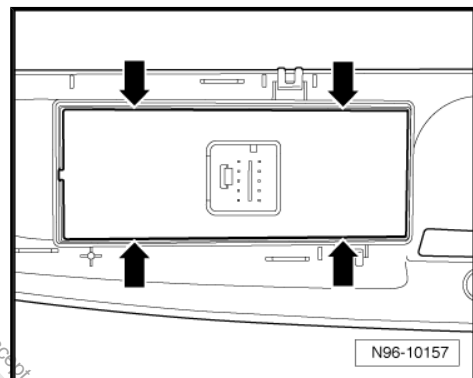

3.6 Removing and installing remote release button for fuel filler flap and rear lid -E463- and key operated switch to block release of rear lid remote -E232-



Note

The remote release button for fuel filler flap and rear lid -E463- features a button illumination bulb -L76-, which must not be replaced individually.

Removing:

- Switch off the ignition and all electrical consumers.
- Remove door trim => General body repairs, interior; Rep. Gr. 70 ; Door trim; Removing and installing front door trim, driver side .
- Disconnect connector -arrow-.

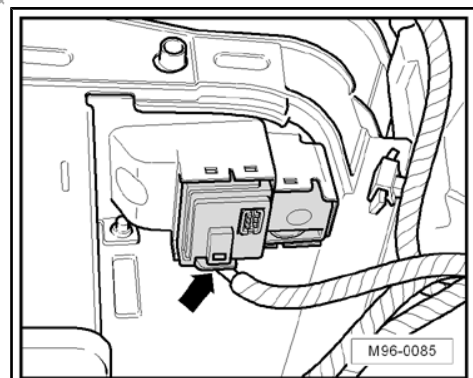



- Release locking lugs -arrows- and remove switch from the door trim.

Installing:

Install in reverse order of removal.

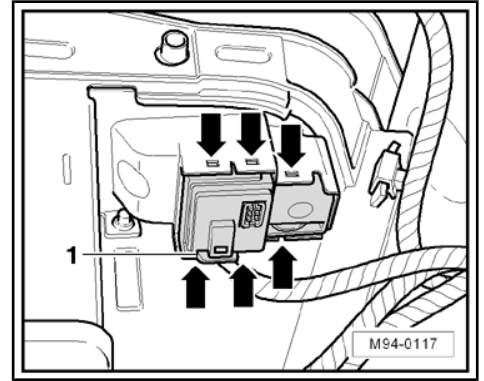



4 Lights and switches in rear doors

4.1 Components - front door locks

The following components (depending on equipment) are integrated into the rear left door lock:

- ◆ Rear left door contact switch -F10-
- ◆ Rear left central locking lock unit -F222-
- ◆ Rear left door central locking motor, lock -V214-
- ◆ Rear left door central locking deadlock function motor -V163-

The following components (depending on equipment) are integrated into the rear right door lock:

- ◆ Rear right door contact switch -F11-
- ◆ Rear right central locking lock unit -F223-
- ◆ Rear right door central locking motor, lock -V215-
- ◆ Rear right door central deadlock function locking motor -V164-



Note

In the event of repair, the complete component must be renewed.

In the event of component defects - rear door locks:

- Replace relevant door lock ⇒ General Body Repairs, Exterior; Rep. Gr. 58 ; Rear door; Removing and installing door lock .

4.2 Removing and installing rear left window regulator switch, in door -E52- and rear right window regulator switch, in door -E54-

Removing:

- Switch off the ignition and all electrical consumers.
- Remove lever shell, upper part out of the closing lever ⇒ General body repairs, interior; Rep. Gr. 70 ; Removing and installing door trim; Rear door trim .
- Disconnect connector -arrow-.

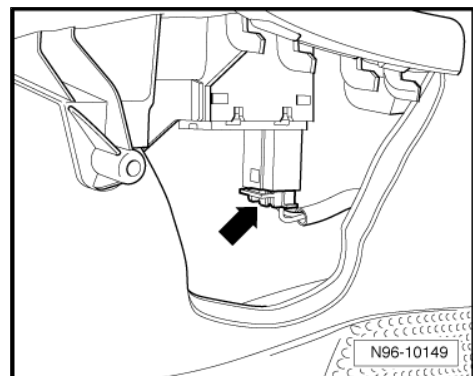



- Release locking lugs -arrows- and remove switch from the installation frame.

Installing:

Install in reverse order of removal.

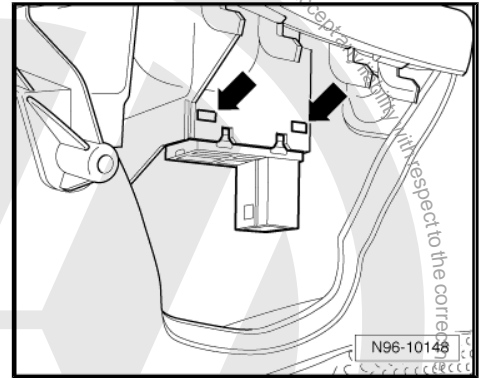



5 Lights and switches in luggage compartment

5.1 Removing and installing luggage compartment light -W3-

Special tools and workshop equipment required

- ◆ Removal wedge -VAS 3409-

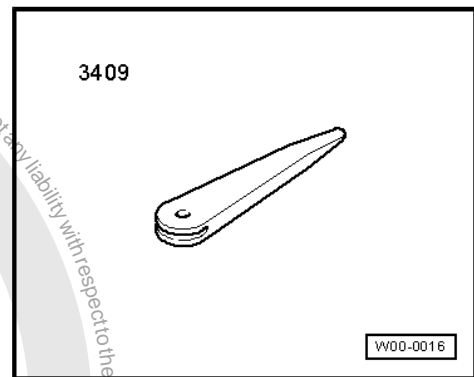

Note

- ◆ *The luggage compartment light can be found on the right side in the luggage compartment trim.*
- ◆ *When removing and installing components in visual area (connectors, covers, trims etc.) apply a commercial adhesive tape where a lever tool is applied (removal wedge -VAS 3409-, screwdriver).*

Removing:

- Switch off the ignition and all electrical consumers.
- Lever light out of the luggage compartment trim using removal wedge -VAS 3409- or a screwdriver.

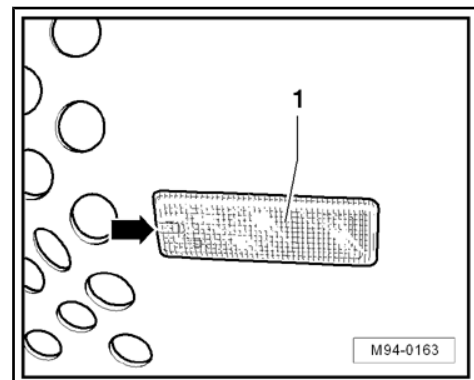



- Disconnect connector -arrow-.

Renew bulb:

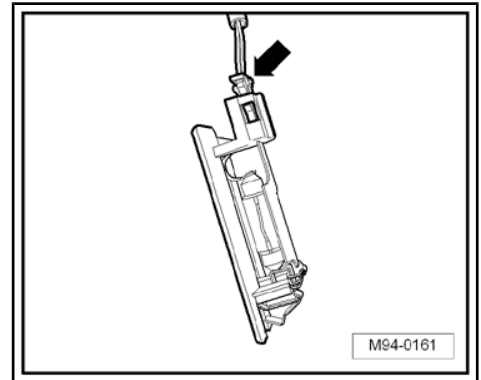

- Press contact plate -1- of the light outwards and take festoon bulb -2- out of the socket.
- Renew festoon bulb (12 V, 10 W).

Installing:

Install in reverse order of removal.

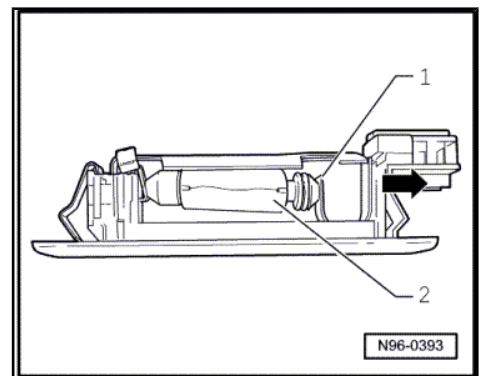

5.2 Removing and installing rear lid lock unit -F256-

The rear lid lock unit -F256- is integrated into the tailgate lock and cannot be replaced individually.

If the rear lid lock unit -F256- is found to be defective, the entire tailgate lock must always be replaced.

- Renew tailgate lock ⇒ General Body Repairs, Exterior; Rep. Gr. 55 ; Tailgate; Removing and installing coupling lock; Removing .





6 Lights and switches in roof trim

6.1 Removing and installing front interior light and reading light (vehicles with no sliding sunroof)

The following components are integrated in the interior light and reading light:

- ◆ Front interior light -W1-
- ◆ Left centre reading light -W39-
- ◆ Left centre reading light -W40-



Note

The interior light and reading light as well as the switches for the interior light and reading light are connected together and can not be separated. When repairing, renew the complete component.

6.1.1 Removing and installing front interior light and reading light

Special tools and workshop equipment required

- ◆ Removal wedge -VAS 3409-

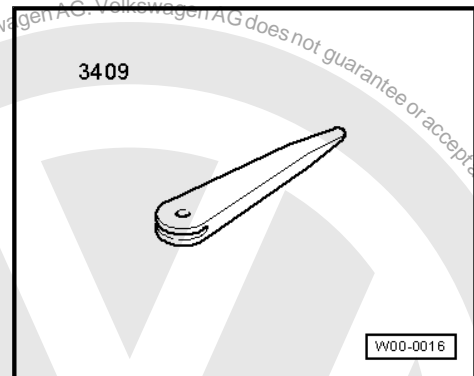

Note

When removing and installing components in visual area (connectors, covers, trims etc.) apply a commercial adhesive tape where a lever tool is applied (removal wedge -VAS 3409-, screwdriver).

Removing:

- Switch off the ignition and all electrical consumers.



- Carefully lever trim out of interior light using removal wedge -VAS 3409- or screwdriver -arrow-.

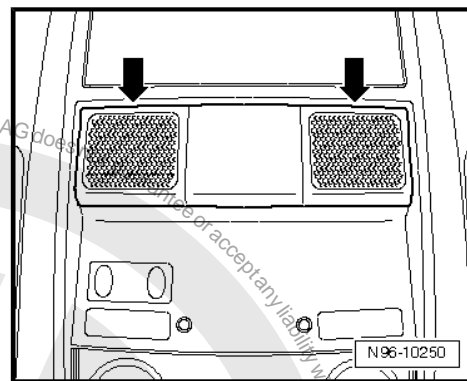

- Unbolt securing bolts -arrow-.
- Take the interior light out of the headliner console.

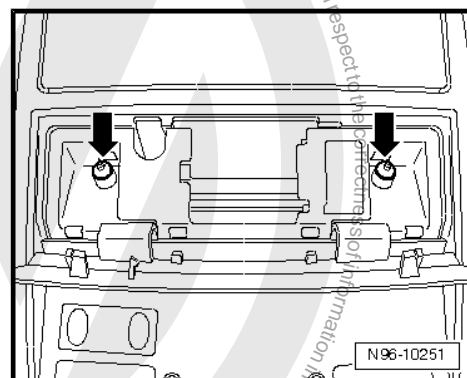

- Remove connectors -arrows-.

Installing:

Install in reverse order of removal.

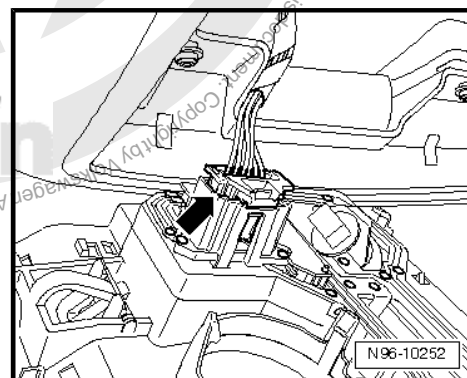

6.1.2 Replace front interior light -W1-

Special tools and workshop equipment required

- ◆ Removal wedge -VAS 3409-

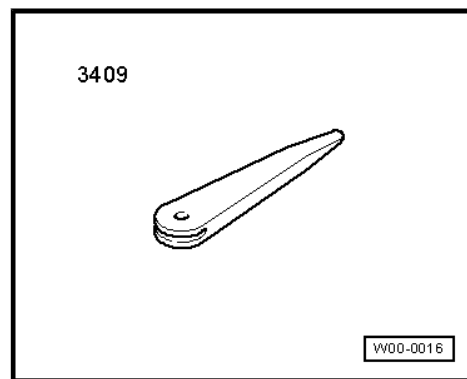



Note

When removing and installing components in visual area (connectors, covers, trims etc.) apply a commercial adhesive tape where a lever tool is applied (removal wedge -VAS 3409- , screwdriver).

Removing:

- Switch off the ignition and all electrical consumers.
- Carefully lever lens for interior light out using removal wedge -VAS 3409- or screwdriver -arrow-.

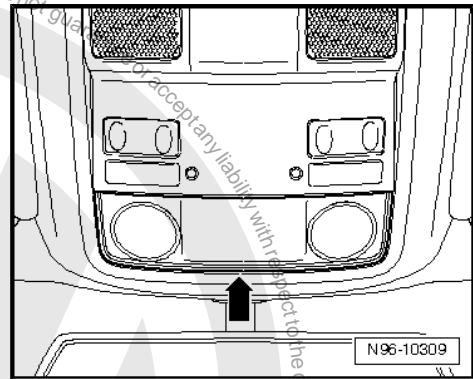

- Press contact -1- of light to side -arrow- and remove festoon bulb -2- with the contact from the interior light.

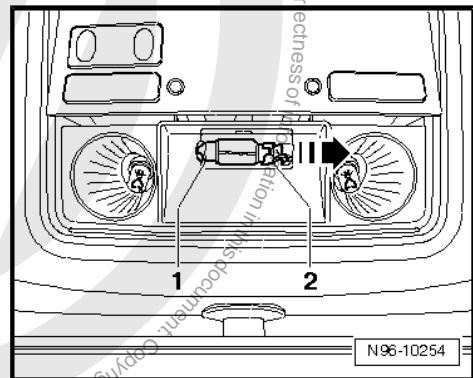

- Pull contact -arrow- off defective festoon bulb.
- Fit the contact to the new festoon bulb (12 V, 10 W).

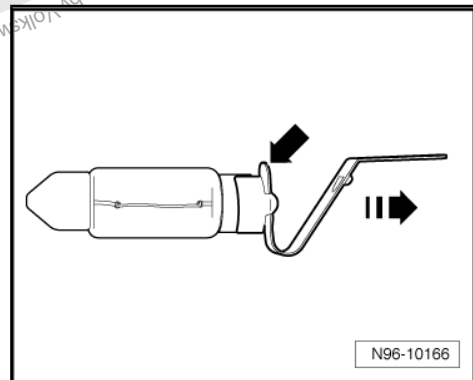

Installing:

Install in reverse order of removal.

6.1.3 Left centre reading light -W39- and right centre reading light -W40-

Removing:

- Remove interior light ⇒ [page 258](#) .



- Turn bulb holder -arrows- of the defective reading light for 90° to the left.
- Take the holder with the bulb out of the reading light.

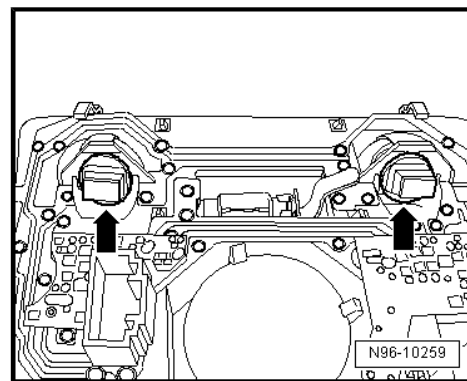

- Pull glass base bulb carefully out of the holder.
- Renew glass base bulb (12 V, 5 W).

Installing:

Install in reverse order of removal.

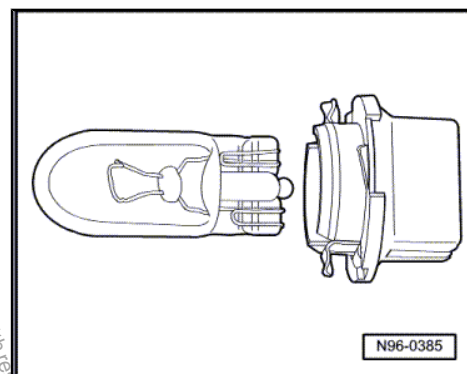

6.2 Removing and installing front interior light and reading light (vehicles with sliding sunroof)

The following components are integrated in the interior light and reading light:

- ◆ Front interior light -W1-
- ◆ Left centre reading light -W39-
- ◆ Left centre reading light -W40-
- ◆ Sunroof switch -E8-



Note

The interior light and reading light as well as the switches for the interior light and reading light are connected together and can not be separated. When repairing, renew the complete component.

6.2.1 Removing and installing front interior light and reading light

Special tools and workshop equipment required



◆ Removal wedge -VAS 3409-

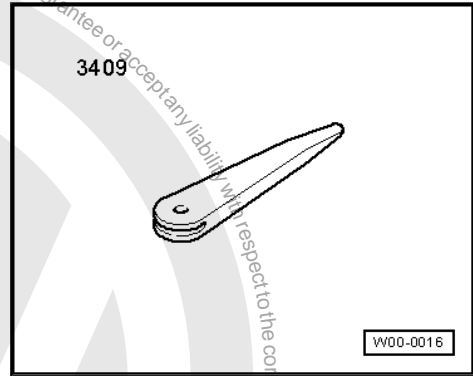

Note

When removing and installing components in visual area (connectors, covers, trims etc.) apply a commercial adhesive tape where a lever tool is applied (removal wedge -VAS 3409-, screwdriver).

Removing:

- Switch off the ignition and all electrical consumers.
- Carefully lever trim out of interior light using removal wedge -VAS 3409- or screwdriver -arrow-.

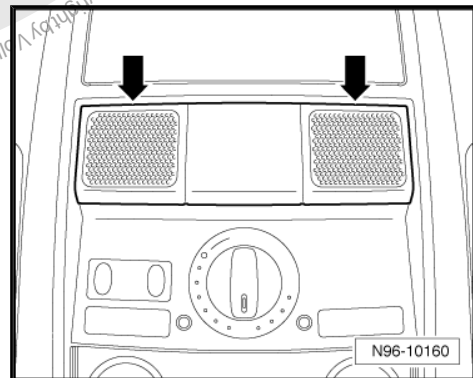

- Unbolt securing bolts -arrow-.
- Take the interior light out of the headliner console.

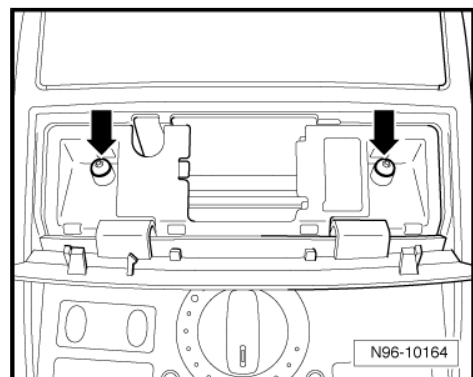



- Remove connectors -arrows-.

Installing:

Install in reverse order of removal.

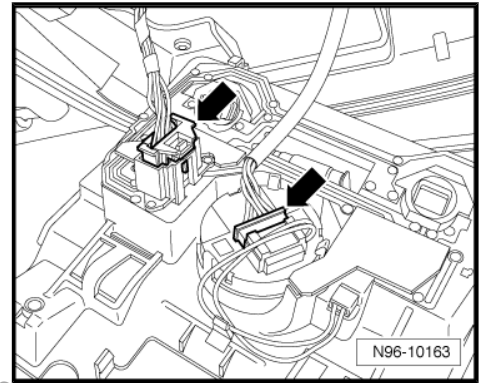

6.2.2 Removing and installing sunroof switch -E8-

Removing:

- Remove interior light => [page 261](#) .
- Disconnect connector -arrow-.

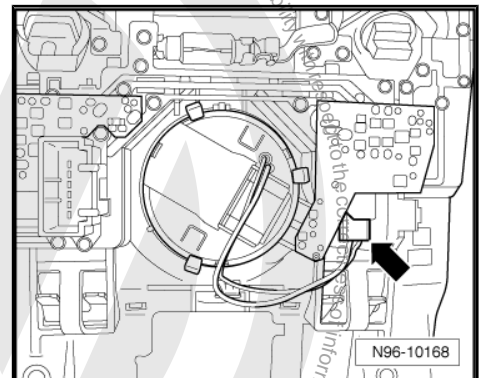

- Release locking lugs -arrows- and remove switch from the installation frame.

Installing:

Install in reverse order of removal.

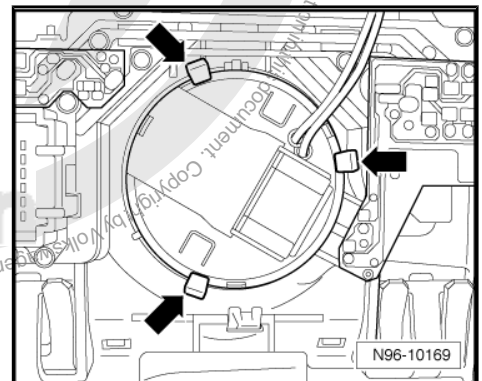

6.2.3 Replace front interior light -W1-

Special tools and workshop equipment required



◆ Removal wedge -VAS 3409-

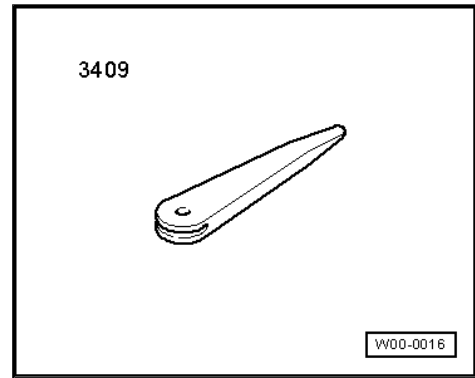

Note

When removing and installing components in visual area (connectors, covers, trims etc.) apply a commercial adhesive tape where a lever tool is applied (removal wedge -VAS 3409-, screwdriver).

Removing:

- Switch off the ignition and all electrical consumers.
- Carefully lever lens for interior light out using removal wedge -VAS 3409- or screwdriver arrow-

Press contact -1- of light to side -arrow- and remove festoon bulb -2- with the contact from the interior light.

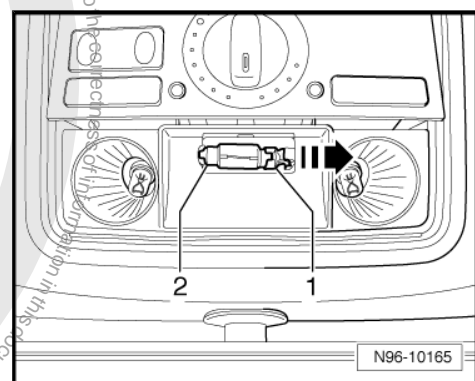
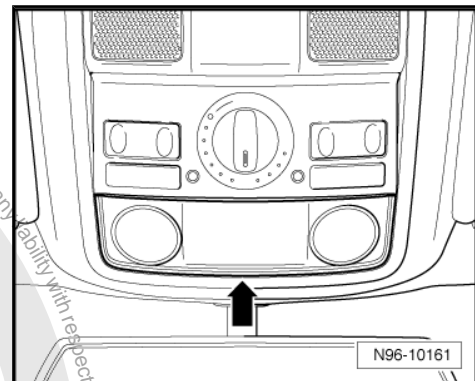



- Pull contact -arrow- off defective festoon bulb.
- Fit the contact to the new festoon bulb (12 V, 10 W).

Installing:

Install in reverse order of removal.

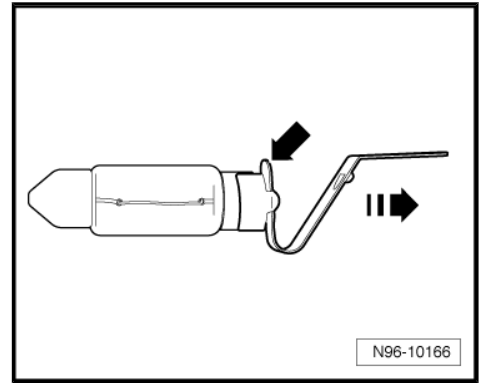

6.2.4 Left centre reading light -W39- and right centre reading light -W40-

Removing:

- Remove interior light => [page 261](#) .
- Turn bulb holder -arrows- of the defective reading light for 90° to the left.
- Take the holder with the bulb out of the reading light.

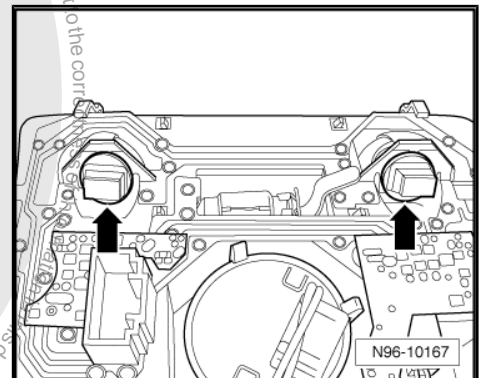

- Pull glass base bulb carefully out of the holder.
- Renew glass base bulb (12 V, 5 W).

Installing:

Install in reverse order of removal.

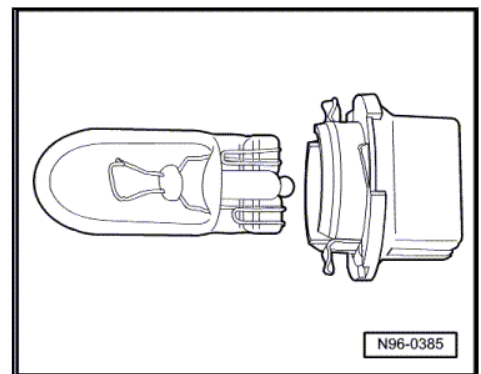

6.3 Rear interior and reading light (vehicles without ATAS)

The following components are integrated in the rear interior light and reading light:

- ◆ Rear left footwell light -W45-
- ◆ Rear left reading light -W11-
- ◆ Rear right reading light -W12-



Note

The interior light and reading light as well as the switches for the interior light and reading light are connected together and can not be separated. When repairing, renew the complete component.

6.3.1 Removing and installing rear interior and reading light (vehicles without ATAS)

Removing:

- Switch off the ignition and all electrical consumers.
- Release locking lugs -arrows- and take trim with lens off interior light and reading light.

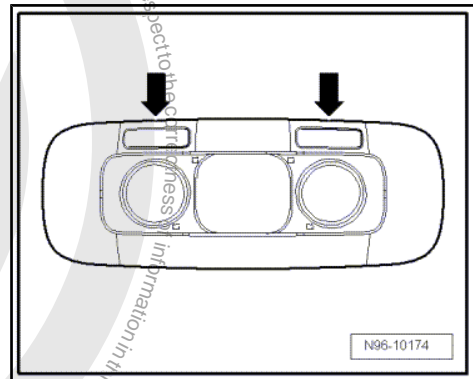

- Release locking lugs -arrows- and remove interior light and reading light from the headliner.

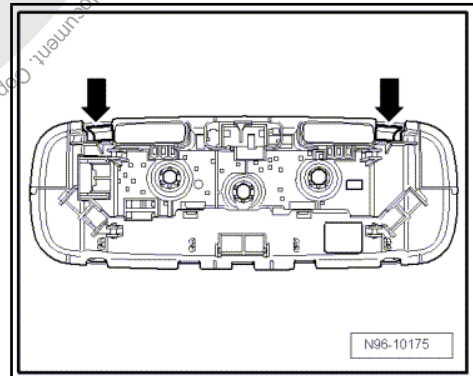

- Disconnect connector -arrow-.

Installing:

Install in reverse order of removal.

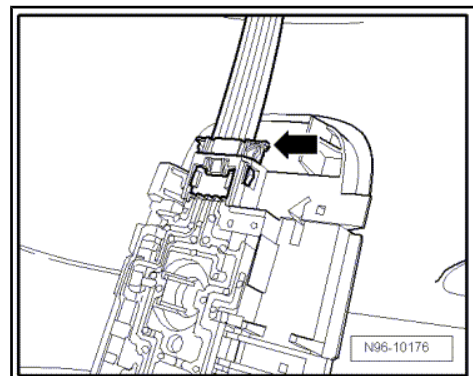



6.3.2 Renewing rear interior and reading light bulbs (vehicles without ATAS)

Removing:

- Release locking lugs -arrows- and take trim with lens off interior light and reading light.

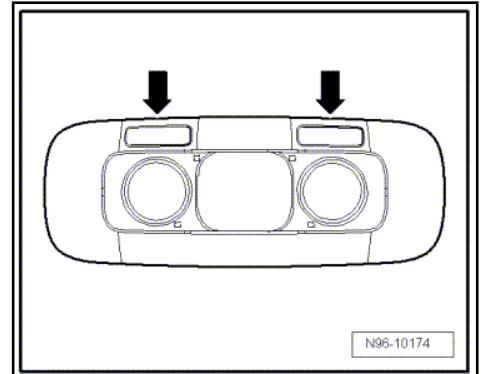

- Pull glass base bulb carefully out of the holder -arrows-.
- Renew defective glass base bulb (12 V, 5 W).

Installing:

Install in reverse order of removal.

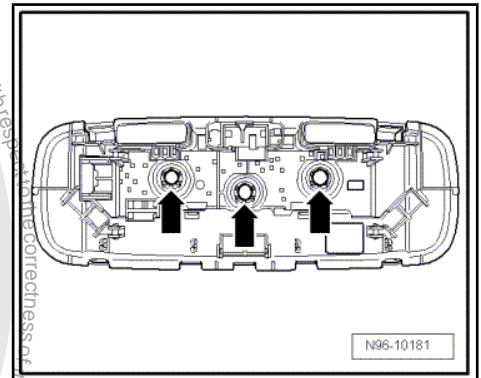

6.4 Rear interior and reading light (vehicles with ATAS)

The following components are integrated in the rear interior light and reading light:

- ◆ Rear left footwell light -W45-
- ◆ Rear left reading light -W11-
- ◆ Rear right reading light -W12-
- ◆ Anti-theft alarm ultrasonic sensor -G209-



Note

- ◆ The switches -1- of the reading lights are integrated in the rear interior and reading light and cannot be renewed separately.
- ◆ The anti-theft alarm ultrasonic sensor -G209- -2- cannot be renewed separately.
- ◆ The anti-theft alarm ultrasonic sensor -G209- , comprising four individual sensors -2-, leads and a control element on the back of the interior and reading light, must not be moved from its predefined position.

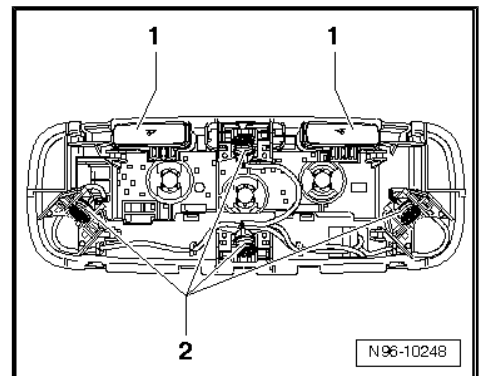



6.4.1 Removing and installing rear interior and reading light (vehicles with ATAS)



Note

- ◆ If a rear interior and reading light is removed, the ATAS must be deactivated ⇒ [page 277](#).
- ◆ The switches -1- of the reading lights are integrated in the rear interior and reading light and cannot be renewed separately.
- ◆ The anti-theft alarm ultrasonic sensor -G209- -2- cannot be renewed separately.
- ◆ The anti-theft alarm ultrasonic sensor -G209- , comprising four individual sensors -2-, leads and a control element on the back of the interior and reading light, must not be moved from its predefined position.

Removing:

- Switch off the ignition and all electrical consumers.
- Pull the entire complete trim -1- (including lens and reflectors) -arrows- vertically downwards and out from the interior and reading light.

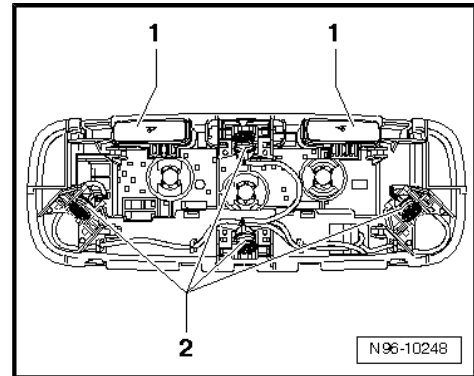

- Press both locking tabs -2- in direction of arrow A- and take the complete interior and reading light -1- in -direction of arrow B- off the headliner.

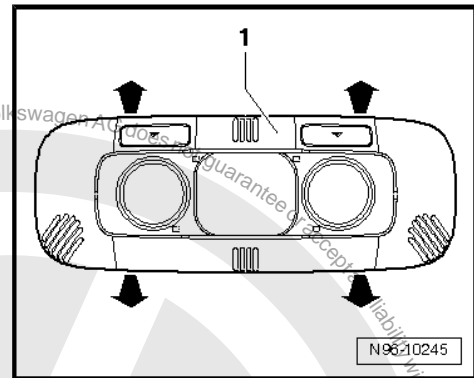

- Unlock connectors -1- and -2- and pull both connectors off.

Installing:

Install in reverse order of removal.

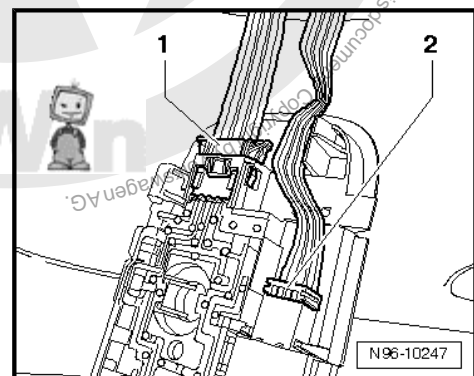
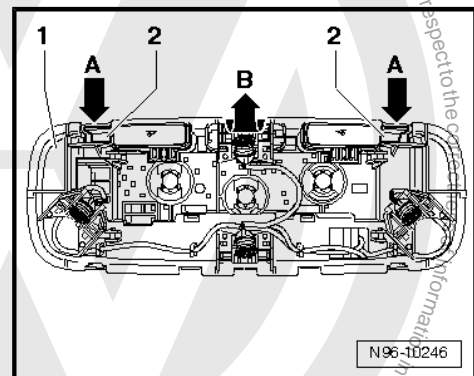



6.4.2 Renewing rear interior and reading light bulbs (vehicles with ATAS)

Note

- ◆ If a rear interior and reading light bulb is renewed, the ATAS must be deactivated => [page 277](#).
- ◆ The anti-theft alarm ultrasonic sensor -G209-, comprising four individual sensors -2-, leads and a control element on the back of the interior and reading light, must not be moved from its predefined position.

Removing:

- Switch off the ignition and all electrical consumers.
- Pull the entire complete trim -1- (including lens and reflectors) vertically downwards and out from the interior and reading light.

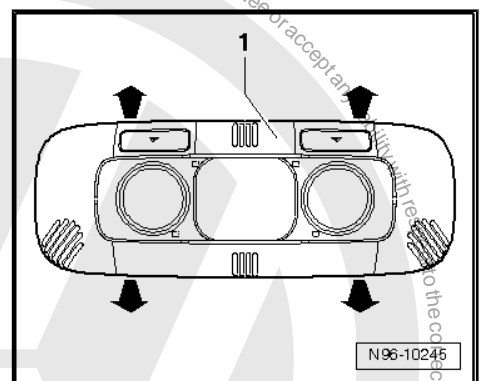
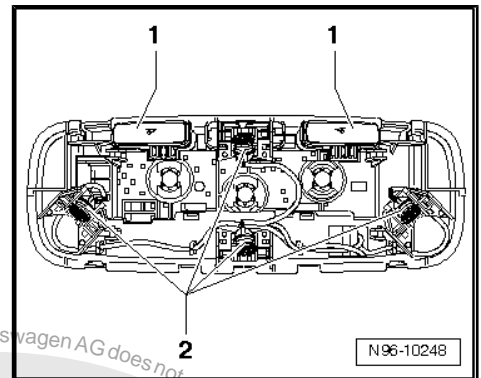

- Pull the glass base bulb to be removed (12 V, 5 W) -1- from the holder.

Installing:

Install in reverse order of removal.

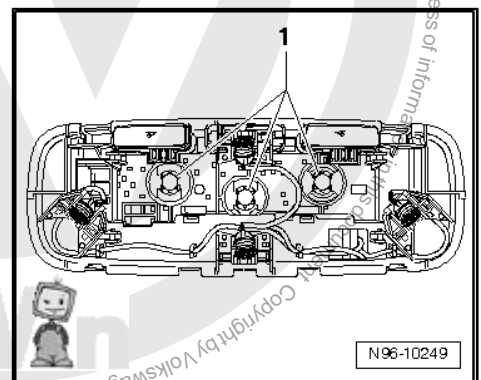

6.5 Removing and installing front passenger side illuminated vanity mirror -W14- and driver side illuminated vanity mirror -W20-

Special tools and workshop equipment required



◆ Removal wedge -VAS 3409-

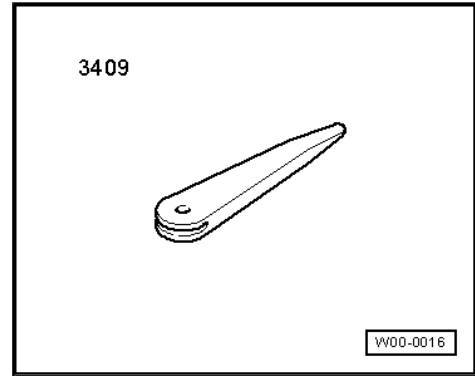

Note

- ◆ When removing and installing components in visual area (connectors, covers, trims etc.) apply a commercial adhesive tape where a lever tool is applied (removal wedge -VAS 3409-, screwdriver).
- ◆ The removal and installation of both lights is the same so that only one light is described.

Removing:

- Switch off the ignition and all electrical consumers.
- Lever light carefully out of the roof trim using removal wedge -VAS 3409- or a screwdriver.

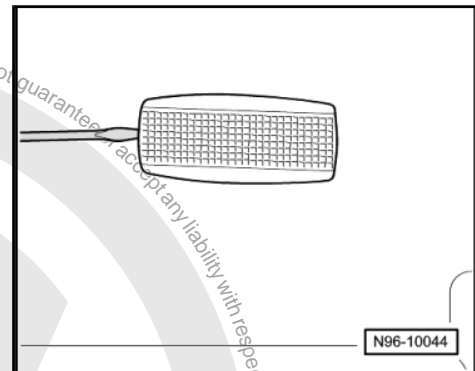

- Disconnect connector -arrow-.

Renew bulb:

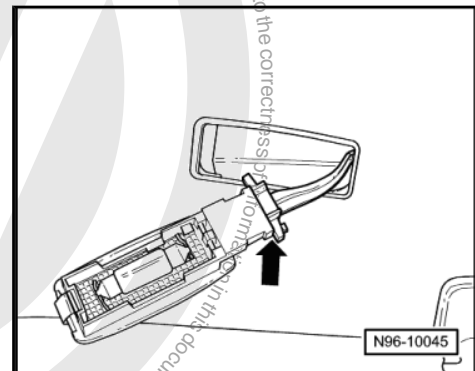



- Press contact -1- of the light in direction of arrow and take festoon bulb -2- out of the socket.
- Renew festoon bulb (12 V, 5 W).

Installing:

Install in reverse order of removal.

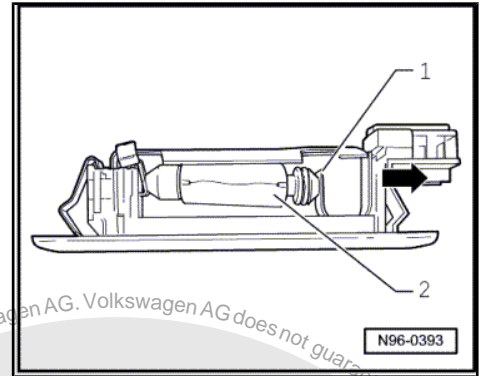

6.6 Removing and installing garage door operating unit -E284-



Note

- ◆ *The garage door operating unit -E284- is located in the sun visor on the driver side.*
- ◆ *The sun visor and the garage door operating unit -E284- may only be replaced together.*
- Remove the sun visor on the driver side with garage door operating unit -E284- -1- ⇒ General body repairs, interior; Rep. Gr. 68 ; Removing and installing sun visor

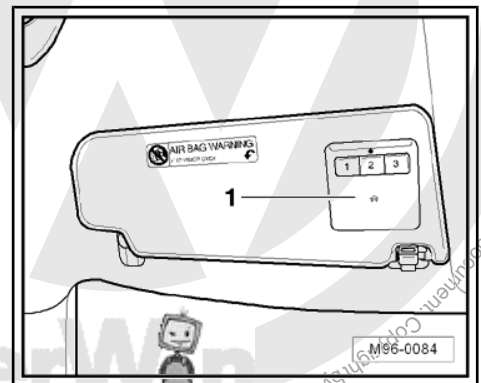



7 Lights and switches in centre console

7.1 Removing and installing TCS and ESP button -E256-

Removing:

- Switch off the ignition and all electrical consumers.
- Take bellow carefully off centre console -arrows-.

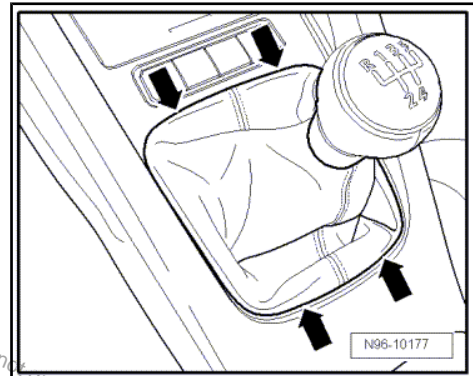

- Unbolt securing bolts -arrows-.
- Take mounting frame with ashtray out of the centre console.

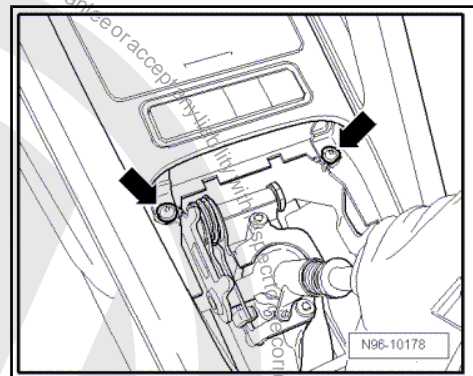

- Remove connectors -arrows-.

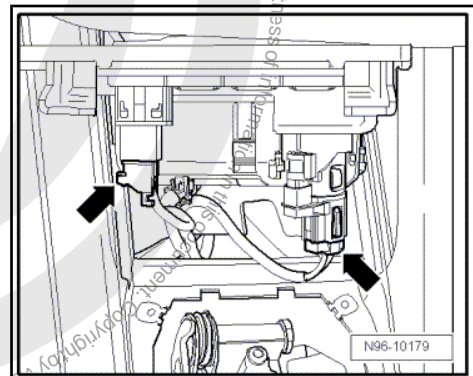



- Release locking lugs -arrows- and remove switch from the installation frame.

Installing:

Install in reverse order of removal.

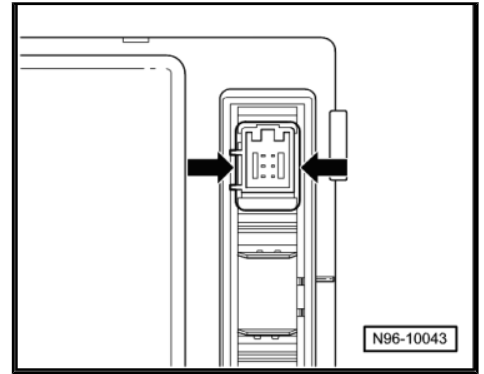



8 Horn

8.1 Removing and installing treble tone horn -H2- and bass tone horn -H7-



Note

- ◆ *The treble tone horn -H2- and the bass tone horn -H7- are controlled in parallel from the onboard supply control unit -J519- .*
- ◆ *The procedure for removal and installation of treble tone horn -H2- and bass tone horn -H7- is the same and is therefore described for just one horn.*
- ◆ *The horns are installed to the left and the right of the longitudinal members.*

Removing:

- Switch off the ignition and all electrical consumers.
- Remove front bumper ⇒ General body repairs; Rep. Gr. 63 ; Front bumper
- Disconnect connector -arrow-.

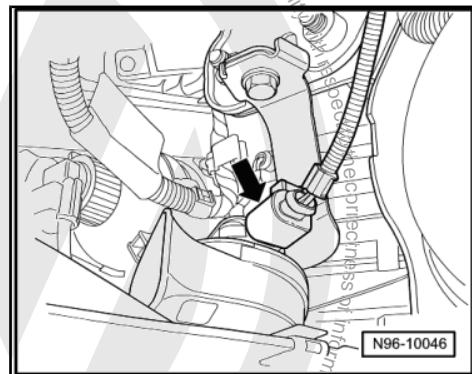

- Unscrew securing bolt -arrow- and remove horn.

Installing:

Install in reverse order of removal.

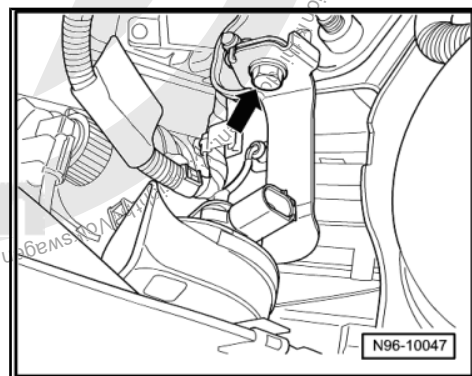

8.2 Checking treble tone horn -H2- and bass tone horn -H7-

The horns (treble tone horn -H2- and bass tone horn -H7-) can be checked using final control diagnosis from the onboard supply control unit -J519- .



9 Immobilizer

General description:

The vehicle is equipped with an immobilizer of the 4th generation.

Modifications by comparison with the immobilizer of the 3rd generation:

- ◆ An adaptation of components of other group marks to Volkswagen vehicles is no longer possible.
- ◆ Vehicle keys are preprogrammed with a base code by the manufacturer. This base code includes a specific manufacturer's code. It is only possible to learn a key of a vehicle if they are programmed with the right manufacturer's code.

Fault detection and fault display:

The immobilizer is equipped with self-diagnosis which makes fault finding easier.

For fault finding, use the vehicle diagnosis, testing and information system -VAS 5051A- in "guided fault finding" mode.

9.1 Immobilizer control unit -J362-

The immobilizer control unit -J362- is integrated in the dash panel insert. If the control unit is defective the complete dash panel insert must be renewed.

- Renewing dash panel insert ⇒ [page 150](#) .

9.2 Immobilizer reader coil -D2-

The immobilizer reader coil -D2- is joined to the ignition switch and cannot be renewed individually.

- Removing and installing ignition switch ⇒ [page 231](#) .

9.3 Ignition key

- Removing and installing the ignition key battery with radio remote control ⇒ General Body Repairs, Exterior; Rep. Gr. 57 ; Central locking; Removing and installing battery for the (folding) main key with radio remote control .
- Removing and installing the radio container (transmission unit for radio-controlled central locking) for the ignition key ⇒ General Body Repairs, Exterior; Rep. Gr. 57 ; Central locking; Removing and installing battery for the (folding) main key with radio remote control .

9.3.1 Ignition key - change code transponder

It is not possible to replace the change code transponder in the ignition key.

The entire key must always be replaced if the change code transponder is found to be defective.



Note

- ◆ *If an ignition key is replaced or an additional ignition key is required, the new ignition key must always be adapted to the immobilizer ⇒ [page 276](#) .*
- ◆ *If the radio container (transmission unit for radio-controlled central locking) of the ignition key is also replaced, it must be adapted to the comfort system ⇒ [page 276](#) .*



9.3.2 Adapting ignition keys to the immobilizer

- Connect Vehicle Diagnosis, Testing and Information System -VAS 5051A- → [page 281](#) .
- Select “guided fault finding” in Vehicle Diagnosis, Testing and Information System -VAS 5051A- .
- Using the “Go to” key, select “Function/component selection” and the following menu items one after the other:
 - ◆ Body
 - ◆ Electrical System
 - ◆ 01 - On Board Diagnostic capable systems
 - ◆ Immobilizer
 - ◆ Immobilizer functions
 - ◆ Adapting ignition keys

9.3.3 Adapting ignition keys to the comfort system

- Connect Vehicle Diagnosis, Testing and Information System -VAS 5051A- → [page 281](#) .
- Select “guided fault finding” in Vehicle Diagnosis, Testing and Information System -VAS 5051A- .
- Using the “Go to” key, select “Function/component selection” and the following menu items one after the other:
 - ◆ Body
 - ◆ General Body Repairs
 - ◆ 01 - On Board Diagnostic capable systems
 - ◆ Comfort system
 - ◆ Comfort system central control unit functions
 - ◆ J393 - Adapting / testing keys with radio remote control



10 Anti-theft alarm system (ATAS)



Note

Additional information:

⇒ Operating instructions

General description:

The functions of the ATAS are integrated into the central control unit for comfort system -J393- .

Fault detection and fault display:

The anti-theft alarm system is equipped with self-diagnosis which makes fault finding easier.

For fault finding, use the vehicle diagnosis, testing and information system -VAS 5051A- in "guided fault finding" mode.



Note

Once the anti-theft alarm system has been triggered, the alarm source that has been stored in the convenience system central control unit -J393- can be interrogated ⇒ [page 298](#) .

10.1 Activating and deactivating anti-theft alarm system

Activating anti-theft alarm system:

The anti-theft alarm system is switched on automatically when the vehicle is locked. The system is then immediately armed.



Note

Completely close all windows and doors before locking the vehicle to prevent the anti-theft alarm system triggering an unnecessary alarm.

Deactivating anti-theft alarm system:

- ◆ The system is deactivated when the vehicle is unlocked using the radio remote control key or
- ◆ when the ignition is switched on.

Unlock the car mechanically (emergency open)

- Unlock the driver door.

The anti-theft alarm system remains active, although no alarm is triggered.

- Switch ignition on within 15 seconds.



Note

If you do not switch on the ignition, the alarm will trigger after 15 seconds.



When the ignition is switched on, the electronic immobilizer detects a valid vehicle key and deactivates the anti-theft alarm system.

10.2 Removing and installing anti-theft alarm ultrasonic sensor -G209-

The anti-theft alarm ultrasonic sensor -G209- , comprising 4 individual sensors -2-, leads and a control element on the back of the interior and reading light, cannot be replaced individually, the entire rear interior and reading light must be replaced.

- Removing and installing rear interior and reading light (vehicles with ATAS) ⇒ [page 268](#) .

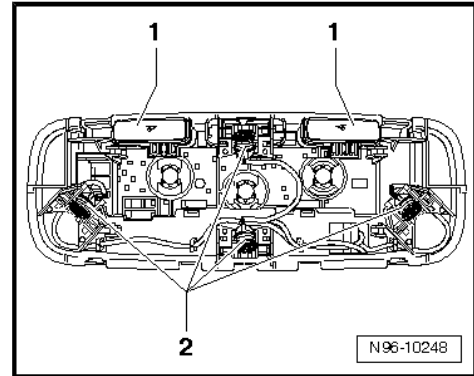

10.3 Removing and installing vehicle inclination sender -G384-

The vehicle inclination sender -G384- -arrow- is located under the dash panel right behind the front passenger airbag.



Note

The anti-theft alarm system must be deactivated before the sender is removed ⇒ [page 277](#) .

Removing:

- Switch off ignition and all electrical consumers and pull out ignition key.
- Remove glove compartment ⇒ General body repairs, interior; Rep. Gr. 68 ; Compartments, covers and trim; Removing and installing glove compartment; Removing .
- Unscrew the securing bolts -1- and remove vehicle inclination sender -G384- from the bracket.
- Release the connector -2- and pull it away from the vehicle inclination sender -G384- .

Installing:

Install in reverse order of removal.

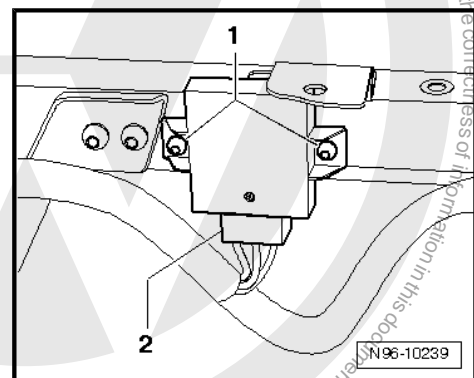
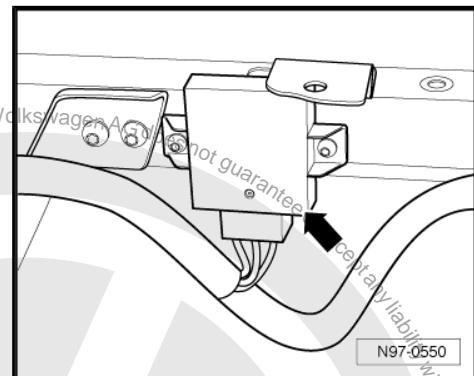

10.4 Central locking and anti-theft alarm system aerial -R47-



Note

Additional information:



⇒ Current flow diagrams, Electrical fault finding and Fitting locations

The central locking and anti-theft alarm system aerial -R47- is laid from the central locking and anti-theft alarm system aerial -J393- to the A-pillar (driver side) in the main wiring loom.



Note

- ◆ *The antenna cannot be repaired as this would adversely affect the reception quality.*
- ◆ *In the event of damage, it is necessary to replace the central locking and anti-theft alarm system aerial -R47- .*

10.5 Alarm horn -H12-

The alarm horn -H12- is located on the right of the A-pillar in the wing.

10.5.1 Removing and installing the alarm horn -H12-

Special tools and workshop equipment required

- ◆ Drill -VAS 5134-

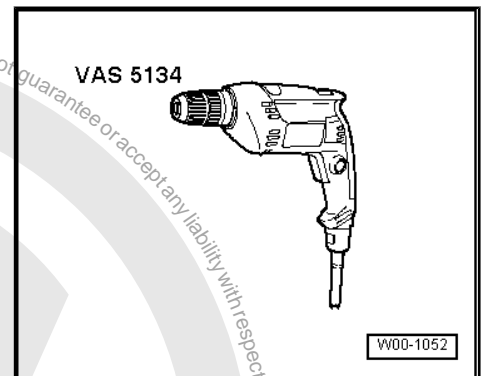

- ◆ Twist drill \varnothing 6 mm
- ◆ Pop rivet pliers -VAS 5072-

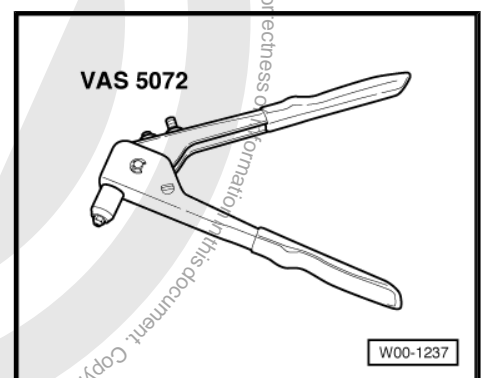

Note

The anti-theft alarm system must be deactivated before the alarm horn is removed ⇒ [page 277](#) .

Removing:

- Switch off ignition and all electrical consumers and pull out ignition key.



- Remove front right wheel housing liner ⇒ General body repairs, interior; Rep. Gr. 66 ; Wheel housing liner; Removing and installing front wheel housing liner; Removing
- Drill out both pop rivets -arrows- using drill -VAS 5134- and Ø 6 mm twist drill.

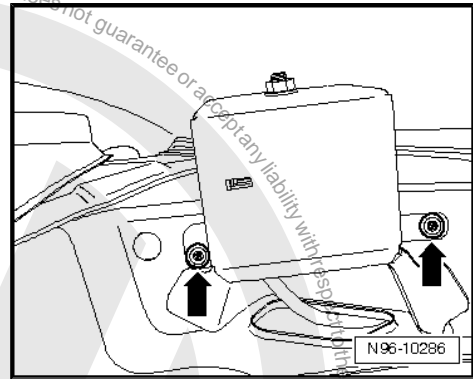

- Pull alarm horn -H12- -1- in -direction of arrow- out of the aperture in the bodywork.
- Pull connector off -2-.

Installing:



Note

Remove all metal particles caused during the drilling.

- Perform measures for corrosion protection ⇒ General Information; Body Repairs, General Body Repairs .
- Fit connector to the alarm horn -H12- .
- Insert clip -2- of alarm horn -H12- -3- into the aperture in the bodywork -1-.
- Secure alarm horn -H12- with pop rivet pliers -VAS 5072- .

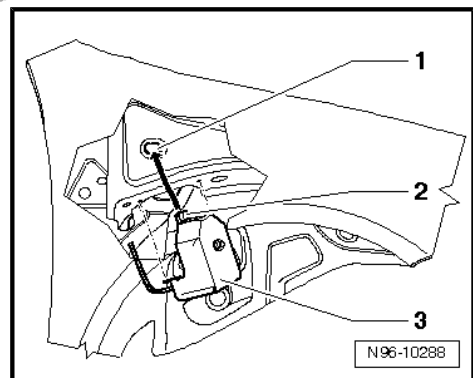
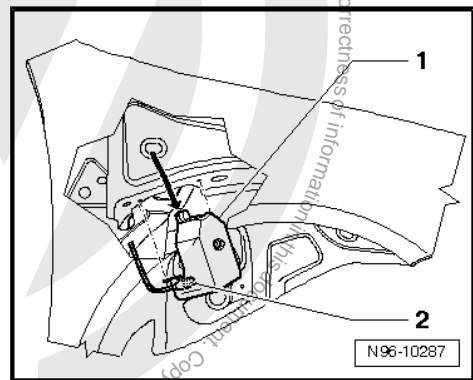

10.5.2 Checking alarm horn -H12-

The alarm horn -H12- can be tested using final control diagnosis from convenience system central control unit -J393- .



97 – Wiring

1 Vehicle Diagnosis, Testing and Information Systems



WARNING

- ◆ *During testing or measuring operations using a vehicle diagnosis information system, there is a risk of serious or even fatal injury!*
- ◆ *If the vehicle diagnosis information system is lodged in the activity area of an airbag during a testing or measuring operation, a triggered airbag can result in serious or even fatal injury!*
- ◆ *During testing and measuring operations, work with a second person who can operate the vehicle diagnosis information system from one of the rear seats!*



Note

- ◆ *All working instructions described, such as modifications, coding etc. can be carried out using the vehicle diagnosis, testing and information system -VAS 5051A- and the vehicle diagnosis and service information system -VAS 5052- .*
- ◆ *All working instructions can be found in "guided fault finding" and "guided functions".*
- ◆ *Additional information:*
 - ⇒ Self-study programme No. 202 ; Vehicle Diagnosis, Testing and Information System VAS 5051
 - ⇒ Self-study programme No. 256 ; VAS 5052
 - ⇒ Self-study programme No. 294 ; Online connection of the VAS 5051
 - Connecting Vehicle Diagnosis, Testing and Information System -VAS 5051A- → [page 281](#) .
 - Connecting vehicle Diagnosis, Testing and Information System -VAS 5052- → [page 282](#) .

1.1 Connecting vehicle Diagnosis, Testing and Information System -VAS 5051A-



Note

Observe the latest operating instructions for vehicle diagnosis, testing and information system -VAS 5051A- , which are displayed after selecting the "Administration" and "Operating Manual" buttons.

Special tools and workshop equipment required



◆ Vehicle Diagnosis, Testing and Information System -VAS 5051A-

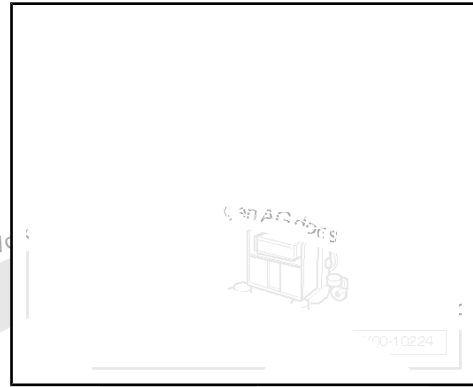

◆ Diagnosis lead -VAS 5051/6A- (5 m)

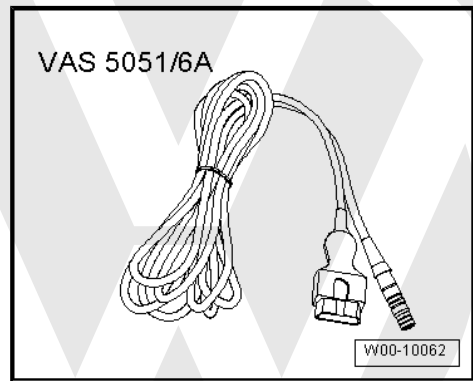

◆ Diagnosis lead -VAS 5051/5A- (3 m)



Note

Only these leads are to be used for diagnosis, as they are the only ones fitted with CAN lines and therefore allowing CAN diagnosis and/or CAN communication.

Connecting Vehicle Diagnosis, Testing and Information System -VAS 5051A- :

- Apply handbrake.
- On vehicles with automatic gearbox, move selector lever to position "P" or "N".
- On vehicles with manual gearbox, move gear stick to neutral position.
- With the ignition switched off, connect vehicle diagnosis, testing and information system -VAS 5051A- using diagnostic lead -VAS 5051/6A- to diagnostic interface -arrow- in vehicle.
- Switch ignition on.
- Switch off all electrical consumers.



Note

Any additional vehicle diagnosis, measuring and information systems and/or vehicle diagnosis and service information systems are connected in the sequence described above.

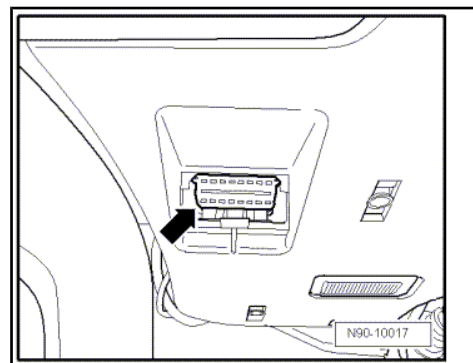



2 Removing and installing fuse holder

2.1 Removing and installing fuse holder on left of dash panel

Special tools and workshop equipment required

- ◆ Removal wedge -VAS 3409-

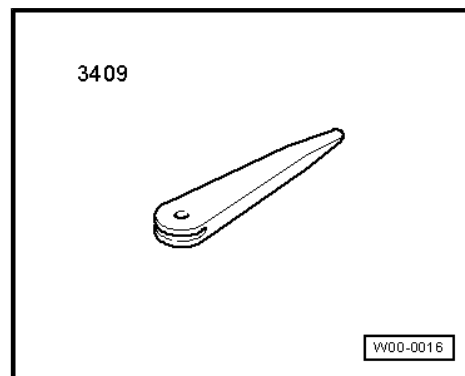

Note

When removing and installing components in visual area (connectors, covers, trims etc.) apply a commercial adhesive tape where a lever tool is applied (removal wedge -VAS 3409-, screwdriver).



Caution

Disconnecting and connecting the battery as described in the Workshop Manual ⇒ [page 29](#) .

Removing:

- Disconnect the battery ⇒ [page 29](#) .
- Remove storage compartment on driver side ⇒ General body repairs, interior; Rep. Gr. 68 ; Compartments, covers and trim .



- Remove lateral cover -1- out of the dash panel, by inserting the removal wedge -VAS 3409- or a screwdriver in the recess -2- and lever off cover -1- in -direction of arrow-.

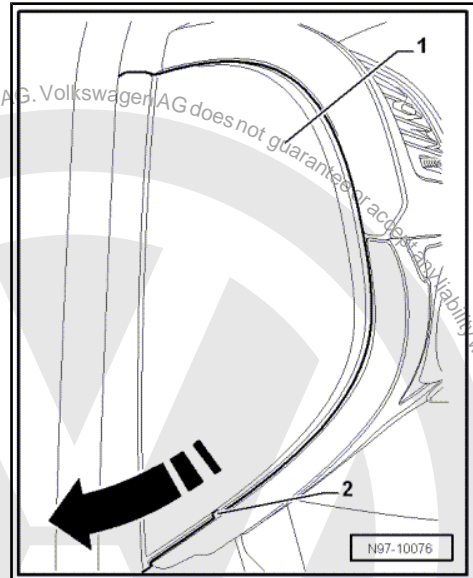

- Take fuse assignment card -1- out of fuse holder -2-.
- Remove securing bolts -arrows- and take fuse holder -1- out as far it is possible (depending on cable length).

Installing:

Install in reverse order of removal.

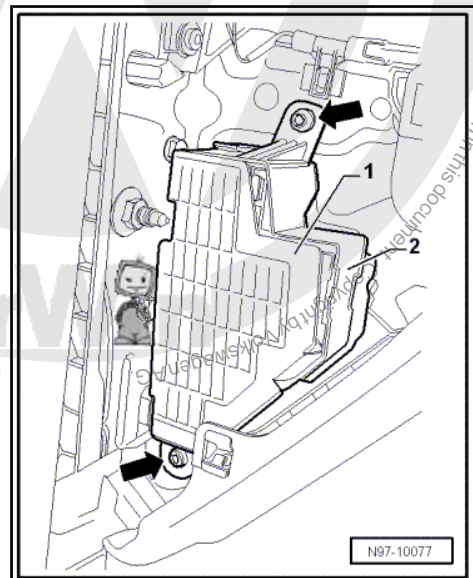



3 Removing and installing relay carrier

3.1 Removing and installing relay carrier with safety cut-out on left of dash panel



Caution

Disconnecting and connecting the battery as described in the Workshop Manual ⇒ page 29 .

Removing:

- Disconnect the battery ⇒ page 29 .
- Remove storage compartment on driver side ⇒ General body repairs, interior; Rep. Gr. 68 ; Compartments, covers and trim .
- Unscrew bolts -arrows- of the bracket.

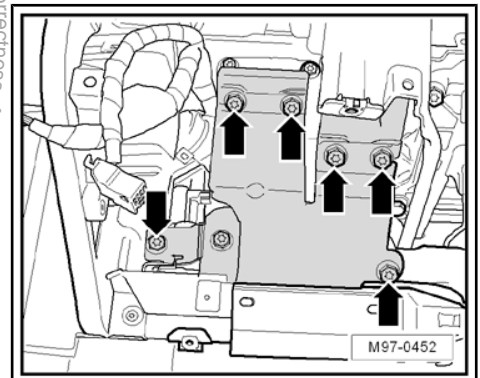

- Pull relays -arrows- out of the relay carrier.



Note

The relay number depends on vehicle equipment.

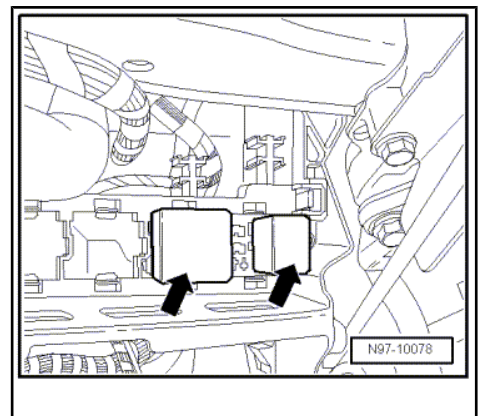

- Clip locking lugs in -direction of arrow- outwards and then press the connector -1- through the relay carrier.

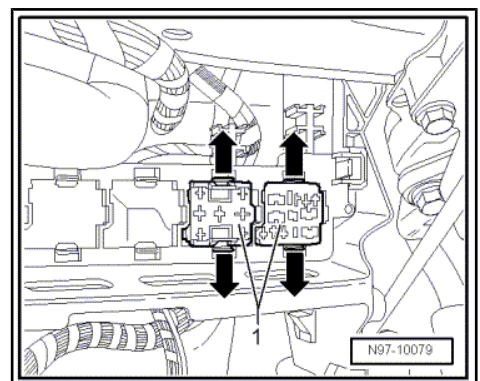



- Unlock locking lug -1- of relay carrier in -direction of arrow- and take relay carrier off.

Installing:

Installation is performed in the reverse order of installation; when doing this, note the following:

- Clip connectors into the relay carrier first.
- Fit relay carrier -2- into guide -1- and engage relay carrier.

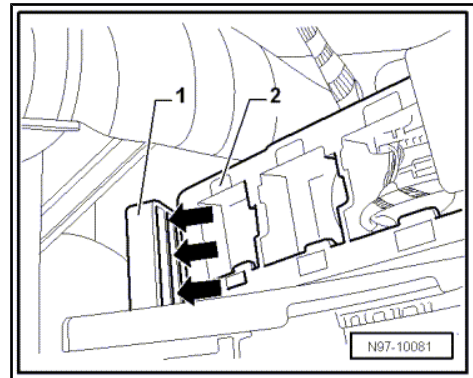
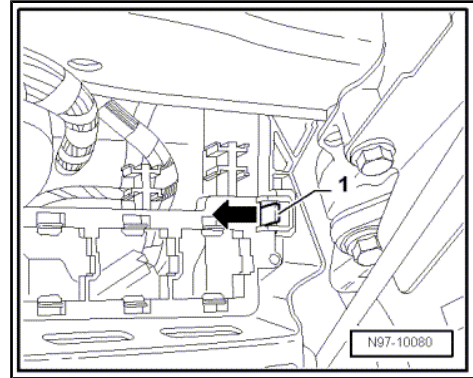

3.2 Removing and installing relay carrier on onboard supply control unit, on left of dash panel



Note

- ◆ *The onboard supply control unit -J519- and the relay carrier attached to the onboard supply control unit, on left of dash panel form one unit and cannot be separated.*
- ◆ *If the onboard supply control unit -J519- is to be replaced, first carry out the procedure ⇒ ["5.1.2 Coding onboard supply control unit J519"](#), page 293 to read out the stored codes.*

Removing:

- Switch off ignition and all electrical consumers and pull out ignition key.
- Remove cover, footwell, on driver side ⇒ General body repairs, interior; Rep. Gr. 68 ; Compartments, covers and trim .
- Remove storage compartment on driver side ⇒ General body repairs, interior; Rep. Gr. 68 ; Compartments, covers and trim .



- Move locking bar -1- of the relay carrier connectors on onboard supply control unit, on left of dash panel in -direction of arrow A-.
- Move locking bar -2- of the connectors of the on onboard supply control unit -J519- in -direction of arrow B-.

i Note

The connectors of the onboard supply control unit -J519- and the relay carrier on onboard supply control unit, on left of dash panel may only be pulled off if the locking bar is set to position "OPEN".

- Remove all connectors of the onboard supply control unit -J519- and the relay carrier on onboard supply control unit, on left of dash panel.

i Note

The connector number depends on vehicle equipment.

- Unclip onboard supply control unit -J519- and relay carrier on onboard supply control unit, on left of dash panel out of the locking device -arrows C-.
- Pull onboard supply control unit -J519- and relay carrier on onboard supply control unit, on left of dash panel downwards and in opposite direction of travel out of the bracket.

Installing:

Installation is performed in the reverse order of installation; when doing this, note the following:

i Note

The locking bars may only be set to "CLOSE" when all connectors are fitted "correctly".

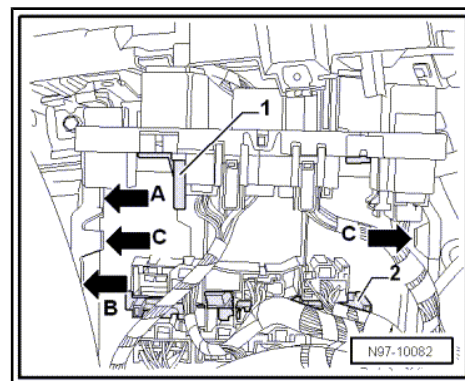



4 Electronics boxes

4.1 Removing and installing electronics box on left in engine compartment



Caution

Disconnecting and connecting the battery as described in the Workshop Manual ⇒ [page 29](#).

Removing:

- Disconnect the battery ⇒ [page 29](#).
- Release clips -1- in -direction of arrow- and take cover of electronics box -2- off upwards.

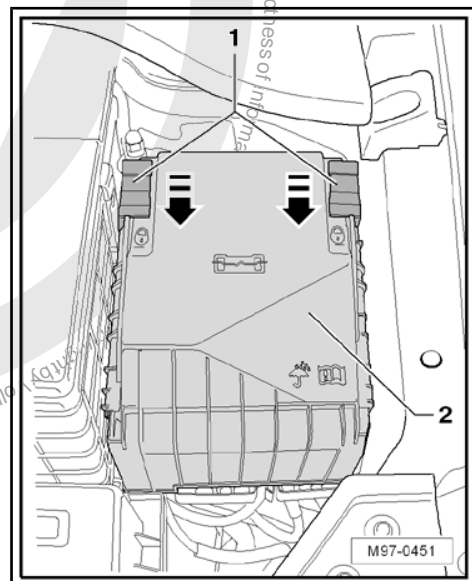

- Remove hexagon nuts -1-.
- Open -arrows- covers -2- of cable guides on electronics box.
- Remove wiring from stud connections.
- Unclip wiring from cable guides.

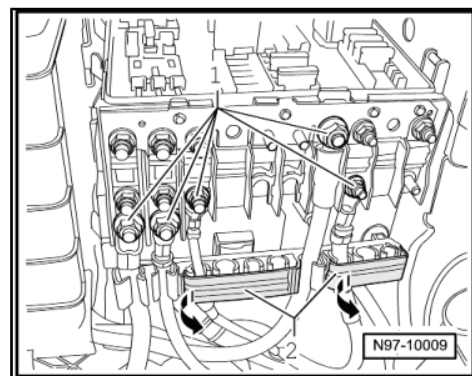



- Remove central securing screw -arrow- from electronics box -1-.



Note

When the central securing screw -arrow-, the electronics box -1- is pushed upwards off the electronics box mounting.

- Pull electronics box -1- upwards off electronics box mounting.

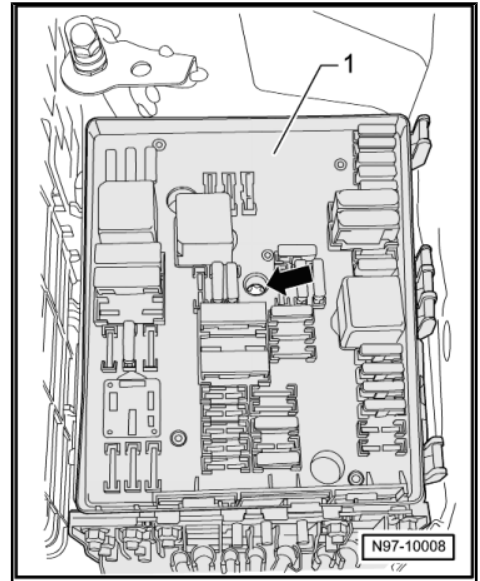

Note

For removal of the flat contact housing -1-, the air filter (on vehicles with diesel engine only), the battery and the battery console must be removed.

- Remove air filter housing, if necessary.
- Remove battery => [page 29](#) .

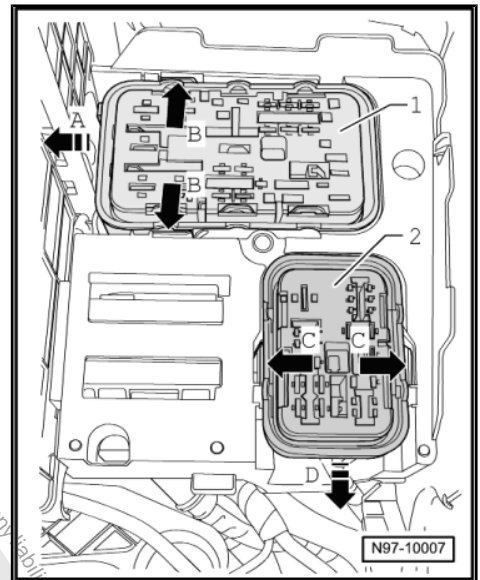

- Remove securing bolts -arrows- of battery console -1-.
- Take battery console -1- out of vehicle.

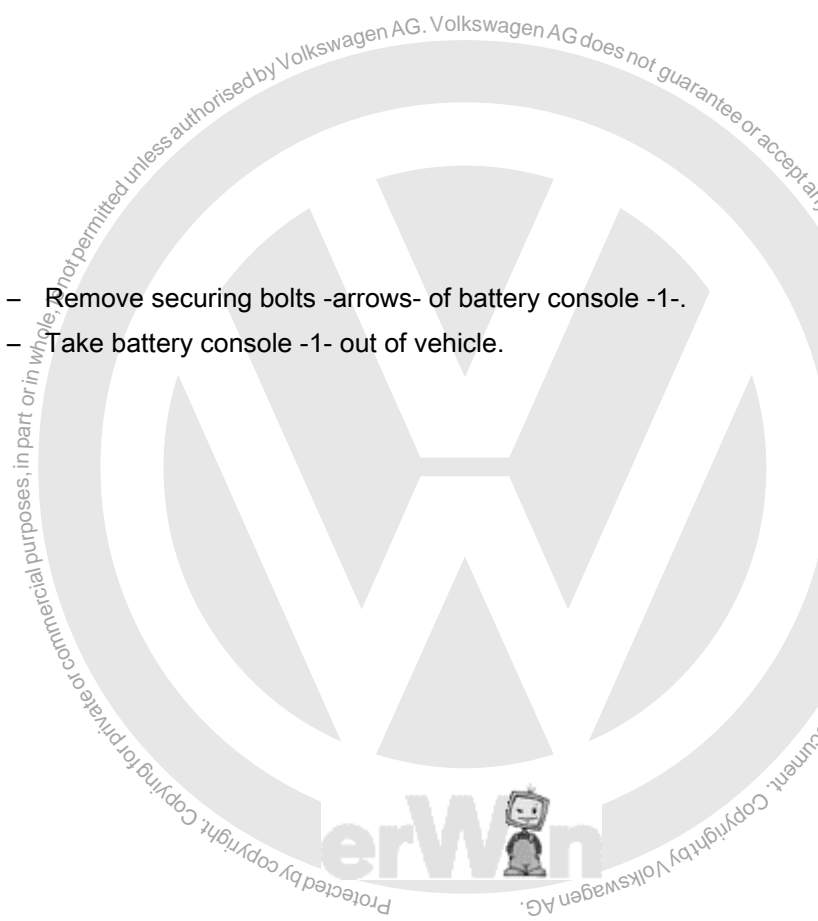
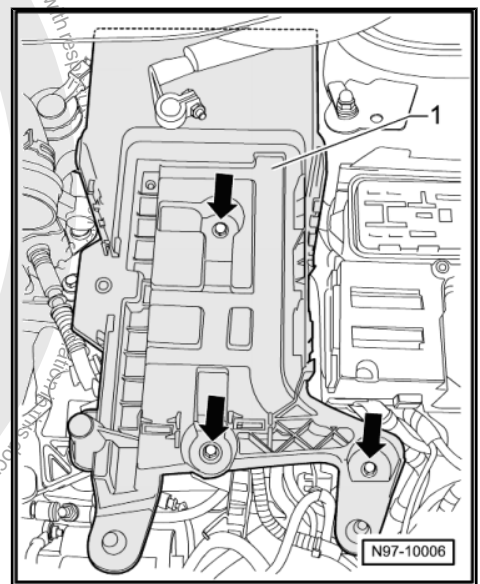



- Press tabs apart on bracket of electronics box -arrows B- and slide flat contact housing -1- sideways -arrow A- out of bracket of electronics box.
- Press tabs apart on bracket of electronics box -arrows C- and slide flat contact housing -2- forwards -arrow D- out of bracket of electronics box.

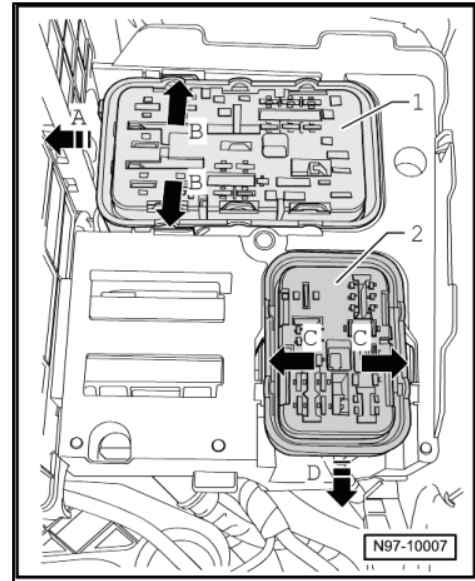

- Unscrew securing nuts -arrows- of bracket from electronics box -1-.



Note

Whether the additional relay carrier is installed depends on the vehicle equipment.

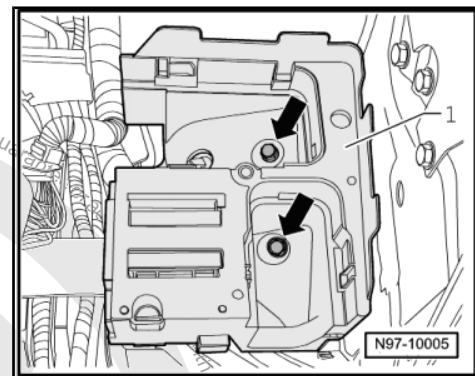

- Pull bracket of electronics box -1-, upwards off studs as far as relay carrier cables allow.
- Unclip relay carrier -1- sideways out of bracket of electronics box -2-.
- Take bracket of electronics box -2- out of vehicle.

Installing:

Installation is performed in the reverse order of installation; when doing this, note the following:

- Tighten threaded connections to specified torque settings
⇒ [page 307](#) .

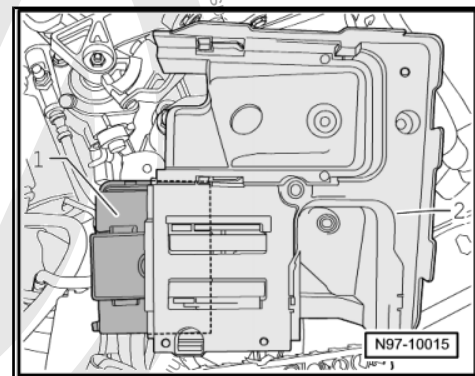



- Mount the cover -2- on the electronics box and push the safety clip -1- in -direction of arrow- until cover -2- engages.



Note

Then check whether the cover -2- of the electronics box is engaged correctly.

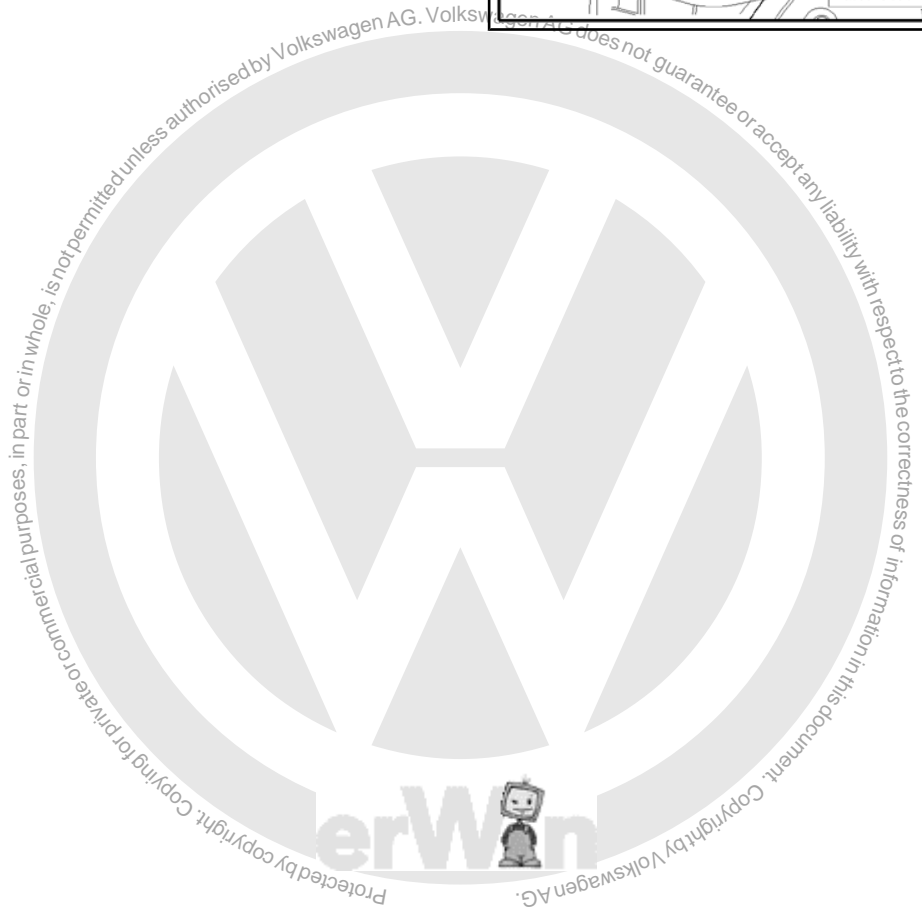
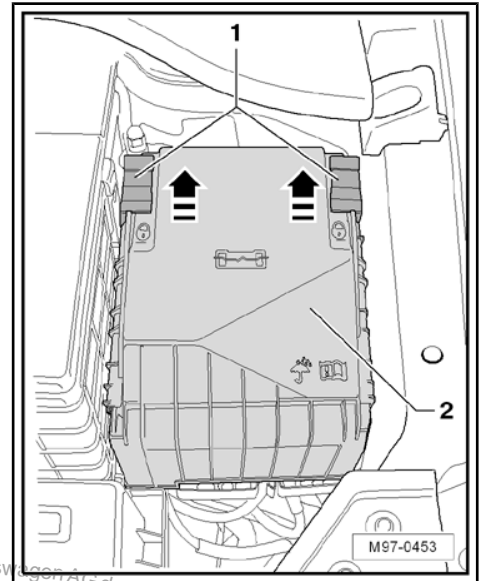



5 Control units

5.1 Onboard supply control unit -J519-



Note

- ◆ *The onboard supply control unit -J519- and the relay carrier attached to the onboard supply control unit, on left of dash panel form one unit and cannot be separated.*
- ◆ *Additional information:*

⇒ Current flow diagrams, Electrical fault finding and Fitting locations

⇒ Operating instructions

General description:

The onboard supply control unit -J519- is responsible for the following in the vehicle:

- ◆ Electrical load management
- ◆ Exterior light control
- ◆ Turn signal control
- ◆ Rear window wiper
- ◆ Heated rear window
- ◆ Terminal control
- ◆ Surround lighting
- ◆ Terminal control
- ◆ Dimmers, instrument lighting
- ◆ Fuel pump presupply
- ◆ Alternator stand-by
- ◆ Horn

The following functions can be adapted:

- ◆ Deleting learning values and setting standard adaptation values
- ◆ Adjusting period for coming home function (depending on equipment)
- ◆ Adjusting period for leaving home function (depending on equipment)
- ◆ Adjusting rear window heating "On time"
- ◆ Switching on and off footwell lighting
- ◆ Switching on and off motorway signaling
- ◆ Adjusting load management
- ◆ Adjusting "activation time" for headlight cleaning system
⇒ [page 294](#)



Note

- ◆ *The above adaptations can only be carried out in conjunction with certain equipment configurations.*
- ◆ *The "Motorway signaling", "comfort signaling", or "tap signaling" means that one touch of the turn signal lever will activate the turn signals (1-5 times) (turn signal cycles).*
- ◆ *If the onboard supply control unit -J519- is to be replaced, first carry out the procedure ⇒ ["5.1.2 Coding onboard supply control unit J519"](#), [page 293](#) , so that access can be gained to the codes stored within.*

Fault detection and fault display:

The onboard supply control unit -J519- is equipped with self-diagnosis, which is designed to ease fault finding.

For fault finding, use the vehicle diagnosis, testing and information system -VAS 5051A- in "guided fault finding" mode.

5.1.1 Removing and installing onboard supply control unit -J519-



Note

If the onboard supply control unit -J519- is to be replaced, first carry out the procedure ⇒ ["5.1.2 Coding onboard supply control unit J519"](#) , [page 293](#) , so that access can be gained to the codes stored within.

Removing:

The removal of the onboard supply control unit -J519- corresponds to the removal of the relay carrier on onboard supply control unit, on left of dash panel ⇒ [page 286](#) .

Installing:

The installation of the onboard supply control unit -J519- corresponds to the installation of the relay carrier on onboard supply control unit, on left of dash panel ⇒ [page 286](#) .

5.1.2 Coding onboard supply control unit - J519-

- Connect Vehicle Diagnosis, Testing and Information System -VAS 5051A- ⇒ [page 281](#) .
- Select "guided fault finding" in Vehicle Diagnosis, Testing and Information System -VAS 5051A- .
- Using the "Go to" key, select "Function/component selection" and the following menu items one after the other:
 - ◆ Body
 - ◆ Electrical System
 - ◆ 01 - On Board Diagnostic capable systems
 - ◆ Onboard supply control unit
 - ◆ Onboard supply control unit functions
 - ◆ Code control unit



5.1.3 Modifying headlight cleaning system

The “active time” of the headlight cleaning system can be variably adjusted to between 0 and 12.75 seconds.

- Connect the vehicle diagnosis, testing and information system -VAS 5051A- to [⇒ page 281](#)
- Select “guided fault finding” in Vehicle Diagnosis, Testing and Information System -VAS 5051A- .
- Using the “Go to” key, select “Function/component selection” and the following menu items one after the other:
 - ◆ Body
 - ◆ Electrical System
 - ◆ 01 - On Board Diagnostic capable systems
 - ◆ Onboard supply control unit
 - ◆ Onboard supply control unit functions
 - ◆ Modifying headlight cleaning system

5.2 Data bus diagnostic interface -J533-



Note

Additional information:

- ⇒ Current flow diagrams, Electrical fault finding and Fitting locations
- ⇒ Operating instructions

General description:

The diagnosis interface for data bus -J533- (gateway) is a separate control unit. It has the following functions in the vehicle:

- ◆ Responsible for exchange of data between CAN data bus systems “drive train CAN data bus”, “convenience CAN data bus” and “Infotainment CAN data bus”
- ◆ Converts diagnostic data from CAN data bus systems to COM wire and vice versa. In this way, data can also be used by the the vehicle diagnosis, testing and information system -VAS 5051A-



Note

If the data bus diagnostic interface -J533- is to be removed, first carry out the procedure

⇒ [“5.2.1 Renewing data bus diagnostic interface J533”](#), [page 295](#) , so that access can be gained to the codes stored within.

Fault detection and fault display:

The data bus diagnostic interface -J533- is equipped with self-diagnosis, which is designed to ease fault finding.

For fault finding, use the vehicle diagnosis, testing and information system -VAS 5051A- in “guided fault finding” mode.



5.2.1 Renewing data bus diagnostic interface -J533-

- Connect Vehicle Diagnosis, Testing and Information System -VAS 5051A- => [page 281](#) .
- Select "guided fault finding" in Vehicle Diagnosis, Testing and Information System -VAS 5051A- .
- Using the "Go to" key, select "Function/component selection" and the following menu items one after the other:
 - ◆ Body
 - ◆ Electrical System
 - ◆ 01 - On Board Diagnostic capable systems
 - ◆ Data bus diagnostic interface
 - ◆ Data bus diagnostic interface functions
 - ◆ Renewing data bus diagnostic interface

5.2.2 Removing and installing data bus diagnostic interface -J533-

Removing:



Note

Before removing data bus diagnostic interface -J533- , it is essential that the following work procedure => ["1 Renewing dash panel insert", page 150](#) is carried out, so that access can be gained to the codes stored within.

- Switch off ignition and all electrical consumers and pull out ignition key.
- Remove cover, footwell, on driver side => General body repairs, interior; Rep. Gr. 68 ; Compartments, covers and trim .
- Release connector -1- and pull connector off data bus diagnostic interface -J533- -2-.
- Push securing pins -3- together -arrows- and pull out of holes.

Installing:

Install in reverse order of removal.

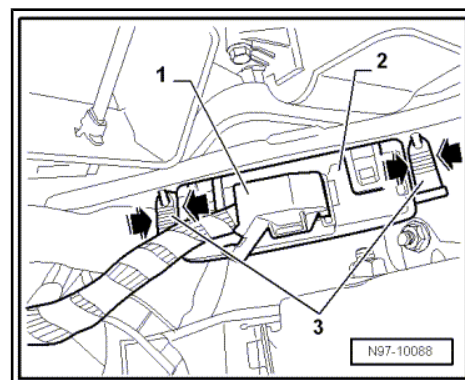

5.3 Central control unit for convenience system -J393-



Note

Additional information:

=> Current flow diagrams, Electrical fault finding and Fitting locations



⇒ Operating instructions

General description:

The convenience system central control unit -J393- is responsible for the following in the vehicle:

- ◆ Sliding/tilting sunroof control (release instruction)
- ◆ Power window control (release instruction)
- ◆ Central locking control
- ◆ Anti-theft alarm system control
- ◆ Radio-wave receiver
- ◆ Rear lid lock
- ◆ Comfort operation

Some of the above functions can be adapted ⇒ [page 298](#) .

Fault detection and fault display:

The convenience system central control unit -J393- is equipped with self-diagnosis, which is designed to ease fault finding.

For fault finding, use the vehicle diagnosis, testing and information system -VAS 5051A- in "guided fault finding" mode.

5.3.1 Removing and installing convenience system central control unit -J393-

Removing:

- Switch off ignition and all electrical consumers and pull out ignition key.
- Remove glove compartment ⇒ General body repairs, interior; Rep. Gr. 68 ; Compartments, covers and trim; Removing and installing glove compartment .
- Pull locking lug -1- off convenience system central control unit -J393- bracket in -direction of arrow- and move the convenience system central control unit -J393- until the recesses -2- align with the recesses -3-.

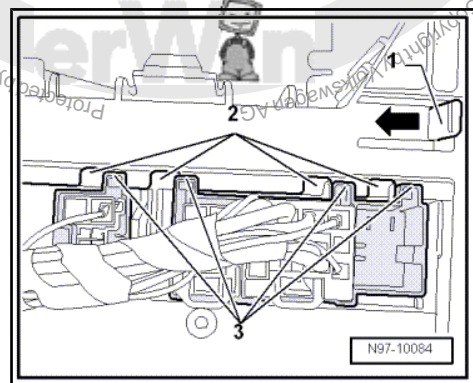

Note

The connectors may only be unlocked and pulled off if the recesses -arrows- of the connectors and the bracket align exactly.

- Unlock connectors and pull them off convenience system central control unit -J393- .

Note

The connector number depends on vehicle equipment.

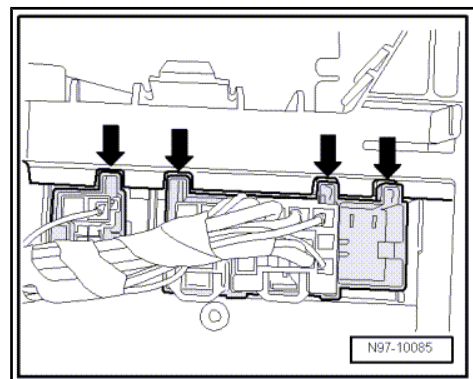



- Unscrew securing nuts -arrows-.
- Take bracket off with convenience system central control unit -J393- .

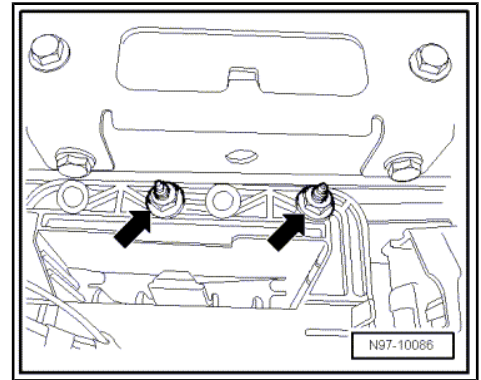

- Pull locking lug -1- in -direction of arrow B- and push convenience system central control unit -J393- -2- out of the bracket in -direction of arrow A-.

Installing:

Installation is performed in the reverse order of installation; when doing this, note the following:

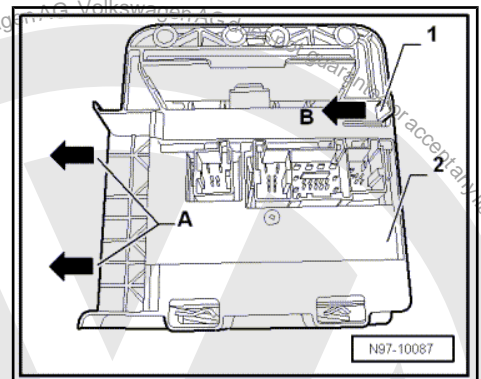

Note

- ◆ After installing a new convenience system central control unit it must be coded => [page 297](#) .
- ◆ The connectors may only be placed and locked if the recesses -arrows- of the connectors and the bracket align exactly.

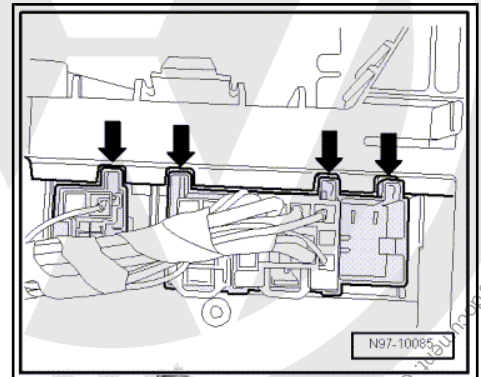

5.3.2 Coding convenience system central control unit -J393-

- Connect Vehicle Diagnosis, Testing and Information System -VAS 5051A- => [page 281](#) .
- Select "guided fault finding" in Vehicle Diagnosis, Testing and Information System -VAS 5051A- .
- Using the "Go to" key, select "Function/component selection" and the following menu items one after the other:
 - ◆ Body
 - ◆ General Body Repairs
 - ◆ 01 - On Board Diagnostic capable systems
 - ◆ Comfort system
 - ◆ Comfort system central control unit functions
 - ◆ J393 - Coding convenience system central control unit



5.3.3 Adapting convenience system central control unit -J393-

The following functions can be adapted:

- ◆ Activating and deactivating “single door opening”
- ◆ Activating and deactivating “automatic locking above >15 Km/h”
- ◆ Activating and deactivating “automatic unlocking when ignition key is removed”
- ◆ Activating and deactivating “country settings for intelligent alarm horn”
- ◆ Activating and deactivating “battery monitoring system (sounder)”
- ◆ Activating and deactivating “comfort operation via radio remote control unit”
- ◆ Activating and deactivating “anti-theft alarm system - alarm delay when driver's door is opened”
- ◆ “Sensitivity of tilt angle sensor”
- ◆ “Sensitivity of interior monitoring system”
- Connect Vehicle Diagnosis, Testing and Information System -VAS 5051A- ⇒ [page 281](#) .
- Select “guided fault finding” in Vehicle Diagnosis, Testing and Information System -VAS 5051A- .
- Using the “Go to” key, select “Function/component selection” and the following menu items one after the other:
 - ◆ Body
 - ◆ General Body Repairs
 - ◆ 01 - On Board Diagnostic capable systems
 - ◆ Comfort system
 - ◆ Comfort system central control unit functions
 - ◆ J393 - Adapting convenience system central control unit

5.3.4 Convenience system central control unit -J393- - Read alarm sources of anti-theft alarm system

- Connect Vehicle Diagnosis, Testing and Information System -VAS 5051A- ⇒ [page 281](#) .
- Select “guided fault finding” in Vehicle Diagnosis, Testing and Information System -VAS 5051A- .
- Using the “Go to” key, select “Function/component selection” and the following menu items one after the other:
 - ◆ Body
 - ◆ General Body Repairs
 - ◆ 01 - On Board Diagnostic capable systems
 - ◆ Comfort system
 - ◆ Comfort system central control unit functions
 - ◆ J393 - Read alarm sources of anti-theft alarm system



5.4 Trailer detector control unit -J345-

The trailer detector control unit -J345- -arrow- is located behind the left side trim in the luggage compartment.



Note

Additional information:

⇒ Current flow diagrams, Electrical fault finding and Fitting locations

⇒ Operating instructions

General description:

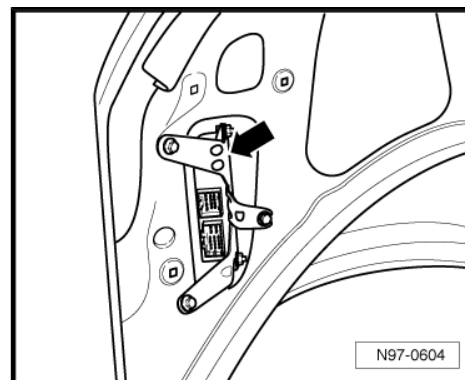

Note

- ◆ *The Golf currently features only control units manufactured by Westfalia.*
- ◆ *To check the control unit use plug socket tester -V.A.G 1537/ A-
⇒ ["5.4.3 Final control diagnosis trailer detector control unit J345", page 301](#).*

The trailer detector control unit -J345- detects from a power draw of minimum 5 W⁴⁾ the "trailer operation" and transfers this information to various control units via the CAN databus.

The trailer detector control unit -J345- is supplied with information (light control) from the onboard supply control unit -J519- and convenience system central control unit -J393- via the CAN.

4) At least the turn signal and brake light must be switched on, in order to detect "trailer operation".

Fault detection and fault display:

The trailer detector control unit -J345- is equipped with self-diagnosis, which is designed to ease fault finding.

For fault finding, use the vehicle diagnosis, testing and information system -VAS 5051A- in "guided fault finding" mode.

5.4.1 Removing and installing trailer detector control unit -J345-

Special tools and workshop equipment required

- ◆ Torque wrench -V.A.G 1783-

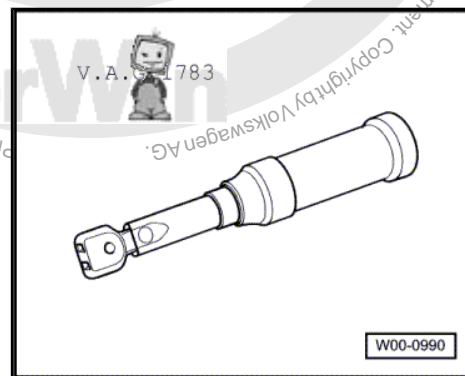



Removing:

- Switch off ignition and all electrical consumers and pull out ignition key.
- Remove left side panel trim in luggage compartment => General body repairs, interior; Rep. Gr. 70 ; Removing and installing load and luggage compartment trim; Trim, luggage compartment, sideways .
- Release connectors -2- and pull off trailer detector control unit -J345- .



Note

The connector number on the trailer detector control unit -J345- shown in the figure depends on vehicle equipment and may vary.

- Remove securing bolts -1- and take trailer detector control unit -J345- with the bracket out of the vehicle.
- Remove securing bolts -arrows- and take trailer detector control unit -J345- off bracket.

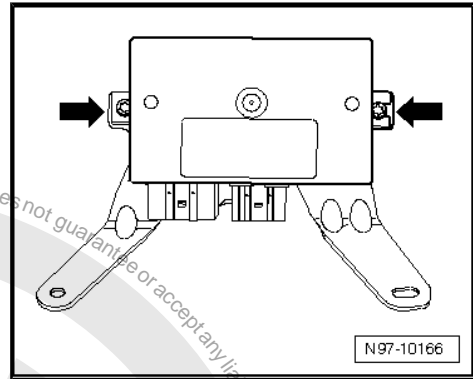
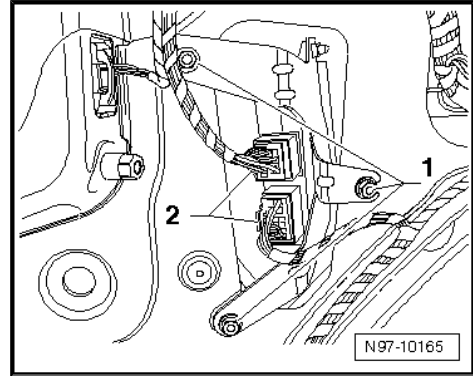

Installing:

Installation is performed in the reverse order of installation; when doing this, note the following:

- Tighten threaded connections to specified torque settings => [page 307](#) .



Note

After installing a new trailer detector control unit -J345- it must be coded => [page 300](#) .

5.4.2 Coding trailer detector control unit - J345

- Connect Vehicle Diagnosis, Testing and Information System -VAS 5051A- => [page 281](#) .
- Select "guided fault finding" in Vehicle Diagnosis, Testing and Information System -VAS 5051A- .
- Using the "Go to" key, select "Function/component selection" and the following menu items one after the other:
 - ◆ Body
 - ◆ General Body Repairs
 - ◆ 01 - On Board Diagnostic capable systems
 - ◆ Trailer detector
 - ◆ Function
 - ◆ Coding trailer detector control unit



5.4.3 Final control diagnosis trailer detector control unit -J345-



Note

- ◆ The trailer detector control unit -J345- detects from a power draw of minimum 5 W⁴⁾ the "trailer operation".
- ◆ To check use plug socket tester -V.A.G 1537/A- .

Special tools and workshop equipment required

- ◆ Plug socket tester -V.A.G 1537/A-⁵⁾

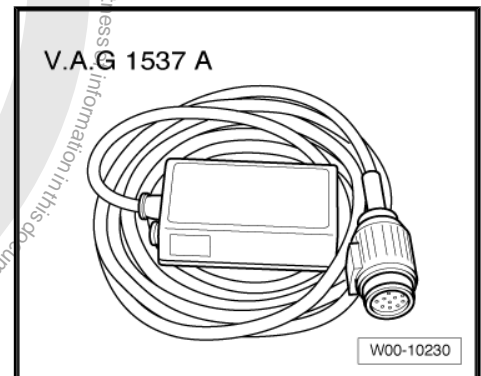

5) After a few minutes the plug socket tester -V.A.G 1537/A- gets to hot and switches off automatically. After a cooling period the plug socket tester -V.A.G 1537/A- works again perfectly.

- Connect the plug socket tester -V.A.G 1537/A- .
- Connect Vehicle Diagnosis, Testing and Information System -VAS 5051A- ⇒ [page 281](#) .
- Select "guided fault finding" in Vehicle Diagnosis, Testing and Information System -VAS 5051A- .
- Using the "Go to" key, select "Function/component selection" and the following menu items one after the other:
 - ◆ Body
 - ◆ General Body Repairs
 - ◆ 01 - On Board Diagnostic capable systems
 - ◆ Trailer detector
 - ◆ Function
 - ◆ Trailer detector control unit - Final control diagnosis



6 Wiring harness and connector repairs

6.1 Safety instructions



Caution

For repair work on airbag and seat belt tensioner wiring harnesses, only contacts, connectors and wiring designed specifically for this purpose may be used ⇒ Parts catalogue (ETKA)!

- ◆ Observe country-specific regulations.
 - ◆ Observe vehicle stickers indicating high voltage components. Before carrying out repairs, discharge residual voltage.
 - ◆ Wires from airbag and belt tensioner wiring harness must only be repaired using wiring harness repair set -V.A.G 1978-.
- ⇒ Operating instructions wiring harness repair set -V.A.G 1978-
⇒ General body repairs interior; Rep. Gr. 69

6.2 General notes concerning repairs to vehicle electrical system



Caution

Disconnecting and connecting the battery as described in the Workshop Manual ⇒ [page 29](#).

- ◆ Observe current notes (also notes concerning removing and installing components) in workshop manuals and in the Technical Service Handbook.
 - ◆ Yellow wiring and sections of wiring harness wrapped in yellow tape indicate a prior repair.
- ⇒ Operating instructions wiring harness repair set -V.A.G 1978-
- ◆ Before beginning repairs to a wiring harness, first rectify the cause of the damage, e.g. sharp edges on a body part, defective electrical consumer, corrosion.
 - ◆ Disconnecting the battery earth strap (open circuit) provides a safe working environment for repairs to the electrical system. The battery positive wire need only be disconnected for removal of the battery.
 - ◆ If possible, do not loosen any earth wires from the body (danger of corrosion).

6.3 Notes on repairs to wiring harness and connectors

Supplementary notes on repair of CAN bus wiring ⇒ [page 303](#)

- ◆ Soldering is not permitted for repairs to vehicle wiring.
- ◆ Never repair any heat-shrink connections. If necessary, lay wiring parallel to the defective wiring.
- ◆ Onboard supply wiring harnesses and connectors may only be repaired using wiring harness repair set -V.A.G 1978-.



⇒ Operating instructions wiring harness repair set -V.A.G 1978-

- ◆ Perform wiring harness repairs only with yellow wires. Mark repair locations with yellow tape.
- ◆ Shielded wires must not be repaired. In case of damage, they must be entirely replaced.

6.4 Supplementary notes on repair of CAN bus wiring

- ◆ An unshielded two-wire line -1- and -2- with a cross section of 0.35 mm² or 0.5 mm² is used for CAN bus wiring.
- ◆ The colour codes of the CAN bus wiring can be gleaned from the following table:

Drivetrain CAN, high	orange/black
Convenience CAN, high	orange/green
Infotainment CAN, high	orange/violet
CAN Low wire (all)	orange/brown

- ◆ Perform wiring harness repairs only with yellow wires. Mark repair locations with yellow tape.
- ◆ When repairs are performed, both bus wires must have the same length. When wires -1- and -2- are twisted together, the twist spacing should be A=20 mm.
- ◆ No section of wiring greater than B=50 mm, e.g. in the vicinity of heat-shrink sleeves -arrow-, should not be twisted.

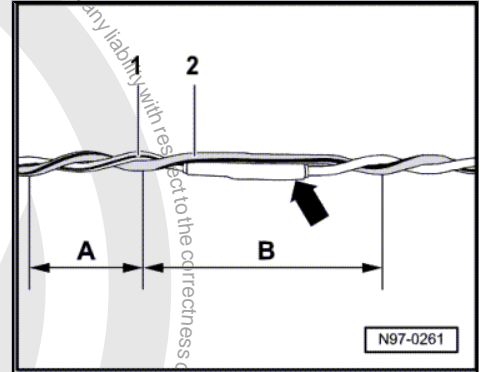



6.5 Wiring harness repair set -V.A.G 1978-

- Repairs to wiring harnesses and connectors of the onboard electrical supply system should only be carried out using wiring harness repair set -V.A.G 1978- .

- Included with the wiring harness repair set -V.A.G 1978- is a set of operating instructions, which provides comprehensive information on how to conduct repairs.

- Further information, e.g. removal and installation of parts and components, appears in the relevant workshop manual.

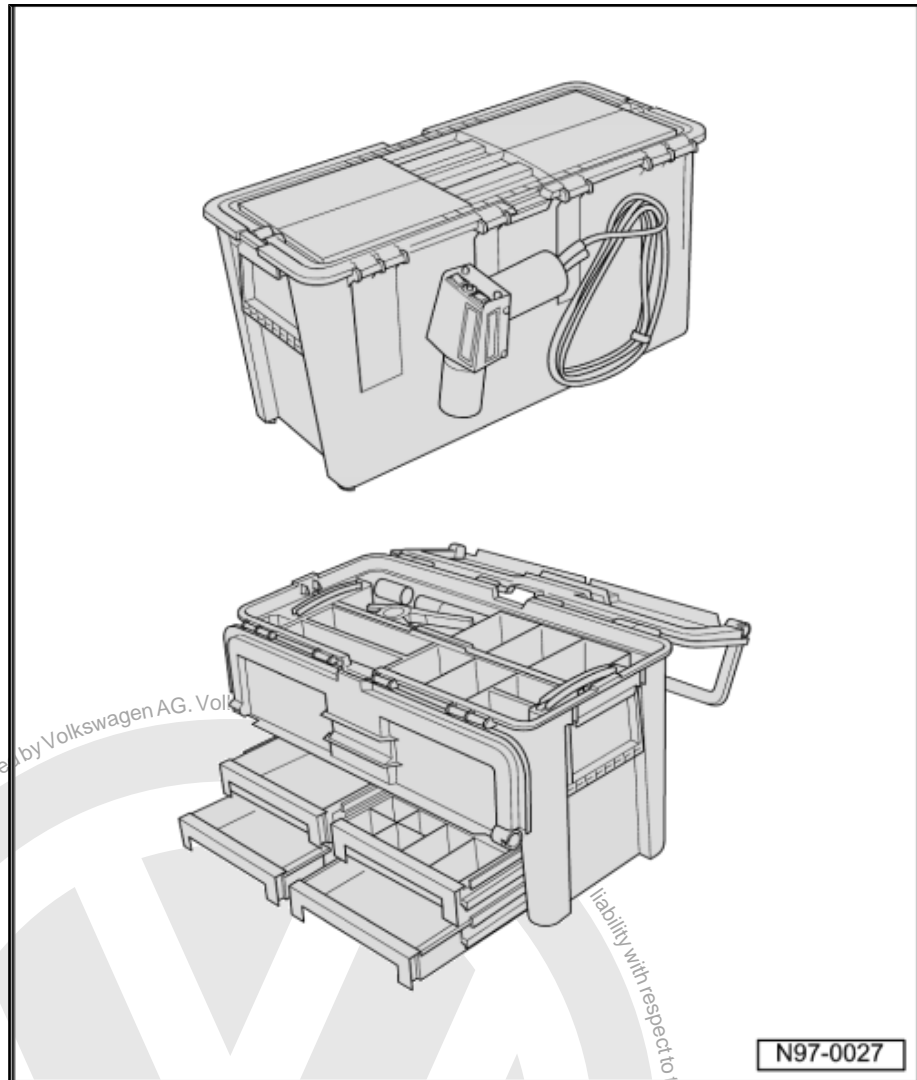

Protected by copyright. Copying for private or commercial purposes, in part or in whole, is not permitted unless authorised by Volkswagen AG. Volkswagen



liability with respect to the correctness of information in this document. Copyright by Volkswagen AG.



7 Renewal of aerial wiring

A new repair concept has been developed for repair work on aerial wires. Now connecting wires in different lengths and various adapter cables are available as replacement parts instead of a complete aerial wire.

7.1 General description

- ◆ Aerial wires must not be repaired, but if repair is required, they must be replaced only by connecting wires and adapter cables offered as genuine parts.
- ◆ Replacement parts can be found in the electronic parts catalogue: Special catalogue; Electrical connections; Genuine accessories; Subgroup 35 from illustration No. 035-20.
- ◆ These genuine parts are suitable for all aerial wires and wire diameters which may need to be replaced.
- ◆ No provision has been made for replacement of individual aerial connectors in the event of repair.
- ◆ The wires can be used retroactively for all VW models, with all installed aerial wire diameters.
- ◆ All adapter and connection wires are suitable for all transmitter and receiver signals.
- ◆ This repair method can also be used for testing or retrofitting.

7.2 Assembly overview - an aerial wire

Example: Aerial wire between radio and aerial is defective. The following wires are required for the repair:

- 1 - Adapter cable, to radio connection. Length approx. 30 cm.
- 2 - Connecting wire, available in different lengths.
- 3 - Adapter cable, to aerial connection. Length approx. 30 cm.

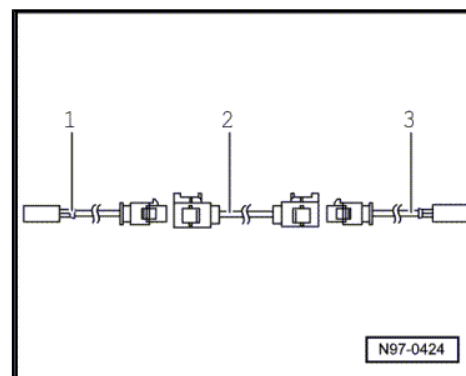

7.3 Installing a new aerial wire



Note

Note that the total length of an aerial wire, depending on vehicle equipment level, can be divided into sections by aerial diversity control unit, traffic information control unit or aerial amplifier. Only the defective section of aerial wire must be replaced.

- Pull defective aerial wire connections off units.
- Determine the routing of the defective aerial wire in vehicle and measure the total length of the aerial connecting wire to be replaced.



The total length of aerial connecting wire is the sum of the length of adapter cables required -1- and -3- and the connecting wire -2-.

- To determine the length of connecting wire required, subtract 60 cm from the measured total length of aerial connecting wire -2-.
- Procure the required adapter cables -1- and -3- and connecting wire -2- at the calculated length as genuine parts from the parts catalogue (ETKA).
- Cut off connectors of defective aerial wire.

The remainder of the defective aerial wire remains in the vehicle.

- Connect adapter cables -1- and -3- to equipment in vehicle.
- Route and secure connecting wire -2- parallel to the old aerial wire.

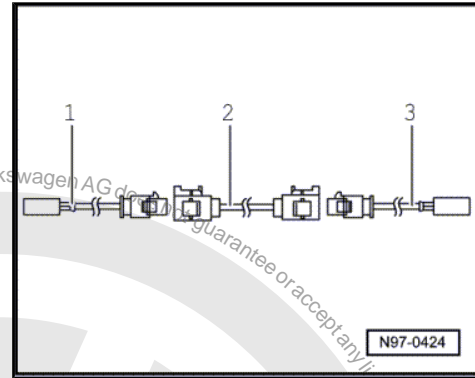

Note

Do not kink or excessively bend aerial wires! The bending radius must not be below 50 mm.

- Connect connecting wire to adapter cables.
- Perform a functional check.



8 Torque settings: Cables

8.1 Torque settings: Electronics box in left side of engine compartment

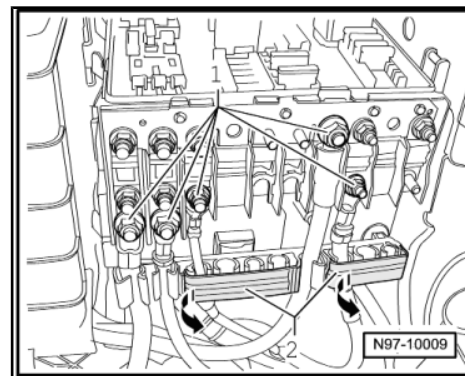

Threaded connections		Torque settings
Securing nuts -1-	M5 (AF 8)	4 Nm
Securing nuts -1-	M6 (AF 10)	6 Nm

8.2 Torque settings trailer detector control unit -J345-

Threaded connections		Torque settings
Securing bolts bracket to body		2 Nm
Securing bolts control unit to bracket		2 Nm

