



**Self-study Programme 447**

**The Polo 2011**



This self-study programme provides information on the design and function of the Polo 2011.

The individual chapters on the assemblies contain references to further self-study programmes which offer more detailed information on the design and the function of individual vehicle components.

The self-study programmes help you to understand the technical contexts more easily, and supplement the testing, adjustment and repair instructions.

Self-study programme  
on the launch of the vehicle

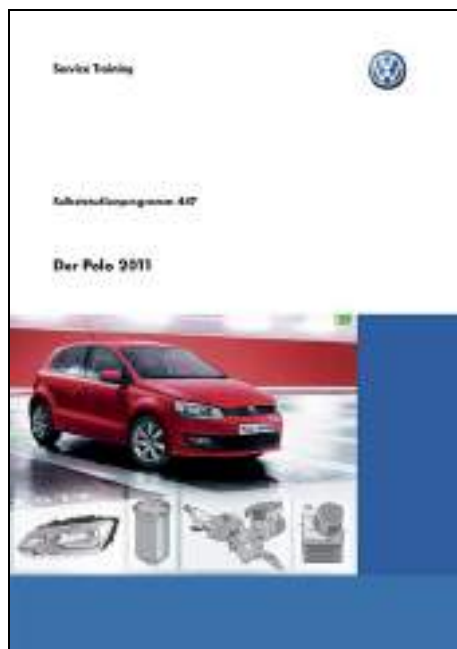

S447\_119

Self-study programme  
on the design and function



S447\_121



S447\_123



S447\_125

**The self-study programme portrays the design and function of new developments!**  
The contents will not be updated.

For current testing, adjustment and repair instructions, refer to the relevant after sales literature.



**Attention  
Note**

# Contents



<b>Introduction</b> .....	<b>4</b>
<b>Body</b> .....	<b>8</b>
<b>Occupant Protection</b> .....	<b>14</b>
<b>Engines</b> .....	<b>15</b>
<b>Power Transmission</b> .....	<b>20</b>
<b>Running Gear</b> .....	<b>22</b>
<b>Heating and Air Conditioning</b> .....	<b>34</b>
<b>Electrical System</b> .....	<b>36</b>
<b>Radio and Navigation</b> .....	<b>40</b>
<b>Convenience Electronics</b> .....	<b>42</b>



# Introduction

## The Polo 2011

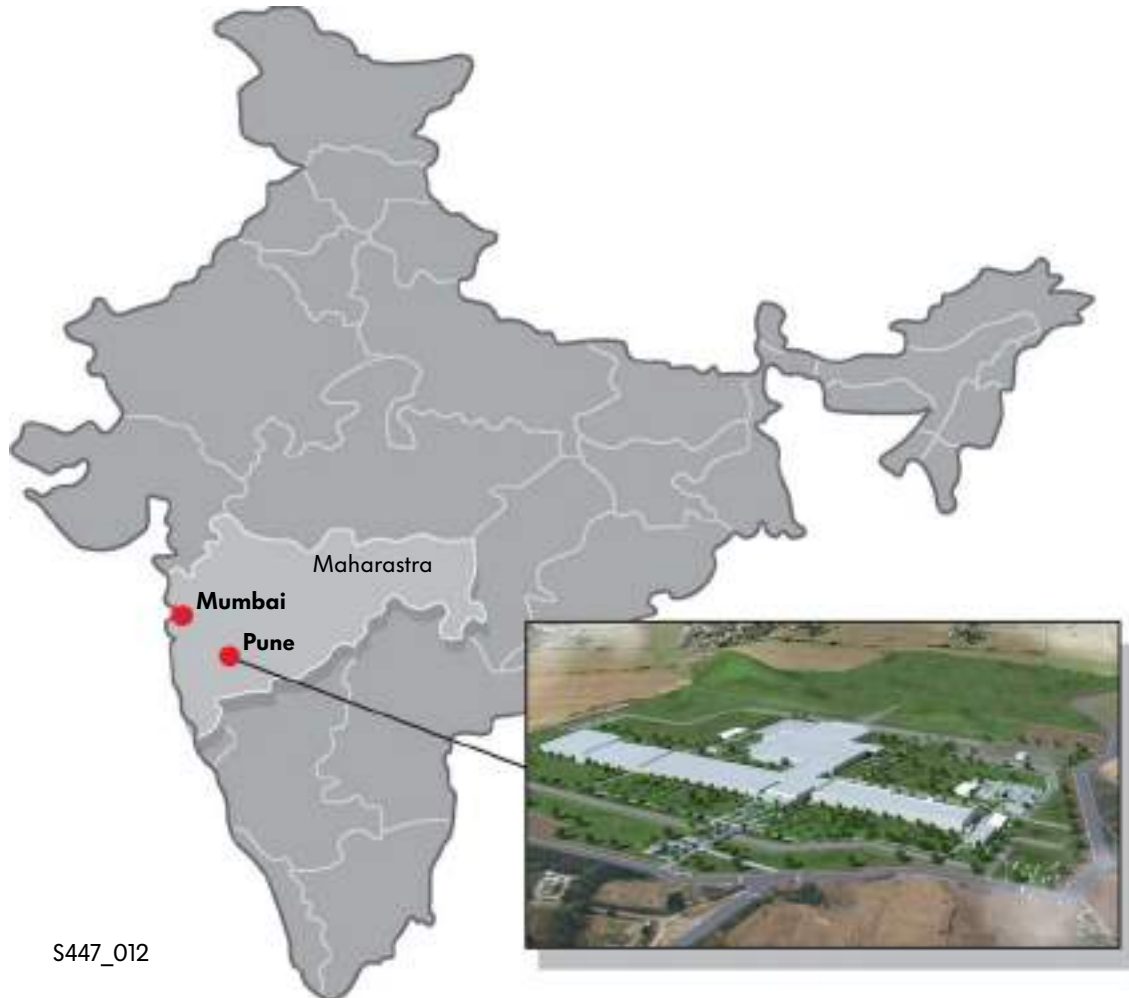

S447\_012

The Polo 2011 will be the first Volkswagen vehicle to be manufactured in the new production plant established in 2010 in Pune in the state of Maharashtra. In this case, complete vehicle manufacturing encompasses the press shop, the body shop and the paint shop, up to and including assembly.

Based on the Polo which is available in Europe and the consistent use of technical modules within the current Volkswagen technology, the model has been further developed for the Indian market and has been adapted to the market's specific requirements.

In this regard, the Polo 2011 sets new standards in terms of:

- Sporty and modern design
- Outstanding practicality and comfort
- Low consumption thanks to the use of modern petrol engines and common rail diesel engines

The table shows the important features within the Trendline, Comfortline and Highline equipment lines.



S447\_061

Equipment	Trendline	Comfortline	Highline
Electronic immobiliser	x	x	x
3-point automatic seat belts in the front	x	x	x
Two 3-point automatic seat belts in the rear	x	x	x
Lap belt in the centre	x	x	x
Height adjustable front head restraints	x	x	x
2 rear head restraints	x	x	x
Folding rear seat bench and backrest	x	x	x
3-spoke steering wheel	x	x	x
Partially galvanised body incl. 12-year anti-perforation warranty	x	x	x
Heavy duty running gear	x	x	x
Halogen headlights H4	x	x	x
4 doors	x	x	x
Electric power windows at the front	x	x	x
Central locking	x	x	x
Manual air conditioner	x	x	x
Power assisted steering	x	x	x
Luggage compartment cover		x	x
Electric power windows at the rear		x	x
Height adjustable driver seat		x	x
ABS			x
Airbag for the driver and front passenger			x
Fog lights			x
Rear fog light			x
Alloy wheels			x
Radio remote control for central locking			x
Multi-function display in the dash panel insert			x
Radio system with CD and MP3 player			x



# Introduction

## Technical data

### Exterior dimensions and weights

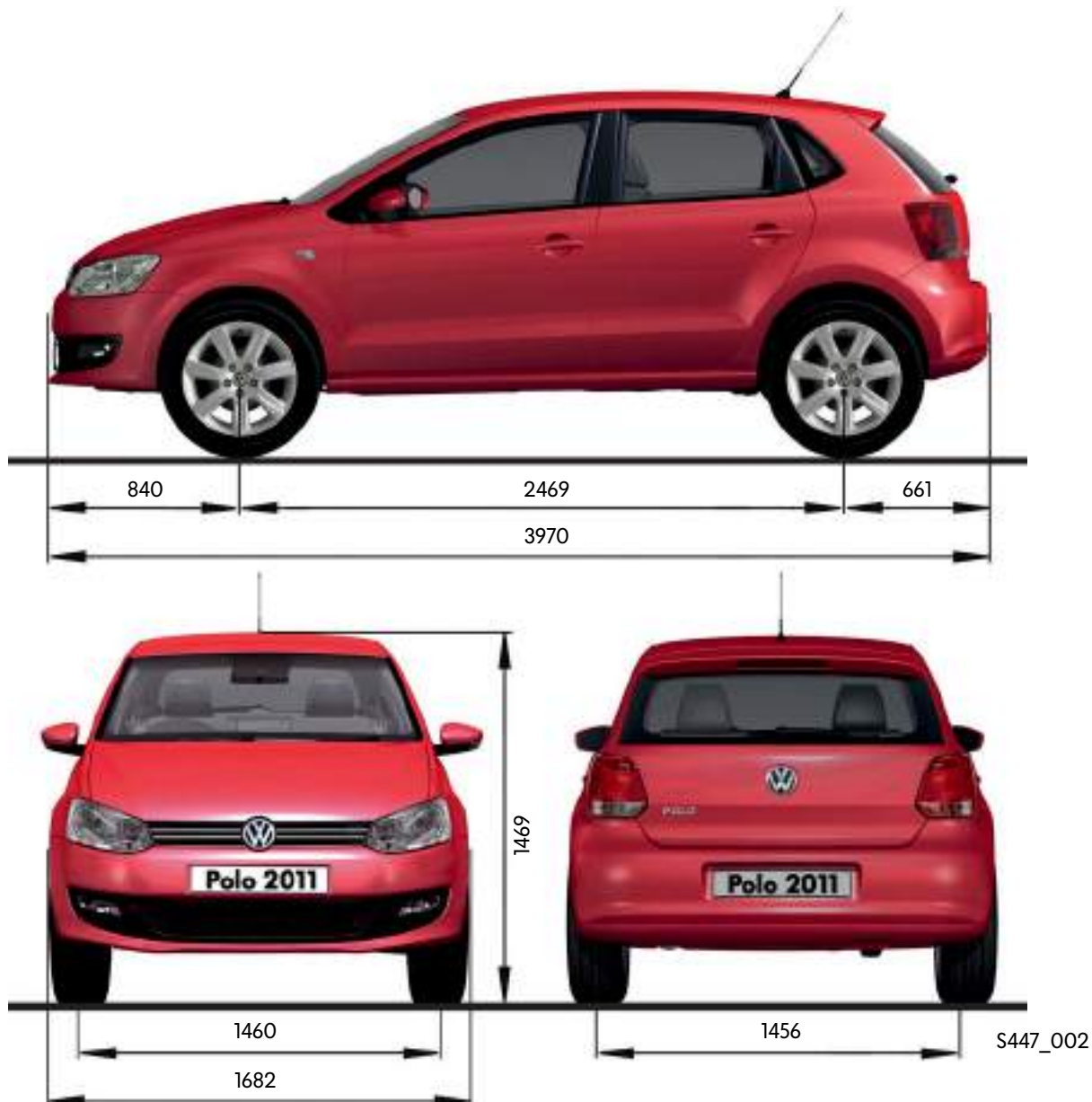

#### Exterior dimensions

Length	3970 mm
Width	1682 mm
Height	1469 mm
Wheelbase	2469 mm
Track width at front	1460 mm
Track width at rear	1456 mm

#### Weights/further data

Permissible GVW	1520 kg*
Kerb weight without driver	1024 kg*
Tank capacity	45 l
Drag coefficient	0.35 c <sub>d</sub> *

\* 1.2 ltr. 55 kW petrol engine with MQ 200, 4-door, Highline equipment



## Interior dimensions

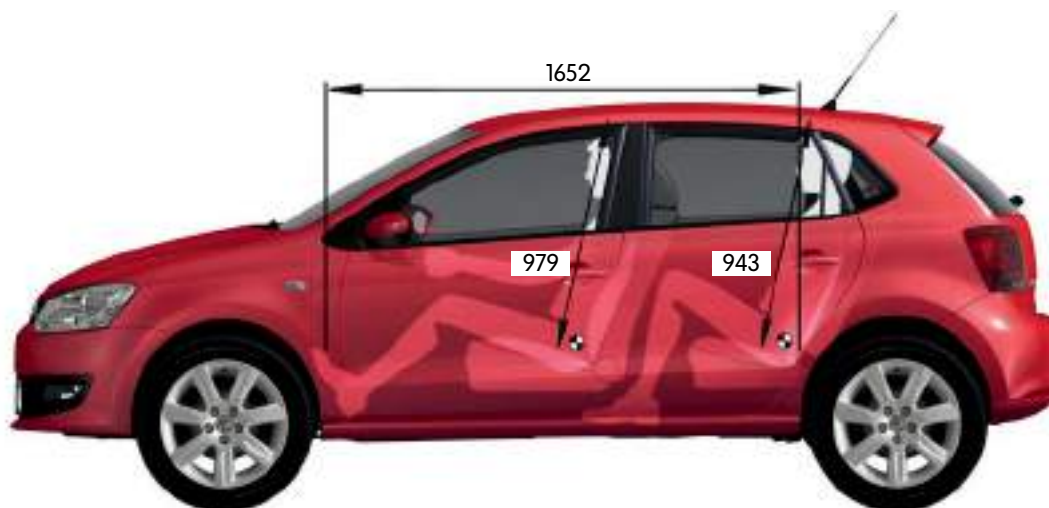

S447\_003



S447\_004

## Interior dimensions and volumes

Interior length	1652 mm
Luggage compartment volume	262l
Luggage compartment volume with rear seat backrest folded down	980l

Front headroom	979 mm
Rear headroom	943 mm
Width at shoulder height, front	1372 mm
Width at shoulder height, rear	1327 mm

# Body

## Body structure



S447\_111

High- and ultra high-strength steels are used to be able to meet the requirements of a stable vehicle structure. For the first time, the B-pillar in the Polo is also manufactured from die-quenched steel, as is already the case e.g. in the Golf. This has increased the stability of the passenger compartment without increasing weight. The passenger compartment serves as the survival space for the occupants.



No roof load is permissible due to the roof structure of the Polo 2011.

### Frontal crash

In order to achieve a stable link between the front longitudinal members, the transverse impact member has been manufactured from ultra high-strength steel. As a result of this, both longitudinal members are used to dissipate energy in the event of a frontal crash.



### Strength of the steel panels

- < 140 Mpa
- > 140-300 Mpa
- > 300-1000 Mpa
- > 1000 Mpa

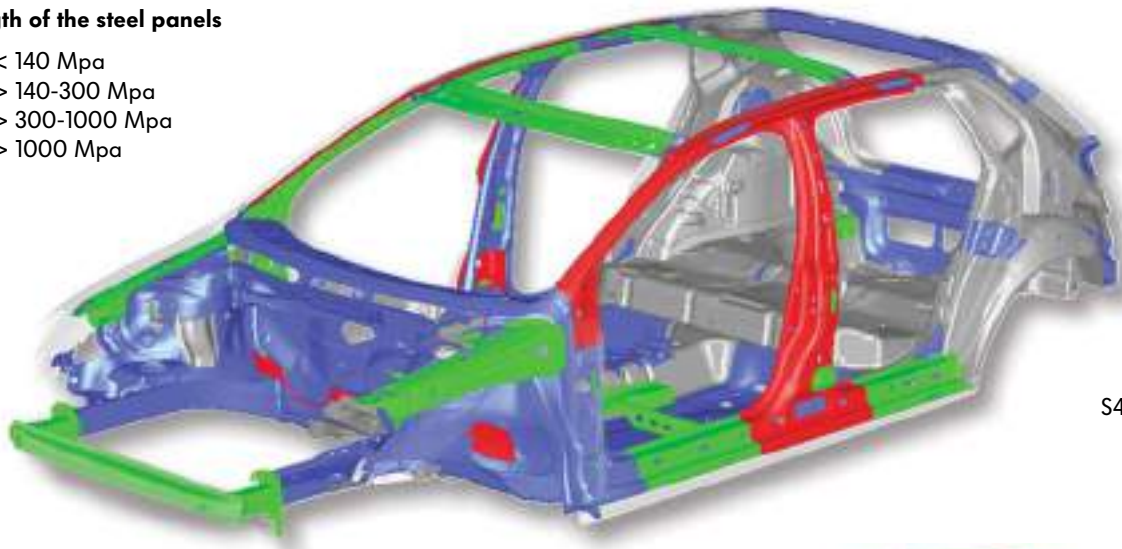

S447\_133

### Side crash

In the event of a side crash, the B-pillar and the doors are the most important structural components. Together, they absorb the main force of a lateral collision.

In terms of weight and component scope, the use of die-quenched steels has led to an efficient design. It enables maximum occupant protection without additional reinforcements. As the central load distributor, the B-pillar conducts the forces which occur to the sills and to the roof frame. By providing support to the opposite side of the vehicle, the seat cross member ensures additional passenger compartment stability.

In combination with the doors, which are reinforced with diagonally mounted impact bars, the crash energy is dissipated at an extremely high force level.

Both low intrusion velocities and low intrusion into the passenger compartment are achieved in this manner in the event of a side crash.

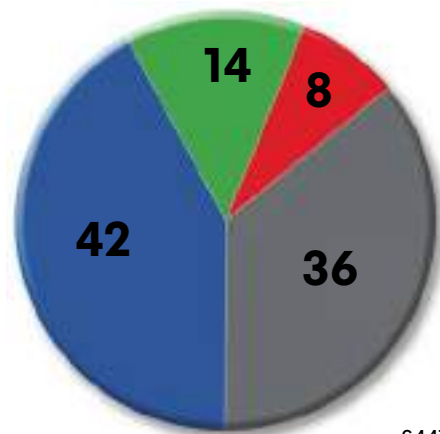

S447\_131

### Rear crash

The rear crash requirements made on the vehicle consist of the stability of the passenger compartment and the vehicle's rear end structure.

The rear axle geometry, the routing of the fuel filler neck and the fuel tank's position in front of the rear axle connection protect the fuel system in the event of a rear crash.



# Body

## Doors



The door shell is designed in one piece.  
Side impact bars are installed in the doors.

The window lifter is accessible after removing a plastic cover.

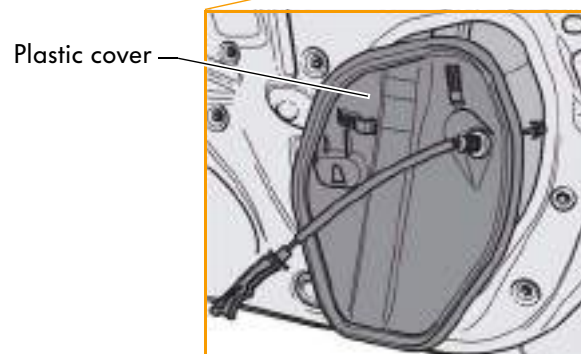
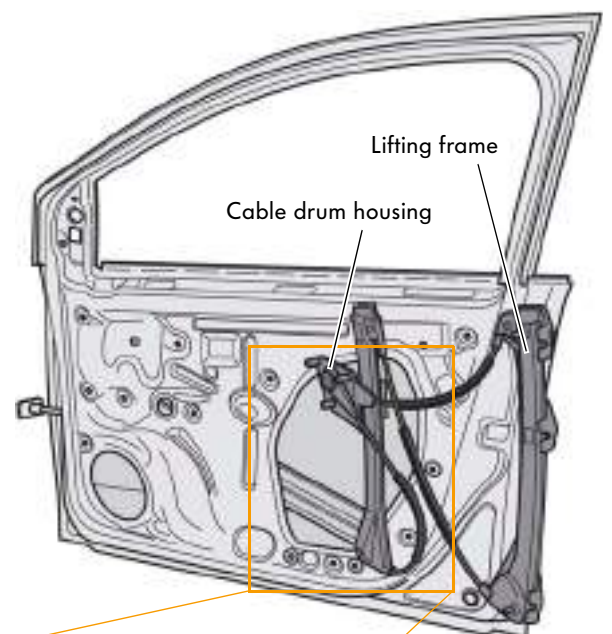

## Headlight module



The headlight module is equipped with a turn signal, side light, dipped beam and main beam headlight. A further turn signal is located in the wing. A H4 headlight is fitted as standard.

The headlights on the Polo 2011 can be removed using the vehicle tools. This is necessary as the bulbs can only be renewed when the headlights have been removed.

## Functions of the H4 headlight

### Side light



S447\_107

When the side light is switched on, only the side light bulb is lit.

### Dipped beam



S447\_103

When dipped beam is switched on, the dipped beam bulb and the side light bulb are lit.

### Main beam



S447\_109

When main beam is switched on, the main beam bulb, the dipped beam bulb and the side light bulb are lit.

### Turn signal



S447\_105



# Body

## Fog lights



S447\_101

Fog light

The Polo 2011 is optionally equipped with fog lights. These are located in the front spoiler.

## Rear lights

The rear lights on the Polo 2011 are designed in one piece. The tail light, brake light, turn signal, rear fog light, reversing light and reflector are integrated here. The rear fog light is located in the right-hand rear light and the reversing light in the left-hand rear light.

Bulb replacement is carried out by removing the entire rear light. It is secured in the side panel via a central nut.

### Left-hand rear light



### Right-hand rear light



## Interior equipment

### Front seats

Depending on the equipment line, three seat variants are available in the new Polo. These offer upholstered sections which are formed to the shape of the body. The Trendline, Comfortline and Highline variants each have their own distinct seat contours.



S447\_116



S447\_114

### Rear seat system

The Polo 2011 is equipped with a non-split and folding rear seat system as standard. A variant which can be split 40% to 60% is optionally available.





# Occupant Protection

## Safety equipment

### Airbag system



S447\_050







The Polo 2011 is optionally fitted with the following safety equipment:

- Driver airbag
- Front passenger airbag
- Three-point seat belts for the outer rear seats
- Lap belt for the centre seat

The airbag trigger system consists of an airbag control unit in the front area of the frame tunnel with three internal acceleration sensors - two sensors in the vehicle longitudinal direction and one in the transverse direction.

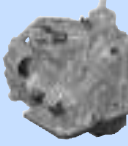

## Engine/gearbox combinations

<p>Petrol engine</p>	<p>1.2ltr. 55kW SRE engine</p> 	<p>1.6ltr. 77kW SRE engine</p> 	<p>1.2 ltr. 55kW CR TDI engine</p> 
<p>Diesel engine</p>			
<p>5-speed manual gearbox MQ200-5F 02T</p>	 <p>5-speed</p>	 <p>5-speed</p>	
<p>5-speed manual gearbox MQ250-5F 02R</p>			 <p>5-speed</p>
<p>6-speed automatic gearbox AQ250-6F 09G</p>		 <p>6-speed</p>	



# Engines

## 1.2ltr. 55kW engine with intake manifold injection

This 1.2l engine is the entry-level engine in the Polo 2011.

### Technical features

- Wheel housing air filter
- Camshaft driven via a chain
- Split cylinder block
- Crankshaft drive with balancer shaft
- Cross-flow cooling in the cylinder head
- Oil filter positioned vertically
- Non-return fuel system
- Crankcase breather and ventilation system
- Single-spark ignition coils with integrated final output stage



S447\_129



Further information on this engine can be found in self-study programme No. 260 "The 1.2 ltr. 3-cylinder petrol engines".

### Technical data

Engine code	CJLA
Type	3-cylinder in-line engine
Displacement	1198 cm <sup>3</sup>
Bore	76.5 mm
Stroke	86.9 mm
Valves per cylinder	4
Compression ratio	10.0 : 1
Maximum output	55 kW at 5400 rpm
Maximum torque	110 Nm at 3750 rpm
Engine management	Simos 9.1
Fuel	Premium gasoline RON 91 (at least RON 87, but reduced output)
Exhaust gas treatment	Three-way catalytic converter with Lambda control
Emissions standard	Bharat stage 4*/EU4

### Output and torque curves

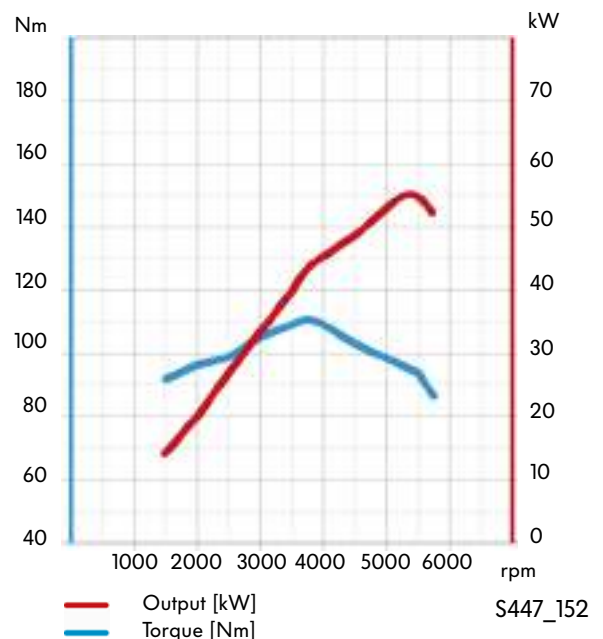

S447\_152

\* Legally prescribed emissions stage in India

# 1.6ltr. 77kW engine with intake manifold injection

This engine has been fitted in various vehicle models since model year 2007.

## Technical features

- Grey cast iron cylinder block
- Camshaft driven via a chain
- Reduced main bearing diameter
- Sheet metal oil pan
- Pre-heating for the crankcase breather system integrated into the cooling system
- Non-return fuel system
- Exhaust manifold and three-way catalytic converter combined to form a single module



S447\_151



Further information on this engine can be found in self-study programme No. 296 "The 1.4 ltr. and 1.6 ltr. FSI engine with timing chain".

## Technical data

Engine code	CLSA
Type	4-cylinder in-line engine
Displacement	1598cm <sup>3</sup>
Bore	76.5mm
Stroke	86.9mm
Valves per cylinder	4
Compression ratio	10.5 : 1
Maximum output	77kW at 5400 rpm
Maximum torque	153Nm at 3800 rpm
Engine management	Magneti Marelli 7GV
Fuel	Premium gasoline RON 91 (at least RON 87, but reduced output)
Exhaust gas treatment	Main catalytic converter with Lambda control
Emissions standard	Bharat stage 4*/EU4

## Output and torque curves

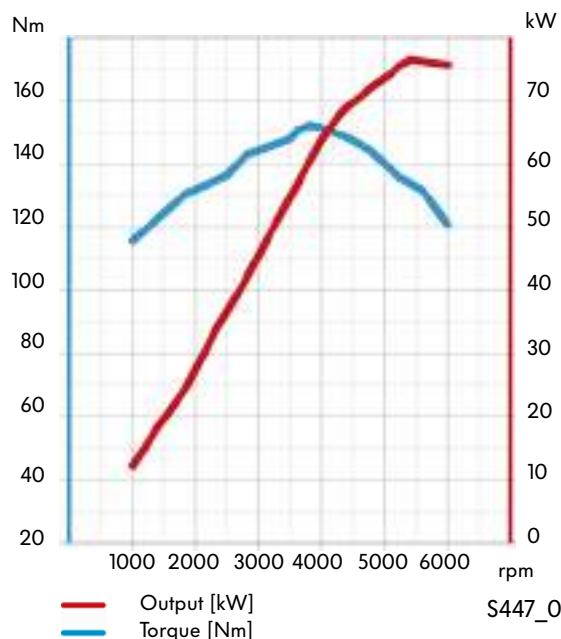

S447\_054

\* Legally prescribed emissions stage in India

# Engines

## 1.2ltr. 55kW CR TDI engine

Based on the 1.6 ltr. TDI engine introduced at the beginning of 2009, a new 3-cylinder engine has been created in the form of the 1.2 ltr. 55 kW TDI engine. The engine's common rail fuel injection system has been developed together with Delphi. It achieves a maximum injection pressure of 1800bar and enables low fuel consumption and low pollutant emissions with outstanding dynamics and good comfort.

### Technical features

- Common rail fuel injection system with solenoid valve-controlled injectors
- Adjustable turbocharger
- Exhaust gas recirculation module consisting of an exhaust gas recirculation valve and engageable exhaust gas recirculation cooler
- Oxidising catalytic converter
- Balancer shaft module



S447\_046



Further information on this engine can be found in self-study programme No. 465 "1.2 ltr. TDI Engine with Common Rail Injection System".

### Technical data

Engine code	CFWA
Type	3-cylinder in-line engine
Displacement	1199 cm <sup>3</sup>
Bore	79.5mm
Stroke	80.5mm
Valves per cylinder	4
Compression ratio	16.5 : 1
Maximum output	55kW at 4200 rpm
Maximum torque	180 Nm at 2000 rpm
Engine management	Delphi DCM 3.7
Fuel	Diesel, DIN EN 590*
Exhaust gas treatment	Exhaust gas recirculation, oxidising catalytic converter
Emissions standard	Bharat stage 4**/EU4

### Output and torque curves

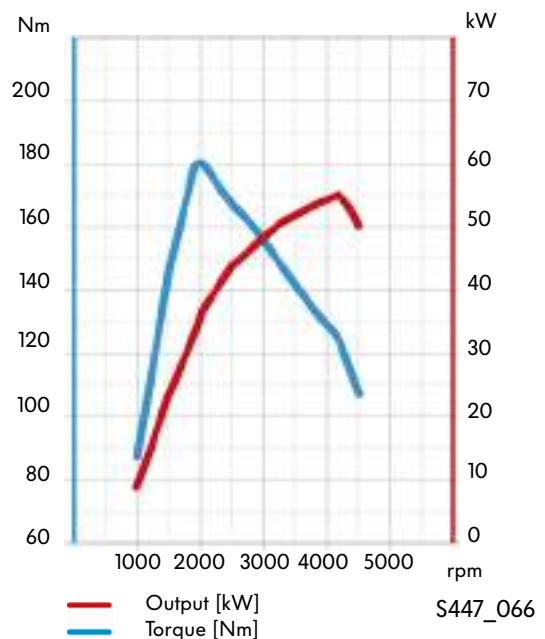

S447\_066

\* Deviating fuel standards possible

\*\* Legally prescribed emissions stage in India

## Fuel filter in the 1.2 ltr. TDI engine

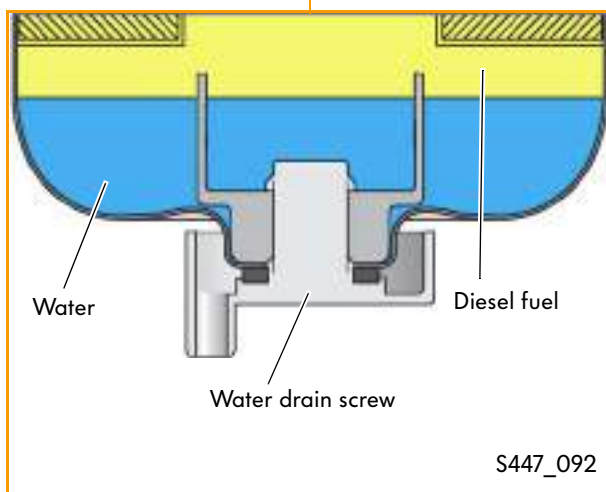
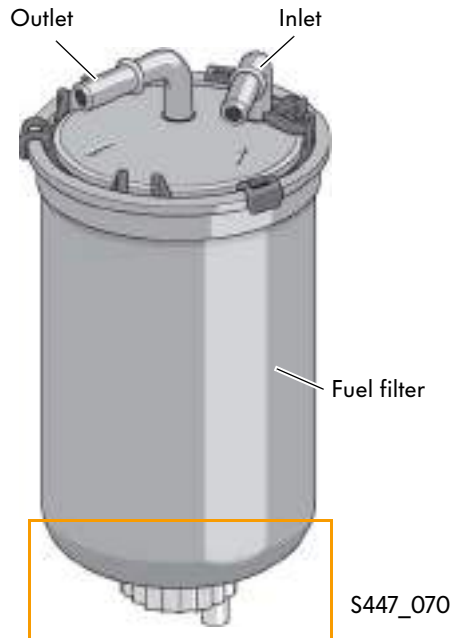

Fuel filters have the task of keeping contaminants and water in the diesel fuel away from the fuel injection system components. The high-precision components, such as e.g. the high-pressure pump and the injectors, can be damaged or their function impaired by even the most minute particles of dirt.

Water normally enters the fuel due to condensation or when fuelling the vehicle. As a result of its higher weight in comparison with the fuel, the water primarily collects in the base area of the filter.

If the water content in the diesel fuel is too high, the risk of the water's causing corrosion in the fuel injection system's components and thereby damaging them is run.

The fuel filter fitted in the fuel system of the 1.2 ltr. TDI engine in the Polo 2011 has a water drain screw on the base of the filter housing.

The water drain screw is used to drain the water which has collected in the fuel filter at regular intervals.



To drain the fuel filter, please note the instructions in the Workshop Manual and in the Maintenance Manual!

# Power transmission

## 6-speed automatic gearbox 09G

The 6-speed automatic gearbox 09G is a compact, light, electronically controlled gearbox for transverse mounting.

This gearbox offers the following features:

- Max. torque of 250 Nm
- Weight of 82 kg
- Length of approx. 350 mm
- Torque converter with torque converter lock-up clutch
- Automatic and Tiptronic modes



S447\_011

The electrohydraulic design is based on that of 6-speed automatic gearbox 09D. The six forwards gears and the reverse gear are implemented via the arrangement of a simple planetary gear set with a downstream double planetary gear set (Ravigneaux planetary gear set). The planetary gear sets are arranged according to the Lepelletier principle.

The automatic gearbox control unit regulates the pressure built-up by the multi-plate clutches and multi-plate brakes via modulation valves. The modulation valves enable delayed pressure build-up. The result is rapid response and jolt-free gear shifting.



For more detailed information on the 6-speed automatic gearbox, please refer to self-study programme 309 "6-speed automatic gearbox 09G/09K/09M".



## 5-speed manual gearbox 02T

This gearbox offers the following features:

- Low weight
- CO<sub>2</sub>-optimised gear ratios
- Toothing partially ground (5th gear and axle)
- Torque capacity up to 170 Nm



S447\_065



## 5-speed manual gearbox 02R

This gearbox offers the following features:

- Further developed from the 02J gearbox
- CO<sub>2</sub>-optimised gear ratios
- Torque capacity up to 250 Nm



S447\_063

# Running gear

## Overview

The running gear in the Polo 2011 is essentially based on the running gear fitted in the Polo 2004. It offers an increased track width in comparison with the Polo 2004. The running gear in the Polo 2011 has additionally been adapted to meet the increased requirements arising from local conditions, such as e.g. the state of the roads and climatic conditions.



S447\_043

The running gear is characterised by the following features:

- Ride height raised 15mm in comparison with the Polo 2010
- Rear axle with V profile
- Bosch 8.2 brake system with ABS
- 14" steel wheels and 15" alloy wheels



Further information on the Polo 2011 can be found in self-study programme No. 444 "The Polo 2010".

## Front axle



S447\_137

The front axle is a McPherson strut axle. The ride height has been increased by 15mm in comparison with the Polo 2010. The front axle has a large caster angle, as a result of which stable straight line running is achieved.

## Rear axle



S447\_135

The rear axle is a torsion beam axle. The ride height has been increased by 15mm in comparison with the Polo 2010. Deep-groove ball bearings are fitted as wheel bearings.



# Running gear

## Front brakes

The front axle on the Polo 2011 is fitted with internally ventilated disc brakes with a brake disc size of 256 mm diameter x 22 mm thickness.

The front brakes are 3rd generation single-piston floating caliper brakes. The brakes are additionally equipped with an integrated swivel bearing.



S447\_073



## Rear brakes

The rear axle on the Polo 2011 is fitted with brake drums measuring 200 mm diameter x 40 mm thickness.

The wheel brake cylinders have a piston diameter of 17.46 mm.



S447\_075

## Brake servo



S447\_077

The Polo 2011 is fitted with an 8.5" brake servo. It has a brake master cylinder with an integrated brake light sensor. The characteristic curve of the brake servo is linear (single rate).

## Bosch 8.2 brake system with ABS

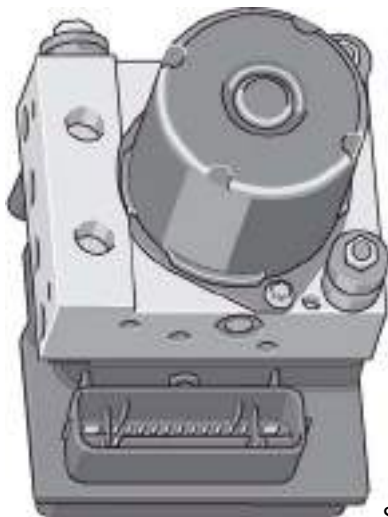

S447\_068

The Polo 2011 is fitted with the latest traction control system generation (Bosch 8.2).

The essential features include:

- Smaller component dimensions
- Reduced weight
- No EDL
- Emergency hazard warning flashing on braking in excess of  $7 \text{ m/s}^2$
- ABS (Highline equipment)

# Running gear

## Electromechanical power steering system

Electromechanical power steering system steering assistance is carried out via an electric motor on the steering column. The electromechanical power steering system is compatible with each engine/gearbox combination.

The steering comprises the following components:

- Steering wheel
- Steering column switch
- Steering column
- Steering moment sender G269
- Worm gear
- Electromechanical power steering motor V187
- Power steering control unit J500
- Universal joint shaft
- Mechanical steering box

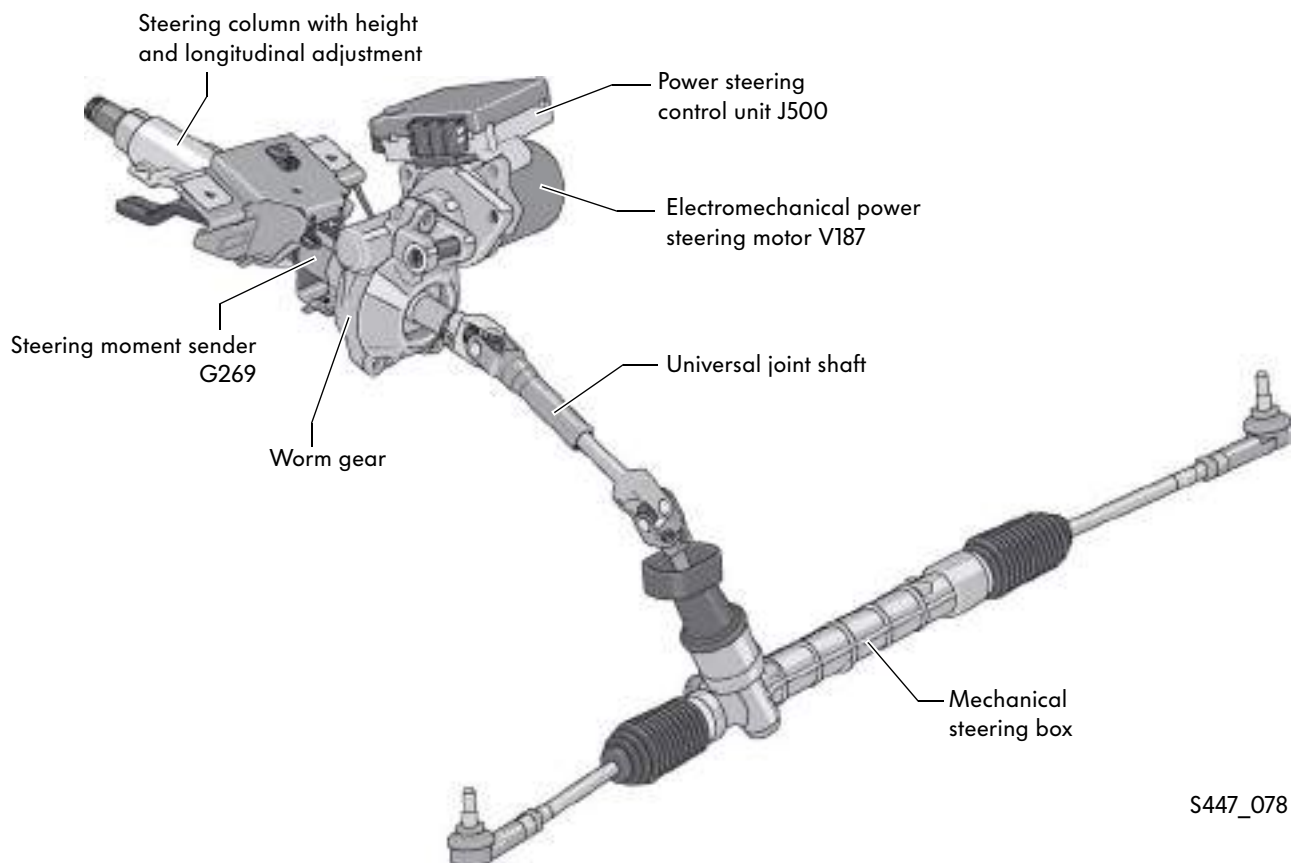

S447\_078



Further information on the electromechanical power steering system can be found in self-study programme No. 225 "The electro-mechanical power steering system".



## The advantages of the electromechanical power steering system

One particular advantage of the electromechanical power steering system compared with hydraulic steering systems is that the hydraulic system can be omitted. This results in further advantages such as:

- The hydraulic components are omitted, e.g. servo oil pump, hoses, oil reservoir, filter
- The hydraulic fluid is omitted
- Installation space is saved
- Low noise development
- Energy reduction
- The complex hoses and cables are omitted
- Robust
- Maintenance-free

A considerable reduction in energy is achieved. Unlike the conventional hydraulic steering which requires a constant volumetric flow, the electromechanical power steering only consumes energy when the steering is actually used. The fuel consumption is reduced due to this on-demand power consumption.



The driver has an optimal driving feel in any situation:

- The system provides the driver with steering assistance related to the driving conditions via a worm gear drive driven by an electric motor.
- It offers good straight line running. The steering is returned to the straight ahead position with active support from the electromechanical power steering.
- Via the steering components, the system provides the driver with a feel for the existing road surface contact.
- Direct but gentle response to steering commands is implemented thanks to the electromechanical power steering.
- The driver does not feel any unpleasant steering reactions on uneven road surfaces.



The fuel saving is up to 0.2 litres every 100 kilometres.

# Running gear

## The electromechanical power steering and its components

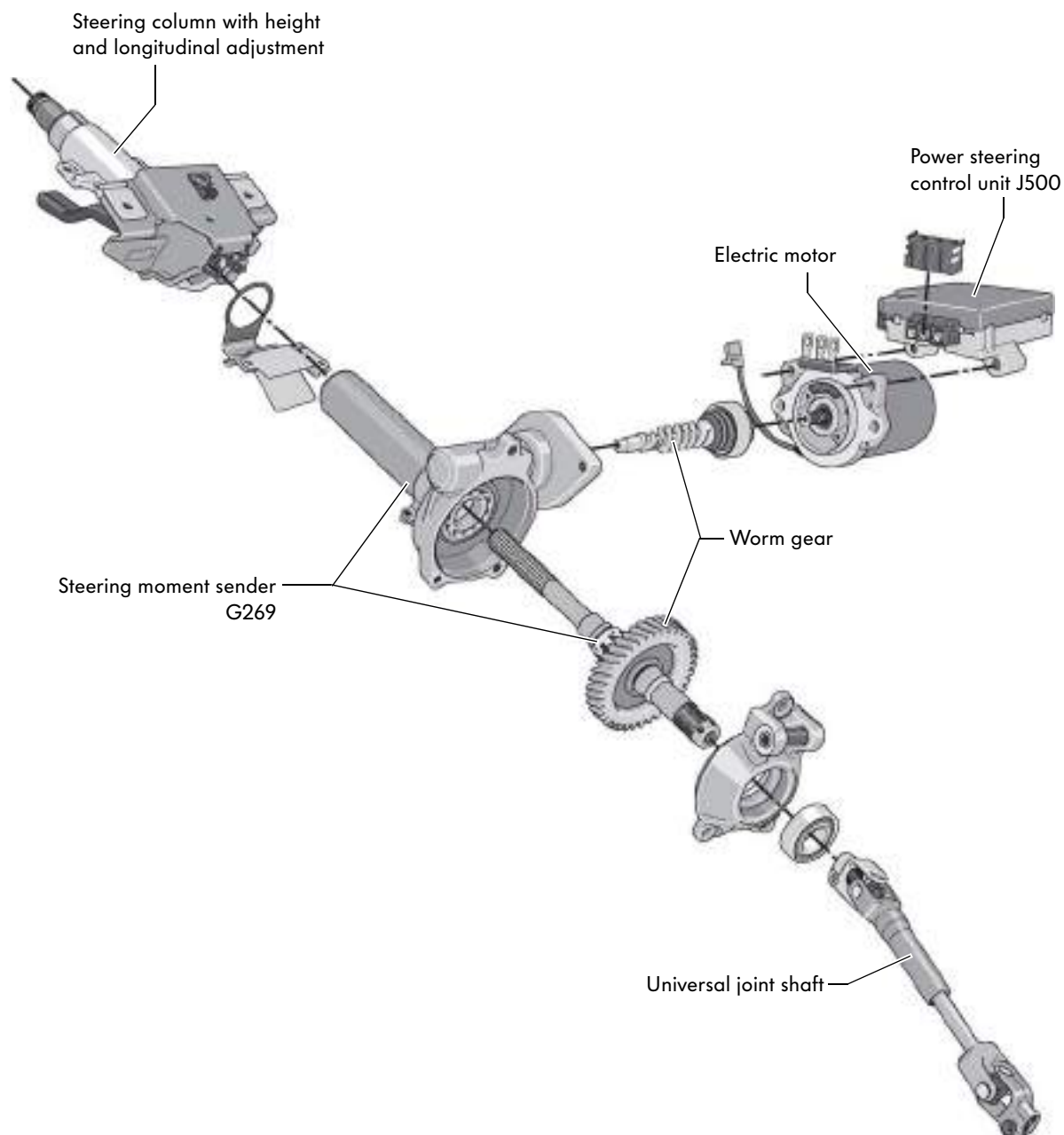

S447\_080

## Steering column

### Steering column adjustment

The steering column offers mechanical height and longitudinal adjustment. For optimal adjustment to the driver's requirements, it can be adjusted vertically and longitudinally by 45 mm. By actuating the adjustment lever, the clamping plate set is released and tightened for steering column height and longitudinal adjustment.

The advantage: infinite adjustment with high retention forces is possible.

### Steering assistance

In the electromechanical power steering system, steering assistance takes place on the steering column upstream of the universal joint shaft. The entire steering assistance system has been combined to form a compact unit. All components such as the control unit, the electric motor and the sensor required for steering form part of this unit and are located directly on the steering column. Complex line routing is omitted as a result of this.

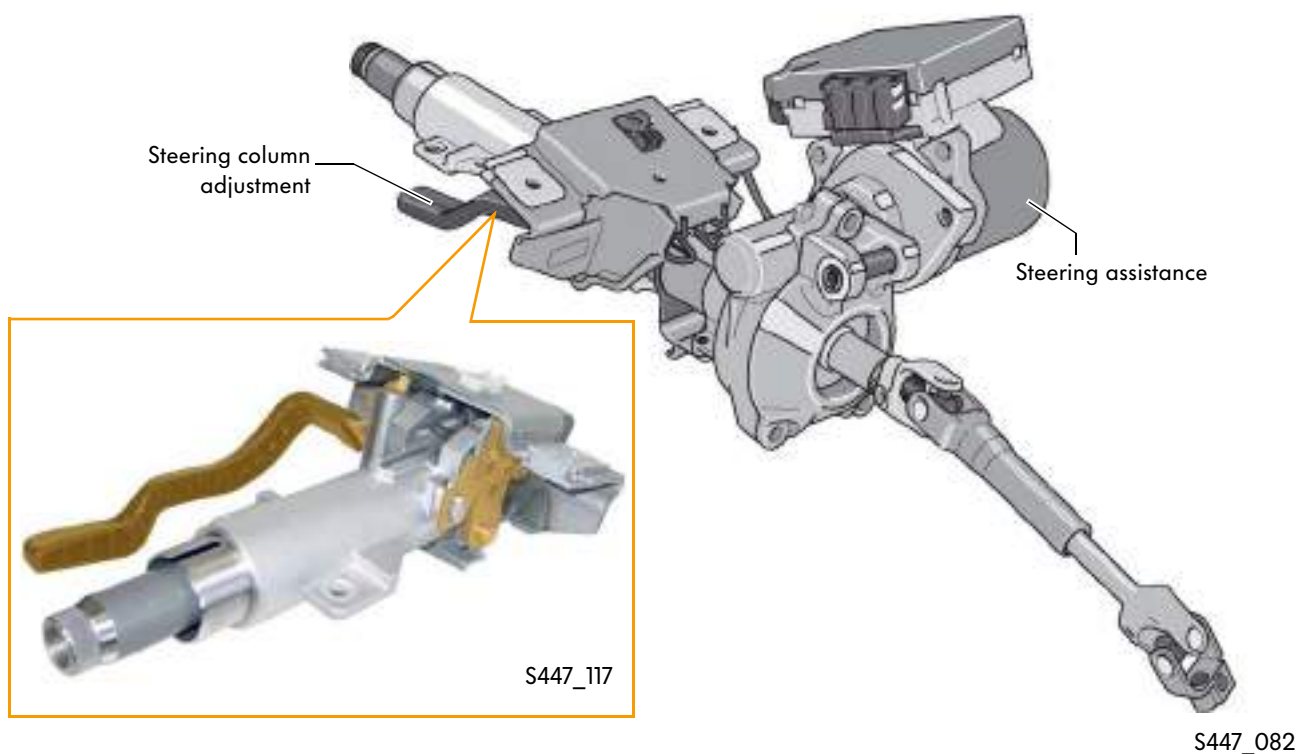

# Running gear

## Worm gear

The worm gear is located in an aluminium housing, to which the electric motor is also secured. A worm gear on the motor's axle engages in the gear wheel on the steering shaft.

The gear wheel body and the worm gear are metal. The gear wheel rim is manufactured from plastic. Mechanical noises are reduced as a result of this.

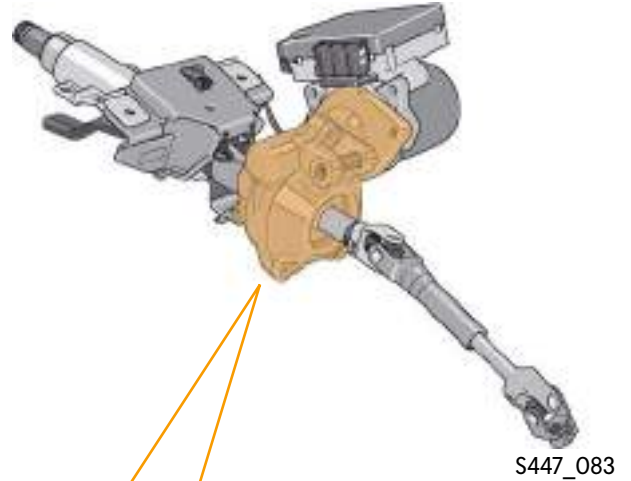

S447\_083

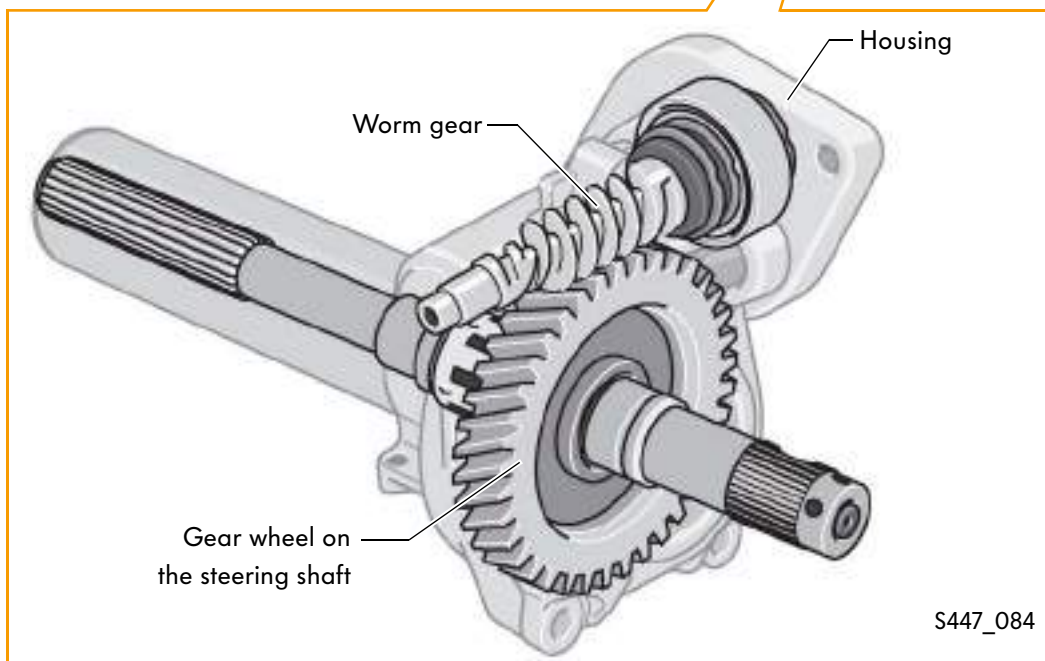

S447\_084

## Steering moment sender G269

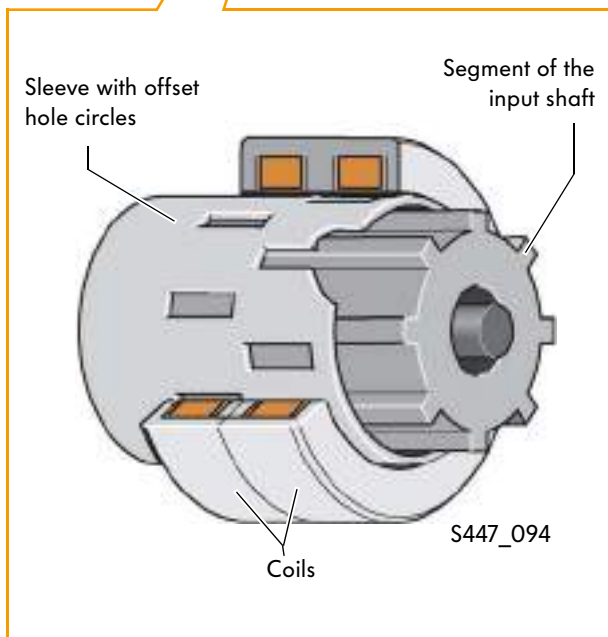
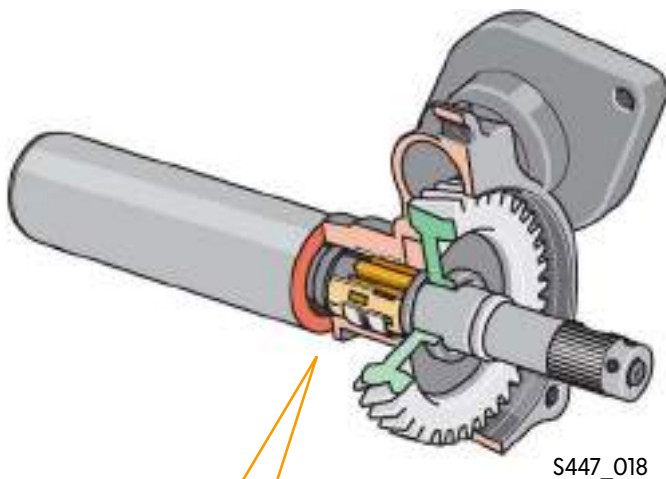

### Effects in the event of failure

In the event of a defective steering moment sender, steering assistance is slowly shut off via the electronics in the power steering control unit J500.

The steering moment applied by the driver at the steering wheel forms the basis for calculating the assistance force provided by the steering system. The steering moment is determined with the aid of the steering moment sender G269. It is mounted on the worm gear axle above the gear wheel.

### Design

The sender consists of an aluminium sleeve (non-magnetic material) with two offset rings of holes. A segmented steel input shaft (magnetic material) moves within this. Two coils are located around the sleeve.

### Function

If the driver turns the steering wheel, the sleeve and the segmented input shaft move relative to each other depending on the moment. In this case, the input shaft's segments influence the alternating current resistance in the coils. This change of resistance leads to a change in voltage, and this is evaluated by the power steering control unit J500.

As the rings of holes are offset, the main signal is generated in one coil and the sub-signal in the other coil.

The main signal controls steering assistance. The sub-signal is required for diagnosis. The sum of both signals results in a constant with a tolerance range. If a constant outside of this tolerance range is calculated, the system concludes that the steering moment sender is defective.



# Running gear

## Electromechanical power steering motor V187

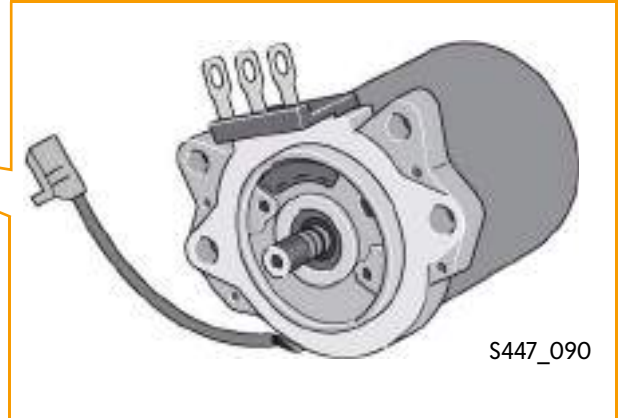
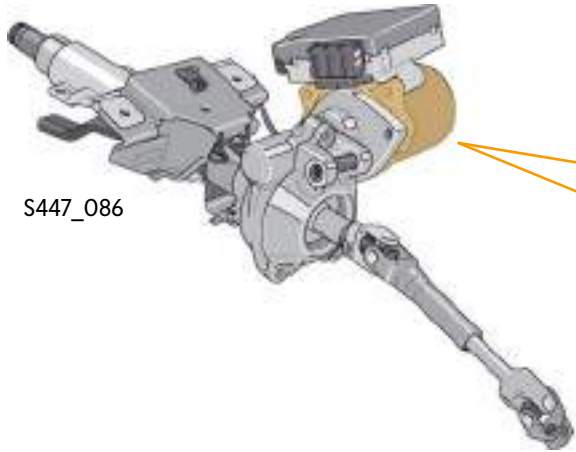

The electromechanical power steering motor V187 is bolted to the worm gear housing. It is a 3-phase synchronous motor and develops a torque of 2.9 Nm to support the steering.

The electromechanical power steering motor is supplied with voltage via the power steering control unit J500.

### Effects in the event of failure

No steering assistance takes place if the motor is defective. This is slowly shut off via the electronics in the control unit.



Further information on a 3-phase synchronous motor can be found in self-study programme No. 399 "The electromechanical steering with parallel-axis drive (APA)".

## Electromechanical power steering warning lamp K161

The electromechanical power steering warning lamp is located in the display unit in the dash panel insert. It is used to display malfunctions and disturbances in the electromechanical power steering.





## Power steering control unit J500

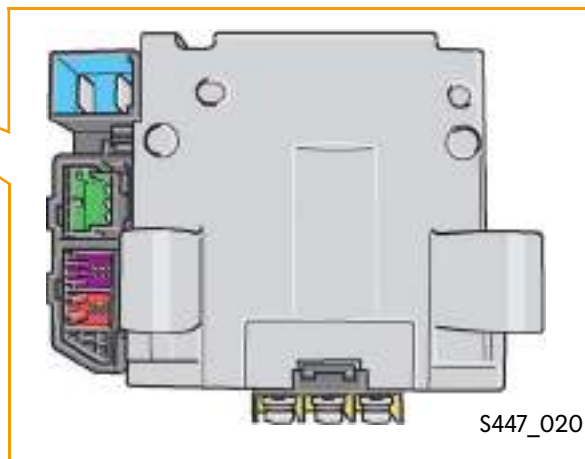
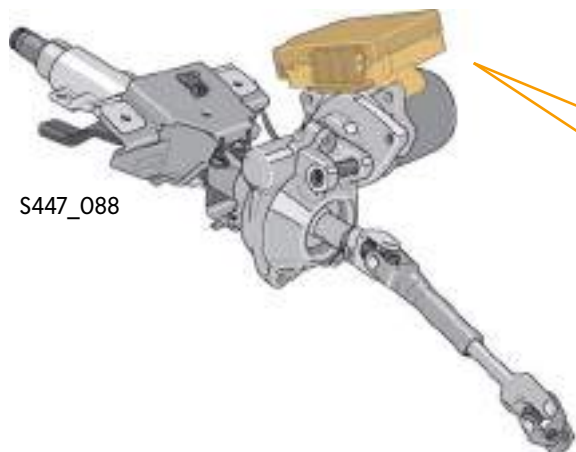





The power steering control unit J500 is secured directly on the electromechanical power steering motor V187, with the result that complex line routing is omitted.

Based on input signals such as:

- The engine speed from the engine speed sender G28,
- The steering moment and the rotor speed plus
- The vehicle speed signal,

the control unit determines the current steering assistance requirement and actuates the electromechanical power steering motor V187.

### Colour code/legend

-  = connection for battery voltage supply terminal 30 and earth terminal 31
-  = connection for CAN low, CAN high and terminal 15
-  = connection for the motor position sender for the electromechanical power steering motor V187
-  = connection for the steering moment sender G269
-  = connection for phase cables for the electro-mechanical power steering motor V187 (3-phase)

### Effects in the event of failure

In the event of control unit failure, no steering assistance takes place and electromechanical power steering warning lamp K161 lights up.



# Heating and Air Conditioning

## Air conditioning

The Polo 2011 is equipped with the same unit as the model year 2002 Polo.

Two variants are fitted:

- The manual air conditioner
- The fully-automatic Climatronic air conditioner.

Both variants have their own operating unit. The manual air conditioner is available with or without chrome trim and the Climatronic with chrome trim.

All temperature- and ventilation-relevant controls and the air conditioner control unit are combined to form one operating unit.

## The manual air conditioner

The Polo 2011 is fitted with a manual air conditioner with an internally controlled air conditioner compressor with magnetic clutch.

The air conditioner is switched on via the air conditioner "AC" button, which is located on the right beneath the four-stage blower switch.

The AC button is locked against the blower switch in stage "0".

The temperature is adjusted using the left-hand rotary temperature selection knob. The adjustment is transmitted to the heater flap mechanism in the air conditioner unit via a flexible shaft.

A potentiometer is additionally installed on the operating unit to electronically detect the set temperature.

The central flap and the footwell and the defroster flap are adjusted via the right-hand rotary air distribution knob by means of a flexible shaft.

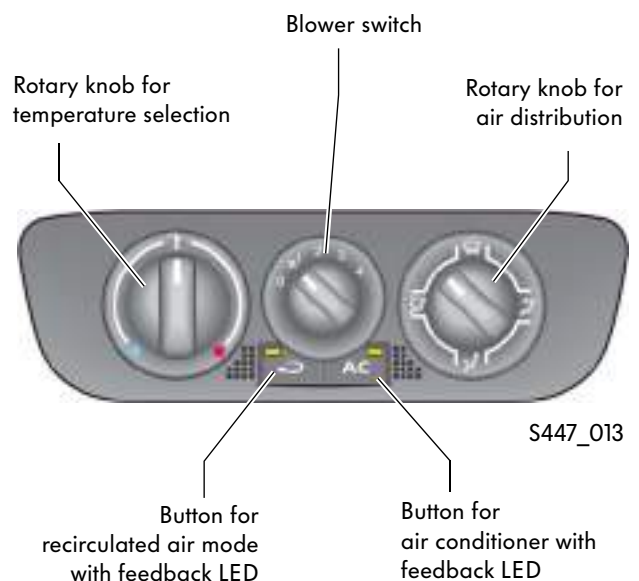

The fresh and recirculated air flap is actuated via the recirculated air mode button. The flap is adjusted via an electric actuator. The "recirculated air" position is indicated by the feedback LED in the button.

## Overview of the system

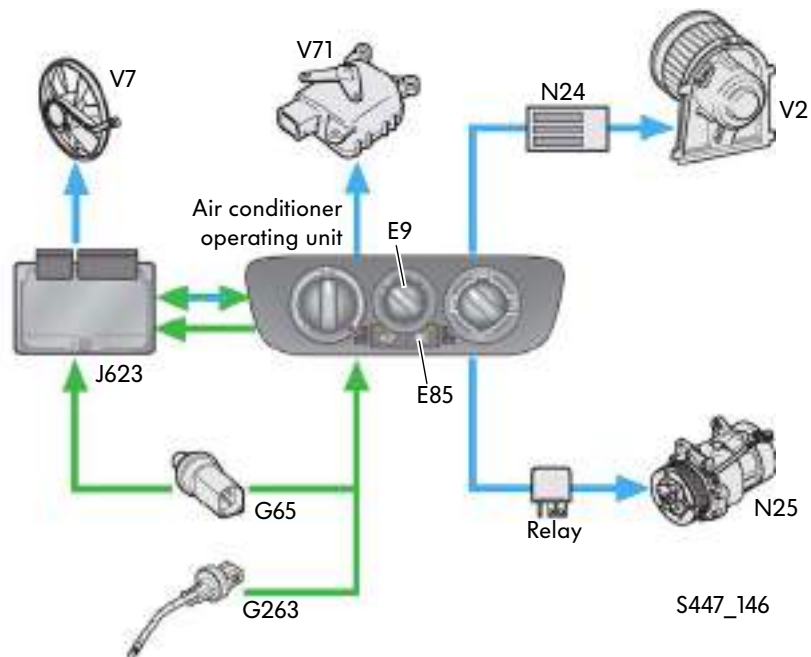

### Legend

E9	Fresh air blower switch	N24	Fresh air blower series resistor with overheating fuse
E85	Air conditioning system and heating button	N25	Air conditioning system magnetic clutch
G65	High-pressure sender	V2	Fresh air blower
G263	Evaporator output temperature sender	V7	Radiator fan
J623	Engine control unit	V71	Air flow flap control motor

The air conditioner operating unit is connected to the engine control unit via a bi-directional cable. When the air conditioner is switched on, the engine control unit receives the signal "air conditioner compressor on". The engine control unit can now prevent the air conditioner from being switched on within 500ms, e.g. if the engine is unable to provide the torque required to operate the air conditioner. When the air conditioner is switched on, the feedback LED in the AC button on the air conditioner operating unit lights up.

Diagnosis of the electrical components is possible via manual measurements using conventional testing equipment. The refrigerant circuit can be tested by measuring the pressures in the high- and low-pressure circuits.



The fully-automatic air conditioner "Climatronic" is described in self-study programme No. 263 "Polo Model Year 2002".



Further information on the air conditioners can be found in self-study programme No. 208 "Air Conditioner in the Motor Vehicle".



# Electrical System

---

## Fuse boxes and relay locations in the vehicle electrical system

### Fitting locations

The vehicle battery is located on the left in the engine compartment. Fuse holders A and C are mounted on the battery negative terminal.

The core element of the control system, the onboard supply control unit, is mounted together with the relay holders on a carrier.



S447\_041





15-fold relay carrier



Fuse holder B



Fuse holder A



Fuse holder C



# Electrical System

## Networking concept

The data bus diagnostic interface J533 (gateway) acts as the communication interface for the following data bus systems:

- Powertrain CAN data bus
- Convenience CAN data bus
- Diagnosis CAN data bus

### Transmission speeds

Powertrain CAN data bus:	500kBit/s
Convenience CAN data bus:	100kBit/s
Diagnosis CAN data bus:	500kBit/s
LIN data buses:	19.2kBit/s

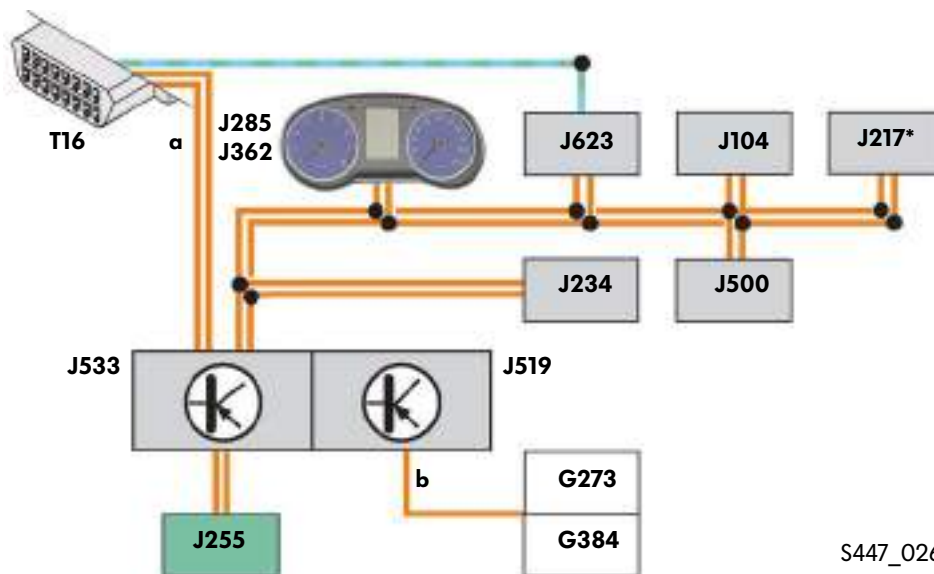

S447\_026



### Legend

- LIN data bus
- CAN data bus line
- LIN data bus line
- K-wire
- Powertrain CAN data bus
- Convenience CAN data bus

- a** Diagnosis CAN data bus
- b** Roof LIN data bus

### Meaning of the codes

- G273 Interior monitoring sensor
- G384 Vehicle inclination sender
- J104 ABS control unit
- J217\* Automatic gearbox control unit
- J234 Airbag control unit
- J255 Climatronic control unit
- J285 Control unit for display in dash panel insert
- J362 Immobiliser control unit (IVC)
- J500 Power steering control unit
- J519 Onboard supply control unit
- J533 Data bus diagnostic interface
- J623 Engine control unit
- T16 Diagnosis connector

\* With automatic gearbox only



## Dash panel insert

The Polo 2011 is fitted with a newly developed dash panel insert based on the new generation of dash panel inserts launched within the Group as of spring 2009. In contrast to the dash panel insert in the Golf, the instrument level is designed as a continuous glass surface. This leads to an increased viewing angle. The dash panel inserts in the Polo 2010 and the Polo 2011 differ in the design of the central display. In the Polo 2011, this has been implemented in a black/red monochromatic design. The central display shows only firmly specified segments. The dial faces in the Polo are always illuminated in white. The number of warning lamps in the round instruments also differs depending on the system.



S447\_048



# Radio and navigation

## Radio RCD 030+

One radio variant is initially available for the Polo 2011.

### Technical features

- Monochrome display 112mm x 30mm
- Display via segments
- FM reception via a single tuner
- AM reception
- 24 memory slots for AM and FM stations each on two memory levels with 6 slots each
- Four output stages with 20 W each
- Two or four speakers can be connected
- Integrated CD drive
- Media support for MP3



S447\_032

### Diagnosis

Diagnosis is possible exclusively via the radio's self-diagnosis function. This is started by pressing station memory buttons 1 and 6. For the automatic test sequence, station memory button 4 subsequently has to be pressed.

### Self-diagnosis options

- Aerial diagnosis: possible displays "OK" or "Fault"
- USB port connection diagnosis: possible displays "OK" or "Fault"
- Radio hardware and software version diagnosis
- Speaker final control test:  
via the relevant selection, various frequencies are actuated in succession on the different speakers and are visualised accordingly on the display. The mechanic decides whether the speaker is OK by means of an acoustic test.

### Combination and expansion possibilities

- Audio input interface (USB)



## The Polo aerial



S447\_034

The Polo 2011 has a rod aerial mounted on the roof for the single tuner's reception.

2 variants of this rod aerial are fitted; externally, they appear identical.

In the active rod aerial, the amplifier electronics are housed in the base of the aerial. This is omitted in the case of the passive version, which is part of the preparation for radio installation.

### Preparation for radio installation/radio with single tuner

Factory fitted preparation for radio installation can be alternatively ordered for the Polo 2011. This contains the power supply cables up to the radio installation position. The speaker cables, which are routed up to the A-pillars, and the aerial cables, which are routed to the hole in the roof, round off the wiring. The passive version of the roof aerial also forms part of this preparation.

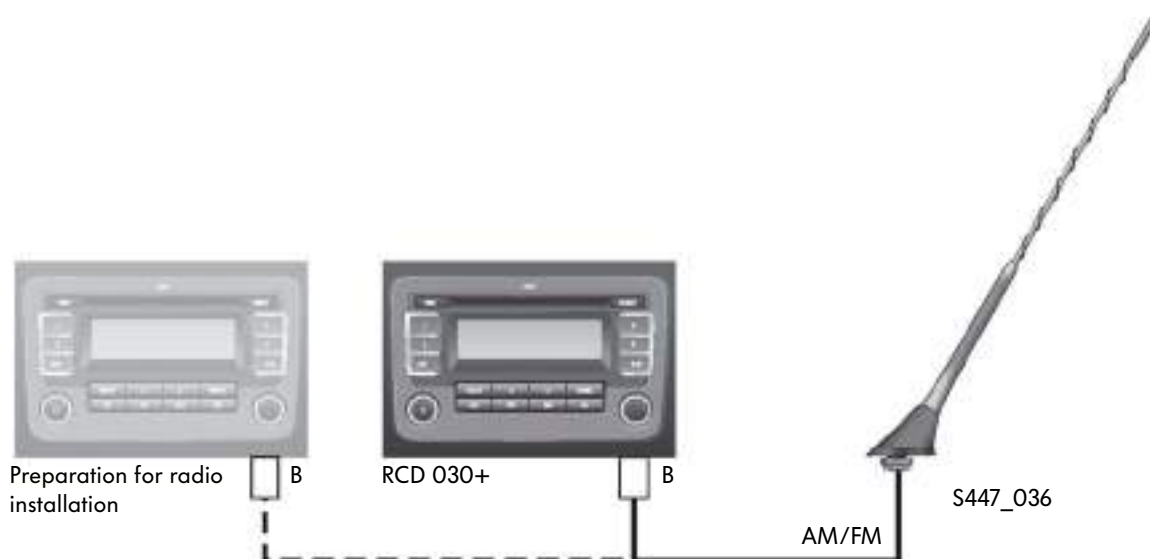

## Onboard supply control unit

Like the onboard supply control unit in the Golf 2009, the onboard supply control unit in the Polo 2011 has been extended with a number of functions. In addition to the functions taken over from the convenience system central control unit J393, the function of the data bus diagnostic interface J533 (gateway) has now also been integrated into the onboard supply control unit J519.

Although a multitude of functions have been combined into one single control unit and housing, the hardware scope has remained approximately the same. The onboard supply control unit is connected via two 73-pin connectors.

Four equipment-dependent variants are currently available:

- Basic
- Medium
- Medium +
- High

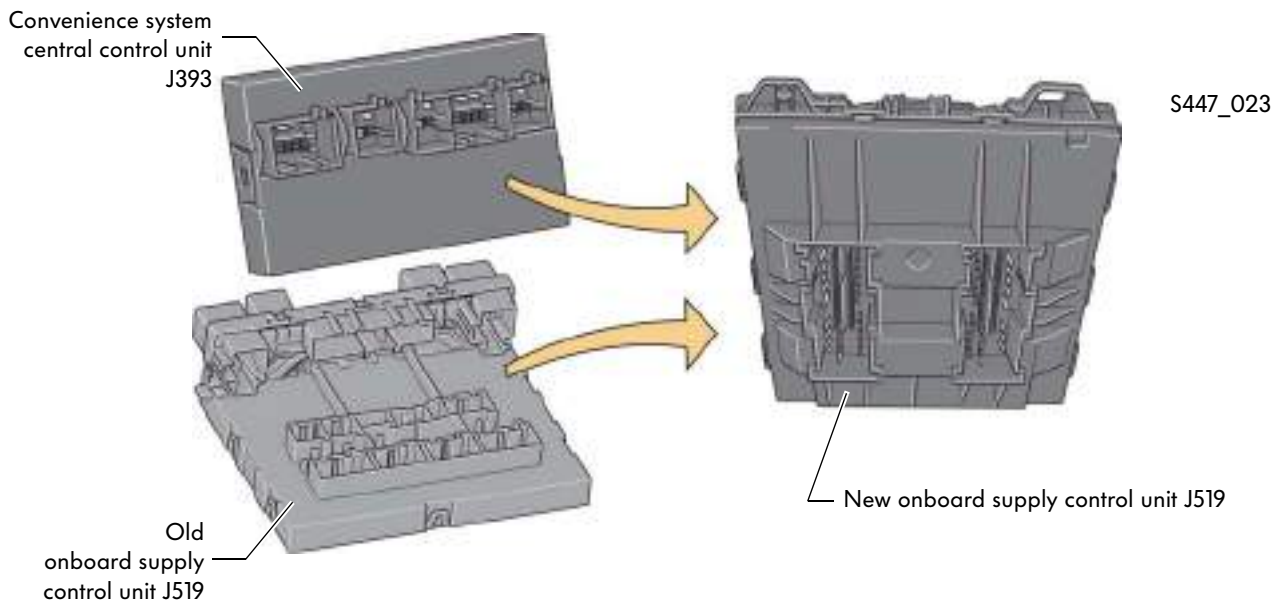

A high number of the lights are actuated by the onboard supply control unit via the integrated semiconductor switches. These include the turn signals, brake lights, hazard warning lights and the tail light (automatic gearbox). One function is actuated via just one control unit output (1 PIN) at a time, e.g. all three left-hand turn signals.

However, the Polo also has lights which are actuated conventionally via load switches, i.e. light switch E1, e.g. dipped beam, main beam and the side lights. The aerial for radio remote control is integrated into the new onboard supply control unit. The radio aerial is not designed as a separate wire aerial, but in the form of a printed circuit board aerial. Reception ranges of 30 - 50 metres are also possible thanks to integration into the onboard supply control unit.

## Installation location

The previous installation location beneath the left-hand dash panel has been retained for the new onboard supply control unit.

Relay carrier on the upper onboard supply control unit

Onboard supply control unit J519

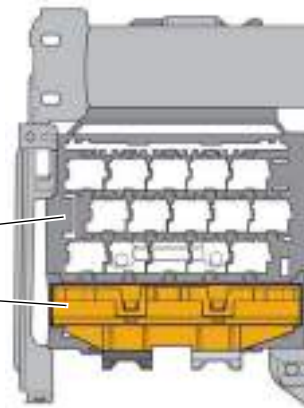

S447\_021

## Functions

The extent of the functions depends on the equipment. In each case, the higher equipment levels are extended by the listed functions.

Equipment	Onboard supply control unit functions
Basic	<ul style="list-style-type: none"> <li>- Terminal control</li> <li>- Load management</li> <li>- Brake light and interior light actuation</li> <li>- Turn signal and hazard warning light actuation</li> <li>- Front wiper actuation</li> <li>- Horn actuation</li> <li>- Door control unit actuation</li> <li>- Tailgate release</li> <li>- Data bus diagnostic interface</li> <li>- Powertrain, convenience and diagnosis CAN</li> <li>- Central locking (lock, door and tailgate actuation)</li> <li>- Door LIN data bus actuation</li> </ul>
Medium	<ul style="list-style-type: none"> <li>- Roof LIN data bus actuation (interior monitor, inclination sensor, rain sensor)</li> <li>- Heated rear window actuation</li> <li>- Actuation of anti-theft alarm with single horn</li> </ul>
Medium +	<ul style="list-style-type: none"> <li>- Radio remote control 433 MHz</li> </ul>
High	<ul style="list-style-type: none"> <li>- Shift lock, starter inhibitor</li> <li>- Reversing light actuation</li> </ul>



## Window lifter switches

In the Polo 2011, the electric window lifter function is implemented via load current switches.

A load current switch means that an actuator is not activated via a control current by means of a relay or control unit, but that the entire current for the actuator to be activated flows through the switch.

The window lifter motor is therefore operated via a switch which has to be continuously actuated. This means that the window is only moved whilst the switch is being actuated. In this case, the operator must make sure that the window's movement path is free.

The Trendline variant of the Polo 2011 is fitted with load current switches in the front doors for the front window lifters.

The Comfortline and Highline variants offer load current switches in all 4 doors.

The driver door is equipped with a double switch which also enables the window lifter on the front passenger side to be operated. The driver side window lifter switch is an auto-down switch. This means that once the second stage has been actuated on the switch, the window moves down automatically.

In the Comfortline and Highline variants, the double switch in the driver door also contains the childproof lock switch.

The rear window lifters can only be operated from the respective local switches.

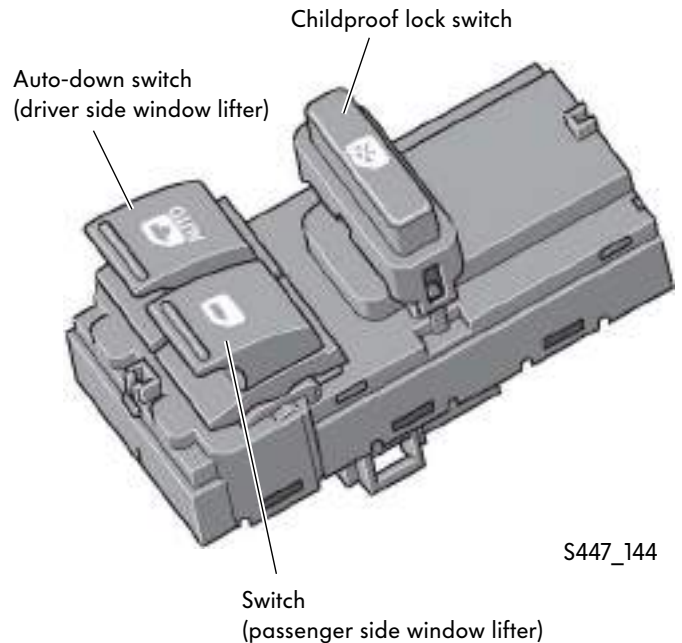

S447\_144

Window lifter switch:

- Blocking current: max. 30A
- Rated current: max. 12A

Childproof lock switch:

- Blocking current: max. 60A
- Rated current: max. 24A





## Locking switch

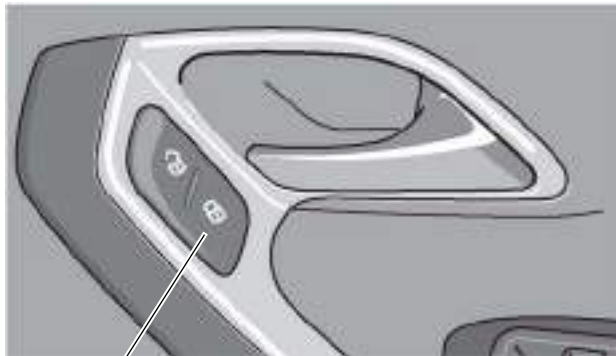

S447\_154

Locking switch

The locking switch (also referred to as the lock/unlock switch) located in the driver door is used to rapidly lock or unlock all doors. It is a control current switch with switch and function illumination, which means that it lights up more brightly during active locking than during normal switch illumination.

Locking switch:

- Blocking current: max. 60A
- Rated current: max. 12 A



# Notes

---



447



© VOLKSWAGEN AG, Wolfsburg  
All rights and rights to make technical alterations reserved.  
000.2812.27.20 Technical status 02.2010

Volkswagen AG  
After Sales Qualifizierung  
Service Training VSQ-1  
Brieffach 1995  
D-38436 Wolfsburg

♻️ This paper was manufactured from pulp bleached without the use of chlorine.