

**THE
81
MARCOS**

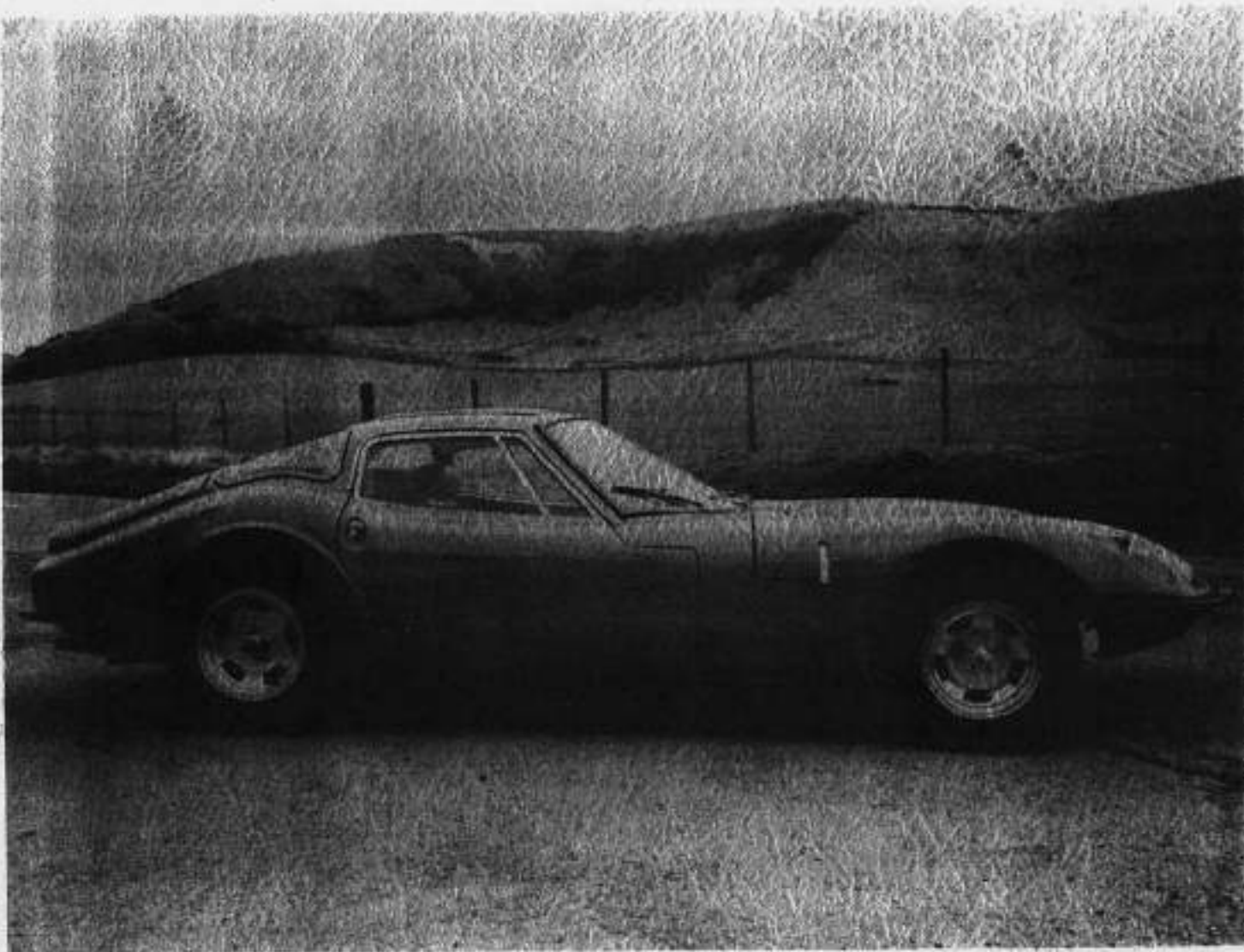

MANUAL

This manual is to assist purchasers of Marcos body chassis units in the completion of their vehicles. We must emphasise that this is only to help you build your vehicle and there are many other parts and ways of fitting the body chassis unit up to road going standards.

Set out below are parts which can be purchased either secondhand, and overhauled, or, in some cases, purchased new through the normal trade channels.

Front suspension from the Vitesse Mark II and all GT 6 models plus other models. This includes the wishbones, uprights, steering arms, brake discs, calipers and hubs. The shock absorber and spring cannot be used.

Rear Axle: Cortina Mark II 1968-70, V4 Capri 1968-72. All these dates are approximate. As long as the nose piece is detachable and the ratio is 3.7:1 or 3.55:1 the axle will be correct. To find the ratio, divide the number of teeth on the pinion into the number of teeth on the crown wheel. The other axle which can be used is the Capri 3 litre, 3.2:1 or 3.01:1. ~~...~~

Steering Column: Triumph Vitesse, Herald or GT6. Preferably the latter type with the three position lighting switch. This must be complete with top mounting brackets and all clamps and fittings, right down to the rack and pinion on the vehicle concerned.

Rack and Pinion: this can be taken off any Herald, Spitfire, GT6. Preferably the latter variety with the mounting brackets; which have a rubber seal between the bracket and the rack. The earlier models had aluminium brackets and are not so desirable.

A hand brake including a gaiter from a Cortina Mark I or II.

Checks to be made on used parts. Obviously, if you are using used, secondhand, parts you must check every item very carefully and ensure that everything is cleaned and oiled, and repacked with grease in the case of the front hubs.

FRONT SUSPENSION. Bottom trunnions are very often worn, due entirely to lack of maintenance. These are shown on a drawing. The calipers should be carefully checked for leaks. New rubber seals for these are easily obtainable if need be. Wishbone Bushes are normally satisfactory but should be checked also discs should not be too badly corroded. The vertical link on the front suspension, in conjunction with the trunnion, should also be checked for any undue wear.

Rack and Pinion. The rack and pinion should be carefully checked for any tight spots. These normally give very little trouble but would be advisable to strip the rack and clean it out and repack it with HMP grease. The ball joints on the end of the rack should be checked and renewed if necessary.

Rear Axle. Occasionally with Ford rear axles, one has wheel bearing failure. This results in oil leaking onto the brake shoes. It is therefore advisable to check your wheel bearings, renew the brake shoes if necessary, and ensure that there are no leaks on the wheel cylinders. In the rear of the manual is a drawing showing the bracket arrangement. These must be attached correctly and by electric welding, not gas, otherwise the axle casing will distort. Should you require these fitted on by our Marcos works we can do this for you - P.O.A. The brake pipes on the axle must be checked for corrosion. Also ensure that the handbrake compensator is working freely.

The rear halfshaft flange and brake drum have different wheel centres to the front hub. To ensure that all the wheels have the same centres, it is necessary to have the halfshaft and brake drum redrilled and the back of the half-shaft machined. This is a simple operation and must be done exactly to the drawing in the back of the manual.

ASSEMBLY INSTRUCTIONS

The front suspension fits straight onto the Marcos frame using the nuts and bolts as listed in our nut and bolt sheet in the rear of the catalogue. The spring and damper should be fitted with the adjusting screw at the bottom, using the correct bolts.

The rack and pinion steering should be bolted on the chassis using the standard Triumph brackets and rubbers.

The rear axle should be fitted with the 4 radius rods. The adjustable radius rod to be fitted last and adjusted to suit the correct length between the axle bracket and chassis. The Panhard rod can then be fitted. Fit it to the chassis first and then onto the axle. The Panhard rod must be adjusted to ensure that the back plates of the axle, on both sides, are the same distance away from the main chassis tubes. The spring damper units are fitted with the adjusting screws on the bottom.

Ensure that the lock nuts on the adjustable radius rod and Panhard rod are done up really tight.

Having fitted the front and rear suspension and modified the halfshafts, you can now fit your wheels.

Fit master cylinders, these are girlings $\frac{3}{4}$ " bore with an adjustable rod and vertical reservoirs, to pedal carriage. Fit flexible hoses to suit onto cylinders and to steel pipes, via a suitable bracket in order to support them, see drawing. The brakes can now be bled. It is best to bleed them once and leave them overnight, and then you can bleed them again to ensure there is no air in the system.

Having already obtained your handbrake, cut a hole in the floor to accept the moving part of the brake and bolt on the cable support bracket underneath (see drawing). Fit the Marcos handbrake cable to the moving part of the handbrake, using the cable and clevis pin supplied. The other end of the cable fits to the compensating mechanism of the rear axle.

It is very often better to hear the engine you have chosen running before you buy it. If possible, drive the car to ensure that it has good oil pressure and does not smoke from the oil filler cap. Thoroughly check and clean all ancillaries to minimise any failure at future dates.

The engine can be fitted to the Marcos with the ancillaries fitted with the exception of the exhaust manifolds which should be left off (see nut and bolts list for size of bolts etc.)

Exhaust manifolds V6 engine. These are reversed. Left on righthand side and right on lefthand side. The 1600 manifold is a special Marcos one; likewise the 1500 Ford engine, 2.5 litre Triumph and 3.0 litre Volvo engines, utilise the standard exhaust manifold. The exhaust system is peculiar to the Marcos and a correct one must be used.

Fuel Pipe. Connect fuel line to pump using a suitable 3" length of flexible pipe, ensuring there is no leakage. Connect other end of fuel pipe to tank.

To connect up the wiring of the car thoroughly study the wiring diagram. Take great care with all connections, nothing is more frustrating than an unreliable wiring system.

Mount ignition coil in a suitable place on the chassis as near to the distributor as possible, and connect.

Fit a suitable clutch flexible pipe to slave cylinder and connect to steel pipe to run from flexible to pedal carriage. The loose end of the slave cylinder flexible is clamped to the chassis via the bracket fitted to the chassis.

Radiator. To obviate the cost of a new radiator, the Austin 1800 radiator can be used, suitably modified (see drawing in the rear of manual). It is recommended that an electric fan is used rather than the existing one on the engine. For the V6 an electric fan is advisable.

Numerous fans are suitable for this: Fiat, Renault or a new Kenlow. Convoluted hose can be used for the water system but special hoses are obtainable from Marcos.

Prop Shafts. A suitable prop shaft must be used according to which axle and engine you have fitted. These can be made up yourself by using the parts off secondhand prop shafts but we do offer these to the builder.

Gear Levers. The gear lever on the 3.0 litre gear box requires bending to suit the driver (see drawing in rear of manual). The 1500 Ford, 1600 Ford, 2.0 litre Ford engine, Volvo 3.0 litre and 2.5 Triumph can remain standard.

The Steering Column. The brackets on the top end of the Triumph concerned can be used and bolted onto one of the three positions on the dash board to suit the driver. An angle bracket is needed to carry out this operation (see drawings). The bottom fitting of the special Marcos universal joint must be fitted carefully ensuring that the angles are not too sharp, thus making the steering tight. It is essential that the 2 pinch bolts holding the Marcos universal joint assembly to the rack and pinion are fitted so that they go through the grooves in the pinion and Marcos special assembly correctly.

Fuel Tank to fit this - use special bracket (see drawing in the rear of the manual).

We recommend fitting, then removing the door and frames before painting the car, to minimise damage to the paintwork. Fit the quarterlight and drop glass rubbers into the frame. Fit quarterlight into rubbers and secure with small bracket, shown in drawing list. Fit the window regulator channel onto the drop glass, using an old inner tube between the two, ensuring the steady bracket does not touch the frame when fitted. Slide the drop glass complete with channel into frame and tape into position to facilitate fitting. Fit the frame complete with glasses into the door shell. Trim the door to ensure that the frame fits into the aperture with an even gap all the way round. Drill and fix the front edge of the frame to the door (see bolt list). Drill and fix frame to back edge of door. Close the door and adjust the frame top edge either in or out, by moving the bottom of the frame. When an even gap is obtained, secure the bottom of the frame to the door. The frames should now be removed and the doors painted. Refit the frames as detailed above and proceed. Fit the window motor and regulator, ensuring that the wires are on the motor as these are fairly inaccessible with the motor fitted. Connect all the wiring for the window motors. Move the drop glass into the full up position and mark the regulator gear tooth nearest the gear wheel. Repeat the procedure with the glass in the down position. Fill the gap between the relevant teeth with weld as shown in drawing.

Fit the door lock as shown in the drawing list. Fit locks and striker plates using bolts listed. These are Morris 1300, 2-door, 1969/MGB 1972. Use control rods modified from the same vehicle and the interior handle.

Fit the outer door push button and fix bracket as in drawing list. MGB boot lid/Morris 1300 boot lid.

BOOT LID

Fit boot hinges to boot lid. Fit hinge brackets to rear bulkhead. Attach the hinges to the brackets and adjust to fit. In some cases it may be necessary to bend the hinges to suit. Fit the boot stay to the offside hinge and to the boot undertray, see drawing.

Fit boot push button to back panel. Fit the interior lock assembly to back panel and the bracket to the boot lid. Adjust to suit.

To fit rear screen, cut 4-3" lengths of rear screen rubber supplied and fit onto aperture, 2 forward and 2 rear. Fit the screen into the rear rubbers and mark around the aperture, then grind the screen down to size using a grinding disc on a drill. Periodically check the screen in the aperture until there is an even gap all the way round. Then fit the complete rubber into the aperture. Fit the back of the screen first, then the front edge, leaving the sides until last. When fitted, fit the filler strip. The tool used for this is called a "Clayton Wright" filler strip tool.

Ensure that any apertures between the engine compartment and cabin are effectively sealed. This is as much for noise as it is to prevent the intrusion of fumes. Before fitting any upholstery, fit ½" sound deadening felt everywhere except the arm rest adjacent to the door shut. Felt glued to the inner face of the door skim will considerably reduce noise.

The best advice that can be given regarding interior trim is to study a good original example of the marque and follow it closely. Otherwise we do provide an expert trimming service and we are able to supply individual panels including carpet sets. P.O.A.

If you are using the Headlamps supplied in stage III, then you must use a combined side indicator lamp. These can be obtained through your British Leyland dealer as used on Morris Minor, Austin, A40 and A60.

A rain gutter should be fitted to the front, top and back edge of the door aperture, this is a 'J' section made from aluminium and can be obtained through any coach/body builder. Do not attempt to fit this in one piece, but cut and mitre a joint at the top front edge of the aperture. Pop rivet the guttering to the body.

Wheels and Tyres. Previous production cars were fitted with either 175 x 13 or 185-70 x 13 tyres on 5½" rims, we do not recommend any wider than 6" wheels.

After the headlining has been fitted the interior mirror can be installed. If you use a screw fitted mirror you must feel for the wooden block bonded into the roof panel approx. ½" to 1" back from the screen aperture, ensure that the screws used are not too long and penetrate the roof panel.

When the inner mudguards have been fitted and prior to painting, the lower scuttle should be lined up to match the line of the bonnet. To do this close the bonnet and close the side catch. Using a suitable piece of wood, prop the lower scuttle panel (this is the f/glass part of the body directly beneath the bonnet side catch), until it is directly in line with the bonnet side panel. using f/glass matting and resin (obtained through most paint and body factors). Laminate the inner mudguard to the inside of the lower scuttle panel and leave overnight to cure properly.

Screen Wipers. The wiper motor is a Lucas 14 W model with a sweep of 120°, the wheel boxes too are again Lucas part number 72879, the drive rack is a standard item (Lucas). The wiper tubes to use are made up with the ends flared to the following lengths 20", 10½" with nut 2½".

Should you have any difficulty in obtaining these items we can supply a complete wiper kit P.O.A.

We strongly advise using a bonnet lock for security and safety reasons.

The glove locker can be made up to your own requirements from 'Pressboard', obtainable through any good coach trimmer.

Paintwork. Fibre glass cars are painted in exactly the same way as steel ones, but ensure that at least two good coats of f/glass sealer are applied before any other paint. The sealer should under no circumstances be rubbed down before priming as this breaks the seal, as its name implies, and could cause problems when applying the colour. We have found through experience that the car is best painted without any body parts fitted, i.e. door frames, locks, screens, badges etc., as this ensures that there are no unsightly marks and lines when the masking tape has been removed.

Radio Suppression. It must be pointed out that cheaper radios are always difficult to suppress. The aerial must be at the back of the car and not on the roof by the engine compartment. A large I.M.C.F. suppressor should be fitted to the coil and this must be the feed through type, so that the current feeding the coil runs through it. A smaller one should be fitted to the Dynamo/Alternator. In some cases it may be necessary to put one on the feed wire to the wiper motor as well.

Ordinary cooking foil should be glued to the underside of the bonnet but need not extend over the mudguard area. This should then be earthed to the chassis via any of the black wires in the loom by the head side lamps.

If you still have interference, it may be necessary to completely shield the plugs by some form of metal screening.

Should you have any difficulty obtaining parts we can supply most items ex stock P.O.A.

It is clearly understood that Jem Marsh Performance Cars cannot be held responsible for any purchasers of body chassis units who fit parts which we do not recommend.

NUT AND BOLT LIST

FRONT SUSPENSION	
Wishbone to chassis (top and bottom)	2 1/2" x 3/8" unf.
Shock Absorber top and bottom	2 1/2" x 7/16" unf.
REAR AXLE	
Radius Rod to chassis and to axle	2 1/2" x 1/2" unf.
Shock Absorber top mounting	2 1/2" x 7/16" unf.
PROPSHAFT using Capri 3L axle	
Adaptor plate to axle	M10 x 1
Propshaft to adaptor	3/4" x 3/8" unf.
PROPSHAFT using Cortina, Corsair	
Prop to gearbox flange (2.5 x Volvo)	1" x 3/8" unf. 1 1/2" x 3/8"
ENGINE MOUNTS	
V6 Ford mounting rubber to chassis	1" x 5/16" unf.
2.5 mounting rubber to chassis	1" x 3/8" unf.
1600 - 1500 mounting rubber to chassis	1" x 3/8" unf.
Volvo mounting rubber to chassis	1" unc. unf.
V6 mounting plate to engine	1" x 3/8" unf.
1600 - 1500 mounting plate to engine	3/4" x 5/16" unf.
Volvo mounting plate to engine	3/4" x 5/16" unf.
GEARBOX MOUNT	
Crossmember to chassis all models except Volvo	1" x 5/16" unf.
Crossmember to chassis Volvo	3/4" x 1/2" unf.
V6 gearbox mount to crossmember	1" x 5/16" unf.
2.5 gearbox mount to crossmember	7/16" unf. nut.
V6 mount to gearbox	1" x 1/2" unf.
2.5 gearbox mount to gearbox	1 1/2" x 1/2" unf.
1600 - 1500 gearbox mount to gearbox	1" x 3/4" unc.
Volvo gearbox mount to gearbox	7/16" unc. nut.
Handbrake levers to brackets	1 1/2" x 5/16" unf.
Handbrake compensator pad to axle bracket	3/4" x 1/2" unf.
Steering Column top bracket to inner Dash Wood	1 1/2" x 3/4" unf.
DOORS	
Door hinge to body	1" x 5/16" unf.
Door hinge to door	1" x 5/16" unf.
Door frame to door top and bottom	1" x 2 ba.
Door lock to door	1 1/2" x 1/2" unf. csk screws
Door lock catch plate to body	1 1/2" x 1/2" unf. csk screws
Window regulator to frame	3/4" x 1/2" unf.
Door frame to door back edge	self tapping screws and spire nuts
BOOT	
Boot hinge brackets to body	1" x 2ba.
Boot hinge to body brackets	1" x 1/2" unf.
Boot hinge to boot lid	1" x 2 ba.
Boot lock mech upper to lid	3/4" x 2 ba. into rawnuts
Boot lock mech to body	3/4" csk 2 ba. screws
Boot stay to hinge o/s	1" x 1/2" unf.
Boot stay to body	1" x 1/2" unf.
Fuel tank securing bracket to body	1" x 1/2" unf.
Mudguards secured by self tapping screws	

COLOUR CODE

B	=	BLACK
G	=	GREEN
N	=	BROWN
P	=	PURPLE
R	=	RED
U	=	BLUE
W	=	WHITE
Y	=	YELLOW
LG	=	LIGHT GREEN
S	=	SLATE/GREY

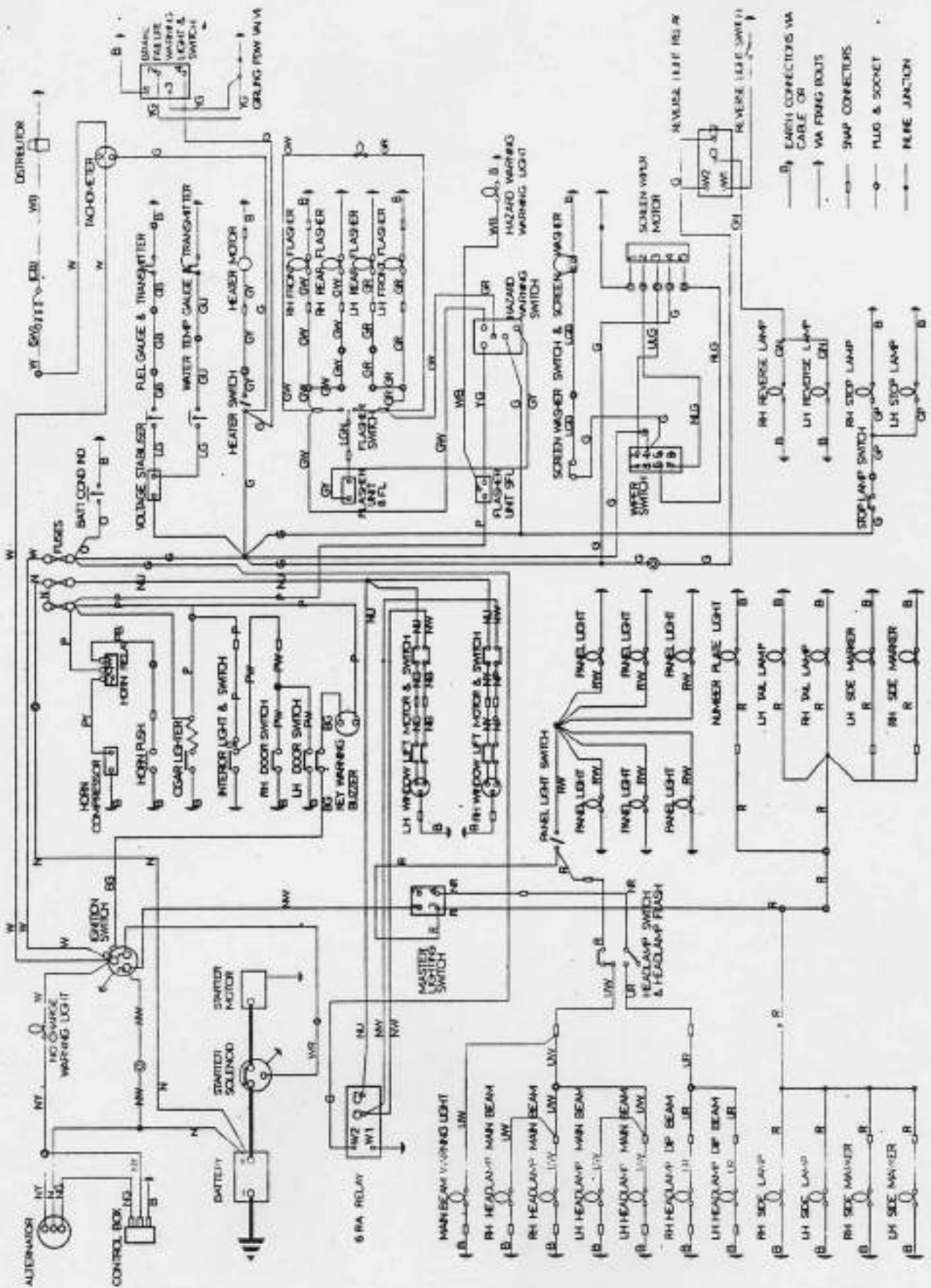

VOLVO 3 LITRE MANUAL

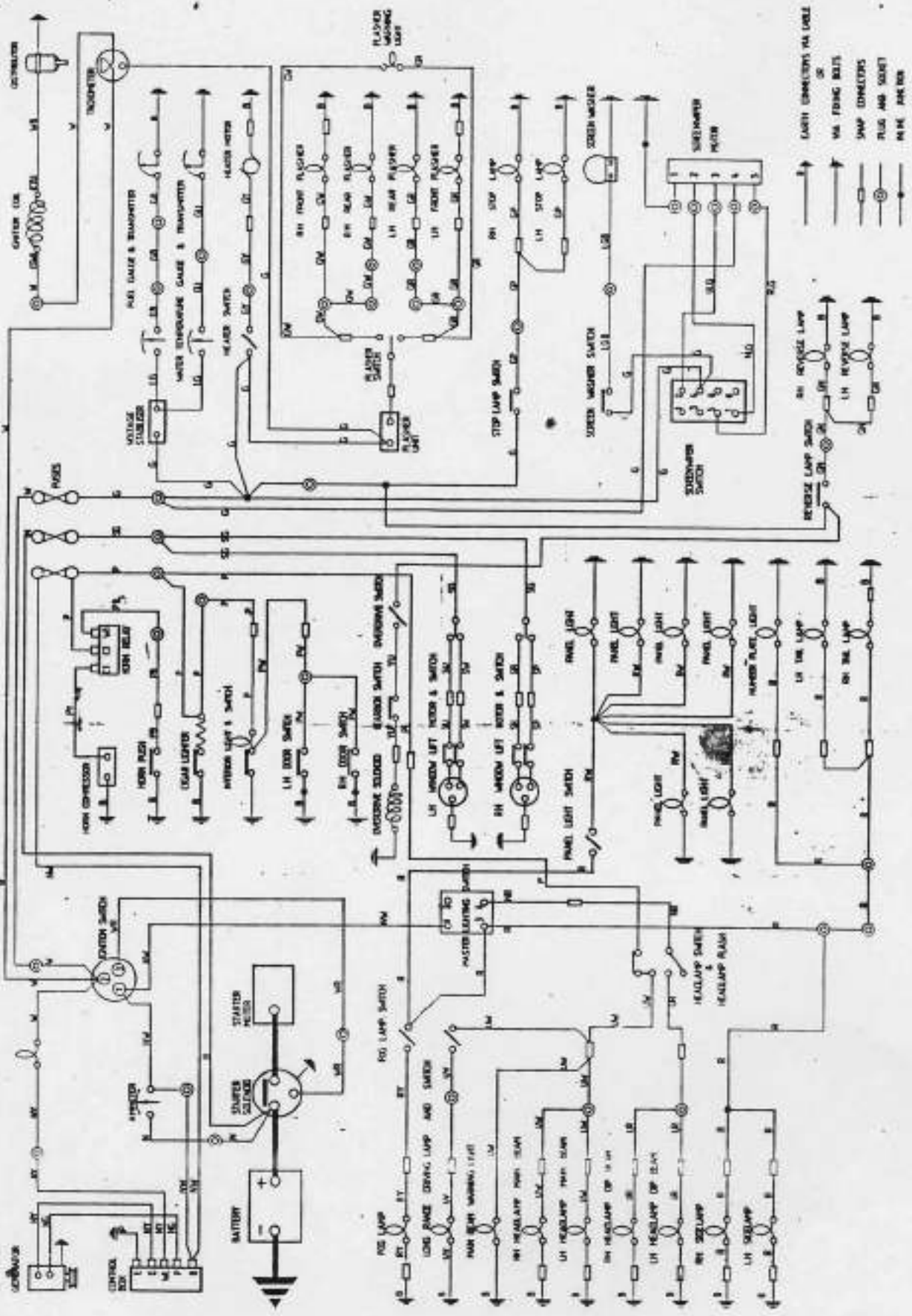

FORD V-6 WITH OVERDRIVE

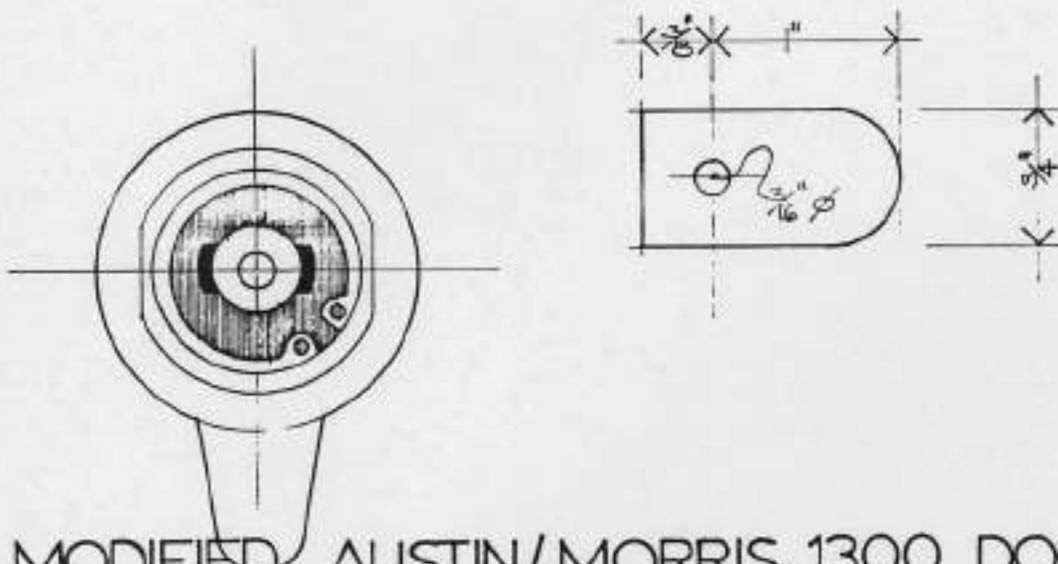
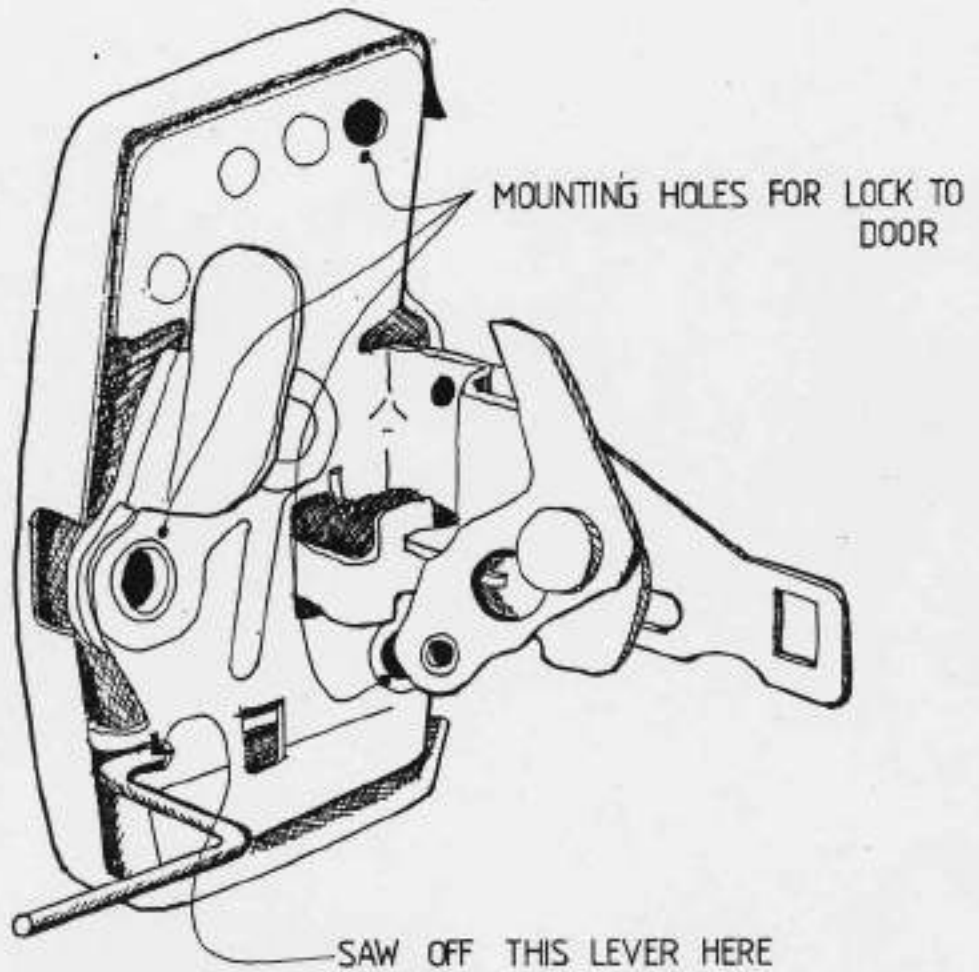

MODIFIED AUSTIN/MORRIS 1300 DOOR LOCK

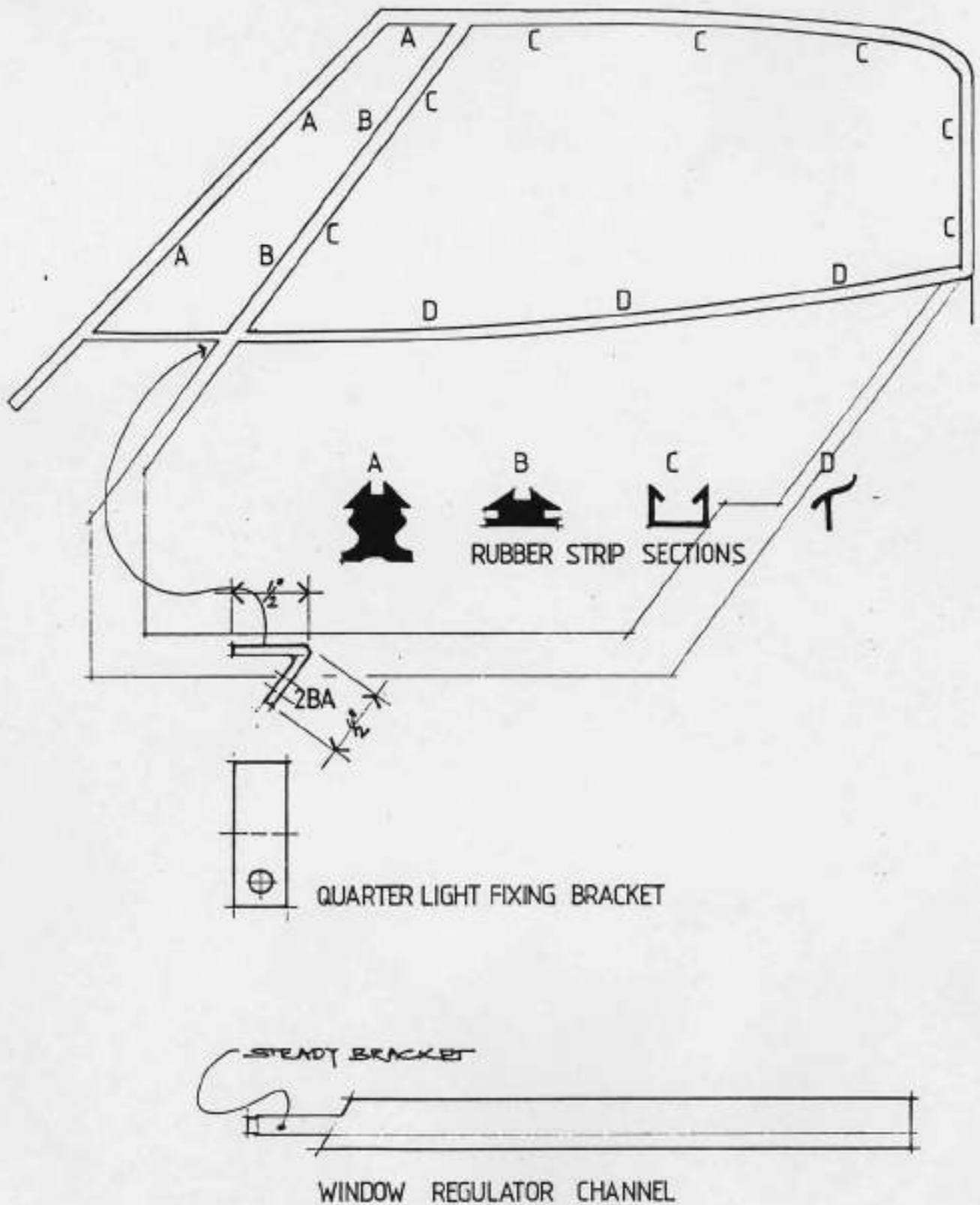

WINDOW FRAME

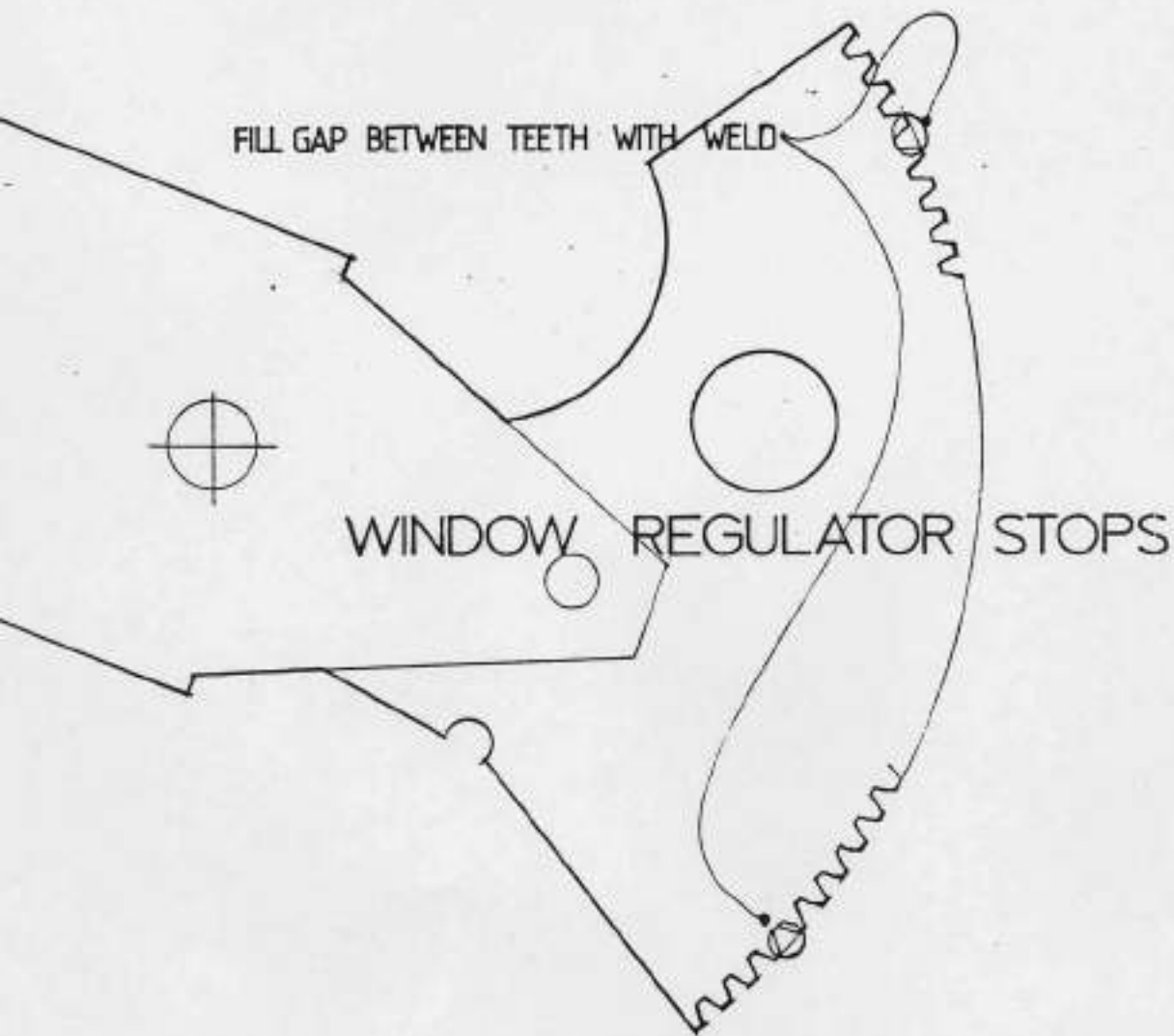
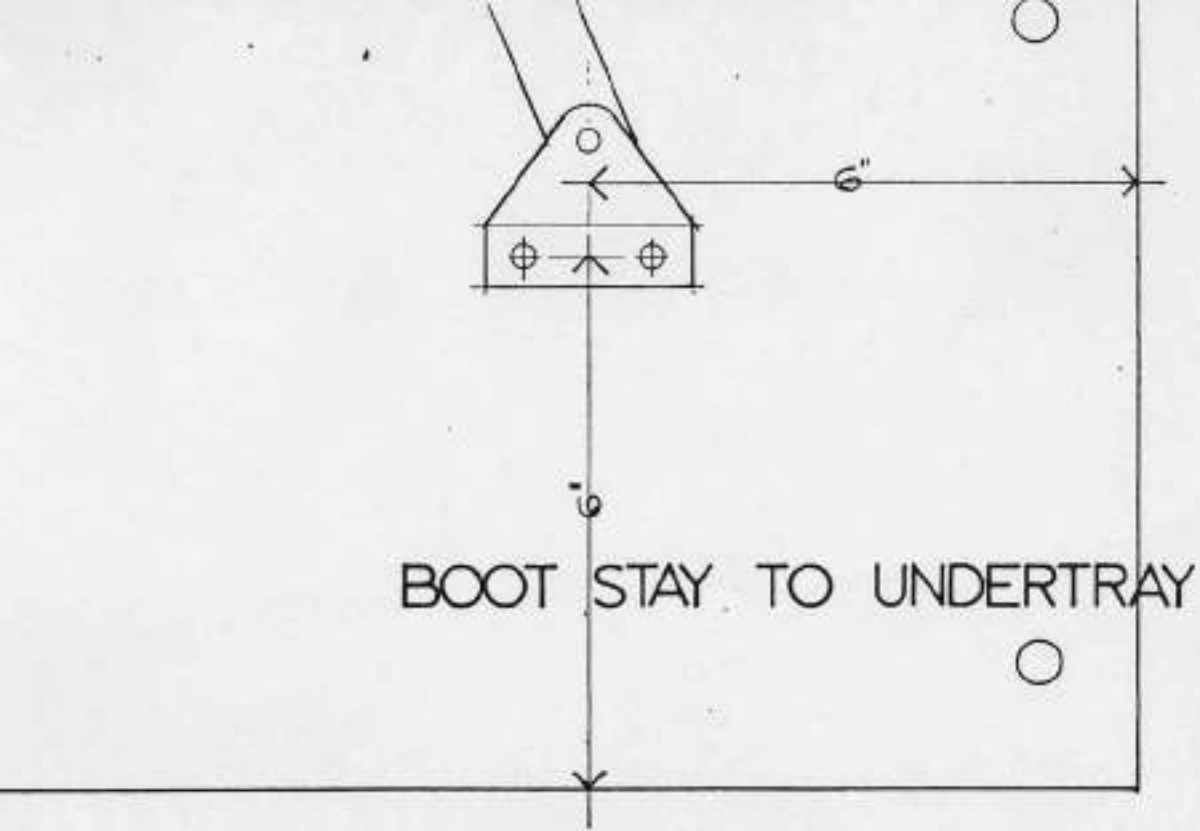

LOCATION HOLE FOR PANHARD ROD

DOOR LOCK LATCH PLATE SUPPORT

FIVE WAY HYDRAULIC COUPLING & SWITCH

GEARBOX MOUNTING

ENGINE MOUNT POSITION

RACK MOUNTING

BOLT HOLES FOR BONNET HINGES

BOLT HOLES FOR LOCATION OF RADIUS RODS FOR AXLE

SPRING/DAMPER MOUNTING

SEAT BELT FIXINGS

HANDBRAKE BRACKETS

PEDAL CARRIAGE BRACKETS

LOCATION OF TOP ROSE JOINT FOR STEERING COLUMN

SPRING/DAMPER MOUNTING

UPPER WISHBONE BRACKETS

LOWER WISHBONE BRACKETS

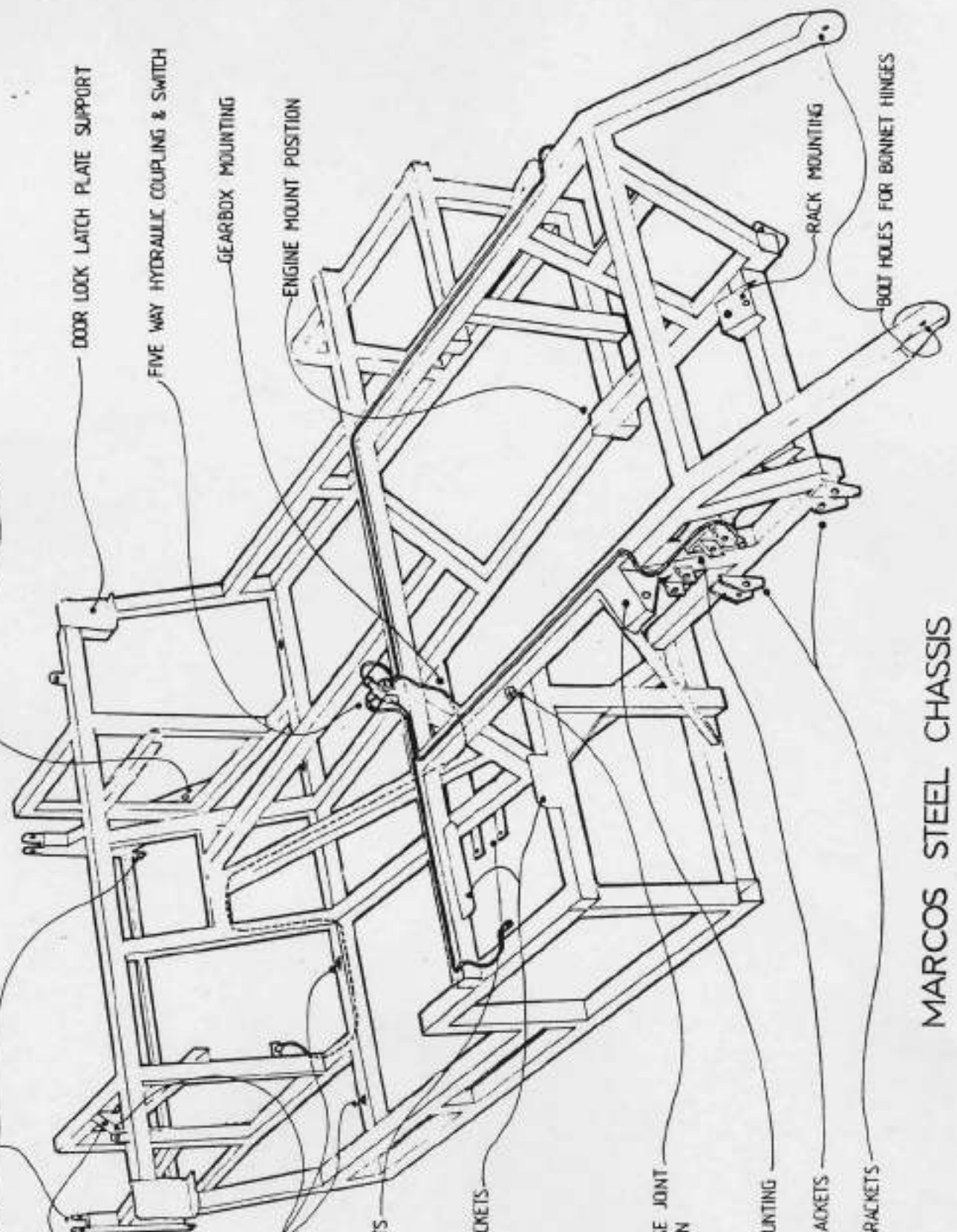

MARCOS STEEL CHASSIS

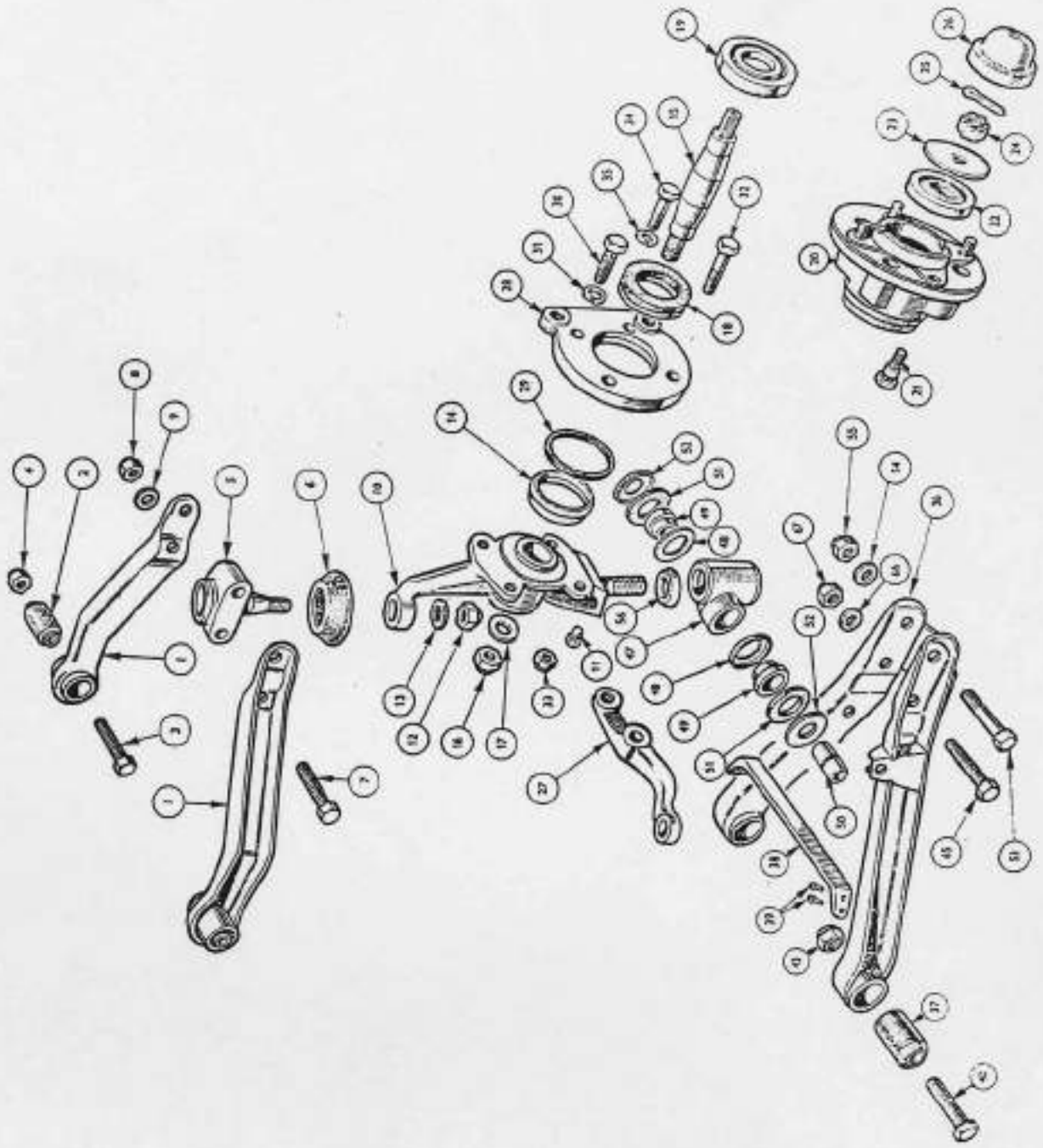

TRIUMPH VITESSE MK 2 FRONT SUSPENSION

E-TYPE RAD.

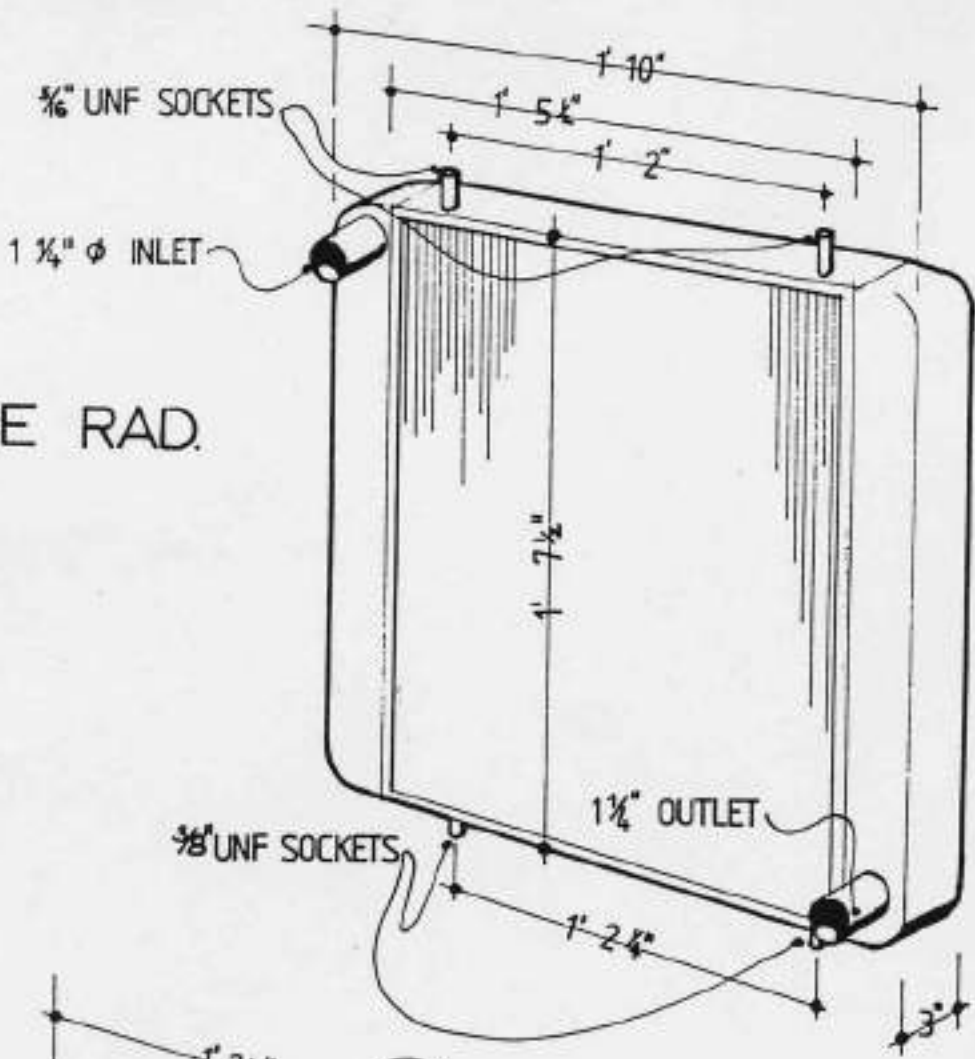

TRANSIT INLET 1 3/8" ϕ

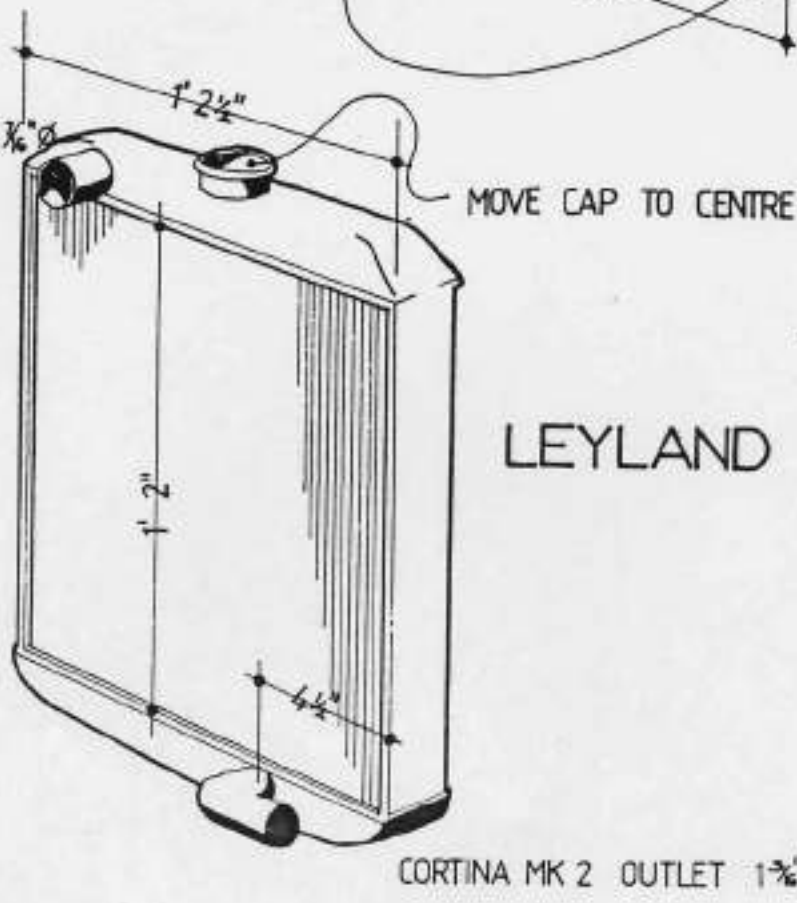

LEYLAND 1800 RAD.

CORTINA MK 2 OUTLET 1 3/8" ϕ

FUEL TANK BRACKET

14 G STEEL

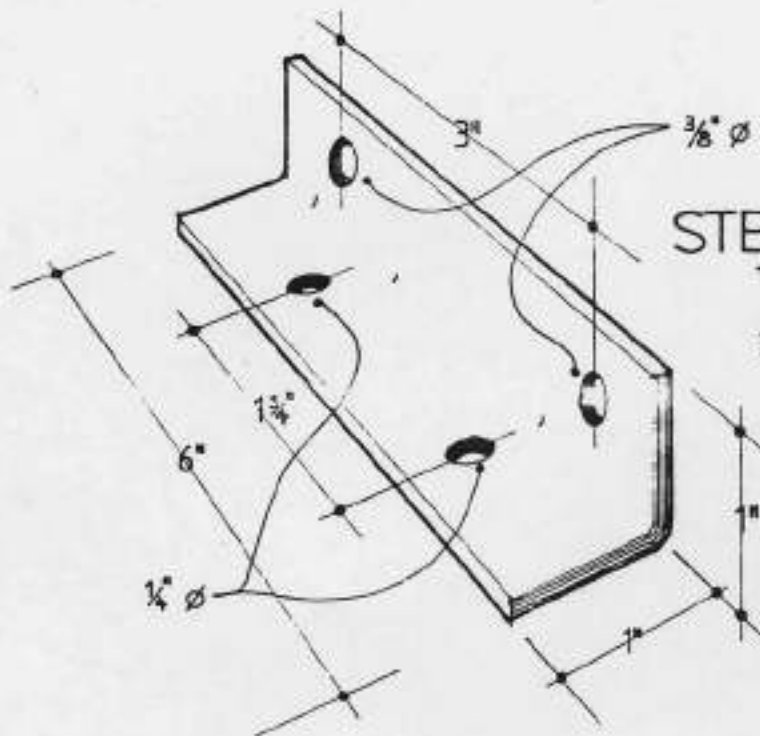
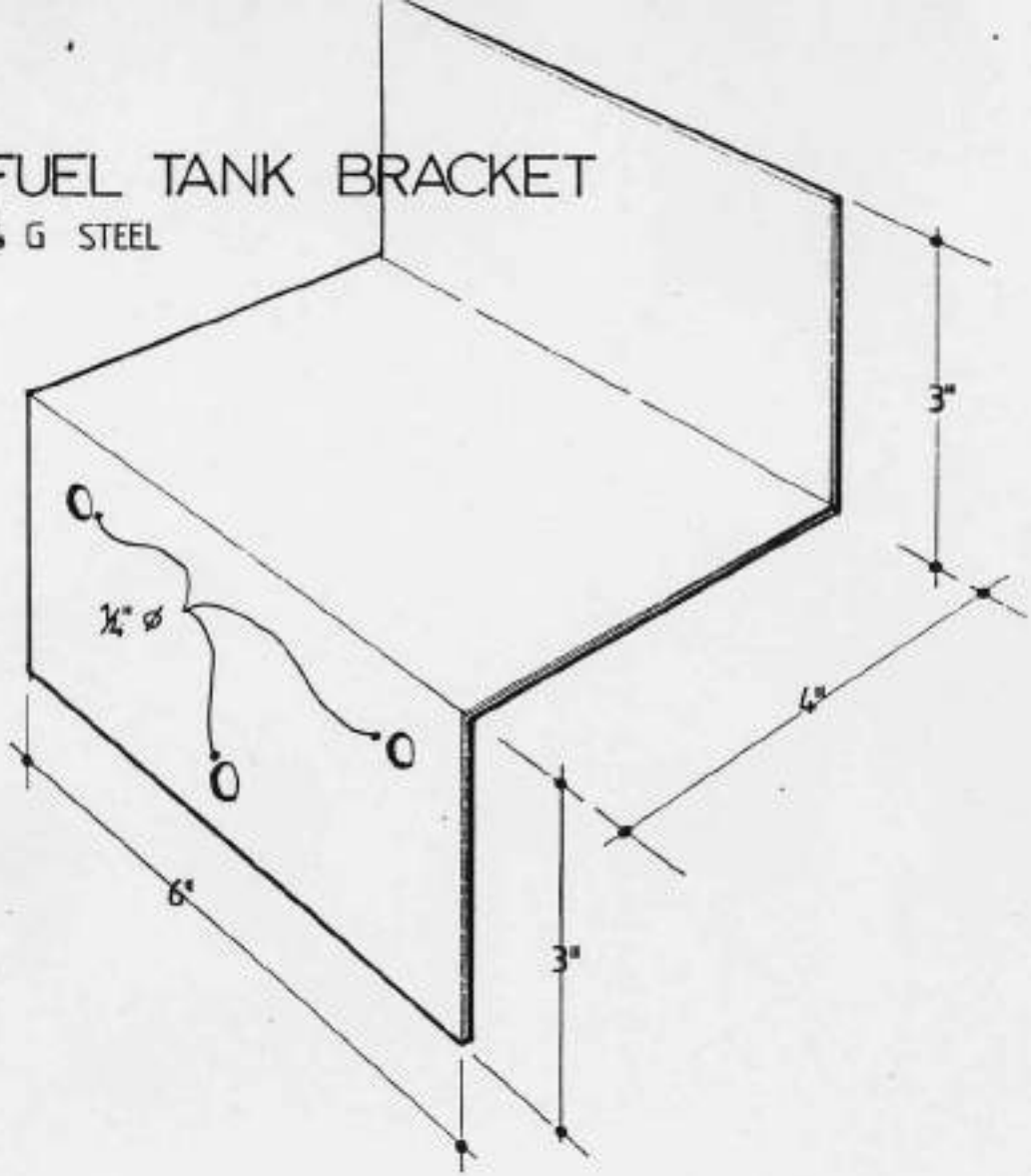

STEERING COLUMN TOP BRACKET

3/8" MILD STEEL

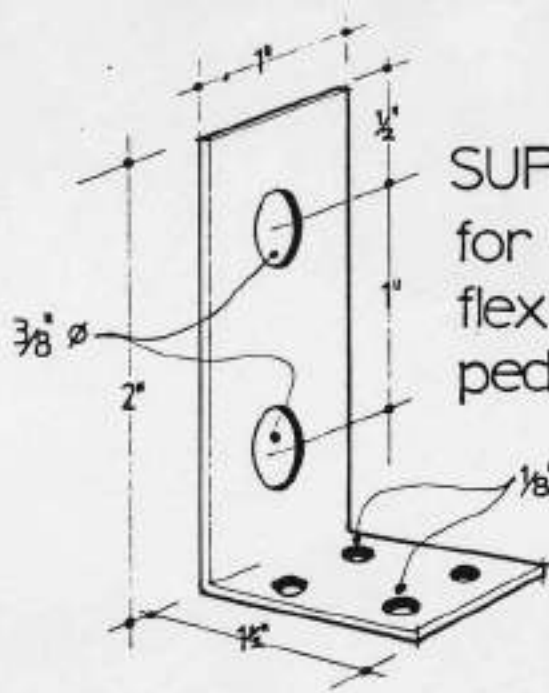

SUPPORT BRACKET
for clutch and brake
flexible pipes from
pedal carriage

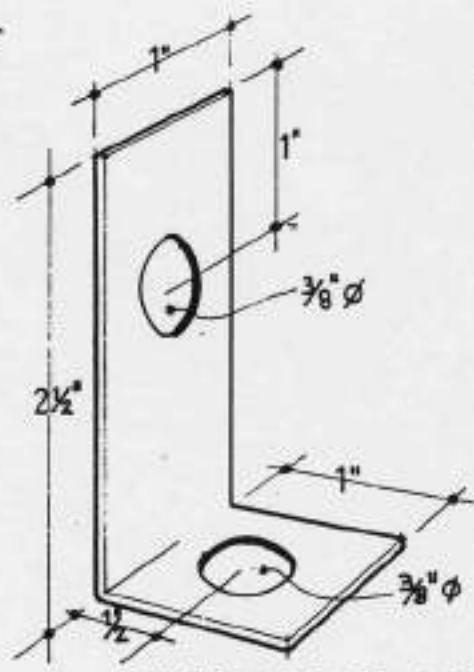

SUPPORT BRACKET
front flexible brake
pipe to wishbone

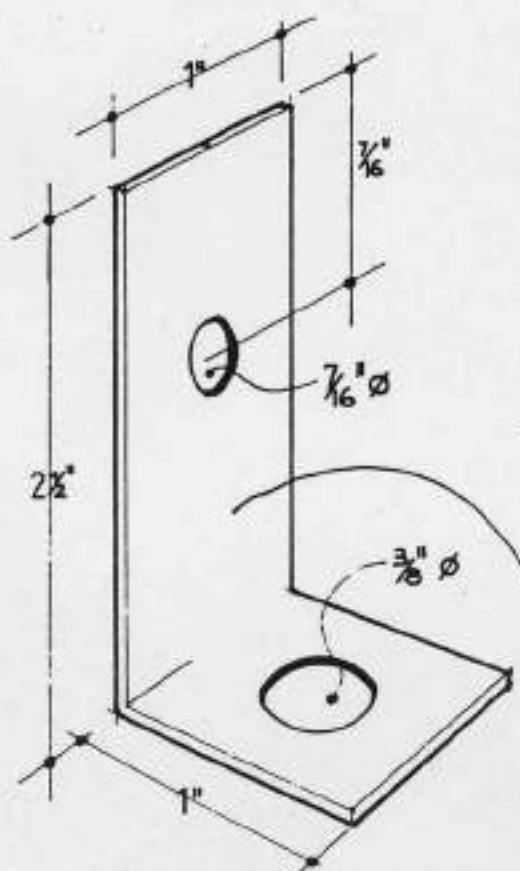

SUPPORT BRACKET
flexible pipe to caliper

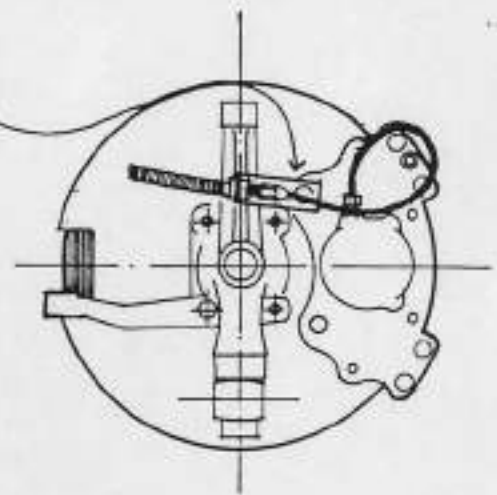

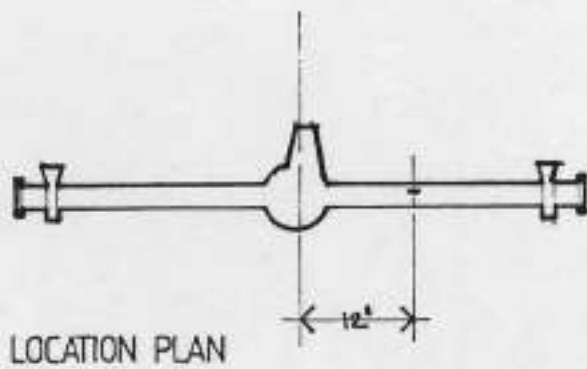
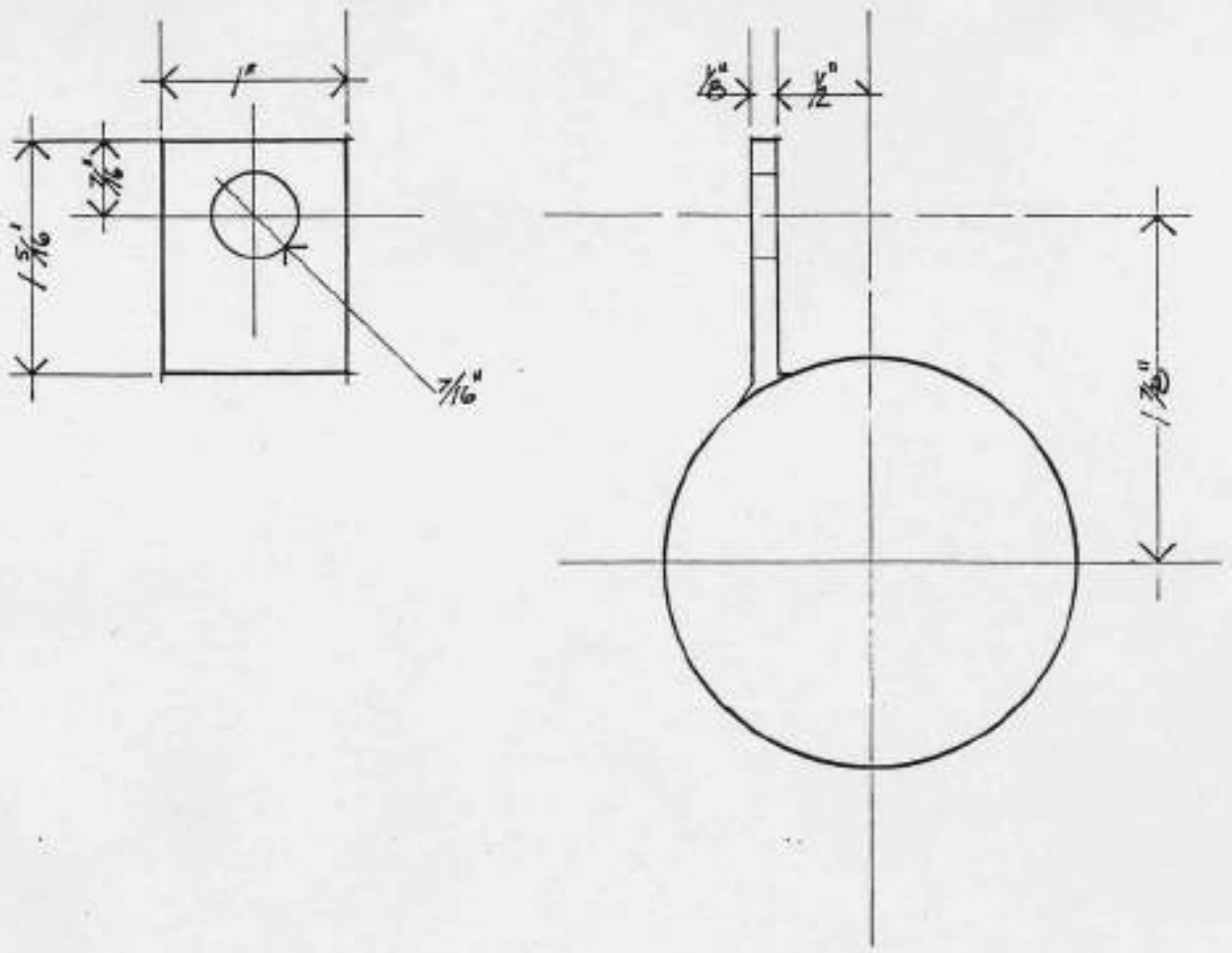

BRAKE PIPE SUPPORT BRACKET

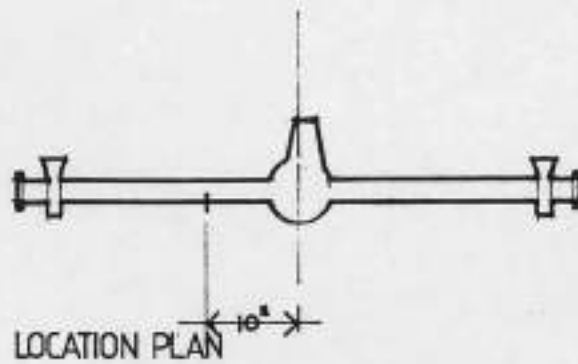
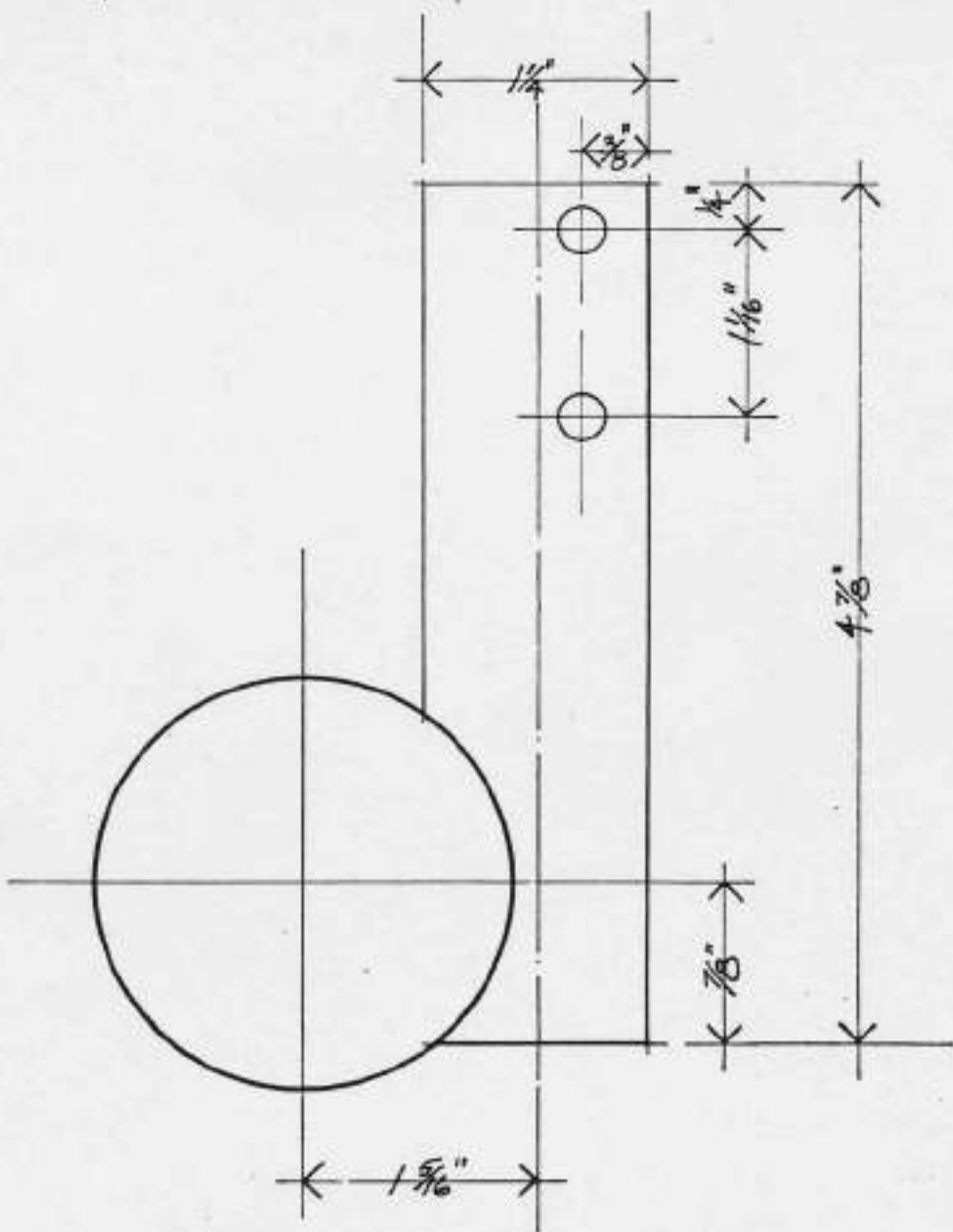

HANDBRAKE BRACKET

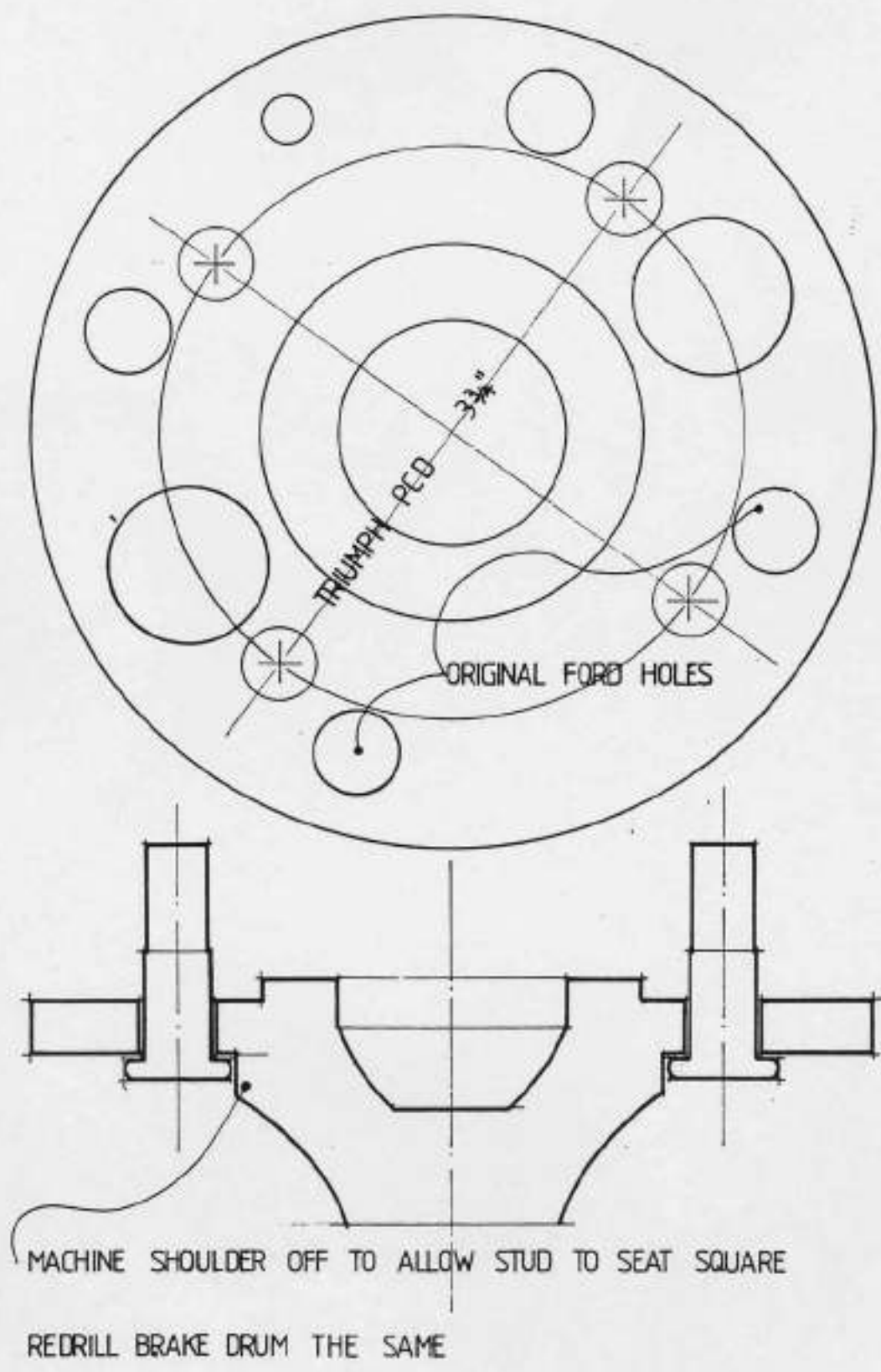

HALF SHAFT MODIFICATIONS

FORD 3L CAPRI OR CORTINA AXLE MODIFIED BY MARCOS

SPRING / DAMPER UNIT

ADJUSTABLE RADIUS ROD

FIXED LENGTH RADIUS RODS

ADJUSTABLE ROSE JOINTED PANHARD ROD

SPECIAL MARCOS BRACKETS

MARCOS REAR SUSPENSION SYSTEM

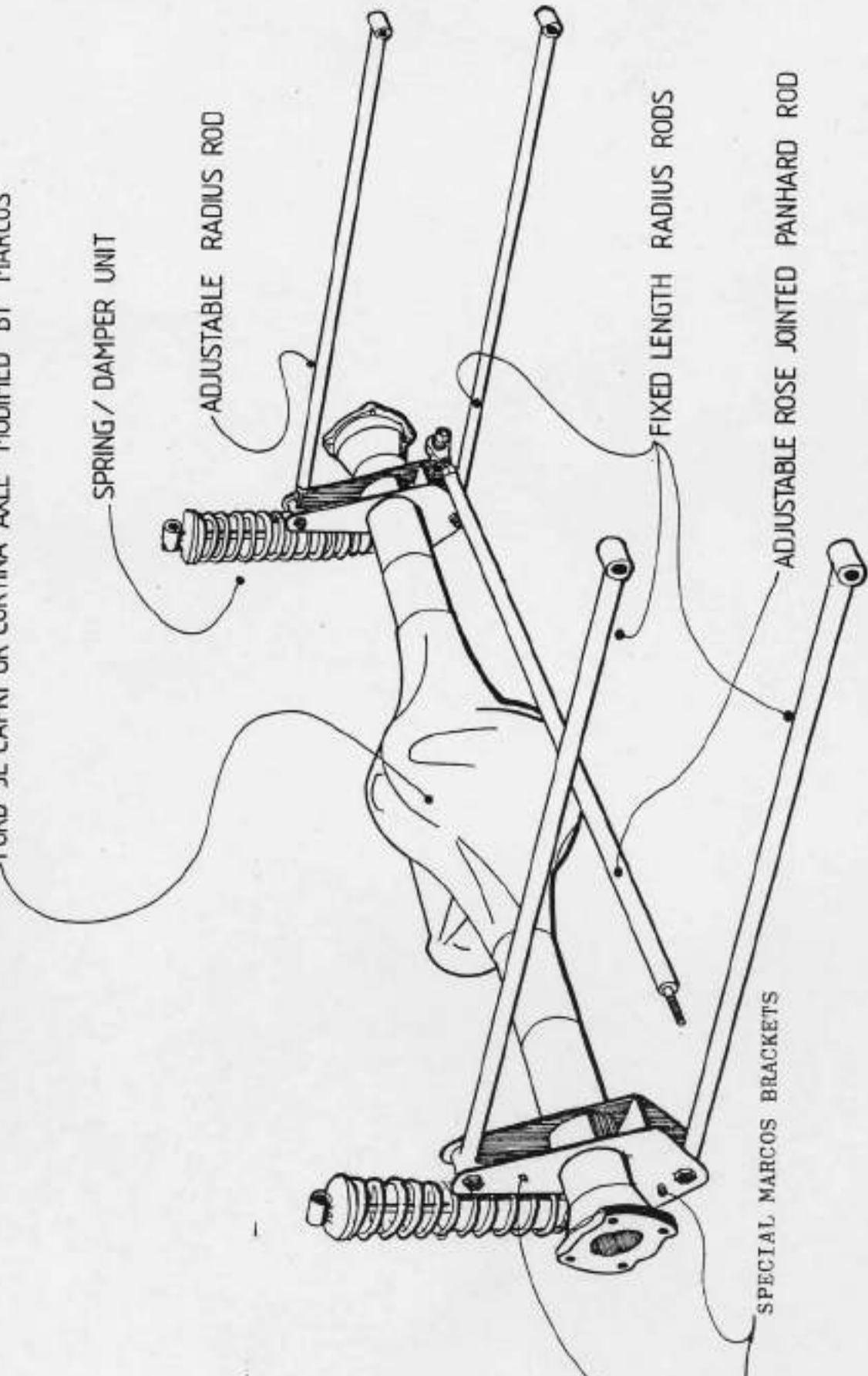

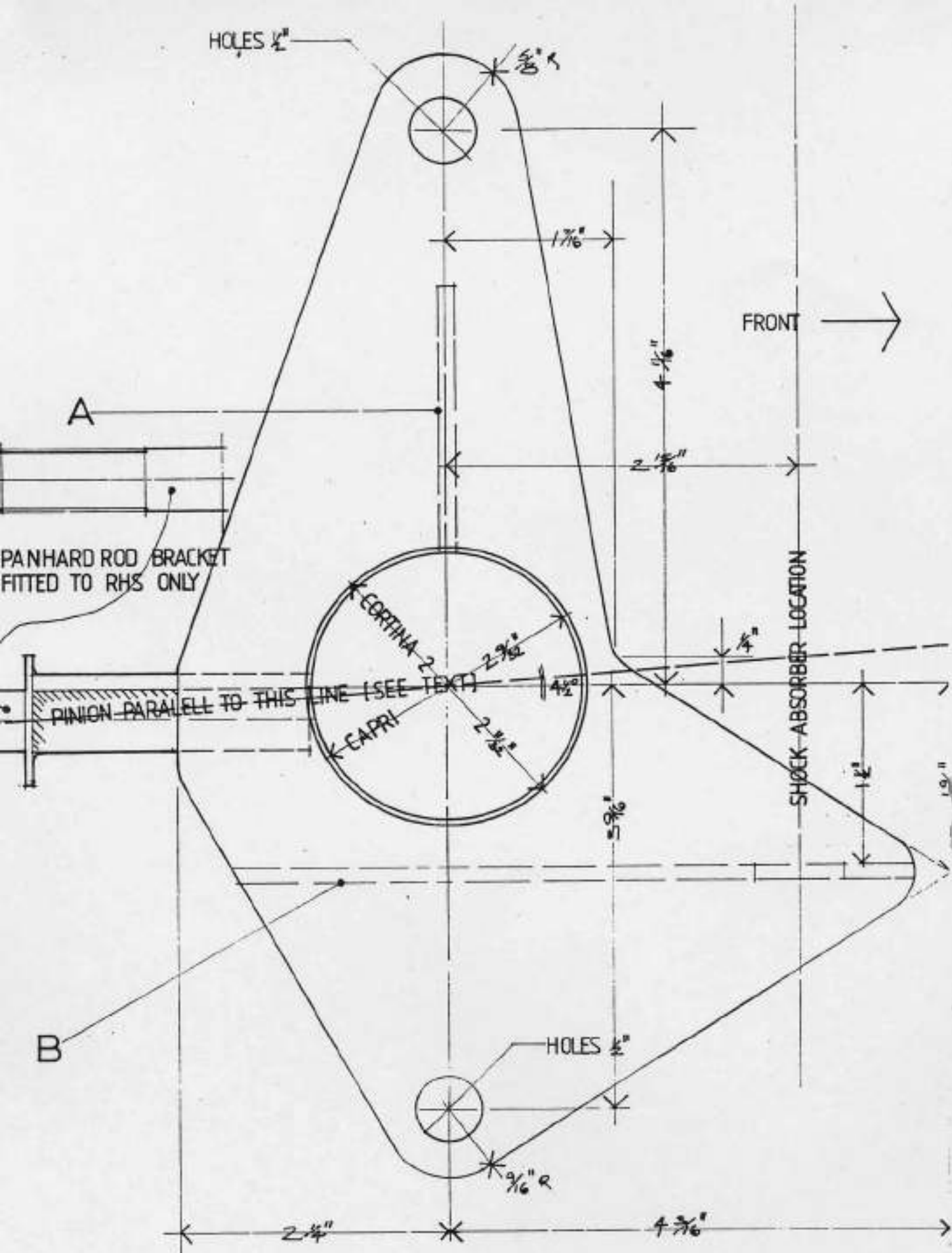

RADIUS ARM BRACKET

STUB HOLES REDRILLED BY MARCOS
TO TRIUMPH P.C.D.

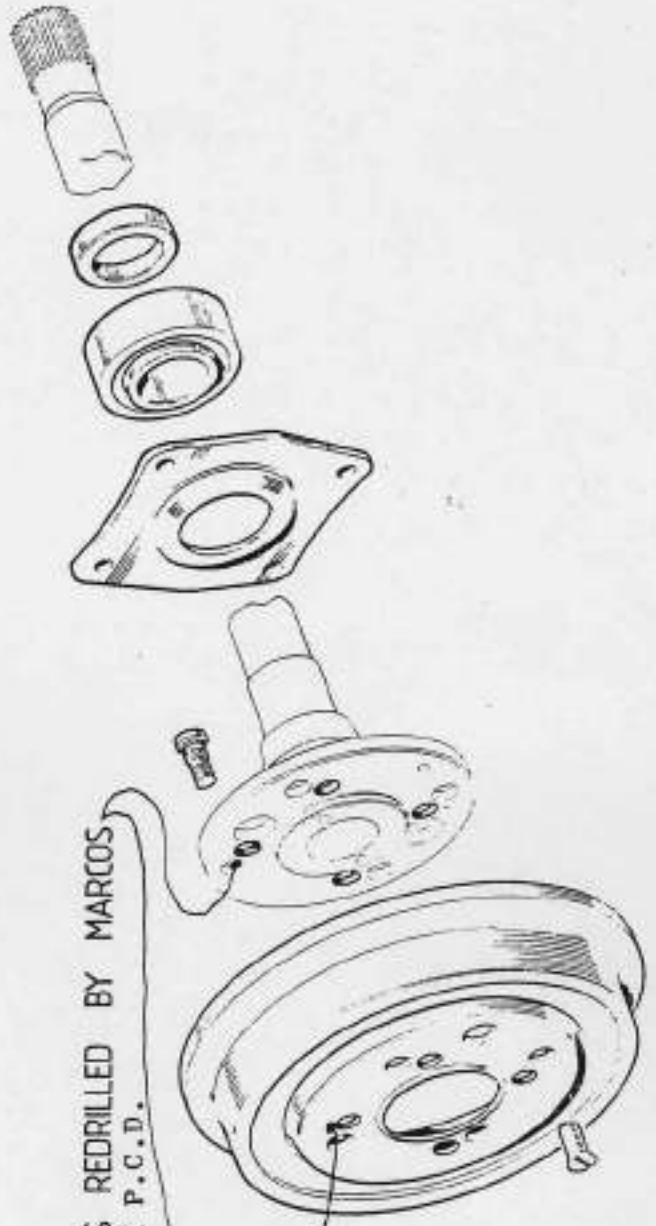

CORTINA MK 2 REAR AXLE AS USED BY MARCOS

GUSSET A
MAKE FROM $\frac{1}{8}$ " MS

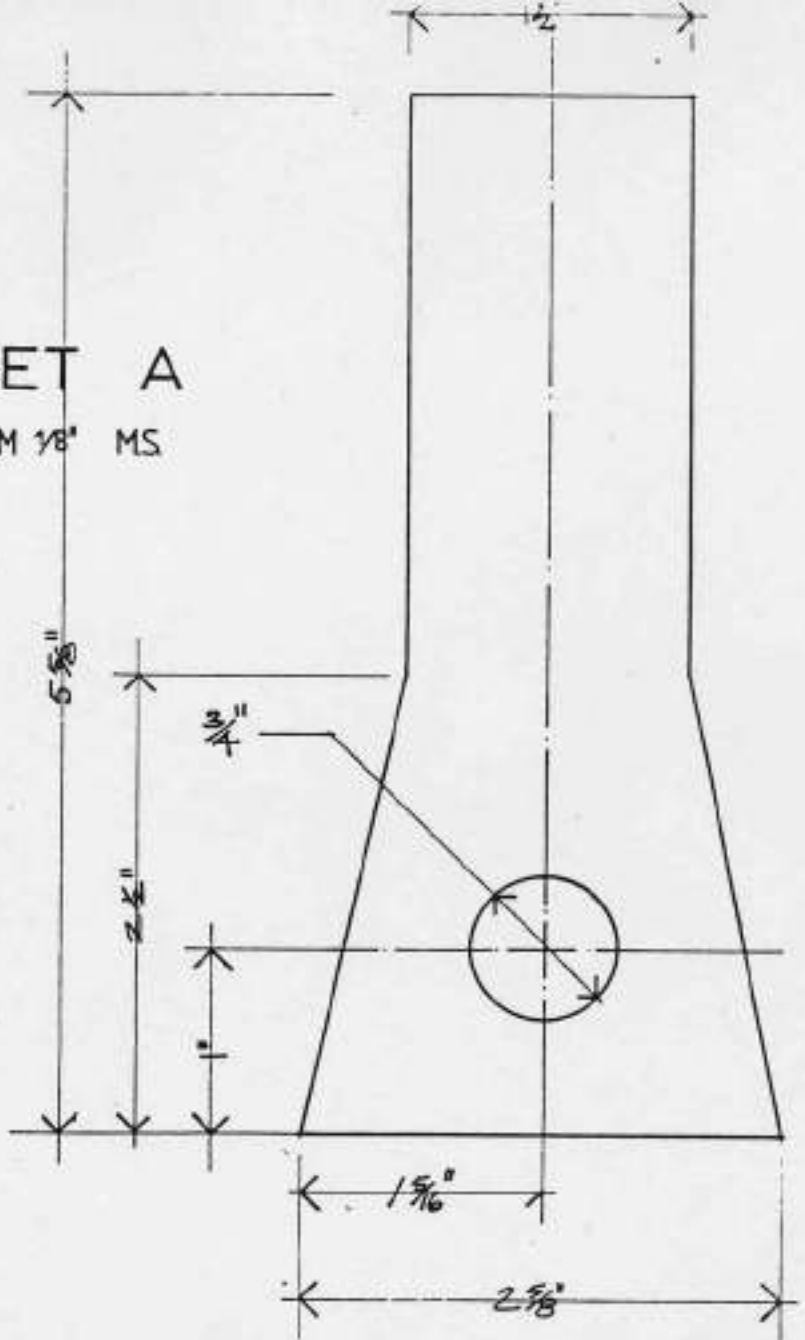

GUSSET A
MAKE FROM $\frac{1}{8}$ " MS

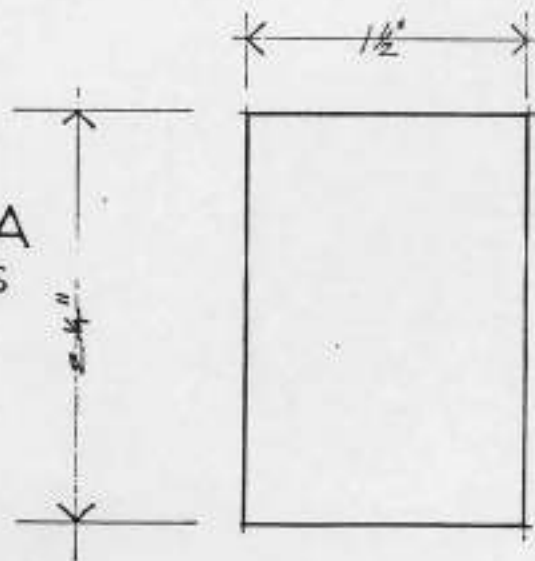

RADIUS ARM BRACKET

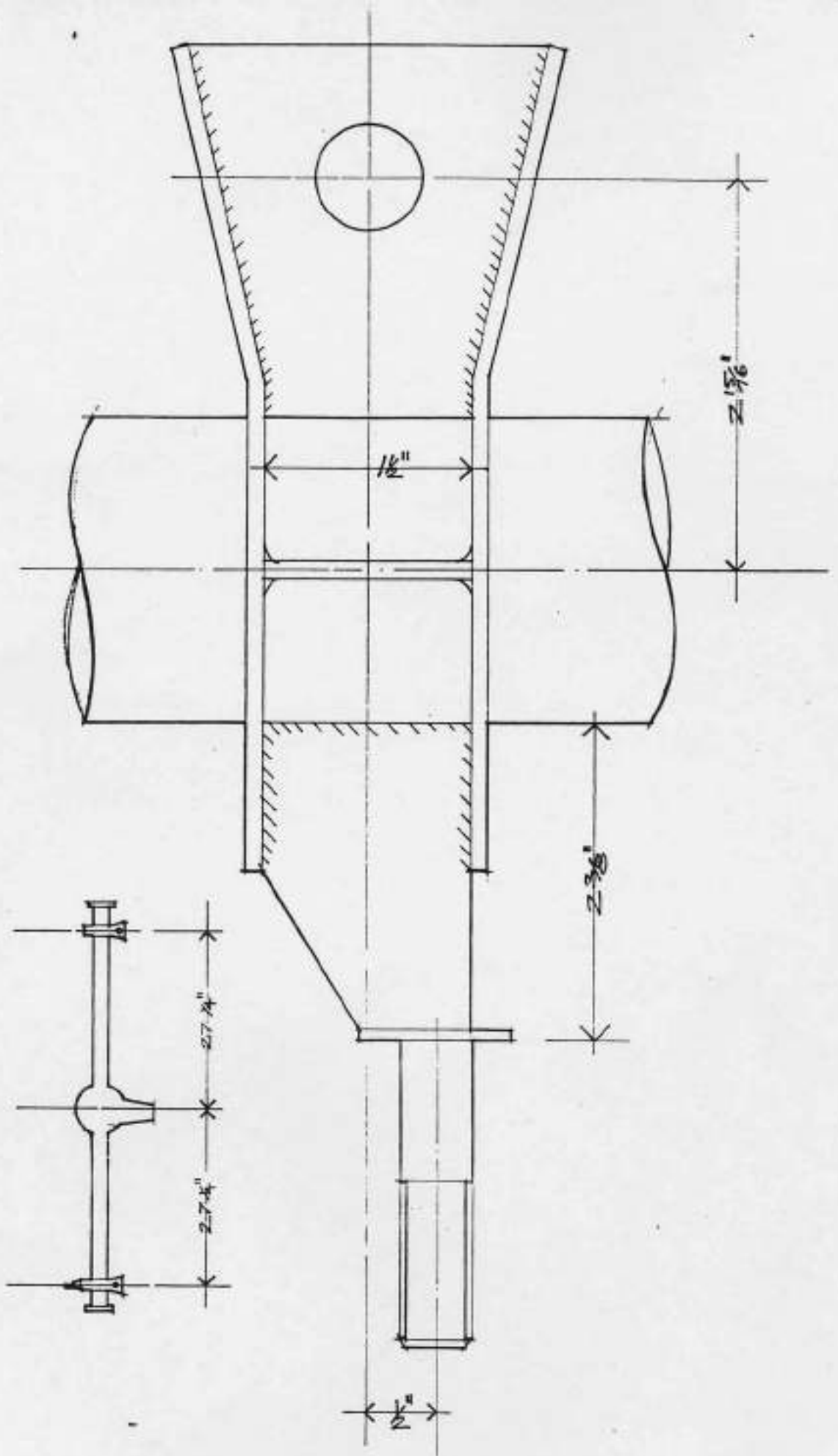

TOP VIEW RIGHT HAND BRACKET

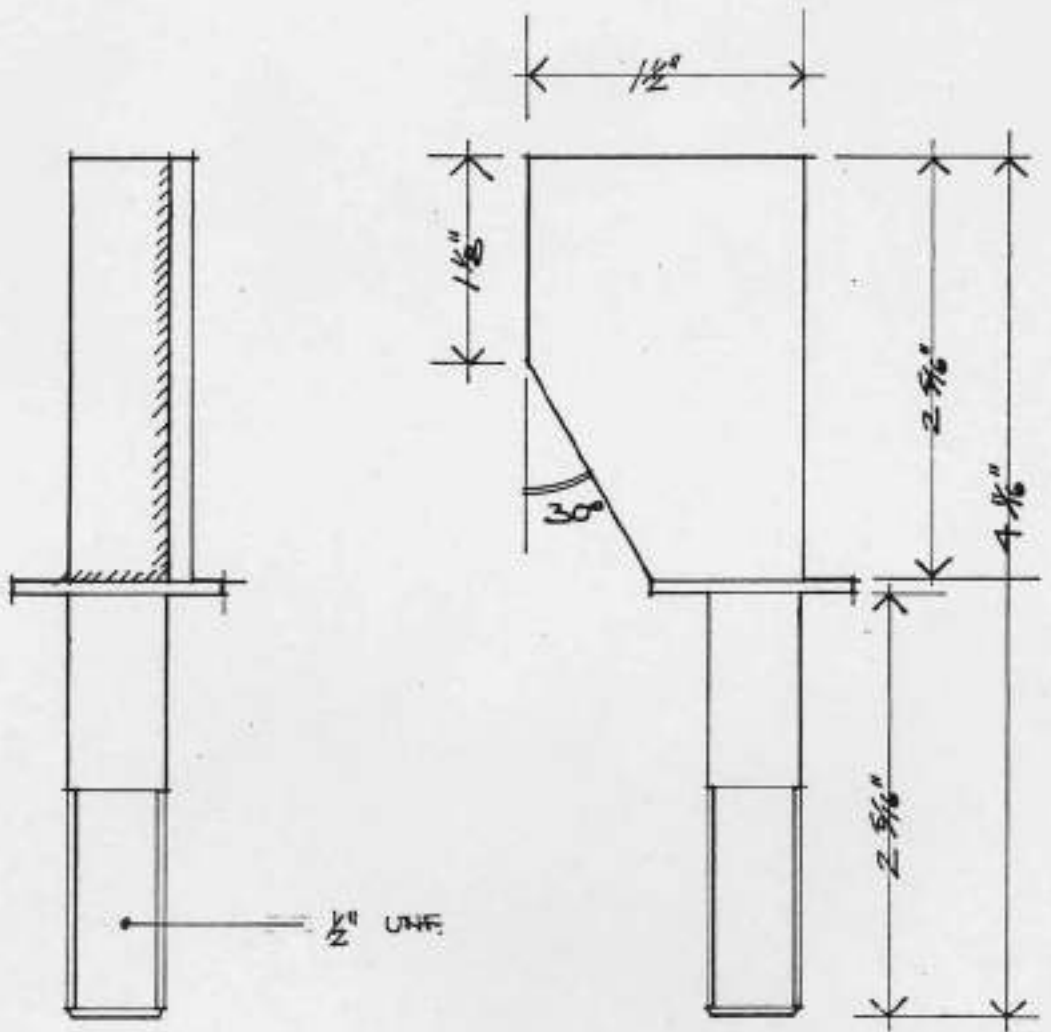
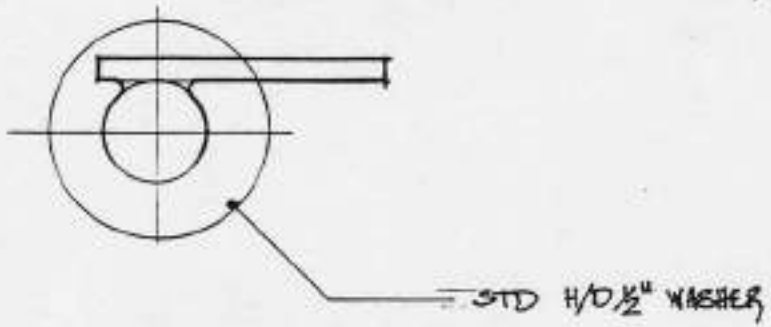

PANHARD ROD BRACKET

All drawings expertly and professionally executed by:
R. A. Faulconer, R.I.B.A.
60 Row Park Terrace,
London, W.1.

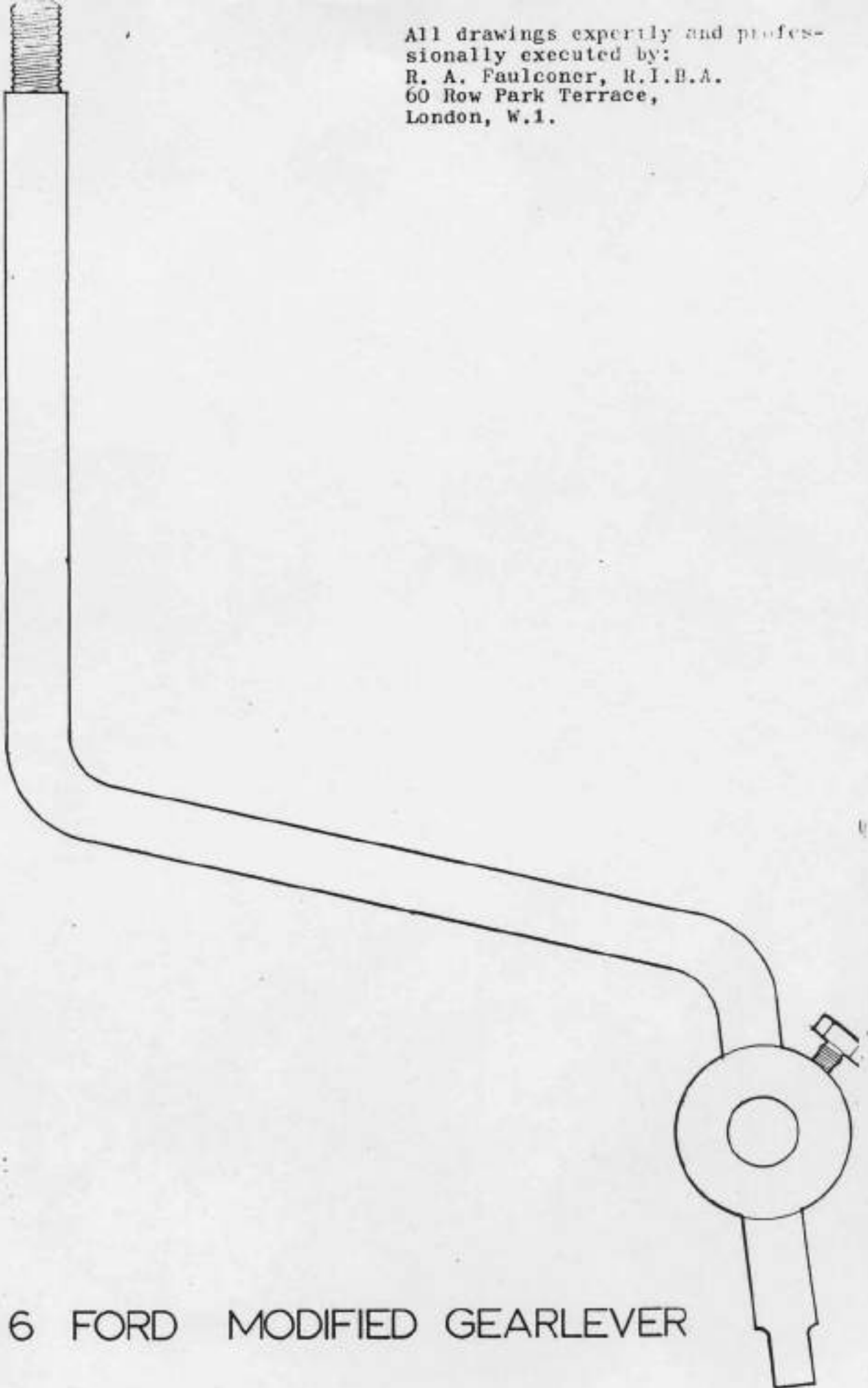

V 6 FORD MODIFIED GEARLEVER