

Thanks for choosing the vehicle manufactured by GAC Motor. For a better driving pleasure, please read the Owner's Manual carefully. This manual covers all instructions necessary for you to fully understand the operation methods and precautions of the vehicle. Proper operation of the vehicle can improve driving safety and prolong the service life.

The Warranty and Maintenance Manual supplied with the vehicle clearly describes the warranty services provided by GAC Motor and the routine maintenance of the vehicle. Please read this manual carefully to know your rights and responsibilities.

After reading this manual, please store it with the vehicle for future reference.

In case of any doubts about this manual, please contact the GAC Motor authorized shop for detailed explanation.

If you have any suggestions or recommendations, please contact GAC Motor through the customer service hotline: 400-813-6666

We are grateful for your support and love for GAC Motor. Have a nice drive!

# Safety Instructions

---

The safety of you and others is crucial, so driving safely is an important responsibility of the driver.



In order to make clear the safety precautions, we provide operation steps and precautions through the various signs on the vehicle and this manual, reminding you of the potential dangers that will hurt you or others.

It is impossible to list all the dangers related to operation and maintenance of the vehicle in the manual, so it is up to you to make a correct judgment in time.

Those important safety instructions are available in many forms, including:

- **Safety signs** - pasted on the vehicle.
- **Safety notes** - the texts marked with warning symbol and warning words including “**WARNING**”, “**CAUTION**” or “**NOTE**” in front.

The meaning of warning words including “**WARNING**”, “**CAUTION**” and “**NOTE**” are as follows:

 <b>WARNING</b>	Very important instructions of which the nonobservance is likely to cause casualties.
 <b>CAUTION</b>	Important instructions of which the nonobservance is likely to cause damage to the vehicle.
 <b>NOTE</b>	General instructions of which the nonobservance could not cause injuries.

- Safety Section-Safety precautions concerning driver and occupant.
- Instructions-How to operate the vehicle correctly and safely.

The manual contains important safety information - please read it thoroughly.

<b>1. Important safety precautions</b>	<b>1</b>
<b>2. Picture index</b>	<b>3</b>
2.1 Exterior	3
2.2 Interior	7
<b>3. Instructions for safe operation</b>	<b>11</b>
3.1 Safe driving	11
3.1.1 General description	11
3.1.2 Correct sitting posture of the driver and passengers	12
3.2 Seat belt	13
3.2.1 Why must you fasten the seat belt	13
3.2.2 Seat belt	15
3.3 Supplemental restraint system (SRS)	18
3.3.1 Cases where the airbags may deploy	23
3.3.2 Cases where the airbags might not deploy	24
3.4 Child restraint	25
3.4.1 General description	25
3.4.2 Child safety seat	26
3.4.3 Information about child safety seat	28
3.4.4 Correct installation of child safety seat	30
3.5 Exhaust gas hazard	34
3.6 Safety label	35

<b>4. Operation of systems and equipment</b>	<b>36</b>
4.1 Cab	36
4.1.1 Steering wheel	36
4.1.2 Instrument cluster	38
4.1.3 Indicator lamp	55
4.2 Vehicle locking and unlocking	59
4.2.1 Remote control key	59
4.2.2 Bluetooth key*	63
4.2.3 Emergency mechanical key	77
4.2.4 Door lock system	77
4.2.5 Door	82
4.2.6 Trunk lid	83
4.2.7 Hood	85
4.2.8 Power window	86
4.2.9 Power sunroof *	89
4.2.10 Basic operation of body anti-theft system	93
4.3 Lamps and vision	94
4.3.1 Exterior lamps	94
4.3.2 Interior lamps	100
4.3.3 Wiper combination switch	103
4.3.4 Windshield	105
4.3.5 Exterior rearview mirror	106
4.3.6 Sun visor	109

# Contents

---

4.4	Seats and storage facilities.....	110			
4.4.1	Headrest .....	110			
4.4.2	Front seat.....	111			
4.4.3	Rear seat .....	115			
4.4.4	Storage facilities .....	116			
4.4.5	Low battery reminder .....	119			
4.4.6	USB interface/power outlet.....	119			
4.4.7	Mobile phone wireless charging system* .....	121			
4.4.8	Trunk .....	124			
4.4.9	Accessories and modification .....	126			
4.5	HVAC system.....	128			
4.5.1	General description.....	128			
4.5.2	HVAC system.....	129			
4.5.3	A/C air outlet.....	136			
4.6	AV system .....	137			
4.6.1	Console audio control button .....	137			
4.6.2	Right control button of steering wheel * .....	138			
4.6.3	Steering wheel custom button* .....	139			
4.6.4	Basic operations .....	142			
4.6.5	Personal account* .....	148			
4.6.6	OTA upgrade * .....	151			
4.6.7	Radio .....	154			
4.6.8	Local music.....	155			
4.6.9	Bluetooth function .....	156			
4.6.10	System settings (applicable to the vehicle models with AV host) .....	158			
4.6.11	System setting (applicable for AVNT models).....	163			
4.7	GAC Motor T-BOX* .....	169			
4.7.1	General description.....	169			
4.7.2	Download APP on mobile phone .....	170			
4.7.3	Emergency Rescue * .....	171			
4.7.4	Feature list .....	172			
	<b>5. Driving guide.....</b>	<b>174</b>			
5.1	Starting and driving.....	174			
5.1.1	Door latch and inside handle .....	174			
5.1.2	Start the engine .....	175			
5.1.3	Shut down the engine .....	176			
5.1.4	Instruction for the gear .....	177			
5.1.5	4 + X driving mode .....	181			
5.1.6	SPORT + (Extreme) mode unlocked ...	183			
5.1.7	Launch control .....	187			
5.1.8	Exhaust sound wave* .....	188			
5.2	Brake system .....	189			
5.2.1	Service brake .....	189			
5.2.2	EPB system (EPB).....	192			
5.3	Electronic service brake system .....	196			
5.3.1	ESP (ESP).....	196			
5.3.2	ESP (ESP) TOP SPEED mode .....	198			

5.3.3	Anti-lock brake system (ABS).....	198
5.3.4	HHC (HHC) .....	199
5.4	Driver assistance system .....	200
5.4.1	Cruise control system * .....	200
5.4.2	ACC * .....	202
5.4.3	Traffic Jam Assist (TJA)/ Integrated cruise assist (ICA)* .....	211
5.4.4	Speed limit sign identification* .....	217
5.4.5	Intelligent speed limit* .....	219
5.4.6	Forward collision mitigation (FCM)* .....	220
5.4.7	LKA* .....	225
5.4.8	Intelligent high beam* .....	231
5.4.9	BSD system* .....	233
5.4.10	Rear crossing traffic alert system* .....	236
5.4.11	Door opening warning system* .....	238
5.4.12	Rear approach alert system* .....	241
5.4.13	Radar and camera sensors * .....	242
5.4.14	TPMS .....	246
5.4.15	On-board ETC unit* .....	247
5.4.16	Cabin monitoring system* .....	248
5.5	PAS .....	253
5.5.1	RPA .....	253
5.5.2	Reverse image system * .....	258
5.5.3	Around View Monitor (AVM)* .....	260
5.6	Electric power steering (EPS).....	267

5.7	Driving skills .....	268
5.7.1	Traffic safety inspection .....	268
5.7.2	Driving in running-in period .....	268
5.7.3	Driving essentials .....	270
5.7.4	Efficient use of vehicle .....	272
5.7.5	Fire prevention .....	272

## **6. Operation and maintenance ..... 274**

6.1	Maintenance instructions .....	274
6.2	Internal maintenance .....	274
6.3	External maintenance .....	276
6.3.1	Maintenance of fighter green paintwork * .....	280
6.4	Inspecting and adding fluids .....	281
6.4.1	Fuel .....	281
6.4.2	Engine oil .....	283
6.4.3	Coolant .....	286
6.4.4	Windshield washer fluid and wiper blades .....	288
6.4.5	Brake fluid .....	290
6.4.6	Battery .....	292
6.5	A/C filter .....	293
6.6	Replacing bulbs .....	295
6.7	Wheels .....	298
6.8	Tire chain .....	303

# Contents

---

## 7. Technical data ..... 305

- 7.1 Identifications .....305
- 7.2 Dimensions & parameters of vehicle .....307
- 7.3 Vehicle mass, engine and fluid parameters...308
- 7.4 Parameters of transmission, chassis and lamps ..... 311

## 8. Accident handling ..... 315

- 8.1 Driver's tools, spare tire \* .....315
- 8.2 Use of warning triangle .....316
- 8.3 Use of reflective vest .....317
- 8.4 Inflator pump and tire sealer \* .....317
- 8.5 Replacing flat tire\* .....322
- 8.6 Microwave window .....325
- 8.7 Fuse.....325
  - 8.7.1 Fuses in instrument panel PDU ..... 328
  - 8.7.2 Fuses in engine compartment PDU..... 331
  - 8.7.3 Fuse in PFB ..... 334
- 8.8 Emergency start .....335
- 8.9 Vehicle towing.....337
- 8.10 Getting out of a trap .....340

## 9. Environmental protection information ..... 341

- 9.1 Environmental protection information code ...341
- 9.2 Environmental protection information .....342

# 1. Important safety precautions

## ◆ Be sure to fasten the seat belt correctly

The seat belt is the best protection device in the event of a collision. Airbags are only designed as auxiliaries, rather than replacements, of the seat belts, so even if the vehicle is equipped with airbags, make sure that you and the passengers always fasten the seat belts correctly.

## ◆ Do not leave children in an unattended vehicle

Do not leave children in an unattended vehicle, as injury or even death may occur if they trigger a control device accidentally, or when the vehicle is moved accidentally and collided with other objects due to their mis-operation, and besides, the temperature inside the vehicle may reach an extreme condition, depending on the ambient temperature.

## ◆ Protect all children

Children aged 12 or under should be properly restrained in the rear seats rather than the front seats. Child safety seats shall be used for infants and toddlers; and child safety seats and three-point seat belts shall be used for older children.

## ◆ Beware of danger of airbag

Airbags can save lives, but they can also cause serious or fatal injuries to occupants who are too close to the airbags or improperly restrained.

Airbags pose the greatest risk to infants, toddlers and short adults, so please follow all instructions and warnings in this manual.

## ◆ Never drink and drive

Drinking alcohol, even a little, will reduce your response capability, and your reaction time after drinking will become longer, so drinking and driving is strictly prohibited.

## ◆ During driving, please abide by the road traffic safety laws and yield to pedestrians.

## ◆ Be sure to pay attention to driving safety

Traffic accident will occur if you are busy answering the phone or handling other things so that you can not pay attention to road conditions, other traffics and pedestrians during driving. Please avoid distraction during driving.

## ◆ Control speed

Excessive speed is one of the main causes of traffic accidents. The faster the speed is, the greater the risk will be. Therefore, please choose the appropriate speed for safe driving according to the actual road conditions.

## ◆ Regular maintenance

Tire burst or mechanical failure is very dangerous. In order to reduce the possibility of such problems, please check the tire pressure and status frequently, and carry out regular maintenance as specified in the *Warranty Manual*.

# 1. Important safety precautions

---

## Event data recorder (EDR)

This vehicle is equipped with an event data recorder (EDR). The EDR is mainly designed to record data in the event of certain collisions (such as airbag deployment or collision with a barrier), so as to help understand the operation of the vehicle system. EDR is specially used to record data related to vehicle dynamic control and safety systems in a short period of time. However, depending on the severity and type of collision, no data may be recorded or the recorded data may be overwritten by new data.

The data specially recorded by the EDR of this vehicle include:

- The depressed status of the brake pedal (if applicable).
- The vehicle speed.
- The longitudinal acceleration
- Vehicle identification number

These data help better understanding the situation in the event of a collision and personal injury, and are used to assist accident analysis.

### **i** NOTE

The EDR will record data only when a certain degree of collision occurs to the vehicle; EDR will not record data during normal driving.

## EDR data disclosure

Except for the following circumstances, GAC Motor will not disclose the data recorded in the EDR to third parties:

- Reaching an agreement with the owner (or the lessee of the rental vehicle).
- At the official request of the police, courts or government agencies.

If necessary, the data will be used in:

- Research on vehicle safety performance.

## How to obtain EDR data reading tool

Special technical equipment is required to read EDR data. For more information, please contact GAC Motor authorized shop.



### 2.1 Exterior

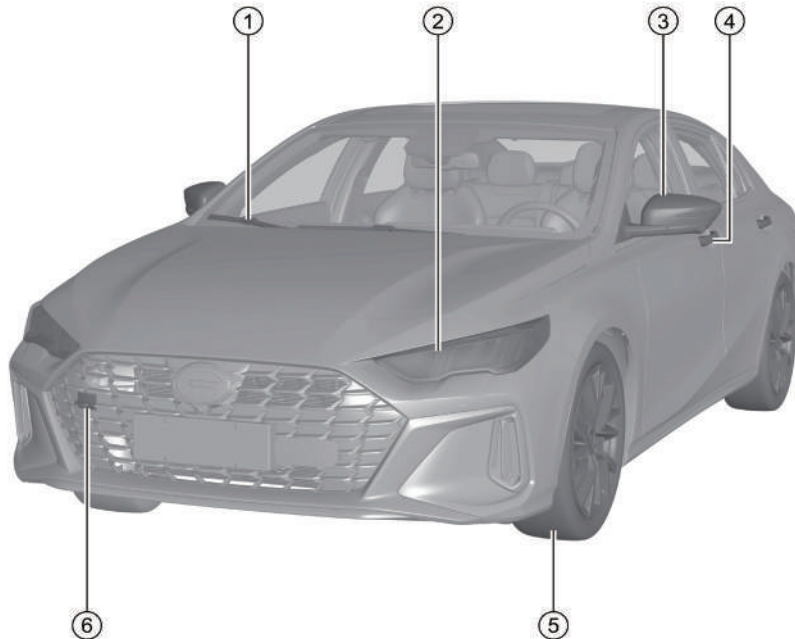

#### Model with horizontal grill

- ① Wiper
  - Replacing front windshield wiper blades => [See page 289](#)
- ② Front combination lamp
  - Turning on lamps => [See page 94](#)
  - Specifications of front combination lamp bulbs => [See page 313](#)
- ③ Exterior rearview mirror => [See page 107](#)
  - Side turn signal lamp => [See page 94](#)
  - Specifications of side turn signal lamp => [See page 313](#)
- ④ Door lock hole => [See page 78](#)
- ⑤ Wheel => [See page 298](#)
- ⑥ Front towing eye => [See page 337](#)

## 2. Picture index

---

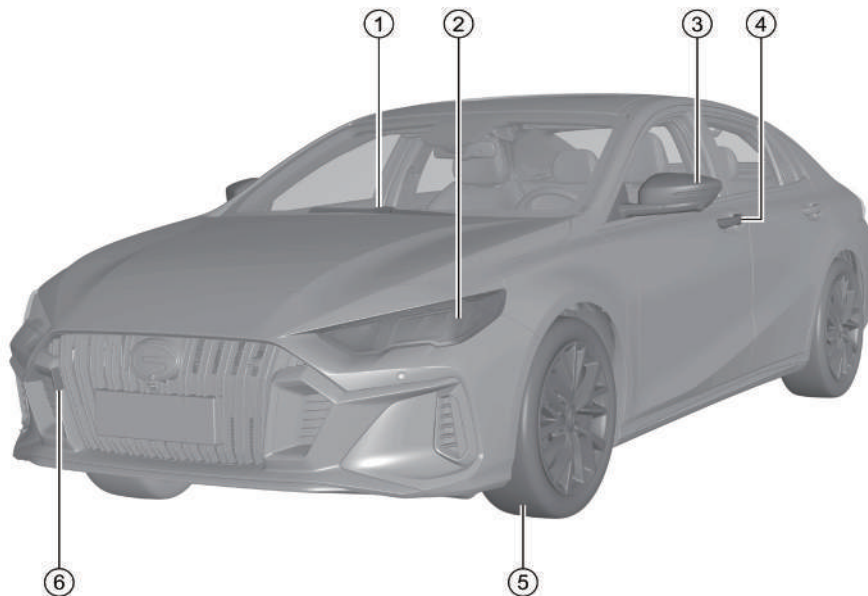

### Model with vertical grille

- ① Wiper
  - Replacing front windshield wiper blades => [See page 289](#)
- ② Front combination lamp
  - Turning on lamps => [See page 94](#)
  - Specifications of front combination lamp bulbs => [See page 313](#)
- ③ Exterior rearview mirror => [See page 107](#)
  - Side turn signal lamp => [See page 94](#)
  - Specifications of side turn signal lamp => [See page 313](#)
- ④ Door lock hole => [See page 78](#)
- ⑤ Wheel => [See page 298](#)
- ⑥ Front towing eye => [See page 337](#)

## 2. Picture index

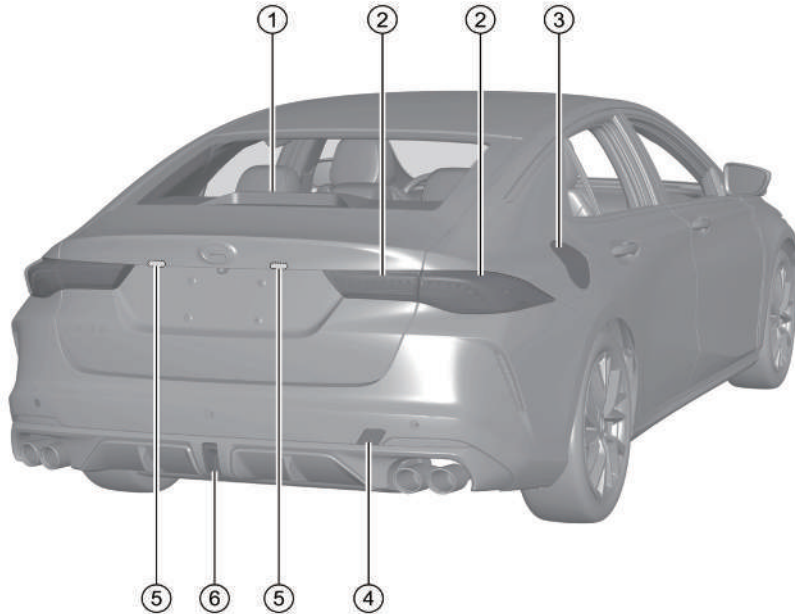

- ① High-mounted stop lamp
  - Specifications of high-mounted stop lamp => [See page 313](#)
- ② Rear combination lamp
  - Specifications of rear combination lamp bulbs => [See page 313](#)
- ③ Fuel tank cap => [See page 281](#)
- ④ Rear towing eye => [See page 337](#)
- ⑤ License plate lamp
  - Specifications of license plate lamp => [See page 313](#)
- ⑥ Rear fog lamp => [See page 98](#)
  - Specifications of rear fog lamp => [See page 313](#)

## 2. Picture index

---

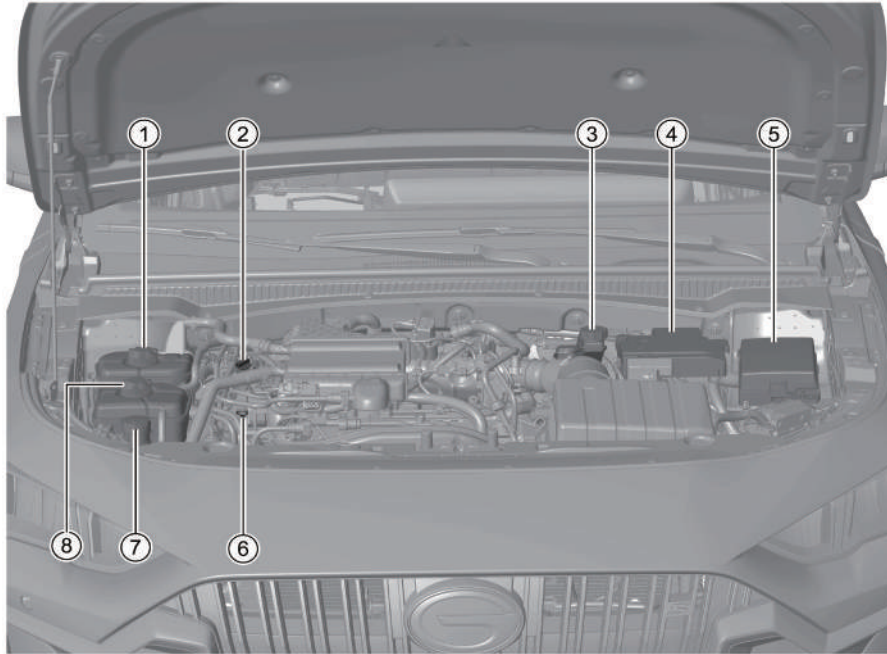

### Engine compartment

- ① Intercooler coolant reservoir => See page 287
- ② Oil filler cap => See page 285
- ③ Brake fluid reservoir => See page 291
- ④ Battery => See page 292
- ⑤ Engine compartment power distribution unit => See page 325
- ⑥ Oil dipstick => See page 284
- ⑦ Windshield washer fluid reservoir => See page 288
- ⑧ Expansion tank => See page 287

### 2.2 Interior

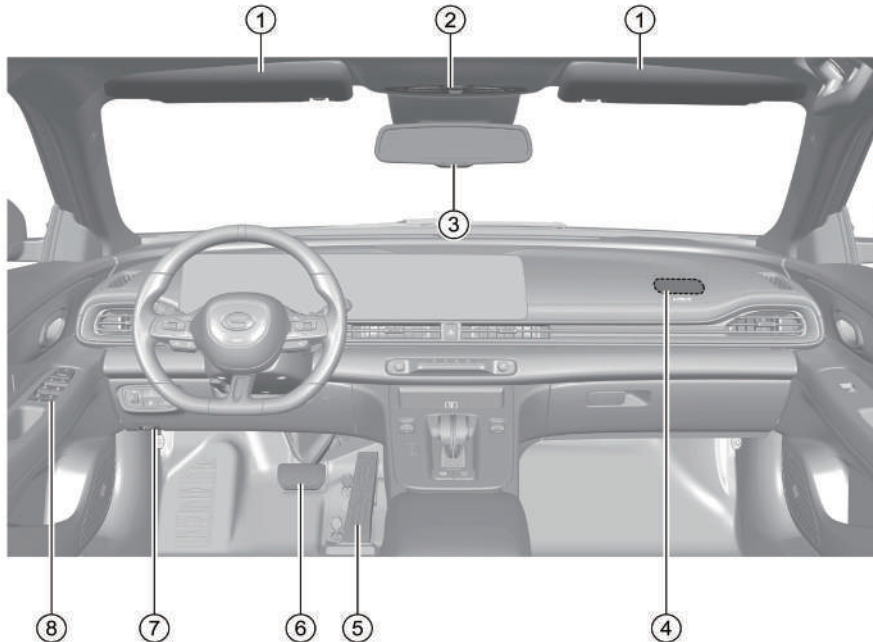

- ① Sun visor => See page 109
- ② Front dome lamp => See page 100
  - Power sunroof control button\* => See page 89
  - SOS button \* => See page 171
- ③ Interior rearview mirror => See page 106
- ④ Front passenger's frontal airbag => See page 20
- ⑤ Accelerator pedal
- ⑥ Brake pedal
- ⑦ Engine hood release handle => See page 85
- ⑧ Driver's power window control button => See page 86
  - Central locking button => See page 77
  - Exterior rearview mirror adjusting button => See page 107

## 2. Picture index

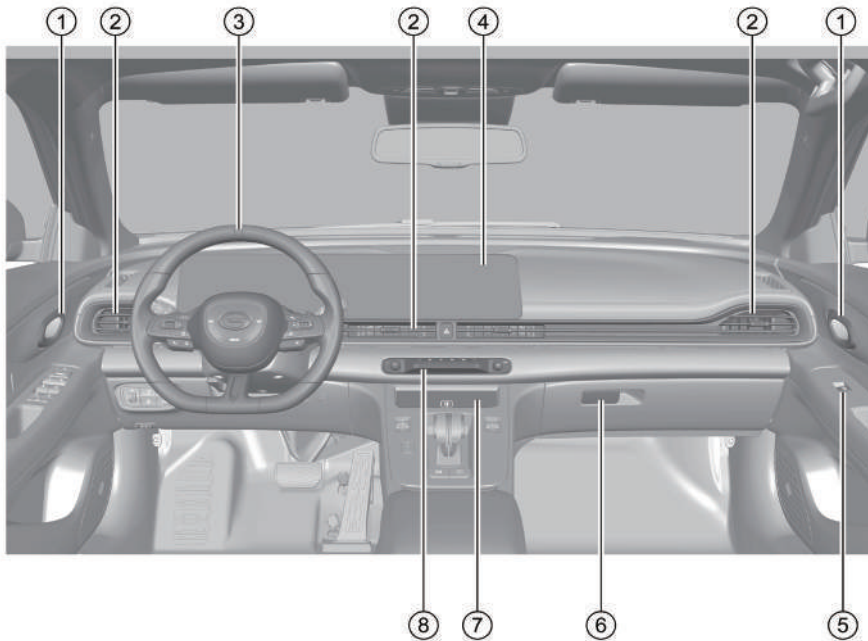

- ① Inside handle => See page 77
- ② A/C air outlet => See page 136
- ③ Steering wheel => See page 36
  - Steering wheel buttons => See page 37
  - Driver's frontal airbag => See page 19
  - Paddle shifter\* => See page 180
- ④ AV system => See page 137
- ⑤ Passenger's power window control button => See page 87
- ⑥ Glove box opening handle => See page 118
- ⑦ Instrument panel front storage compartment => See page 116
  - Mobile phone wireless charging area\* => See page 121
- ⑧ A/C system control panel => See page 129

## 2. Picture index

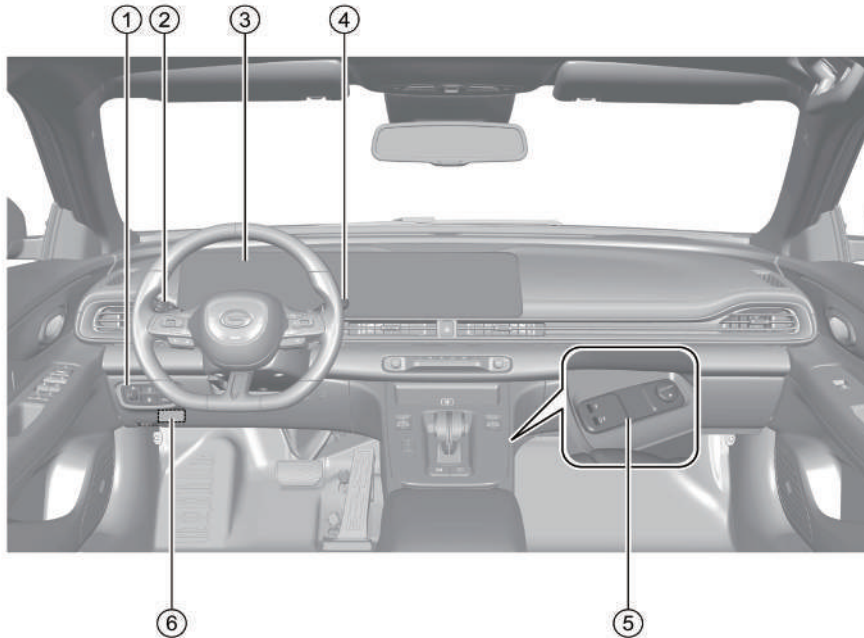

- ① Instrument panel left switch block
  - Manual headlamp leveling knob => See page 98
  - Trunk lid unlocking button => See page 83
  - Fuel tank cap unlocking button => See page 281
  - ESP OFF button => See page 196
- ② Lamplight combination switch => See page 94
- ③ Instrument cluster => See page 38
  - Indicator lamp => See page 55
- ④ Wiper combination switch => See page 103
- ⑤ USB port => See page 120
  - 12V power outlet => See page 119
- ⑥ Instrument panel PDU => See page 325

## 2. Picture index

---

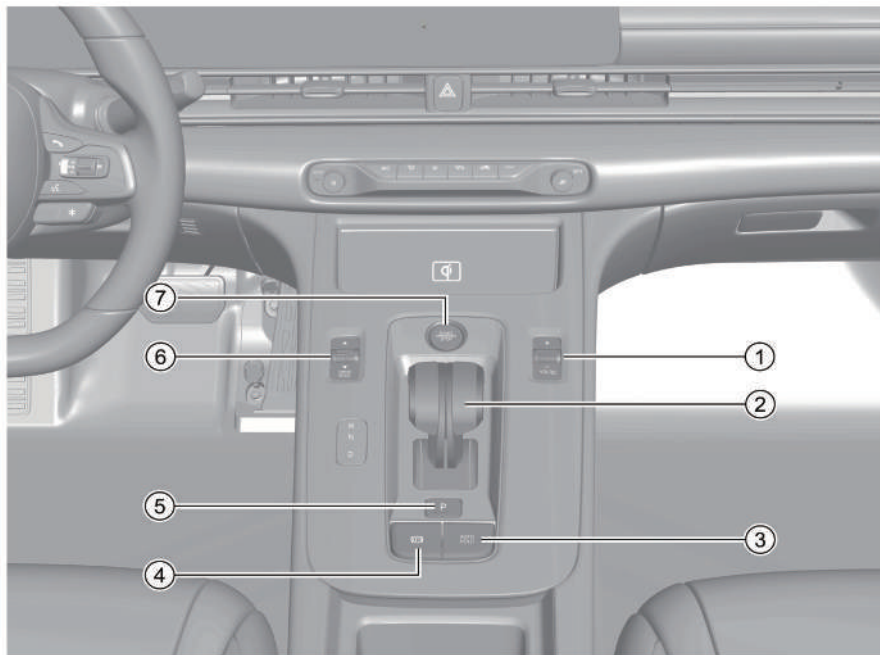

- ① Volume adjustment/display OFF button => See page 137
- ② Transmission gearshift lever => See page 177
- ③ AUTO HOLD button => See page 195
- ④ EPB button => See page 192
- ⑤ "P" button => See page 178
- ⑥ Driving mode knob => See page 179
- ⑦ START/STOP button => See page 174



### 3.1 Safe driving

#### 3.1.1 General description

This section introduces important information, operating essentials, recommendations and safety precautions for safe driving. For the safety of you and the passengers, please read carefully and follow the relevant regulations.

#### NOTE

Please always keep the *Owner's Manual* in the vehicle. If you lend or resell the vehicle to someone else, be sure to hand the complete set of accompanying documents over to the new owner.

The following inspections must be carried out before driving:

- The following inspections must be carried out before driving:
- Check that all lamps are working properly.
- Check that the fuel level is normal.
- Check that the coolant level is normal.
- Check that the windshield washer fluid level is normal.
- Check that the windshield washer fluid level is normal.
- Check that the engine hood is closed and locked properly.
- Check that the tire pressure is normal.
- Check that all windows are clear and have a good view.
- Check that no objects obstruct the movement of the driver's foot pedals.
- Adjust the seat, head restraint and rearview mirror according to your body height and shape.
- Use appropriate child safety seats to protect children and help them fasten the seat belts correctly.
- Fasten the seat belt correctly and remind all passengers in the vehicle to fasten the seat belts correctly.

#### WARNING

**When installing the driver's floor mat, please observe the following precautions:**

- Do not overlap two or more floor mats.
- Do not make the bottom surface of the floor mat upward or back-to-front.
- Do not use floor mats that are incompatible with this model.

#### CAUTION

- Do not distract yourself from external factors during driving.
- Do not drive the vehicle when your response capability reduces, such as due to medicines, alcohol, or drugs.
- Strictly abide by traffic regulations.

## 3. Instructions for safe operation

### 3.1.2 Correct sitting posture of the driver and passengers

#### Correct sitting posture of the driver

The driver's sitting posture directly affects his/her fatigue level and driving safety. Before driving, the driver shall carry out the following operations:

- Sit up straight and adjust the seat back to a suitable position so that your back fits completely the seat back.
- Adjust the seat position so that all pedals can be operated effectively with slightly bent legs.
- Correctly adjust the headrest. => See page 110
- Fasten the seat belt correctly. => See page 16
- Adjust the steering wheel position. => See page 36



#### WARNING

**Do not adjust the seat, headrest or steering wheel during driving; otherwise the vehicle may be out of control, leading to an accident.**

#### Correct sitting posture of the passengers

To guarantee the safety of the passengers and reduce the risk of casualties, the passengers should:

- Sit up straight and adjust the head restraint of the seat correctly. => See page 110
- Adjust the distance between the seat and the instrument panel as demanded (for front passenger).
- Adjust the seat back until the back fits completely the seat back (for front passenger).
- Fasten the seat belt correctly. => See page 16
- Place both feet on the floor.
- Use appropriate child safety seat in accordance with applicable regulations for children. => See page 26



#### WARNING

- It is forbidden to install a child safety seat in the front passenger's seat.
- If the front passenger is too close to the instrument panel, the SRS will not provide effective protection.
- When the vehicle is running, be sure to maintain a correct sitting posture and fasten the seat belt correctly, so as to avoid unexpected injuries in case of emergency braking or accidents.

## 3. Instructions for safe operation

### 3.2 Seat belt

#### 3.2.1 Why must you fasten the seat belt

Protection of the driver and passengers by seat belts



In the event of a vehicle collision, the seat belt, if fastened correctly, can restrain the driver and passengers in a proper position and slow down the inertia of their forward movement, thus preventing them from being thrown forward, and at the same time allow airbags to give them the best protection, thus reducing their impact injury as much as possible.

In the event of a collision, the seat belt will assist other safety systems in simultaneously absorbing the energy generated by the collision, further reducing the injuries suffered by the driver and passengers.

#### **WARNING**

**Airbags cannot replace seat belts. Regardless of whether the car is equipped with airbags, the seat belts should be worn correctly.**

Consequences of not fastening the seat belt

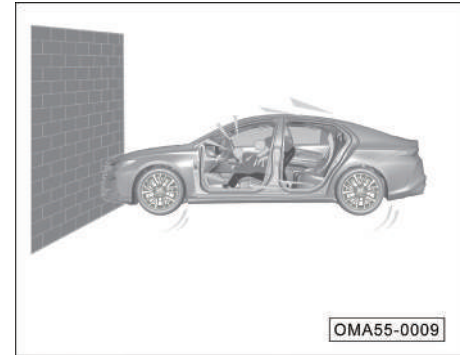

In the event of a collision, the driver or passenger who does not fasten the seat belt will be thrown forward due to inertia and thereby injured.

### 3. Instructions for safe operation

---



Even if the vehicle speed is very low, the force acting on the human body in the event of a collision is so great that the occupant cannot control his or her body with hands at all. In that case, the occupant who does not fasten the seat belt will be thrown forward, and injured if colliding with any interior objects.

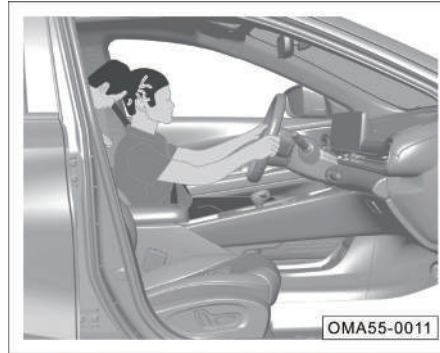

Rear passengers must also fasten the seat belts correctly, otherwise they will be thrown forward when an accident occurs. The occupant who does not fasten the seat belt will not only hurt himself or herself, but also endanger other occupants in the car.

### 3.2.2 Seat belt

#### Seat belt indicator lamp

 : Driver's seat belt indicator lamp

<sub>2</sub> : Front passenger's seat belt indicator lamp

The following alarms will be triggered when the vehicle power switch is set to "ON" position:

- If the driver or front passenger does not fasten the seat belt at a speed lower than 20km/h, the corresponding indicator lamp in the instrument cluster will flash for about 6s and stay on, accompanied by an alarm message.
- If the driver or front passenger does not fasten the seat belt at a speed higher than or equal to 20km/h, the corresponding indicator lamp in the instrument cluster will flash for about 20s and stay on, accompanied by an alarm message and a continuous audible alarm.

#### CAUTION

- Before driving, please check whether there are any heavy objects on the front passenger's seat to avoid the system mistakenly determining that the seat is occupied and issuing a false alarm.
- If the alarm remains on after the seat belt is fastened correctly, it means that the SRS is failed. In that case, please go to the GAC Motor authorized shop for inspection in time.

#### WARNING

**Never insert the substitute of seat belt tongue into the buckle to eliminate the seat belt alarm.**

 : Rear seat belt indicator lamp\*

If rear seat belt indicator lamp is on in white, it indicates that the seat belt is fastened, and if the indicator lamp is on in red, it indicates that the seat belt is not fastened or the SRS is faulty. If the indicator lamp stays red after the seat belt is fastened correctly, it means that the SRS is failed. In that case, please go to the GAC Motor authorized shop for inspection in time.

The rear seat belt indicator lamp is on for 35 s and then goes out in normal cases, and it will light up under the following conditions:

- The rear passenger does not fasten the seat belt when the engine starts.
- The rear passenger does not fasten the seat belt when the rear door is opened/closed.
- The rear passenger fastens or unfastens the seat belt.

### 3. Instructions for safe operation

#### Seat belt pretensioner and load limiter \*



The seat belt pretensioner and load limiter can reduce the pressure of the seat belt on the chest of the driver or passenger and improve the protection performance.

- Before the collision, the seat belt pretensioner and load limiter can restrain the driver or passenger and enable him or her to maintain a correct sitting posture to prevent the body from leaning forward.
- In the event of a severe collision where the triggering condition is reached, the seat belt pretensioner and load limiter will be triggered, driving the seat belt webbing to be quickly retracted and tensioned.

- When a vehicle collision occurs, the human body will move forward, and the seat belt load limiter will be activated at this time, so that the restraint force of the seat belt on the human body will be within a certain range, preventing the occupant from being further injured due to excessive force. And at the same time, the seat belt pretensioner and load limiter will work with the airbag to achieve a better safety protection performance.

#### i NOTE

- When the seat belt pretensioner and load limiter is activated, a little harmless smoke together with a sound will be produced, which is normal.
- The seat belt pretensioner and load limiter cannot be used any more if deployed,  and in this case, the SRS indicator lamp stays on, please go to the GAC Motor authorized shop for repair in time.

#### Fastening the front seat belt

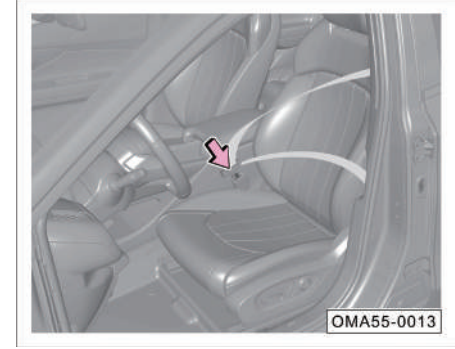

- Keep a correct sitting posture. => See [page 12](#)
- Pull out the seat belt slowly at a uniform speed, insert the lock tongue into the corresponding buckle until a click sound is heard.
- Pull the seat belt and confirm that the lock tongue is properly locked.

#### i NOTE

All seat belts are fastened in the same way, and the driver is responsible for reminding passengers to fasten the seat belts correctly.

### 3. Instructions for safe operation

#### Unfastening the seat belt

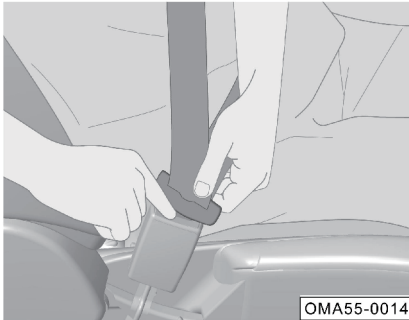

- Press the red button of the buckle. Then the lock tongue will pop out automatically.
- Grasp the seat belt to allow it to retract slowly.

#### Pregnant women must fasten the seat belts correctly



How should a pregnant woman fasten the seat belt?

- Adjust the seat and head restraint to the proper position.
- Grasp the lock tongue, slowly pull the seat belt over the shoulder, and ensure that the lap belt is as low as possible and not pressed against the abdomen.
- Insert the lock tongue into the corresponding buckle until a buckling sound is heard.
- Pull the shoulder belt upward parallel to the upper body, tension the lap belt, and make sure that the lock tongue is properly locked.

#### **WARNING**

To reduce the risk of injury during emergency braking or accidents, please observe the following precautions:

- Before driving, make sure that all occupants have properly fastened the seat belts.
- Each seat belt is for one person only. Do not share a seat belt with other persons (including children).
- Do not recline the front seat back excessively for comfort.
- Do not put the shoulder belt under or behind your arm.
- Do not put the shoulder belt under or behind your arm.
- Be sure to insert the lock tongue into the buckle of corresponding side instead of the buckle of other side.

## 3. Instructions for safe operation

### 3.3 Supplemental restraint system (SRS)

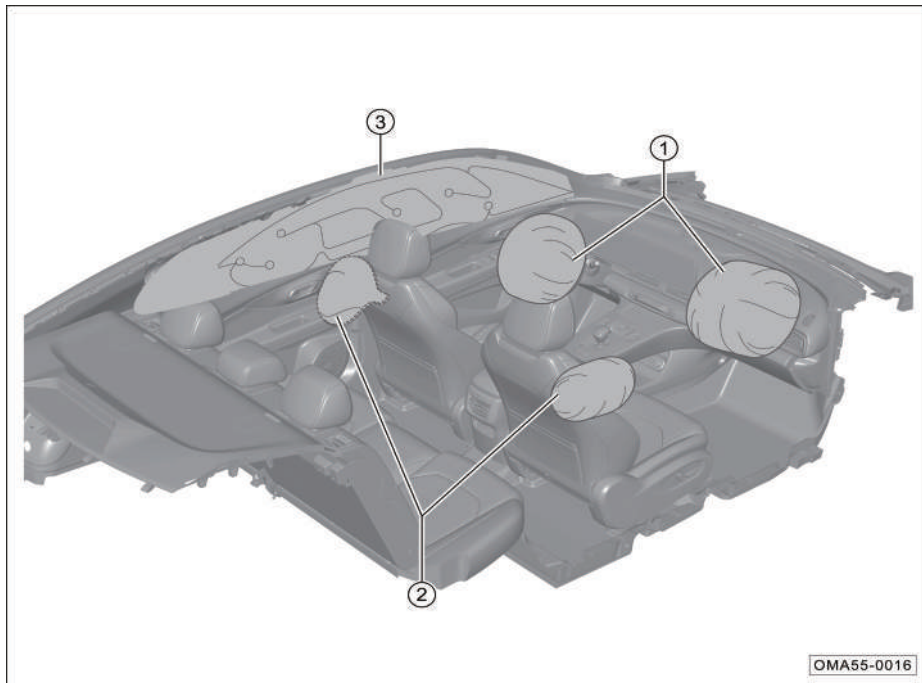

Depending on vehicle configurations, the deployment positions of the SRS are as shown below:

- ① Front seat frontal airbags.
- ② Front seat side airbag\*.
- ③ Side curtain airbag\*.

#### **i** NOTE

The airbag will produce a little harmless smoke when deployed, which is normal.



### 3. Instructions for safe operation

#### Supplemental restraint system (SRS) indicator lamp

With the vehicle power switch set to “ON” position,  the indicator lamp will be on for a few seconds and go out after the system completes self-test.

 A system fault is indicated when the indicator lamp is in the following conditions:

1. The indicator lamp does not come on after the vehicle power switch is set to “ON” position.
2. With the vehicle power switch set to “ON” position, the indicator lamp does not go out after the system completes self-test.
3. After the vehicle power switch is set to “ON” position, the indicator lamp goes out after the self-test, but then comes on again.
4. The indicator lamp comes on or flashes while the vehicle is running.

#### WARNING

- **Never attempt to repair, adjust or modify the airbag.**
- **When the SRS is faulty, please contact the GAC Motor authorized shop for inspection; otherwise, the system will not trigger or abnormally trigger the airbag in the event of a collision.**
- **When the SRS is faulty, please contact the GAC Motor authorized shop for inspection; otherwise the system will not trigger or abnormally trigger the airbag in the event of a collision.**

#### Front seat frontal airbag

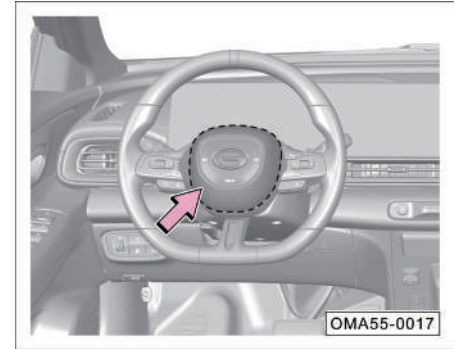

The driver's frontal airbag is installed inside the steering wheel (as indicated by the dotted dash) marked with “AIRBAG”.

### 3. Instructions for safe operation

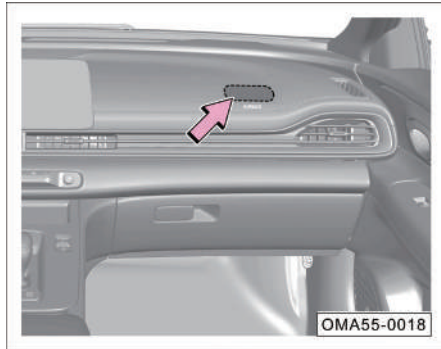

The front passenger's frontal airbag is installed inside the instrument panel (as indicated by the dotted dash) marked with "AIRBAG".

In the event of a severe frontal collision where the triggering condition is met, the frontal airbags will be triggered by the system and deploy rapidly to assist the seat belts in protecting the driver and front passenger.

In certain collision accidents, the system may simultaneously trigger other airbags.

#### **WARNING**

**Do not attach or place any decorative objects on the surface of instrument panel, because when the vehicle is running or the airbag deploys, these objects will fall, be knocked over and roll around in the vehicle, affecting the driver's driving and hurting the passengers in the vehicle.**

The front seat frontal airbags might not be triggered in the following cases:

- The vehicle power switch set to "ACC" or "OFF" position.
- Minor frontal collision.
- Side collision.
- Rear-end collision.
- Rollover.
- Other special circumstances.

#### **NOTE**

The word "minor" refers to the extent with respect to the car SRS controller and has nothing to do with the damage of the car.

### 3. Instructions for safe operation

#### Front seat side airbag\*



The front seat side airbags are installed in the outboard sides of the driver's seat back and the front passenger's seat back respectively (as indicated by the dotted dash) marked with "AIRBAG".

In the event of a severe side collision where the triggering condition is met, the side airbags on the side where the vehicle collides will be triggered by the system and deploy rapidly to assist the seat belts in protecting the driver and front passenger.

In certain collision accidents, the system may simultaneously trigger other airbags.

The front seat side airbags might not be triggered in the following cases:

- The vehicle power switch set to "ACC" or "OFF" position.
- 100% frontal collision.
- Minor side collision.
- Rear-end collision.
- Other special circumstances.

#### **i** NOTE

The word "minor" refers to the extent with respect to the car SRS controller and has nothing to do with the damage of the car.

### 3. Instructions for safe operation



#### WARNING

- **Observe the instructions on the warning label pasted on the side of the door. Do not lean your body against the door side equipped with side airbags during driving.**
- **Do not cover the side airbags with seat covers or other objects; otherwise, the side airbags will not be fully triggered to protect the occupants when an accident occurs.**

#### Side curtain airbag\*

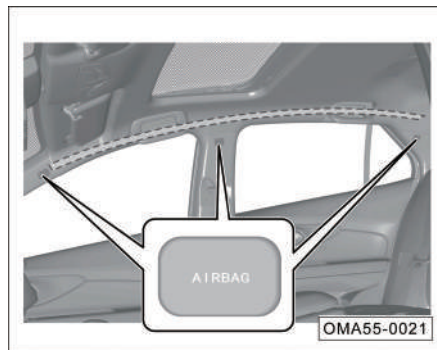

The side curtain airbags are installed in the left and right sides of the roof respectively (as indicated by the dotted dash) marked with "AIRBAG".

In the event of a severe side collision, the side curtain airbags on the side where the vehicle collides will be triggered by the system and deploy rapidly to assist the seat belts in protecting the driver and passengers.

In certain collision accidents, the system may simultaneously trigger other airbags.

The side curtain airbags might not be triggered in the following cases:

- The vehicle power switch set to "ACC" or "OFF" position.
- 100% frontal collision.
- Minor side collision.
- Rear-end collision.
- Other special circumstances.

#### NOTE

The word "minor" refers to the extent with respect to the car SRS controller and has nothing to do with the damage of the car.

### 3. Instructions for safe operation

#### 3.3.1 Cases where the airbags may deploy

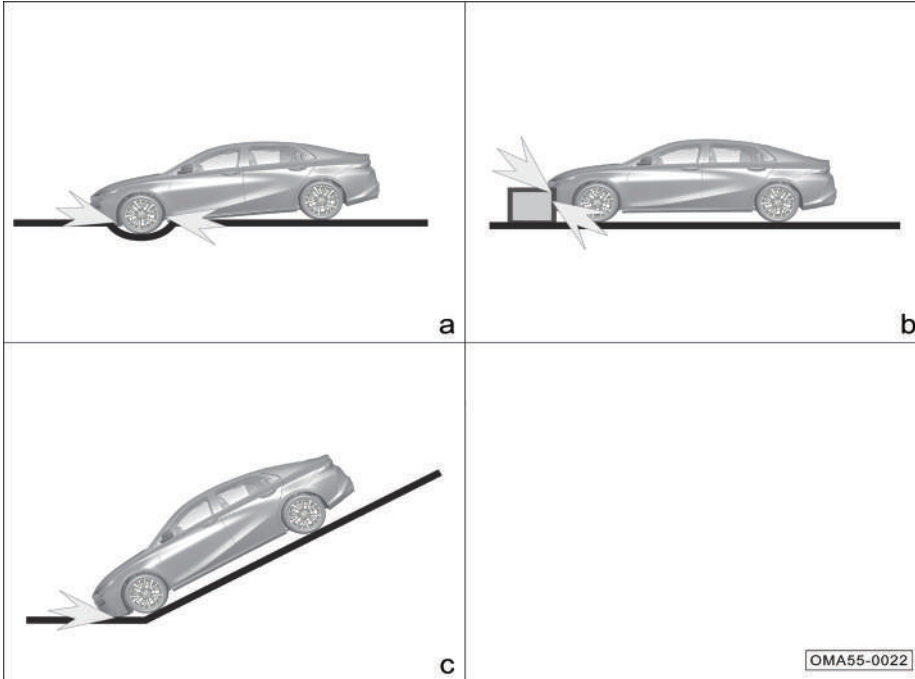

- Nose-down to the ground when the vehicle crosses a deep groove.
- Collision with roadside protrusions, curbs, etc.
- Nose-down to the ground when the vehicle runs down a steep slope.

### 3. Instructions for safe operation

#### 3.3.2 Cases where the airbags might not deploy

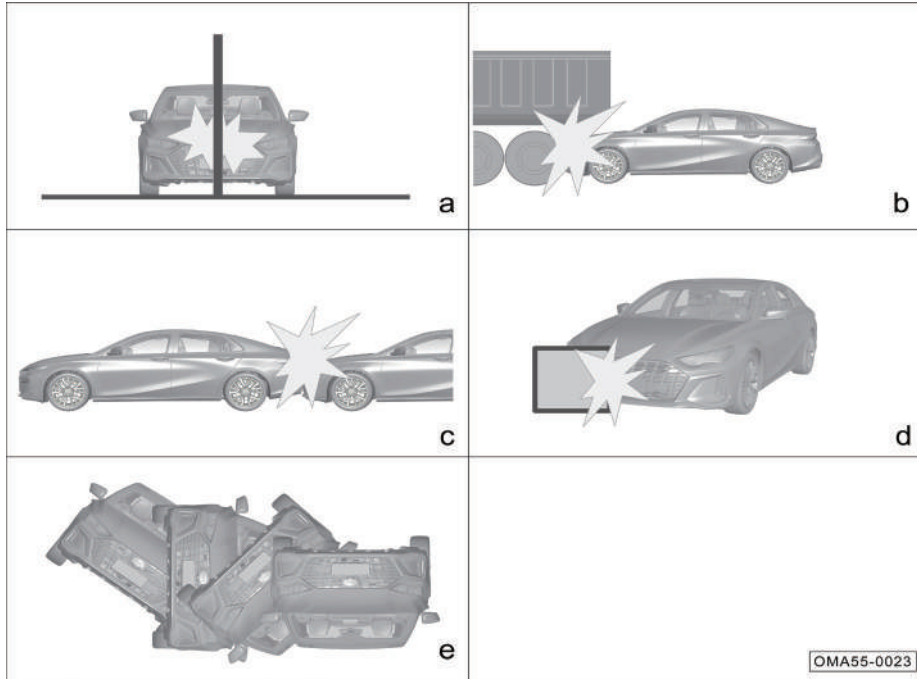

- a. Collision with concrete pillars, trees or other elongated objects.
- b. Rear-end collision with the lower rear end of large truck.
- c. Rear-end collision by other vehicles.
- d. Collision with a wall or another vehicle, other than frontal collision.
- e. Rollover or tilting.

### 3.4 Child restraint

#### 3.4.1 General description

The child must sit in a rear seat, and a suitable child safety seat should be selected according to the body size of the child.



Warning labels are pasted on the front and back of the right sun visor to remind the front passenger of the danger of frontal airbag. Be sure to read and follow the instructions on the labels.

#### WARNING

- Do not install any rear-facing child safety seats on seats with frontal airbags!
- Even if the child has been put in a child safety seat, do not let its head or any other part of the body rest on the door area (the deployment area of the front seat side airbag or side curtain airbag); otherwise the impact force of the deployed front seat side airbag or side curtain airbag can cause serious injury or even death of the child.
- Do not let children stand or kneel on the seat.
- Do not allow children to operate devices that may cause pinch to themselves (such as power window, sunroof\*, etc.).

#### WARNING

- Never leave children alone in the vehicle!
- Never hold infants or toddlers on your knees!
- Seat belts are not suitable for infants and toddlers as they can cause injuries in the event of an accident.
- Ensure that in the event of a collision or emergency braking, children are less likely to be injured by hitting any hard objects in the vehicle.
- Lock the child safety lock of the door on the side where the child sits.

### 3. Instructions for safe operation

#### 3.4.2 Child safety seat

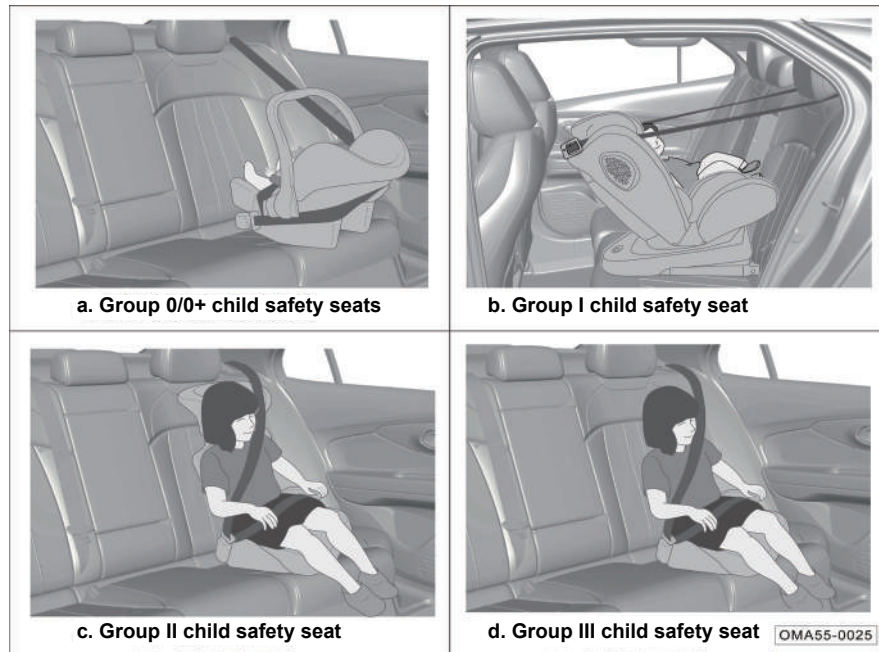

**Classification of child safety seats (for reference only):**

- a. Group 0/0+ child safety seat:**
  - Suitable for infants weighing less than 13 kg.
  
- b. Group I child safety seat:**
  - Suitable for toddlers weighing between 9kg and 18kg. For children weighing up to 18 kg (3 years old), rear-facing child safety seats must be installed.
  
- c. Group II child safety seat:**
  - Suitable for children weighing between 15 kg and 25 kg.
  
- d. Group III child safety seat:**
  - Suitable for children weighing between 22kg and 36kg.



Welldon Angela 2nd Generation is recommended for Group I child safety seat, and the product model is WD002-ZJC.

Precautions for installation:

- Adjustment of seat body: Rear-facing seat is recommended. Adjust the seat body to the most reclined (nearly horizontal) state.
- Adjustment of headrest: It is recommended that the headrest of the child safety seat be flush with the shoulder of the child.
- It is recommended that the top tether hook be fixed to the rear coat rack interface of the vehicle.
- It is recommended to take the path of top tether around both sides of the child safety seat headrest.
- It is recommended that clip gasket and shoulder belt jacket be used.

### 3. Instructions for safe operation

---

#### 3.4.3 Information about child safety seat

Information about the applicability of different seating positions for child restraint systems:

Weight group	Mounting position		
	Front passenger's seat	Outboard rear seats	Center rear seat
Group 0: <10 kg	X	U	X
Group 0+: <13 kg	X	U	X
Group I: 9~18 kg	X	U/UF/L	X
Group II: 15~25 kg	X	UF	X
Group III: 22~36 kg	X	UF	X

Note: The uppercase letters in the table are defined as follows:

**U=** The “general” child restraint systems approved for this weight group are suitable.

**UF=** The forward-facing “general” child restraint systems approved for this weight group are suitable.

**L=** The listed special child restraint systems are suitable, which may be for special vehicles, or of restricted or semi-general categories.

**X=** The child restraint systems approved for this weight group are not suitable.

For some child safety seats, a size class is specified. Be sure to check the size class according to the manufacturer’s instructions, packaging, and child safety seat label. For guidance on proper installation, please refer to the instruction of the child safety seat.

### 3. Instructions for safe operation

#### ISOFIX mounting positions for ISOFIX child safety seats

Weight group	Size class	Fixture module	Mounting position		
			Front passenger's seat	Outboard rear seats	Center rear seat
Carry-cot	F	ISO/L1	X	X	X
Group 0: <10 kg	G	ISO/L2	X	X	X
	E	ISO/R1	X	IL	X
Group 0+: <13 kg	E	ISO/R1	X	IL	X
	D	ISO/R2	X	IL	X
	C	ISO/R3	X	IL	X
Group I: 9~18 kg	D	ISO/R2	X	IL	X
	C	ISO/R3	X	IL	X
	B	ISO/F2	X	IUF	X
	B1	ISO/F2X	X	IL	X
	A	ISO/F3	X	IUF	X
Group II: 15~25 kg	-	-	X	IUF	X
Group III: 22~36 kg	-	-	X	IUF	X

Note: The uppercase letters in the table are defined as follows:

**IUF** - The “forward-facing” general ISOFIX child safety seats for this weight group that are fixed with top tether are suitable.

**IL** - The listed special ISOFIX child restraint systems are suitable, which may be for special vehicles, or of restricted or semi-general categories.

**X** - The child safety seats for this weight group are not suitable.

For some child safety seats, a size class is specified. Be sure to check the size class according to the manufacturer’s instructions, packaging, and child safety seat label. For guidance on proper installation, please refer to the instruction of the child safety seat.

### 3. Instructions for safe operation

#### 3.4.4 Correct installation of child safety seat

The child safety seat is installed by three-point seat belt, ISOFIX system, or LATCH system.

To ensure a better protection effect and prevent the headrest from affecting the performance of the child safety seat during use, it is recommended to remove the headrest of the seat on which the child safety seat is installed.

#### **i** NOTE

During the actual installation of the child safety seat, be sure to refer to the instruction of the child safety seat for correct installation.

#### Installation of child safety seat by three-point seat belt



1. Place the child safety seat on the rear seat.
2. Pass the seat belt through the child safety seat and fully insert the tongue into the buckle until a click sound is heard.

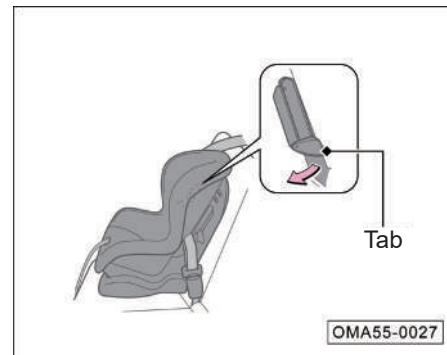

3. Push the tongue down and pass the shoulder belt through the slit on the side of the child safety seat.

### 3. Instructions for safe operation

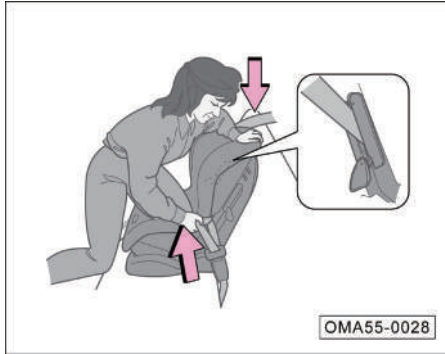

4. Grasp the shoulder belt near the buckle and pull it up to tension the lap belt. At this time, press the child safety seat with your own weight and push it into the vehicle seat.

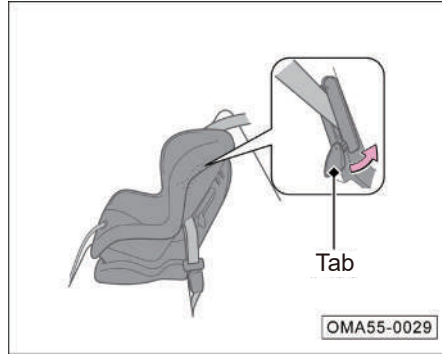

5. Place the seat belt correctly and push the tab up. Make sure the seat belt is not twisted. When pushing the tab up, pull upward the upper part of the shoulder belt to tension the belt.

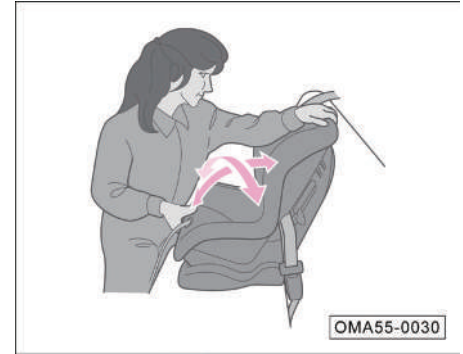

6. Shake the child safety seat back and forth, left and right to make sure it is firmly fixed.
7. Make sure that all unused seat belts in the reach of the children are locked.

### 3. Instructions for safe operation

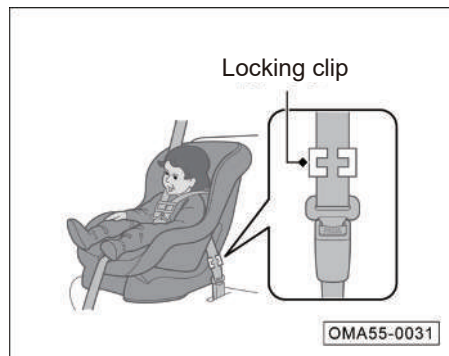

If no means are provided on the child safety seat for securing the seat belt, please install a locking clip on the seat belt.

- After the above steps 1 and 2, pull up the shoulder belt and make sure the lap belt is tensioned.
- Firmly grasp the seat belt near the tongue. Pinch the two parts of the seat belt together so that they do not slip out of the tongue. Unbuckle the seat belt.

Install the locking clip as shown. Place the buckle as close as possible to the locking tab and insert the locking tab into the locking clip. Go to steps 6 and 7.

#### Installing ISOFIX System

The rear seats of this vehicle are equipped with the LATCH system, and thus suitable for the LATCH or ISOFIX child safety seats. The installation instructions of the LATCH child safety seat are as follows.

#### ⚠ WARNING

- **The child safety seat anchorages installed in this vehicle can be used to fix the child safety seats only.**
- **Do not connect straps, hard and sharp objects or any other objects other than child safety seats to the anchorages; otherwise children may be endangered in the event of an accident.**

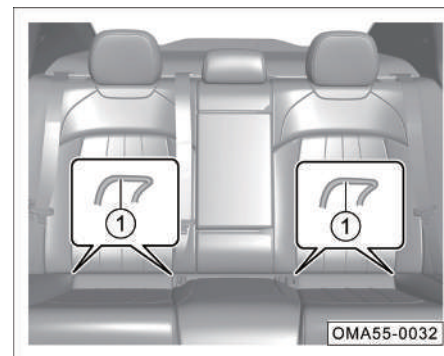

#### i NOTE

The front anchorage ① of the rear seat is hidden in the gap between the seat back and cushion.

### 3. Instructions for safe operation

The installation instructions of the LATCH child safety seat are as follows.

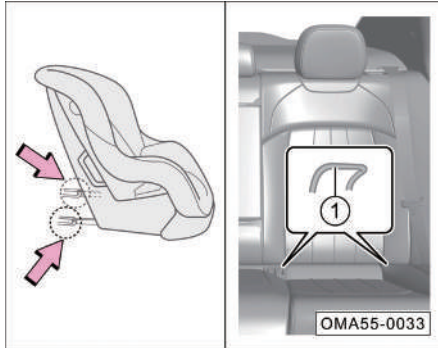

1. Put the child safety seat on the seat, find the front anchorage ①, and insert the lower guide groove of the child safety seat as arrowed into the front anchorage ① until a click sound is heard.

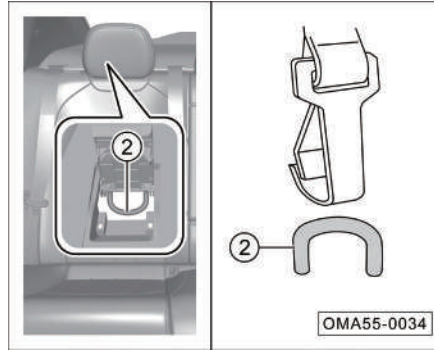

2. Let the strap through the headrest pillar, open the protective cover of the upper anchorage ②, and attach the strap hook to the rear anchorage ② with the strap is not twisted.
3. Tension the strap and shake the child safety seat to ensure it is firmly fixed.

#### i NOTE

- If the rear-facing child safety seat is used, the headrest shall be adjusted to the lowest position.
- seat back, remove the headrest. seat back, remove the headrest.
- If a booster cushion is used, the top of the headrest should be adjusted to be flush with or closest to the top of the child's head.

## 3. Instructions for safe operation

---

### 3.5 Exhaust gas hazard

#### Carbon monoxide

The exhaust gas emitted by the engine contains the toxic carbon monoxide gas. Please use the vehicle correctly to prevent the carbon monoxide gas from entering the vehicle.

Please contact the GAC Motor authorized shop to check whether the exhaust system is normal in the following cases:

- The exhaust system makes abnormal noises.
- The exhaust color is abnormal.

If the engine is idling during parking, please open all the windows and turn on the A/C system:

1. Select the fresh air mode.
2. Select  mode.
3. Set the fan speed to the maximum.



#### WARNING

- **Carbon monoxide is toxic, and inhaling a great quantity of it will cause loss of consciousness and even death.**
- **When the engine is started for a long time in a confined space (such as a garage, etc.), carbon monoxide will quickly accumulate, resulting in excessive carbon monoxide in the vehicle. After starting the engine, drive the vehicle away from the confined space immediately.**



### 3.6 Safety label

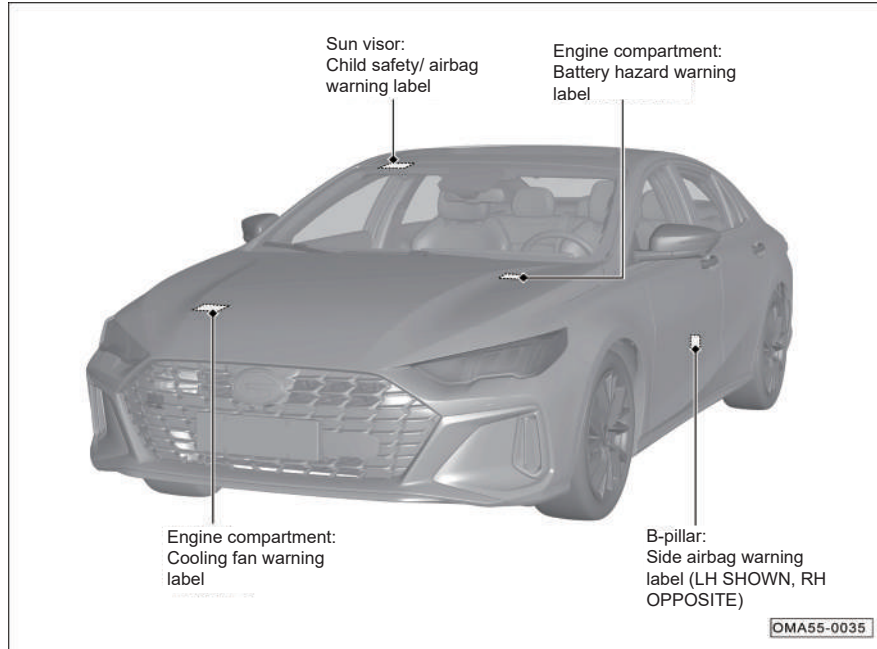

The labels are located as shown to remind you of the potential danger that can cause serious injury or death. Please read these labels carefully.

If the label comes off or is difficult to read, please go to the GAC Motor authorized shop in time for replacement.

#### **i** NOTE

In case of any discrepancy in the illustrated location or quantity of the labels, the actual vehicle shall prevail.

## 4. Operation of systems and equipment

### 4.1 Cab

#### 4.1.1 Steering wheel

##### Adjustment of the steering wheel position



- Adjust the driver's seat until your chest is at least 25mm away from the steering wheel.

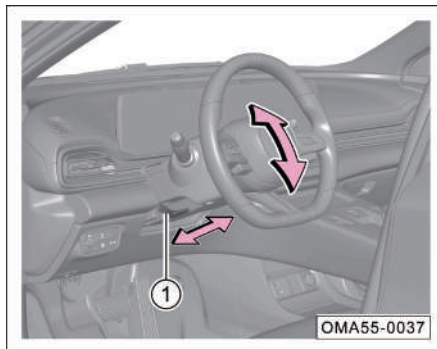

- Push down the locking handle ① to unlock the steering wheel.
- Adjust the steering wheel to the appropriate position up, down, front, and back as required, so that you can see the instrument panel and all indicator lamps.
- Pull up the locking handle ① to lock the steering wheel and make sure it is firmly locked.

#### CAUTION

If a great locking force is applied for locking the locking handle, you can release the locking handle again and then shake it up and down for locking again.

#### WARNING

- During driving, the driver's hands should always grasp the outer ring of the steering wheel (9 o'clock and 3 o'clock positions).
- After adjustment, the steering wheel must be locked to prevent shifting while the vehicle is running.
- Only when the vehicle is stopped can the steering wheel be adjusted to avoid traffic accidents.
- To ensure safety, the steering wheel should face your chest, otherwise the airbag cannot provide effective protection in the event of an accident.

### Buttons on steering wheel

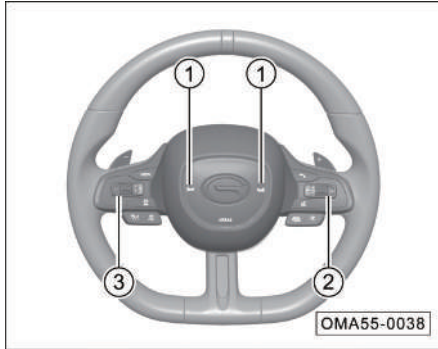

- ① Horn button: Press  button to sound the horn; release the button to stop sounding the horn.

#### WARNING

Do not press and hold  button for a long time; otherwise, the horn is highly prone to be damaged.

- ② AV system control button => See page 138
- Voice button => See page 138
  - Custom button\* => See page 139
  - Exhaust sound button\* => See page 188
- ③ The left buttons include the control buttons of the instrument cluster display and the cruise control buttons:
- Control buttons of the instrument cluster display:
    - Theme setting of instrument panel => See page 48
    - Driving information => See page 47
    - Menu setting => See page 49
    - Alarm message => See page 52
  - Cruise control button:
    - Cruise control buttons\* => See page 200
    - ACC button\* => See page 202

## 4. Operation of systems and equipment

### 4.1.2 Instrument cluster

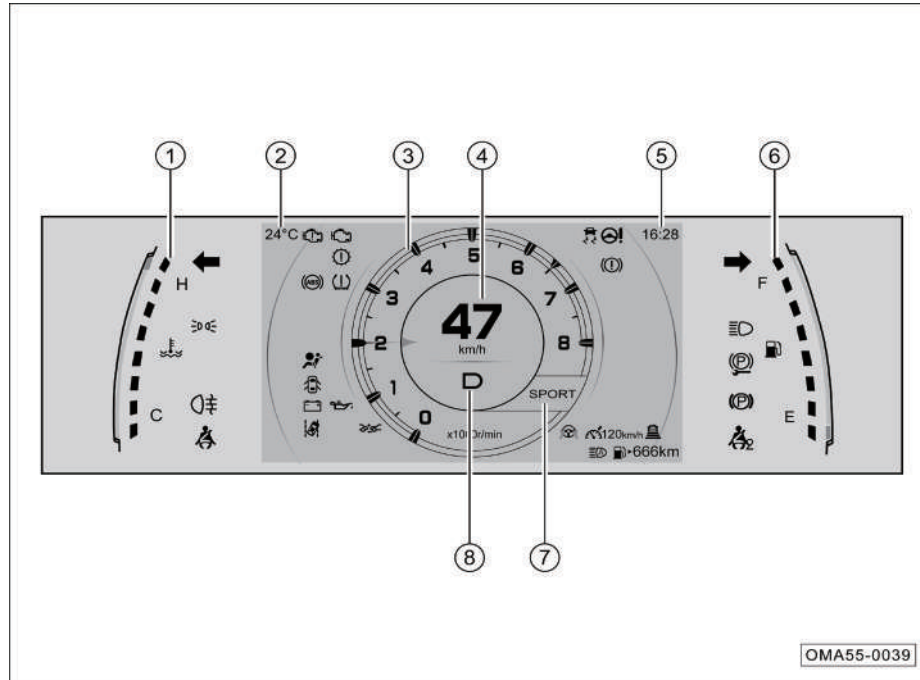

#### Instrument cluster with 7-inch TFT display - sport theme (I)\*

- ① Engine coolant temperature gauge
- ② Outside temperature indication
- ③ Tachometer
- ④ Speedometer
- ⑤ Time display
- ⑥ Fuel gauge
- ⑦ Driving mode
- ⑧ Gear display

## 4. Operation of systems and equipment

### Instrument cluster with 7-inch TFT display - sport theme (II)\*

- ① Engine coolant temperature gauge
- ② Outside temperature indication
- ③ Instrument cluster display
- ④ Tachometer
- ⑤ Speedometer
- ⑥ Time display
- ⑦ Fuel gauge
- ⑧ Driving mode
- ⑨ Gear display

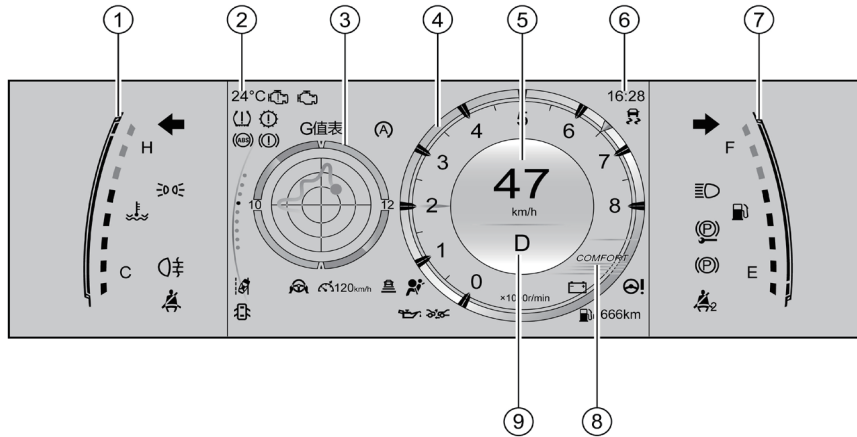

OMA55-0260

## 4. Operation of systems and equipment

### Instrument cluster with 7-inch TFT display - full screen theme\*

- ① Engine coolant temperature gauge
- ② Outside temperature indication
- ③ Tachometer
- ④ Instrument cluster display
- ⑤ Speedometer
- ⑥ Time display
- ⑦ Fuel gauge
- ⑧ Gear display
- ⑨ Driving mode

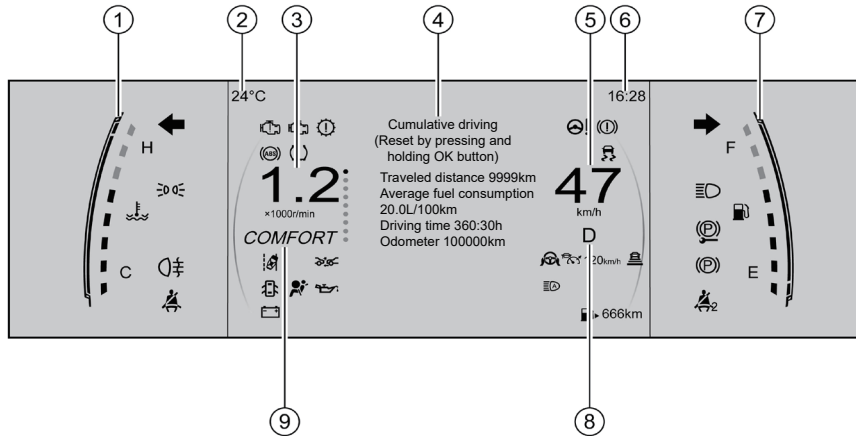

OMA55-0261

## 4. Operation of systems and equipment

### Instrument cluster with 7-inch TFT display - sport + theme\*

- ① Engine coolant temperature gauge
- ② Outside temperature indication
- ③ Tachometer
- ④ Speedometer
- ⑤ Time display
- ⑥ Fuel gauge
- ⑦ Gear display
- ⑧ Driving mode

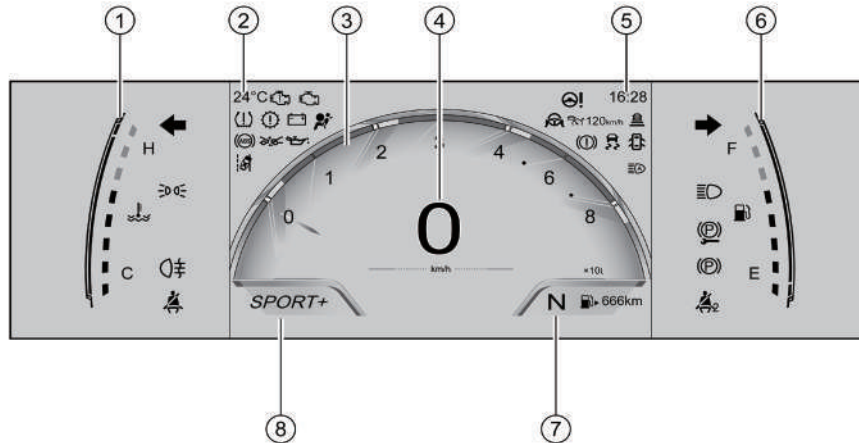

OMA55-0262

## 4. Operation of systems and equipment

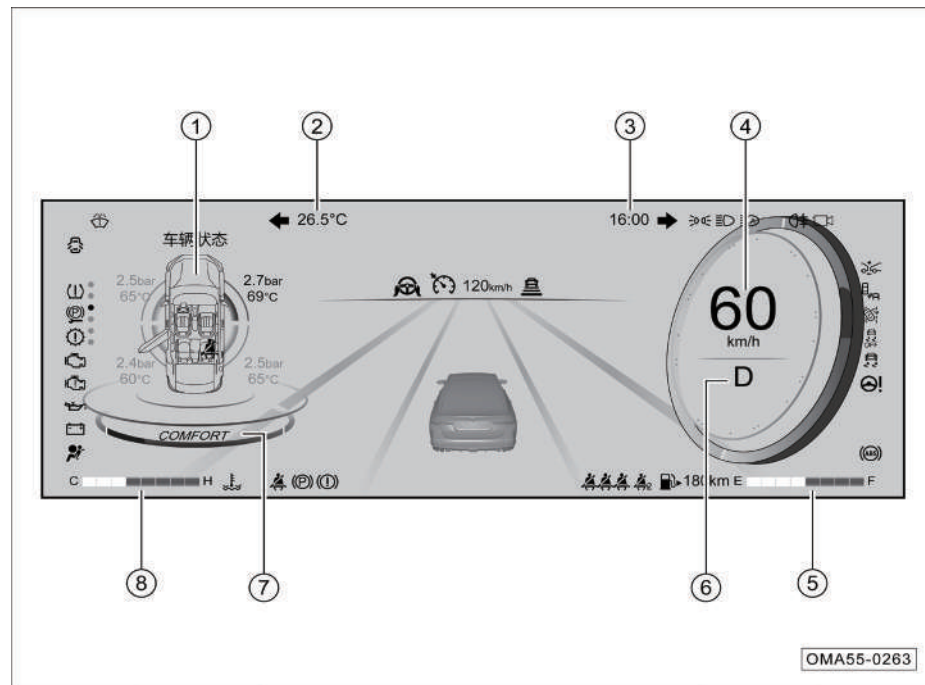

### 10.25-inch instrument cluster - high-tech theme\*

- ① Instrument cluster display
- ② Outside temperature indication
- ③ Time display
- ④ Speedometer
- ⑤ Fuel gauge
- ⑥ Gear display
- ⑦ Driving mode
- ⑧ Engine coolant temperature gauge



## 4. Operation of systems and equipment

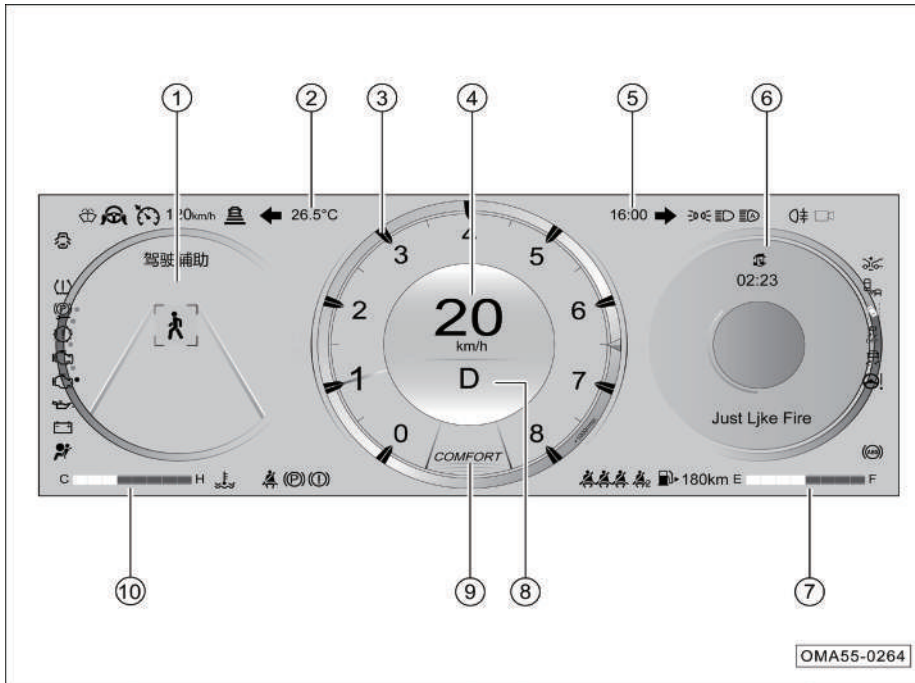

### 10.25-inch instrument cluster - organic theme\*

- ① Instrument cluster display
- ② Outside temperature indication
- ③ Tachometer
- ④ Speedometer
- ⑤ Time display
- ⑥ Entertainment information
- ⑦ Fuel gauge
- ⑧ Gear display
- ⑨ Driving mode
- ⑩ Engine coolant temperature gauge

## 4. Operation of systems and equipment

### 10.25-inch instrument cluster - full map theme\*

- ① Instrument cluster display
- ② Outside temperature indication
- ③ Time display
- ④ Fuel gauge
- ⑤ Speedometer
- ⑥ Gear display
- ⑦ Driving mode
- ⑧ Engine coolant temperature gauge
- ⑨ Tachometer



OMA55-0265

## 4. Operation of systems and equipment

### 10.25-inch instrument cluster - sport + theme\*

- ① Engine coolant temperature gauge
- ② Outside temperature indication
- ③ Tachometer
- ④ Speedometer
- ⑤ Time display
- ⑥ Fuel gauge
- ⑦ Gear display
- ⑧ Instrument cluster display
- ⑨ Driving mode

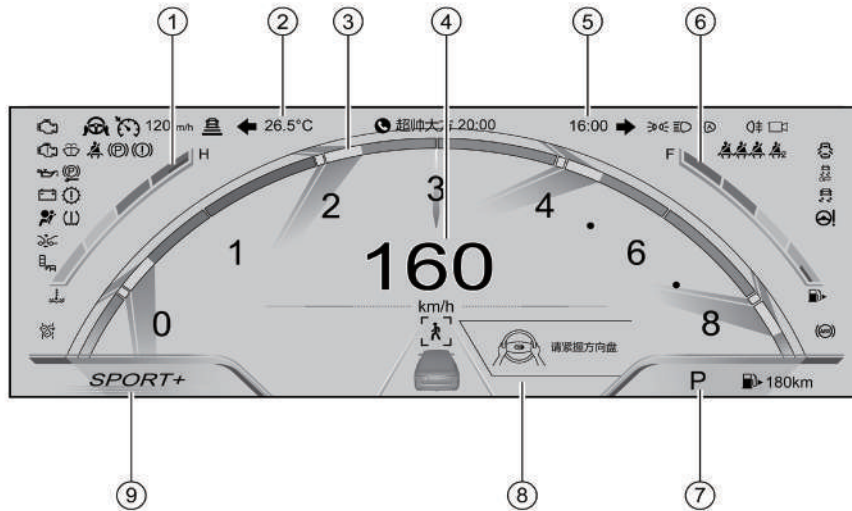

OMA55-0266

## 4. Operation of systems and equipment

### Tachometer

The tachometer is used to indicate the current engine speed, in 1,000 r/min.

#### NOTE

6000~8000 r/min is the high load area of the engine, which shall never be reached for fear of engine damage.

### Instrument cluster display

The displayed information includes: Driving information => See page 47, menu setting => See page 49, G-force meter => See page 50, timer => See page 50, vehicle status => See page 51, energy consumption trend graph => See page 51, navigation information \* => See page 51, ADAS \* => See page 52, alarm message => See page 52, AV and entertainment information => See page 54

#### CAUTION

If the instrument cluster display is abnormal, stop the vehicle immediately for the sake of safety, and contact the GAC Motor authorized shop for inspection.

### Engine coolant temperature gauge

The engine coolant temperature gauge is used to indicate the current temperature of the engine coolant.

- The indication range covers C~H, where, "C" means low temperature and "H" means high temperature.
- After the engine is started, the corresponding scale divisions of the coolant temperature gauge will be illuminated according to different temperatures, and the engine operating temperature will vary depending on the ambient temperature and engine load.
- Conditions where the gauge indicates high coolant temperature: prolonged climbing in hot weather; deceleration or stop after driving at a high speed; in areas with heavy traffic, where the HVAC system is turned on and the engine idles for a long time; towing, etc.
- Conditions where the gauge indicates low coolant temperature: insufficient warm-up after cold start in cold weather; running with maximum heating in cold weather, etc.

### Driving mode

- The current driving mode of the vehicle is displayed according to the received signal.

### Speedometer

The speedometer displays the current speed of the vehicle in km/h.

#### CAUTION

For driving safety, please strictly abide by the traffic rules, and do not speed the vehicle at will.

### Fuel gauge

The fuel gauge is used to indicate the current amount of fuel remaining in the fuel tank.

- The indication range is E~F, where "E" means the fuel tank is empty, and "F" means the fuel tank is full.
- The corresponding scale divisions will be illuminated according to the amount of remaining fuel in the fuel tank. When no scale division or only the first scale division is illuminated, it means that the fuel in the fuel tank is insufficient, and the indicator lamp  on the instrument cluster will flash in yellow to remind the driver of low fuel level and to refuel as soon as possible.

## 4. Operation of systems and equipment

### Range

- The fixed position of the range is usually displayed in the lower right corner of the screen, and the indicated icon is the fuel indicator lamp.
- When the range is less than 50km or the fuel level is less than 10%, the range will display “Low”, and the pop-up text at the top also reminds the user to refuel in time.

### Gear display

- The current gear information of the vehicle such as “P”, “R”, “N” or “D” is displayed according to the received signal. For models with paddle shifter, the digital gear in the lower right corner of D can be displayed for a short time when the paddle shifter is toggled.

### Odometer

- The indication range is 0 km ~ 999999km.

### Driving information (7-inch instrument cluster)

When the vehicle power switch is set to “ON” position, move up or down the “OK” button on the left of the steering wheel to switch the display information interface.

- The driving information screen displays: Current driving, cumulative driving, odometer and vehicle state.

### Current driving...

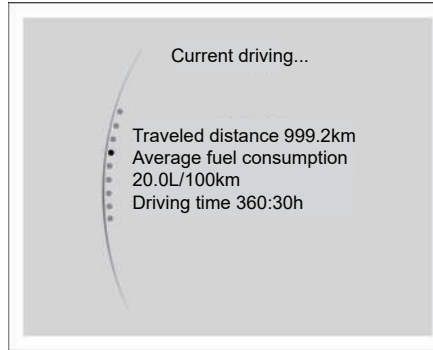

Current trip: It indicates the driving information (trip distance/average fuel consumption/driving time) of the vehicle in a single trip after the vehicle power switch is set to “ON” position, and the single ignition cycle will be reset.

### Cumulative driving

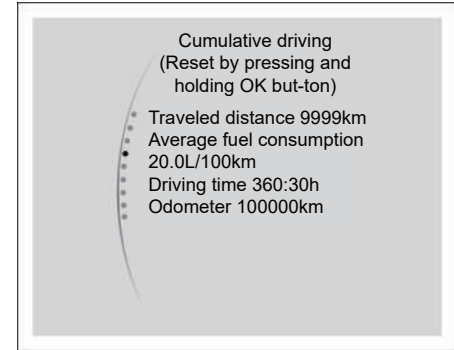

Cumulative driving: It indicates the driving information (cumulative distance/ average fuel consumption/ driving time) of the vehicle since the last reset, which can be reset by pressing and holding “OK” button. The odometer information is displayed on this interface and cannot be reset.

## 4. Operation of systems and equipment

### Driving information (10.25 inch instrument cluster)

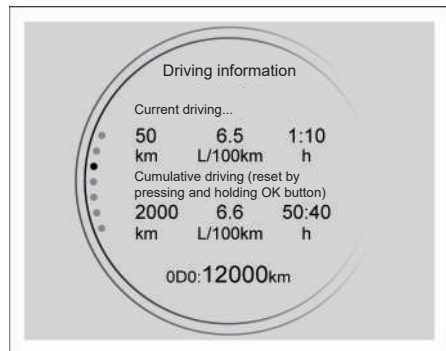

When the vehicle power switch is set to “ON” position, move up or down the “OK” button on the left of the steering wheel to switch to the driving information interface.

- On the driving information screen, the current trip information, cumulative driving information and odometer information are displayed.
- Current trip: It indicates the driving information (including the trip distance, the average fuel consumption and the driving time) of the vehicle in a single trip after the vehicle power switch is set to “ON” position. This parameter cannot be reset.

- Cumulative driving: It indicates the driving information (including the cumulative distance, the average fuel consumption and the driving time) of the vehicle since the last reset, which can be reset by pressing and holding “OK” button.
- Odometer: It indicates the mileage of the vehicle, which cannot be reset.

### Theme setting of instrument panel

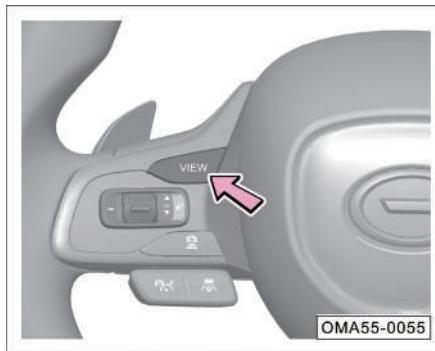

With vehicle power switch set to “ON” position, press “VIEW” button on the left of steering wheel to access the screen of theme setting of instrument panel.

- Press the “VIEW” button to enable the 7-inch instrument cluster to cycle through “Sport theme, Full screen theme, Sport + theme”.
- Press the “VIEW” button to enable the 10.25-inch instrument cluster to cycle through “Intelligent driving theme, Organic theme, Navigation theme, Sport + theme”.

### **i** NOTE

The theme of the instrument cluster can also be changed by changing the driving mode bound with the themes through the center console.

## 4. Operation of systems and equipment

### Menu setting



With the vehicle power switch set to “ON” position, when the vehicle speed is zero, perform following function setting via “System Settings → Screen Display → Instrument Cluster Display” in the AV2T:

#### 1. Instrument volume

- You can select “Low”, “Medium”, and “High” for the instrument sound. The default mode is “Medium”.

#### 2. Language setting

- You can select “Chinese” or “English”. The default display language is “Chinese”.

#### 3. Unit of fuel consumption/mileage

- Users can choose km, L/100km or km, km/L or mpg (Imperial units), mi or mpg (US units), mi as the unit of fuel consumption/mileage according to their personal habits. The default is km, L/100 km.

#### 4. Unit of measurement of temperature

- Users can choose two temperature unit display modes of Celsius temperature “°C” or Fahrenheit temperature “°F” according to their personal habits. The default is °C.

#### 5. Unit of measurement of pressure

- Users can select three pressure unit display modes (kPa, bar and psi) according to personal habits. The default mode is kPa.

#### 6. Backlight of instrument panel

- Users can choose different levels of backlight from 1 to 8 according to their personal habits, with default level 4.

#### 7. Rear seat belt reminder

- If this function is activated, the rear passengers will be reminded if they do not fasten their seat belts.

#### 8. Reset maintenance reminder

- Click the “Reset” button to reset the maintenance reminder mileage.

#### 9. Maintenance reminder intervals

- Users can set the maintenance reminder intervals according to their personal needs, including 5000km, 7500km, 10000km, etc.

#### 10. Default setting

- Click the “Restore” button, and all the instrument display settings will be restored to their default values.

### **i** NOTE

The 10.25-inch instrument cluster is only taken as an example of menu setting, and the menu setting of the 7-inch instrument cluster is similar. The specific functions and interfaces depend on the actual vehicle configuration.

## 4. Operation of systems and equipment

### i NOTE

- If menu setting is carried out when the vehicle speed is not zero, the alarm message “Safe driving tip: setting needs to be performed when the vehicle stops” will be displayed; if the alarm message is displayed for more than 5s, the instrument cluster will automatically switch to the driving information screen.
- In case of any discrepancy in the menu setting, the actual vehicle configuration shall prevail.

G-force meter

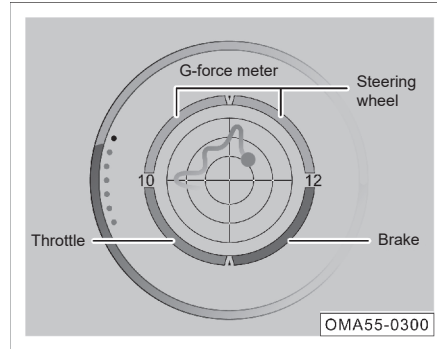

- The G-force meter reflects the acceleration state of the vehicle, and the red dot in the middle simulates the driver's posture in the vehicle.
- The four circles next to the G-force meter represent the steering wheel angle, throttle opening, and brake degree.

Timer



- The timer can be activated with the custom button. The timer function can be activated via the steering wheel custom button when the custom button is set to perform the function of the timer through the center console.



## 4. Operation of systems and equipment

### Vehicle state

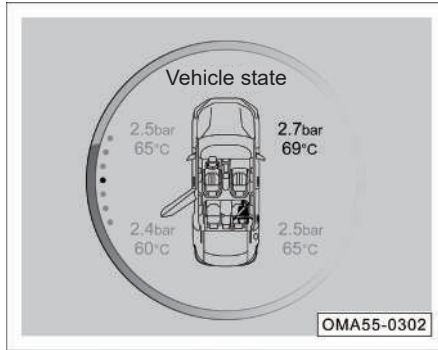

- Vehicle status: It contains the tire temperature, the tire pressure, the status of door, engine hood and trunk, as well as seat belt alarm message. This screen will pop up automatically when there is an exception.

### Energy consumption trend graph

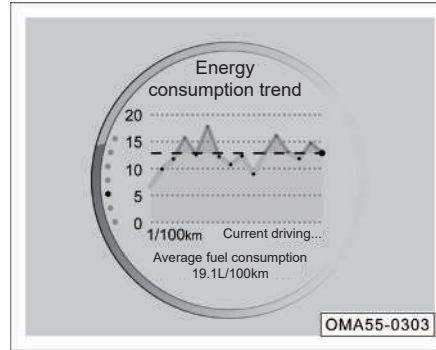

- Energy consumption trend graph reflects the fuel consumption information of the last 50km. The update is performed every 1km, and the average fuel consumption of this screen reflects the average fuel consumption of the last 50km.

### Navigation information \*

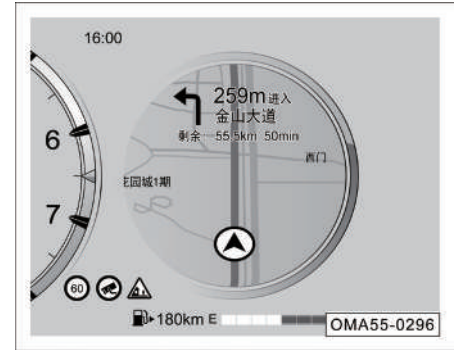

- The navigation information can be synchronized to the instrument cluster display after the AV system navigation function is enabled.

### i NOTE

The organic theme of instrument cluster with 10.25-inch display is illustrated here and for reference only. Please refer to the actual vehicle.

## 4. Operation of systems and equipment

### ADAS\*



- When ADAS function is activated, the corresponding ADAS information, including subject vehicle, left and right lane markings, is displayed. When the forward vehicle is detected, the forward vehicle and the time gap information can be displayed.

### i NOTE

- The ACC, FCM, LKA and ICA information are displayed on this screen.
- Only the technology theme of 10.25-inch meters supports the displaying of the left and right lane marking information.

### Alarm message

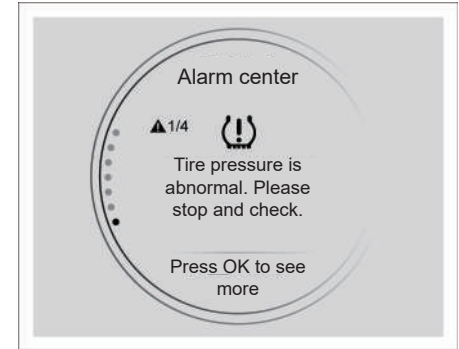

The alarm center is used to save the alarm message. On the alarm message screen, the current state of the vehicle is displayed in the form of texts, pictures, beep sound or others. The driver should always pay attention to checking for alarm message.

- If the vehicle is in normal condition, the alarm center will not be displayed.
- If the vehicle is faulty or certain function is activated/deactivated, corresponding text or picture message will appear at the upper part of the screen of the instrument cluster, reminding the driver about the current state of the vehicle.

## 4. Operation of systems and equipment

- If any alarm message appears, press "OK" button on the left of the steering wheel to confirm the message. Some messages will be stored in the alarm center. If there is no operation after 5 s, the alarm message will be displayed again.

### i NOTE

- The organic theme of 10.25-inch instrument cluster is illustrated here and for reference only. Please refer to the actual vehicle.
- When multiple alarm messages exist, the alarm messages on the instrument cluster display must be read one by one. After confirmation, the OK button of the steering wheel can be used to operate other functions.

### Call information

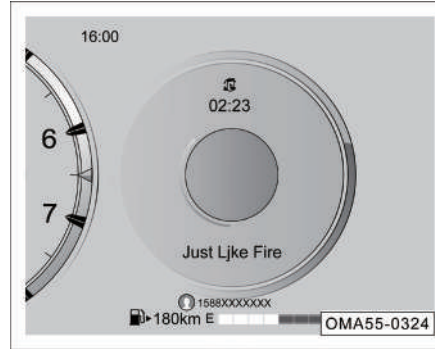

- When the AV system is connected to the Bluetooth of the mobile phone and there is an incoming call, the call information will be displayed at the lower of the instrument cluster display.
- When B-CALL\* or E-CALL\* is used, B-CALL\* or E-CALL\* state will be displayed on the call information screen.

### i NOTE

The organic theme of instrument cluster with 10.25-inch display is illustrated here and for reference only. Please refer to the actual vehicle.

## 4. Operation of systems and equipment

### AV and entertainment information

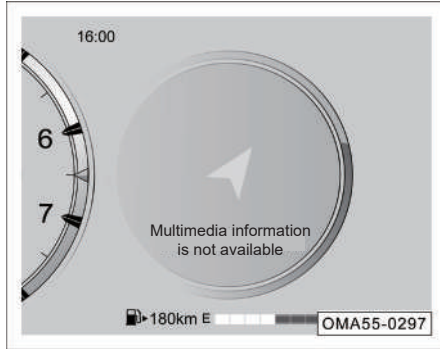

- When the vehicle power switch is set to “ON” position, press the button on the right side of the steering wheel to switch to the AV and entertainment information screen. When the AV system is not turned on, the prompt message “Multimedia information is not available” is displayed on the AV and entertainment information screen.

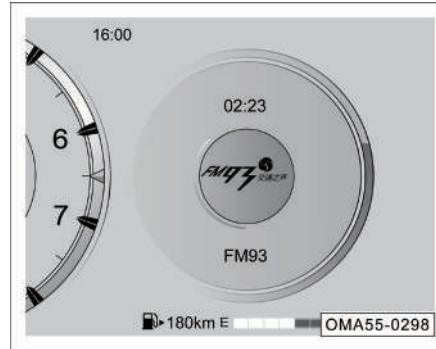









- When the AV system is turned on, the current playback information will be displayed on the AV and entertainment information screen.

### i NOTE









When the AV system activates the CarLife/CarPlay, the AV and entertainment information screen will display the CarLife/CarPlay connection status rather than entertainment functions.

## 4. Operation of systems and equipment













### 4.1.3 Indicator lamp

No.	Icon	Designation	Color	Function
1		Charging system warning lamp	Red	This warning lamp will come on when the engine is not started with the vehicle power switch set to "ON" position, and will go out after the engine is started.
				If this warning lamp comes on after the engine is started, it indicates that the charging system is faulty.
2		Low oil pressure warning lamp	Red	This warning lamp will come on when the engine is not started with the vehicle power switch set to "ON" position, and will go out after the engine is started.
				If this warning lamp comes on after the engine is started, it indicates that the engine oil pressure is low.
3		Malfunction indicator lamp	Yellow	If there is no fault, this indicator lamp will come on and stay on for a few seconds when the engine is not started with the vehicle power switch set to "ON" position, and then will go out after the system self-test.
				If this indicator lamp comes on after the engine is started, it indicates that the engine system is faulty.
4		Emission fault indicator lamp	Yellow	This indicator lamp will come on when the engine is not started with the vehicle power switch set to "ON" position, and will go out after the engine is started.
				If this indicator lamp comes on after the engine is started, it indicates that the exhaust system is faulty.
5		High engine coolant temperature indicator lamp	Red	If the red indicator lamp comes on, it indicates that the engine coolant temperature is too high.
6		Supplemental restraint system (SRS) indicator lamp	Red	If the red indicator lamp comes on, it indicates that the SRS system is faulty.
7		Low fuel level indicator lamp	Yellow	If the yellow indicator lamp flashes, it indicates that the fuel level of the fuel tank is low.
				If the yellow indicator lamp comes on, it indicates that the fuel pump may be faulty.
8		LDW status indicator lamp*	White	If the white indicator lamp comes on, it indicates that the LKA system is activated.
			Red	If the red indicator lamp comes on, it indicates that the LKA is faulty. In that case, please go to the GAC Motor authorized shop for inspection in time.
			Green	If the green indicator lamp comes on, it indicates that the LKA is working normally or intervenes with the steering wheel for deviation correction.









## 4. Operation of systems and equipment

No.	Icon	Designation	Color	Function
9		FCM indicator lamp *	Yellow	If the yellow indicator lamp comes on, it indicates that the FCM is faulty. In that case, please go to the GAC Motor authorized shop for inspection in time.
			Red	If the red indicator lamp flashes, it indicates that the FCM is being triggered and activated.
10		BSD system status indicator lamp *	Green	If the green indicator lamp comes on, it indicates that the BSD system is activated.
			Yellow	If the yellow indicator lamp comes on, it indicates that the BSD system is faulty.
11		Hands off warning lamp*	Green	If the green indicator lamp comes on, it indicates that hands on steering wheel is detected by ICA.
			Yellow	If the yellow indicator lamp comes on, it indicates that hands off steering wheel is detected by ICA.
12		LKA status indicator lamp*	White	If the white indicator lamp comes on, it indicates that ICA lateral control is in standby state.
			Green	If the green indicator lamp comes on, it indicates that ICA lateral control is activated.
			Yellow	If the yellow indicator lamp comes on, it indicates that ICA lateral control is faulty.
13		Cruise control indicator lamp*	White	If the white indicator lamp comes on, it indicates that the cruise control is in the ready state.
			Green	If the green indicator lamp comes on, it indicates that the cruise control is activated.
14		ACC indicator lamp (no vehicle ahead) *	White	If the white indicator lamp comes on, it indicates that the ACC is in the ready state, and there is no target vehicle ahead.
			Green	If the green indicator lamp comes on, it indicates that the ACC is working, and there is no target vehicle ahead.
15		ACC indicator lamp (a vehicle ahead) *	White	If the white indicator lamp comes on, it indicates that the ACC is in the ready state, and there is a target vehicle ahead.
			Green	If the green indicator lamp comes on, it indicates that the ACC system is working, and there is a target vehicle ahead.
16		ACC fault indicator lamp *	Yellow	If the yellow indicator lamp comes on, it indicates that the ACC system is faulty.
17		Right turn signal indicator lamp and hazard warning lamp	Green	If the right turn signal indicator lamp flashes alone, it indicates that the right turn signal lamp of the vehicle is on. When the hazard warning lamp switch is pressed, the left/right turn signal indicator lamps and all turn signal lamps will flash simultaneously.

## 4. Operation of systems and equipment

No.	Icon	Designation	Color	Function
18		Left turn signal indicator lamp and hazard warning lamp	Green	When the left turn signal indicator lamp flashes alone, it indicates that the left turn signal lamp of the vehicle is on. When the hazard warning lamp switch is pressed, the left/right turn signal indicator lamps and all turn signal lamps will flash simultaneously.
19		Electric park brake (EPB) status indicator lamp	Red	If the red indicator lamp comes on, it indicates that the EPB is applied.
			Green	If the green indicator lamp comes on, it indicates that the EPB is activated.
20		Electric park brake (EPB) fault indicator lamp	Yellow	If the yellow indicator lamp comes on, it indicates that the EPB is faulty.
				If the yellow indicator lamp flashes, it indicates that the EPB is in the service mode.
21		Parking brake and brake system indicator lamp	Red	If the red indicator lamp comes on, it indicates that the brake fluid level is too low or the electronic brake force distribution (EBD) system is faulty.
22		Electronic stability program (ESP) indicator lamp	Yellow	If the yellow indicator lamp comes on, it indicates that the ESP is faulty.
				If the yellow indicator lamp flashes, it indicates that the ESP is working.
23		ESP OFF Indicator lamp	Yellow	If the yellow indicator lamp comes on, it indicates that the ESP is off.
24		Anti-lock braking system (ABS) indicator lamp	Yellow	If the yellow indicator lamp comes on, it indicates that the ABS is faulty.
25		Transmission fault indicator lamp	Yellow	If the yellow indicator lamp comes on, it indicates that the transmission system is faulty.
				If the yellow indicator lamp flashes, it indicates that the transmission fluid temperature is high.
26		Tire pressure monitoring system (TPMS) indicator lamp	Yellow	If the yellow indicator lamp comes on, it indicates that the TPMS is faulty.
27		Electric power steering (EPS) indicator lamp	Red	If the red indicator lamp comes on, it indicates that the EPS system is faulty.
28		Front passenger's seat belt indicator lamp	Red	If the red indicator lamp comes on, it indicates that the front passenger's seat belt is not fastened or the system is faulty.
29		Driver's seat belt indicator lamp	Red	If the red indicator lamp comes on, it indicates that the driver's seat belt is not fastened or the seat belt system is faulty.

## 4. Operation of systems and equipment

No.	Icon	Designation	Color	Function
30		High beam indicator lamp	Blue	If the blue indicator lamp comes on, it indicates that the high beam is on.
31		Position lamp indicator lamp	Green	If the green indicator lamp comes on, it indicates that the position lamp, instrument panel lamp, license plate lamp, etc. are on.
32		Rear fog lamp indicator lamp	Yellow	If the yellow indicator lamp comes on, it indicates that the rear fog lamp is on.
33		Door ajar indicator lamp	Red	If the red indicator lamp comes on, it indicates that the engine hood, one of the doors or trunk lid is not closed.
34		Intelligent high beam indicator lamp*	White	If the white indicator lamp comes on, it indicates that the intelligent high beam is activated.
35		Rear seat belt indicator lamp*	White	If the white indicator lamp comes on, it indicates that the corresponding rear seat belt is fastened.
			Red	If the red indicator lamp comes on, it indicates that the rear seat belt is not fastened or the seat belt system is faulty.
36		ESP SPORT + indicator lamp	Yellow	If the yellow indicator lamp comes on, it indicates that the ESP is in SPORT + mode.
37		Virtual key connection indicator lamp*	Green	If the green indicator lamp comes on, it indicates that the Bluetooth key is connected.

Note: If any indicator or warning lamp on the instrument cluster comes on after the vehicle is started or during driving, it indicates that the related system or function is in a certain working state or faulty. Therefore, you should read carefully and understand the meaning of each indicator or warning lamp. In case of a fault, please go to or contact the GAC Motor authorized shop for inspection in time.



### 4.2 Vehicle locking and unlocking

#### 4.2.1 Remote control key

This vehicle is accompanied with two intelligent remote control keys (including emergency mechanical key) and the corresponding key barcodes. If the key needs to be re-customized, please inform the GAC Motor authorized shop of the key barcode. If the key barcode is missing, please inform the GAC Motor authorized shop of the VIN.

#### CAUTION

After the engine is started, do not place the remote control key on the instrument panel under the front windshield, otherwise the prompt "No key detected" may appear.

#### Poor signal strength of remote control key

The operation of the remote control key button may be interfered or unstable in the following cases:

- Nearby equipment is emitting strong radio waves.

- The remote control key is carried together with telecommunication equipment, laptop, mobile phone, access control card or wireless signal transmitter.
- The remote control key is put together with magnetic cards (such as bank card and bus card).
- Metal objects contact or cover the remote control key.

#### CAUTION

The remote control key contains an electronic circuit that can trigger the engine immobilizer system. If the circuit is damaged, the engine may not be started. Therefore,

- Avoid placing the remote control key in direct sunlight or in a high-temperature or humid place.
- Avoid dropping the remote control key from a high place or crushing it by heavy objects.
- Avoid exposing the remote control key to any liquid. If the key gets wet accidentally, dry it immediately.

#### NOTE

- The buttons of the remote control key cannot be operated when the vehicle power switch is set to the "ACC" or "ON" position.
- If the unlocking or locking function of the remote control key is deactivated, you can try to press the buttons on the remote control key 3 times continuously to activate the function.

## 4. Operation of systems and equipment

### Liftgate unlocking button



- ① : Locking button
- ② : Unlocking button
- ③ : Trunk lid unlocking button
- ④ : PEPS button

#### ① Button operation

- If this button is pressed once within the effective range of the remote control key, all doors will be locked; if this button is pressed and held for 2 s, the windows will be automatically closed; and if pressed and held for 3 s, the sunroof \* will be automatically closed; if the button is released when the windows or the sunroof \* is being closed automatically, the windows or the sunroof \* will stop moving.
- If this button is pressed twice consecutively within 0.5s, the vehicle locating function will be realized and the turn signal lamps will flash 3 times quickly.

#### CAUTION

Before closing the windows or sunroof \* by the remote control key, make sure that there are no body parts (such as head and hands) in the movement path of the windows or sunroof \* so as to prevent a risk of pinch injury.

#### NOTE

- If this button is pressed and held for 2 s, the four door windows will be automatically closed.
- When the doors are locked, the turn signal lamps will flash once and the horn will sound once. The horn prompt can be activated or deactivated via “System Settings → Sound Effect Settings → System Sound Effect → Unlocking/Locking Horn” in the AV system.

## 4. Operation of systems and equipment

### ② Button operation

- If this button is pressed once within the effective range of the remote control key, all doors will be unlocked; if this button is pressed and held for 2 s, the windows will be automatically opened, and if pressed and held for 3 s, the sunroof \* will be automatically tilted; if the button is released during the automatic opening or tilting of the windows or the sunroof \*, the windows or the sunroof \* will stop moving.

### CAUTION

After the button  is pressed to unlock the door, if the door is not opened within 30 s, the system will re-lock the door.



### NOTE

- When the doors are unlocked, the turn signal lamps will flash twice and the horn will sound twice. The horn prompt can be activated or deactivated via "System Settings → Sound Effect Settings → System Sound Effect → Unlocking/Locking Horn" in the AV system.
- The driver's door or all doors can be unlocked by pressing the button  after setting via "System Settings → Body Accessories → Locking/Unlocking → Remote Unlocking" in the AV system.

### ③ Button operation



- If this button is pressed twice within the effective range, the trunk lid will be unlocked.

### ④ Button operation

- Within the effective range, if the button  is pressed and then the button  is pressed and held within 5 s, the turn signal lamps will flash and the engine can be remotely started.
- Then if the button  is pressed and held for more than 3s, the engine can be remotely stopped.

## 4. Operation of systems and equipment

### **i** NOTE

- Before remotely stopping the engine, make sure that the vehicle is in the locked state, and if you are not sure about it, press the button  once, and then press and hold the button  to remotely stop the engine.
- To remotely stop the engine, keep the key within the effective range, otherwise the unlocking function may be triggered and then the engine cannot be started.
- The maximum default start hold duration is 5 min. If you need to change the duration, please go to GAC Motor authorized shop to change it.

### Battery replacement

Each time you press the buttons on the remote control key, the indicator lamp of the key will flash once. If the indicator lamp fails to flash, or you need to press the buttons several times to lock or un-lock the doors, the battery may be ex-hausted or about to run out. It is recommended to go to the GAC Motor authorized shop for the battery re-placement.

### CAUTION

- Be sure to replace the battery with a new one of the same model.
- An inappropriate battery may damage the remote control key.
- Always comply with relevant environmental regulations to dispose the exhausted battery.

### Battery replacement steps



- Press the locking button  and pull out the emergency mechanical key (arrow A).

## 4. Operation of systems and equipment

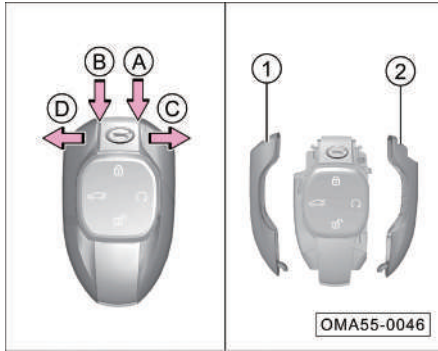

- Use a slotted screwdriver wrapped by cloth to pry open the chrome plated housing of the remote control key at positions (arrows A and B) in the direction of arrows C and D.
- Take off the chrome plated housings ① and ② of the remote control key.

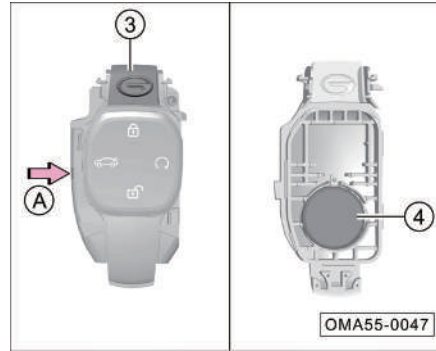

- Remove the transparent trim cover plate ③.
- Use a slotted screwdriver wrapped by cloth to pry open the housing of the remote control key at position (arrow A).
- Take out the remote control key battery ④.
- Assemble the remote control key in the reverse steps mentioned above.

### 4.2.2 Bluetooth key\*

#### 4.2.2.1 Download, installation and use instructions of Bluetooth key

The activation and authorization/vehicle control of the Bluetooth virtual key function depend on the GAC Motor APP. When the vehicle is equipped with the Bluetooth key function, you can download the GAC Motor APP through your mobile phone and follow the activation process to activate the Bluetooth key function.

If you want to use the Bluetooth key function, please ensure that your vehicle has the Bluetooth key permission, otherwise you will not be able to use the Bluetooth virtual key function. The mobile phone Bluetooth key needs to be connected to the smart Bluetooth parts in the vehicle (not AVNT Bluetooth).

If you want to use the Bluetooth key function, make sure that your phone meets the following basic requirements: The operating system of the mobile phone is Android 6.0 or above, or iOS 9.0 or above, and the Bluetooth of the mobile phone is BLE 4.2 or above.

## 4. Operation of systems and equipment

---

### Limitation of Rights

Limits on physical and virtual environments:

To use the smart Bluetooth key function, you need to ensure that the vehicle is parked in a safe area and that the mobile network in the environment is available. GAC will not assume responsibility for any system abnormality due to abnormal use of smart Bluetooth key and additional mobile phone fees for using the mobile network.

Make sure that your mobile phone is obtained through legal channels and is in a secure environment (that is, it is not root, hook, or debug). If your mobile phone cannot fully meet the above requirements, we will not assume any responsibility for any abnormal situation that may occur when using the Bluetooth key function.

### Limitation of use

To use the Bluetooth key, you need to open the GAC Motor APP on the mobile terminal of the Bluetooth key. If <GAC Motor> APP is shut down due to the automatic shutdown of the mobile phone system or your personal behavior, which may lead to the failure of the function of the Bluetooth key, we will not assume any responsibility.

The scope of bluetooth key services available to you depends on the model you purchased and the permissions of your account. Please understand that the smart Bluetooth key functions (such as the connecting speed between the Bluetooth and vehicle, the locating distance of Bluetooth) may be different or unstable due to different Bluetooth performance of different models of mobile phones.

We need to maintain Bluetooth key functions from time to time. If the service is interrupted within a reasonable period of time due to the above maintenance, we are not responsible for this, but we will make a notice in advance.

You can use the functions such as sharing and revoking the virtual Bluetooth key through the inquiry, change and deletion of personal information. However it should be noted that the text or pictures stored in the system will be deleted together with the information, which is at your own risk.

### 4.2.2.2 Precautions for Bluetooth key

For vehicles equipped with smart Bluetooth key, after binding with and activating the vehicle, you can use the function of smart Bluetooth key for vehicle control and ignition, and authorize other users to use your vehicle through the mobile phone APP.

For models equipped with smart Bluetooth key, after binding with and activating the vehicle, you can use the smart Bluetooth key to realize functions such as passive entry \*, vehicle control, and ignition, and authorize other users to use your vehicle through the mobile phone APP.

## 4. Operation of systems and equipment

### CAUTION

- The smart Bluetooth key is connected to the vehicle via mobile phone. The Bluetooth function on the mobile phone must be turned on and within the Bluetooth connection range of the vehicle. In an open area, the Bluetooth connection range may be more than 30 m. However, in certain situations, such as blockage by walls or other vehicle bodies, the connection range may be within 10 m only, which is normal.
- In order to ensure normal functioning of the smart Bluetooth key, please do not deactivate GAC Motor APP through background cleaning on the mobile phone.

### NOTE

- To ensure the operation safety, the system will automatically update the key after a period of activation, provided that the network of the mobile phone is activated. Please do not use the smart Bluetooth key with network deactivated for more than 3 months, in case the key expires and cannot operate the vehicle.
- The Bluetooth key function is based on the mobile phone APP. Please make sure your mobile phone is normally on when you use the smart Bluetooth key.
- The virtual Bluetooth key function is only used as a supplement to those for convenience for your travel. It is recommended to carry the spare physical key equipped to the vehicle for long-distance driving.
- Please observe domestic traffic and road laws and regulations during daily driving to ensure safe and legal driving. Otherwise, you shall bear the losses you may suffer.

### Control buttons

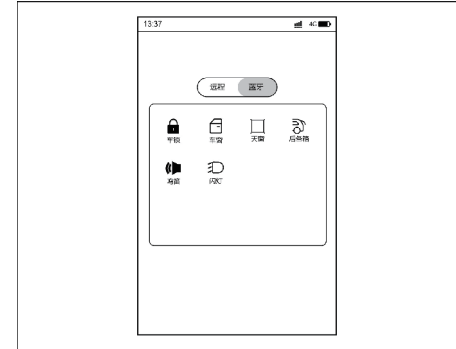

The Bluetooth key supports the controls of the following parts:

- Lock => See page 68.
- Window => See page 69.
- Sunroof\* => See page 69.
- Trunk => See page 70.
- Horn => See page 71.
- Lamp => See page 71.

## 4. Operation of systems and equipment

### 4.2.2.3 Basic operations of Bluetooth key

#### 1. Vehicle settings

##### ① Activation status-not activated

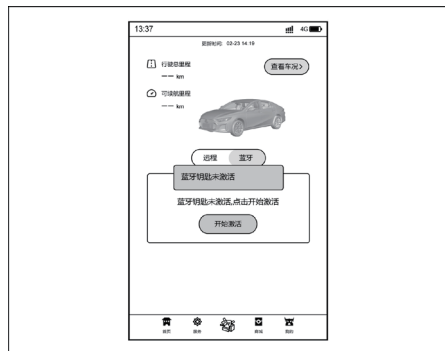

Enter the vehicle details page to obtain vehicle-related information, including bluetooth activation status:

- Activated: Display “Activated”.
- Not activated: Display “not activated” in red and “Activate” can be clicked.

Click the “not activated” column of bluetooth activation status to check whether the vehicle is currently connected:

- Yes, enter the Start Activation page.
- No, enter “Not currently connected Vehicle”.

#### 2. Bluetooth activation

##### Bluetooth connection pairing



- Register in CarPlay Assistant through your mobile phone, then activate the bluetooth key and pair the bluetooth on your phone with that of the vehicle. After a successful connection, you can use the bluetooth key function.



## 4. Operation of systems and equipment



After vehicle binding is completed, activation is required for the first use..

- Use your mobile phone to open the APP, and set the vehicle power switch to "ON" position. Click the "Start Activation" on the page of "Bluetooth Key Activation Guide" to start the Bluetooth activation program. After clicking, the button text changes to "Activating...".



- After successful activation, the screen of vehicle control via smart Bluetooth key will be entered.
- Otherwise, the user can choose to retry activation or return.

### 3. APP home page

Bluetooth key mode

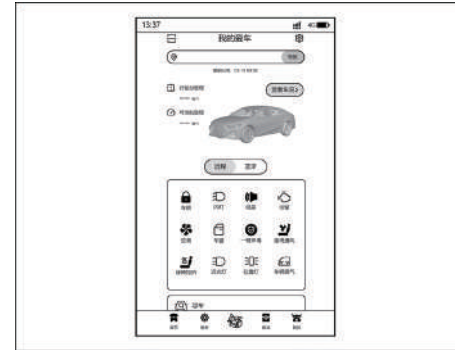

- After entering the APP for the first time, click "MyVehicle" to enter the vehicle settings, complete the vehicle binding, switch to the home page, and click "Connection Solutions" to switch the network connection to Bluetooth connection.
- The first use of the Bluetooth key requires "activation". After ignition with the original vehicle key, click "Activate" in the vehicle to activate the Bluetooth key.

## 4. Operation of systems and equipment

- For each reconnection after disconnection of mobile phone APP from Bluetooth module, the APP will perform a “safety initialization” to ensure the safety of your vehicle. If the security initialization is passed, the vehicle control command will appear. You can perform corresponding operations on your vehicle through the mobile phone APP, or you can start it with one click through mobile phone authentication without relying on the vehicle key. If the security initialization fails, the cause of the failure appears and the message of retry appears.

### i NOTE

Cause of failure: Initialization failed, activation check failed, and Bluetooth connection failed.

### 4. Bluetooth vehicle control

#### ① Lock



Click the lock button on the home page to enter the page and then perform the unlocking/locking operation..

- Click “lock”, the door will be locked, and the turn signal lamp will flash with a beep.
- Click “unlock”, the door will be unlocked, accompanied by two beeps and two flashes of turn signal lamp.

### i NOTE

If no operation is carried out within 2 minutes after unlocking, the vehicle will be automatically locked to ensure the vehicle safety.

## 4. Operation of systems and equipment

### ② Window



Click the window button on the home page to enter the page, and then operate the window.

- Click "Open Window" to lower the window.
- Click "Close window" and the window will rise.

### i NOTE

- After the click, the window starts to move. Please ensure that no people/object will be pinched or obstruct the window movement.
- During the window movement, if you click the reverse movement request, the window will perform the latest movement request. Do not operate the window too frequently, which may cause the window module to enter the thermal protection function and fail.

### ③ sunroof \*



Click the sunroof button on the home page to enter the page, and then operate the sunroof.

- Click "open sunroof" and the sunroof is opened.
- Click "close sunroof" and the sunroof is closed.

## 4. Operation of systems and equipment

### i NOTE

- After the click, the sunroof starts to move. Please ensure that no people/object will be pinched or obstruct the sunroof movement.
- During the sunroof movement, if you click the reverse movement request, the sunroof will perform the latest movement request. Do not operate the sunroof too frequently, which may cause the sunroof module to enter the thermal protection function and fail.

### ④ Trunk



Click the trunk button on the home page to enter the page, and then operate the trunk.

- Click "Open trunk", and the trunk is unlocked and opened.

### i NOTE

- For models without power liftgate, there is only one button "Open trunk" for the opening of trunk.
- When opening the trunk, please ensure that there is no people or obstacles around the trunk during opening.
- After the trunk is opened, make sure that the trunk is closed before moving the vehicle.

## 4. Operation of systems and equipment

### ⑤ Horn sounding



Click the horn button on the home page to enter the page, and then operate the horn.

- Click "Enable horn sounding" to start the sounding of horn.
- Click "Off" to stop the sounding of horn.

### i NOTE

- After clicking "Enable horn sounding", the horn of the vehicle starts to sound loud, which may cause nuisance, Use this function with caution.
- After the sounding of horn is enabled, it will be disabled automatically after 30s.

### ⑥ Lamp flashing



Click the lamp flashing button on the home page to enter the page, and then perform lamp flashing operation.

- Click "Enable lamp flashing" to start the lamp flashing.
- Click "Disable samp flashing" to stop lamp flashing.

### i NOTE

After the lamp flashing is enabled, it will be automatically disabled after 2 minutes.

## 4. Operation of systems and equipment

### 5. PEPS system



#### Function description

When the passive unlocking/locking function is activated, bring the smart Bluetooth key close to the vehicle within 2 m and touch the corresponding unlocking/locking position of the door handle to realize the passive unlocking function.

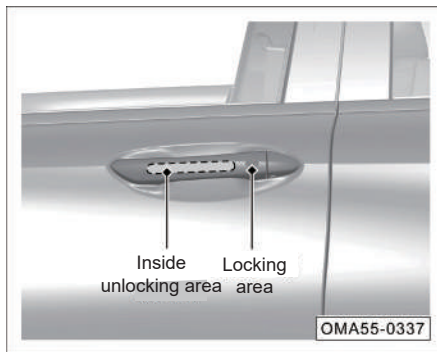

- When the vehicle power switch is set to "OFF" position, if you bring the smart Bluetooth key to approach the vehicle doors and put your hand into the unlocking area inside the front door handle, all the doors will be unlocked after effective induction.
- When the vehicle power switch is set to "OFF" position, if you take the smart Bluetooth key from the vehicle, close all the doors and touch the locking button, all the doors will be locked after effective induction.

#### CAUTION

- After using the PEPS function to lock the doors, please wait for 4 s before using it again to unlock the doors.
- If you touch the unlocking area and the locking button at the same time, priority will be given to the unlocking function. So please do not touch them at the same time.
- If there is snow or ice on the front door handle, the PEPS function will be affected, so please clear the snow or ice as soon as possible.
- If the front door handle gets wet and the smart Bluetooth key is within the effective range during heavy rain or vehicle washing, the doors may be unlocked.

### 6. ENGINE START/STOP button

#### Function description

Take the mobile phone with activated Bluetooth key and connect it with Bluetooth. Enter the vehicle and step on the brake pedal to ensure that P/N gear is displayed by the instrument. After the START/STOP button backlight color changes to green, press the START/STOP button to start the vehicle normally. The PEPS function of the smart Bluetooth key is the same as that of the intelligent remote control key.

Working conditions:

1. The mobile phone is equipped with GAC Motor APP and the Bluetooth key has been activated.
2. The Bluetooth of the mobile phone and the Bluetooth module of the vehicle are connected.
3. The phone is placed in the center console armrest area.
4. The gear is in P/N gear.
5. Apply the brake.

#### i NOTE

- During the startup process, please make sure that the mobile phone is placed near the center console armrest to ensure that the device in the vehicle can detect and locate the accurate position of the mobile phone. Other positions cannot guarantee that the mobile phone is detected to be in the vehicle.
- During startup, make sure that the GAC Motor APP is activated and connected and the Bluetooth is connected with the VIN number of same name.
- It is normal that the positioning of the mobile phone (sensed by the vehicle bluetooth) inside the vehicle is different from that outside the vehicle since different mobile phones have different Bluetooth.

### 7. Setting of Bluetooth key



Bluetooth key settings include three parts:

1. Bluetooth Calibration
2. Bluetooth Personalization
3. Bluetooth Fix

## 4. Operation of systems and equipment

### 8. Bluetooth Calibration

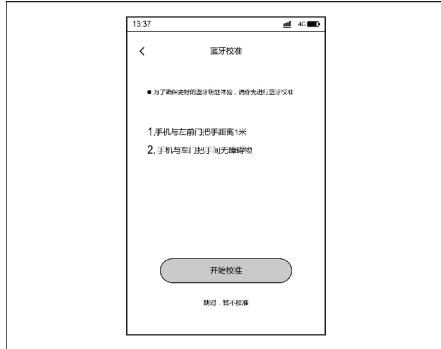

Click to enter the bluetooth calibration page to set up:

- Skip, do not calibrate for now: Click to skip this page and proceed to the next step.
- Start calibration: Click to enter the “Calibration countdown” page.

### Calibration countdown



Go to the Bluetooth calibration countdown page, click Start Calibration, start the 30s countdown, and start calibration at the same time.

- Calibration succeeded: The “Calibration Succeeded” box pops up.
- Calibration failed: If the calibration fails after 30 seconds, the calibration fails. Please try again.

### 9. Bluetooth Personalization



- Bluetooth personalization settings include: Passive unlocking and locking function settings\*, reminder of leaving setting.



## 4. Operation of systems and equipment

### Passive unlocking/locking function settings\*

- When this function is deactivated, touching the door handle unlocking/locking area with the Bluetooth key will not result in an unlocking/locking response.
- When this function is activated, touching the door handle unlocking/locking area with the Bluetooth key will result in an unlocking/locking response.

### Reminder of leaving settings

- After the function is disabled, the reminder of leaving is no longer performed.
- After this function is activated and the vehicle power switch is set to "OFF" position, if the state of the vehicle is abnormal when the bluetooth is disconnected, the reminder of leaving will be activated.

### 10. Bluetooth Fix



- When the user has saved the bluetooth connection information on the mobile phone and reinstalled the APP for use, the connection may fail depending on the mobile phone model. In this case, the user needs to follow the instructions on this page to clear the bluetooth pairing history in the mobile phone.

### 11. Reminder for leaving

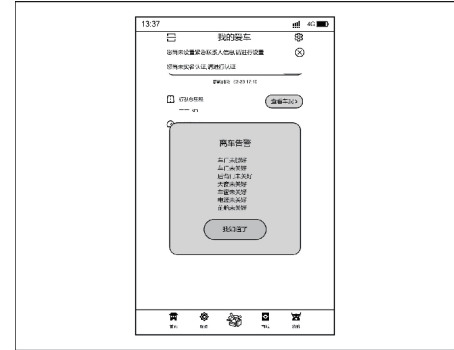

In order to ensure the vehicle safety when the user leaves the vehicle, the smart Bluetooth key allows for reminder for leaving.

- With the vehicle power switch set to "OFF" position, if the windows, sunroof, doors, engine hood and trunk lid are left open when the Bluetooth is disconnected, the APP will activate the function of reminder for leaving and notify the user through vibration, ring and pop-up box.

## 4. Operation of systems and equipment

### CAUTION

- The function of reminder for leaving is designed for giving reminder of vehicle state only, and will not close windows or lock doors automatically. After receiving the reminder, the user should return to the vehicle to eliminate the abnormality.
- If the user makes the mobile phone mute and deactivates the vibration function, the user may not be notified in time.

### 12. Bluetooth key expiration reminder



- After activation, the binding between the mobile phone and the vehicle will be updated automatically with the network connected in the background to ensure the safety of the vehicle.
- If the mobile phone is not connected to the network within a long time during operation of the APP, the Bluetooth update reminder will pop up when the Bluetooth key is about to expire. In that case, the user needs to run the APP for a period of time with the mobile phone connected to the network to ensure that the Bluetooth key update is completed in the background.

### CAUTION

- After receiving the "Bluetooth update reminder", the user should do the update in time to avoid the situation that the Bluetooth key is expired and cannot operate the vehicle normally.
- The update needs to be done with the mobile phone connected to the network for a short period of time. Please do it in good network environment.

### 4.2.3 Emergency mechanical key

#### Emergency mechanical key





- Press the locking button ① and pull out the emergency mechanical key (arrow A).
- The emergency mechanical key can be used to lock all doors or unlock the driver's door, but cannot be used to start the vehicle.

### 4.2.4 Door lock system

#### Central locking button



The central locking button ① can be used to lock and unlock the doors in the vehicle:

- Locking doors: Press the  end of the central locking button ① to lock all doors.
- Unlocking doors: Press the  end of the central locking button ① to unlock all doors.

#### Door inside handle



- If the vehicle is locked, pull any door handle once as arrowed to unlock that door only; pull the inside handle of that door again to open that door.
- If the vehicle is unlocked, pull any door handle once as arrowed to open the door directly.

## 4. Operation of systems and equipment

### **i** NOTE

When the child safety lock is activated (=> See page 79), even if the rear door latch is unlocked, the inside handle cannot open the rear door. In this case, the rear door shall be opened from outside. And do not pull the inside handle with force to avoid damages.

### **👁** CAUTION

- Before driving the vehicle, make sure that all doors are properly closed and locked.
- Do not pull the inside handle during driving to avoid accidents when opening the door.
- When opening or closing the door, check the surroundings of the vehicle, such as whether the vehicle is on a slope, whether there is enough space to open the door or whether there is strong wind. When opening or closing the door, please firmly hold the door handle to prepare for any unpredictable movement.

### Door lock hole

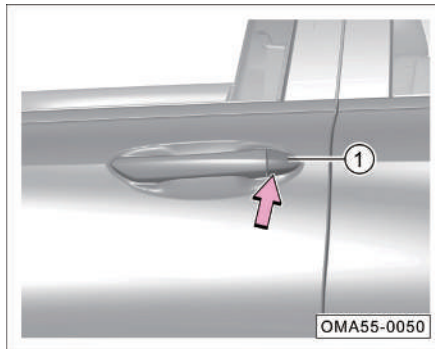

- Take out the emergency mechanical key.  
=> See page 77
- Insert the mechanical key into the notch on the trim cover of mechanical lock of left front door, gently pry the trim cover backward and outward as arrowed, pull up the door handle and remove the trim cover.

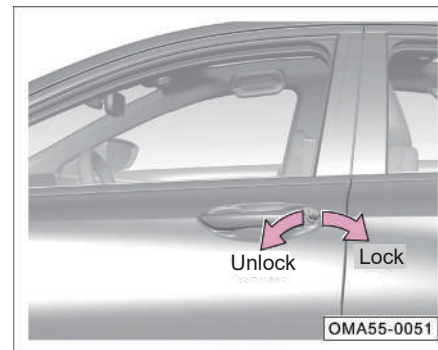

- Insert the emergency mechanical key into the driver's door lock hole.
- Turn the key clockwise to lock all the doors.
- Turn the key anticlockwise to unlock the driver's door only.

## 4. Operation of systems and equipment

### Child safety lock

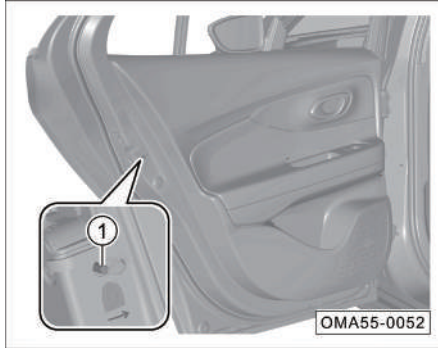

- Activation: Turn the child safety lock switch ① to the lock position as arrowed to activate the child safety lock.
- Deactivation: Turn the child safety lock switch ① to the unlocking position as arrowed to deactivate the child safety lock.

#### i NOTE

- The child safety lock can prevent children in the vehicle from unintentionally opening the rear door and thus reduce the risk of accidents.
- When the child safety lock is activated, the inside handle cannot open the rear door. In this case, the rear door shall be opened from outside. And do not pull the inside handle with force to avoid damages.

#### ⚠ WARNING

**Never leave children or handicapped persons in the vehicle alone. Once the doors are locked, it is difficult for children or handicapped persons to leave the vehicle in an emergency; the locked doors in an accident will make it more difficult to rescue persons inside the vehicle.**

### Automatic unlock function

If the vehicle stops with the doors locked and the vehicle power switch set to “OFF” position, the four doors will be automatically unlocked.

#### i NOTE

This function can be activated or deactivated by setting the “System Settings → Body Accessories → Lock/Unlock → Auto Unlock” of the AV system.

### Collision unlock function

With doors locked and the START/STOP button set to “ON” position, when the system detects that the vehicle has suffered a severe collision, all doors will be automatically unlocked. Depending on the impact force and impact range, the system may not work under extreme conditions.

## 4. Operation of systems and equipment

### Speed sensing door lock

If this function is activated with all doors closed, the vehicle will be automatically locked at certain vehicle speed.

With the vehicle power switch set to "ON" position, whether locked automatically or manually, all doors will be automatically unlocked if the system detects that the vehicle has suffered a severe collision. Depending on the impact force and impact range, the system may not work under extreme conditions.

#### **i** NOTE

- Please read the above related content before activating this function.
- This function of the delivered vehicle is deactivated by default, and can be deactivated/activated by setting the "System Settings → Body Accessories → Lock/Unlock → Speed Sensing Door Lock" of the AV system.

### Intelligent active unlock



- When the intelligent active unlock function is activated and the intelligent remote control key is within 1 meter from the vehicle, the vehicle will be automatically unlocked and the exterior rearview mirrors\* will be automatically unfolded.

#### **i** NOTE

- This function can be activated or deactivated by setting the "System Settings → Body Accessories → Lock/Unlock → Intelligent Active Unlock" of the AV system.
- If the intelligent active unlock is successful, the turn signal lamps will flash twice and the horn will sound twice.

### Intelligent active lock

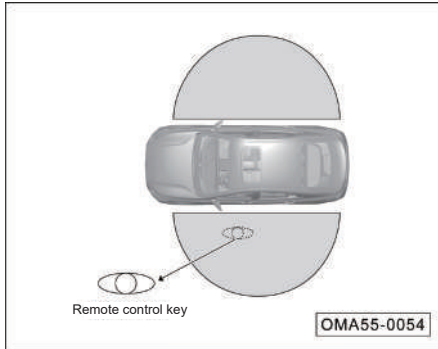

- When the intelligent active lock function is activated, the ENGINE START/STOP button is in the "OFF" position and all doors are closed, if the intelligent remote control key is taken away from the vehicle within 2 m for more than 2 minutes or more than 2 m, the vehicle will be automatically locked and the exterior rearview mirrors\* will be automatically folded.
- If the key is taken away from the car within 2 m for more than 2 minutes, the system will temporarily deactivate the intelligent active lock function for the purpose of power saving; the user needs to open and then close one of the doors to re-activate the intelligent active lock function.

- If the intelligent active lock function is activated and the key remains in an area within 2 m from the vehicle, the indicator lamp of the intelligent remote control key will flash continuously until the doors are locked.
- If one of the doors is ajar, there will be a corresponding indication on the instrument cluster.

### CAUTION

- With the intelligent active lock function activated, if the key is taken away from the vehicle to an area within 3 m from the vehicle for more than 2 min, the vehicle will confirm that the key is not within the vehicle and then be locked automatically; in case the time is longer than 4 min, the PEPS function will be deactivated.

### NOTE

- This function can be activated or deactivated by setting the "System Settings → Body Accessories → Lock/Unlock → Intelligent Active Lock" of the AV system.
- If the intelligent active lock is successful, the turn signal lamps will flash once and the horn will sound once.
- If one of the doors is ajar, there will be a corresponding indication on the instrument cluster.

## 4. Operation of systems and equipment

The intelligent active lock function will not be activated in case of the followings:

- The intelligent remote control key is in the vehicle.
- The vehicle power switch is set to "ACC" or "ON" position.
- No intelligent remote control key is detected within 2 m of the vehicle.
- The intelligent remote control key is thrown into the vehicle from the door window.
- The intelligent remote control key is too close to the vehicle.
- Any door (including the engine hood and the trunk lid) is ajar.
- The battery voltage is low.
- The PEPS antenna is faulty.

### CAUTION

- The intelligent active lock function cannot automatically close the door windows and sunroof \*, so before leaving the vehicle, make sure that all windows and sunroof \* are closed.
- Do not leave children or handicapped persons in the vehicle alone when using the intelligent active lock function.

### 4.2.5 Door

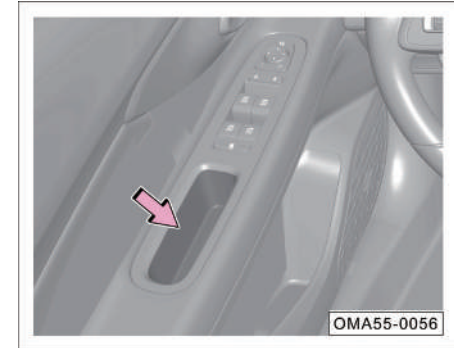

- To close the door in the vehicle, grab the door handle and pull it inward.
- To close the door outside, directly push the door toward the vehicle.

### CAUTION

- Before opening the door, always pay attention to other vehicles or pedestrians outside the vehicle to avoid accidents caused by collision.



### WARNING

- Make sure that all doors are closed before driving, otherwise accidents or injuries may occur.
- Open or close the doors only when the vehicle is stationary.
- Do not put your hands on the edge of the door when closing the door, otherwise there will be a risk of pinching.



### NOTE

- If the door is not closed properly, please re-open the door and close it again.
- If the door is ajar, there will be a corresponding indication on the instrument cluster; then when the vehicle speed exceeds 5 km/h, a buzzer will sound.

### 4.2.6 Trunk lid

#### Unlocking of trunk lid





1. Instrument panel button: If you press and hold the trunk lid unlocking button , the trunk lid will be unlocked.
2. Remote control key: When the vehicle power switch is set to "OFF" position, if you press the  button on the remote control key twice within the effective range, the trunk lid will be unlocked.

#### Easy Open function of trunk lid\*

When the vehicle power switch is in the "OFF" position and the four doors are closed, if the user carries the intelligent remote control key to enter the trunk Easy Open area, about 0.5 m away from the trunk, the horn will sound once (with the horn prompt function activated by setting the AV system), and the high-mounted stop lamp will flash at the same time. In this case, if the user stays or steps backward, the trunk lid will be unlocked. If the user leaves the trunk area while the high-mounted stop lamp is flashing, the trunk lid will not be unlocked.

## 4. Operation of systems and equipment

### **i** NOTE

- This function can be activated or deactivated by setting the AV system “System Settings → Body Accessories → Lock/Unlock → Trunk Easy Open”.
- If you carry the intelligent remote control key to approach the trunk within about 0.5 m, the high-mounted stop lamp will flash 4 times, and after 3.2 s, the trunk lid will be unlocked. If you don't want to open the trunk, just leave the trunk area within 3.2 s or press the  button on the intelligent remote control key to temporarily deactivate this function.
- If you want to re-activate the trunk Easy Open function after deactivating it by the  button on the intelligent remote control key, you need to open and then close one of the doors.

### Emergency unlocking of trunk lid

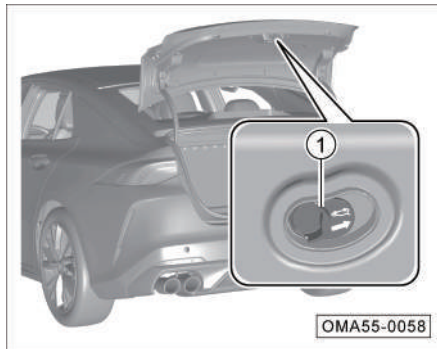

When the vehicle is out of power or the trunk lid fails to be opened normally, you can try the emergency interior opening of trunk lid:

- Push the emergency unlocking button ① to unlock the trunk lid.

### Locking of trunk lid

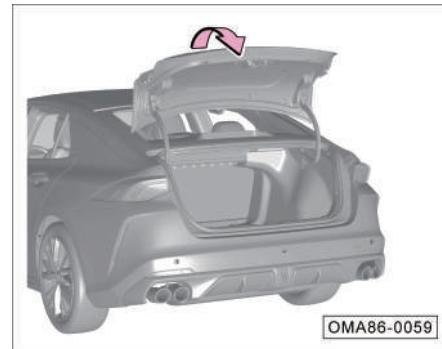

- Lower the trunk lid close to the rear bumper cover, and then press the trunk lid firmly to lock it.

### **i** NOTE

If the trunk lid is ajar, there will be a corresponding alarm indication on the instrument cluster; then when the vehicle speed exceeds 5 km/h, there will be a buzzer sound.

### **👁** CAUTION

- Be careful when closing the trunk lid to ensure that no person is within the movement range of the trunk lid.
- Always ensure that the closed trunk lid is locked to prevent suddenly opening during driving, which may cause an accident.
- Before closing the trunk lid, please check that the smart key is not left in it. To prevent the key from being accidentally locked in the trunk, the trunk lid will automatically pop open after closing if the key is left in the trunk.

### 4.2.7 Hood

#### Opening of engine hood

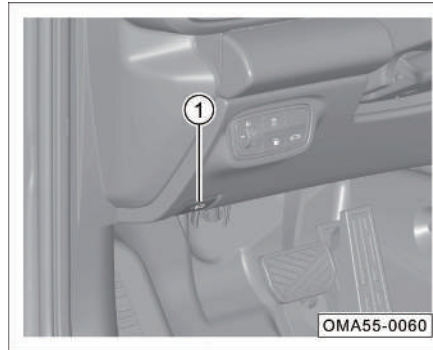

- When the engine hood release handle ① is pulled for the first time, the engine hood will be semi-unlocked and pop up slightly.
- When the engine hood release handle ① is pulled for the second time, the engine hood will further pop up slightly again and be fully unlocked. At this time, the engine hood can be opened outside the vehicle.

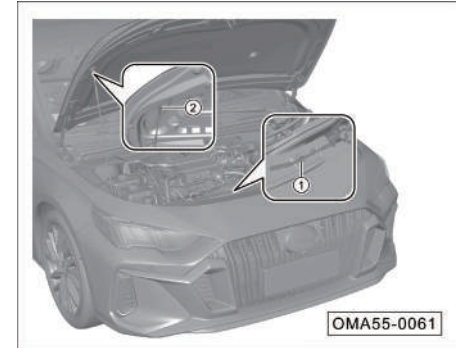

- Lift the hood up to the limit position, take out the stay bar from the stay bar bracket ①, and fix the stay bar in the fixing hole ② to support the hood at the limit position.

#### Closing of engine hood

- Take out the stay bar from the fixing hole ② and place it on the stay bar bracket ①; Lower the hood to a height of about 30 cm away from the lock body, and then let go to allow the hood to fall freely and then be locked.

## 4. Operation of systems and equipment

### WARNING

- Before driving, ensure that the engine hood is closed and locked, otherwise, it may suddenly open during driving, resulting in dangerous accidents.
- If the engine hood is ajar, there will be a corresponding alarm message on the instrument cluster display; When the vehicle speed exceeds 5 km/h, the buzzer will sound. In this case, please stop driving immediately and close and lock the engine hood correctly.

### CAUTION

- Please close all windows before leaving the vehicle.
- Do not put your hands on the edges of the windows when closing the windows, otherwise there will be a risk of pinching.

### 4.2.8 Power window

The power window can be operated when the ignition is in the “ON” position, and stays operable within 30 s after the ignition is switched from the “ON” position to the “ACC” or “OFF” position, but will become inoperable if any one of the doors is opened within this 30 s.

### Driver's power window control button

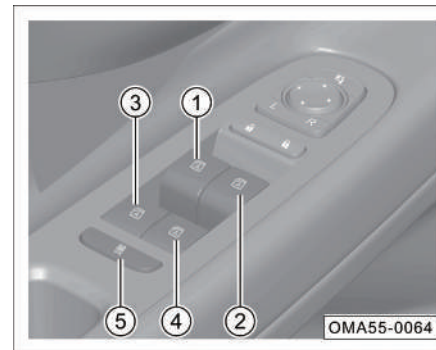

- ① Left front power window button
- ② Right front power window button
- ③ Left rear power window button
- ④ Right rear power window button
- ⑤ Passenger's window lock button

## 4. Operation of systems and equipment

- If the button ① is pulled up to the first stop position, the power window will be lifted for closing until the button is released or the window reaches the highest position.
- If the button ① is pulled up to the limit position, the power window will be lifted automatically for closing until the window reaches the highest position.
- If the button ① is pressed down to the first stop position, the power window will be lowered for opening until the button is released or the window reaches the lowest position.
- If the button ① is pressed down to the limit position, the power window will be lowered automatically for opening until the window reaches the lowest position.
- If you press the passenger's window lock button ⑤, the button indicator lamp will come on and the passenger's power windows cannot be operated anymore. If you press this button again, this function will be deactivated and the button indicator lamp will go out.

### **i** NOTE

If you want to stop the window during the automatic lifting or lowering, just press down/pull up the button ①.

- The operation methods of the buttons ②, ③ and ④ are the same as that of the button ①, only corresponding to the respective windows.

### Passenger's power window control button

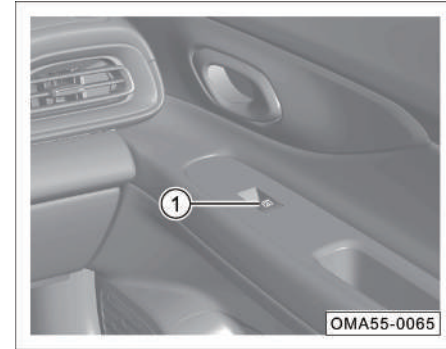

- For the operation methods of the passenger's power window control button ①, please refer to the driver's power window control button.

## 4. Operation of systems and equipment

### Initialization of anti-pinch function

If the express-up function is not available, or the anti-pinch function fails, or the initialization becomes invalid automatically because the anti-pinch function is triggered multiple times in a short period of time, the power window needs to be initialized again.

1. Pull up the power window control button, and then the window is lifted in steps until it is completely closed.
2. After the window is completely closed, continue to pull up the power window control button and hold it for 2~3 s to complete the initialization.



#### WARNING

- **The anti-pinch function of power window is disabled during initialization, and therefore, please do not use any part of your body or other objects to hinder the closing of the window, otherwise it will cause personal injury and affect the result of the initialization.**
- **If the power window system fails, please go to the GAC Motor authorized shop for inspection in time.**

### Locking-sensitive window closing function

If the vehicle is locked (by remote control, intelligent distance-sensitive locking and bluetooth locking) with any window opened, the system will automatically close all windows to prevent the vehicle from being damaged due to any opened window. This function can be activated or deactivated via “System Settings → Body Accessories → Other Accessories → Automatic Window Closing When Hirecar” in the AV system.

### Rain-sensitive window closing function \*

If you stop the engine, close the doors and leave the vehicle without closing any window, the system will detect the external environment of the vehicle in real time. When it rains, all windows will be closed automatically to prevent the vehicle from being damaged.

#### NOTE

This function is only configured on models equipped with automatic induction front wipers.

## 4. Operation of systems and equipment

### 4.2.9 Power sunroof \*

The power sunroof can be operated when the vehicle power switch is set to "ON" position; and stays operable within 30 s after the ignition is switched from the "ON" position to the "ACC" or "OFF" position, but will become inoperable if any one of the doors is opened within this 30 s.

#### **i** NOTE

When the ignition is in the "OFF" position with the power sunroof not closed and the driver's door opened, the instrument cluster will display the message "Sunroof Open" and send a buzzer sound; in this case, be sure to check whether the sunroof is closed.

#### **👁** CAUTION

Please close the sunroof, otherwise there will be a risk of water ingress on rainy days.

#### Sun visor \*



- Automatic opening of sun visor: The sun visor will be automatically opened as the sunroof is opened.
- Manual opening of sun visor: Push the sun visor backwards to open.
- Manual closing of sun visor: After closing the power sunroof, push the sun visor forward to close.

#### Opening or closing of sunroof

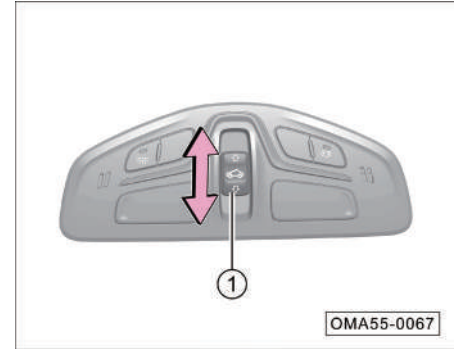

- To open the sunroof slightly, push the sunroof switch ① backward, and then the sunroof will move in the opening direction for a short distance and then stop.
- To close the sunroof slightly, push the sunroof switch ① forward, and then the sunroof will move in the closing direction for a short distance and then stop.
- To fully open the sunroof, push the sunroof switch ① backward and keep it for a certain period of time, the sunroof will automatically move to the fully open state (normal sunroof\*).

## 4. Operation of systems and equipment

- If you want to close the sunroof completely, push the sunroof switch ① forward and keep it for a certain period of time, the sunroof automatically moves to the fully closed state.

### **i** NOTE

- If the sunroof switch ① is pushed during the automatic opening or closing of the sunroof, the sunroof will stop at the current position.

### Tilting of sunroof

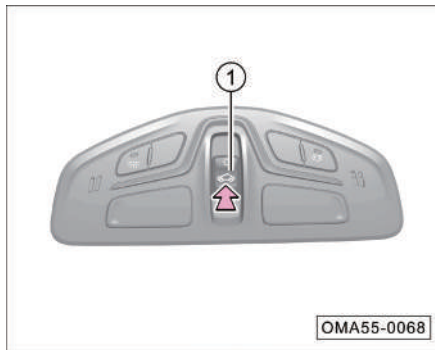

- When the sunroof is fully closed, if you manually open the sun visor and press the  button on the sunroof switch ①, the sunroof will be tilted outward. Just push the sunroof switch ① forward to deactivate the tilting function.

### Remote control

When you press and hold the button  on the remote control key with IGN OFF, the sunroof will be closed by remote control, and when you release the button, the sunroof will stop closing.

When you press and hold the button on the remote control key with the vehicle power switch in “OFF” position, the sunroof will be tilted. During the tilting process, the  button does not need to be hold, and the sunroof will stop after it is completely tilting.

### **i** NOTE

The remote control function can only realize remote tilting and closing. When the vehicle power switch is set to “OFF” position and the sunroof is opened, pressing and holding the button  of remote control key will not make the sunroof open.



## 4. Operation of systems and equipment

### Control of “soft switch” on center console display

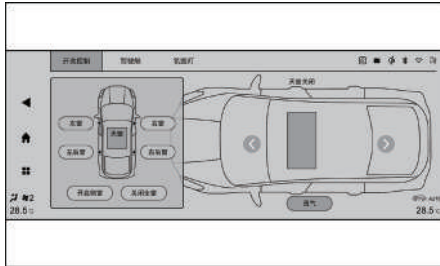

The opening or closing of the sunroof can be controlled by “soft switch” buttons such as “Ventilation” and “Slide” under “My Car” or in 3D vehicle model on the center console display.

### Speech operations

The speech operations can be used to open, close and tilt the sunroof:

- If you say “Open sunroof”, the sunroof will be fully opened automatically, during which the sun visor will be opened by the mechanical structure.
- If you say “Close sunroof”, the sunroof will be fully closed automatically. But the sun visor needs to be closed manually.
- If you say “I need some fresh air/Tilt sunroof”, the sunroof will be automatically opened first (so as to push open the sun visor), then closed and finally tilted.

### Anti-pinch function of sunroof \*

The anti-pinch function is available for the closing of the sunroof:

- When the sunroof is closed by sliding, if the anti-pinch function is activated, the sunroof will move in the opening direction for a certain distance and then stop.
- When the sunroof is closed by tilting, if the anti-pinch function is activated, the sunroof will move in the tilting direction until it reaches the maximum tilting position.

### CAUTION

Do not operate the sunroof when the ambient temperature is below  $-20^{\circ}\text{C}$ , at which the anti-pinch function of the sunroof may not be activated, resulting in accidents. In addition, the low temperature will also damage the motor to a certain extent.

## 4. Operation of systems and equipment

---



### WARNING

- **The anti-pinch function of the sunroof cannot prevent pinching of light or thin objects.**
- **When closing the sunroof, make sure that no one is within the movement range of the sunroof to avoid any pinching.**
- **The sunroof will stop detecting obstacles at a position where the sunroof is about to be closed fully, so the anti-pinch function will be deactivated at this time.**
- **Do not try to activate the anti-pinch function by your hand or any part of your body, otherwise there will be a risk of pinching.**

### Locking-sensitive sunroof closing function

If the vehicle is locked (by remote control, intelligent distance-sensitive locking and bluetooth locking) with sunroof opened, the system will automatically close the sunroof to prevent the vehicle from being damaged due to the opened sunroof. This function can be activated or deactivated via “System Settings → Body Accessories → Other Accessories → Automatic Window Closing When Hirecar” in the AV system.

### Rain-sensitive sunroof closing function \*

If you stop the engine, close the doors and leave the vehicle without closing the sunroof, the system will detect the external environment of the vehicle in real time. When it rains, the sunroof will be closed automatically to prevent the vehicle from being damaged.





### CAUTION

This function is only configured on models equipped with automatic induction front wipers.

### Manual initialization of sunroof



- Press the sunroof button ①  as arrowed to move the sunroof to the fully closed position.
- Continue to press and hold the sunroof button ①  as arrowed, the sunroof will execute “tilting → opening → closing”, and then release the sunroof button, by which the sunroof self-learning is completed.

#### CAUTION

If the power sunroof fails, please go to the GAC Motor authorized shop for inspection in time.

### 4.2.10 Basic operation of body anti-theft system

#### Body anti-theft function - unlock

When the ignition is in the “OFF” position and the vehicle is in the anti-theft state, if you bring the intelligent remote control key to approach the vehicle doors and press the UNLOCK button on the remote control key, all the doors will be unlocked to release the vehicle from the anti-theft state, and the turn signal lamps will flash twice.

#### Body anti-theft function - lock

When the vehicle power switch is in the “OFF” position and the four doors, engine hood and trunk lid are all closed, if you take the intelligent remote control key away from the vehicle and press the locking button on the remote control key, all the doors will be locked to enable the vehicle to enter the anti-theft state, and the turn signal lamps will flash once.

#### Activation of body anti-theft function

When the vehicle power switch is in “OFF” position and the vehicle is armed, if the door is unlocked by an illegal key or is forcibly unlocked, the anti-theft system will be activated, the anti-theft horn will sound and the turn signal lamps will flash.

When the vehicle is locked by remote control and enters the anti-theft state, if the driver’s door is unlocked with the emergency mechanical key, the anti-theft system will trigger the horn to sound and the turn signal lamps will flash.

#### NOTE

Before or during the anti-theft alarm is triggered, if you press the unlock button on the remote control key or set the vehicle power switch to the “ON” position, the anti-theft alarm will be disabled and the vehicle will be released from the anti-theft state; the alarm can be triggered up to 10 times in one cycle.

## 4. Operation of systems and equipment

### Engine immobilizer

When the vehicle power switch is set from the “OFF” position to the “ON” position with the body anti-theft state released and the legal key in the vehicle, if the engine immobilizer system passes the verification, it will be deactivated.

If the engine immobilizer system does not pass the verification, the engine cannot be started and an immobilizer alarm will be triggered.

### Body anti-theft maintenance instructions

No maintenance is required during normal use. If you have any doubt, please contact the GAC Motor authorized shop.

## 4.3 Lamps and vision

### 4.3.1 Exterior lamps

#### Lamp combination switch

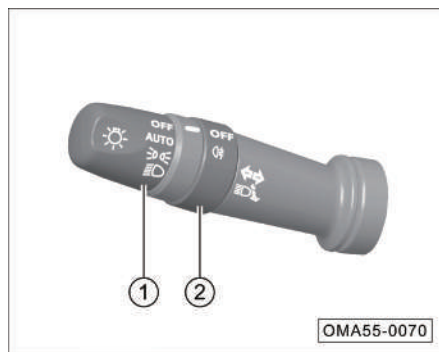

- ① Lamp switch
- ② Fog lamp switch

### i NOTE

- Water vapors or even water drops may appear on the inner surfaces of the lamps under certain conditions (such as high air humidity and vehicle washing conditions), similar to the fogging phenomenon on the windows when the vehicle is traveling in the rain, but this is not a malfunction.
- This fogging phenomenon can be eliminated by parking the vehicle in a dry environment, turning on the lamps or driving the vehicle, but may recur.
- If there are a lot of water drops or water ingress in the lamps, please contact the GAC Motor authorized shop for inspection.

## 4. Operation of systems and equipment

### Turn signal lamp

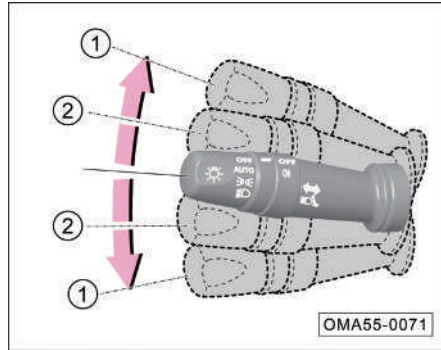

- When the vehicle power switch is in the "ON" position, if you turn the lamplight combination switch up or down to the limit position ①, the right or left turn signal lamp will go on, and the corresponding indicator lamp ➡ or ⬅ on the instrument cluster will flash.

### Turn signal lamp flashing for lane change

- In case of lane changing or overtaking, if you quickly turn the lamplight combination switch up or down to the position ② and then release it to the original position, the corresponding turn signal lamp and the indicator lamp ➡ or ⬅ on the instrument cluster will flash 3 times.

- If you turn the lamplight combination switch up or down and hold it at the position ②, the corresponding turn signal lamp and the indicator lamp ➡ or ⬅ on the instrument cluster will flash continuously. Releasing the switch to the original position can stop the flashing.

### CAUTION

If the corresponding indicator lamp ➡ or ⬅ on the instrument cluster flashes at the doubled frequency, one of the turn signal lamps may be faulty, and in this case, please go to the GAC Motor authorized shop for inspection in time.

### Lamp switch

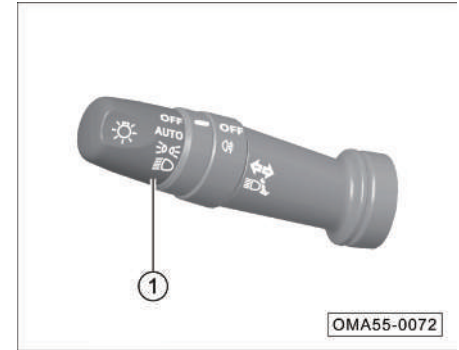

When the vehicle power switch is in the "ON" position, turn the lamplight control switch ① to turn on or off AUTO (automatic headlamp on/off function)\*, DRL (position lamp), and Ⓛ (low beam).

When the lamplight switch is turned to the "OFF" position, all lamps will go out.

## 4. Operation of systems and equipment

---

### AUTO (automatic headlamp on/off function)

\*

- Turn the lamplight switch to the AUTO position to activate the automatic headlamp on/off function.

#### **i** NOTE

- If the automatic headlamp on/off function is activated, the vehicle will automatically turn on or off the headlamp according to the ambient light. When the ambient light gradually becomes dark, the position lamps and the low beam will be turned on simultaneously; when the ambient light gradually becomes bright, the position lamps and the low beam will be turned off simultaneously.



#### CAUTION

- If the instrument cluster displays “Sensor Failure, Please Manually Control Light”, the system will keep the low beam on for the sake of safety. At this time, you should manually control the light and go to the GAC Motor authorized shop for inspection in time.
- The automatic headlamp on/off function may be affected in the haze environment, so please manually control the light in this case.

### Daytime running lamp\*

- When the engine is started and the position lamps are off, the daytime running lamps will be automatically turned on; when the low beam are turned on or the engine is shut down, the daytime running lamps will be automatically turned off.

### Position lamp

- If you turn the light switch to the position , the rear position lamps, instrument panel lamps, license plate lamps and other lamps will be turned on, and the corresponding indicator lamp  on the instrument cluster will come on.

### NOTE

If you forget to turn off the position lamps when the ignition is switched to the "OFF" position and the vehicle is not locked, the position lamps will stay on for 15 min and then go out automatically in order to save the battery power; when the ignition is switched to the "OFF" position and the vehicle is locked, the position lamps will go out immediately.

### WARNING

- **When driving the vehicle at night or on a road with poor visibility, please do not only turn on the position lamps. Otherwise, accidents may easily occur.**
- **When temporarily parking the vehicle at night or on a road with poor visibility with the need of indicating the position of the vehicle, do not use the position lamps as the parking lamps but be sure to turn on the hazard warning lamp due to the battery power saving function of the position lamps.**

### Low beam

- Turn the lamplight control switch to the  position to turn on the low beam.

### High beam

- After turning on the low beam, if you push the lamplight combination switch forward to the limit position, the high beam will be turned on and the corresponding indicator lamp  on the instrument cluster will come on.
- If you pull the lamplight combination switch backward to the original position, the high beam will be turned off.

### Headlamp flashing

- If you pull the lamplight combination switch backward to the limit position, the high beam will be turned on.
- If you release the switch, the lamplight combination switch will automatically return to its original position and the high beam will be turned off.

### NOTE

- The high beam may cause dazzling to drivers of oncoming vehicles at close range, which may easily cause accidents. Therefore, please use the high beam reasonably.
- When all the lamps are turned off, if you pull and hold the lamplight combination switch backward, the high beam will stay on, and the corresponding indicator lamp  on the instrument cluster will come on.

## 4. Operation of systems and equipment

### Manual headlamp leveling



Rotate the knob ① to manually level the headlamp (low beam) at 0, 1, 2 and 3 positions. The level of the headlamp will decrease as the adjustment value increases.

### Position lamp on warning

When the vehicle power switch is set to the "OFF" position with the position lamps on, if you open the driver's door, the system will send a buzzer sound and the instrument cluster display will display the message "Lamp On".

### Follow Me Home

Within 10 minutes after switching the ignition to the "OFF" position, if you turn the lamplight control switch from the "OFF" position to other positions and then back to the "OFF" position within 2 s, the headlamp delay off function will be activated. In this case, the low beam will stay on for 30s, within which if one of the doors (including four doors, hood and trunk lid) is opened, this function will be re-timed, and then the low beam will stay on for 80s, within which if all the doors are closed, this function will be re-timed again, and then the low beam will stay on for another 30s.

### Fog lamp switch



When the ignition is in the "ON" position with the position lamp or low beam turned on, turn the fog lamp switch ② to turn on or off the  (rear fog lamp).

- After the fog lamp switch ② is turned to the position  and then released to the position "OFF", the rear fog lamp will come on. Turn the fog lamp switch ② again to turn off the rear fog lamp.



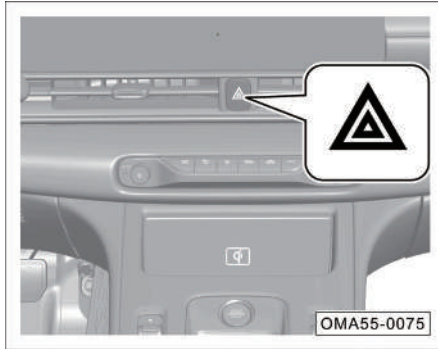

## 4. Operation of systems and equipment

### Hazard warning lamp



If you press the switch  with ignition in any position, the red indicator lamp on the switch will flash and the hazard warning lamp will be turned on. Press this switch again to turn off the hazard warning lamp.

If the hazard warning lamp is turned on, all turn signal lamps and the indicator lamps  and  on the instrument cluster will flash simultaneously.

The hazard warning lamp shall be turned on in the following cases so as to attract the attention of persons on the road and reduce the risk of traffic accidents:

- The vehicle is involved in any failure.
- The vehicle is at the tail end of a traffic jam.
- The vehicle tows another vehicle or is towed.
- The vehicle is temporarily parked due to poor visibility.



### NOTE

- The use of the hazard warning lamp will consume the battery power, so please turn it off when not in use.
- Be sure to strictly abide by the relevant regulations when using the hazard warning lamp.
- In the event of an emergency, if the hazard warning lamp is faulty, other methods that comply with the relevant traffic rules and regulations must be taken to attract the attention of persons on the road.

### Emergency braking warning lamp

- When the vehicle is traveling at a high speed and the emergency brake is applied, the brake lamps will come on and the turn signal lamps will flash.

### Vehicle assisted lighting

- If you press the unlocking button  on the remote control key within the effective range, the position lamps will stay on for 25 s for the purpose of helping you to approach your vehicle. If you press the unlocking button  on the remote control key again, the position lamps can stay on for another 25 s. When the vehicle power switch is set to the "ON" position, the position lamp will go out.

### Vehicle locating lighting

- If you press the locking button  on the remote control key twice within 0.5 s, the position lamps will stay on for 8 s and the turn signal lamps will flash 3 times for the purpose of helping you to locate your vehicle.

## 4. Operation of systems and equipment

### 4.3.2 Interior lamps

#### Automatic light-on function of dome lamps



- When the switch ① is pressed, the button indicator lamp will light up, and the automatic light-on function of the dome lamps will be activated; When the switch ① is pressed again, the button indicator lamp will go out, and the automatic light-on function of the dome lamps will be deactivated.

#### Delay off function of interior lamps

When the dome lamps are off and the automatic light-on function of dome lamps is activated:

- If the ignition is in the “OFF” position and one of the doors is opened, the dome lamps will come on automatically, and then go out about 30 s after the doors are closed.
- If the ignition is in the “OFF” position and the doors are unlocked by remote control, the dome lamps will come on automatically and then go out after about 30 s.
- If the vehicle power switch is set from the “ON” position to the “OFF” position, the dome lamps will come on automatically and then go out after about 30 s.

#### **i** NOTE

When all the doors are closed and the dome lamps are on as mentioned above, if the vehicle is locked by remote control or the vehicle power switch is set to the “ON” position, the dome lamps will go out automatically.

#### Dome lamp



- When the dome lamps are off and the switch ② is pressed, the button indicator lamp will come on and all the dome lamps will come on. when the switch ② is pressed again, the dome lamps will go out.

#### **i** NOTE

The switch ② will be invalid if it is not used to turn on the front dome lamps.

## 4. Operation of systems and equipment

### Front dome lamp





- When the front dome lamps are off, if one of the front dome lamp buttons ③ is depressed, the front dome lamp on the corresponding side will be turned on; When the front dome lamp button ③ is pressed again, the front dome lamp on the corresponding side will be turned off.

### **i** NOTE

The front dome lamp button ③ will be invalid if it is not used to turn on the front dome lamps.

### Rear dome lamp\*



- When the rear dome lamp is off, press  to turn on the rear dome lamp, and press  to turn off the rear dome lamp.
- When the rear dome lamp button is in a level state, i.e. position , it can be turned on by opening the door or pressing the front dome lamp button.

### Trunk lamp

- If the trunk lid is opened, the trunk lamp will come on automatically.
- If the trunk lid is closed, the trunk lamp will go out automatically.

### Vanity mirror lamp\*

- If the vanity mirror cover is opened, the vanity mirror lamp will come on automatically.
- If the vanity mirror cover is closed, the vanity mirror lamp will go out automatically.

## 4. Operation of systems and equipment

### Smart ambient light\*

Operation interface description:

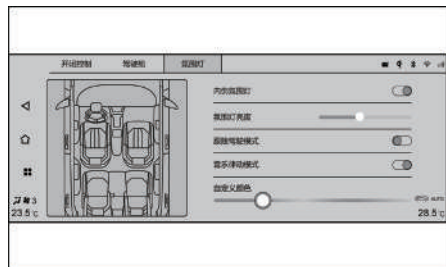

#### Ambient light switch

- Click the interior ambient light soft key to activate/deactivate the ambient light function.
- When the ambient light function is deactivated, other parameters cannot be adjusted

#### Ambient light brightness adjustment

- Users can adjust the brightness of ambient light by clicking or sliding the ambient light brightness progress bar.

#### Drive mode following

- When the drive mode following function is activated, the color of the ambient light and the music rhythm will change along with the drive mode. Users can set the ambient light color and the music rhythm for each driving mode on the 4 + X interface.

#### Music rhythm mode

- If the music rhythm mode is activated, the ambient light will change along with the music rhythm when the music is played.

#### Ambient light color

- Users can select the ambient light color by dragging or clicking on the color bar.

#### Ambient light settings

Enter the AVNT interface "My Car → ambient light → drive mode following" and click  soft button to activate/deactivate.

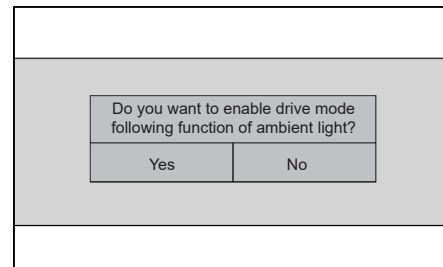

- After the drive mode following function is deactivated, if users adjust the music rhythm mode or ambient light color on the 4 + X interface, a pop-up box will remind the user "whether to activate the drive mode following function of ambient light".
- After the drive mode following function is activated, the user can customize the ambient light color and music rhythm switch in the current driving mode.
- When the user increase the temperature of the air conditioner, the ambient light on instrument panel will be highlighted with red for 2s and then return to the original state; When the user decrease the temperature of the air conditioner, the ambient light on instrument panel is highlighted with blue for 2s and then return to the original state.

## 4. Operation of systems and equipment

### 4.3.3 Wiper combination switch

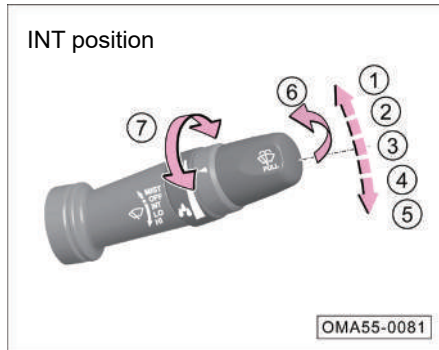
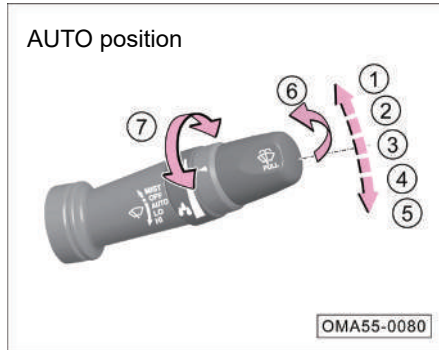

When the vehicle power switch is in the “ON” position, the wiper combination switch can be operated as follows:

① MIST: Continuous wiping

② OFF: Front windshield wiper off

③ AUTO: Automatic wiping \*

- INT: Intermittent wiping operation \*

④ LO: Low-speed wiping

⑤ HI: High-speed wiping

⑥ : front windshield washer system on

⑦ Adjusting knob:

- Adjust the sensitivity of automatic wiping (AUTO)\*

- Adjust the intermittent wiping (INT)\*

#### MIST: Continuous wiping

- If the wiper combination switch is turned to the ① MIST position, the front wiper will start wiping continuously.
- If the wiper combination switch is released to automatically return to the ② OFF position, the front wiper will stop wiping.

#### OFF: Wiper off

- If the wiper combination switch is turned to the ② OFF position, the front wiper will stop wiping.

#### AUTO: Automatic wiping \*

- If the wiper combination switch is turned to the ③ AUTO position, the automatic wiping function will be activated, and the wiper system will adjust the wiper speed according to the current rainfall and the real-time vehicle speed.
- This function can be activated or deactivated by setting the AV system “System Settings → Body Accessories → Other Accessories → Auto Wiping”. When this function is deactivated, the function of the wiper in the AUTO position is equivalent to that in the INT position.

## 4. Operation of systems and equipment

- Adjust the wiping sensitivity by turning the knob / ⑦ up/down.

### CAUTION

- If the instrument cluster displays “Sensor Failure, Please Manually Control Wiper”, for the sake of safety, you should manually control the wiper and go to the GAC Motor authorized shop for inspection in time.
- Before activating the automatic wiping function in winter, please check whether the wiper blade is frozen.
- It is recommended to deactivate the automatic wiping function when washing the vehicle, in dusty weather and in rainless weather to avoid unintentional action of the wipers which may cause damage or personal injury.
- The automatic wiping function is an assist, so the driver should manually operate the wipers when necessary according to the driving situation to ensure driving safety.

### **INT: Intermittent wiping operation \***

- If the wiper combination switch is turned to the ③ INT position, the front wiper will start wiping intermittently.
- For the models equipped with the automatic wiping function, this function can be activated by setting the AV system “System Settings → Body Accessories → Other Accessories → Auto Wiping”.
- Adjust the intermittent wiping speed by turning the knob ⑦ up/down.

### **LO: Low-speed wiping**

- If the wiper combination switch is turned to the ④ LO position, the front wiper will wipe at a slow speed.

### **HI: High-speed wiping**

- If the wiper combination switch is turned to the ⑤ HI position, the front wiper will wipe at a high speed.

### **Front windshield washer system on**

- If the wiper combination switch is turned toward the rear of the vehicle to the ⑥ position, the front washer will start spraying water and then the front wiper will start wiping.
- If the wiper combination switch is released to return to its original position, the front windshield washer system will be stopped and the front wiper will wipe once after 6s.
- After the front wiper stops wiping for 6 s, it will wipe once again so as to clear the residual water stains from the glass.

### **Front wiper maintenance**

- Within 10 s after turning the vehicle power switch to the “OFF” position, if you turn the control lever of the wiper combination switch to the MIST position and then quickly release it to return it to the original position, the front wiper will move to the highest position and then stop.

### 4.3.4 Windshield



#### Windshield glass

The green sound-insulation and laminated anti-scattering glass is used for the front windshield, which can effectively reduce the personal injury in an accident.

#### WARNING

- Always keep the glass surface clean.
- Please affix the necessary identifications according to local traffic laws, rules and regulations. Do not stick paper or hang objects on the surface of the front windshield glass, otherwise the front view will be obstructed, which may easily cause traffic accidents.

## 4. Operation of systems and equipment

### 4.3.5 Exterior rearview mirror

#### Interior rearview mirror

##### Auto dimming interior rearview mirror \*

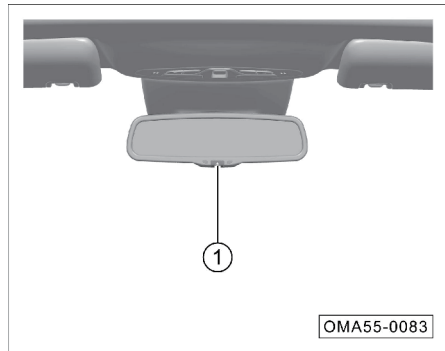

The auto dimming interior rearview mirror monitors the light in front and rear of the vehicle according to the light sensor, and reduces the glare reflected off the rear to the mirror surface, thus realizing the optimal rear view.

- When the vehicle power switch is in the “ON” position, the auto dimming function will be automatically activated and the switch indicator lamp will come on. Press the switch ① to manually activate or deactivate this function. When this function is deactivated, the switch indicator lamp will go out.

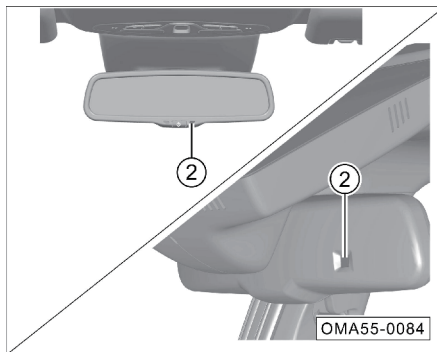

#### CAUTION

Do not cover the light sensor ② in order to ensure its normal function.

#### NOTE

If the inside temperature is low, the anti-glare rearview mirror may take a longer time to reduce the glare.

##### Manual anti-glare interior rearview mirror\*



Manually adjusting the manual anti-glare interior rearview mirror can reduce the light reflected off the mirror surface, thus realizing the optimal rear view.

- As shown in the figure, the tab is at a rearview normal position, which can be pulled forward to offset the light reflected off the mirror surface to achieve the anti-glare function.
- Push the tab backward to return to the normal rearview angle.



## 4. Operation of systems and equipment

### Exterior rearview mirror

#### WARNING

Although the curved (convex and spherical) rearview mirror can expand the field of view, the reflected object image is smaller and farther than the real object. Therefore, when changing the lanes, do not judge the distance between your vehicle and the following vehicle by the reflected image, otherwise accidents may occur due to wrong judgment.

#### NOTE

If the function of the exterior rearview mirror fails, please go to the GAC Motor authorized shop for inspection in time.

### Electric adjustment



- Press “L” or “R” end on the selection button ① to select the left or right exterior rearview mirror.
- Press the adjusting button ② to adjust the selected exterior rearview mirror to the appropriate rearview angle.
- After adjusting the exterior rearview mirror, restore the selection button ① to its original state.

### Electric folding \*



- Press the folding button ③ to fold the exterior rearview mirror electrically.
- Press the folding button ③ again to unfold the exterior rearview mirror electrically.

#### Automatic folding \*

- If the vehicle is locked from outside, the exterior rearview mirror will be folded automatically.
- If the vehicle is unlocked from outside, the exterior rearview mirror will be unfolded automatically.

## 4. Operation of systems and equipment

### NOTE

This function can be activated or deactivated by setting the “System Settings → Body Accessories → Other Accessories → Auto Folding of Exterior rearview Mirror” of the AV system.

### CAUTION

- If the exterior rearview mirror does not feature the electric folding function or the electric folding function fails, the mirror can be manually folded and then manually unfolded. A click sound can be heard when the mirror is manually unfolded.
- Be careful when operating the electric folding function of the exterior rearview mirror to prevent your fingers from being pinched by the rearview mirror and its base.

### Turning down of exterior rearview mirror when reversing\*

This function is to automatically turn down the exterior rearview mirror at a certain angle when reversing, so that the driver can observe the rear situation.

Memory of turning down position of exterior rearview mirror when reversing:

- Set the vehicle power switch to the “ON” position, enter the AV system “System Settings → Body Accessories → Other Accessories”, and click the “Settings” soft button of the reverse tilt-down function.
- Adjust the exterior rearview mirror on both sides to a suitable reversing position. After the adjustment, click “OK”, and this position is stored as the reverse tilt-down position.

Activation of “Reverse Tilt-down” function

- Set the vehicle power switch to the “ON” position, enter the AV system “System Settings → Body Accessories → Other Accessories” and activate the “Reverse Tilt-down” function.
- Depress the brake pedal and shift the gear to “R” position.
- The exterior rearview mirrors on both sides are automatically turned down to the memory positions.

### NOTE

If the gear is switched out of the “R” position, or the vehicle speed exceeds 5 km/h, or the vehicle power switch is set to OFF/ACC position, or the Reverse Tilt-down function is configured to be turned off, the mirror will automatically return to the position before the tilt-down.

## 4. Operation of systems and equipment

### Defrosting and defogging function \*

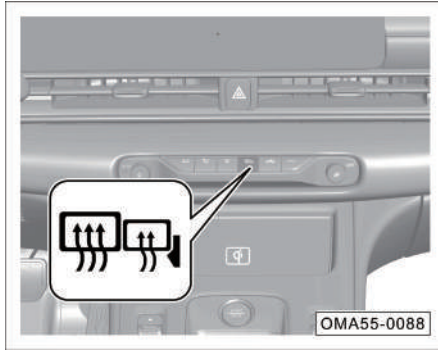

- If the button  is pressed, the button indicator lamp will come on, and the defrosting and defogging function will be activated to clear the fog or frost on the exterior rearview mirrors and the rear windshield.
- This function will be deactivated automatically after about 15 min or pressing down the button again can manually deactivate this function; when the heating function is deactivated, the button indicator lamp will go out.

### CAUTION

- If there is residual fog or frost after the defrosting and defogging function is deactivated automatically, just press the button  again.
- Do not keep the defrosting and defogging function on for a long time, otherwise the heater may be damaged due to overheating.
- If the defrosting and defogging function is out of use, please deactivate it to avoid wasting battery power.

### 4.3.6 Sun visor

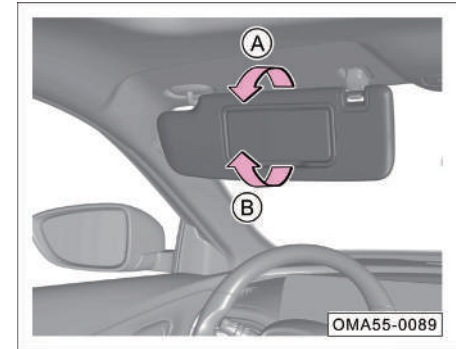

- Turn down the sun visor on the driver's side or front passenger's side in the direction of arrow A to shelter from the incoming sunlight from the front windshield.
- To use the vanity mirror, flip down the sun visor and pull open the vanity mirror cover in the direction of arrow B, and then the vanity mirror lamp \* comes on automatically.

## 4. Operation of systems and equipment

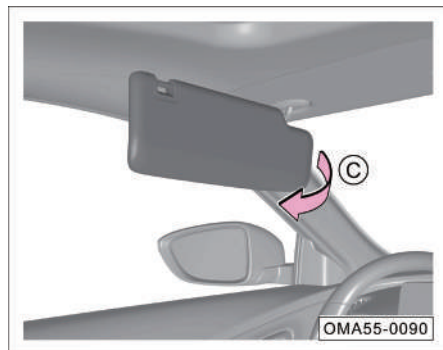

- After turning down the sun visor on the driver's side or front passenger's side, pull it out from the movable bracket in the direction of arrow C to shelter from the incoming sunlight from the side window.

### **i** NOTE

When the vehicle power switch is in the "OFF" position or the vehicle is locked for a few minutes, the vanity mirror lamp will go out automatically.

## 4.4 Seats and storage facilities

### 4.4.1 Headrest

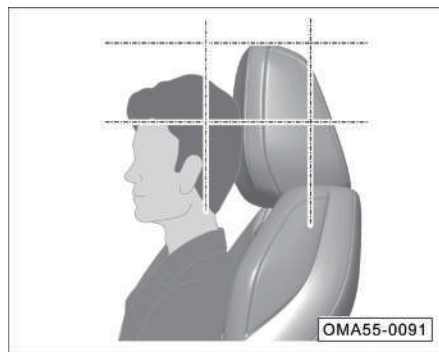

Correct adjustment of the headrests is essential to protect the occupants and reduce the personal injuries in accidents.

All occupants must adjust the headrests to the correct position (as shown in the figure) according to their body shape.

### **⚠** WARNING

In order to reduce the risk of accidental casualties, please strictly observe the followings:

- Do not adjust the headrest while driving.
- Always keep the head restraint in its installation position. If the headrest is removed or installed improperly, the driver may be seriously injured in an accident.

### Height adjustment of front seat headrests



- Down: Press and hold the lock button ①, and press down the headrest to the desired position.
- Up: Lift up the headrest directly to the desired position.

#### i NOTE

The adjustment method of other seat headrests is the same.

### 4.4.2 Front seat

#### i NOTE

When measuring the depth of the seat cushion, be sure to adjust the front and rear positions of the seat to the middle of the slide rail and the seat back to the normal operating state (25°).

#### ⚠ WARNING

- **Do not place objects under the front seats, for these objects may be caught between the seat and the slider rail, hindering the seat from being locked.**
- **Do not adjust the seats when the vehicle is traveling as this is likely to cause casualties. Therefore, please adjust the front seat only when the vehicle is in a stationary state.**
- **Never leave children alone in the vehicle, because the power seat\* adjustment mechanism still works after the vehicle power switch is set to the "OFF" position, and if the children accidentally operate the power seat, it may cause an accident.**

### Power seat \*

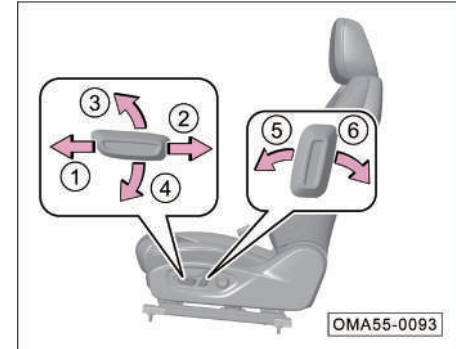

Forward and backward adjustment of seat:

- Push the switch in the direction of arrow ① or ② to adjust the seat to slide forward or backward.

Upward and downward adjustment of seat:

- Pull the switch in the direction of arrow ③ or ④ to adjust the seat upward or downward.

Forward and backward adjustment of seat back:

- Pull the switch in the direction of arrow ⑤ or ⑥ to adjust the seat back to slide forward or backward.

## 4. Operation of systems and equipment

### Manual seat\*

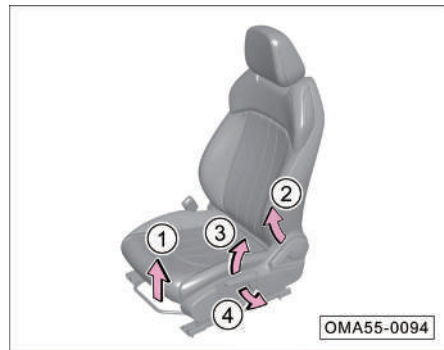

Forward and backward adjustment of seat:

- Pull the adjusting handle in the direction of arrow ① to adjust the seat to slide forward or backward. Then release the adjusting handle, and slide the seat forward or backward slightly until the seat is firmly locked.

Forward and backward adjustment of seat back:

- Pull up the adjusting handle in the direction of arrow ② to adjust the seat back to a desired position, and then release the handle.

Upward and downward adjustment of seat (only for driver's seat) \*:

- Pull the switch in the direction of arrow ③ or ④ to adjust the seat upward or downward.

### Adjustment of driver's seat lumbar support\*

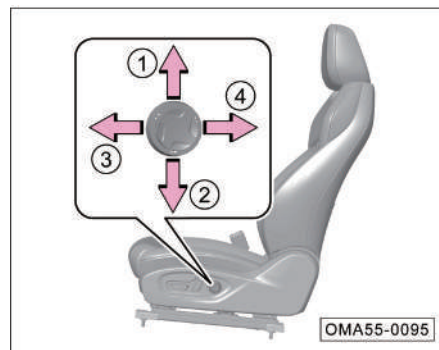

- Press the switch in the direction of arrow ①, ②, ③ or ④ for upward and forward support, and downward and backward contraction respectively.

### Seat heater\*

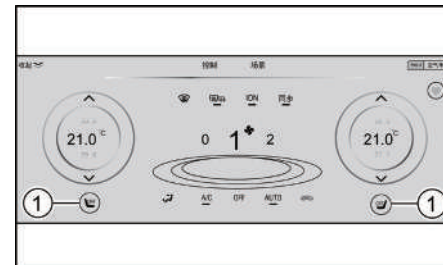

- Switch the vehicle power switch to the "ON" position.
- Switch the AV system to the air conditioning control interface, click the OFF or OFF soft button ① to enter the page of next level and select the seat heating mode or turn off the seat heating function.

## 4. Operation of systems and equipment

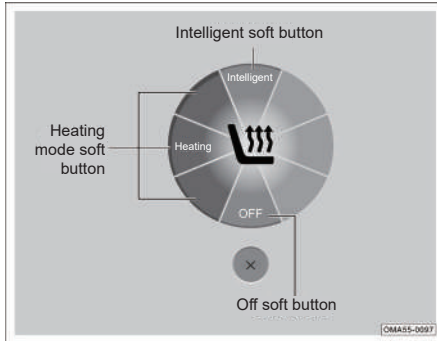

- Click the mode soft button in the seat heating area to turn on the seat heating function.
- Click the "Intelligent" soft button to turn on the seat intelligent heating function which will set the heating mode for you based on the current temperature.
- Click the "Off" soft button to turn off the seat heating function.

The seat heater has three heating positions, that is, , and , corresponding to three different seat surface temperatures, among which the 3rd position has the highest temperature followed by the 2nd position, and the 1st position has the lowest temperature.

If you click any soft button during the intelligent heating process, the intelligent heating mode will exit.

### i NOTE

- The seat heater switch has no physical button and also no display on the main interface of the AV system. You need to click on the A/C status display area in the lower left/right corner of the AV system interface to enter the A/C control interface for adjustment.
- The seat heating function can also be controlled and operated by voice or GAC Motor APP.

### ⚠ WARNING

**If you are sensitive to the temperature change of the seat heater function, please do not use this function to avoid burns by the heater.**

## 4. Operation of systems and equipment

### CAUTION

- Do not kneel on the seat or apply pressure to a point on the seat cushion or seat back, in order to avoid damaging the electrical components in the seat.
- If you feel no temperature change of the seat for a long time or feel hot after turning on the heater, please immediately turn off the seat heater and go to the GAC Motor authorized shop for inspection in time.

### Convenient for driver to enter and exit\*

This function can be activated or deactivated by setting the A/V system “System Settings → A/C & Seat → Seat → Convenient for driver to enter and exit”, and when this function is activated:

- When the vehicle power switch is set to the “OFF” position and the driver’s door is opened, the seat is automatically retracted to the position convenient for driver to enter and exit.
- When the vehicle power switch is set to the “ON” position, the seat will automatically return to its original position.

### CAUTION

If the position of the seat is manually changed after the seat has been retracted to the position convenient for driver to enter and exit, the seat will not move the next time you get in the vehicle and set the vehicle power switch to the “ON” position.

### Associated memory/retrieval function of GAC application account

Different drivers can automatically obtain the positions of the associated seat and exterior rearview mirror by logging in to GAC motor account, so as to realize the intelligent user experience of adaptive driver habits.

1. Account associated memory
  - After logging in to the account, the user can manually adjust the seat/exterior rearview mirror, the AV main unit interface will pop up a box to prompt the user whether to save the current driver position, and the user can click Save to memorize the current position in the corresponding account.
2. Account associated retrieval
  - When the user logs in to the account, the seat/exterior rearview mirror automatically adjusts to the memory position corresponding to the login account.
  - When the user clicks the retrieval button in the pop-up box, the seat/exterior rearview mirror will be automatically adjusted to the position memorized in this account.



## 4. Operation of systems and equipment

### Nap mode\*

When the vehicle power switch is set to the ON position and the transmission is in P gear, the driver can set and save the nap mode position through “Drop-down menu → Nap mode”, and then have a rest and relax.

- When entering the nap mode for the first time, it is necessary to set and save the nap mode position. After adjusting the seat position, click “Save Position and Enable” to keep the nap mode at the current position.
- When the nap mode has a memorized position and you enter the nap mode again, you can click “Enable” to enter the nap mode, and click “Cancel” to exit the nap mode and return to the previous position.
- After entering the nap mode, if the seat position is adjusted, the box will be popped up to prompt “save” the new position or “off mode”.
- When the nap mode has a memory position, if the user switches out of P gear, the nap mode will be exited and the seat will not move; When the vehicle power switch exits the ACC/OFF position, the user can exit the nap mode by vice, or click the “Exit” through the central controller to exit nap mode. After the system exits the nap mode, the seat returns to the previous position.

### CAUTION

- When the system is in the nap mode setting state: If any seat motor is not in a static state when you click “Save position and enable”, the system will ignore this memory request signal, exit the setting state of nap mode, and perform the recovery action of nap mode.
- When the system is in the nap mode: If any seat motor is not in a static state when your click “Save”, the system will ignore this memory request signal and maintain the nap mode.

### 4.4.3 Rear seat

#### Folding down of rear seat backs

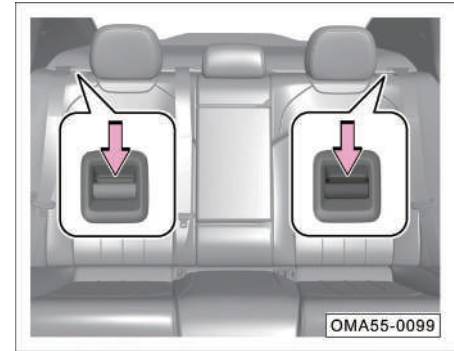

- Folding down: Press the rear seat back switch as arrowed to fold down the rear seat back.
- Restore: Push the rear seat back directly backward until the seat back is locked.

## 4. Operation of systems and equipment

### Rear center console armrest \*

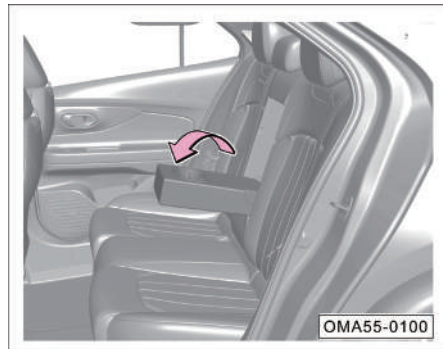

- Turn down the central armrest forward to use it.

#### **i** NOTE

The central armrest shall not be seated by anyone, and shall return to the seat back if the rear middle seat needs to be occupied.

### 4.4.4 Storage facilities

#### Storage compartment on door interior trim panel

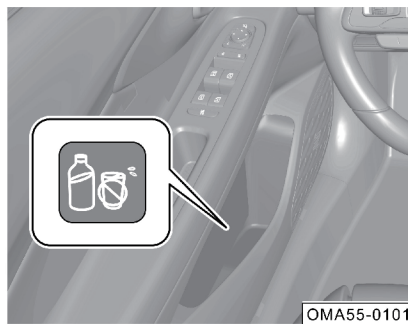

- Place beverage bottles, map manuals and other articles here.

### Instrument panel front storage compartment

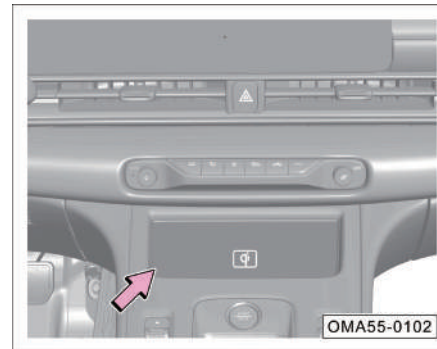

- Place small articles here.

#### **i** NOTE

For models equipped with mobile phone wireless charging function, this area is used as the mobile phone wireless charging area, so be sure to deactivate the mobile phone wireless charging function before placing articles in it. => See page 122

## 4. Operation of systems and equipment

### Instrument panel lower storage compartment

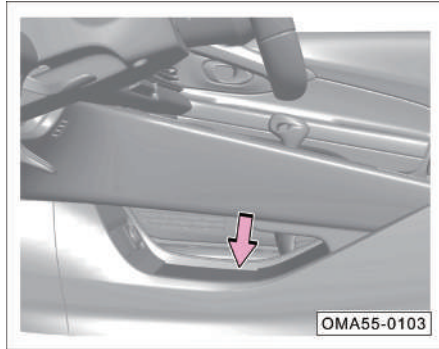

- For placing books, ipad, etc.

### Cup holder

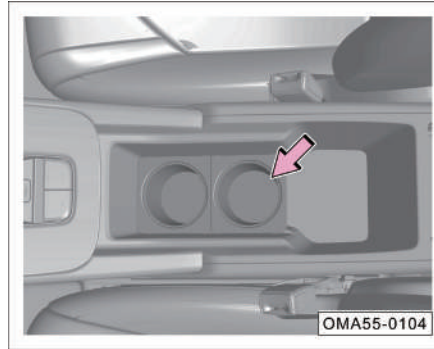

- Front cup holder: For placing beverage bottles, water cup, etc.

#### **i** NOTE

The front cup holder should be kept stable when holding the beverage, so as to ensure that it will not splash near the key to prevent damage to internal electronics.

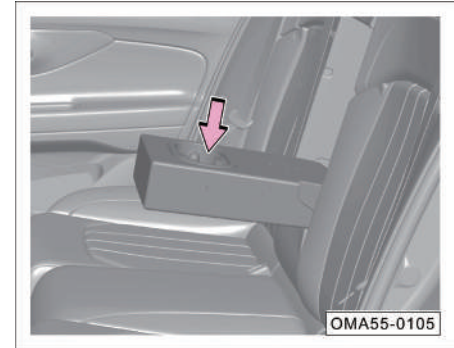

- Rear cup holder\* : Rear cup holder: Turn down the central armrest forward and then place beverage bottles.

#### **⚠** WARNING

**Do not place hot beverages on the cup holder, or hot beverages may spill out while driving, scalding the driver.**

## 4. Operation of systems and equipment

Front passenger's glove box

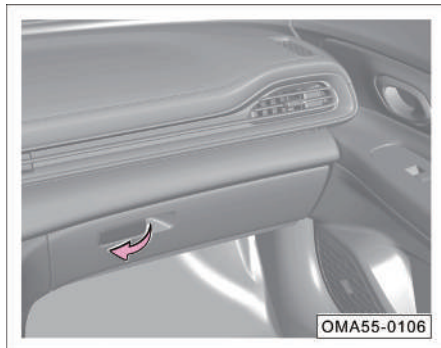

- Pull the handle to open the glove box and place articles such as file bags.
- Push back to close the glove box until a “click” is heard.

 **WARNING**

**The glove box must be closed when the vehicle is traveling, otherwise the articles in the glove box may fly out and cause personal injury to the occupants in case of an emergency braking or an accident.**

Front central armrest box

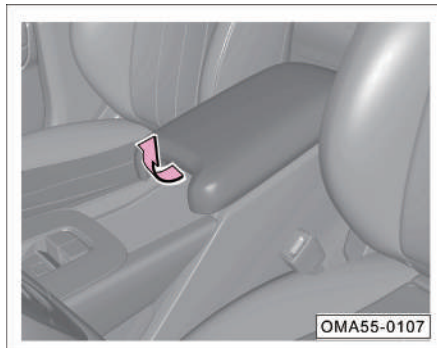

- Open the front seat central armrest box cover upward to place items such as wallets.

Storage bag on the back of front seat

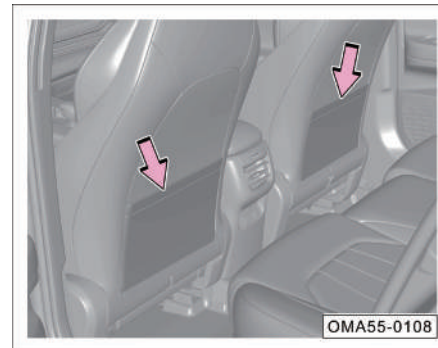

- Pull open the storage bag to put books, foldable umbrellas and other articles in it.

## 4. Operation of systems and equipment

### 4.4.5 Low battery reminder

#### Function description:

The vehicle continuously monitors the battery condition. When the low battery is detected, there will be a risk of power loss in the vehicle. Users will be reminded, through multimedia display, instrument cluster, APP and SMS, to start the engine to charge the battery, so as to improve the starting performance of the vehicle and extend the service life of the battery.

#### **i** NOTE

- The low battery reminder only reminds the low battery state, which does not mean that the battery is damaged.
- The low battery reminder function does not prevent the vehicle from running out of charge, so it still requires the user to start the engine and charge the battery in time.
- The use of incompatible batteries or the unauthorized disassembly and modification of vehicle electrical equipment may lead to the false triggering or failure of the low battery reminder function.

#### Information to be know:

When the engine is not started, due to the inability of charging, the use of vehicle electrical equipment (such as radio, lights, etc.) will directly consume the battery power, and the battery power will rapidly reduce. If the vehicle electrical equipment needs to be used for a long time, the engine should be started at the same time.

For short-distance driving, due to the short battery charging time, it is recommended that you keep the engine on and continue for a period of time.

If your vehicle is parked for a long time, start the vehicle engine regularly and keep running for a period of time to charge the battery.

### 4.4.6 USB interface/power outlet

#### Front power outlet

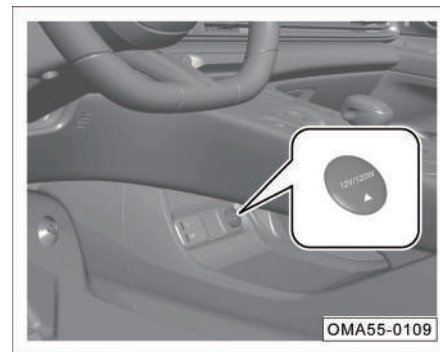

- With the vehicle power switch in the “ACC” or “ON” position, after the rear power outlet cover plate is opened, a device to be charged can be connected.

#### **i** NOTE

Devices of 12V/120W or below supported.

## 4. Operation of systems and equipment

### Front USB port

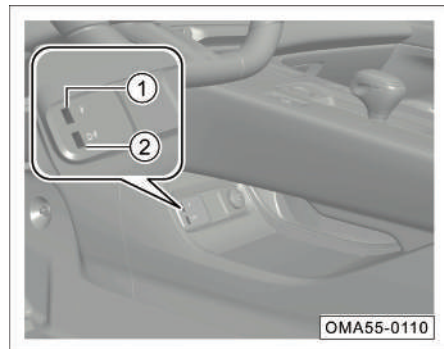

- With the ignition in the “ACC” or “ON” position, a mobile device can be connected directly for use.

#### **i** NOTE

- USB1 interface ① supports the charging and media source playback.
- USB2 interface ② supports the charging, media source playback and OTG functions.

### Rear USB interface \*



- With the ignition in the “ACC” or “ON” position, a device to be charged can be connected directly for charging.

#### **i** NOTE

The rear USB interface is for charging only.

### USB interface at interior rearview mirror \*

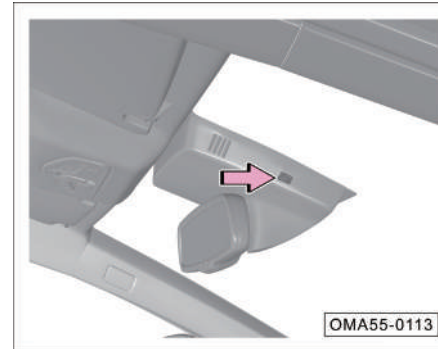

- With the ignition in the “ACC” or “ON” position, a device can be connected directly for use.

#### **i** NOTE

The USB interface of interior rearview mirror is mainly used for DVR power supply.

### CAUTION

- To avoid damage to the electrical system of the vehicle, never connect power generation equipment to a power outlet.
- Only use electrical equipment that complies with national electromagnetic compatibility regulations.
- Before turning on or off the vehicle power supply, always disconnect the device connected to the power outlet to avoid damage to the electrical equipment due to voltage fluctuations.

### WARNING

- **Never use the power outlet when nobody is in the vehicle. Improper use of the power outlet may easily cause a fire.**
- **Do not let children use the power outlet.**
- **Never use the high-power electrical equipment.**

### 4.4.7 Mobile phone wireless charging system\*

The mobile phone wireless charging system utilizes electromagnetic induction to realize the charging of the mobile phone without the need for wire connections.

### CAUTION

The mobile phone wireless charging system is only suitable for the Qi-certified mobile phones. GAC will not assume liabilities and losses for any accident caused by the use of mobile phones or other wireless charging receivers that have not passed the "Qi" certification.

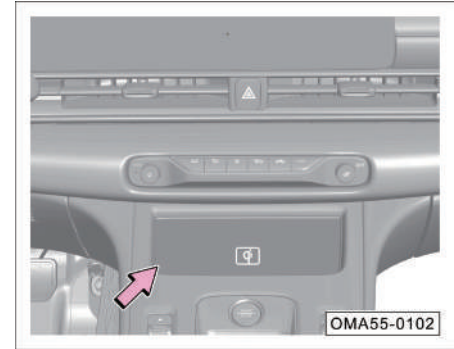

The wireless charging effective zone is in the storage slot in front of the shift lever. To charge the mobile phone, please align its charging coil with the "Qi" logo to ensure the normal charging.

## 4. Operation of systems and equipment

### Mobile phone wireless charging switch

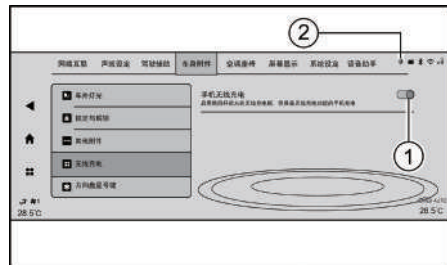

When the vehicle power switch is in the “ON” position, enter the AV system “System Settings → Body Accessories → Mobile Phone Wireless Charging”:

- Click the soft key ① to switch on or off the mobile phone wireless charging system.
- The mobile phone wireless charging function is activated by default.

### i NOTE

After the mobile phone wireless charging system is switched on, a symbol will be displayed at the position ② on the status bar of interface. The symbol status will change as the mobile phone wireless charging system is used, and if you click the symbol, the corresponding text message will pop up.

### Symbol status

Symbol	Color	Status	NOTE
	White	Standby	The mobile phone wireless charging function is activated, and please use the Qi-certified mobile phone.
	Green	Charging/ Fully charged	—
	Red	Charging failure	Please refer to table for “Mobile phone wireless charging failure & indication” table.



## 4. Operation of systems and equipment

### Mobile phone wireless charging failure

Causes	Troubleshooting
The internal temperature of the wireless charging module is too high.	The temperature is too high, so please move away the mobile phone and make another attempt later.
There are metallic foreign objects in the wireless charging module area, or the mobile phone is not centered in the wireless charging module area.	There are metallic foreign objects or the mobile phone is placed improperly, so please clear the foreign objects or adjust the position of the mobile phone.
The power supply voltage of the wireless charging module is too low or too high.	The voltage is abnormal, so please move away the mobile phone and make another attempt later.
The mobile phone request charging power is too high, or the wireless charging module transmit power is too high.	The power is abnormal, so please move away the mobile phone and make another attempt later.
The mobile phone status is abnormal.	The charging is interrupted, so please move away the mobile phone and make another attempt later.

### WARNING

- **Please do not place anything between the mobile phone and the charging pad during the charging. Non-metallic articles may cause the charging performance degradation. Magnetic cards, chip cards or other similar articles may be damaged. Metal foreign objects such as keys and coins may be heated, causing hidden driving safety hazards.**
- **To place metal foreign objects in the wireless charging zone, please first deactivate the wireless charging function through the corresponding menu on the AV system display to prevent the metal objects from sliding into the charging area and being heated during driving, which may cause hidden safety hazards.**
- **When the driver is not in the vehicle, please do not charge the mobile phone in the vehicle, so as to avoid unnecessary safety accidents.**
- **While driving a vehicle, do not check the charging status of your mobile phone for a long time, so as to avoid unexpected traffic accidents.**

### NOTE

- GAC will not assume responsibility for any problem caused by abnormal use (such as the use of external wireless charging coil); if the product is disassembled or modified without any authorization, the free warranty service will be invalidated.
- Only charge one mobile phone at a time.
- On bumpy roads, the mobile phone wireless charging function may be intermittently discontinued. If the mobile phone deviates from the charging area and its charging stops, please move the mobile phone back to the charging area.
- The effectiveness of wireless charging function depends on both the infotainment unit and the mobile phone, and if either of them is faulty, it may cause charging failure.
- The charging of the mobile phone may be discontinued when the temperature is too high, and will be continued after the temperature decreases.

## 4. Operation of systems and equipment

### CAUTION

- Do not spill water into the storage box, so as to prevent any damage to the electronic components due to water entering the wireless charging module (WCM).
- Please do not place heavy objects in the charging area to avoid damage to the mobile phone wireless charging system.
- If the product is faulty and cannot be used normally, please stop using it and go to the GAC Motor authorized shop for inspection in time.
- If there is a metal foreign object between the mobile phone and the charging area during the wireless charging, do not remove the metal object immediately by hand for fear of finger scalding, and instead, deactivate the wireless charging system and wait until the metal object cools down.

### 4.4.8 Trunk

In order to ensure the maneuvering stability of the whole vehicle, the luggage shall be placed as evenly as possible, and the heavy objects shall be placed at the front of the trunk.

### WARNING

- **The center of gravity of the vehicle carrying heavy objects may change. If heavy objects in the trunk suddenly slip, the maneuvering stability of the vehicle will change.**
- **Articles in the trunk must be fixed, otherwise they may fly forward and cause injuries to the occupants in case of emergency braking or an accident.**
- **Never place fragile, flammable and explosive articles in the trunk!**

### Objects in trunk



- There is a warning triangle in the trunk.

## 4. Operation of systems and equipment

### Models with tire vulcanizing machine\*:

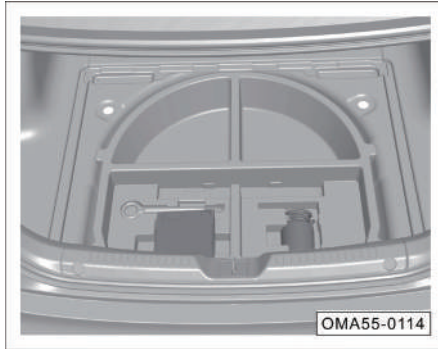

- There are inflator pump, tire sealant, towing hook, and warning triangle under the trunk carpet.

### Models with spare tire\*:



- The driver's tools and spare tire are under the trunk carpet.

## 4. Operation of systems and equipment

### 4.4.9 Accessories and modification

Data labels and signs indicating important data and information about the use of the vehicle are affixed to the fuel tank cap, engine hood latch and other components of the delivered vehicle. Do not remove or damage these labels and signs, and always keep the data and information on them legible.

The vehicle is designed with the latest safety technologies by GAC to ensure excellent active safety and passive safety. Therefore, in order to maintain the excellent characteristics of this vehicle, please be sure to consult the GAC Motor authorized shop before installing accessories or replacing parts.

It is recommended to use accessories and parts approved by GAC. Other parts than those GAC genuine parts will not be covered by the warranty.



#### WARNING

**The installation of inappropriate accessories or the modification of the vehicle may affect the maneuvering stability and other performance of the vehicle, and even may cause serious casualties.**

To install a car phone, alarm device, transceiver, low-power AV system, etc., ensure that they will not interfere with the electronic control unit such as anti-lock braking system (ABS) and the tire pressure monitoring system (TPMS) on the vehicle.

Before installing the accessories, please ensure that:

1. The accessories neither dim the lamps, nor affect the normal operation or performance of the vehicle.
2. For the vehicle equipped with side curtain airbags, the accessories must not be installed on the B-pillar or across the rear door window. Because the installation in these areas will interfere with the normal function of the side curtain airbags.



#### NOTE

When additions (such as headrest, seat cover, floor mat, sun protection mat, etc.) are required, inferior additions may contain VOCs that do not meet national standards, and may emit unusual odors, causing hidden dangers that affect the air quality in the vehicle; therefore, the genuine high-quality additions are recommended to ensure a comfortable driving environment.

### Modification of vehicle

Dismantling the parts from the vehicle or replacing the genuine parts with non-GAC Motor parts will seriously damage the maneuvering stability and reliability of the vehicle. For example:

- The installation of larger or smaller wheel and tire will interfere with the normal operation of the anti-lock braking system (ABS) and other systems.
- The modification of the steering wheel and other safety devices may cause the system failure.

#### WARNING

- **Improper modification of the vehicle or installation of inappropriate accessories may easily cause failures and accidents. The accessories and parts approved by GAC are always recommended, because the adaptability, reliability and safety of these accessories and parts have been strictly verified by GAC.**

#### WARNING

- **Improper modification or maintenance of the vehicle may weaken the protective effect of the airbag, resulting in the system failures and fatal accidents. The accessories such as beverage cup holder and mobile phone holder shall not be installed or connected to the cover of the airbag assembly or within the working range of airbags.**
- **Improper operation or modification of the vehicle (such as the modification of the engine, brake system, or components that affect the performance of the wheels and tires) will affect the SRS function, causing serious casualties.**
- **Do not install wheels and tires that are not approved by GAC.**
- **The modifications of the front and the engine compartment of the vehicle may weaken the function of the pedestrian detection system and violate road traffic regulations.**

## 4. Operation of systems and equipment

### 4.5 HVAC system

#### 4.5.1 General description

The A/C filter can filter pollen and dust entering the air inlet of A/C system.

The A/C filter must be regularly cleaned and replaced according to "Regular Maintenance Schedule" in Warranty Manual.

If the vehicle often runs in areas with poor air quality, the replacement interval of the A/C filter should be shortened. If the airflow from the A/C air outlet is not as smooth as usual, it may be due to the dirty and clogged A/C filter. In this case, clean or replace the A/C filter as soon as possible.

#### WARNING

**If the air in the vehicle is foul, it will make the driver easily fatigued, lack of energy, and distracted, which is easy to cause an accident, resulting in personal injury or even death. Therefore, enable the air circulation mode according to the actual situation.**

#### CAUTION

If the A/C system has failures (such as no cooling, odor in outlet air, etc.), please go to the GAC Motor authorized shop for inspection.

#### NOTE

- When the ignition switch is in "ON" position, the A/C system can be operated.
- When the cooling function of the A/C is turned on, there will be water dripped under the vehicle. Prolonged parking with the A/C on will cause accumulated water, which is normal.
- Regularly clean the front windshield wiper cover and remove snow, ice, and leaves to avoid clogging the A/C air intake and ensure normal air intake.
- The A/C system can achieve its maximum effect with the windows and sunroof closed. However, when the inside temperature is high under hot sun, open the windows briefly to dissipate the inside heat, and then enable the A/C for cooling.

### 4.5.2 HVAC system

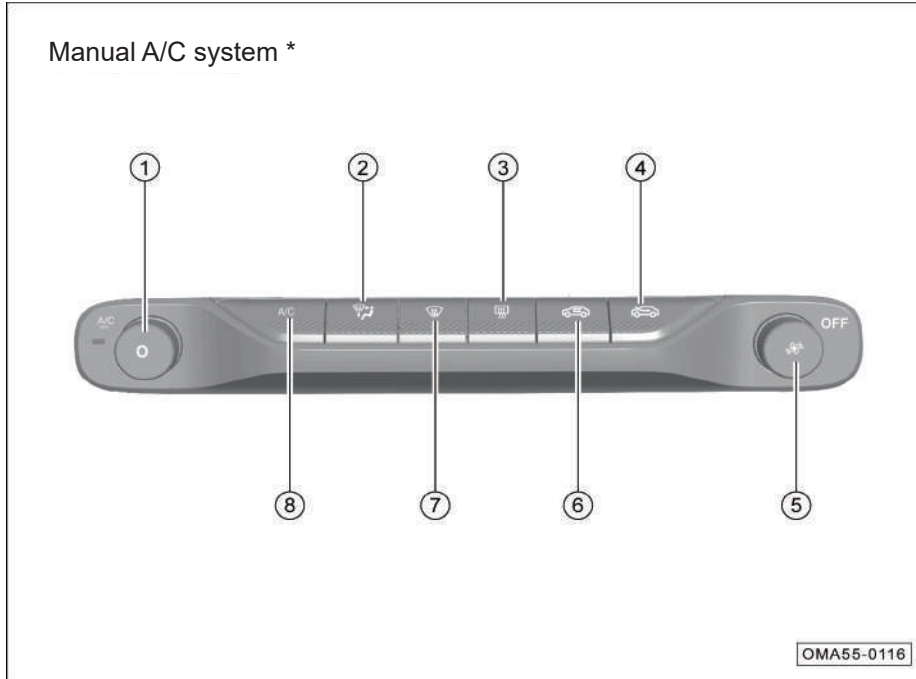

#### Manual A/C system \*







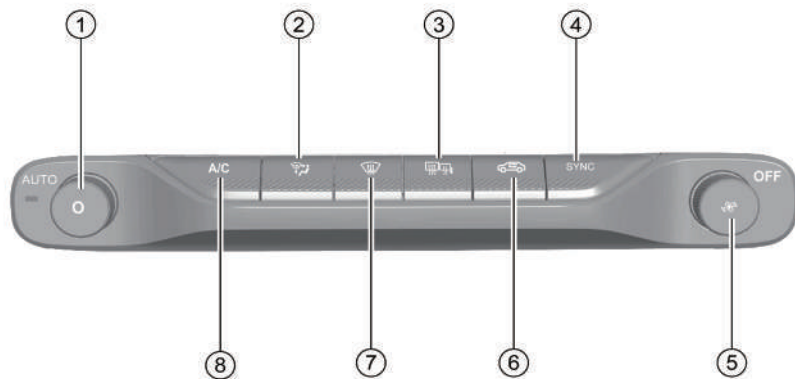

- ① ☁ Maximum cooling mode button/temperature control knob
- ② 🌬 Air supply mode button
- ③ 🚗 Rear windshield defrost/defog button
- ④ 🚗 Fresh air mode button
- ⑤ 🌀 Fan speed control knob/OFF button
- ⑥ 🚗 Recirculation mode button
- ⑦ 🚗 Front windshield defrost/defog button
- ⑧ A/C cooling button

## 4. Operation of systems and equipment

### Auto A/C system\*



### Auto A/C system\*

- ①  Automatic A/C button/temperature control knob
- ②  Air supply mode button
- ③  Rear windshield/exterior rearview mirror defrost and defog button
- ④  SYNC button
- ⑤  Fan speed control knob/OFF button
- ⑥  Recirculation/fresh air mode button
- ⑦  Front windshield defrost/defog button
- ⑧  A/C cooling button

OMA55-0259



### NOTE

- The A/C system can also be controlled by pressing the A/C information on the AV system display to switch to the A/C system control interface.
- Some functions specific to the A/C system can be set in “System Settings → AC & Seat → A/C” of AV system (for models with AVNT).
- Some functions specific to the A/C system can be set in “System Settings → AC Setting → A/C setting” of AV system (for models with AVNT).

### Temperature setting

Rotate the MAX  clockwise or counterclockwise to increase/decrease the temperature at increments of 0.5°C.

In auto mode (automatic A/C)\*, when LO/HI is displayed, the system will keep high air volume.

In auto mode (automatic A/C)\*, in order to obtain the most satisfactory inside temperature, it is recommended to set the temperature to 25.0°C, and adjust the temperature if necessary.



### A/C cooling button

Press the A/C cooling button. The button indicator lamp will come on, and the A/C system will start cooling.

Press the A/C cooling button again. The button indicator lamp will go out, and the A/C system will stop cooling.

### Auto mode (automatic A/C) \*

Press the AUTO mode button. The button indicator lamp will come on, and the A/C system will enter the auto mode.

Operate the knob  or key  to exit the A/C system automatic mode.

### Maximum cooling mode \*







- If the A/C<sub>MAX</sub> button is pressed, the button indicator lamp will come on, and the A/C system will enter the maximum cooling mode.
- If the A/C<sub>MAX</sub> button is pressed again, the button indicator lamp will go out, and the A/C system will exit the maximum cooling mode and return to the state before the maximum cooling is turned on.

### Fan speed setting

If the knob  is turned clockwise or counterclockwise, the fan speed will increase or decrease at increments of 1 level. The AV system display shows the corresponding fan speed level.

In auto mode (automatic A/C)\*, in order to make the inside temperature reach the target value, the A/C system will automatically control the fan speed. Operate the knob  to exit the automatic mode of the A/C system.

### Turning off of A/C

Press the OFF button to turn off the A/C system. After the A/C system is turned off, the button , button , button , button  /  can be effectively operated without turning on the A/C system; Operating AUTO button \*, A/C button, button A/C \*, button , temperature control knob and fan speed control knob can turn on the A/C system.

## 4. Operation of systems and equipment

### Air circulation (automatic A/C) \*

Recirculation mode

Press the button , and when the button indicator lamp is on, the air circulation enters the recirculation mode.

When the quality of outside air is poor, use this mode to prevent the outside air from entering the vehicle and recirculate the inside air.

Fresh air mode

Press the button , and when the key indicator lamp goes out, the air circulation enters into the fresh air mode.

When the quality of outside air is good, use this mode to bring the fresh outside air into the vehicle.

### Recirculation mode (manual A/C) \*

Press the button , and when the button indicator lamp is on, the air circulation will enter the recirculation mode.

When the quality of outside air is poor, use this mode to prevent the outside air from entering the vehicle and recirculate the inside air.

### Fresh air mode (manual A/C)

Press the button , and when the button indicator lamp is on, the air circulation will enter the fresh air mode.

When the quality of outside air is good, use this mode to bring the fresh outside air into the vehicle.

### CAUTION

- Long-term recirculation mode will cause accumulation of carbon dioxide in the vehicle, which is not conducive to keeping driver clearheaded.
- The recirculation mode in cold or rainy days can easily cause the windows to mist up, affecting the driver's visibility and probably causing serious accidents.

### Dual zone mode (automatic A/C) \*

Press the SYNC button, and when the button indicator lamp is on, the A/C system will enter the single zone control mode. The temperature control knob on the A/C system control panel can control the temperature on both sides of driver and passenger.

Click the SYNC button again, the button indicator lamp goes out, the air conditioner enters the dual zone control mode, and the temperature in the left and right areas is controlled independently.

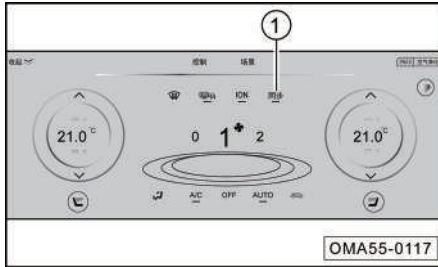

- Click "Sync" soft button ①, and the soft button indicator lamp goes out, indicating that the A/C system enters the dual zone control mode. The temperatures in the left and right zones are controlled independently.
- Click the "Sync" soft button ①, the soft button indicator lamp will be on, indicating that the A/C system exits the dual zone control mode and enters the single zone control mode, and the indoor temperature is controlled as a whole.

### Front windshield defrost/defog function

If the button  is pressed, the button indicator lamp will come on, and the front windshield defrost/defog function will be activated.



Press the button  again, the button indicator lamp will go out, the front windshield defrost/defog function will be turned off, and the state before defrosting/defogging will be restored; or press the AUTO button\* to enter the auto mode to turn off the front windshield defrost/defog function.



### CAUTION

- When the temperature is set to the lowest, the defrost/defog function will cause the outer surface of the windshield to mist up, affecting the driver's visibility and probably causing serious accidents. When using the defrost/defog function, set the temperature close to the ambient temperature outside the vehicle.
- When using the defrost/defog function, if you manually turn off the A/C cooling function, it will cause the front windshield to mist up, affecting the driver's visibility and probably causing serious accidents.
- To use the defrost and defog functions, for quick defrosting and defogging, the default air volume level is higher than 5, and the noise of the air outlet is relatively large. If you want to reduce the noise, you can manually reduce the air volume on the premise of ensuring the driver's sight.

## 4. Operation of systems and equipment

### Rear windshield defrost/defog function

If the button  /  is pressed, the button indicator lamp will come on, the rear windshield defrost/defog function will be activated, and the rear windshield and exterior rearview mirrors\* will be electrically heated.





If the button  /  is pressed again, the button indicator lamp will go out, and the rear windshield defrost/defog function will be deactivated. If you do not manually turn off the rear windshield defrost/defog function, this function will be automatically deactivated after 15 minutes.

#### NOTE

With the engine shut down, using the rear windshield defrost/defog function for a long time will cause low battery voltage, making it impossible to start the engine.

### Air supply mode

Press the button  to cycle through the following air supply modes:

-  Panel mode: Air flows out from the panel outlets.
-  panel/floor mode: Air flows out from the panel/floor outlets.
-  Floor mode: Air flows out from the floor outlets.
-  Floor/front windshield defrost/defog mode: Air flows out from the front windshield defrost/defog outlets and floor outlets.

In auto mode (automatic A/C)\*, the A/C system will automatically control the air supply mode. When the outlet air temperature is high, most of the air will be directed through the floor outlets; when the outlet air temperature is low, most of the air will be directed through the panel outlets. Press the button  to exit the auto mode of the A/C system.

#### NOTE

- In order to ensure that the A/C system can effectively control all the air supply modes automatically, please keep all air outlets open.
- Under cold start in winter, the automatic mode will control the air supply mode from the front window blowing mode to gradually transition.

## 4. Operation of systems and equipment

### Plasma purifier \*

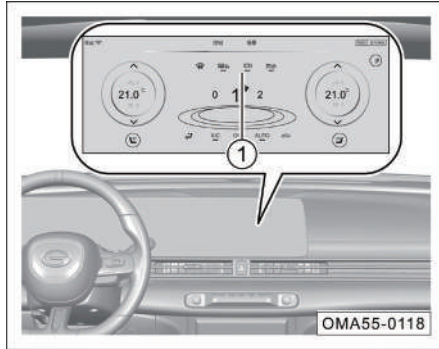

Switch AV system to the control interface of A/C system, click ION soft button ①, soft button indicator lamp will be on, and A/C system will turn on the plasma purifier. It can generate negative ions, effectively decomposing harmful gases such as formaldehyde and benzene in the car, and purifying the air in the car.

Click ION soft button ① again. The soft key indicator lamp will go out, and the A/C system will turn off the plasma purifier.

The plasma purifier function can be enabled by operating ION soft button and AUTO key.

### A/C scene\*

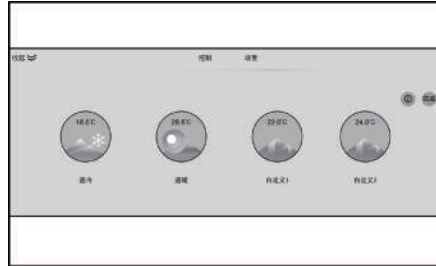

Switch the AV system to the A/C system control interface, and click “Scene” soft key to enter the A/C scene interface.

1. Preset scene 1
  - Quick cooling: 18°C, AUTO: Turn on with cold air, the air conditioning curve is fast and the temperature cools down rapidly until the target temperature is reached.
2. Preset scene 2
  - Fast warming: 28 degrees, AUTO: Turn on, the air conditioning curve is fast, and the temperature rises rapidly with maintaining the maximum power until the target temperature is reached.

### 3. Scenario customization

- The user can add the current air conditioning status or a custom air conditioning status as a custom scene if required.

## 4. Operation of systems and equipment

### 4.5.3 A/C air outlet

#### Panel side air outlet

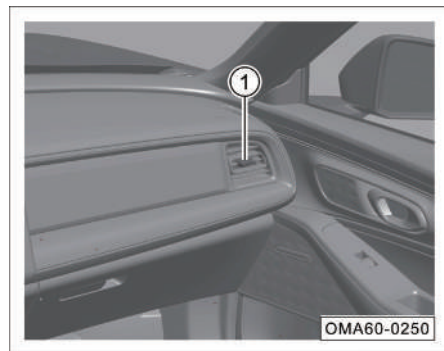

- Move the dial tongue ① up and down to adjust the longitudinal wind direction.
- Move the dial tongue left and right ① to adjust the lateral wind direction and air volume, or close the air outlet.

#### Panel central air outlet

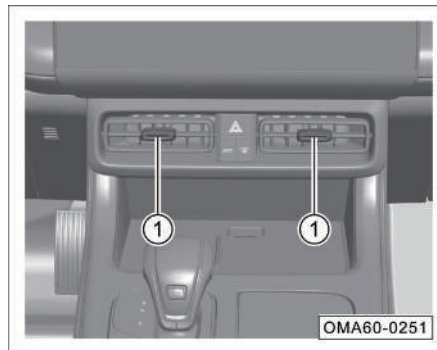

- Toggle the paddle ① up and down to adjust the air direction.
- Toggle the paddle ① left and right to adjust the fan speed, or close the air outlet.

#### Rear air outlet\*

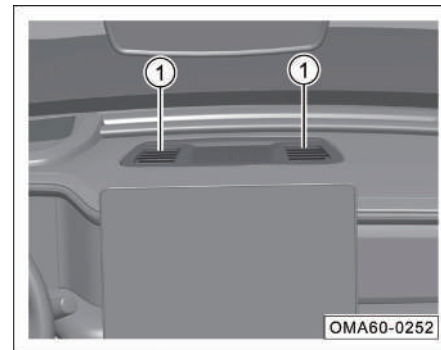

- Move the dial tongue up and down, left and right ① to adjust the wind direction.
- Turn the knob ② to adjust the air volume or close the air outlet.

### 4.6 AV system

#### 4.6.1 Console audio control button

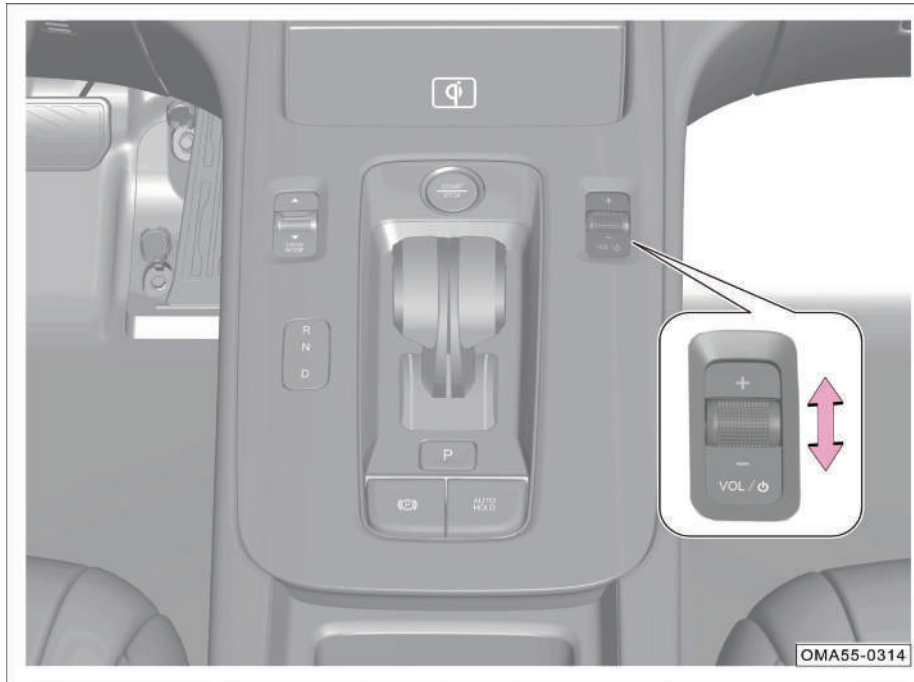

1. Volume adjustment/display OFF button
  - Vehicle power supply in the "ON" gear, the volume can be adjusted by toggling the roller up and down.
  - Press this key multi-function touch screen enter the screen saver and press this key again to cancel the screen saver.

## 4. Operation of systems and equipment

### 4.6.2 Right control button of steering wheel \*

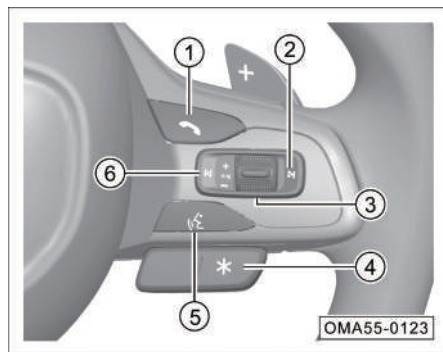

- ① **☎ Answer/hang up button of the phone**
- When there is an incoming call in the bluetooth call system, you can press the button to answer.
  - When there is an incoming call in the bluetooth call system, you can press and hold the button to hang up.
  - When there is no incoming call in the Bluetooth calling system, you can press this key to enter the Bluetooth dialing interface.
  - When there is no incoming call in the Bluetooth calling system and the bluetooth is not connected, you can press this key to enter the Bluetooth setting interface.

- ② **▶ Next song/channel switch key**
- In radio mode, press this button to automatically search for a valid station with higher frequency. If a valid station is found, the automatic search will be stopped and the station will start playing.
  - In media source playing mode, press this button to skip to the next track.
- ③ **Audio source switching button/volume adjustment button/mute key**
- Press this key continuously, switching can be done as follows: F M → A M → online radio → USB1 → USB2 → bluetooth music → online music → FM.
  - Press and hold this button to mute the media source, and then press this button to unmute the media source.
  - Toggle up/down this button to adjust the sound volume.
- ④ **\* Steering wheel custom button\***
- Press and hold or short press down the key to set related functions. For more information, refer to => [See page 139](#).
- ⑤ **Voice key**
- Short press this key to start or end local voice.

- The mobile phone is connected to the host. After the CarPlay/CarLife function is started, press this key to start or end the CarPlay/CarLife voice.
- ⑥ **◀ Previous song/channel switch key**
- In radio mode, press this button to automatically search for a valid station with lower frequency. If a valid station is found, the automatic search will be stopped and the station will start playing.
  - In media source playing mode, press this button to skip to the previous track.



### 4.6.3 Steering wheel custom button\*

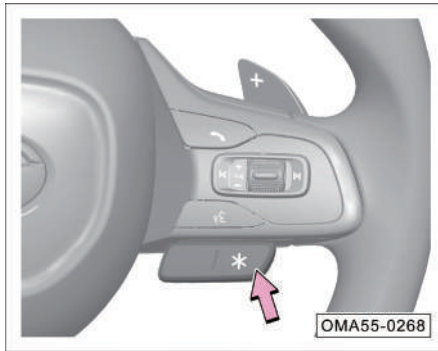

On the right side of the steering wheel, there is a button with the symbol . The button has two functional states: press and hold and press. The user can set the press and hold and press corresponding functions at the central control end of the AVN respectively.

The main functions are:

- One-click stopwatch
- Back to Main Interface
- Music
- One-click radio station
- Music fast forward
- Home
- Company
- Call
- One-click image, etc.

### Custom button setting method

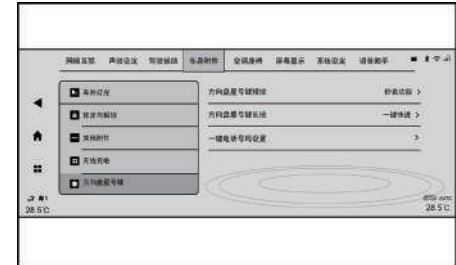

- Click "Vehicle Settings-Body Accessories-custom button" in the center console display to open the custom button settings page.
- User can set the press and press and hold functions separately.
- Before using the phone function, it is necessary to set the phone number of the contact, and make sure that the Bluetooth phone is connected.

## 4. Operation of systems and equipment

### Main function introduction and user guide

#### ① One-click stopwatch function:

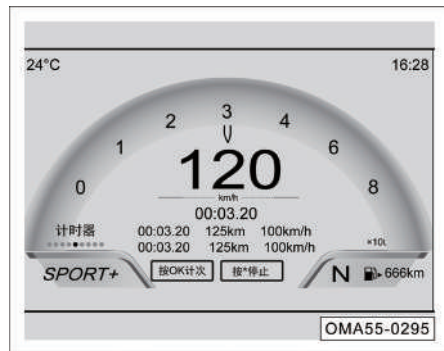

Stopwatch timing can be used to time a road section and will record the latest (last time) and shortest (best time) values in each timing result.

Operation method:

- When the custom button press function is set to stopwatch timing, the stopwatch timing function will be activated by the user by pressing the custom button.
- Press the \* key on the right side of the steering wheel to start timing according to the operation prompt on the instrument.

- Press the “OK” key on the left side of the steering wheel to count times, that is, when the timing of this circle ends, the next circle timing is started at the same time and the result will be displayed as the latest value. You can press the “OK” key multiple times to realize the timing of multiple circles.
- Press the \* key on the right side of the steering wheel to pause the timing of this lap; Press the \* key again to start a new round of timing; Or press the “OK” key to reset the stopwatch timing.
- Press the “up/down button” on the left side of the steering wheel to switch to the driving information page to exit the stopwatch timing function.

#### ② One-click music function

- The one-click music function is used to jump to music favorites and play songs from favorites.
- One-click music function. After pressing and holding or pressing the custom button, call up the user’s music favorites and play the songs in the song list; When there are no songs in favorites, call up the main music playback interface and wait for the user to play music.

#### ③ One-click radio function

- The one-click station function is used to jump to the station favorites and play the stations in the favorites.

- One-click radio station function, after pressing and holding or pressing custom button, for AVNT models, it is a one-click network radio station or local radio station function, calling up the user’s radio station favorites and playing the radio stations in the radio station list; In the AV model, it is a one-click local radio station function, which calls the local radio station and plays the favorite radio station.

#### ④ Music fast forward function

- The music fast forward function is used to fast forward the song or video through this button when listening to the song.
- When the music fast forward is set to press and hold of the custom button, press the \* key to fast forward the currently playing music or video at 2 times of the speed.

#### ⑤ One-click navigation function:

- The one-click navigation function is used to quickly use the preset destination as the navigation destination and recommend the route to start navigation.
- The one-click navigation function can be set as location points such as home and company in the navigation favorites, or users can select points on the map as the one-click navigation destination; When the custom function (press or press and hold) is set to one-click navigation, if there is no destination, the AVN will remind the user to set the destination.

### ⑥ One-button phone function

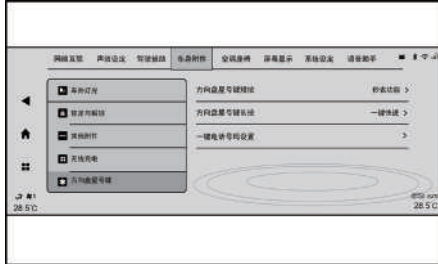

One-click phone allows you to quickly make calls to preset contacts. The procedure is as follows:

- Set the custom function to one-click phone. (Vehicle setup → body accessories → custom button → press or press and hold → one-click phone).
- Set up a contact's phone in One Touch Phone Number Settings
- Connect the Bluetooth function of the center console display to ensure that the Bluetooth phone is connected successfully.
- Press the steering wheel custom  key to make a phone call to the preset contact.

- You can hang up the phone with the "phone key" at the top of the right side of the steering wheel or the central console touch screen hang up icon.

### ⑦ AVM function:

- AVM is used to call and exit AVM on the AVN side.
- One-click image can be set on the press and hold or press operation of the custom button. When the custom button (press and hold or press) is set to one-click image function, click the key to turn on the AVM on the AVN side, and then click the key again to exit the AVM when the exit conditions are met.

### CAUTION

- The control functions of the custom buttons are adjusted according to the configuration of the vehicle (eg: One-click home requires navigation function).
- When using the one-click phone function, you need to connect the bluetooth phone and set the phone number of the contact.
- Press and hold the custom button for more than 3s to activate the function of press and hold.

### WARNING

**Please ensure the safety of the vehicle and personnel during the setting process, and try to avoid the driver operating this function while the vehicle is running to avoid traffic accidents.**

## 4. Operation of systems and equipment

### 4.6.4 Basic operations

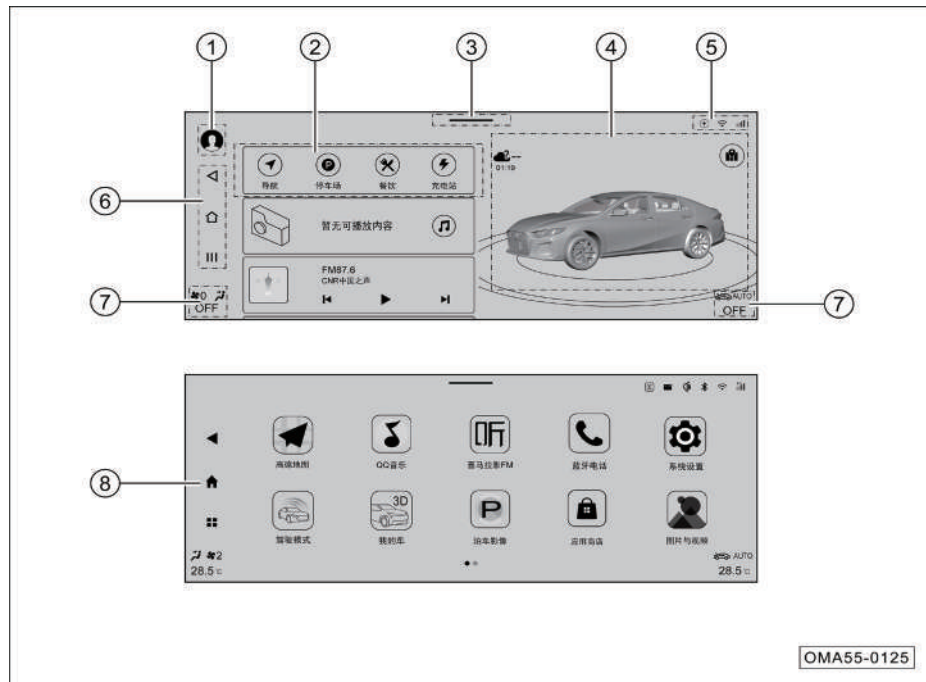

Description of AVNT main interface function area:

- ① Personal account entry
  - Click here to enter the Personal Center Settings interface.
- ② Smart card area
  - Click the cards to quickly enter the corresponding function interfaces.
  - Cards can be added and sorted in a user-defined way.
- ③ Drop-down menu area
  - Swipe down to enter the drop-down menu bar control interface.
- ④ Intelligent scenic area
  - Click the scene switch button to switch between the scene body and the scene navigation map.
  - On the scene body interface, slide left and right to drag the 3D car model to rotate, and click to enter the "My Car" application interface.
  - On the scene navigation map interface, you can perform simple operations.

## 4. Operation of systems and equipment

- ⑤ System status bar
  - System status, such as “Wireless Charging”, “Bluetooth Connection”, is displayed.
  - Click the icon to enter the corresponding function interface.
- ⑥ System navigation bar area
  - Soft keys for system control.
- ⑦ Air conditioning information display/control fence area
  - This area indicates the current A/C state. Click on here to enter the A/C control interface.
- ⑧ Application menu interface
  - Click the menu button  in the system navigation bar on the left side of the desktop to enter the application menu interface.

**i NOTE**

The AVNT unit is taken as an example in the illustration. The operation of the AV unit is similar. Please refer to the actual vehicle configuration for specific functions and interfaces.

### Time setting

- AVNT models: You do not need to set the time when the GPS is automatically refreshed.
- AV host model: Set by AV system “System Settings → System Configurations → Basic Settings → Time and Date”.

### Drop-down menu bar

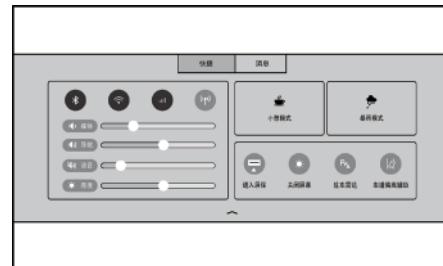

In addition to the voice and air conditioning interface, slide down from the top of the screen (drop-down bar area) to bring up the drop-down menu on any other interface. Click it  or swipe it up to hide the drop-down menu bar. In the drop-down menu bar interface, if there is no operation, the drop-down menu will be automatically hid after 20s.

Click the “Shortcut” or “Message” button to switch to the shortcut drop-down interface or the message drop-down interface.

Click any function button in the drop-down menu bar to turn on/off the corresponding function, or enter the corresponding function interface.

## 4. Operation of systems and equipment

### My Car

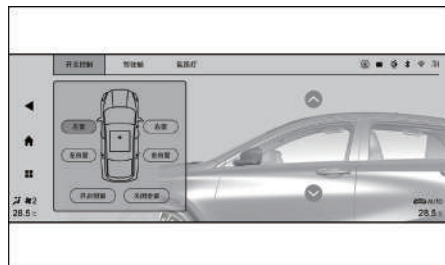

After the AV system works normally, click on the 3D car model in the smart scene area in the main interface or the “My Car” soft key in the application menu interface to enter the My Car interface.

- “Switch control (sunroof, windows)”, “seat position adjustment”, “seat heating”, “mirror adjustment” and “ambient light adjustment” can be controlled.
- Click the soft button to enter the corresponding system for adjustment.

### HICAR\*



The HiCar on-board system can realize the sharing of mobile phone calls, navigation, music and other functions between the AV system display and Huawei mobile phones.

- When you connect for the first time, you need to enter the connection code for verification. Subsequent connection needs no more entering. The connection code is displayed in the AV system display. (Click the HUAWEI HICAR soft button in the AVNT application menu to check the connection code.
- After the connection is completed, the AV system display automatically enters the main interface of the HUAWEI HiCar system.

### i NOTE

- The specific Huawei mobile phone models supported by the HUAWEI HiCar system are subject to the supported mobile phone models published on Huawei’s official website. At present, only Huawei EMUI 10.1 and above and Honor Magic UI 3.1 and above mobile phones support connection.
- When a Huawei phone uses a HICAR connection, make sure that the Bluetooth function is turned on on the phone.

## 4. Operation of systems and equipment

### CarLife\*

Via CarLife, the in-car system can share functions of mobile phones such as calls, navigation and music.

#### i NOTE

- CarLife developed a mobile phone interconnection system for Baidu, which only supports Android mobile phones 4.0 The list of mobile phones supported by the previous version and Apple 8.0 or above is subject to the latest release on Baidu's official website. The CarLife interface will be updated with the update of the APP version. The specific interface is subject to the actual version.
- If an error occurs in the interconnection of CarLife mobile phones, it is recommended to plug and unplug the mobile phone and restore the mobile phone. At the same time, it is recommended to confirm the connection. Whether the line is good or not, if there is any damage, it is recommended to replace the original cable with a new one.

#### i NOTE

- • After the mobile phone system or operating system (Android/IOS) is upgraded, CarLife functions or some functions may be unavailable. After the mobile phone system or operating system is upgraded, the original interaction protocol is changed or the version supported by the CarLife is exceeded, which affects the use of the CarLife mobile phone interconnection function.
- Due to different compatibility of CarLife with various versions of operating system of mobile phones, mobile phones with CarLife APP may not be normally connected with the in-car system. For details, please consult the mobile phone dealer.

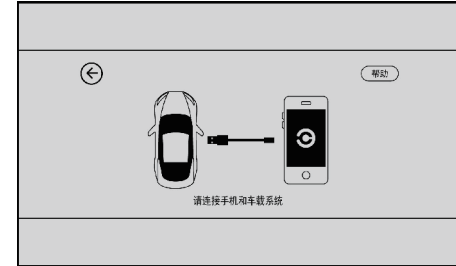

- If CarLife APP is not installed on the mobile phone, search for Baidu CarLife APP in the browser or Android app store and download it. After connecting the mobile phone to the host through the USB cable, click the “CarLife” soft button on the application menu interface.
- When the display shows the interface as shown, click “Help” to obtain connection help. You can view the detailed instructions to connection method for “Android phone” or “iPhone” according to your mobile phone.

## 4. Operation of systems and equipment

### Apple CarPlay on-board (only applicable to AV host models)

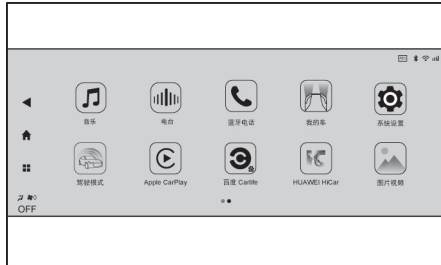

Apple CarPlay on-board allows you to navigate, make phone calls, send and receive messages and enjoy music while staying focused on driving.

- Connect the phone to the host using the USB cable. If you select CarLife, you cannot connect to the Apple Carplay.
- After the connection is successful, the system will automatically switch to the main CarPlay interface, and the CarPlay icon in the system interface will be highlighted.

- When you are in the interface of other function, you can enter the Apple CarPlay on-board system by clicking the CarPlay card or the Apple Carplay icon in the app menu.

### i NOTE

- The functions and applications supported by CarPlay are subject to those published on Apple's official website. According to the information released by Apple in 2019, Apple CarPlay supports Apple phones whose model is at least iPhone5.
- When using the CarPlay, please make sure that the CarPlay function in iPhone settings → general → access restriction is turned on, otherwise, the iPhone will only be used as an iPod and Apple CarPlay cannot be used.
- Please use the genuine iPhone data cable, otherwise connection failure may occur.

### Voice

After the AV system is turned on and works normally, wake up the voice recognition engine in the following ways before issuing a voice command to the voice recognition engine that needs to be waken up:

- Press the  button on the right side of the steering wheel to start the voice engine.
- Click the voice image in the "Voice card" in the main interface and the "Voice" icon in the application menu interface to start the voice recognition engine.
- Wake-up word: The default wake-up word is "Hello, Xiaoqi", and the other wake-up word can be defined by yourself.

There are two methods to define:

1. Wake up the voice assistant by saying "Hello, Xiao Qi", and then say "Give you a name XXX" to complete the setting of the second voice wake-up word.
2. The user can set the voice function through System Settings → Voice Assistant.



After the voice system is woken up, voice control can be performed only after the voice assistant feedback “please speak” is heard, and the system displays the listening status.

### i NOTE

The success rate of speech recognition is affected by objective factors, such as environmental noise, network signals, and subjective factors, such as usage habits and pronunciation. Please refer to the actual use effect.

### Voice settings\*



Enter the “Voice Assistant” interface to set the voice function.

1. Wake-up-free duration
  - The duration can be set to 15s/ 30s/ 60s/ 90s.
2. Customization - change the wake-up word
  - You can change the wake-up word of the voice assistant according to your own habits and preferences. After the wake-up word is customized, you can still wake up the voice recognition engine through “Hello, Xiaoqi”.

## 4. Operation of systems and equipment

### 4.6.5 Personal account\*

#### Identification for activation



When using the unit for the first time, the user needs to perform owner identification to activate the unit (this interface cannot be skipped and the user cannot operate the unit before activation).

Step 1: Scan the QR code or download the <GAC Motor> APP from the APP store.

Step 2: Register your account on the <GAC Motor> APP.

Step 3: Enter the vehicle information on the <GAC Motor> APP and scan the QR code for activation. After the owner is authenticated, the owner's account login is automatically completed and the main page is entered.

#### Account login

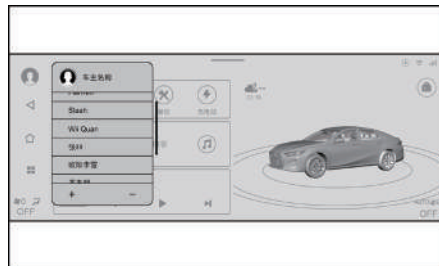

On the homepage, click the avatar in the upper left corner. The account list interface will pop up. Select the avatar of the account to log in or add a new account to log in. After you register your account on the <GAC Motor> APP, you can log in.

- Select Scan Code Login or Verification Code Login to login.

#### Logout

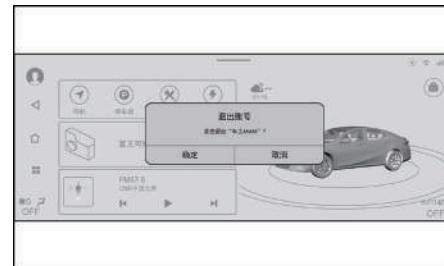

On the Personal Center page, click Exit Login and select OK to exit the current account.

## 4. Operation of systems and equipment

### Mobile data query

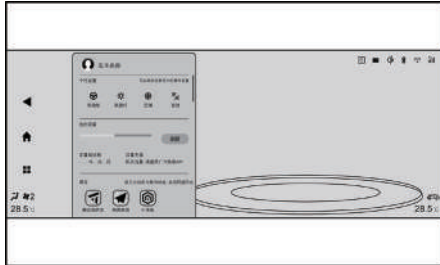

You can purchase traffic in the “My Traffic” section on the Personal Center page.

### Personalization settings

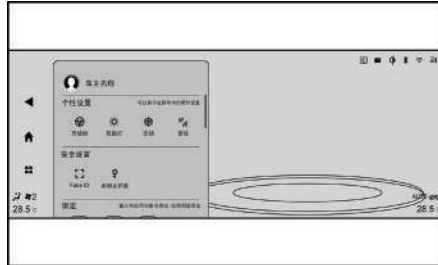

In the “Personality Settings” area, you can click to select “Cockpit”, “Ambient Light”, “Air Conditioning” and “Sound Effect” to enter the corresponding personalized settings interface and save the settings to the current account.

### Face Recognition



Click “Face ID” in the Personal Center to enter the face ID register interface, and the user can register the face ID according to the prompts.

## 4. Operation of systems and equipment

### Bind key



The user clicks the “Binding Key” soft button in the personal center, connects the account ID with the physical key after binding, and uses the key to approach the unlocked vehicle to perform personalized welcome and automatically log in to the bound account.

- The interface prompts the user to press the “unlock button” of the physical key.
- If the physical key unlock signal is detected within 30 s, it indicates that the binding is successful.
- If the physical key unlock signal is not detected within 30 s, it indicates that the binding fails, and the interface prompts that no signal is detected and please try again.

### Unbind key

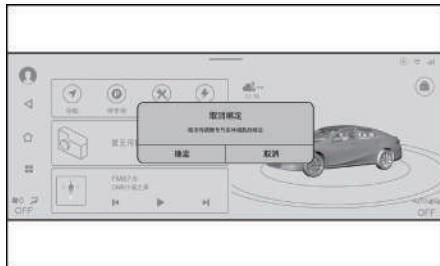

Users click the “Unbind” soft button in the personal center, and then click the “OK” soft button to release the association between the key and the account.

### Seat/rearview mirror position preservation

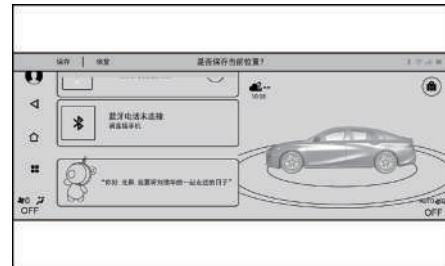

After the user logs in the account, if the user manually adjusts the position of the seat or rearview mirror, a pop-up window will prompt the user to save the adjusted position (only for models with the seat/rearview mirror memory function).

- The user can click “Save” to save the adjusted position in the current account.
- The user can click “Restore” to restore the seat to the position before adjustment.
- If there is no operation within 5 s, the account will not remember the position after adjustment.

### Bind third-party service

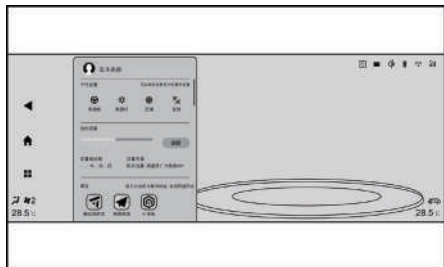

On the Personal Center page, users can click and choose to bind their personal accounts of “Tencent My Car”, “QQ Music”, “Himalaya”, and “Amap” to the current AVN account.

After binding, the user data and usage habits in the above APP are automatically synchronized.

### 4.6.6 OTA upgrade \*

Enter the system upgrade interface by pressing the “System Upgrade” soft key on the smart card on the main interface.

#### Upgrade reminder

Available update reminder

- Click “System Upgrade” to open the system upgrade window; if the system is currently the latest version, “This system is currently the latest version” will be displayed.
- When an upgrade is available, an upgrade prompt window will pop up automatically when the ENGINE START/STOP button is set to “OFF”.

Interface reminder display

- When the system detects a new version, the “System Settings” will show an update mark.
- Click this mark to enter “System Settings”. When there is a new version, the page “System Information” will show an update mark.

### Update operation

Update now

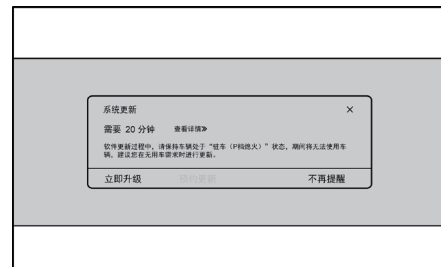

Click “upgrade now” to complete the upgrade confirmation and enter the upgrade countdown. At this time, leave the vehicle and turn it off and lock the vehicle. After the countdown, the upgrade will be automatically started.

## 4. Operation of systems and equipment

### Upgrade process



- During the official upgrade, 90S countdown interface will prompt the user to turn off the power of the vehicle, leave and lock the vehicle. You can cancel the upgrade by using the Exit Upgrade button before the countdown ends; The upgrade starts at the end of the countdown.
- If the vehicle does not meet the upgrade conditions (for example, the vehicle is not locked, the vehicle is not in OFF gear, and the power is low), the user is prompted that the upgrade conditions are not met. If the upgrade conditions are met, the update process starts. Once the update process starts, the update process cannot be interrupted and exits.

- Once the upgrade process starts, the vehicle will enter a black screen and mute state, and the vehicle start button, doors, windows and other functions may fail, and will automatically resume after the upgrade is completed.

### Upgrade process description

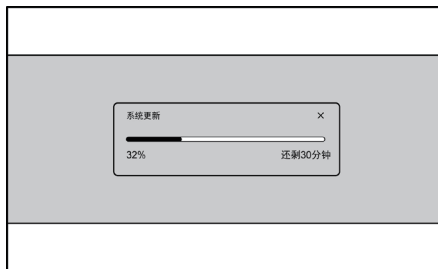

- When the display is on during the upgrade process, the upgrade progress and estimated time will be displayed.

### Upgrade result prompt

#### Successful update

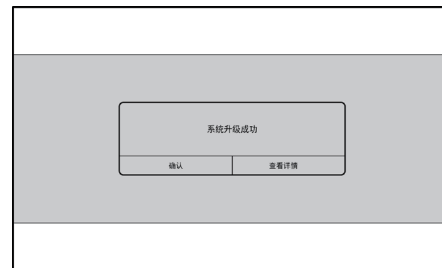

If the upgrade is successful, the "Upgrade Succeeded" window will pop up. Click "View Details" to view the information of the current version and updated contents.

### Upgrade failure



If the upgrade fails, an upgrade failure pop-up window will appear. Please contact the GAC Motor authorized shop for maintenance in time.

### **i** NOTE

- Please follow the instructions to make upgrade when the engine is shut down and locked, and no person is in the vehicle.
- Please be patient during the upgrade process and do not operate the vehicle before the upgrade is completed.
- During the upgrade process, vehicle functions will be temporarily unavailable.
- In order to ensure safety, please do not forcibly drive the vehicle or disconnect the battery and carry out other improper operations during the upgrade.
- If you encounter upgrade-related problems, please contact the GAC Motor authorized shop or call the service hotline. Line: 400-813-6666.

## 4. Operation of systems and equipment

### 4.6.7 Radio

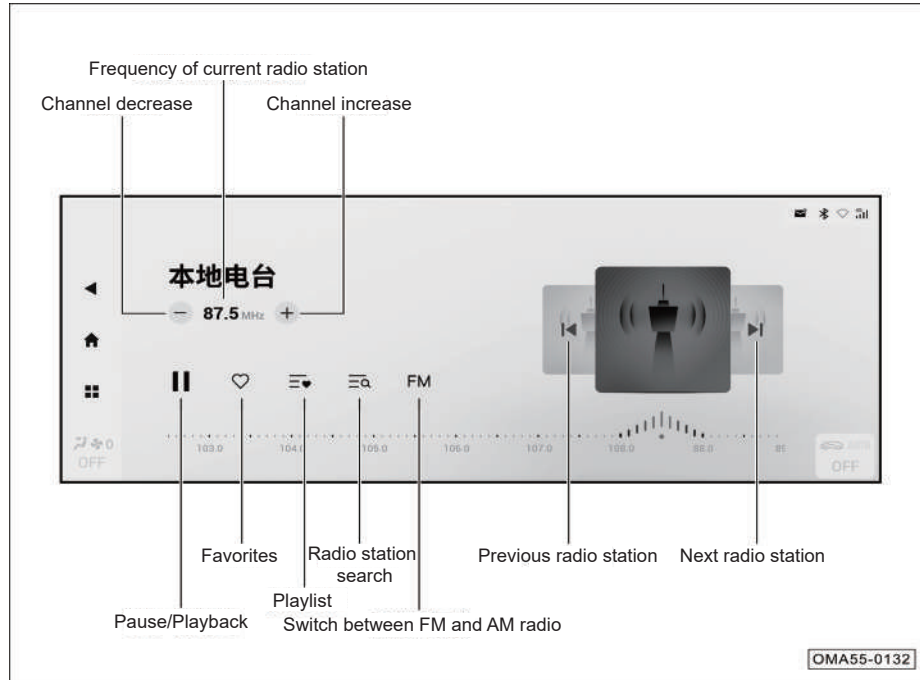

Enter the Radio interface in the following ways:

- Click the "Radio" card in the main interface to enter the radio mode.
- Press the button on the right side of the steering wheel repeatedly to switch to the radio mode.
- Click "Local Station" soft button through the application menu interface to enter the radio playback interface.

#### **i** NOTE

The radio station is divided into two modes: local radio and online radio. Only local radio is described here.



## 4. Operation of systems and equipment

### 4.6.8 Local music

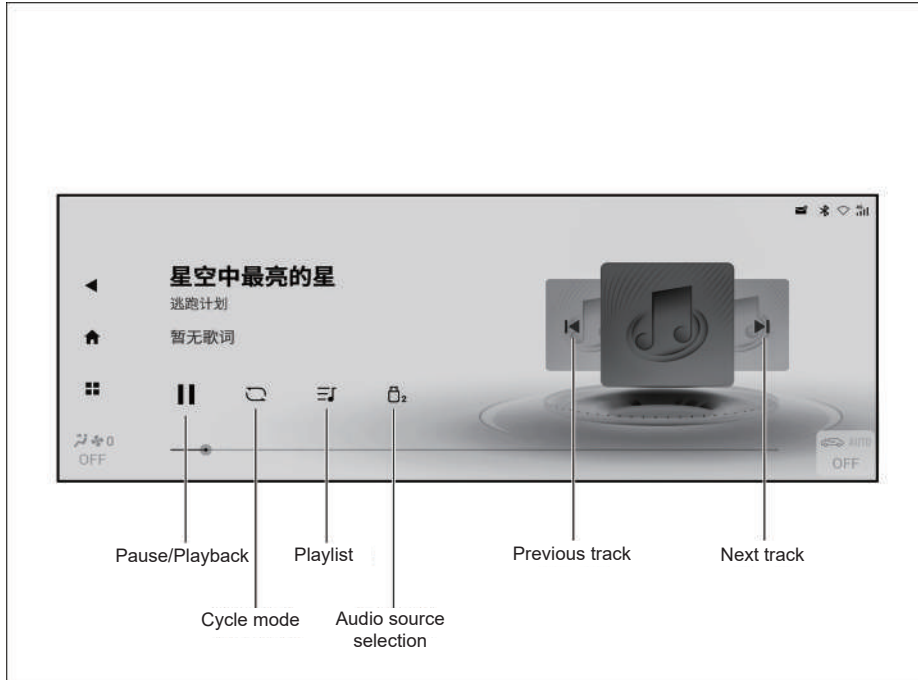

Enter the local music playback interface in the following ways:

- Click the “Music” card in the main interface to enter the local music interface.
- Press the button on the right side of the steering wheel repeatedly to switch to the local music interface.
- Click the “Local Music” soft key in the application menu interface to enter the local music interface.



#### **i** NOTE

- In case of online music, click “Music” card in the main interface to enter the online music playback interface, and not to enter the local music interface.
- The AVNT unit music application has two functions of “online music and local music”, and only local music function will be described herein.
- AV system only supports USB devices of FAT16/32.

## 4. Operation of systems and equipment

### 4.6.9 Bluetooth function

Enter the Bluetooth mode in the following ways:

- Click the “Bluetooth phone” soft key in the application menu interface to enter the Bluetooth mode.
- In non-call mode, press the  button on the right side of steering wheel to enter the Bluetooth mode.
- Click the soft key in the drop-down menu  to enter the Bluetooth mode.

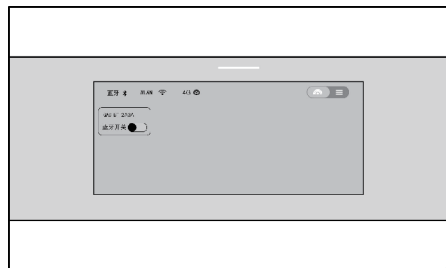

- If there is no Bluetooth device connected, use the above method to enter the Bluetooth Settings interface.

- After turning on the Bluetooth function by clicking the “Bluetooth ON/OFF” soft key , the IHU will automatically search for nearby Bluetooth devices. The Bluetooth connection interface displays two display modes: “Radar” and “List”.

#### Radar display mode



- Bluetooth devices: Display the names of nearby Bluetooth devices that can be connected, select the devices to be connected, and click to connect to Bluetooth.
- Switch the list display mode: Click  soft button to switch to the list mode, the list mode displayed. The number is the number of Bluetooth devices that can be connected to the periphery.

#### List display mode

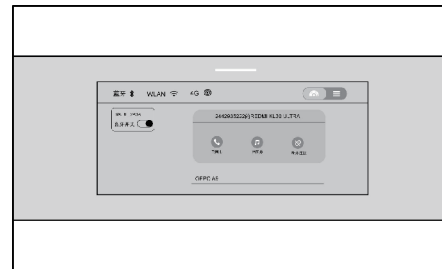
- Bluetooth device: Displays the Bluetooth devices that can be connected to the periphery and displays them in a list style.
- Switch the radar display mode: Click  soft button switch to the list mode to display the number of Bluetooth devices that can be connected to the periphery.



After the Bluetooth connection, the status bar icon will be highlighted, and the connected Bluetooth device name will be displayed on the Bluetooth connection interface:

- Click the  soft key to synchronize phone numbers, contacts and other information.
- Click the  soft key to synchronize the song name, lyrics and other information of Bluetooth music.
- Click the  soft key again to disconnect the Bluetooth.

### **i NOTE**

The AVNT unit is taken as an example in the illustration. The operation of the AV unit is similar. Please refer to the actual vehicle configuration for specific functions and interfaces.

### **Bluetooth connection failure**

Possible cause	Action
The device's Bluetooth function is set incorrectly	Set the device's Bluetooth so that it can be "Visible to Everyone" or can be searched or opened for detection
The current device is not compatible with the in-car Bluetooth system	Confirm the compatibility of the device with the Bluetooth version, update the operating system of the mobile phone to the latest version and try again
The mobile phone's Bluetooth was connected to other devices	It is recommended to delete the Bluetooth devices that were connected

## 4. Operation of systems and equipment

### 4.6.10 System settings (applicable to the vehicle models with AV host)

Click "System Settings" in the more menu interface to enter the system settings interface. In the settings interface, click on an option to select it, click on the slider  to enable or disable the function, and drag the progress bar for adjustment.

Settings group	Function	Function	Options
Device connection	Bluetooth	Bluetooth Name	/
		Bluetooth switch	On/Off
		Auto connection	On/Off
		Automatically Sync Contacts	On/Off
	List of paired devices	/	
	Device list	HUAWEI HICAR device	Add a new device
Sound Settings	System sound effect	Media Volume	/
		Call volume	/
		DTS sound effect settings	Off/driver/all passengers
		Sound effect mode	Natural soundtrack/Clear life/Subwoofer/Nap mode
		Speed-sensitive volume control	Not sensitive/Weakly sensitive/Generally sensitive/ Strongly sensitive
		Turn on volume	Unchanged/Adaptive
		Unlock tone	On/Off
		Driving assist chime and media sound	Mute/Remain unchanged
		Pre-setting sound effects	Classic/Pop/Jazz/Rock/Default/Custom
	Sound field	Reset	
	Interactive sound effect	Touch tone	Modern/retro/off
		Interface sound effect	On/Off

## 4. Operation of systems and equipment

Settings group	Function	Function	Options
Driving assistance	Driving tips and memories	Safe speed reminder	Range: 0~200
		Current driving mode memory	On/Off
	Longitudinal vehicle control assist	Speed limit sign identification*	On/Off
		Intelligent speed limit*	On/Off
		Forward collision warning*	On/Off
		FCW distance*	Far/medium/near
		Active brake assist*	On/Off
	Lateral vehicle control assist	LKA*	On/Off
		LKA mode*	On/Off
		Emergency lane keeping *	On/Off
	APA	Parking assist chime	On/Off

## 4. Operation of systems and equipment

Settings group	Function	Function	Options
Body Accessories	Exterior Light	Intelligent high beam*	On/Off
	Lock/Unlock	Intelligent active lock	On/Off
		Intelligent active unlock	On/Off
		Vehicle speed lock	On/Off
		Trunk lid easy open*	Off/on/prompt sound on
		Automatic wiper function*	On/Off
	Other accessories	Auto folding of exterior rearview mirror*	On/Off
		Rain-sensitive window closing*	On/Off
		Automatic window closing when hirecar	On/Off
		ETC*	On/Off
	Asterisk key * on the square panel	Pressing of steering wheel button	One-click stopwatch/one-click play of favorite online music/one-click play of favorite local radio/one-click play of favorite online radio/one-click home/one-click company/one-click phone/one-click video
		Pressing and holding of steering wheel button	One-click stopwatch/one-click play of favorite online music/one-click play of favorite local radio/one-click play of favorite online radio/one-click home/one-click company/one-click phone/one-click video
		One-touch phone number setting	/

## 4. Operation of systems and equipment

Settings group	Function	Function	Options
Air conditioning setting	A/C	Intelligent control of recirculation/fresh air mode	On/Off
		Maximum air volume under the automatic mode	On/Off
		Sensitivity adjustment of air quality intelligent control	On/Off
		Unlock ventilation	On/Off
		A/C self-drying	On/Off
Screen Display	Center console	Center console display brightness	Range: 0~100
		A/C interface hold time	5s/10s/15s/30s
	Instrument	Instrument volume	Low/medium/high
		Fuel consumption/mileage	Km, L/100km or km, km/L or mpg, mi or mpg
		Unit of measurement of temperature	°C/°F
		Unit of measurement of pressure	kPa/bar/psi
		Backlight of instrument panel	Range: 0~8
		Rear seat belt reminder	On/Off
		Reset maintenance reminder	Reset
		Maintenance reminder intervals	5000km/7500km/10000km
		Repeated reminder	On/Off
Default setting	Reset		

## 4. Operation of systems and equipment

---

Settings group	Function	Function	Options
System Settings	Basic settings	Time and date	Setting
		24-hour system	/
	System information	Hardware version	/
		Software version	/
		Current language	Chinese
		Supported languages	Chinese
		Factory reset	Reset
	Vehicle Information	Manufacturer	/
		Model	/
		S/N	/
		Hardware version	/
		Current language	Chinese/English
		Supported languages	Chinese/English



## 4. Operation of systems and equipment

### 4.6.11 System setting (applicable for AVNT models)

Click the “System Setting” soft button in the application menu interface to enter the system setting interface. In the settings interface, click on an option to select it, click on the slider  to enable or disable the function, and drag the progress bar for adjustment.

Settings group	Function	Function	Options
Internet	Bluetooth	Bluetooth Name	/
		Bluetooth switch	On/Off
		Auto connection	On/Off
		Automatically Sync Contacts	/
		List of Connectable Devices	/
	Network and Hotspot	Mobile networks	On/Off
		Mobile hotspot	On/Off
		Restart the on-board communication module	Restart
	WLAN	WLAN On/Off	On/Off
		List of connectable networks	/

## 4. Operation of systems and equipment

Settings group	Function	Function	Options
Sound Settings	System sound effect	Multimedia volume	Range: 0~39
		Bluetooth phone volume	Range: 0~10
		Intelligent voice volume	Range: 0~10
		Navigation broadcast volume	Range: 0~10
		3D sound effect settings	Off/Driver/All occupants
		Sound effect mode	Natural sound/clear voice/super bass/rest
		Sound field *	Reset
		Speed-sensitive volume control	Not sensitive/Weakly sensitive/Generally sensitive/ Strongly sensitive
		Startup volume	Adaptive/Invariant
		Driving assist chime and media sound	Unchanged/Mute
	Interactive sound effect	Unlock/lock prompt sound	On/Off
		Touch tone	Modern/retro/off
		Interface sound effect	On/Off
		Driving mode switching tone	Sprint/chase

## 4. Operation of systems and equipment

Settings group	Function	Function	Options
Driving assistance	Driving tips and memories	Safe speed reminder	Range: OFF~200
		Current driving mode memory	On/Off
	Longitudinal driving assistance *	TSR	On/Off
		Electronic eye overspeed alarm sound *	On/Off
		Intelligent speed limit*	On/Off
		FCW	On/Off
		Forward collision warning distance setting	Far/medium/near
		Active brake assist	On/Off
	Lateral driving assistance *	Lane Keep Assist	On/Off
		LKA mode	Steering /Warning/Steering and warning
	Blind area driving assistance *	BSD*	On/Off
		Door opening warning*	On/Off
		Rear approach alert system *	On/Off
	APA	Parking assist chime	On/Off

## 4. Operation of systems and equipment

Settings group	Function	Function	Options
Body Accessories	Exterior Light *	Intelligent high beam	On/Off
	Lock/Unlock	Remote unlock	All doors/Driver's door only
		Auto unlock	On/Off
		Vehicle speed lock	On/Off
		Intelligent active lock	On/Off
		Intelligent active unlock	On/Off
		Trunk lid easy open*	Close/only open/prompt tone
	Other accessories	Auto folding of exterior rearview mirror*	On/Off
		Turning down of exterior rearview mirror when reversing*	On/Off
		Automatic wiper function*	On/Off
		Automatic window closing when hirecar	On/Off
		Rain-sensitive window closing*	On/Off
		ETC*	On/Off
	Wireless charging*	Mobile phone wireless charging	On/Off
	Buttons on steering wheel*	Pressing of steering wheel button	One-click stopwatch/one-click play of favorite online music/one-click play of favorite local radio/one-click play of favorite online radio/one-click home/one-click company/one-click phone/one-click video
Pressing and holding of steering wheel button		One-click stopwatch/one-click play of favorite online music/one-click play of favorite local radio/one-click play of favorite online radio/one-click home/one-click company/one-click phone/one-click video	
One-touch phone number setting		/	

## 4. Operation of systems and equipment

Settings group	Function	Function	Options
A/C & Seat	A/C	Intelligent control of recirculation/fresh air mode	/
		Maximum air volume under the automatic mode	Low/medium/high
		Unlock ventilation	On/Off
		A/C self-drying	On/Off
	Seat	Convenient for driver to enter and exit	On/Off
Screen Display	Console display	Center console display brightness	Range: 0~100
		A/C interface hold time	5s/10s/15s/30s
		Intelligent scene switching	Automatic/manual switching
	Instrument display	Instrument volume	Low/medium/high
		Fuel consumption/mileage	Km, L/100km or km, km/L or mpg, mi or mpg
		Unit of measurement of temperature	°C/°F
		Unit of measurement of pressure	kPa/bar/psi
		Backlight of instrument panel	Range: 0~8
		Rear seat belt reminder	On/Off
		Reset maintenance settings	Reset
		Maintenance reminder intervals	5000km/7500km/10000km
		Repeated reminder	On/Off
		Default setting	Reset

## 4. Operation of systems and equipment

Settings group	Function	Function	Options
System Settings	Basic settings	24-hour system	On/Off
		Quick login	On/Off
		Message push	On/Off
	Navigation signal mode	Navigation signal mode	GPS/BeiDou/GPS+BeiDou
	System information	System version	/
		System update	Update
		Review of version features	/
		Memory size	/
		Cleanup acceleration	Activation
		Factory reset	Reset
	Vehicle Information	Manufacturer	/
		Model	/
		S/N	/
		Hardware version	/
		Current language	Chinese/English
Supported languages		Chinese/English	
Voice Assistant	Voice settings	Customized wake-up word	/
		Wake-up-free duration	15s/30s/60s/90s
		Voice wake-up	/
		Wake-free word settings	/

### 4.7 GAC Motor T-BOX\*

#### 4.7.1 General description

GAC Motor T-BOX is an intelligent in-car service system for GAC Motor series vehicles.

GAC Motor T-BOX use GAC Motor's latest generation of automotive electronic systems, which are equipped with the self-developed T-BOX equipment, using mobile communication networks and imported with professional TSP platforms. Relying on global satellite-based positioning system, car owners can enjoy security self-service, remote control, infotainment and other services in real time through emergency rescue services and <GAC Motor> mobile apps. GAC Motor T-BOX is dedicated to creating a quality intelligent vehicle for you, bringing you an intelligent, secure and enjoyable driving experience.

This section aims to introduce the GAC Motor T-BOX, so you can quickly learn about its use and operation. For further information, please read the "help center" of the <GAC Motor> mobile APP.

Before using the GAC Motor T-BOX for the first time, be sure to read the "T-BOX Service Agreement" and "Privacy Agreement" carefully to familiarize yourself with its usage and associated provisions.

If you have any questions, please consult the GAC Motor authorized shop or call the service hotline: 400-813-6666.

#### Tips

GAC Motor T-BOX will be restricted under any of the following conditions:

1. If the network service of existing communication mode (4G) cannot be provided due to termination, postponement, phasing out and other factors of the communication company, OEM does not need to bear the corresponding responsibilities.
2. The GAC Motor T-BOX terminal integrated with the electronic equipment of the vehicle has been repaired or altered without authorization.
3. Power supply to the terminal is interrupted due to natural disasters, violent impacts, etc., or power supply is unavailable due to electric leakage of the vehicle's battery.
4. The vehicle cannot be located accurately due to abnormal GPS satellite signals, external interference in the airwaves, restricted airwaves in a certain area, etc.
5. The vehicle is running in an area where GPS satellite cannot accurately locate the vehicle and other areas that cannot be covered by 4G signals, such as a place between high buildings, a tunnel and underground space.
6. All or partial services may be limited or terminated due to overhaul, replacement or malfunction of the center's system, natural disasters, national unrest, equipment failure, a dramatic increase in service usage, etc.

## 4. Operation of systems and equipment

### Communication service

Communication service is required when you use the GAC Motor T-BOX. During the experience period, the following backstage support services will be provided:

- A communication package provided by China Mobile will be available to vehicles equipped with the backstage support service system. Please consult the GAC Motor authorized shop for the details of the communication package.
- The communication package contains a certain amount of data traffic and call duration. After the set amount of the package is exceeded, some functions will be unavailable and users need to purchase new data plans at their own expense.

### CAUTION

- GAC Motor T-BOX service can provide you with remote control, remote query, safety and security. And other services, realize remote control of people and vehicles at any time and anywhere, and improve the convenience of using vehicles. Since the in-car Internet device will cause communication costs, if you don't use it for a long time, there may be a risk that your SIM card will be deactivated and your number will be canceled by the telecoms operator. To restore this function, you need to replace the components of T-BOX assembly at your own expense at a GAC Motor authorized shop. It is recommended that after purchasing the vehicle, you can open your account as soon as possible and complete real-name authentication to experience the convenient life brought about by the GAC Motor T-BOX.
- The SIM card communication function is integrated into the on-board equipment of GAC Motor T-BOX service. During the warranty period, the SIM card entertainment flow packet can be used normally. After the warranty period or basic package is exceeded, the vehicle owner scans the QR code on the <GAC Motor> mobile phone APP or AV system for purchase and renewal.

### 4.7.2 Download APP on mobile phone

#### Download APP on mobile phone



Use the mobile phone to scan the GAC Motor APP QR code to download the APP.



### 4.7.3 Emergency Rescue \*

The emergency rescue function includes automatic call after crash, roadside service and manual emergency call. Automatic call after crash will be automatically enabled by GAC Motor T-BOX under certain circumstances, while roadside service and manual emergency call need to be manually enabled by pressing the emergency call button.

Both the automatic call after crash and manual emergency call can call the emergency contact.

- Automatic call after crash: If the vehicle has an accidental collision and the airbag explodes, the GAC Motor T-BOX will start the collision automatic rescue function and automatically call the emergency contact person.
- Manual emergency call: When the automatic help-seeking function is not working, manually press the emergency contact button to start the manual emergency help-seeking function and call the emergency contact person.

Emergency call button

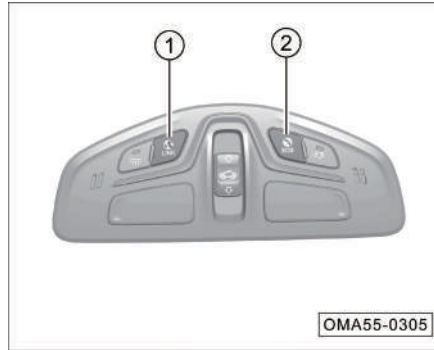

1. LINK button ①: Press and hold (3s), GAC Motor T-BOX start roadside service function, call GAC Motor authorized shop phone (written by GAC authorized shop when the vehicle is sold). After the call is answered, the rescue personnel of the GAC Motor authorized shop will provide services for you.
2. SOS button ②: Press and hold (3s), GAC Motor T-BOX start emergency call to call emergency contact.

#### i NOTE

- You can click the B- CALL icon to call the road rescue phone and start the roadside service function through the menu interface of AVNT system.
- The emergency contact phone number is that you designated when you purchase the vehicle.
- If you need to change the phone number of the emergency contact, you can change it through the GAC Motor APP or go to a GAC Motor authorized shop.

## 4. Operation of systems and equipment

### 4.7.4 Feature list

You can obtain the GAC Motor services by pressing the in-vehicle emergency call button, or using the mobile APP.

Category	Service	Description	Access method			Notification method		
			Website	APP	APP	Website	APP	Text message
Emergency rescue service	Automatic call after crash	When the airbag burst, the on-board intelligent sensing terminal will activate automatic help and the emergency contact person will be called by the button at the first time.	Auto					○
	Roadside service	If the vehicle has a problem, you can seek for roadside service from the GAC Motor authorized shop by pressing the "LINK" button.			○			○
	Manual emergency call	In case of an emergency, you can call your preset emergency contact person at the first time through the "SOS" button.			○			○
Vehicle control via mobile APP	Vehicle locating	When the vehicle is missing, you can locate the vehicle through the <GAC> APP.		○		○	○	
	Door lock/unlock via mobile APP	You can lock or unlock the doors via the GAC Motor APP.		○			○	
	Horn sounding via mobile APP	You can control the horn via the GAC Motor APP.		○			○	
	Lamp flashing via mobile APP	You can control the flashing lights of the vehicle through the GAC Motor APP.		○			○	
	Remote start/stop engine <sup>*1</sup>	You can start or shut down the engine via the GAC Motor APP.		○			○	
	Seat heating via mobile APP <sup>*1</sup>	You can heat the seats of the vehicle via the GAC Motor APP.		○			○	
	Remote enable trunk lid	You can use the <GAC Motor> APP to enable trunk lid.		○			○	
	A/C on/off via mobile APP <sup>*1</sup>	You can control the A/C, including temperature, fan speed and recirculation/fresh air mode, via the GAC Motor APP.		○			○	

## 4. Operation of systems and equipment

Category	Service	Description	Access method			Notification method		
			Website	APP	APP	Website	APP	Text message
Car care service	Vehicle condition query <sup>*1</sup>	You can use the <GAC Motor> APP to query the vehicle status in real time, including the door lock status, tire pressure status, etc.	○	○		○	○	
	Self-diagnosis <sup>*2</sup>	You can query about the vehicle conditions in real time via the GAC Motor APP which will prompt you when an abnormality occurs. The user is prompted.	○	○		○	○	
	Vehicle abnormality alarm	The in-vehicle GAC Motor T-BOX terminal monitors the vehicle conditions in real time, and uploads abnormalities if any. According to the abnormality information, specialists in GAC Motor Service Center will contact you and remind you to go to the GAC Motor authorized shop for inspection as soon as possible. Go back to the store for maintenance.		Auto		○		○
Safety and security service	Vehicle anti-theft and abnormal event alarm	<p>1. Flameout state and illegal movement of the vehicle position. In case of towing, the GAC Motor Service Center will send a text message to inform you that the vehicle has suffered illegal movement.</p> <p>2. Abnormal intrusion alarm: When the vehicle encounters intrusion when the door is locked and stalled, the GAC Motor Service Center will send a text message to inform you that the vehicle has suffered abnormal intrusion.</p>		Auto			○	

\*1: This service can be executed only when the vehicle is armed.

## 5. Driving guide

### 5.1 Starting and driving

#### 5.1.1 Door latch and inside handle



When the smart key is detected in the vehicle, the START/STOP button (START/STOP button) can be operated to switch the power state.

When the gearshift lever is in “P” gear and the brake pedal is depressed, the backlight color of START/STOP button turns green, press START/STOP button to start the engine.

When the gearshift lever is in the “P” gear and the brake pedal is not depressed, press the START/STOP button and switch in the “OFF → ACC → ON → OFF” gear sequence.

- OFF: The button backlight turns red, and the START/STOP button is switched off.
- ACC: The backlight color of the switch is orange, and accessories such as seat heating and power outlet can be used.
- ON: The backlight color of the switch is orange, the instrument cluster backlight is on, and all electrical equipment can be used.
- Successful startup: The button backlight turns red.

#### **i** NOTE

- When the START/STOP button switches from the “OFF” gear to the “ACC” gear and remains at the “ACC” gear for one hour, it will enter the power saving mode. If the switch is at “P” gear, it will automatically return to the “OFF” gear.
- If the start switch is in the “ON” gear, the transmission gearshift lever is in another gear other than the “P” gear, and the brake pedal is not pressed, press the START/STOP button, it will switch in the sequence of “ON→ACC→ON” gear without returning to “OFF” gear. For example, in the “ACC” gear, when the transmission gearshift lever switches from other gears outside the “P” gear to the “P” gear, the “OFF” gear will be automatically returned without pressing the START/STOP button.

### Limphone mode

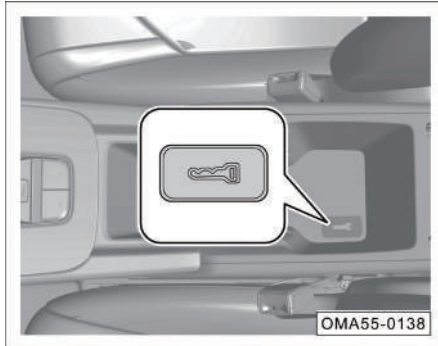

If the smart key battery is low and the instrument cluster display prompts “No key detected”, you can try to place the smart key horizontally at the key mark at the bottom of the armrest box, and then press the START/STOP button to switch to the “ACC” or “ON” gear, or press the brake pedal, START/STOP button the backlight color turns green, and press the START/STOP button to start the engine.

This method is intended for emergency start. Please replace the battery of the intelligent remote control key as soon as possible.

### 5.1.2 Start the engine

- Enter the vehicle with the intelligent remote control key.
- Make sure the gear is in “P” or “N”.
- Step on the brake pedal to ensure that the backlight color of the START/STOP button is green
- Press the ENGINE START/STOP button to start the engine.

#### **i** NOTE

In case of a cold start, run the engine at idle speed to warm up it before driving. At the same time, the valve tappet takes a few seconds to reach the normal working pressure and operation noise will occur, which is normal.

#### **👁** CAUTION

- The engine start time shall not exceed 15s. If the engine is not started successfully, you must wait about 30s before next attempt.
- Do not depress the accelerator pedal hard to make the engine run at high speed or overload after starting. Otherwise, the engine is likely to be damaged.
- If the battery level is low and the engine cannot be started, try to start it by a jumper cable. => [See page 335](#)
- It is prohibited to start the engine by pushing or towing the vehicle.

## 5. Driving guide

### WARNING

- Do not keep starting the engine for a long time in a poorly ventilated place or an enclosed place. The engine exhaust contains harmful gases which can make people comatose and even suffocate.
- Never let the engine idle unattended.
- Do not add a starting aid for starting the engine, as it is likely to make the engine run at high speed or cause an explosion.

### 5.1.3 Shut down the engine

- Park the vehicle steadily and apply the parking brake.
- Shift the gear to "P".
- Press START/STOP button to shut down the engine.

### NOTE

After the engine is shut down, the radiator fan may still run for a while.

### Emergency shutdown

When the vehicle is running, press and hold START/STOP button or quickly press the START/STOP button three times in a row, the START/STOP button will switch from the "ON" gear to the "ACC" gear, shut down the engine, and realize emergency shutdown.

The engine can only be restarted in a few seconds after emergency shutdown. Restart the engine as follows:

- Switch the gear to "P" or "N" and press the START/STOP button to start the vehicle.

### WARNING

**Emergency shutdown is forbidden during normal driving, as it is likely to lead to vehicle damage, safety and power steering failure, and traffic accidents.**

### Precautions for parking

When parking, switch the gear to "P" or "N" and pay attention to the following matters:

- Pay attention to the direction the vehicle is parked, for fear of damage to the green belt with the exhaust spraying on the plants.
- Try to park on a flat and straight road instead of a steep slope.
- When parking on a slope, regardless of whether the vehicle is facing the top or bottom of the slope, the front wheels should be turned towards the curb.
- Apply the parking brake, shut down the engine, and turn off all lamps and electrical consumers.
- When leaving the vehicle, be sure to carry valuables and vehicle key with you, and confirm that the sunroof, windows, doors and trunk lid are all closed.

### WARNING

- When leaving the vehicle, the engine must be turned off, the parking brake must be applied, and the vehicle key must be carried with you key.
- Do not leave any person in the vehicle. Otherwise, suffocation, coma and even death can easily occur in the closed space.
- Do not park near flammable and explosive materials.

### 5.1.4 Instruction for the gear

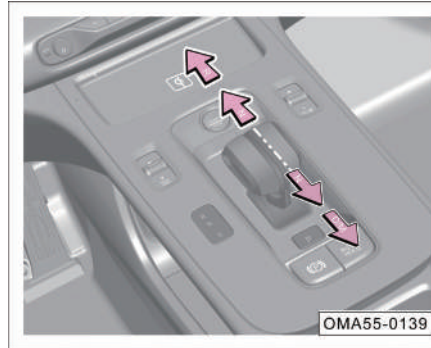

The gears of the gearshift lever are “ P, R, N, D, M\* “. When the power supply of whole vehicle is in “ON” gear, the corresponding gear information should be displayed on the instrument cluster after the gear is switched.

- Push the gearshift lever forward and enter the “R” gear from the “D” gear. There will be two resistance points, the first of which reached is at the “N” gear position and the second is at the “R” gear position.

- Push the gearshift lever backwards and enter the “D” gear from the “R” gear. There will be two resistance points, reach the first resistance point for “N” gear position and reach the second resistance point for “D” gear position.

### WARNING

**The “R” or “P” gear can be engaged only when the vehicle is completely stationary, otherwise the transmission will be damaged.**

## 5. Driving guide

### P: Parking gear

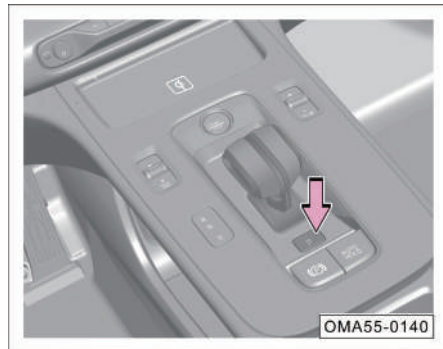

- After the vehicle is completely stopped, press this gear to realize parking.
- When parking for a long time, depress the brake pedal, switch the gearshift lever to the "N" position, pull up the "EPB" button, release the brake pedal, and then press the "P" button.

### i NOTE

- The instrument shows the current gear display information. Please check it carefully.
- Before the engine launches, the operating gearshift lever will not shift to the required forward gear "D" and reverse gear "R".
- When the shift system fails and the "P" gear can not be disengaged, please contact the GAC Motor authorized shop for repair.

### R: Reverse gear

- Switch this gear when reversing.
- When the vehicle is completely stationary and the gear is in "P" or "N" or "D" or "M" gear, press the brake pedal to push the gearshift lever forward to the second resistance point position, and the gear will be switched to "R" gear.



### N: Neutral gear

- Switch this gear during temporary parking.
- When the gear is in the “P” gear, step on the brake pedal and push the gearshift lever forward or backward to the first resistance position, and the gear will be switched to the “N” gear.
- When the gear is in “D” or “M” gear, step on the brake pedal and push the gearshift lever forward to the first resistance point position, and the gear will be switched to “N” gear.
- When the gear is in “R” gear, push the gearshift lever back to the first resistance point position, and the gear will be switched to “N” gear.

### WARNING

**When the vehicle is driving, do not switch to the “N” gear for sliding, otherwise it is very easy to cause an accident.**

### D: Forward gear

- Shift into this gear during normal driving.
- From “P” to “D”, you need to depress the brake pedal and push the gearshift lever back to the second resistance point.
- Enter the “D” gear from the “N” gear, step on the brake pedal, and push the gearshift lever backward to the second resistance point.
- Enter the “D” from the “M” gear and push the gearshift lever backward to the second resistance point.

### M: Manual drive position\*

- Switch this gear when entering manual drive position.
- Only when entering “M” gear from “D” gear, push the gearshift lever back to the position of the second resistance point, and the gear position will be switched to the “M” gear.
- After switching the “M” gear, manual upshift/downshift can be achieved by manually operating the paddle shifter on the steering wheel.

### Driving mode

Gearshift system have ECO (economy), COMFORT (comfort), SPORT (sports), SPORT+ (top speed) and DIY (custom) driving mode, which can be switched through driving mode knob.

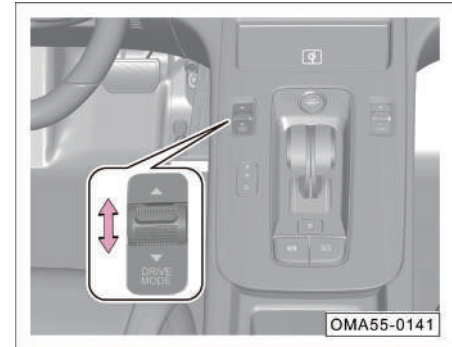

Place the vehicle power supply in the “ON” position. By toggling the driving mode knob up/down, you can click ECO → COMFORT → SPORT → SPORT + → DIY → ECO. The target driving mode is cyclically switched. See => see 181 page

## 5. Driving guide

### ECO mode

- The instrument displays ECO, indicating that the vehicle enters the ECO mode.
- The fuel economy of the vehicle is the best in this mode, when the dynamic response of the whole vehicle is gentle.

### COMFORT mode

- The instrument displays COMFORT, indicating that the vehicle enters the COMFORT mode.
- The vehicle comfort is better when it is in a mode that the dynamic response of the whole vehicle is moderate.

### SPORT mode

- The instrument displays SPORT, indicating that the vehicle enters the SPORT mode.
- The vehicle has good dynamic performance and a certain degree of comfort when it is in a mode that the vehicle has fast dynamic response.

### SPORT + mode

- The gauge displays SPORT +, indicating that the vehicle enters the TOP SPEED mode.
- The vehicle power response is aggressive, and the vehicle power is violent in this mode.

### “DIY” mode

- The instrument displays DIY, indicating that the vehicle enters the DIY vehicle driving mode adjustable function.
- Users can customize driving mode that conform to their driving habits and driving styles, and can cooperate with instruments to set the functions of vehicle-related systems.

#### **i** NOTE

- The driving mode can enter when the gear position of the whole vehicle is in the “P”, “R”, “N” and “D” gears.
- When the vehicle enters the corresponding driving mode, the corresponding indicator lamp of the instrument cluster will come on.
- The driving mode has the memory function. When the engine is turned off and restarted, the transmission will be still in the corresponding driving mode.

### Paddle shifter instructions \*

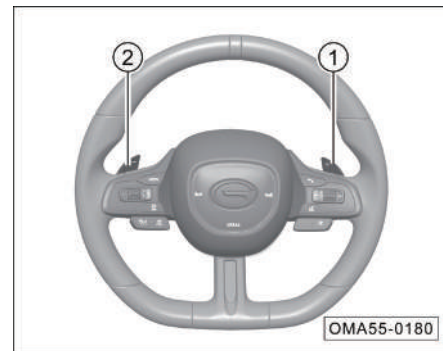

Paddle shifter allows both hands to complete an upshift or downshift without leaving the steering wheel.

- ① Upshift paddle
- ② Downshift paddle

Operating instructions for entering manual mode:

- Enter the long-term manual mode only when the whole vehicle gear is in “M” gear.
- Conduct manual upshift by pressing paddles ① “+”.
- Conduct manual downshift by pressing the paddle ② “-”.

- Enter manual mode for a short time only when the vehicle is in "D" gear.

Instructions for exiting manual mode:

- push back to the first resistance point or the second resistance point through the gear lever, or press and hold the paddle shifter to exit the long-term manual mode ① "+" 1.5s.
- Press and hold the paddle shifter ① "+" 1.5s to exit the temporary manual mode.

### 5.1.5 4 + X driving mode

#### Optional driving mode

E Energy saving	ECO	Super energy saving, economical driving characteristics
C Comfort	COMFORT	Comfortable and quiet, taking into account economical driving characteristics
S Sport	SPORT	Powerful and comfortable driving characteristics
S+ Extreme-Speed	SPORT+	Power rage, purely mechanical driving characteristics
DIY	DIY	Free combination, personal preference setting

The "4 + X mode" refers to four driving modes + user-defined driving modes, namely ECO (economical mode), COMFORT (comfortable mode), SPORT (sport mode), SPORT+ (extreme-speed mode) and DIY (User-defined mode) driving modes. After you select the corresponding driving mode, the driving mode information is displayed on the instrument cluster.

Depending on the driving mode selected, the following vehicle characteristics will change:

- Power drive system
- ESP
- Turning force applied to the steering wheel

- Exhaust sound wave\*
- Intelligent air conditioning control
- Instrument display atmosphere and theme
- Ambient light color and rhythm switch, etc.

#### Driving mode memory switch

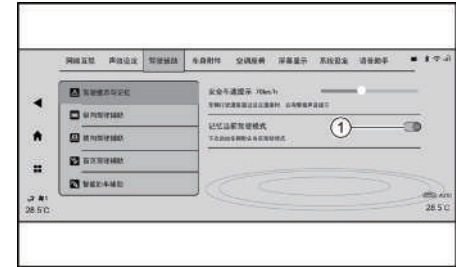

- If driving mode memory switch ① is off, the ECO in driving mode will be enabled when the engine is started.
- If driving mode memory switch ① is on, the previously selected driving mode will be enabled when the engine is started.

## 5. Driving guide

### Driving mode switching method

Central control entity dial switching

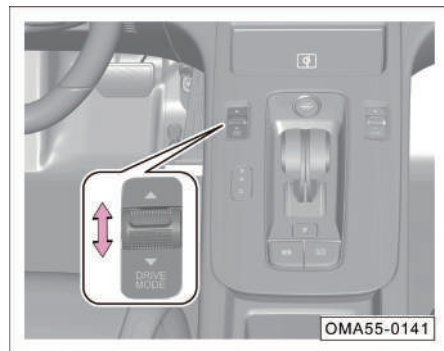

- By moving the toggle button up/down, the target driving mode can be selected in the “ECO → COMFORT → Sport → Sport + → DIY .....”, jump in gradual circulation, and select the target driving mode.

### i NOTE

When the driving mode knob is toggled, the driving mode switching interface will be displayed on the multi-function touch screen, and the parameter information of power, steering and ESP in the current mode will be displayed.

### Switch the central control mode interface

1. Go to the driving mode application interface through the driving mode card in the smart card area on the left side of the AVNT, and click soft button to select the driving mode.



2. Click the menu key  in the system navigation bar on the left side of the desktop to enter the system detailed application menu interface, click the driving mode icon to enter the driving mode application interface, and click the soft button to select driving mode.

### Driving mode parameter settings

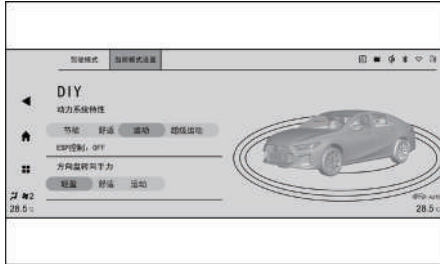

After entering the driving mode interface, click Current Mode Settings to enter the driving mode settings to set the system parameters under the current driving mode:

- Powertrain characteristics
- Turning effort of the steering wheel
- Exhaust sound wave\*
- HMI display mode
- A/C comfort curve
- Music rhythm mode
- Custom ambient light color

### CAUTION

- The system parameters that can be set in the driving mode setting page are adjusted according to the configuration of the vehicle (such as exhaust sound, ambient light, etc.).
- All system parameters cannot be set in SPORT+ mode.
- When SPORT+ mode and POWER mode are extreme speed, ESP is TOP SPEED mode, which will reduce ESP intervention on the vehicle to a certain extent. The driver needs to adjust the driving state of the vehicle in time to avoid risks such as vehicle sideslip.
- "HMI Display Mode" is selected not to follow at any time, and the instrument theme will not change driving-sensitive mode switching.
- Ambient light the driving-sensitive mode is set in "My Car", the ambient light driving-sensitive mode is switched. Otherwise, the effect ambient light be displayed according to the custom color.

### 5.1.6 SPORT + (Extreme) mode unlocked

After the SPORT + extreme driving mode is successfully unlocked, you can experience the SPORT+ driving mode with pure mechanical sense of the vehicle, and the following characteristics changes of the vehicle will occur:

- Extreme power mode
- Roaring exhaust sound
- Ejection control for greater torque
- Top speed ESP control mode
- Top speed theme of instrument cluster display
- Pop-up window of AVN screen quintuplet meters
- Steady steering hand force, etc.

## 5. Driving guide

SPORT+ mode on the vehicle can provide an excellent driving experience, but it is necessary to unlock this mode after the vehicle or user account has reached the preset conditions for the experience.



- Go to the AVNT and the setting interface of driving mode. Before unlocking, the "SPORT+" soft button is grayed out and cannot be used.
- Click the lock icon on the SPORT + icon to access the unlock progress view screen; You can view the unlocking progress of the current vehicle.

### SPORT + Unlock activation code

Activation code acquisition



- When the driving score and honor score meet the unlocking conditions, the <GAC Motor> APP will synchronously push the activation code of the vehicle bound to the account, and enter it into the activation code unlocking box of the center console display to permanently unlock the SPORT + mode of the vehicle.

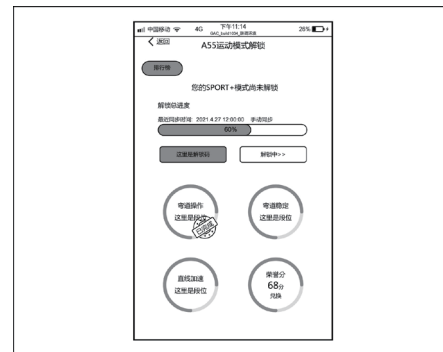

- The activation code is bound to the vehicle, with one code per vehicle; You can view it in the SPORT + section of the GAC Motor APP.
- After resetting SPORT + unlocking, you can interrupt the SPORT + unlocking resetting by inputting the activation code. However, the unlocking result is not included in the statistics of the speed battle list.

Introduction to sport + unlocking

### 1. SPORT + Unlockable Functions

After SPORT + is successfully unlocked, you can experience SPORT + driving mode, extreme power characteristics and ejection control, ESP control TOP SPEED mode, AVN dial pop-up window, etc.

### 2. SPORT+Unlock method

AV host unlocking method:

SPORT+unlocking can be realized through driving score, activation code, total mileage, etc.

- Driving score unlocking: When driving a vehicle safely over a corner and accelerating straight, the vehicle will calculate the score according to the driving conditions of curve handling, curve stability and straight acceleration, so as to obtain the driving score. When the specified driving score is accumulated, SPORT+unlocking can be realized.
- Activation Code Unlock: The <GAC Motor> APP can be used to scan the QR code on the vehicle for the driving score and the honor score exchanged from the APP, when the sum of two scores meets the unlocking conditions, the APP will push the activation code to the vehicle owner. The vehicle owner can input the activation code into the unlocking box

of the center console display to realize SPORT + unlocking of the vehicle and the owner.

- Total mileage unlock: When the vehicle does not meet the driving score unlocking and honor score unlocking, but the driving mileage reaches 3000 km, the vehicle will automatically unlock the SPORT + mode.

### CAUTION

- The user needs to bind the vehicle in the <GAC Motor> APP and update the driving score of the current vehicle synchronously by scanning the QR code each time.
- After the vehicle is unbound from the <GAC Motor> APP, the driving score of the account will be cleared, and the vehicle needs to be re-bound to scan the code to synchronize the driving score.

AVNT unlocking method:

You can use Trumpchi's account number, activation code, and total mileage to achieve SPORT + unlocking.

- Unlock Trumpchi Account: Log in to the Trumpchi account on the AVN, and the AVN will synchronize the driving score and honor score in the <GAC Motor> APP to the AVN. When the driving score and honor score sum meet the unlocking conditions, the SPORT + mode of the login vehicle will be unlocked.
- Activation Code Unlock: When the sum of driving points and honor points meets the unlocking requirements, the APP will synchronously push the activation code of the vehicle bound to the account, and the owner can input the code into the unlocking box on center console display, and the SPORT+ mode of the vehicle will be permanently unlocked.
- Total mileage unlock: When the account does not meet the driving score and honor score unlocking, but the vehicle owner has a mileage of 3000km, the SPORT + mode of the vehicle will be unlocked.

## 5. Driving guide

### CAUTION

- The user must ensure that the AVNT account remains logged in so that the driving score and driving mileage can be accumulated. All driving score and driving mileage during the exit of the account are not counted. 3000km unlock refers to the number of kilometers traveled by the account.
- Accounts that have been unlocked can log in to different vehicles to realize the unlocking of SPORT+.

### SPORT+ unlock reset

Lock SPORT+ button

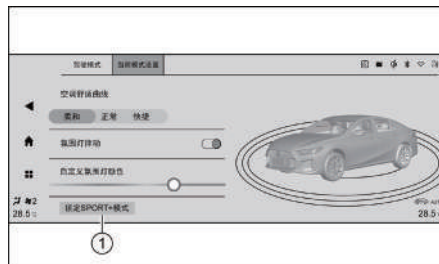

After SPORT + is successfully unlocked, click soft button ① Reset SPORT + Unlock. After you confirm the reset, the SPORT + mode will be locked again; The SPORT + mode can only be successfully unlocked again using the driving score (three scores of curve handling, curve stability and straight acceleration).

### Lock SPORT + Second Confirmation

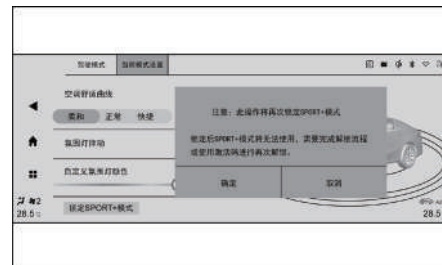

You can also enter an activation code midway to interrupt the SPORT + unlocking reset, but the unlocking score is not included in the ranking statistics.



### <GAC Motor> APP SPORT + Zone

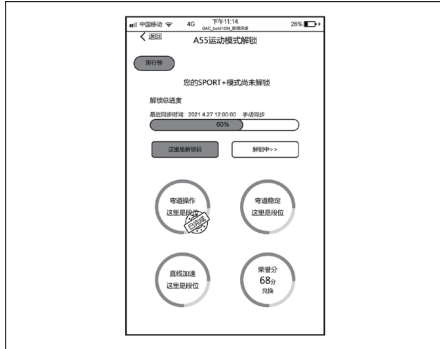

- After you bind the vehicle, you can log on to the SPORT + section in the <GAC Motor> APP <Service> to view the SPORT + unlocking progress and speed list online.
- When SPORT + is unlocked for the first time, the SPORT + Extreme Speed list displays the Extreme Speed Billboard. The driving score and honor score are included in the ranking of the Billboard. The ranking cannot be repeated.
- After SPORT + is reset and unlocked, the SPORT + speed list displays the speed battle list. Only the driving score will participate in the battle ranking, and the ranking can be repeated.

### Driving score

The SPORT+ mode can be unlocked when the driving score meets the conditions. The driving score consists of three sub-scores: corner maneuvering, corner stability and straight-line acceleration, and it is not necessary to achieve all three sub-scores to unlock the SPORT+ mode.

- Cornering maneuvering points: Driving the vehicle into and out of the corner at a safe speed, the vehicle will increase the cornering maneuvering points when it recognizes the driver's movement in favor of the longitudinal and lateral attachment balance.
- Cornering stability score: When driving the vehicle over a corner at a safe speed and the vehicle recognizes that the driver's operation is conducive to improving the cornering stability, the cornering stability score will be increased.
- Straight acceleration score: When driving the vehicle at a safe speed, the vehicle will increase the straight acceleration score when it recognizes that the driver is accelerating under safe conditions.

### Honor score

Honor points are obtained through the posting, follow posting, mall modification, test drive activities, model promotion and other channels on the <GAC Motor> APP.

### 5.1.7 Launch control

The vehicle starts on a proper high-adhesion road, and the launch control can make the vehicle get the best acceleration when starting at a stationary state.

#### Operation method

1. Select sport or sport+ driving mode by the central control entity knob under driving mode or AVNT driving mode application interface.
2. Press the brake pedal deeply with the left foot, put it in the D gear, and fully press the accelerator with the right foot. When the instrument shows "Ejection mode is activated", quickly release the brake pedal within 3s.
3. After each ejection operation, a short cooling down is required before carrying out the next ejection start-up.

## 5. Driving guide

### **i** NOTE

- After the ejection mode is activated, if the brake pedal is not released for more than 3s, and the ejection function will exit, and an alarm prompt of “clutch overheating” or “ejection skill cooling” may appear.
- It is not recommended to repeat the preparation for ejection start in place (the vehicle will not work after stepping on the accelerator pedal and brake pedal), and the alarm prompt of “Clutch Overheating” or “Ejection Skill Cooling” may occur.
- When the instrument prompts “Clutch Overheating” or “Ejection Skill Cooling”, please stop in a safe position to cool down.
- After the EPB electronic handbrake is pulled up, the driver must wear a seat belt to start (including ejection start), otherwise the EPB will not automatically unlock and the transmission will be easily damaged.

### **⚠** WARNING

- **The ejection start is limited to professional tracks such as the proving ground. It is not recommended to use it on public roads. Please be sure to use this function when permitted by relevant laws and regulations and the surrounding traffic conditions are safe.**
- **Please avoid using this function on wet and slippery roads, otherwise the vehicle will lose control and cause accidents.**

### **👁** CAUTION

Compared with normal starting, ejection starting will increase the load of transmission system related parts and aggravate wear and deterioration. In order to avoid affecting the service life of the vehicle, please do not use it frequently.

### 5.1.8 Exhaust sound wave\*

The user can switch the exhaust mode through the interactive interface, and control the opening of the tuning valve according to the engine speed, throttle opening and gear signals to realize continuous adjustment of exhaust system acoustics and back pressure. When the exhaust sound valve is opened, the dynamic and pleasant exhaust sound can be heard.

#### On and Off

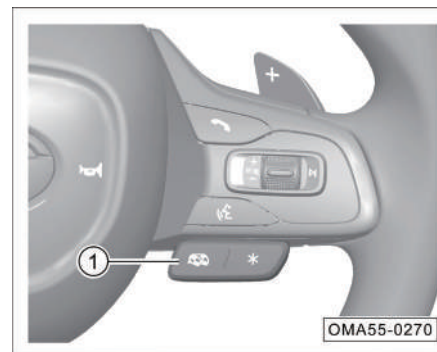

Turn on or off the exhaust sound according to different driving modes with the exhaust sound button switch ① on the right side of the steering wheel.

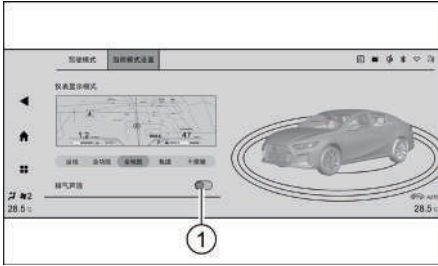

Enter the driving mode-current mode setting through the AVNT interface icon, and select soft button ① to turn on or turn off the exhaust sound according to different driving modes.

### Operation method:

- In ECO driving mode of the whole vehicle, the exhaust sound is turned off and cannot be turned on by the switch.
- In SPORT + driving mode of the whole vehicle, the exhaust sound is turned on and cannot be turned off by the switch.
- When the driving modes of the whole vehicle are COMFORT, SPORT, or DIY, the exhaust sound is first executed according to the on/off state in the driving mode. The user can change the exhaust sound state by pressing the steering wheel exhaust sound switch and save the new state to the current driving mode.

- When the exhaust sound is on, the instrument will display the exhaust sound icon ; Turn off the exhaust noise and the icon disappears.

### CAUTION

- Turn off the exhaust noise when driving on sections that need to be quiet (such as schools, hospitals, etc.).
- When the vehicle is cold start at a low temperature in winter, the rear exhaust pipe may make a “clang” noise, and the noise disappears after the vehicle is hot. This noise is caused by the action of the rear exhaust pipe sound wave valve to eliminate icing obstruction. When the valve breaks ice or the hot car ice melts, the noise will be eliminated, which is a normal phenomenon. Please feel free to use it. If the exhaust sound function cannot be used normally, go to the GAC Motor authorized shop for maintenance as soon as possible.

## 5.2 Brake system

### 5.2.1 Service brake

Under certain driving and weather conditions, squeaks, screams, or other noises may be heard from brakes when the brake pedal is depressed for the first time or lightly stepped on, or braking noise during light or moderate braking, especially for new vehicles (as their brakes have not undergone running-in), which is normal, and does not constitute a failure symptom of braking system nor has effects on the braking safety and performance.

### CAUTION

- If there is metal friction rasp, the brake lining may be worn to the limit. Please go to the GAC Motor authorized shop for inspection as soon as possible
- If the steering wheel vibrates or twitches continuously during braking, go to the GAC Motor authorized shop for inspection as soon as possible.

## 5. Driving guide

---

### NOTE

- Do not rest your foot on the brake pedal during driving, otherwise the brakes will heat up to an abnormally high temperature, and the brake linings and brake pads will wear excessively, increasing the braking distance.
- When driving down a long slope or a steep slope, downshift to a low gear (in manual mode) to avoid continuous application of the brake, so as to make full use of engine braking and reduce brake load.
- Continuous application of the brake will cause brake overheat and result in a temporary loss of braking performance.

### NOTE

- Under normal driving conditions, brake linings will wear, and dust will accumulate on wheels, which is inevitable but yet has no effect on the braking performance.
- If rust and corrosion exist because the brake linings and brake discs are not used or used rarely, noise may be heard from brakes for the first use. This is normal. It is recommended to choose a safe area and good road conditions and brake the vehicle several times to clean the brake linings and brake discs.

### Brake booster

The brake booster is used to increase the pressure applied by the driver on the brake pedal, and it only works when the engine is running.

If the brake booster does not work properly due to a fault, or when the vehicle is towed, the force on the brake pedal must be increased to compensate for the assist power loss of the brake booster.



### WARNING

- **Never make the vehicle coast with the engine shut down, because at this moment, the brake booster does not work, the braking distance will be greatly increased, and an accident is likely to be caused.**
- **If the brake booster is not working (for example, when the vehicle is being towed), the brake pedal must be depressed with a much greater force than normal.**

### Braking effect and braking distance

The braking effect and braking distance mainly depend on the driving environment, road conditions and driving style,

With worn brake linings, the vehicle cannot be braked effectively. The wear rate of brake linings mainly depends on the vehicle operation conditions and driving style. If the car is often driven in urban areas, short-distance driving or used as a racing car, it is recommended to increase the frequency of checking the thickness of the brake lining during the maintenance period specified in the Warranty Manual.

After wading, heavy rain or vehicle washing, brake linings may get wet or icy (in winter), resulting in a reduction in braking effects. In this case, the brake pedal must be lightly depressed to heat the brake by friction and evaporate the moisture to restore braking effects.

#### WARNING

**A new tire and brake lining having not undergone running-in do not have the best adhesion and friction characteristics.**

- **New tires do not yet have the best adhesion, so please drive carefully for the first 500km to avoid accidents!**
- **New brake linings in the first 200km to 300km driving distance do not get the best friction characteristics, and braking effects are not as good as expected, so new brake linings must be subject to running-in. Braking effects can be compensated by increasing the force applied to the brake pedal. New brake linings must also be subject to running-in.**
- **Never get too close to other vehicles or be in a situation prone to emergency braking while driving. Be especially cautious when driving with new tires and brake lining that are not running-in, and prevent the above accidents!**

#### WARNING

**When the brake is wet or icy or when the vehicle is running on a salted road, the braking lag may occur, resulting in a longer braking distance. Therefore, be careful to prevent accidents.**

- **A longer braking distance or a fault in the braking system will increase the accident rate.**
- **Lightly depress the brake pedal to check the brake.**
- **Lightly depress the brake pedal to dry brakes or remove ice or anti-skid salt from brakes.**

## 5. Driving guide

---

### WARNING

When brakes are overheated, braking effects will reduce, increasing the braking distance!

- Take care to avoid overheating brakes.
- When the car runs downhill, the brake load increases, and the brake is prone to overheating.
- It is recommended to shift into the low gear (manual mode) before the car goes down for a long distance along a steep slope, reduce the vehicle speed and make full use of the braking effect of the engine to reduce the brake load.
- Do not continuously press the brake pedal to overheat the brakes and extend the stopping distance. Brake the vehicle intermittently according to road and traffic conditions.

### WARNING

- The brake fluid must be changed every two years. If the brake fluid stays in the brake system for a long period, air resistance may occur in the pipeline during braking, reducing the braking effect significantly and impairing driving safety, and even causing failure of the brake system, resulting in an accident thereby!
- If the front spoiler is out of standard or damaged, it will block the cooling airflow to brakes, causing brakes to overheat and degrading the braking effect.

### 5.2.2 EPB system (EPB)

The driver can apply or release the parking brake by operating the EPB button. HSA can be applied for driving on a slope. When the accelerator pedal is depressed with the vehicle parked, the EPB will be automatically released to provide driving assistance for the driver.

### CAUTION

The EPB will apply a fixed force according to the gradient for braking.

- If the vehicle slides downwards after parking, the EPB will automatically increase the brake force.
- If the vehicle continues to slide after the braking force is automatically increased, please depress the brake pedal and drive the vehicle to a flat road. Contact the GAC Motor authorized shop for inspection in time.

### Application of static park brake

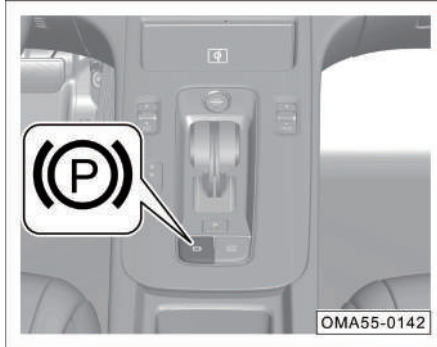

- When the vehicle is stationary, the EPB button is lifted, and the key indicator lamp and the (P) indicator lamp in the instrument cluster are lit to indicate EPB has been applied.
- When the gear is switched from non "P" gear to "P" gear, the EPB will be applied automatically.

### i NOTE

- The EPB can also be applied when the vehicle power switch is set to "OFF" position.
- After the vehicle is parked steadily, the EPB should be applied first.
- When the EPB is working, operating noise can be heard, which is normal.
- If the vehicle is coupled with a trailer or is to be parked on a steep slope, it is recommended to pull up the EPB button again after the first application of EPB to ensure the maximum braking effect.
- On a slope with a gradient of 17% to 30%, in 5 minutes after the EPB is applied for the first time, it will be applied again. At this time, operating noise can be heard, which is normal.

### ⚠ WARNING

- **Be sure to apply the EPB during parking.**
- **When the vehicle is running, do not apply the EPB for speed reduction unless necessary, as the EPB only applies braking force to rear wheels, which is likely to cause traffic accidents.**

## 5. Driving guide

### Release static park brake

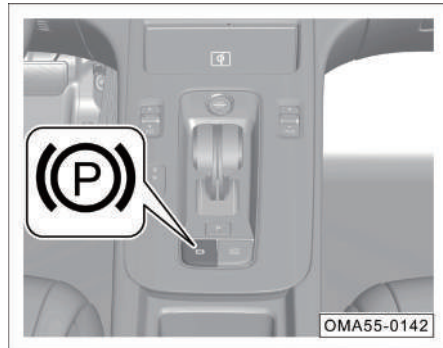

- When the vehicle power switch is set to "ON" position, depress the brake pedal.
- Press the EPB button. The button indicator lamp and the indicator lamp (P) on the instrument cluster will go out, indicating that the EPB has been released.

### i NOTE

- If the EPB button is pressed without depressing the brake pedal, the EPB will not be released, and the instrument cluster will give a visible warning tell-tale together with an audible beep alarm.
- When the EPB is being released, operation noise will occur, which is normal.
- When the battery power of the vehicle is insufficient, the system cannot deactivate the EPB. If conditions permit, jumper cable emergency start => See page 335 before deactivating the parking brake. Please contact GAC Motor authorized shop for handling.
- If the EPB has not been used for a long time, the system will perform automatic test, and operation noise will be heard at this time.

### Application of dynamic emergency brake



- If the service brake fails while the vehicle is in motion, try to continuously pull up the EPB button to achieve emergency braking. Release the EPB button or depress the accelerator pedal and the system exits the emergency braking.



### CAUTION

If the following phenomena occur, please operate the EPB again, and if the fault is still not eliminated, please contact GAC Motor authorized shop for maintenance.

- If the (P) indicator lamp flashes red continuously, it means the EPB is partially engaged/disengaged except for the status or the presence of a system fault.
- If the indicator lamp (P) comes on in red when EPB is not applied, it indicates that the system is abnormal.
- If the indicator lamp (P) comes on in yellow, it indicates that a fault is detected in EPB and the EPB is degraded.

### CAUTION

- Do not use dynamic emergency braking unless necessary, as it is likely to cause traffic accidents. Moreover, the braking distance is longer than braking by depressing the brake pedal, and the service life of the parking brake system will be shortened.
- If you pull up the EPB button when the vehicle is running, the instrument cluster display will give a visible warning tell-tale together with an audible beep alarm.
- If you release the EPB or depress the accelerator pedal during dynamic emergency braking, the EPB will be released. If the EPB button is pulled up until the vehicle stops, the EPB will remain engaged.

## AUTO HOLD

### On and Off

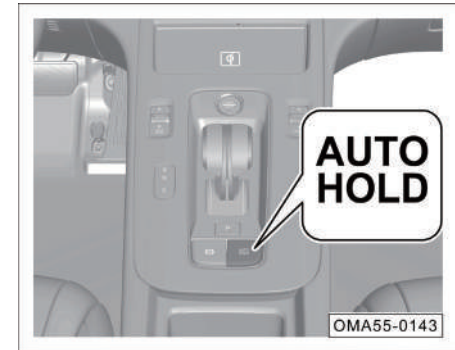

- When the engine is started and the driver's seat belt is fastened, press the AUTO HOLD button, the button indicator lamp illuminates and the AUTO HOLD is turned on. Press this button again. The button indicator lamp goes out, and the AUTO HOLD is disabled.

## 5. Driving guide

### Activation

When this function is enabled, it supports automatic brake application and release under stop & go conditions. When the driver brakes the vehicle, the vehicle will be automatically parked to avoid slide at startup.

### Exit

Under the following conditions, AUTO HOLD will be disabled and the parking brake will not be locked:

1. The accelerator pedal is depressed at startup.
2. The engine stops while the vehicle is running.
3. The EPB is manually released.
4. The AUTO HOLD button is pressed when the brake pedal is depressed.

For the sake of safety, the AUTO HOLD will be disabled and the parking brake will be locked under the following conditions:

1. Turn off the engine.
2. The driver's door is opened or the seat belt is unfastened when the vehicle is stopped.
3. The AUTO HOLD button is pressed to disable AUTO HOLD.

 CAUTION
When driving into a mechanism such as a vehicle washing device that transports the vehicle with a conveyor belt, be sure to disable the AUTO HOLD, otherwise the vehicle cannot move or may run off the path.



## 5.3 Electronic service brake system

### 5.3.1 ESP (ESP)



ESP can effectively reduce the risk of sideslip.

#### On and Off









ESP is on by default when the vehicle is running. Press the  key to turn off ESP. At this time, the  indicator lamp on the instrument cluster will light up and the alarm message will be displayed.

### **i** NOTE

- When the vehicle speed is greater than 80 km/h, the ESP will be activated automatically.
- When the vehicle speed is less than 80km/h, the ESP, if inactive, can be activated by pressing the button .
- Press the  key. If the pressing time exceeds 10s, the system will consider it as a wrong operation and will not affect the working state of the system.

### ESP indicator lamp

- After the vehicle power supply is switched to the "ON" position, the  and  indicator lamp are on for several seconds, and the system goes out after completing the self-test.
- If ESP works during driving, the indicator lamp  will flash.
- After ESP is turned off, the indicator lamp  will come on.
- When ESP is faulty, the indicator lamp  will come on.

After the vehicle is started, if the  indicator lamp is on, it indicates that ESP has been turned off, and the instrument cluster display displays alarm information. You can try to turn off the vehicle power supply, then turn on the power supply of the whole vehicle and turn on the system again. When the indicator lamp  goes out, it indicates that the system has started working.

If the battery connector is disconnected from the cable and then connected, the  indicator lamp may light up when the vehicle power supply is enabled, and the indicator lamp will go out after a short distance driving.

For driving safety, ESP should be turned on. The ESP can be disabled in the following special cases:

- When the vehicle runs with tire chains.
- When the vehicle runs on roads covered with deep snow or on soft grounds.
- When the vehicle is trapped on muddy roads, etc., and you need to move it back and forth.

### Traction control system (TCS)

TCS is a subsystem of ESP. TCS determines whether the driving wheel is slipping according to the driving wheel speed and the drive wheel speed. When the former is greater than the latter, TCS will inhibit the driving wheel speed, thus controlling the vehicle to prevent skid.

When ESP is turned off or on, TCS will be turned off or on accordingly.

## 5. Driving guide

---

### 5.3.2 ESP (ESP) TOP SPEED mode

When the power mode selection is TOP SPEED mode, the ESP will also automatically switch to the TOP SPEED mode. Compared with SPORT mode, there is less ESP and TCS intervention under TOP SPEED mode, the driver can operate the vehicle more freely, and the risk of skidding and accidents will increase accordingly.

Under TOP SPEED mode, the driver needs to be experienced and have sufficient driving skills to control the vehicle. If you select TOP SPEED mode:

- Vehicle steering is less than the driver's expectation: The vehicle tends to go straight rather than turn.
- The vehicle turns more than the driver expects: The vehicle tends to flick.
- ESP can only play a limited role in improving driving stability.
- The TCS is still enabled.
- The engine torque will no longer be restricted at full throttle.

- When you step on the brake pedal ESP, the system will automatically switch from the TOP SPEED mode to the dynamic mode to restore stability control.

#### CAUTION

Under TOP SPEED mode, please drive the vehicle carefully. It is recommended to use TOP SPEED mode only when driving on specially specified roads (such as closed racing circuits).

### 5.3.3 Anti-lock brake system (ABS)

Anti-lock brake system (ABS) is a subsystem of ESP. When the driver brakes, ABS automatically monitors the slip rate of the front and rear wheels. Before the wheels are locked, adjust the wheel cylinder hydraulic pressure through the stages of pressure maintaining, decompression, and pressurization to keep the wheel slip rate within the specified range and prevent the wheels from locking.







When the brake pedal is stepped on in an emergency, and when the ABS enters the working state, the driver will feel the brake pedal vibrate, accompanied by a "click" sound when the brake master cylinder is running. When the brake pedal is stepped on under the following conditions, the ABS works and may feel vibration, which is a normal phenomenon:

- Gear shifting.
- Emergency braking.
- Sharp turns at high speed.
- Driving on a wet and slippery road.
- Passing over bumps or ditches.
- Driving off immediately after the engine is started.

### Anti-lock braking system (ABS) indicator lamp

After the vehicle power supply is switched to the "ON" gear, the instrument cluster  indicator lamp lights up for several seconds, and the indicator lamp goes out after the system completes the self-test.

If the following conditions occur, it indicates that the system is faulty:

- After the vehicle power supply is switched to the "ON" gear, the  indicator lamp does not light up.
- After the vehicle power supply is switched to the "ON" gear, the  indicator lamp lights up for several seconds and does not go out.
- The indicator lamp  comes on when the vehicle is running.
- When there is a fault in the ABS, the indicator lamps ,  and  come on.

### Electronic brake force distribution (EBD)

As a part of ABS, the electronic brake force distribution (EBD) balances the distribution of braking force on the front and rear wheels according to the vehicle load during normal braking.

### Hydraulic brake assist (HBA)

HBA takes advantage of the rapid pressure generated in the brake system to help you get a short stopping distance in an emergency, it makes full use of the characteristics of ABS. After the brake pedal is released, HBA will be deactivated automatically, and the brake system will be restored to its normal working state.

#### WARNING

**HBA is only an assist system for improving the driving safety, but it is subject to the limitation of the laws of kinematics. Therefore, please adjust the driving speed according to the road conditions and traffic regulations.**

### 5.3.4 HHC (HHC)

HHC allows the driver to move the foot from the brake pedal to the accelerator pedal when driving off on a slope without application of the parking brake, so as to prevent accidents resulted from sliding.

#### Activation conditions of HHC

- When the slope degree is greater than 4%, the gearshift lever is not in the "P" or "N" gear, and no EPB is applied. The driver depresses the brake pedal to stop the vehicle and puts it at a stationary state. At this time, if the driver releases the brake pedal, the HHC starts to apply braking pressure to the vehicle, and the pressure is maintained for 1 s.
- During HHC operation, when the engine torque exceeds the drag torque of the vehicle, the brake pressure will be released and the start will be completed smoothly.
- When going downhill and switching to "R" gear, the HHC will also work.

## 5. Driving guide

### **i** NOTE

- When you drive off on a steep slope or drive downhill with transmission in "R" position, HHC will automatically apply brake to prevent vehicle from sliding.
- HHC is integrated on the ESP system. If the HHC is faulty, the ESP indicator lamp illuminates and displays a graphic prompt through the instrument cluster display.

## 5.4 Driver assistance system

### 5.4.1 Cruise control system \*

The cruise control allows the car to run without depressing the accelerator pedal at the set car speed of 40~120 km/h.

### **⚠** WARNING

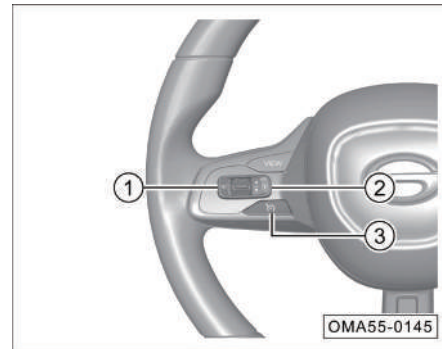

- **The cruise control shall be used with caution. After setting the vehicle speed, ensure that the vehicle maintains a safety distance from the lead vehicle.**
- **The cruise control shall be used with caution. After setting the vehicle speed, ensure that the vehicle maintains a safe distance from the lead vehicle.**
- **After exiting the cruise control mode, deactivate the cruise control in time.**
- **The cruise control is only used to assist driving and cannot replace automatic driving. Drivers must be alert to driving and control the vehicle.**

### Control buttons



- ① SET /-: Set cruise/deceleration
- ② RES /+: Resume cruise/acceleration
- ③ : Cruise main switch, turn on/off cruise function

### Activating cruise control



- Press the cruise main switch  key to turn on the cruise control system, and the white indicator lamp  in the instrument cluster will light up.
- Increase the vehicle speed above 40 km/h.
- If the SET/- button is pressed, the indicator lamp  on the instrument cluster will turn green, and the vehicle will enter the cruise control status. After that, release the accelerator pedal.

### Deactivating cruise control

The cruise control can be deactivated as follows:

- Step on the brake pedal (exit the cruise control and retain the cruising speed value before memory exit).
- Press the cruise main switch  key (exit the cruise control and delete the cruising speed).
- The gear is switched to "N" gear.
- When the engine speed is out of range (>6500 rpm, or<800 rpm), or when the vehicle speed is out of range (when the vehicle speed is>120 Km/h, or<35 km/h).
- ESP, engine or airbag failure.

### Resuming cruise control

When the cruise control is deactivated by depressing the brake pedal or pressing the button , the indicator lamp  on the instrument cluster will become white, and the cruise control can be reset by pressing the RES/+ button:

- When the vehicle speed is higher than 40 km/h, if the RES/+ button is pressed, the indicator lamp  on the instrument cluster will turn green from white, and the vehicle speed will return to the value set during the last cruise control.

### Increasing cruising speed

- Press the RES/+ key to increase the vehicle speed by 2 km/h for each press.
- Press and hold the RES/+ button to increase the vehicle speed continuously until the button is released.

<b>i NOTE</b>
<ul style="list-style-type: none"><li>• The maximum setable cruising speed is 120 km/h. When the vehicle speed is higher than 120 km/h, it cannot be adjusted by the RES/+ button.</li><li>• When the accelerator pedal is depressed for acceleration, the vehicle will temporarily deactivate the cruise control and run at the increased speed; after the accelerator pedal is released, the vehicle will resume the cruise control.</li></ul>

### Decreasing cruising speed

- Press the SET/-key to reduce the vehicle speed by 2 km/h for each press.
- Press and hold the SET/- button to decrease the vehicle speed continuously until the button is released.

<b>i NOTE</b>
When the vehicle speed is lower than 40 km/h, it can no longer be adjusted by the SET/- button.

## 5. Driving guide

### 5.4.2 ACC \*

The ACC is referred to as ACC for short, which can automatically adjust the following distance with the front vehicle during cruise control, and cruising speed can be 0~130 km/h.

ACC detects the relative distance and speed between the preceding vehicle and the vehicle in the same path according to the MMW radar installed on the front of the vehicle and IFC on the windscreen:

- When there is a vehicle ahead and if the vehicle ahead stops, ACC will control the vehicle to follow the vehicle ahead to stop automatically; If the vehicle in front starts, ACC will control the vehicle to start again under certain conditions. After following and stopping for a specific time Simply operate the  button or accelerator pedal to realize the following starting driving.
- When the speed of vehicle ahead is lower than the target speed set by the driver, ACC controls your vehicle at a safe distance from the vehicle ahead.
- When no vehicle is in front, ACC controls your vehicle to travel at the target speed set before.

#### NOTE





Precautions for use of radars and cameras.  
=> See page 242

#### WARNING

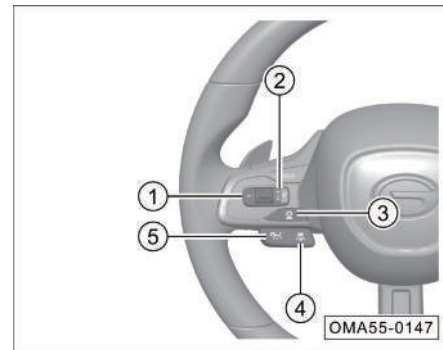
- **ACC is not a safety system, obstacle detector, collision warning or anti-collision system, but a comfort system. The driver must always maintain control of the vehicle and take full responsibility for the vehicle.**
- **The ACC system must be used cautiously according to the visibility, weather conditions, road and traffic conditions at the time. The driver must always keep control of the car and the distance from other vehicles.**
- **ACC cannot substitute for driver's attention and judgment. The driver is always responsible for ensuring that the vehicle runs safely at an appropriate speed and maintains an appropriate distance from other vehicles.**

#### Control buttons







- ①  : Deceleration key
- ②  : Restore/Synchronize/Accelerate key
- ③  : Adjust the vehicle distance and time interval
- ④  : Start and close ICA/switch to ICA
- ⑤  : Start and close ACC/switch to ACC

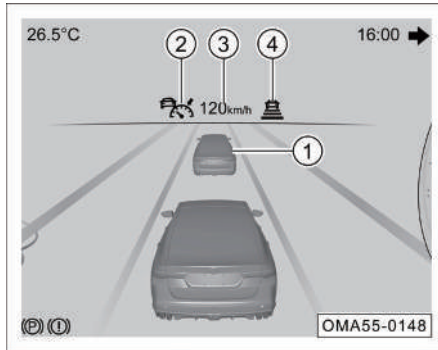

### Interface description



- ① Indicates the detected vehicle ahead.
- ② ACC indicator lamp:
  - The green ACC indicator lamp  illuminates to indicate that the ACC is active with target vehicle ahead. The white ACC indicator lamp  is on, indicating that ACC is not activated and there is target vehicle ahead.
  - The green ACC indicator lamp  is on, indicating that ACC is active and there is no target vehicle ahead. White ACC indicator lamp  lit Indicates that the ACC is working and there is no target vehicle ahead.

-  A yellow light indicates a fault in the ACC and should be serviced by the GAC Motor authorized shop in time.
- ③ Indicates the cruising speed of storage.
- ④ indicates the set cruising distance from the vehicle ahead.

When the ACC braking capacity is insufficient to maintain a proper distance between this vehicle and the vehicle in front, the system will send out the “driver takeover request”, and the instrument cluster will display the alarm information and sound at the same time. At this time, the driver shall step on the brake pedal according to the system requirements to reduce the speed.

### Activating ACC

- Press the  button, the corresponding green indicator lamp in the instrument will light up, and the vehicle will enter the ACC control state.

### NOTE

- The minimum cruising speed that can be set is 30 km/h.
- When the gear is not forward gear, it cannot enter ACC control.

## 5. Driving guide

---

### Canceling ACC

ACC can be canceled by:

- Opening the driver's door.
- Unfastening the driver's seat belt.
- Depress the brake pedal.
- Setting the gearshift lever to a position other than D.
- Press the  key (the corresponding indicator lamp of the instrument cluster is turned off, exit ACC, and clear the set speed).
- Pressing the EPB button.
- Deactivating the ESP.

Press  to exit the ACC in the following way:

- When the brake pedal is depressed (the brake pedal needs to be loosened).
- The gear is in a non-forward gear position (forward gear is required).
- Shift to non-forward gear (shift to forward gear).
- pressing the EPB button (it is required to release EPB).
- switching off the ESP (it is required to switch on the ESP for resuming the ACC).

### Resuming ACC

The corresponding indicator lamp of instrument cluster is white, the ACC function can be reset:

- Press the  key, the corresponding indicator lamp of the instrument cluster will light up in green and the vehicle speed will return to memory value of the last cruise set speed and enter the cruise control state.
- If no cruising speed has been stored, ACC will set the current vehicle speed as the cruising speed (if the current vehicle speed is less than 30 km/h, the cruising speed will be set at 30 km/h).

### Increasing cruising speed

To increase the vehicle speed, please operate as follows:

- Depress the accelerator pedal, increase to the speed of target vehicle and press the **+** key to cruise at a higher set speed.
- Press the **+** key, and the vehicle speed will increase by 5 km/h each time it is pressed.
- Press and hold the **+** key, the cruising speed will continue to increase at 5 km/h until the key is released.

#### **i** NOTE

- The maximum cruising speed that can be set is 130km/h.
- When the accelerator pedal is pressed to accelerate, the vehicle will temporarily exit ACC and accelerate with the driver's intention. After releasing the accelerator pedal, the vehicle will return to ACC and set cruising speed.

### Decreasing cruising speed

To reduce the vehicle speed, please operate as follows:

- Press **-** key, the vehicle speed is decreased by 5 km/h after each press.
- Press and hold **-** key, the cruising speed is continuously decreased by 5 km/h until the key is released or the cruising speed is equal to 30 km/h.
- During the cruise, lightly step on the brake pedal (ACC exit), keep braking to the target speed, and press the **+** key to cruise at the current speed.
- During the cruise, press the steering wheel **ESC** key (ACC exit), coast or lightly step on the brake to the target speed, and press the **ESC** key to cruise at the current speed.





### Controlling ACC distance

By pressing the **SET** key, you can switch the gear with the distance from the vehicle in front, and press to switch the first gear once to "Fourth gear → Third gear → Second gear → First gear → Fourth gear....." Sequential cyclically switching of At the same time, the instrument cluster will display the same number of cross bars as the ordinal number of the range.

## 5. Driving guide

### Activating ACC after following stop

When following a vehicle ahead, your vehicle will also be stopped if the vehicle ahead is stopped. During a certain period after such stop, ACC will keep your vehicle stationary by active pressurization of ESP; after this period, ACC will keep your vehicle stationary by activating EPB. When the front vehicle is driving away, the ACC of the vehicle is activated in three situations:

1. If the ACC indicator lamp  is green, ACC can actively resume and re-drive the vehicle after the front vehicle has driven away.
2. If the white ACC indicator lamp  is on, the instrument displays "Cruise Waiting" and the EPB is not activated, the driver can restore the ACC and re-drive the vehicle by pressing the accelerator pedal or pressing the  key.
3. If the white ACC indicator lamp  is on and EPB is activated, the driver can recover ACC and re-drive the vehicle by stepping on the accelerator pedal or pressing the  button first.

### System limitations

ACC is limited by physical laws and has certain system limitations. In some driving environments, the driver may feel that the ACC response is lagging or fails to control the vehicle as scheduled. Therefore, the driver must be ready to control the vehicle by himself at any time.

The following conditions will affect functions of the radar, so the driver must be particularly alert under these conditions:

1. Decelerating to stop. If the vehicle in front stops with emergency braking, ACC will also slow down or prompt the takeover request. The driver shall actively intervene in braking according to the takeover request alarm to completely stop the vehicle.

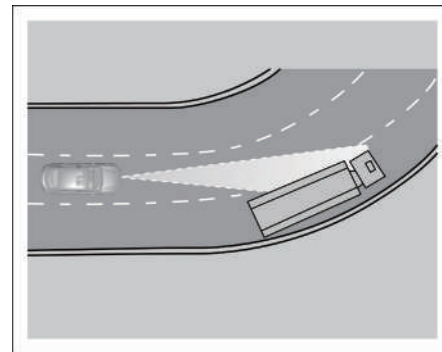

2. Driving through a curve. When driving through a curve, the radar sensor may not catch the vehicle ahead or may not be able to react to the vehicle in the adjacent lane. In this case, ACC may apply the brake to the vehicle in front, reduce the speed, or have no response to the vehicle in front. Depress the brake pedal or manually cancel ACC to exit the ACC system.

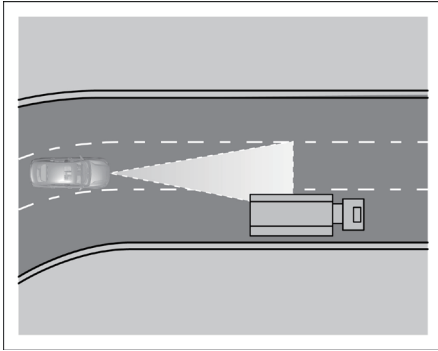

3. Drive out of the curve. During driving out of a long curve, as ACC will calculate the lane in advance, the radar may respond to the vehicles in adjacent lanes and apply the brake of your vehicle. This braking process can be interrupted by depressing the accelerator pedal.

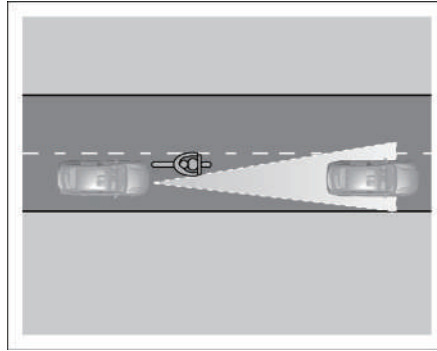

4. Narrow vehicles and Z-shaped traffic in front. The sensor can be identified only when the vehicle in front is narrow or the vehicle in front that is traveling left or right enters the radar sensor detection range, and the system cannot identify the vehicle outside the sensor detection range. ACC may be unable to identify narrow vehicles such as motorcycles, and has a risk of failing to accurately identify the distance from modified vehicles and vehicles involving non-standard transportation in front, so it is not recommended to take such vehicles as the target vehicle ahead.

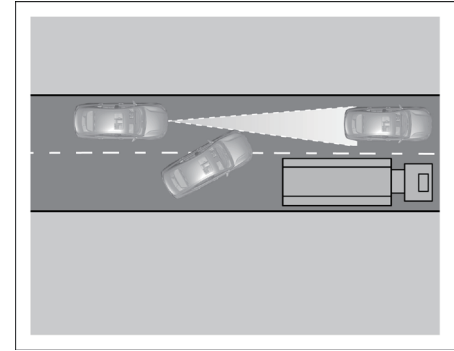

5. When another vehicle changes the lane. When a vehicle in an adjacent lane merges into your lane, if the vehicle does not enter the detection range in front of the vehicle, the radar sensor may not detect the vehicle, resulting in delayed ACC response.

## 5. Driving guide

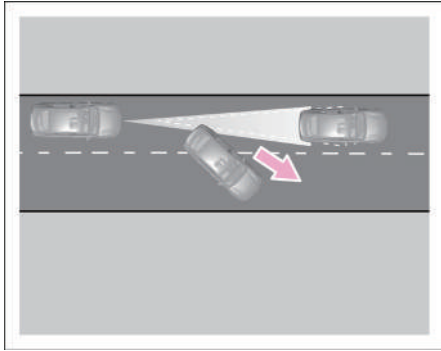

6. If the target vehicle in front is driven out suddenly and a stationary vehicle appears at close range, the radar sensor and brake actuator will incur a response lag, causing delayed braking response.
7. Factors that may deteriorate sensor function.
  - Heavy rain, water mist, ice and snow or sludge may deteriorate the radar sensor function, causing the ACC to be temporarily shut down. At the same time, the instrument cluster display displays the following text information: "The working conditions of the cruise control system are not satisfied" or "FCM is turned off". At this time, the ACC and FCM cannot function.

- In low temperature and alpine region, the front windshield is frosted and fogged due to temperature difference or frost, which causes the camera sensor to be blocked. The instrument cluster display will prompt the following text information: "The working conditions of the cruise control system are not satisfied" or "FCM is turned off". At this time, the ACC and FCM cannot function.
8. Brake overheating. If the brake is overheated due to emergency braking or when the vehicle is running down a steep slope, the ACC will automatically turn off temporarily and the following text message will be displayed on the instrument cluster display: "Cruise control system working conditions are not satisfied". After that, ACC can no longer be activated. until the brake temperature drops to a reasonable degree.

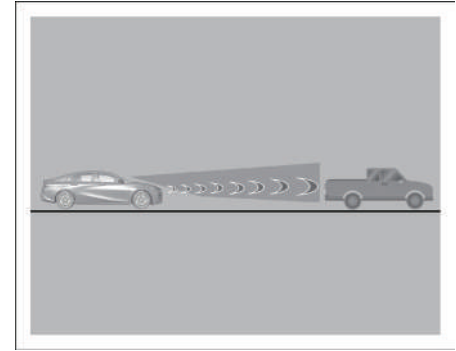

9. ACC should not be used in cities with traffic jams and poor visibility (night/backlighting/rain/snow/dense fog, etc.). ACC may not take braking measures in face of people, animals, narrow vehicles such as bicycles, motorcycles or electromobiles, drop frame trailers, approaching or stationary vehicles, and low-speed or stationary trucks/small pickup trucks, so the driver should be particularly alert and always be ready to take over the vehicle.

### WARNING

- The ACC function cannot cover all driving scenarios and traffic, weather and road conditions.
- The ACC function is only to supplement the driving assistance function, and cannot replace your attention and judgment. It is your responsibility to maintain a safe distance and speed, and you must be ready to intervene if the ACC fails to maintain a proper speed or distance from the vehicle ahead.
- The ACC's takeover prompt alarm only warns the vehicle that has been detected by its radar and camera sensors, so it may not give an alarm, or there may be a certain delay when the alarm is given. Therefore, the driver shall apply the brake as required instead of waiting for the AEB system to operate.

### WARNING

- For the sake of safety, ACC is not allowed to be used in urban driving, traffic congestion, many bends and poor road conditions (such as ice, fog, gravel, heavy rain and water skiing), which is in danger of accidents.
- ACC does not belong to the anti-collision system. If your vehicle is getting closer and closer to the vehicle ahead at a speed higher than that of the vehicle ahead and the braking effect of ACC is unable to stop the vehicle safely before a collision with the vehicle ahead, the driver must depress the brake pedal to reduce the vehicle speed.
- Do not use ACC when driving in roadless areas or on dirt roads. ACC can only be used on flat paved roads such as asphalt and cement.

### WARNING

ACC will make no or limited response to the followings:

- The speed of the vehicle is quite different from that of the vehicle in front.
- Drive in different lanes, change lanes, or curves with smaller radii.
- Pedestrians, animals, bicycles, tricycles, stationary vehicles, etc., or unexpected obstacles.
- Complex traffic conditions.
- Incoming or cross driving on the opposite side.
- Low trailers, trucks or vehicles with irregular/irregular features.

Therefore, be sure to notice traffic conditions and respond accordingly. Do not wait for the system to identify the target or apply the brake, but apply the brake as needed.

## 5. Driving guide

---

### i NOTE

- Never bump against the radar sensor. If the sensor is misaligned due to bumps, it will deteriorate the system performance and even cause the system shutdown even through maintenance and correction are made.
- If the surface of the radar or camera sensor is dirty or covered by heavy rain, ice and snow, mud, etc., the ACC may not function, and the instrument display prompts "Please check the cruise control system". After cleaning the dirt on the sensor surface, the function will return to normal again.
- Please do not spray car paint on the front bumper at will, which may cause the degradation of MRR's performance.
- ACC will not respond to people, animals and vehicles crossing laterally or driving towards the vehicle in the same lane.

### i NOTE

- When passing through intersections, speed bump roads, steep roads, zebra crossings, or driving on changing lanes, highway entrances and exits, ramps or construction sections, it is necessary to exit the ACC system and adopt the manual driving to avoid traffic accidents caused by the automatic acceleration of the vehicle to the set speed under these circumstances.
- The ACC system enables the vehicle to drive out automatically after the vehicle is stopped for a short time or after obtaining the driver's confirmation (control button or accelerator pedal). During this period, the driver must ensure that there are no obstacles or other traffic participants directly in front of the vehicle, such as driving car/two-wheeler.
- If the ACC fails to function normally, do not continue to use it. It is recommended to go to the GAC Motor sales outlet for maintenance in time.

### i NOTE

- ACC may not respond under certain circumstances. For example, the system may not respond when a vehicle approaches a stationary obstacle such as a broken down vehicle or a vehicle waiting in a traffic jam, or a vehicle traveling in the same lane approaches the vehicle.
- ACC can only achieve limited braking force, not emergency braking.
- Do not put your foot on the accelerator pedal unintentionally, otherwise ACC will no longer brake the vehicle. Because the driver steps on the accelerator pedal to refuel may cause excessive speed and distance control.
- When the vehicle is driving in heavy rain or snow and the system is difficult or unable to identify the vehicle in front, ACC shall be turned off.



### **i** NOTE

- When ACC is enabled, the ACC status displayed on instrument cluster display may be overwritten by other functions (for example, during telephone calls).
- After ACC is activated, when the system automatically applies braking to the vehicle, there will be a sound different from manual braking, or the brake pedal will automatically press down, which is a normal phenomenon. This sound and pedal actuation are caused by the operation of the brake system. There is no need to worry.
- For safety reasons, the stored cruising speed will be deleted after the vehicle power supply is turned off.
- You can step on the accelerator pedal at any time to increase the speed. When the accelerator pedal is released, the system will adjust the vehicle speed back to the previously stored vehicle speed.
- Entering the tunnel may put the radar and camera into blind mode, and the ACC may be temporarily switched off.

### 5.4.3 Traffic Jam Assist (TJA)/ Integrated cruise assist (ICA)\*

The integrated cruise assist, referred to as ICA, can automatically adjust the distance from the vehicle ahead during cruising, and keep the vehicle in the middle of the lane, and apply the cruising speed of 0~130 km/h.

ACC detects the relative distance and speed with the vehicle ahead in the same path according to the signals from the MMW radar installed on the front of the vehicle and the IFC installed on the front windshield, and detects the lane marking through the IFC.

ICA can improve driving comfort and provide a more relaxing driving experience, such as during long-distance driving in smooth traffic on a highway.

### **i** NOTE

Precautions for use of radars and cameras.  
=> See page 242

### Operation instruction

- ICA has a strong correlation with ACC. When learning to use ICA, you shall read the relevant chapters of ACC at the same time. => See page 202

### **i** NOTE

- The cruise mode can be switched when ACC is on or activated.
- When ICA has a specific fault that does not affect ACC, the cruise mode will automatically jump back to the ACC. At this time, the driver cannot choose to enter the TJA/ICA mode, but ACC can still be used normally.
- The system has a cruise mode memory function. After the vehicle is started, the cruise mode will be the same as the choice when the vehicle was turned off last time.

## 5. Driving guide



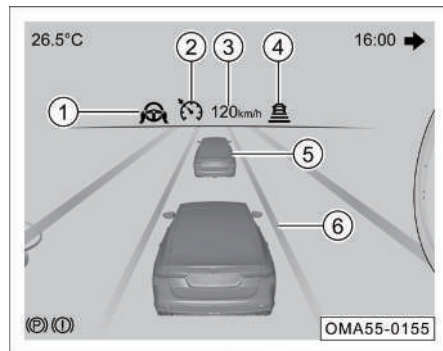

### Interface description



- ① Indicates the steering assist control state and the driver's hand-held steering wheel state:
  - The middle steering wheel icon turns green when the steering assist control is activated, and white when standby.
  - The hands icon on the steering wheel icon is always on when the driver is holding the steering wheel.
  - The hands icon flashes when the driver's hands are detected to be off the steering wheel.
- ② ACC indicator lamp
- ③ Stored cruising speed
- ④ Set cruising distance from the lead vehicle

- ⑤ Detected lead vehicle
- ⑥ Lane marking
  - The lane marking is displayed in gray when not detected by the system, and white when being detected by the system.
  - The lane marking is displayed in green when the ICA steering assist control is activated or when the LKA steering corrective adjustment functions.
  - It will turn red if LKA gives an alarm.

### Activating ICA

Press , then the ACC indicator lamp turns from white  or  to green. The steering assist indicator lamp also turns from white  to green , indicating that ICA is on. At this time, both the ACC and steering assist control of the system are activated.

The steering assist depends on the lane markings set on the road surface. The steering assist indicator lamp may still be white after the ICA switch is pressed. After the system detects a valid lane marking, the steering assist will be automatically activated and the steering assist indicator lamp will turn green.

Please pay attention to the following operations before you enable ICA; otherwise, the function cannot be enabled, and meanwhile, a text indication that working conditions of the system are not met pops up on the instrument panel.



- Close all doors properly.
- Fasten the seat belt.
- Set the gearshift lever to D position.
- Release the brake.

### NOTE

For more precautions, see ACC => See [page 202](#).

### ACC and ICA switching

You can choose to use ACC or ICA. ACC only helps you control the speed, and ICA helps you control the speed and steering at the same time.

The steering assist indicator lamp  on the instrument panel is on, indicating that the system is currently in ICA mode. Press the  button on the steering wheel and the steering assist indicator lamp will be off, indicating that the system has been switched to ACC. At this time, only the speed assist is reserved, and no steering assist is done; Press the  button on the steering wheel again. Then the steering assist indicator lamp will come on, indicating that ICA has been activated. At this time, the speed assist and steering assist are on at the same time.

### Deactivating ICA



The ICA can be deactivated (both speed assist and steering assist are deactivated) as follows:

- Step on the brake pedal.
- Press the ICA switch  on the steering wheel.
- Further operations are the same as deactivation of ACC. Refer to the section ACC for details => [See page 202](#)

### Interrupting steering assist

The steering assist of ICA can be temporarily interrupted through the following operations:

- Step on the accelerator pedal to the floor quickly.
- Turn the steering wheel.
- Turning on the turn signal lamp.
- The hazard warning lamp is turned on.

With the above operation, the steering assist indicator lamp on the instrument panel turns from green  to white , indicating that the steering assist has temporarily been deactivated. After the above operation is stopped, the steering assist will automatically resume when the conditions are met.

## 5. Driving guide

### Steering assist

In ICA mode, the steering assist is automatically activated when valid lane markings are detected and ACC is on.

The steering assist will keep the vehicle moving in the center of the lane markings on both sides.

Steering assist is interrupted when:

- Lane marking is of high curvature or missing.
- Hands-on reminder given by the system when both hands are off the steering wheel for a long time.
- The vehicle speed is too high.

#### **i** NOTE

When the steering assist functions, the driver can still turn the steering wheel to control the vehicle. When the torque applied by the system is found improper, the driver can control the vehicle to travel according to his intention when required.

### Hands-on detection and reminder



Please take over the steering wheel immediately

OMA55-0156

When the ICA detects that the driver's hands have been off the steering wheel for a long time, the instrument cluster will display the alert message "Please hold the steering wheel by hands". If the driver still does not take over the steering wheel, the alert will be upgraded, the hands icon on the steering assist indicator lamp will flash, and a text prompt will pop up at the same time. At that time, on the instrument cluster, the above picture will be displayed, accompanied by an alarm sound.

The driver shall immediately hold the steering wheel immediately after receiving the hands-on reminder. Don't panic or turn the steering wheel fiercely. After ICA recognizes that the driver is holding the steering wheel by

detecting the torque manually applied to the steering wheel, the hands-on reminder disappears. ICA automatically reactivates the steering assist.

#### **i** NOTE

- After the steering wheel takeover alert is issued, if the driver does not take over the steering wheel for a period of time, the steering assist of the ICA function will be interrupted.
- The condition that the driver's hands are lightly holding on the steering wheel may be misinterpreted by the system as the steering wheel out-of-hand. In this case, when the system issues a steering wheel takeover alert, the driver only needs to hold or shake the steering wheel slightly, and the takeover alert will be canceled.

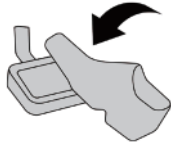

Please take over the steering wheel immediately

OMA55-0157

The ICA system can only apply limited braking capability of the service brake system. When the system requires the driver to intervene in braking, the above figure will be displayed on the instrument cluster, accompanied by an alarm sound.

When receiving the hands-on reminder, the driver shall immediately depress the brake pedal for proper braking.

After the brake pedal is depressed, ICA will be turned off. If the emergency is eliminated and ICA needs to be turned on again, press the ICA switch or resume button. => See page 202

### Limitations

The steering system and brake system capabilities that can be applied by ICA is limited, so ICA cannot maintain a proper vehicle safety distance in all road conditions, nor can it keep the vehicle in the lane in all road conditions.

ICA may incorrectly detect the lane marking or fail to detect the lane marking, and may incorrectly detect the target vehicle or fail to detect the target vehicle ahead.

Even if the ICA system is turned on and has been activated, the system may be affected, mistakenly operated or inoperative under the following conditions:

- Poor line of sight, such as snow, rain, fog or water spots.
- The windshield glass is dirty, damaged, foggy, or there is a blockage in the camera area.
- Overtemperature around the camera due to direct sunlight.
- Direct sunlight, oncoming car lights, and reflected light from accumulated water on the road, etc. lead to poor vision.
- Dramatic changes in lighting conditions, such as entering/exiting tunnels.
- Poor night lighting conditions.
- Special lane marking colors, like in construction areas.
- Unobvious lane markings, such as too thin, worn, blurred or dirt/braking mark/snow/water-covered ones.
- No lane marking, or lane marking color similar to road surface or curb color.
- Isolation strips or other objects cast shadows on the lane marking.
- Close distance from the vehicle ahead or partial or all lane markings blocked by the vehicle ahead.
- Lane markings blocked by construction facilities, etc.
- There are marks or objects similar to lane markings on the road, such as brake marks, other signs printed on the road surface, road edges, lane joints, etc.
- Increase or decrease in lanes.
- Complicated routing of lane markings.
- More than two lane markings on the left and right sides of the vehicle.
- Too wide or narrow lanes.
- Short-term change of marking, such as ramp entrance and exit.
- High curvature or dramatic change (such as at an S-bend) of lane marking.

## 5. Driving guide

---

- Driving on steep slopes or inclined or curved roads.
- Bumpy, icy or waterlogged roads.
- Severe shaking of the vehicle.
- The speed assist of ICA is the same as that of ACC. For more limited working conditions, please refer to the relevant chapters of ACC => [See page 206](#).

The lateral assist control performance of TJA/ICA may be affected under the following conditions:

- Vehicle overload.
- Abnormal tire pressure.
- Uneven road.
- Strong crosswinds.
- Modification of vehicle control-related parts by the driver.
- Replacement of vehicle control-related parts with non-genuine parts.
- Improper assembly of vehicle control-related parts.



### WARNING

- **The ICA is only a driving assistance function, which can not deal with all road, traffic and weather conditions. The driver is always fully responsible for driving, and should always pay attention to the road conditions and actively control the vehicle.**
- **Before using the ICA, the driver must read through all chapters on this function in the user manual to understand the system limitations.**
- **The integrated cruise assist is not a collision avoidance system. When TJA/ICA does not take proper control, the driver must intervene.**
- **Compliance with traffic safety regulations, and safe and civilized driving are always the responsibility of the driver, even if the integrated cruise assist system is being used.**



### WARNING

ICA has limitations. Example:

- **Inclement weather, lane marking damage and many other reasons may cause missing or false identification of lane markings, so that no steering assistance or unnecessary steering assistance is generated when needed.**
- **Integrated cruise assist can only use limited vehicle steering system capabilities, so it cannot cover all driving conditions.**
- **Integrated cruise assist does not work in all traffic situations. When the curvature of the lane marking is too high before the sharp bend, or when encountering a road section without lane marking, the lateral assist may suddenly be deactivated.**

### WARNING

- The integrated cruise assist cannot cover all driving conditions and cannot replace the driver. The driver must hold the steering wheel all the time to actively control the vehicle. When ICA does not provide proper assist or provides improper assist, the driver shall intervene timely.
- Misuse of the integrated cruise assist or negligence may cause an accident, and the driver is always fully responsible for driving, even if the integrated cruise assist is being used.
- The driver needs to judge whether the operating conditions of ICA can be met in certain traffic environments. Under conditions such as urban traffic, crossroads, water-logged or snowy roads, adverse weather, mountain roads, rough roads and highway access, it is recommended not to use ICA. Do not use ICA when a trailer is coupled.

### 5.4.4 Speed limit sign identification\*

Traffic sign recognition is abbreviated to TSR. TSR provides the driver with speed limit information by detecting speed limit signs ahead on the road through the IFC installed on the front windshield and combining with data from the navigation of the AV system, and alerts the driver to overspeed when the speed limit is exceeded.

#### On and Off



Access the AV system interface, switch to the “System Settings → Driving Assistance → Longitudinal Driving Assistance” interface, and press  soft button on the right of “TSR” ① to activate or deactivate the TSR.

After this function is turned on, when there is a speed limit sign on the road, the instrument cluster will display the speed limit sign. When the actual vehicle speed is slightly higher than the speed limit, the speed limit sign of the instrument cluster will flash continuously.

### NOTE

The system has a button state memory function, so that when the vehicle is restarted, the system will work in the state before last shutdown.

## 5. Driving guide

### Description of display interface

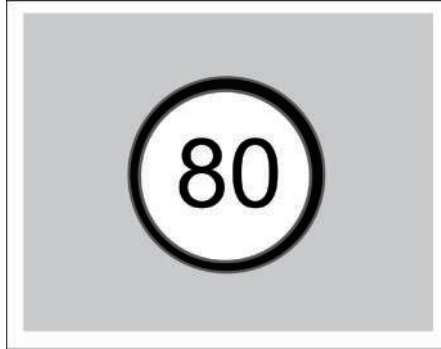

A normal speed limit is identified, including but not limited to general speed limit sign, combined speed limit sign, divided lane speed limit sign, electronic eye speed limit, and interval speed limit.

### Function limitations

The TSR, even activated, may involve wrong or failed detection of speed limit sign due to inevitable environmental factors and conditions. The system may become affected or inoperative under the following conditions:

- The camera is blocked or disturbed by strong light.

- The headlamp is not turned on or cannot fully illuminate the speed limit sign at night or when the light is low in tunnels.
- The speed limit sign is partially or completely blocked.
- The speed limit sign is worn, blurred or dirty.
- The speed limit sign is not properly placed, such as involving twisting or tilting.
- The speed limit sign is obstructed by vehicles in the adjacent lane or obstacles.
- The speed limit has been changed due to temporary road construction.
- Navigation data is not updated online in a timely manner or accurate.
- Other guide boards are misidentified as speed limit signs due to the non-standard road.
- Road speed limit information for other vehicles is output due to inaccurate navigation and positioning.

### WARNING

- The TSR function can identify vehicle speed-related signs only.
- The TSR can only identify the maximum speed limit of the road. Do not rely on TSR to determine the appropriate driving speed. Always drive within the safe speed range according to the speed limit and road conditions.
- If the TSR cannot work under all conditions, the driver shall always bear the ultimate responsibility for the safe driving of the vehicle and comply with applicable laws and road traffic rules.



### 5.4.5 Intelligent speed limit\*

Intelligent speed limit adaptive cruise control is abbreviated as ISLACC. When there is a speed limit sign on the front path, ISLACC sends an alert of synchronization with target cruising speed through the information of TSR, and the driver chooses whether to synchronize the vehicle speed with target cruising speed.

#### On and Off



Access AV system “System Setup → Driving Assistance → Longitudinal Driving Assistance → ISLACC” interface, click soft button ① to enable or disable the ISLACC.

When this function is enabled, the TSR function is enabled synchronously; After this function is turned off, the TSR function remains in the previous state.

#### NOTE

The system has a button state memory function, so that when the vehicle is restarted, the system will work in the state before last shutdown.

#### Triggering requirements of ISLACC speed limit alerts

To trigger the speed limit alert of ISLACC, the following requirements shall be met:

- ISLACC is on.
- ACC is working.
- The difference between ACC current target vehicle speed and TSR speed limit is greater than the system set difference.
- The TSR identifies the speed limit sign for the first time or the vehicle speed changes after the speed limit sign is identified.

After the ISLACC speed limit alert is triggered, the driver will be alerted about whether to synchronize with the current TSR within the next 5s.

#### ISLACC synchronization of target cruising speed

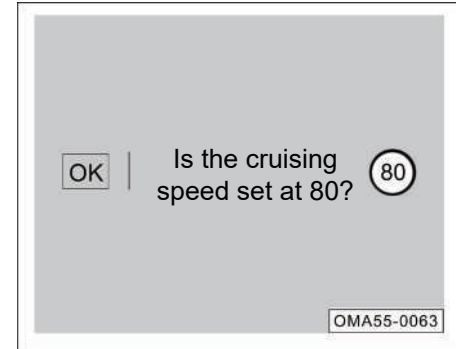

When the pop-up text prompts “Cruising speed set to”, “Current speed limit sign” and “OK” appear on the instrument panel:

1. When the driver presses the OK button, indicating that the driver accepts synchronization with speed limit, the ACC target vehicle speed will be set to the current speed limit.
2. When the driver does not operate the OK button 5s after the prompt message appears, it means that the driver does not accept the synchronization with speed limit, and the target speed of the ACC will remain unchanged.

## 5. Driving guide

### 5.4.6 Forward collision mitigation (FCM)\*

The FCM assesses the danger level of pre-collision by detecting the relative distance and speed with the vehicle ahead in the same path according to the signal from the MMW radar installed on the front of the vehicle and the IFC installed on the front windshield and the driver's other operations (such as depressing the brake pedal or accelerator pedal), gives an alarm to remind the driver to take measures in time in case of a collision risk, and applies the brake automatically when an impending collision is detected. When the driver is braking while the braking force is insufficient to avoid a collision, the system will automatically increase the braking force to avoid or alleviate the collision.

#### Detectable objects:



- Vehicles
- Two-wheelers
- Pedestrians

#### **i** NOTE

Refer to precautions for use of radars and cameras. => See page 242

#### FCW

FCW issues an alarm for impending collision to alert the driver by detecting objects ahead according to the signal from the MMW radar installed on the front bumper and the IFC installed on the front windshield.

The FCM alerts the driver by the following three methods:

#### 1. Distance warning

When the distance warning of FCM is triggered, the FCM indicator lamp on the instrument cluster  flashes, and there is a corresponding animation on the instrument panel.

#### 2. Proximity warning

When the FCM warning is triggered, the FCM indicator lamp  on the instrument cluster flashes, accompanied by an alarm sound and animation prompt.

#### 3. Brake jerk warning

- When the vehicle has a high risk of colliding with the moving target vehicle, brake jerk is triggered to remind the driver that the brake shall be applied immediately.

### Active brake assist

When a collision is about to occur, the system will issue an alarm to alert the driver that the vehicle is ready to apply emergency braking according to the signal from the MMW radar installed on the front bumper and the IFC installed on the front windshield, and then will assist in braking and activate the active brake assist function.

### AEB braking level

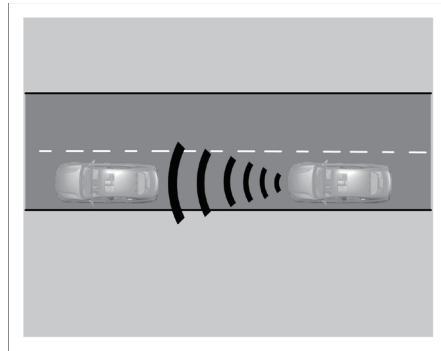

- First-level braking: Brake jerk warning is provided when the ego vehicle is approaching the lead vehicle.

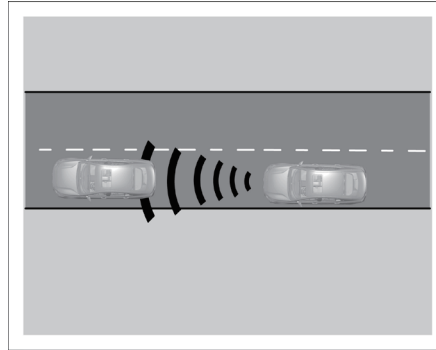

- Second-level braking: Slight automatic emergency braking is applied if the ego vehicle continues to approach the lead vehicle.

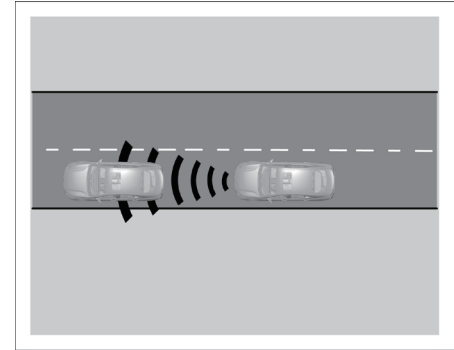

- Third-level braking: Full braking is applied automatically when a rear-end collision is inevitable.

## 5. Driving guide

### On and Off



- When the vehicle power switch is in “ON” position, the FCW and AEB are automatically turned on.
- Turn on or off FCM and AEB through the AV system “System setting → Driving assistance → Longitudinal driving assistance”.
- When the FCW and AEB are turned off, a secondary confirmation window will pop up on the multi-function touch screen. At that time, click “Confirm” or “Cancel” to confirm the switch operation.

### i NOTE

- Access the AV system “System Setup → Driving Assistance → Longitudinal Driving Assistance → FCW distance” and set “Far, Medium and Near”. The FCW distance has a memory function to remember the last set warning distance.
- When the FCW and AEB are turned off, the system will no longer warn the vehicle and pedestrian targets or brake the vehicle.
- After the FCW or AEB is turned off, the vehicle power switch is set from the “OFF” position to the “ON” position again, the FCW and AEB are automatically turned on by default.

### ⚠ WARNING

- The FCM can improve the driving safety, but it is still subject to the limitations of laws of physics, and thus shall never be used for risky driving. The driver must always be ready to apply the brake to reduce the vehicle speed or avoid obstacles.
- The FCM only provides warning and collision mitigation for vehicles/pedestrians detected by the radar and camera, so there may be no response or a certain delay in the response. Therefore, the driver shall apply the brake if necessary instead of waiting for the FCM to operate.
- The FCM only provides the driver with warning to avoid collision and limited braking to mitigate collision injuries, and cannot prevent a vehicle accident or injuries on its own. The driver must always keep control of the vehicle and take full responsibility for the vehicle speed and the distance from other vehicles.

### WARNING

- When the FCM is turned on, the driver must always keep control of the vehicle during driving, and take full responsibility for the speed of the vehicle and the distance from other vehicles.
- Never ignore the illuminated warning lamp and instrument display reminders, otherwise traffic accidents and serious injuries may occur.
- Therefore, be sure to pay attention to traffic conditions and do not rely too much on AEB. The AEB is only a driving aid. The driver should be responsible for keeping a proper distance from the vehicle in front, controlling the vehicle speed and braking in time. The driver must always be ready for braking or steering.

### WARNING

**The active brake assist function must be deactivated when**

- The vehicle is towed.
- The vehicle is on the chassis dynamometer.
- The radar sensor or camera sensor is faulty.
- The radar sensors are under external force (such as in case of rear-end collisions).

### NOTE

- Pressing the accelerator pedal or turning the steering wheel will terminate the FCW alarm and AEB brake intervention.
- In complex driving situations (for example, when the vehicle is running on a circuitous road), FCW and AEB may implement unnecessary alarms and brake interventions.
- When the AEB is triggered, the vehicle will be braked, and the brake pedal may vibrate or become hard, which is a normal phenomenon.
- When affected by factors such as electromagnetic field interference, target's own reasons or environment, the detection will be disturbed and the performance will decline.

## 5. Driving guide

---

### System limitations

FCM has physical limitations and system limitations. For example, FCW and AEB may be triggered inadvertently or with a delay due to interference by the driver in some cases. Therefore, the driver shall stay vigilant and take over control of the vehicle if necessary.

The FCM may work after a certain delay or fail to work when:

- The ground clearance of vehicle ahead is large, such as a semi-trailer.
- The rear of vehicle ahead is low, such as a low bed trailer.
- The vehicle ahead has an irregular shape, such as a tractor or a sidecar.
- The brightness of surrounding environment changes abruptly, such as tunnel entrances and exits.
- The rear of vehicle ahead is small, such as an unladen truck.
- A detectable object ahead performs emergency acceleration, deceleration and steering.
- A detectable object ahead is suddenly driven in front of the vehicle.
- There is a bicycle with a special shape ahead, such as a tandem bicycle.
- The vehicle is driven at a very high speed.
- The vehicle is driven on a slope.
- The vehicle is running on a narrow curve.
- The accelerator pedal is depressed to the floor or the vehicle accelerates rapidly.
- The assist function is deactivated or operates abnormally.
- The ESP is manually deactivated.
- The ESP control is activated.
- The surface of area where IFC is located or the radar sensor surface is dirty or covered by foreign objects.
- The vehicle is reversing.
- Traffic is chaotic.
- The vehicle is towing another vehicle.
- A pedestrian is standing on a refuge island or a curve.
- A pedestrian is completely or partially covered by other objects, such as a worker holding a ladder or a pedestrian holding an umbrella.
- Pedestrians wear strange clothes or masks, for example, carnival costumes.
- External conditions such as sunset, night, ice, snow, heavy rain, fog and backlight lower the visibility.

If a collision is impossible, the system may work when

- There is a detectable object in front of the vehicle.
- The vehicle is overtaking a vehicle that is changing lanes or turning right/left.
- The vehicle is overtaking a vehicle that is ready to turn right/left.
- There is a detectable object at the entrance of a curve.
- The vehicle changes lanes while overtaking a detectable object.
- The vehicle approaches a detectable object ahead while running on a winding lane or changing the driving route.
- The vehicle runs under portal frames, billboards, road signs, etc.
- There are metal objects such as manhole covers and steel plates in front of the vehicle.

- The vehicle approaches a roadside telegraph pole, railing, tree, etc.
- The vehicle runs over grass, branches, banners and other objects that may come in contact with it.
- The vehicle runs near an object reflecting radio waves.

### 5.4.7 LKA\*

LKA is to reduce accidents due to unintentional lane departure.



LKA detects lane markings and road edges through a camera mounted on the front windshield, and detects road guardrails, etc., through MMW radar mounted on the front of the body. In addition, it analyzes the driver's driving behavior and car movement status. When the driver unconsciously makes the vehicle deviate from the lane due to fatigue, distraction, or a phone call, the system issues a warning or intervenes in turning of steering wheel to assist in corrective steering adjustment. It usually gives a warning or interferes with the steering wheel when the front wheel crosses a lane marking.

The system monitors the torque on the steering wheel when the driver sets the assist mode to "Steering" or "Steering and Warning" and the LKA working conditions are reached. When the driver keeps his hands off the steering wheel for a long time, the system will alert the driver.

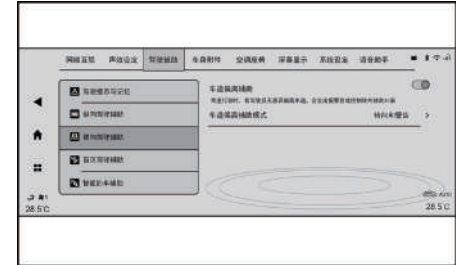
### On and Off



With the vehicle power switch set to "ON" position or the vehicle started, select "Lane Departure Warning" through "System Settings → Driving Assistance → Lateral Driving Assistance" interface in AV system, and press the right  soft button to activate or deactivate the system.

When the system is turned on, the soft button switch on the AV system interface changes to the on state, and the indicator lamp  on the instrument cluster lights up; When the system is turned off, the soft button switch is in off state and the state indicator lamp  on the instrument cluster goes out.

## 5. Driving guide

### **i** NOTE

The system has a button state memory function, so that when the vehicle is restarted, the system will work in the state before last shutdown.

### Selecting LKA mode

When the vehicle power switch is in "ON" position and the LDW is turned on, access the AV system "System Settings → Driving Assistance → Lateral Driving Assistance → LKA mode" function and select LKA mode.

1. Steering assist
  - When "Steering" is selected, the system only intervenes in turning of steering wheel for corrective steering adjustment.
2. WARNING
  - When "Warning" is selected, the system only works for alarming.
3. Steering and warning
  - When "Steering and Warning" is selected, the system will not only issue a warning but also intervene in turning of the steering wheel for corrective steering adjustment.

### **i** NOTE

The LDW has the lane keeping assist mode memory function, so the lane keeping assist mode before last shutdown will be selected when the vehicle is restarted.

### How it alerts the driver

The lane departure warning is only activated when "Warning" or "Steering and warning" has been selected as the LKA mode.

- When the instrument indicates the vehicle speed of greater than 65 km/h and the system detects at least a valid lane marking on one side, the  indicator lamp of the instrument cluster will turn green. It indicates that the system may issue a lane departure warning in this case. When only the edge of one lane is detected, the system will only warn for that side.

When the indicator lamp  turns green, the system may not issue a warning if the vehicle departs from the lane under one of the following conditions.

- The accelerator pedal is quickly depressed.
- The brake pedal is slammed for deceleration.
- The corresponding turn signal lamp is turned on.
- The hazard warning lamp is turned on.
- The driver quickly turns the steering wheel.
- The time from the last alarm is short.
- The vehicle is rolling on or crossing over the lane marking.



When the state indicator lamp  is green, if there is no action mentioned above, and the vehicle deviates from the lane (for example, the vehicle deviates unexpectedly from the lane due to driver's fatigue, distraction, or a phone call), the system sends a warning to the driver, and displays the lane marking prompt through the instrument cluster, accompanied by an alarm sound.

### Steering assist

The corrective steering adjustment prompt of LKA is only triggered when the assist mode is "steering assist" or "steering and warning", and the steering assist is mainly corrective steering adjustment.

When the instrument displays the vehicle speed of greater than 65 km/h and the system detects at least one valid lane marking, the green status indicator lamp  of the instrument cluster lights up. This indicates that the system may intervene in turning of steering wheel for corrective steering adjustment. When only the lane marking on one side is detected, the system only works for lane keeping assist to that side.

When the state indicator lamp  is green, the system will not intervene in the steering wheel for corrective steering adjustment if the vehicle deviates from the lane under one of the following conditions.

- The accelerator pedal is quickly depressed.
- The brake pedal is slammed for deceleration.
- The corresponding turn signal lamp is turned on.
- The hazard warning lamp is turned on.
- The driver quickly turns the steering wheel.
- The time from the last alarm is short.
- The vehicle is rolling on or crossing over the lane marking.
- The system alerts the driver to take over the steering wheel because the steering wheel is out of the driver's hands.

When the system intervenes in the steering wheel for corrective steering adjustment, the driver can feel the torque applied by the system on the steering wheel and a lane marking prompt is displayed on the instrument cluster.

### Hands-on reminder



When the LKA detects that the driver's hands have been off the steering wheel for a long time, the system will issue a takeover alert, and the instrument cluster will display an alarm message, accompanied by an alarm sound.

The driver shall immediately hold the steering wheel immediately after receiving the hands-on reminder. Don't panic or turn the steering wheel fiercely. When the LKA monitors the hand torque applied to the steering wheel, it can recognize that the driver holds the steering wheel by hands and the takeover prompt is cancelled. The LKA is automatically reactivated.

## 5. Driving guide

---

### **i** NOTE

The condition that the driver's hands are lightly holding on the steering wheel may be misinterpreted by the system as the steering wheel out-of-hand. In this case, when the system issues a steering wheel hands-on reminder, the driver only needs to hold the steering wheel tightly or shake the steering wheel slightly, so that the system can detect the torque applied to the steering wheel. Afterwards, the hands-on reminder will disappear.

### Other indications

When the system detects a camera failure, the message "IFC sight blocked" will pop up on the instrument cluster.

Usually, it is caused by dirty windshield glass or the camera directly exposed sunlight. The LKA will not be damaged as a result and maintenance is not necessary.

The driver can try to turn on the front windshield washer and wiper for cleaning.

When the system detects a fault, the message "Please check LKA" will pop up on the instrument cluster, and the status indicator lamp  will light up in red.

### **i** NOTE

If the message "Please check LKA" pops up on the instrument cluster, it indicates that the system is faulty. Please go to the GAC Motor authorized shop for maintenance in time.

### Function limitations

Even when the LKA is on and working, due to unavoidable environmental factors and conditions, the system may detect lane markings incorrectly or not at all. The system may become affected or inoperative under the following conditions:

- Poor line of sight, such as snow, rain, fog or water spots.
- Dirty or foggy windshield, or obstruction in front of the windshield camera.
- Overtemperature around the camera due to direct sunlight.
- Glare due to direct sunlight, oncoming traffic, reflected light from road water-logging, etc.
- Sudden changes in outdoor brightness, such as entering/exiting tunnels.
- Headlamp not turned on at night or when the light illumination is low in tunnels.
- No lane marking, or difficulty in distinguishing the lane marking color from the road surface color.

- Unobvious, too thin, worn, blurred or dirt/snow-covered lane markings.
- Too wide or narrow lanes.
- Increase or decrease in lanes, or complicated routing of lane markings.
- More than two lane markings on the left and right sides of the vehicle.
- Marks or objects similar to lane markings on roads.
- Isolation strips or other objects casting shadows on lane markings.
- Short-term change of marking, such as ramp or highway exit.
- Driving on steep slopes or curved roads.
- Close distance from the vehicle ahead or lane markings blocked by the vehicle ahead.
- Severe shaking of the vehicle.

Under the following conditions, the performance of the system may be affected while it intervenes in turning of steering wheel for corrective steering adjustment:

- Vehicle overload.
- Abnormal tire pressure.
- Uneven road.
- Strong crosswinds.
- Any part involved in vehicle control is modified or replaced with a non-genuine part.
- Improper assembly of vehicle control-related parts.

### **i** NOTE

When the LKA intervenes in turning of the steering wheel for corrective steering adjustment, the driver may still turn the steering wheel to control the vehicle. When the torque applied by the system is found improper, the driver can control the vehicle to travel according to his intention when required.

### CAUTION

- When the LKA detects an unconscious departure from the lane, it will issue a warning or intervene in the steering wheel for corrective steering adjustment. Neither panic nor turn the steering wheel fiercely.
- When the LKA detects that the driver's hands have been off the steering wheel for a long time, it will give a warning. Do not panic, or hit or shake the steering wheel unnecessarily. and instead, please hold the steering wheel and drive the vehicle as usual.
- When you set the LKA mode to "Warning", the system will not make steering intervention. When you set the mode to "Steering", on the instrument panel, one side of the lane marking will turn green, and there will be a graphic and text prompt.

## 5. Driving guide

---

### WARNING

- The LKA is only an auxiliary system and cannot actively control the vehicle to change lanes or stay in a lane. It is the driver's responsibility to always be aware of the road conditions and to actively control the vehicle. So please always keep your hands on the steering wheel and actively control the vehicle.
- Improper or careless use of LKA may cause accidents. Do not rely on LKA or try dangerous driving with the help of LKA.
- When the system fails to detect the lane marking, or judges that the driver intentionally makes the vehicle deviate from the lane (such as when detecting a fast steering wheel rotation) or when the vehicle speed is less than 65 km/h, even if the vehicle deviates from or leaves the lane, the system will not give a warning or make steering intervention.

### WARNING

- When the LKA gives a warning, do not panic, and do not suddenly turn the steering wheel to prevent loss of control of the vehicle.
- Do not place items that reflect light on the instrument panel, as these items may not only dazzle the driver, but also reflect light to the system camera to affect normal operation.
- Protect the camera against strong impact, moisture or heat; and never remove and refit any part without authorization.
- The lane departure warning system can cause an accident if used improperly or negligently. The driver must concentrate on observing the road and traffic conditions and drive carefully.

### WARNING

- The LKA with road edge recognition also uses the signal from the MMW radar sensor. Care shall be taken that the bumper or body shall not be impacted or modified, otherwise the normal operation of the LKA may be affected.
- Do not color or coat the front windshield with any material not meeting the corresponding specifications. Any additional objects that negatively affecting the sight of the system camera may lead to improper operation of the system.
- The system can only use limited steering capacity, so there is no guarantee that the vehicle will be corrected and back into the lane under any circumstances.

### WARNING

- **The sound inside the vehicle or the noise outside the vehicle may prevent you from hearing the warning sound, so there is no guarantee that you can be reminded of the alarm given by the LKA under any circumstances.**
- **LKA does not always recognize lane markings and lane edges. The system may wrongly identify or even don't identify a lane marking or a lane edge due to bad weather, poor night lighting, water or snow on road, damaged or blurry lane markings, or shade on roads. As a result, there may be missing triggering and false triggering of the function. Therefore, the driver must concentrate on observing the road and traffic conditions and drive carefully.**

### 5.4.8 Intelligent high beam\*

The IHC detects traffic and environmental factors in real time through an IFC on the upper edge of the windshield, and can achieve automatic switching between the low beam and the high beam. For example, if the driver activates the IHC during driving on a road with poor lighting at night, the system will switch on the high beam automatically when it is detected that the operating conditions of high beam are met; the system will switch the headlamp from high beam to low beam when the vehicle meeting or too close following driving is detected.

### WARNING

**IHC is a driver assist function, and it can help you to select the lighting way best suitable for the actual condition. The driver shall always be responsible for manual switching between the high and low beams under the traffic and environmental conditions.**

- **IHC may not correctly identify all driving environments and may not work properly under certain circumstances.**
- **If the IFC is shielded by dirt, stickers, ice, snow and etc., the IHC may not work.**
- **If the vehicle lighting system is changed (for example, the modification of the headlights), the IHC may also be degraded or not work.**

## 5. Driving guide





### Activating IHC



1. When the vehicle power switch is in the “ON” gear, the system can be turned on or off by clicking the  soft button through the AV system “System setting → Body accessories → Exterior light → IHC”.

#### **i** NOTE

This setting has a memory function. After the vehicle is started, the system on-off state will be the same as that the last time the vehicle was turned off.

2. Turn the lamp switch to AUTO position to switch on the automatic headlamp function.
  - After the IHC function is turned on, it is in the ready state and the  indicator lamp on the instrument cluster does not light up.
  - When the auto headlamp turns on the low beam, the IHC function is activated and the  indicator lamp on the instrument cluster is lit in white.
  - When the IHC function is activated and the high beam is requested to be turned on, the  indicator lamp on the instrument cluster remain on in white, and the high beam  indicator lamp is on.

#### Deactivating IHC

- Turn the lamp switch to a position other than AUTO.
- Turn off IHC through the AV system “System settings → Body accessories → Exterior light → IHC”.
- Manually turn off the high beam.
- Shut down the engine.

#### **i** NOTE

- When meeting with non-motor vehicles such as bicycles or electric bicycles, this function shall be turned off in time to prevent dazzling the other party.
- The high beam and headlamp flash functions can be manually turned on and off at any time.
- In the case of heavy fog, rain, etc. which may blur the vision of the driver, a request to turn on the low beam will be initiated.
- The IHC function will be inhibited at low speed or intense driving .
- The IHC function will be inhibited when the driver manually turns on the high beam or headlamp flash function.

#### Disabling conditions of IHC

The high beam will be disabled when:

- The vehicle speed is less than 15km/h.
- The fog lamps are turned on.
- The wiper is turned on and remains in HI gear for a period of time.

- The ambient light is brighter than the threshold.
- A street light, a vehicle ahead or an oncoming vehicle is detected.

In the following cases, the high/low beam switching is inhibited:

- Lateral acceleration or yaw rate is too high.
- The vehicle is in the highly dynamic state (with ABS or ESP activated).
- The instrument cluster displays the vehicle speed of lower than 35 km/h.
- Turning on the turn signal lamp.

### Function limitations

When the IHC is activated, the automatic switching of high beam and low beam may be delayed or even unavailable when:

- The windshield surface in front of the IFC is covered with ice, snow, fog, dirt, sticker or other objects.
- The vehicle is on a dimly lit street with highly reflective objects.

- The vehicle encounters pedestrians and bicyclists on poorly lit roads or roadsides.
- The light of the front oncoming vehicle is blocked by a crash barrier, a high bow-top road fence, a green belt, etc.
- The brightness of the tail lamps of the vehicle ahead is low or does not comply with national standards when the vehicle is following the vehicle ahead.
- The vehicle meets another incoming vehicle in case of an extremely tight turn/ mountain road/low-lying ground.
- The vehicle is running on a slope or a bumpy road.
- The vehicle is running in a heavily rainy, snowy or foggy day.
- The IFC is damaged or its power supply is cut off.

### 5.4.9 BSD system\*

The BSD detects the vehicle in the blind spot and the area behind the blind spot through the MMW radar installed at the rear of the vehicle. If it detects that another vehicle is approaching quickly, the BSD will alert the driver through the visual signal on the exterior rearview mirrors.

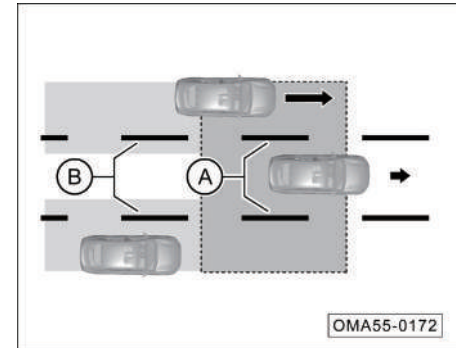



- A: Blind area of view of adjacent lane.
- B: The area behind the blind spot.



## 5. Driving guide

### On and Off



After the vehicle power switch is in “ON” gear or the engine is started, access the AV system “System setting → Driving assistance → BSD driving assistance” press the right  soft button to turn it on or off.

- Click the slider  to turn on or off the BSD.

If the system is turned on normally, the indicator lamp of the exterior rearview mirror will illuminate briefly and the indicator lamp of the instrument cluster  will turn green. If a fault is detected in the BSD system, the indicator lamp  will turn red, and a fault indication will be shown on the instrument cluster display. If the system is turned off, the indicator lamp goes out.

### How it alerts the driver



The BSD alerts the driver via the yellow indicator lamp  on the exterior rearview mirror, whose illuminance can be adjusted automatically according to the ambient light.

#### CAUTION

When the vehicle is started or the system is turned on, the yellow  indicator lamp on the exterior rearview mirror will be on for 2s, indicating that the function is turned on normally.

### Working conditions

During driving (when the vehicle speed is greater than 15 km/h), if the following three conditions occur, the system will give an alarm and the corresponding indicator lamp on rearview mirror will be on:

- another vehicle enters the blind spot from the rear or from one side.
- another vehicle approaches this vehicle quickly from the rear of the adjacent lane.
- other vehicles enter the blind spot from the front and these vehicles stay in the blind spot longer than a certain period of time.

When the system gives a warning and the indicator lamp on rearview mirror of the corresponding side is on, turn on the turn signal lamp on the same side, the indicator lamp flashes, and the system will indicate that lane change is risky.

#### CAUTION

When the vehicle overtakes another vehicle ahead at a very high speed, the alarm will not be activated for the vehicle in the blind spot as the time that the vehicle stays in the blind spot is too short.



### False alarm

When there is no vehicle in the blind spot, the system may give false alarm in the following cases:

- The vehicle is near a road guardrail.
- The vehicle is near a highway concrete wall.
- The vehicle is in a building area.
- The vehicle is passing a sharp turn around a building.
- The vehicle is near shrubs and trees.

#### CAUTION

The false alarm, if triggered, just lasts for a short time and can be corrected automatically.

### Radar sensor

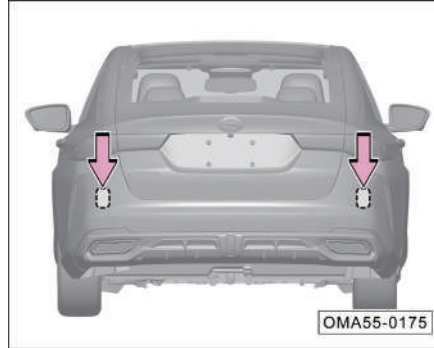

The BSD radar sensors are installed as shown above.

#### CAUTION

Make sure that the area around the rear bumper sensors is not covered by ice, snow or other objects.

If any sensor is interfered, the system performance will be degraded and the instrument cluster will display a prompt “BSD sensor is blocked” and issue an alarm. The system will automatically return to normal if any of the following conditions is met:

- A vehicle is detected on both sides of the vehicle.
- The vehicle is powered off and the engine is restarted.

If the sensor is still interfered when the engine has been restarted, the reminder will be given again and an alarm will be issued. If the message reading “Please check the side assist system” is displayed on the instrument cluster, it indicates that the system is faulty, please go to the GAC Motor authorized shop for inspection in time.

## 5. Driving guide

### WARNING

- **BSD is a driver assistance system that cannot replace the driver to monitor external traffic conditions or make judgments.**
- **In order to ensure safety, the driver must not rely entirely on the BSD radar, and must correctly use the interior rearview mirror and the exterior rearview mirrors on both sides.**

The BSD system may not work properly or even be inoperative under the following special conditions:

- The detected target is too small, such as a bicycle, an electric self-balancing scooter, etc.
- The target is stationary.
- The weather is too severe (such as rain, snow, etc.).
- The vehicle is running on a curved road, a ramp, etc.

### 5.4.10 Rear crossing traffic alert system\*

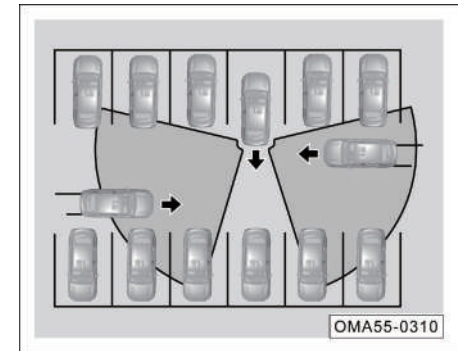



The rear crossing traffic alert (RCTA) system detects blind spots on both sides of the rear of the vehicle via the BSD sensor installed at the rear of vehicle. When the vehicle is reversing, when an approaching vehicle is detected, the system will warn the driver through the visual signal of exterior rearview mirror, instrument alarm sound and the panoramic image.

### WARNING

- RCTA is a driver assistance system that cannot replace the driver to monitor external traffic conditions or make judgments.
- In order to ensure safety, the driver must not rely entirely on the BSD radar, and must correctly use the interior rearview mirror and the exterior rearview mirrors on both sides.

### On and Off

After the vehicle power switch is in the "ON" gear or the engine is started, access the AV system "System Settings → Driving Assistance → BSD Driving Assistance", select "RCTA", and press the  soft button on the right to set it on or off.

When the vehicle is started or the user turns on the function, the rearview mirror  LED indicator lamp will light up for 2s, indicating that the function is turned on normally.

### NOTE

The system has a button state memory function, so that when the vehicle is restarted, the system will work in the state before last shutdown.

### How it alerts the driver

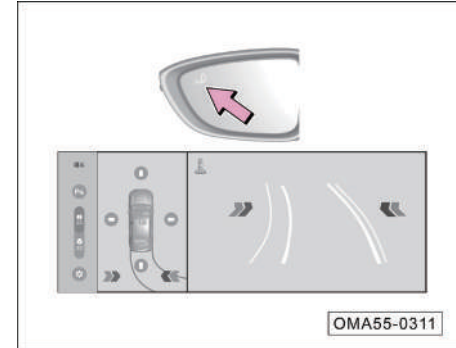

- Visual reminder: The system alerts the driver via the yellow indicator lamp  on the exterior rearview mirror and the red flashing arrow on the incoming vehicle side in the panoramic image. The illuminance of indicator lamp can be automatically adjusted according to the ambient light.
- Audible reminder: There will be an alarm sound as a supplementary reminder at the same time.

The RCTA system alerts the driver via the yellow indicator lamp  on the exterior rearview mirror, instrument audible alarm and the panoramic image. The brightness of indicator lamp can be automatically adjusted according to the external lighting conditions.

## 5. Driving guide

### Working conditions

The preconditions required for activating the function are as follows:

- The vehicle is reversing and the gearshift lever is in "R" position.
- The vehicle speed is lower than 10km/h.
- The vehicle power supply is on, and the function is not faulty.

When the radar detects that the vehicle is reversing and another vehicle is approaching to the vehicle on either side from the rear and may collide with the vehicle, the RCTA will alert the driver in the following way:

- On the side with risk of collision, the yellow indicator lamp  on the exterior rearview mirror flashes.
- In the panoramic image, a red light bar flashes at the rear of the vehicle on the side with risk of collision.
- The system issues an audible alarm as a supplementary alarm.

### CAUTION

The function cannot detect the objects behind other vehicles or obstacles.

### False alarm

When there is no vehicle in the detection area, the system may issue a false alarm in case of the following conditions:

- The vehicle is near a road guardrail.
- The vehicle is near a highway concrete wall.
- The vehicle is in a building area.
- The vehicle is passing a sharp turn around a building.
- The vehicle is near shrubs and trees.
- The vehicle is too close to the vehicle behind during parking.

### CAUTION

The false alarm, if triggered, just lasts for a short time and can be corrected automatically.

### 5.4.11 Door opening warning system\*

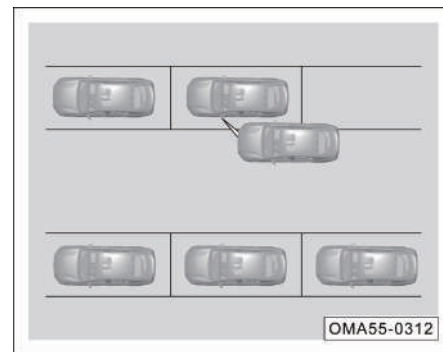

The door open warning (DOW) system uses the BSD sensor installed at the rear of the vehicle to detect the adjacent lane during parking, and when another vehicle is detected approaching quickly and will cause risk of collision if the door is opened, alerts the driver via the visible signal on the exterior rearview mirror and the audible alarm.

### WARNING

- **DOW is a driver assistance system, which cannot replace the driver to monitor external traffic conditions or make judgments.**
- **In order to ensure safety, the driver must not rely entirely on the BSD radar, and must correctly use the interior rearview mirror and the exterior rearview mirrors on both sides.**

### On and Off

When the vehicle power switch is in the "ON" gear or the engine is started, access the AV system "System Settings → Driving Assistance → BSD Driving Assistance", select "DOW", and press the  soft button on the right to set it on or off.

### NOTE

The system has the button state memory function, so that when the vehicle is restarted, the system will work at the state before last shutdown.

### How it alerts the driver



The door open warning system alerts the driver via the yellow indicator lamp  on the exterior rearview mirror. The indicator lamp can automatically adjust the brightness according to the external lighting conditions.



## 5. Driving guide

---

### Working conditions

The preconditions required for activating the function are as follows:

- The vehicle is stationary.
- The vehicle power switch is in the "ON" gear, or is switched from the "ON" gear to the "ACC" or "OFF" gear within 3 minutes.
- The engine is started and the function is normal.

When the radar detects a vehicle behind in the adjacent lane and there is a risk of collision if the driver opens the door, the yellow warning lamp  on the exterior rearview mirror on the danger side will come on. If the driver continues to open the door, the warning lamp  will flash and an audible alarm will be issued.

#### CAUTION

This function cannot detect objects behind other vehicles or obstacles.

### False alarm

When there is no vehicle in the detection area, the system may issue a false alarm in case of the following conditions:

- The vehicle is near a road guardrail.
- The vehicle is near a highway concrete wall.
- The vehicle is in a building area.
- The vehicle is near shrubs and trees.
- The vehicle is too close to the vehicle behind during parking.
- There are larger vehicles behind the vehicle.

#### CAUTION

The false alarm, if triggered, just lasts for a short time and can be corrected automatically.

### 5.4.12 Rear approach alert system\*

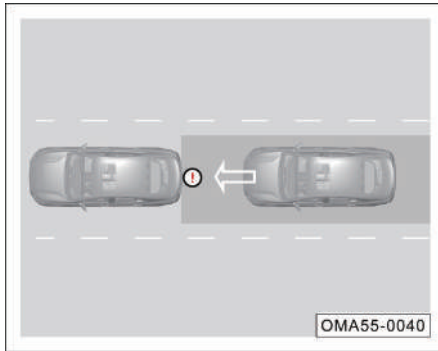

The rear approach alert function monitors the target directly behind the vehicle in real time through the BSD sensor installed at the rear of the vehicle. When the driver drives the vehicle normally on the road and there is a target rapidly approaching in this lane behind, the system will send out an alarm message and a rear-end collision warning signal to the vehicle behind.

#### CAUTION

The rear approach alert function is only for assist and cannot replace the driver to monitor the external traffic conditions. The driver should always be alert to the surrounding environment..

#### On and Off

When the vehicle power switch is in the “ON” gear, access the AV system “System Settings → Driving Assistance → BSD Driving Assistance”, select “Rear approach alert system”, and press the right  soft button to set it on or off.

#### NOTE

The system has the button state memory function, so that when the vehicle is restarted, the system will work at the state before last shutdown.

#### How it alerts the driver

The rear approach alert function automatically activates and quickly flashes the hazard warning lamps to alert the rapidly approaching vehicles behind.

## 5. Driving guide

---

### Working conditions

The preconditions required for activating the function are as follows:

- The vehicle is started and the gearshift lever is in a position other than R.
- The function switch is turned on and the function has no fault.

When the radar detects that there is a vehicle approaching at a high speed in this lane behind, the function will be activated to alert the driver in the vehicle behind to reduce the risk of rear-end collision.

#### CAUTION

- This function cannot penetrate through another vehicle or obstacle and detect objects behind it.
- When the rear vehicle moves too fast, this function may not give an alarm in time.
- This function does not trigger an alarm when the driver has turned on the hazard warning lamp switch.

### False alarm

When there is no vehicle in the detection area, the system may issue a false alarm in case of the following conditions:

- The vehicle is in a parking lot.
- The vehicle is on uneven roads.
- The vehicle is in a building area.
- The vehicle is near shrubs and trees.

#### CAUTION

The false alarm, if triggered, just lasts for a short time and can be corrected automatically.

### 5.4.13 Radar and camera sensors \*

#### Millimeter-wave (MMW) radar sensor

The MMW radar sensor is installed in the middle of the grille under the front bumper to monitor the traffic conditions and detect the front vehicles at a certain distance from own vehicle.

The radar sensor must be adjusted and calibrated under the following conditions:

- The fixing bracket of the MMW radar sensor is removed and refitted.
- The MMW radar sensor is removed and refitted.
- The toe or rear wheel camber is adjusted during the four-wheel alignment.
- The vehicle has a collision.



### NOTE

- Specific special tools and equipment shall be used for MMW radar sensor adjustment and calibration. If the MMW radar sensor needs adjustment and calibration, please go to the GAC Motor authorized shop for relevant operation.
- Inoperative or misadjusted MMW radar sensor can affect ACC, integrated cruise assist, FCM and pedestrian detection system.

### Special considerations on MMW radar sensor

The MMW radar sensor is installed at the front of the vehicle, and no obstacle shall be present in its detection area. Do not install the obstacles such as the license plate frame when installing the front license plate. Otherwise, the performance of MMW radar sensor will be affected, resulting in failure of the ACC, integrated cruise assist, FCM and pedestrian detection.

### CAUTION

- If the MMW radar sensor is dirty, blocked by the license plate frame, or covered by any foreign matters such as heavy rain, ice, snow, mud, the related functions of the radar sensor may not work and the instrument cluster will give disable/fault indication for these functions. To restore these functions to normal, clean the dirt and/or foreign matters.
- When there is strong reflection of the MMW radar ultrasonic wave (e.g: in a car park), related functions of MMW radar sensor may be affected.
- Prevent the front and surrounding of the MMW radar from being covered by objects like sticker, driving assistance lamp, license plate frame, etc.; otherwise the related functions of the radar sensor may be affected.
- It is recommended to use a brush to remove the snow on the sensor surface; It is recommended to use a non-soluble de-icing spray to remove ice from the sensor surface.

### CAUTION

- Maintenance of the front body of the vehicle may cause change in the radar sensor direction and affect related functions of MMW radar (ACC/ICA/FCM). Therefore, please go to the GAC Motor authorized shop for service in time.
- If the MMW radar sensor is damaged or its direction changes, please turn off the related function of MMW radar (ACC/ICA/FCM), and go to GAC Motor authorized shop to recalibrate the MMW radar sensor in time.
- The direction of the MMW radar sensor may change due to vibration, for example, when the area near the front bumper radar collides with the curb/flower bed. Change of the direction of the sensor may affect the performance of the functions dependent on the radar or even cause abnormal deactivation of these functions.

## 5. Driving guide

---

### IFC

An IFC is installed on the upper part of the windshield glass to detect the surrounding environment, which can identify pedestrians up to 80m away from the vehicle when no obstacle is present (in case that the environmental factors such as lighting are ideal) with a height not less than 0.8m. The IFC sensor must be calibrated under the following conditions:

- The windshield or the camera bracket has been removed and replaced.
- The IFC sensor has been removed and replaced.

#### NOTE

If the IFC fails, the systems such as ACC, ICA, LDW, FCW and IHC will fail as well.

#### NOTE

- The calibration of the IFC sensor requires the special tools and equipment. If the calibration of the IFC sensor is required, please go to the GAC Motor authorized shop for relevant operation.
- When the IFC sensor is failed, misadjusted or blocked, the normal use of the ACC, FCM, LDW, ICA, IHB and other functions may be affected.

#### CAUTION

- Poor lighting conditions, night, backlight, heavy rain, mist, ice, snow or sludge may affect the IFC, leading to interruption/performance degradation and even failure of FCM, ACC, ICA, AEB, LKA and IHC. In this case, the instrument cluster will display alarm messages relevant to intelligent driving assistance such as "The MRR is blocked", "The sight of IFC is blocked", "Please check the LKA", "Please check the ACC", "Please check the FCM", etc.

### CAUTION

- The field of view of the IFC may be affected by obstructions, such as dust, sediment, water mist, icing, snow or sludge on the front windshield. In these cases, the LKA, FCM, ACC, ICA and IHC will be disabled. Please wipe the area near the camera on the front windshield, or turn on the defrosting and defogging function of the A/C. The functions can return to normal after the obstructions are cleared.

### CAUTION

- If the IFC interference factor disappears, the pedestrian detection system will work again.
- Low light conditions at sunset or night may affect the pedestrian detection system. Never block the sight around the IFC with stickers or opaque objects; otherwise, the PDS may not work properly.
- Before driving the vehicle, please check whether there is any obstacle in the area around the IFC.
- Maintain clear vision of camera sensor on front windshield glass.

## 5. Driving guide

### 5.4.14 TPMS

The TPMS monitors the pressure and temperature of the tire, and displays them on the instrument cluster. In case of tire anomalies such as low/high pressure, rapid air leakage and high temperature, the instrument cluster will display an alarm message accordingly.

If the vehicle has not been used for more than seven days or the battery has been disconnected, when the ENGINE START/STOP button is in "ON" position, the tire pressure and temperature will be displayed as "---" on the instrument cluster, and after the vehicle speed reaches above 25km/h for several minutes, the real-time tire pressure and temperature will be displayed on the instrument cluster.

#### Alarm description

- When the tire pressure value is higher than 330 kPa, the TPMS indicator lamp will light up, and a warning message "High tire pressure" appears on the instrument cluster display; When the tire pressure is lower than 330 kPa, the fault is eliminated and the tire pressure warning lamp goes out.
- If the tire pressure value is lower than 75% of the normal set value, the TPMS indicator lamp comes on, and the warning message "Low tire pressure" is displayed on the instrument cluster display; When the tire pressure (cold tire) is increased to the normal set value, the fault is eliminated and the tire pressure warning lamp goes out.
- If the tire pressure continuously decreases by more than 30 kPa/min, the TPMS indicator lamp lights up, and the alarm message on the instrument cluster display indicates that the tire has air leakage; The vehicle power supply is switched on again, the fault is eliminated, the tire pressure warning lamp goes out.
- If the tire temperature is higher than 85°C, the TPMS indicator lamp lights up, and a warnig message "High tire temperature" appears on the instrument cluster display; When the tire temperature drops to 80°C, the fault is eliminated and the tire pressure warning lamp goes out.

#### CAUTION

If you replace the tire pressure sensor in the tire or change the tire position, you do not need to go to the company's automobile sales service store for relearning and calibration under the condition of ensuring that the tire pressure sensor conforming to the vehicle model has been correctly installed. The TPMS will automatically complete the learning and calibration in the next few driving cycles.

#### NOTE

If the low tire pressure alarm does not disappear while you continue to drive as the tire pressure sensor is missing when a spare tire or a new tire has been replaced in another place. Please do not interpret that as abnormal tire pressure.

### 5.4.15 On-board ETC unit\*

The ETC communicates with the RSU in both directions to achieve toll collection without stopping. OBU supports open free stream charging transactions and closed import and export transactions. After the transaction, non-repudiation vouchers are generated for applications such as deduction and settlement in the form of back-office bookkeeping.

#### On and Off



Access the AV system interface, switch to the “System settings → Body accessories → Other accessories” screen and press the soft button to the right of “ETC” to activate or deactivate the on-board ETC unit.

After deactivation, the ETC will turn off the 5.8G antenna, and normal automatic charging service will not be available during driving through the expressway toll station.

#### Bluetooth function

- After the vehicle is started, the ETC Bluetooth is turned on for 20min, and the device can be connected through search via the mobile phone APP, and issued and activated remotely; After the Bluetooth operation is completed, the Bluetooth will be automatically switched off with a delay (also off when no operation is done).

#### Self-inspection function

ETC status	Indication by buzzer
Successful transaction	A short sound
Abnormal transaction	Three short sounds
Not OK during self-test	None
Not OK during self-test	A long sound
Not activated	Two short sounds
Bluetooth connected	A short sound

After the vehicle is started, the on-board ETC unit performs a self-test and beeps.

#### Application and activation

Users can use the WeChat applet to search for “Guangdong Access Card ETC” and then activate self-service according to the applet guidelines.

##### 1. Application steps:

Click “ETC application” → “Instant handling” → Enter the license plate number and other relevant information → Upload the front and back pictures of the ID card and driving license → Product collection method page, select “On-site self-collection” → Select the sign bank and enter the bank card information.

##### 2. Activation steps:

Click “ETC Activation” → Find and select the corresponding order → Select “Self-service Activation” → Power on the vehicle again → Click “Get Equipment Information” → Confirm OBU number information → Wait for activation → Upload the picture → Activation is successful.

## 5. Driving guide

### **i** NOTE

- Please log out your ETC account when transferring the ownership of the vehicle.
- ETC activation and transaction can be done only after the ETC system is on.
- ETC activation requires the vehicle to be powered off → powered on to turn on the Bluetooth function of OBU.

### 5.4.16 Cabin monitoring system\*

The cabin monitoring system monitors the facial features and actions of the driver and passengers in the car through two cameras installed in left front of the driver's seat (A-pillar) and the interior rearview mirror cover, respectively, and realizes the following functions: Distraction reminder, fatigue reminder, smart ventilation, call-time sound reduction, sight-wakened screen, track skipping, mood music. In the future, functions such as map moving with gesture, Qimiao camera, photography with gesture, and distraction at expressway intersections will be achieved through OTA.

### **i** NOTE

Some models are equipped with an intelligent cabin. All image information collected by the system will not be saved or uploaded except for the photos actively taken and saved by the people in the vehicle.

### On and Off

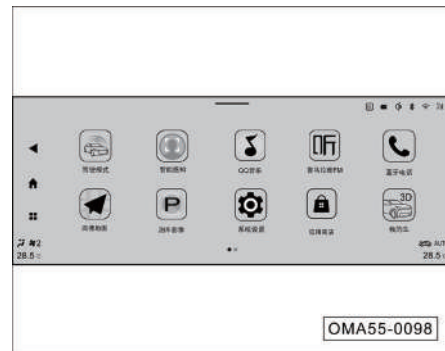

If the vehicle power switch is in the “ON” position or the engine is started, click the “Intelligent Sensing” APP on the multi-function touch screen to access the interface, and activate or deactivate the specific reminder of the corresponding monitoring function through the soft switch.

### Reminder mode

#### 1. Fatigue reminder

The cabin monitoring system can detect following levels of driver fatigue: Mild fatigue, moderate fatigue, severe fatigue.

- When the cabin monitoring system is triggered by mild fatigue, a voice reminder will be issued to warn the driver to drive safely.
- When the cabin monitoring system is triggered by moderate fatigue, a voice reminder sounding "Dear, I noticed that you are very tired. May I play a song for you for refreshing?" will occur, and a pop-up box will appear. When you click OK or the pop-up box is not clicked till timeout, the refreshing music will be played; when you click Cancel, there will be no response.
- When the cabin monitoring system is triggered by severe fatigue, a voice reminder sounding "Dear, you have dozed off. For your driving safety, may I activate the wake-up mode for you?" will occur, and a pop-up box will appear. When you click OK or the pop-up box is not clicked after timeout, the refreshing music will be played, and at the same time, the A/C will be turned on in cooling mode, accompanied by red atmosphere lighting; when you click Cancel, there will be no response.

#### 2. Distraction reminder

- If the cabin monitoring system detects that the driver is distracted, it will remind the driver by voice sounding "Dear, please pay attention".

### **i** NOTE

The voice reminder will not repeat. After the first reminder, the alarm will not be activated again in 6 minutes.

#### 3. Call-time sound reduction

- When the driver is on the phone without using the in-car Bluetooth, the voice sounding "For your safety, please use the in-car Bluetooth for calls" will occur and a pop-up box will appear (and disappear after 5s).
- When the front passenger is on the phone without using the in-car Bluetooth: a pop-up box reading "A comfortable call environment will be provided you" will appear (and disappears after 5s), the volume will be turned down, and the front passenger side anti-pinch window and the sunroof will be closed.
- When both the driver and front passenger are on the phone, and the in-car Bluetooth is in use: a pop-up box reading "As the AVN is in the Bluetooth call state, the media cannot be adjusted temporarily. For your convenience, the windows and

sunroof will be closed now." will appear (and disappear after 5s), and all anti-pinch windows and sunroof will be closed.

- After the call ends, if the media volume is turned down for response before, the windows, sunroof and volume will be restored to the states before. If manual adjustment is performed, they will not be restored.
- #### 4. Sight-wakened screen
- When the screen is in a black state and it is detected that the driver is looking at the screen for more than 1s, the screen will be automatically turned on.
- #### 5. Smart ventilation
- When smoke is detected from the front passenger, an audible reminder "As it is detected that the front passenger is smoking, ventilation will automatically start" will occur and a pop-up box will appear. When you click OK or the pop-up box is not clicked till timeout. If it is not raining and the sunroof is closed, the sunroof will be set to the lifted state, the windows will be opened, the A/C will be turned on and set to the fresh air mode and the plasma mode; when you click Cancel, there will be no response. If it is raining, the sunroof and windows will not respond, while only the A/C will respond.

## 5. Driving guide

---

- After the smart ventilation is triggered, if no smoke is detected for a period of time, the windows, sunroof, and A/C will be restored to their original states.

6. Mood music (this function will be reflected later through the OTA upgrade)

When the driver and passengers wake up the voice assistant and inform that music is needed with no specified song information, the cabin monitoring system analyzes whether the driver's current mood is natural, happy or unhappy according to the facial characteristics of the driver and passengers, then broadcasts the following voices respectively and plays the corresponding type of songs:

- Natural mode: "OK. Dear, the destination of language is music. Enjoy the music now".
  - Happy mode: "Yes. Dear, music is our simplest happiness. Enjoy the music".
  - Unhappy mode: "OK. Dear, music is the cure for all unhappiness. Enjoy it now".
7. Track skipping with gesture

When the music is on, within the visual range of the in-car monitoring camera, if the driver and passengers point their fingers to the front of the vehicle:

- Wave the palm from right to left, so the music will automatically skip to the previous track.
  - Wave the palm from left to right, so the music will automatically skip to the next track.
8. Map moving with gesture (this function will be reflected through OTA upgrade and update later)

When the map is on, within the visible range of the interior monitoring camera, if the driver and passengers point five fingers to the front of the car:

- Slide the palm from right to left, and the map interface switches from the multi-function touch screen to the instrument cluster display.
  - Slide the palm from left to right to display the map interface on the multi-function touch screen.
9. Qimiao camera (this function will be reflected by OTA upgrade and update later)
- Click the icon of Qimiao camera on the multi-function touch screen to access the application

- Select the desired special effects and beautification effects, and take photos through buttons on multi-function steering wheel and static gestures.
- Photos can be downloaded and shared through the <GAC Motor> APP.

### Working conditions

- The face can be clearly detected by the system.
- The system completes the initialization.
- The power supply of the AV system is normal.
- Fatigue, distraction reminder and the reminder on the driver in a call require a speed of more than 30km/h.



### NOTE

- When the cabin monitoring system detects the face or behavior of the driver and passengers, it needs to operate within the effective range of the camera (that is, the camera can clearly identify full face features of the driver and passengers and the behavior above the waist).
- If such identification fails due to an invalid operating range, please adjust the position or posture.

### False alarm

- Conditions where false alarms may occur: The vehicle is in a curve; The driver is in the process of steering; The vehicle enters and exits a tunnel; The camera is blocked.
- In some cases, such as strong direct sunlight on the face, seat or steering wheel adjustment causing facial monitoring loss, etc., the performance may be degraded.
- The system uses an infrared camera, which may be interfered with by some sunglasses, resulting in performance degradation.
- If the camera is interfered, the performance of the system will degrade.

### NOTE

The system will automatically return to normal if any of the following conditions is met:

- The camera re-identifies the driver's facial information.
- The vehicle is powered off and the engine is restarted.

### CAUTION

After the function enters the working mode, due to the characteristics of the fatigue algorithm, the fatigue monitoring system takes 1min to complete the initialization, during which the function will not work.

## 5. Driving guide

---



### WARNING

- **Even if the cabin monitoring system is provided, you are still responsible for concentrating on driving with care.**
- **If you feel tired, please take regular breaks as needed and don't wait for the system to warn you.**
- **Even if you don't feel tired, the system may issue a warning under some special circumstances, such as: Close your eyes continuously for a certain period of time.**
- **The system cannot guarantee accurate identification of every driver, and some drivers' facial features may not be accurately captured.**
- **The system does not recognize the need for a break in all situations.**



### CAUTION

- Please comply with the national road traffic safety laws and relevant implementing regulations to drive safely.
- Do not block the driver monitoring camera on the left front (A-pillar) and the interior monitoring camera above the interior rearview mirror.
- Do not use trim or the like to cover the left A-pillar and the upper cover of the interior rearview mirror, or install any other parts on the left A-pillar and the upper cover of the interior rearview mirror. Covers over the left front A pillar and interior rearview mirror contain sophisticated detection devices. The behavior described above may damage the devices or cause failure to correctly detect the real-time status of the driver.
- The function of the cabin monitoring system relies on clear images of the status of drivers and passengers. In some cases: strong direct sunlight, seat or steering wheel adjustment and rear occupants' faces blocked by front seats will result in incomplete monitoring data of the driver and passengers, and may cause performance degradation.



### CAUTION

- When the driver response function is turned on for detection, it will take some time to complete the initialization, during which the monitoring function will not work.
- Do not drive with fatigue.
- Currently, only some functions are displayed in the smart cockpit. You can go to the APP Mall to update the APP, add new functions, and optimize and upgrade existing functions.
- If the camera is not working, please restart the vehicle after power-off. If the system still cannot work normally, it is recommended to go to the GAC Motor authorized shop for overhaul in time.

### 5.5 PAS

#### 5.5.1 RPA

The RPA uses the radar sensors to send and receive the ultrasonic waves reflected by the obstacle to measure the distance between the vehicle and the obstacle, assisting the driver in parking and adjusting parking space.

#### On and Off

Model with rear radar:

- When the vehicle power switch is in the "ON" gear, release the parking brake and switch the gearshift lever to the "R" gear. When the vehicle speed is less than 10 km/h, the rear ultrasonic sensor enters into operation.
- When the vehicle speed is greater than 12 km/h, the rear ultrasonic sensor is off; Set the gearshift lever to "P" gear, and apply parking brake. After the vehicle power switch is moved out of "ON" gear, the rear ultrasonic sensor is deactivated.

For models with front radar:

- When the vehicle power switch is in the "ON" gear, release the parking brake and set the gearshift lever to the "R" gear. When the vehicle speed is less than 10 km/h, the RPA works.
- When the forward speed is less than 10km/h, the front ultrasonic sensor starts to operate; when the forward speed is greater than 12km/h, the front ultrasonic sensor stop operating; when the forward speed decreases from 12km/h above to below 10km/h, the front ultrasonic sensor starts to operate again.
- When the vehicle speed is greater than 12 km/h, the front and rear ultrasonic sensors are off; Set the gearshift lever to "P" gear, and apply parking brake. After the vehicle power switch is moved out of "ON" gear, the front and rear ultrasonic sensors are deactivated.

#### Dynamic view (for model with rear radar)



The dynamic view appears at the upper left of the display screen, indicating the distance between the rear of the current vehicle and the obstacle. In the view, the outermost sector is green, the middle and innermost sectors gradually turn to yellow and red. When the vehicle is getting closer and closer to an obstacle detected, the colorful sectors will come nearer and nearer to the car icon.

Change of dynamic view is synchronized with that of the distance audible alarm.

## 5. Driving guide

### Dynamic view (for models with front and rear radars)

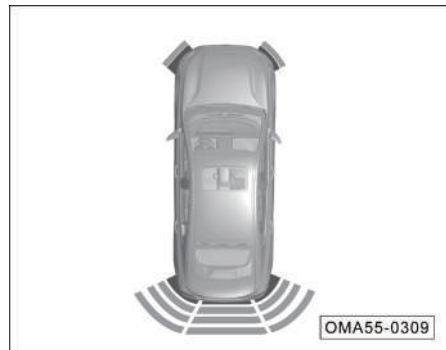

The dynamic view that appears at the upper left of the display indicates the distance of the front and rear of the current vehicle from the obstacle. In the view, the outermost sector is green, the middle & innermost sectors gradually turn to yellow and red. When the vehicle is getting closer and closer to an obstacle detected, the colorful sectors will gradually come nearer and nearer to the vehicle icon.

Change of dynamic view is synchronized with that of the distance audible alarm.

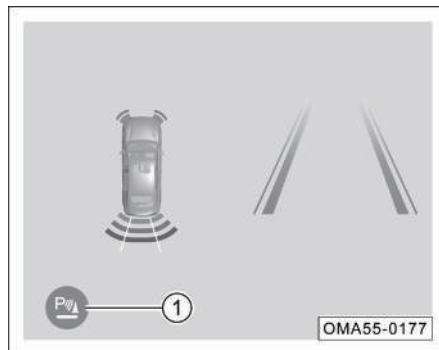

When the RPA is turned on during reversing, press **P** the button ① on the AVM interface to manually turn off the system, and press it again to turn on the system. The RPA will be turned on automatically after the vehicle is restarted.

### **i** NOTE

It is recommended to turn on the RPA sensor during reversing operation.

### **👁** CAUTION

In certain environments, such as during pneumatic braking of large trucks, buses and other large vehicles around, the front radar sensor is affected by other electrical equipment or devices that can produce ultrasonic waves of the same frequency, which may cause false warning or failure within 0.5~1 s.

Distance to detected obstacle					Audible alarm level message
Front left sensor	Left/right front sensor	Rear left sensor	Rear right sensor	Rear middle sensor	
No display & alarm	No display & alarm	90~120cm	90~120cm	90~150cm	Slow and intermittent alarm sound
No display & alarm	No display & alarm	60-90cm	60~90cm	90-60cm	Slow and intermittent alarm sound
30-60cm	30~60cm	30~60cm	30-60cm	30~60cm	Regular rapid audible alarm
< 30cm	< 30cm	< 30cm	< 30cm	< 30cm	Continuous audible alarm

### Distance audible alarm

The audible alarm changes with reference to the distance between a detected obstacle and the front/rear bumper. In addition, the color of activated sector shown on the AV system display changes accordingly.

## 5. Driving guide

### Layout of front radar sensor

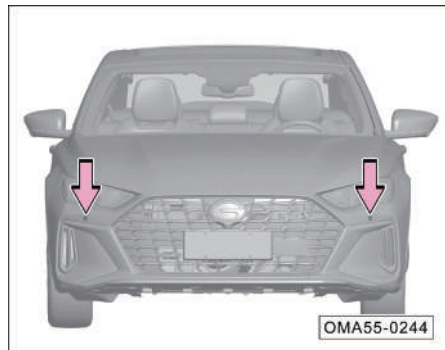

The front ultrasonic radar sensors are installed on the front bumper cover. (for models with transverse grille\*)



The front ultrasonic radar sensors are installed on the front bumper cover. (for models with vertical grille\*)

### Layout of rear radar sensor

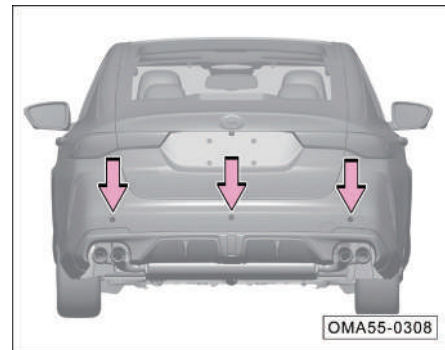

The rear ultrasonic radar sensors are installed on the rear bumper cover. (for models with transverse grille\*)

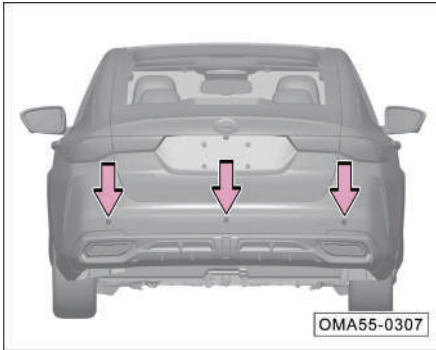

The rear ultrasonic radar sensors are installed on the rear bumper cover. (for models with vertical grille\*)

### CAUTION

- Always keep the surface of the RPA sensors clean and never cover a RPA sensor.
- Keep the RPA sensors clean and protect them from freezing to ensure they operate properly.
- Clean the RPA sensor surface with a piece of soft damp cloth to avoid scratching.

### WARNING

- **The RPA cannot take the place of the driver's observation to the surrounding environment. The driver shall be concentrated and reverse safely according to the actual conditions.**
- **There is a blind spot when radar sensor is detecting obstacles. When reversing, the driver must pay attention to observation to avoid accidents.**
- **When the vehicle is reversing at a narrow place or on an uphill slope, the RPA sensors may not detect railings, trees or slope surfaces, which is normal.**
- **When the reversing speed is fast, the radar sensor detection accuracy is reduced. It is recommended that the reversing speed should not exceed 10 km/h. When the RPA sends the continuous audible alarms, it indicates that the vehicle is extremely close to the detected obstacle, and reversing shall be stopped immediately to prevent an accident.**

## 5. Driving guide

### WARNING

- When a high-pressure cleaner is used, clean the RPA sensors in snatches gently, with the nozzle at least 30cm away from the sensor.
- If water drops are on the surface of the RPA sensors on the rear bumper, the sensitivity of the sensors will reduce. Wiping off them can restore the sensitivity of the sensors.
- The surface of some materials cannot reflect the signal from the RPA sensors, so that the RPA sensors cannot detect such materials or people wearing the clothing made of such materials.
- Noise sources outside the vehicle may interfere with the RPA sensors, preventing them from detecting any object.
- The radar sensor is a precision component, which shall not be disassembled and repaired without permission. Otherwise, GAC will not assume any responsibility for the damage arising therefrom.

### 5.5.2 Reverse image system \*

The reverse image system can cover the video at a wide angle up to 130° and display a wide-range image behind the vehicle on the AV system display to allow the driver to know various complex road conditions behind the vehicle and improve the safety of reversing.

#### Activating and deactivating reverse image system

With the vehicle power switch is in the “ON” gear, when the gearshift lever is in the “R” gear, the reverse image system will work automatically, and the AV system display will start to display the rear shooting screen, and the reversing dynamic trajectory will be displayed on the screen.

If the gearshift lever is move out of the “R” position, the reverse image system automatically will stop working and the AV system will exit from the reverse image.

### WARNING

The reverse image system cannot take the place of the driver's observation to the surrounding environment. The driver shall be concentrated and reverse safely according to the actual conditions.

### Dynamic trajectory

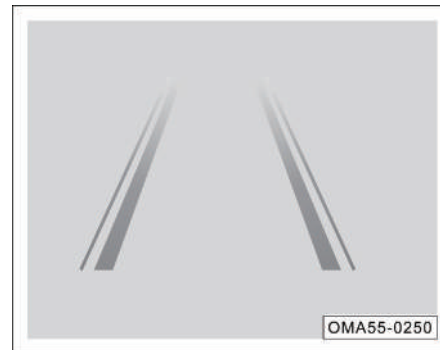

The display shows the trajectories of wheels and the vehicle body.



### CCD

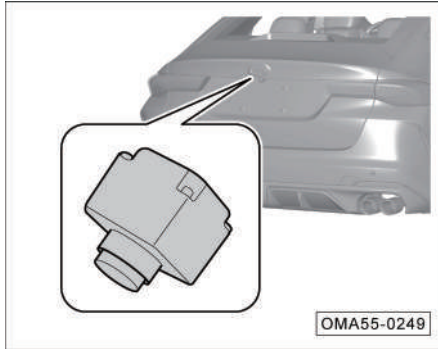

CCD is installed next to the license plate lamp.

### CAUTION

- Rear camera surfaces shall be kept clean at all times. Clean the surface of the CCD with a piece of soft damp cloth to avoid scratching.
- Do not use a high-pressure cleaner to clean the CCD for a long time, and if it to be used, please keep the nozzle at least 30 cm away from the CCD.
- Do not cover the CCD.

### WARNING

- **There is a blind spot in the rear camera. Because the camera may not be able to find young children or small pets, you must pay special attention to the surrounding young children or small pets during reversing.**
- **The CCD may not be able to recognize the vertical objects at high position, such as wall flange.**

## 5. Driving guide

### 5.5.3 Around View Monitor (AVM)\*

The AVM system collects the left, right, front, rear images of the vehicle and integrate them into a 360° bird's-eye view of the surrounding environment, which is displayed on the AVM system display to provide the driver with information on the surrounding environment of the vehicle and to reduce blind spots during driving. In addition, it can take the parameters such as steering wheel angle and vehicle dimensions into consideration to predict the vehicle's motion trajectory as well as superimpose the predicted track on the panoramic image to provide the driver with full information on the vehicle's direction of traveling, helping the driver to determine whether reversing is safe.

#### On and Off

1. It can be turned on or off through the gearshift lever. When the vehicle power switch is in the "ON" gear:
  - When the gearshift lever is moved to the "R" position, the AVM will be activated automatically.
  - When the gearshift lever is moved out of the "R" position and the driver do not carry out any relevant operation, the AVM will be deactivated automatically after 30s.



2. When the vehicle power switch is in the "ON" gear, click the menu key  in the system navigation bar on the left side of the desktop to enter the system detailed application menu interface, and click "AVM" soft switch to turn it on.
3. The system is turned on and off through the custom button on the steering wheel:

After the custom button on the center console display is set to AVM, when the vehicle power switch is in the "ON" gear, press the custom button  to turn on the AVM.

#### i NOTE

- When the system is activated, the AV system display will show the image around the vehicle and the reversing guidelines.
- If the vehicle speed is greater than 20 km/h during driving, the system will automatically be turned off.
- When the gearshift lever is not in "R" gear and the system activation time is longer than 30 s, the system will automatically be turned off (when the vehicle speed is zero).
- If not fully enabled, the AV system will not function normally.

### Interface description

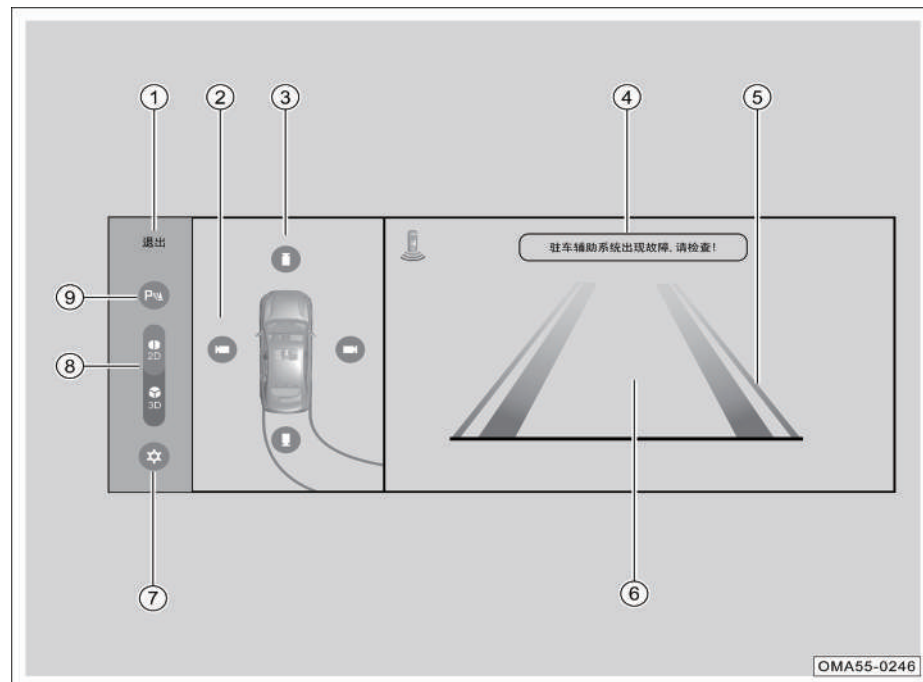

- ① Exit button
- ② Current perspective
- ③ Integrated view section
- ④ Text prompt pop-up window
- ⑤ Dynamic trajectory
- ⑥ Single view section
- ⑦ Setting button
- ⑧ 2D/3D view switching button
- ⑨ Radar audible alarm switch

## 5. Driving guide

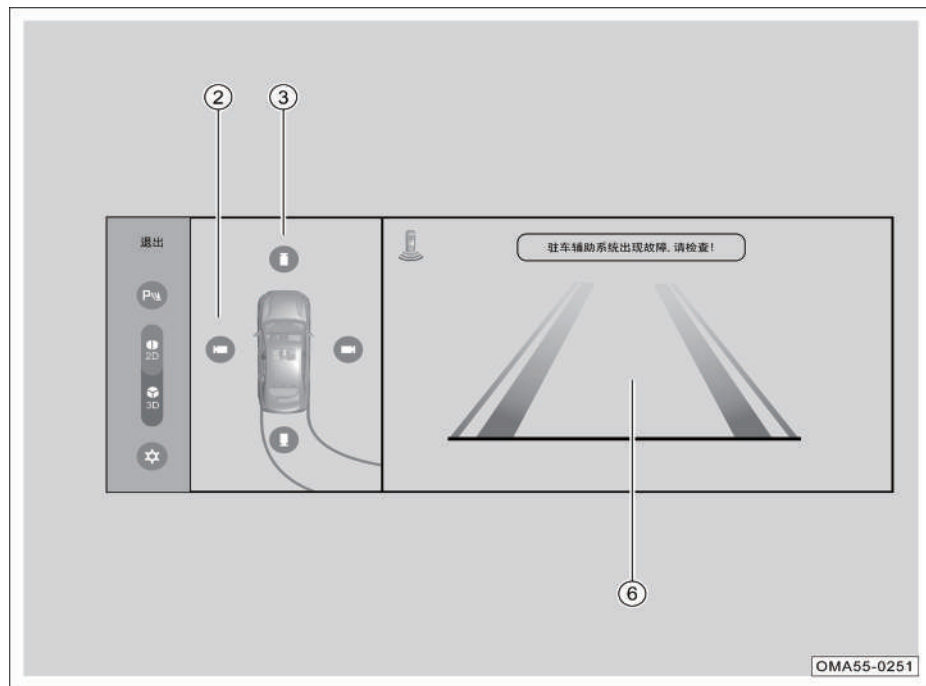

### 2D view interface:

- When the front/rear/left/right area in the integrated view section ③ is clicked, the single view section ⑥ displays the front/rear/left/right single view of the vehicle accordingly.
- Click the 3D button to switch to panoramic view + 3D simulation mode.

### **i** NOTE

- The description of the display interface is for reference only. If there is any difference, please refer to the actual vehicle.
- When the gearshift lever is in the "R" position, the system displays the rear view interface by default; When the gearshift lever is not in "R" gear, the system displays the front view interface by default.

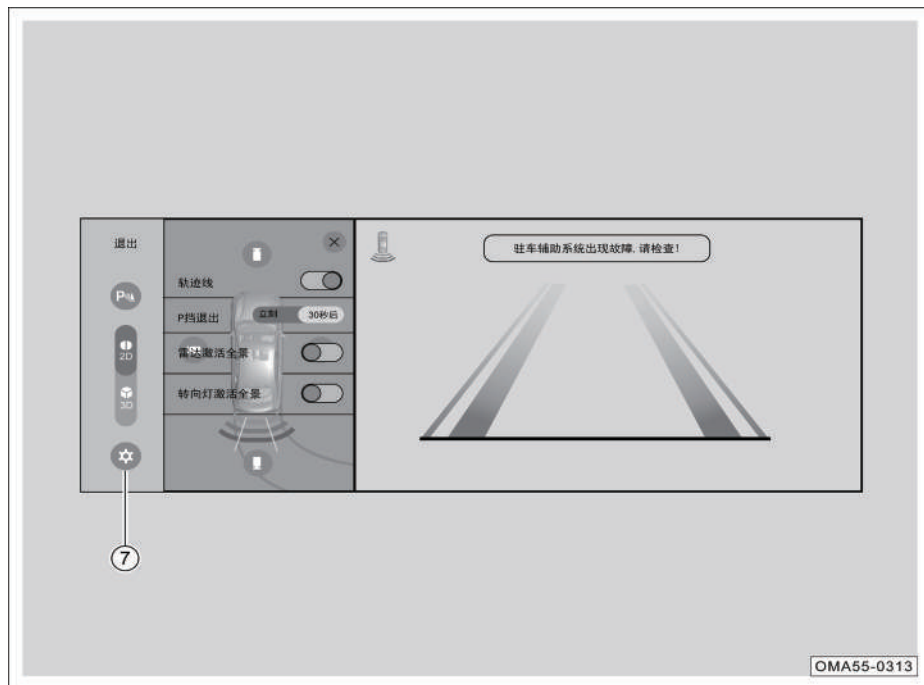

### AVM settings

Press the Setting button ⑦ to enter the AVM settings screen, where you can set the following options.

- Trajectory switch: When it is turned on, the display interface will show the dynamic trajectory that rotates with the steering wheel.
- Exit after shifting out of P gear: Set the exit time of the display interface when shifting out of the P gear.
- Sensor-activated AVM: When enabled, the AVM function can be activated when the RPA sensor is working.
- Turn-signal-lamp-activated AVM: The AVM function can be activated when the turn signal lamp or emergency lamp is on.

## 5. Driving guide

### Layout of cameras

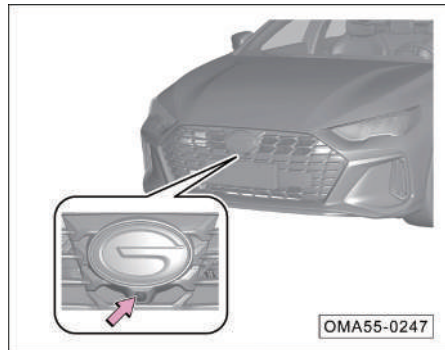

The front camera is installed under the front logo.

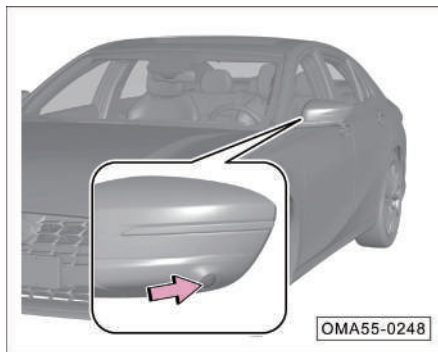

The left/right cameras are respectively installed at the bottom of the left/right exterior rearview mirror.

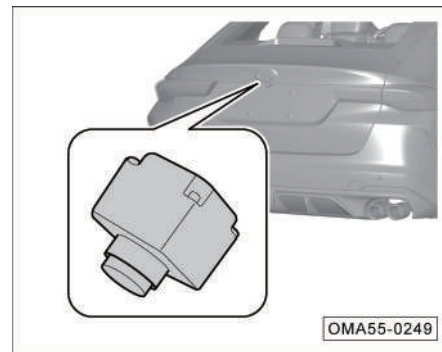

CCD is installed next to the license plate lamp.

### CAUTION

- Please keep the camera surface clean.
- Do not clean the camera with a high-pressure cleaner for a long time, and keep a distance of at least 30 cm from the camera during cleaning. Keep at least 30cm away from the camera.

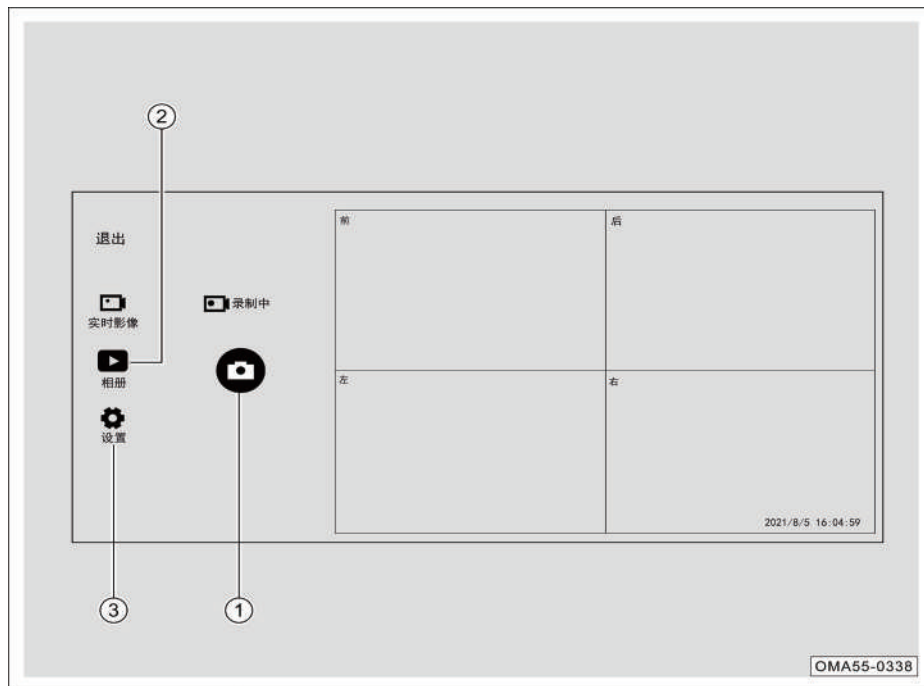

### DVR



The system is integrated with DVR, and after a TF card is inserted, the video recording, video & photo album, and setting functions of DVR can be operated. The DVR collects and processes the video taken in the front, rear, left and right sides of the vehicle, and displays and plays the video on the AV system display; the recorded videos are stored in the TF card of the AVM ECU.

Enter the main interface of DVR by clicking the "DVR" soft button in the AVNT application menu interface.



- After the TF card is inserted, the DVR enters the recording state by default, and the **REC** icon in the status bar of the AVNT indicates the current recording state.

## 5. Driving guide



### 1. Photographing

- Photographing: Click  soft button  to record the current around view and save it to TF card.

### 2. Album

- Click  soft button  to enter the album menu interface.
- The recorded videos and images can be displayed and played back separately through the album menu interface. You can also choose to lock or delete video or image files.

### 3. Setting

- Click  soft button  to enter the setting menu interface.
- You can set the video recording status and time through the settings menu. At the same time, you can also format the TF card by pressing the format soft button.

### CAUTION

- The video being recorded is not displayed in the menu bar.
- The original vehicle is not equipped with a DVR TF card. Users need to purchase it by themselves. Only after the TF card is installed can the DVR function be used normally. TF card should be of 16 G or 32 G and complies with Class 10 standard.
- Do not directly unplug the TF card during video recording. Unplug it only after normal power failure.

### Installation location of DVR TF card

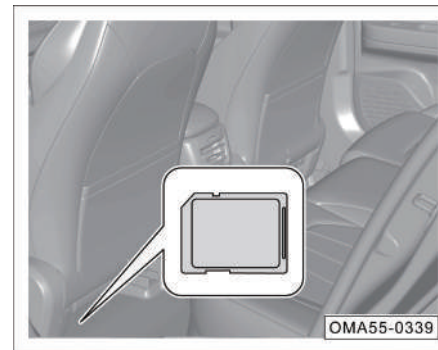

The AVM ECU and TF card are mounted under the driver's seat.

- It can be seen by lifting the velcro on the carpet.



### 5.6 Electric power steering (EPS)

Electric power steering system (EPS) is a power steering system that directly relies on the motor to provide auxiliary torque, and is mainly composed of a TAS, a motor, an ECU and a deceleration mechanism, etc.

The ECU controls the motor assist torque output in real time by detecting the driver's torque input, vehicle speed, engine speed and other vehicle status signals, providing the best steering assistance, ensuring the vehicle's low-speed steering agility and high-speed steering stability, and improving driving comfort and vehicle safety.

#### CAUTION

After wheel alignment of the vehicle, the position of the center point of the steering wheel will be affected, so it is necessary to re-calibrate the center point of the EPS TAS.

#### EPS indicator lamp

When the vehicle power switch is in the "ON" gear, the system performs self-test. The indicator lamp  will be turned off automatically after being turned on for several seconds, indicating that the EPS is normal.

If  indicator lamp does not go out or it lights up while the vehicle is running, this indicates that EPS has a malfunction, and the warning message "please check EPS" appears on the instrument cluster display. In this case, it is required to park the vehicle in a safe place, and shut down and restart the engine. If the indicator lamp does not go out or comes on again while driving, stop driving, and contact the GAC Motor authorized shop for inspection.

#### Turning force applied to the steering wheel

There are three modes for turning effort of the steering wheel: Light, Comfort and Sport, where the turning effort of the steering wheel will be small in Light mode, moderate in Comfort mode, and large in Sport mode. The system is in Light mode by default. There are two ways to select the turning effort of the steering wheel:

Method 1:

- Select it through the AV system "Driving mode → Current mode settings → Turning effort of the steering wheel".

Method 2:

- The turning effort of the steering wheel is set automatically by switching the driving mode (refer to chapter "4+X Driving Mode" => See page 181).

#### CAUTION

Please select the turning effort of the steering wheel when releasing the steering wheel in place.

## 5. Driving guide

---

### 5.7 Driving skills

#### 5.7.1 Traffic safety inspection

##### Routine inspection

- Check the tire for high/low pressure, cuts, bulges, damage or excessive wear.
- Check whether the wheel studs are missing or loose.
- Check whether the front & rear combination lamps and other lamps work properly; check the lighting direction of the front combination lamp.
- Check that the seat belt is not worn or damaged; check that the seat belt is fastened securely after fastening the seat belt.
- Check that the free travel of the pedal is sufficient.
- Check whether the levels of coolant, engine oil, brake fluid and windshield washer fluid are normal.
- Check the battery terminals for corrosion or looseness, and check the battery case for cracks or deformation caused by expansion.
- Check for leakage of fuel, engine oil, water or other fluids under the vehicle, and pay attention that water drip found after A/C operation is normal.

##### Inspections after starting/during driving

- Check whether the instrument cluster works properly; check whether any indicator lamp comes on or any alarm message is shown, etc.
- Check whether all controls (such as the lamplight combination, wiper combination and defrost switches) work properly.
- Check that the vehicle does not deviates to one side during braking on a road without safety risks.
- Check for other anomalies, such as part looseness, leakage and unusual noise.

#### 5.7.2 Driving in running-in period

In order to ensure the service life of the vehicle, the vehicle shall be run-in before being put into normal use. Please comply with the following rules in the running-in period:

- The mileage in the running-in period shall be 1500km.
- Choose roads in good condition and drive it at reduced load and limited speed.
- Do not start the engine with full throttle or drive with harsh acceleration.
- Avoid emergency braking in first 300 km.
- Strictly follow the operating procedures and make sure that the engine has reached normal operating temperature. Do not change the oil before regular maintenance.
- Carry out daily maintenance of the vehicle carefully; check and tighten the external bolts and nuts frequently; check the sound and temperature changes of the assemblies generated by operation and adjust them timely.

### Engine running-in

The mileage in the running-in period of a new engine shall be 1500km. Do not perform the following operations within the first 1000km of driving:

- Keep the vehicle speed no more than 3/4 of the maximum allowable speed.
- Do not drive the vehicle with full throttle.
- Avoid running the engine at high speed.
- Do not tow any trailer.

Within 1000km-1500km, it is allowed to increase the engine & vehicle speeds gradually to the maximum allowable range.

The internal frictional resistance of the engine at the beginning of running-in is much greater than that after running-in, and all the moving parts of the engine can have the best fitting after running-in.

After fully running in, both the service life and the fuel efficiency of the engine can be improved.

### Running-in of tire and brake lining

Within the first 500km of driving, drive the vehicle at a moderate speed to get the new tires run in fully.

Within the first 200km-300km of driving, the brake linings have not reach the optimal friction condition, so please drive at a low speed and avoid emergency braking as much as possible.

#### WARNING

- **New tires and brake linings without running-in do not have the best adhesion and friction. Therefore, drive the vehicle cautiously within the first 500km to get the tires fully run in to prevent accidents.**
- **Newly replaced brake lining shall be run in according to the above requirements as well.**
- **During driving, keep an appropriate distance from other vehicles to prevent emergency braking, as the new tires and brake linings have not been fully run in at this time and if an emergency braking is applied, a traffic accident is likely to occur.**

#### WARNING

- **If the brake is damp, frozen or the vehicle runs on a salted road, the braking effect will be reduced.**
- **During driving downhill, the brake is under large working load and liable to overheat. Before driving downhill, It is recommended to shift the vehicle into low gear to reduce the vehicle speed, make full use of the braking effect of the engine, and reduce the brake load.**
- **The brake shall be applied according to the road and traffic conditions. Do not step on the brake pedal unnecessarily to overheat the brake, resulting in too long braking distance and excessive brake wear.**
- **Do not coast the vehicle with the engine shut down. As the brake booster does not work, the braking distance will be greatly increased, which is liable to cause accidents.**

## 5. Driving guide

---

### 5.7.3 Driving essentials

#### Precautions under various road conditions:

- When the vehicle is driving on a road with crosswinds and gusts, please decelerate in advance and control the speed and steering wheel.
- Avoid driving on sharp-edged objects or other road obstacles, otherwise it may cause serious damage such as tire burst.
- Reduce the speed and drive at a low speed while driving on a bumpy or uneven road; otherwise the chassis may be scratched, which result in vehicle damage.
- When driving downhill, decelerate and downshift in advance (manual mode) to avoid emergency braking, which can overheat or wear the braking system too quickly.
- When driving on smooth roads, be careful when accelerating, upshifting/downshifting (manual mode) or braking. Rapid acceleration or emergency braking may lead to wheel slipping.
- When the vehicle is running on an icy or snowy road, drive at a low and constant speed; avoid sudden acceleration or emergency braking and install tire chains for the wheels when necessary.

#### Precautions while driving over a water-logged road section:

1. Before driving over a water-logged road section, check the depth of water, which shall not be higher than the lower edge of the vehicle body.
2. For driving in water, turn off the A/C before the vehicle starts to move, slow down the vehicle, and then gently step on and hold the accelerator pedal, in order to pass through the accumulated water section at a steady and slow speed.
3. Do not stop the vehicle, reverse or shut down the engine in water.
4. After successfully driving through the water-logged road section, gently depress the brake pedal for several times to evaporate the moisture on the brake discs so as to restore the braking performance as soon as possible.

#### **i** NOTE

The brake linings and brake discs are soaked in water while the vehicle is washed or driven over a road with deep water logging, and the braking effect will be greatly reduced; the braking distance will be longer than usual and the vehicle may be deviated to one side, and the parking brake cannot hold the vehicle still. In this case, it is recommended to drive the vehicle at a low speed and constantly depress the brake pedal slightly to remove residual moisture in the brake to recover the braking effect to the normal level. And then, normal driving can be resumed.

### Driving essentials in winter

1. Check if the coolant is in good condition and if it has good anti-freeze effect as follows:
  - Fill the cooling system with the coolant of the same type as the original one according to the ambient temperature.
  - Adding unsuitable coolant may cause damage to the engine.
2. Check the battery and cables as follows:
  - A low temperature in chilly days will reduce the capacity of battery, and therefore, fully charge the battery for start-up in winter.
3. Prevent the door lock from being frozen by ice and snow as follows:
  - Spray some de-icer spray or glycerin into the door lock hole to prevent the door lock from being frozen.
4. Use washer fluids containing antifreeze:
  - These products are available at GAC Motor authorized shop.
  - The mix ratio of water to antifreeze shall comply with the manufacturer's instructions.
5. Avoid accumulated ice and snow beneath the mudguard:
  - Accumulated ice and snow beneath the mudguard may result in difficult steering. Stop the vehicle regularly to check for accumulated ice or snow beneath the mudguard while driving the vehicle in severe cold winter.
6. It is recommended to bring some necessary emergency items according to the road conditions, such as:
  - Tire chains, a window scraper, a bag of sand or salt, a flashing light, a plough staff, connecting cables, etc., which are recommended to be placed in the vehicle.
7. In cold winter (especially in northern China), avoid starting the engine frequently and shutting down the engine immediately after a short-time start. If the engine is often in an alternating heat & cold cycle, the condensed water is likely to form in the engine, and when the condensed water adheres to the engine oil, it may give an illusion of water-in-oil emulsion, and after the engine is restarted and warmed up, this illusion will be shattered; in addition, please change the oil regularly as required in the *Warranty Manual*.

## 5. Driving guide

---

### 5.7.4 Efficient use of vehicle

- Before driving, make sure that the parking brake is completely released and the parking brake indicator lamp is off.
- Maintain sufficient tire pressure, as a too low tire pressure can cause premature tire wear and higher fuel consumption.
- Ensure that the wheel alignment is accurate. Otherwise it will cause premature tire wear, increased engine load and higher fuel consumption.
- Do not overload the vehicle, and unload unnecessary items from the vehicle, as excessive load will increase the engine load and the fuel consumption thereafter.
- Accelerate the vehicle slowly and smoothly to avoid rapid acceleration.
- Avoid roads with traffic jams as much as possible, as driving in traffic jam will increase the fuel consumption.
- Follow the instructions of traffic lights or maintain a safe distance with other vehicles while driving to avoid unnecessary stop or emergency braking, so as to save fuel and reduce wear on the brake system.

- When the vehicle is running, do not step on the brake pedal, as it will cause premature wear, overheating of the brake pad and wast of fuel.
- When driving, select good road surface. If driving on uneven roads, control the vehicle speed to avoid collision or scratches.
- If the chassis is stained with objects such as excessive dirt, clean them in time to reduce the vehicle's weight and prevent corrosion.
- Perform regular maintenance on the vehicle to maintain its optimal working condition, as dirty air cleaner, spark plugs, oil, and grease will reduce the engine performance and increase fuel consumption.
- When starting the engine at a low temperature, drive slowly for a few minutes, and ensure the engine is warmed up before acceleration.
- Do not open windows when driving at high speed.
- Properly use the A/C, etc.
- In case of parking for a long time, please shut down the engine to avoid wasting fuel due to long time idling of engine.

### 5.7.5 Fire prevention

In order to prevent vehicle fires, pay attention to the followings during use:

1. Never store flammables or explosives in the vehicle:
  - In hot summer days, the inside temperature of vehicles parked in the sun can be as high as 70°C or more. If flammables or explosives such as lighters, cleaning agents and perfumes are stored in the vehicle, fire and even explosion is likely to occur.
  - Items with risk of fire such as lithium batteries or power banks left in the vehicle by passengers are also likely to cause fire.
2. Make sure the cigarette butts are completely extinguished after smoking:
  - If the cigarette butts are not completely extinguished, fire may be caused.

3. It is recommended to regularly drive to the GAC Motor authorized shop for inspections:
  - Also subject all electric lines of the vehicle to regular inspections. Specifically speaking, check whether the connectors, insulation, and fixing positions of electrical components and harnesses are normal, and handle any problems found during inspection in a timely manner.
4. Never modify the electrical circuits or install additional electrical components:
  - Installation of additional electrical consumers (such as high-power audio device and xenon headlamps) will cause excessive load on the electrical line, causing overheating and even fire of harnesses.
  - Never use fuses that exceed the rated specifications of the electrical consumer or other metal wires to replace the fuses.
5. Precautions for driving:
  - During driving and parking, especially in summer, be sure to check if there are flammables such as hay, dry branches, leaves and wheat stalks under the vehicle, as they may be ignited by the components heated after long-time driving, such as engine exhaust pipe.
  - Do not park the vehicle in places involving serious rat infestation, such as garbage dumps, and do not place items that attract rats, such as snacks in the vehicle, because rats will bite through the harnesses and a fire will be caused therefrom.
6. Always place a lightweight fire extinguisher in the vehicle, and know its operation method:
  - In order to ensure the safety of the vehicle, place a fire extinguisher in the vehicle, and regularly check and replace it; at the same time, be familiar with the operation method of the fire extinguisher, so as to be prepared for handling any unexpected fire accident.

## 6. Operation and maintenance

### 6.1 Maintenance instructions

#### Safety precautions

To avoid potential hazards, please read this section before work and confirm that you have the necessary tools and techniques.

- Make sure that the vehicle is parked on a level ground, shut down the engine and apply the parking brake.
- When cleaning parts and components, use the commercially available de-greaser or parts cleaner, instead of gasoline.
- Keep lit cigarettes, sparks, and open flames away from batteries and all fuel system related components.
- When working on batteries or with compressed air, wear goggles and protective clothing.

#### WARNING

**Incorrect vehicle maintenance or driving the vehicle before the problem is solved may cause a traffic accident, resulting in serious injury or death.**

#### Potential hazards of the vehicle

- Carbon monoxide: Carbon monoxide in the exhaust gas emitted by the engine is a toxic gas. Be sure to start the engine in a well-ventilated place.
- Scald: The engine and exhaust system generate high temperature during operation, which is liable to cause scalding. Therefore, the relevant parts can be touched only after the engine and exhaust system cool down.

#### CAUTION

This section lists some of important safety precautions. We cannot list all the dangers you may encounter during maintenance work.

### 6.2 Internal maintenance

#### Cleaning and maintenance of instruments and plastic parts

Clean the surface of instruments and plastic parts with a clean soft cloth and clean water.

If it cannot be cleaned, it is required to use a special solvent-free plastic cleaning agent for cleaning.

#### CAUTION

Solvent-based cleaning agents can damage plastic parts.

#### WARNING

**It is forbidden to use cab sprays and solvent-based cleaning agents to clean the surface of the instrument panel and airbag assembly. Otherwise, it may loosen the surface and trigger the airbag, which may cause serious injury to occupants.**



### Cleaning and maintenance of carpet

Vacuum the dust on the carpet frequently.

Scrub the carpet regularly with detergent to keep it clean.

#### CAUTION

Please perform the cleaning in strict accordance with the operating instructions of cleaning agents.

#### WARNING

**It is forbidden to add water to the foam cleaner. The carpet shall be kept as dry as possible.**

### Cleaning and maintenance of leather\*

- Vacuum the dust.
- Clean the leather with a clean soft cloth and clean water.
- Wipe the leather dry with another dry soft cloth.
- If the cleaning methods described above are not enough to clean stains, please combine these methods with special leather cleaning soap or detergent.

#### CAUTION

If a leather stain remover is used, wipe it dry with a soft dry cloth as soon as possible.

#### WARNING

**Never leave a soft cloth wet with leather stain remover on any part of the interiors for a long time. Avoid color fading or breakage of the resin or fiber of the interior fabrics.**

### Cleaning and maintenance of seat belts

- Pull the seat belt out slowly and keep it being extracted.
- Remove dirt from the seat belt by using a soft brush and neutral soapy water.
- After seat belts dry completely, retract the seat belts.

#### CAUTION

- The seat belt must be completely dry before it can be retracted. Otherwise, seat belt retractors may be damaged.
- Regularly check all the seat belts in the vehicle to ensure that the seat belts are clean and avoid hindering the normal operation of seat belts.

## 6. Operation and maintenance

---

### WARNING

- If the seat belt webbing, connectors, retractor mechanism or buckles are damaged, please go to the GAC Motor authorized shop for replacement as soon as possible.
- For the overhaul of an accident vehicle, seat belts must be replaced, no matter whether they are damaged or intact.
- Prevent foreign matters or liquid from entering the seat belt buckle, causing failure of the buckle and seat belt .
- Under any circumstances, it is forbidden to remove or modify seat belts without authorization.
- It is forbidden to use chemical cleaning agents to clean the seat belts, for fear of damaging the seat belt webbing and impairing the function of seat belt.

### Cleaning and replacement of filters

The vehicle is equipped with an air cleaner, an A/C filter, an oil filter, a fuel filter, etc. They aim to filter gases or fluids. If they are too dirty or clogged, the normal operation of corresponding systems will be affected. Therefore, it is recommended to regularly clean or replace the filters at the GAC Motor authorized shop according to the provisions of the *Warranty Manual*.

## 6.3 External maintenance

### Vehicle washing

Washing the vehicle frequently helps to protect its appearance.

Vehicle washing shall be performed in a cool place, rather than under direct sunlight. If the vehicle is left in the sun for a long time, wait till the vehicle body surface cools down before washing the vehicle.

When using an automatic vehicle washer, be sure to follow the instructions of the operator of the automatic vehicle washer.

### WARNING

The vehicle power switch must be set to “OFF” position before vehicle washing.

### CAUTION

The paint surface of the vehicle body is strong enough to withstand the washing of the automatic vehicle washer. However, it is important to pay attention to the effects on the paint surface. The structure of the automatic vehicle washer, the cleaning agent, the filtering state of the clean water, and the type of wax solvent that do not meet the requirements may cause damage to the paint surface.

### CAUTION

When the body has dirt such as asphalt, it needs to be cleaned with special detergent, and then washed with clean water to avoid damaging the surface finish of the body. Check the body for paint peeling and scratches while wiping the body. If any, drive to the GAC Motor authorized shop for touch-up.

When using a steam cleaner or a high-pressure cleaner to wash the vehicle, be sure to be very careful. Be sure to wash the vehicle in accordance with the operation instructions and requirements of the steam cleaner or high-pressure cleaner. Pay attention to the working pressure, temperature and spraying distance:

- When using a steam cleaner or a high-pressure cleaner to wash the vehicle, keep a sufficient water spray distance from the vehicle, and ensure the temperature does not exceed 60°C.

### Manual vehicle washing

- Rinse the vehicle with plenty of water to remove floating dust.
- Prepare a bucket of water and add a special cleaning agent for vehicle washing to it.
- Gently scrub the vehicle with a soft cloth, sponge or soft brush and rinse it several times from top to bottom.
- Rinse the parts such as wheels and door sills at last. Replace sponges or soft cloth while washing the vehicle.
- After scrubbing, rinse the vehicle thoroughly with plenty of water.
- After washing, carefully dry the paint surface of the vehicle using a soft towel or antelope skin.

- If the vehicle is equipped with a power sunroof, keep the water spray distance more than 80 cm when washing the vehicle. If the high-pressure cleaner is close to the vehicle, or if excessive pressure or temperature is used, the vehicle may be damaged.
- Do not wash a radar sensor or a parking assist camera with a high-pressure cleaner for a long time; when washing the radar sensor or parking assist cameras, keep the water spray distance more than 30 cm.

### WARNING

- **When washing the vehicle manually, pay attention to personal safety and beware of angular parts at the bottom of the vehicle to avoid being scratched.**
- **When washing the vehicle, pay special attention to the bottom of the vehicle and the inner side of wheelhouses. Do not hurt hands and arms with sharp parts.**
- **Do not flush water directly into the engine compartment when cleaning the vehicle. Otherwise, it will affect the service life of various parts and components in the engine compartment.**

## 6. Operation and maintenance

### Waxing

Regular waxing can protect the paint surface of the vehicle body and keep the vehicle body clean. In order to effectively protect the paint surface of the vehicle body, it is recommended to apply high-quality hard wax once a year to protect the paint surface against corrosion by external bad environments and to resist light mechanical scratch.

Be sure to wipe the appearance of the entire vehicle dry before waxing. Before waxing the vehicle, please select a high-quality wax protectant. High-quality wax protectant generally falls into the following two types:

- Body wax: Wax used to protect the paintwork from damage caused by adverse external environment such as sun exposure and air pollution. This type of wax is generally used for new vehicles.
- Polishing wax: Wax used to restore the paintwork that has been oxidized or has lost its luster. This type of wax is generally used to restore the gloss of paint surface.

### Cleaning and maintenance of external plastic parts

External plastic parts are generally washed with clean water, soft cloth and soft brushes. If they cannot be cleaned, please use the special solvent-free plastics cleaner approved by our company.

#### CAUTION

Do not use solvent-based cleaning agents when washing plastic parts. Otherwise, it is easy to damage the plastic parts.

### Washing of window glasses and rearview mirrors

Clean the window glasses and rearview mirrors with alcohol-based glass cleaner, and then wipe the glass surface dry with a clean, lint-free soft cloth or antelope skin.

After curing the surface of the vehicle body, remove the wax residue on the glasses with a special cleaning agent and cleaning cloth. Avoid scratching the wiper blade.

Remove snow from the windows and rearview mirrors using a small brush.

Remove accumulated ice using de-icer spray. Ice removal shovel can also be used, but special care should be taken to avoid damaging parts, and ice must be scraped in the same direction during the use.

#### CAUTION

- It is forbidden to scrape the surface back and forth.
- It is forbidden to remove ice and snow from the windshield and rearview mirror with warm or hot water. Otherwise, the windshields may burst.
- If there are residual objects such as rubber, grease and silicone on the glass, they must be removed with a special window cleaner or silicone cleaner.

### Cleaning and maintenance of wiper cover

Try to avoid parking the vehicle under a tree frequently/for a long time. In case of leaves or other debris on the surface of the wiper cover, please clean them in time.

### Cleaning of wiper blades

- Lift the wiper arm and carefully wipe off the dust and dirt from the wiper blade with a soft cloth.
- After cleaning, gently lower the wiper arm to the windshield.

#### CAUTION

- Care should be taken when lowering the wiper arm to prevent it from falling instantly and hitting the windshield.
- The surface of the wiper blade is coated with a layer of graphite to ensure smooth wiping without scratching noise. Solvent-based cleaning agents, hard sponges and sharp objects can damage the graphite layer. Damaged graphite layer will increase the wiping noise of the wiper, and the wiper shall be replaced in time.
- In winter or cold conditions, it's important to check whether the wiper blade is frozen with the windshield before using the wiper. If so, perform de-icing first. Otherwise, the wiper blade and wiper motor will be damaged.

### Maintenance of sealing strips

Frequent and proper protection of the rubber sealing strips of the doors, windows and other parts of the vehicle is intended to maintain their flexibility and prolong their service life. Such protection can also improve the tightness, make the door easy to open, reduce the impact sound of closing the door, and prevent freezing in winter.

When performing maintenance on sealing strips, remove dust and dirt from surfaces using a soft cloth. Apply special protective agent to rubber sealing strips regularly.

### Cleaning and maintenance of wheels

Regularly remove anti-skid salts on the wheels and debris on the brake linings, which can keep the wheels aesthetic, maintain the surface smooth and prolong the service life of wheels. It is recommended to perform the following operations regularly:

- Remove anti-skid salts on the wheels and debris on the brake linings using acid-free wheel cleaner every two weeks.
- Apply high-quality hard wax to the alloy wheels every three months.

#### CAUTION

- It is prohibited to maintain the wheel surface with vehicle polish or other abrasives.
- The wheels with damaged protective coating on surface must be repaired in time.
- Using a high-pressure cleaner may cause permanent visible or invisible damage to the wheels, resulting in serious injury or death.
- It is forbidden to use cluster head nozzles to spray the tires. Otherwise the tires will be damaged, causing traffic accidents.

## 6. Operation and maintenance

---

### 6.3.1 Maintenance of fighter green paintwork \*

The fighter green paint is made of matte car paint. Special care should be taken during its maintenance. If the vehicle needs special cleaning and daily cleaning, the rework has low efficiency, high cost and long cycle; The maintenance of matte vehicles is quite different from that of conventional colored vehicles, so customers need to pay attention to the maintenance methods.

#### Vehicle washing

If car washing is performed in a way that will damage the surface of the coating, repainting is needed. If there is dirt in the gap of coated surface, trimming is difficult.

- After washing the vehicle with water, gently wipe it with softer leather. If the dirt cannot be cleaned with water, clean it as follows:
- 1. After washing the vehicle with water, gently wipe it with softer leather. If the dirt cannot be cleaned with water, clean it as follows:
- Water marks, etc.: Clean with weak acid (citric acid).
- Bird droppings, insects, oil stains: Clean with a neutral cleaning agent.

- 2. Do not clean the vehicle with car washing machine or high-pressure washing machine.
- 3. Do not use a washing brush to wash the vehicle.

#### Other precautions:

- The parking lot should preferably be roofed or covered with thick cotton wool, etc.
- If you want to fix the brush marks, claw marks, footprints, etc., you need to repaint the whole.
- Please do not rub the painted surface hard.
- Please do not attach labels, tapes, etc.
- Please do not use wax or wrapping agent.
- Please do not use polishing paste.
- Please do not use solvent-based degreasing cleaners.

#### **i** NOTE

If you have any questions, please call the GAC Motor authorized shop.

### 6.4 Inspecting and adding fluids

#### 6.4.1 Fuel

As the amount of fuel decreases when the vehicle is running, the fuel gauge scale will gradually decrease. => See page 46

When the fuel level is too low, the yellow indicator lamp  flashes, and the instrument cluster will give an alarm message. At this time, fuel shall be added as soon as possible.

#### Adding fuel



- Press and hold the fuel tank cap opening button  to make the fuel tank cap pop up.

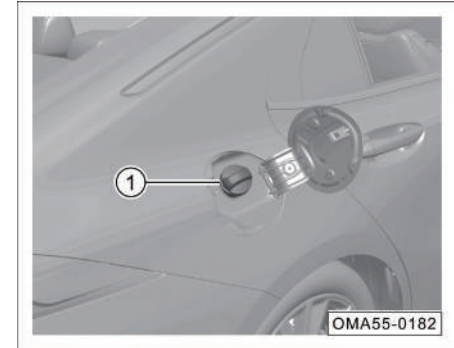

- Fully open the fuel tank cap, slowly unscrew the fuel filler cap ① in a counterclockwise direction, leave the fuel filler cap ① in place for a while when fully unscrewed, and take it out after the fuel tank has released the fuel vapor pressure inside it.

## 6. Operation and maintenance

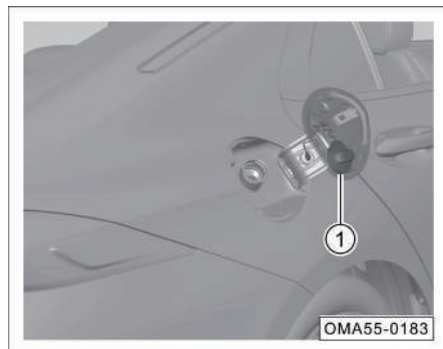

- Hang the fuel filler cap on the inner side of the fuel tank cap and start adding fuel.
- After adding the fuel, tighten the fuel filler cap ① clockwise until a “click” sound is heard, indicating that the fuel filler cap has been tightened.

### i NOTE

Fuel grade: 92# and above high-quality unleaded gasoline

### i NOTE

This model complies with China VI emission standards. The fuel supply system of China VI is designed with a closed fuel and gas recovery system. During refueling, the fuel gun switch may be triggered due to high ambient temperature or high fuel flow rate, and the fuel gun is switched off when the fuel tank is not filled fully. This is a normal phenomenon. At this time, the refueling speed shall be slowed down.

### 👁 CAUTION

Low-grade fuel or substandard fuel may damage the engine or make the engine fail to meet performance requirements.

### ⚠ WARNING

- **At any time, be sure to shut down the engine when refueling, and pay attention to open flames and fire.**
- **Please avoid contact of fuel with skin or clothing.**
- **Please refuel the vehicle according to the vehicle fuel grade. If fuel not complying with the regulations is added accidentally, do not start the engine. Please contact the GAC Motor authorized shop immediately for treatment.**



### Emergency unlocking

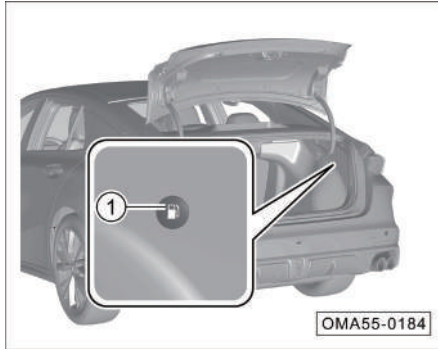

When the vehicle is out of power or the electric switch of fuel tank cap fails, the fuel tank cap can be opened in following steps:

- Open the trunk lid.
- Pull the emergency unlocking switch ① to unlock the fuel tank cap.

### 6.4.2 Engine oil

#### Function of engine oil

Engine oil has functions such as lubrication, sealing, cooling, anti-rusting and cleaning.

#### Specifications of engine oil

The engine has been filled with high-quality engine oil, which can be used in the year-round climate except for extreme cold weather before delivery.

When purchasing engine oil, please check whether the specifications indicated on the outer packaging of the engine oil are suitable for the engine of this vehicle.

#### i NOTE

- Oil grade: SN/ILSAC GF-5.
- Oil viscosity: SAE 0W-20.

#### ⚠ WARNING

**Always use the engine oil approved by our company. Otherwise, the ensuing engine damage will not be covered by the warranty.**

#### i NOTE

- Be sure to go to the GAC Motor authorized shop to change the engine oil according to the period specified in the *Warranty Manual*.
- If the vehicle is running under severe conditions, fuel with high sulfur content is used, engine idles for a long time (e.g., a taxi), the vehicle is driven in a high-dust area, the vehicle often tows a trailer, or the vehicle is used in an alpine area, the maintenance cycle shall be shortened and the maintenance times shall be increased.

## 6. Operation and maintenance

### Low oil pressure warning lamp

When driving, if the warning lamp  comes on, be sure to stop the vehicle in a safe place and shut down the engine. After the engine cools down, check the oil level.

If the engine oil level is normal, but the warning lamp is still on after the engine is started, do not continue to start the engine. In this case, contact the GAC Motor authorized shop timely for inspection.

#### WARNING

- Ignoring the warning lamps and related warning instructions may damage the engine.
- The low oil pressure warning lamp cannot indicate the oil level, and the oil level must be checked regularly.

### Inspecting the oil level

Be sure to check the oil level regularly. Park the vehicle on a level ground, apply the park brake, and shut down the engine. After the engine cools down, open the engine hood and check the oil level.

#### WARNING

- Be extremely careful while working in the engine compartment.
- The engine compartment is a high-risk area. Be sure to read and follow the relevant warning instructions carefully before opening the engine hood.

#### NOTE

While checking the oil level, ensure the engine is cold.

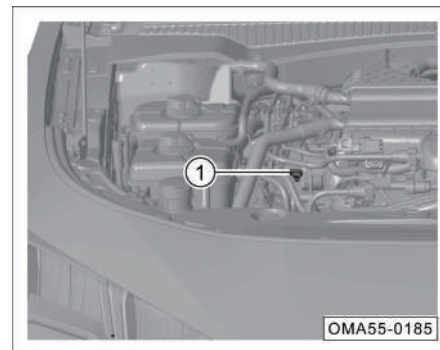

- Pull out the oil dipstick ①.

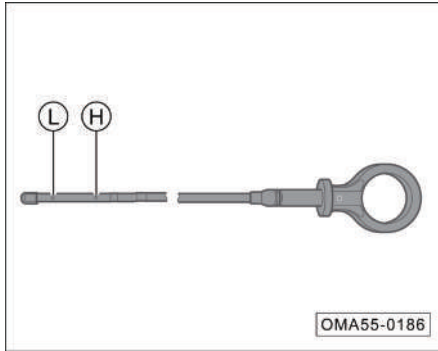

- Wipe off the oil stains on the dipstick using a clean cloth, and then insert the oil dipstick to the end.
- Pull out the dipstick again and read the measured oil level: The oil level shall be between the lower oil limit mark "L" and the upper oil limit mark "H".
- If there is too little engine oil, please add engine oil in time. Otherwise, poor lubrication will damage the engine.

### Adding engine oil

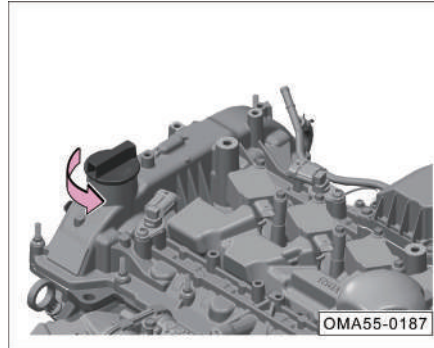

After checking the oil level, if required, add engine oil following the steps below:

- Unscrew the oil filler cap counterclockwise.
- Add small amounts of engine oil repeatedly, and check the oil level after each filling.
- When the oil level is close to the maximum scale mark "H", indicating the engine oil is sufficient, stop adding oil, refit the oil filler cap and tighten it clockwise.

### WARNING

- Be careful while adding the engine oil. Do not spill it. If the engine oil gets on skin, be sure to rinse the skin thoroughly.
- If too much oil is added, do not start the engine. In this case, please contact the GAC Motor authorized shop as soon as possible. Otherwise, the three-way catalytic converter may be damaged.
- After filling, be sure to tighten the oil filler cap to prevent the engine oil from splashing when the engine is being started, for fear of a fire.
- Since engine oil is toxic, it shall be stored in the original container and kept out of children's contact to avoid poisoning due to accidental ingestion.
- Do not add any lubricants to the engine oil. Otherwise, the engine will be damaged. Engine failure caused by adding lubricants is not covered by the warranty.

## 6. Operation and maintenance

### 6.4.3 Coolant

#### Function of coolant

Coolant has functions such as cooling, anti-freezing and anti-corrosion.

#### Specifications of coolant

When the vehicle leaves the factory, the cooling system has been filled with coolant, which can be used in the year-round climate except for extreme cold weather.

#### NOTE

- Coolant specifications: DF-6, -35 °C.
- Be sure to go to the GAC Motor authorized shop to change the coolant according to the period specified in the *Warranty Manual*.
- If the coolant discolors, the maintenance cycle shall be shortened and the coolant shall be changed at the GAC Motor authorized shop.

#### High engine coolant temperature indicator lamp

If the coolant temperature is too high, the indicator lamp  on the instrument cluster comes on in red, and an alarm message is given to prompt the driver; at this time, the vehicle must be stopped in a safe place and the engine shut down. After the engine cools down, check the coolant level.

If the coolant level is normal but the indicator lamp is still on after the engine is started, do not continue to start the engine. In this case, contact the GAC Motor authorized shop timely for overhaul.

#### Inspecting the coolant level

Be sure to check the coolant level regularly. Park the vehicle on a level ground, apply the parking brake, and shut down the engine. After the engine cools down, open the engine hood and then check the coolant level.



#### WARNING

- **Be extremely careful while working in the engine compartment.**
- **The engine compartment is a high-risk area. Be sure to read and follow the relevant warning instructions carefully before opening the engine hood.**
- **Do not open the hood if you see steam or coolant overflow from engine compartment, for fear of scald; The hood shall not be opened until there is no steam or coolant overflow and the engine has cooled down.**

### Engine coolant

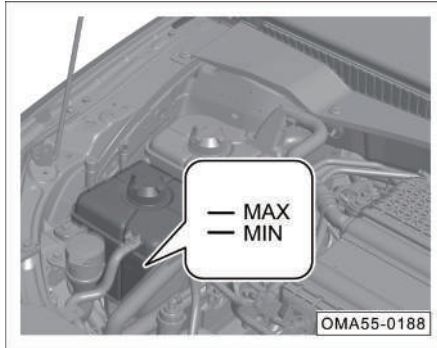

Check whether the coolant level in the expansion tank is between the maximum scale mark "MAX" and the minimum scale mark "MIN".

### Intercooler coolant

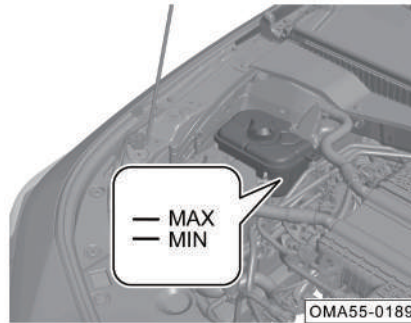

Check whether the coolant level in the intercooler coolant expansion tank is between the maximum scale mark "MAX" and the minimum scale mark "MIN".

### CAUTION

When the coolant level is lower than the lower limit mark "MIN", coolant must be added. Insufficient coolant will affect the cooling effect and cause damage to the engine or intercooler.

### Adding coolant



After checking the coolant level, if required, add coolant following the steps below:

- Wrap the expansion tank cap with a thick cloth and unscrew it counterclockwise.
- Add coolant to a level between the maximum scale mark "MAX" and the minimum scale mark "MIN".
- Tighten the expansion tank cap clockwise.

## 6. Operation and maintenance

### CAUTION

- When the engine is not cooled down, and the cooling system is under high pressure, do not open the expansion tank cap; otherwise you will be scalded by the gushing coolant.
- Coolant can only be added after the engine or the intercooler has cooled down. The coolant level after filling must not exceed the maximum scale mark "MAX". Otherwise, when the engine is started and the cooling system is under high pressure, coolant will overflow.
- Only fresh coolant is allowed to be added.

### WARNING

- **It is forbidden to mix coolant that is not approved by our company in the original coolant.**
- **In case of emergency, if other coolant are used or pure water is added, go to the GAC Motor authorized shop in time to clean the cooling system and add new coolant.**
- **If the too much coolant is consumed or it is consumed too fast, there may be a leak in the cooling system. In this case, please go to the GAC**
- **Coolant must be contained in the original container, and kept out of children's contact to avoid poisoning due to accidental ingestion.**

### 6.4.4 Windshield washer fluid and wiper blades

#### Adding windshield washer fluid

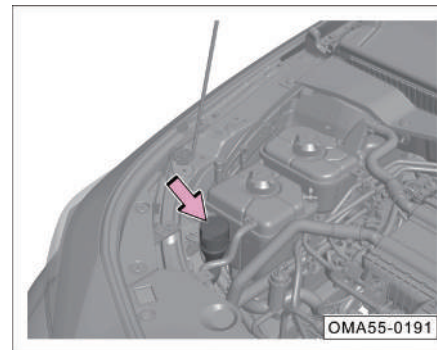

If the level of the washer fluid is too low, the washer fluid shall be added in time.

### CAUTION

Do not mix and use the windshield washer fluid with other cleaning liquids. Otherwise, the washer fluid will decompose and block the nozzle of the windshield washer.

### WARNING

- Be extremely careful while working in the engine compartment. Before operation, be sure to carefully read and follow the relevant warning instructions.
- Do not misuse coolant or any other additives as windshield washer fluid. Otherwise, oil stains will be left on the windshield during cleaning of the windshield, which will affect the visibility and easily cause accidents
- It is forbidden to use windshield washer fluid with ethanol content exceeding 10%. In high temperature environment, this type of windshield washer fluid will have corrosive effect on lamps and lead to cracking of lamps. It is recommended to use methanol washing solution.

### Replacing front windshield wiper blades

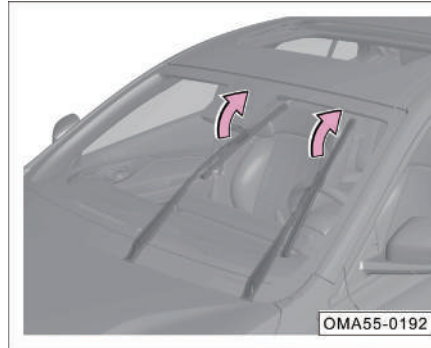

- Set the vehicle power switch to the "ON" gear and then to the "OFF" gear.
- Set the wiper combination switch to MIST within 10 s. The wiper arm will stop after running for half a circle.

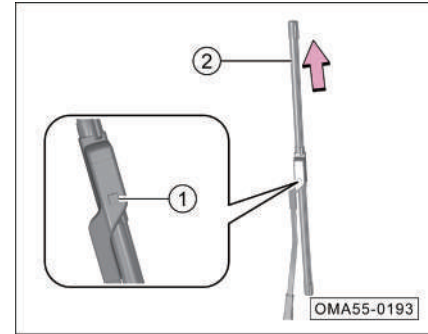

- Lift the wiper arm, press the locking button ①, and slide the wiper blade ② upward as arrowed to remove it.
- Install the new wiper blade into the wiper arm in reverse steps. It is installed in place when a "click" is heard.
- Gently put the wiper arm back on the windshield.
- When the vehicle power switch is set to "ON" position, the wiper arm will automatically return.

## 6. Operation and maintenance

If replacing wiper blades is required, it is recommended to go to the GAC Motor authorized shop for replacement.

### CAUTION

- When lifting the wiper arm, please grasp the wiper arm with hands, rather than grasp the soft wiper blade.
- New wiper blades with the same length and specifications as the previous ones must be used.
- Be careful while lowering the wiper arm to prevent it from falling and hitting the windshield instantly.
- The status of the wiper blades must be checked regularly, and the wiper blades must be replaced as specified. Damaged wiper blades must be replaced in time.
- Excessively worn or dirty wiper blades are very easy to scratch the windshield and will affect the field of vision when used, reducing driving safety.

### 6.4.5 Brake fluid

#### Function of brake fluid

Brake fluid is used to transmit power in the hydraulic brake system of the vehicle.

The brake fluid is water-absorbent, so it can continuously absorb moisture in the surrounding air during use. If the brake fluid stays in the system for too long and absorbs too much moisture, air resistance will generate in the system pipeline during braking, reducing the braking effect and impairing driving safety; it may even cause the complete failure of the brake system, resulting in accidents. Therefore, be sure to go to the GAC Motor authorized shop to check the brake fluid level or change the brake fluid according to the period specified in the *Warranty Manual*.

### NOTE

Brake fluid specifications: DOT4.

### WARNING

- **The use of waste brake fluid or brake fluid that does not apply to this vehicle will greatly reduce the braking effect and even lead to brake system failure! The company does not assume any responsibility (including quality guarantee) for vehicle failures and damage caused thereby.**
- **Brake fluid in use must meet the criteria and be fresh.**
- **The brake fluid packaging container is marked with its specifications. In all cases, brake fluid with correct specifications must be used.**

#### Brake system indicator lamp

When the vehicle is running, if the  indicator lamp comes on in red, and the instrument cluster displays the information "Please add brake fluid", be sure to immediately stop the vehicle at a safe place and check whether the brake fluid level is normal.



### Inspecting brake fluid level

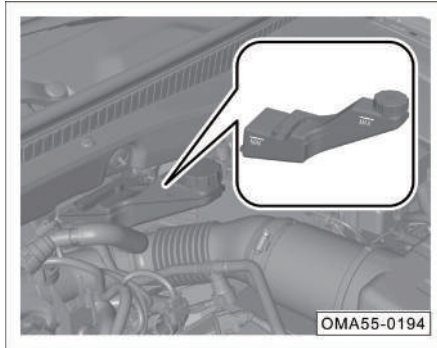

When the engine cools down, check whether the brake fluid level is between the maximum scale mark "MAX" and the minimum scale mark "MIN".

During vehicle use, the brake fluid level will slightly drop due to the worn brake linings and automatic adjustment.

If the brake fluid level drops significantly in a short period of time or drops below "MIN", it indicates that the brake system may leak.

### **i** NOTE

- **After check of the brake fluid level, if the fluid level is below "MIN", brake fluid must be added.**
- **If the brake system warning lamp does not go out or lights up again during driving after the brake fluid is added, there may be leakage in the brake system, resulting in too fast brake fluid level reduction or failure of the brake system. In this case, do not continue driving. Please contact GAC Motor authorized shop for maintenance in time.**

### Adding brake fluid

In order to ensure the normal operation of the brake system, the added brake fluid shall meet the specifications:

- Open the brake fluid reservoir cap counterclockwise.
- Add fresh brake fluid to the maximum scale mark "MAX" and stop adding.
- Tighten the brake fluid reservoir cap clockwise.

### **👁** CAUTION

- The brake fluid will corrode the paint surface of the vehicle body. Brake fluid splashed on the paint surface shall be wiped off in time.
- Using waste brake fluid or using brake fluid not applicable to the vehicle will remarkably reduce the braking effect due to incompatibility and even cause the brake system to fail.





### **⚠** WARNING

- **Brake fluid is toxic. It must be contained in the original sealed container, placed in a safe place, and kept out of children's contact to avoid poisoning due to accidental ingestion.**
- **Brake fluid must be stored in accordance with environmental protection laws.**

## 6. Operation and maintenance

### 6.4.6 Battery

#### Warning symbols and instructions for battery operation

	Goggles must be worn during operation!
	The battery electrolyte is highly corrosive. Protective gloves and goggles must be worn during operation!
	Open flames, sparks, uncovered lamps and smoking are prohibited in the workplace!
	Very explosive gas mixture is generated when the battery is being charged!
	Children must stay away from electrolytes and vehicle batteries!

In case of unfamiliarity with the operation process or no special tools, never carry out any operations on the electrical system of the vehicle, and contact the GAC Motor authorized shop.

#### Charging system warning lamp

The warning lamp is used to indicate alternator failure.

When the vehicle power switch is set to the "ON" gear and the engine is not started, the  warning lamp lights up, and the warning lamp shall go out after the engine is started.

When the vehicle is running, if the warning lamp comes on, it indicates that the alternator is no longer charging the battery. In this case, please go to the GAC Motor authorized shop for inspection in time.

#### Inspecting the battery

The battery must be checked according to the period specified in the *Warranty Manual*.

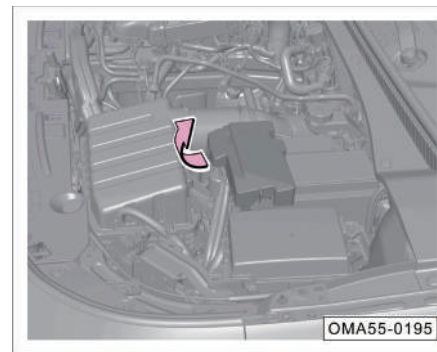

- Flip up the cover of the battery's positive terminal.
- Check the connection of the battery connector and the cable for corrosion or looseness; check the appearance of the battery for cracks, swelling, etc. If the phenomena above are found, please go to the GAC Motor authorized shop for inspection in time.
- If the vehicle has not been used for a long time, the condition of the battery should be checked frequently.

### NOTE

- If the battery power is insufficient or the battery is damaged, making it difficult to start the vehicle, please contact the GAC Motor authorized shop to charge or replace the battery in time.
- If the battery needs to be replaced, please go to the GAC Motor authorized shop for replacement; If the wrong type of battery is used, the vehicle may not be able to be used or the electrical system may fail due to incompatibility.

### Instructions for using the battery

After the engine is turned off, the battery will quickly discharge when an electrical consumer on the vehicle is being used:

1. Do not use an electrical consumer on the vehicle for a long time after the engine is turned off.
2. While leaving the vehicle, make sure that the doors are closed and all electrical consumers (e.g., lamps) are turned off.

### CAUTION

- When the engine cannot be started due to lack of battery power, try an emergency start => [See page 335](#). If the engine still cannot be started, please contact the GAC Motor authorized shop for overhaul.
- To avoid damage to the electrical system of the vehicle, never connect power generation equipment such as solar panels or vehicle battery chargers to a 12V power outlet.
- The battery contains toxic substances such as sulfuric acid and lead, so it must be properly disposed of and must not be treated as ordinary household waste.

## 6.5 A/C filter

### Inspecting and cleaning the A/C filter

Check or clean the A/C filter regularly according to the provisions in the *Warranty Manual*. If the vehicle is running in a dusty environment and the A/C filter is too dirty, it is recommended to replace the A/C filter earlier.

### NOTE

If you cannot disassemble and assemble the A/C filter yourself, please go to the GAC Motor authorized shop for professional help.

## 6. Operation and maintenance

### Removing and installing A/C filter

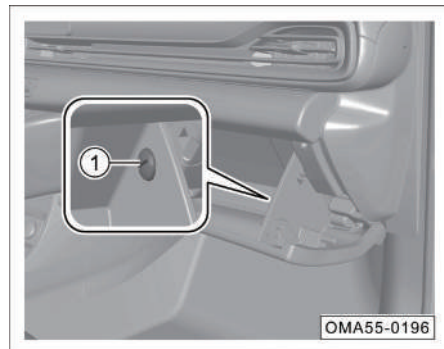

1. Open the glove box.
2. Screw out the fixing screw pin ① counterclockwise with a slotted screwdriver.

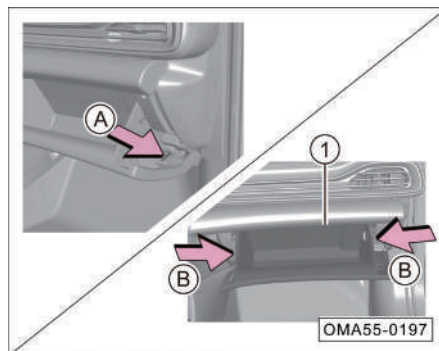

3. Disconnect the glove box from the damper in the direction of arrow A.
4. Press the glove box in the direction of arrow B and pull and disconnect glove box ① from the instrument panel assembly.
5. Remove the glove box.

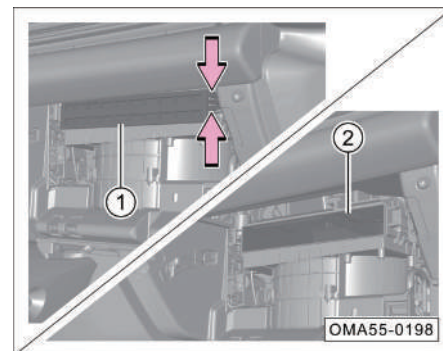

6. Press the filter element cover buckle as arrowed and take out the filter element cover ①.
7. Take out the A/C filter ② and clean it.
8. Refit the A/C filter as per the reverse steps.

### CAUTION

- Because the fiber layer on the back of the A/C filter cannot be blown off with an air gun, it cannot be cleaned and needs to be replaced in time after getting dirty.
- Because the A/C filter is made of special material, it shall not be washed with water. Otherwise, dust will accumulate and form clots, which will cause decreased air volume of A/C or even blockage.

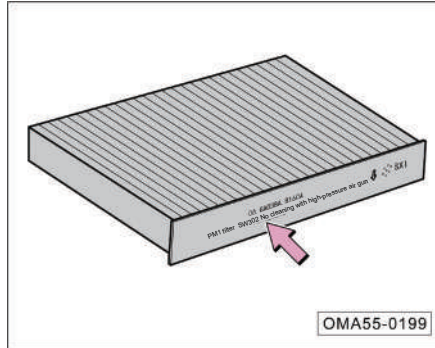

When installing the A/C filter, install it according to the A/C filter down mark.

## 6.6 Replacing bulbs

### Instructions for replacing bulbs

When replacing bulbs, be careful not to touch the bulb glass with fingers. Otherwise, the heat of the bulb will evaporate the grease on the bulb from fingerprints and condense it on the bulb glass, reducing the illuminance of the lamp.

The working state of the lamp must be checked after the bulb is replaced. Please go to the GAC Motor authorized shop in time to check the beam state of the lamp.

### NOTE

- The vehicle lamps include halogen lamps or LED. If the LED bulb is damaged, please go to the GAC Motor authorized shop to replace it in time.
- The removing and installing methods of the left and right bulbs are basically the same. Here only the removing and installing methods of halogen bulbs on one side are described.

## 6. Operation and maintenance

### CAUTION

The damaged bulb must be replaced with a new bulb of the same specification. The bulb specification of this vehicle => See [page 313](#).

### WARNING

**If you are unfamiliar with the operation process, safe operation specifications and tool operation methods, do not replace bulbs yourself.**

- Turn off all lights before replacing the bulb, and allow the bulb to cool before replacing it.
- Pay attention to the sharp parts on the combination lamp housing in the engine compartment during operation, and be careful not to scratch hands while replacing bulbs.

### Preparation for replacing bulbs

If it is found that any bulb is damaged, replace the bulb as soon as possible. Before replacement, make the following preparations:

1. Turn off all lamps.
2. Set the vehicle power switch to "OFF" gear.
3. Check whether the related fuse is blown. When the fuse is in good conditions, perform bulb inspection and replacement.

### Removing the rear combination lamp A

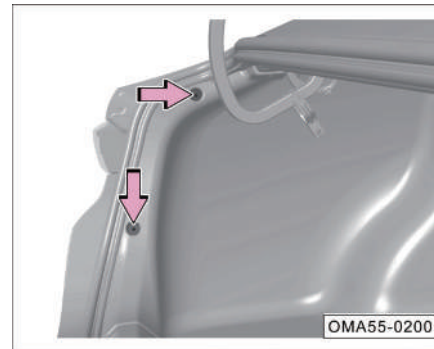

1. Switch off the vehicle power supply.
2. Open the trunk lid.
3. Pry off the fixing pegs and lift off the side trim of the trunk.

## 6. Operation and maintenance

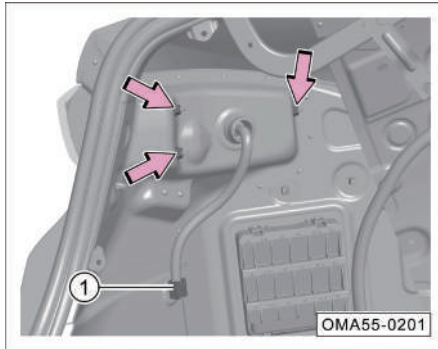

4. Disconnect plug ① of rear combination lamp A.
5. Screw out the fixing nut as arrowed of rear combination lamp A.

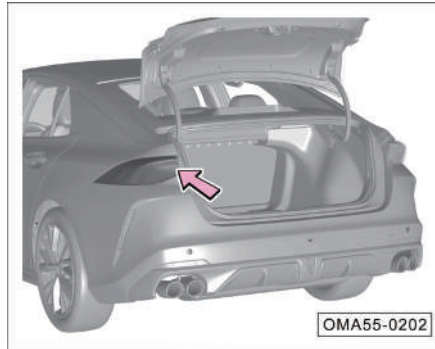

6. Remove rear combination lamp A backwards.
7. Install the rear combination lamp in the reverse order after removing it.

### Replacing rear turn signal lamp bulb

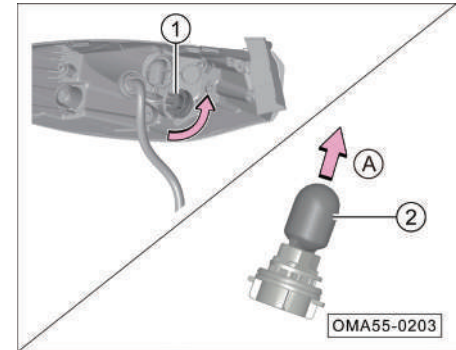

1. Remove rear combination lamp A. => See [page 297](#)
2. Screw out the rear turn signal lamp bulb and lamp holder ① counterclockwise.
3. Take out the rear turn signal lamp bulb ② in the direction of arrow A.
4. Replace the original bulb with a new rear turn signal lamp bulb in the reverse order.

## 6. Operation and maintenance

### Replacing the reversing lamp bulb

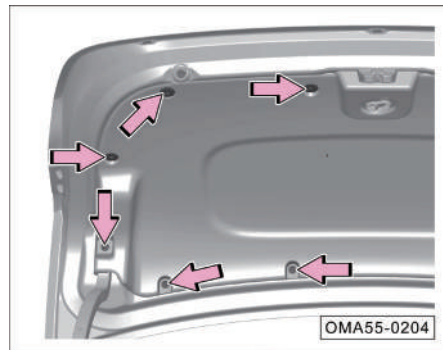

1. Switch off the vehicle power supply.
2. Open the trunk lid.
3. Pry off the fixing plastic nail as arrowed, and lift off the trunk lid trim.

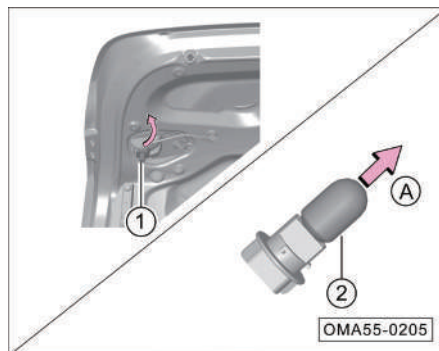

1. Rotate counterclockwise and take out the reversing lamp holder and bulb ①.
2. Pull out the reversing lamp bulb ② from the reversing lamp holder.
3. Replace the original bulb with a new reverse lamp bulb in the reverse order.

### 6.7 Wheels

#### WARNING

Within the first 500 km, the road adhesion of new tires is unlikely to reach the best condition. Therefore, the vehicle shall be drove carefully at a moderate speed to prevent accidents.

- Inadequate road adhesion of tires not subject to running-in period or excessively worn can directly affect the braking effect.
- If abnormal vibration or deviation of the vehicle is found during driving, stop the vehicle immediately and check whether the tire is damaged.
- In case of uneven and excessive tire wear, please go to the GAC Motor authorized shop for inspection and repair in time.



### WARNING

If tires burst or leak when the vehicle is running, it is very easy to cause serious traffic accidents.

- Do not use damaged tires and wheels, or use tires that have been worn to the tread wear indicator. Otherwise, it is very easy to cause an accident, because such tires may burst during driving, causing traffic accidents and injury. Such tires and wheels shall be replaced in time.
- Tire pressure must be within normal limits, otherwise, accidents may occur. If the tire pressure is insufficient, the continuous high-speed running of the vehicle will cause the tire to deflect, and the tire is extremely easy to overheat, which may cause tread separation or tire burst.
- Do not expose tires to chemicals, oil, grease, fuel and brake fluid.

### WARNING

- Never use old wheels and tires of unknown origin under any circumstances. Although such wheels and tires do not have visible damage, they may have been damaged. During driving, they may cause the vehicle to lose control and lead to traffic accidents.
- It is not recommended to use recycled tires. For such tires, the carcass may degrade as the service time passes, and the durability may also be restrained, impairing the driving safety.

### Precautions for wheel failure

- When driving over curbs or similar obstacles, keep a slow speed in the vertical direction of the obstacles as much as possible.
- Keep tires off grease, oil or fuel.
- Regularly check the tire damage status (e.g. cuts, wear, shedding, deformation or bulge).
- Regularly remove debris embedded in the grooves of the tire pattern.

### Instructions for storing tires

- Before removing the tire, make a mark on the tire to indicate the rotation direction of the tire. Refit the tire according to the mark to ensure the rotation direction and the dynamic balance of the wheel are unchanged.
- Store the removed wheels or tires in a cool, dry place, and preferably in a dark place.
- The tire mounted on the rim must not be stored upright.

## 6. Operation and maintenance

---

### New tires and wheels

- Select the new tire and wheel carefully, and make sure that the dimensions, load range, rated speed and structure type of new tire are the same as those of original one.
- Replace at least two tires on the same axle at the same time, rather than only one tire individually.
- Do not use tires of different dimensions or types, and do not mix summer tires, all-season tires and winter tires in use.
- After each wheel installation, check whether the wheel bolts are tightened to specified torque (125±10 N•m).

### Non-full-size spare tires

Spare tires and standard tires are different in aspects such as structure, pattern, speed rating and load index, and cannot be exchanged.

After emergency use of spare tire, please go to the GAC motor authorized shop or wheel repair shop for full-size tire replacement in time and safely to avoid driving safety hazards caused by long-term use of spare tire.

#### **WARNING**

- **Spare tires can only be used temporarily for emergency, and the maximum driving speed shall not exceed 80 km/h.**
- **The storage and service life of spare tires is 6 years. It is prohibited to use them beyond the time limit.**

### Summer tires

Summer is a rainy season. The tire tread depth directly affects the driving safety in rainy days. In summer, when the tire tread depth is less than 3 mm, there is a high risk of water slippage.

### Winter tires

Winter tires still have good grip performance when roads are covered with snow and ice. The specially designed rubber tread makes the tires less affected by low temperature environment and excellent braking ability, ensuring driving safety.

- Use winter tires on all the four wheels.
- It is recommended to use winter tires when driving in icy or snowy days in winter or when the temperature is below 7°C.
- Use only radial winter tires of same dimensions, load range and rated speed as original ones on this vehicle.

## 6. Operation and maintenance

- Please note that the tread of winter tires shall have patterns deep enough (tread depth not less than 4 mm; otherwise, the applicability in winter will be limited).
- After installation of tires, check the tire inflation pressure.

### WARNING

- **Winter and summer tires are designed according to the typical lane driving conditions under the corresponding seasonal conditions. It is recommended to use winter tires in winter. At low temperatures, the adaptability of summer tires is significantly poorer, thereby losing road adhesion and braking ability.**
- **If summer tires are used in severe cold conditions, cracks may appear on the tires, thereby completely damaging the tires, and causing excessive tire noise and loss of balance.**

### WARNING

- **After using winter tires, there may be decreased driving traction on dry roads, increased road noise and shortened tread life. Please pay attention to the performance change of the vehicle in terms of maneuvering and braking after the winter tires are used.**
- **Please note that the maximum speed for winter tires is relatively low. Do not exceed the allowable maximum speed for the tires.**
- **Please note that please replace the winter tires with summer tires in time in order to ensure driving safety and performance when driving in the environment at the atmospheric temperature rising above 7°C**
- **When driving with winter tires, if a spare tire is installed, unstable steering characteristics may occur due to different tires, weakening driving stability. In this case, driving styles need to be adjusted and driving shall be performed carefully.**

### Inspecting tire pressure

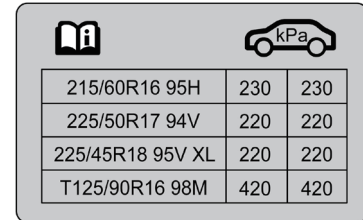

215/60R16 95H	230	230
225/50R17 94V	220	220
225/45R18 95V XL	220	220
T125/90R16 98M	420	420

OMA55-0206

The standard tire pressure data label of the original tire of this vehicle is attached to the B pillar on the driver's side.

- Check the tire pressure applicable to the vehicle from the data label (the listed pressure applies to both summer and winter tires).
- Unscrew the valve cap (if the valve cap is missing, a new one shall be provided in time).
- A high-quality tire pressure gauge is required to check the tire pressure. It is impossible to determine whether the tire pressure is appropriate only by visual inspection.
- Attach the tire pressure gauge to the valve.

## 6. Operation and maintenance

- For inspection of tire pressure, the tire must be in a cold state. When the temperature increases, the tire pressure can be slightly higher than the specified value, and it is not necessary to reduce the tire pressure.
- Balance the weight of occupants and luggage, avoid slopes and adjust tire pressure according to vehicle load.
- Check the tire pressure of the spare wheel or emergency spare wheel at the same time.
- Install and tighten the valve cap.

### **i** NOTE

- The current wheel tire pressure can be viewed through the instrument cluster display information.
- Be sure to reinstall the valve cap on the valve core. The valve cap can prevent dust and moisture from entering the tire.

### **⚠** WARNING

- **Abnormal tire pressure may cause tire burst, resulting in a traffic accident, injury or even death.**
- **Check the tire pressure at least once a month or before long-distance driving. The tire pressure must meet the specified requirements to prevent accidents.**
- **Insufficient tire pressure will exacerbate tire deflection, and tires are extremely prone to overheating, which may lead to tread separation and tire burst.**
- **Abnormal tire pressure, too low or too high, will cause early wear of tires and reduce the maneuvering stability of the vehicle.**

### Service life of tires

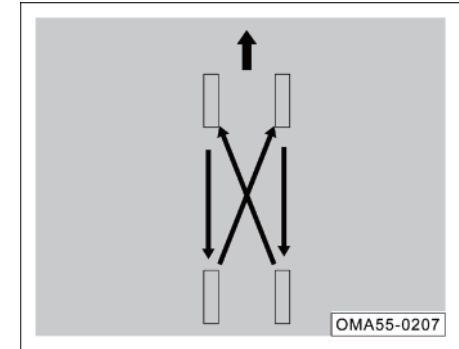

Service life of tires depends on tire pressure, driving style and tire assembly conditions.

If the front tires are worn more serious than the rear tires, it is recommended to perform tire rotation for the front and rear wheels as shown, so as to make the service life of all tires about the same.

### Tread wear indicator

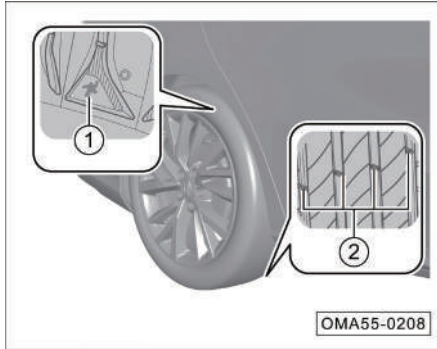

The mark ① is used to indicate the wear condition of the tire outer circle pattern. If the tire outer circle pattern wears to the condition as shown, the tire can no longer be used safely and must be replaced immediately.

The height of tread wear indicator ② is 1.6 mm. If the tread pattern is worn to the indicator surface, this tire can no longer be used safely and must be replaced immediately.

### Wheel balance

The wheels of the new vehicle are already balanced. Due to various reasons, the wheels may go unbalanced during operation, which can be manifested by the vibration of the steering mechanism.

Because unbalanced wheels can cause excessive wear on the steering system, wheel suspension mechanism and tires, the wheels shall be rebalanced.

In addition, wheels must be rebalanced after installation of a new tire or tire repair for any wheel.

### Wheel misalignment

Wheel misalignment will cause uneven and excessive wear of the tires, affecting driving safety. If uneven and excessive wear of the tires is found, please go to the GAC Motor authorized shop to check the wheel alignment as soon as possible.

## 6.8 Tire chain

In winter, driving in harsh environments such as snowy or icy roads can increase the degree of tire wear or cause other failures. To reduce failures in winter, the following opinions must be followed:

- When driving in deep snow, it is necessary to install tire chains on the tires. In this case, be sure to choose an equivalent product whose size and type meet the specifications of the tires on the vehicle. Failure to observe this point will adversely affect the performance and safety of the vehicle. Moreover, operations such as full-load driving, speeding, emergency acceleration, emergency braking, and emergency turning are potentially dangerous.
- During deceleration, make full use of the engine braking function. Emergency braking on snowy or icy roads will cause the vehicle to drift and slip. Keep a proper safe distance from the lead vehicle, and step on the brake pedal slightly. Note that the tire chain installed on the tire can provide a certain friction force, but it cannot prevent sideslip.

## 6. Operation and maintenance

---

### NOTE

Various countries and regions have different regulations on tire chains. Before assembling tire chains, please refer to the laws and regulations of the corresponding country and region. Do not install tire chains without understanding the laws and regulations of the corresponding country and region that may restrict the use of tire chains.

### CAUTION

- Install tire chains on all tires to ensure balanced driving in all weather. It shall be borne in mind that after installation of tire chains, the vehicle may be underpower. Even if the road surface is in good condition, drive carefully. While driving, neither exceed the specified speed limit of tire chains nor exceed 50 km/h, whichever is lower.

### CAUTION

- If tire chains are installed on the tires, the size and type of tire chains shall be consistent with those of the standard tires of the vehicle. Otherwise, the driving safety and maneuvering of the vehicle will be adversely affected.
- The tire chains must be installed on the front tires in pairs. Do not install them on the rear tires.
- Do not install the tire chain on the emergency spare tire. If a spare tire is installed at the position of the front wheel where a tire chain is required, be sure to exchange the position of the spare tire with one rear tire.
- Do not use tire chains on dry ground. After driving to snow-free roads, remove tire chains.
- After installing the tire chains as closely as possible to the front tires, drive 0.5~1.0 km, and then tighten the tire chains again.

### 7.1 Identifications

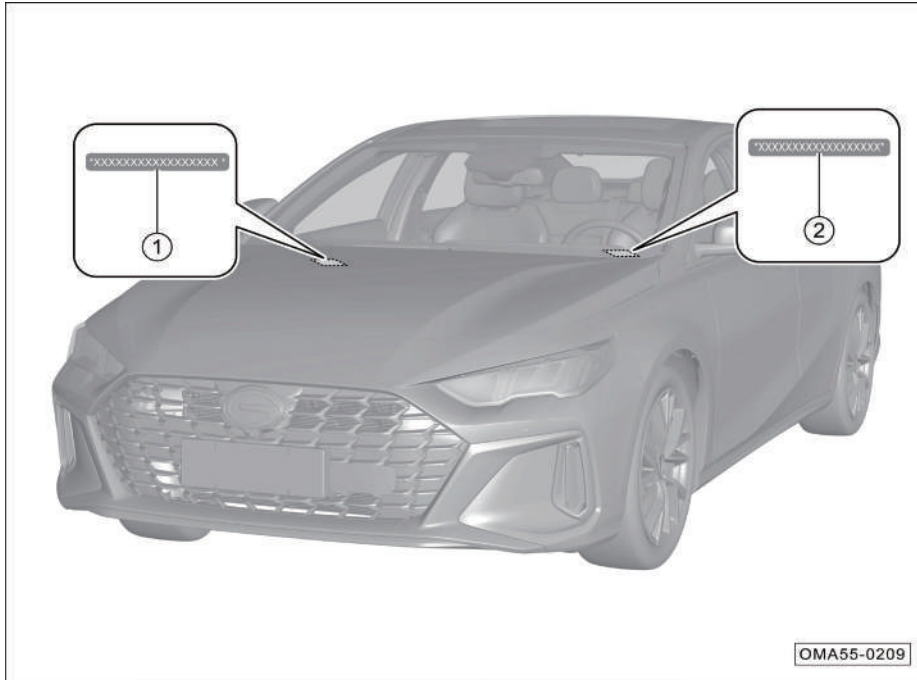

The locations of the vehicle identification number (VIN) is shown in the figure:

- ① VIN: Located on the engine compartment partition.
- ② VIN: Located on the left side of the instrument panel.

#### **i** NOTE

The position indication and quantity of vehicle identification number (VIN) are not complete. Please refer to the actual vehicle.

## 7. Technical data

### OBD DLC

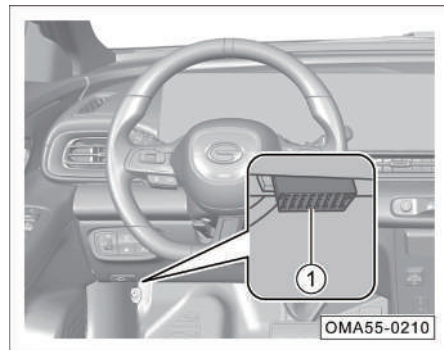

The OBD interface ① for reading the electronic VIN code is located at the lower left rear of the instrument panel, and data such as the electronic VIN code and vehicle status information can be read through the special diagnostic scan tool.

### Vehicle nameplate

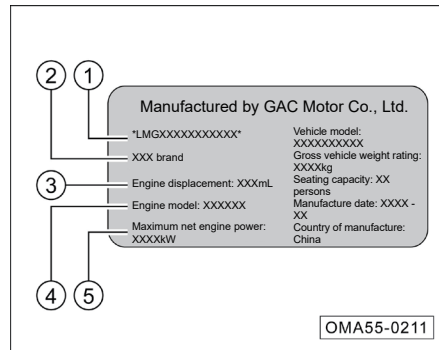

- ① VIN and vehicle model
- ② Brand, gross vehicle weight rating
- ③ Engine displacement, seating capacity
- ④ Engine model, date of manufacture
- ⑤ Maximum net power of engine, country of manufacture

### Engine model and factory number

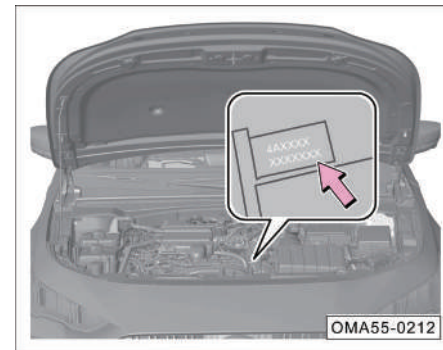

Engine model and serial number as arrowed is located on the engine block (above the starter mounting location).



### 7.2 Dimensions & parameters of vehicle

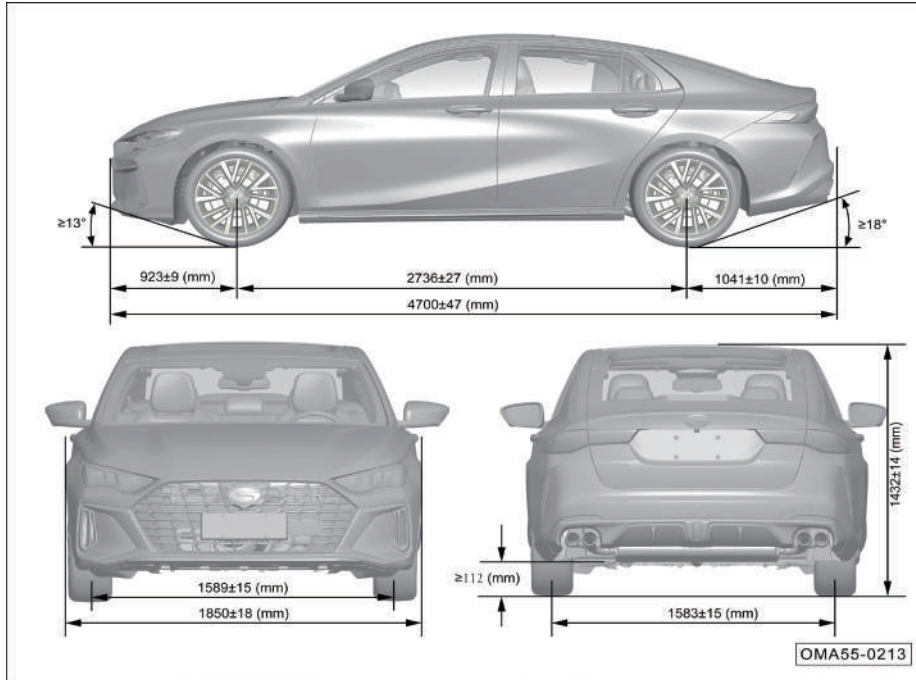

#### Dimensions

Item	Parameters	
	Numerical value	Unit
Overall length	$4700 \pm 47$	mm
Overall width	$1850 \pm 18$	mm
Overall height	$1432 \pm 14$	mm
Wheelbase	$2736 \pm 27$	mm
Wheel track	Front wheel	$1589 \pm 15$
	Rear wheel	$1583 \pm 15$
		mm
Front overhang	$923 \pm 9$	mm
Rear overhang	$1041 \pm 10$	mm
Minimum ground clearance (full load)	$\geq 112$	mm
Approach angle	$\geq 13$	°
Departure angle	$\geq 18$	°

Note: The exterior rearview mirrors (one on the left and one on the right) located near the junction between the lower end of the A-pillar and the front door and the shark fin antenna located above the rear of the roof are not included in the outer width.

## 7. Technical data

### 7.3 Vehicle mass, engine and fluid parameters

#### Mass

Model	Kerb mass of vehicle (kg)			Gross vehicle weight rating (kg)		
	Kerb mass (kg)	Front axle load	Rear axle load	Gross vehicle weight rating	Front axle load	Rear axle load
GAC7153BCW6A	1345±40	831±24	514±15	1790	957	833
	1400±42	855±25	545±16			
		845±25	555±16			

#### Comprehensive parameters

Item	Performance parameters	Unit
Seating capacity	5	Person
Minimum turning diameter	≤11.2	m
Maximum gradeability	≥40	%
Maximum speed	≥200	km/h
Fuel consumption in combined driving cycle (NEDC)	≤5.7	L/100km
CO <sub>2</sub> emissions (combined) (NEDC)	≤139.83	g/km

## 7. Technical data

### Parameters of engine

Model	4A15J2
Type	Gasoline engine, spark-ignition, in-line, 4-cylinder, 4-stroke, liquid-cooled, GDI, DOHC, exhaust gas turbocharging
Number of cylinders	4
Ignition order	1-3-4-2
Bore (mm)	74
Travel (mm)	87
Displacement (mL)	1497
Compression ratio	(11.5±0.3):1
Rated power/speed (kW (r/min))	130/5500
Maximum net power/speed (kW (r/min))	125/5500
Maximum torque/speed (Nm/(r/min))	270/1400~4500
Maximum net torque/speed (N m/(r/min))	250/1400~4500
Stable idling speed (r/min)	700±50
Emission level	China VI

## 7. Technical data

### Specifications and capacity of fuel/oil/fluid

Item	Specification	Capacity	
Fuel	#92 high-quality unleaded gasoline (China VI) and superior grade <sup>1)</sup>	Total	47L
Engine coolant <sup>2)</sup>	DF-6, -35 °C	Total	7.2L
Intercooler coolant	DF-6, -35 °C	Total	3.0L
Engine oil:	Oil grade: SN/ILSAC GF-5 Oil viscosity: SAE 0W-20	Total <sup>3)</sup>	4.5L
		Replace <sup>4)</sup>	4.2L
WDCT fluid	Shell Spirax S5 DCT 12	Total	5L
Brake fluid	DOT4	Total	0.8L
Windshield washer fluid	Methanol-based Q35	Total	2.5L
A/C refrigerant	R134a	Total	550g
Compressor oil	PAG56	Total <sup>5)</sup>	5mL

Note: 1) Long-term use of fuels with sulfur content higher than the standard value may result in excessive emissions. Please pay attention and use fuels that comply with local standards for vehicles.

- 2) Including the coolant in the reservoir and the residual coolant in the engine.
- 3) Capacity of the overhauled engine assembly.
- 4) Including the replacement of oil filter.
- 5) Compressor oil filling volume for maintenance of A/C cooling system only

### 7.4 Parameters of transmission, chassis and lamps

#### Transmission parameters

Model	7WF25*	
Type	7WDCT	
Final ratio	4.050 (1st, 2nd, 4th, 5th, R gears)	2.531 (3rd, 6th, 7th gears)
1st gear	3.846	
2nd gear	2.308	
3rd gear	2.500	
4th gear	1.140	
5th gear	0.911	
6th gear	1.180	
7th gear	0.946	
Reverse gear	3.491	

#### Wheels

Specifications of rim	6J×16*, 7J×16*, 6.5J×17*, 7.5J×17*, 7J×18*, 8J×18*	
Tire specification	215/60R16*, 225/50R17*, 225/45R18*	
Tire pressure	Front wheel	Rear wheel
	220 kPa	220 kPa
	230 kPa	230 kPa
Installing spare tire Specifications*	T125/90R16	
Installing spare tire Air pressure	420 kPa	

Note: The standard air pressure data label of the original tire of this vehicle is pasted under the B-pillar on driver's side.

## 7. Technical data

### Suspension

Type	Front suspension	Rear suspension
	McPherson, independent	Multi-link, independent

### Steering gear

Type	Rack-and-pinion
Power steering type	Electric power steering

### Brake

Type	Vacuum booster, X-type hydraulic double circuit
Front wheel	Disc brake
Rear wheel	Disc brake
Parking brake	Electric park brake (EPB)

### Drive mode

Drive mode	FWD
------------	-----

### Dynamic balance of wheels

Designation		Residue dynamic unbalance
Front wheel	Inner side	$\leq 8g$
	Outer side	$\leq 8g$
Rear wheel	Inner side	$\leq 8g$
	Outer side	$\leq 8g$

### Free travel of brake pedal

Designation	Parameters
Travel	$\leq 106$ mm
Free travel	$\leq 6$ mm

### Technical parameters of brake linings

Designation	Parameters
Wear limit of front wheel brake lining (excluding the backplate of brake lining)	2 mm
Wear limit of rear wheel brake lining (excluding the backplate of brake lining)	2 mm

### Wheel alignment

Designation		Parameters
Front wheel	Individual toe-in	5'±3'
	Wheel camber	-20'±30'
	Kingpin caster angle	7°12'±45'
	Kingpin inclination angle	13°49'±45'
Rear wheel	Individual toe-in	5'±3'
	Wheel camber	-1°10'±30'

### Battery

Model		SLI 55520
Parameters	Rated voltage	12 V
	Capacity at 20 hr	55 Ah
	Low temperature start current (EN)	530CCA

### Fuse

Instrument panel PDU	=> See page 328
Engine compartment PDU	=> See page 331

### Lamps

Lamps		Model	Power
Front combination lamp	High beam	LED	/
	Low beam	LED	/
	Daytime running lamp*	LED	/
	Front position lamp	LED	/
	Front turn signal lamp*	LED	/
Side turn signal lamp on rearview mirror		LED	/
Rear fog lamp		LED	/
Rear combination lamp	Brake lamp	LED	/
	Rear position lamp	LED	/
	Rear turn signal lamp	WY21W	21W
	Reverse lamp	W16W	16W
License plate lamp		LED	/
High-mounted stop lamp		LED	/
Front dome lamp		LED	/
Rear dome lamp *		LED	/

## 7. Technical data

---

Lamps		Model	Power
Trunk lamp		LED	/
Ambient light *	Instrument panel left ambient light	LED	/
	Instrument panel right ambient light	LED	/
	Driver's and front passenger's footwell lamps	LED	/
	Console ambient light	LED	/
	Driver's door ambient light	LED	/
	Front passenger's door ambient light	LED	/
	Instrument panel middle ambient light	LED	/
Sun visor vanity mirror lamp*		C5W	5W

If the bulb needs to be replaced => [See page 295](#). Some bulbs are only applicable to certain models; please refer to the actual vehicle configuration!



### 8.1 Driver's tools, spare tire \*

#### Driver's tools

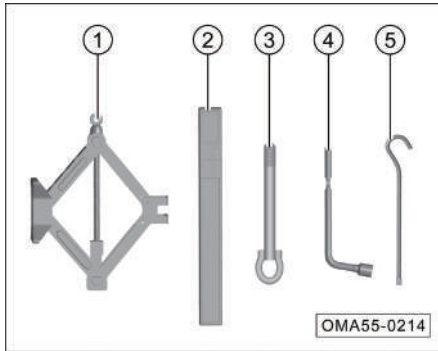

The following tools are provided with this vehicle. After use, they shall be cleaned in time and placed in the tool kit.

- ① Jack
- ② Warning triangle
- ③ Towing hook
- ④ Wheel bolt removal wrench
- ⑤ Special wrench for jack

#### Spare tire\*

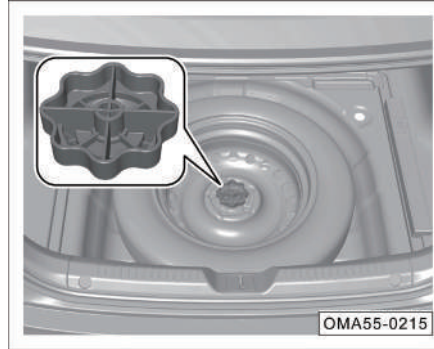

Remove the spare tire:

- Open the trunk lid and take out the trunk carpet.
- Take out the driver's tool kit.
- Screw out the spare tire center handwheel counterclockwise and take out the spare tire.
- The spare tire has been inflated Check its pressure regularly to ensure that it is at the specified maximum tire pressure, and perform multiple inspections every year.

#### **i** NOTE

- The spare tire has been inflated Check its pressure regularly to ensure that it is at the specified maximum tire pressure, and perform multiple inspections every year.
- When using the spare tire, the replaced full-size tire can be temporarily fixed at the place where the spare tire is mounted.

#### **⚠** WARNING

- **Use the spare tire in strict accordance with spare tire requirements to avoid danger.**
- **It is strictly prohibited to install and use more than 1 spare tire at the same time.**

## 8. Accident handling

### WARNING

- It is forbidden to use the spare tire that has been damaged or worn to the limit.
- The storage and service life of spare tires is 6 years. It is prohibited to use them beyond the time limit.
- After the spare tire is installed, check the tire pressure as soon as possible to make it within the specified range.
- The maximum speed of the spare tire shall not exceed 80 km/h and abrupt acceleration and emergency braking shall be avoided.

### 8.2 Use of warning triangle

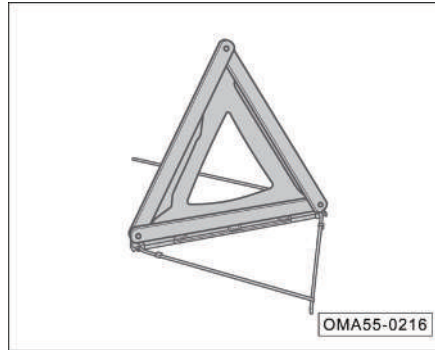

- Open the trunk lid, take the warning triangle out and unfold it for use.

### Placement distance

Ordinary highway		Expressway
Daytime	Night	
≥50m	≥80m	≥150m

### CAUTION

The data above is for reference only. Please place the warning triangle at the distance specified by traffic regulations.

### 8.3 Use of reflective vest

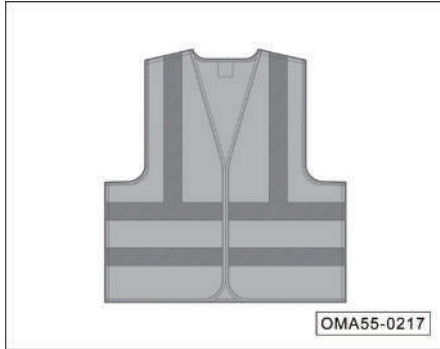

- If it is necessary to stop the vehicle due to an accident or other failures, take out the reflective vest from the glove box to put on it well before getting off the vehicle for checking and troubleshooting.

### **i** NOTE

- When handling vehicle accidents, no matter what kind of lighting conditions, it is necessary to wear a reflective vest as required to attract the attention of passers-by or other vehicle drivers.
- After using the reflective vest, please store the reflective vest properly in the glove box, and wash it according to the collar mark when necessary to maintain the reflective performance.

### 8.4 Inflator pump and tire sealer \*

Inflator pump and tire sealer are used to rectify the faults such as tire leakage or low tire pressure caused by a nail in a tire.

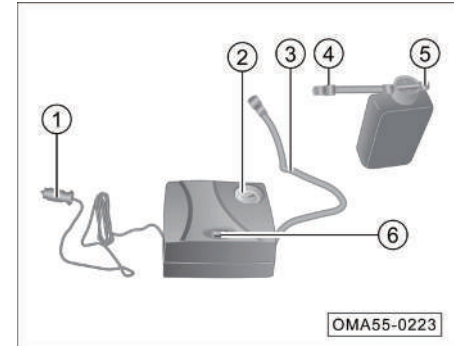

- ① Plug
- ② Air pressure gauge
- ③ Inflator tube
- ④ Sealer tube
- ⑤ Inflator tube fitting
- ⑥ Power switch

## 8. Accident handling

### Inflator pump

Operate as follows while inflating a tire:

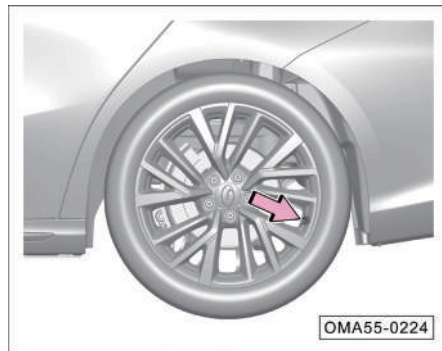

- Take out the automatic inflator pump from the trunk.
- Remove the tire valve cap.

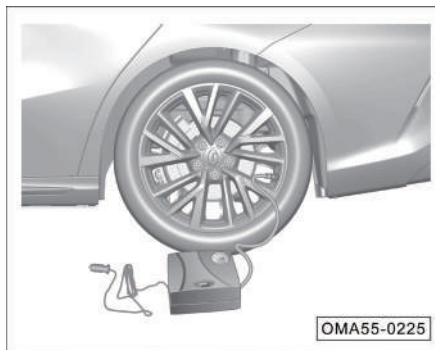

- Screw the fitting of the inflator pump into the tire valve, during which a slight air leak will be heard and it indicates that the air passage between the pump and tire has been established. In this case, go on screwing in the fitting.

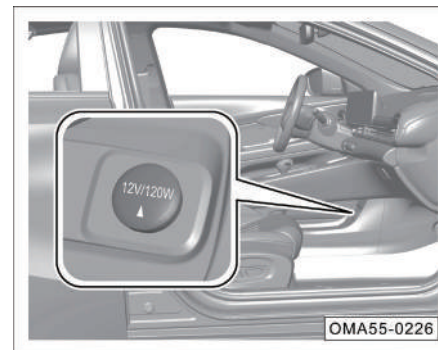

- Open the trim cover of 12V power supply, insert the power connector into the on-board 12V power supply, and start the vehicle.

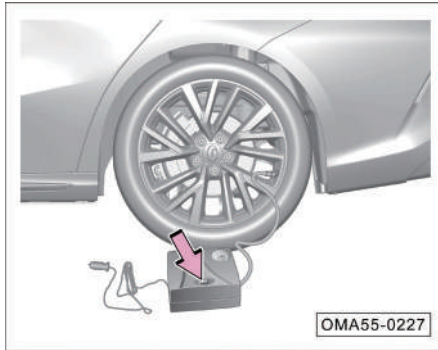

- Press the power button to start to inflate the tire, and observe the change in the indicated pressure on the tire pressure gauge. When the indicated pressure reaches the standard pressure, cut off the power to stop inflating the tire.

### **i** NOTE

The standard tire pressure label is attached to the B-pillar on the driver's side.

### Tire sealer

The tire sealer should be used as follows:



- Take out the inflator pump and the tire sealer from the trunk.
- Shake the bottle and connect the connector of inflator pump with the inflator tube fitting.

### CAUTION

- The tire sealer bottle shall not be placed upside down.
- The tire sealer is not edible, so inhalation or swallowing shall be avoided. If it is ingested into the body by accident, please don't induce vomiting and go to hospital immediately.
- Protect your skin or eyes against the tire sealer; otherwise, it may cause irritation to your skin or eyes. If the tire sealer touches the skin accidentally, it can be thoroughly cleaned with water and soap; If the tire sealer accidentally enters the eyes, immediately rinse with clean water. If you feel unwell, seek medical attention immediately.

## 8. Accident handling

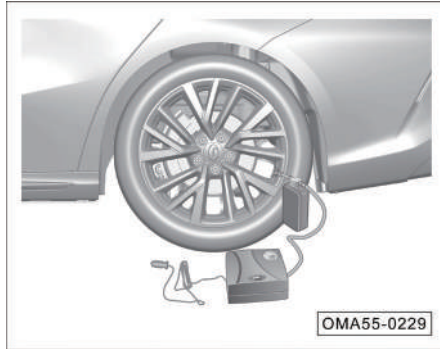

- Remove the tire valve cap.
- Screw the water hose connector onto the tire valve.

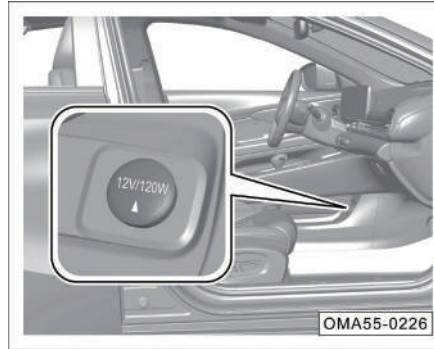

- Open the trim cover of 12V power supply, insert the power connector into the on-board 12V power supply, and start the vehicle.

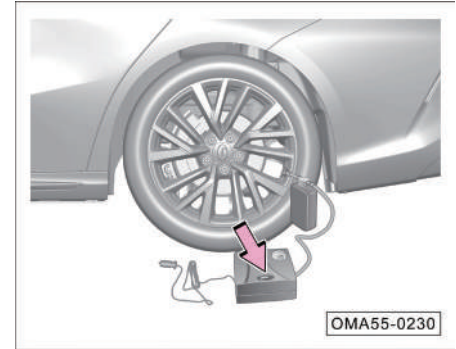

- Press the power switch button so that the sealer is injected into the tire. The air pressure is relatively high and between 2.8 bar and 4 bar during sealer application. After sealer application, the air pressure will drop to about 0.7-1.4 bar. When the air pressure reaches the standard value, switch off the power supply and screw on the valve cap.
- Disconnect the sealer tube, the inflator tube and the plug in turn, and put them back to the original position.
- Start the vehicle and drive 3~5 km at a speed of 20~60 km/h.

### CAUTION

If the tire pressure cannot reach the specified pressure within 10 min, it cannot be repaired.



- Park the vehicle in a safe place, and connect the inflator tube to the tire again.
- Observe the air pressure value and do inflation if there is a significant drop. If the tire pressure is lower than 1.3 bar, the tire cannot be repaired. You should go to the GAC Motor authorized shop for overhaul as soon as possible.

### WARNING

- After the tire repair with the tire sealer, go to the GAC Motor authorized shop for repair or go to a professional tire repair shop for repair as soon as possible.
- The driving speed should not exceed 80 km/h after the completion of the tire repair with tire sealer.

## 8. Accident handling

### 8.5 Replacing flat tire\*

#### Preparations

- Apply parking brake
- Set the gearshift lever to “P” gear.
- The vehicle power switch is set to the “OFF” gear and the hazard warning lamp is turned on.
- Place a warning triangle in a suitable position behind the vehicle.
- Find a suitable object to wedge the wheel in the diagonal position of the one to be replaced to prevent the vehicle from moving.
- Take out the driver’s tools and the spare tire.



#### WARNING

- Relevant regulations must be strictly followed.
- All passengers must leave the vehicle and wait in a safe place.



Set the wheel bolt removal wrench firmly on a wheel bolt, and unscrew the wheel bolt counterclockwise.



#### CAUTION

Loosen the wheel bolts just one turn before lifting the vehicle. After lifting the car, unscrew the wheel bolts completely, and then remove the flat tire.

#### Lifting the vehicle

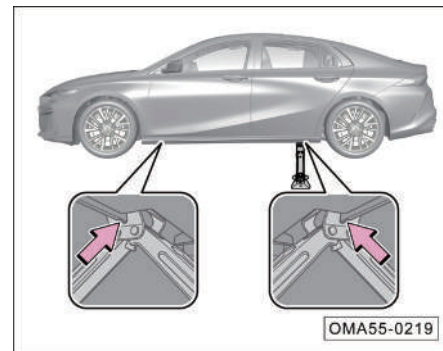

- Place the jack directly under the spine closest to the flat tire.
- Extend the jack high to ensure that the groove of the jack can engage with the spine.
- Check whether the jack is stable and tightly attached to the ground.



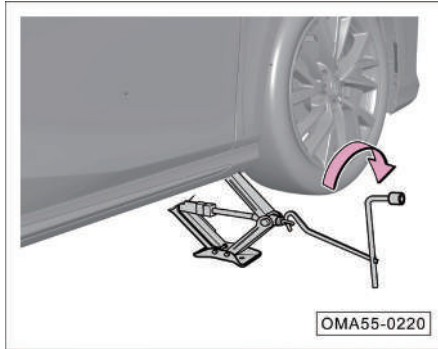

### ⚠ WARNING

Improper use of jacks will cause serious injury.

- The jack must be used on a hard and flat ground or a hard pad (not thicker than 1 cm) may be placed under the jack as needed.
- Strictly observe the jack operation precautions.
- If the vehicle tows a trailer, the trailer must be separated from the vehicle.
- In the lifting process, the vehicle condition should be continuously observed. If the vehicle body is found to be obviously inclined, the lifting should be stopped and the problem should be found out. Lifting should be carried out only after the problem is solved.

### ⚠ WARNING

- The jack supplied with the vehicle can only be used to lift the vehicle, and cannot be used to lift other heavy objects or vehicles.
- When the jack is in use, do not start the engine; otherwise accidents will occur.
- When lifting the vehicle with a jack, remember not to place any part of the body under the vehicle to avoid accidents.
- If it is really necessary to work under the vehicle, proper protective support must be placed under the vehicle.

- Assemble the wheel bolt removal wrench, the special wrench for jack and the jack.
- Extend the jack clockwise to lift the vehicle and lift the tire off the ground.

## 8. Accident handling

### Installing spare tire

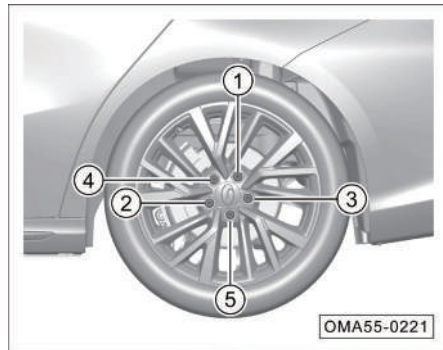

- Install the spare tire to the vehicle.
- Install all wheel bolts, and pre-tighten them with the wheel bolt removal wrench in the order of ① ~ ⑤ in the figure.
- Give a verbal alert to confirm that nobody is around the vehicle, and then rotate the jack wrench counterclockwise to lower the vehicle.
- Tighten all wheel bolts using the wheel bolt removal wrench.

- In order to avoid the noise of the vehicle during driving later on, please remember the locations of various tools, put them back in place after use and fix them.

### CAUTION

After installing the wheels, go to GAC Motor authorized shop in time to check the tightening torque of the wheel bolts ( $125 \pm 10\text{N}\cdot\text{m}$ ); otherwise the bolts may be loose when the vehicle is driving, which is very likely to cause traffic accidents.

### WARNING

- Threads on wheel bolts and hubs must be kept clean so that the bolts can be easily screwed and free of adhesions such as grease.
- During replacement of tires, if the bolts are rusty or difficult to screw, the bolts must be replaced and the threaded holes must be cleaned.
- After the spare tire is not in use, the spare tire must be reliably fixed at the original mounting place.

### 8.6 Microwave window

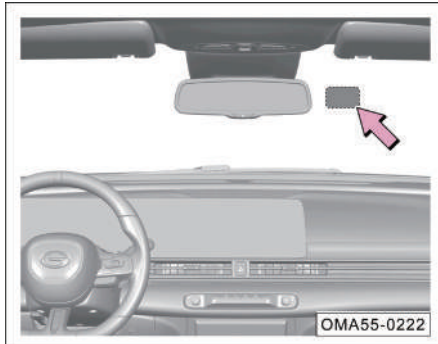

- The microwave window is set on the right of the front windshield corresponding to the interior rearview mirror.

#### **i** NOTE

The microwave window can be used for installation of ETC card.

### 8.7 Fuse

#### Instrument panel PDU

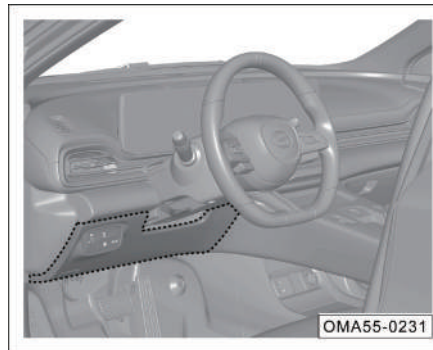

- Remove the left lower guard panel (dotted shaded part) of the instrument panel. Then the fuse on the instrument panel PDU is visible.

#### Engine compartment power distribution unit (PDU)

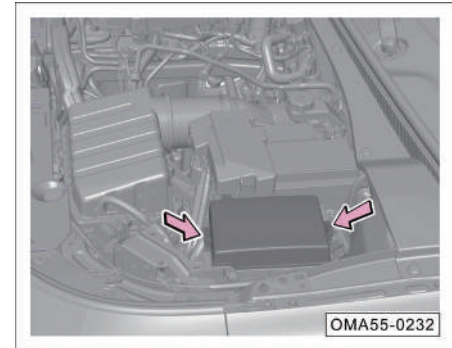

- Opening of engine hood
- Press the fixing clip in the direction of arrow to release the cover of the PDU.
- The fuse above the engine compartment PDU is exposed when the cover of the PDU is removed.

## 8. Accident handling

### Replacing fuse

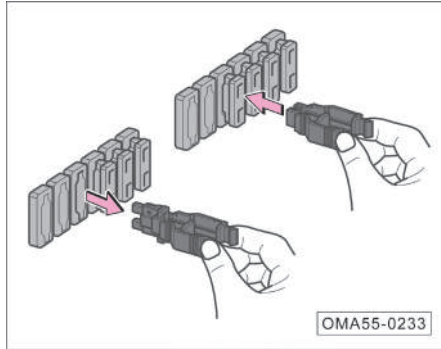

- Remove or install the fuse using the fuse puller in the engine compartment PDU.

### Blown fuse

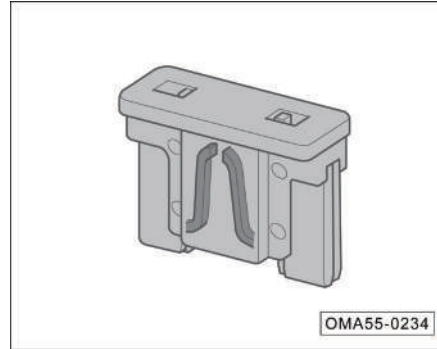

- If the fuse is blown, it is recommended to replace it in the GAC Motor authorized shop.

### **i** NOTE

Some electrical consumer may be equipped with multiple fuses, or multiple electrical consumers may share one fuse.

### **👁** CAUTION

- Be sure to turn off all electrical consumers before replacing the fuse.
- For fuse replacement, please consult the GAC Motor authorized shop.



### WARNING

- Fuses may not be reused.
- Do not use the fuse with a rated current value that is higher than the specified value; otherwise other components of the electrical system will be damaged.
- The use of unsuitable or patched fuses can cause a short circuit or even a fire.
- The color and identification of the replaced fuse must be exactly the same as the original fuse.
- Do not replace fuses with metal sheets, paper clips, etc.
- The inside of the PDU must be kept clean and moisture-proof.

## 8. Accident handling

### 8.7.1 Fuses in instrument panel PDU

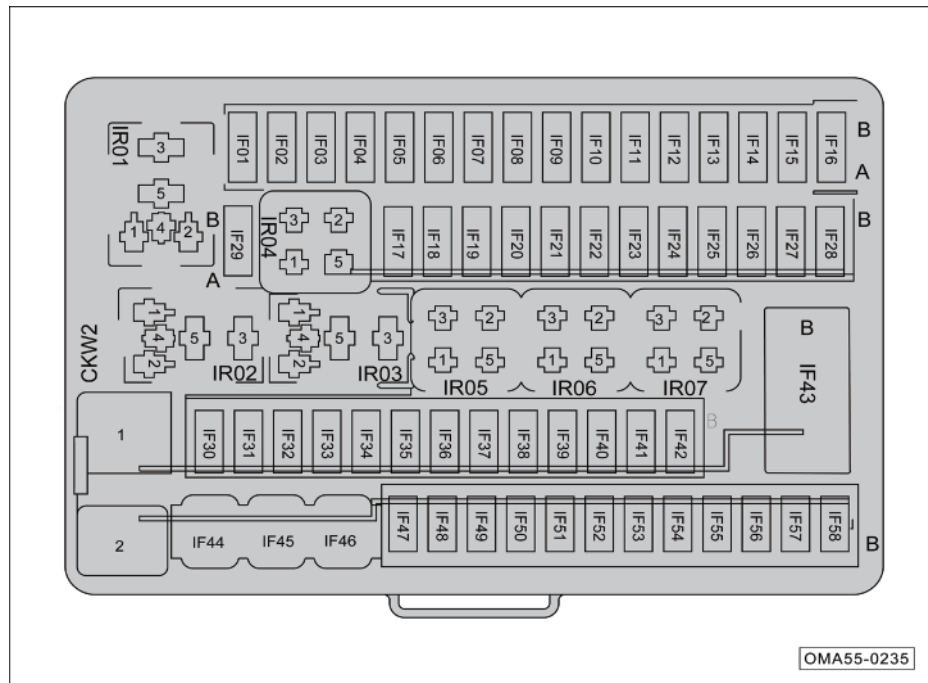

The picture is not guaranteed to be suitable for all vehicle models. Fuses for different vehicle models differ slightly with each other. Please refer to the actual vehicle.

## 8. Accident handling

No.	Rated value	Feature/component
IF01	20 A	Front 12V power outlet
IF02	7.5A	BCM
IF03	7.5A	ACU/DSM ECU *
IF04	7.5A	USB charging port */Mobile phone WCM */DVR USB port *
IF05	—	—
IF06	—	—
IF07	—	—
IF08	7.5A	T-BOX ECU*
IF09	7.5A	HVAC control unit/Mobile phone WCM*/RF receiver module/RLS*/Smart Bluetooth module*
IF10	10A	AV display (10.25-inch)/HCP/IAL*
IF11	7.5A	OBU/GSM/SVM ECU*/Left rear BSD ECU*/Right rear BSD ECU*/DSM ECU*
IF12	—	—
IF13	7.5A	Electronic anti-dazzling interior rearview mirror*/defogger relay (ER07)
IF14	7.5A	BCM
IF15	—	—
IF16	—	—
IF17	10A	SRS ECU
IF18	7.5A	ECM/7WDCT TCU/Electronic P gear actuator

No.	Rated value	Feature/component
IF19	7.5A	GWM/BCM
IF20	—	—
IF21	7.5A	Brake switch/ESPI
IF22	7.5A	EPS ECU/GSM
IF23	7.5A	On-board ETC unit/Power sunroof ECU*/Left front seat connector A (HVSM power supply)*/HCP/HVAC control unit
IF24	—	—
IF25	7.5A	Plasma generator*/ALS switch/front combination lamp (ALS motor power supply)
IF26	7.5A	LDW */MRR module */instrument cluster */ACU/T-BOX control unit */RPA ECU /AVM ECU *
IF27	—	—
IF28	—	—
IF29	—	—
IF30	—	—
IF31	20A	BCM (door lock power supply)
IF32	20A	BCM
IF33	20A	BCM (wiper power supply)
IF34	—	—

## 8. Accident handling

No.	Rated value	Feature/component
IF35	7.5A	GWM
IF36	15A	BCM (turn signal lamp power supply)
IF37	—	—
IF38	—	—
IF39	7.5A	Instrument cluster*/instrument cluster display (10.25-inch)
IF40	7.5A	Fuel filler cap lock motor/fuel filler cap lock relay (IR05)
IF41	7.5A	OBD DLC
IF42	—	—
IF43	Dark current switch	T-BOX ECU */HVAC control unit/mobile phone WCM */RF receiver module/RLS */smart Bluetooth module */AV system display (10.25-inch)/HCP/IAL */ on-board ETC unit/GSM/AVM ECU */left rear BSD ECU */right rear BSD ECU */driver status monitoring ECU *
IF44	—	—
IF45	30A	Right front door control module
IF46	30A	Left front door control module
IF47	20A	BCM (main lighting power supply 2)
IF48	20A	BCM (main lighting power supply 1)
IF49	10A	Left front seat connector A (HVSM power supply) *
IF50	15A	IG2 power supply

No.	Rated value	Feature/component
IF51	20A	Left front seat connector A (seat controller power supply) *
IF52	20A	Right front seat connector A (seat adjusting switch power supply) *
IF53	15A	BCM (windshield washer motor power supply)
IF54	20A	ACU
IF55	20A	Power sunroof ECU*
IF56	—	—
IF57	—	—
IF58	—	—
IR01	—	ACC relay
IR02	—	—
IR03	—	—
IR04	—	IG1 relay
IR05	—	Fuel filler cap lock relay
IR06	—	—
IR07	—	IG2 relay



### 8.7.2 Fuses in engine compartment PDU

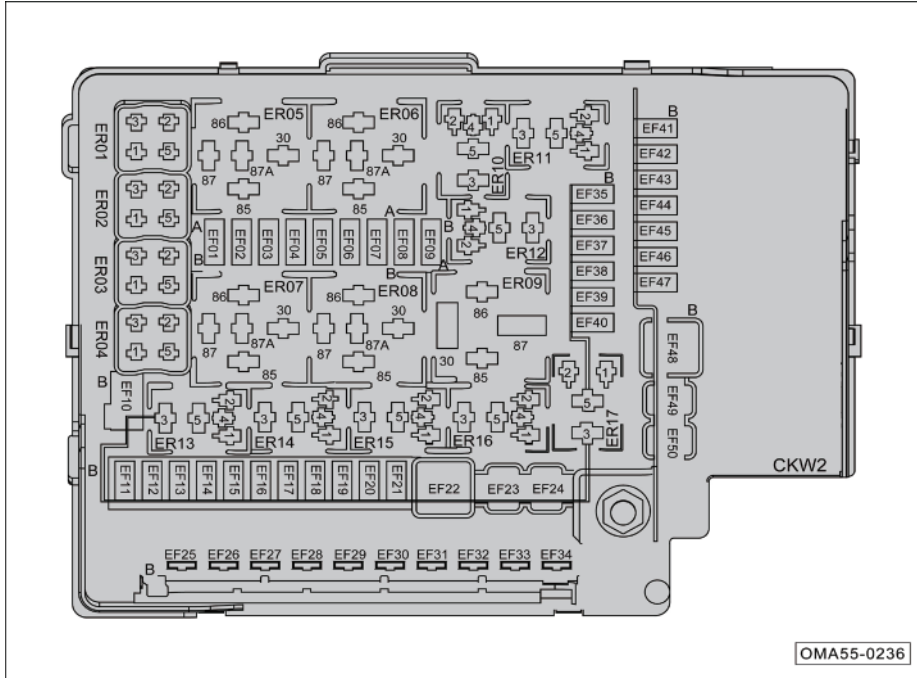

The picture is not guaranteed to be suitable for all vehicle models. Fuses for different vehicle models differ slightly with each other. Please refer to the actual vehicle.

## 8. Accident handling

No.	Rated value	Feature/component
EF01	—	—
EF02	—	—
EF03	—	—
EF04	7.5A	ECM
EF05	—	—
EF06	—	—
EF07	7.5A	Exterior rearview mirror heater
EF08	—	—
EF09	—	—
EF10	30A	7WDCT TCU
EF11	30A	7WDCT TCU
EF12	15A	Horn relay (ER03)/horn
EF13	30A	7WDCT TCU
EF14	7.5A	MRR module */LDW ECU *
EF15	—	—
EF16	20A	Fuel pump
EF17	20A	Wiper/wiper speed control relay (ER11)/wiper relay (ER12)
EF18	7.5A	Brake switch
EF19	7.5A	Main relay (ER17)/ECM
EF20	—	—

No.	Rated value	Feature/component
EF21	—	—
EF22	60A	To instrument panel PDU
EF23	40A	ESPI
EF24	30A	IG1 On
EF25	30A	Starter
EF26	40A	ACC power supply
EF27	40A	Blower
EF28	40A	Rear windshield defogger heater +/exterior rearview mirror heater *
EF29	—	—
EF30	50A	Cooling fan (low gear)
EF31	—	—
EF32	60A	To instrument panel PDU
EF33	60A	Cooling fan (high gear)
EF34	—	—
EF35	10A	Low speed fan relay (ER06)/high speed fan relay (ER09)/ Fuel pump relay (ER14)/water pump relay (ER02)
EF36	15A	Ignition coil 1/ignition coil 2/ignition coil 3/ignition coil 4
EF37	15A	ECM/Starter relay 1(ER15)/Starter relay 2(ER16)

## 8. Accident handling

No.	Rated value	Feature/component
EF38	10A	Upstream oxygen sensor/Downstream oxygen sensor/Compressor relay (ER04)
EF39	10A	PCV heater relay (ER10)/PCV heater/Canister vent valve/ Relief valve/Canister solenoid valve/Oil pump solenoid valve/Oil control valve (intake end)/Oil control valve (exhaust end)
EF40	10A	Left EAV valve */Right EAV valve *
EF41	—	—
EF42	—	—
EF43	10A	Electric water pump
EF44	—	—
EF45	7.5A	A/C compressor
EF46	20A	Left front seat connector A (HVSM and seat controller power supply) *
EF47	—	—
EF48	40A	ESPI
EF49	30A	Electronic P gear actuator
EF50	—	—
ER01	—	—
ER02	—	Water pump relay
ER03	—	Horn relay

No.	Rated value	Feature/component
ER04	—	Compressor relay
ER05	—	Blower relay
ER06	—	Low speed fan relay
ER07	—	Defogger relay
ER08	—	—
ER09	—	High speed fan relay
ER10	—	PCV heater relay
ER11	—	Wiper speed control relay
ER12	—	Wiper relay
ER13	—	—
ER14	—	Fuel pump relay
ER15	—	Starter relay 1
ER16	—	Starter relay 2
ER17	—	Main relay

## 8. Accident handling

### 8.7.3 Fuse in PFB

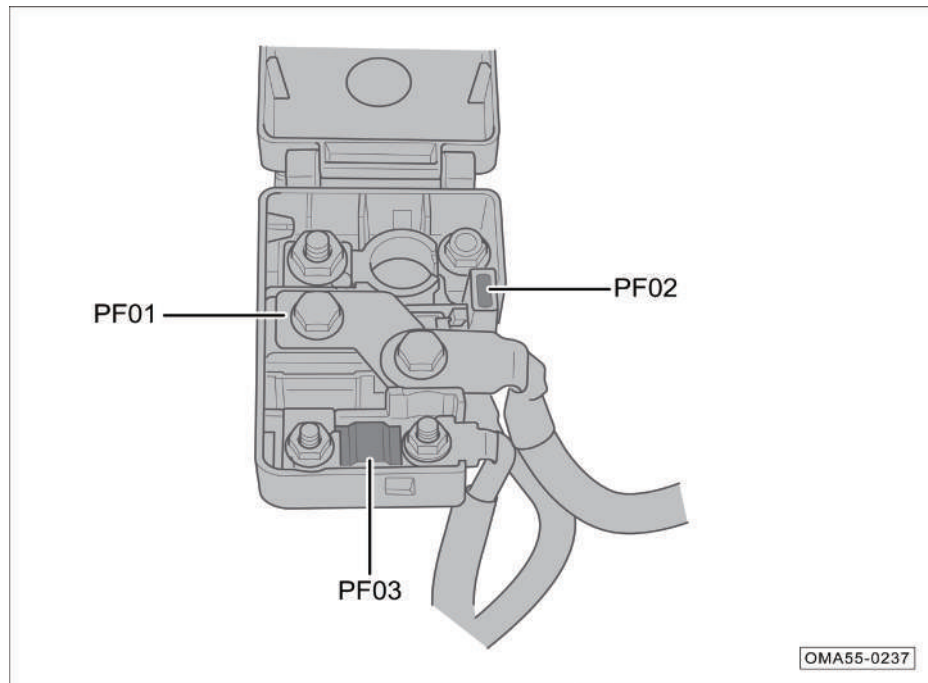

The picture is not guaranteed to be suitable for all vehicle models. Fuses for different vehicle models differ slightly with each other. Please refer to the actual vehicle.

No.	Rated value	Feature/component
PF01	300A	Starter/Engine compartment PDU/Alternator
PF02	7.5A	EBS
PF03	80A	EPS ECU

### 8.8 Emergency start

#### Jumper cable

If the engine cannot start because the battery is too low, it can be started by connecting this battery to the battery of another vehicle a jumper cable.

#### WARNING

- Engine compartment is a highly risky area, and improper operation can easily lead to casualties.
- Be sure to carefully read and observe the safety warning instructions related to battery operation before starting operation on the battery.

#### CAUTION

Before the jumper cable operation, be sure to turn off all electrical consumers of the vehicle with power shortage, such as headlights, A/C, AV system, etc.

While connecting the batteries of two vehicles, be sure to first connect the positive terminal and then the negative terminal.

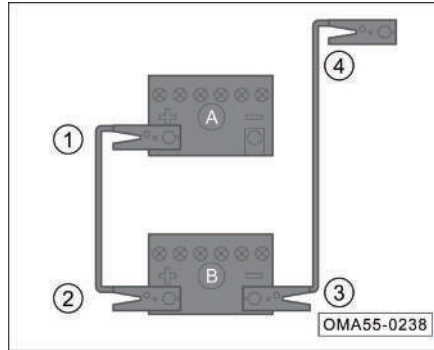

- Set the vehicle power switch to “OFF” position.
- Connect end ① of the red cable to the positive terminal (+) of the depleted battery “A”, and end ② to the positive terminal (+) of the power battery “B”.

- Connect end ③ of the black cable to the negative pole (-) of the power battery “B”, and connect end ④ to the engine block or a metal part firmly connected to the engine block of the vehicle with the depleted battery “A”.

#### CAUTION

Properly place the jumper cable to avoid contact between the cable and the moving parts of the engine.

- Start the engine of the vehicle with power battery and let it idle. Then, start the engine of the vehicle with the depleted battery till the engine runs smoothly.

## 8. Accident handling

---

### WARNING

- Be sure to turn off the headlamps before removing the jumper cables.
- Turn on the blower and rear windshield heater of the vehicle with the depleted battery to reduce the voltage peak generated when the cable is being removed.
- Remove the jumper cables with the engine running in the reverse order.

### WARNING

Improper use of jumper cables may cause battery explosion and serious injury.

- The voltage of the battery for power supply must be the same as that of the depleted battery, and the capacity of both batteries must be the same as possible. Otherwise, it may cause an explosion.
- Never expose the battery to an open flame, for fear of an explosion.
- Do not connect the negative cable directly to the negative pole of the depleted battery. There shall be no static electricity near the battery. Otherwise, the combustible gas produced by the battery may be ignited by sparks, causing an explosion accident.
- Never connect the negative cable to a fuel system component or a brake line. Never lean over the battery during operation. Be careful not to get burned by acid.

### WARNING

The jumper cable should be properly connected to the positive and negative terminals instead of other positions of the battery as mentioned above, otherwise it may cause blown fuse or failure of some vehicle functions, and GAC will not assume any responsibility for such damage.

### 8.9 Vehicle towing

If the vehicle needs to be towed, it shall be towed by the GAC Motor authorized shop or a professional towing company.

It is recommended to use a rollback tow truck for towing. If the conditions can not be met, a wheel-lift truck can also be used for towing the vehicle as appropriate.

#### Being towed by a rollback tow truck

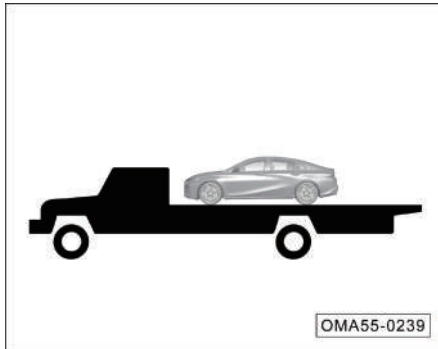

#### Being towed by a wheel-lift truck from the front

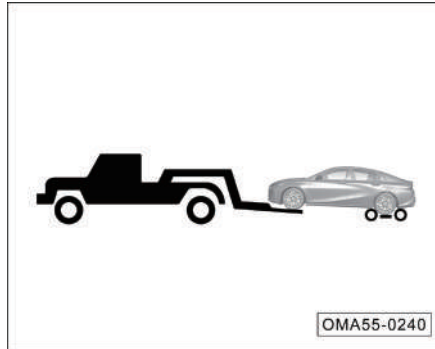

- Place a dolly under the rear wheels.

#### Being towed by a wheel-lift truck from the rear

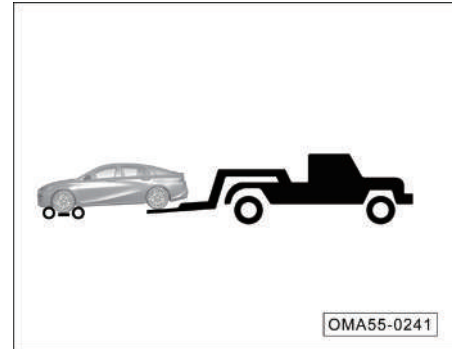

- Place a dolly under the front wheels.

## 8. Accident handling

### Emergency towing

If it is impossible to find a tow truck in an emergency, fasten the towing cable or towing chain in the emergency towing ring to temporarily tow the vehicle. However, this method is only suitable for low speed and short distance towing on a solid and flat road.

 **WARNING**

**In emergency towing, drive slowly to avoid violent operation. Excessive towing force will damage the vehicle**

### Installing a towing hook

For models with front transverse grille \*

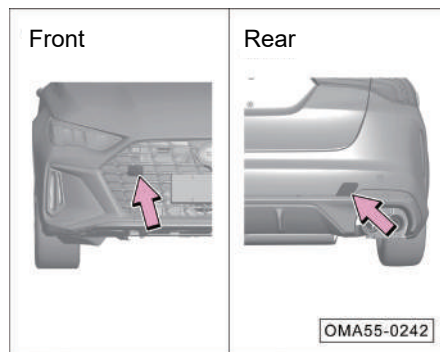

- Pry off the towing hook cover in the arrowed position using a slotted screwdriver wrapped with a cloth.

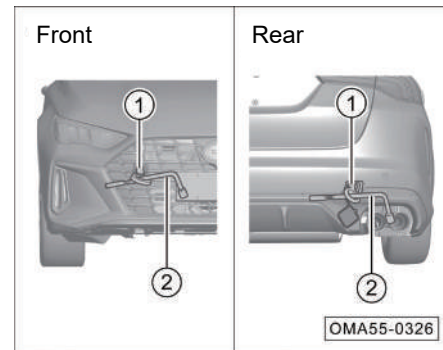

- Take out the towing hook ① and wheel bolt removal wrench ② from the tool kit in the trunk.
- Screw the towing hook ① clockwise into the thread hole.
- Insert the wheel bolt removal wrench ② into the round opening of the towing hook, and turn the wheel bolt removal wrench clockwise to make the towing hook be firmly screwed into the thread hole.



For models with front vertical grille \*

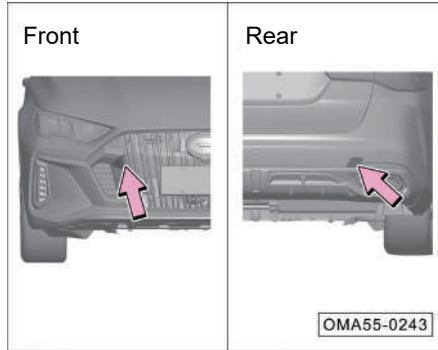

- Pry off the towing hook cover in the arrowed position using a slotted screwdriver wrapped with a cloth.

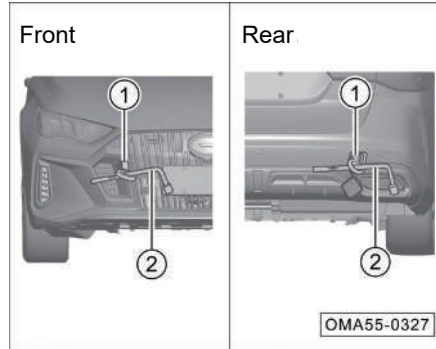

- Take out the towing hook ① and wheel bolt removal wrench ② from the tool kit in the trunk.
- Screw the towing hook ① clockwise into the thread hole.
- Insert the wheel bolt removal wrench ② into the round opening of the towing hook, and turn the wheel bolt removal wrench clockwise to make the towing hook be firmly screwed into the thread hole.

### Precautions for towing

Before emergency towing, be sure to follow the instructions below:

- Hazard warning lamps of both towing and towed vehicles must be turned on, and local traffic regulations must be complied with.
- The towing hook must be firmly tightened in the thread hole. Otherwise, the towing hook may slip out of the thread hole during towing.
- The towed vehicle must be shifted into "N" gear.
- For the towed vehicle, set the vehicle power switch to the "ON" position and turn the steering wheel back and forth to confirm that the steering wheel can be turned.

## 8. Accident handling

---

During the emergency towing, be sure to follow the instructions below:

- Start the engine and drive at a slow speed till the towing rope is tight and then accelerate the vehicle slowly.
- Be sure to drive steadily and avoid sharp acceleration, sharp deceleration or abrupt turning.
- During towing, the towed vehicle shall be braked earlier than in normal conditions with the brake pedal lightly depressed.
- During towing, the towing rope must always be in a tight state.

### 8.10 Getting out of a trap

If the vehicle is stuck on a soft road such as sandy, muddy or snowy road, follow the steps below to get out of a trap:

1. Observe the areas in front of and behind the vehicle to ensure that there are no obstacles.
2. Turn the steering wheel to the left and to the right to grind areas around the front wheels to remove mud, snow or sand trapped around the tires.
3. Place wooden blocks, stones or other materials to help increase tire friction.
4. Start the engine and accelerate the vehicle slowly to get the vehicle out of the trap.
5. If the vehicle still cannot get out of the trap after attempts for several times, it is required to have a tow truck for rescue.

#### **i** NOTE

In the acceleration process, human assistance can be provided to push the vehicle from the front and rear for driving the vehicle out of the trap.

## 9. Environmental protection information

### 9.1 Environmental protection information code

No.	Type	Environmental protection information code	No.
1	GAC7153BCW6A	CN QQ G6 Z2 0B82000076	000001
			000002
			000003
			000004

## 9. Environmental protection information

### 9.2 Environmental protection information

Environmental protection information	Type
	GAC7153BCW6A
Engine model/manufacture	4A15J2/Guangzhou Qisheng Powertrain Co., Ltd.
Catalytic converter model/manufacture	Upstream: 02515700/Upstream: Sanshui Branch of Faurecia (Guangzhou) Automotive Systems Co., Ltd. Downstream: 02915700/Downstream: Sanshui Branch of Faurecia (Guangzhou) Automotive Systems Co., Ltd.
Painting/carrier/packaging manufacturer	Coating: Upstream: Unit 1: Wuxi Weifu Environmental Catalysts Co., Ltd; Downstream: Unit 1: Wuxi Weifu Environmental Catalysts Co., Ltd. Front: Unit 1: NGK AUTOMOTIVE CERAMICS (Suzhou); Downstream: Unit 1: Corning (Shanghai) Co., Ltd. Upstream: Sanshui Branch of Faurecia (Guangzhou) Automotive Systems Co., Ltd; Downstream: Sanshui Branch of Faurecia (Guangzhou) Automotive Systems Co., Ltd.
Particulate filter model/manufacture	/
Painting/carrier/packaging manufacturer	/
Canister model/manufacture	2140003CSV01/Guangdong Hengbo Filter Co., Ltd.
Oxygen sensor model/manufacture	Upstream: ZFAS; Downstream: LSF 4/Upstream: CHANGSHU NGK SPARK PLUG CO., LTD; Downstream: UAES
Crankcase emission control device model/manufacture	10090082040000/Shentong Technology Group Co., Ltd.
EGR model/manufacture	/
OBD system supplier	UAES
ECU model/manufacture	UD8/UAES
Transmission type/gear number	Automatic/7
Muffler model/manufacture	Upstream: MA5515G1; Downstream: MA5515G3/Tenneco (China) Co., Ltd.
Turbocharger model/manufacture	MGT1446Z/Garrett Motion Technology (Wuhan) Co., Ltd.
Intercooler type	Air-to-water

## 9. Environmental protection information

Environmental protection information	Type
	GAC7153BCW6A
Engine model/manufacture	4A15J2/Guangzhou Qisheng Powertrain Co., Ltd.
Catalytic converter model/manufacture	Upstream: 02515700/Upstream: Sanshui Branch of Faurecia (Guangzhou) Automotive Systems Co., Ltd. Downstream: 02915700/Downstream: Sanshui Branch of Faurecia (Guangzhou) Automotive Systems Co., Ltd.
Painting/carrier/packaging manufacturer	Coating: Upstream: Unit 1: Wuxi Weifu Environmental Catalysts Co., Ltd; Downstream: Unit 1: Wuxi Weifu Environmental Catalysts Co., Ltd. Front: Unit 1: NGK AUTOMOTIVE CERAMICS (Suzhou); Downstream: Unit 1: Corning (Shanghai) Co., Ltd. Upstream: Sanshui Branch of Faurecia (Guangzhou) Automotive Systems Co., Ltd; Downstream: Sanshui Branch of Faurecia (Guangzhou) Automotive Systems Co., Ltd.
Particulate filter model/manufacture	/
Painting/carrier/packaging manufacturer	/
Canister model/manufacture	2140003CSV01/Guangdong Hengbo Filter Co., Ltd.
Oxygen sensor model/manufacture	Upstream: ZFAS; Downstream: LSF 4/Upstream: CHANGSHU NGK SPARK PLUG CO., LTD; Downstream: UAES
Crankcase emission control device model/manufacture	10090082040000/Shentong Technology Group Co., Ltd.
EGR model/manufacture	/
OBD system supplier	UAES
ECU model/manufacture	UD8/UAES
Transmission type/gear number	Automatic/7
Muffler model/manufacture	Upstream: 3W007; Downstream: 1W011/Guangzhou Sango Automotive Parts Co., Ltd.
Turbocharger model/manufacture	MGT1446Z/Garrett Motion Technology (Wuhan) Co., Ltd.
Intercooler type	Air-to-water

## **9. Environmental protection information**

---

**A**

A/C air outlet..... 136

ACC \* ..... 202

Accessories and modification ..... 126

A/C filter ..... 293

Anti-lock brake system (ABS)..... 198

APP on mobile phone..... 170

Around View Monitor (AVM)\* ..... 260

AV system..... 137

**B**

Basic operation of body anti-theft system..... 93

Basic operations ..... 142

Basic operations of Bluetooth key ..... 66

Battery ..... 292

Bluetooth key\* ..... 63

Brake fluid..... 290

Brake system..... 189

BSD system\* ..... 233

**C**

Cab ..... 36

Cabin monitoring system\* ..... 248

Cases where the airbags may deploy ..... 23

Cases where the airbags might not deploy ..... 24

Child restraint ..... 25

Child safety seat ..... 26

Coolant ..... 286

Correct installation of child safety seat ..... 30

Correct sitting posture of the driver and passengers... 12

Cruise control system \* ..... 200

**D**

Dimensions & parameters of vehicle ..... 307

Door..... 82

## Index

---

Door latch and inside handle .....	174
Door lock system .....	77
Door opening warning system* .....	238
Download, installation and use instructions of Bluetooth key .....	63
Driver assistance system .....	200
Driver's tools, spare tire .....	315
Driving essentials .....	270
Driving in running-in period .....	268
Driving skills .....	268

## E

Efficient use of vehicle .....	272
Electric power steering (EPS) .....	267
Electronic service brake system .....	196
Emergency mechanical key .....	77
Emergency Rescue .....	171
Emergency start .....	335

Emergency towing .....	338
Engine oil .....	283
Environmental protection information .....	342
Environmental protection information code .....	341
EPB system (EPB) .....	192
ESP (ESP) .....	196
ESP (ESP) TOP SPEED mode .....	198
Exhaust gas hazard .....	34
Exhaust sound wave* .....	188
Exterior rearview mirror .....	106
External maintenance .....	276

## F

Feature list .....	172
Fire prevention .....	272
Forward collision mitigation (FCM)* .....	220
Front seat .....	111
Fuel .....	281



Fuse.....325  
Fuse in PFB.....334  
Fuses in engine compartment PDU.....331  
Fuses in instrument panel PDU.....328

**G**

GAC Motor T-BOX\* .....169  
General description ..... 11, 25, 128, 169  
Getting out of a trap.....340

**H**

Headrest.....110  
HHC (HHC).....199  
Hood.....85  
HVAC system ..... 128, 129

**I**

Identifications.....305  
Indicator lamp.....55

Information about child safety seat.....28  
Inspecting and adding fluids.....281  
Instruction for the gear.....177  
Instrument cluster .....38  
Intelligent high beam\* .....231  
Intelligent speed limit\* .....219  
Interior .....7  
Interior lamps.....100  
Internal maintenance .....274

**L**

Lamps and vision.....94  
LKA\* .....225  
Local music.....155

**M**

Maintenance instructions.....274  
Microwave window .....325

## Index

---

Mobile phone wireless charging system\* ..... 121

### P

Parameters of transmission, chassis and lamps ..... 311

PAS..... 253

Personal account..... 148

power outlet..... 119

Power sunroof ..... 89

Power window ..... 86

Precautions for Bluetooth key..... 64

### R

Radar and camera sensors \* ..... 242

Radio ..... 154

Rear approach alert system ..... 241

Rear approach alert system\* ..... 241

Rear crossing traffic alert system\* ..... 236

Rear seat..... 115

Remote control key..... 59

Replacing bulbs ..... 295

Replacing flat tire ..... 322

Reverse image system \* ..... 258

RPA..... 253

### S

Safe driving..... 11

Safety label..... 35

Seat belt ..... 13, 15

Seats and storage facilities..... 110

Service brake..... 189

Shut down the engine..... 176

Starting and driving..... 174

Start the engine ..... 175

Steering wheel..... 36

Storage facilities ..... 116

Sun visor..... 109

Supplemental restraint system (SRS) ..... 18  
System setting ..... 163  
System settings ..... 158

**T**

Tire chain ..... 303  
TPMS ..... 246  
Traffic Jam Assist (TJA)/ Integrated cruise assist (ICA)\* .  
211  
Traffic safety inspection ..... 268  
Trunk ..... 124  
Trunk lid ..... 83

**U**

Use of reflective vest ..... 317  
Use of warning triangle ..... 316

**V**

Vehicle locking and unlocking ..... 59

Vehicle mass, engine and fluid parameters ..... 308  
Vehicle towing ..... 337

**W**

Wheels ..... 298  
Why must you fasten the seat belt ..... 13  
Windshield ..... 105  
Windshield washer fluid and wiper blades ..... 288  
Wiper combination switch ..... 103

