

Thanks for choosing the vehicle manufactured by GAC Motor Co., Ltd. (hereinafter referred to as “GAC Motor”). For a better driving pleasure, please read the *Owner's Manual* carefully. Through this manual, you can fully understand the operation methods and precautions of the vehicle. Proper operation of the vehicle can improve driving safety and prolong the service life of the vehicle.

The *Warranty Manual* supplied with the vehicle clearly describes the warranty services provided by GAC Motor and the regular maintenance of the vehicle. Please read this manual carefully to know your rights and responsibilities.

Please bring this manual with you for your reference when necessary.

In case of any doubts about this manual, please contact the GAC Motor authorized shop for detailed explanation.

If you have any suggestions or recommendations on your vehicle, please contact GAC Motor through the service hotline: +86-400-158-9999.

We are grateful for your support and love for GAC Motor. Have a nice drive!

GAC Motor Co., Ltd.

Safety Instructions

The safety of you and the passengers is crucial, so driving safely is an important responsibility of the driver.



In order to make clear the safety precautions, we provide operation steps and precautions through the various signs on the vehicle and this manual, reminding you of the potential dangers that will hurt you or the passengers.

It is impossible to list all the precautions for danger related to operation and maintenance of the vehicle in the manual, so it is up to you to make a correct judgment in time.

Safety instructions are available in many forms, including:

- Safety signs pasted on the vehicle.
- Safety notes - the texts preceded by symbols , ,  and warning words including "WARNING", "CAUTION" or "NOTE"

The meaning of warning words including "WARNING", "CAUTION" and "NOTE" are as follows:

 WARNING	Very important instructions of which the nonobservance can cause casualties.
 CAUTION	Important instructions of which the nonobservance can cause damage to the vehicle.
 NOTE	General instructions of which the nonobservance could not cause injuries.

- Some paragraphs of this manual do not apply to all vehicle models. For the description of options, the title of them is followed by the symbol "**".
- Unless otherwise specified, the directions of the vehicle (front, rear, left and right) referred to in this manual are based on the traveling direction of the vehicle.
- ENGINE START/STOP button or mechanical ignition switch is provided for the models of the vehicle series, and except for special description, the uniform term of "ignition switch" is used.

1. Important safety precautions	1
2. Picture index	3
2.1 Exterior	3
2.2 Interior	6
3. Instructions for safe operation.....	10
3.1 Safe driving.....	10
3.1.1 General.....	10
3.1.2 Correct sitting posture of the driver and passengers	11
3.2 Seat belt	12
3.2.1 Why must you fasten the seat belt.....	12
3.2.2 Seat belt.....	13
3.3 Supplemental restraint system (SRS)	17
3.3.1 Cases where the airbags might deploy...	22
3.3.2 Cases where the airbags might not deploy	23
3.4 Safe ride of children.....	24
3.4.1 General	24
3.4.2 Child safety seat	25
3.4.3 Information about child safety seat.....	26
3.4.4 Installing the child safety seat correctly ..	28
3.5 Exhaust gas hazard	32

3.6 Safety label.....	33
4. Operation of systems and equipment	34
4.1 Driving space	34
4.1.1 Steering wheel	34
4.1.2 Instrument cluster	36
4.1.3 Indicator lamp	45
4.2 Vehicle locking and unlocking.....	49
4.2.1 Remote control key	49
4.2.2 Mechanical key	54
4.2.3 Door lock system	54
4.2.4 Door	60
4.2.5 Liftgate	61
4.2.6 Engine hood.....	66
4.2.7 Power window.....	68
4.2.8 Electric sunroof	70
4.2.9 Basic operation of body anti-theft system	73
4.3 Lamps and vision.....	74
4.3.1 Exterior lamps.....	74
4.3.2 Interior lamp	81
4.3.3 Wiper combination switch	83
4.3.4 Windshield	86
4.3.5 Rearview mirror	87
4.3.6 Sun visor	90

Table of Contents

4.4	Seats and storage facilities.....	90
4.4.1	Head restraints	90
4.4.2	Front seats.....	91
4.4.3	Rear seats	93
4.4.4	Storage facilities	94
4.4.5	USB port / power outlet.....	97
4.4.6	Mobile phone wireless charging system*	99
4.4.7	Trunk.....	102
4.4.8	Luggage rack	105
4.4.9	Accessories and modification	105
4.5	A/C system	107
4.5.1	General	107
4.5.2	A/C system	108
4.5.3	A/C air outlet.....	115
4.6	AV system.....	116
4.6.1	Control panel	116
4.6.2	Control buttons on steering wheel	117
4.6.3	Radio player*.....	119
4.6.4	Basic operation*.....	122
4.6.5	Radio*.....	124
4.6.6	USB media play	125
4.6.7	Bluetooth function*.....	126
4.6.8	System settings	128
4.6.9	Vehicle settings.....	130
4.7	Emergency rescue.....	132

5. Driving guide.....	133
5.1 Starting and driving.....	133
5.1.1 Ignition switch	133
5.1.2 Engine start.....	135
5.1.3 Engine shutdown	136
5.1.4 Gear description	137
5.2 Brake system	141
5.2.1 Service brake	141
5.2.2 Electric park brake (EPB)*	144
5.3 Electronic service brake system	148
5.3.1 Electronic stability program (ESP)	148
5.3.2 Anti-lock brake system (ABS)	150
5.3.3 Hill hold control (HHC)	151
5.3.4 Hill Descent Control (HDC).....	151
5.4 Driver assistance systems.....	152
5.4.1 Cruise control*	152
5.4.2 Adaptive cruise control (ACC)*	154
5.4.3 Traffic Jam Assist (TJA)/ Integrated cruise assist (ICA)*	164
5.4.4 Forward collision warning system *	170
5.4.5 Autonomous emergency braking (AEB)*.....	172
5.4.6 Pedestrian detection system *	175
5.4.7 Lane keeping aid (LKA) system*	177
5.4.8 Intelligent high beam *	183

<ul style="list-style-type: none"> 5.4.9 Radar and camera sensors * 185 5.4.10 Tire pressure monitoring system (TPMS)188 5.4.11 Particulate filter 190 5.5 Parking assist system (PAS)..... 191 <ul style="list-style-type: none"> 5.5.1 Reversing parking aid (RPA) 191 5.5.2 Reverse image system * 194 5.5.3 Around view monitor (AVM)* 196 5.6 Electric power steering (EPS)..... 200 5.7 Driving skills 201 <ul style="list-style-type: none"> 5.7.1 Driving safety inspection 201 5.7.2 Driving during running-in period 201 5.7.3 Driving essentials 203 5.7.4 Efficient use of vehicle 205 5.7.5 Fire prevention 206 6. In-service maintenance 207 <ul style="list-style-type: none"> 6.1 Maintenance instructions 207 6.2 Interior maintenance 207 6.3 Exterior maintenance 209 6.4 Checking and adding fluids 213 <ul style="list-style-type: none"> 6.4.1 Fuel 213 6.4.2 Engine oil 215 6.4.3 Coolant 218 6.4.4 Windshield washer fluid and wiper blades 220 	<ul style="list-style-type: none"> 6.4.5 Brake fluid 222 6.4.6 Battery 224 6.5 A/C filter 226 6.6 Replacing bulb 228 6.7 Wheels 231 6.8 Tire chain 236 7. Technical data 238 <ul style="list-style-type: none"> 7.1 VIN 238 7.2 Vehicle parameters 240 7.3 Vehicle mass & parameters of engine and fluids 241 7.4 Specifications of transmission, chassis and bulb 244 8. Accident handling 247 <ul style="list-style-type: none"> 8.1 Driver's tools, first aid kit and spare tire 247 8.2 Use of warning triangle 248 8.3 Use of reflective vest 249 8.4 Replacing flat tires 249 8.5 Microwave window 252 8.6 Fuse 252 <ul style="list-style-type: none"> 8.6.1 Fuses in instrument panel PDU 255 8.6.2 Fuses in engine compartment PDU 258
---	---

Table of Contents

8.6.3	Fuses in battery PDU.....	261
8.7	Emergency start	262
8.8	Towing	263
8.9	Getting out of a trap.....	266

1. Important safety precautions

◆ Be sure to fasten the seat belt correctly

The seat belt is the best protection device in the event of a collision. Airbags are only designed as auxiliaries, rather than replacements, of the seat belts, so even if the vehicle is equipped with airbags, make sure that you and the passengers always fasten the seat belts correctly.

◆ Do not leave children in an unattended vehicle

Do not leave children in an unattended vehicle, as injury or even death may occur if they trigger a control device accidentally, or when the vehicle is moved accidentally and collided with other objects due to their mis-operation, and besides, the temperature inside the vehicle may reach an extreme condition, depending on the ambient temperature.

◆ Protect all children

Children aged 12 or under should be properly restrained in the rear seats rather than the front seats. Child safety seats shall be used for infants and toddlers; and child safety seats and three-point seat belts shall be used for older children.

◆ Beware of danger of airbag

Airbags can save lives, but they can also cause serious or fatal injuries to occupants who are too close to the airbags or improperly restrained.

Airbags pose the greatest risk to infants, toddlers and short adults, so please follow all instructions and warnings in this manual.

◆ Never drink and drive

Drinking alcohol, even a little, will reduce your response capability, and your reaction time after drinking will become longer, so drinking and driving is strictly prohibited.

◆ During driving, please abide by the road traffic safety laws and yield to pedestrians.

◆ Pay due attention to driving safety

Traffic accident will occur if you are busy answering the phone or handling other things so that you cannot pay attention to road conditions, other traffics and pedestrians during driving. Please avoid distraction during driving.

◆ Control speed

Excessive speed is one of the main causes of traffic accidents. The faster the speed is, the greater the risk will be. Therefore, please choose the appropriate speed for safe driving according to the actual road conditions.

◆ Regular maintenance

Tire burst or mechanical failure is very dangerous. In order to reduce the possibility of such problems, please check the tire pressure and status frequently, and carry out regular maintenance as specified in the *Warranty Manual*.

1. Important safety precautions

Event data recorder (EDR)

This vehicle is equipped with an event data recorder (EDR). The EDR is mainly designed to record data in the event of certain collisions or risk of collisions (such as airbag deployment or collision with a barrier), so as to help you understand the operation condition of the vehicle system. EDR is specially used to record data related to vehicle dynamic control and safety systems in a short period of time. However, depending on the severity and type of collision, data may not be recorded, or recorded data may be overwritten by new data.

The data specially recorded by the EDR of this vehicle include:

- Status of driver depressing the brake pedal (if applicable).
- Vehicle speed.
- Vehicle longitudinal acceleration.
- Vehicle identification number

These data help you better understand the situation in the event of a collision and personal injury, and are used for accident analysis.

i NOTE

The EDR will record data only when a certain degree of collision occurs to the vehicle; EDR will not record data during normal driving.

EDR data disclosure

Except for the following circumstances, GAC Motor will not disclose the data recorded in the EDR to third parties:

- Reaching an agreement with the owner (or the lessee of the rental vehicle).
- At the official request of the police, courts or government agencies.

If necessary, the data will be used in:

- Research on vehicle safety performance.

How to obtain EDR data reading tool

Special technical equipment is required to read EDR data. For more information, please contact GAC Motor authorized shop.

2.1 Exterior

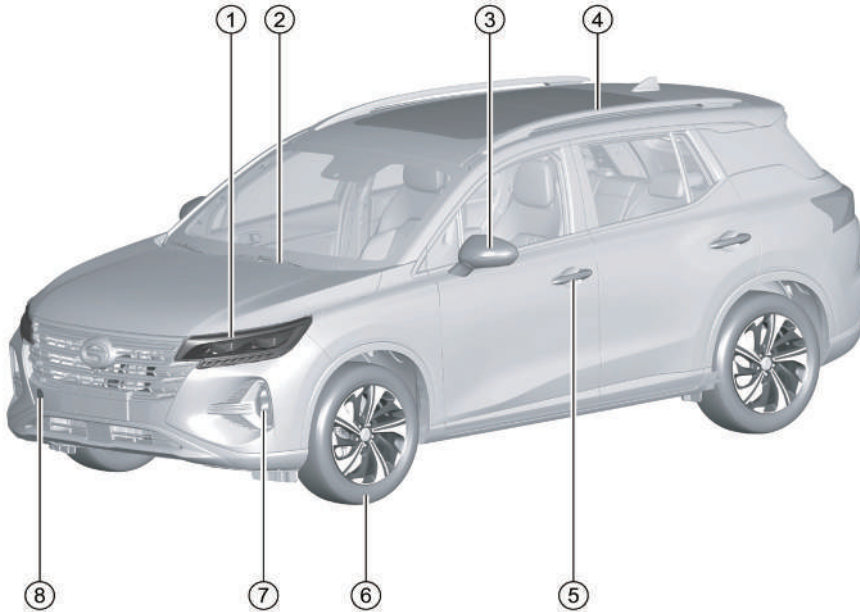

- ① Front combination lamp
 - Turning on lamps => [See page 74](#)
 - Replacing bulbs => [See page 228](#)
 - Specifications of front combination lamp bulb => [See page 246](#)
- ② Front wiper
 - Front windshield wiper blade => [See page 221](#)
- ③ Exterior rearview mirror => [See page 88](#)
 - Side turn signal lamp => [See page 75](#)
 - Specifications of side turn signal lamp => [See page 246](#)
- ④ Luggage rack* => [See page 105](#)
- ⑤ PEPS system* => [See page 59](#)
 - Door lock hole => [See page 55](#)
- ⑥ Wheel => [See page 231](#)
- ⑦ Front fog lamp* => [See page 78](#)
 - Specifications of front fog lamp* => [See page 246](#)
- ⑧ Front towing eye => [See page 265](#)

2. Picture index

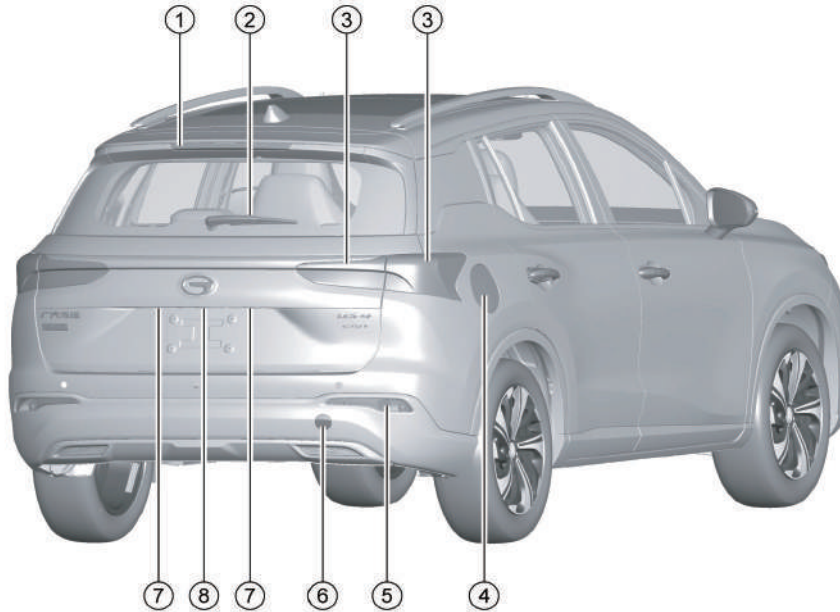

- ① High-mounted stop lamp
 - Specifications of high-mounted stop lamp => [See page 246](#)
- ② Rear wiper
 - Replacing rear windshield wiper blades => [See page 222](#)
- ③ Rear combination lamp
 - Specifications of rear combination lamp bulb => [See page 246](#)
- ④ Fuel tank cap => [See page 213](#)
- ⑤ Rear fog lamp => [See page 78](#)
 - Specifications of rear fog lamp => [See page 246](#)
- ⑥ Rear towing eye => [See page 265](#)
- ⑦ License plate lamp
 - Specifications of license plate lamp => [See page 246](#)
- ⑧ Liftgate unlocking button => [See page 60](#)

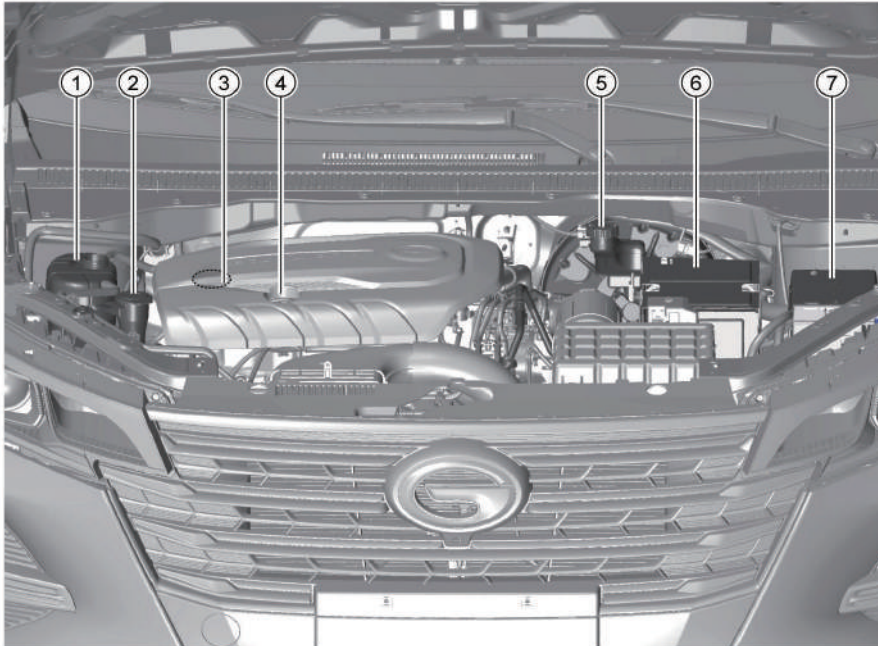

Engine compartment

- ① Expansion tank => [See page 219](#)
- ② Windshield washer fluid reservoir => [See page 220](#)
- ③ Oil filler cap => [See page 217](#)
- ④ Oil dipstick => [See page 216](#)
- ⑤ Brake fluid reservoir => [See page 223](#)
- ⑥ Battery => [See page 224](#)
- ⑦ Engine compartment PDU => [See page 258](#)

2. Picture index

2.2 Interior

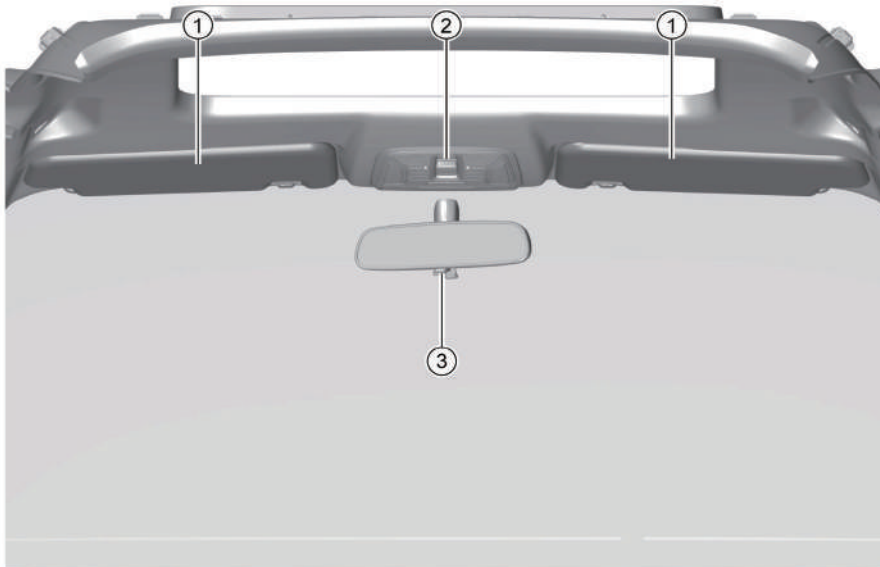

- ① Sun visor => [See page 90](#)
- ② Front dome lamp => [See page 81](#)
- Electric sunroof control button => [See page 70](#)
- Emergency call button* => [See page 132](#)
- Spectacle case => [See page 96](#)
- ③ Interior rearview mirror => [See page 87](#)

2. Picture index

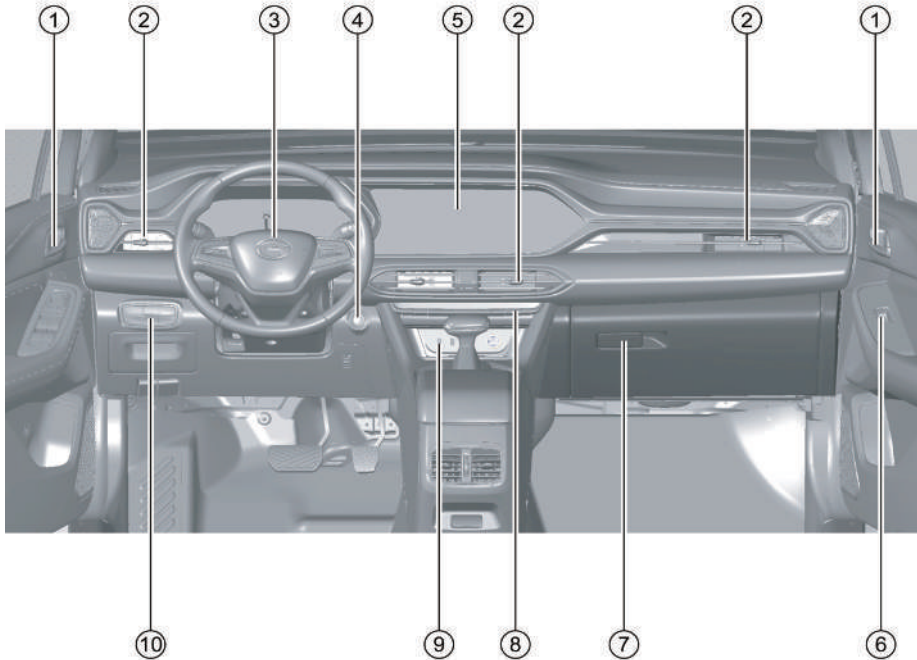

- ① Door latch and inside handle => [See page 55](#)
- ② A/C air outlet => [See page 115](#)
- ③ Steering wheel => [See page 34](#)
 - Steering wheel buttons => [See page 35](#)
 - Driver's frontal airbag => [See page 18](#)
- ④ ENGINE START STOP button * => [See page 133](#)
- ⑤ AV system => [See page 116](#)
- ⑥ Passenger's power window control button => [See page 69](#)
- ⑦ Glove box opening handle => [See page 96](#)
- ⑧ A/C system control panel => [See page 108](#)
- ⑨ USB interface => [See page 97](#)
- ⑩ Instrument panel left switch block:
 - Manual headlamp leveling knob* => [See page 78](#)
 - Hill descent control (HDC) button => [See page 151](#)
 - ESP OFF button => [See page 148](#)
 - Liftgate unlocking button* => [See page 62](#)

2. Picture index

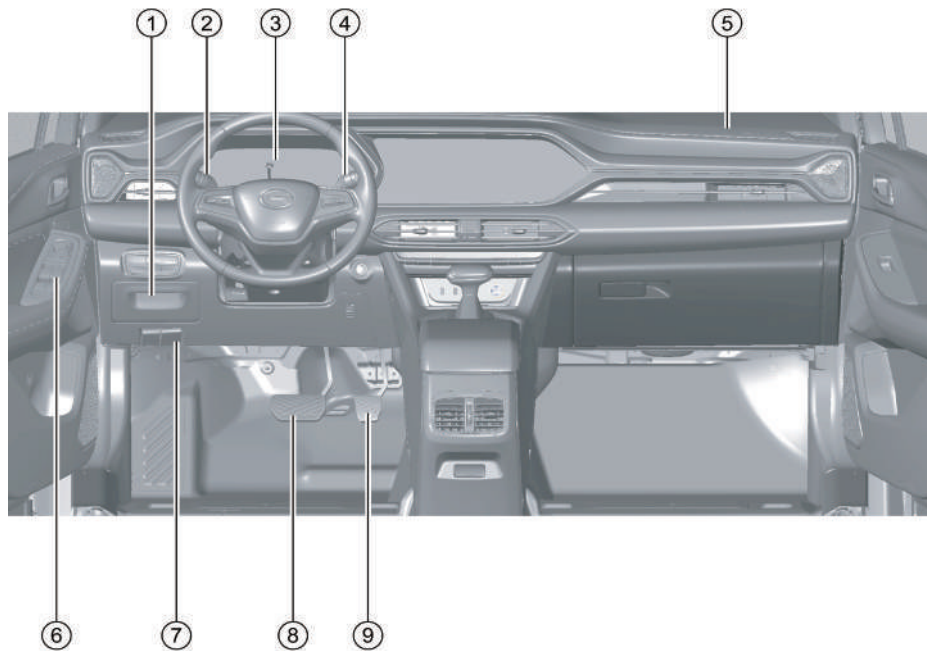

- ① Storage box on lower protective plate of cab => [See page 95](#)
 - Instrument panel PDU => [See page 255](#)
- ② Lamplight combination switch => [See page 74](#)
- ③ Instrument cluster => [See page 36](#)
 - Indicator lamps => [See page 45](#)
- ④ Wiper combination switch => [See page 83](#)
- ⑤ Front passenger's frontal airbag => [See page 19](#)
- ⑥ Driver's power window control button => [See page 68](#)
 - Central locking control button => [See page 54](#)
 - Exterior rearview mirror adjusting button => [See page 88](#)
- ⑦ Engine hood release handle => [See page 66](#)
 - Fuel filler cap release lever => [See page 213](#)
- ⑧ Brake pedal
- ⑨ Accelerator pedal

2. Picture index



- ① Power switch => [See page 116](#)
- ② Main interface control button => [See page 116](#)
- ③ Volume control knob => [See page 116](#)
- ④ EPB button* => [See page 144](#)
- ⑤ AutoHold button* => [See page 147](#)
- ⑥ Transmission gearshift lever => [See page 137](#)
- ⑦ AVM button * => [See page 196](#)
- ⑧ ECO mode button* => [See page 139](#)

3. Instructions for safe operation

3.1 Safe driving

3.1.1 General

This section introduces important information, operating essentials, recommendations and safety precautions for safe driving. For the safety of you and the passengers, please read carefully and follow the relevant regulations.

NOTE

Please always keep the *Owner's Manual* in the vehicle. If you lend or resell the vehicle to someone else, be sure to hand the complete set of accompanying documents over to the new owner.

The following inspections must be carried out before driving:

- Check that all lamps work properly.
- Check that the fuel level is normal.
- Check that the coolant level is normal.
- Check that the brake fluid level is normal.
- Check that the windshield washer fluid level is normal.
- Check that the tire pressure is normal.
- Check that all windows are clear and have a good view.
- Check that no objects obstruct the movement of the driver's foot pedals.
- Adjust the seat, head restraint and rearview mirror according to your body height and shape.
- Use appropriate child safety seats to protect children and help them fasten the seat belts correctly.
- Fasten the seat belt correctly and remind all passengers in the vehicle to fasten the seat belts correctly.
- Check that the instrument, horn, wiper, reflector and steering mechanism work normally.
- Check that the surrounding environment is safe.



WARNING

When installing the driver's floor mat, please observe the following precautions:

- Do not overlap two or more floor mats.
- Do not make the bottom surface of the floor mat upward or back-to-front.
- Do not use floor mats that is incompatible with this model.



CAUTION

- Prevent yourself from being distracted by external factors during driving.
- Do not drive the vehicle when your response capability reduces due to effect of medicines, alcohol, or drugs.
- Strictly abide by traffic regulations.

3.1.2 Correct sitting posture of the driver and passengers

Correct sitting posture of the driver

The driver's sitting posture directly affects his/her fatigue level and driving safety. Before driving, the driver should:

- sit up straight and adjust the seat back to a suitable position so that your back fits completely the seat back.
- adjust the seat position so that all pedals can be operated effectively with slightly bent legs.
- correctly adjust the head restraint of the seat. => [See page 90](#)
- fasten the seat belt correctly. => [See page 15](#)
- adjust the steering wheel position. => [See page 34](#)

WARNING

- **Do not adjust the seat, head restraint or steering wheel during driving; otherwise, the vehicle may be out of control, leading to an accident.**

Correct sitting posture of the passengers

To guarantee the safety of the passengers and reduce the risk of casualties, the passengers should:

- sit up straight and adjust the head restraint of the seat correctly. => [See page 90](#)
- The front passenger should adjust the distance between the seat and the instrument panel according to his or her own needs.
- adjust the seat back to a suitable position so that the back fits completely the seat back (for front passenger).
- fasten the seat belt correctly. => [See page 15](#)
- place both feet on the floor.
- use appropriate child safety seat in accordance with applicable regulations for children. => [See page 25](#)

WARNING

- **If the front passenger is too close to the instrument panel, the SRS will not provide effective protection.**
- **When the vehicle is running, be sure to maintain a correct sitting posture and fasten the seat belt correctly, so as to avoid unexpected injuries in case of emergency braking or accidents.**
- **It is forbidden to install a child safety seat in the front passenger's seat.**

3. Instructions for safe operation

3.2 Seat belt

3.2.1 Why must you fasten the seat belt

Protection of the driver and passengers by seat belts



In the event of a collision, the seat belt will assist other safety systems in simultaneously absorbing the energy generated by the collision, further reducing the injuries suffered by the driver and passengers.

In the event of a collision, the seat belt will assist other safety systems in simultaneously absorbing the energy generated by the collision, further reducing the injuries suffered by the driver and passengers.



WARNING

- **Airbags cannot replace seat belts. Regardless of the availability of airbags, the seat belts should be fastened correctly.**

Consequences of not fastening the seat belt

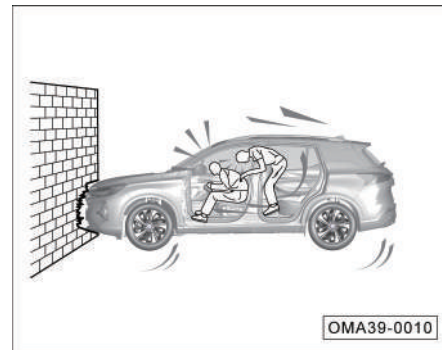

In the event of a collision, the driver or passenger who does not fasten the seat belt will be thrown forward due to inertia and thereby injured.

3. Instructions for safe operation

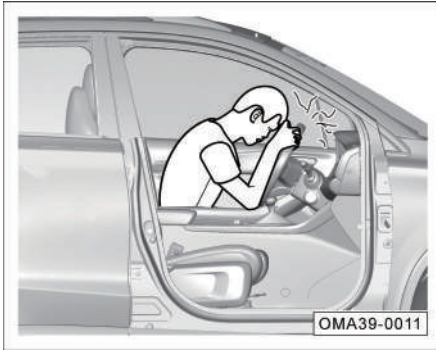

Even if the vehicle speed is very low, the force acting on the human body in the event of a collision is so great that the occupant cannot control his or her body with hands at all. In that case, the occupant who does not fasten the seat belt will be thrown forward, and injured once he or she collides with any interior objects.

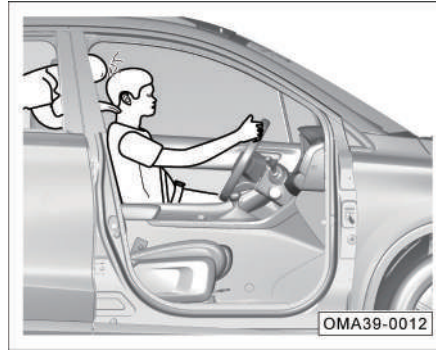

Rear passengers must also fasten the seat belts correctly, otherwise they will be thrown forward when an accident occurs. The rear passenger who does not fasten the seat belt will not only hurt himself or herself, but also endanger other passengers in the vehicles.

3.2.2 Seat belt

Seat belt indicator lamp

 :Driver's seat belt indicator lamp

 :Front passenger's seat belt indicator lamp

The following alarms will be triggered when the ENGINE START/STOP button is set to "ON" position:

- When the vehicle speed is lower than 20 km/h, if the driver or front passenger does not fasten the seat belt, the corresponding indicator lamp in the instrument cluster will flash for about 6 s and stay on, accompanied by an alarm message.
- When the vehicle speed is higher than or equal to 20 km/h, if the driver or front passenger does not fasten the seat belt, the corresponding indicator lamp in the instrument cluster will flash for about 20 s and stay on, accompanied by an alarm message and a continuous audible alarm.

3. Instructions for safe operation

CAUTION

- Before driving, please check whether there are any heavy objects on the front passenger's seat to avoid the system mistakenly determining that the seat is occupied and issuing a false alarm.
- If the alarm remains on after the seat belt is fastened correctly, it means that the SRS is failed. In that case, please go to the GAC Motor authorized shop for inspection in time.

WARNING

Never insert the buckle into the substitute of seat belt tongue to eliminate the seat belt alarm.

 : Rear seat belt indicator lamp*

If rear seat belt indicator lamp is on in white, it indicates that the seat belt is fastened, and if the indicator lamp is on in red, it indicates that the seat belt is fastened or the SRS is faulty. If the indicator lamp stays red after the seat belt is fastened correctly, it means that the SRS is failed. In that case, please go to the GAC Motor authorized shop for inspection in time.

The rear seat belt indicator lamp is on for 35s and then goes off in normal cases, and it will be lighted up under the following conditions:

- the rear seat belt is not fastened when the engine starts.
- the rear seat belt is not fastened when the rear door is opened/closed.
- the rear passenger fastens or unfastens the seat belt.

Seat belt pretensioner and load limiter



The seat belt pretensioner and load limiter can reduce the pressure of the seat belt on the chest of the driver or passenger and improve the protection performance.

- At the beginning of the vehicle collision, the seat belt pretensioner and load limiter can restrain the occupant and enable him or her to maintain a correct sitting posture to prevent the body from leaning forward.
- In the event of a severe collision where the triggering condition is reached, the seat belt pretensioner and load limiter will be triggered, driving the seat belt webbing to be quickly retracted and tensioned.

3. Instructions for safe operation

- When a collision occurs, the human body will move forward, and the seat belt pretensioner and load limiter will be activated at this time, so that the restraint force of the seat belt on the human body will be within a certain range, preventing the driver or passenger from being further injured due to excessive force. And at the same time, the seat belt pretensioner and load limiter will coordinate with the airbag to achieve a better safety protection performance.

i NOTE

- When the seat belt pretensioner and load limiter is activated, a little harmless smoke together with a sound will be produced, which is normal.
- If the seat belt pretensioner and load limiter is deployed, it cannot be used any more, and the SRS indicator lamp  will stay on. In that case, please contact the GAC Motor authorized shop for replacement.

Adjusting the shoulder belt height



- Moving up: Grasp the guide and move it up to adjust the shoulder belt to the appropriate height.
- Moving down: Press the guide to unlock the switch ① and move it down to adjust the shoulder belt to the appropriate height.
- After the adjustment, check whether the guide is firmly locked.

Buckling the seat belt

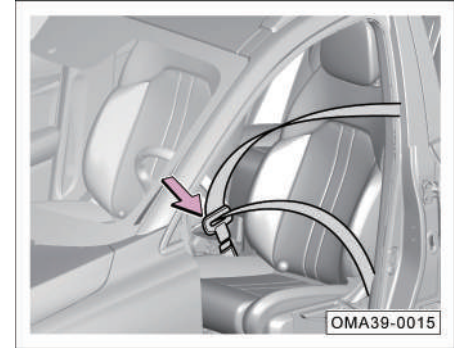

- Keep a correct sitting posture. => [See page 11](#)
- Pull out the seat belt slowly at a uniform speed, insert the lock tongue into the corresponding buckle until a click sound is heard.
- Pull the seat belt and confirm that the lock tongue is properly locked.

3. Instructions for safe operation

Unbuckling the seat belt

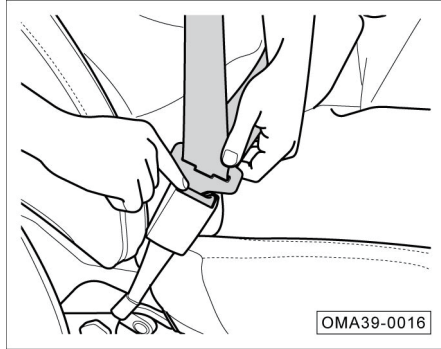

- Press the red button of the buckle. Then the lock tongue will pop out automatically.
- Grasp the seat belt to allow it to retract slowly.

Correct fastening of seat belt required for pregnant women



Method of correct fastening of the seat belt for a pregnant woman:

- Adjust the seat and head restraint to the proper position.
- Grasp the lock tongue, slowly pull the seat belt over the shoulder, and ensure that the lap belt is as low as possible and not pressed against the abdomen.
- Insert the lock tongue into the corresponding buckle until a buckling sound is heard.
- Pull up the shoulder belt parallel to the upper body to tension the lap belt and ensure that the lock tongue is properly buckled.

WARNING

To reduce the risk of injury during emergency braking or accidents, please observe the following precautions:

- Before driving, make sure that all occupants have properly fastened the seat belts.
- Each seat belt is for one person only. Do not share a seat belt with other persons (including children).
- Do not recline the front seat back excessively for comfort.
- Do not put the shoulder belt under or behind your arm.
- Be sure to insert the lock tongue into the buckle of corresponding side instead of the buckle of other side.
- Never unbuckle the seat belt before the vehicle comes to a complete stop.

3.3 Supplemental restraint system (SRS)

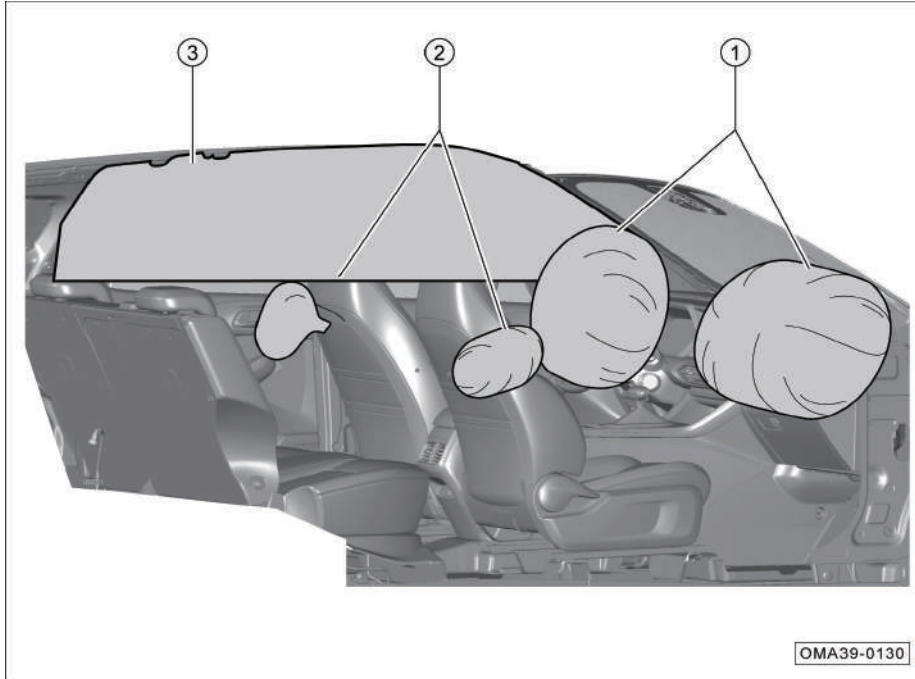

Depending on vehicle configurations, the deployment positions of the SRS are as shown below:

- ① Front seat frontal airbags.
- ② Front seat side airbag*.
- ③ Side curtain airbag*.

i NOTE

The airbag will produce a little harmless smoke when deployed, which is normal.

3. Instructions for safe operation

Supplemental restraint system (SRS) indicator lamp

After the ignition switch is switched to “ON” position, the indicator lamp  will be on for a few seconds and go out after the system completes self-test.

A system fault is indicated when the indicator lamp  is in the following conditions:

1. After the ignition switch is switched to “ON” position, the indicator lamp does not come on.
2. After the ignition switch is switched to “ON” position, the indicator lamp does not go out after the system completes self-test.
3. After the ignition switch is switched to “ON” position, the indicator lamp goes out but then comes on again.
4. The indicator lamp comes on or flashes while the vehicle is running.

WARNING

- **Never attempt to repair, adjust or modify the airbag.**
- **The airbag can be deployed once only, and thus, if it is deployed in the event of an accident, please contact the GAC Motor authorized shop for replacement.**
- **When the SRS is faulty, please contact the GAC Motor authorized shop for inspection. Otherwise, the system might not trigger or abnormally trigger the airbag in the event of a vehicle collision.**

Front seat frontal airbag



The driver's frontal airbag is installed inside the steering wheel (as indicated by the shaded area), where “SRS AIRBAG” is the airbag sign.

3. Instructions for safe operation

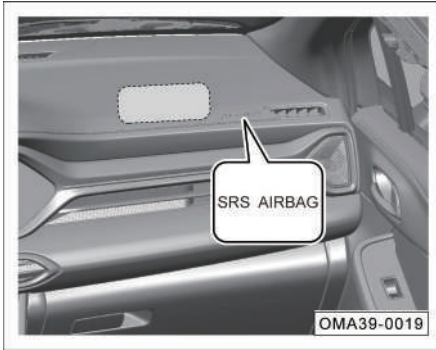

The front passenger's frontal airbag is installed inside the instrument panel (as indicated by the dotted dash) marked with "SRS AIRBAG".

In the event of a frontal collision which is severe enough to meet the triggering condition of frontal airbag, the frontal airbags will be triggered by the system and deploy rapidly to assist the seat belt in protecting the driver and front passenger.

In certain collision accidents, the system may simultaneously trigger other airbags.

WARNING

Do not attach or place any decorative objects on the surface of instrument panel, because when the vehicle is running or the airbag deploys, these objects will fall, be knocked over and roll around in the vehicle, affecting the driver and hurting the passengers in the vehicle.

The frontal airbags might not be triggered under any one of the following:

- when the ignition switch is in "ACC" or "OFF" position.
- Minor frontal collision.
- Side collision.
- Rear collision.
- Rollover.
- Other special circumstances.

NOTE

The word "minor" implies the severity of collision sensed by the vehicle control unit and has nothing to do with the damage of the vehicle.

3. Instructions for safe operation

Front seat side airbag*



The front seat side airbags are installed in the outboard sides of the driver's seat back and the front passenger's seat back respectively (as indicated by the dotted dash) marked with "SRS AIRBAG".

In the event of a side collision which is severe enough to meet the triggering condition of frontal airbag, the side airbags will be triggered by the system and deploy rapidly to assist the seat belt in protecting the driver and front passenger.

In certain collision accidents, the system may simultaneously trigger other airbags.

The front seat side airbags might not be triggered under any one of the following:

- when the ignition switch is in "ACC" or "OFF" position.
- 100% frontal collision.
- Minor side collision.
- Rear collision.
- Other special circumstances.

i NOTE

The word "minor" implies the severity of collision sensed by the vehicle control unit and has nothing to do with the damage of the vehicle.

3. Instructions for safe operation



WARNING

- **Observe the instructions on the warning label pasted on the side of the door. Do not lean your body against the door side equipped with side airbags during driving.**
- **Do not cover the side airbags with seat covers or other objects; otherwise, the side airbags will not be deployed to protect the occupants when an accident occurs.**

Side curtain airbag *

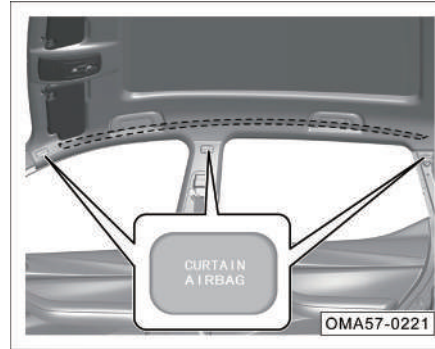

Side curtain airbags are installed in the left and right sides of the roof respectively (as indicated by the dotted dash) marked with “CURTAIN AIRBAG”.

In the event of a severe side collision, the side curtain airbags on the side where the vehicle collides will be triggered by the system and deploy rapidly to assist the seat belts in protecting the driver and passengers.

In certain collision accidents, the system may simultaneously trigger other airbags.

The side curtain airbags might not be triggered under any one of the following:

- when the ignition switch is in “ACC” or “OFF” position.
- 100% frontal collision.
- Minor side collision.
- Rear collision.
- Other special circumstances.

NOTE

The word “minor” implies the severity of collision sensed by the vehicle control unit and has nothing to do with the damage of the vehicle.

3. Instructions for safe operation

3.3.1 Cases where the airbags might deploy

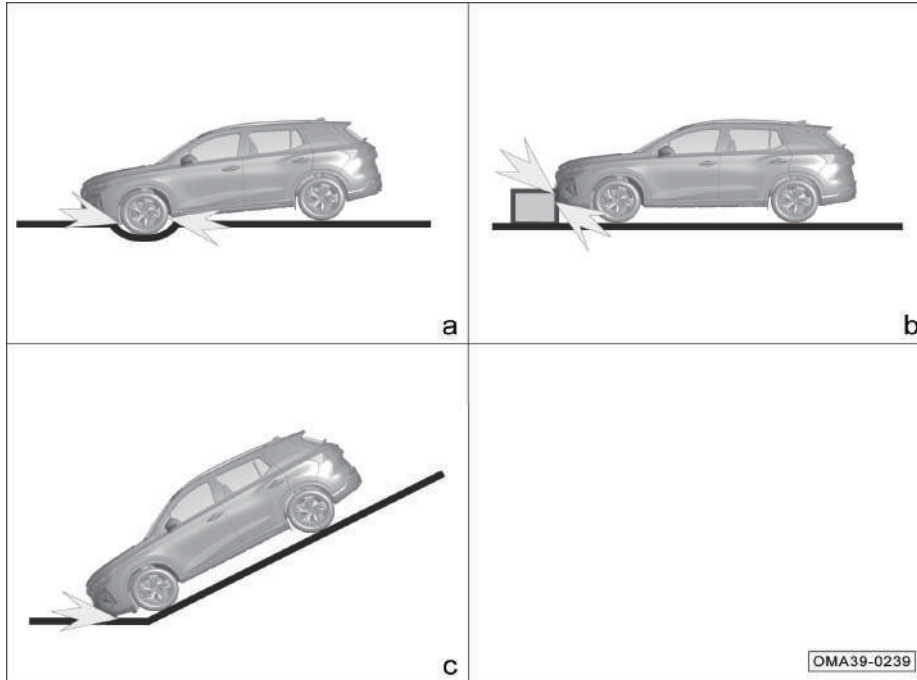

- nose-down to the ground when the vehicle crosses a deep groove.
- collision with roadside protrusions, curbs, etc.
- nose-down to the ground when the vehicle runs down a steep slope.

3. Instructions for safe operation

3.3.2 Cases where the airbags might not deploy

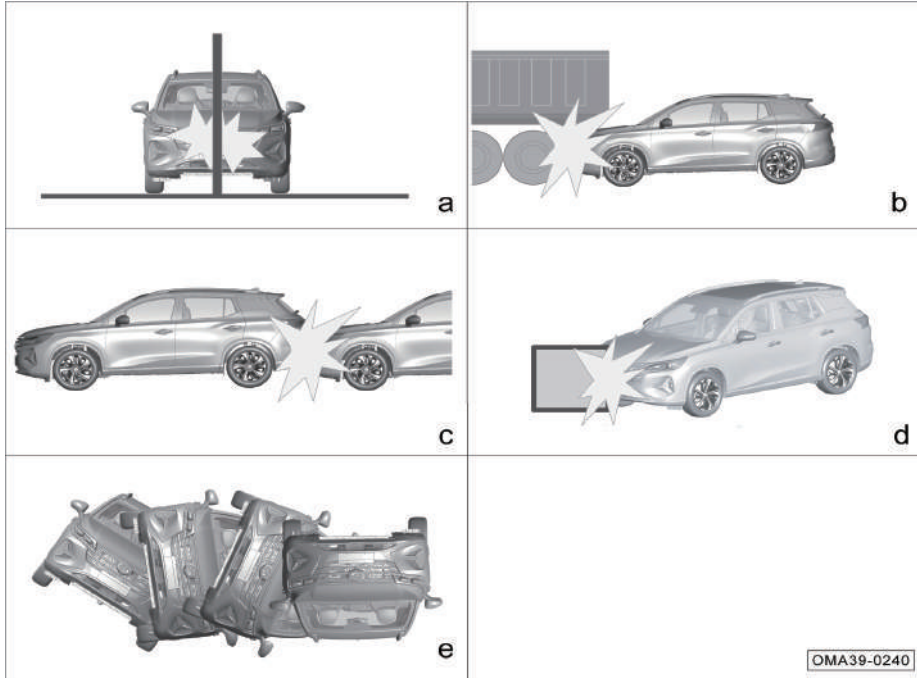

- collision with concrete pillars, trees or other elongated objects.
- rear-end collision with the lower rear end of large truck.
- rear-end collision by other vehicles.
- collision (other than frontal collision) with a wall or another vehicle, other than frontal collision.
- Rollover or tilting.

3. Instructions for safe operation

3.4 Safe ride of children

3.4.1 General

The child must sit in a rear seat, and a suitable child safety seat should be selected according to the body size of the child.



Warning labels are pasted on the front and back of the right sun visor to remind the front passenger of the danger of frontal airbag. Be sure to read and follow the instructions on the labels.

⚠ WARNING

- Do not install any rear-facing child restraint system on seats with frontal airbags!
- Even if the child has been put in a child safety seat, do not let the head or any part of the body rest on the door area (the deployment area of the front seat side airbag or side curtain airbag *); otherwise, the impact force of the deployed front seat side airbag or side curtain airbag * can cause serious injury or even death of the child.
- Do not let children stand or kneel on the seat.
- Do not allow children to operate devices that may cause pinch to themselves (such as power window, sunroof, etc.).

⚠ WARNING

- Never leave children alone in the vehicle!
- Never hold infants or toddlers on your knees!
- Seat belts are not suitable for infants and toddlers as they can cause injuries in the event of an accident.
- Ensure that in the event of a collision or emergency braking, children are less likely to be injured by hitting any hard objects in the vehicle.
- Lock the child safety lock of the door on the side where the child sits.

3. Instructions for safe operation

3.4.2 Child safety seat



OMA39-0131

Classification of child safety seats (for reference only):

a. Group 0/0+ child safety seat

- Suitable for infants weighing less than 13 kg.

b. Group I child safety seats:

- Suitable for toddlers weighing between 9 kg and 18 kg.

c. Group II child safety seats:

- Suitable for children weighing between 15 kg and 25 kg.

d. Group III child safety seats:

- Suitable for children weighing between 22kg and 36kg.

3. Instructions for safe operation

3.4.3 Information about child safety seat

Information about the applicability of different seating positions for child restraint systems:

Weight group	Mounting position		
	Front passenger seat	Outboard rear seats	Rear middle seat
Group 0: <10 kg	X	U	X
Group 0+: <13 kg	X	U	X
Group I: 9~18 kg	X	U/UF	X
Group II: 15~25 kg	X	UF	X
Group III: 22~36 kg	X	UF	X

Note: The uppercase letters in the table are defined as follows:

U = Suitable for all "general" child safety seats allowed for this weight group.

UF = Suitable for all forward-facing "general" child safety seats allowed for this weight group.

X = Not suitable for the child safety seats for this weight group.

For some child safety seats, a size class is specified. Be sure to check the size class according to the manufacturer's instructions, packaging, and child safety seat label. For guidance on proper installation, please refer to the instruction of the child safety seat.

3. Instructions for safe operation

Information about the applicability of different seating positions for child restraint systems:

Weight group	Size class	Achorage module	Mounting position		
			Front passenger seat	Outboard rear seats	Rear middle seat
Carry-cot	F	ISO/L1	X	X	X
Group 0: <10 kg	G	ISO/L2	X	X	X
	E	ISO/R1	X	IL	X
Group 0+: <13 kg	E	ISO/R1	X	IL	X
	D	ISO/R2	X	IL	X
	C	ISO/R3	X	IL	X
Group I: 9~18 kg	D	ISO/R2	X	IL	X
	C	ISO/R3	X	IL	X
	B	ISO/F2	X	IUF	X
	B1	ISO/F2X	X	IL	X
	A	ISO/F3	X	IUF	X
Group II: 15~25 kg	-	-	X	-	X
Group III: 22~36 kg	-	-	X	-	X

Note: The uppercase letters in the table are defined as follows:

IUF - Suitable for “forward-facing” general ISOFIX child safety seats for this weight group that are fixed with top tether.

IL - Suitable for the listed special ISOFIX child restraint systems, which may be for special vehicles, or of restricted or semi-general categories.

X - Not suitable for the child safety seats for this weight group.

For some child safety seats, a size class is specified. Be sure to check the size class according to the manufacturer’s instructions, packaging, and child safety seat label. For guidance on proper installation, please refer to the instruction of the child safety seat.

3. Instructions for safe operation

3.4.4 Installing the child safety seat correctly

The child safety seat is installed by three-point seat belt, ISOFIX system, or LATCH system.

To ensure a better protection effect and prevent the headrest from affecting the performance of the child safety seat during use, it is recommended to remove the headrest of the seat on which the child safety seat is installed.

i NOTE

During the actual installation of the child safety seat, be sure to refer to the instruction of the child safety seat for correct installation.

Installation of child safety seat by three-point seat belt



1. Place the child safety seat on the rear seat.
2. Pass the seat belt through the child safety seat and fully insert the tongue into the buckle until a click is heard.

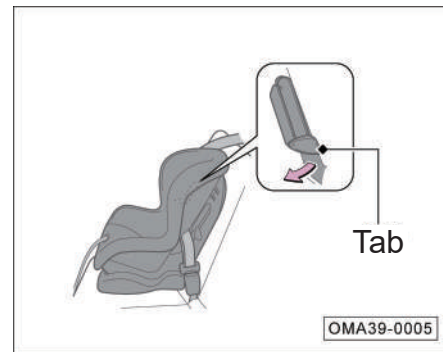

3. Push the tab down. Then, pass the shoulder belt through the slit on the side of the child safety seat.

3. Instructions for safe operation

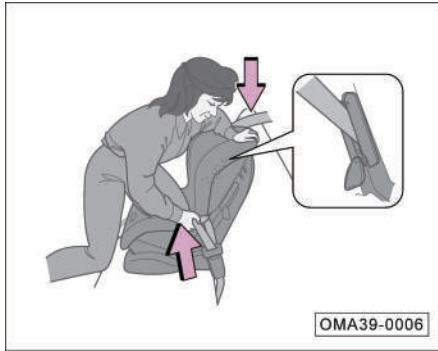

4. Grasp the shoulder belt near the buckle and pull it up to tension the lap belt. At this time, press the child safety seat with your own weight and push it into the vehicle seat.

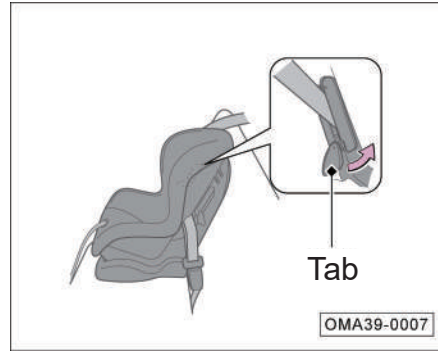

5. Place the seat belt correctly and push the tab up. Make sure the seat belt is not twisted. When pushing the tab up, pull upward the upper part of the shoulder belt to tension the belt.

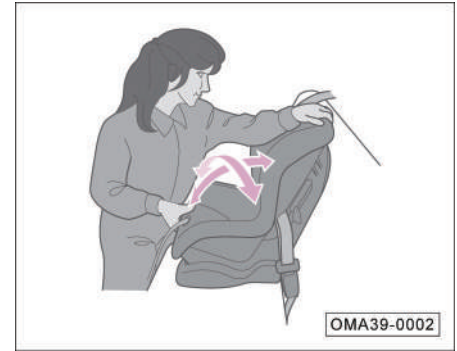

6. Shake the child safety seat back and forth, left and right to make sure it is firmly fixed.
7. Make sure that all unused seat belts in the reach of the children are locked.

3. Instructions for safe operation

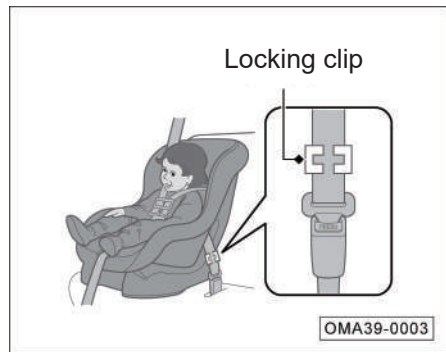

If no means are provided on the child safety seat for securing the seat belt, please install a locking clip on the seat belt.

- After the above steps 1 and 2, pull up the shoulder belt and make sure the lap belt is tensioned.
- Firmly grasp the seat belt near the locking tab. Pinch the two parts of the seat belt together so that they do not slip out of the locking tab, and then unlock the seat belt buckle.

Install the locking clip as shown. Place the buckle as close as possible to the locking tab and insert the locking tab into the locking clip. Go to steps 6 and 7.

Installing ISOFIX or LATCH system

The rear seats of this vehicle are equipped with the LATCH system, and thus suitable for the LATCH or ISOFIX child safety seats. The installation instructions of the LATCH child safety seat are as follows.

⚠ WARNING

- **The child safety seat anchorages equipped in the vehicle can be used to fix the child safety seat only.**
- **Never connect straps, hard and sharp objects or any other objects other than child safety seats to the anchorages; otherwise children may be endangered in the event of an accident.**

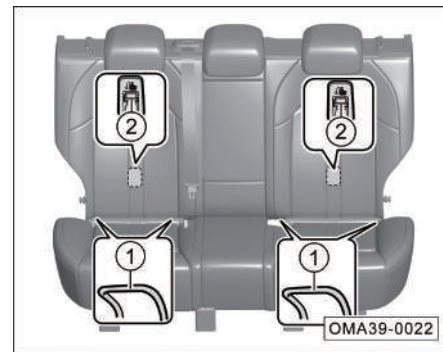

i NOTE

The lower anchorage ① of the rear seat is concealed in the gap between the seat back and cushion; the upper anchorage ② is at the rear of the seat back.

3. Instructions for safe operation

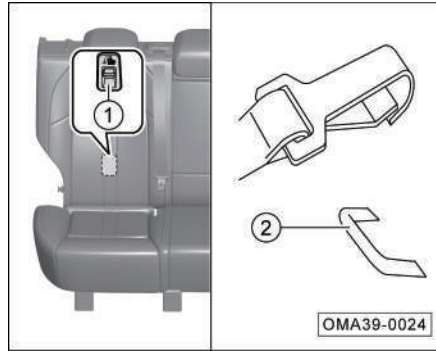
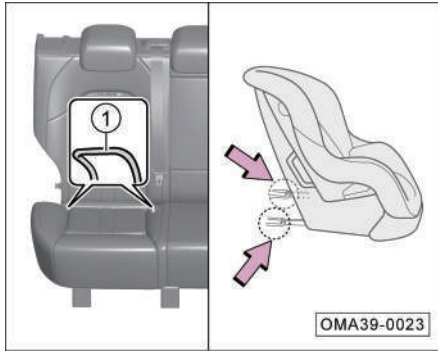

1. Put the child safety seat on the seat, find the lower anchorage ①, and insert the lower guide grooves of the child safety seat as arrowed into the lower anchorage ① until a click is heard.
2. Pass the strap through the top of the seat back, open the protective cover of the upper anchorage ②, and catch the upper anchorage ② with the strap hook to ensure that the strap is not twisted.
3. Tension the strap. Shake the child safety seat back and forth, left and right to make sure it is firmly fixed.

3. Instructions for safe operation

3.5 Exhaust gas hazard

Carbon monoxide gas

The exhaust gas emitted by the engine contains the toxic carbon monoxide gas. Please use the car correctly to prevent the carbon monoxide gas from entering the vehicle.

Please contact the GAC Motor authorized shop to check whether the exhaust system is normal in the following cases:

- The exhaust system makes abnormal noises.
- The exhaust color is abnormal (e.g. blue smoke).

If the engine is idling during parking, please open all the windows and turn on the HVAC system:

1. Select the fresh air mode.
2. Select  mode.
3. Set the fan speed to the maximum.

WARNING

- **Carbon monoxide gas is toxic, and inhaling a great quantity of it will cause loss of consciousness and even death.**
- **When the engine is started for a long time in a confined space (such as a garage, etc.), carbon monoxide will quickly accumulate, resulting in excessive carbon monoxide in the vehicle. After starting the engine, drive the vehicle away from the confined space immediately.**

3.6 Safety label

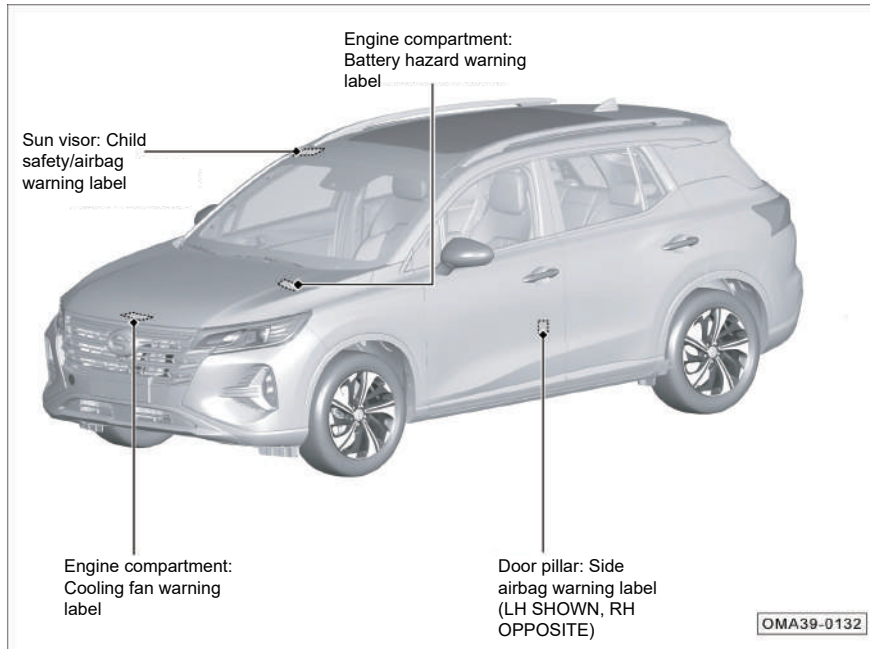

The labels are located as shown to remind you of the potential danger that can cause serious injury or death. Please read these labels carefully.

If the label comes off or is difficult to read, please go to the GAC Motor authorized shop in time for replacement.

i NOTE

In case of any discrepancy in the illustrated location or quantity of the labels, the actual vehicle shall prevail.

4. Operation of systems and equipment

4.1 Driving space

4.1.1 Steering wheel

Adjusting the steering wheel



- Adjust the driver's seat to a suitable position, so that the distance between the steering wheel and your chest is not less than 25 cm.

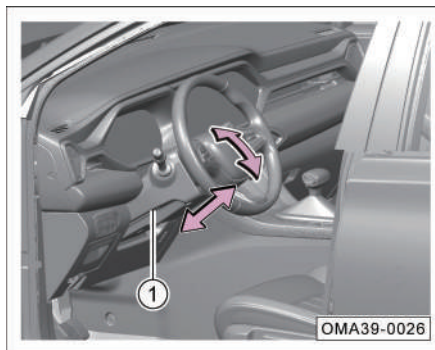



- Pull up the locking handle ① to unlock the steering wheel.
- Adjust the steering wheel up and down, and fore and aft, to the appropriate position, so that it directly faces to your chest and you can see the instrument cluster and all indicator lamps.
- Press down the locking handle ① to lock the steering wheel and make sure it is firmly locked.

CAUTION

- During driving, the driver's hands should always grasp the outer ring of the steering wheel (9 o'clock and 3 o'clock positions).
- After adjustment, the steering wheel must be locked to prevent shifting while the vehicle is running.
- Only when the vehicle is stopped can the steering wheel be adjusted to avoid traffic accidents.
- To ensure safety, the steering wheel should face your chest, otherwise the airbag cannot provide effective protection in the event of an accident.

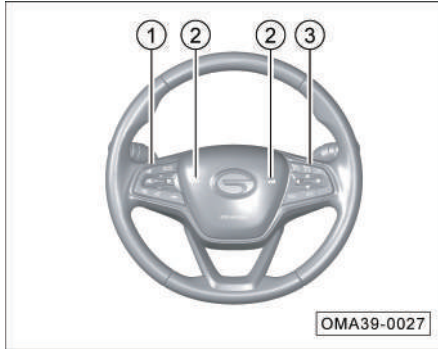
Buttons on steering wheel



1. AV system control button => [See page 117](#)
2. Horn button: Press  button to sound the horn; release the button to stop sounding the horn.

WARNING

Do not press and hold  button for a long time; otherwise the horn is highly prone to be damaged.

3. The right buttons include the control buttons of the instrument cluster display and the cruise control buttons:
 - Control buttons of the instrument cluster display:
 - Driving information => [See page 41](#)
 - Menu setting => [See page 42](#)
 - Alarm information => [See page 43](#)
 - Cruise control buttons:
 - Cruise control button*. => [See page 153](#)
 - ACC button*. => [See page 155](#)

NOTE

There may be differences depending on the configuration of the model. Please refer to the actual vehicle configurations.

4. Operation of systems and equipment

4.1.2 Instrument cluster

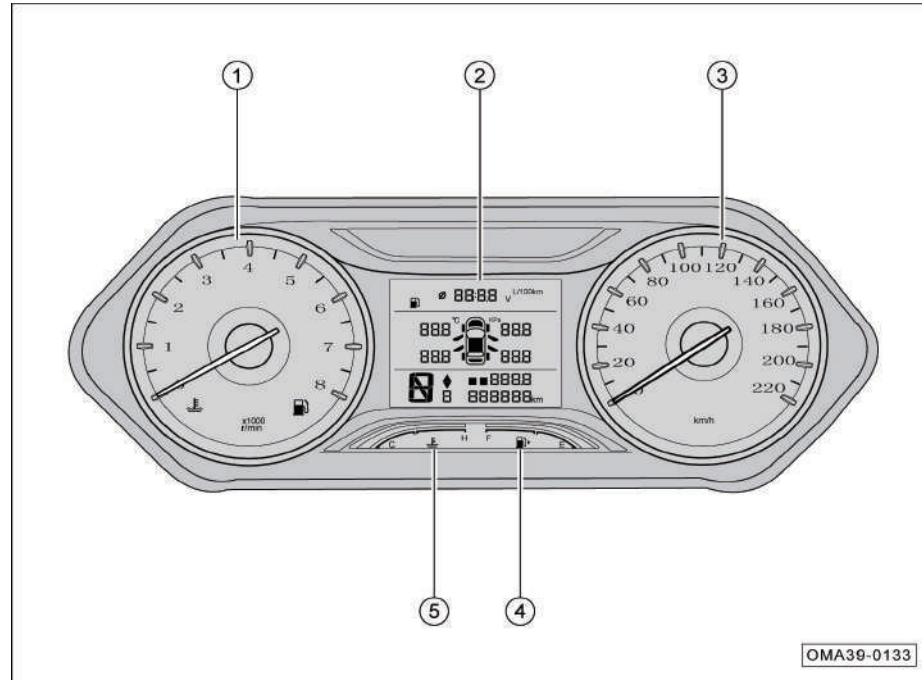

Instrument cluster (3.5-inch segment display)*

- ① Tachometer
- ② Instrument cluster display
- ③ Speedometer
- ④ Fuel gauge
- ⑤ Engine coolant temperature gauge

4. Operation of systems and equipment

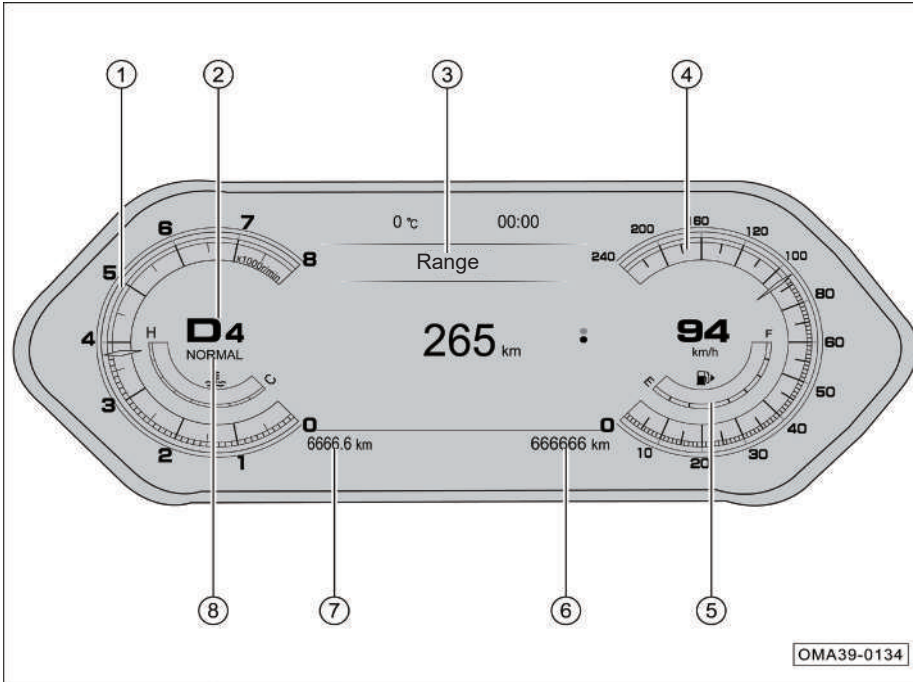

Instrument cluster with 12.3-inch display (classic theme)*

- ① Tachometer
- ② Gear display
- ③ Instrument cluster display
- ④ Speedometer
- ⑤ Fuel gauge
- ⑥ Odometer
- ⑦ Trip meter
- ⑧ Engine coolant temperature gauge
- ⑨ Driving mode

i NOTE

The instrument cluster shows different colors corresponding to the switched driving modes.

4. Operation of systems and equipment

Instrument cluster with 12.3-inch display (technology theme)*

- ① Tachometer
- ② Instrument cluster display
- ③ Speedometer
- ④ Fuel gauge
- ⑤ Odometer
- ⑥ Driving mode
- ⑦ Gear display
- ⑧ Trip meter
- ⑨ Engine coolant temperature gauge

i NOTE

The instrument cluster shows different colors corresponding to the switched driving modes.

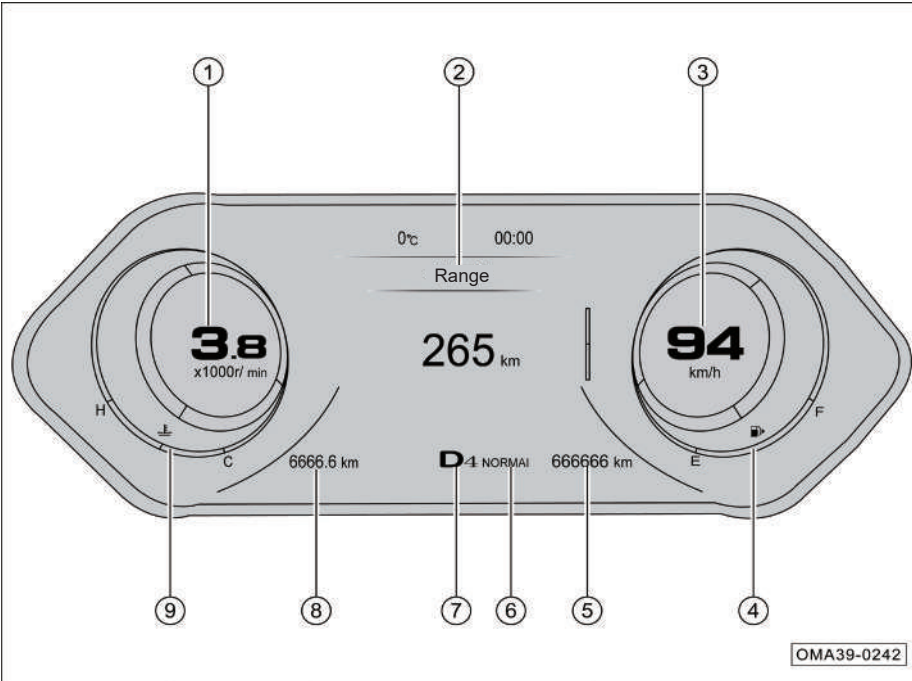

4. Operation of systems and equipment

Tachometer

The tachometer is used to indicate the current engine speed, in 1,000 r/min, with the indication range of 0~8000 r/min.

NOTE

6000~8000 r/min represents the high load area of the engine, where fuel shut-off and loss of power will occur due to self-protection of the engine. Therefore, the engine speed must not reach this area.

Instrument cluster display

Displayed information includes driving information => [See page 41](#), menu setting => [See page 42](#), navigation information* => [See page <?>](#), and alarm information => [See page 43](#)

CAUTION

If the instrument cluster display is abnormal, stop the vehicle immediately for the sake of safety, and contact the GAC Motor authorized shop for inspection.

Engine coolant temperature gauge

The engine coolant temperature gauge (water temperature gauge) is used to indicate the current temperature of the engine coolant.

- The indication range covers C~H, where, "C" means low temperature and "H" means high temperature.

After the engine is started, the corresponding scale divisions of the coolant temperature gauge will be illuminated according to different temperatures, and the engine operating temperature will vary depending on the ambient temperature and engine load.

- Conditions where the gauge indicates high coolant temperature: prolonged climbing in hot weather; deceleration or stop after driving at a high speed; in areas with heavy traffic, where the HVAC system is turned on and the engine idles for a long time; towing, etc.
- Conditions where the gauge indicates low coolant temperature: insufficient warm-up after cold start in cold weather; running with maximum heating in cold weather, etc.

Fuel gauge

The fuel gauge is used to indicate the current amount of fuel remaining in the fuel tank.

- The indication range is E~F, where "E" means the fuel tank is empty, and "F" means the fuel tank is full.
- The corresponding scale divisions on the dial of the gauge lights up according to the amount of remaining fuel in the fuel tank. When no division or only the first division lights up, it means that the fuel in the fuel tank is insufficient. In that case, the fuel level indicator lamp  will also light up, accompanied by the text prompt "Low fuel level", reminding the driver that there is not enough fuel and fuel should be added as soon as possible.

Gear display*

- The current gear information of the vehicle such as "P", "R", "N" or "D" is displayed according to the received signal.

4. Operation of systems and equipment

Driving mode*

- The current driving mode of the vehicle is displayed according to the received signal.

Odometer

- The odometer indicates the currently traveled distance of the vehicle in the driving information screen.
- The indication range is 0 km ~ 999999km.

Speedometer

The speedometer is used to indicate the current speed of the vehicle in km/h, with the indication range of 0~240 km/h.

 **CAUTION**

For driving safety, please strictly abide by the traffic rules, and never speed at will.

4. Operation of systems and equipment

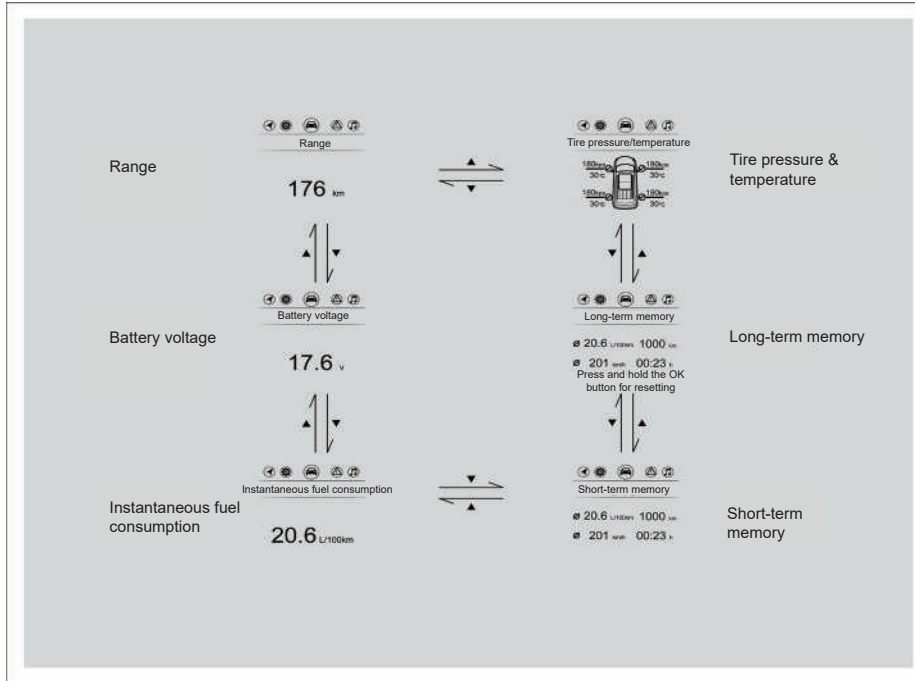

Driving information

When the ignition switch is at "ON" position, press ◀ or ▶ button on the right of the steering wheel to switch to the driving information screen, and then turn the button upwards or downwards to switch the display information screens.

i NOTE

- When no valid information is received, the driving information screen will not display valid data.
- The data on the long-term memory screen can be reset by pressing and holding the OK button.

4. Operation of systems and equipment

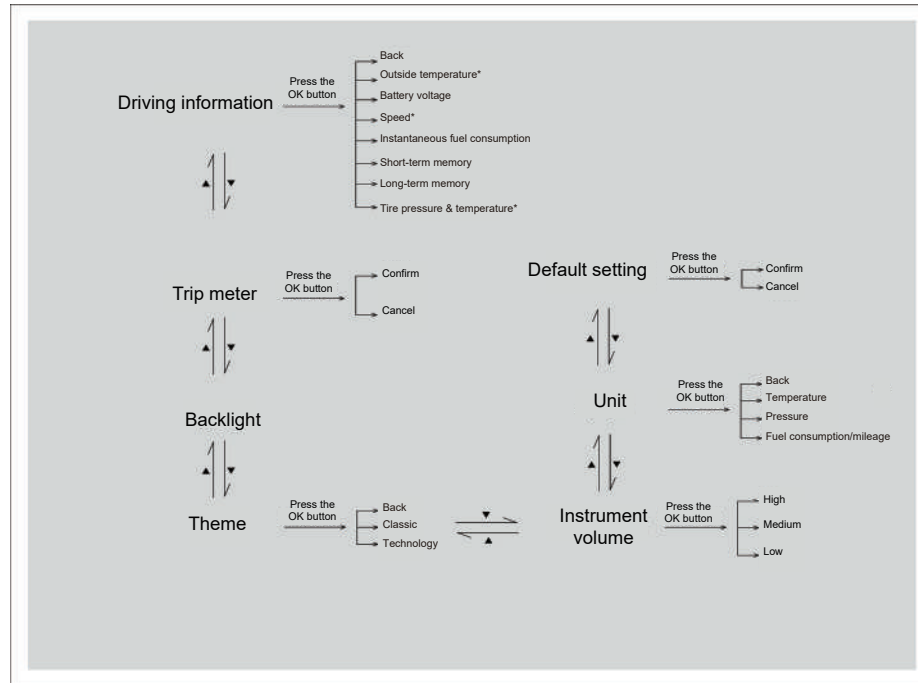

Menu setting

When the vehicle speed is zero with the ignition switch set to “ON” position, press the ◀ or ▶ button on the right of the steering wheel to switch to the menu setting screen, where you can turn the button upward or downward to move the cursor for selection, press the OK button to enter the sub-menu, and then press the OK button for selection, confirmation or cancellation.

i NOTE

When the vehicle speed is not zero, the warning message “Safety Prompt: Set After Stop” will be displayed; if the warning message appears for more than 5 s, the instrument cluster will automatically switch to the driving information screen.

4. Operation of systems and equipment

Alarm message



On the alarm message screen, the current state of the vehicle is displayed in the form of texts, pictures or others. The driver should always pay attention to checking for alarm message.

- If the vehicle is in good condition and there is no alarm message, the alarm message screen will display "No message".

- When the vehicle is abnormal with the ignition switch set to "ON" position, the instrument cluster will give priority to the display of the alarm message, where you can press the OK button to confirm the alarm message, after which the system will go back to the previous screen. If there is no operation after 5 s, the alarm message will be displayed again.

i NOTE

When multiple alarm messages exist, be sure to read and confirm them one by one before returning to the previous screen.

Call information*

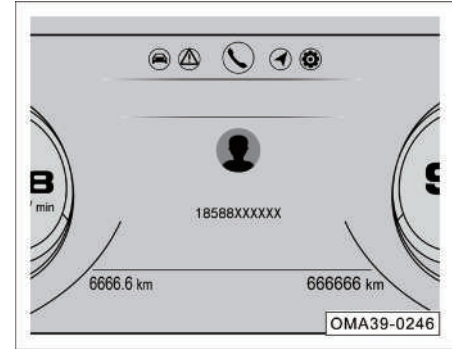

- When the AV system is connected to the Bluetooth of the mobile phone and there is an incoming call, the call information screen will display incoming call, calling, outgoing call, call end, and missed call.
- When the E-CALL is used, the call information screen will display E-CALL status.

4. Operation of systems and equipment

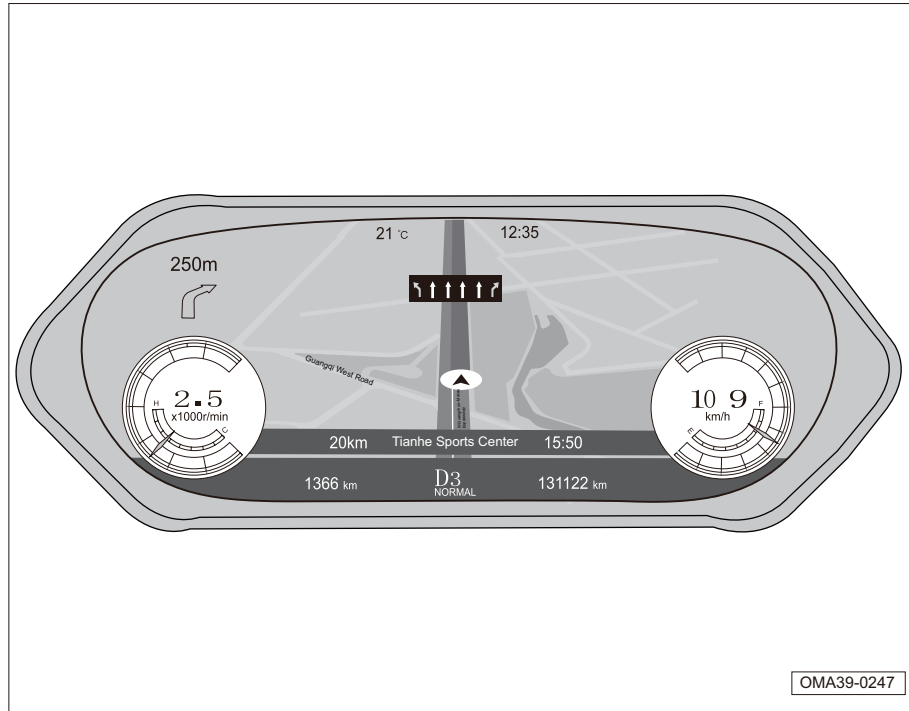









Navigation information*

When the ignition switch is at “ON” position, press the ◀ or ▶ button on the right of the steering wheel to switch to the navigation information screen.











- When the navigation function of the AV system is activated, the corresponding navigation information will be displayed according to the navigation function status of the AV system.

4. Operation of systems and equipment









4.1.3 Indicator lamp

S/N	Symbol	Meaning	Color	Trigger condition
1		Door ajar indicator lamp	Red	If the red indicator lamp comes on, it indicates that the door is ajar.
2		Charging system warning lamp	Red	This warning lamp will come on when the engine is not started with the ignition switch set to "ON" position, and will go out after the engine is started. If this warning lamp comes on after the engine is started, it indicates that the charging system is faulty.
3		MIL	Yellow	If there is no fault, this indicator lamp will come on and stay on for a few seconds when the engine is not started with the ignition switch set to "ON" position, and then will go out after the system self-test. If this indicator lamp comes on after the engine is started, it indicates that the engine system is faulty.
4		Low oil pressure warning lamp	Red	This warning lamp will come on when the engine is not started with the ignition switch set to "ON" position, and will go out after the engine is started. If this warning lamp comes on after the engine is started, it indicates that the engine oil pressure is low.
5		Emission fault indicator lamp	Yellow	This indicator lamp will come on when the engine is not started with the ignition switch set to "ON" position, and will go out after the engine is started. If this indicator lamp comes on after the engine is started, it indicates that the exhaust system is faulty.
6		Left turn signal indicator lamp and hazard warning lamp	Green	When the left turn signal indicator lamp flashes alone, it indicates that the left turn signal lamp of the vehicle is on. When the hazard warning lamp switch is pressed, the left/right turn signal indicator lamps and all turn signal lamps will flash simultaneously.
7		High engine coolant temperature indicator lamp	Red	If the red indicator lamp comes on, it indicates that the engine coolant temperature is too high.
8		Supplemental restraint system (SRS) indicator lamp	Red	If the red indicator lamp comes on, it indicates that the SRS system is faulty.











4. Operation of systems and equipment

S/N	Symbol	Meaning	Color	Trigger condition
9		Low fuel level indicator lamp	Yellow	If the yellow indicator lamp flashes, it indicates that the fuel level of the fuel tank is low.
				If the yellow indicator lamp comes on, it indicates that the fuel pump may be faulty.
10		Right turn signal indicator lamp and hazard warning lamp	Green	If the right turn signal indicator lamp flashes alone, it indicates that the right turn signal lamp of the vehicle is on.
				When the hazard warning lamp switch is pressed, the left/right turn signal indicator lamps and all turn signal lamps will flash simultaneously.
11		Electric park brake (EPB) status indicator lamp	Red	If the red indicator lamp comes on, it indicates that the EPB is applied.
			Green	If the green indicator lamp comes on, it indicates that the EPB is activated.
12		Electric park brake (EPB) fault indicator lamp	Yellow	If the yellow indicator lamp comes on, it indicates that the EPB system is faulty.
				If the yellow indicator lamp flashes, it indicates that the EPB is in the service mode.
13		Parking brake and brake system indicator lamp	Red	If the red indicator lamp comes on, it indicates that the brake fluid level is too low or the electronic brake force distribution (EBD) system is faulty.
14		Electronic stability program (ESP) indicator lamp	Yellow	If the yellow indicator lamp comes on, it indicates that the ESP is faulty.
				If the yellow indicator lamp flashes, it indicates that the ESP is working.
15		Electronic stability program off (ESP OFF) indicator lamp	Yellow	If the yellow indicator lamp comes on, it indicates that the ESP is off.
16		Anti-lock braking system (ABS) indicator lamp	Yellow	If the yellow indicator lamp comes on, it indicates that the ABS is faulty.
17		Transmission fault indicator lamp	Yellow	If the yellow indicator lamp comes on, it indicates that the automatic transmission system is faulty.
				If the yellow indicator lamp flashes, it indicates that the ATF temperature is high.
18		Tire pressure monitoring system (TPMS) indicator lamp	Yellow	If the yellow indicator lamp comes on, it indicates that the TPMS is faulty or any tire is abnormal.
19		Electric power steering (EPS) indicator lamp	Red	If the red indicator lamp comes on, it indicates that the EPS system is faulty.

4. Operation of systems and equipment

S/N	Symbol	Meaning	Color	Trigger condition
20		Cruise control indicator lamp *	White	If the white indicator lamp comes on, it indicates that the cruise control is in the ready state.
			Green	If the green indicator lamp comes on, it indicates that the cruise control is activated.
21		ACC indicator lamp (no vehicle ahead) *	White	If the white indicator lamp comes on, it indicates that the ACC is in the ready state, and there is no target vehicle ahead.
			Green	If the green indicator lamp comes on, it indicates that the ACC is working, and there is no target vehicle ahead.
22		ACC indicator lamp (a vehicle ahead) *	White	If the white indicator lamp comes on, it indicates that the ACC is in the ready state, and there is a target vehicle ahead.
			Green	If the green indicator lamp comes on, it indicates that the ACC is working, and there is a target vehicle ahead.
23		ACC fault indicator lamp *	Yellow	If the yellow indicator lamp comes on, it indicates that the ACC is faulty.
24		LDW status indicator lamp*	White	If the white indicator lamp comes on, it indicates that the LDW system is activated.
			Yellow	If the yellow indicator lamp comes on, it indicates that the LDW system intervenes with the steering wheel for deviation correction.
			Red	If the red indicator lamp comes on, it indicates that the LDW system is faulty. In that case, please go to the GAC Motor authorized shop for inspection in time.
			Green	If the green indicator lamp comes on, it indicates that the LDW system is working normally.
25		FCW status indicator lamp *	Green	If the green indicator lamp comes on, it indicates that the FCW system is activated.
			Red	If the red indicator lamp comes on, it indicates that the FCW system is faulty. In that case, please go to the GAC Motor authorized shop for inspection in time. If the red indicator lamp flashes, it indicates that the FCW system is being triggered.
28		Front passenger's seat belt indicator lamp	Red	If the red indicator lamp comes on, it indicates that the front passenger's seat belt is not fastened or the system is faulty.
29		Driver's seat belt indicator lamp	Red	If the red indicator lamp comes on, it indicates that the driver's seat belt is not fastened or the seat belt system is faulty.

4. Operation of systems and equipment

S/N	Symbol	Meaning	Color	Trigger condition
30		Rear seat belt indicator lamp *	White	If the white indicator lamp comes on, it indicates that the rear seat belt is fastened.
			Red	If the red indicator lamp comes on, it indicates that the rear seat belt is not fastened or the seat belt system is faulty.
31		Intelligent high beam indicator lamp *	White	If the white indicator lamp comes on, it indicates that the intelligent high beam is activated.
			Yellow	If the yellow indicator lamp comes on, it indicates that the intelligent high beam is faulty.
32		High beam indicator lamp	Blue	If the blue indicator lamp comes on, it indicates that the high beam is on.
33		IMMO indicator lamp*	Red	If the red indicator lamp comes on, it indicates that the engine immobilizer system or the body anti-theft system is working.
34		Position lamp indicator lamp	Green	If the green indicator lamp comes on, it indicates that the position lamp, instrument panel lamp, license plate lamp, ambient light, etc. are on.
35		Front fog lamp indicator lamp*	Green	If the green indicator lamp comes on, it indicates that the front fog lamp is on.
36		Rear fog lamp indicator lamp	Yellow	If the yellow indicator lamp comes on, it indicates that the rear fog lamp is on.
37		Hill descent control (HDC) indicator lamp	Yellow	If the yellow indicator lamp comes, it indicates that the HDC system is activated.
38		TJA/ICA indicator lamp *	White	If the white indicator lamp comes on, it indicates that the TJA/ICA is in the ready state and does not control the longitudinal and lateral directions of the vehicle.
			Green	If the green indicator lamp comes on, it indicates that the TJA/ICA is activated and may control the longitudinal and lateral directions of the vehicle simultaneously, or the horizontal control may be suppressed currently.
39		Gasoline particulate filter (GPF) indicator lamp	White	If the white indicator lamp comes on, it indicates that the accumulated carbon of the GPF exceeds a certain limit, and it is necessary to run at a high speed for more than 40 minutes to clean the carbon.
			Yellow	If the yellow indicator lamp comes on, it indicates that the accumulated carbon of the GPF is excessive, and it is necessary to go to the GAC Motor authorized shop for cleaning.

Note: If any indicator or warning lamp appears in the instrument cluster after the vehicle is started or during driving, it indicates that the related system or function is in a certain working state or faulty. You should read carefully and understand the meaning of each indicator or warning lamp. In case of a fault, please go to or contact the GAC Motor authorized shop for inspection in time.

4.2 Vehicle locking and unlocking

4.2.1 Remote control key

The vehicle equipped with ENGINE START/STOP button* has an intelligent remote control key (including emergency mechanical key => [See page 266](#)) and the corresponding key barcode; the vehicle equipped with traditional ignition switch* has a conventional remote control key (including mechanical key => [See page 266](#)) and the corresponding key barcode. If the key needs to be re-customized, please bring the key barcode to the GAC Motor authorized shop; if the key or its barcode is missing, please contact the GAC Motor authorized shop.

CAUTION

After the engine is started, do not put the remote control key on the instrument panel below the front windshield; otherwise, the prompt "No key detected" may appear.

Poor signal strength of remote control key

The operation of the remote control key button may be interfered or unstable in the following cases:

- Nearby equipment is emitting strong radio waves.
- The remote control key is carried together with telecommunication equipment, laptop, mobile phone, or wireless signal transmitter.
- The remote control key is put together with magnetic cards (such as bank card and bus card).
- Metal objects contact or cover the remote control key.

CAUTION

The remote control key contains an electronic circuit that can trigger the engine immobilizer system. If the circuit is damaged, the engine may not be started. Therefore,

- Avoid placing the remote control key in direct sunlight or in a high-temperature or humid place.
- Avoid dropping the remote control key from a high place or crushing it by heavy objects.
- Avoid exposing the remote control key to any liquid. If the key gets wet accidentally, dry it immediately.

NOTE





- The buttons of the remote control key cannot be operated when the ENGINE START/STOP button is in the "ACC" or "ON" position.
- If the unlocking or locking function of the remote control key is deactivated, you can try to press the buttons on the remote control key 3 times continuously to activate the function.

4. Operation of systems and equipment

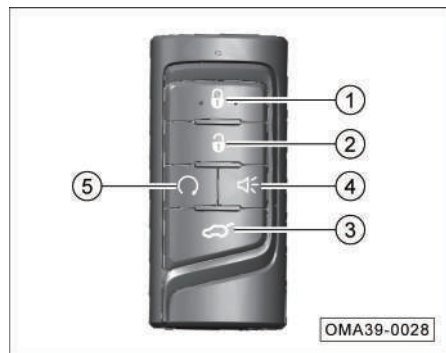
Button operations



Key with PEPS function



- ① : Locking button
- ② : Unlocking button
- ③ : Liftgate unlocking button
- ④ : Anti-theft alarm button*
- ⑤ : Engine start/stop button*

Key with conventional ignition switch function



- ① : Locking button
- ② : Unlocking button
- ③ : Liftgate unlocking button

① Button operations

- Within the effective range, if you press the button once, all doors will be locked; if you press and hold it for 2 s, the driver's window will be closed automatically; if you press and hold it for 3 s, the sunroof* will be closed automatically. If you release the button during the automatic closing of the window or sunroof, the window or sunroof will stop moving.
- If this button is pressed twice consecutively within 0.5 s, the vehicle locating function will be activated and the turn signal lamps will flash 4 times quickly.

② Button operations



- Within the effective range, if you press the button once, all doors will be unlocked; if you press and hold it for 2 s, the driver's window will be opened automatically; if you press and hold it for 3 s, the sunroof* will be opened automatically. If you release the button during the automatic opening of the window or sunroof, the window or sunroof will stop moving.

4. Operation of systems and equipment

CAUTION

Before closing the windows or the sunroof by the remote control key, make sure that there are no body parts (such as head and hands) in the movement path of the windows or the sunroof so as to prevent a risk of pinch injury.



NOTE

- The remote control key cannot control the tilting of the sunroof.
- This function can be activated or deactivated via “Vehicle Settings → Intelligent Body → Remote Control Windows” in the AV system.
- When the doors are locked, the turn signal lamps will flash once and the horn will sound once. When the doors are unlocked, the turn signal lamps will flash twice and the horn will sound twice. The horn can be activated or deactivated by settings of “System Settings → Sound Effect Settings → System Sound Effect → Unlocking/Locking Buzzer” of the AV system.
- All the four doors or the left front door can be unlocked by setting the  button via “Vehicle Settings → Intelligent Body → Lock/Unlock → Remote Unlock” in the AV system.
- After the  button is pressed to unlock the door, if the door is not opened within 30 s, the system will re-lock the door.

③ Button operations



- If this button is pressed and held for 2 s within the effective range, the back door will be unlocked. For the vehicle with electric liftgate, if the  button is pressed when the electric liftgate is being opened, the liftgate will stop being opened.

④ Button operations*



- If the  button is pressed and held for 3 s, the anti-theft alarm will be triggered, then the horn will sound and the turn signal lamps will flash for 30 s; if the  or  button is pressed, the anti-theft alarm will be stopped.

4. Operation of systems and equipment

⑤ Button operations*



- Within the effective range, if the  button is pressed and then the  button is pressed and held within 2 s, the turn signal lamps will flash and the engine can be remotely started.
- Then if the  button is pressed and held for 3 s, the engine can be remotely stopped.

NOTE

- Before remotely stopping the engine, make sure that the vehicle is in the locked state, and if you are not sure about it, press the  button once, and then press and hold the  button to remotely stop the engine.
- To remotely stop the engine, keep the key within the effective range, otherwise the unlocking function may be triggered and then the engine cannot be started.

Switching between audible-visual alarm and visual alarm

The visual alarm is to remind the owner of the vehicle only through the flashing of the turn signal lamps; the audible-visual alarm is to remind the owner of the vehicle through both the flashing of the turn signal lamps and the sounding of the horn.

When the ENGINE START/STOP button is in the "OFF" position, if the  and  buttons on the remote control key are pressed and held for 2 s at the same time, the audible-visual alarm and the visual alarm can be switched between each other. If the switching is successful, the turn signal lamps will flash 3 times (only for electronic anti-theft alarm).

NOTE

The switching function is only applicable to the anti-theft alarm. For details, please refer to the basic operations of body anti-theft. => [See page 73](#)

Battery replacement

Each time you press the buttons on the remote control key, the indicator lamp of the key will flash once. If the indicator lamp fails to flash, or you need to press the buttons several times to lock or unlock the doors, the battery may be exhausted or about to run out. It is recommended to go to GAC Motor authorized shop for the battery replacement.

CAUTION

- Be sure to replace the battery with a new one of the same rated voltage and size.
- An inappropriate battery may damage the remote control key.
- Always comply with relevant environmental regulations to dispose the exhausted battery.

4. Operation of systems and equipment

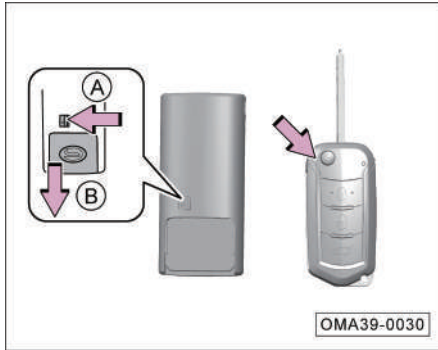

- Key of the model with ENGINE START/STOP button*: Pull the switch in the direction of arrow A and pull out the emergency mechanical key in the direction of arrow B.
- Key of the model with conventional ignition switch*: Press the button as arrowed to pop out the mechanical key.

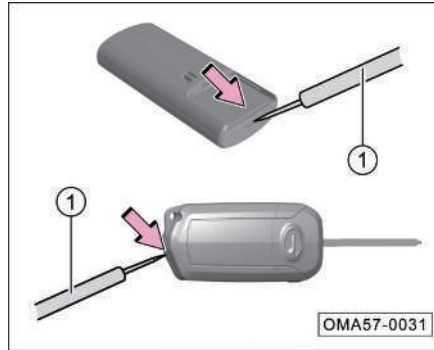

- Use a mini slotted screwdriver ① to pry open the remote control key housing at the arrowed position.

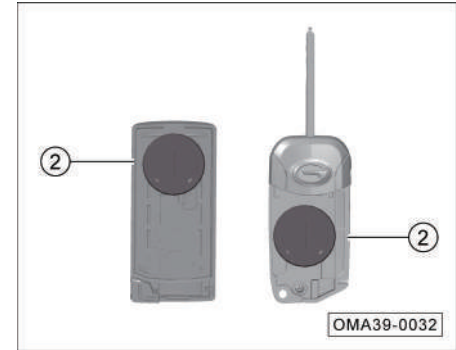

- Take out the battery ②.
Assemble the remote control key in the reverse steps mentioned above.

4. Operation of systems and equipment

4.2.2 Mechanical key

Emergency mechanical key*

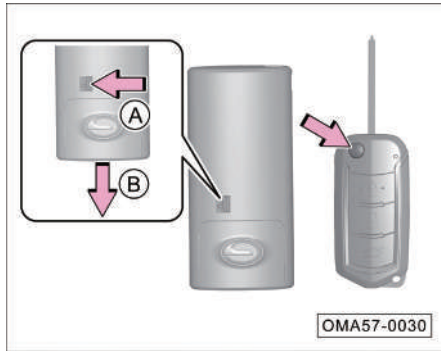

- Key of the vehicle model with ENGINE START/STOP button*: Pull the switch in the direction of arrow A, and pull out the emergency mechanical key in the direction of arrow B, which may be used to lock all doors or unlock the driver's door, but cannot start the engine.
- Key of the vehicle model with conventional ignition switch*: Press the button as arrowed to pop out the mechanical key, which may be used to lock all doors, unlock the driver's door, or start the engine.

Spare mechanical key*





- The spare mechanical key can be used to lock all doors, unlock the driver's door, or start the engine.

4.2.3 Door lock system

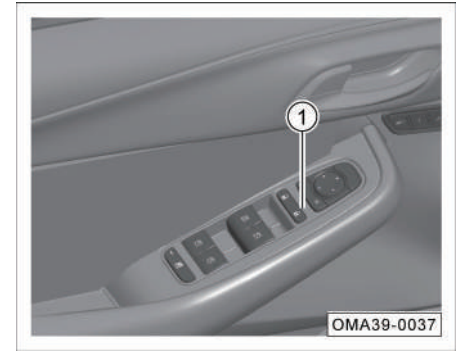
Central locking control button



- Lock all the doors: Press the  button of ①.
- Unlock all the doors: Press the  button of ①.

4. Operation of systems and equipment

Door inside handle

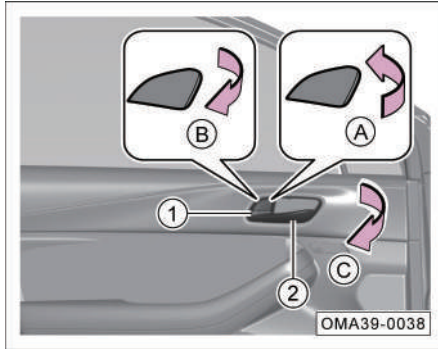

- If the door latch ① is pushed inward in the direction of arrow A, the corresponding door can be locked.
- If the door latch ① is pulled out in the direction of arrow B, the corresponding door can be unlocked; then if the inside handle ② is pulled in the direction of arrow C, the door can be opened.

CAUTION

- When the child safety lock is activated (=> [See page 56](#)), even if the rear door latch is unlocked, the inside handle cannot open the rear door. In this case, the rear door shall be opened from outside. And do not pull the inside handle with force to avoid damages.
- During driving, please ensure that all doors are closed properly and locked.
- During driving, do not pull the door inside handle so as to avoid accidents.
- When opening or closing the door, it is required to check the vehicle surroundings. For example, when the vehicle runs on a slope, check if the door can be opened properly and if high wind occurs. When opening or closing the door, please grasp the door handle tightly for fear of any accidental movement.

Door lock hole

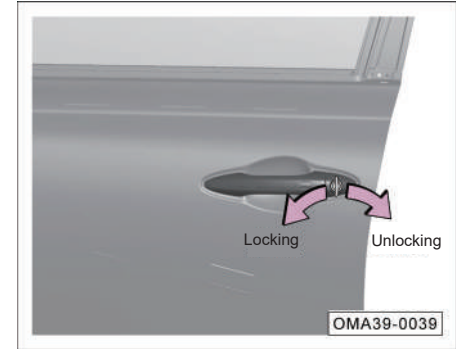



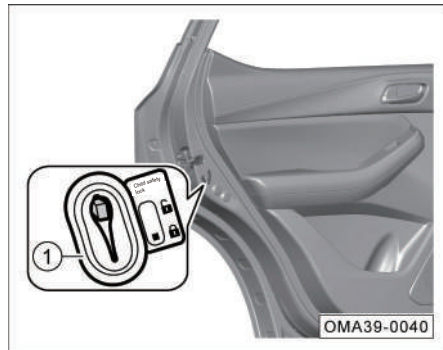

- Take out the mechanical key. => [See page 54](#)
- Insert the mechanical key into the driver's door lock hole.
- Turn the key clockwise to lock all the doors.
- Turn the key counterclockwise to unlock the driver's door only.

4. Operation of systems and equipment

Child safety lock



- Activation: Turn the child safety lock switch ① from  to  position to activate the child safety lock.
- Deactivation: Turn the child safety lock switch ① from  to  position to deactivate the child safety lock.

CAUTION

When the child safety lock is activated, the inside handle cannot open the rear door. In this case, the rear door shall be opened from outside. And do not pull the inside handle with force to avoid damages.

WARNING

- **The child safety lock can prevent children in the vehicle from unintentionally opening the rear door and thus reduce the risk of accidents.**
- **Never leave children or handicapped persons in the vehicle alone. Once the doors are locked, it is difficult for children or handicapped persons to leave the vehicle in an emergency; the locked doors in an accident will make it more difficult to rescue persons inside the vehicle.**

Speed sensing door lock

If this function is activated with all doors closed, the vehicle will be automatically locked at certain vehicle speed or after certain driving time.

When all doors are locked either automatically or manually and the ignition switch is in "ON" position, if the system detects that the vehicle has suffered a severe collision, all doors will be automatically unlocked. However, depending on the impact force and range, the system may not work under extreme conditions.

NOTE

- Please read the above related content before activating this function.
- This function is deactivated by default during delivery of the vehicle, and can be activated or deactivated via "Vehicle Settings → Intelligent Body → Speed Sensing Door Lock" of the AV system.

4. Operation of systems and equipment

Collision unlock function

In a collision where specified impact force is reached and the ignition switch is in "ON" position, the four doors will be simultaneously unlocked, and will be simultaneously unlocked again 3 s later.

Automatic unlock function

If the vehicle stops with the doors locked and the ignition switch set to "OFF" position, the four doors will be automatically unlocked.

i NOTE

This function can be activated or deactivated via "Vehicle Settings → Intelligent Body → Auto Unlock" of the AV system.

Intelligent active unlock*



- When the intelligent active unlock function is activated and the intelligent remote control key is brought to the area within 1 m of the vehicle, the vehicle will be automatically unlocked.

i NOTE

- This function can be activated or deactivated via "Vehicle Settings → Intelligent Body → Intelligent Active Unlock" in the AV system.
- If the intelligent active unlock is successful, the turn signal lamps will flash twice and the horn will sound twice.
- When the vehicle is parked for more than 7 days, the intelligent active unlock function will be automatically deactivated in order to reduce the power consumption of the vehicle, and in this case, you need to use the intelligent remote control key or touch the door handle to unlock the doors, and after the vehicle is started, the intelligent active unlock function will be restored.

4. Operation of systems and equipment

Intelligent active lock*



- When the intelligent active lock function is activated, the ignition switch is in "OFF" position and all doors are closed, if the intelligent remote control key is taken away from the vehicle within 2 m for more than 2 minutes or more than 2 m, the vehicle will be automatically locked.

- If the intelligent remote control key is taken away from the vehicle within 2 m for more than 2 minutes, the intelligent active lock function will be deactivated temporarily for power saving purpose, and if more than 4 minutes, the intelligent active unlock function, intelligent courtesy lamp and other functions will be deactivated temporarily. You need to open and then close one of the doors to re-activate the intelligent active lock function.

i NOTE

- This function can be activated or deactivated via "Vehicle Settings → Intelligent Body → Intelligent Active Lock" in the AV system.
- If the intelligent active lock is successful, the turn signal lamps will flash once and the horn will sound once.
- If the key is within 2 m from the vehicle, the indicator lamp of the intelligent remote control key will flash continuously until the doors are locked.

i NOTE

- If the intelligent active lock is successful but the liftgate is ajar, the audible and visual alarms will be sent to remind you.
- If one of the doors is ajar, there will be a corresponding indication on the instrument cluster.
- If the user approaches the vehicle within 3 s after the intelligent active lock is activated, the system will not activate the intelligent active unlock but will consider that the user wants to confirm whether the vehicle is locked. The user can confirm whether the doors are locked by pulling the rear door handles.
- With the ignition switch set to "OFF" position, when the liftgate is open and the intelligent remote control key is in the vehicle, the vehicle will be automatically locked after 10 min, accompanied by a beep indicating that the liftgate is not closed; at that time, if the liftgate is closed, the vehicle will be unlocked, lest the intelligent remote control key might be locked in the vehicle.

4. Operation of systems and equipment

It should be noted that the intelligent active lock function will not be activated in case of the followings:

- The ignition switch is in "ACC" or "ON" position.
- The intelligent remote control key is in the vehicle.
- No intelligent remote control key is detected within 2 m of the vehicle.
- Any door (excluding the liftgate or engine hood) is ajar.
- The intelligent remote control key is thrown into the vehicle from the door window.
- The intelligent remote control key is too close to the vehicle.

CAUTION

- The intelligent active lock function cannot automatically close the door windows, so before leaving the vehicle, make sure that all door windows and the sunroof are closed.
- Do not leave children or handicapped persons in the vehicle alone when using the intelligent active lock function.

PEPS system*



When the ENGINE START/STOP button is in the "OFF" position, if you bring the intelligent remote control key to approach the vehicle doors and put your hand into the (unlocking area) inside the front door handle, all the doors will be unlocked after effective induction.

When the ENGINE START/STOP button is in the "OFF" position, if you take the intelligent remote control key from the vehicle, close all the doors and touch the groove (locking area) on the front door handle as arrowed, all the doors will be locked after effective induction.

CAUTION

- After using the PEPS function to lock the doors, please wait for 5 s before using it again to unlock the doors.
- If you touch the unlocking and locking areas at the same time, priority will be given to the unlocking function, so please do not touch them at the same time.
- If there is snow or ice on the front door handle, the PEPS function will be affected, so please clear the snow or ice as soon as possible.
- If the front door handle gets wet and the intelligent remote control key is within the effective range during heavy rain or vehicle washing, the doors may be unlocked.

4. Operation of systems and equipment

CAUTION

- If you touch the front door handle while wearing gloves, the door sensor may slowly respond to or may not respond to unlock the doors.
- If you grab the front door handle and pull it immediately, the doors may not be opened. Please grab the handle again and confirm that the doors are unlocked, and then pull the handle.
- Even within 1 m, if the intelligent remote control key is higher or lower than the front door handle, the PEPS system may fail to lock/unlock the doors.
- If the intelligent remote control key is too close to the doors and the door windows, the PEPS system may not work properly; if the working distance of the remote control transmitter changes, the battery power may be low.



- When the ENGINE START/STOP button is in the "OFF" position, if you carry the intelligent remote control key to approach the liftgate, and press the liftgate unlocking button ①, the liftgate will be unlocked and opened.
- When the vehicle is in unlocked and stationary state, if you press the liftgate unlocking button ① directly without carrying the intelligent remote control key, the liftgate will also be unlocked and opened. In addition, the liftgate can be automatically opened*.

4.2.4 Door

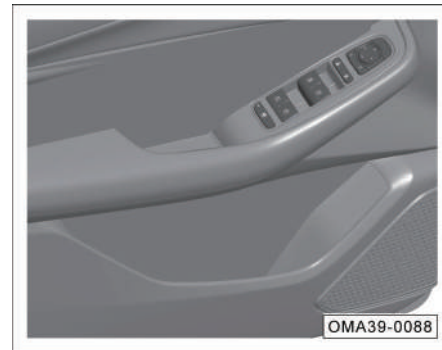

- To close the door in the vehicle, grab the door armrest and pull it inward.
- To close the door outside, directly push the outside door handle toward the vehicle.

CAUTION

Before opening the door, always pay attention to other vehicles or pedestrians outside the vehicle to avoid accidents caused by collision.

WARNING

- Always ensure that all doors are closed to prevent suddenly opening during driving, which may cause personal injuries or accident.
- Open or close the doors only when the vehicle is stationary.
- Do not put your hands on the edge of the door when closing the door, otherwise there will be a risk of pinching.

NOTE

- If the door is not closed properly, please re-open the door and close it again.
- If the door is ajar, there will be a corresponding indication on the instrument cluster; then when the vehicle speed exceeds 5 km/h, there will be a buzzer sound.

4.2.5 Liftgate

Unlocking liftgate with remote control key

When the remote control key is within the effective range, press and hold the  button on it to unlock the liftgate.

- When the power liftgate function* is deactivated or it is not a power liftgate, the liftgate needs to be opened manually.
- For a power liftgate, when the power liftgate function is activated, the liftgate will be opened to the maximum automatically. In this process, if you press this button again, the liftgate will stop opening.

Unlocking liftgate with PEPS system

When the intelligent remote control key is within the effective range, press the liftgate unlocking button on it to unlock the liftgate. => [See page 60](#)

- When the power liftgate function* is deactivated or it is not a power liftgate, the liftgate needs to be opened manually.
- When it is a power liftgate and the power liftgate function is activated, the liftgate will be opened to the highest position. In this case, if you press this button during the opening process, the liftgate will stop at the current position.

NOTE

When the vehicle is in unlocked and stationary state, if you press the liftgate unlocking button directly without carrying the intelligent remote control key, the liftgate will also be opened.

4. Operation of systems and equipment

Unlocking liftgate with button on instrument panel*



Press and hold the liftgate button on the instrument panel to open the liftgate to the maximum (or the set position => [See page 63](#)) automatically. In this process, if you press this button, the liftgate will stop opening.

i NOTE

When the liftgate is opened in this case, the turn signal lamps will flash and the buzzer will sound intermittently.

Power liftgate (PLG) main switch*

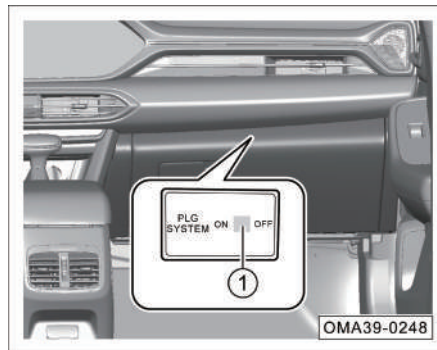

The PLG main switch is located in the glove box. Open the glove box:

- To activate the PLG function, turn the main switch ① to the "ON" position.
- To deactivate the PLG function, turn the main switch ① to the "OFF" position.

Open PLG*

- The PLG can be opened when the vehicle speed is lower than 3 km/h.

Close PLG*

- The closing of the PLG is not limited by the vehicle speed.
- The PLG can be closed only after the pull-in lock catch is released.

i NOTE

If the PLG fails to be opened/closed, please check whether the PLG main switch is in the "ON" position. If it still fails with the main switch in the "ON" position, please go to the GAC Motor authorized shop for inspection in time.

4. Operation of systems and equipment

PLG opening height setting*

When the PLG is opened to more than half of the travel, the opening can be set. After the setting is successful, the PLG can only be opened to the setting next time it is opened.

Set the opening height

Open the PLG to the desired height position and stop it, then press and hold the liftgate locking button for more than 2 s and release it after hearing the buzzer sound, thus completing the height setting.

Cancel the set height

To cancel the set height, just manually open the PLG to a position higher than the set height.

i NOTE

- If the height setting is successful, the buzzer will sound twice.
- If the set height is canceled, the buzzer will sound once.

PLG anti-pinch function*

1. Anti-pinch function of anti-pinch strip

This is effective during the opening and closing of the PLG:

- If this function is triggered, the PLG will stop being closed and return to the original opening position.

2. Obstacle detection and anti-pinch function

This is effective during the closing of the PLG:

- If this function is triggered during the closing of the PLG, the PLG will stop being closed and return to the original opening position.
- If this function is triggered during the opening of the PLG, the PLG will stop being opened and then be slightly closed and finally stop moving.

i NOTE

If the anti-pinch function is triggered, the buzzer will sound three times.

Protection function

Continuous anti-pinch protection

- If the anti-pinch function is triggered three times consecutively during the closing, the PLG function will be deactivated and then needs to be reactivated by manually full closing of the PLG.

Overheat protection

- When the motor reaches over temperature after running continuously for a period of time, the overheat protection will be activated, then the PLG function will be deactivated for a while and then reactivated.

Deactivate PLG function

- If the battery cable is disconnected when the liftgate is ajar, the position of the liftgate will be lost, so the PLG function will be deactivated and then needs to be reactivated by manually full closing of the PLG.
- During the ignition process, the PLG opening or closing signal request is not responded.

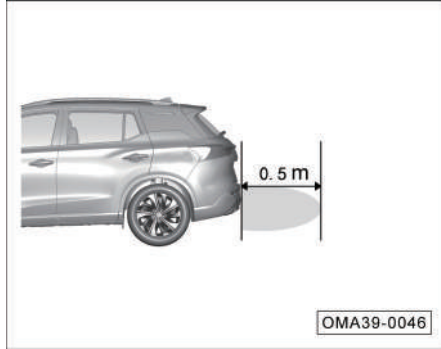

4. Operation of systems and equipment

Easy open of liftgate*



- When the ENGINE START/STOP button is set to "OFF" position and the four doors and liftgate are closed, if you take the key to enter the liftgate sensing area within about 0.5 m, the horn will sound once and the high-mounted stop lamp will start to flash. At that time, if you stay there for 3.2 s, the liftgate will be electrically opened, and if you leave the sensing area after hearing the honk, the liftgate will not be opened.

i NOTE

- When the liftgate is automatically opened, the horn will sound once, the high-mounted stop lamp will flash 4 times, and the turn signal lamps will flash 2 times.
- If you leave the liftgate induction area or press the  button on the intelligent remote control key during the flashing of the high-mounted stop lamp, this function will be temporarily deactivated and the liftgate will not be opened. If this function is deactivated by pressing the  button on the intelligent remote control key, you need to open and close one of the front doors to reactivate it.
- This function can be activated or deactivated via "Vehicle Settings → Intelligent Body → Liftgate Easy Open" in the AV system.

👁 CAUTION

- When washing the vehicle, make sure that the intelligent remote control key is outside the induction area of the liftgate, otherwise the liftgate will be opened. Therefore, it is recommended to deactivate this function in this case.
- If you pick up something near the liftgate while carrying the intelligent remote control key, please note that the liftgate may be opened.
- Before activating the easy open function to open the liftgate, make sure that no one or obstacle is within the movement range of the liftgate.

4. Operation of systems and equipment

Emergency opening of liftgate

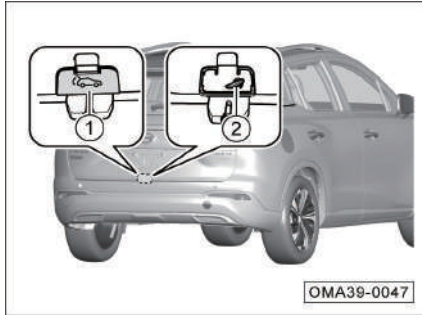

When the vehicle is out of power or the liftgate fails to be opened normally, you can try the emergency interior opening of liftgate:

1. Open the liftgate trim cover ①.
2. Insert the mechanical key ② into the groove of the unlocking mechanism and turn the key to unlock and open the liftgate.

i NOTE

If the emergency interior opening of liftgate fails, please go to the GAC Motor authorized shop for inspection in time.

Close liftgate

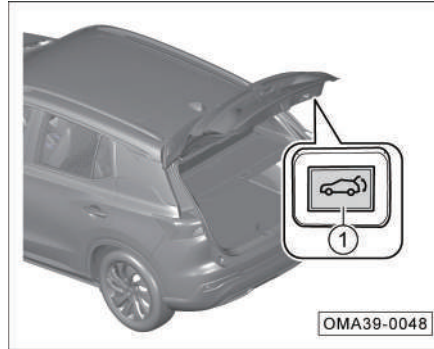

Manual closing

When the power liftgate function* is deactivated or it is not a power liftgate, the liftgate needs to be closed manually:

- Lower the liftgate close to the rear bumper cover, and then press down the liftgate firmly with both hands to close it.

PLG closing*

- If you press the liftgate locking button ①, the PLG will be automatically lowered until it is closed. In this case, if you press this button again during the closing process, the liftgate will stop at the current position.
- With the ENGINE START/STOP button set to "OFF" position, when the intelligent remote control key is within the  effective range, press and hold the button on it to close the PLG fully automatically. In the closing process, if you press the button again, the PLG will stop closing.
- Press and hold the liftgate button on the instrument panel to close the PLG fully automatically. In the closing process, if you press the button again, the PLG will stop closing.

4. Operation of systems and equipment

i NOTE

- When the PLG is closed, the turn signal lamps will flash twice.
- When the PLG is closed, the buzzer will sound once.
- If the PLG is ajar, there will be a corresponding indication on the instrument cluster; then when the vehicle speed exceeds 5 km/h, there will be a buzzer sound.

⚠ WARNING

- **The PLG must always be closed fully, otherwise accidents may easily occur.**
- **Be careful when closing the PLG to ensure that no person is within the movement range of the PLG.**
- **Always ensure that the closed PLG is locked to prevent suddenly opening during driving.**

4.2.6 Engine hood

Unlocking of engine hood

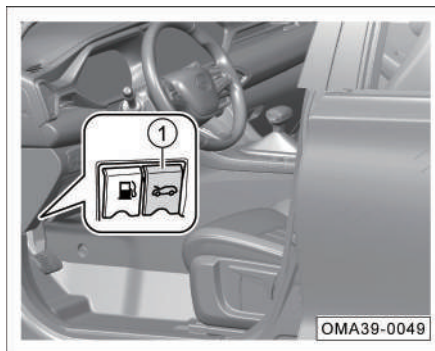

- If the engine hood release handle ① is pulled, the engine hood will be unlocked and pop up slightly.

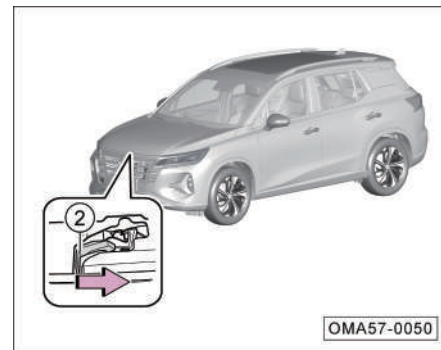

- If the locking mechanism ② is pushed as arrowed, the engine hood will be fully unlocked.

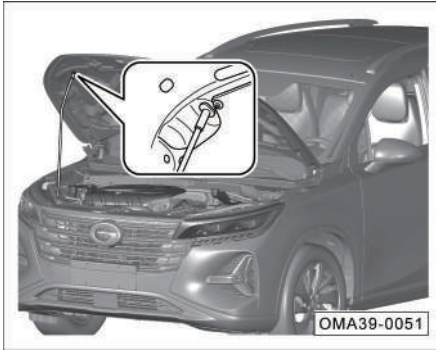

- If the engine hood is opened upward, the stay bars will support the engine hood.

Locking of engine hood

- Take out the stay bar, then lower the engine hood to a height close to the fenders, and press down the front end of the engine hood with force manually for firm locking.

i NOTE

- Proper lubrication of the locking mechanism moving parts of the engine hood is helpful for opening or closing the engine hood.
- If the engine hood is ajar, there will be a corresponding alarm indication on the instrument cluster; then when the vehicle speed exceeds 5 km/h, there will be a buzzer sound.
- Always ensure that the closed engine hood is locked to prevent suddenly opening during driving, which may cause an accident.

⚠ WARNING

The engine compartment is a high-risk area! Improper operation can easily cause casualties.

- **If steam or coolant flows out from the engine compartment, do not open the engine hood, for fear of burns!**
- **Never touch the hot engine, for fear of burns!**
- **Do not open the expansion tank cap when the engine is hot, at which the cooling system is under high temperature and high pressure.**
- **If you have to work during the engine start-up or operation, do not touch the rotating parts such as drive belt, alternator and radiator fan and the high-pressure ignition system.**

4. Operation of systems and equipment

4.2.7 Power window

The power window can be operated when the ignition switch is in "ON" position. It will still be operable within 40 s after the ignition switch is turned from "ON" position to "ACC" or "OFF" position, but will become inoperable if one of the doors is opened within the 40 s.

CAUTION

- Please close all windows before leaving the vehicle.
- Do not put your hands on the edge of the window when closing the window; otherwise a risk of pinch may occur.

Driver's power window control button

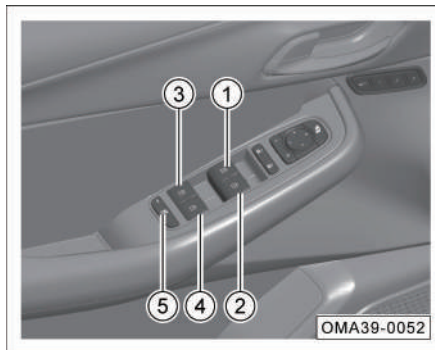

- ① Left front power window control button
- ② Right front power window control button
- ③ Left rear power window control button
- ④ Right rear power window control button
- ⑤ Passenger's power window control button

- If the button ① is pulled up to the first stop position, the power window will be lifted for closing until the button is released or the window reaches the highest position.
- If the button ① is pulled up with force, the power window will be lifted automatically for closing until the window reaches the highest position.
- If the button ① is pressed down slightly, the power window will be lowered for opening until the button is released or the window reaches the lowest position.
- If the button ① is pressed down with force, the power window will be lowered automatically for opening until the window reaches the lowest position.

NOTE

- If you want to stop the window during its automatic lifting or lowering, just press down or pull up the button ①.
- The operation methods of buttons ②, ③ and ④ are the same as that of button ①.

4. Operation of systems and equipment

i NOTE

The left front door window with anti-pinch function only allows express-up.

- If you press the passenger's power window control button ⑤, the button indicator lamp will come on and the passenger's power windows cannot be operated anymore. If you press this button again, this function will be deactivated and the button indicator lamp will go out.

Passenger's power window control button

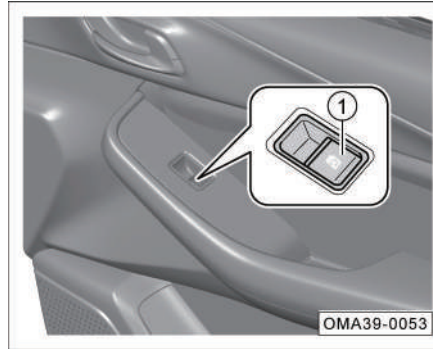

- For the operation methods of the passenger's power window control button ①, please refer to the driver's power window control button.

Initialization of anti-pinch function*

If the express-up feature is not available, or the anti-pinch function fails, the power window needs to be initialized.

1. Pull up the left front power window control button to lift the window in steps until it is completely closed.
2. After the window is completely closed, continue to pull up the left front power window control button and hold it for 2~3 s to complete the initialization.



WARNING

- **If the window has no anti-pinch function during the initialization learning process, please do not use any part of your body or other objects to hinder the closing of the window, otherwise it will cause personal injury and affect the result of the initialization learning.**
- **If the power window system fails, please go to the GAC Motor authorized shop for inspection in time.**

4. Operation of systems and equipment

4.2.8 Electric sunroof

The power sunroof can be operated when the ignition switch is in "ON" position. It will be still operable within 40 s after the ignition switch is turned from "ON" position to "ACC" or "OFF" position, but will become inoperable if one of the doors is opened within the 40 s.

i NOTE

When the ignition switch is in the "OFF" position with the electric sunroof not closed and the driver's door opened, the instrument cluster will display the message "Sunroof Open" and send a buzzer sound to remind you; in this case, be sure to check whether the sunroof is closed.

👁 CAUTION

Please close the sunroof, lest a risk of water ingress may occur on rainy days.

Sun visor

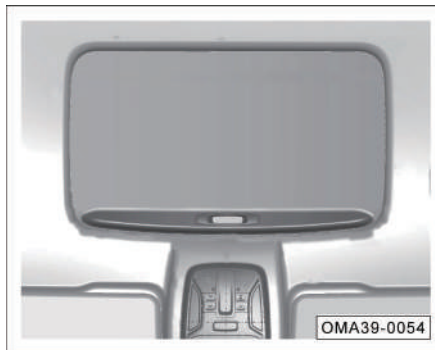

- Automatic opening: The sun visor will be automatically opened as the sunroof is opened by sliding.
- Manual opening: Just push the sun visor backward.
- Manual closing: Just push the sun visor forward after the electric sunroof is closed.

Opening or closing sunroof

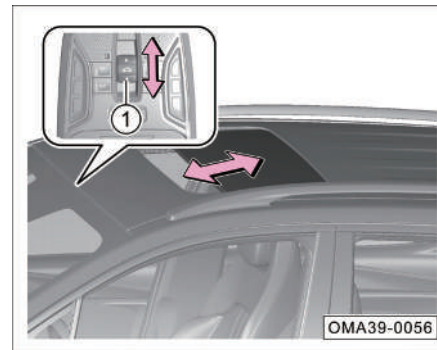

- If you push the sunroof switch ① backward, the sunroof will move a short distance for slight opening and then stop.
- If you push the sunroof switch ① forward, the sunroof will move a short distance for slight closing and then stop.

4. Operation of systems and equipment

- If you push the sunroof switch ① backward and hold it for several seconds, the sunroof will be fully opened automatically.
- If you push the sunroof switch ① forward and hold it for several seconds, the sunroof will be fully closed automatically.

i NOTE

If the sunroof switch ① is pushed again during the automatic opening or closing of the sunroof, the sunroof will stop at the current position.

Tilting sunroof

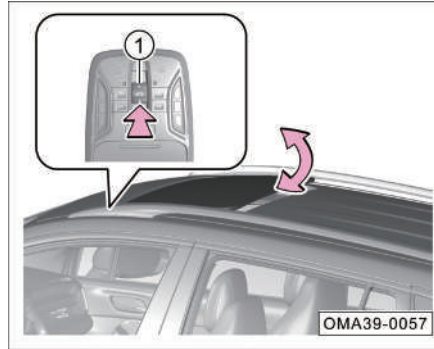

- When the sunroof is fully closed, open the sun visor manually, and press the  button on the sunroof switch ① upward to tilt the sunroof outward. Just push the sunroof switch ① forward to deactivate the tilting function.

Anti-pinch function of sunroof

The anti-pinch function is available for the closing of the sunroof:

- When the sunroof is closed by sliding, if the anti-pinch function is activated, the sunroof will move in the opening direction for a certain distance and then stop.
- When the sunroof is closed by tilting, if the anti-pinch function is activated, the sunroof will move in the outward tilting direction until it reaches the maximum tilting position.

CAUTION

Do not operate the sunroof when the ambient temperature is below -20°C , at which the anti-pinch function of the sunroof may not be activated, resulting in accidents. In addition, the low temperature will also damage the motor to a certain extent.

4. Operation of systems and equipment

WARNING

- The anti-pinch function of the sunroof cannot prevent pinching of light or thin objects.
- When closing the sunroof, make sure that no one is within the movement range of the sunroof to avoid pinch.
- The sunroof will stop detecting obstacles at a position where the sunroof is about to be closed fully, so the anti-pinch function will be deactivated at this time.
- Do not try to activate the anti-pinch function by your hand or any part of your body, otherwise there will be a risk of pinching.



Speech operations

The speech operations can be used to open, close and tilt the sunroof:

- If you say "Open sunroof", the sunroof will be fully opened automatically, during which the sun visor will be opened by the mechanical structure.
- If you say "Close sunroof", the sunroof will be fully closed automatically. But the sun visor needs to be closed manually.
- If you say "I need some fresh air/Tilt sunroof", the sunroof will be automatically opened first (so as to push open the sun visor), then closed and finally tilted.

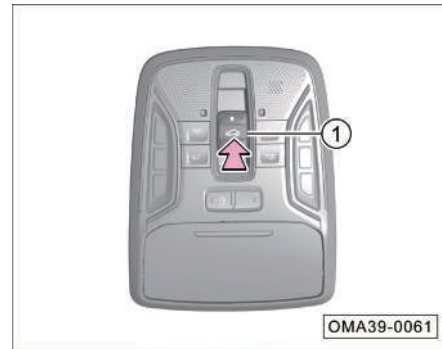
Manual initialization and self-learning of sunroof



- When the sunroof is tilted, if you press the  button on the sunroof switch ① upward and hold it for more than 10 s, the sunroof will start to be initialized.
- If you press the  button on the sunroof switch ① upward and hold it (or push the sunroof switch ① forward and hold it), the sunroof will be "closed by tilting → opened by sliding → closed fully" and then will stop, thus completing the self-learning.

CAUTION

If the electric sunroof system fails, please go to the GAC Motor authorized shop for inspection in time.

4.2.9 Basic operation of body anti-theft system

Body anti-theft function - unlock

When the ignition switch is in the “OFF” position and the vehicle is in the anti-theft state, if you bring the intelligent remote control key to approach the vehicle doors and put your hand into the (unlocking area) inside the front door handle for effective induction or if you unlock the vehicle by remote control, all the doors will be unlocked to release the vehicle from the anti-theft state, and the turn signal lamps will flash twice.

Body anti-theft function - lock

When the ignition switch is in “OFF” position and the four doors, engine hood and liftgate are all closed, if you take the intelligent remote control key away from the vehicle and put your hand into the locking area on the driver’s door handle for effective sensing* or if you lock the vehicle by remote control, all the doors will be locked to enable the vehicle to enter the anti-theft state, and the turn signal lamps will flash once.

Activation of body anti-theft function

When the ignition switch is in the “OFF” position and the vehicle is in the anti-theft state, if the door is unlocked by an illegal key or is forcibly unlocked, the anti-theft system will be activated, the anti-theft horn will sound and the turn signal lamps will flash twice for about 30 s.

When the vehicle is locked by remote control and enters the anti-theft state, if the driver’s door is unlocked with the mechanical key, the anti-theft system will trigger the horn to sound and the turn signal lamps will flash.

NOTE

Before or during the anti-theft alarm triggered, if you press the  button on the remote control key or switch the ignition switch to the “ON” position, the anti-theft alarm can be canceled and the vehicle can be released from the anti-theft state; the alarm can be triggered up to 10 times in one cycle.

4. Operation of systems and equipment

Engine immobilizer

When the ignition switch is switched from the “OFF” position to the “ON” position with the body anti-theft state released and the legal key in the vehicle, if the engine immobilizer system passes the verification, it will be deactivated.

If the engine immobilizer system does not pass the verification, the engine cannot be started and an immobilizer alarm will be triggered.

Body anti-theft maintenance instructions

No maintenance is required during normal use. If you have any doubt, please contact the GAC Motor authorized shop.

4.3 Lamps and vision

4.3.1 Exterior lamps

Lamp combination switch

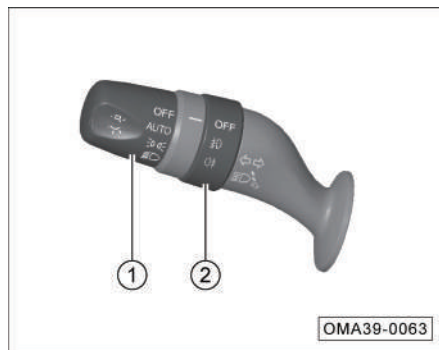

- ① Lamp switch
- ② Fog lamp switch

i NOTE

- Water vapors or even water drops may appear on the inner surfaces of the lamps under certain conditions (such as high air humidity and vehicle washing conditions), similar to the fogging phenomenon on the windows when the vehicle is traveling in the rain, but this is not a malfunction.
- This fogging phenomenon can be eliminated by parking the vehicle in a dry environment, turning on the lamps or driving the vehicle, but may recur.
- If there are a lot of water drops or water accumulates in the lamps, please contact the GAC Motor authorized dealer for inspection.

4. Operation of systems and equipment

Turn signal lamp

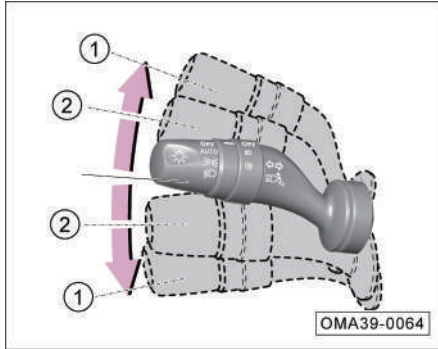

- When the engine ignition switch is in the "ON" position, if you turn the lamplight combination switch up or down to the limit position ① and turn on the right or left turn signal lamp, the corresponding indicator lamp ➡ or ⬅ on the instrument cluster will flash.

Turn signal lamp flashing for lane change

- In case of lane changing or overtaking, if you quickly turn the lamplight combination switch up or down to the position ② and then release it to the original position, the corresponding turn signal lamp and the indicator lamp ➡ or ⬅ on the instrument cluster will flash 3 times.

- If you turn the lamplight combination switch up or down and hold it at the position ②, the corresponding turn signal lamp and the indicator lamp ➡ or ⬅ on the instrument cluster will flash continuously. Releasing the switch to the original position can stop the flashing.

CAUTION

If the corresponding indicator lamp ➡ or ⬅ on the instrument cluster flashes faster, one of the turn signal lamps may be faulty. In that case, please go to the GAC Motor authorized shop for inspection in time.

Lamp switch



When the ignition switch is in the "ON" position, turn the lamp switch ① to activate or deactivate AUTO (automatic headlamp on/off function)*, 3RE (position lamp), and 10 (low beam).

When the lamp switch is turned to the "OFF" position, all lamps will go out.

4. Operation of systems and equipment

AUTO (automatic headlamp on/off function)*

- Turn the lamplight switch to “AUTO” position to activate the automatic headlamp on/off function.

i NOTE

If the automatic headlamp on/off function is activated, the vehicle will automatically turn on or off the headlamp according to the ambient light. When the ambient light gradually becomes dark, the position lamps and the low beam will be turned on simultaneously; when the ambient light gradually becomes bright, the position lamps and the low beam will be turned off simultaneously.



CAUTION

- If the instrument cluster displays “Sensor Failure, Please Manually Control Light”, the system will keep the low beam on for the sake of safety. At this time, you should manually control the light and go to the GAC Motor authorized shop for inspection in time.
- The automatic headlamp on/off function may not be activated in the haze environment, so please manually control the light in this case.

Daytime running lamp

- When the engine is started and the position lamps are off, the daytime running lamps can be automatically turned on; when the position lamps are turned on or the engine is shut down, the daytime running lamps can be automatically turned off.

Position lamp

- If you turn the lamplight switch to the  position, the position lamps, instrument panel lamps, license plate lamps and other lamps will be turned on, and the corresponding indicator lamp  on the instrument cluster will come on.

i NOTE

If you forget to turn off the position lamps when the ignition switch is turned to “OFF” position and the vehicle is not locked, the position lamps will stay on for 15 min and then go out automatically in order to save the battery power; when the ignition switch is turned to “OFF” position and the vehicle is locked, the position lamps will go out immediately.

4. Operation of systems and equipment

WARNING

- When driving the vehicle at night or on a road with poor visibility, please do not only turn on the position lamps. Otherwise, accidents may easily occur.
- When temporarily parking the vehicle at night or on a road with poor visibility with the need of indicating the position of the vehicle, do not use the position lamps as the parking lamps but be sure to turn on the hazard warning lamp due to the battery power saving function of the position lamps.

Low beam

- Turn the lamp switch to the  position to turn on the low beam.

High beam

- After turning on the low beam, if you push the lamplight combination switch forward to the limit position, the high beam will be turned on and the corresponding indicator lamp  on the instrument cluster will come on.
- If you pull the lamplight combination switch backward to the original position, the high beam will be turned off.

Headlamp flashing

- If you pull the lamplight combination switch backward to the limit position, the high beam and low beam will be turned on.
- If you release the switch, the lamplight combination switch will automatically return to its original position and the high beam and low beam will be turned off.

NOTE

- The high beam may cause dazzling to drivers of oncoming vehicles at close range, which may easily cause accidents. Therefore, please use the high beam reasonably.
- When all the lamps are turned off, if you pull and hold the lamplight combination switch backward, the high beam and low beam will stay on, and the corresponding indicator lamp  on the instrument cluster will come on.

4. Operation of systems and equipment

Manual headlamp leveling



Rotate the knob ① to manually level the headlamp (low beam) at 0, 1, 2 and 3 positions. The level of the headlamp will decrease as the adjustment value increases.

Position lamp on warning

When the ignition switch is turned to the "OFF" position with the position lamps turned on, if you open the driver's door, the system will send a buzzer sound and the instrument cluster will display the message "Lamp On".

Headlamp delay off (follow me home) function

Within 10min after the ignition switch is turned to the "OFF" position, if you turn the lamp switch from the "OFF" position to other positions and then back to the "OFF" position within 2s, the Follow Me Home function will be activated. In this case, the low beam will stay on for 30s, within which if one of the doors (including four doors, engine hood and liftgate) is opened, this function will be re-timed, and then the low beam will stay on for 80s, within which if all the doors are closed, this function will be re-timed again, and then the low beam will stay on for 30s repeatedly.

i NOTE

This function can be activated or deactivated via "Vehicle Settings → Light Control → Follow Me Home" in the AV system.

Fog lamp switch



When the ignition switch is in the "ON" position with the position lamps turned on, turn the fog lamp switch ② to turn on or off the F D (front fog lamps) and R F (rear fog lamps).

- When the fog lamp switch ② is turned to the F D position, the front fog lamps will come on.
- After the fog lamp switch ② is turned to R F position and then released to F D position*, the rear fog lamp will come on. Repeat the operation to switch between turning on the front fog lamp* and turning on both the front* and rear fog lamps.

4. Operation of systems and equipment

- When the fog lamp switch is turned to “OFF” position, the front fog lamp* will go out.



i NOTE

For some vehicle models without front fog lamp, directly turn the fog lamp switch to  position to turn on the rear fog lamps after the ignition switch is turned to “ON” position and the lamplight switch is turned to the low beam position.

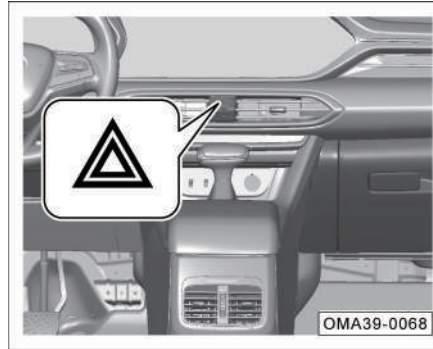
Hazard warning lamp



When the ignition switch is in any position, if you press the switch  , the switch red indicator lamp will come on and the hazard warning lamp will be turned on. Press this switch again to turn off the hazard warning lamps.

If the hazard warning lamp is turned on, all turn signal lamps and the indicator lamps  and  on the instrument cluster will flash simultaneously.

The hazard warning lamp shall be turned on in the following cases so as to attract the attention of persons on the road and reduce the risk of traffic accidents:

- The vehicle is involved in any failure.
- The vehicle is at the tail end of a traffic jam.
- The vehicle tows another vehicle or is towed.
- The vehicle is temporarily parked due to poor visibility.

i NOTE

- The use of the hazard warning lamp will consume the battery power, so please turn it off when not in use.
- Be sure to strictly abide by the relevant regulations when using the hazard warning lamp.
- In the event of an emergency, if the hazard warning lamp is faulty, other safety methods that comply with the relevant traffic rules and regulations must be taken to attract the attention of other persons on the road.

4. Operation of systems and equipment



Collision warning lamp

In the event of a vehicle collision, the left and right turn signal lamps will flash simultaneously.

Emergency brake warning lamp

When the vehicle is traveling at a high speed and the emergency brake is applied, the brake lamps will come on and the turn signal lamps will flash.

Car assisted lighting

- If you press the unlock button  on the remote control key within the effective range, the position lamps will stay on for 25 s for the purpose of helping you to approach your vehicle. If you press the unlock button  on the remote control key again, the position lamps can stay on for another 25 s. When the ignition switch is turned to "ON" position, the position lamps will go out.

Car locating lighting

- If you press the lock button  on the remote control key twice within 0.5s, the position lamps will stay on for 8s and the turn signal lamps will flash 4 times for the purpose of helping you to locate your vehicle.

Intelligent courtesy lamp*

- When the ignition switch is in the "OFF" position with all doors closed and locked, if you bring the intelligent remote control key to approach the vehicle, the courtesy lamp and the position lamps will come on automatically, and then if you don't open the door or take away the intelligent remote control key within 25s, the lamps will go out automatically.

CAUTION

If the engine has not been started for more than 7 days, the intelligent courtesy lamp function will be automatically turned off. When the engine is started, the intelligent Courtesy lamp function will be reactivated.

NOTE

This function can be activated or deactivated via "Vehicle Settings → Light Control → Intelligent Courtesy Lamp" in the AV system.

4.3.2 Interior lamp

Automatic light-on function of dome lamps



- Press the switch ① (depressed) to deactivate the automatic light-on function of dome lamps; press the switch ① (popping up) again to activate this function.

Delay off function of interior lamps

When the dome lamps are off and the automatic light-on function of dome lamps is activated:

- If the ignition switch is in the "OFF" position and one of the doors is opened, the dome lamps will come on automatically; the dome lamps will go out about 30s after the doors are closed.
- If the ignition switch is in the "OFF" position and the doors are unlocked remotely, the dome lamps will come on automatically and then go out after about 30s.
- If the ignition switch is turned from the "ON" position to the "OFF" position, the dome lamps will come on automatically and then go out after about 30s.

i NOTE

When all the doors are closed and the dome lamps are on as mentioned above, if the vehicle is locked remotely or the ignition switch is turned to the "ON" position, the dome lamps will go out automatically.

Dome lamp



- When the dome lamps are off, press the switch ① (depressed) to turn on all the dome lamps; press the switch ① (popping up) again to turn off all the dome lamps.

i NOTE

The switch ① will be invalid if it is not used to turn on the dome lamps.

4. Operation of systems and equipment



- With the front dome lamps off, press the switch ② (depressed) to turn on the front dome lamp on the corresponding side; press the switch ② (popping up) again to turn it off.

i NOTE

- The switch ② will be invalid if it is not used to turn on the front dome lamps.
- The operations for dome lamps on vehicle models with sunroof are described here, which also apply to vehicle models without sunroof.

Rear dome lamp



- When the rear dome lamps are off, press the switch ① to turn on the dome lamps; press the switch ① again to turn them off.

i NOTE

The switch ① will be invalid if it is not used to turn on the rear dome lamps.

4. Operation of systems and equipment

Trunk lamp

- If the liftgate is opened, the trunk lamp will come on automatically.
- If the liftgate is closed, the trunk lamp will go out automatically.

Courtesy lamp*

- If the door is opened, the courtesy lamp will come on automatically.
- If the door is closed, the courtesy lamp will go out automatically.

Vanity mirror lamp*

- If the vanity mirror cover is opened, the vanity mirror lamp will come on automatically.
- If the vanity mirror cover is closed, the vanity mirror lamp will go out automatically.

4.3.3 Wiper combination switch

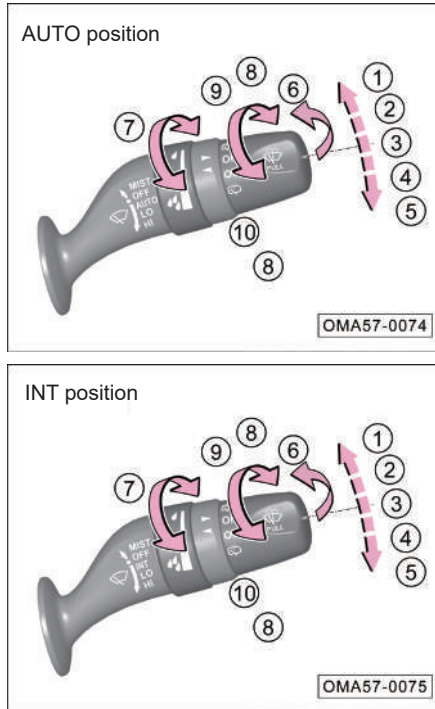

When the ignition switch is in the "ON" position, the wiper combination switch can be operated as follows:

- ① MIST: Continuous wiping
 - ② OFF: Front windshield wiper off
 - ③ AUTO: Automatic wiping*
- INT: Intermittent wiping*
 - ④ LO: Low speed wiping
 - ⑤ HI: High speed wiping
 - ⑥ Front windshield washer system on
 - ⑦ Adjusting knob:
 - Adjusting the sensitivity of automatic wiping (AUTO)*
 - Adjusting the intermittent wiping (INT)*
 - ⑧ : Rear windshield washer system on
 - ⑨ : OFF: Rear windshield washer or wiper off
 - ⑩ ON: Rear wiper on

4. Operation of systems and equipment

NOTE

When the front wiper is wiping intermittently/ at low speed/at high speed, if you shift to the “R” gear, the rear wiper and the front wiper will wipe synchronously.

MIST: Continuous wiping

- If the wiper combination switch is turned to the ① MIST position, the front wiper will start wiping continuously.
- If the wiper combination switch is released to automatically return to the ② OFF position, the front wiper will stop wiping.

OFF: Wiper off

- If the wiper combination switch is turned to the ② OFF position, the front wiper will stop wiping.

AUTO: Automatic wiping*

- If the wiper combination switch is turned to the ③ AUTO position, the automatic wiping function will be activated, and the wiper system will adjust the wiper speed according to the current rainfall and the real-time vehicle speed.
- The auto wiping function can be activated or deactivated via “Vehicle Settings → Intelligent Body → Auto Wiping” in the AV system. When this function is deactivated, the function of the wiper in the AUTO position is equivalent to that in the INT position.
- Adjust the wiping sensitivity by turning the knob ⑦ up/down.

CAUTION

- If the instrument cluster displays “Sensor Failure, Please Manually Control Wiper”, for the sake of safety, you should manually control the wiper and go to the GAC Motor authorized shop for inspection in time.
- Before activating the automatic wiping function in winter, please check whether the wiper blade is frozen.
- It is recommended to deactivate the automatic wiping function when cleaning the vehicle, in dusty weather and in rainless weather to avoid unintentional wiping of the wipers which may cause damage or personal injury.
- The automatic wiping function is an assist, so the driver should manually operate the wipers when necessary according to the driving situation to ensure driving safety.

4. Operation of systems and equipment

INT: Intermittent wiping*

- If the wiper combination switch is turned to the ③ INT position, the front wiper will start wiping intermittently.
- For the models equipped with the auto wiping function, intermittent wiping mode can be activated via “Vehicle Settings → Intelligent Body → Auto Wiping” in the AV system.
- Adjust the intermittent wiping speed by turning the knob ⑦ up/down.

LO: Low speed wiping

- If the wiper combination switch is turned to the ④ LO position, the front wiper will wipe at a low speed.

HI: High speed wiping

- If the wiper combination switch is turned to the ⑤ HI position, the front wiper will wipe at a high speed.

Front windshield washer system on

- If the wiper combination switch is turned toward the rear of the vehicle to the ⑥ position, the front washer will start spraying water and then the front wiper will start wiping.
- If the wiper combination switch is released to return to its original position, the front windshield washer system will be turned off and the front wiper will work for another two cycles.
- The front wiper will wipe again 6s later after stopping to remove the remaining water stains on the windshield.

Rear windshield washer system on

- When the liftgate is closed, if you turn the rear wiper knob up/down to the limit position ⑧ , the washer will start to work, after which the rear wiper will work.
- After the rear washer is turned off, the rear wiper will work for another 2 cycles, and then work for another 1 cycle after 6 s.

ON: Rear wiper on

- When the liftgate is closed, if you turn the rear wiper knob to the ⑩ ON position, the rear wiper will start wiping.

OFF: Rear windshield washer or rear wiper off

- If you turn the rear wiper knob to the ⑨ OFF position, the rear windshield washer system will be turned off or the rear wiper will stop wiping.

Front wiper maintenance

- Within 10 s after turning the ignition switch to the “OFF” position, if you turn the control lever of the wiper combination switch to the MIST position and then quickly release it to return it to the original position, the front wiper will move to the highest position and then stop.

NOTE

This function can be activated or deactivated via “Vehicle Settings → Intelligent Body → Front Wiper Maintenance” in the AV system.

4. Operation of systems and equipment

4.3.4 Windshield



Windshield glass

The green heat-insulation and laminated anti-scattering glass is used for the front windshield, which can effectively reduce the personal injury in an accident.

WARNING

- Always keep the glass surface clean.
- Please affix the necessary identifications according to local traffic laws, rules and regulations. Do not stick paper or hang objects on the surface of the front windshield glass, otherwise the front view will be obstructed, which may easily cause traffic accidents.

4.3.5 Rearview mirror

Interior rearview mirror

Automatic anti-dazzling interior rearview mirror*

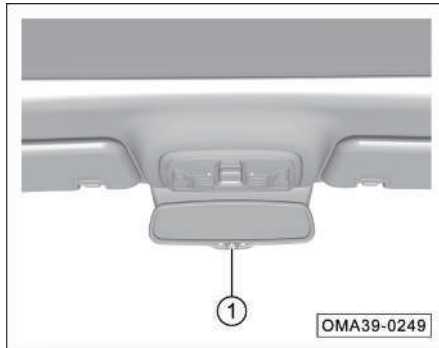

The automatic anti-dazzling interior rearview mirror uses the light sensor to monitor the light in front and rear of the vehicle, and reduces the glare reflected off the mirror surface, thus realizing the optimal rear view.

- When the ENGINE START/STOP button is in "ON" position, the auto dimming function will be automatically activated and the switch indicator lamp will come on. Press the switch ① to manually activate or deactivate this function. When this function is deactivated, the switch indicator lamp will go out.

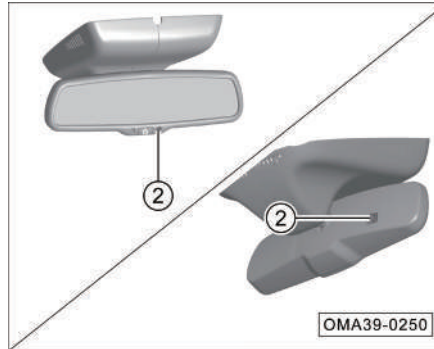

CAUTION

Do not cover the light sensor ② so as not to affect its normal function.

NOTE

If the indoor temperature is low, the anti-dazzling rearview mirror may take a longer time to reduce the glare.

Manual anti-dazzling interior rearview mirror*



Manually adjusting the manual anti-dazzling interior rearview mirror can reduce the light reflected off the mirror surface, thus realizing the optimal rear view.

- As shown in the figure, the tab is at a normal rearview position. Push it backward to offset the light reflected off the mirror surface to achieve the anti-glare purpose.
- Pull the tab forward to return to the normal rearview angle.

4. Operation of systems and equipment

Exterior rearview mirror

WARNING

Although the curved (convex and spherical) rearview mirror can expand the field of view, the reflected object image is smaller and farther than the real object. Therefore, when changing the lanes, do not judge the distance between your vehicle and the following vehicle by the reflected image, otherwise accidents may occur due to wrong judgment.

NOTE

If the function of the exterior rearview mirror fails, please go to the GAC Motor authorized shop for inspection in time.

Electric adjustment

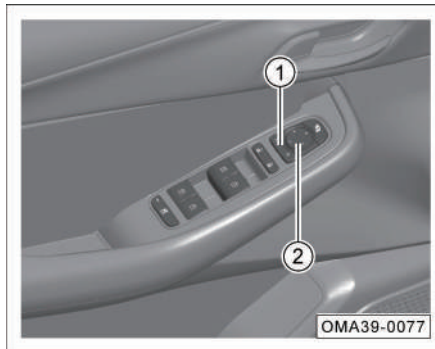

- Press “L” or “R” end on the selection button ① to select the left or right exterior rearview mirror.
- Press the adjusting button ② to adjust the selected exterior rearview mirror to the appropriate rearview angle.
- After adjusting the exterior rearview mirror, restore the selection button ① to its original state.

Electric folding*

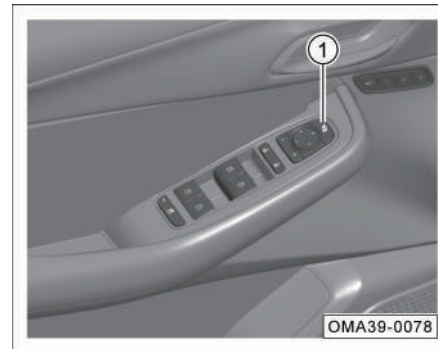

- Press the folding button ① to fold the exterior rearview mirror electrically.
- Press the folding button ① again to unfold the exterior rearview mirror electrically.

Automatic folding*

- If the vehicle is locked from outside, the exterior rearview mirror will be folded automatically.
- If the vehicle is unlocked from outside, the exterior rearview mirror will be unfolded automatically.

4. Operation of systems and equipment

CAUTION

- If the exterior rearview mirror does not feature the electric folding function or the electric folding function fails, the mirror can be manually folded and then manually unfolded. A click can be heard when the mirror is manually unfolded.
- Be careful when operating the electric folding function of the exterior rearview mirror to prevent your fingers from being pinched by the rearview mirror and its base.

Defogging function*

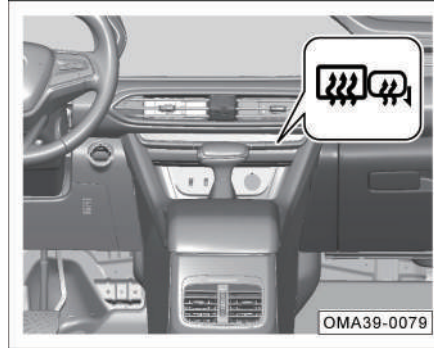

- If the button  is pulled up/pressed down, the button indicator lamp will come on, and the heating function will be activated to clear the fog or frost on the exterior rearview mirrors and the rear windshield glass.
- This function will be deactivated automatically after about 15min or pulling up/pressing down the button again can manually deactivate this function; when the heating function is deactivated, the button indicator lamp will go out.

CAUTION

- If there is residual fog or frost after the defogging function is deactivated automatically, pull up/press down the button  again.
- Do not use the defogging function for a long time, otherwise the heater may be damaged due to overheating.
- If the defrosting and defogging function is out of use, please deactivate it to avoid wasting battery power.

4. Operation of systems and equipment

4.3.6 Sun visor

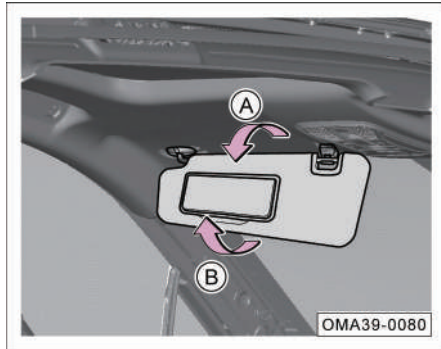

- Turn down the sun visor on the driver's side or front passenger's side in the direction of arrow A to shelter from the incoming sunlight from the front windshield.
- To use the vanity mirror, just turn down the sun visor and pull open the vanity mirror cover in the direction of arrow B, and then the vanity mirror lamp* comes on automatically.

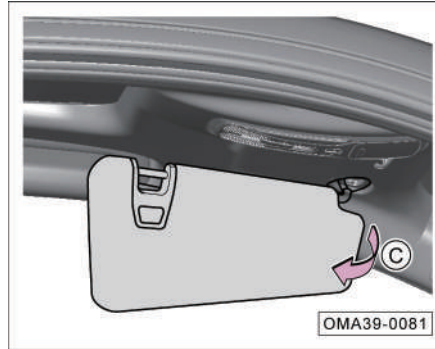

- After turning down the sun visor on the driver's side or front passenger's side, pull it out from the movable bracket in the direction of arrow C to shelter from the incoming sunlight from the side window.

i NOTE

With the ENGINE START/STOP button set to "OFF" position, after the vehicle has been locked for a few minutes, the vanity mirror lamp* will go out automatically.

4.4 Seats and storage facilities

4.4.1 Head restraints

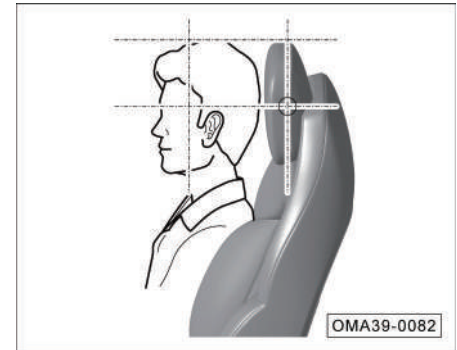

Correct adjustment of the head restraints is essential to protect the occupants and reduce the personal injuries in accidents.

All occupants must adjust the head restraints to the correct position (as shown in the figure) according to their body shape.

4. Operation of systems and equipment

WARNING

In order to reduce the risk of accidental casualties, please strictly observe the followings:

- Do not adjust the head restraint while driving.
- Driving with the headrest removed is prohibited. If the headrest is removed or installed improperly during driving, the heads of the driver and passengers will not be effectively protected in case of an accident.

Height adjustment of front seat head restraint



- Downward adjustment: Press and hold the lock button, and press down the head restraint to the desired position.
- Upward adjustment: Lift up the head restraint directly to the desired position.

NOTE

The adjustment method of other seat head restraints is the same.

4.4.2 Front seats

NOTE

When measuring the depth of the seat cushion, be sure to adjust the front and rear positions of the seat to the middle of the slide rail and the seat back to the normal operating state (25°).

WARNING

- Do not place objects under the front seats, for these objects may be caught between the seat and the slide rail, hindering the seat from being locked.
- Never adjust the front seat during driving.
- During horizontal adjustment of the seat, pay attention to the distance at the front and rear to avoid personal injury due to excessive adjustment.
- Never leave children alone in the vehicle to prevent them from accidentally operating the power seat and causing accidents, because the power seat* adjustment mechanism still works after the ignition switch is turned to the “OFF” position.

4. Operation of systems and equipment

Power seat*

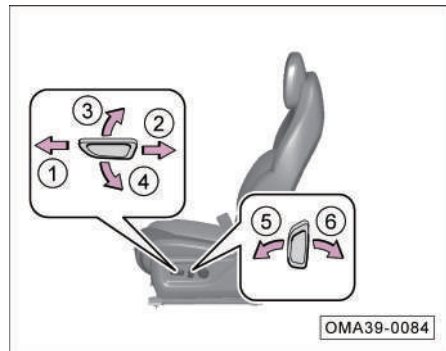

Forward and backward adjustment of seat:

- Push the switch in the direction of arrow ① or ② to adjust the seat to slide forward or backward.

Upward and downward adjustment of seat (for driver's seat)*:

- Pull the switch in the direction of arrow ③ or ④ to adjust the seat upward or downward.

Forward and backward adjustment of seat back:

- Pull the switch in the direction of arrow ⑤ or ⑥ to adjust the seat back to slide forward or backward.

Adjustment of driver's seat lumbar support*

图片有误需重新提供

- Press the switch in the direction of arrow ①, ②, ③ or ④ for upward and forward support, and downward and backward retraction respectively.

Manual seat

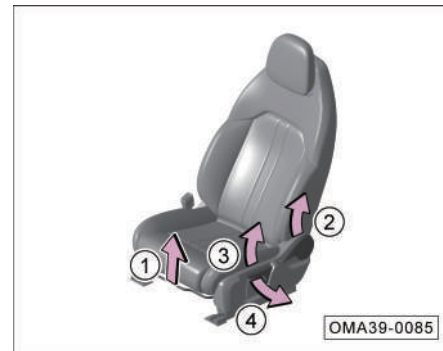

Forward and backward adjustment of seat:

- Pull the adjusting handle in the direction of arrow ① to adjust the seat to slide forward or backward. Then release the adjusting handle, and slide the seat forward or backward slightly until the seat is firmly locked.

Forward and backward adjustment of seat back:





- Pull up the adjusting handle in the direction of arrow ② to adjust the seat back to a desired position, and then release the handle.

Upward and downward adjustment of seat (for driver's seat)*:

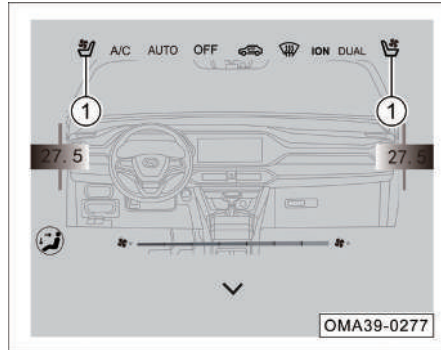

- Pull the switch in the direction of arrow ③ or ④ to adjust the seat upward or downward.

Seat ventilation*



- Switch the engine start/stop button to the "ON" position.
- Switch the AV system to the A/C control interface, and click the  or  soft key ①. Then the soft key indicator lamp comes on, and the corresponding seat is started to be ventilated.
- When there is only 1 indicator lamp of soft key, clicking the  or  soft key ① can directly deactivate the ventilation function, and then the soft key indicator lamp will go out.

The seat ventilation system has three positions, corresponding to three different ventilation speeds, among which the 3rd position has the highest ventilation speed followed by the 2nd position, and the 1st position has the lowest ventilation speed. Each press on the soft key changes the position of the system once, in the sequence of "0→3→2→1→0". The number of lit soft key indicator lamps changes accordingly.

If you press the  or  soft key during the automatic ventilation process, the automatic ventilation function will be deactivated and the system will change from the current position to the next position.

i NOTE

- The seat ventilation switch has no physical button and also no display on the main interface of the AV system. You need to click on the A/C status display area in the lower left/right corner of the AV system interface to enter the A/C control interface for adjustment.
- This function can be activated or deactivated via "Vehicle Settings → Seat Settings → Automatic Ventilation" of the AV system.

4.4.3 Rear seats

Folding down of rear seat back

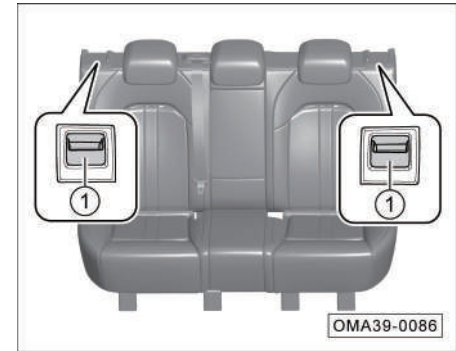

- Fold down: Pull the rear seat back switch ① forward, and recline the rear seat back forward to the limit position.
- Restore: Push the rear seat back directly backwards until the seat back is locked, and at the same time arrange the seat belt into the seat cushion groove, and finally lay the seat cushion flat.

4. Operation of systems and equipment

i NOTE

- The rear seat angle may also be adjusted by the rear seat back switch ①.
- Before the seat is turned to the seating position, the seat belt buckle should be taken out to prevent it from falling under the seat cushion.

Rear center console armrest*

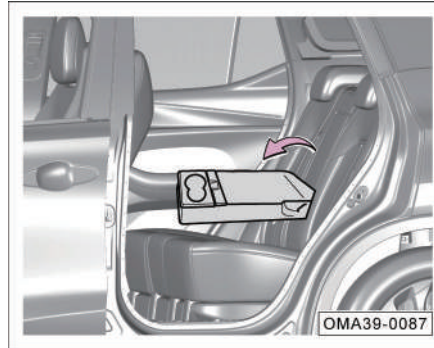

- Turn down the center console armrest to use it.

i NOTE

The center console armrest shall not be seated by anyone, and shall return to the seat back if the rear middle seat needs to be occupied.

4.4.4 Storage facilities

Storage compartment on door interior trim panel

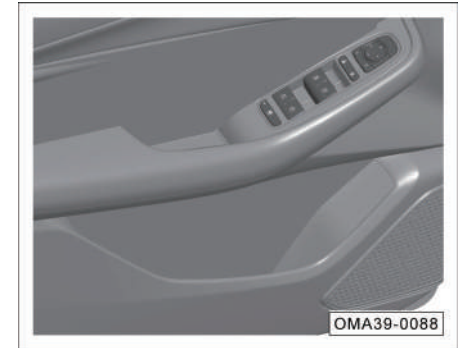

- Place beverage bottles, map manuals and other articles here.

4. Operation of systems and equipment

Storage box on lower protective plate of cab



- Open the storage box on lower protective plate of cab as arrowed to place small articles.
- Push back to close the storage box until you hear a “click” sound.

Instrument panel storage compartment

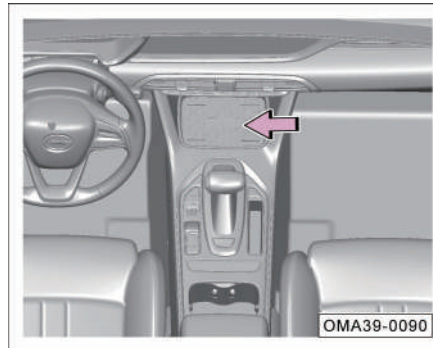

- Place small articles here.

i NOTE

For models equipped with mobile phone wireless charging function*, this area is used as the mobile phone wireless charging area, so be sure to deactivate the mobile phone wireless charging function before placing articles in it.

Cup holder

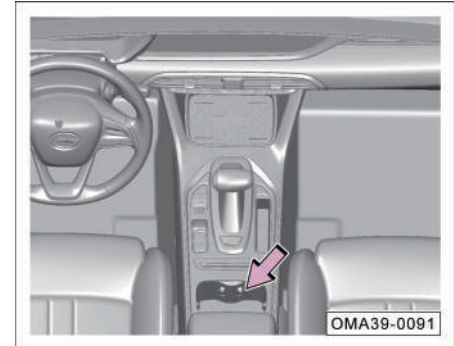

- Front cup holder: Place beverage bottles here.

i NOTE

The button area is not waterproof. The front cup holder should be kept stable when placing drinks, ensuring no splash near the button and preventing damage to internal electronic devices.

4. Operation of systems and equipment

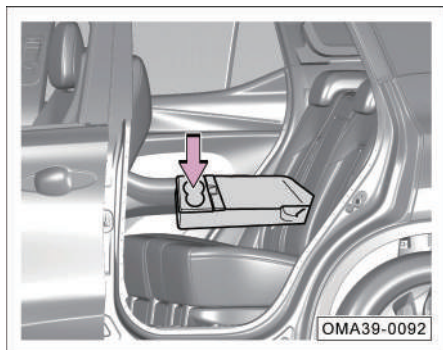

- Rear cup holder: Turn down the center console armrest forward, and then open the rear cup holder cover to place beverage bottles.

i NOTE

Do not place hot beverages on the cup holder, or hot beverages may spill out while driving, scalding the driver.

Spectacle case

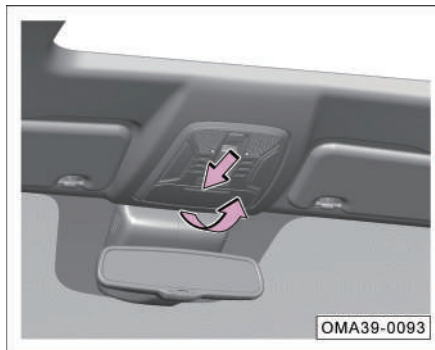

- Press to slowly open the spectacle case and place small articles such as sunglasses.
- Push back to close the spectacle case until you hear a “click” sound.

Front passenger's glove box

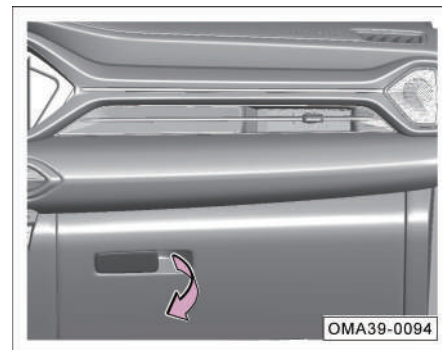

- Pull the handle to open the glove box and place articles such as file bags.
- Push back to close the glove box until you hear a “click” sound.

⚠ WARNING

During driving, the glove box must be closed, otherwise the articles in the glove box may be thrown out and cause injuries to the occupants in case of emergency braking or an accident.

4. Operation of systems and equipment

Front central armrest box

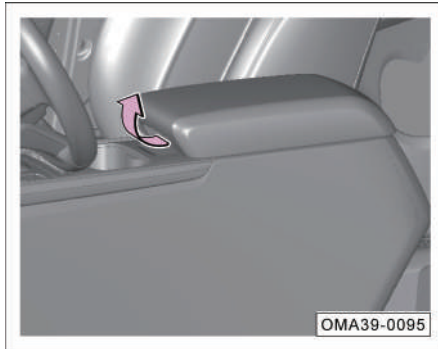

- Open the front central armrest box cover and place wallets and other articles.

Storage bag on the back of front seat



- Pull open the storage bag to place books, foldable umbrellas and other articles.

4.4.5 USB port / power outlet

Front USB port

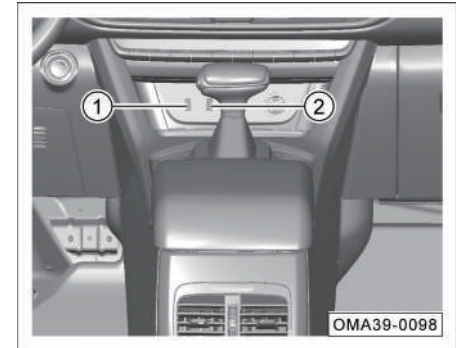

- With the ignition switch set to “ACC” or “ON” position, a mobile device can be connected.
- USB1 port ① supports charging, media playback and OTG functions.
- USB2 port ② supports charging and media playback.

4. Operation of systems and equipment

Rear USB charging port at central armrest box*



- With the ignition switch in the “ACC” or “ON” position, a device to be charged can be connected.

Front power outlet

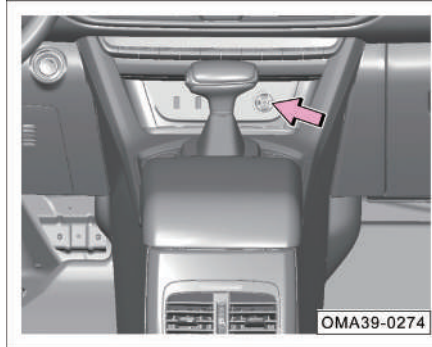

- With the ignition switch set to “ACC” or “ON” position, after the front power outlet cover is opened, a device (maximum power: 120 W) to be charged can be connected.

CAUTION

- To avoid damage to the electrical system of the vehicle, never connect power generation equipment to a power outlet.
- Only use electrical equipment that complies with national electromagnetic compatibility regulations.
- Before turning the ignition switch to “ON” or “OFF” position, always disconnect the device connected to the power outlet to avoid damage to the electrical consumer due to voltage fluctuations.

WARNING

- **Never use the power outlet when nobody is in the vehicle. Improper use of the power outlet may easily cause a fire.**
- **Do not let children use the power outlet.**
- **Never use the high-power electrical consumer.**

4.4.6 Mobile phone wireless charging system*

The mobile phone wireless charging system utilizes electromagnetic induction to realize the charging of the mobile phone without the need for wire connections.

CAUTION

The mobile phone wireless charging system applies to Qi-certified mobile phones only. GAC Motor will not assume responsibility or bear losses for any accident caused by the use of mobile phones or wireless charger receivers that have not passed the “Qi” certification.

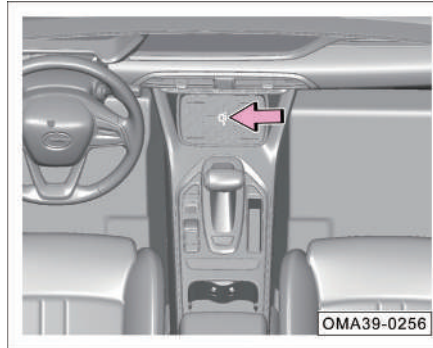

The wireless charging effective area is located in the instrument panel storage compartment. To charge the mobile phone, please align its charging coil with the “Qi” logo to ensure the normal charging.

Mobile phone wireless charging switch

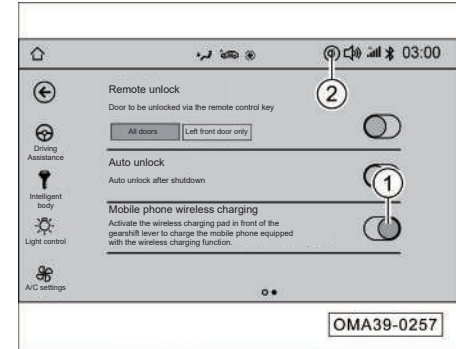



When the ignition switch is in the “ON” position, enter “Vehicle Settings → Intelligent Body → Mobile Phone Wireless Charging” in the AV system:





- Click the slider ① to turn on or off the mobile phone wireless charging system.

4. Operation of systems and equipment

i NOTE

- After the mobile phone wireless charging system is turned on, the icon  will be displayed at the position  on the interface. The icon status will change as the mobile phone wireless charging system is used. If you click the icon, the corresponding text message will pop up.
- When using the mobile phone wireless charging function, make sure that the doors are closed, because the opening of the door will deactivate the charging function.

Symbol status

Symbol	Color	Status	NOTE
	White	Standby	The wireless charging function is activated. Please use the Qi-certified mobile phone
	Green	Being charged	Click the symbol to display "The phone is being charged"
	Green	Fully charged	Click the symbol to display "The phone is fully charged"
	Red	Charging failure	Click the symbol to display related failure information. See "Mobile phone wireless charging failure" table

Mobile phone wireless charging failure

Symptom	Troubleshooting
The internal temperature of the wireless charging module is too high.	The temperature is too high, so please move away the mobile phone and make another attempt later.
There are metallic foreign materials in the wireless charging module area, or the mobile phone is placed improperly	There are metallic foreign materials. Please clear the foreign materials or relocate the mobile phone
The power supply voltage of the wireless charging module is too low or too high.	The voltage is abnormal, so please move away the mobile phone and make another attempt later.
The mobile phone request charging power is too high, or the wireless charging module transmitting power is too high.	The power is abnormal, so please move away the mobile phone and make another attempt later.
The mobile phone status is abnormal.	The charging is interrupted, so please move away the mobile phone and make another attempt later.

4. Operation of systems and equipment



WARNING

- **Please do not place anything between the mobile phone and the charging pad during the charging. Non-metallic articles may cause the charging performance degradation. Magnetic cards, chip cards or other similar articles may be damaged. Metal foreign materials such as keys and coins may be heated, causing hidden driving safety hazards.**
- **To place metal foreign materials in the mobile phone wireless charging area, please first deactivate the wireless charging function through the menu of AV system to prevent the metal articles from being heated in the charging area, which may cause hidden safety hazards.**
- **When the driver is not in the vehicle, please do not charge the mobile phone in the vehicle to avoid accidents.**
- **During driving, do not check the charging status of your mobile phone for a long time to avoid traffic accidents.**



CAUTION

- Do not spill water in the armrest box to prevent any damage to the electronic components due to water entering the wireless charging module.
- Please do not place heavy objects in the charging area to avoid damage to the mobile phone wireless charging system.
- If the product is faulty and cannot be used normally, please stop using it and go to the GAC Motor authorized shop for inspection in time.
- If there is any metal foreign material between the mobile phone and the charging area during the wireless charging, do not remove the foreign material immediately by hand to avoid scalding. Instead, deactivate the wireless charging function immediately, and wait until the foreign material is cooled down and then remove it.



NOTE

- GAC will not assume responsibility for any problem caused by abnormal use (such as the use of external wireless charging coil); if the product is disassembled or modified without any authorization, the free warranty service will be terminated.
- Only charge one mobile phone at a time.
- On bumpy roads, the mobile phone wireless charging function may be intermittently discontinued and continued. If the mobile phone deviates from the charging area and stops being charged, please move the mobile phone back to the charging area.
- In order to ensure the normal charging of the mobile phone, please try to ensure that the center of the mobile phone is aligned with the Qi logo in the front storage box.
- Opening the door will interrupt the charging, so please make sure all doors are closed when charging.

4. Operation of systems and equipment

NOTE

- The wireless charging function involves both the vehicle and the mobile phone, and if either of them is faulty, charging failure may occur.
- The charging of the mobile phone may be discontinued when the temperature is too high, and will be continued after the temperature decreases.
- When the mobile phone wireless charging function is activated, the intelligent remote control key should be far away from the wireless charging area, otherwise the detection of the intelligent remote control key will be affected.

4.4.7 Trunk

In order to ensure the maneuvering stability of the whole vehicle, the luggage shall be placed as evenly as possible, and the heavy objects shall be placed at the front of the trunk.

WARNING

- **The center of gravity of the vehicle carrying heavy objects may change. If the heavy objects in the trunk suddenly slip, the maneuvering stability of the vehicle will change.**
- **The articles in the trunk must be fixed, otherwise they may fly forward and cause personal injury to the occupants in case of an emergency braking or an accident.**
- **Never place fragile, flammable and explosive articles in the trunk!**

Trunk volume

- Fold down the rear seat back to increase the trunk volume. => [See page 93](#)

CAUTION

When placing liquids in the trunk, make sure that the container is sealed and the liquid does not leak. Avoid placing liquids on the seat back folded down to prevent wet seat due to liquid leakage.

4. Operation of systems and equipment

Objects in trunk

First aid kit

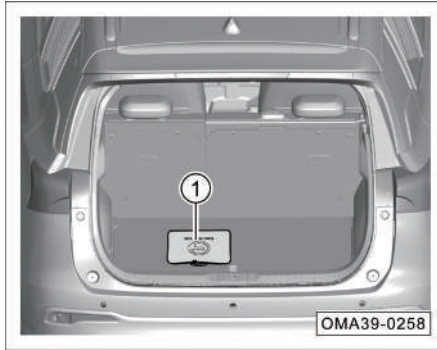

- The first aid kit ① is placed in the trunk.

Carpet

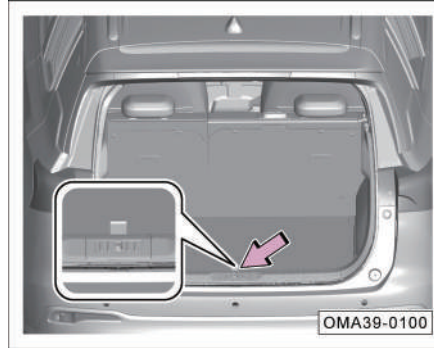

- Lift the carpet with the pull cord.

Warning triangle

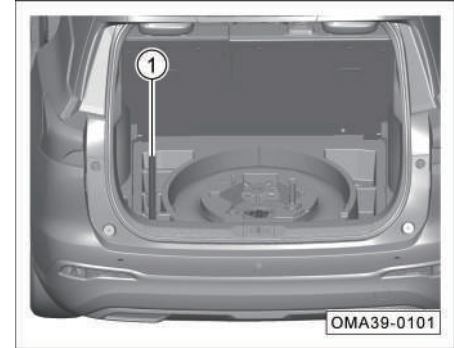

- Lift the carpet with the pull cord.
- There is a warning triangle ① in the trunk storage box.

4. Operation of systems and equipment

Driver's tools/spare tire

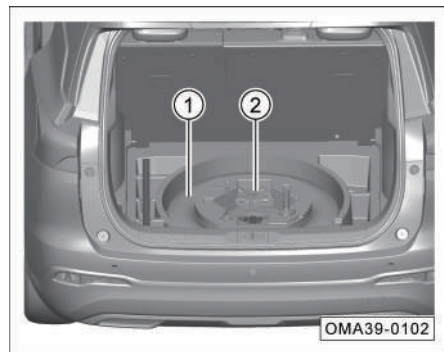

- Lift the carpet with the pull cord.
- There are driver's tools ② and spare tire ① in the trunk

Trunk security shade

Remove the security shade

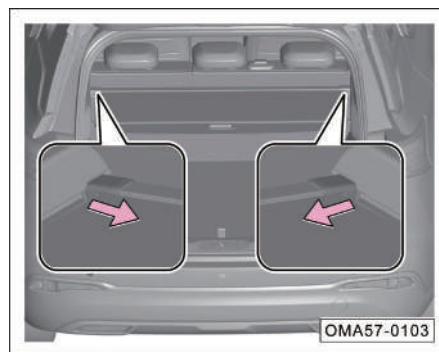

- Pull the security shade down. The security shade will automatically roll up and can be removed.

Use the security shade

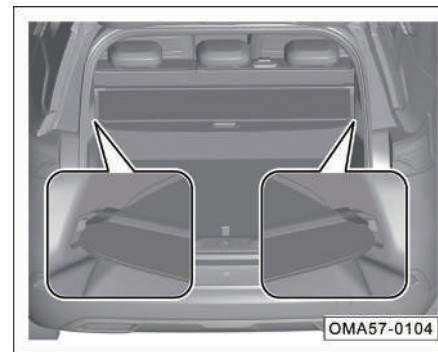

- Pull the security shade up and fix it in the grooves on both sides of the body.

 **WARNING**

It is forbidden to place objects on the security shade, otherwise they will become dangerous projectiles during emergency braking.

4. Operation of systems and equipment

4.4.8 Luggage rack



The luggage rack of this vehicle is a decorative piece and cannot be used to directly carry articles on it.

WARNING

Never place articles on the luggage rack!

4.4.9 Accessories and modification

Data labels and signs are affixed to fuel tank cap, engine hood latch and other components of the delivered vehicle, which indicating important data and information about the use of the vehicle. Do not remove or damage these labels and signs, and always keep the data and information on them legible.

The vehicle is designed with the latest safety technologies by GAC to ensure excellent active safety and passive safety. Therefore, in order to maintain the excellent characteristics of this vehicle, please be sure to consult the GAC Motor authorized shop before installing accessories or replacing parts.

The accessories and parts approved by GAC are recommended for you. The parts other than GAC ones will not be covered by the warranty.

WARNING

The installation of inappropriate accessories or the modification of the vehicle may affect the maneuvering stability and other performance of the vehicle, and even may cause serious casualties.

To install a car phone, alarm device, transceiver, low-power AV system, etc., ensure that they will not interfere with the electronic control unit such as anti-lock braking system (ABS) and tire pressure monitoring system (TPMS) on the vehicle.

4. Operation of systems and equipment

Before installing the accessories, please ensure that:

1. The accessories neither dim the lamps, nor affect the normal operation or performance of the vehicle.
2. For the vehicle equipped with side curtain airbags, do not install accessories on the B-pillar or across the rear door window. This is because the installation in these areas will interfere with the normal function of the side curtain airbags.

NOTE

When additions (such as head restraint, seat cover, floor mat, sun protection mat, etc.) are required, inferior additions may contain VOCs that do not meet national standards, and may emit unusual odors, causing hidden dangers that affect the air quality in the vehicle; therefore, the genuine high-quality additions are recommended to ensure a comfortable driving environment.

Modification of vehicle

Dismantling the parts from the vehicle or replacing the genuine parts with non-GAC Motor parts will seriously damage the maneuvering stability and reliability of the vehicle. For example:

- The installation of larger or smaller wheel and tire will interfere with the normal operation of the anti-lock braking system (ABS) and other systems.
- The modification of the steering wheel and other safety devices may cause the system failure.

WARNING

- **Improper modification of the vehicle or installation of inappropriate accessories may easily cause failures and accidents. The accessories and parts approved by GAC are always recommended, because the adaptability, reliability and safety of these accessories and parts have been strictly verified by GAC.**

WARNING

- **Improper modification or maintenance of the vehicle may weaken the protective effect of the airbag, resulting in the system failures and fatal accidents. The accessories such as beverage cup holder and mobile phone holder must not be installed or connected to the cover of the airbag assembly or within the working range of the airbag.**
- **Improper operation or modification of the vehicle (such as the modification of the engine, brake system, or components that affect the performance of the wheels and tires) will affect the SRS function, causing serious casualties.**
- **Do not install wheels and tires that are not approved by GAC.**
- **The modifications of the front and the engine compartment of the vehicle may weaken the function of the pedestrian detection system and violate road traffic regulations.**

4.5 A/C system

4.5.1 General

The A/C filter can filter pollen and dust entering the air inlet of A/C system.

The A/C filter must be regularly cleaned and replaced according to “Regular Maintenance Schedule” in “Warranty Manual”.

If the vehicle is often driven in areas with poor air quality, the replacement interval of the A/C filter should be shortened. If the airflow from the A/C air outlet is not as smooth as usual, it may be due to the dirty and clogged A/C filter. In this case, clean or replace the A/C filter as soon as possible.

WARNING

If the air in the vehicle is foul, it will make the driver easily fatigued, lack of energy, and distracted, which is easy to cause an accident, resulting in personal injury or even death. Therefore, use the air circulation mode according to the actual situation.

CAUTION

If the A/C system has failure (such as no cooling, odor in outlet air, etc.), please go to the GAC Motor authorized shop for inspection.

NOTE



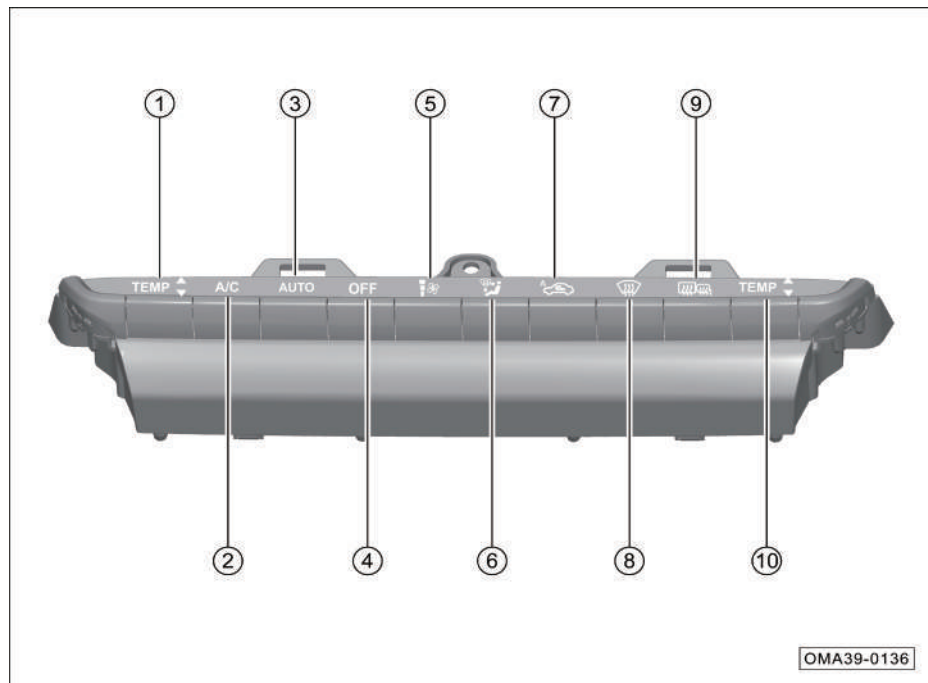

- When the ignition switch is in “ON” position, the HVAC system can be operated.
- When the A/C is turned on, there will be water dripped under the vehicle. Prolonged parking with the A/C on will cause accumulated water, which is normal.
- Regularly clean the front windshield wiper cover and remove snow, ice, and leaves to avoid clogging the A/C air inlet and ensure normal air inlet.
- The A/C system can achieve its maximum effect with the windows and sunroof closed. However, when the indoor temperature is high under hot sun, open the windows briefly to allow the indoor heat to dissipate, and then use the A/C for cooling.

4. Operation of systems and equipment

4.5.2 A/C system



Auto A/C system*





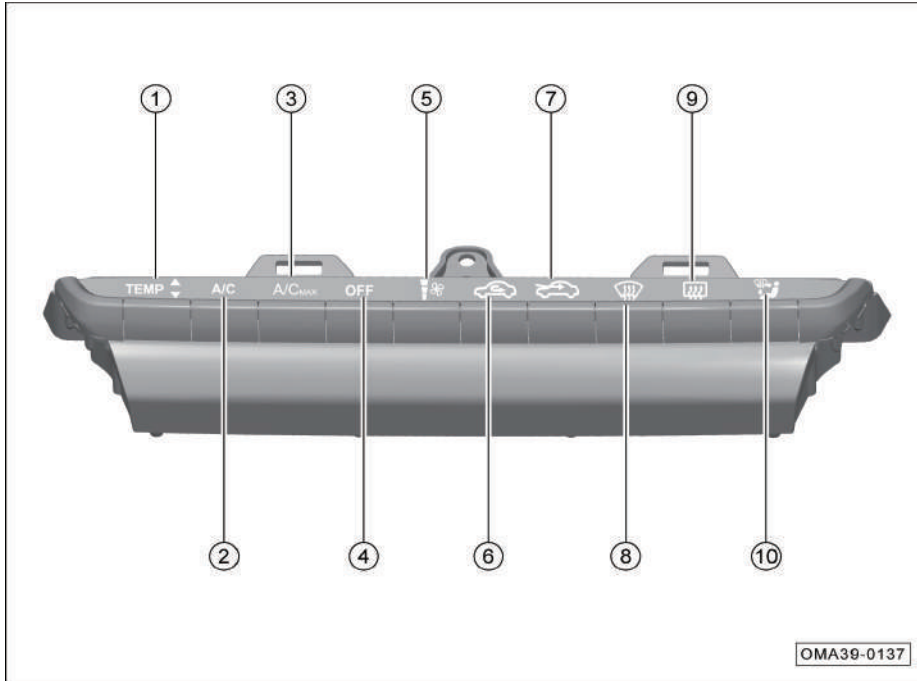

- ① TEMP ◀▶ Temperature control button (left)
- ② A/C button
- ③ AUTO mode button
- ④ OFF button
- ⑤  Air speed control button
- ⑥  Air supply mode button
- ⑦  Recirculation/fresh air mode button
- ⑧  Front windshield defrost/defog button
- ⑨  Rear windshield/exterior rearview mirror defrost/defog button
- ⑩ TEMP ▶ Temperature control button (right)

OMA39-0136

4. Operation of systems and equipment



Manual A/C system*

- ① TEMP ⇄ Temperature control button
- ② A/C button
- ③ A/C_{MAX} Negative ion button
- ④ OFF button
- ⑤  Air speed control button
- ⑥  Recirculation mode button
- ⑦  Fresh air mode button
- ⑧  Front windshield defrost/defog button
- ⑨  Rear windshield defrost/defog button
- ⑩  Air supply mode button

4. Operation of systems and equipment

NOTE

The A/C system can also be controlled by switching the AV system display interface to the A/C system control interface.

Temperature setting

- Pull up/press down the TEMP  button to increase/decrease the temperature at increments of 0.5°C.
- The temperature can be adjusted within 18.5°C~31.5°C and displayed on the AV display. When the set temperature is lower than 18.5°C, the display shows LO, and when the set temperature is higher than 31.5°C, the display shows HI.

In auto mode, when LO/HI is displayed, the system will keep high air volume.

In auto mode, in order to obtain the most satisfactory indoor temperature, it is recommended to set the temperature to 25.0°C, and adjust the temperature if necessary.

A/C button

Pull up/press down the A/C button. The button indicator lamp will come on, and the A/C system will start cooling. When the cooling function is turned on:



- There is a demand for cooling/dehumidification, but the compressor may not operate.
- When the outside temperature is below 0°C, the button indicator lamp will come on, but the compressor may not work.

Pull up/press down the A/C button again. The button indicator lamp will go out, and the A/C system will stop cooling.

Auto mode (automatic A/C)*

Pull up/press down the AUTO button. The button indicator lamp will come on, and the A/C system will enter the auto mode. The following items will be automatically controlled according to the settings:

- Outlet air temperature.
- Air volume at the air outlet.
- Air supply mode.
- Air circulation mode.
- The working state of the A/C cooling function.
- The working state of the plasma air purifier*.

Operate the  button or  button to exit the auto mode of the A/C system. The AUTO button indicator lamp will go out.

4. Operation of systems and equipment







Air speed setting

Pull up/press down the  button to increase/decrease the air speed by one level. The AV system display shows the corresponding air speed level.

In auto mode (automatic A/C)*, in order to make the indoor temperature reach the target value, the A/C system will automatically control the air speed. Operate the  button, and the A/C system will exit the auto mode.



Turn off the A/C

Pull up/press down the OFF button to turn off the A/C system.

After the A/C system is turned off, the  button,  button,  button* and  button* can be effectively operated without turning on the A/C system; operating the TEMP  button has no effect; operating the AUTO button*, A/C button,  button or  button can turn on the A/C system.

Air circulation (automatic A/C)*

Pull up/press down the  button to switch the air circulation between automatic recirculation/fresh air mode, recirculation mode and fresh air mode.

- Automatic recirculation/ fresh air mode: Pull up/ press down the  button. When the left button indicator lamp is on, the automatic recirculation/fresh air mode is activated. In this mode, the air inlet mode is controlled automatically according to the quality of outside air, the set temperature, the reverse gear signal, etc. When the quality of outside air is poor, the recirculation mode is activated; when the quality of outside air is good, the fresh air mode is activated.
- Recirculation mode: Pull up/ press down the  button. When the right button indicator lamp is on, the recirculation mode is activated. This mode prevents the outside dirty air from entering the vehicle and recirculates the inside air.



NOTE

In auto mode, the system uses the recirculation mode to optimize the cooling effect.

- Fresh air mode: Pull up/press down the  button. When all button indicator lamps are off, the air circulation enters the fresh air mode. When the quality of outside air is good, use this mode to bring the fresh outside air into the vehicle.

4. Operation of systems and equipment

Air circulation (manual A/C)*

- Recirculation mode: Pull up/ press down the  button. When the button indicator lamp is on, the recirculation mode is activated. This mode prevents the outside dirty air from entering the vehicle and recirculates the inside air.
- Fresh air mode: Pull up/press down the  button. When the button indicator lamp is on, the air circulation enters the fresh air mode. When the quality of outside air is good, use this mode to bring the fresh outside air into the vehicle.

CAUTION

- Long-term use of recirculation mode will cause accumulation of carbon dioxide in the vehicle, which is not conducive to keeping the driver awake.
- Using recirculation mode in cold or rainy weather can easily cause the windows to mist up, affecting the driver's visibility, which may cause serious accidents.

Front windshield defrost function

Press the  button. The button indicator lamp will come on, and the front windshield defrost function will be activated.

- The outlet air temperature increases.
- The A/C cooling function is turned on.
- The air supply mode is set to the defrost mode.
- The air circulation is set to fresh air mode.

Pull up/press down the  button again. The button indicator lamp will go out, the front windshield defrost function will be turned off, and the system will restore the state before defrosting; or pull up/press down the AUTO button* to enter the auto mode or turn off the front windshield defrost function.

CAUTION

- When the temperature is set to the lowest, the defrost function will cause the outer surface of the windshield to mist up, affecting the driver's visibility and probably causing serious accidents. When using the defrost function, set the temperature close to the ambient temperature outside the vehicle.
- When using the defrost/defog function, if you manually turn off the A/C cooling function, it will cause the windshield to mist up, affecting the driver's visibility, which may cause serious accidents.

4. Operation of systems and equipment

Rear windshield defrost function

Pull up/press down the  button. The button indicator lamp will come on, the rear windshield defrost function will be turned on, and the rear windshield and exterior rearview mirrors electrically heated*.

When rear windshield defrost function is working, pull up/press down the  button again. The button indicator lamp will go out, and the rear windshield defrost function will be turned off. If you do not manually turn off the rear windshield defrost function, the function will be automatically turned off after 15min.

NOTE

With the engine not started, using the rear windshield defrost function for a long time will cause too low battery voltage, making it impossible to start the engine.

Dual zone mode*

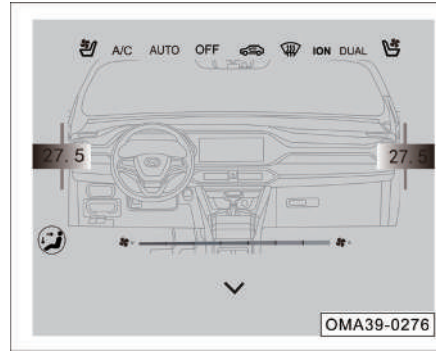

Operate the HCP control button or the A/C normal display area on the AV system display to switch the AV system to the A/C system control interface, and then click the DUAL soft key with the soft key indicator lamp on, or pull up/press down the level. The temperature control button (right), to switch the A/C system to the dual zone control mode.

In dual zone control mode, the temperatures in the left and right zones are controlled independently:





- TEMP  button (left) to set the temperature in the driver's side area.

- TEMP  button (right) to set the temperature in the front passenger's side area.

Click the DUAL soft key again. The soft key indicator lamp will go out, the A/C system will exit the dual zone control mode and enter the single zone control mode, and the temperatures in the left and right zones will be controlled simultaneously:

- TEMP  button (left) to control the indoor temperature.

Air supply mode

Pull up/press down the  button to manually and circularly select 4 air supply modes in the following order:  panel mode →  panel/floor mode →  floor mode →  floor/defrost mode.

In auto mode (automatic A/C)*, the A/C system will automatically control the air supply mode. When the outlet air temperature is high, most of the air will be directed through the floor outlets; when the outlet air temperature is low, most of the air will be directed through the panel outlets. Press the  soft key to exit the auto mode of the A/C system.

4. Operation of systems and equipment

i NOTE

- The panel/floor mode is mainly used when the outside temperature is slightly lower than the inside in spring and autumn. Therefore, the temperature of the upper outlets is slightly lower than that of the lower outlets, which is a normal phenomenon.
- The air supply mode, set temperature and comfort curve can be adjusted for personal comfort.
- In order to ensure that the A/C system can effectively control all the air supply modes automatically, please keep all air outlets open.
- During cold start in winter, in the auto mode, A/C system will start from the defrost mode and enable a gradual transition to other modes.

Plasma air purifier*

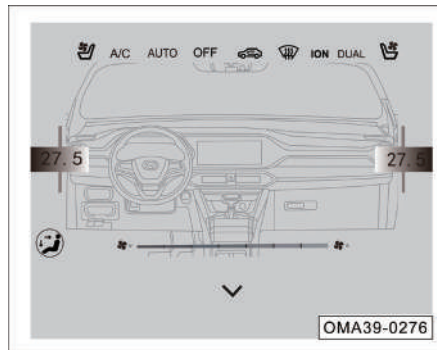

Activate the plasma air purifier to produce plasma, which can effectively decompose harmful gases such as formaldehyde and benzene in the vehicle and purify the inside air.

Operate the HCP control button or the A/C normal display area on the AV system display to switch the AV system to the A/C system control interface, and then click the soft key ION. The soft key indicator lamp will come on, and the A/C system will turn on the plasma air purifier.

Click the soft key ION again. The soft key indicator lamp will go out, and the A/C system will turn off the plasma air purifier.

4. Operation of systems and equipment

4.5.3 A/C air outlet

Panel side air outlet

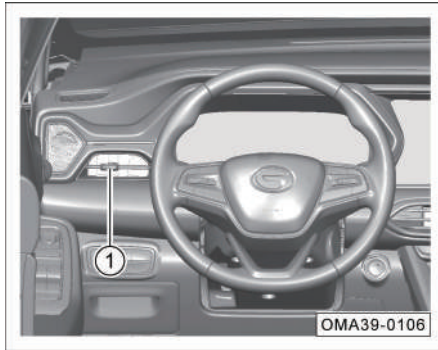

- Toggle the paddle ① up and down to adjust the air flow longitudinally.
- Toggle the paddle ① left and right to adjust the air flow laterally, or close the air outlet.

Panel center air outlet

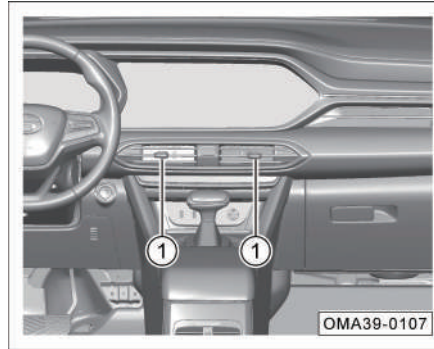

- Toggle the paddle ① up and down to adjust the air flow longitudinally.
- Toggle the paddle ① left and right to adjust the air flow laterally, or close the air outlet.

Rear air outlet

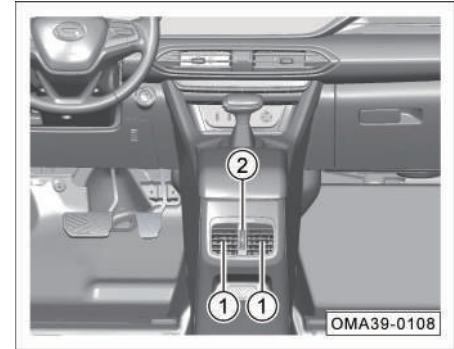

- Toggle the paddle ① up, down, left and right to adjust the air direction.
- Turn the knob ② to adjust the air volume or close the air outlet.

4. Operation of systems and equipment

4.6 AV system

4.6.1 Control panel

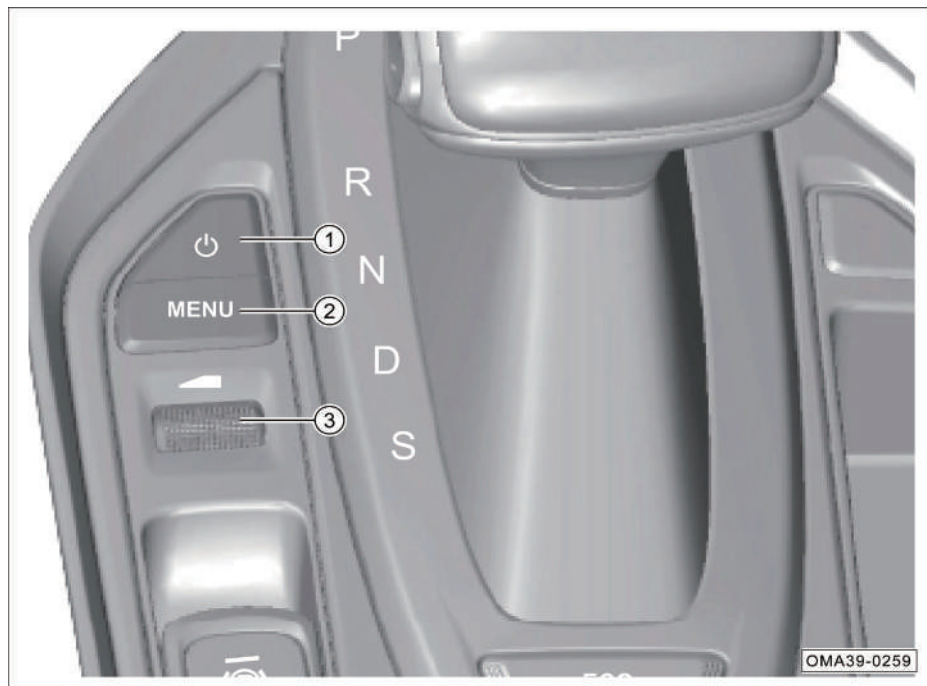

① Power button

- With power on, a short press on this button will show screensaver on the display, and the audio source does not work; another short press on this button will activate the audio source again.
- With power on, a long press on this button will turn off the display and the audio source will still work; another short press on this button will turn on the display again.

② Main interface button

- In other media interface, press this button to return to the card mode main interface.

③ Volume adjusting knob

- Turn the volume adjusting knob to adjust the sound volume.

4.6.2 Control buttons on steering wheel

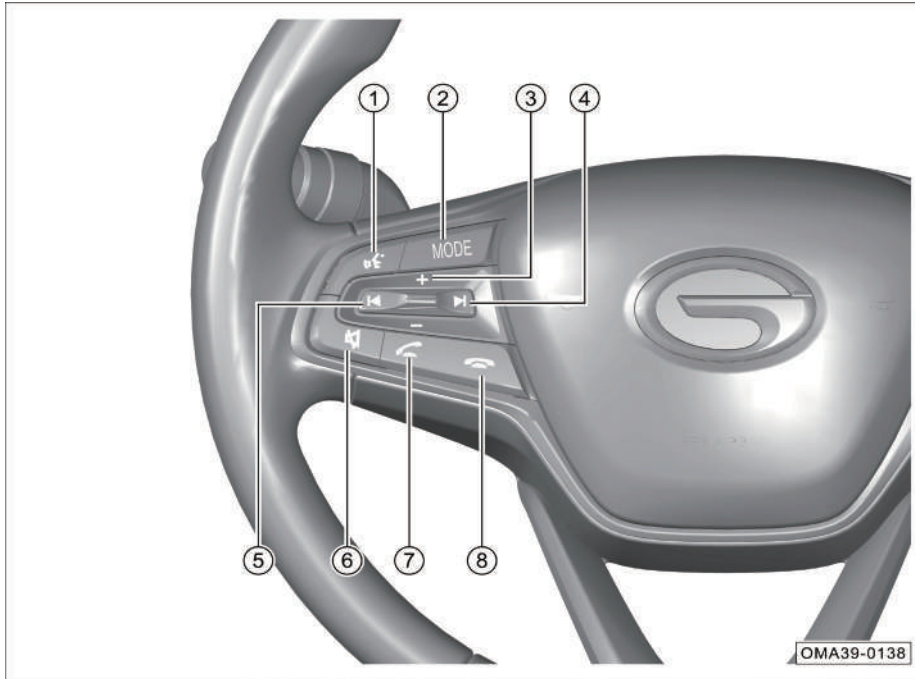

- ① Voice button
 - Press this button to activate or end the CarPlay voice.
- ② Audio source switching button
 - Press this button several times in succession to switch between the interfaces as follows: FM → AM → USB → Bluetooth music → FM.
 - Pressing this button will not actively switch to CarLife/CarPlay music; if CarLife/CarPlay music is currently playing, pressing this button will switch to radio mode.
 - Press and hold the MODE button to mute the media source.
 - Press and hold the MODE button again to unmute the media source.
- ③ Volume adjustment button
 - Toggle up/down this button to adjust the sound volume.

4. Operation of systems and equipment

④ button

- In radio mode, press this button to automatically search for a valid radio station to high frequency. If a valid radio station is found, the automatic search will be stopped and the radio station will start playing.
- When the media source is playing, press this button to skip to the next track.

⑤ button

- In the radio mode, press this button to automatically search for a valid radio station to low frequency. If a valid radio station is found, the automatic search will be stopped and the radio station will start playing.
- When the media source is playing, press this button to skip to the previous track.

⑥ Mute button

- Press this button to mute the media source.
- After that, press this button to again unmute the media source.

⑦ Answer call button

- When there is an incoming call via the Bluetooth, you can press this button to answer the call.
- When there is no incoming call via the Bluetooth, you can press this button to enter the Bluetooth Dialing interface.
- When there is no incoming call via the Bluetooth and no Bluetooth connection, you can press this button to enter the Bluetooth Settings interface.

⑧ End call button

- When there is an incoming call via the Bluetooth, you can press this button to reject the call.
- During a call, you can press this button to end the current call.



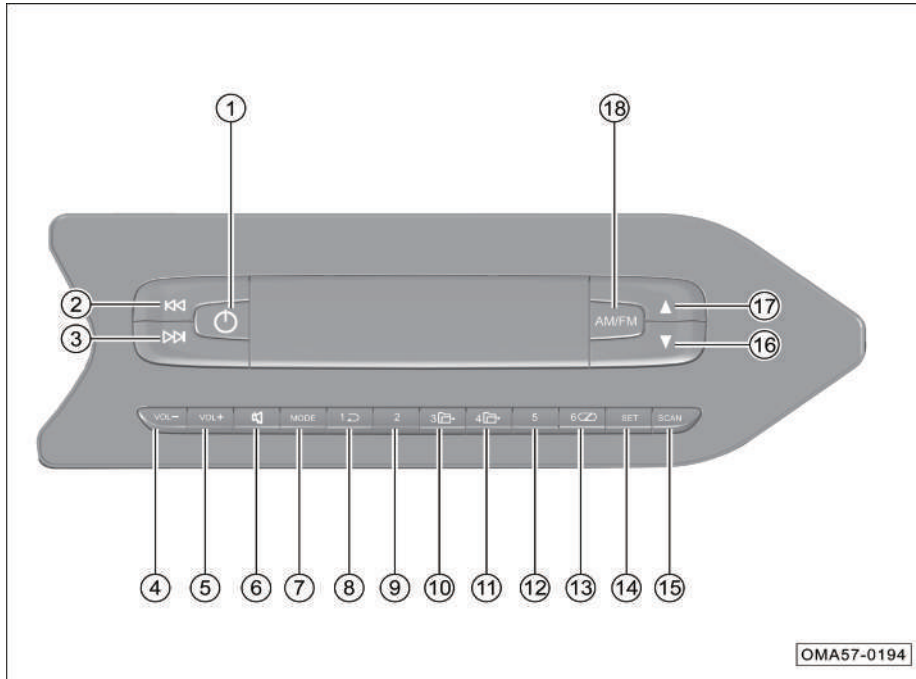

4. Operation of systems and equipment

4.6.3 Radio player*



- ① Power button
 - When the ignition switch is in ACC or ON position, press the power button to turn on the AV system.
 - When the system is on, press the power button to turn off all audio sources. At this time, the Clock interface will be displayed.
- ② Radio frequency adjusting/previous track button
 - In the Radio interface, press this button to automatically search for a valid radio station with lower frequency.
 - In the Music interface, press this button to skip to the previous track.
 - In the Music interface, press and hold this button to rewind.
- ③ Radio frequency adjusting/next track button
 - In the Radio interface, press this button to automatically search for a valid radio station with higher frequency.
 - In the Music interface, press this button to skip to the next track.

4. Operation of systems and equipment

- In the Music interface, press and hold this button to fast forward.
- ④ Press VOL- to reduce the volume.
- ⑤ Press VOL+ to increase the volume.
- ⑥  Mute button
 - In the non-mute state, press this button to enter the mute state.
 - In the mute state, press this button to unmute the sound.
- ⑦ MODE Audio source selector button
 - Press this button to switch between radio and media players.
- ⑧  Preset radio station 1 and repeat button
 - In the Radio interface, press and hold this button to store current station as the preset radio station 1, or press this button to play the preset radio station 1.
 - In the USB music interface, press this button to repeat a single track, or press and hold this button to play all tracks in the folder on repeat.
- ⑨ Preset radio station 2 button
 - In the Radio interface, press and hold this button to store current station as the preset radio station 2, or press this button to play the preset radio station 2.
- ⑩  Preset radio station 3/previous folder button
 - In the Radio interface, press and hold this button to store current station as the preset radio station 3, or press this button to play the preset radio station 3.
 - In the USB music interface, press this button to go back to the previous folder.
- ⑪  Preset radio station 4/next folder button
 - In the Radio interface, press and hold this button to store current station as the preset radio station 4, or press this button to play the preset radio station 4.
 - In the USB music interface, press this button to enter the next folder.
- ⑫ Preset radio station 5 button
 - In the Radio interface, press and hold this button to store current station as the preset radio station 5, or press this button to play the preset radio station 5.
- ⑬  Preset radio station 6 and shuffle button
 - In the Radio interface, press and hold this button to store current station as the preset radio station 6, or press this button to play the preset radio station 6.
 - In the USB music interface, press this button to shuffle all tracks, or press and hold this button to shuffle tracks in current folder.
- ⑭ SET button
 - Press this button to enter the setting interface.
 - In the setting interface, press and hold this button to exit the setting interface.
- ⑮ Scan button
 - In the Radio interface, press this button to automatically search for a valid radio station with higher frequency and play it for 10s, then continue to search for the next valid radio station and play it for 10s until the full band is completely searched.
 - In the USB music interface, press this button to scan the whole USB device, or press and hold this button to scan the folder with each track played 10s.

4. Operation of systems and equipment

- ⑩ ▼ Step-by-step down adjustment in Radio interface, and next menu option in setting interface
- In the Radio interface, press this button to manually adjust the radio station to the next frequency step by step.
 - In the setting interface, press this button to move to the next menu option.
- ⑪ ▲ Step-by-step up adjustment in Radio interface, and previous menu option in setting interface
- In the Radio interface, press this button to manually adjust the radio station to the previous frequency step by step;
 - In the setting interface, press this button to move to the previous menu option.
- ⑫ AM/FM radio button
- In other audio source modes, press this button to switch to the FM/AM radio;
 - In Radio mode, press the FM/AM button to switch between FM1-FM2-FM3-AM1-AM2 radio bands.

USB media play

USB audio source selection

Enter the main interface of USB media source in two ways:

- When the USB device is inserted in the USB slot, the display will automatically switch to the main interface of USB media source;
- In other media modes, press the MODE button to switch to the main interface of USB media source.

i NOTE

ACU supports USB devices with capacity up to 32G and formats FAT16/FAT32; the supported audio formats are MP3/WMA. Please use a high-quality genuine USB device to ensure play quality.

If no USB device is inserted, the following screen will be displayed:



When a USB device is inserted, the following screen will be displayed:



When the USB device cannot be read, the following screen will be displayed:

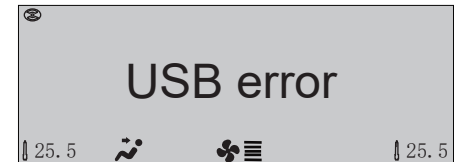

4. Operation of systems and equipment

4.6.4 Basic operation*

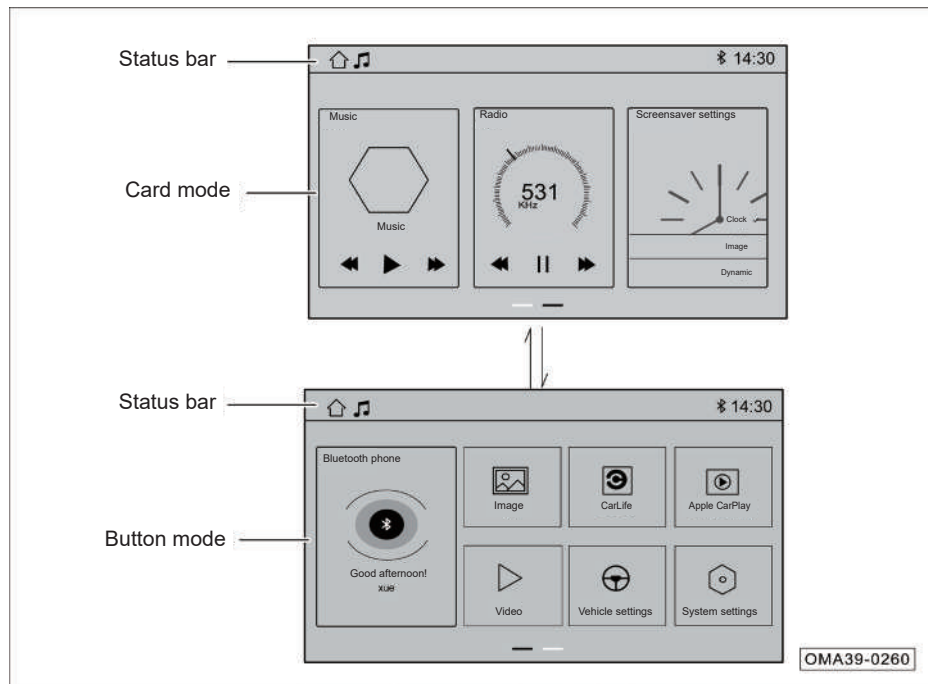

The main interface includes the card mode and button mode.

- Swipe left and right to switch between interfaces.
- Click on a card to enter the corresponding function interface; click on soft keys on this card to enable the corresponding function.
- Swipe your thumb and index finger to the center of the display from two diagonal corners at the same time to enter the editing mode, press and hold the card and drag it to edit the card sequence.
- Click on the soft key of the corresponding function in the button mode to enable the corresponding function.

i NOTE

The main interface shown is only an example of configuration. It can be used as a guide for vehicle models with an AV unit. The specific functions and interfaces depend on the actual vehicle configuration.

Time settings

- This can be set by accessing AV system “System Settings” → “General” → “Time and Date”.

Apple CarPlay

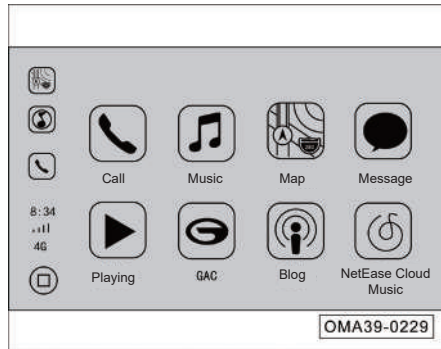

The Apple CarPlay allows you to use navigation, make calls, send and receive messages, and enjoy music while concentrating on driving.

- Connect the mobile phone to the main unit with an appropriate USB cable. If you select CarLife, you cannot connect the mobile phone to Apple CarPlay.

- After successful connection, the system will automatically switch to the AppleCarplay main interface, and the CarPlay soft key on the main interface will be highlighted.
- In other function interfaces, you can access the Apple CarPlay in-car system by clicking on the CarPlay soft key icon on the main interface.

i NOTE

- For the functions and applications supported by CarPlay, refer to the Apple's official website. According to the information released by Apple in 2019, Apple CarPlay supports iPhone5 and later.
- When using CarPlay, make sure that the CarPlay function is enabled via “Settings → General → Access Restriction” on the iPhone, otherwise the iPhone will only be used as an iPod and the Apple CarPlay will not be available.
- Please use the genuine iPhone data cable, otherwise connection failure may occur.

4. Operation of systems and equipment

4.6.5 Radio*

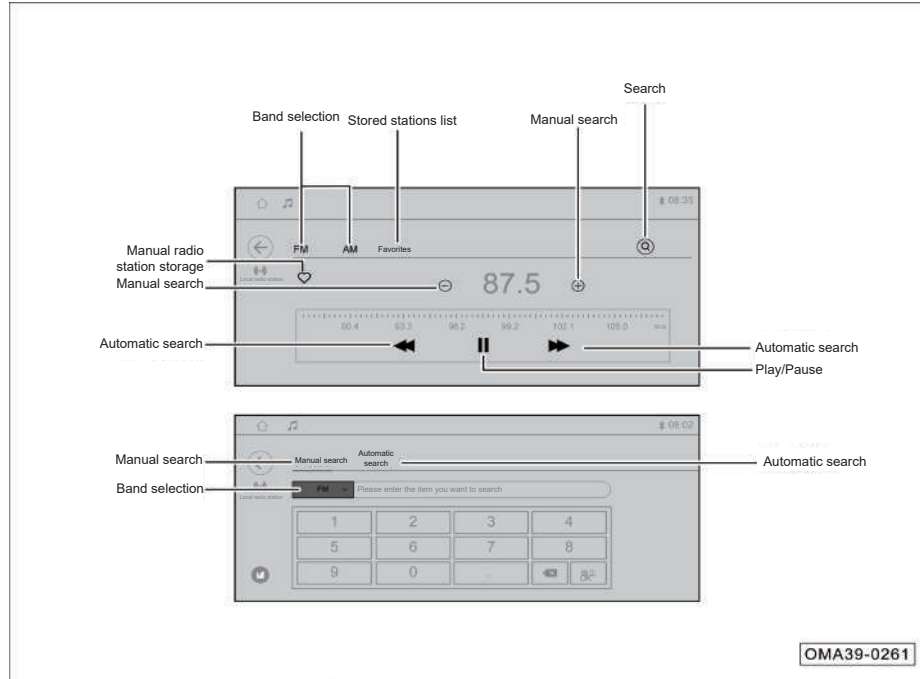

Enter the Radio interface of the AV unit in the following ways:

- Click on the “Radio” card in the card mode to enter the Radio mode.
- Press and release the MODE button on the left side of the steering wheel repeatedly to switch to the radio play.

4.6.6 USB media play

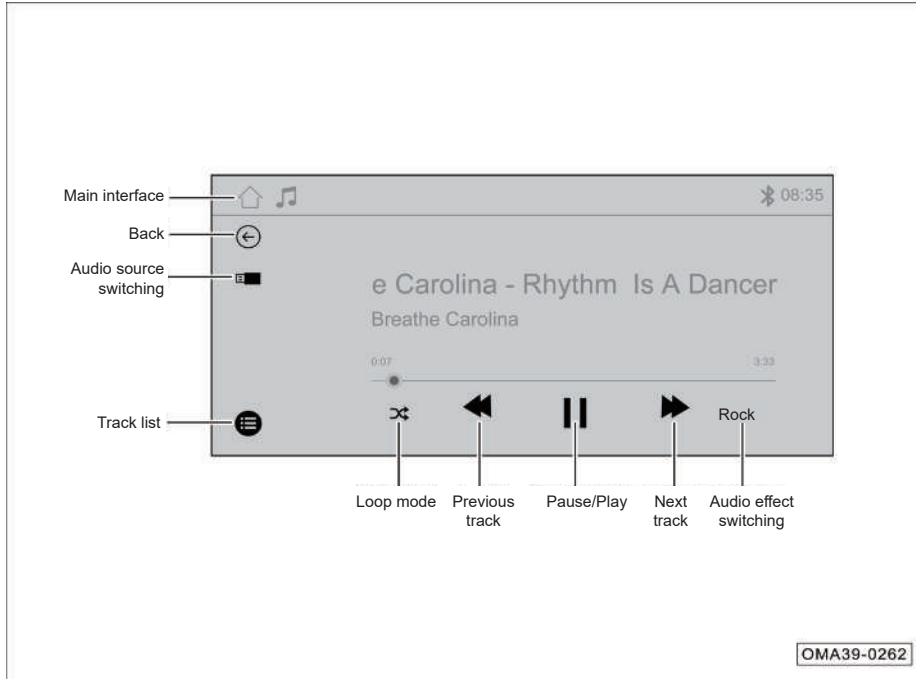

Enter the USB media play mode of the AV unit in the following ways:

- Click on the Music card in the card mode to enter the USB media play mode.
- Shortly press the "MODE" button on the left of the steering wheel consecutively to switch to the Local music mode.

i NOTE

- If the iPod function is provided, refer to the operation methods for USB.
- The maximum capacity of USB device supported by this system is 32GB, and the supported file systems of USB flash drive are FAT, FAT32 and ExFAT.

4. Operation of systems and equipment

4.6.7 Bluetooth function*

For the AV/AVNT unit, enter the Bluetooth mode in the following ways:

- Click on the "Bluetooth phone" card in the main interface to enter the Bluetooth mode.
- In non-call mode, shortly press  button on the left side of the steering wheel to enter the Bluetooth mode.

NOTE

- At most 1000 items of the contacts list of mobile phone can be downloaded.
- After the Bluetooth of the unit is activated, use your mobile phone to search for the Bluetooth device and connect it.

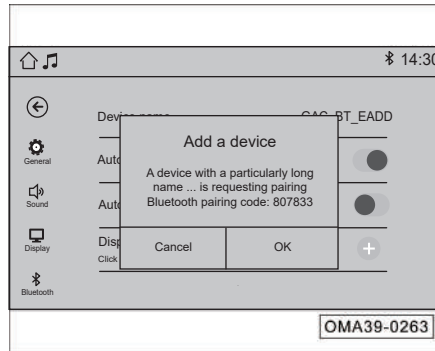

- If there is no Bluetooth device connected, use the above method to enter the Bluetooth Settings interface.
- Click the "+" soft key on the right side of the device list to make Bluetooth function visible.

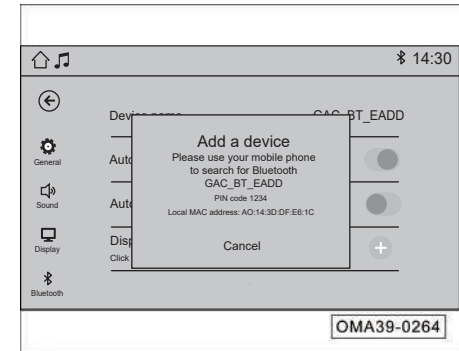

- Search for the device name on the mobile phone, and click on it to start pairing. The system receives the pairing request and then a confirmation dialog box pops up (whether the PIN code needs to be entered depends on the mobile phone model).
- Click on the "OK" soft key to start pairing; click on the "Cancel" soft key to end pairing; once the connection succeeds, the device name will be displayed in the device list.

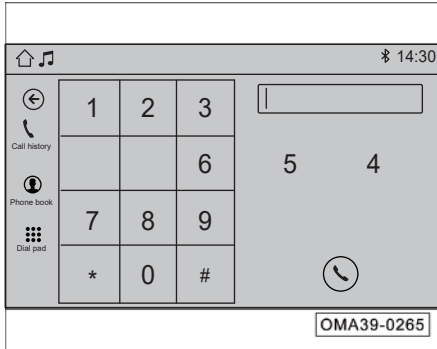

- After connecting the Bluetooth device, enter the call interface, and tap the call record, phone book and dial pad to enter the corresponding interface.
- In the main interface, click on the “Music” card to enter the media source selection interface, touch the Bluetooth icon to go to the Bluetooth music interface and use the onboard speakers to play songs on the mobile phone. If no Bluetooth is connected, the Bluetooth icon will be grayed out and cannot be clicked.

Bluetooth connection failure

Possible cause	Solution
The device's Bluetooth function is set incorrectly	Set the device's Bluetooth so that it can be “Visible to Everyone” or can be searched or opened for detection
The current device is not compatible with the in-car Bluetooth system	Confirm the compatibility of the device with the Bluetooth version, upgrade the mobile phone system to the latest version and try again
The mobile phone's Bluetooth was connected to other devices	It is recommended to delete the Bluetooth devices that were connected

4. Operation of systems and equipment

4.6.8 System settings

Click the “Settings” soft key on the main interface in the button mode to enter the system settings interface. In the settings interface, click on an option to select it, click on the slider to enable or disable the function, and drag the progress bar for adjustment.

Settings group	Function	Description	Options
General	Language*	Change display language	Chinese/English
	Time and date	Set time and date	24-hour system/manual setting time and date
	Prioritized connection to mobile phone*	Set the system to connect to CarPlay or iPod first while connecting to a mobile phone	CarPlay/iPod
Sound	Multimedia volume	Adjust the volume of radio, USB music and Bluetooth music	/
	call volume*	Adjust voice recognition/Bluetooth call volume	/
	3D sound effect	Select the optimal listening position	Off/Driver/All passengers
	Preset sound effect	Select the sound effect. If the sound effect is to be customized, it can be manually adjusted to Treble, Alto and Bass mode	Classic/Pop/Jazz/Rock/Default/Custom
	Virtual subwoofer*	Virtual subwoofer can be set when 3D sound effect is set to the Driver or All passengers mode	On/Off
	Sound field	Touch to adjust the sound field position	Reset
	Startup volume	Set the volume at startup	Unchanged/Adaptive
	Speed-sensitive volume control	Adjust the volume change rate as the vehicle speed changes	Off/Low/Medium/High
	Touch tone	Adjust the touch tone of the touch screen	Off/Modern/Retro
	Media volume during reversing	Select the volume of the AV system during reversing	Unchanged/Mute
	Door lock/unlock chime	Set chime while doors are being locked/unlocked	On/Off

4. Operation of systems and equipment

Settings group	Function	Description	Options
Display	Screen brightness	Adjust the screen brightness	/
	Brightness mode	Set the brightness mode	Day/night/auto
	A/C interface hold time	Set the time for keeping the A/C interface after no operation	5s/10s/15s/30s
Bluetooth*	Bluetooth switch	Turn Bluetooth on or off	On/Off
	Bluetooth name	Display the name of AV system Bluetooth	/
	Automatic connection*	Set whether to connect the Bluetooth device automatically	On/Off
	Auto answering	Set whether to answer calls automatically	On/Off
	Device list	Add a device to the device list	/
Factory reset	/	Restore the settings groups above to the factory defaults.	Reset

4. Operation of systems and equipment

4.6.9 Vehicle settings

Click on the “Vehicle Settings” soft key on the main interface in the button mode to enter the vehicle settings interface. In the settings interface, click on an option to select it, click on the slider  to enable or disable the function, and drag the progress bar for adjustment.

Settings group	Function	Description	Options
Seat settings*	Automatic ventilation and heating*	/	On/Off
Driving assistance	Safe speed warning (km/h)	Set the safe speed warning	Range: 0~200
	Active brake assist*	/	On/Off
	Cruise control mode*	Select the cruise control mode	Adaptive cruise control/integrated cruise assist
	FCW*	/	On/Off
	Forward collision warning distance*	Select the desired distance	Near/Medium/Far
	LKA*	/	On/Off
	LKA mode*	Select the LKA mode	Steering assist/warning/steering assist and warning
	Steering mode	Set the turning force on the steering wheel	Comfort/Standard/Sport
Intelligent body	Intelligent active door lock*	/	On/Off
	Intelligent active door unlock*	/	On/Off
	Remote unlock	Set remote door unlock	All doors/Driver's door only
	Speed sensing door lock	/	On/Off
	Auto unlock	/	On/Off
	Automatic folding of exterior rearview mirror*	/	On/Off
	Power liftgate easy open*	/	On/Off

4. Operation of systems and equipment

Settings group	Function	Description	Options
Intelligent body	Remote control windows & sunroof	/	On/Off
	Wiper*	/	On/Off
	Front wiper maintenance	/	On/Off
	Mobile phone wireless charging*	/	On/Off
Light control	Automatic headlamp sensitivity*	Select the automatic headlamp sensitivity	Low/Medium/High
	Follow me home	Select the Follow me home light mode	Off/Low beam/Low beam and rear fog lamp
	Daytime running lamp*	/	On/Off
	Intelligent courtesy lamp*	/	On/Off
A/C settings	Intelligent control of recirculation/fresh air mode*	/	On/Off
	A/C comfort curve*	Select the A/C comfort curve mode	Soft/Normal/Fast
	Air quality sensor*	Select the air quality sensor mode	Low sensitivity/Medium sensitivity/High sensitivity
	Automatic defogging*	Select the automatic defogging mode	Off/Low Sensitivity/Medium Sensitivity/High Sensitivity

4. Operation of systems and equipment

4.7 Emergency rescue

The emergency rescue function includes the automatic call after crash, which is activated automatically in some cases.

- Automatic call after crash: when the vehicle is involved in an accidental collision and the airbag is deployed, the automatic call will be activated automatically after collision to automatically call the emergency contact.

Emergency call button



① SOS button: press and hold this button (3s) to activate SOS service and call the emergency contact.

i NOTE

- Write in the mobile phone number of your designated emergency contact with your permission when the vehicle is sold.
- If you need to change the mobile phone number of the emergency contact, please go to GAC Motor authorized shop to change it.

5.1 Starting and driving

5.1.1 Ignition switch

ENGINE START/STOP button*

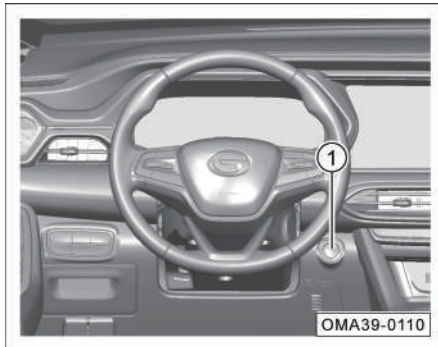

Only when the intelligent remote control key is detected in the vehicle can the ENGINE START/STOP button be operated ①.

When the gearshift lever of an AT model is in "P" or "N" position and the brake pedal is depressed, the ENGINE START/STOP button indicator lamp will turn green. At that time, press the ENGINE START/STOP button to start the engine.

With the brake pedal not depressed, press the ENGINE START/STOP button to switch the positions in the following order: "OFF → ACC → ON → OFF".

- OFF: the ENGINE START/STOP button indicator lamp goes out, and the ENGINE START/STOP button is turned off.
- ACC: the ENGINE START/STOP button indicator lamp turns orange, and the circuits of accessories such as vehicle inlet are connected.
- ON: the ENGINE START/STOP button indicator lamp turns orange, the instrument cluster backlight comes on, and the circuits of all electrical consumers are connected.

i NOTE

- If the ENGINE START/STOP button is in "ON" position, when the transmission gearshift lever is in a position other than "P" and the brake pedal is not depressed, press the ENGINE START/STOP button to switch it from "ON" position to "ACC" position. If pressed and held, it will be switched in the order of "ON → ACC → ON", rather than return to "OFF" position. With the ENGINE START/STOP button in "ACC" position, when the transmission gearshift lever is shifted to "P", the ENGINE START/STOP button will automatically return to "OFF" even if it is not pressed.
- With the gearshift lever in "P" position, when the ENGINE START/STOP button is switched from "OFF" to "ACC" and remains in "ACC" position for one hour, the vehicle will enter the battery saver mode and the ENGINE START/STOP button will automatically return to "OFF" position.

5. Driving guide

Limp home mode*



When “No key detected” appears on the instrument cluster display due to low battery of the intelligent remote control key, you can try to place the key horizontally at the mark on the bottom of the front cup holder, then press the ENGINE START/STOP button to switch it to “ACC” or “ON” position and depress the brake pedal, and after the ENGINE START/STOP button indicator lamp turns green, press the ENGINE START/STOP button to start the engine.

This method is intended for emergency start. Please replace the battery of the intelligent remote control key as soon as possible.

Conventional ignition switch*

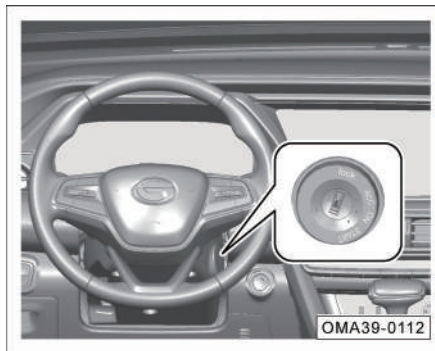

The ignition switch has 4 positions:

- LOCK (OFF): circuits are not connected and the key can be removed only in this position.
- ACC: circuits of accessories such as the vehicle inlet are connected.

- ON: the instrument cluster backlight comes on, and the circuits of all electrical consumers are connected; after the engine is started, the ignition switch will be switched to this position.
- START: this position is only used to start the engine.

i NOTE

In case of failure to turn the key from “LOCK” position to “ACC” position, the steering wheel may be turned slightly to disengage the steering wheel locking mechanism until the key can be turned to switch the position of the ignition switch.

5.1.2 Engine start

Vehicle model with a conventional ignition switch:

- Insert the mechanical key into the ignition switch.
- Make sure the gearshift lever is in the “P” or “N” position.
- Depress the brake pedal and ensure that the ENGINE START/STOP button indicator lamp turns green.
- Turn the mechanical key to switch the ignition switch to “START” position to start the engine.

Vehicle models with an ENGINE START/STOP button:

- Enter the vehicle with the intelligent remote control key carried.
- Make sure the gearshift lever is in “P” or “N” position.
- Depress the brake pedal and ensure that the ENGINE START/STOP button indicator lamp turns green.
- Press the ENGINE START/STOP button to start the engine.

NOTE

- In case of a cold start, run the engine at idle speed to warm up it before driving. At the same time, the valve tappet takes a few seconds to reach the normal working pressure and operation noise will occur, which is normal.
- Vehicle models with an ENGINE START/STOP button: if the engine cannot be started normally due to the brake signal failure, try to switch the ENGINE START/STOP button to “ACC” position. Ensure that the gearshift lever is in the “P” or “N” position, and press and hold the ENGINE START/STOP button for 15 s to force the engine to start.

CAUTION

- The engine start time shall not exceed 15s. If the engine is not started successfully, you must wait about 30s before next attempt.
- Do not depress the accelerator pedal hard to make the engine run at high speed or overload after starting. Otherwise, the engine is likely to be damaged.
- If the battery level is low and the engine cannot be started, try to start it with a jumper cable.
- It is prohibited to start the engine by pushing or towing the vehicle.

5. Driving guide



WARNING

- **Do not keep starting the engine for a long time in a poorly ventilated place or an enclosed place. The engine exhaust contains harmful gases which can make people comatose and even suffocate.**
- **Do not leave the vehicle unattended while the engine is running.**
- **Do not add a starting aid for starting the engine, as it is likely to make the engine run at high speed or cause an explosion.**

5.1.3 Engine shutdown

- Park the vehicle steady and apply the parking brake.
- Set the gearshift lever to the "P" position.
- Turn the mechanical key to switch the ignition switch to the "LOCK" position to shut down the engine.(This step is applicable to models with a conventional ignition switch.)
- Press the ENGINE START/STOP button to shut down the engine.(This step is applicable to models with an ENGINE START/STOP button.)

i NOTE

After the engine is shut down, the radiator fan may still run for a while.

Emergency shutdown (applicable to models with an ENGINE START/STOP button)

When the vehicle is running, press and hold the ENGINE START/STOP button or press it consecutively three times to switch it from "ON" to "ACC" position for emergency shutdown of the engine.

The engine can only be restarted in a few seconds after emergency shutdown. Restart the engine as follows:

- After setting the gearshift lever to "P" or "N", press the ENGINE START/STOP button to start the engine.



WARNING

Emergency shutdown is forbidden during normal driving, as it is likely to lead to vehicle damage, safety and power steering failure, and traffic accidents.

Precautions for parking

When parking the vehicle, set the gearshift lever to “P” or “N” position, and pay attention to the following:

- Pay attention to the direction when the vehicle is parked, for fear of damage to the green belt due to the exhaust gas spraying on the plants.
- Try to park on a flat and straight road, instead of a steep slope.
- For parking on a slope, regardless of whether the vehicle is facing the top or bottom of the slope, the front wheels should be turned towards the curb.
- Apply the parking brake, shut down the engine, and turn off all lamps and electrical consumers.
- When leaving the vehicle, be sure to take away your valuables and the key, and check that the sunroof, windows, doors and liftgate are closed and locked.

⚠ WARNING

- **When leaving the vehicle, be sure to shut down the engine, apply the parking brake and take away the key.**
- **Do not leave any person in the vehicle. Otherwise, suffocation, coma and even death can easily occur in the closed space.**
- **Do not park near flammable and explosive materials.**

5.1.4 Gear description

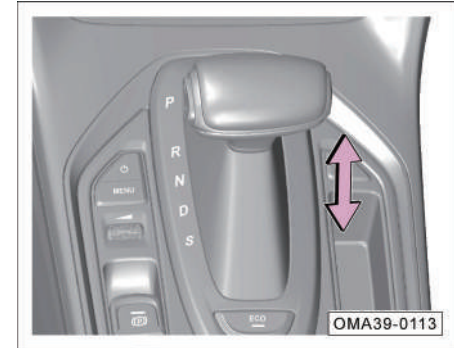

There are “P→R→N→D→S” positions. When the ignition switch is in “ON” position and the gearshift lever is set to a position, the corresponding indicator lamp on the shift panel will come on and the instrument cluster will display the corresponding gear.

5. Driving guide



WARNING

Do not shift the gearshift lever to “R”, “N” or “P” during forward driving, otherwise the transmission may be damaged or even an accident may occur.

P: Parking position

- When the vehicle is stationary, press the unlock button in the front of the gearshift lever to set the gearshift lever to “P” position.
- Depress the brake pedal and press the unlocking button in the front of the gearshift lever to move the gearshift lever out of “P” position.



CAUTION

After set to “P” gear, the gearshift lever is locked. Do not pull the gearshift lever hard, for fear of damaging the vehicle.

R: Reverse position

- When the vehicle is stationary, depress the brake pedal, and press the unlock button in the front of the gearshift lever to set the gearshift lever to “R” position.
- Release the brake pedal and slowly depress the accelerator pedal to reverse the vehicle.



CAUTION

When the gearshift lever is set to “R”, make sure that the vehicle is stopped completely and the engine speed is not high, otherwise the transmission may be damaged and even an accident may occur.

N: Neutral position

- Depress the brake pedal and press the unlocking button in the front of the gearshift lever to set the gearshift lever from “P” to “N” position.
- Directly put the gearshift lever in the “N” position to set the gearshift lever from “R” or “D” position to “P” position
- Depress the brake pedal to set the gearshift lever from “N” position to “P” or “R” position; when the gearshift lever is about to be set to “D” position, it is unnecessary to depress the brake pedal.



WARNING

Do not make the vehicle coast with the gearshift lever in “N” position. Otherwise, it is likely to cause an accident.

D: Forward position

The gearshift lever is usually set to this position during normal driving.

- Set the gearshift lever directly from “N” to “D”. With the gearshift lever in this position, the system will automatically upshift or downshift according to the engine load and vehicle speed.
- Set the gearshift lever directly from “S” to “D”.

S: Forward position

The “S” position is for sport mode. When the gearshift lever is set to this position, the transmission will shift into a lower gear according to the changes in resistance (for example, towing, climbing a long slope, etc.), and the engine will run at a higher speed to provide more power. The “S” position is mainly intended for driving with high power and also for hill driving, which can avoid frequent gear shifting.

Driving mode*



When the ignition switch is in “ON” position, press the ECO button to enter the ECO mode.

ECO mode

When the vehicle enters the ECO mode, both the transmission control unit will adopt the fuel economy shift strategy, and the A/C system will adopt the corresponding economy strategy.

i NOTE

- When the vehicle enters the ECO mode, the “ECO” indicator lamp on the instrument cluster comes on.
- ECO mode can be entered when the gearshift lever is in either of “P”, “R”, “N”, “D” positions, but only active in “D” position.
- ECO mode has a memory function. When the engine is shut down and restarted, the transmission is still in the ECO mode.

5. Driving guide

M mode

M mode is the manual mode. When the gearshift lever is in "S" position, press "+/-" on the side of the gearshift lever for upshift/downshift. At this time, the transmission enters the manual mode. When the transmission is in this mode, the driver can have more enjoyable driving pleasure according to the road conditions and driving habits.

i NOTE

When the gearshift lever is in "D" position, the driver can directly press the "+/-" button on the side of the gearshift lever to achieve manual intervention for upshift/downshift. If there is no other intervention in 5s, the original mode will be restored.

Unlock the gearshift lever

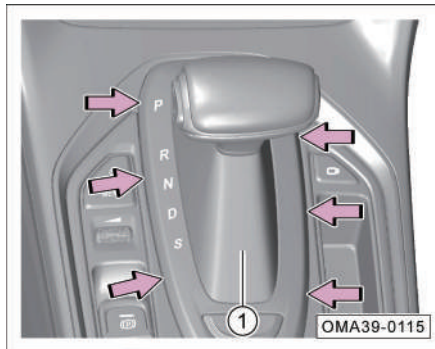

When the gearshift lever is in "P" position, locked and cannot be shifted out of "P" position normally due to battery failure or other reasons, it is necessary to unlock the gearshift lever to shift out of "P" position.

- Turn off the ignition switch.
- Carefully pry off the gear shift cover ① in the arrowed direction.

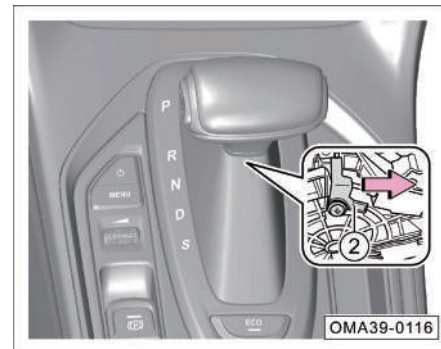

- Push the lock switch ② in the arrowed direction to unlock it, and at the same time, press the unlock button in the front of the gearshift lever, then set the gearshift lever from "P" to "N".
- Install the gear shift cover.
- Depress the brake pedal, start the engine, and check that the gearshift lever resumes normal gear operation.

CAUTION

If the gearshift lever is locked and cannot be switched out of “P” position normally, it can be unlocked by this method. If this fault occurs, there may be some problems with the vehicle. Please contact the GAC Motor authorized shop for inspection.

5.2 Brake system

5.2.1 Service brake

Under certain driving and weather conditions, squeaks, screams, or other noises may be heard from brakes when the brake pedal is depressed for the first time or lightly stepped on, or braking noise accidentally heard during light or moderate braking, especially for new vehicles (as their brakes have not undergone running-in). This is normal and does not mean that the brake system is malfunctioning or the braking safety and performance is impacted.

CAUTION

- If there is metal friction rasp, the brake lining may be worn to the limit. Please go to the GAC Motor authorized shop for inspection as soon as possible.
- If the steering wheel vibrates or twitches continuously during braking, go to the GAC Motor authorized shop for inspection as soon as possible.

NOTE

- Do not rest your foot on the brake pedal during driving, otherwise the brakes will heat up to an abnormally high temperature, and the brake linings and brake pads will wear excessively, increasing the braking distance.
- When driving down a long slope or a steep slope, downshift to a low gear to avoid continuous applying the brakes. This can make full use of engine braking and reduce brake load.
- Continuous applying the brakes will cause brake overheat and result in a temporary reduction in braking performance.

5. Driving guide

NOTE

- Under normal driving conditions, the brakes will wear, and dust will accumulate on wheels. Wheel dust is inevitable, however, it will not affect the braking performance.
- If rust and corrosion exist because the brake linings and brake discs are not used or used rarely, noise may be heard from brakes for the first use. This is normal. It is recommended to choose a safe area and good road conditions and brake the vehicle several times to clean the brake linings and brake discs.

Brake booster

The brake booster is used to increase the pressure applied by the driver to the brake pedal, and it only works when the engine is running.

If the brake booster does not work properly due to a fault, or when the vehicle is towed, the force on the brake pedal must be increased to compensate for the brake booster.

WARNING

- **Never make the vehicle coast with the engine shut down. Otherwise, it is likely to cause an accident! Since the brake booster does not work at this time, the braking distance will be greatly increased.**
- **If the brake booster does not work (for example, when the vehicle is being towed), the brake pedal must be depressed with much greater force than normal for braking.**

Braking effect and braking distance

The braking effect and braking distance are mainly affected by the driving environment, road conditions and driving style.

With worn brake linings, the vehicle cannot be braked effectively. The wear rate of the brake lining mainly depends on the use conditions and driving style. If the vehicle is often used for urban driving, short-distance driving, or as a racing car, it is recommended to check the brake lining thickness more frequently than the maintenance cycle specified in the Warranty Manual.

After wading, heavy rain or vehicle washing, the brake lining may be wet or icy (in winter), resulting in a reduction in braking effect. In this case, the brake pedal must be lightly depressed to heat the brake by friction and evaporate the moisture to restore the braking effect.

WARNING

A new tire and brake lining having not undergone running-in do not have the best adhesion and friction characteristics.

- New tires do not yet have the best adhesion, so the vehicle must be driven carefully within the first 500km to avoid accidents!
- The new brake lining within the first 200km to 300km driving distance does not reach the best friction characteristics, and the braking effect is not as good as expected, so it must be subject to running-in. The braking effect can be compensated by increasing the force applied to the brake pedal. The new brake lining must also be subject to running-in.
- When driving, do not get too close to other vehicles or bring the vehicle to a situation where emergency braking is necessary. Take care especially when driving with a new tire and new brake lining having not undergone running-in, for fear of accidents!

WARNING

When the brake is wet or icy or when the vehicle is running on a salted road, the braking may lag, resulting in a longer braking distance. Therefore, be careful to prevent accidents.

- A longer braking distance or a fault in the brake system will increase the accident rate.
- Lightly depress the brake pedal to check the brake.
- Lightly depress the brake pedal to dry the brake or remove ice or anti-skid salt from the brake.

WARNING

Overheating brake will have reduced braking effect, increasing the braking distance!

- Take care to avoid overheating the brake.
- When driving downhill, the brake is likely to be overheated as the brake load increases.
- It is recommended to engage a low gear before driving down along a long steep slope to reduce the vehicle speed and make full use of the engine braking effect, so as to reduce the brake load.
- Do not keep depressing the brake pedal. Otherwise, the brake will overheat and the braking distance increases. Brake the vehicle intermittently according to road and traffic conditions.
- Do not shut down the engine and let the vehicle coast. Otherwise, the brake booster does not work and the braking distance greatly increases, which is likely to cause an accident.

5. Driving guide

WARNING

- The brake fluid must be changed every two years. If the brake fluid stays in the brake system for a long period, air resistance may occur in the pipeline during braking, reducing the braking effect significantly and impairing driving safety; it may even cause failure of the brake system, resulting in accidents!
- If a non-standard front spoiler is installed or the spoiler is damaged, it will block the cooling airflow to the brake, causing the brake to overheat and deteriorating the braking effect.

5.2.2 Electric park brake (EPB)*

The driver can apply or release EPB by operating the EPB button. On slopes, HSA can be used. If the accelerator pedal is depressed when the vehicle is parked, the EPB will be automatically released to provide driving assistance for the driver.

CAUTION

The EPB uses a fixed force to brake the vehicle according to the gradient.

- If the vehicle parked on a slope slides down, the EPB will automatically increase the braking force.
- If the vehicle continues to slide down after the braking force is automatically increased, please depress the brake pedal, drive the vehicle to a level road and stop it. Contact the GAC Motor authorized shop for inspection in time.

Apply the static park brake

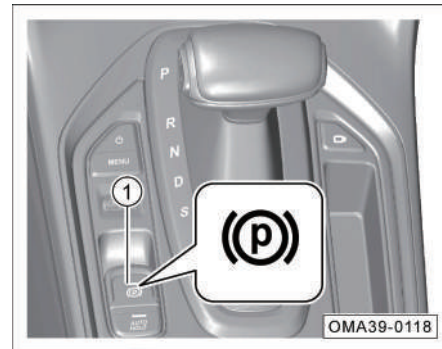

- When the vehicle is stationary, pull up the EPB button ① till the button indicator lamp and the indicator lamp (P) on the instrument cluster come on, indicating that the EPB has been applied to prevent slide.
- When the gearshift lever is switched to the “P” gear, the EPB will be applied automatically.

i NOTE

- The EPB can also be applied when the ignition switch is in the “OFF” position.
- After the vehicle is parked steadily, the EPB should be applied first.
- When the EPB is being applied, operation noise will occur, which is normal.
- If there is a trailer or the vehicle is parked on a steep slope, after the first application of EPB, the EPB button can be pulled up again to ensure the maximum braking force.
- On a 17%~30% slope, if the EPB is applied for the first time, after 5min, it will clamp again. Noise will occur at this time, which is normal.

⚠ WARNING

- The EPB must be applied during parking.
- When the vehicle is running, do not apply the EPB to reduce the vehicle speed unless necessary, as the EPB only applies braking force to rear wheels, which is likely to cause traffic accidents.

Release the static park brake

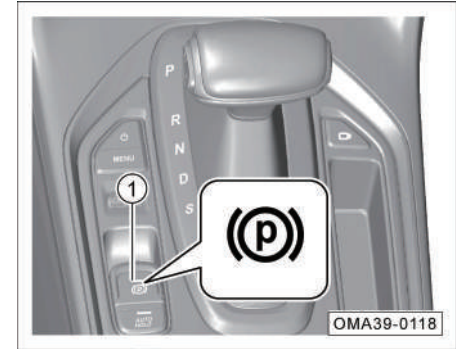

- When the ignition switch is in the “ON” position, depress the brake pedal.
- Press the EPB button ① till the button indicator lamp and the indicator lamp (P) in the instrument cluster go out, indicating that the EPB has been released.

5. Driving guide

i NOTE

- If the brake pedal is not depressed and the EPB button is pressed, the EPB will not be released, the buzzer will sound an alarm and the instrument cluster display will prompt “Please depress the brake pedal to release the EPB”.
- When the EPB is being released, operation noise will occur, which is normal.
- When the vehicle battery is low, the system cannot release the EPB. If possible, connect a jumper cable for emergency start => [See page 262](#) to release the EPB. In this case, contact the GAC Motor authorized shop for inspection.
- If the EPB has not been used for a long time, the system will automatically test it, and operation noise will occur.

Apply the dynamic emergency brake

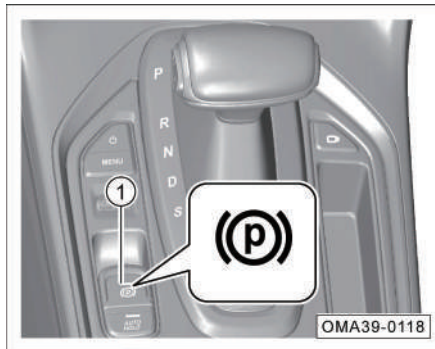

- If the service brake fails during driving, pull up the EPB button ① constantly to achieve emergency braking, and then release the EPB button or depress the accelerator pedal so the system exits emergency braking.

👁 CAUTION

In the following cases, operate the EPB again. If the fault is not eliminated, please contact the GAC Motor authorized shop for inspection.

- If the indicator lamp **(P)** flashes in red continuously, it indicates that the EPB is partially engaged/disengaged or the system is malfunctioning.
- If the indicator lamp **(P)** comes on in red when EPB is not applied, it indicates that the system is abnormal.
- If the indicator lamp **(P)** comes on in yellow, it indicates that a fault is detected in EPB and the EPB is degraded.

CAUTION

- Do not use dynamic emergency brake when it is not necessary. It is easy to cause traffic accidents, increases the braking distance in comparison to depressing the brake pedal to brake, and shorten the service life of the park brake system.
- If you pull up the EPB button when the vehicle is running, the instrument cluster will give an alarm message together with an audible beep alarm.
- If you release the EPB or depress the accelerator pedal during application of dynamic emergency brake, the EPB will be released. If the EPB button is pulled up until the vehicle stops, the EPB will remain engaged.

AUTO HOLD*

AUTO HOLD can keep the vehicle still automatically based on the driver's braking intention; when the system detects the driver's startup intention (for example, when the accelerator pedal is depressed), AUTO HOLD will automatically release the brake; AUTO HOLD can ensure the ease of startup when the brake is released automatically according to the slope information; AUTO HOLD can actively increase the pressure when the braking force is insufficient, so as to keep the vehicle still.

On and Off



- When the driver's door has been closed, the engine is started and the driver's seat belt is fastened, press the AUTO HOLD button ②. Then, the button indicator lamp comes on, and the AUTO HOLD is enabled. Press this button again. The button indicator lamp goes out, and the AUTO HOLD is disabled.

Activation

When this function is enabled, it supports automatic brake holding and releasing under stop & go conditions. When the driver brakes the vehicle, the vehicle will be automatically parked to avoid slide at startup.

Exit

Under the following conditions, AUTO HOLD will be disabled and the parking brake will not be locked:

1. The accelerator pedal is depressed at startup.
2. The engine stops while the vehicle is running.
3. The EPB is manually released.
4. When the brake pedal is depressed, the AUTO HOLD button is pressed.

5. Driving guide

To ensure safety, under the following conditions, the active AUTO HOLD function will be disabled and the parking brake will be locked:

1. The engine is shut down;
2. The driver's door is opened or the seat belt is unfastened when the vehicle is stopped.
3. The AUTO HOLD button is pressed to disable AUTO HOLD.

CAUTION

When driving into a mechanism such as a vehicle washing device that transports the vehicle through a conveyor belt, the AUTO HOLD function must be disabled, otherwise the vehicle cannot move or deviates from the path.

EPB self-learning

In some cases (for example, upon sudden battery failure or after long-term stop), the indicator lamp  will flash in red, and EPB will not work when the EPB button is pulled up manually. At this time, please depress the brake pedal, press and then pull up the EPB button, so that EPB button indicator lamp does not flash and EPB can complete self-learning to restore its normal operation.



5.3 Electronic service brake system

5.3.1 Electronic stability program (ESP)

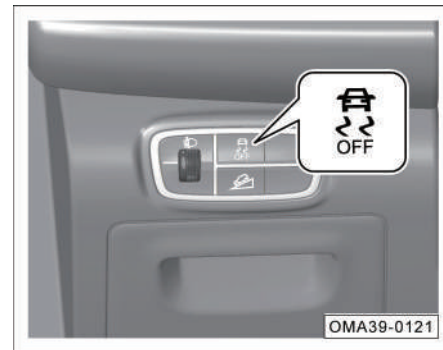

Electronic stability program (ESP) can effectively reduce the risk of sideslip.

On and Off









ESP is on by default when the vehicle is running. If the button  is pressed and held for a certain period of time (3-10s), the ESP will be deactivated, and the indicator lamp  on the instrument cluster will come on and an alarm message will be displayed.

NOTE

- When the vehicle speed is greater than 80 km/h, the ESP will be activated automatically.
- When the vehicle speed is less than 80km/h, the ESP, if inactive, can be activated by pressing the button .
- If the button  is pressed and held for more than 10 s, the system will identify it as a wrong operation, and the working state of the system will not be affected.

ESP indicator lamp

- After the ignition switch is switched to "ON" position, the indicator lamps  and  will be on for a few seconds and go out after the system completes self-test.
- If ESP works during driving, the indicator lamp  will flash.
- After ESP is deactivated, the indicator lamp  will light up.
- When ESP is faulty, the indicator lamp  will light up.

After the engine is started, if the indicator lamp  lights up, it indicates that ESP has been deactivated, and the instrument cluster display shows an alarm message. You can try to turn off and then on the ignition switch to activate the system again. When the indicator lamp  goes out, it indicates that the system has fully entered the working state.

If the battery connector is disconnected from and then connected to the cable, the indicator lamp  may come on when the ignition switch is turned on, and then goes out after a short driving distance.

For driving safety, it is recommended to enable ESP. The ESP can be disabled in the following special cases:

- when the vehicle travels with tire chains.
- when the vehicle travels on roads covered with deep snow or on soft grounds.
- when the vehicle is trapped on muddy roads, etc., and you need to move it back and forth.

Traction Control System (TCS)

TCS is a subsystem of ESP. As the subsystem of ESP, TCS determines if the driving wheel slips based on the speed of the driving wheel and the drive wheel, and if the speed of driving wheel is higher than that of drive wheel, it will limit the speed of the driving wheel to prevent vehicle slip.

When ESP is turned off or on, TCS will be turned off or on accordingly.

5. Driving guide

5.3.2 Anti-lock brake system (ABS)

Anti-lock brake system (ABS) is a subsystem of ESP. When the driver brakes, ABS automatically monitors the slip rate of the front and rear wheels, and when the wheels are to be locked, adjusts the wheel cylinder hydraulic pressure through pressure holding, depressurisation, and pressurisation to keep the wheel slip rate within the specified range, thereby preventing the wheels from being locked.







When the ABS starts working after the driver depresses the brake pedal in an emergency, the driver will feel the brake pedal shuddering, accompanied by the “click” sounds when the brake master cylinder is running. It is normal that shuddering is felt when the ABS works after the brake pedal is depressed in the following situations:

- During gear changes.
- During emergency braking.
- During sharp turns at high speed.
- When driving on slippery roads.
- When passing over bumps or ditches.
- When driving off immediately after starting.

Anti-lock braking system (ABS) indicator lamp

After the ignition switch is switched to “ON” position, the indicator lamp  on the instrument cluster will be on for a few seconds and go out after the system completes self-test.

If the following conditions occur, it indicates that the system is faulty:

- After the ignition switch is switched to “ON” position, the indicator lamp  on the instrument cluster does not come on.
- After the ignition switch is switched to “ON” position, the indicator lamp  on the instrument cluster does not go out after it is on for a few seconds.
- When the vehicle is running, the indicator lamp  on the instrument cluster lights up.
- When there is a fault in the ABS, the indicator lamps ,  and  on the instrument cluster will light up.

Electronic brake force distribution (EBD)

As a part of ABS, EBD balances the distribution of braking force on the front and rear wheels according to the vehicle load during normal braking.

Hydraulic brake assist (HBA)

Most drivers can brake in time in an emergency, but they cannot depress the brake pedal hard enough in a short time. Therefore, the brake system cannot generate the maximum braking force, resulting in an increase in braking distance as well as the risk of accidents.



WARNING

HBA can improve your driving safety, but it is impossible to exceed the laws of kinematics. Please adjust the driving speed according to the road conditions and traffic regulations.

5.3.3 Hill hold control (HHC)

HHC can prevent accidents resulted from sliding while driving off on a slope without application of the parking brake.

Activation conditions of HHC

- On a slope with a gradient greater than 4%, when “P” or “N” position is not engaged, the EPB is not applied, and the driver depresses the brake pedal to stop the vehicle and keep it still. If the driver releases the brake pedal in this case, HHC is activated to apply brake pressure to the vehicle and keep the pressure for 1 s.
- When the HHC function is working, if the engine torque exceeds the drag torque of the vehicle, the brake pressure will be released and you will pull away successfully.
- During driving downhill with “R” position engaged, the HHC function will also work.

i NOTE

- During driving off on a steep slope or driving downhill with “R” position engaged, HHC will automatically apply brake to prevent rolling down.
- HHC is integrated in the ESP system. If HHC fails, the ESP indicator lamp will come on, and an alarm message will be displayed on the instrument cluster display.

5.3.4 Hill Descent Control (HDC)

HDC is a subsystem of ESP. If the driver does not depress the brake pedal while going downhill, HDC will help the driver to decelerate via the ESP actively applying braking force.

On and Off

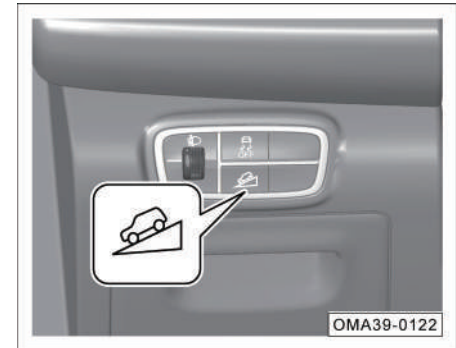

- When the vehicle speed is lower than 35 km/h, press the button to activate the HDC, and then the indicator lamp  comes on. The brake lamp comes on after the HDC is activated.

5. Driving guide

- Press the button again to deactivate the HDC, and then the indicator lamp  goes out.

After the HDC is activated, if the driver does not depress the brake pedal while going downhill, the vehicle keeps running at the speed of at least 8 km/h.

The driver can adjust the vehicle speed by depressing the accelerator pedal or the brake pedal:

- If the vehicle speed is 8~35 km/h when the pedal is released, HDC is activated again to keep the vehicle going downhill at the current speed.
- When the vehicle speed is higher than 60 km/h, HDC is automatically deactivated.
- When the HDC is active, ESP automatically intervenes in driving if the wheels slip excessively.

NOTE

- When the HDC has a fault, the function is deactivated and a graphic prompt message is displayed on the instrument cluster display with an audible alarm lasting for about 5 s. In this case, HDC cannot work properly, and the driver should depress the brake pedal to decelerate instead of trying to use the system to go down a steep slope. In addition, the driver should go to the GAC Motor authorized shop for inspection as soon as possible.
- In some special environments, the HDC enters the thermal protection mode due to too high braking temperature. For example, when the system operates at a high ambient temperature for a long time, the temperature of the brake system constantly increases due to friction. When the upper limit of temperature has been reached, the HDC enters the thermal protection mode (i.e., the HDC function is active but inoperative) and is temporarily deactivated, and the vehicle shows signs of acceleration. When the temperature of the brake system drops to the level where the brake system can work effectively, HDC resumes normal operation.

5.4 Driver assistance systems

5.4.1 Cruise control*

The cruise control allows the vehicle to run without depressing the accelerator pedal at the set and stored vehicle speed of 40~120 km/h.

WARNING

- **When driving on high-traffic roads, slopes, multi-curve roads or slippery roads, do not use the cruise control to avoid accidents.**
- **The cruise control shall be used with caution. After setting the vehicle speed, ensure that the vehicle can maintain a safe distance from the vehicle in front.**
- **The cruise control should be switched off in time after use.**
- **The cruise control is only used for assistant driving and cannot replace automatic driving, so the driver must be vigilant to drive and control the vehicle.**

Operational button

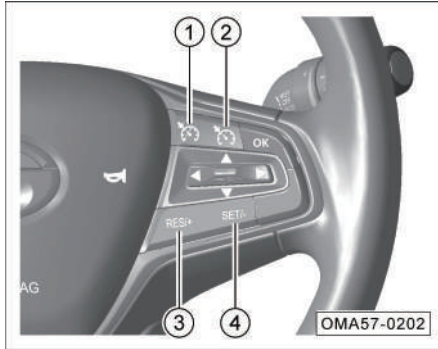

1. : exiting the cruise control.
2. : enabling/disabling the cruise control.
3. RES/+ : resetting the cruise control/acceleration.
4. SET/- : activating the cruise control/deceleration.

Enabling of cruise control

- If the button is pressed, the cruise control will be enabled, and the white indicator lamp in the instrument cluster will come on.
- Increase the vehicle speed above 40 km/h.
- If the SET/- button is pressed, the indicator lamp on the instrument cluster will turn green, and the vehicle will enter the cruise control status.

Exiting cruise control

The cruise control can be exited as follows:

- depressing the brake pedal.
- pressing the button (to exit the cruise control, but keep the set vehicle speed).
- pressing the button (to exit the cruise control and clear the set vehicle speed).
- pulling up the EPB button.
- starting the ESP system.
- set the gearshift lever to "N" position.

Resetting of cruise control

In case of the activated cruise control system, the indicator lamp on the instrument cluster will become white when the system is deactivated, and the cruise control can be reactivated by pressing the RES/+ button:

- When the vehicle speed is higher than 40 km/h, if the RES/+ button is pressed, the indicator lamp in the instrument cluster will turn green from white, and the vehicle speed will return to the value set during the last cruise control.

Increasing the cruising speed

- Press the RES/+ button; each time the button is pressed, the vehicle speed increases by 2 km/h.
- Press and hold the RES/+ button, after which the vehicle speed will continue increasing until the button is released.

NOTE

When the vehicle speed is lower than 40 km/h, it can no longer be adjusted by the SET/- button.

5. Driving guide

Reducing the cruising speed

- Press the SET/- button; each time the button is pressed, the vehicle speed reduces by 2 km/h.
- If the SET/- button is pressed and held, the vehicle speed will continue decreasing until the button is released.

i NOTE

- The maximum setable cruising speed is 120 km/h. When the vehicle speed is higher than 120 km/h, it cannot be adjusted by the RES/+ button.
- When the accelerator pedal is depressed for acceleration, the vehicle will temporarily deactivate the cruise control and run at the increased speed; after the accelerator pedal is released, the vehicle will resume the cruise control.

5.4.2 Adaptive cruise control (ACC)*

The adaptive cruise control, abbreviated to ACC, can automatically adjust the distance from the vehicle ahead in the cruise control mode, for which the applicable cruising speed is 0~120km/h.

ACC detects the relative distance and speed with the vehicle ahead on the same path according to the signals from the MMW radar installed on the front of the vehicle and the IFC installed on the windshield:

- If a vehicle in front is stopped, ACC controls your vehicle to follow the vehicle in front for automatic stop; if the vehicle in front is started, ACC controls your vehicle to start again under certain conditions. After stop for a specific time, your vehicle can be started by simply operating the RES/+ button or accelerator pedal as the vehicle in front is started.
- When the speed of vehicle in front is lower than the target speed set by the driver, ACC controls your vehicle to keep a safe distance from the vehicle in front.
- When no vehicle is in front, ACC controls your vehicle to travel at the target speed set by the driver.

i NOTE

Precautions for use of radars and cameras.=> [See page 185](#)

⚠ WARNING

- **ACC is not a safety system, obstacle detector, collision alarm or collision avoidance system, but a comfort system, so the driver must always keep control of the vehicle and take full responsibility for the vehicle.**
- **The ACC system must be used cautiously according to the visibility, weather conditions, road and traffic conditions at the time. The driver must always keep control of the vehicle and take full responsibility for the speed of the vehicle and the distance from other vehicles.**

Operational button

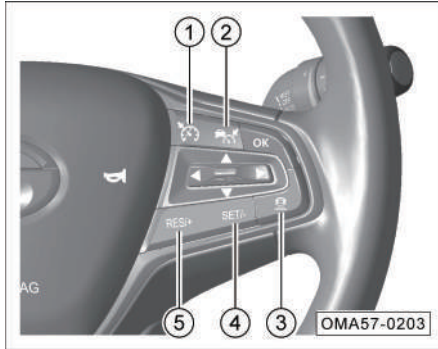

- ① : Canceling ACC
- ② : Activating/deactivating ACC
- ③ : ACC distance control
- ④ SET/-: Activating/setting ACC/deceleration
- ⑤ RES/+ : Resuming ACC/ acceleration

Interface description

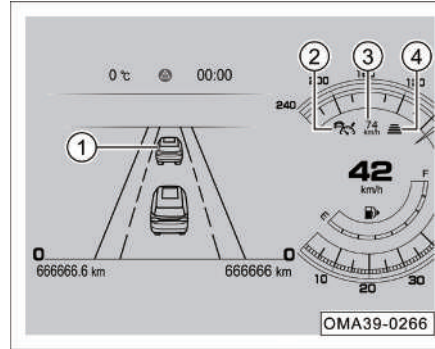

- ① indicates the detected vehicle in front.
- ② ACC indicator lamp:
 - If the white indicator lamp comes on, it indicates that ACC is in the ready state and a target vehicle is in front; if the green indicator lamp comes on, it indicates that ACC is working and a target vehicle is in front.
 - If the white indicator lamp comes on, it indicates that ACC is in the ready state and no target vehicle is in front; if the green indicator lamp comes on, it indicates that ACC is working and no target vehicle is in front.

- If the yellow indicator lamp comes on, it indicates that ACC is faulty. In that case, go to the GAC Motor authorized shop for inspection in time.
- ③ indicates the set cruising speed.
- ④ indicates the set cruising distance from the vehicle in front.



When the braking capacity of ACC is not enough to maintain a proper distance between your vehicle and the vehicle in front, ACC will send a “driver takeover request”, and the instrument cluster will display an alarm message and emit a sound simultaneously. In this case, the driver shall depress the brake pedal to reduce the vehicle speed according to the system requirements.

5. Driving guide

Activating ACC



- If the  button is pressed, the corresponding indicator lamp (white) in the instrument cluster will come on.
- If the SET/- button is pressed, the corresponding white indicator lamp in the instrument cluster will turn green.
- The vehicle enters the ACC control mode. Then, release the accelerator pedal.

NOTE

- The minimum cruising speed that can be set is 30 km/h.
- When the transmission gearshift lever is not in D position, ACC cannot be activated.
- When ACC is activated, the  indicator lamp in the instrument cluster comes on (when the  indicator lamp comes on, it indicates that a vehicle is in front), and meanwhile the instrument cluster shows the stored ACC speed and status.

Deactivating ACC

ACC can be deactivated by:

- opening the driver's door.
- unfastening the driver's seat belt.
- depressing the brake pedal.
- shifting the gear to "P", "N" or "R".
- pressing the  button (after that, the corresponding indicator lamp in the instrument cluster will turn white, and ACC will be deactivated temporarily, but the set speed will be kept).
- pressing the  button (after that, the corresponding indicator lamp in the instrument cluster will go out, ACC will be deactivated, and the set speed will be cleared).
- pulling up the EPB button.
- when the ESP system is turned off.
- when the HDC system is turned on.

If deactivated by the following ways, ACC may be resumed through the RES/+ button:

- depressing the brake pedal.
- pressing the  button.
- setting the gearshift lever to a forward gear.
- pulling up the EPB button. (The EPB should be released).
- when the ESP system is turned off (the ESP system should be turned on again).

Resuming ACC

When the corresponding white indicator lamp in the instrument cluster comes on, ACC can be reset by the following ways:

- pressing the RES/+ button, after which the corresponding green indicator lamp in the instrument cluster will come on, the vehicle speed will return to the value set during the last cruising, and the cruise control mode will be entered. If the cruising speed has not been stored and the SET/- button is pressed, ACC will set the current vehicle speed as the cruising speed (if the current vehicle speed is less than 30 km/h, the cruising speed will be set at 30 km/h).

If deactivated by the following ways, ACC cannot be resumed through the RES/+ button:

- pressing the  button.
- setting the gearshift lever to a non-forward gear.

Increasing the cruising speed

To increase the vehicle speed, please perform the following operations:

- depress the accelerator pedal to increase the vehicle speed as desired and press the SET/- button for cruising at the increased speed.
- Press the RES/+ button; each time the button is pressed, the vehicle speed increases by 1 km/h.
- press and hold the RES/+ button to increase the vehicle speed at an increment of 5 km/h.

NOTE

- The maximum cruising speed that can be set is 120 km/h.
- When the accelerator pedal is depressed for acceleration, the vehicle will temporarily deactivate the cruise control and run at the increased speed; after the accelerator pedal is released, the vehicle will resume the cruise control.

Reducing the cruising speed



To reduce the vehicle speed, please perform the following operations:

- Press the SET/- button; each time the button is pressed, the vehicle speed reduces by 1 km/h.
- press and hold the SET/- button to reduce the cruising speed at a decrement of 5 km/h until the button is released or the cruising speed is 30 km/h.
- during the cruising process, slightly depress the brake pedal (with ACC deactivated), keep braking until the target speed is reached, release the brake pedal, and press the SET/- button to cruise at the target speed.

5. Driving guide



ACC distance control

After the ignition switch is set to "ON" position, when ACC is activated, the default distance from the vehicle in front is in the fourth range (the following distance in the fourth range is the farthest).

By pressing the  button, the distance from the vehicle in front can be changed recurrently in four ranges in the order of "fourth range → third range → second range → first range → fourth range...". At the same time, the cruising distance indicator lamp  in the instrument cluster will display the same number of cross bars as the ordinal number of the gear.

Activating ACC after following stop

In the process of following a vehicle in front, your vehicle will also be stopped if the vehicle in front is stopped. During a period of following stop, ACC will keep your vehicle stationary by active pressurization of ESP; after a period of time, ACC will keep your vehicle stationary by activating EPB. When the vehicle in front leaves, ACC of your vehicle may be activated as follows:

1. If the indicator lamp  is green, after the vehicle in front leaves, ACC can be reset actively and re-drive your vehicle;
2. If the indicator lamp  turns white and EPB is not activated, ACC can be reset actively and re-drive your vehicle by pressing the RES/+ button or depressing the accelerator pedal;
3. If the indicator lamp  turns white and EPB is activated, ACC can be reset and re-drive your vehicle by depressing the accelerator pedal first, waiting for EPB to be automatically released, and then pressing the RES/+ button.

Special driving environment

As limited by physical laws, ACC has a certain system limitation. In some driving environments, the driver may feel a response lag of ACC or may fail to control the vehicle as expected, so he or she must always be ready to control the vehicle.

The following conditions affect functions of the radar system sensor and camera sensor, so the driver must be particularly alert under these conditions:

1. Decelerating to stop. If the vehicle in front is stopped after braking, ACC will also decelerate your vehicle until the alarm is deactivated. In that case, the driver may actively intervene in the brake as needed to stop your vehicle completely.

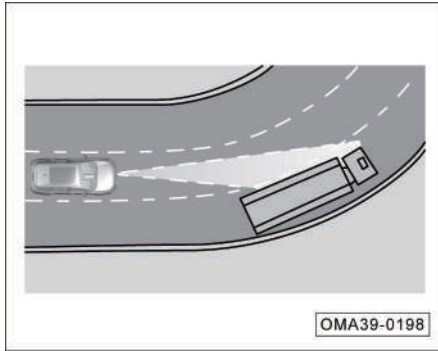

2. Driving through a curve. During driving through a curve, the radar sensor or camera sensor may fail to capture the vehicle in front in this lane, or may react to vehicles in adjacent lanes. In this case, ACC may not respond to the vehicle in front, or may brake your vehicle to reduce the vehicle speed. ACC can be deactivated by depressing the brake pedal or pressing the “Canceling ACC” button.

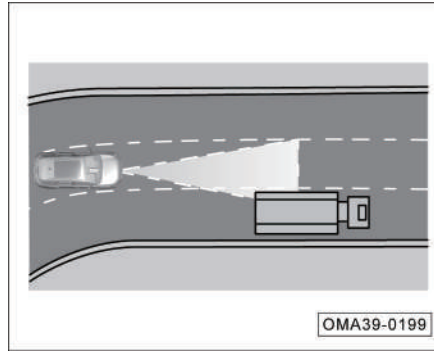

3. Driving out of a curve. During driving out of a long curve, because ACC will calculate the lane in advance, the radar sensor may respond to the vehicles in adjacent lanes and apply the brake of your vehicle. This braking process may be interrupted by depressing the accelerator pedal.

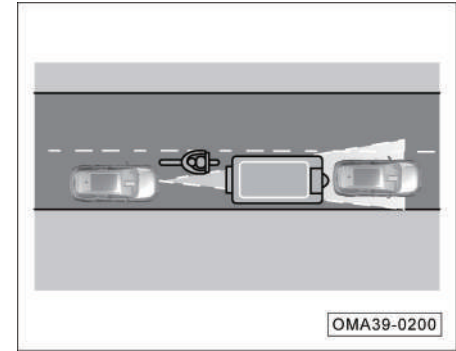

4. Narrow vehicles and Z-shaped traffic in front. When narrow vehicles and Z-shaped traffic in front enter the detection range of the radar sensor and the forward camera sensor, the sensors can be identified, but ACC cannot identify vehicles out of the detection range of the sensors. ACC may be unable to identify narrow vehicles such as motorcycles and electric bicycles, and has a risk of failing to accurately identify the distance from modified vehicles and vehicles involving non-standard transportation in front, so the driver should be particularly alert and always be ready to take over the vehicle.

5. Driving guide

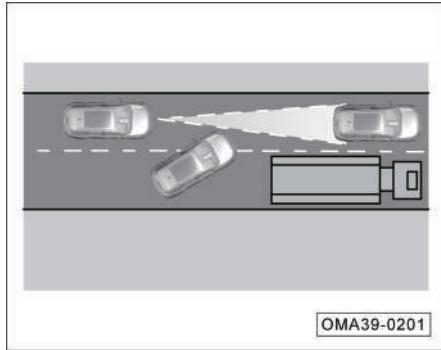

5. When another vehicle changes the lane. When a vehicle in the adjacent lane moves into the lane in which your vehicle travels, the front radar may fail to detect it if it is not in its detection range, thus resulting in a response lag of ACC.

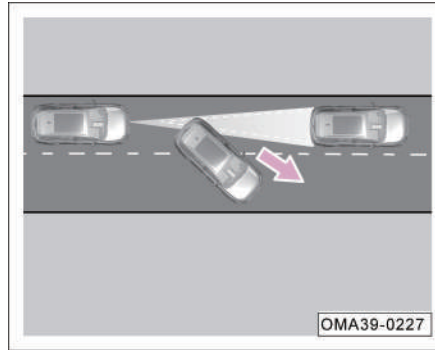

6. If the target vehicle in front is driven out suddenly and a stationary vehicle appears at close range, the radar sensor and brake actuator will incur a response lag, causing delayed braking response.

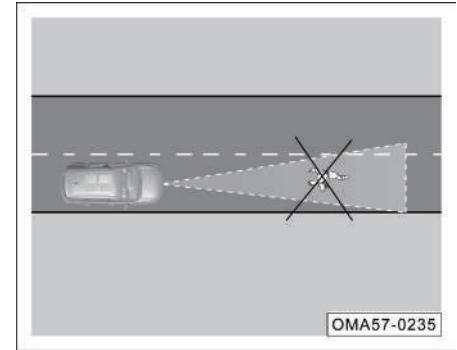

7. ACC should not be used in cities with traffic jams and poor visibility (night/backlighting/rain/snow/dense fog, etc.). ACC does not take braking measures in face of people, animals or special purpose vehicles such as tanker trucks, dump trucks and dolly carts. When this vehicle travels at a speed higher than a certain level, the probability of ACC recognizing stationary vehicles is inversely related to the speed; if the speed is higher than 60km/h, ACC does not take braking measures, so the driver should be particularly alert and always be ready to take over the vehicle.

8. Influencing factors that may deteriorate the sensor function:
 - a. Heavy rain, water mist, ice, snow or sludge may deteriorate the function of the radar sensor. As a result, ACC is deactivated temporarily. And meanwhile the instrument cluster displays the following text messages: "ACC is currently out of service", "Please check the forward collision warning system" or "Please check the autonomous emergency braking (AEB)". At this time, a malfunction occurs to the forward collision warning system, ACC and autonomous emergency braking (AEB).
 - b. Due to temperature difference or frost in low-temperature and alpine areas, the front windshield is frosted and fogged. As a result, the camera sensor is obstructed, and the instrument cluster displays the following text messages: "ACC is currently out of service", "Please check the forward collision warning system" or "Please check the autonomous emergency braking (AEB)". At this time, a malfunction occurs to the forward collision warning system, ACC and autonomous emergency braking (AEB).
9. Brake overheating. If the brake is overheated due to emergency braking or during traveling down a steep slope, ACC will be deactivated automatically and temporarily, and meanwhile the instrument cluster will display the following text message: "ACC is currently out of service". After that, ACC can no longer be activated. ACC can only be reactivated when the brake temperature drops to a reasonable degree.

WARNING

- **The driver must always be ready to control the vehicle by himself or herself.**
- **The adaptive cruise control (ACC) function cannot cover all driving scenarios and traffic, weather and road conditions.**
- **The function of ACC is only to supplement the driving assistance function. Even when used, the function cannot replace your attention and judgment. It is your responsibility to maintain a safe distance and speed, and you must intervene if the adaptive cruise control (ACC) fails to maintain a proper speed or distance from the vehicle ahead.**
- **For the sake of safety, do not use ACC under conditions such as urban driving, traffic jams, multi-curve roads and poor road conditions (e.g. icing, fog, gravel, heavy rain, and phenomena prone to water skiing).**

WARNING

- **Do not activate ACC during driving in roadless areas or on earth roads. ACC can only be activated on hard roads.**
- **The hands-on reminder alarm of ACC only warns the driver of vehicles detected by its radar and camera sensors, so ACC may not send an alarm, or may send an alarm with a certain delay. Never wait for an alarm, but apply the brake as needed.**
- **The adaptive cruise control (ACC) is not a collision avoidance system. If your vehicle is getting closer and closer to the vehicle in front and your vehicle speed is higher than that of the vehicle in front, the braking effect of ACC cannot ensure safety, so the driver must depress the brake pedal to reduce the vehicle speed when your vehicle is possible to collide with the vehicle in front.**

5. Driving guide



WARNING

ACC does not respond to or only makes a limited response to the followings:

- **large speed difference between your vehicle and the vehicle in front.**
- **driving in different lanes, lane changes or driving on curves with small radius.**
- **pedestrians, animals, bicycles, stationary vehicles or unexpected obstacles.**
- **complex traffic conditions.**
- **oncoming traffic or cross traffic.**
- **low trailers or trucks, high frame/high body trucks, and vehicles with irregular/non-standard towing or characteristics.**

Therefore, be sure to notice traffic conditions and respond accordingly. Do not wait for the system to identify the target or apply the brake, but apply the brake as needed.



CAUTION

- ACC could not respond under certain circumstances. For example, when your vehicle approaches a stationary obstacle such as a broken-down vehicle or a vehicle stuck in traffic jams, or when a vehicle traveling in the same lane approaches your vehicle, ACC may not respond.
- ACC does not respond to people, animals and vehicles crossing or approaching your vehicle in the same lane.
- During driving through crossroads, speed bumps, steep roads and zebra crossings, or at changing lanes, highway access, ramps or construction sections, it is required to deactivate ACC and adopt fully manual driving, lest the vehicle should be automatically accelerated to the set speed, causing traffic accidents.



CAUTION

- ACC can automatically drive the vehicle out after a brief stop or confirmation from the driver (control of buttons or accelerator pedal). During this period, the driver must ensure that there are no obstacles or other traffic participants (such as, pedestrians/bicycles/motorcycles /tricycles) directly in front of the vehicle.
- Do not bump the radar sensor. If the sensor is misaligned due to bumps, even after correction, it will still deteriorate the system performance and even cause the system shutdown.
- If the surface of the radar or camera sensor is dirty or covered by heavy rain, ice, snow, sludge, etc., ACC may not function, and the instrument cluster will display the message "Please check ACC". After dirt is cleaned off the sensor surface, the function will be reset and return to normal.

CAUTION

- Do not spray the front bumper with vehicle paint without permission, otherwise the performance of the frontal radar may be degraded.
- Do not spray or decorate the vehicle logo without permission, otherwise, the performance of the forward radar may be degraded.

NOTE

- ACC can only achieve limited braking force, not emergency braking.
- Please be careful not to unintentionally put your foot on the accelerator pedal; otherwise, ACC will no longer apply the brake of the vehicle. This is because if the driver depresses the accelerator pedal, the vehicle speed and distance may be controlled excessively.
- If ACC fails to function as described in this chapter, do not continue using it. In that case, go to the GAC Motor authorized shop for inspection in time.
- When your vehicle is traveling in heavy rain or snow, and ACC is difficult or unable to identify the vehicle in front, ACC shall be deactivated.
- If your vehicle is getting closer and closer to the vehicle in front and your vehicle speed is higher than that of the vehicle in front, the braking effect of ACC cannot ensure safety, so the driver must depress the brake pedal to reduce the vehicle speed.

NOTE

- When ACC is activated, its status displayed on the instrument cluster display may be overwritten by other functions (for example, during a telephone call).
- When ACC brakes the vehicle automatically after activation, there will be a sound different from manual braking sounds or the brake pedal will be depressed automatically, which is normal. This sound and pedal action are caused by the operation of the brake system, so there is no need to worry.
- For the sake of safety, the stored cruising speed will be deleted after the ignition switch is turned off.

i NOTE

- The accelerator pedal can be depressed at any time to increase the vehicle speed. After the accelerator pedal is released, ACC will readjust the vehicle speed to the previously stored value.
- If the vehicle enters a tunnel, the radar may enter the blind mode, and ACC may be deactivated temporarily.

5.4.3 Traffic Jam Assist (TJA)/ Integrated cruise assist (ICA)*

The TJA/ICA system detects the relative distance and speed between the vehicle ahead in the same path and this vehicle through the MMW radar installed on the front of the vehicle, and detects the lane marking on roads through the IFC installed on the front windshield. At the same time of vehicle following and cruise, the system controls the vehicle to stay in the middle of the lane and assists the driver in lateral and longitudinal intelligent handling.

During cruise, the system can automatically adjust the distance from the vehicle ahead and keep the vehicle traveling in the middle of the lane.

Precisely, the system is called Traffic Jam Assist (TJA) in the speed range of 0-60km/h, and Integrated Cruise Assist (ICA) in the speed range of 60-120km/h.

Operation instruction

The driver can select "TJA/ICA" in "Vehicle Settings → Driving Assistance → Cruise Mode" in the AV system.

After being selected, TJA/ICA can be turned on or activated according to the operation mode of ACC. Operation mode of ACC => [See page 155](#).

The cruise mode can be switched when ACC is deactivated, turned on or activated.



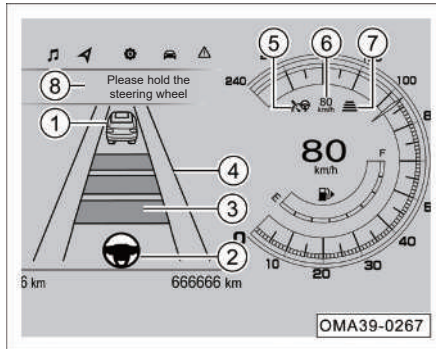

TJA/ICA has a cruise mode memory function that keeps the cruise mode the same as that before last engine shutdown when the engine starts.

When TJA/ICA has a specific fault not affecting ACC, the cruise mode will automatically jump back to ACC mode. At this time, the driver cannot choose to enter the TJA/ICA mode, but ACC can still be used normally.

Interface description



- ① indicates the detected vehicle in front.
- ② indicates the lateral control status:

- If the gray indicator lamp  comes on, it indicates that TJA/ICA is not performing lateral control currently.
- If the green indicator lamp  comes on, it indicates that TJA/ICA is performing lateral control currently.
- ③ indicates longitudinally controlling the target distance from the vehicle in front, totaling four gears.
- ④ indicates whether a valid lane marking is detected currently. The green highlight indicates that a valid lane marking is detected. Otherwise, no valid lane marking is detected.
- ①, ②, ③ and ④ are displayed for a long time only when the function of TJA/ICA is activated. They are not displayed when the function is enabled but not activated.
- ⑤ TJA/ICA indicator lamp:
 - If the white indicator lamp  comes on, it indicates that the TJA/ICA is in the ready state and does not control the longitudinal and lateral directions of the vehicle.
 - If the green indicator lamp  comes on, it indicates that the TJA/ICA is activated and may control the longitudinal and lateral directions of the vehicle simultaneously, or the horizontal control may be suppressed currently (judged according to the steering wheel color of ②).

- ⑥ indicates the currently stored cruising speed.
- ⑦ indicates the set cruising distance from the vehicle in front.
- ⑤, ⑥ and ⑦ are displayed for a long time when the function is enabled.
- ⑧ When the driver has taken hands off the steering wheel, the text "Please hold the steering wheel" will be displayed. After the driver continues to take hands off the steering wheel for a period of time, the text will flash at a frequency of 1Hz, accompanied by a beep.

Lateral control

When "TJA/ICA" is selected in cruise mode, if the ACC button on the steering wheel is pressed, TJA/ICA lateral control will be activated automatically upon detection of valid lane markings on both sides and the system will control the vehicle to stay in the middle of the lane.

The lateral control will be automatically exited under the following conditions, to which the driver shall pay close attention:

- The curvature of lane marking is too high (curve <250 m).
- The lane markings on one or two sides are missing.

5. Driving guide

- Intense driving conditions lead to excessive body yaw, ESP activation or ABS activation.
- Turn signal lamp is turned on.
- The hazard warning lamp is turned on.
- The driver still does not hold the steering wheel after the system issues a hands-on reminder when both hands are taken off the steering wheel for a long time.
- The lane is too wide (>5.5 m).
- The lane is too narrow (<2.5 m).
- The vehicle changes the lane.
- The driver holds the steering wheel with excessive force.
- The driver applies the brake.
- The EPS is faulty.
- The ACC is deactivated. Deactivating condition of ACC => [See page 156](#).

TJA/ICA can only use the limited capability of steering system, so it cannot cover all driving conditions. The driver must keep his hands on the steering wheel at all times and drive carefully.

When TJA/ICA intervenes in the steering wheel for lateral assist control, the driver can still turn the steering wheel to control the vehicle. When feeling that the torque applied by the system is improper, the driver can control the vehicle to travel according to his intention at any time.

Hands-on reminder

TJA/ICA is a secondary system, which cannot replace the driver's steering operation. When the system detects that the driver has taken hands off the wheel, the text "Please hold the steering wheel" will first pop up in the upper center of the instrument panel (always-on display). After the driver continues to take hands off the steering wheel for a period of time, the text will flash at a frequency of 1Hz, accompanied by a beep. In that case, if the driver still does not hold the steering wheel, the beep will become sharp and an alarm image of immediate hands-on will pop up.

The driver shall immediately hold the steering wheel when any of the above hands-on reminders has been received. Don't panic or turn the steering wheel fiercely.

After TJA/ICA recognizes that the driver is holding the steering wheel by detecting the torque manually applied to the steering wheel, the hands-on reminder will disappear automatically, and TJA/ICA will reactivate the lateral assist function automatically.

CAUTION

After a steering wheel hands-on reminder is issued, the lateral assist function of TJA/ICA will be deactivated.

When the driver's hands are lightly holding on the steering wheel, the system may misinterpret it as the steering wheel out-of-hand. In this case, when the system issues a steering wheel hands-on reminder, the driver only needs to hold the steering wheel tightly or shake the steering wheel slightly, so that the system can detect the torque applied to the steering wheel. Afterwards the hands-on reminder will disappear.

TJA/ICA can only use the limited braking capacity of the service brake system. When TJA/ICA requires the driver to intervene in braking, the instrument cluster will display a message "Please depress the brake pedal" with the buzzer sounding.

When receiving the hands-on reminder, the driver shall immediately depress the brake pedal for proper braking.

After the brake pedal is depressed, TJA/ICA will be deactivated. If TJA/ICA reactivation is required after an emergency is eliminated, press the resetting or setting button of ACC.

Functional limitation

Because TJA/ICA can only use the limited capacity of the steering system and brake system, TJA/ICA cannot maintain an appropriate headway or keep the vehicle in the lane under all road conditions.

TJA/ICA may incorrectly detect lane markings or fail to detect lane markings, and may incorrectly detect target vehicles or fail to detect target vehicles in front.

TJA/ICA may incorrectly detect lane markings or fail to detect lane markings, and may incorrectly detect target vehicles or fail to detect target vehicles in front.

When TJA/ICA is degraded to ACC, the small icon of steering wheel in the middle display area of instrument cluster turns gray and the lane markings turn gray.

At the moment of TJA/ICA degradation caused by missing lane markings, high curvature of lane markings, too wide lanes, too narrow lanes, running across the lane marking, hazard warning lamp turned on, excessive body yaw, etc., TJA/ICA will give a “clatter” sound, and the text “The lateral assist function of TJA/ICA is deactivated” will pop up on the instrument cluster.

Even if the function is enabled and activated, TJA/ICA may be affected, malfunction or not function under the following conditions:

- Isolation strips or other objects casting shadows on lane markings.
- Short-term change of marking, such as ramp or highway exit.
- Driving on steep slopes or curved roads.
- Close distance from the vehicle in front or lane markings blocked by the vehicle in front.
- Severe shaking of the vehicle.
- Sudden changes in outdoor brightness, such as entering/exiting tunnels.
- Headlamp not turned on at night or when the light is low in tunnels.
- No lane marking, or difficulty in distinguishing the lane marking color from the road surface color.
- Possibility of deflecting the vehicle to the lower side because the system cannot identify horizontally sloping roads.
- Unobvious, too thin, worn, blurred or dirt/snow-covered lane markings.
- Too wide or narrow lanes.
- Increase or decrease of lanes, or complicated routing of lane markings.
- More than two lane markings on the left and right sides of the vehicle.
- Marks or objects similar to lane markings on roads.
- Fences on lane markings.
- Possibility of mistaking flower beds, curbs, and iron sheet for road maintenance as lane markings.
- Fishbone-shaped (FS) markings with speed reduction sign.
- Red lane marking is on road due to road maintenance.
- Poor line of sight caused by, e.g., snow, rain, fog or water spots.
- Dirty or foggy windshield, or obstruction in front of the windshield camera.
- Overtemperature around the camera due to direct sunlight.

5. Driving guide

Longitudinal control of TJA/ICA is based on ACC. For more limitation conditions, please refer to the relevant chapters of ACC => [See page 158](#).

The lateral assist control performance of TJA/ICA may be affected under the following conditions:

- Vehicle overload.
- Lateral centering performance greatly affected by insufficient, high or low tire pressure. Be sure to maintain the standard tire pressure recommended by GAC Motor, and check the tire pressure at least once a quarter.
- Uneven road.
- Strong crosswinds.
- Modification of vehicle control-related parts by the driver.
- Replacement of vehicle control-related parts with non-genuine parts.
- improper assembly of vehicle control-related parts.

WARNING

- **TJA/ICA is only an assist system and cannot cope with all road, traffic and weather conditions. It is the responsibility of the driver to always pay attention to road conditions and actively control the vehicle.**
- **TJA/ICA is only an assist system, which cannot replace the driver's operation. Therefore, the driver should supervise braking and steering at all times, and not take hands off the steering wheel. The driver must keep control of the vehicle in real time, and actively intervene in braking as necessary. The driver should always assume the ultimate responsibility for the vehicle safety and comply with laws and road traffic rules.**
- **Before using TJA/ICA, the driver must read through all chapters about this function in the user manual to understand the system limitations of this function. Before using this function, the driver shall be aware of these limitations.**

WARNING

- **TJA/ICA is not a collision avoidance system. When TJA/ICA does not take proper control, the driver must intervene.**
- **TJA/ICA shall be used in scenarios with less traffic on a highway. Under conditions such as urban traffic, crossroads, water-logged or snowy roads, adverse weather, mountain roads, ordinary country roads, rough roads and highway access, do not use TJA/ICA. Do not use TJA/ICA when the vehicle is connected to a trailer.**
- **TJA/ICA can only use the limited capability of steering system, so it cannot cover all driving conditions. The driver must keep his hands on the steering wheel at all times and drive carefully. The driver must hold the steering wheel or reduce the vehicle speed appropriately on high-speed curves.**

WARNING

- TJA/ICA does not always identify lane markings correctly. Lane markings may be omitted by TJA/ICA due to adverse weather, poor night lighting, water and snow on road surfaces, damage and blurs of lane markings, etc. Specific objects and structure may be mistaken for lane markings due to road surface damage, water and snow on curb, other road structure and road surfaces, shadows cast on road surfaces, etc. Therefore, TJA/ICA may not generate lateral assist torque when needed, or may generate unnecessary lateral assist torque by mistake. It is the responsibility of the driver to always pay attention to road conditions and actively control the vehicle.

WARNING

- TJA/ICA cannot detect objects or accessories on a target vehicle that protrude from the body side, rear end or roof. If a vehicle in front is equipped with the aforementioned special objects or special equipment, please be sure to deactivate TJA/ICA when overtaking such vehicle. In this case, the driver should actively apply steering and braking according to the practical conditions.
- TJA/ICA cannot perform braking for pedestrians, animals, foreign objects, lowbed trailers or oncoming traffic.
- If a vehicle in front is driven in or out when TJA/ICA is activated, you need to be on high alert and ready to take over the vehicle at any time.

WARNING

- Improper use of TJA/ICA or negligence may lead to accidents. The driver always bears the ultimate responsibility for controlling the vehicle and maintaining an appropriate speed and headway to keep the vehicle traveling correctly in the lane, even if using TJA/ICA.
- TJA/ICA does not work for all traffic conditions. Because the lateral assist may be suddenly exited under conditions such as high curvature of lane marking before a sharp curve (with the radius less than 250 m), and roads without lane markings, the driver must always hold the steering wheel to actively control the vehicle. It is the responsibility of the driver to always pay attention to road conditions and actively control the vehicle.

5. Driving guide

5.4.4 Forward collision warning system *

The FCW system assesses the danger level of pre-collision by detecting the relative distance and speed between the vehicle ahead in the same path and this vehicle through the MMW radar installed on the front of the vehicle and the IFC and synthesizing driver's other operations (such as depressing the brake pedal or accelerator pedal), warns the driver as necessary, and timely reminds the driver to take measures to avoid or mitigate the collision in case of a collision risk.

i NOTE

Precautions for use of radar and camera sensor. => [See page 185](#)

On and Off

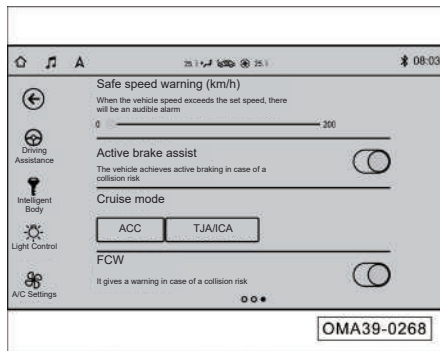

When the FCW switch is set to “ON” position and the vehicle speed is greater than 30 km/h, the FCW system will be activated automatically. The function of FCW can be deactivated manually, and activated manually if needed.

It can be activated/deactivated manually as follows:

- enter “Vehicle Settings → Driving Assistance → FCW” in the AV system and select activation/deactivation to set the FCW system.

i NOTE

After being turned off, the forward collision warning system will no longer warn of vehicle and pedestrian targets.

Warning alert

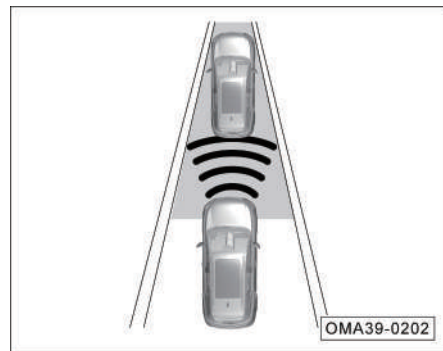

When the forward collision warning system gives a warning, there are three types of prompts:

1. Distance warning.

The distance warning will be triggered in case of too short distance between your vehicle and the traffic and a general risk of collision. At that time, an icon will flash on the instrument panel.

2. Proximity warning.

When the warning of forward collision warning system is triggered, an icon will flash on the instrument cluster and an audible alarm will be given at the same time.

3. Brake jerk warning.

Brake jerk warning will be triggered in case of a high risk of collision. At that time, a brake jerk will be applied to better remind the driver to apply the brake.

NOTE

- “Far, medium and near” can be set through the “Vehicle Settings → Driving Assistance → Forward Collision Warning Distance” in the AV system. There is a memory function for the forward collision warning distance to remember the last set warning distance.
- Depressing the accelerator pedal or turning the steering wheel will terminate the warning given by the forward collision warning system.
- The applicable speed of distance warning is greater than 60 km/h, to avoid distracting the driver’s attention by frequently triggering the warning at low speeds.
- The applicable speed of proximity warning is greater than 30 km/h.

WARNING

It is impossible for the forward collision warning system to violate the laws of physics. Never use the convenient functions provided by the forward collision warning system to make risky travel.

- **The forward collision warning system is unlikely to remind the driver to avoid a collision under any circumstances.**
- **In a complex driving environment (e.g., during traveling on a circuitous road), the forward collision warning system may give an unnecessary warning.**
- **If the forward collision warning system gives a warning, the driver must apply the brake to reduce the vehicle speed or avoid obstacles according to traffic conditions.**
- **The forward collision warning system is only a warning system to remind the driver to avoid collisions. Since the system does not replace the driver in providing the corresponding active brake assistance when the warning is triggered, the driver must always keep control of the vehicle and take full responsibility for the speed of the vehicle and the distance from other vehicles.**

5. Driving guide

5.4.5 Autonomous emergency braking (AEB)*

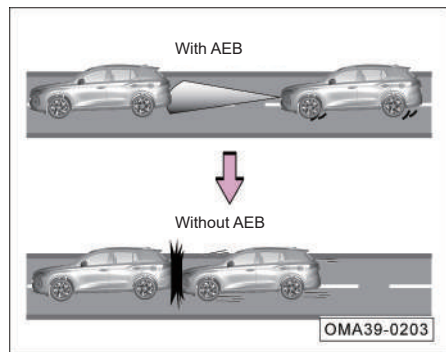

The Autonomous Emergency Braking (AEB) assesses the danger level of collision by detecting the relative distance and speed between the vehicle ahead in the same path and this vehicle through the MMW radar installed on the front of the vehicle and the IFC and synthesizing driver's other operations (such as depressing the brake pedal or accelerator pedal), and intervenes in braking if necessary. When a prospective collision is detected, AEB will automatically brake the vehicle. When the driver is braking while the braking force is insufficient to avoid a collision, the system will automatically increase the braking force to avoid or alleviate the collision.

i NOTE

Precautions for use of radar and camera sensor. => [See page 185](#)

On and Off

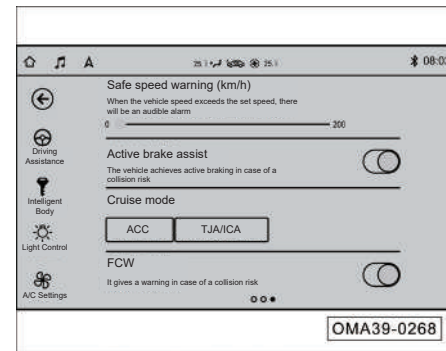

When the AEB switch is set to "ON" position and the vehicle speed is greater than 8 km/h, the function of AEB will be activated automatically. The function of AEB can be deactivated manually, and activated manually if needed.

It can be activated/deactivated manually as follows:

- Enter "Vehicle Settings → Driving Assistance → AEB" in the AV system and select activation/deactivation to set the AEB.

i NOTE

When active brake assist is deactivated, the system stops taking braking measures to vehicles and pedestrians.

AEB braking level

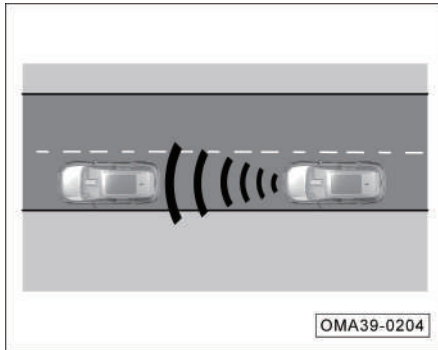

- First-level braking: Brake jerk is performed while this vehicle is approaching a vehicle ahead.

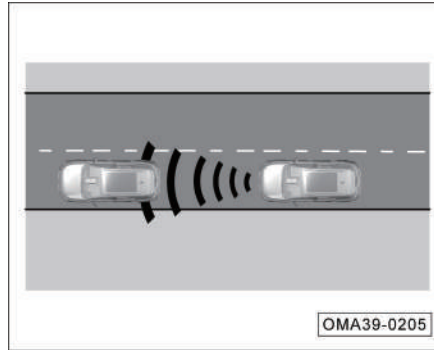

- Second-level braking: Slight automatic emergency braking is performed while this vehicle continues to approach a vehicle ahead.

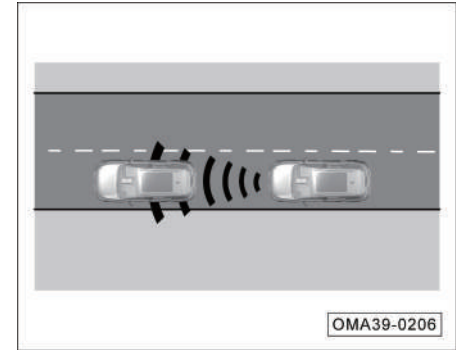

- Third-level braking: Fully automatic brake is performed because a rear-end collision is inevitable.

The AEB system must be deactivated under the following conditions:

- The vehicle is towed.
- The vehicle is on a chassis dynamometer.
- A radar sensor or camera sensor has a fault.
- An external force (such as a rear-end collision) acts on the radar sensor.

5. Driving guide

The AEB system may be inoperative under the following conditions:

- The vehicle passes an extremely tight turn.
- The accelerator pedal is depressed to the floor.
- The accelerator pedal is depressed quickly.
- The forward gear is not engaged.
- The ESP system is manually deactivated.
- The driver's seat belt has not been fastened.
- A radar sensor or camera sensor is dirty or covered.
- The vehicle runs in a snowy or heavily rainy day.
- A narrow vehicle (such as a motorcycle) is driving ahead.
- The vehicle meets a crossing approaching vehicle.
- In case of a stationary obstacle (such as a vehicle with unplanned stop).
- There is an oncoming vehicle.
- In case of an animal, an oncoming vehicle or a road-crossing vehicle.
- When AEB is negatively affected by the environment (for example, electromagnetic interference or the target itself), the detection function will be interfered and the AEB performance will be degraded.

NOTE

- Depressing the accelerator pedal or turning the steering wheel terminates AEB system's intervention in braking.
- When the AEB system is triggered, braking force will be applied to the vehicle and the foot may feel vibration from the brake pedal, which is normal.
- In case of a complex driving condition (such as roundabout driving), the AEB system may need to intervene in braking.
- When AEB is negatively affected by the environmental factors (for example, electromagnetic interference or the target itself), the detection function will be interfered and the AEB performance will be degraded.

WARNING

The AEB system can improve the driving safety, but it is impossible to go beyond the laws of kinematics. Thus never drive riskily with the convenience provided by the system. The driver must always be ready to apply the brake, in order to reduce the vehicle speed or avoid obstacles.

The AEB system can only apply limited braking to reduce injuries due to collision. It is impossible for the AEB to autonomously prevent vehicle accidents or personal injuries. Therefore, when the AEB system is working, it is necessary to apply the brake as the circumstances may require.

When the AEB system is activated, the driver shall keep controlling the vehicle during driving and shall take full responsibility for the vehicle speed and the distance to other vehicles.

WARNING

The AEB system only acts on vehicles/pedestrians detected by the radar and camera sensors to reduce injuries due to collision, so it may not respond or its reaction may be delayed. The driver shall apply the brake as required instead of waiting for the AEB system to operate.

The AEB system cannot always clearly identify objects and complex traffic conditions. In these cases, the AEB system may:

- issue a warning or apply braking for no reason
- not issue any warning or not apply braking

Therefore, the driver shall always observe traffic conditions and shall not completely rely on the AEB system. The driver shall be fully responsible for keeping a proper distance from the vehicle ahead, controlling the speed and braking in time because the AEB system is just a driving assistance. The driver must always be ready to apply braking or steering.

5.4.6 Pedestrian detection system *

Based on the MMW radar installed on the front bumper and the IFC on the windshield, the pedestrian detection system detects pedestrians ahead and actively assists the driver in avoiding or reducing collisions with pedestrians within its operating range so as to lower the likelihood of accidents. The system issues an alarm for impending collision to alert the driver to the fact that the vehicle is ready to apply emergency braking, and then the system assists in braking and triggers the AEB.

NOTE

Precautions for use of radar and camera sensor. => [See page 185](#)

CAUTION

The pedestrian detection function cannot be substituted for a driver's attention during driving!

Proximity warning

If a potential collision with a pedestrian is detected, the system will alert the driver to actively apply braking through the audible warning and warning lamps on the instrument cluster when the speed is between 30 km/h and 64 km/h. The duration of warning is contingent on the practical traffic conditions and the driver's action. In addition, the vehicle is ready for applying emergency braking at any time.

Forward collision warning (FCW) system involves the proximity warning in the pedestrian detection function. For how to switch on/off the system, refer to the section on the FCW system. => [See page 170](#)

Active brake assist

If the driver does not respond to the alarm issued by the system, the pedestrian protection system may automatically apply full braking when the vehicle speed is between 8 km/h to 64 km/h. If a potential collision is detected, the system reduces the speed by braking to lower the likelihood of the collision.

5. Driving guide

The active brake assist function of the pedestrian detection system is covered by the AEB system. For the method to activate/deactivate the function, refer to the section on the AEB system. => [See page 172](#)

In order to activate this function accurately, it is necessary to obtain accurate information on pedestrians.

WARNING

The driver shall be fully responsible for the safety of the vehicle because this function cannot detect pedestrians under all conditions.

PDS fault indication

If the pedestrian detection function is faulty, the instrument cluster will display the message alert "Pedestrian detection function is not available" to the driver.

NOTE

- Because the pedestrian detection system cannot overcome the limitations of some physical conditions, the functions cannot be fully achieved when the vehicle runs in the speed range specified by the system. Therefore, the driver shall be responsible for timely applying effective braking. Whether the pedestrian detection system shall issue an alarm or whether the pedestrian detection system shall brake or avoid pedestrians with the help of the brake pedal is contingent on practical conditions.
- The pedestrian detection function cannot rely on the pedestrian detection system to completely avoid accidents or serious injuries.
- In case of some complex road conditions (such as curved main roads), the pedestrian detection function may respond to some targets of similar shape or size with pedestrians by unnecessarily issuing some alarms or unnecessarily intervening in braking.

NOTE

- When the pedestrian detection function is faulty, for example, due to inaccurate radar/camera sensor angle, there may be unwanted alarms or interventions in braking.
- If the pedestrian detection function activates braking, the driver will feel hard while depressing the brake pedal.
- When the driver depresses the accelerator pedal or turns the steering wheel, the automatic braking activated by the pedestrian detection function is interrupted.
- When the system gives an alarm, the system may have no time to help the driver in avoiding a collision.
- If the pedestrian detection function has the anomalies other than those described above (for example, the function has been activated abnormally for many times), please deactivate the pedestrian detection function and go to the GAC Motor authorized shop for inspection in time.



WARNING

- **The driver shall always be ready to take over control of the vehicle at any time.**
- **Never ignore the suddenly activated alarm lamp and reminder displayed on the instrument cluster, otherwise a traffic accident and even serious injuries may occur.**

System limitations

There are physical and system limitations to the pedestrian detection function. For example, in some cases, the pedestrian detection function may be unintentionally activated or have activation delay due to intervention by the driver. Therefore, the driver shall stay vigilant and take over control of the car if necessary.

The pedestrian detection function may be unintentionally activated or have activation delay when:

- The vehicle is running on a narrow curve.
- The accelerator pedal is depressed to the floor or the vehicle accelerates quickly.
- The assist function is deactivated or operates abnormally.
- The ESP function is manually deactivated.
- ESP control is activated for the vehicle.

- An intelligent forward camera or a radar sensor is dirty or blocked by foreign objects.
- The vehicle is reversing.
- Traffic is chaotic.
- The vehicle body is used to tow another vehicle.
- A pedestrian is standing on a refuge island or a curve.
- A pedestrian is completely or partially covered by other objects, e.g. a worker with a ladder.
- A pedestrian is wearing fancy clothes, such as the carnival costume.
- External conditions such as sunset, night, ice, snow, heavy rain, fog and backlight lower the visibility.

5.4.7 Lane keeping aid (LKA) system*

The lane keeping aid system is designed to reduce accidents caused by unconscious lane departure.

The lane keeping aid system detects the lane markings on the road and curbs through the intelligent front camera installed on the front windshield, and detects the road guardrails through the millimeter wave radar installed in the front of the vehicle. In addition, it analyzes the driver's driving behavior and vehicle movement status. When the driver unconsciously departs from the lane due to fatigue, distraction, or a phone call, the AEB issues a warning or intervenes in turning of steering wheel to assist in corrective steering adjustment. Generally, a warning will be issued or turning of steering wheel will be intervened in when the front wheels cross a lane marking or get beyond/crash a curb.



When the driver selects "Steering assist" or "Steering assist and warning" as the LKA mode and the operating conditions of the lane departure aid system have been met, the system monitors the torque applied to the steering wheel. When the driver keeps hands off the steering wheel for a long time, the system will alert the driver.

5. Driving guide

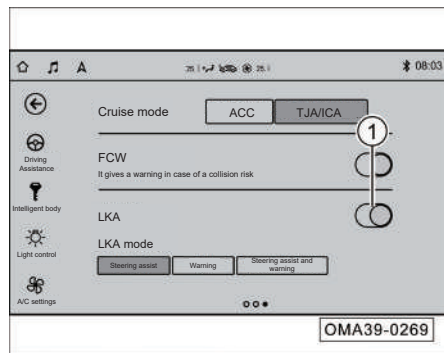
On and Off



When the ignition switch is set to “ON” position, go to “System Settings → Driving Assistance → LKA→” interface on the AV system display to briefly press the soft key  to the right of “LKA” so as to turn on/off the lane keeping aid system.

When the system is on, the soft key on the AV system interface is set to the “On” position and the status indicator  in the instrument cluster lights up; when the system is off, the soft key on the AV system interface is set to the “Off” position and the status indicator  in the instrument cluster goes out.

i NOTE

- The system has the button state memory function that keeps the button at the same state with the one before last shutdown when the vehicle has started.

Selecting LKA mode

When the ignition switch is set to the “ON” position and the LKA is switched on, click “System Settings → Driving Assistance → LKA” on the AV system display to select LKA mode.

1. Steering assist
 - When “Steering Assist” is selected, the system only intervenes in turning of steering wheel for corrective steering adjustment.
2. Warning
 - When “Warning” is selected, the system only issues a warning.
3. Steering assist and warning
 - When “Steering assist and warning” is selected, the system will not only issue a warning but also intervene in turning of the steering wheel for corrective steering adjustment.

i NOTE

The LDW has the lane keeping assist mode memory function, so that the lane keeping assist mode before last shutdown will be selected when the vehicle is restarted.

Warning alert

The LKA alert is triggered only when the assist mode is "Warning" or "Steering assist and warning".

When the instrument shows a speed greater than 65km/h and the system detects at least one valid lane marking on one side, the indicator lamp  on the instrument cluster lights up green. It indicates that the system may issue a lane departure warning in this case. When only the lane marking on one side is detected, the system only alerts the driver to the side with the lane marking.

When the indicator lamp  lights up green, the system will not issue a warning if the vehicle departs from the lane under one of the following conditions.

- The accelerator pedal is quickly depressed for acceleration.
- The brake pedal is depressed forcibly.
- Corresponding turn signal lamp is turned on.
- The hazard warning lamp is turned on.
- The lane is too narrow.
- The interval between two lane departure warnings is short.
- The vehicle is rolling on or crossing over the lane marking.
- The radius of the lane curve is less than 250 m.

When the indicator lamp  lights up green, no condition mentioned above happens and the vehicle accidentally departs from the lane, the system alerts the driver by displaying the flashing lane marking reminder on the instrument cluster, the indicator lamp turning yellow with beeping.

Steering assist

The corrective steering adjustment indication is activated only when "Warning" or "Steering and Warning" has been selected as assist mode. The steering assist is primarily the corrective steering adjustment.

When the instrument shows a speed greater than 65 km/h and the system detects valid lane marking on at least one side, The indicator lamp  on the instrument cluster lights up green. This indicates that the system may intervene in turning of steering wheel for corrective steering adjustment. In case of only one lane marking detected, the system only implement corrective steering adjustment for the side with the lane marking.

When the indicator lamp  lights up green, the system will not implement corrective steering adjustment under one of the following conditions.

- The accelerator pedal is quickly depressed for acceleration.
- The brake pedal is depressed forcibly.
- Corresponding turn signal lamp is turned on.
- The hazard warning lamp is turned on.
- The interval between two lane departure warnings is short.
- The lane is too narrow.
- The vehicle is rolling on or crossing over the lane marking.
- The system alerts the driver to take over the steering wheel because the steering wheel is out of the driver's hands.
- The radius of the lane curve is less than 250 m.

When the system intervenes in turning of steering wheel for corrective steering adjustment, the indicator lamp  lights up yellow. And the driver can feel the torque applied by the system to the steering wheel.

5. Driving guide

Hands-on reminder

When the lane departure warning system detects that the steering wheel is out of the driver's hands for a long time, the system issues a takeover indication while the instrument cluster displays an alarm message and beeps.

The driver shall immediately hold the steering wheel immediately after receiving the hands-on reminder and after detecting that the driver is holding the steering wheel, the system will cancel the hands-on reminder. The lane departure aid system is automatically reactivated.

i NOTE

The condition that the driver's hands are lightly holding on the steering wheel may be misinterpreted by the system as the steering wheel out-of-hand. In this case, it is only required to hold the steering wheel a little tightly or shake the steering wheel slightly.

Other indications

When the system detects that the camera is inoperative, the message "The lane keeping aid system is temporarily unavailable" pops up on the instrument cluster.

Usually, it is caused by dirty windshield glass or the camera directly exposed sunlight. The lane keeping aid system will not be damaged on that and it does not need to be overhauled.

The driver may try to clean the windshield glass by spraying water on it and activating the windshield wiper.

When the system detects a fault, the message "Please check the lane keeping aid system" pops up on the instrument cluster and the indicator lamp  lights up red.

i NOTE

If the message "Please check the lane keeping aid system" pops up on the instrument cluster, which indicates that the system is faulty, please go to the GAC Motor authorized shop for inspection in time.

Functional limitation

The lane keeping aid system may wrongly detect a lane marking or not detect any lane marking at all due to inevitable environmental factors and conditions even if the lane keeping aid system is activated and working. The system may be affected or inoperative under the following conditions:

- Poor line of sight caused by, e.g., snow, rain, fog or water spots.
- Dirty or foggy windshield, or obstruction in front of the windshield camera.
- Overtemperature around the camera due to direct sunlight.
- Glare due to direct sunlight, oncoming traffic, reflected light from road water-logging, etc.
- Sudden changes in outdoor brightness, such as entering/exiting tunnels.
- Headlamp not turned on at night or when the light is low in tunnels.
- No lane marking, or difficulty in distinguishing the lane marking color from the road surface color.

- Unobvious, too thin, worn, blurred or dirt/snow-covered lane markings.
- Too wide or narrow lanes.
- Increase or decrease of lanes, or complicated routing of lane markings.
- More than two lane markings on the left and right sides of the vehicle.
- Marks or objects similar to lane markings on roads.
- Isolation strips or other objects casting shadows on lane markings.
- Short-term change of marking, such as ramp or highway exit.
- Driving on steep slopes or curved roads.
- Close distance from the vehicle in front or lane markings blocked by the vehicle in front.
- Severe shaking of the vehicle.
- Fishbone-shaped (FS) markings with speed reduction sign.
- Red lane marking is on road due to road maintenance.

Under the following conditions, the performance of the system may be affected while it intervening in turning of steering wheel for corrective steering adjustment:

- Vehicle overload.
- Abnormal tire pressure.
- Uneven road.
- Strong crosswinds.
- Any part involved in vehicle control is modified or replaced with a non-genuine part.
- improper assembly of vehicle control-related parts.

CAUTION

- Do not color or coat the windshield with any material not meeting the corresponding specifications. Any additional objects that negatively affecting the sight of the system camera may lead to improper operation of the system.
- To ensure normal operation of the system, please make sure that there is no dirt, ice, snow or other obstructions on the top surface of the outside of the windshield.

CAUTION

- If the system camera cannot detect a lane or the speed is less than 65km/h, the system does not issue a warning even if the vehicle departs from or leaves the lane.
- The operation of the AV system in the vehicle or the noise outside the vehicle may prevent you from hearing the warning beeps. Thus, try to avoid these sounds and focus on observing the road conditions.
- Cracks, scratches, or damage by gravel in the front windshield area in front of the IFC view may make the lane keeping aid system deteriorated, unserviceable, or abnormal. It is recommended to replace the front windshield. Please contact GAC Motor authorized shop to ensure that the correct front windshield is installed.

5. Driving guide

WARNING

- The lane departure aid system is just an assist system and cannot actively control the vehicle to change lane or keep it in the lane. It is the full responsibility of the driver for always observing the road conditions and actively controlling the vehicle. The driver shall always hold the steering wheel tightly and actively control the vehicle.
- Improper use of the lane departure aid system or negligence may cause an accident. Do not rely on the lane departure aid system completely or drive the vehicle at risk with the aid of the LKA system.
- Do not place reflective objects on the instrument panel, which are not only easy to dazzle the driver but also may reflect the light to the system camera, causing abnormal operation.

WARNING

- Protect the system camera against strong impact, moisture or heat; and it is forbidden to remove and refit any part without authorization.
- When the lane keeping aid system intervenes in turning of the steering wheel for corrective steering adjustment, the driver may still turn the steering wheel to control the vehicle. When the driver feels an implausible torque applied to the steering wheel by the system, the driver may take over control of the vehicle at any time to drive it at will.
- When the lane keeping aid system detects an unintentional lane departure, it issues a warning or intervenes in turning of the steering wheel to assist in corrective steering adjustment. Don't panic or turn the steering wheel fiercely.

WARNING

- When the lane keeping aid system detects that the steering wheel is out of the driver's hands for a long time, it issues a warning. In this case, don't panic or turn the steering wheel fiercely. Just hold the steering wheel and drive the vehicle as usual.
- The lane keeping aid system is not always able to identify lane markings. Lane markings may be omitted due to adverse weather, poor night lighting, water and snow on road surfaces, damage and blurs of lane markings, etc. Specific objects and structure may be mistaken for lane markings due to road surface damage, water and snow on curb, other road structure and road surfaces, shadows cast on road surfaces, etc. This may cause missing and false activation of the function, so drivers shall concentrate on observing road and traffic conditions and drive carefully.

5.4.8 Intelligent high beam *

The intelligent high beam system detects the traffic and environmental conditions in real time via an intelligent forward camera sensor and it can automatically switch between the low beam and high beam. For example, the vehicle driver activates the intelligent high beam in case of driving on a road with poor lighting at night. When the system detects that the operating conditions of high beam are met, the high beam is automatically switched on; when the system recognizes that another vehicle traveling in the opposite direction or a following vehicle is approaching to this vehicle, it automatically switches from high beam to low beam.

i NOTE

In the case of heavy fog, rain, etc., which may dazzle the driver, the low beam is required to be activated.

⚠ WARNING

Intelligent high beam is a driving assistance, which can help you in using the lamp in the best way under suitable conditions. The driver shall always be responsible for manually switching between the high and low beams when the traffic and environmental conditions require.

- **The intelligent high beam may not be able to correctly identify all driving environments and cannot operate properly in some environments.**
- **If the intelligent forward camera is blocked by dirt, stickers, ice and snow, etc., the intelligent high beam may be inoperative.**
- **If the vehicle's lighting system is modified (for example, the headlights are modified), the performance of the intelligent high beam may be degraded or its function may be inoperative.**
- **When this vehicle is about to meet a non-motor vehicle (such as, a bicycle or an electric bicycle) or a pedestrian, the intelligent high beam system shall be de-activated in time to avoid dazzling the driver of the non-motor vehicle or the pedestrian.**

Activating intelligent high beam*

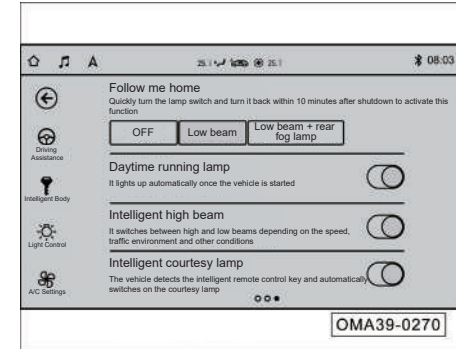







1. When the ignition switch is set to "ON" position, click "Vehicle Settings → Light control →IHC" on the AV system display, and press the soft key  to set the IHC to "ON".

i NOTE

The setting has a memory function that keep itself at the same state with the one before last shutdown when the vehicle has started.

5. Driving guide

2. Switch the lamp switch to AUTO position to switch on the “Automatic headlamp on/off”.

 - The intelligent high beam function is on standby since it has been activated, and the indicator lamp  on the instrument cluster does not light up.
 - When the low beam is switched on by the automatic headlamp on/off, the intelligent high beam function is activated and the indicator lamp  on the instrument cluster lights up white.
 - When the intelligent high beam function is activated and the high beam is requested to be switched on, the indicator lamp  on the instrument cluster stays on white and the high beam indicator lamp  lights up.
 - When the driver manually switches on the high beam or the headlamp flashing light, the IHC is ready for working, the indicator lamp  on the instrument cluster goes out and the indicator lamp  comes on.

Switching off intelligent high beam

- Switch the lamp switch to a position other than AUTO.
- Go to “Vehicle Settings → Light control → Intelligent High Beam” on the AV system display, and press the soft key  to set the intelligent high beam to “OFF”.
- Switch on the high beam manually.
- Shut down the engine.

NOTE

- When this vehicle is about to meet a non-motor vehicle (such as a bicycle or an electric bicycle), the function shall be de-activated in time to avoid dazzling the driver of the non-motor vehicle.
- The high beam and headlamp flashing can be manually switched on/off at any time.

Conditions for inhabiting intelligent high beam

The high beam is inhibited when:

- The instrument cluster shows a speed lower than 15km/h.
- The fog lamps have been turned on or in a rainy or foggy day.
- The windscreen wiper has been set to “HI” position for a period of time.
- The ambient light is bright.
- A street light, a vehicle ahead or an oncoming vehicle is detected.

Switching between high and low beams is inhibited when:

- The lateral acceleration or yaw velocity is too high.
- The vehicle is at the highly dynamic state (ABS or ESP active).
- The instrument cluster shows a speed lower than 35km/h.
- Turn signal lamp is turned on.

Functional limitation

When the intelligent high beam is used as an assist, the intelligent headlight control (IHC) may be delayed or even unavailable due to the following:

- The intelligent front camera is covered with ice, snow, fog, dirt, sticker or other objects.
- There is highly reflective object on a low-lit street.
- The vehicle meets a pedestrian or a cyclist on a road with poor lighting or on a roadside.
- The light of the front oncoming vehicle is blocked by a crash barrier, a high bow-top road fence, a green belt, etc.
- The brightness of the tail lamps of the vehicle ahead is low or does not comply with national standards when the vehicle is following the vehicle ahead.
- The vehicle meets another oncoming vehicle in case of an extremely tight turn/mountain road/low-lying ground.
- The vehicle is driving on a slope or a bumpy road.
- The vehicle is driving in a heavily rainy, snowy or foggy day. The intelligent forward camera is damaged or its power supply has been cut off.

5.4.9 Radar and camera sensors *

Special instructions on radar and intelligent front camera (IFC) sensor

Front radar sensors are installed in front of the vehicle so no obstacle is allowed in the sight of the radar sensor. If you are about to install a front license plate, do not install a large license plate frame that may block the front radar sensors, otherwise the front radar sensors may be blocked by the obstacles such as the license plate frame, as a consequence, the adaptive cruise control system, forward collision warning system, autonomous emergency brake and pedestrian detection function may not work.

The IFC sensor is installed on the upper part of the windshield and no other obstruction is allowed to be in the field of view of the sensor.

i NOTE

- Special tools and equipment are required to be used in adjustment and calibration of a radar sensor. If adjustment and calibration of the radar is required, it is recommended to go to the GAC Motor authorized shop for relevant operation.
- When the radar sensor has a failure or maladjustment, it may affect the normal operation of the functions such as the adaptive cruise control system, FCWS and AEB.
- Special tools and equipment are required to be used in calibration of the forward camera. If calibration of the camera sensor is required, please go to the GAC Motor authorized shop for relevant operation.
- In case of failure, maladjustment or blocking of the forward camera, the system functions of the ACC, FCWS, AEB and lane departure warning may be affected and not work properly.

5. Driving guide

Radar sensor

The radar sensors are installed in the middle of the grille under the front bumper to monitor the traffic conditions and detect the front vehicles at a certain distance from the vehicle.

A radar sensor must be adjusted and calibrated under the following conditions:

- The fixing bracket of the radar sensor is removed and refitted;
- The radar sensor is removed and refitted;
- The toe-in or rear wheel camber has been adjusted during the four-wheel alignment;
- The vehicle has a collision.

i NOTE

- If the radar sensor is dirty or blocked by the license plate frame, or the bumper area, at which the radar is installed, is covered by any foreign matter such as heavy rain, ice, snow, mud, the functions dependent on the radar sensor may not work and the instrument-related functions are disabled and/or have fault indication. The functions can return to normal by clearing off the dirt and/or foreign matters.
- Repairing the front vehicle body or bumper of the vehicle may change the direction of the radar sensor, which may affect the functions dependent on the radar. Thus, it is recommended to go to the GAC Motor authorized shop for repair in time.

i NOTE

- If a radar sensor is damaged or its direction changes, please deactivate the functions dependent on the radar (e.g., ACC/FCW/AEB), and it is recommended to go to the GAC Motor authorized shop for recalibration in time.
- Direction of a radar sensor may be changed due to vibration, for example, when the part near the front bumper radar bumps against a curb/flower bed or a bumper bumps against something. Changing the direction of the sensor may affect the performance of the functions dependent on the radar or even lead to abnormal shutdown of the system.
- It is recommended to remove the snow on the sensor with a brush and to remove the ice on the surface of the sensor with the insoluble de-icer spray.

Intelligent forward camera sensor

An intelligent forward camera is installed above the front windshield to detect the surrounding environment and objects. The camera can identify a pedestrian standing up to 80 m away from the vehicle when no obstacle blocks it (in case of the environmental factors such as lighting is ideal). The minimum pedestrian detection height of the camera is 0.8m.

The forward camera sensor must be calibrated under the following conditions:

- The windshield or the camera bracket has been removed and replaced.
- The forward camera sensor has been removed and replaced.

CAUTION

- Poor lighting conditions, night, backlight and heavy rain may affect the intelligent forward camera, leading to function interruption or reduced performance of the ACC, FCWS, AEB, lane keeping aid system and intelligent high beam system. In severe cases, the functions will be completely disabled and the instrument cluster will display the prompt and alarm messages such as “Please check the lane keeping aid system”, “Please check the ACC system”, “Please check the FCWS”, “Please check the AEB system” and “Pedestrian detection system is not available”.

CAUTION

- Obstacles such as dust, sediment, mist, ice, snow or sludge on the windshield glass may reduce the sight of the intelligent forward camera while the systems such as ACC, FCWS, AEB, lane keeping aid system and intelligent high beam are disabled. In this case, please wipe the area around the IFC on the windshield glass or activate the A/C defrosting, and then the function will return to normal when the obstacles are removed.
- The camera cannot recognize animals and short pedestrians.
- Before driving the vehicle, please check whether there is any obstacle in the area around the camera.
- Keep the sight of the IFC sensor clear.

5. Driving guide

5.4.10 Tire pressure monitoring system (TPMS)

The TPMS monitors pressure and temperature of the tire, and displays the current pressure and temperature of the tire on the instrument cluster. In case of tire anomalies such as low/high pressure, rapid air leakage and high temperature, the instrument cluster will display various alarm messages.

When the ignition switch has been set to the "ON" position, the tire pressure and temperature displayed on the instrument cluster are both "----" if the vehicle is stationary or the vehicle speed does not exceed 25km/h. If the vehicle speed has been above 25km/h, the current tire pressure and temperature are displayed on the instrument cluster.

The TPMS alarms include the fault indicator lamp and the message alarms. The alarms consist of the low/high pressure alarm, rapid air leakage alarm and high temperature alarm.

- When the tire pressure is too high, the fault indicator lamp will come on, the LCD screen of the IP will display a message alarm "Tire pressure is high", and the position lamp will flash to indicate the corresponding tire position.

- If the tire pressure is lower than 172.5kPa, the indicator lamp of the TPMS lights up and the alarm message on the instrument display indicates that the tire pressure is low.
- If the decreasing rate of the tire pressure is higher than a specified level, the TPMS indicator lamp lights up and the alarm message on the instrument display indicates that the tire has air leakage.
- If the tire temperature is higher than 85°C, the TPMS indicator lamp lights up and the alarm message on the instrument display indicates that the tire temperature is high.

CAUTION

- Some electronic add-ons may make the TPMS unable to operate normally.
- If the tire pressure sensors in the tires or the tires are required to be replaced or rotated, it is necessary to learn about how to match the tire pressure sensors in the four tires. In this case, please go to the GAC Motor authorized shop for replacement.

NOTE

- If the low tire pressure alarm does not disappear while you continue to drive as the tire pressure sensor is missing when a spare tire or a new tire has been replaced in another place. Please do not interpret that as abnormal tire pressure.

i NOTE

- Standard half-loaded tire pressure is used as the normal setting value for the reference of the TPMS alarm.
- In case of the tire anomaly such as high temperature, low/high pressure and rapid air leakage, the instrument cluster will display various warning messages and cyclically display the position of the corresponding faulty tire; when the TPMS has a fault, the instrument cluster will give warning and cyclically display "Please check the TPMS".
- When a high temperature alarm is activated, it is recommended to have a rest stop and wait for the tire temperature to decrease before continuing to drive.
- If the driving alarm record has not been cleared after parking, the alarm message will be shown and the pressure and temperature will be shown as "---" on the display for next driving; however, when the vehicle speed is higher than 25km/h, the receiver will receive the updated data and the alarm message will disappear.

5. Driving guide

5.4.11 Particulate filter

The particulate filter is used to:

capture the particles from the exhaust gas to reduce the emitted particles, thus reducing air pollution.

Instructions on particulate filter indicator on:

- If the indicator lamp on the instrument cluster lights up white and the message “Please run at high speed for regeneration” pops up, it indicates that the number of particles in the particulate filter has reached a certain load level and the user should perform particulate filter regeneration. It is recommended to drive at a vehicle speed above 80km/h for at least 30 minutes while keeping the engine running; if it fails, the indicator will continue to light up and the message will continue to be displayed as the particles accumulate further.
- If the indicator lamp on the instrument cluster lights up yellow and the message “Please visit a 4S shop for maintenance” pops up, it indicates that the number of particles in the particulate filter is close to the upper limit and the user shall drive the vehicle to the GAC Motor authorized shop for maintenance.

i NOTE

- If more and more particles accumulate in the particulate filter, it will cause the exhaust back pressure to rise and the fuel consumption to increase, which degrades the engine performance. Therefore, it is necessary to timely burn the particles via oxidization.
- Ignoring the lit indicator of particulate filter and related warning description may cause the particulate filter to be overloaded and damaged.

5.5 Parking assist system (PAS)

5.5.1 Reversing parking aid (RPA)

The reversing parking aid (RPA) measures the distance with an obstacle via the 3 radars on the rear bumper sending and receiving ultrasonic waves reflected from the obstacles.

On and Off

- When the vehicle runs at a speed not greater than 10km/h with EPB released and gearshift lever set to "R" position, the RPA will start working.
- When the vehicle speed is greater than 12km/h or the gearshift lever is set out of "R" position with EPB applied, the RPA will stop working.

Dynamic view

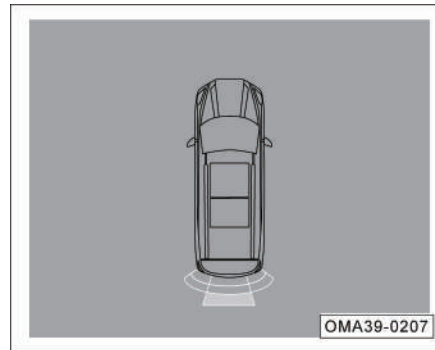

The dynamic view on the display indicates the distance between the vehicle and an obstacle. In the view, the outermost sector is orange, the middle & innermost sectors gradually turn to orange and red. When the vehicle is getting closer and closer to an obstacle detected, the colorful sectors will gradually decrease from the outermost sector.

Change of dynamic view is synchronized with that of the audible alarm with reference to distance.

5. Driving guide

Distance to detected obstacle			Audible alarm
Rear left sensor	Rear right sensor	Rear middle sensor	
90 ~ 120cm	90 ~ 120cm	90 ~ 150cm	Regular slow audible alarm
60 ~ 90cm	60 ~ 90cm	60 ~ 90cm	Regular slow audible alarm
30 ~ 60cm	30 ~ 60cm	30 ~ 60cm	Regular rapid audible alarm
< 30cm	< 30cm	< 30cm	Continuous audible alarm

Audible alarm with reference to distance

The audible alarm changes with reference to the distance between a detected obstacle and the rear bumper. In addition, the color of activated sectors shown on the AV system display changes accordingly. If the vehicle approaches an obstacle, the system sends an intermittent audible alarm to the driver. The closer the vehicle to the obstacle is, the briefer the audible alarm becomes; the system sends a continuous audible alarm when the vehicle is very close to the obstacle. If the vehicle goes on approaching the obstacle in this case, the system cannot detect the obstacle any more.

Distribution of radar sensors

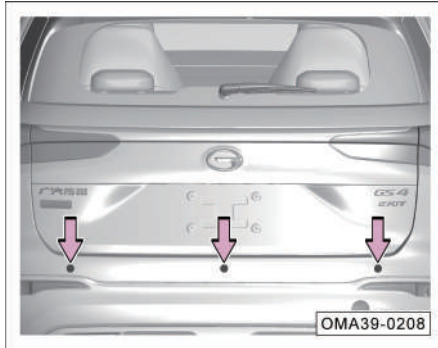

The radar sensors are installed on the rear bumper cover.

CAUTION

- Always keep the surface of the RPA sensors clean and never cover a RPA sensor.
- Keep the RPA sensors on the bumper clean and protect them from freezing to ensure the RPA sensors operate properly.
- Clean the RPA sensor surface with a piece of soft damp cloth to avoid scratching it.

WARNING

- The reversing parking aid cannot be substituted for the driver to observe the surrounding environment. The driver shall focus on safely reversing according to the practical conditions.
- The radar sensors have blind spots while they detecting obstacles. During reversing, the driver shall observe the surrounding environment carefully to avoid an accident.
- When the vehicle is reversing at a narrow place or on an uphill slope, the RPA sensors may not detect railings, trees or slope surfaces, which is normal.
- When the reversing speed is high, the accuracy of the RPA sensor detection reduces. Thus the reversing speed had better not to exceed 10km/ when the RPA sends the continuous audible alarms, it indicates that the vehicle is extremely close to the detected obstacle, and reversing shall be stopped immediately to prevent an accident.

5. Driving guide

WARNING

- During cleaning a radar sensor with a high-pressure cleaner, clean it gently in snatches and the nozzle shall be at least 30cm away from the sensor.
- If water drops are attached to the surface of the RPA sensor on the rear bumper, the sensitivity of the sensor will reduce. Wiping off them can restore the sensitivity of the radar.
- The surface of some materials cannot reflect the signal from the RPA sensor, so that the RPA sensor cannot detect such materials or people wearing the clothing made of such materials.
- Noise sources outside the vehicle may interfere with the RPA sensor, preventing it from detecting any target.
- The RPA sensor is a precision component, which shall not be removed, refitted and repaired without authorization. The company does not assume any responsibility for the damage caused by unauthorized removal & refitting and repair.

5.5.2 Reverse image system *

The reverse image system can film at a wide angle up to 130° and display a wide-range image behind the vehicle on the AV system display so as to help the driver to observe complex road conditions behind the vehicle and improve the safety of reversing.

On and Off

In case of the ignition switch set to the "ON" position, the reverse image system automatically starts to operate if the gearshift lever is moved to the "R" position. In this case, the AV system display begins to show the image behind the vehicle and displays the reversing guideline in the reverse image.

If the gearshift lever is move out of the "R" position, the reverse image system automatically stops operating and the AV system exits from the reverse image.

WARNING

Reverse image system cannot take the place of the driver's observation of the surrounding environment. The driver shall focus on safely reversing and position adjustment according to the practical conditions.

Dynamic trajectory

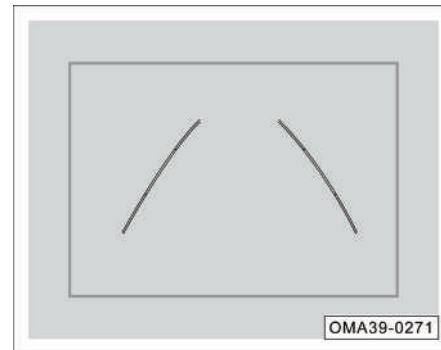

The reversing guidelines shown on the display may change direction with the steering wheel turned so as to indicate the driving route of the vehicle at different steering wheel angles.

NOTE

All above-mentioned reversing guidelines are reference vehicle trajectories obtained by testing on a flat ground. In case of driving on a slope, the above trajectories cannot be used as accurate reference.

Backup camera

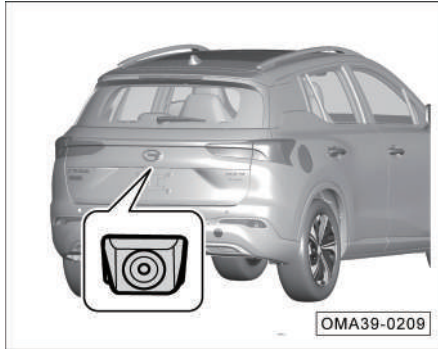

It is installed next to the license plate lamp.

WARNING

- **The backup camera has blind spots because the camera may not detect young children or small pets. It is important to pay special attention to the young children or small pets around the vehicle during reversing.**

WARNING

- **The backup camera may not be able to recognize the vertical objects at high position.**

CAUTION

- Always keep the backup camera surface clean. Clean the surface of the backup camera with a piece of soft damp cloth to avoid scratching it.
- Do not use a high-pressure cleaner to clean the backup camera for a long time. The cleaner nozzle shall be at least 30 cm away from the backup camera during cleaning.
- Do not cover the backup camera.

5. Driving guide



5.5.3 Around view monitor (AVM)*

The AVM consists of one control unit and four 180° cameras. The control unit collects the left, right, front and back images of the vehicle and integrates them into a 360° bird's-eye view of the surrounding environment, which is displayed on the AV system display to provide the driver with information on the surrounding environment of the vehicle and to reduce blind spots during driving. In addition, it can take the parameters such as steering wheel angle and vehicle dimensions into consideration to predict the vehicle's motion trajectory as well as superimpose the predicted track on the panoramic image to provide the driver with full information on the vehicle's direction of traveling, helping the driver to determine whether it is safe to reverse.

On and Off

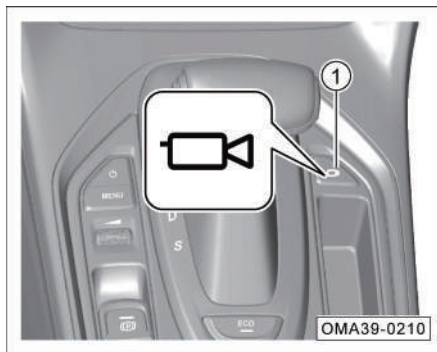
1. In case of the ignition switch set to the "ON" position, the system can be activated/deactivated via the gearshift lever:
 - Set the gearshift lever to "R" position, and the AVM is activated automatically.
 - When the gearshift lever is moved out of the "R" position and the driver do not carry out any relevant operation, the AVM will be deactivated automatically after 30s.



2. In case of the ignition switch set to the "ON" position, the system can be activated/deactivated via pressing button:
 - Short press button ① , the button indicator lamp lights up, which indicates that the system has been activated.
 - Short press button ①  again, the button indicator lamp goes out, which indicates that the system has been deactivated.

i NOTE

- When the AVM has been activated, the AV system display shows the image around the vehicle and some reversing guidelines.
- If the forward speed is greater than 20km/h, the AVM will be automatically deactivated.
- When the gearshift lever is not in the "R" position and the system has been activated for more than 30s, the system will be automatically deactivated (when the speed is zero).
- If the AV system is not completely activated, the AVM cannot function properly.

Interface description

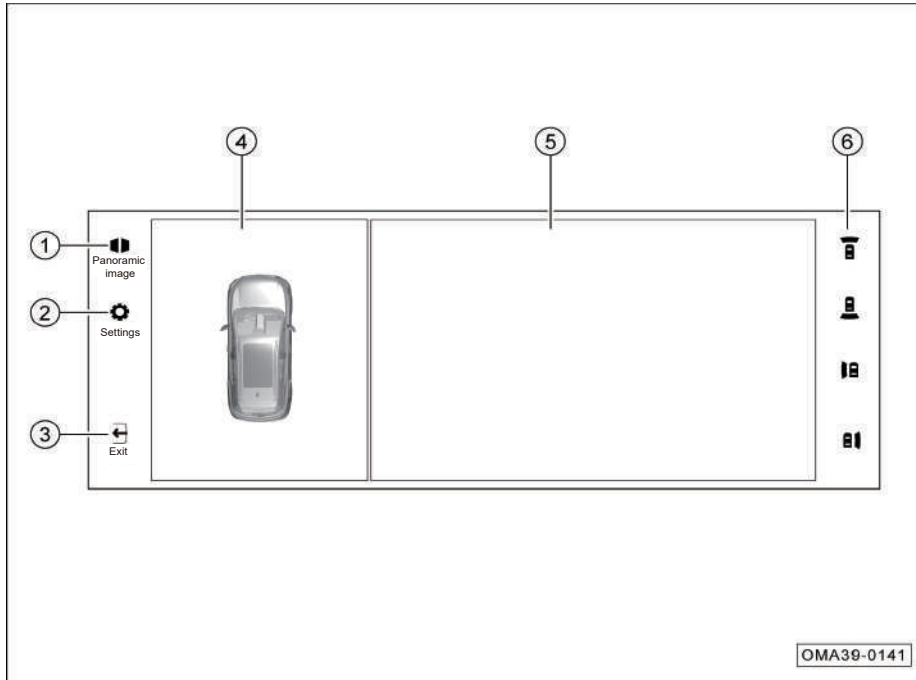

- ① Panoramic image button
- ② Setting button
- ③ Exit button
- ④ Integrated view section
- ⑤ Single view section
- ⑥ Viewing angle switching button

5. Driving guide

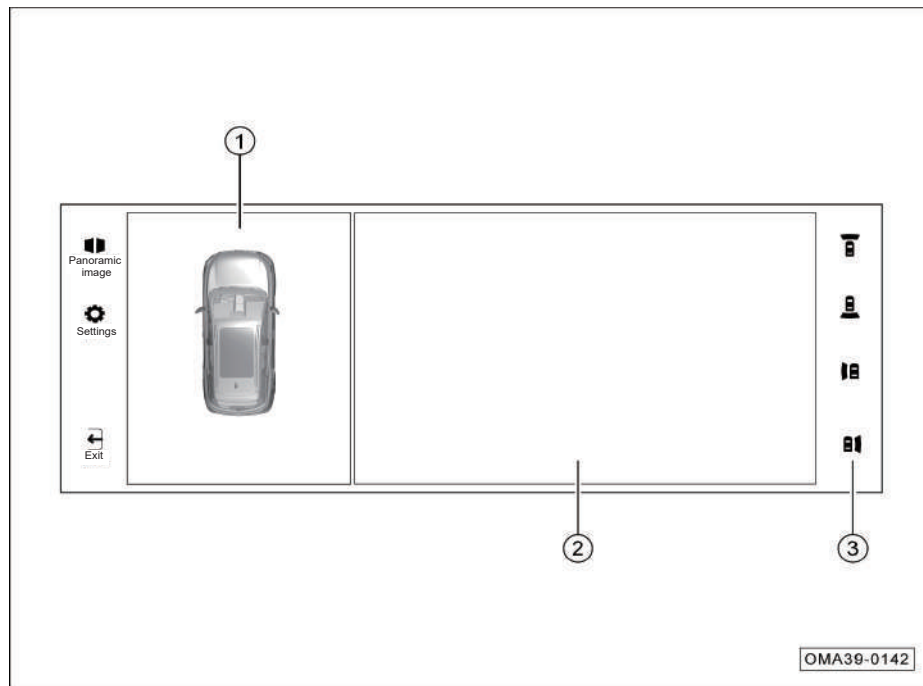

When the system starts to work, the display shows the panoramic image view interface:

- When the front/back/left/right area in the integrated view section ① is clicked or the soft key ③, which is used to switch among the front/back/left/right surrounding environment view of the vehicle, has been pressed, the single view section ② displays the front/back/left/right surrounding environment view of the vehicle accordingly.

i NOTE

- The description of display interface is for reference only. If there is a difference with the display interface in the actual vehicle, the one on the vehicle shall prevail.
- Click the panoramic image button to switch to the panoramic image view interface.
- When the gearshift lever has been moved to "R" position, the back view interface is shown by default; when the gearshift lever has been moved out of the "R" position, the front view interface is shown by default.

Distribution of cameras

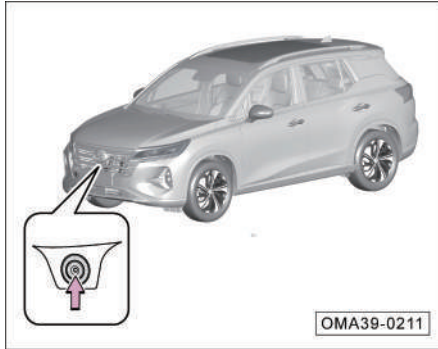

Front camera is installed under the vehicle logo, which is in the middle of front grille.

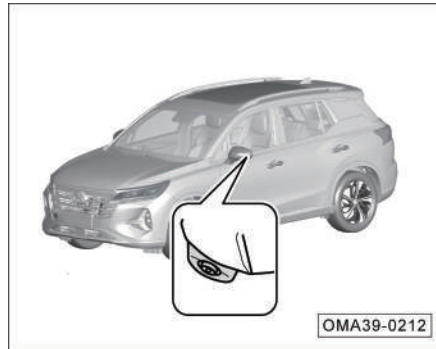

Left & right cameras are installed on the left & right exterior rearview mirrors.

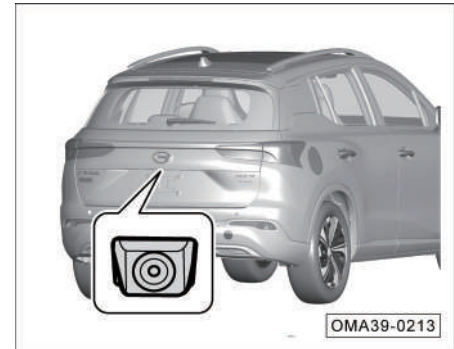

Backup camera is installed next to the license plate lamp.

CAUTION

- Please keep the camera surface clean.
- Do not use a high-pressure cleaner to clean the camera for a long time. The cleaner nozzle shall be at least 30 cm away from the camera during cleaning.

5. Driving guide

5.6 Electric power steering (EPS)

The electric power steering (EPS) is a power steering system which directly uses the torque provided by the motor. It is mainly composed of a torque sensor, a motor, a retarding mechanism and an electric power steering control unit (ECU).

The electric power steering control unit (ECU) controls the torque provided by the EPS motor in real time by detecting the torque applied by the driver, the vehicle speed, the engine speed and other status signals of the vehicle to augment the steering effort in the best way so as to ensure the convenience of steering at a low speed and the stability of steering at a high speed, and to improve the driving comfort and vehicle safety.

Electric power steering (EPS) indicator lamp

In case of the ignition switch set to the "ON" position, the indicator lamp  lights up. The system performs the self-test a few seconds after the engine is started and the indicator lamp goes out, which indicates that the EPS works properly.

If the indicator lamp  lights up when the engine has been started or while driving, it indicates that the EPS is faulty. In addition, the instrument cluster displays an alarm message. In this case, the vehicle shall be parked in a safe place. Try to shut down and restart the engine. If the indicator does not go off or light up again while driving, do not drive the vehicle any more, instead, please contact the GAC Motor authorized shop for inspection.

Steering mode

There are three steering modes: Standard, Sport and Comfort modes, where the hand force of the driver turning the steering wheel in Sport mode will be a little greater than that in the Standard mode, and the hand force in Comfort mode will be a little smaller than that in the Standard mode, and the system is set to the Standard mode by default. It can be set by going to "Vehicle Settings → Driving Assistance → Steering Mode" on the AV system display.

CAUTION

To prevent an accident, never set the steering mode during driving.

5.7 Driving skills

5.7.1 Driving safety inspection

Routine inspection

- Check the tire pressure; check the tires for cuts, bulges, damage or excessive wear.
- Check whether the wheel studs are missing or loose.
- Check whether the front & rear combination lamps and other lamps work properly; check the lighting direction of the front combination lamp.
- Check that the seat belt is not worn or damaged; check that the seat belt is fastened securely after seat belt fastening.
- Check that the free travel of the pedal is sufficient.
- Check whether the levels of coolant, engine oil, brake fluid and windshield washer fluid are normal.
- Check the battery terminals for corrosion or looseness and check the battery shell for cracks or deformation caused by expansion.
- Check for leakage of fuel, engine oil, water or other liquids under the vehicle. Any water found after A/C operation is normal.

After starting/during driving

- Observe whether the instrument cluster works properly; check whether any indicator lamp lights up or any alarm message is shown, etc.
- Check whether all controls (such as the lamplight combination, wiper combination and defrosting switches) work properly.
- The vehicle shall not be biased to a side when the braking condition is checked and confirmed on a safe road.
- For other anomalies, check for loose parts, leakage, and abnormal noise.

i NOTE

In case of any anomaly, please contact the GAC Motor authorized shop for inspection.

5.7.2 Driving during running-in period

In order to prolong the service life of the vehicle, the vehicle shall have a running-in for the initial stage of its operation before it is brought into use. Please comply with the following rules for your vehicle in the running-in period:

- The running-in period shall be 1500km.
- Choose a road in good condition and drive it at reduced load and limited speed during the running-in period.
- Do not start the engine with full throttle or drive with harsh acceleration.
- Avoid emergency braking in first 300 km.
- Strictly follow the operating procedures and make sure that the engine has reached normal operating temperature. Do not change the oil before regular maintenance.
- Carry out daily maintenance of the vehicle carefully; check and tighten the external bolts and nuts frequently; check the sound and temperature changes of the assemblies generated by operation and adjust them timely.

5. Driving guide

Engine running-in

The running-in period of a new engine shall be 1500km. In case of the distance driven < 1000km:

- The vehicle speed shall not exceed 3/4 of the maximum allowable speed.
- Do not drive the vehicle with full throttle.
- Avoid running the engine at high speed.
- Do not tow any trailer.

In case of the vehicle's driven distance between 1000km-1500km, the engine & vehicle speeds can be gradually increase to those not higher than maximum allowable engine & vehicle speeds.

The internal frictional resistance of the engine at the initial stage of running-in is much greater than that after running-in, and all the moving parts of the engine can have the best fitting after running-in.

After fully running in, both the service life and the fuel efficiency of the engine can be improved.

Running-in of tire and brake lining

If the driven distance of a new vehicle is not greater than 500km, the vehicle shall be driven at a moderate speed and the new tires shall be run in fully.

If the driven distance of the new vehicle is between 200km-300km, the brake linings have not had optimal friction, so the vehicle shall run at a low speed and emergency braking shall be avoided as much as possible.



WARNING

- **New tires and brake linings without running-in do not have the best adhesion and friction. Therefore, drive the vehicle cautiously within the first 500km to get the tires fully run in to prevent accidents.**
- **Replaced new brake lining shall be run in according to the above requirements as well.**
- **During driving, keep an appropriate distance from other vehicles to prevent emergency braking because new tires and brake linings have not been fully run in at this time. In case of an emergency braking, a traffic accident is likely to occur.**



WARNING

- **If a brake is wet or icy or the vehicle travels on a salted road, the braking effect will be reduced.**
- **Brake shall be applied according to road and traffic conditions; do not depress the brake pedal when it is unnecessary; otherwise the brake will overheat due to friction, resulting in a too long braking distance, which leads to excessive brake wear.**
- **Do not shut down the engine for coasting. Otherwise the brake booster does not work and the braking distance greatly increases, which is very easy to cause an accident.**

5.7.3 Driving essentials

Precautions under various road conditions

- When the vehicle is driving on a road with crosswinds and gusts, the driver shall decelerate in advance and control the speed and steering wheel.
- The vehicle shall avoid rolling on sharp-edged objects or other road obstacles, otherwise it may cause serious damage such as tire burst.
- Reduce the speed and drive at a low speed while driving on a bumpy or uneven road; otherwise the chassis may be scratched, which result in vehicle damage.
- When the vehicle is driving downhill, decelerate in advance; avoid emergency braking, otherwise the brake system will overheat or be worn out too quickly.
- When the vehicle is running on a slippery road, be careful during accelerating or braking; avoid sudden acceleration or emergency braking; otherwise, it is likely to cause wheel slip.
- The vehicle shall be driven at a low and constant speed on an icy and snowy road; avoid sudden acceleration or emergency braking and install tire chains for the wheels as needed.

Precautions while driving over a water-logged road section:

1. Before driving over a water-logged road section, check the depth of water, and the water level shall not be high than the lower edge of the vehicle body.
2. To drive through water, switch off the A/C before the vehicle starts, decelerate slowly and then gently depress and hold the accelerator pedal to drive over the water-logged road section at a stable and low speed.
3. Stopping the vehicle, reversing or shutting down the engine in water are all prohibited.
4. After successfully driving over the water-logged road section, it is important to gently depress the brake pedal for several times to evaporate the moisture on the brake discs so as to restore the usual braking performance as soon as possible.

5. Driving guide

i NOTE

The brake linings and brake discs are soaked in water while the vehicle is washed or driving over a deep water road, and the braking effect will be greatly reduced after the brake is applied; the braking distance will be longer than usual and the vehicle may be biased to one side, thus applying the parking brake may not brake the vehicle. In this case, drive the vehicle at a low speed and consecutively depress the brake pedal slightly to remove residual moisture in the brake. When the braking effect has returned to normal level, drive the vehicle as usual.

Driving essentials in winter

1. Proceed as below to check if the coolant is in good condition and if it is well protected from freezing:
 - Fill the cooling system with the same type of coolant as the one used in the vehicle according to the ambient temperature.
 - Filling the coolant other than that designated by the manufacturer may cause damage to the engine.
2. Proceed as below to check the battery and cables:
 - Stored energy of the battery decreases in very cold days. Therefore, fully charge the battery for start-up in winter.
3. Proceed as below to prevent the door lock from being frozen by ice and snow:
 - Spray some de-icer spray or glycerin into the door lock hole to prevent the door lock from being frozen.
4. The washer fluids containing antifreeze shall be used:
 - These products are available at GAC Motor authorized shop.
 - The mix ratio of water to antifreeze shall comply with the manufacturer's instructions.
5. No accumulated ice and snow shall be found beneath the mudguard:
 - Because accumulated ice and snow beneath the mudguard may result in difficult steering. Stop the vehicle regularly to check for accumulated ice or snow beneath the mudguard while driving the vehicle in severe cold winter.
6. According to different road conditions, it is recommended to bring several necessary emergency items such as:
 - Tire chains, a window scraper, a bag of sand or salt, a flashing light, a plough staff, connecting cables, etc., which are recommended to be placed in the vehicle.

7. In cold winter (especially in northern China), avoid starting the engine frequently and shutting down the engine immediately after a short-time start. If the engine is often in an alternating heat & cold cycle, the condensed water is likely to form in the engine. Condensed water adhering to the engine oil (where applicable) may give an illustration of water-in-oil emulsion. When the engine has been restarted and warmed up, this illusion will be shattered; in addition, please change the oil regularly as required by the Warranty Manual.

5.7.4 Efficient use of vehicle

- Before driving, make sure that the parking brake is completely released and the parking brake indicator lamp is off.
 - Maintain sufficient tire pressure as insufficient tire pressure can cause tires to wear out quickly and waste fuel.
 - Ensure the wheel alignment is accurate. Otherwise tires will wear out quickly, and the engine load will increase, causing fuel wasted.
 - Do not overload the vehicle. Unload unnecessary items from the vehicle as excessive load increases the engine load and wastes fuel.
 - Accelerate the vehicle slowly and smoothly to avoid rapid acceleration.
 - Avoid roads with traffic jams as much as possible as traffic jams waste fuel.
 - Observe traffic lights or maintain a safe distance with other vehicles while driving to avoid unnecessary stop or emergency braking so as to save fuel and reduce wear on the brake system.
- Do not step on the brake pedal when the vehicle is running, for fear of premature wear and overheating of brake pads and waste of fuel.
 - When driving, select good road surface. If driving on uneven roads, control the vehicle speed to avoid collision or scratches.
 - If the chassis is stained with objects such as excessive dirt, clean them in time to not only reduce the vehicle's weight but also prevent corrosion.
 - Perform regular maintenance on the vehicle to maintain its optimal working condition. Dirty air filter, spark plugs, oil, and grease will reduce the engine performance and waste fuel.
 - Drive slowly for a few minutes after starting the engine at low temperature, and ensure the engine is warmed up before acceleration.
 - Do not open windows when driving at high speed.
 - Properly use the A/C, etc.
 - In case of parking for a long time, please shut down the engine to avoid wasting fuel due to long time idling of engine.

5. Driving guide

5.7.5 Fire prevention

In order to prevent vehicle fires, pay attention to the following during use:

1. It is forbidden to store flammable or explosive items in the vehicle;
 - In hot summer days, the internal temperature of vehicles parked in the sunshine can be as high as 70°C or more. If flammable or explosive items such as lighters, cleaning agents and perfumes are stored in the vehicle, fire and even explosion can be easily caused.
 - After people leave the vehicle, items such as lithium batteries or power banks that are at risk of fire are also likely to cause fire.
2. Make sure the cigarette butts are completely extinguished after smoking:
 - If the cigarette butts are not completely extinguished, fire may be caused.
3. It is recommended to regularly drive to the GAC Motor authorized shop for inspection:
 - Regular inspections of all electric lines of the vehicle are also required. Check whether the connectors, insulation, and fixing positions of electrical units and wiring harnesses are normal. If problems are found, they shall be dealt with in a timely manner.
4. It is forbidden to modify the electrical circuits or add electrical units:
 - Adding electrical units (such as high-power audio device and xenon headlamps) will cause excessive load on the electrical line, and wiring harnesses can be heated and result in a fire.
 - It is strictly forbidden to use fuses that exceed the rated specifications of the electrical units or other metal wires to replace the fuses.
5. Precautions for driving:
 - During driving and parking period, especially in summer, pay attention to whether there are flammable items under the vehicle, such as hay, dry branches, leaves and wheat stalks. Since the temperature of components such as engine exhaust pipe increases after long time driving, if there are flammable items under the vehicle, they are likely to be ignited and cause a fire.
 - Do not park the vehicle in places where there is serious rat infestation, such as garbage dumps, and do not store items that attract rats, such as snacks, because rats will bite through the wire harnesses and may cause a fire.
6. Always place a lightweight fire extinguisher in the vehicle, and master the use method:
 - In order to ensure the safety of the vehicle, place a fire extinguisher in the vehicle, and regularly check and replace it; at the same time, be familiar with the use method of the fire extinguisher, so as to be prepared and avoid being helpless when accidents occur.

6.1 Maintenance instructions

Safety precautions

To avoid potential hazards, please read this section before work and confirm that you have the necessary tools and techniques.

- Make sure that the vehicle is parked on a level ground, shut down the engine and apply the parking brake.
- When cleaning parts and components, use the commercially available de-greaser or parts cleaner, instead of gasoline.
- Keep lit cigarettes, sparks, and open flames away from batteries and all fuel system related components.
- When working on batteries or with compressed air, wear goggles and protective clothing.

WARNING

Incorrect vehicle maintenance or driving the vehicle before the problem is solved may cause a traffic accident, resulting in serious injury or death.

Potential hazards of the vehicle

- Carbon monoxide: carbon monoxide in the exhaust gas of the engine is toxic. Be sure to operate the engine in a well-ventilated place.
- Burns: the engine and exhaust system are at high temperature during operation, which can easily cause burns. Therefore, wait till the engine has been shut down for 30 min and exhaust system cools down before touching the related parts and components.

CAUTION

This section lists some of important safety precautions. We cannot list all the dangers you may encounter during maintenance work.

6.2 Interior maintenance

Cleaning and maintenance of instruments and plastic parts

Clean the surface of instruments and plastic parts with a clean soft cloth and clean water.

If it cannot be cleaned, it is required to use a special solvent-free plastic cleaning agent for cleaning.

CAUTION

Solvent-based cleaning agents can damage plastic parts.

WARNING

It is forbidden to use cab sprays and solvent-based cleaning agents to clean the surface of the instrument panel and airbag assembly. Otherwise, it may loosen the surface and trigger the airbag, which may cause serious injury to occupants.

6. In-service maintenance

Cleaning and maintenance of carpet

Vacuum the dust on the carpet frequently.

Scrub the carpet regularly with detergent to keep it clean.

CAUTION

Please perform the cleaning in strict accordance with the use instructions of cleaning agents.

WARNING

It is forbidden to add water to the foam cleaner. The carpet shall be kept as dry as possible.

Cleaning and maintenance of leather*

- Vacuum the dust.
- Clean the leather with a clean soft cloth and clean water.
- Wipe the leather dry with another dry soft cloth.
- If the cleaning methods described above are not enough to clean stains, please combine these methods with special leather cleaning soap or detergent.

CAUTION

If a leather stain remover is used, wipe it dry with a soft dry cloth as soon as possible.

WARNING

Never leave a soft cloth wet with leather stain remover on any part of the interiors for a long time. Avoid discoloring or breaking the resin or fibers of interior fabrics.

Cleaning and maintenance of seat belts

- Pull the seat belt out slowly and keep it being extracted.
- Remove dirt from the seat belt by using a soft brush and neutral soapy water.
- After seat belts dry completely, retract the seat belts.

CAUTION

- Wait till the seat belts dry completely before retracting them. Otherwise, seat belt retractors may be damaged.
- Regularly check all the seat belts in the vehicle to ensure that the seat belts are clean and avoid hindering the normal operation of seat belts.

WARNING

- If the seat belt webbing, connectors, retractor mechanism or buckles are damaged, please go to the GAC Motor authorized shop for replacement as soon as possible.
- For the overhaul of an accident vehicle, seat belts must be replaced, no matter whether they are damaged.
- If snow tires are installed, the size, brand, structure and tread pattern of the snow tires used on the four wheels shall always be the same.
- Avoid foreign objects or liquids entering the seat belt buckles, which may result in the buckles and seat belts not working properly.
- Under any circumstances, it is forbidden to remove or modify seat belts without authorization.
- It is forbidden to use chemical cleaning agents to clean the seat belts, for fear of damaging the seat belt base and impairing the function of seat belt.

Cleaning and replacement of filters

The vehicle is equipped with an air filter, an A/C filter, an oil filter, a fuel filter, etc. They aim to filter gas or fluids. If they are too dirty or clogged, the normal operation of corresponding systems will be affected. Therefore, it is recommended to regularly clean or replace the filters at the GAC Motor authorized shop according to the provisions of the *Warranty Manual*.

6.3 Exterior maintenance

Vehicle washing

Washing the vehicle frequently helps to protect its appearance.

Vehicle washing shall be performed in a cool place, rather than under direct sunlight. If the vehicle is left in the sun for a long time, wait till the vehicle body surface cools down before washing the vehicle.

When using an automatic vehicle washer, be sure to follow the instructions of the operator of the automatic vehicle washer.

WARNING

The ignition switch must be set to OFF before vehicle washing.

6. In-service maintenance

CAUTION

The strength of the paint surface of the vehicle body is sufficient to withstand the washing of the automatic vehicle washer. However, the effects on the paint surface must be paid attention to. The structure of the automatic vehicle washer, the cleaning agent, the filtering state of the clean water, and the type of wax solvent that do not meet the requirements may cause damage to the paint surface.

Manual vehicle washing

- Rinse the vehicle with plenty of water to remove floating dust.
- Prepare a bucket of water and add a special cleaning agent for vehicle washing to it.
- Gently scrub the vehicle with a soft cloth, sponge or soft brush and rinse it several times from top to bottom.
- Rinse the parts such as wheels and door sills at last. Replace sponges or soft cloth when washing the vehicle.
- After scrubbing, rinse the vehicle thoroughly with plenty of water.
- After washing, carefully dry the paint surface of the vehicle using a soft towel or antelope skin.

CAUTION

When the vehicle body has dirt such as asphalt, it needs to be cleaned with a special cleaning agent, and then rinsed with clean water to avoid damaging the surface finish of the vehicle body. Check the body for paint peeling and scratches while wiping the body. If any, drive to the GAC Motor authorized shop for touch-up.

When using a steam cleaner or a high-pressure cleaner to wash the vehicle, be sure to be very careful. Be sure to wash the vehicle in accordance with the operation instructions and requirements of the steam cleaner or high-pressure cleaner. Pay attention to the working pressure, temperature and spraying distance:

- When using a steam cleaner or a high-pressure cleaner to wash the vehicle, keep a sufficient water spray distance from the vehicle, and ensure the temperature does not exceed 60°C.

- If the vehicle is equipped with an electric sunroof, keep the water spray distance more than 80 cm when washing the vehicle. If the high-pressure cleaner is close to the vehicle, or if excessive pressure or temperature is used, the vehicle may be damaged.
- Do not wash a radar sensor or a parking assist camera with a high-pressure cleaner for a long time; when washing the radar sensor or parking assist cameras, keep the water spray distance more than 30 cm.

WARNING

- **When washing the vehicle manually, pay attention to personal safety and beware of angular parts at the bottom of the vehicle to avoid being scratched.**
- **When washing the vehicle, pay special attention to the bottom of the vehicle and the inner side of wheelhouses. Do not hurt hands and arms with sharp parts.**
- **Never spray water directly into the engine compartment when washing the vehicle. Otherwise, it will affect the service life of various parts and components in the engine compartment.**

Waxing

Regular waxing can protect the paint surface of the vehicle body and keep the vehicle body clean. In order to effectively protect the paint surface of the vehicle body, it is recommended to apply high-quality hard wax once a year to protect the paint surface against corrosion by external bad environments and to resist light mechanical scratch.

Be sure to wipe the appearance of the entire vehicle dry before waxing. When waxing the vehicle, please select a high-quality wax protectant. High-quality wax protectant generally falls into the following two types of products:

- Vehicle body wax: a wax used to protect the paint surface against damage by external bad environments such as sun exposure and air pollution.
- Polishing wax: a wax which can restore the gloss of the paint surface that has been oxidized or tarnished. This type of wax is generally used to restore the gloss of paint surface.

Cleaning and maintenance of external plastic parts

External plastic parts are generally washed with clean water, soft cloth and soft brushes. If they cannot be cleaned, please use the special solvent-free plastics cleaner approved by our company.

CAUTION

Do not use solvent-based cleaning agents when washing plastic parts. Otherwise, it is easy to damage the plastic parts.

Washing of window glasses and rearview mirrors

Clean the window glasses and rearview mirrors with alcohol-based glass cleaner, and then wipe the glass surface dry with a clean, lint-free soft cloth or antelope skin.

After curing the surface of the vehicle body, remove the wax residue on the glasses with a special cleaning agent and cleaning cloth. Avoid scratching the wiper blades.

Remove snow from the windows and rearview mirrors using a small brush.

Remove accumulated ice using de-icer spray. An ice shovel can also be used, but special care must be taken to avoid damage to the components, and ice must be shaved in the same direction.

6. In-service maintenance

CAUTION

- It is forbidden to scrape the surface back and forth.
- It is forbidden to remove ice and snow from the windshields and rearview mirrors using warm water or hot water. Otherwise, the windshields may burst.
- If there are residual objects such as rubber, grease and silicone on the glass, they must be removed with a special window cleaner or silicone cleaner.

Cleaning of wiper blades

- Raise the wiper arm and carefully wipe off the dust and dirt on the wiper blade with a soft cloth.
- After cleaning, gently lower the wiper arm back to the windshield.

CAUTION

- While lifting a wiper arm, please grasp the hard bracket with hands, rather than grasp the soft wiper blade.
- The wiper blades are coated with a layer of graphite which makes the wiping operation smooth and does not produce scraping noise. Solvent-based cleaning agents, hard sponges and sharp objects can damage the graphite layer. Damaged graphite layer will increase the wiping noise of the wiper, and the wiper shall be replaced in time.
- In winter or cold conditions, be sure to check whether the wiper blade is frozen together with the windshield before using the wiper. If so, perform de-icing first. Otherwise, the wiper blade and wiper motor will be damaged.

Maintenance of sealing strips

Frequent and proper protection of the rubber sealing strips of the doors, windows and other parts of the vehicle is intended to maintain their flexibility and prolong their service life. Such protection can also improve the tightness, make the door easy to open, reduce the impact sound of closing the door, and prevent freezing in winter.

When performing maintenance on sealing strips, remove dust and dirt from surfaces using a soft cloth. Apply special protective agent to rubber sealing strips regularly.

Cleaning and maintenance of wheels

Regularly remove anti-skid salts on the wheels and debris on the brake linings, keep the wheels aesthetic, maintain the surface smooth and prolong the service life of wheels. It is recommended to perform the following operations regularly:

- Remove anti-skid salts on the wheels and debris on the brake linings using acid-free detergent every two weeks.
- Apply high-quality hard wax to the alloy wheels every three months.

CAUTION

- It is prohibited to maintain the wheel surface with vehicle polish or other abrasives.
- The wheels with damaged protective coating on surface must be repaired in time.
- Using a high-pressure cleaner may cause permanent visible or invisible damage to the wheels, resulting in serious injury or death.
- It is forbidden to use cluster head nozzles to spray the tires. Otherwise the tires will be damaged, causing traffic accidents.

6.4 Checking and adding fluids

6.4.1 Fuel

As the amount of fuel decreases when the vehicle is running, the fuel meter scale will gradually decrease.=> [See page 39](#)

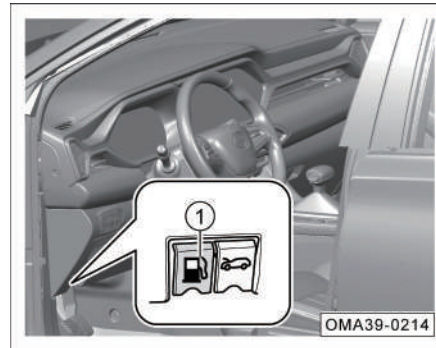

When the fuel level is too low,  the yellow indicator lamp flashes, and the instrument cluster will give an alarm message. At this time, fuel shall be added as soon as possible.

Adding fuel

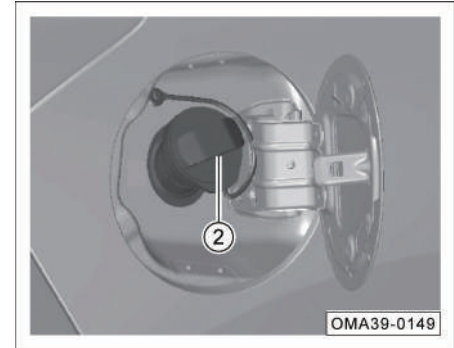

- Pull up the fuel tank cap opening handle  to make the fuel tank cap pop up.



- Open the fuel tank cap completely, and slowly unscrew the filler cap  counterclockwise. Keep the filler cap  at the original place for a while when it is unscrewed completely to allow fuel tank to release the fuel vapor inside, and then remove it.

6. In-service maintenance

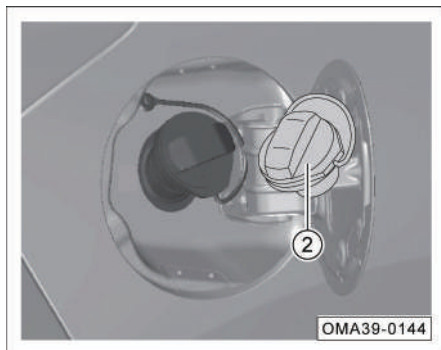

- Suspend the filler flap ② on the inner side of the fuel tank cap and start adding fuel.
- After adding the fuel, tighten the filler flap ② clockwise till the “click” sound is heard for three times, which indicates that the flap has been tightened.

i NOTE

Fuel grade: 92# or above high-quality lead-free gasoline

i NOTE

This model complies with China VI emission standards. The fuel supply system of China VI is designed with a closed fuel and gas recovery system. During refueling, the fuel gun switch may be triggered due to high ambient temperature or high fuel flow rate, and the fuel gun is switched off when the fuel tank is not filled fully. This is a normal phenomenon. At this time, the refueling speed shall be slowed down.

👁 CAUTION

Low-grade fuel or substandard fuel may damage the engine or make the engine fail to meet performance requirements.

⚠ WARNING

- **At any time, be sure to shut down the engine when refueling, and note that there should be no open flame or fire in the surroundings.**
- **Please avoid contact of fuel with skin or clothing.**
- **Please refuel the vehicle according to the vehicle fuel grade. If fuel not complying with the regulations is added accidentally, do not start the engine. Please contact the GAC Motor authorized shop immediately for treatment.**

6.4.2 Engine oil

Function of engine oil

Engine oil has functions such as lubrication, sealing, cooling, anti-rusting and cleaning.

Specifications of engine oil

The engine has been filled with high-quality engine oil, which can be used in the year-round climate except for extreme cold weather before delivery.

When purchasing engine oil, please check whether the specifications indicated on the outer packaging of the engine oil are suitable for the engine of this vehicle.

i NOTE

- Engine oil grade: SN or above.
- Engine oil viscosity: SAE5W-30.

⚠ WARNING

Always use the engine oil approved by our company. Otherwise, the ensuing engine damage will not be covered by the warranty.

i NOTE

- Be sure to go to the GAC Motor authorized shop to change the engine oil according to the period specified in the *Warranty Manual*.
- If the vehicle is running under severe conditions, fuel with high sulfur content is used, engine idles for a long time (e.g., a taxi), the vehicle is driven in a high-dust area, the vehicle often tows a trailer, or the vehicle is used in an alpine area, the maintenance periods shall be shortened and the maintenance times shall be increased.

Low oil pressure warning lamp

When driving, if the warning lamp  comes on, be sure to stop the vehicle in a safe place and shut down the engine. After the engine cools down, check the oil level.

If the engine oil level is normal, but the warning lamp is still on after the engine is started, do not continue to start the engine. In this case, contact the GAC Motor authorized shop timely for inspection.

⚠ WARNING

- **Ignoring the warning lamps and related warning instructions may damage the engine.**
- **The low oil pressure warning lamp can not indicate the oil level, and the oil level must be checked regularly.**

6. In-service maintenance

Checking the oil level

Be sure to check the oil level regularly. Park the vehicle on level ground, apply the park brake, and shut down the engine. After the engine cools down, open the engine hood and check the oil level.

WARNING

- Be extremely careful when working in the engine compartment.
- The engine compartment is a high-risk area. Be sure to read and follow the relevant warning instructions carefully before opening the engine hood.

NOTE

While checking the oil level, ensure the engine is cold.

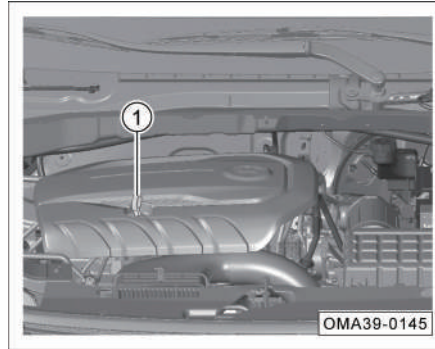

- Pull out the dipstick ①.

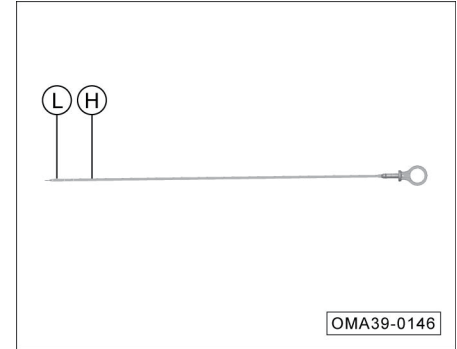

- Wipe off the oil stains on the dipstick using a clean cloth, and then insert the dipstick completely.
- Pull out the dipstick again and read the measured oil level, which shall be between "L" (lower limit mark) and "H" (upper limit mark).
- If there is too little engine oil, please add engine oil in time. Otherwise, poor lubrication will damage the engine.

Adding engine oil

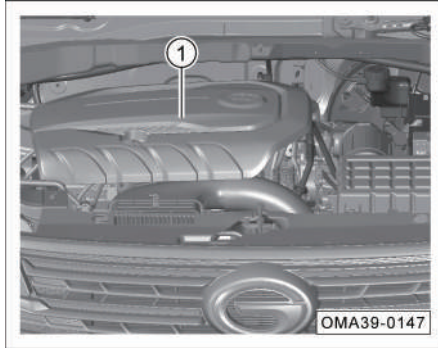

After checking the oil level, if required, add engine oil following the steps below:

- Lift up and remove the engine upper guard plate ①.

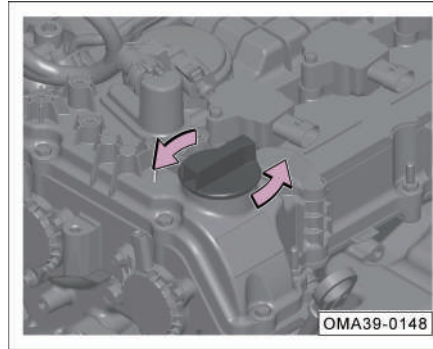

- Unscrew the oil filler cap counterclockwise.
- Add the engine oil in small quantities several times, and check the oil level after each filling.
- When the oil level is close to the upper limit mark (H), indicating the engine oil is sufficient, stop adding oil, refit the oil filler cap and tighten it clockwise.

WARNING

- Be careful when adding the engine oil. Do not spill it. If the engine oil gets on skin, be sure to rinse the skin thoroughly.
- If too much oil is added, do not start the engine. In this case, please contact the GAC Motor authorized shop as soon as possible. Otherwise, the three-way catalytic converter may be damaged.
- After filling, be sure to tighten the oil filler cap to prevent the engine oil from splashing when the engine is being started, for fear of a fire.
- Since Engine oil is toxic, it shall be stored in the original container and kept out of children's contact to avoid poisoning due to accidental ingestion.
- Do not add any lubricants to the engine oil. Otherwise, the engine may be damaged. Engine failure caused by adding lubricants is not covered by the warranty.

6. In-service maintenance

6.4.3 Coolant

Function of coolant

Coolant has functions such as cooling, anti-freezing and anti-corrosion.

Specifications of coolant

The cooling system has been filled with coolant before delivery. This coolant can be used in the year-round climate except for extreme cold weather. It can also prevent corrosion of cooling system alloy components and system scale incrustation.

i NOTE

- Specifications of coolant: DF-6, -35 °C.
- Be sure to go to the GAC Motor authorized shop to change the coolant according to the period specified in the *Warranty Manual*.
- If the coolant is discolored, the maintenance period shall be shortened and the coolant shall be changed at a GAC Motor authorized shop.

High engine coolant temperature indicator lamp

When driving, always observe the indication of the engine coolant temperature gauge to know the coolant temperature.

If the coolant temperature is too high, the indicator lamp  on the instrument cluster comes on in red, and an alarm message is given to prompt the driver; at this time, the vehicle must be stopped in a safe place and the engine turned off. After the engine cools down, check the coolant level.

If the coolant level is normal but the indicator lamp is still on after the engine is started, do not continue to start the engine. In this case, contact the GAC Motor authorized shop timely for inspection.

Checking the coolant level

Be sure to check the coolant level regularly. Park the vehicle on level ground, apply the park brake, and shut down the engine. After the engine cools down, open the engine hood and then check the coolant level.



WARNING

- **Be extremely careful when working in the engine compartment.**
- **The engine compartment is a high-risk area. Be sure to read and follow the relevant warning instructions carefully before opening the engine hood.**
- **If steam or coolant flows out from the engine compartment, do not open the engine hood, for fear of burns; wait till there is no steam or coolant overflowing and the engine cools down before opening the engine hood.**

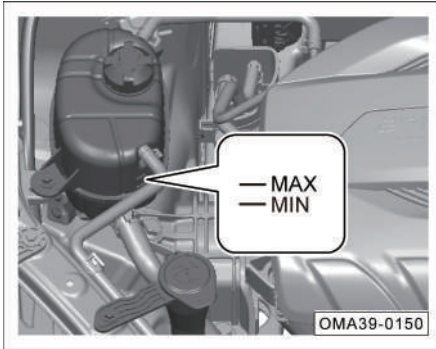

Check whether the coolant level in the expansion tank is between the maximum scale mark "MAX" and the minimum scale mark "MIN".

i NOTE

When the engine is not cooled, the coolant level will be high, and there will be errors in checking the coolant level.

👁 CAUTION

When the coolant level is lower than the minimum scale mark "MIN", coolant must be added. Insufficient coolant will affect the cooling effect and cause engine damage.

Adding coolant

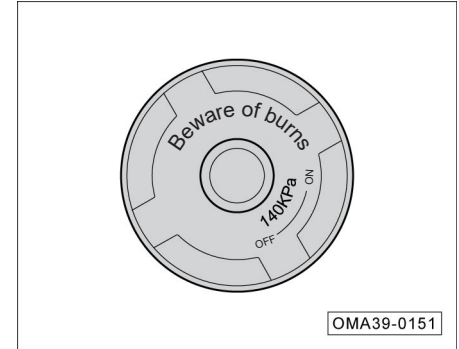

After checking the coolant level, if required, add coolant following the steps below:

- Wrap the expansion tank cap with a thick cloth and unscrew it counterclockwise.
- Add coolant between the upper limit mark "MAX" and the lower limit mark "MIN".
- Tighten the expansion tank cap clockwise.

6. In-service maintenance

CAUTION

- When the engine is not cooled, the cooling system is under high pressure. In this case, do not open the expansion tank cap, otherwise the emerging coolant will cause scald.
- The expansion tank cap must be wrapped with a thick cloth before being screwed off to prevent burns.
- Coolant can only be added after the engine has cooled down. The coolant level after filling must not exceed the upper limit mark "MAX". Otherwise, when the engine is started and the cooling system is under high pressure, coolant will overflow.
- Only add fresh coolant.

WARNING

- **It is forbidden to mix coolant that is not approved by our company into the original coolant; otherwise, the engine may be damaged due to incompatibility.**
- **In case of emergency, if other coolant is used or pure water is added, go to the GAC Motor authorized shop to clean the cooling system and change the coolant in time.**
- **If the too much coolant is consumed or it is consumed too fast, there may be a leak in the cooling system. In this case, please go to the GAC Motor authorized shop for inspection in time.**
- **Coolant must be stored in accordance with environmental protection laws.**
- **Coolant must be contained in the original container, and kept out of children's contact to avoid poisoning due to accidental ingestion.**

6.4.4 Windshield washer fluid and wiper blades

Adding windshield washer fluid

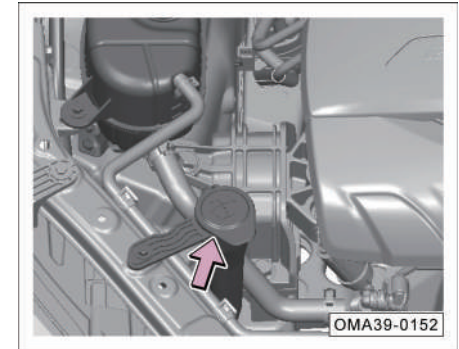

If the level of the washer fluid is too low, the washer fluid shall be added in time.

CAUTION

Do not mix and use the windshield washer fluid with other cleaning liquids. Otherwise, the washer fluid will be decomposed and block the nozzle of the windshield washer.

WARNING

- Be extremely careful when working in the engine compartment. Be sure to read and follow the relevant warning instructions carefully before starting work.
- Do not misuse coolant or any other additives as windshield washer fluid. Otherwise, oil stains will be left on the windshield during cleaning of the windshield, which will affect the visibility and easily cause accidents.
- It is forbidden to use windshield washer fluid with more than 10% ethanol content. In high temperature environment, this type of windshield washer fluid will cause corrosion and even crack of tail lamps. It is recommended to use methanol washer fluid.

Replacing front windshield wiper blades



- Switch the ignition switch to the "ON" position and then to the "OFF" position.
- Move the wiper combination switch to the "MIST" position within 10 s. The wiper arm will stop after running for half a circle.

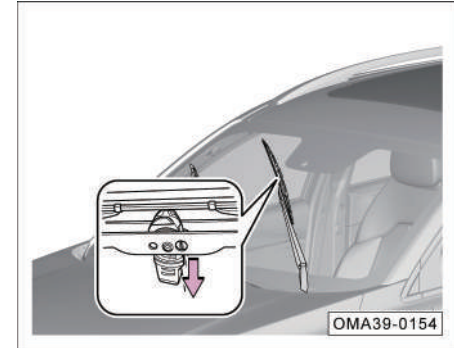

- Lift the wiper arm, turn and press the wiper blade (as shown) downwards to remove it.
- Install the new wiper blade into the wiper arm in reverse steps. It is installed in place when a "click" is heard.
- Gently put the wiper arm back into the windshield.

6. In-service maintenance

Replacing rear windshield wiper blades

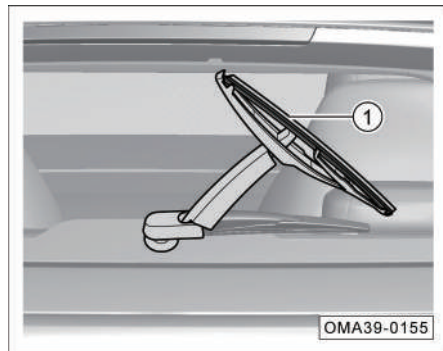

- Lift the wiper arm.
- Pull the wiper blade ① to remove it.
- Install a new wiper blade to the wiper arm.
- Gently put the wiper arm back into the windshield.

If replacing wiper blades is required, it is recommended to go to the GAC Motor authorized shop for replacement.

CAUTION

- When lifting the wiper arm, please grasp the wiper arm with hands, rather than grasp the soft wiper blade.
- New wiper blades with the same length and specifications as the previous ones must be used.
- Be careful when lowering the wiper arm to prevent it from falling and hitting the windshield instantly.
- The status of the wiper blades must be checked regularly, and the wiper blades must be replaced as specified. Damaged wiper blades must be replaced in time.
- Excessively worn or dirty wiper blades are very easy to scratch the windshield, and will affect the field of vision when used, reducing driving safety.

6.4.5 Brake fluid

Function of brake fluid

Brake fluid is used to transmit power in the hydraulic brake system of the vehicle.

The brake fluid used in this vehicle is specially developed by our company for the brake system of this vehicle. To ensure the normal operation of the brake system, only the brake fluid recommended by the original manufacturer is allowed.

The brake fluid is water-absorbent, so it can continuously absorb moisture in the surrounding air during use. If the brake fluid stays in the system for too long and absorbs too much moisture, air resistance will generate in the system pipeline during braking, reducing the braking effect and impairing driving safety; it may even cause the complete failure of the brake system, resulting in accidents. Therefore, be sure to go to the GAC Motor authorized shop to check the brake fluid level or change the brake fluid according to the period specified in the Warranty Manual.

NOTE

Specifications of brake fluid: DOT4.

WARNING

- Using waste brake fluid or using brake fluid not applicable to the vehicle will remarkably reduce the braking effect and even cause the brake system to fail! The company does not assume any responsibility (including quality guarantee) for vehicle failures and damage caused thereby.
- Brake fluid in use must meet the criteria, and be fresh.
- Brake fluid containers are marked with brake fluid specifications. In any case, use the correct brake fluid.

Brake system indicator lamp

If the indicator lamp  comes on in red, and the instrument cluster displays the information "Please add brake fluid" during vehicle running, be sure to immediately stop the vehicle at a safe place and check whether the brake fluid level is normal.

Checking brake fluid level

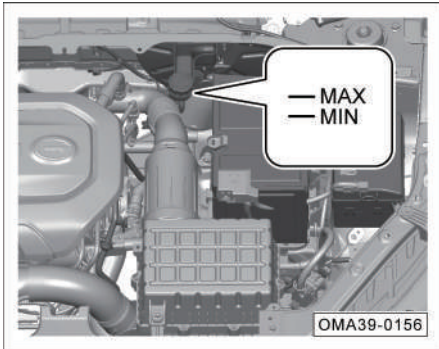

When the engine has been cooled down, check whether the brake fluid level is between the maximum scale mark "MAX" and the minimum scale mark "MIN".

During vehicle use, the brake fluid level will slightly drop due to the worn brake linings and automatic adjustment.

If the brake fluid level drops significantly in a short period of time or drops below "MIN", it indicates that the brake system may leak.

NOTE

- Be sure to read and follow the relevant warning instructions carefully before opening the engine hood.
- After check of the brake fluid level, if the fluid level is below "MIN", brake fluid must be added.
- If the brake system indicator lamp does not go out or comes on again after the brake fluid is added, there may be a leak in the brake system, causing the brake fluid level to drop quickly, or the brake system malfunctions. In this case, do not continue to drive and contact the GAC Motor authorized shop in time for inspection.

6. In-service maintenance

Adding brake fluid

In order to ensure the normal operation of the brake system, the added brake fluid shall meet the specifications:

- Open the brake fluid reservoir cap counterclockwise.
- Add fresh brake fluid to the maximum scale mark "MAX" and stop adding.
- Tighten the brake fluid reservoir cap clockwise.

CAUTION





- **The brake fluid will corrode the paint surface of the vehicle body. Brake fluid splashed on the paint surface shall be wiped off in time.**
- **Using waste brake fluid or using brake fluid not applicable to the vehicle will remarkably reduce the braking effect due to incompatibility and even cause the brake system to fail.**

WARNING

- **Since brake fluid is toxic, it must be contained in the original sealed container, placed in a safe place, and kept out of children's contact to avoid poisoning due to accidental ingestion.**
- **Brake fluid must be stored in accordance with environmental protection laws.**

6.4.6 Battery

Warning symbols and instructions for battery operation

	Goggles must be worn during operation!
	The battery electrolyte is highly corrosive. Protective gloves and goggles must be worn during operation!
	Open flames, sparks, naked lamps and smoking are prohibited in the workplace!
	Very explosive gas mixture is generated when the battery is being charged!
	Children must stay away from electrolytes and vehicle batteries!

If not familiar with the operation process or without special tools, never carry out any operations on the electrical system of the vehicle. The relevant operations shall be carried out by the GAC Motor authorized shop.

WARNING

- **Before operation, be sure to carefully read and follow the warning instructions for safety related to battery operation.**
- **Only the personnel with the necessary professional knowledge can work on the battery.**
- **Never disassemble the battery, and beware of chemical burns or battery explosion.**
- **Do not use damaged or leaking batteries. Damaged or leaking batteries must be recycled and disposed of in accordance with environmental protection regulations.**
- **Open flames, sparks, naked lamps and smoking are prohibited in the workplace! When operating cables and electrical consumer, care must be taken to prevent electric sparks and static electricity. Do not short-circuit the battery terminal, otherwise the high-energy electric sparks generated due to the short circuit may injure the operator.**

Charging system warning lamp

The warning lamp is used to indicate alternator failure.

When the ENGINE START/STOP button is turned to the "ON" position and the engine is not started,  the warning lamp comes on. After the engine is started, the warning lamp shall go out.

If the warning lamp comes on during vehicle running, it indicates that the alternator is no longer charging the battery. In this case, please go to the GAC Motor authorized shop for inspection as soon as possible.

Checking the battery

The battery must be checked according to the period specified in the Warranty Manual.

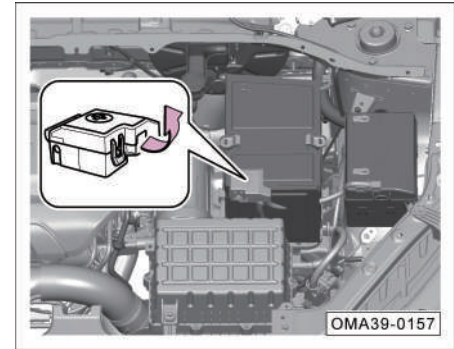

- Flip up the cover of the battery positive terminal.
- Check the connection of the battery connector and the cable for corrosion or looseness; check the appearance of the battery for cracks, swelling, etc. If the phenomena above are found, please go to the GAC Motor authorized shop for inspection as soon as possible.
- If the vehicle is inoperative for a long period of time, check the battery condition frequently.

6. In-service maintenance

NOTE

- If the battery is low in power or damaged, making the engine difficult to start, please contact the GAC Motor authorized shop to charge or replace the battery.
- If it is required to replace the battery, please go to the GAC Motor authorized shop for replacement; if a wrong type of battery is used, the vehicle may not run due to incompatibility or the electrical system may fail.

Instructions for using the battery

After the engine is turned off, the battery will quickly discharge when electrical consumers on the vehicle are being used:

1. Do not use electrical consumers on the vehicle for a long time after the engine is turned off.
2. When leaving the vehicle, make sure that the doors are closed and all electrical consumers (e.g., lamps) are turned off.

CAUTION

- If the engine cannot be started due to depleted battery, please try emergency start. If the engine still cannot be started, please contact the GAC Motor authorized shop for overhaul.
- To avoid damage to the electrical system of the vehicle, never connect power generation equipment such as solar panels or vehicle battery chargers to a power outlet.
- The battery contains toxic substances such as sulfuric acid and lead, so it must be disposed of properly and must not be treated as ordinary household waste.

6.5 A/C filter

Checking and cleaning the A/C filter

Check or clean the A/C filter regularly according to the provisions in the *Warranty Manual*. If the vehicle is running in a dusty environment and the A/C filter is too dirty, it is recommended to replace the A/C filter earlier.

NOTE

If it is impossible to remove and refit the A/C filter by yourself, please go to GAC Motor authorized shop to seek professional help.

Removing and refitting the A/C filter

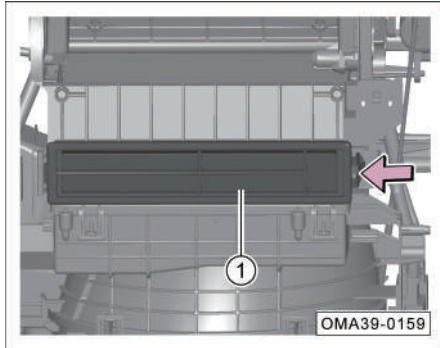

1. Open the glove box cap.
2. Press the sides of the glove box in the direction of arrow A.
3. Disconnect the glove box in the direction of arrow B.

i NOTE

After the glove box is disconnected, lower the glove box to the lowest position.

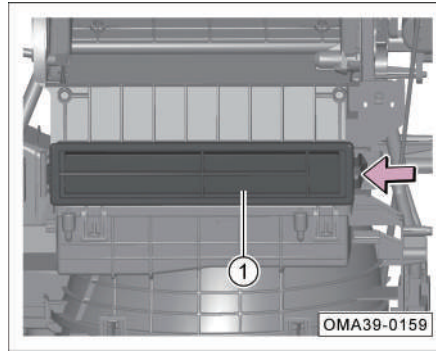

4. Press the fixing clip of the A/C filter cover and take out the A/C filter cover ①.

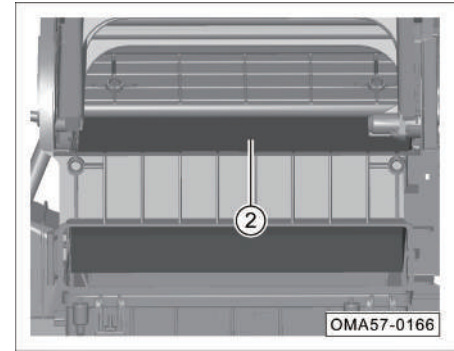

5. Take out the A/C filter ②.
6. Tap the A/C filter element to remove the dust.

6. In-service maintenance

CAUTION

- Because the fiber layer on the back of the A/C filter can not be blown with an air gun, it can not be cleaned and needs to be replaced in time after getting dirty.
- Since the A/C filter is made of special material, it shall neither contact water nor be washed with water. Otherwise, dust will accumulate and form clots, which will cause decreased air volume of A/C or even blockage.

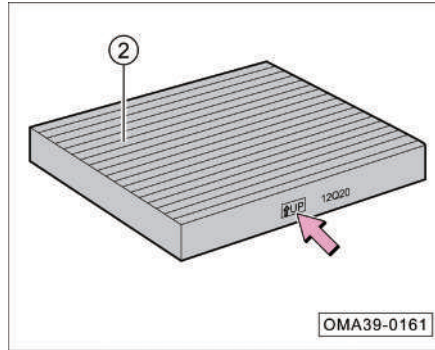

When installing the A/C filter ②, install it according to the upward mark of the A/C filter ②.

6.6 Replacing bulb

Instructions for replacing bulbs

When replacing bulbs, be careful not to touch the bulb glass with fingers. Otherwise, the heat of the bulb will evaporate the grease on the bulb from fingerprints and condense it on the bulb reflector, reducing the illuminance of the lamp.

After replacing bulbs, be sure to check the working status of lamps, and go to the GAC Motor authorized shop to check the beam status in time.

NOTE

- Lamps for the vehicle include halogen and LED types. If the LED bulb is damaged, please go to the GAC Motor authorized shop for replacement.
- The removal and refitting methods of the left and right bulbs are basically the same. Here only the removal and refitting methods of halogen bulbs on one side are described.

CAUTION

Damaged bulbs must be replaced with new ones with the same specifications; for the specific specifications => [See page 246](#).

WARNING

If unfamiliar with the operation process, safe operation specifications and tool operation methods, do not replace bulbs yourself.

- Turn off all lamps before replacing bulbs, and wait for bulbs till they are cool before replacement.
- Pay attention to the sharp parts on the combination lamp housing in the engine compartment during operation, and be careful not to scratch hands when replacing bulbs.

Steps for replacing bulb

If it is found that any bulb is damaged, it shall be replaced as soon as possible. Before replacement, make the following preparations:

1. Turn off all lamps.
2. Turn the ENGINE START/STOP button to the "OFF" position.
3. Check whether the related fuse is blown. When the fuse is in good conditions, perform bulb inspection and replacement.

Replacing low beam bulb

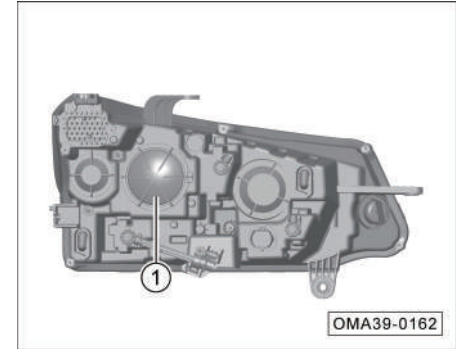

1. Screw out the low beam sealing cover ① counterclockwise.

6. In-service maintenance

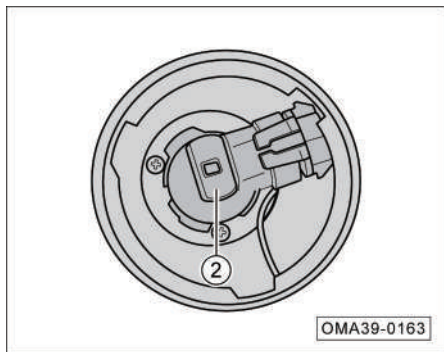

2. Screw out the high beam bulb ② counterclockwise.

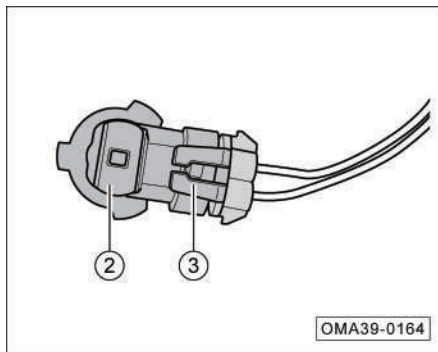

3. Use a slotted screwdriver to slightly pry the connector clip ③, and pull out the low beam bulb ②.
4. Install the new low beam bulb in the reverse order.

Replacing high beam bulb

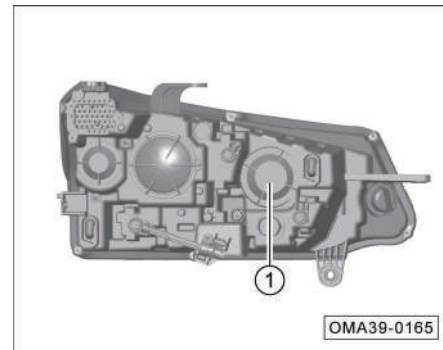

1. Screw out the high beam sealing cover ① counterclockwise.

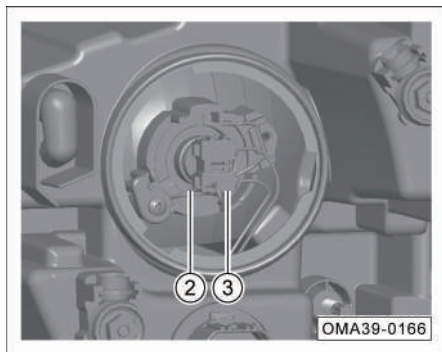

2. Press the fixing wire ② and take it out of the fixing slot.
3. Take out the high beam lamp holder and bulb ③.

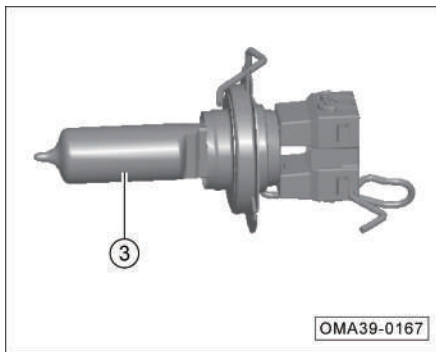

4. Remove the and bulb ③ from the high beam lamp holder.
5. Install the new high beam bulb in the reverse order.

6.7 Wheels

WARNING

Within the first 500 km, the road adhesion of new tires is unlikely to reach the best condition. Therefore, the vehicle shall be drove carefully at a moderate speed to prevent accidents.

- Inadequate road adhesion of tires not subject to running-in period or excessively worn can directly affect the braking effect.
- If it is found that the vehicle is abnormally vibrating or deviating, stop the vehicle immediately and check whether the tires are damaged.
- If it is found that the tires are unevenly and excessively worn, please go to the GAC Motor authorized shop for inspection as soon as possible.

6. In-service maintenance



WARNING

If tires burst or leak when the vehicle is running, it is very easy to cause serious traffic accidents.

- Never use damaged tires and wheels, or use tires of which the treads have been worn to the wear indicators. Otherwise, it is very easy to cause an accident, because such tires may burst during driving, causing traffic accidents and injury. Such tires and wheels shall be replaced in time.
- The tire pressure must be up to specification. Otherwise, it may cause an accident. If the tire pressure is insufficient, the continuous high-speed running of the vehicle will cause the tire to deflect, and the tire is extremely easy to be overheated, which may cause tread separation or tire burst.
- Be careful not to expose the tires to chemicals, oil, grease, fuel and brake fluid.



WARNING

- Never install any used wheels and tires of unknown origin under any circumstances. Although such wheels and tires do not have visible damage, they may have been damaged. During driving, they may cause the vehicle to lose control and lead to traffic accidents.
- It is not recommended to use recycled tires. For such tires, the carcass may degrade as the service time passes, and the durability may also be restrained, impairing the driving safety.

Precautions for wheel failure

- When driving over curbs or similar obstacles, keep a slow speed in the vertical direction of the obstacles as much as possible.
- Be careful not to let the tires contact with grease, oil and fuel.
- Regularly check the damage status of tires (i.e., splitting, abrasion, shedding, deformation or bulging).
- Regularly remove debris embedded in the grooves of the tire pattern.

Instructions for storing tires

- Before removing the tire, make a mark on the tire to indicate the rotation direction of the tire. Refit the tire according to the mark to ensure the rotation direction and the dynamic balance of the wheel are unchanged.
- Store the removed wheels or tires in a cool, dry place, and preferably in a dark place.
- The tire mounted on the rim must not be stored upright.

New tires and wheels

- Select the new tire and wheel carefully, and make sure that the dimensions, load range, rated speed and structure type of new tire are the same as those of original one.
- Replace at least two tires on the same axle at the same time, rather than only one tire individually.
- Do not use tires of different dimensions or types, and do not mix summer tires, all season tires and winter tires in use.
- It is recommended to install and use tires and wheel combinations approved by the company for the relevant models. For unapproved wheels and tires, the company cannot judge and cannot guarantee the safety of the vehicle during running.
- Once wheels are installed, check whether the tightening torque of the wheel bolts ($125 \pm 10N \cdot m$) meets the requirements.

Non-full-size spare tires

Spare tires and standard tires are different in aspects such as structure, pattern, speed grade and load index, and can not be exchanged.

After emergency use of the spare tire, it is necessary to drive safely to the GAC Motor authorized shop or the wheel repair shop as soon as possible to replace it with a standard tire, so as to avoid the hidden safety hazards of long-term use of the spare tire.

WARNING

- **Spare tires can only be used temporarily for emergency, and the maximum driving speed shall not exceed 80 km/h.**
- **The storage and service life of spare tires is 6 years. It is prohibited to use them beyond the time limit.**
- **The non-full-size spare tires are not allowed to be installed on the front drive wheels.**

Summer tires

Summer is a rainy season. The tire tread depth directly affects the driving safety in rainy days. In summer, when the tire tread depth is less than 3 mm, there is a high risk of water slippage.

Winter tires

Winter tires still have good grip performance when roads are covered with snow and ice. The specially designed rubber tread makes the tires less affected by low temperature environment and excellent braking ability, ensuring driving safety.

- Use winter tires for all the four wheels.
- It is recommended to use winter tires when driving in icy or snowy days in winter or when the temperature is below 7°C.
- Use only radial winter tires of same dimensions, load range and rated speed as original ones and approved for this vehicle.

6. In-service maintenance

- Please note that the tread of winter tires shall have patterns deep enough (tread depth not less than 4 mm; otherwise, the applicability in winter will be limited). After installation of tires, check the tire inflation pressure.

⚠ WARNING

- **Winter and summer tires are designed according to their respective typical lane conditions under the corresponding seasonal conditions. It is recommended to use winter tires in winter. At low temperatures, the adaptability of summer tires is significantly poorer, thereby losing road adhesion and braking ability.**
- **In severe cold conditions, if summer tires are used, cracks may appear on the tires, thereby completely damaging the tires, and causing excessive tire noise and loss of balance.**

⚠ WARNING

- **Winter tires may lead to decreased traction force of the vehicle on dry roads, increased road noise and shortened service life of tread. Please pay attention to the performance change of the vehicle in terms of maneuvering and braking after the winter tires are used.**
- **Please note that the maximum speed for winter tires is relatively low. Do not exceed the allowable maximum speed for the tires.**
- **Please note that when driving in atmospheric temperature rising above 7°C, in order to ensure driving safety and performance, please replace the winter tires with summer tires in time.**
- **When driving with winter tires, if a spare tire is installed, unstable steering characteristics may occur due to different tires, weakening driving stability. In this case, driving styles need to be adjusted and driving shall be performed carefully.**

Checking tire pressure

Tyre Pressure ضغط الإطارات		
MODEL الموديل	FRONT الإطار الأمامي	REAR الإطار الخلفي
225/60R17 99H/V	230kPa	230kPa
225/55R18 98V	(2.3kgf/cm ²)	(2.3kgf/cm ²)
T155/90D16 110M	420kPa (4.2kgf/cm ²)	
T135/90R17 104M		

OMA39-0254

The standard tire pressure data label of the original tire of this vehicle is attached to the B pillar on the driver's side.

- Check the tire pressure value applicable to the vehicle from the data label (the listed pressure values apply to both summer and winter tires).
- Unscrew the valve cap (if the valve cap is missing, a new one shall be provided in time).
- A high-quality tire pressure gauge is required to check the tire pressure. It is impossible to determine whether the tire pressure is appropriate only by visual inspection.
- Attach the tire pressure gauge to the valve.

6. In-service maintenance

- For inspection of tire pressure, the tire must be in a cold state. When the temperature increases, the tire pressure can be slightly higher than the specified value, and it is not necessary to reduce the tire pressure.
- Balance the weight of occupants and luggage, avoid slopes, and adjust tire pressure according to vehicle load.
- Check the tire pressure of the spare tire or emergency spare tire at the same time.
- Install and tighten the valve cap.

i NOTE

- The current tire pressure of the wheel can be checked through the information on the display of the instrument cluster.
- Be sure to refit the valve cap to the valve core. The valve cap can prevent dust and moisture from entering the tire.

⚠ WARNING

- **Abnormal tire pressure may cause tire burst, resulting in a traffic accident, injury or even death.**
- **Check the tire pressure at least once a month and before long-distance driving. The tire pressure must meet the specified requirements to prevent accidents.**
- **Insufficient tire pressure will exacerbate tire deflection, and tires are extremely prone to overheating, which may lead to tread separation and tire burst.**
- **Abnormal tire pressure, too low or too high, will cause early wear of tires and reduce the maneuvering stability of the vehicle.**

Service life of tires

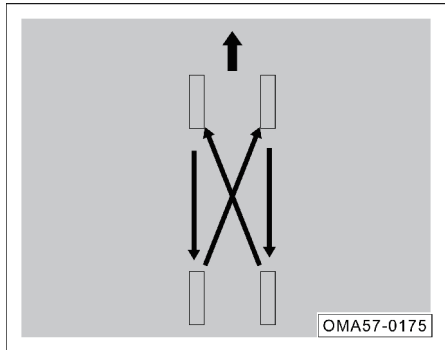

Service life of tires depends on tire pressure, driving style and tire assembly conditions.

If the front tires are worn more serious than the rear tires, it is recommended to perform tire rotation for the front and rear wheels as shown, so as to make the service life of all tires about the same.

👁 CAUTION

This vehicle is equipped with a tire pressure monitoring system. Tire rotation or replacement needs to be operated by professionals at the GAC Motor authorized shop.

6. In-service maintenance

Tire wear indicator

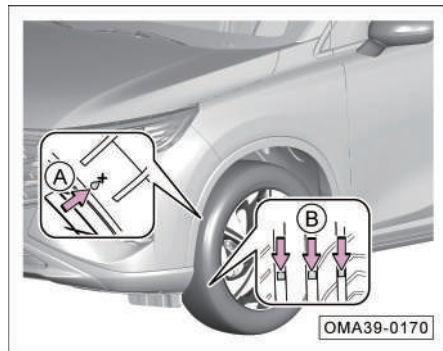

- Arrow A - the tire outer circle pattern is used to indicate the wear condition of the tire tread pattern. If the tire outer circle pattern wears to the condition as shown, the tire can no longer be used safely and must be replaced immediately.
- Arrow B - the raised tread wear indicator mark ② is 1.6 mm high. If the tread pattern wears to the marked surface, the tire can no longer be used safely and must be replaced immediately.

Wheel balance

The wheels of the new vehicle are already balanced. Due to various reasons, the wheels may go unbalanced during operation, which can be manifested by the vibration of the steering mechanism.

Because unbalanced wheels can cause excessive wear on the steering system, wheel suspension mechanism and tires, the wheels shall be rebalanced.

In addition, wheels must be rebalanced after installation of a new tire or tire repair for any wheel.

Wheel misalignment

Wheel misalignment will cause uneven and excessive wear of the tires, affecting driving safety. If uneven and excessive wear of the tires is found or the vehicle is obviously running sideways, please go to the GAC Motor authorized shop to check the wheel alignment as soon as possible.

6.8 Tire chain

In winter, driving in harsh environments such as snowy or icy roads can increase the degree of tire wear or cause other failures. To reduce failures in winter, the following opinions must be followed:

- When driving in deep snow, it is necessary to install tire chains on the tires. If so, be sure to choose an equivalent product whose size and type meet the specifications of the tires on the vehicle. Failure to do this will adversely affect the performance and safety of the vehicle. Moreover, operations such as full-load driving, speeding, emergency acceleration, emergency braking, and emergency turning are potentially dangerous.
- During deceleration, make full use of the engine braking function. Emergency braking on snowy or icy roads will cause the vehicle to flick and slip. Maintain an appropriate safety distance from the vehicle in front, step on the brake pedal slightly, and pay attention to that installing tire chains on the tires can increase certain friction force, but can not prevent side slipping.

NOTE

Various countries and regions have different regulations on tire chains. Before assembling tire chains, please refer to the laws and regulations of the corresponding country and region. Do not install tire chains without understanding the laws and regulations of the corresponding country and region that may restrict the use of tire chains.

CAUTION

- For installation of tire chains on all tires, ensure that the vehicle can be driven in a balanced manner in all weathers. It shall be borne in mind that after installation of tire chains, the vehicle power may be insufficient. Even if the road surface is in good condition, drive carefully. When driving, do not exceed the specified speed limit of tire chains, nor exceed 50 km/h, whichever is lower.

CAUTION

- If tire chains are installed on the tires, the size and type of tire chains shall be consistent with those of the standard tires of the vehicle. Otherwise, the driving safety and maneuvering of the vehicle will be adversely affected.
- Tire chains must be installed in pairs on the front wheels rather than on the rear wheels.
- Do not install the tire chain on an emergency spare tire. If a spare tire is installed on the front wheel and a tire chain is required, be sure to exchange the positions of the spare tire and the rear tire.
- Do not use tire chains on dry ground. After driving to snow-free roads, remove tire chains.
- After installing the tire chains as closely as possible to the front tires, drive 0.5~1.0 km, and then tighten the tire chains again.

7. Technical data

7.1 VIN

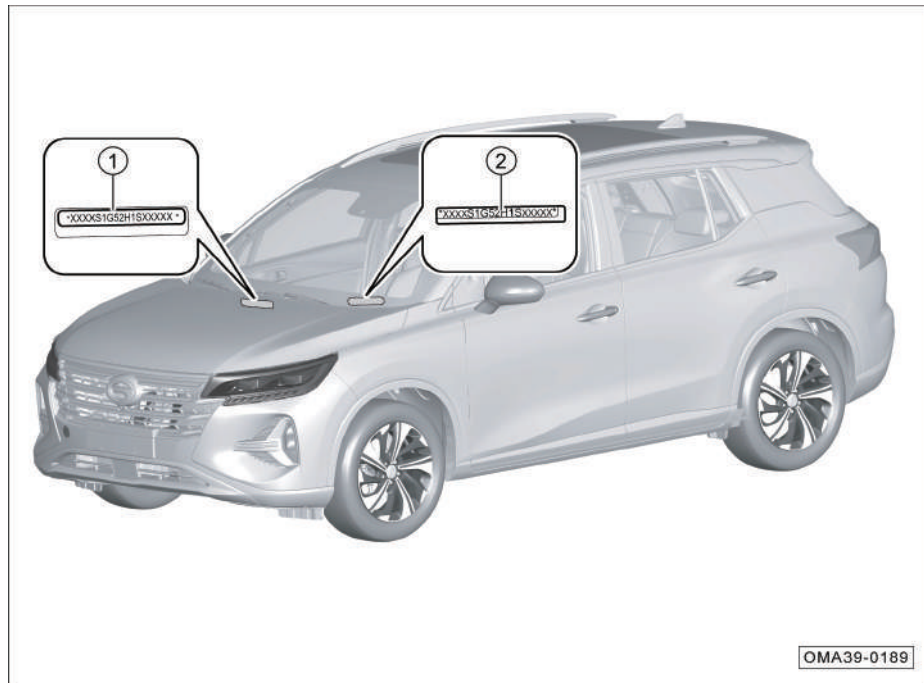

The locations of the vehicle identification number (VIN) is shown in the figure:

- ① VIN: located on the engine compartment partition.
- ② VIN: located on the left side of the instrument panel.

i NOTE

The position indication and quantity of vehicle identification number (VIN) are not complete. Please refer to the actual vehicle.

OBd (on-board diagnostic) interface

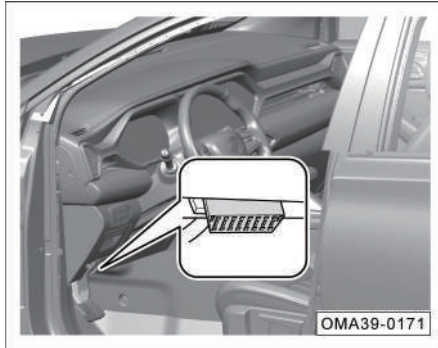

The OBD interface for reading the electronic VIN is located at the lower left rear of the instrument panel. Data such as the electronic VIN and vehicle status information can be read through a special scan tool.

i NOTE

If you need to buy a scan tool, you can go to the GAC Motor authorized store for consultation and purchase.

Vehicle nameplate

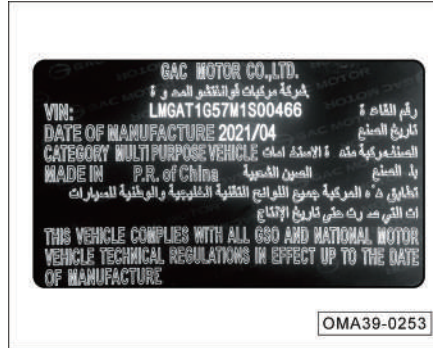

The nameplate of this vehicle is attached to the B-pillar on the driver's side.

Engine number

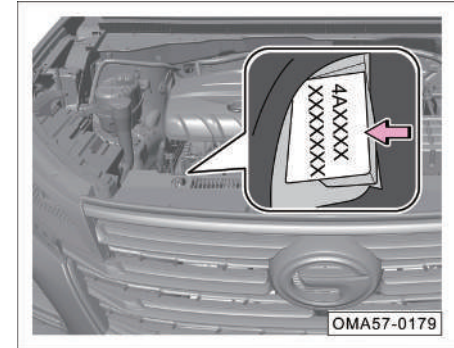

Engine model and factory number as arrowed are indicated on the engine block (behind the alternator).

7. Technical data

7.2 Vehicle parameters

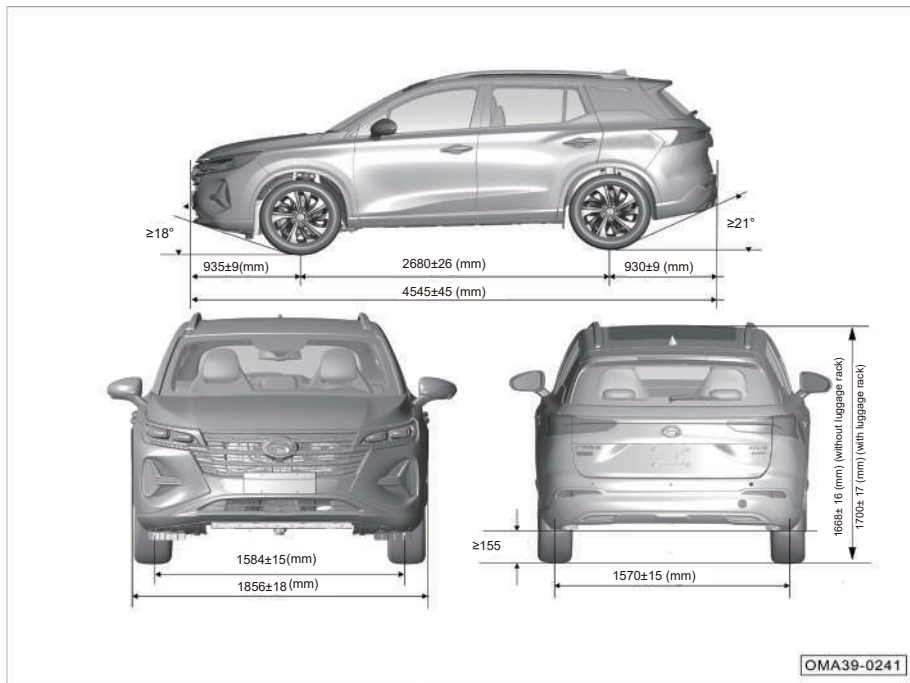

Dimensions

Item	Parameter		
	Numerical value	Unit	
Overall length	4545 ± 45	mm	
Overall width	1856 ± 18	mm	
Overall height	1668± 16 (without luggage rack)	mm	
	1700± 17 (with luggage rack)		
Wheel base	2680 ± 26	mm	
Wheel track	Front wheel	1584 ± 15	mm
	Rear wheel	1570 ± 15	mm
Front suspension	935 ± 9	mm	
Rear suspension	930 ± 9	mm	
Minimum ground clearance (full load)	≥ 155	mm	
Approach angle (full load)	≥ 18	°	
Departure angle (full load)	≥ 21	°	

Note: external rearview mirrors (respective one on the right and left) near the junction of the lower end of the A pillar and the front door and the antenna above the rear of the roof are not included in the overall width.

7.3 Vehicle mass & parameters of engine and fluids

Weight

Product model	Kerb mass of complete vehicle (kg)			Maximum gross mass (kg)		
	Kerb mass	Front axle load	Rear axle load	Maximum gross mass	Front axle load	Rear axle load
GAC6451A1G6	1480 ± 44	860 ± 25	620 ± 18	1955	1065	890
GAC6451A2G6	1520 ± 45	875 ± 26	645 ± 19			
GAC6451A1H6	1500 ± 45	875 ± 26	625 ± 18			
GAC6451A2H6	1540 ± 46	888 ± 26	652 ± 19			

Comprehensive parameters

Item	Performance parameters		Unit
	GAC6451A1G6 GAC6451A2G6	GAC6451A1H6 GAC6451A2H6	
Number of occupants	5		Person
Minimum turning diameter	11000		mm
Maximum gradeability	≥ 40		%
Time required to accelerate from 0 km/h to 100 km/h after start	10.5	10.8	S
Maximum vehicle speed	185	185	km/h
Fuel consumption in urban running conditions	Start-stop system not available: 8.8 Start-stop system available: -	Start-stop system not available: 8.7 Start-stop system available: -	L/100 km
Fuel consumption in suburban running conditions	Start-stop system not available: 5.6 Start-stop system available: -	Start-stop system not available: 5.7 Start-stop system available: -	L/100 km
Fuel consumption in comprehensive running conditions	Start-stop system not available: 6.8 Start-stop system available: -	Start-stop system not available: 6.8 Start-stop system available: -	L/100 km

7. Technical data

Parameters of engine

Model	4A15J1
Type	Gasoline engine, spark-ignition, in-line, liquid-cooled, direct injection, double overhead camshafts, exhaust gas turbocharging
Number of cylinders (pcs)	4
Ignition order	1-3-4-2
Bore (mm)	75
Stroke (mm)	84.6
Displacement (mL)	1495
Compression ratio	9.8:1
Rated power/speed (kW/(r/min))	124/5000
Maximum net power/speed (kW/(r/min))	117/5000
Maximum torque/speed (N·m/(r/min))	265/ 1700 ~ 4000
Maximum net torque/speed (N·m/(r/min))	250/ 1700 ~ 4000
Stable idle speed (r/min)	700
Emission standard	China 6

Specifications and capacity of fuel/oil/fluid

Item	Specification	Capacity	
		Capacity	
Fuel ¹⁾	92# or above high-quality unleaded gasoline	Capacity	55L
Engine coolant ²⁾	DF-6, -35°C coolant	Capacity	7.0L
Engine oil:	Viscosity: SAE 5W-30 Quality level: API SN	Total ³⁾	4.5L
		Change ⁴⁾	4.0L
Transmission fluid	AW-1	Capacity	6.7L
Windshield washer fluid	44% methanol, and 56% water with hardness not more than 205 g/t	-	3.4L
A/C refrigerant	HFC-134A	-	470±20g
Brake fluid	DOT4	-	0.78L

Notes: 1) Long-term use of fuels with a sulfur content higher than the standard value may result in excessive emissions. Please pay attention and use fuels that comply with local standards for vehicles.

2) Including the coolant in the expansion tank and the residual coolant in the engine.

3) The oil capacity for overhaul of engine assembly.

4) Including the oil capacity for replacement of oil filter.

7. Technical data

7.4 Specifications of transmission, chassis and bulb

Transmission parameters

Type	6MT
Final drive ratio	4.315
1st gear	4.044
2nd gear	2.371
3rd gear	1.556
4th gear	1.159
5th gear	0.852
6th gear	0.672
Reverse gear	3.193

Suspension

Type	Front suspension	Rear suspension
	McPherson independent suspension	Multi-link independent suspension

Steering gear

Type	Rack and pinion mechanical steering gear
Power steering type	Electric power

Brake

Type	Vacuum booster, X-type hydraulic double circuit
Front wheel	Disc brake
Rear wheel	Disc brake
Parking brake	EPB and mechanical flexible shaft control acting on the rear brake

Dynamic balance of wheels

Designation		Residue dynamic unbalance
Front wheel	Inner side	≤ 8 g
	Outer side	≤ 8 g
Rear wheel	Inner side	≤ 8 g
	Outer side	≤ 8 g

Wheel

Rim specifications	6.5J×17, 7J×18	
Tire specifications	225/60R17*, 225/55R18	
Tire pressure	Front wheel	Rear wheel
	230kPa	230kPa
Specifications of spare rim	Temporary spare tire D16*, temporary spare tire R17*	
Pressure of spare tire	420kPa	

Note: The standard tire pressure data label of the original tire of this vehicle is attached under the B pillar on the driver's side.

Free travel of brake pedal

Designation	Parameter
Travel	118 ± 8 mm
Free travel	2 ~ 5 mm

Technical parameters of brake linings

Designation	Parameter
Wear limit of front wheel brake lining (excluding the backplate of brake lining)	2 mm
Wear limit of rear wheel brake lining (excluding the backplate of brake lining)	2 mm

Wheel alignment

Designation		Parameter
Front wheel	Single wheel toe-in	4'±3'
	Wheel camber angle	-14'±30'
	Kingpin caster angle	7°18'±45'
	Kingpin inclination angle	12°17'±45'
Rear wheel	Single wheel toe-in	0'±3'
	Wheel camber angle	-52'±30'

Battery

	Model	MTO (without start-stop system)
Parameter	Rated voltage	12 V
	Capacity at 20 hr	55 Ah
	Low temperature start current (EN)	530 A

Fuse

Instrument panel PDU	=> See page 255
Engine compartment PDU	=> See page 261

7. Technical data

Lamps

Lamps		Specification	Parameter
Front combination lamp	Auxiliary lamp*	H7 (Halogen)	55W
	High/low beam integrated lamp*	HB3 (Halogen)	60W
	High beam*	LED	/
	Low beam*	LED	/
	Daytime running lamp*	LED	/
	Front position lamp	LED	/
	Front turn signal lamp	WY21W	21W
Front fog lamp*		LED	/
Rear fog lamp		P21W	21W
Side turn signal lamp		LED	/
Rear combination lamp	Brake lamp	LED	/
	Rear position indicator	LED	/
	Rear turn signal lamp	WY16W (Halogen)	16W
	Reversing lamp	W16W (Halogen)	16W
License plate lamp		W5W (Halogen)	5W
High-mounted stop lamp		LED	/
Front roof lamp		LED	/
Rear roof lamp		LED	/
Trunk lamp		C10W (Halogen)	10W
Vanity mirror lamp*		14V1CP	1.4W

For replacement of bulbs => [See page 228](#), some bulbs are only suitable for certain models. The actual vehicle configuration shall prevail!

8.1 Driver's tools, first aid kit and spare tire

Driver's tools

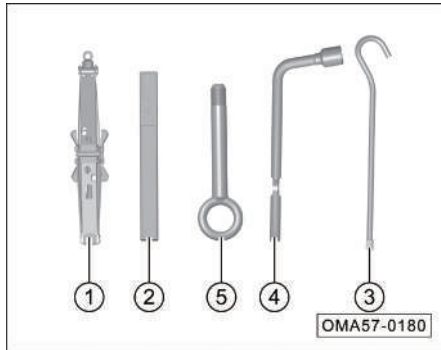

The following tools are provided with this vehicle and stored in the trunk=> [See page 103](#). After use, they shall be cleaned in time and placed back to the trunk.

- ① Jack
- ② Warning triangle
- ③ Special wrench for jack
- ④ Wheel bolt removal wrench
- ⑤ Towing hook

First aid kit

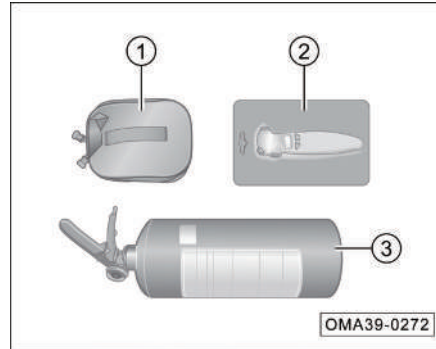

The first aid kit of this vehicle includes:

- ① Medical kit: it includes emergency and trauma care items for hemostasis, bandaging (such as, medical gauze, surgical tape, medical bandage made of breathable fabrics, triangular bandage, iodophor cotton stick, dressing forceps and safety scissors).
- ② Tire pressure gauge: used to measure tire pressure.
- ③ Portable dry powder fire extinguisher: used for putting out a fire quickly when the vehicle is on fire.

Spare tire

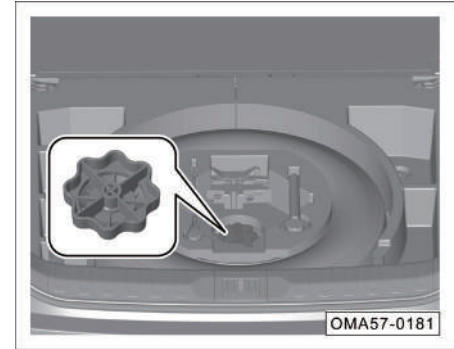

Remove the spare tire:

- Open the tailgate and take out the trunk carpet.
- Take out the driver's tool box.
- Turn spare tire center handwheel and take out the spare tire.

If the spare tire has been inflated, check its pressure regularly for several times every year to ensure that it is at the specified maximum tire pressure.

8. Accident handling

WARNING

- The spare tire shall be used strictly in accordance with its use requirements to avoid danger.
- It is strictly prohibited to install and use more than one spare tires at the same time.
- It is forbidden to use spare tires that have been damaged or worn to the limit.
- The storage and service life of spare tires is 6 years. It is prohibited to use them beyond the time limit.
- After installing the spare tire, check the tire pressure as soon as possible to keep it within the specified range.
- The maximum speed of spare tires must not exceed 80 km/h, and rapid acceleration and emergency braking shall be avoided.

8.2 Use of warning triangle

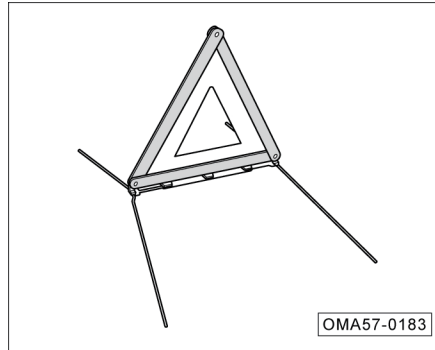

- Open the liftgate.
- Lift the trunk carpet.
- Take out the warning triangle and unfold it for use.

Placement distance

Ordinary highway		Expressway
Daytime	Night	
≥50m	≥80m	≥150m

CAUTION

The data above is for reference only. Please place the warning triangle at the distance specified by traffic regulations.

8.3 Use of reflective vest

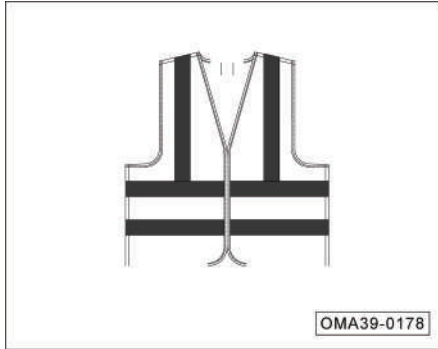

- If it is necessary to stop the vehicle due to an accident or other failures, take out the reflective vest from the glove box to put on it well before getting off the vehicle for checking and troubleshooting.

i NOTE

- When handling vehicle accidents, regardless of the lighting conditions, be sure to wear a reflective vest as required to attract the attention of passersby or other drivers.
- After using the reflective vest, please store it in the glove box properly. If necessary, clean it according to the collar mark to maintain the reflective performance.

8.4 Replacing flat tires

Preparations

- Apply the parking brake.
- Set the gearshift lever to the P gear.
- Turn the ENGINE START/STOP button to the "OFF" position, and turn on the hazard warning lamp.
- Place a warning triangle in a suitable position behind the vehicle.
- Find a suitable object to wedge the wheel in the diagonal position of the one to be replaced to prevent the vehicle from moving.
- Take out the driver's tools and spare tire.

⚠ WARNING

- **Relevant regulations must be strictly followed.**
- **All occupants must leave the vehicle and wait in a safe place.**

8. Accident handling

Unscrewing the wheel bolts



Set the wheel bolt removal wrench firmly on the wheel bolt, and unscrew the wheel bolts counterclockwise.

CAUTION

Unscrew the wheel bolts just one turn before lifting the vehicle. After lifting the vehicle, unscrew the wheel bolts completely, and then remove the flat tire.

Lifting the vehicle

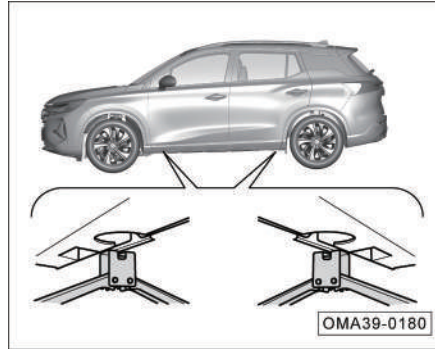

- Place the jack directly under the spine closest to the flat tire.
- Raise the jack to ensure that the groove of the jack can engage with the spine.
- Check whether the jack is stable and tightly attached to the ground.

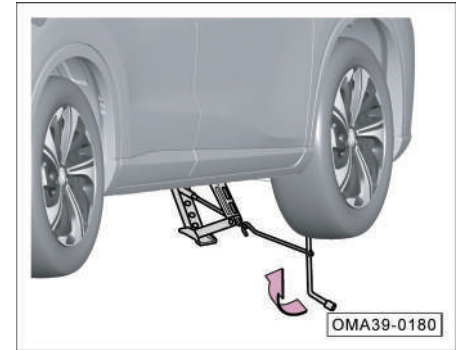

- Assemble the wheel bolt removal wrench, the special wrench for jack and the jack.
- Raise the jack clockwise to lift the vehicle and lift the tire off the ground.

WARNING

Improper use of jacks can cause serious injury.

- The jack must be used on a hard and flat ground, and a hard plate (plate height not more than 1 cm) can also be placed under the jack as needed.
- Strictly observe the precautions for jack operation.
- If a trailer is needed for towing, it must be separated from the vehicle.
- Observe the status of the vehicle continuously during the lifting process. If the vehicle body is noticeably tilted, stop the lifting, find the problem, and then lift the vehicle after solving the problem.

WARNING

- The jack provided with the vehicle can only be used to lift the vehicle, instead of lifting other heavy objects or vehicles.
- When using the jack, do not start the engine, otherwise an accident may occur.
- When lifting the vehicle with a jack, remember not to place any part of your body under the vehicle to avoid accidents.
- If it is required to work under the vehicle, be sure to place a suitable protective support under the vehicle.

Removing the flat tire

- With the vehicle lifted up, use a wheel bolt removal wrench to screw off the unscrewed wheel bolts.
- Remove the flat tire.

Installing the spare tire



- Install the spare tire to the vehicle.
- Install the wheel bolts, and pre-tighten them using the wheel bolt removal wrench in the order of ①~⑤ as shown.
- Give a verbal warning, and after confirming that nobody is around the vehicle, rotate the jack wrench counterclockwise to lower the vehicle.
- Tighten all wheel bolts using the wheel bolt removal wrench.
- In order to avoid the noise of the vehicle during driving later on, please remember the locations of various tools, put them back in place after use and fix them.

8. Accident handling

CAUTION

After installing the wheel, please go to the GAC Motor authorized shop in time to check the tightening torque of the wheel bolts ($125\pm 10\text{N}\cdot\text{m}$). Otherwise, the bolts may loosen while the vehicle is running, which is prone to cause traffic accidents.

WARNING

- The thread on the wheel bolt and the hub must be kept clean, so that the bolt is easy to be screwed, and no adherent matters such as grease is allowed on it.
- During replacement of a tire, if the bolts are rusted or difficult to be screwed, they must be replaced and the threaded hole cleaned.
- When the spare tire is not in use, it must be securely fixed in the place where the spare tire is mounted.

8.5 Microwave window

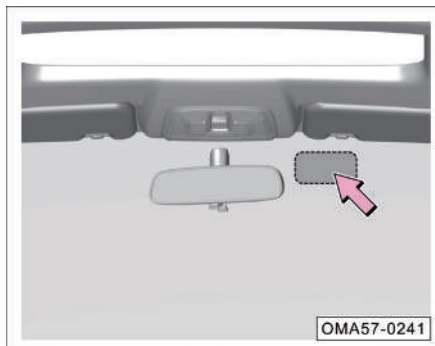

- The microwave window is set on the right of the front windshield corresponding to the interior rearview mirror.

NOTE

The microwave window can be used for installation of ETC card.

8.6 Fuse

Instrument panel PDU



- Open the cab lower protective plate storage box as arrowed and pull it out to see the fuse above the instrument panel PDU.

Engine compartment PDU

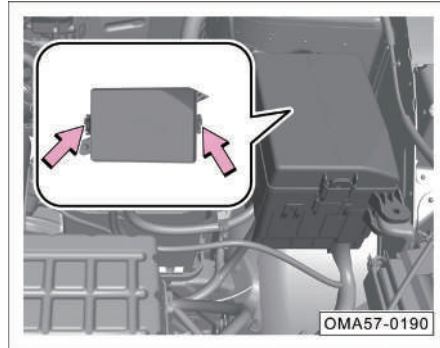

- Open the engine hood.
- Press the fixing clip as arrowed to release the cover of the PDU.
- The fuse above the engine compartment PDU is exposed when the cover of the PDU is removed.

Replacing the fuse

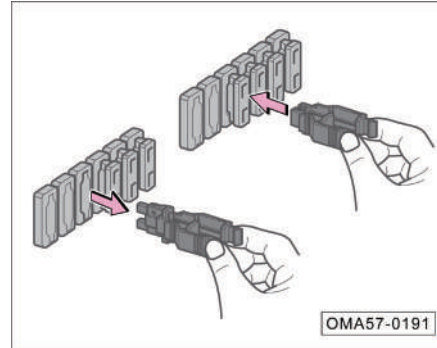

- Pull out or install the fuse using the fuse puller in the engine compartment PDU.

Blown fuse

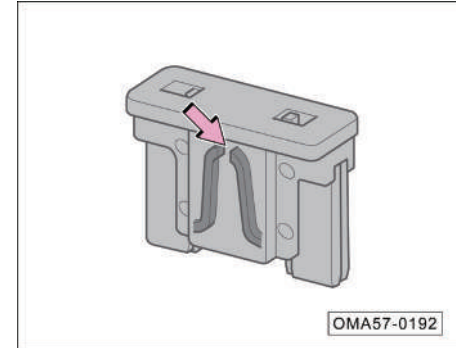

- If the fuse has blown (as arrowed), it is recommended to replace it with a new fuse of the same color and identification in a GAC Motor authorized shop.

8. Accident handling

NOTE

Some electrical units may be equipped with multiple fuses each, or multiple electrical consumers may share a single fuse.

CAUTION

- All electrical consumers must be turned off before replacement of fuses.
- If it is required to replace the fuse, please consult the GAC Motor authorized shop.

WARNING

- **Fuses must not be reused.**
- **Do not use a fuse with rated current higher than the specified value, otherwise other components of the electrical system will be damaged.**
- **Using an inappropriate or repaired fuse may cause a fire or even casualties.**
- **The color and logo of the replaced fuse must be exactly the same as the original one.**
- **Never replace a fuse with metal sheets, clips, etc.**
- **The PDU must be kept clean inside. Pay attention to protection against moisture.**

8.6.1 Fuses in instrument panel PDU

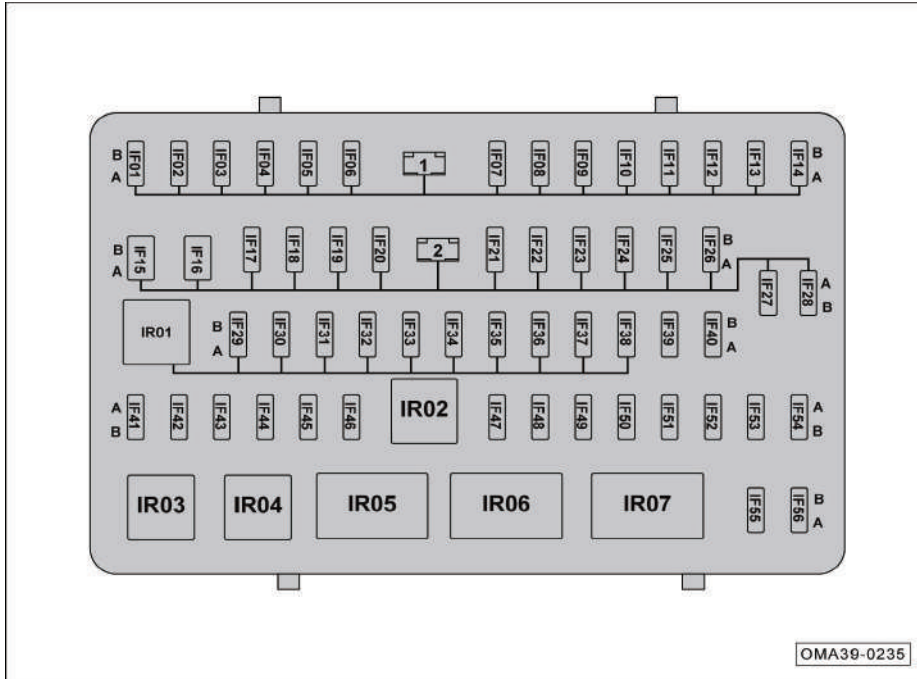

The fuses may slightly vary from vehicle to vehicle. In this regard, the actual vehicle shall prevail.

8. Accident handling

No.	Rated value	Feature/part
IF01	-	-
IF02	20A	Left/right front seat adjustment
IF03	20A	Ordinary sunroof*/Panoramic sunroof*, sunroof sunshade motor*
IF04	-	-
IF05	20A	Right front window
IF06	20A	Left front window
IF07	20A	Right rear window
IF08	20A	Left rear window
IF09	7.5A	Wireless control module *
IF10	-	-
IF11	15A	Rear wiper
IF12	10A	Rearview mirror folding relay*/ rearview mirror unfolding relay*
IF13	-	-
IF14	-	-
IF15	30A	DC-DC converter *
IF16	30A	DC-DC converter *
IF17	7.5A	OBD (on-board diagnostic) interface
IF18	20A	Body control module B2
IF19	7.5A	PEPS control unit 2 *, gateway control unit*

No.	Rated value	Feature/part
IF20	7.5A	Shift lever control unit
IF21	10A	Trunk lamp
IF22	-	-
IF23	7.5A	PEPS ECU*/PEPS switch
IF24	20A	Body control module*
IF25	-	-
IF26	20A	Door lock
IF27	-	-
IF28	Shunt	-
IF29	10A	Airbag control unit
IF30	7.5A	ECM/6AT TCU
IF31	7.5A	Gateway control unit*, body control unit/DC-DC converter *, PEPS control unit*
IF32	-	-
IF33	7.5A	Gearshift lever control unit/SAS/electric power steering control unit
IF34	7.5A	Brake switch, ESP control unit
IF35	7.5A	Left headlamp, right headlamp, headlamp leveling switch, AFS control unit *
IF36	-	-

8. Accident handling

No.	Rated value	Feature/part
IF37	7.5A	Left/right headlamp, headlamp leveling switch, AFS control unit *
IF38	7.5A	General sunroof ECU*/left front seat electric adjustment*/RLS/central control module/plasma generator*/left instrument panel switch block/front control panel
IF39	15A	6AT control unit
IF40	15A	AV system USB2
IF41	7.5A	PEPS ECU*/BCM
IF42	7.5A	Wireless control module*, USB charging
IF43	-	-
IF44	7.5A	Left front seat electric adjustment *, AV system control unit, left exterior rearview mirror
IF45	-	-
IF46	20A	Cigar lighter
IF47	7.5A	Blower relay/defogger relay*/auto dimming interior rearview mirror*
IF48	-	-
IF49	-	-
IF50	7.5A	Body control module, engine control unit
IF51	-	-

No.	Rated value	Feature/part
IF52	7.5A	AFS control unit*
IF53	7.5A	Left/right front door handle switch
IF54	7.5A	Front left seat electric adjustment *, automatic lift door system 24V *, power tailgate switch, central control module, left front door centralized control switch, PM2.5 sensor *
IF55	15A	Body control module
IF56	7.5A	HCP/AV system*/instrument cluster/AVM ECU*/LDW ECU*/FCP*
IR01	-	IG1 relay
IR02	-	IG2 relay
IR03	-	-
IR04	-	-
IR05	-	ACC relay
IR06	-	Rearview mirror folding relay*
IR07	-	Rearview mirror unfolding relay*

8. Accident handling

8.6.2 Fuses in engine compartment PDU

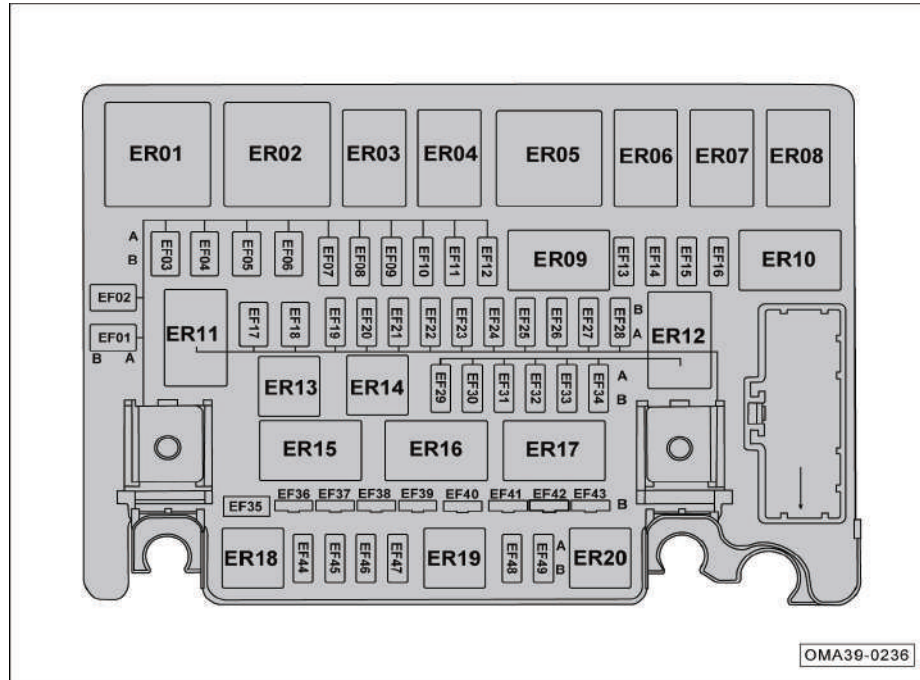

The fuses may slightly vary from vehicle to vehicle. In this regard, the actual vehicle shall prevail.

8. Accident handling

No.	Rated value	Feature/part
EF01	50A	Left radiator fan relay
EF02	-	-
EF03	-	-
EF04	40 A/60 A	Electronic stability and parking control module
EF05	-	-
EF06	30A	Power tailgate control unit*
EF07	7.5A	Compressor relay
EF08	-	-
EF09	-	-
EF10	20A	Left front VSM*
EF11	7.5A	Forward radar module*
EF12	-	-
EF13	15A	Left front low beam
EF14	15A	Right front low beam
EF15	7.5A	Engine control unit, DC-DC converter
EF16	7.5A	Left and right rearview mirrors
EF17	40A	TCU
EF18	40A	IG1, ACC
EF19	7.5A	Low beam relay
EF20	-	-
EF21	-	-

No.	Rated value	Feature/part
EF22	-	-
EF23	20A	Fuel pump relay
EF24	20A	Wiper relay 1, wiper relay 2
EF25	7.5A	Engine control unit, brake switch
EF26	15A	Horn relay
EF27	10A	TCU, AGS
EF28	15A	High beam relay
EF29	7.5A	Electronic water pump
EF30	10A	Oil pump solenoid valve, intake and exhaust solenoid valve, waste gas valve, relief valve, clutch switch*, canister control valve, canister shut-off valve
EF31	10A	Upstream oxygen sensor, downstream oxygen sensor
EF32	15A	ECM
EF33	15A	Ignition coil 1/ignition coil 2/ignition coil 3/ignition coil 4
EF34	10A	Fuel pump relay/left cooling fan/right cooling fan
EF35	80A	Electric power steering control unit
EF36	40A	Instrument panel PDU
EF37	40A	Blower relay
EF38	40A	ESPI

8. Accident handling

No.	Rated value	Feature/part
EF39	40A	Defogger relay
EF40	150A	Alternator
EF41	30A	Starter relay 1, starter relay 2
EF42	50A	Right radiator fan relay
EF43	50A	Instrument panel PDU
EF44	-	-
EF45	-	-
EF46	-	-
EF47	-	-
EF48	-	-
EF49	-	-
ER01	-	Left cooling fan
ER02	-	Right cooling fan
ER03	-	Fuel pump relay
ER04	-	-
ER05	-	High-speed radiator fan relay
ER06	-	Wiper relay 1
ER07	-	Wiper relay 2
ER08	-	-
ER09	-	Defogger relay*
ER10	-	-

No.	Rated value	Feature/part
ER11	-	Low beam relay
ER12	-	Main relay
ER13	-	Compressor relay
ER14	-	-
ER15	-	Starter relay 1
ER16	-	Starter relay 2
ER17	-	Blower relay
ER18	-	-
ER19	-	Horn relay
ER20	-	High beam relay

8.6.3 Fuses in battery PDU

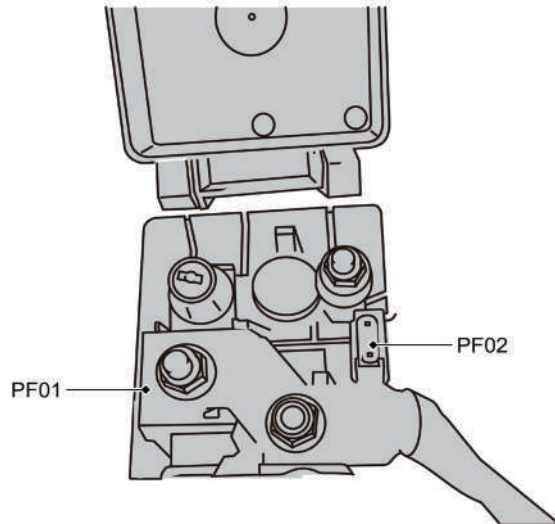

The fuses may slightly vary from vehicle to vehicle. In this regard, the actual vehicle shall prevail.

No.	Rated value	Feature/part
PF01	300A	Starter/engine compartment PDU, alternator
PF02	7.5A	Battery sensor

OMA39-0275

8. Accident handling

8.7 Emergency start

Jumper cable

If the engine cannot be started due to low battery, it can be started by connecting this battery to the battery of another vehicle with jumper cables.

CAUTION

Make sure that the clamp of the jumper cable does not touch other metals.

WARNING

- The engine compartment is a high-risk area. Improper operation can easily cause casualties.
- Before starting work on the battery, be sure to carefully read and follow the warning instructions for safety related to battery operation.

When connecting the batteries of two vehicles, be sure to first connect the positive terminal and then the negative terminal.

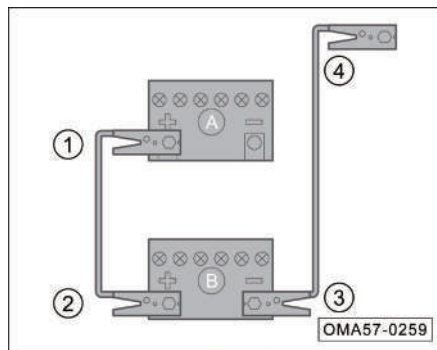

- Switch the ENGINE START/STOP button to the "OFF" position.
- Connect the ① end of the red cable to the positive terminal (+) of the depleted battery "A", and the other end ② to the positive terminal (+) of the power battery "B".

- Connect the ③ end of the black cable to the negative pole (-) of the power battery "B", and connect the other end ④ to the engine block, or a metal part firmly connected to the engine block, of the vehicle with the depleted battery "A".

CAUTION

Properly place the jumper cable to avoid contact between the cable and the moving parts of the engine.

- Start the engine of the vehicle with power battery and let it idle. Then, start the engine of the vehicle with the depleted battery till the engine runs smoothly.

WARNING

- Be sure to turn off the headlamps before removing the jumper cables.
- Turn on the blower and rear windshield heater of the vehicle with the depleted battery to reduce the voltage peak generated when the cable is being removed.
- Remove the jumper cables in the reverse order with the engine running.

WARNING

Improper use of jumper cables may cause battery explosion and serious injury.

- The voltage of the power battery must be the same as that of the depleted battery, and the capacity of the two batteries shall also be the same. Otherwise, it may cause an explosion.
- Never expose the battery to an open flame, for fear of an explosion.
- Never connect the negative cable directly to the negative terminal of a depleted battery. There shall be no static electricity near the battery. Otherwise, the combustible gas produced by the battery may be ignited by sparks, causing an explosion accident.
- Never connect the negative cable to fuel system components or brake lines. Never lean over the battery during operation. Be careful not to get burned by acid.

8.8 Towing

If the vehicle needs to be towed, it shall be towed by the GAC Motor authorized shop or a professional towing company.

It is recommended to use a rollback tow truck for towing. If the conditions cannot be met, a wheel-lift truck can also be used for towing according to the situation.

Towing by a rollback tow truck

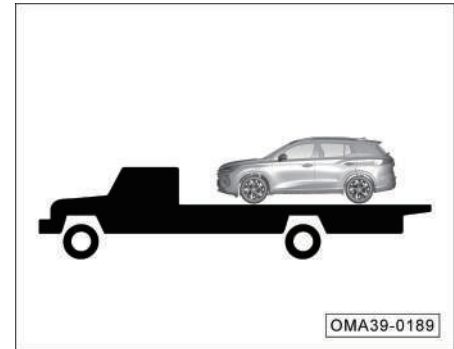

8. Accident handling

Towing by a wheel-lift truck from the front

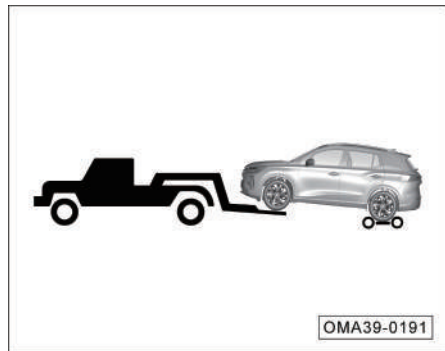

- Place a dolly under the rear wheels.

Towing by a wheel-lift truck from the rear

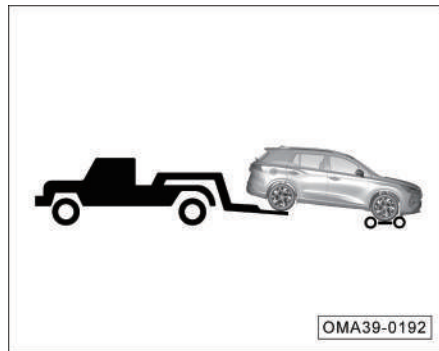

- Place a dolly under the front wheels.

Emergency towing

If it is impossible to find a tow truck in an emergency, fasten the towing cable or towing chain in the emergency towing ring to temporarily tow the vehicle. However, this method is only suitable for low speed and short distance towing on a solid and flat road.



WARNING

In emergency towing, drive slowly to avoid violent operation. Excessive towing force will damage the vehicle.

Installing a towing hook

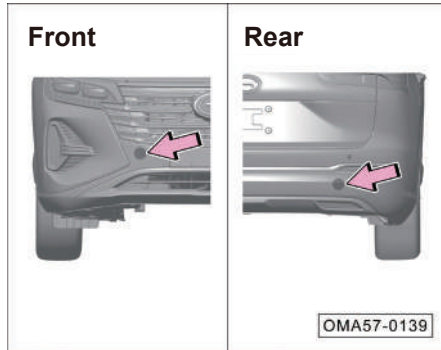

- Pry off the towing hook cover in the arrowed position using a slotted screwdriver wrapped with a cloth.

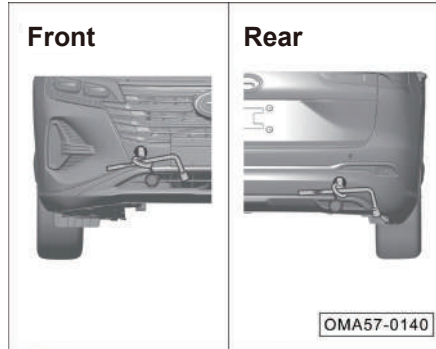

- Take out the towing hook ① and wheel bolt removal wrench ② from the driver's tool kit in the trunk.
- Screw the towing hook ① clockwise into the threaded hole.
- Insert the wheel bolt removal wrench ② into the round opening of the towing hook, and turn the wheel bolt removal wrench clockwise to make the towing hook be firmly screwed into the threaded hole.

Precautions for towing

Before emergency towing, be sure to follow the instructions below:

- Hazard warning lamps of both towing and towed vehicles must be turned on, and local traffic regulations must be complied with.
- The towing hook must be firmly tightened in the threaded hole. Otherwise, the towing hook may slip out of the threaded hole during towing.
- For the towed vehicle, the gearshift lever must be switched to the "N" position.
- For the towed vehicle, set the ignition switch to the "ON" position and turn the steering wheel back and forth to confirm that the steering wheel can be turned.

8. Accident handling

During the emergency towing, be sure to follow the instructions below:

- Start the engine and drive at a slow speed till the towing rope is tight and then accelerate the vehicle slowly.
- Be sure to drive steadily and avoid sharp acceleration, sharp deceleration or abrupt turning.
- During towing, the towed vehicle shall be braked earlier than in normal conditions, with the brake pedal lightly depressed.
- During towing, the towing rope must always be in a tight state.

8.9 Getting out of a trap

If the vehicle is stuck on a soft road such as sandy, muddy or snowy road, follow the steps below to get out of a trap:

1. Observe the areas in front of and behind the vehicle to ensure that there are no obstacles.
2. Turn the steering wheel left and right to grind areas around the front wheels to remove mud, snow or sand trapped around the tires.
3. Place wooden blocks, stones or other materials to help increase tire friction.
4. Start the engine and accelerate the vehicle slowly to get the vehicle out of the pit.
5. If the vehicle still cannot get out of the trap after attempts for several times, it is required to have a tow truck for rescue.

i NOTE

In the acceleration process, human assistance can be provided to push the vehicle from the front and rear for driving the vehicle out of the trap.

This manual describes related information of entire GAC Motor series, including their configuration, functions, performance parameters and product schematic diagrams. Its content is valid when allowed to be printed. However, the actual configuration and function of the vehicles are subject to the specific vehicles delivered. If there is any difference between the schematic diagrams and the specific vehicle delivered, the actual vehicle shall prevail.

GAC Motor Co., Ltd. reserves the right to change, supplement or terminate the contents and technical specifications in this manual without prior notice.

GAC Motor Co., Ltd. owns the copyright of this manual. Without the written consent of GAC Motor Co., Ltd., it is not allowed to photocopy or extract the contents of this manual.

GAC Motor Co., Ltd.