

Thanks for choosing the vehicle manufactured by GAC Motor Co., Ltd. (hereinafter referred to as “GAC Motor”). For a better driving pleasure, please read the *Owner’s Manual* carefully. Through this manual, you can fully understand the operation methods and precautions of the vehicle. Proper operation of the vehicle can improve driving safety and prolong the service life of the vehicle.

The *Warranty Manual* supplied with the vehicle clearly describes the warranty services provided by GAC Motor and the regular maintenance of the vehicle. Please read this manual carefully to know your rights and responsibilities.

After reading this manual, please store it with the vehicle for future reference.

In case of any doubts about this manual, please contact the GAC Motor authorized shop for detailed explanation.

If you have any suggestions or recommendations, please contact GAC Motor through the customer service hotline: +86-400-158-9999.

We are grateful for your support and love for GAC Motor. Have a nice drive!

GAC Motor Co., Ltd.

## Reading Instructions



---



The safety of you and the passengers is crucial, so driving safely is an important responsibility of the driver.

In order to make clear the safety precautions, we provide operation steps and precautions through the various signs on the vehicle and this manual, reminding you to pay attention to the potential dangers that will hurt you or the passengers.

It is impossible to list all the precautions for danger related to operation and maintenance of the vehicle in the manual, so it is up to you to make the correct judgment in time.

Safety instructions are available in many forms, including:

- **Safety signs** - pasted on the vehicle.
- **Safety notes** - the texts marked with the symbols , ,  and one of the three words "WARNING", "CAUTION" or "NOTE" in front.

 <b>WARNING</b>
 <b>CAUTION</b>
 <b>NOTE</b>

Very important instructions of which the nonobservance can cause casualties.

Important instructions of which the nonobservance can cause damage to the vehicle.

General instructions of which the nonobservance could not cause injuries.

- Some paragraphs of this manual do not apply to all vehicle models. For the description of options, the title text is followed by the symbol "\*\*".
- Unless otherwise specified, the directions of the vehicle (front, rear, left and right) referred to in this manual are based on the traveling direction of the vehicle.

<b>1. Important Safety Precautions.....</b>	<b>1</b>
<b>2. Pictorial References.....</b>	<b>3</b>
2.1 Exterior .....	3
2.2 Interior .....	6
<b>3. Safety Operating Instructions .....</b>	<b>10</b>
3.1 Safe driving.....	10
3.1.1 General description.....	10
3.1.2 Correct sitting posture of the driver and passengers .....	11
3.2 Seat belt .....	12
3.2.1 Why must you fasten the seat belt.....	12
3.2.2 Seat belt.....	14
3.3 Supplemental restraint system (SRS) .....	18
3.3.1 Cases where the airbags may deploy.....	24
3.3.2 Cases where the airbags might not deploy .....	25
3.4 Safe ride of children.....	26
3.4.1 General description.....	26
3.4.2 Child safety seat .....	27
3.4.3 Information about child safety seat.....	29
3.4.4 Correct installation of child safety seat ...	31
3.5 Exhaust gas hazard .....	35

3.6 Safety label.....	36
<b>4. Operation of systems and equipment .....</b>	<b>37</b>
4.1 Cab .....	37
4.1.1 Steering wheel .....	37
4.1.2 Instrument cluster .....	39
4.1.3 Indicator lamp .....	46
4.2 Vehicle locking and unlocking.....	50
4.2.1 Remote control key .....	50
4.2.2 Emergency mechanical key .....	54
4.2.3 Door lock system .....	55
4.2.4 Door .....	60
4.2.5 Liftgate .....	61
4.2.6 Engine hood.....	66
4.2.7 Power window.....	67
4.2.8 Power sunroof* .....	69
4.2.9 Basic operation of body anti-theft system .....	74
4.3 Lamps and vision.....	75
4.3.1 Exterior lamps.....	75
4.3.2 Interior amp.....	81
4.3.3 Wiper combination switch .....	85
4.3.4 Windshield .....	87
4.3.5 Rearview mirror .....	87
4.3.6 Sun visor .....	90

# Contents

---

4.4	Seats and storage facilities.....	91	4.7	Emergency rescue.....	138
4.4.1	Headrest .....	91	<b>5. Driving guide.....</b>	<b>139</b>	
4.4.2	Front seats.....	92	5.1	Starting and driving.....	139
4.4.3	Second/third-row seat.....	95	5.1.1	ENGINE START/STOP button.....	139
4.4.4	Storage facilities .....	97	5.1.2	Engine start.....	140
4.4.5	Power outlet/USB port .....	101	5.1.3	Engine shutdown .....	141
4.4.6	Mobile phone wireless charging system* .....	103	5.1.4	Gear description .....	142
4.4.7	Trunk.....	106	5.2	Braking system .....	145
4.4.8	Luggage rack .....	107	5.2.1	Service brake .....	145
4.4.9	Accessories and modification .....	107	5.2.2	Electric park brake (EPB) .....	148
4.5	A/C system .....	109	5.3	Electronic service brake system .....	152
4.5.1	General description.....	109	5.3.1	Electronic stability program (ESP) .....	152
4.5.2	A/C system .....	110	5.3.2	Anti-lock braking system (ABS) .....	154
4.5.3	A/C air outlet.....	117	5.3.3	Hill hold control (HHC) .....	156
4.6	AV system.....	120	5.3.4	Hill descent control (HDC) .....	156
4.6.1	Buttons on the right of the steering wheel .....	120	5.3.5	Hydraulic boost failure compensation (HBC).....	157
4.6.2	Basic operation .....	121	5.4	Driver assistance systems .....	158
4.6.3	Radio .....	126	5.4.1	Cruise control* .....	158
4.6.4	Local music.....	127	5.4.2	Adaptive cruise control (ACC)* .....	159
4.6.5	Bluetooth function .....	128	5.4.3	Integrated cruise assist (ICA)* .....	169
4.6.6	System setting (applicable to cars with AV main unit) .....	130	5.4.4	Forward collision mitigation (FCM)* .....	174
4.6.7	Settings (applicable to vehicles with AVN unit).....	132	5.4.5	Traffic sign recognition* .....	179
			5.4.6	Lane departure warning (LDW) system*.....	182

5.4.7	Shadow driver.....	187	5.8.3	Driving essentials.....	240
5.4.8	Intelligent headlight control*.....	188	5.8.4	Efficient use of vehicle .....	242
5.4.9	Adaptive driving beam system* .....	190	5.8.5	Fire prevention.....	242
5.4.10	Blind spot detection (BSD) system* .....	192			
5.4.11	Rear crossing traffic alert (RCTA)*.....	195	<b>6. In-service maintenance.....</b>	<b>244</b>	
5.4.12	Rear approach alert system* .....	197	6.1	Maintenance instructions.....	244
5.4.13	Door open warning (DOW)*.....	199	6.2	Interior maintenance.....	244
5.4.14	Emergency lane keep aid (LKA) system* .....	201	6.3	Exterior maintenance.....	246
5.4.15	Radar and camera sensor*.....	204	6.4	Inspecting and adding fluids.....	250
5.4.16	Tire pressure monitoring system (TPMS) .....	207	6.4.1	Fuel.....	250
5.4.17	Cabin monitoring system*.....	208	6.4.2	Engine oil .....	253
5.4.18	Interior monitoring radar system *.....	212	6.4.3	Coolant .....	256
5.4.19	Head-up display (HUD)* .....	213	6.4.4	Windshield washer fluid and wiper blades .....	259
5.5	Parking assist system (PAS).....	217	6.4.5	Brake fluid.....	261
5.5.1	Reversing parking aid (RPA) system ....	217	6.4.6	Battery .....	263
5.5.2	Reverse image system * .....	221	6.5	A/C filter.....	265
5.5.3	Around view monitor (AVM)*.....	224	6.6	Replacing bulb.....	265
5.5.4	APA *.....	231	6.7	Wheels.....	266
5.6	Electric power steering (EPS).....	236	6.8	Tire chain .....	271
5.7	Off-road modes * .....	237	<b>7. Technical data.....</b>	<b>272</b>	
5.8	Driving skills.....	238	7.1	VIN.....	272
5.8.1	Pre-driving safety inspection.....	238	7.2	Dimensions & parameters of vehicle .....	274
5.8.2	Driving during running-in period.....	239			

# Contents

---

7.3	Vehicle mass & parameters of engine and fluids .....	275
7.4	Specifications of transmission, chassis and bulb .....	279
<b>8.</b>	<b>Accident handling .....</b>	<b>288</b>
8.1	Driver's tools and spare tire .....	288
8.2	Use of warning triangle .....	290
8.3	Use of reflective vest .....	291
8.4	Replacing flat tires .....	291
8.5	Microwave window .....	294
8.6	Fuse.....	295
8.7	Emergency start .....	297
8.8	Vehicle towing.....	299
8.9	Getting out of a trap .....	301

# 1. Important Safety Precautions

## ◆ Be sure to fasten the seat belt correctly

The seat belt is the best protection device in the event of a collision. Airbags are only designed as auxiliaries, rather than replacements, of the seat belts, so even if the vehicle is equipped with airbags, make sure that you and the passengers always fasten the seat belts correctly.

## ◆ Do not leave children in an unattended vehicle

Do not leave children in an unattended vehicle, as injury or even death may occur if they trigger a control device accidentally, or when the vehicle is moved accidentally and collided with other objects due to their mis-operation, and besides, the temperature inside the vehicle may reach an extreme condition, depending on the ambient temperature.

## ◆ Protect all children

Children aged 12 or under should be properly restrained in the 2nd-row seats rather than the front seats. Child safety seats shall be used for infants and toddlers; and child safety seats and three-point seat belts shall be used for older children, until it can be assured that the children can fasten the seat belts (without booster seats) properly.

## ◆ Beware of danger of airbag

Airbags can save lives, but they can also cause serious or fatal injuries to occupants who are too close to the airbags or improperly restrained.

Airbags pose the greatest risk to infants, toddlers and short adults, so please follow all instructions and warnings in this manual.

## ◆ Never drink and drive

Drinking alcohol, even a little, will reduce your response capability, and your reaction time after drinking will become longer, so drinking and driving is strictly prohibited.

## ◆ During driving, please abide by the road traffic safety laws and yield to pedestrians.

## ◆ Be sure to pay attention to driving safety

Traffic accident will occur if you are busy answering the phone or handling other things so that you can not pay attention to road conditions, other traffics and pedestrians during driving. Please avoid distraction during driving.

## ◆ Control speed

Excessive speed is one of the main causes of traffic accidents. The faster the speed is, the greater the risk will be. Therefore, please choose the appropriate speed for safe driving according to the actual road conditions.

## ◆ Regular maintenance

Tire burst or mechanical failure is very dangerous. In order to reduce the possibility of such problems, please check the tire pressure and status frequently, and carry out regular maintenance as specified in the *Warranty Manual*.

# 1. Important Safety Precautions

---

## Event data recorder (EDR)

This vehicle is equipped with an event data recorder (EDR). The EDR is mainly designed to record data in the event of certain collisions (such as airbag deployment or collision with a barrier), so as to help understand the operation of the vehicle system. EDR is specially used to record data related to vehicle dynamic control and safety systems in a short period of time. However, depending on the severity and type of collision, data may not be recorded.

The data specially recorded by the EDR of this vehicle include:

- The depressed status of the brake pedal (if applicable).
- The vehicle speed.
- The longitudinal acceleration
- Vehicle identification number

These data help better understanding the situation in the event of a collision and personal injury, and are used to assist accident analysis.

### **i** NOTE

The EDR will record data only when a certain degree of collision occurs to the vehicle; EDR will not record data during normal driving.

## EDR data disclosure

Except for the following circumstances, GAC Motor will not disclose the data recorded in the EDR to third parties:

- Reaching an agreement with the owner (or the lessee of the rental vehicle).
- At the official request of the police, courts or government agencies.

If necessary, the data will be used in:

- Research on vehicle safety performance.

## How to obtain EDR data reading tool

Special technical equipment is required to read EDR data. For more information, please contact GAC Motor authorized shop.



### 2.1 Exterior

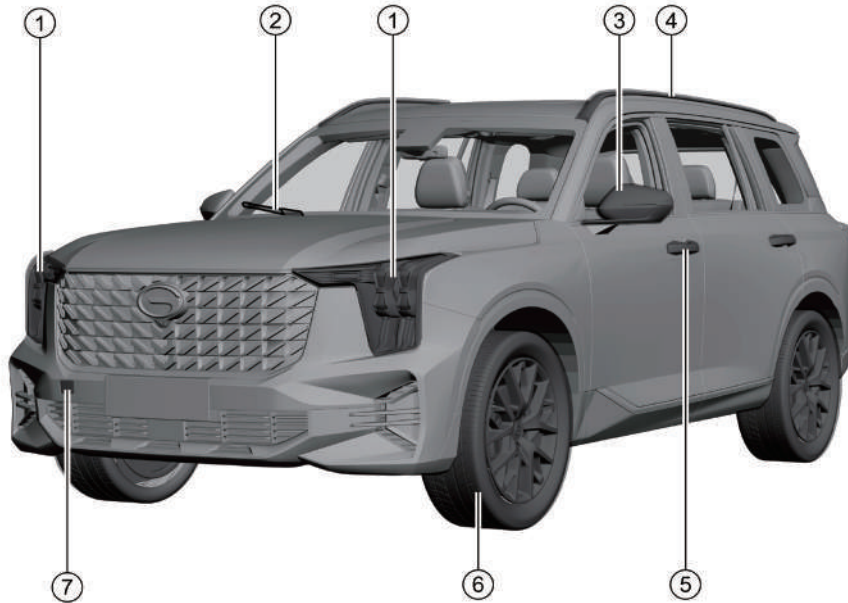

- ① Front combination lamp
  - Turning on lamps => [See page 75](#)
  - Replacing bulbs => [See page 265](#)
  - Specifications of front combination lamp bulbs => [See page 281](#)
- ② Front wiper
  - Replacing front windshield wiper blades => [See page 260](#)
- ③ Exterior rearview mirror
  - Side turn signal lamp => [See page 76](#)
  - Specifications of side turn signal lamp => [See page 281](#)
- ④ Luggage rack => [See page 107](#)
- ⑤ PEPS system => [See page 50](#)
  - Door lock hole => [See page 56](#)
- ⑥ Wheel => [See page 266](#)
- ⑦ Front towing => [See page 300](#)

## 2. Pictorial References

---

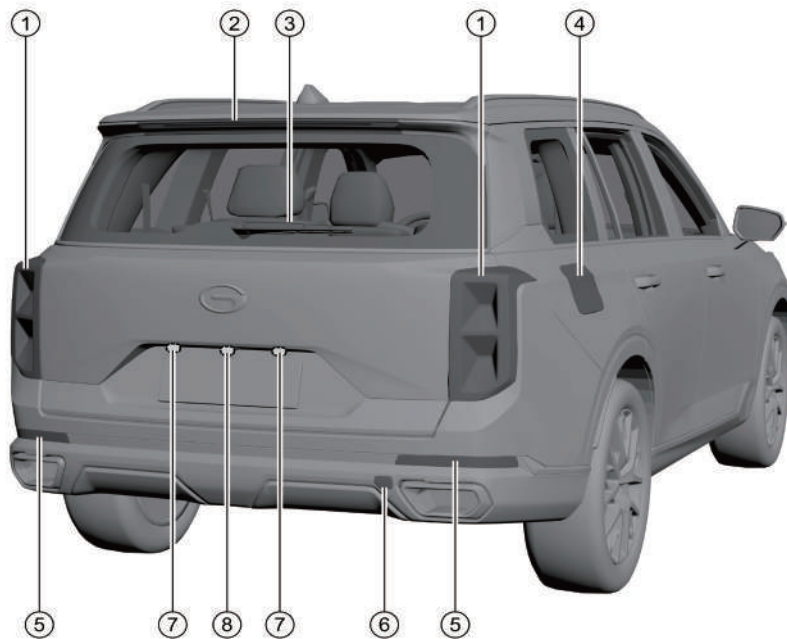

- ① Rear combination lamp
  - Specifications of rear combination lamp bulbs => [See page 281](#)
- ② High-mounted stop lamp
  - Specifications of high-mounted stop lamp => [See page 281](#)
- ③ Rear wiper
  - Replacing rear wiper blades => [See page 261](#)
- ④ Fuel tank cap => [See page 250](#)
- ⑤ Rear fog lamp
  - Specifications of rear fog lamp => [See page 281](#)
  - Specifications of reverse lamp => [See page 281](#)
- ⑥ Rear towing => [See page 300](#)
- ⑦ License plate lamp
  - Specifications of license plate lamp => [See page 281](#)
- ⑧ Liftgate unlocking button => [See page 61](#)

## 2. Pictorial References

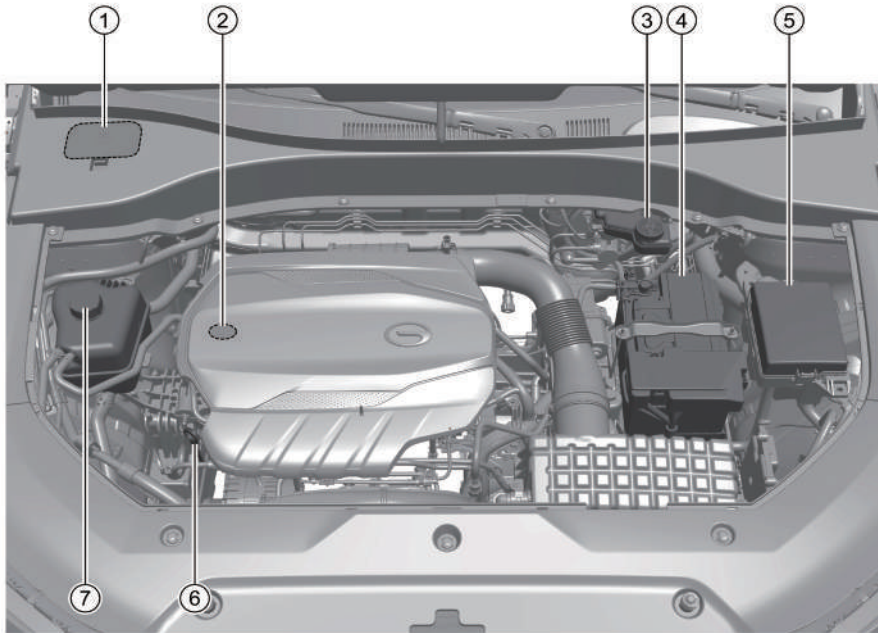

### Engine compartment

- ① Windshield washer fluid filler cap => See page 259
- ② Oil filler cap => See page 255
- ③ Brake fluid reservoir => See page 262
- ④ Battery => See page 263
- ⑤ Engine compartment power distribution unit => See page 295
- ⑥ Oil dipstick => See page 254
- ⑦ Expansion tank => See page 257

### CAUTION

The rear upper guard plate assembly of engine compartment has been removed in the figure.

## 2. Pictorial References

### 2.2 Interior

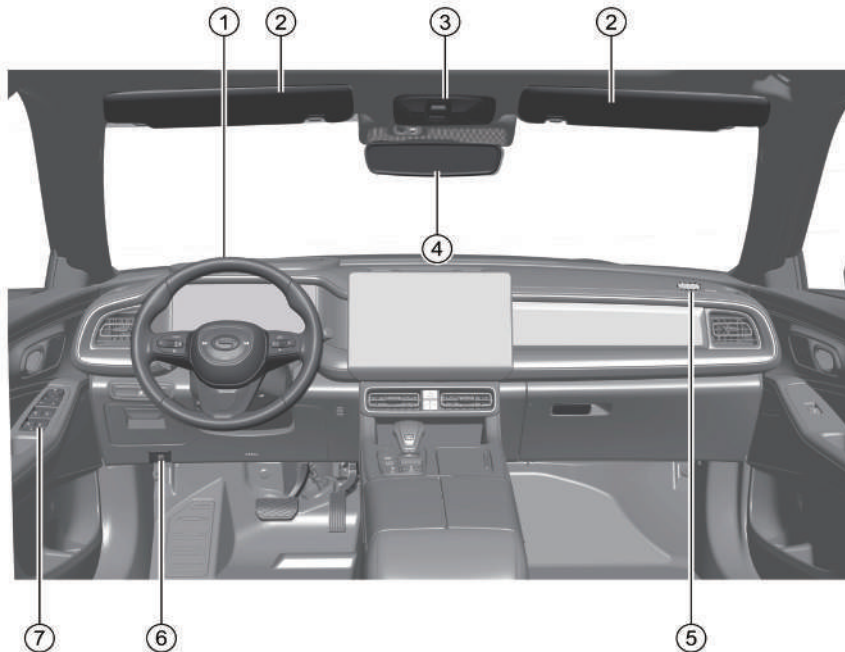

- ① Steering wheel => See page 37
  - Steering wheel buttons => See page 38
  - Driver's frontal airbag => See page 19
  - Paddle shifter\* => See page 145
- ② Sun visor => See page 90
- ③ Front dome lamp => See page 81
  - Power sunroof control button\* => See page 70
  - Electric sunshade control button\* => See page 69
  - SOS button\* => See page 138
  - Spectacle case => See page 99
- ④ Interior rearview mirror => See page 87
- ⑤ Front passenger's frontal airbag => See page 20
- ⑥ Driver's knee airbag \* => See page 21
- ⑦ Engine hood release handle => See page 66
- ⑧ Driver's power window control button => See page 67
  - Central locking button => See page 55
  - Exterior rearview mirror adjusting button => See page 88

## 2. Pictorial References

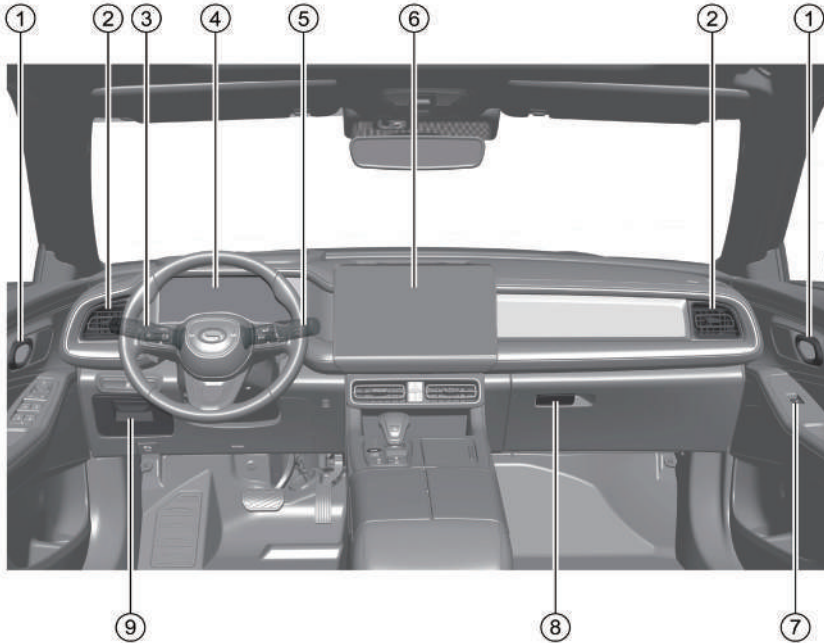

- ① Inside handle => See page 55
- ② A/C air outlet => See page 117
- ③ Lamplight combination switch => See page 75
- ④ Instrument cluster => See page 39
  - Indicator lamp => See page 46
- ⑤ Wiper combination switch => See page 85
- ⑥ AV system => See page 120
- ⑦ Passenger's power window control button => See page 68
- ⑧ Handle for opening the glove box => See page 101
- ⑨ Storage box on lower guard plate of cab => See page 98
  - Instrument panel PDU => See page 295

## 2. Pictorial References

---

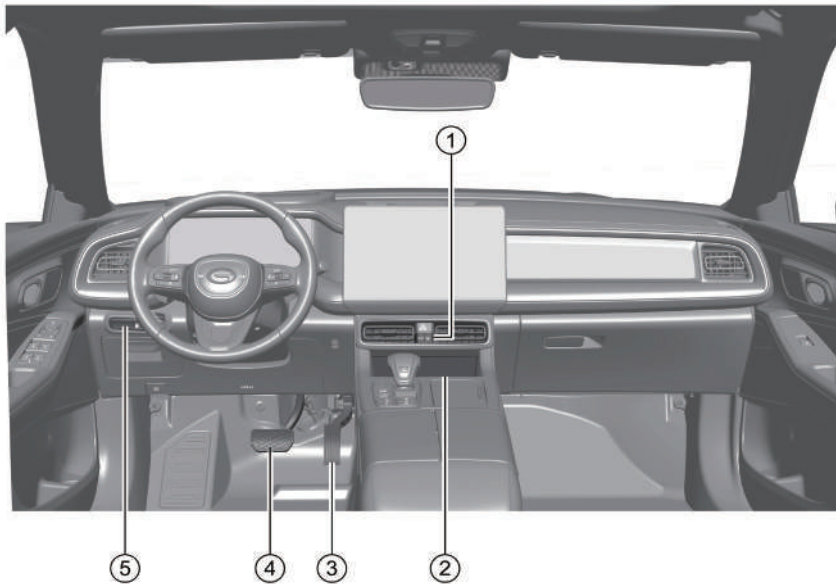

- ① A/C control button => See page 117
- Hazard warning lamp => See page 80
- ② Front storage compartment of instrument panel => See page 99
- Mobile phone wireless charging area\* => See page 103
- ③ Accelerator pedal
- ④ Brake pedal
- ⑤ Instrument panel left switch block
- Manual headlamp leveling knob\* => See page 79
- Liftgate button on the instrument panel => See page 62
- Fuel tank cap unlocking button => See page 250

## 2. Pictorial References

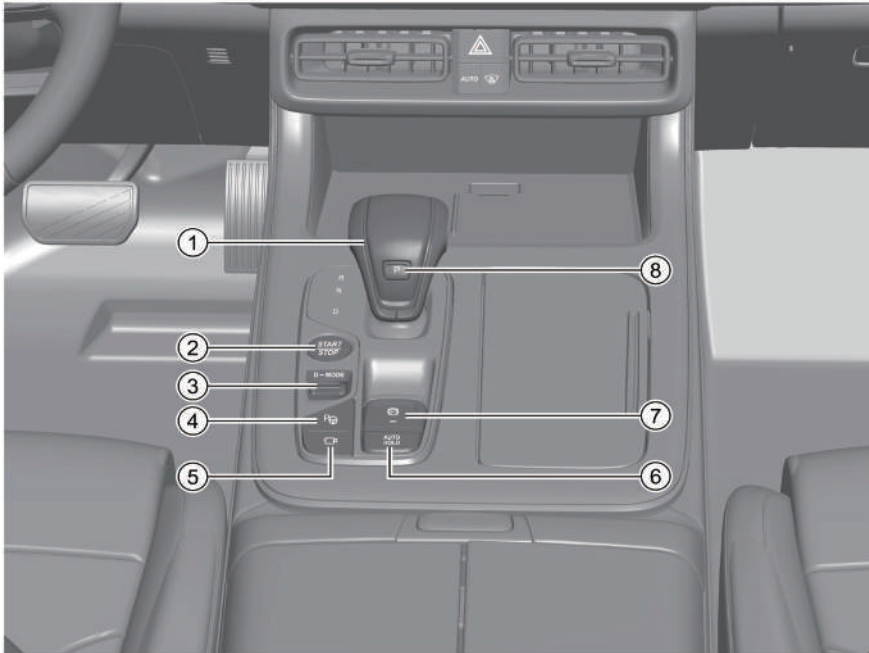

- ① Transmission gearshift lever => See page 142
- ② ENGINE START/STOP button => See page 139
- ③ Driving mode button => See page 144
- ④ APA button\* => See page 231
- ⑤ AVM button\* => See page 224
- ⑥ AUTO HOLD button => See page 151
- ⑦ EPB button => See page 148
- ⑧ "P" gear button => See page 142

## 3. Safety Operating Instructions

### 3.1 Safe driving

#### 3.1.1 General description

This section introduces important information, operating essentials, recommendations and safety precautions for safe driving. For the safety of you and the passengers, please read carefully and follow the relevant regulations.

#### NOTE

Please always keep the *Owner's Manual* in the vehicle. If you lend or resell the vehicle to someone else, be sure to hand the complete set of accompanying documents over to the new owner.

The following inspections must be carried out before driving:

- Check that all lamps are working properly.
- Check that the fuel level is normal.
- Check that the coolant level is normal.
- Check that the brake fluid level is normal.
- Check that the windshield washer fluid level is normal.
- Check that the tire pressure is normal.
- Check that the engine hood is closed and locked properly.
- Check that all windows are clear and have a good view.
- Check that no objects obstruct the movement of the driver's foot pedals.
- Adjust the seat, head restraint and rearview mirror according to your body height and shape.
- Use appropriate child safety seats to protect children and help them fasten the seat belts correctly.
- Fasten the seat belt correctly and remind all passengers in the vehicle to fasten the seat belts correctly.



#### WARNING

**When installing the driver's floor mat, please observe the following precautions:**

- Do not overlap two or more floor mats.
- Do not make the bottom surface of the floor mat upward or back-to-front.
- Do not use floor mats that are incompatible with this model.



#### CAUTION

- Do not distract yourself from external factors during driving.
- Do not drive the vehicle when your response capability decreases, such as due to medicines, alcohol, or drugs.
- Strictly abide by traffic regulations.



#### 3.1.2 Correct sitting posture of the driver and passengers

##### Correct sitting posture of the driver

The driver's sitting posture directly affects his/her fatigue level and driving safety. Before driving, the driver should:

- Sit up straight and adjust the seat back to a suitable position so that your back fits completely the seat back.
- Adjust the seat position so that all pedals can be operated effectively with slightly bent legs.
- Correctly adjust the headrest. => See page 91
- Fasten the seat belt correctly. => See page 16
- Adjust the steering wheel position. => See page 37

##### WARNING

**Do not adjust the seat, headrest or steering wheel during driving; otherwise the vehicle may be out of control, leading to an accident.**

##### Correct sitting posture of the passengers

To guarantee the safety of the passengers and reduce the risk of casualties, the passengers should:

- Sit up straight and adjust the head restraint of the seat correctly. => See page 91
- Adjust the distance between the seat and the instrument panel as demanded (for front passenger).
- Adjust the seat back until the back fits completely the seat back (for front passenger).
- Fasten the seat belt correctly. => See page 16
- Place both feet on the floor.
- Use appropriate child safety seat in accordance with applicable regulations for children. => See page 27

##### WARNING

- It is forbidden to install a child safety seat in the front passenger's seat.
- If the front passenger is too close to the instrument panel, the SRS will not provide effective protection.
- When the vehicle is running, be sure to maintain a correct sitting posture and fasten the seat belt correctly, so as to avoid unexpected injuries in case of emergency braking or accidents.

## 3. Safety Operating Instructions

### 3.2 Seat belt

#### 3.2.1 Why must you fasten the seat belt

Protection of the driver and passengers by seat belts



In the event of a vehicle collision, the seat belt, if fastened correctly, can restrain the driver and passengers in a proper position and slow down the inertia of their forward movement, thus preventing them from being thrown forward, and at the same time allow airbags to give them the best protection, thus reducing their impact injury as much as possible.

In the event of a collision, the seat belt will assist other safety systems in simultaneously absorbing the energy generated by the collision, further reducing the injuries suffered by the driver and passengers.



#### WARNING

**Airbags cannot replace seat belts. Regardless of whether the car is equipped with airbags, the seat belts should be worn correctly.**

#### Consequences of not fastening the seat belt

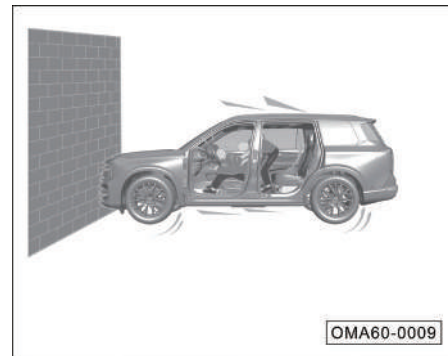

In the event of a collision, the driver or passenger who does not fasten the seat belt will be thrown forward due to inertia and thereby injured.

### 3. Safety Operating Instructions



Even if the vehicle speed is very low, the force acting on the human body in the event of a collision is so great that the occupant cannot control his or her body with hands at all. In that case, the occupant who does not fasten the seat belt will be thrown forward, and injured if colliding with any interior objects.



Rear passengers must also fasten the seat belts correctly, otherwise they will be thrown forward when an accident occurs. The occupant who does not fasten the seat belt will not only hurt himself or herself, but also endanger other occupants in the car.

## 3. Safety Operating Instructions

### 3.2.2 Seat belt

#### Seat belt indicator lamp

 : Driver's seat belt indicator lamp

 : Front passenger's seat belt indicator lamp

The following alarms will be triggered when the vehicle power switch is set to "ON" position:

- When the vehicle speed is lower than 20 km/h, if the driver or front passenger does not fasten the seat belt, the corresponding indicator lamp in the instrument cluster will flash for about 6 s and stay on.
- If the driver or front passenger does not fasten the seat belt at a speed higher than or equal to 20km/h, the corresponding indicator lamp in the instrument cluster will flash for about 20s and stay on, accompanied by an alarm message and a continuous audible alarm.

#### CAUTION

- Before driving, please check whether there are any heavy objects on the front passenger's seat to avoid the system mistakenly determining that the seat is occupied and issuing a false alarm.
- If the alarm remains on after the seat belt is fastened correctly, it means that the seat belt reminder fails. In that case, please contact the GAC Motor authorized shop for inspection in time.

#### WARNING

**Never insert the substitute of seat belt tongue into the buckle to eliminate the seat belt alarm.**

 : Rear seat belt indicator lamp

If rear seat belt indicator lamp is on in white, it indicates that the seat belt is fastened, and if the indicator lamp is on in red, it indicates that the seat belt is not fastened or the seat belt system is faulty. If the indicator lamp stays red after the seat belt is fastened correctly, it means that the SRS is failed. In that case, please go to the GAC Motor authorized shop for inspection in time.

The rear seat belt indicator lamp is on for 65 s and then goes out in normal cases, and it will light up under the following conditions:

- The rear passenger does not fasten the seat belt when the engine starts.
- The rear passenger does not fasten the seat belt when the rear door is opened/closed.
- The rear passenger fastens or unfastens the seat belt.

#### NOTE

This function can be activated or deactivated via "Settings → Display Setup → Instrument → Rear Seat Belt Reminder" in the AV system.

### 3. Safety Operating Instructions

#### Seat belt pretensioner and load limiter \*



The seat belt pretensioner and load limiter can reduce the pressure of the seat belt on the chest of the driver or passenger and improve the protection performance.

- Before the collision, the seat belt pretensioner and load limiter can restrain the driver or passenger and enable him or her to maintain a correct sitting posture to prevent the body from leaning forward.
- In the event of a severe collision where the triggering condition is reached, the seat belt pretensioner and load limiter will be triggered, driving the seat belt webbing to be quickly retracted and tensioned.

- When a vehicle collision occurs, the human body will move forward, and the seat belt load limiter will be activated at this time, so that the restraint force of the seat belt on the human body will be within a certain range, preventing the occupant from being further injured due to excessive force. And at the same time, the seat belt pretensioner and load limiter will work with the airbag to achieve a better safety protection performance.

#### i NOTE

- When the seat belt pretensioner and load limiter is activated, a little harmless smoke together with a sound will be produced, which is normal.
- The seat belt pretensioner and load limiter cannot be used any more if deployed, and in this case, the SRS indicator lamp  stays on, please contact the GAC Motor authorized shop for replacement.

#### Adjusting the front shoulder belt height

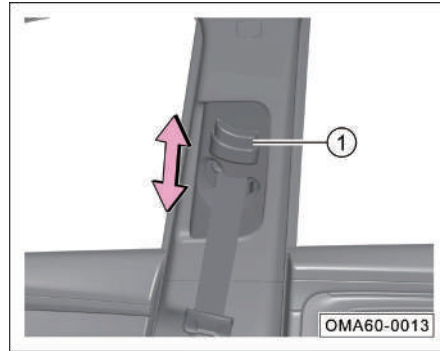

- Moving up: Grasp the guide and move it up to adjust the shoulder belt to the appropriate height.
- Moving down: Press the guide to unlock the switch ① and move it down to adjust the shoulder belt to the appropriate height.
- After the adjustment, move the guide down to check whether it is firmly locked.

### 3. Safety Operating Instructions

#### Fastening the front seat belt

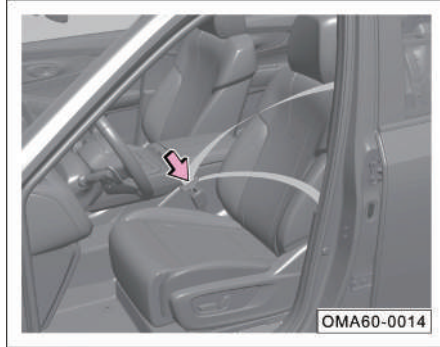

- Keep a correct sitting posture. => See page 11
- Pull out the seat belt slowly at a uniform speed, and insert the tongue into the corresponding buckle until a click is heard.
- Pull the seat belt and confirm that the tongue is properly locked.

#### **i** NOTE

Outboard rear seat belts are fastened in the same way, and the driver is responsible for reminding passengers to fasten the seat belts correctly.

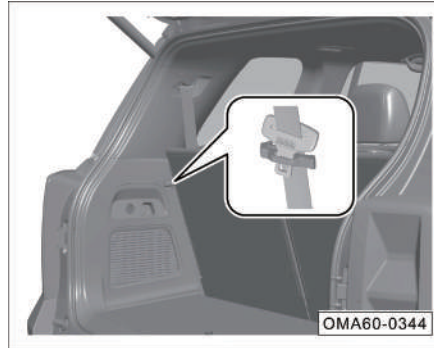

When fastening the outboard rear seat belts, pull out the belt tongue from the trim panel clamp, then slide the seat belt webbing out from the clamp, pull the seat belt and fasten it, taking care not to damage the clamp.

#### Unfastening the seat belt



- Press the red button of the buckle. Then the lock tongue will pop out automatically.
- Grasp the seat belt to allow it to retract slowly.

#### Pregnant women must fasten the seat belts correctly



How does a pregnant woman correctly fasten the seat belt?

- Adjust the seat and head restraint to the proper position.
- Grasp the lock tongue, slowly pull the seat belt over the shoulder, and ensure that the lap belt is as low as possible and not pressed against the abdomen.
- Insert the lock tongue into the corresponding buckle until a buckling sound is heard.
- Pull the shoulder belt upward parallel to the upper body, tension the lap belt, and make sure that the lock tongue is properly locked.

#### WARNING

To reduce the risk of injury during emergency braking or accidents, please observe the following precautions:

- Before driving, make sure that all occupants have properly fastened the seat belts.
- Each seat belt is for one person only. Do not share a seat belt with other persons (including children).
- Do not recline the front seat back excessively for comfort.
- Do not put the shoulder belt under or behind your arm.
- Do not put the shoulder belt under or behind your arm.
- Be sure to insert the lock tongue into the buckle of corresponding side instead of the buckle of other side.

## 3. Safety Operating Instructions

### 3.3 Supplemental restraint system (SRS)

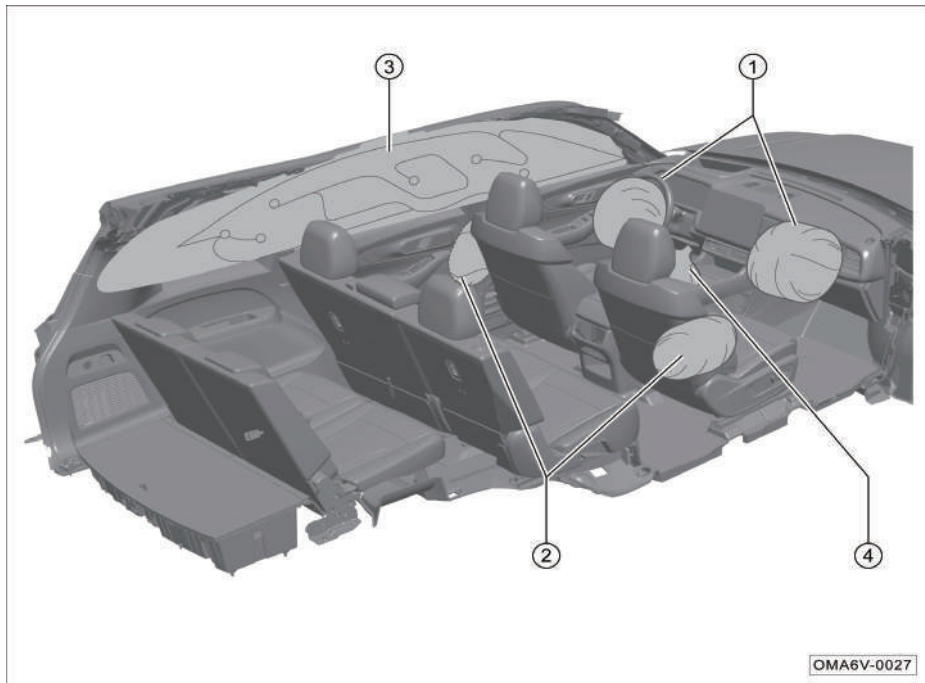

Depending on vehicle configurations, the deployment positions of the SRS are as shown below:

- ① Front seat frontal airbags.
- ② Front seat side airbags.
- ③ Side curtain airbags.
- ④ Driver's knee airbag \*.

#### **i** NOTE

The airbag will produce a little harmless smoke when deployed, which is normal.



#### Supplemental restraint system (SRS) indicator lamp

With the vehicle power switch set to “ON” position, the indicator lamp  will be on for a few seconds and go out after the system completes self-test.

A system fault is indicated when the indicator lamp  is in the following conditions:

1. The indicator lamp does not come on after the vehicle power switch is set to “ON” position.
2. With the vehicle power switch set to “ON” position, the indicator lamp does not go out after the system completes self-test.
3. After the vehicle power switch is set to “ON” position, the indicator lamp goes out but then comes on again.
4. The indicator lamp comes on or flashes while the vehicle is running.

#### WARNING

- **Never attempt to repair, adjust or modify the airbag.**
- **The airbag can be deployed once only, and thus, if it is deployed in an accident, please contact the GAC Motor authorized shop for replacement.**
- **When the SRS is faulty, please contact the GAC Motor authorized shop for inspection. Otherwise, the system cannot trigger or abnormally triggers the airbag in the event of a vehicle collision.**

#### Front seat frontal airbag

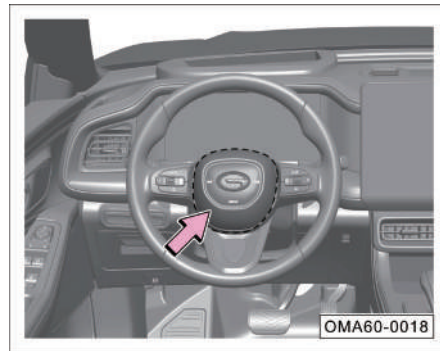

The driver's frontal airbag is installed inside the steering wheel (as indicated by the dotted dash) marked with “AIRBAG”.

### 3. Safety Operating Instructions

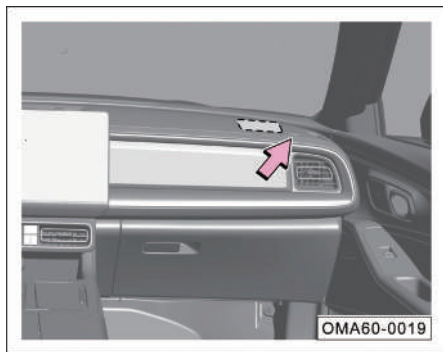

The front passenger's frontal airbag is installed inside the instrument panel (as indicated by the dotted dash) marked with "AIRBAG".

In the event of a frontal collision which is severe enough to meet the triggering condition of frontal airbag, the frontal airbags will be triggered by the system and deploy rapidly to assist the seat belt in protecting the driver and front passenger.

In certain collision accidents, the system may simultaneously trigger other airbags.

#### **WARNING**

**Do not attach or place any decorative objects on the surface of instrument panel, because when the vehicle is running or the airbag deploys, these objects will fall, be knocked over and roll around in the vehicle, affecting the driver and hurting the passengers in the vehicle.**

The front seat frontal airbags might not be triggered in the following cases:

- The vehicle power switch set to "ACC" or "OFF" position.
- Minor frontal collision.
- Side collision.
- Rear-end collision.
- Rollover.
- Other special circumstances.

#### **NOTE**

The word "minor" refers to the extent with respect to the car SRS controller and has nothing to do with the damage of the car.

### 3. Safety Operating Instructions

#### Driver's knee airbag \*

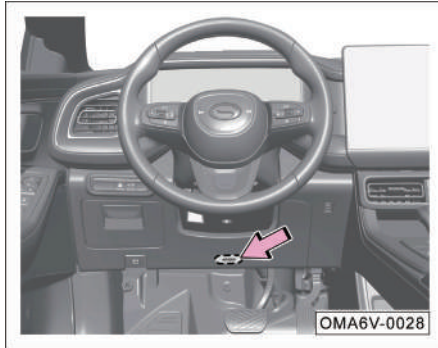

The driver's knee airbag is installed inside the instrument panel (as indicated by the dotted dash) marked with "AIRBAG".

In the event of a frontal collision which is severe enough to meet the triggering condition of driver's knee airbag, the driver's knee airbag will be triggered by the system and deploy rapidly to assist the seat belt in protecting the driver.

In certain collision accidents, the system may simultaneously trigger other airbags.

#### WARNING

**Do not attach or place any decorative objects on the surface of instrument panel, because when the vehicle is running or the airbag deploys, these objects will fall, be knocked over and roll around in the vehicle, affecting the driver and hurting the passengers in the vehicle.**

The driver's knee airbag might not be triggered in the following cases:

- The vehicle power switch set to "ACC" or "OFF" position.
- Minor frontal collision.
- Side collision.
- Rear-end collision.
- Rollover.
- Other special circumstances.

#### Front seat side airbag



The front seat side airbags are installed in the outboard sides of the driver's seat back and the front passenger's seat back respectively (as indicated by the dotted dash) marked with "AIRBAG".

### 3. Safety Operating Instructions

In the event of a side collision which is severe enough to meet the triggering condition of frontal airbag, the side airbags will be triggered by the system and deploy rapidly to assist the seat belt in protecting the driver and front passenger.

In certain collision accidents, the system may simultaneously trigger other airbags.

The front seat side airbags might not be triggered in the following cases:

- The vehicle power switch set to “ACC” or “OFF” position.
- 100% frontal collision.
- Minor side collision.
- Rear-end collision.
- Other special circumstances.

#### **i** NOTE

The word “minor” refers to the extent with respect to the car SRS controller and has nothing to do with the damage of the car.



#### **⚠** WARNING

- **Observe the instructions on the warning label pasted on the side of the door. Do not lean your body against the door side equipped with side airbags during driving.**
- **Do not cover the side airbags with seat covers or other objects; otherwise, the side airbags will not be deployed to protect the occupants when an accident occurs.**

#### Side curtain airbag

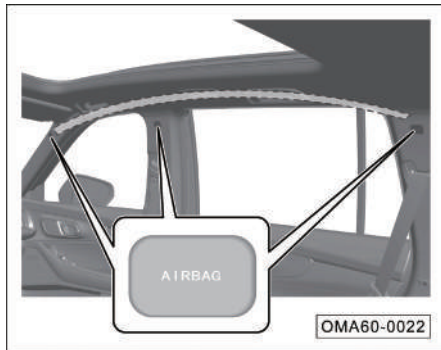

Side curtain airbags are installed in the left and right sides of the roof respectively (as indicated by the dotted dash), marked with "AIRBAG".

In the event of a side collision which is severe enough to meet the triggering condition of side curtain airbag, the curtain airbag on the side where the collision occurs will be triggered by the system and deploy rapidly to assist the seat belt in protecting the driver and front passenger.

In certain collision accidents, the system may simultaneously trigger other airbags.

The side curtain airbags might not be triggered in the following cases:

- The vehicle power switch set to "ACC" or "OFF" position.
- 100% frontal collision.
- Minor side collision.
- Rear-end collision.
- Other special circumstances.

#### **i** NOTE

The word "minor" refers to the extent with respect to the car SRS controller and has nothing to do with the damage of the car.

### 3. Safety Operating Instructions

---

#### 3.3.1 Cases where the airbags may deploy

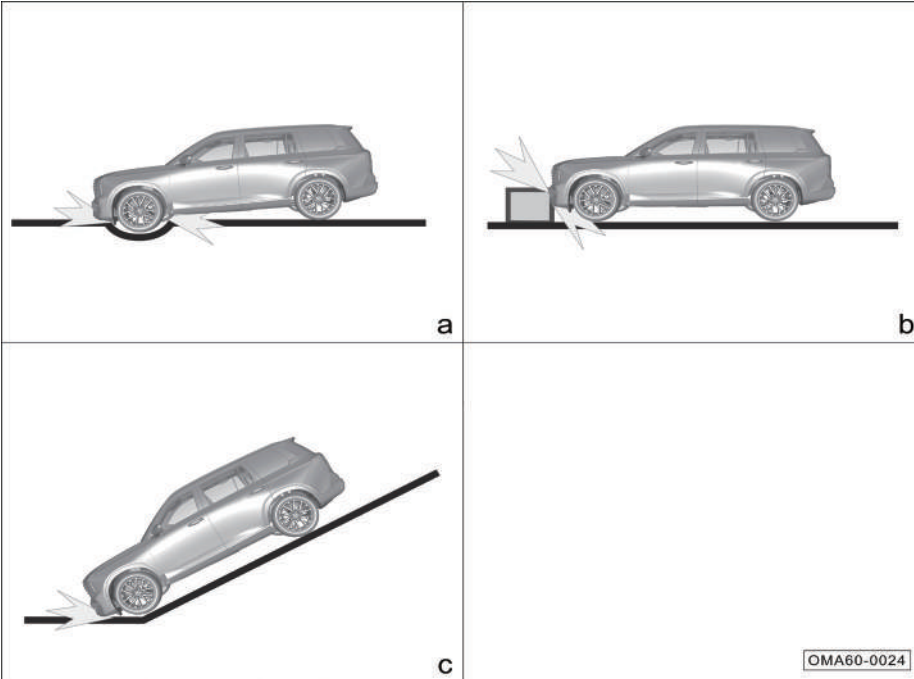

- a: Nose-down to the ground when the vehicle crosses a deep groove.
- b: Collision with roadside protrusions, curbs, etc.
- c: Nose-down to the ground when the vehicle runs down a steep slope.

### 3. Safety Operating Instructions

#### 3.3.2 Cases where the airbags might not deploy

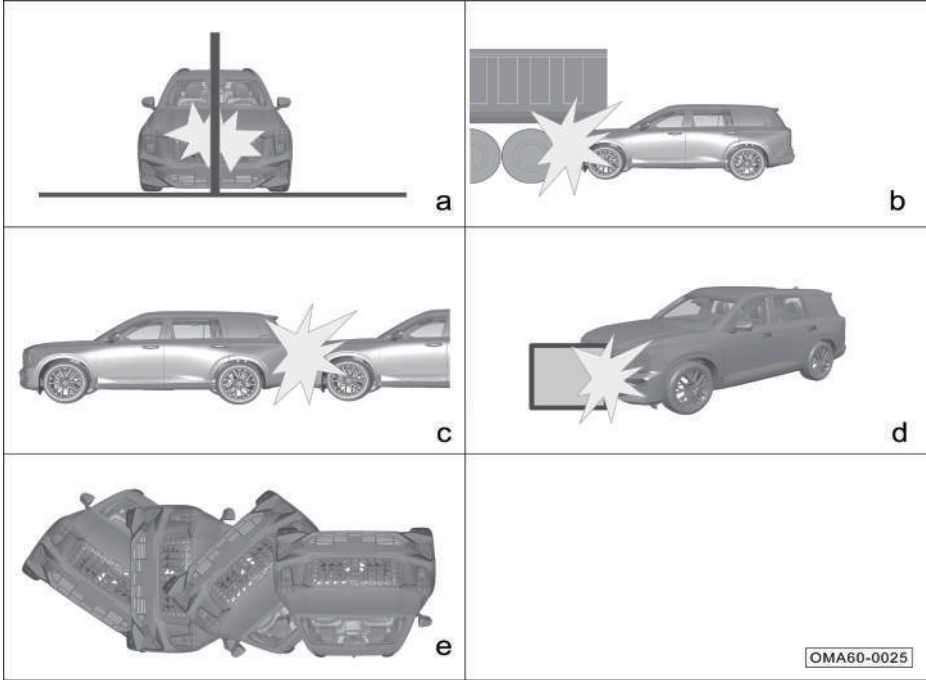

- a: Collision with concrete pillars, trees or other elongated objects.
- b: Rear-end collision with the lower rear end of large truck.
- c: Rear-end collision by other vehicles.
- d: Collision with a wall or another vehicle, other than frontal collision.
- e: Rollover.

## 3. Safety Operating Instructions

### 3.4 Safe ride of children

#### 3.4.1 General description

The child must sit in a rear seat (2nd row), and a suitable child safety seat should be selected for protection according to the body size of the child.



Warning labels are pasted on the front and back of the right sun visor to remind the front passenger of the danger of frontal airbag. Be sure to read and follow the instructions on the labels.

#### ⚠ WARNING

- Do not install any rear-facing child restraint system on seats with frontal airbags!
- Even if the child has been put in a child safety seat, do not let its head or any other part of the body rest on the door area (the deployment area of the front seat side airbag or side curtain airbag); otherwise the impact force of the deployed front seat side airbag or side curtain airbag can cause serious injury or even death of the child.
- Do not let children stand or kneel on the seat.
- Do not allow children to operate devices that may cause pinch to themselves (such as power window, sunroof, etc.).

#### ⚠ WARNING

- Never leave children alone in the vehicle!
- Never hold infants or toddlers on your knees!
- Seat belts are not suitable for infants and toddlers as they can cause injuries in the event of an accident.
- Ensure that in the event of a collision or emergency braking, children are less likely to be injured by hitting any hard objects in the vehicle.
- Lock the child safety lock of the door on the side where the child sits.



### 3. Safety Operating Instructions

#### 3.4.2 Child safety seat



a. Group 0/0+ child safety seat



b. Group I child safety seat



c. Group II child safety seat



d. Group III child safety seat

OMA60-0027

**Classification of child safety seats (for reference only):**

**a. Group 0/0+ child safety seat:**

- Suitable for infants weighing less than 13 kg.

**b. Group I child safety seat:**

- Suitable for toddlers weighing between 9kg and 18kg. For children weighing up to 18 kg (3 years old), rear-facing child safety seats must be installed.

**c. Group II child safety seat:**

- Suitable for children weighing between 15 kg and 25 kg.

**d. Group III child safety seat:**

- Suitable for children weighing between 22kg and 36kg.

### 3. Safety Operating Instructions

---

For the sake of safety, please adjust the rear seat (2nd row) with child safety seat to the rearmost position. Following models are recommended for Group I child safety seats:

1. Baby First Space Castle -Z, product model: R102C.
  - Rear-facing child safety seats with cushioned inserts are recommended. Adjust the cushioned inserts to the extent that the headrest is flush with the head of child. For specific installation method, please refer to the child safety seat instructions.
2. Weldon Angela 2nd Generation, product model: WD002-ZJC.

Precautions for installation:

  - Adjustment of seat body: Rear-facing seat is recommended. Adjust the seat body to make it upright.
  - Adjustment of headrest: It is recommended that the headrest be flush with the shoulder of the child.
  - It is recommended that the top tether hook be fixed to the rear seat back (2nd row).
  - It is recommended that clip gasket and shoulder belt jacket be used.

### 3.4.3 Information about child safety seat

Information about the applicability of different seating positions for child restraint systems:

Weight group	Mounting position			
	Front passenger's seat	Outboard 2nd-row seats	2nd-row center seat	Outboard 3rd-row seats
Group 0: <10 kg	X	U	X	X
Group 0+: <13 kg	X	U	X	X
Group I: 9~18 kg	X	U/UF/L	X	X
Group II: 15~25 kg	X	UF	X	X
Group III: 22~36 kg	X	UF	X	X

Note: The uppercase letters in the table are defined as follows:

U= The "general" child restraint systems approved for this weight group are suitable.

UF= The forward-facing "general" child restraint systems approved for this weight group are suitable.

L= The listed special child restraint systems are suitable, which may be for special vehicles, or of restricted or semi-general categories.

X= The child restraint systems approved for this weight group are not suitable.

For some child safety seats, a size class is specified. Be sure to check the size class according to the manufacturer's instructions, packaging, and child safety seat label. For guidance on proper installation, please refer to the instruction of the child safety seat.

The 3rd-row seats do not allow for any child safety seats.

### 3. Safety Operating Instructions

#### ISOFIX mounting positions for ISOFIX child safety seats

Weight group	Size class	Fixture module	Mounting position			
			Front passenger's seat	Outboard 2nd-row seats	2nd-row center seat	Outboard 3rd-row seats
Carry-cot	F	ISO/L1	X	X	X	X
Group 0: <10 kg	G	ISO/L2	X	X	X	X
	E	ISO/R1	X	IL	X	X
Group 0+: <13 kg	E	ISO/R1	X	IL	X	X
	D	ISO/R2	X	IL	X	X
	C	ISO/R3	X	IL	X	X
Group I: 9~18 kg	D	ISO/R2	X	IL	X	X
	C	ISO/R3	X	IL	X	X
	B	ISO/F2	X	IUF	X	X
	B1	ISO/F2X	X	IL	X	X
	A	ISO/F3	X	IUF	X	X
Group II: 15~25 kg	-	-	X	IUF	X	X
Group III: 22~36 kg	-	-	X	IUF	X	X

Note: The uppercase letters in the table are defined as follows:

IUF - The "forward-facing" general ISOFIX child safety seats for this weight group that are fixed with top tether are suitable.

IL - The listed special ISOFIX child restraint systems are suitable, which may be for special vehicles, or of restricted or semi-general categories.

X - The child safety seats for this weight group are not suitable.

For some child safety seats, a size class is specified. Be sure to check the size class according to the manufacturer's instructions, packaging, and child safety seat label. For guidance on proper installation, please refer to the instruction of the child safety seat.

The 3rd-row seats do not allow for any child safety seats.

#### 3.4.4 Correct installation of child safety seat

The child safety seat is installed by three-point seat belt, ISOFIX system, or LATCH system.

To ensure a better protection effect and prevent the headrest from affecting the performance of the child safety seat during use, it is recommended to remove the headrest of the seat on which the child safety seat is installed.

#### **i** NOTE

- During the actual installation of the child safety seat, be sure to refer to the instruction of the child safety seat for correct installation.
- For the sake of safety, please adjust the rear seat (2nd row) with child safety seat to the rearmost position.

#### Installation of child safety seat by three-point seat belt



1. Place the child safety seat on the rear seat (2nd row).
2. Pass the seat belt through the child safety seat and fully insert the tongue into the buckle until a click sound is heard.

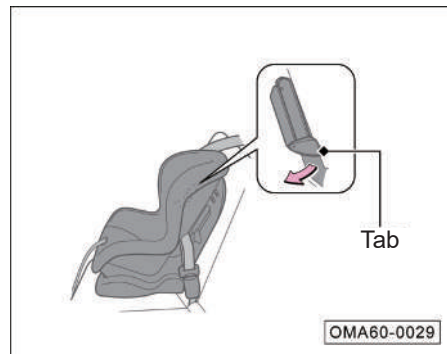

3. Push the tongue down and pass the shoulder belt through the slit on the side of the child safety seat.

### 3. Safety Operating Instructions

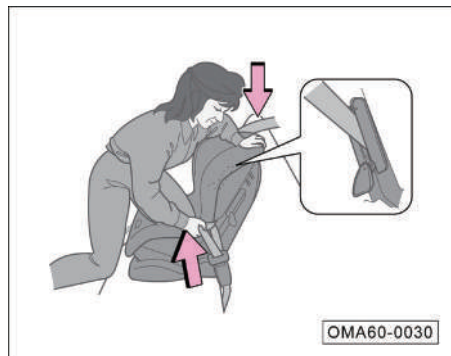

4. Grasp the shoulder belt near the buckle and pull it up to tension the lap belt. At this time, press the child safety seat with your own weight and push it into the vehicle seat.

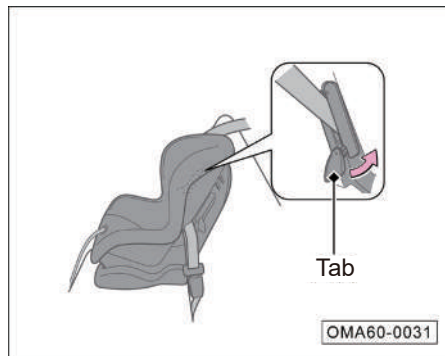

5. Place the seat belt correctly and push the tab up. Make sure the seat belt is not twisted. When pushing the tab up, pull upward the upper part of the shoulder belt to tension the belt.



6. Shake the child safety seat back and forth, left and right to make sure it is firmly fixed.
7. Make sure that all unused seat belts in the reach of the children are locked.

### 3. Safety Operating Instructions

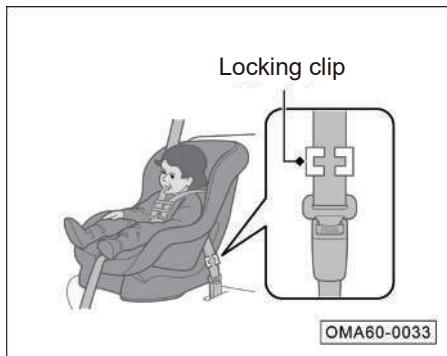

If no means are provided on the child safety seat for securing the seat belt, please install a locking clip on the seat belt.

- After the above steps 1 and 2, pull up the shoulder belt and make sure the lap belt is tensioned.
- Firmly grasp the seat belt near the tongue. Pinch the two parts of the seat belt together so that they do not slip out of the tongue. Unbuckle the seat belt.

Install the locking clip as shown. Place the buckle as close as possible to the locking tab and insert the locking tab into the locking clip. Go to steps 6 and 7.

#### Installing LATCH or ISOFIX system

The rear seats (2nd-row) of this vehicle are equipped with the LATCH system, and thus suitable for the LATCH or ISOFIX child safety seats. The installation instructions of the LATCH child safety seat are as follows.

#### ⚠ WARNING

- **The child safety seat anchorages installed in this vehicle can be used to fix the child safety seats only.**
- **Do not connect straps, hard and sharp objects or any other objects other than child safety seats to the anchorages; otherwise, children may be endangered in the event of an accident.**

#### 2nd-row seats

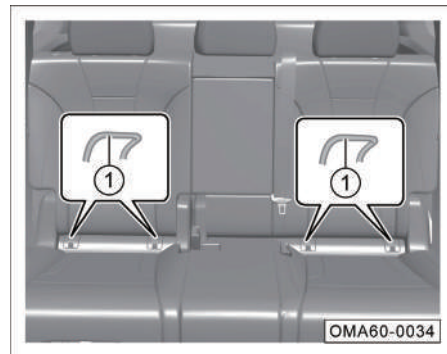

Open the cover, then you can see the front anchorage ① on the 2nd-row seat.

### 3. Safety Operating Instructions

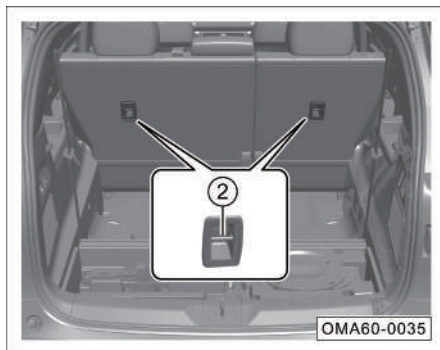

#### **i** NOTE

The rear anchorage ② on the 2nd-row seat is located in the middle of backside of the seat back, and can be seen after opening the protective cover.

The installation instructions of the LATCH child safety seat are as follows.

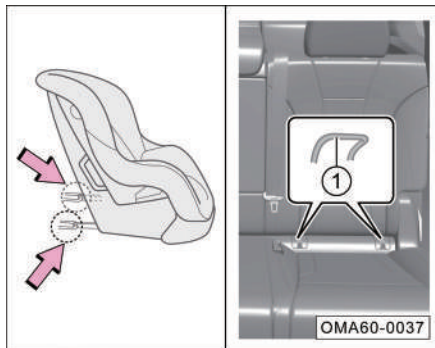

1. Put the child safety seat on the seat, open the cover and find the front anchorage ①. Then insert the lower guide groove of the child safety seat as arrowed into the front anchorage ① until a click is heard.

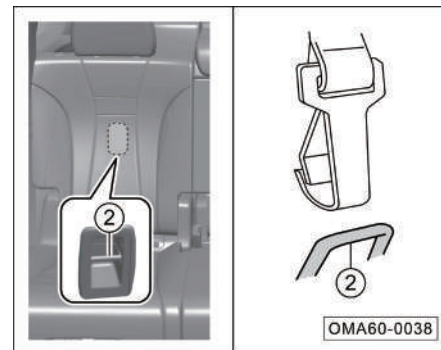

2. Thread the strap through the top of seat back, open the protective cover of rear anchorage ②, and attach the strap hook to the rear anchorage ② with the strap not twisted.
3. Tension the strap and shake the child safety seat to ensure it is firmly fixed.



#### 3.5 Exhaust gas hazard

##### Carbon monoxide

The exhaust gas emitted by the engine contains the toxic carbon monoxide gas. Please use the vehicle correctly to prevent the carbon monoxide gas from entering the vehicle.

Please contact the GAC Motor authorized shop to check whether the exhaust system is normal in the following cases:

- The exhaust system makes abnormal noises.

The exhaust color is abnormal.

If the engine is idling during parking, please open all the windows and turn on the A/C system:

1. Select the fresh air mode.
2. Select  mode.
3. Set the fan speed to the maximum.

#### WARNING

- **Carbon monoxide is toxic, and inhaling a great quantity of it will cause loss of consciousness and even death.**
- **When the engine is started for a long time in a confined space (such as a garage, etc.), carbon monoxide will quickly accumulate, resulting in excessive carbon monoxide in the vehicle. After starting the engine, drive the vehicle away from the confined space immediately.**

### 3. Safety Operating Instructions

#### 3.6 Safety label

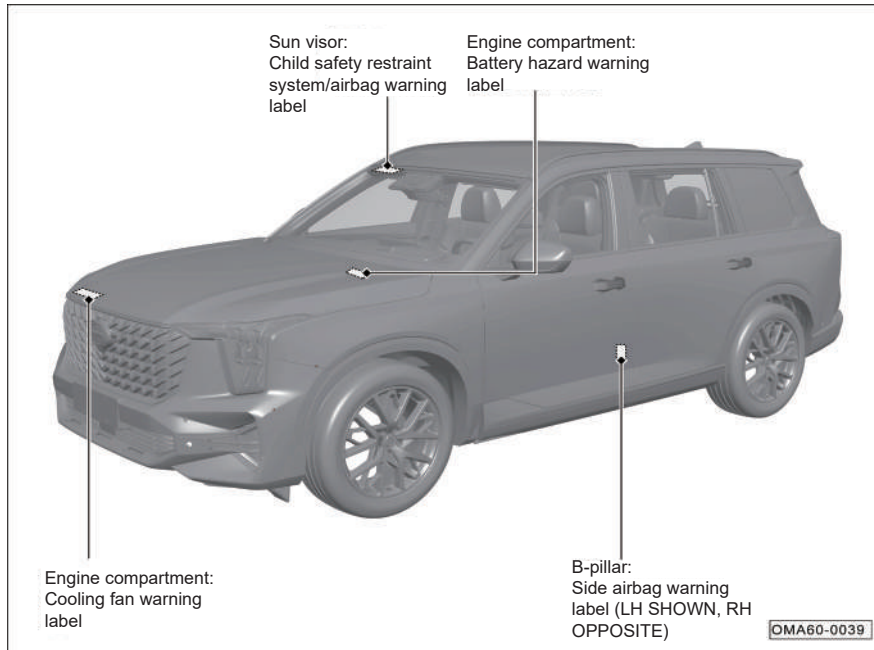

The labels are located as shown to remind you of the potential danger that can cause serious injury or death. Please read these labels carefully.

If the label comes off or is difficult to read, please go to the GAC Motor authorized shop in time for replacement.

#### **i** NOTE

In case of any discrepancy in the illustrated location or quantity of the labels, the actual vehicle shall prevail.

### 4.1 Cab

#### 4.1.1 Steering wheel

##### Adjustment of the steering wheel position



- Adjust the driver's seat until your chest is at least 25mm away from the steering wheel.

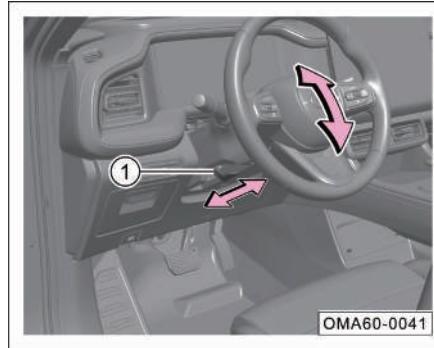

- Push down the locking handle ① to unlock the steering wheel.
- Adjust the steering wheel to the appropriate position up, down, front, and back as required, so that you can see the instrument panel and all indicator lamps.
- Pull up the locking handle ① to lock the steering wheel and make sure it is firmly locked.

#### WARNING

- During driving, the driver's hands should always grasp the outer ring of the steering wheel (9 o'clock and 3 o'clock positions).
- After adjustment, the steering wheel must be locked to prevent shifting while the vehicle is running.
- Only when the vehicle is stopped can the steering wheel be adjusted to avoid traffic accidents.
- To ensure safety, the steering wheel should face your chest, otherwise the airbag cannot provide effective protection in the event of an accident.

## 4. Operation of systems and equipment

### Buttons on steering wheel



- ① The left buttons include the control buttons of the instrument cluster display and the cruise control buttons:
- Control buttons of the instrument cluster display:
  - Driving information => See page 41
  - Alarm center => See page 44
  - Theme of instrument panel => See page 41

- Cruise control button:
  - Cruise control buttons\* => See page 158
  - ACC button\* => See page 160
- ② Horn button: Press  button to sound the horn; release the button to stop sounding the horn.

#### WARNING

**Do not press and hold  button for a long time; otherwise, the horn is highly prone to be damaged.**

- ③ The right buttons include the control buttons of AV system:
- Control buttons of AV system => See page 120

## 4. Operation of systems and equipment

### 4.1.2 Instrument cluster

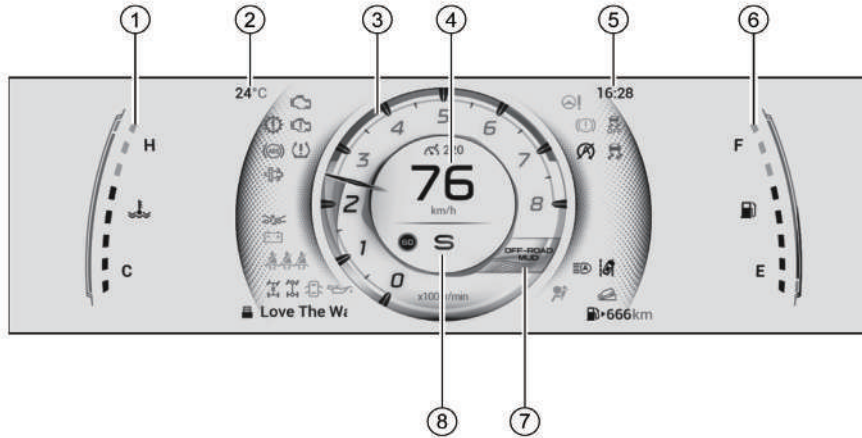

OMA60-6050

#### Instrument cluster (Sport theme)

- ① Engine coolant temperature gauge
- ② Outside temperature indication
- ③ Tachometer
- ④ Speedometer
- ⑤ Time display
- ⑥ Fuel gauge
- ⑦ Driving mode
- ⑧ Gear display

#### **i** NOTE

- The instrument cluster shows different colors corresponding to the switched driving modes.
- The instrument cluster allows for multiple themes, including “Sport theme”, “AVDC theme” and “Intelligent driving theme”. The AVDC theme is illustrated here and for reference only. Please refer to the actual vehicle.

## 4. Operation of systems and equipment

### Tachometer

The tachometer is used to indicate the current engine speed, in 1,000 r/min.

#### CAUTION

The area of 6000~8000 r/min represents the high load area of the vehicle. Avoid running the vehicle with the pointer of the tachometer within this area; otherwise, fuel shut-off and loss of power will occur due to self-protection of the engine.

### Speedometer

The speedometer indicates the current speed of the vehicle in km/h, in the range of 0~240 km/h.

#### WARNING

**For driving safety, please strictly abide by the traffic rules, and never speed the vehicle.**

### Engine coolant temperature gauge

The engine coolant temperature gauge is used to indicate the current temperature of the engine coolant.

- The indication range covers C~H, where, “C” means low temperature and “H” means high temperature.

After the engine is started, the corresponding scale divisions of the coolant temperature gauge will be illuminated according to different temperatures, and the engine operating temperature will vary depending on the ambient temperature and engine load.

- Conditions where the gauge indicates high coolant temperature: prolonged climbing in hot weather; deceleration or stop after driving at a high speed; in areas with heavy traffic, where the HVAC system is turned on and the engine idles for a long time; towing, etc.
- Conditions where the gauge indicates low coolant temperature: insufficient warm-up after cold start in cold weather; running with maximum heating in cold weather, etc.

### Fuel gauge

The fuel gauge is used to indicate the current amount of fuel remaining in the fuel tank.

- The indication range is E~F, where “E” means the fuel tank is empty, and “F” means the fuel tank is full. The corresponding scale divisions are illuminated according to the remaining fuel in the fuel tank.
- When no scale division is illuminated or only the first scale division is illuminated, it means that the fuel in the fuel tank is insufficient. In that case, the yellow indicator lamp  on the instrument cluster will flash, accompanied by the alarm message “Low fuel level”, reminding the driver that there is not enough fuel and fuel should be added as soon as possible.

### Gear display

- The current gear information of the vehicle such as “P”, “R”, “N” or “D” is displayed according to the received signal.

### Driving mode

- The current driving mode of the vehicle is displayed according to the received signal.

### Outside temperature indication

- The current outside temperature is displayed on the screen.

## 4. Operation of systems and equipment

### Odometer

- The odometer indicates the traveled distance of the vehicle in the driving information screen.
- The indication range is 0~999999 km.
- The odometer is only displayed when the Sport theme is switched through the steering wheel.

### Instrument cluster display

The displayed information includes: Driving information, vehicle state, G value graph, throttle sensitivity, fuel consumption trend, ADAS, alarm center.

#### CAUTION

If the instrument cluster display is abnormal (such as black/white screen, flickering/dots), stop the vehicle immediately for the sake of safety, and contact the GAC Motor authorized shop for inspection.

### Theme setting of instrument panel



With vehicle power switch set to “ON” position, press “VIEW” button on the left of steering wheel to access the screen of theme setting of instrument panel.

- When “ACC” function is not activated, pressing “VIEW” button can achieve free switching among the Sport theme and the AVDC theme of the instrument panel only; only when the ACC/ICA is activated can automatic jump to the Intelligent driving theme of the instrument panel be achieved.
- After “ACC” function is activated, the intelligent driving theme of the instrument panel will remain on.

### Driving information

Cumulative driving	Current driving
Traveled distance 999km Average fuel consumption 20.0L/100km Driving time 360:30h Odometer 100000km	Traveled distance 999.2km Average fuel consumption 20.0L/100km Driving time 360:30h
(Reset by pressing and holding OK button)	

OMA60-6027

When the vehicle power switch is set to “ON” position, move up or down the “OK” button on the left of the steering wheel to switch to the driving information screen.

- The driving information screen displays: Current trip, odometer.
- Current trip: It indicates the driving information (trip distance/ average fuel consumption/ driving time) of the vehicle in a single trip after the ENGINE START/ STOP button is set to “ON” position, which will be reset every time the engine is turned off.

## 4. Operation of systems and equipment

- Cumulative driving: It indicates the driving information (cumulative distance/ average fuel consumption/ driving time) of the vehicle since the last reset, where the vehicle parameters can be reset by pressing and holding “OK” button.
- Total distance: It indicates the mileage of the vehicle, which cannot be reset.

### **i** NOTE

This driving information is only displayed in the Sport theme.

### Vehicle state

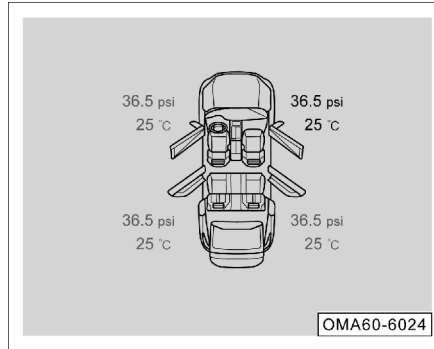

- The displayed information includes tire pressure, temperature, door state, and seat belt alarm message.
- When tire pressure is abnormal, any door is ajar or any seat belt is unfastened, the screen will be exited automatically.

### **i** NOTE

- When the vehicle power switch is set to “ON” position, move up or down the “OK” button on the left of the steering wheel to view the vehicle state.
- The Sport theme is illustrated here and for reference only. Please refer to the actual vehicle.



## 4. Operation of systems and equipment

### Throttle sensitivity



- The displayed information includes current throttle sensitivity, accelerator pedal position and brake pedal position.
- The left semicircle represents brake pedal position, and the right semicircle represents accelerator pedal position.

### i NOTE

- Press "OK" button on the left of the steering wheel to access the setting interface. The throttle sensitivity is in 5 levels, which can be adjusted by moving up or down the "OK" button.
- The throttle sensitivity is only displayed in the Sport theme.

### Fuel consumption trend\*

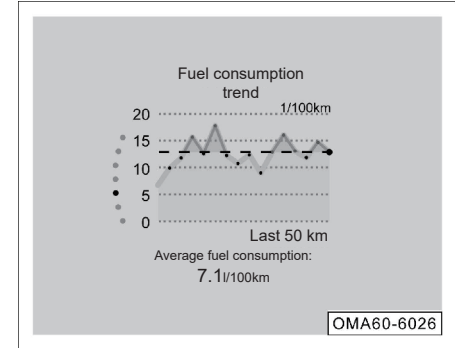

The fuel consumption trend for the last 15 km and the average fuel consumption are displayed.

### i NOTE

- Press "VIEW" button on the left of steering wheel to select Sport theme of the instrument cluster, and move up or down the "OK" button to view the corresponding information.
- The fuel consumption trend chart is only displayed in the Sport theme.

## 4. Operation of systems and equipment

### ADAS



When ADAS function is activated, the corresponding ADAS information, including LDW, FCM, following vehicle, is displayed.

### i NOTE

- This page is not often displayed, and it can only pop up when the relevant alarm is triggered. When this page appears, you cannot switch to another page by pressing the button.
- The Intelligent driving theme is illustrated here and for reference only. Please refer to the actual vehicle.

### Alarm center

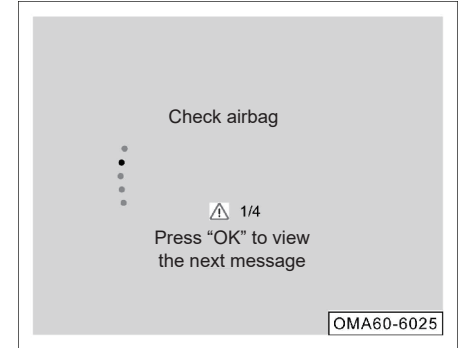

On the alarm center screen, the current state of the vehicle is displayed in the form of texts or pictures. The driver should always pay attention to checking for alarm message.

- If the vehicle is in normal condition, no alarm message is displayed.
- If the vehicle is faulty or certain function is activated/deactivated, corresponding text or picture message will appear at the upper part of the screen of the instrument cluster, reminding the driver about the current state of the vehicle.

## 4. Operation of systems and equipment

- If any alarm message appears, press “OK” button on the left of the steering wheel to confirm the message. Then the message will be displayed on the alarm center screen.
- In case of several alarm messages, corresponding number and current text message will be displayed on the alarm center screen.

### i NOTE

The Sport theme is illustrated here and for reference only. Please refer to the actual vehicle.

### Setting of instrument panel

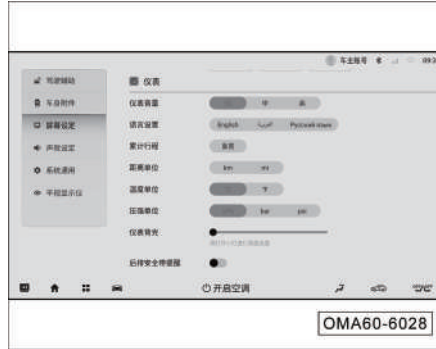

With the vehicle power switch set to “ON” position, when the vehicle speed is zero, perform following function setting via “Settings→Display Setting→Instrument Panel” in the AV system:









- Instrument volume
- Language setting
- Cumulative driving
- Fuel consumption/mileage
- Unit of measurement of temperature
- Unit of measurement of pressure
- Backlight of instrument panel
- Rear seat belt reminder

### i NOTE











For details on instrument panel setting, please refer to System Settings section. => See page 130 and => See page 132

## 4. Operation of systems and equipment

### 4.1.3 Indicator lamp

No.	Icon	Designation	Color	Function
1		Charging system warning lamp	Red	This warning lamp will come on when the engine is not started with the vehicle power switch set to "ON" position, and will go out after the engine is started.
				If this warning lamp comes on after the engine is started, it indicates that the charging system is faulty.
2		Malfunction indicator lamp	Yellow	If there is no fault, this indicator lamp will come on and stay on for a few seconds when the engine is not started with the vehicle power switch set to "ON" position, and then will go out after the system self-test.
				If this indicator lamp comes on after the engine is started, it indicates that the engine system is faulty.
3		Low oil pressure warning lamp	Red	This warning lamp will come on when the engine is not started with the vehicle power switch set to "ON" position, and will go out after the engine is started.
				If this warning lamp comes on after the engine is started, it indicates that the engine oil pressure is low.
4		Emission fault indicator lamp	Yellow	This indicator lamp will come on when the engine is not started with the vehicle power switch set to "ON" position, and will go out after the engine is started.
				If this indicator lamp comes on after the engine is started, it indicates that the exhaust system is faulty.
5		Left turn signal indicator lamp and hazard warning lamp	Green	When the left turn signal indicator lamp flashes alone, it indicates that the left turn signal lamp of the vehicle is on. When the hazard warning lamp switch is pressed, the left / right turn signal indicator lamps and all turn signal lamps outside the car will flash simultaneously.
6		High engine coolant temperature indicator lamp	Red	If the red indicator lamp comes on, it indicates that the engine coolant temperature is too high.
7		Supplemental restraint system (SRS) indicator lamp	Red	If the red indicator lamp comes on, it indicates that the SRS system is faulty.
8		Low fuel level indicator lamp	Yellow	If the yellow indicator lamp flashes, it indicates that the fuel level of the fuel tank is low.
				If the yellow indicator lamp comes on, it indicates that the fuel pump may be faulty.









## 4. Operation of systems and equipment

No.	Icon	Designation	Color	Function
9		Right turn signal indicator lamp and hazard warning lamp	Green	If the right turn signal indicator lamp flashes alone, it indicates that the right turn signal lamp of the vehicle is on. When the hazard warning lamp switch is pressed, the left / right turn signal indicator lamps and all turn signal lamps outside the car will flash simultaneously.
10		Electric park brake (EPB) status indicator lamp	Red	If the red indicator lamp comes on, it indicates that the EPB is applied.
			Green	If the green indicator lamp comes on, it indicates that the EPB is activated.
11		Electric park brake (EPB) fault indicator lamp	Yellow	If the yellow indicator lamp comes on, it indicates that the EPB is faulty.
				If the yellow indicator lamp flashes, it indicates that the EPB is in the service mode.
12		Parking brake and brake system indicator lamp	Red	If the red indicator lamp comes on, it indicates that the brake fluid level is too low or the electronic brake force distribution (EBD) system is faulty.
13		Electronic stability program (ESP) indicator lamp	Yellow	If the yellow indicator lamp comes on, it indicates that the ESP is faulty.
				If the yellow indicator lamp flashes, it indicates that the ESP is working.
14		ESP OFF indicator lamp	Yellow	If the yellow indicator lamp comes on, it indicates that the ESP is off.
15		Anti-lock braking system (ABS) indicator lamp	Yellow	If the yellow indicator lamp comes on, it indicates that the ABS is faulty.
16		Transmission fault indicator lamp	Yellow	If the yellow indicator lamp comes on, it indicates that the transmission system is faulty.
				If the yellow indicator lamp flashes, it indicates that the transmission fluid temperature is high.
17		Tire pressure monitoring system (TPMS) indicator lamp	Yellow	If the yellow indicator lamp comes on, it indicates that the TPMS is faulty.
18		Electric power steering (EPS) indicator lamp	Red	If the red indicator lamp comes on, it indicates that the EPS system is faulty.
19		Cruise control indicator lamp*	White	If the white indicator lamp comes on, it indicates that the cruise control is in the ready state.
			Green	If the green indicator lamp comes on, it indicates that the cruise control is activated.

## 4. Operation of systems and equipment

No.	Icon	Designation	Color	Function
20		Intelligent high beam indicator lamp *	White	If the white indicator lamp comes on, it indicates that the intelligent high beam is in standby state.
			Blue	If the blue indicator lamp comes on, it indicates that the intelligent high beam is activated.
21		ACC indicator lamp (no vehicle ahead) *	Gray	If the gray indicator lamp comes on, it indicates that the ACC system is in the ready state, and there is no target vehicle ahead.
			Blue	If the blue indicator lamp comes on, it indicates that the ACC system is working, and there is no target vehicle ahead.
22		ACC indicator lamp (a vehicle ahead) *	Gray	If the gray indicator lamp comes on, it indicates that the ACC system is in the suppression or ready state, and there is a target vehicle ahead.
			Blue	If the blue indicator lamp comes on, it indicates that the ACC system is working, and there is a target vehicle ahead.
23		ACC fault indicator lamp *	Yellow	If the yellow indicator lamp comes on, it indicates that the ACC system is faulty.
24		LDW status indicator lamp*	White	If the white indicator lamp comes on, it indicates that the LDW system is activated.
			Red	If the red indicator lamp comes on, it indicates that the LDW system is faulty. In that case, please go to the GAC Motor authorized shop for inspection in time.
			Green	If the green indicator lamp comes on, it indicates that the LDW system is working normally or intervenes with the steering wheel for deviation correction.
25		FCWS status indicator lamp *	Yellow	If the yellow indicator lamp comes on, it indicates that the FCWS is faulty. In that case, please go to the GAC Motor authorized shop for inspection in time.
			Red	If the red indicator lamp flashes, it indicates that the FCWS is being triggered and activated.
26		Front passenger's seat belt indicator lamp	Red	If the red indicator lamp comes on, it indicates that the front passenger's seat belt is not fastened or the system is faulty.
27		Driver's seat belt indicator lamp	Red	If the red indicator lamp comes on, it indicates that the driver's seat belt is not fastened or the seat belt system is faulty.
28		High beam indicator lamp	Blue	If the blue indicator lamp comes on, it indicates that the high beam is on.

## 4. Operation of systems and equipment

No.	Icon	Designation	Color	Function
29		Position lamp indicator lamp	Green	If the green indicator lamp comes on, it indicates that the position lamp, instrument panel lamp, license plate lamp, etc. are on.
30		Rear fog lamp indicator lamp	Yellow	If the yellow indicator lamp comes on, it indicates that the rear fog lamp is on.
31		BSD system status indicator lamp *	Green	If the green indicator lamp comes on, it indicates that the BSD system is activated.
			Yellow	If the yellow indicator lamp comes on, it indicates that the BSD system is faulty.
32		Hill descent control (HDC) indicator lamp	Yellow	If the yellow indicator lamp comes, it indicates that the HDC system is activated.
33		Hands off warning lamp*	Green	If the green indicator lamp comes on, it indicates that hands on steering wheel is detected by ICA.
			Yellow	If the yellow indicator lamp comes on, it indicates that hands off steering wheel is detected by ICA.
34		LKA status indicator lamp*	Gray	If the gray indicator lamp comes on, it indicates that ICA is in standby state.
			Blue	If the blue indicator lamp comes on, it indicates that ICA is activated.
			Yellow	If the yellow indicator lamp comes on, it indicates that ICA is faulty.
35		Rear seat belt indicator lamp	White	If the white indicator lamp comes on, it indicates that the corresponding rear seat belt is fastened.
			Red	If the red indicator lamp comes on, it indicates that the rear seat belt is not fastened or the seat belt system is faulty.
36		4WD locking mode indicator lamp*	Green	If the green indicator lamp comes on, it indicates that the 4WD is currently in locking mode.
37		4WD intelligent mode indicator lamp*	Yellow	If the yellow indicator lamp comes on, it indicates that the intelligent 4WD system is overheated.

Note: If any indicator or warning lamp on the instrument cluster comes on after the vehicle is started or during driving, it indicates that the related system or function is in a certain working state or faulty. Therefore, you should read carefully and understand the meaning of each indicator or warning lamp. In case of a fault, please go to or contact the GAC Motor authorized shop for inspection in time.

## 4. Operation of systems and equipment

### 4.2 Vehicle locking and unlocking

#### 4.2.1 Remote control key

This vehicle is accompanied with two intelligent remote control keys (including emergency mechanical key) and the corresponding key barcodes. If the key needs to be re-customized, please inform the GAC Motor authorized shop of the key barcode. If the key barcode is missing, please inform the GAC Motor authorized shop of the VIN.

#### NOTE

After the engine is started, do not place the remote control key on the instrument panel under the front windshield, otherwise the prompt “No key detected” may appear.

#### **Poor signal strength of remote control key**

The operation of the remote control key button may be interfered or unstable in the following cases:

- Nearby equipment is emitting strong radio waves.

- The remote control key is carried together with telecommunication equipment, laptop, mobile phone, access control card or wireless signal transmitter.
- The remote control key is put together with magnetic cards (such as bank card and bus card).
- Metal objects contact or cover the remote control key.

#### CAUTION

The remote control key contains an electronic circuit that can trigger the engine immobilizer system. If the circuit is damaged, the engine may not be started. Therefore,

- Avoid placing the remote control key in direct sunlight or in a high-temperature or humid place.
- Avoid dropping the remote control key from a high place or crushing it by heavy objects.
- Avoid exposing the remote control key to any liquid. If the key gets wet accidentally, dry it immediately.

#### NOTE

- The buttons of the remote control key do not work when the vehicle power switch is set to “ACC” or “ON” position.
- If the unlocking or locking function of the remote control key is deactivated, you can try to press the buttons on the remote control key 3 times continuously to activate the function.



### Liftgate unlocking button



- ① : Locking button
- ② : Unlocking button
- ③ : Liftgate unlocking button
- ④ : Engine start/stop button

### ① Button operation

- If this button is pressed once within the effective range of the remote control key, all doors will be locked; if this button is pressed and held, the windows and sunroof \* will be automatically closed; if the button is released when the windows or the sunroof \* is being closed automatically, the windows or the sunroof \* will stop moving.
- When the automatic window closing when hirecar is activated, if this button is pressed once within the effective range of the remote control key, the windows and sunroof \* will be automatically closed.
- If this button is pressed continuously within 0.5 s, the vehicle locating function will be realized and the turn signal lamps will flash 3 times quickly.

### CAUTION

Before closing the windows or sunroof \* by the remote control key, make sure that there are no body parts (such as head and hands) in the movement path of the windows or sunroof \* so as to prevent a risk of pinch injury.

### NOTE

- The automatic window closing when hirecar can be activated or deactivated via “Settings → Body Accessories → Lock → Automatic Window Closing When Hirecar” in the AV system.
- When the doors are locked, the turn signal lamps will flash once and the horn will sound once. The horn prompt can be activated or deactivated via “Settings → Sound Effect Settings → System Sound Effect → Unlocking/Locking Horn” in the AV system.

## 4. Operation of systems and equipment

### ② Button operation

- If this button is pressed once within the effective range of the remote control key, all doors will be unlocked; if this button is pressed and held, the windows will be automatically opened and the sunroof \* will be automatically tilted; if the button is released when the windows are being opened or the sunroof \* is being tilted, the windows or the sunroof \* will stop moving.

### CAUTION

If the door is not opened within 30 s after being unlocked by pressing the unlocking button  on the remote control key, the system will lock the door again.



### NOTE

- When the doors are unlocked, the turn signal lamps will flash twice and the horn will sound twice. The horn prompt can be activated or deactivated via “Settings → Sound Effect Settings → System Sound Effect → Unlocking/Locking Horn” in the AV system.
- The driver’s door or all doors can be unlocked by pressing the button  after setting via “Settings → Body Accessories → Locking/Unlocking → Remote Unlocking (System Settings → Body Accessories → Lock → Remote Unlocking)” in the AV system.



### ③ Button operation

- Within the effective range of the remote control key, two presses on this button twice can open or close the liftgate electrically. If you press this button again during the opening or closing process, the liftgate will stop at the current position.

### ④ Button operation

- Within the effective range of the key, if the  button is pressed and then the  button is pressed and held within 5 s, the turn signal lamps will flash and the engine can be remotely started.
- Then if the  button is pressed and held for 3 s, the engine can be remotely stopped.

### **i** NOTE

- Before remotely stopping the engine, make sure that the vehicle is locked. If you are not sure about it, press the  button once, and then press and hold the  button to remotely stop the engine.
- To remotely stop the engine, keep the key within the effective range, otherwise the unlocking function may be triggered and then the engine cannot be started.
- The maximum default start hold duration is 5 min. If you need to change the duration, please go to GAC Motor authorized shop to change it.

### Battery replacement



Each time you press the buttons on the remote control key, the indicator lamp of the key will flash once. If the indicator lamp fails to flash, or you need to press the buttons several times to lock or unlock the doors, the battery may be exhausted or about to run out. It is recommended to go to the GAC Motor authorized shop for the battery replacement.

### CAUTION

- Be sure to replace the battery with a new one of the same model.
- An inappropriate battery may damage the remote control key.
- Always comply with relevant environmental regulations to dispose the exhausted battery.

### Battery replacement steps



- Press the locking button  and pull out the emergency mechanical key  as arrowed.

## 4. Operation of systems and equipment

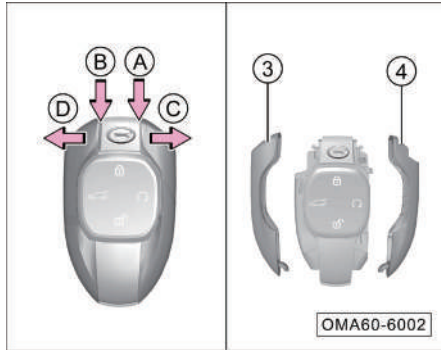

- Use a slotted screwdriver wrapped by cloth to pry open the chrome plated housing of the remote control key at positions (arrows A and B) in the direction of arrows C and D.
- Take off the chrome plated housings (3) and (4) of the remote control key.

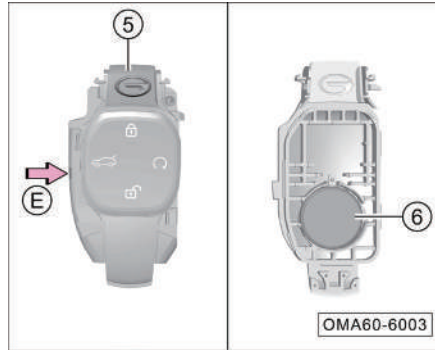

- Take off the transparent trim cover (5).
- Use a slotted screwdriver wrapped by cloth to pry open the housing of the remote control key at position (arrow E).
- Take out the battery (6).
- Assemble the remote control key in the reverse steps mentioned above.

### 4.2.2 Emergency mechanical key

#### Emergency mechanical key

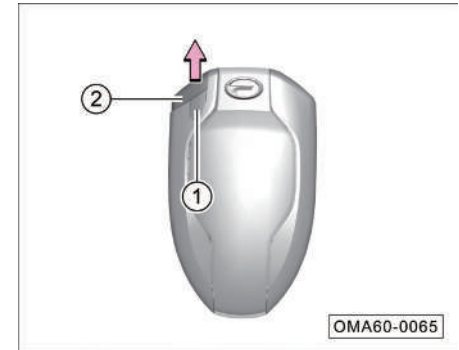



- Press the locking button (1) and pull out the emergency mechanical key (2) as arrowed.

### 4.2.3 Door lock system

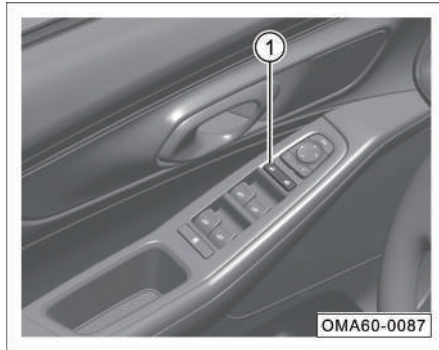
#### Central locking button



The central locking button ① can be used to lock and unlock the doors in the vehicle:

- Lock all the doors: Press the  end of ① button.
- Unlock all the doors: Press the  end of ① button.

#### Door inside handle

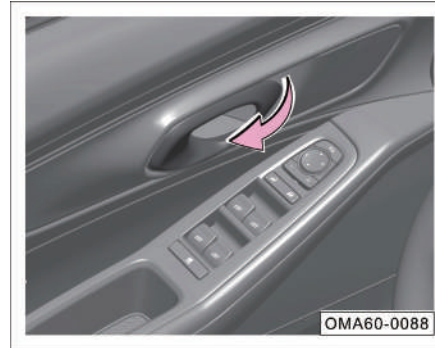

- If the vehicle is locked, pull the inside handle of any door once to unlock that door only; pull the inside handle of that door again to open that door.
- If the vehicle is unlocked, pull any door handle once to open the door directly.

#### NOTE

When the child safety lock is activated (=> [See page 56](#)), even if the rear door latch is unlocked, the inside handle cannot open the rear door. In this case, the rear door shall be opened from outside. And do not pull the inside handle with force to avoid damages.

#### CAUTION

- Before driving the vehicle, make sure that all doors are properly closed and locked.
- Do not pull the inside handle during driving to avoid accidents due to opening of door.
- When opening or closing the door, check the surroundings of the vehicle, such as whether the vehicle is on a slope, whether there is enough space to open the door or whether there is strong wind. When opening or closing the door, please firmly hold the door handle to prepare for any unpredictable movement.

## 4. Operation of systems and equipment

### Door lock hole

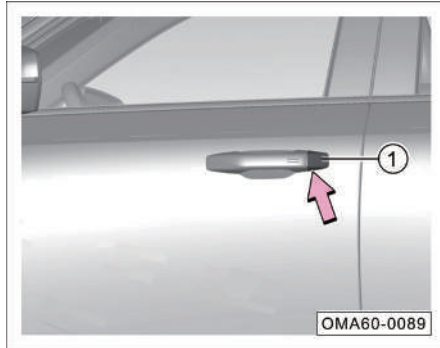

- Take out the emergency mechanical key.  
=> See page 54
- Insert the mechanical key into the notch on the trim cover of mechanical lock of left front door, gently pry up the trim cover, pull up the door handle and remove the trim cover.

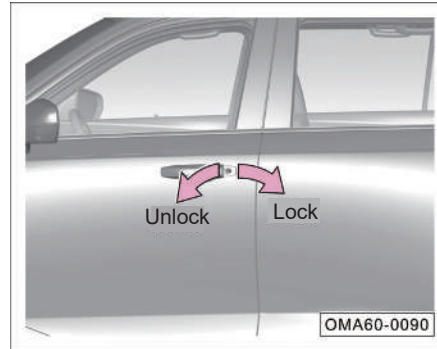

- Insert the emergency mechanical key into the driver's door lock hole.
- Turn the key anticlockwise to unlock the driver's door only.
- Turn the key clockwise to lock all the doors.

### Child safety lock

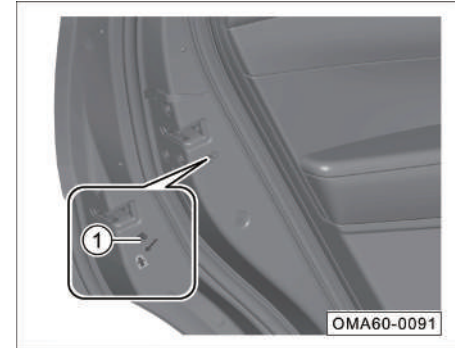

- Activation: Move the child safety lock switch ① as arrowed to locking position to activate the child safety lock.
- Deactivation: Move the child safety lock switch ① in opposite direction to the arrow to unlocking position to deactivate the child safety lock.

### NOTE

- Before driving the vehicle, if any child sits in the rear seat, make sure that the child safety lock is activated.
- When the child safety lock is activated, the rear door cannot be opened by operating the inside handle. In this case, the rear door shall be opened from outside. And do not pull the inside handle with force to avoid damages.

### WARNING

**When the child safety lock is activated, never leave children or handicapped persons in the vehicle alone. Once the doors are locked, it is difficult for children or handicapped persons to leave the vehicle in an emergency; locked doors in an accident will make it more difficult to rescue persons inside the vehicle.**

### Automatic unlock function

If the vehicle stops with the doors locked and the vehicle power switch set to "OFF" position, the four doors will be automatically unlocked.

### NOTE

This function can be activated or deactivated via "Settings → Body Accessories → Lock → Auto Unlock" in the AV system.

### Speed sensing door lock

If this function is activated with all doors closed, the vehicle will be automatically locked at certain vehicle speed or after certain driving time.

With the vehicle power switch set to "ON" position, whether locked automatically or manually, all doors will be automatically unlocked if the system detects that the vehicle has suffered a severe collision. Depending on the impact force and impact range, the system may not work under extreme conditions.

### NOTE

- This function is deactivated by default. Please read the above related content before activating this function.
- This function can be activated or deactivated via "Settings → Body Accessories → Lock → Speed Sensing Door Lock" in the AV system.

## 4. Operation of systems and equipment

### Collision unlock function

With doors locked and the vehicle power switch set to "ON" position, when the system detects that the vehicle has suffered a severe collision, all doors will be automatically unlocked. Depending on the impact force and impact range, the system may not work under extreme conditions.

### Intelligent active unlock

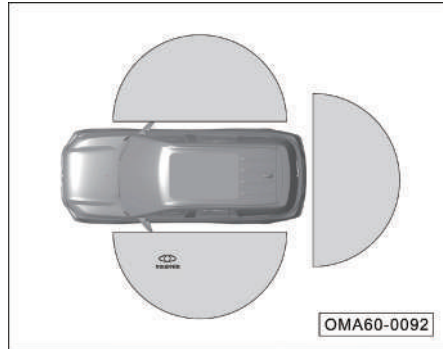

- When the intelligent active unlock function is activated and the intelligent remote control key is brought to the area within 1.2 m of the vehicle, the vehicle will be automatically unlocked.

### i NOTE

- This function can be activated or deactivated via "Settings → Body Accessories → Lock → Intelligent Active Unlock" in the AV system.
- If the intelligent active unlock is successful, the turn signal lamps will flash twice and the horn will sound twice.
- When the vehicle has been not in use for more than 7 days, the intelligent active unlock function will be automatically deactivated in order to reduce the power consumption of the vehicle, and in this case, you need to use the intelligent remote control key or touch the door handle to unlock the doors, and after the vehicle is started, the intelligent active unlock function will be restored.

### Intelligent active lock

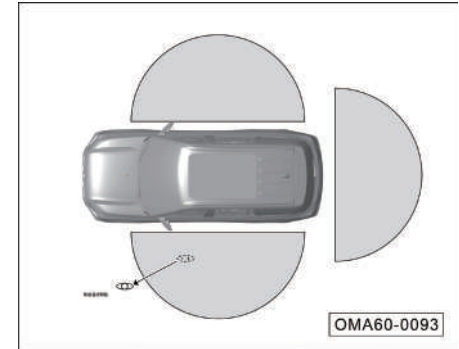

- With the intelligent active lock function activated and the vehicle power switch set to "OFF" position, after all doors are closed, if the intelligent remote control key is taken away from the vehicle to an area within 2 m from the vehicle for more than 2 min or to an area more than 2 m away from the vehicle, the vehicle will be automatically locked and the exterior rearview mirror will be automatically folded.
- If the key remains in an area within 2 m from the vehicle for more than 2 minutes, the system will temporarily deactivate the intelligent active lock function for the purpose of power saving; the user needs to open and then close one of the doors to reactivate the intelligent active lock function.



## 4. Operation of systems and equipment

- If the intelligent active lock function is activated and the key remains in an area within 2 m from the vehicle, the indicator lamp of the intelligent remote control key will flash continuously until the doors are locked.

### CAUTION

With the intelligent active lock function activated, if the key is taken away from the vehicle to an area within 3 m from the vehicle for more than 2 min, the vehicle will confirm that the key is not within the vehicle and then be locked automatically; in case the time is longer than 4 min, the PEPS function will be deactivated.

### NOTE

- This function can be activated or deactivated via “Settings → Body Accessories → Lock → Intelligent Active Lock” in the AV system.
- If the intelligent active lock is successful, the turn signal lamps will flash once and the horn will sound once.
- If the intelligent active lock is activated successfully but the liftgate is ajar, the audible and visual alarms will be triggered to remind you.
- If one of the doors is ajar, there will be a corresponding indication on the instrument cluster.

The intelligent active lock function will not be activated in case of the followings:

- The vehicle power switch is set to “ACC” or “ON” position.
- The intelligent remote control key is in the vehicle.
- No intelligent remote control key is detected within 2 m of the vehicle.
- The intelligent remote control key is thrown into the vehicle from the door window.
- The intelligent remote control key is in the trunk.
- Any door (excluding the engine hood and liftgate) is ajar.
- The battery voltage is low.
- The PEPS antenna is faulty.

## 4. Operation of systems and equipment

### CAUTION

- The intelligent active lock function cannot automatically close the door windows and sunroof \*, so before leaving the vehicle, make sure that all windows and sunroof \* are closed.
- Do not leave children or handicapped persons in the vehicle alone when using the intelligent active lock function.

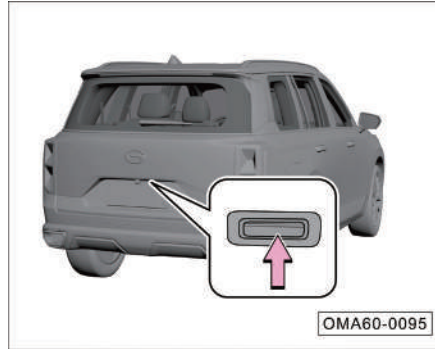

- With the vehicle power switch set to "OFF" position, if you carry the intelligent remote control key to approach the liftgate, and press the liftgate unlocking button, the liftgate will be unlocked and opened.
- When the vehicle is unlocked and stationary, if you press the liftgate unlocking button directly without carrying the intelligent remote control key, the liftgate will also be unlocked and opened.

### 4.2.4 Door

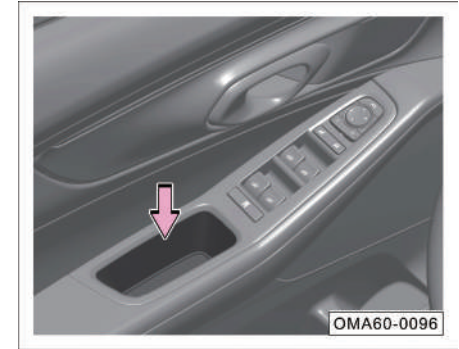

- To close the door from inside, grab the door handle and pull it inward.
- To close the door from outside, directly push the door toward the vehicle.

### CAUTION

Before opening the door, always pay attention to other vehicles or pedestrians outside the vehicle to avoid accidents caused by collision.

### WARNING

- Always ensure that all doors are closed to prevent unexpected opening during driving, which may cause personal injuries or accident.
- Open or close the doors only when the vehicle is stationary.
- Do not put your hands on the edge of the door when closing the door, otherwise there will be a risk of pinching.

### NOTE

- If the door is not closed properly, please re-open the door and close it again.
- If the door is ajar, there will be a corresponding indication on the instrument cluster; then when the vehicle speed exceeds 5 km/h, a buzzer will sound.

### 4.2.5 Liftgate

#### Unlocking liftgate with remote control key

Within the effective range of the remote control key, two presses on the  button can unlock the liftgate.

- When the power liftgate function is deactivated, the liftgate needs to be opened manually.
- When the power liftgate function is activated, the liftgate will be electrically opened to the set position. During opening, if you press this button again, the liftgate will stop opening.

#### Unlocking liftgate with PEPS function

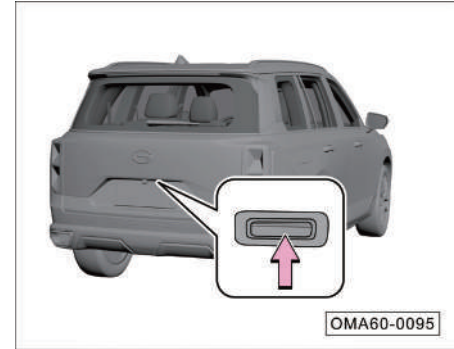

If you carry the intelligent remote control key, which is in the effective range, press the liftgate unlocking button to unlock the liftgate.

- When the power liftgate function is deactivated, the liftgate needs to be opened manually.
- When the power liftgate function is activated, the liftgate will be electrically opened to the set position. During opening, if you press this button again, the liftgate will stop opening.

## 4. Operation of systems and equipment

### **i** NOTE

When the vehicle is unlocked and stationary, if you press the liftgate unlocking button directly without carrying the intelligent remote control key, the liftgate will also be unlocked and opened.

### Unlocking liftgate with button on instrument panel

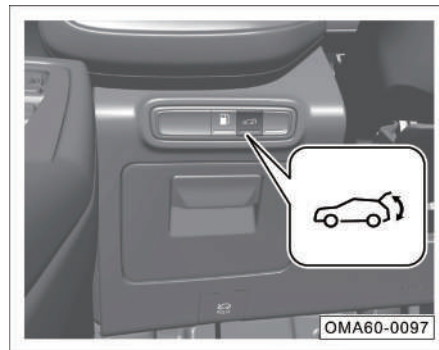

Press the liftgate button on the instrument panel to electrically open/close the liftgate. In this process, press the button again to suspend opening/closing of the liftgate.

### **eye** CAUTION

As the liftgate button on the instrument panel sends an action signal that does not identify opening or closing, the liftgate will confirm the relevant action according to the current state and the last action. For example, if the opening action was previously suspended, pressing the button will close the liftgate, and vice versa.

### **i** NOTE

The power liftgate function can be activated or deactivated via “Settings → Body Accessories → Lock → Power Liftgate” in the AV system; when the power liftgate function is deactivated, the liftgate needs to be closed manually.

### Operation of inside switch of liftgate

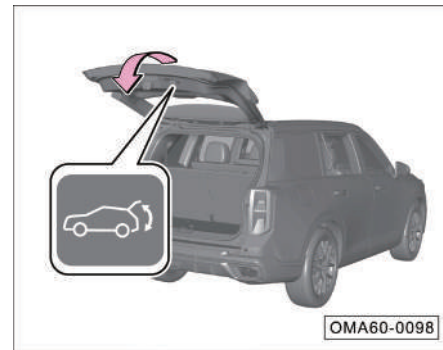

- Press the inside switch of the liftgate to electrically close the liftgate.
- In this process, press the inside switch again to suspend opening/closing of the liftgate.

## 4. Operation of systems and equipment

Setting of second height of liftgate:

When the height of opening of liftgate is 55%~98%, press and hold the inside switch of liftgate for 2 s to set the second height of liftgate successfully.

### CAUTION

As the inside switch of liftgate sends an action signal that does not identify opening or closing, the liftgate will confirm the relevant action according to the current state and the last action. For example, if the opening action was previously suspended, pressing the inside switch will close the liftgate, and vice versa.

### Control of power liftgate through car model in center console display



After the AV system works normally, click on “3D car model in smart scenario” in the main interface or the “My Car” soft key in the application menu interface to enter the My Car interface.

- If you click “Liftgate” → “Open liftgate” or “Close liftgate” button, the liftgate will be opened or closed electrically.
- Drag the liftgate icon to set the target positions of 20%, 40%, 60%, 80% and 100%, and release the liftgate icon to allow the liftgate to move to the set target positions.

- In this process, drag the liftgate icon again to suspend opening/closing of the liftgate.
- When the height of opening of liftgate is 55%~98%, click “Memory position” to set the second height of liftgate successfully.
- Click “Clear memory position” to clear the second height of liftgate successfully.

### Voice control of power liftgate

After you wake up the voice recognition system and hear a beep, you can perform the voice control of the power liftgate.

- When the driver gives the voice command “open the liftgate”, the liftgate will be opened electrically.
- When the driver gives the voice command “close the liftgate”, the liftgate will be closed electrically.

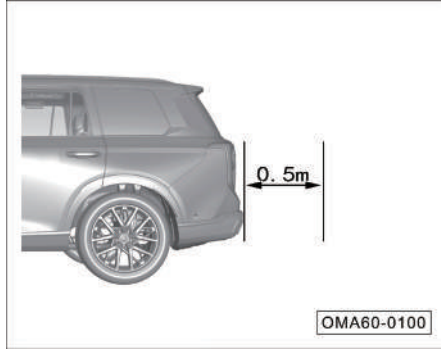

## 4. Operation of systems and equipment

### Easy open of power liftgate\*



- With the vehicle power switch set to "OFF" position and the four doors and liftgate closed, if you take the intelligent remote control key to enter the induction area within about 0.5 m from the liftgate, the horn will sound once and the turn signal lamps will start to flash, and if you stay there or take a step back, the liftgate will be automatically opened. If you leave the induction area when the high-mounted stop lamp flashes (4 times, lasting for 3.2 s), the liftgate will not be opened.

### i NOTE

- When the liftgate is automatically opened, the horn will sound once, the high-mounted stop lamp will flash 4 times, and the turn signal lamps will flash twice.
- If you leave the liftgate induction area or press the  button on the intelligent remote control key during the flashing of the high-mounted stop lamp, this function will be temporarily deactivated and the liftgate will not be opened. If this function is deactivated by pressing the  button on the intelligent remote control key, you need to reactivate it by opening and closing one door.
- This function can be activated or deactivated via "Settings → Body Accessories → Lock → Easy Open of Power Liftgate" in the AV system.

### 👁 CAUTION

- When washing the vehicle, make sure that the intelligent remote control key is outside the induction area of the liftgate; otherwise the liftgate will be opened. Therefore, it is recommended to deactivate this function in this case.
- If you pick up something near the liftgate while carrying the intelligent remote control key, please note that the liftgate may be opened.
- Before activating the easy open function to open the liftgate, make sure that no one or obstacle is within the movement range of the liftgate.

## 4. Operation of systems and equipment

### Emergency opening of liftgate

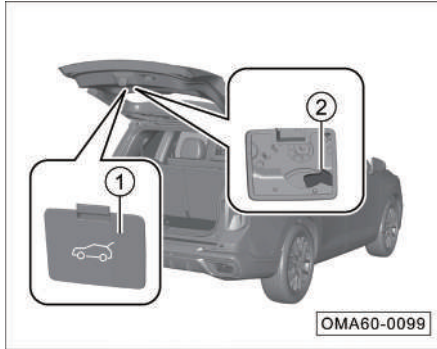

When the vehicle is out of power or the liftgate fails to be opened normally, please try the emergency interior opening of liftgate:

1. Fold down the third-row seat back. => [See page 95](#)
2. Open the liftgate trim cover ①.
3. Operate the emergency switch ② of the liftgate to unlock and open the liftgate in case of an emergency.

### Closing of liftgate



#### PLG closing\*

- If you press the liftgate locking button ①, the PLG will be automatically lowered until it is closed. In this case, if you press this button again during the closing process, the liftgate will stop at the current position.
- If you press and hold the button  on the intelligent remote control key within the effective range, the PLG will be automatically lowered until it is closed. In this case, if you press this button again during the closing process, the PLG will stop at the current position.

- Within the effective range of the intelligent remote control key, if you press the  button twice, the PLG will be automatically lowered until it is closed. In this case, if you press this button again during the closing process, the PLG will stop at the current position.

#### Manual closing

When the liftgate is not electrically controlled, the liftgate needs to be closed manually:

- Lower the liftgate to the position close to the rear bumper cover, and then press down the liftgate firmly with both hands to close it.

## 4. Operation of systems and equipment

### **i** NOTE

- When the PLG is closed from a stationary state, the turn signal lamps will flash twice and the buzzer will sound.
- When the PLG is closed, the buzzer will beep intermittently.
- If the liftgate is not properly closed, the instrument cluster will indicate that the liftgate is ajar; when the vehicle speed exceeds 5 km/h, the buzzer will sound.

### **👁** CAUTION

- The PLG must always be closed fully, otherwise accidents are likely to occur.
- Be careful when closing the liftgate to ensure that no person or obstacle is within the movement range of the liftgate.
- Always ensure that the closed PLG is locked to prevent suddenly opening during driving.

### 4.2.6 Engine hood

#### Opening of engine hood



- When the engine hood release handle ① is pulled for the first time, the engine hood will be semi-unlocked and pop up slightly.
- When the engine hood release handle ① is pulled for the second time, the engine hood will further pop up slightly again and be fully unlocked. At this time, the engine hood can be opened outside the vehicle.



## 4. Operation of systems and equipment

### Closing of engine hood

- Lower the engine hood to a height close to the fenders, and then press down the front end of the engine hood with force for firm locking.

#### WARNING

- Before driving, ensure that the engine hood is closed and locked, otherwise, it may suddenly open during driving, resulting in dangerous accidents.
- If the engine hood is ajar, the instrument cluster will display the corresponding alarm information; when the vehicle speed exceeds 5 km/h, the buzzer will sound. In this case, please stop driving immediately and close and lock the engine hood correctly.

### 4.2.7 Power window

The power window can be operated when the ignition is in the “ON” position, and stays operable within 30 s after the ignition is switched from the “ON” position to the “ACC” or “OFF” position, but will become inoperable if any one of the doors is opened within this 30 s.

#### CAUTION

- Please close all windows before leaving the vehicle.
- Do not put your hands on the edges of the windows when closing the windows, otherwise there will be a risk of pinching.

### Driver's power window control button

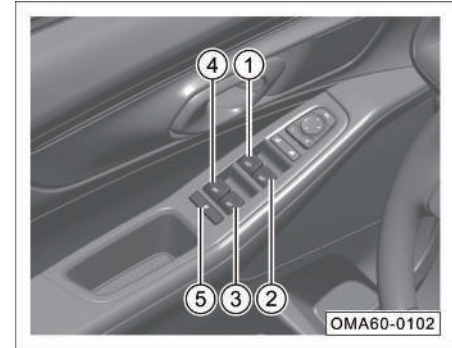

- ① Left front power window button
- ② Right front power window button
- ③ Right rear power window button
- ④ Left rear power window button
- ⑤ Passenger's power window lock button

## 4. Operation of systems and equipment

- If the button ① is pulled up to the first stop position, the power window will be lifted for closing until the button is released or the window reaches the highest position.
- If the button ① is pulled up to the limit position, the power window will be lifted automatically for closing until the window reaches the highest position.
- If the button ① is pressed down to the first stop position, the power window will be lowered for opening until the button is released or the window reaches the lowest position.
- If the button ① is pressed down to the limit position, the power window will be lowered automatically for opening until the window reaches the lowest position.

### **i** NOTE

- If you want to stop the window during the automatic lifting or lowering, just press down/pull up the button ①.
- The operation methods of the buttons ②, ③ and ④ are the same as that of the button ①, only corresponding to the respective windows.

- If you press the passenger's window lock button ⑤, the button indicator lamp will come on and the passenger's power windows cannot be operated anymore. If you press this button again, this function will be deactivated and the button indicator lamp will go out.

### Passenger's power window control button

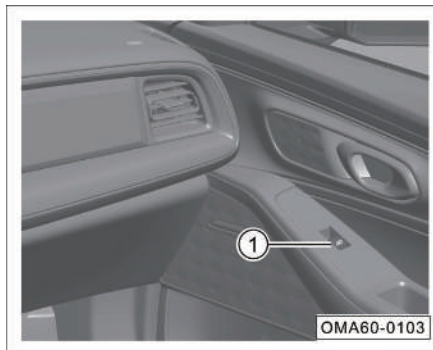

- For the operation methods of the passenger's power window control button ①, please refer to the driver's power window control button.

### Initialization of anti-pinch function

If the express-up function is not available, or the anti-pinch function fails, or the initialization becomes invalid automatically because the anti-pinch function is triggered multiple times in a short period of time, the power window needs to be initialized again.

1. Pull up the power window control button, and then the window is lifted in steps until it is completely closed.
2. After the window is completely closed, continue to pull up the power window control button for about 1 s for initialization.

### **⚠** WARNING

- If the window has no anti-pinch function during the initialization learning process, please do not use any part of your body or other objects to hinder the closing of the window, otherwise it will cause personal injury and affect the result of the initialization learning.
- If the power window system fails, please go to the GAC Motor authorized shop for inspection in time.

## 4. Operation of systems and equipment

### Locking-sensitive window closing function\*

If you close and lock the doors without closing the windows (door locking by remote control key, or intelligent door locking when you leaving the vehicle), the system will automatically close the windows to prevent the vehicle from being damaged. This function can be activated or deactivated via “Settings → Body Accessories → Other Accessories → Automatic Window Closing When Hirecar” in the AV system. If the window fails to be closed automatically due to abnormal conditions such as activation of an-ti-pinch function, the horn will sound 4 times to remind the user that the window closing fails.

### Rain-sensitive window closing function\*

If rain is detected with IGN OFF, the window will automatically close.

#### CAUTION

The locking-sensitive window closing function and the rain-sensitive window closing function are effective only when the sensor, battery SOC and other relevant parts are normal. Do not leave the vehicle until it is confirmed that the windows are fully closed.

### Automatic window calibration

If the window cannot be automatically lifted due to external factors, the window will first lower to the bottom for automatic calibration before automatic lifting.

#### CAUTION

Under special circumstances, an individual window may not be automatically lifted, and in this case, users are required to manually lift windows for calibration.

### 4.2.8 Power sunroof\*

The power sunroof is operable only when the ignition is in the “ON” position. After the ENGINE START/STOP button is switched from “ON” position to “ACC” or “OFF” position, the power sunroof can still be operated within 30 s during which if you open any door, the power sunroof cannot be operated any more.

#### NOTE

When the ignition is in the “OFF” position with the power sunroof not closed and the driver’s door opened, the instrument cluster will display the message “Sunroof Open” and send a buzzer sound; in this case, be sure to check whether the sunroof is closed.

#### CAUTION

Please close the sunroof, otherwise there will be a risk of water ingress on rainy days.

## 4. Operation of systems and equipment

### Electric sunshade



- To open the electric sunshade slightly, press the switch ①, and then the electric sunshade will move in the opening direction for a short distance and then stop.
- To close the electric sunshade slightly, press the switch ②, and then the electric sunshade will move in the closing direction for a short distance and then stop.
- To fully open the electric sunshade, press and hold the switch ① for several seconds, and then the electric sunshade will automatically move to the fully opened position.

- To fully close the electric sunshade, press and hold the switch ② for several seconds, and then the electric sunshade will automatically move to the fully closed position.

### **i** NOTE

- The electric sunshade will be automatically closed as the sunroof is closed.
- If the switch is pressed during the automatic opening or closing of the electric sunshade, the electric sunshade will stop at the current position.

### **👁** CAUTION

Do not touch the sunshade with hand or object when it is opening or closing; otherwise, the sunshade may incur wrinkle, dislodgement or even failure.

### Opening or closing of sunroof



- To open the sunroof slightly, push the sunroof switch ① backward, and then the sunroof will move in the opening direction for a short distance and then stop.
- To close the sunroof slightly, push the sunroof switch ① forward, and then the sunroof will move in the closing direction for a short distance and then stop.
- To fully open the sunroof, push the sunroof switch ① backward and hold it for a short time. The sunroof will automatically open to the fully open position.

## 4. Operation of systems and equipment

- To fully close the sunroof, push the sunroof switch ① forward and hold it for a short time. The sunroof will automatically move to the fully closed position.

### **i** NOTE

- The electric sunshade will be automatically opened as the sunroof is opened.
- If the sunroof switch ① is briefly pushed forward or backward during the automatic opening or closing of the sunroof, the sunroof will stop at the current position.

### Tilting of sunroof

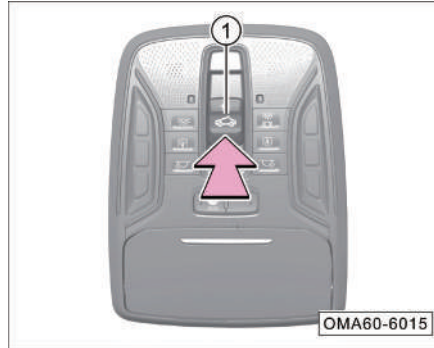

- When you press the sunroof switch ① with sunroof fully closed, the sunroof will be tilted outward. Just push the sunroof switch ① forward to deactivate the tilting function.

### Remote control

When you press and hold the button  on the remote control key with IGN OFF, the sunroof will be closed by remote control, and when you release the button, the sunroof will stop closing.

When you press and hold the button  on the remote control key with IGN OFF, the sunroof will be tilted, and if you release the button during tilting, the sunroof will stop.

### **i** NOTE

The remote control is available for the tilting and closing of sunroof, and is not applicable to the opening of sunroof.

### Speech operations

The speech operations can be used to open, close and tilt the sunroof, as well as to open and close the sunshade:

- If you say “Open sunroof”, the sunroof will be fully opened automatically, during which the electric sunshade will be opened accordingly.

## 4. Operation of systems and equipment

- If you say “Close sunroof”, the sunroof will be fully closed automatically, during which the electric sunshade will be closed accordingly.
- If you say “I need some fresh air/Tilt sunroof”, the sunroof will be automatically tilted and the sunshade will be automatically opened half or more.
- If you say “Open sunshade”, the electric sunshade will be opened (but the sunroof will not move);
- If you say “Close sunshade”, the electric sunshade will be closed (and the sunroof will be closed accordingly);

### **i** NOTE

The results of voice commands of “Close sunroof” and “Close sunshade” are the same, that is, the whole sunroof system will be closed.

### AV display control

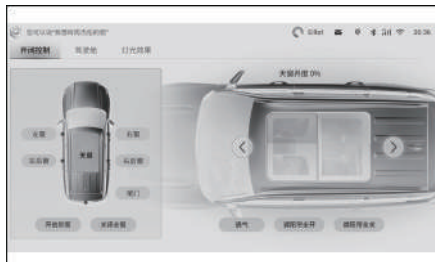

Control the opening and closing of the sunroof and sunshade via “My Car” soft key or “Opening and Closing Control → Sunroof \* → Fresh Air, <, >, Full Opening of Sunshade, Full Closing of Sunshade” soft keys in the 3D vehicle model on the AV system display.

### Anti-pinch function of sunroof

The anti-pinch function is available for the sliding closing and the downward tilting closing of the sunroof, and is to prevent large objects from being pinched when the sunroof is closed.

- If the anti-pinch function is activated when the sunroof is closed by sliding, the sunroof will move in the opening direction for a certain distance and then stop.
- If the anti-pinch function is activated when the sunroof is closed by tilting, the sunroof will move in the outward tilting direction until it reaches the maximum tilting position.

### **👁** CAUTION

Do not operate the sunroof when the ambient temperature is below -20°C, at which the anti-pinch function of the sunroof may not be activated, resulting in accidents. In addition, the low temperature will also damage the motor to a certain extent.

### WARNING

- The anti-pinch function of the sunroof cannot prevent pinching of light or thin objects.
- When closing the sunroof, make sure that no one is within the movement range of the sunroof to avoid unexpected pinching.
- The sunroof will stop detecting obstacles at a position where the sunroof is about to be closed fully, so the anti-pinch function will be deactivated at this time.
- Do not try to activate the anti-pinch function by your hand or any part of your body, otherwise there will be a risk of pinching.

### Locking-sensitive sunroof closing function

If you close and lock the doors without closing the sunroof (door locking by remote control key, or intelligent door locking when you leaving the vehicle), the system will automatically close the sunroof to prevent the vehicle from being damaged. This function can be activated or deactivated via “Settings → Body Accessories → Other Accessories → Automatic Window Closing When Hirecar” in the AV system. If the sunroof fails to be closed automatically due to abnormal conditions such as activation of anti-pinch function, the horn will sound 4 times to remind the user that the sunroof closing fails.

### Rain-sensitive sunroof closing function

If rain is detected with IGN OFF, the sunroof will automatically close.

### CAUTION

The locking-sensitive sunroof closing function and the rain-sensitive sunroof closing function are effective only when the sensor, battery SOC and other relevant parts are normal. Do not leave the vehicle until it is confirmed that the sunroof is fully closed.

### Initialization and learning of sunroof



1. Both sunroof and sunshade are not initialized.
  - Continuously press forward the sunroof switch ① or the sunshade closing switch ②.
  - The sunroof moves to the fully closed position with sunshade still, and then, close the sunroof by operating the sunroof switch to complete initialization.
  - With sunroof still, make the sunshade move to the fully closed position to complete initialization.
  - Release sunroof switch ① and the sunshade closing switch ② to end the initialization of sunroof and sunshade.

## 4. Operation of systems and equipment

2. The sunroof is initialized, but the sunshade is not initialized.
  - Press and hold the sunshade closing switch ②.
  - The sunshade does not move, the sunroof moves to the fully closed position and then stops, and the sunshade moves to the fully closed position.
  - The sunroof does not move, and the sunshade first moves to the fully open position and finally moves to the fully closed position.
  - Release the sunshade closing switch ② to end the sunshade initialization.



### CAUTION

If the power window system fails, please go to the GAC Motor authorized shop for inspection in time.

### 4.2.9 Basic operation of body anti-theft system

#### Body anti-theft function - remote control unlocking

When the ignition is in the “OFF” position and the vehicle is in the anti-theft state, if you bring the intelligent remote control key to approach the vehicle doors and press the UNLOCK button on the remote control key, all the doors will be unlocked to release the vehicle from the anti-theft state, and the turn signal lamps will flash twice.

#### Body anti-theft function - remote control locking

When the ignition is in the “OFF” position and the four doors, engine hood and liftgate are closed, if you take the intelligent remote control key away from the vehicle and press the locking button on the remote control key, all the doors will be locked to enable the vehicle to enter the anti-theft state, and the turn signal lamps will flash once.

#### Activation of body anti-theft function

When the ENGINE START/STOP button is in “OFF” position and the vehicle is armed, if the door is unlocked by an illegal key or is forcibly unlocked, the anti-theft system will be activated, the anti-theft horn will sound and the turn signal lamps will flash.

When the vehicle is locked by remote control and enters the anti-theft state, if the driver’s door is unlocked with the emergency mechanical key, the anti-theft system will trigger the horn to sound and the turn signal lamps will flash.



### NOTE

Before or during the anti-theft alarm is triggered, if you press the button  on the remote control key or switch the ignition to the “ON” position, the anti-theft alarm will be disabled and the vehicle will be released from the anti-theft state; the alarm can be triggered up to 10 times in one cycle.



### Engine immobilizer

When the ignition is switched from the "OFF" position to the "ON" position with the body anti-theft state released and the legal key in the vehicle, if the engine immobilizer system passes the verification, it will be deactivated.

If the engine immobilizer system does not pass the verification, the engine cannot be started and an immobilizer alarm will be triggered.

### Body anti-theft maintenance instructions

No maintenance is required during normal use. If you have any doubt, please contact the GAC Motor authorized shop.

## 4.3 Lamps and vision

### 4.3.1 Exterior lamps

#### Lamplight combination switch



- ① Lamp switch
- ② Fog lamp switch

### i NOTE

- Water vapors or even water drops may appear on the inner surfaces of the lamps under certain conditions (such as high air humidity and after vehicle washing), which is similar to the fogging phenomenon on the windows when the vehicle is traveling in the rain, and does not constitute a malfunction.
- This fogging phenomenon can be eliminated by parking the vehicle in a dry environment, turning on the lamps or driving the vehicle, but may recur.
- If there are a lot of water drops or water ingress in the lamps, please contact the GAC Motor authorized shop for inspection.

## 4. Operation of systems and equipment

### Turn signal lamp

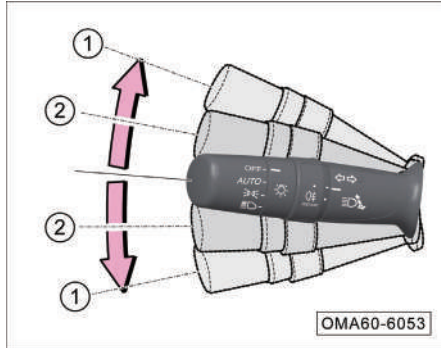

- When the ignition is in the "ON" position, if you turn the lamplight combination switch up or down to the limit position ①, the right or left turn signal lamp will go on, and the corresponding indicator lamp ➡ or ⬅ on the instrument cluster will flash.

### Turn signal lamp flashing for lane change

- In case of lane changing or overtaking, if you quickly turn the lamplight combination switch up or down to the position ② and then release it to the original position, the corresponding turn signal lamp and the indicator lamp ➡ or ⬅ on the instrument cluster will flash 3 times.

- If you turn the lamplight combination switch up or down and hold it at the position ②, the corresponding turn signal lamp and the indicator lamp ➡ or ⬅ on the instrument cluster will flash continuously. Releasing the switch to the original position can stop the flashing.

### CAUTION

If the corresponding indicator lamp ➡ or ⬅ on the instrument cluster flashes at the doubled frequency, one of the turn signal lamps may be faulty, and in this case, please go to the GAC Motor authorized shop for inspection in time.

### Lamp switch

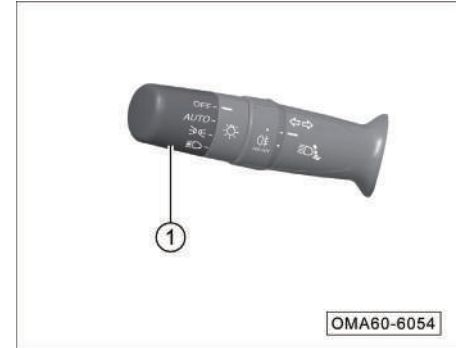

When the ignition is in the "ON" position, turn the lamplight control switch ① to turn on or off AUTO (automatic headlamp on/off function), 36 (position lamp), and 36 (low beam).

When the lamplight switch is turned to the "OFF" position, all lamps will go out.

## 4. Operation of systems and equipment

AUTO (automatic headlamp on/off function)

- Turn the lamplight control switch to the AUTO position to activate the automatic headlamp on/off function.

### NOTE

If the automatic headlamp on/off function is activated, the vehicle will automatically turn on or off the headlamp according to the ambient light. When the ambient light gradually becomes dark, the position lamps and the low beam will be turned on simultaneously; when the ambient light gradually becomes bright, the position lamps and the low beam will be turned off simultaneously.



### CAUTION

- If the instrument cluster displays “Sensor Failure, Please Manually Control Light”, the system will keep the low beam on for the sake of safety. At this time, you should manually control the light and go to the GAC Motor authorized shop for inspection in time.
- The automatic headlamp on/off function may be affected in the haze environment, so please manually turn on the headlamp in this case.

Daytime running lamp\*

- When the engine is started and the position lamps are off, the daytime running lamps will be automatically turned on; when the low beam are turned on or the engine is shut down, the daytime running lamps will be automatically turned off .

Position lamp

- If you turn the lamplight control switch to the position , the position lamps, instrument panel light, license plate lamps and other lamps will be turned on, and the corresponding indicator lamp  on the instrument cluster will come on.

## 4. Operation of systems and equipment

### NOTE

If you forget to turn off the position lamps when the ignition is switched to the "OFF" position and the vehicle is not locked, the position lamps will stay on for 15 min and then go out automatically in order to save the battery power; when the ignition is switched to the "OFF" position and the vehicle is locked, the position lamps will go out immediately.

### WARNING

- **When driving the vehicle at night or on a road with poor visibility, also use other lamps in addition to the position lamp. Otherwise, accidents may easily occur.**
- **When temporarily parking the vehicle at night or on a road with poor visibility with the need of indicating the position of the vehicle, do not use the position lamps as the parking lamps but be sure to turn on the hazard warning lamp due to the battery power saving function of the position lamps.**

#### Low beam

- Turn the lamplight control switch to the  position to turn on the low beam.

#### High beam

- After turning on the low beam, if you push the lamplight combination switch forward to the limit position, the high beam will be turned on and the corresponding indicator lamp  on the instrument cluster will come on.
- If you pull the lamplight combination switch backward to the original position, the high beam will be turned off.

#### Headlamp flashing

- If you pull the lamplight combination switch backward to the limit position, the high beam will be turned on.
- If you release the switch, the lamplight combination switch will automatically return to its original position and the high beam will be turned off.

### NOTE

- The high beam may cause dazzling to drivers of oncoming vehicles at close range and possibly result in an accident thereafter. Therefore, please use the high beam reasonably.
- When all the lamps are turned off, if you pull and hold the lamplight combination switch backward, the high beam will stay on, and the corresponding indicator lamp  on the instrument cluster will come on.

## 4. Operation of systems and equipment

### Headlamp leveling knob\*

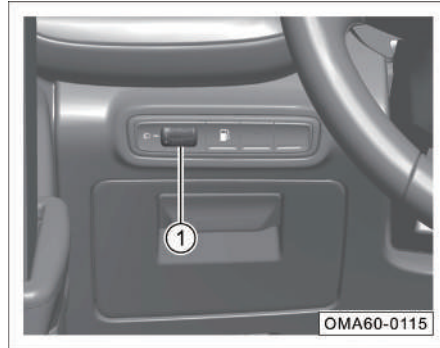

Rotate the knob ① to manually adjust the beam level of headlamp (low beam) to position 0, 1, 2 or 3. The level of the headlamp will decrease as the adjustment value increases.

### Position lamp on warning

When the ignition is turned to the "OFF" position with the position lamps on, if you open the driver's door, the system will send a buzzer sound and the instrument cluster display will display the message "Lamp On".



### Follow Me Home

Within 10 minutes after switching the ignition to the "OFF" position, if you turn the lamplight control switch from the "OFF" position to other positions and then back to the "OFF" position within 2 s, the headlamp delay off function will be activated. In this case, the low beam will stay on for 30 s, if one of the doors (including four doors, engine hood and liftgate) is opened within this 30 s, this function will be re-timed, and then the low beam will stay on for 80 s, and if all the doors are closed within this 80, this function will be re-timed again, and then the low beam will stay on for 30 s.

### Fog lamp switch





When the ignition is in the "ON" position with the position lamp or low beam turned on, turn the fog lamp switch ② to turn on or off the  (rear fog lamp).

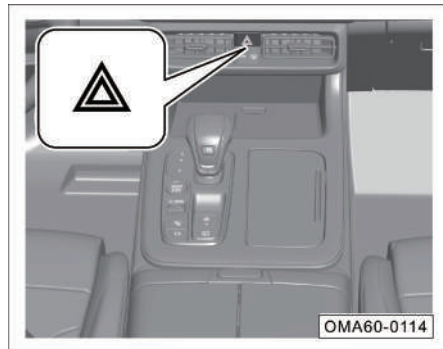

- After the fog lamp switch ② is turned to the position  and then released to the position "-", the rear fog lamp will come on.
- When the fog lamp switch ② is turned to position  again and then released to return to position "-", the rear fog lamp will go out.

## 4. Operation of systems and equipment

### Hazard warning lamp



If you press the switch  with ignition in any position, the red indicator lamp on the switch will flash and the hazard warning lamp will be turned on. Press this switch again to turn off the hazard warning lamp.

If the hazard warning lamp is turned on, all turn signal lamps and the indicator lamps  and  on the instrument cluster will flash simultaneously.



The hazard warning lamp shall be turned on in the following cases so as to attract the attention of persons on the road and reduce the risk of traffic accidents:

- The vehicle is involved in any failure.
- The vehicle is at the tail end of a traffic jam.
- The vehicle tows another vehicle or is towed.
- The vehicle is temporarily parked due to poor visibility.

### NOTE

- The use of the hazard warning lamp will consume the battery power, so please turn it off when not in use.
- Be sure to strictly abide by the relevant regulations when using the hazard warning lamp.
- In the event of an emergency, if the hazard warning lamp is faulty, other methods that comply with the relevant traffic rules and regulations must be taken to attract the attention of persons on the road.

### Vehicle assisted lighting

- If you press the unlocking button  on the remote control key within the effective range, the position lamps will stay on for 25 s for the purpose of helping you to approach your vehicle. If you press the unlocking button  on the remote control key again, the position lamps can stay on for another 25 s. When you get in the vehicle and switch the ignition to the "ON" position, the position lamps will go out.

### Vehicle locating lighting

- If you press the locking button  on the remote control key twice within 0.5 s, the position lamps will stay on for 8 s and the turn signal lamps will flash 3 times for the purpose of helping you to locate your vehicle.

## 4. Operation of systems and equipment

### Intelligent courtesy lamp\*

When all the doors are closed and locked with IGN OFF, the user can unlock/lock the door by any one of the following methods to trigger the headlamp courtesy function, when the position lamps and courtesy lamps will be on for 30s:

- Unlocking/locking by intelligent remote control key.
- Unlocking/locking by mechanical key.
- Unlocking by approaching the vehicle with intelligent key in hand.
- Locking by walking away from the vehicle.
- Automatic locking when no door is opened within 30s after the vehicle is unlocked.

#### **i** NOTE

The intelligent courtesy lamp can be activated or deactivated by selecting "Settings → Body Accessories → Exterior Light → Intelligent Courtesy Lamp", and then clicking the soft key  on the AV system display.

### Light show control\*

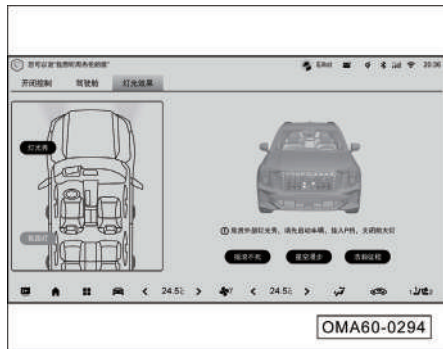

Click "My Car" soft key in the AV system application menu interface to enter My Car interface, and click "Lighting Effect" soft key to select "Rock Steady", "Star Walk" or "Vast Journey".

#### **i** NOTE

Start the vehicle first, set the gearshift lever to "P" position, turn off the headlamps, click the light show function switch, and enjoy the external light show.

### 4.3.2 Interior amp

#### Automatic light-on function of dome lamps



- Press the switch ① (depressed) to deactivate the automatic light-on function of dome lamps; press the switch ① (popping up) again to activate this function.

## 4. Operation of systems and equipment

### Interior light delay off

When the dome lamps are off and the automatic light-on function of dome lamps is activated:

- If the ignition is in the "OFF" position and one of the doors is opened, the dome lamps will come on automatically, and then go out about 30 s after the doors are closed.
- If the ignition is in the "OFF" position and the doors are unlocked by remote control, the dome lamps will come on automatically and then go out after about 30 s.
- If the ignition is switched from the "ON" position to the "OFF" position, the dome lamps will come on automatically and then go out after about 30 s.

#### **i** NOTE

When all the doors are closed and the dome lamps are on as mentioned above, if the vehicle is locked by remote control or the ignition is switched to the "ON" position, the dome lamps will go out automatically.

### Dome lamp



- When the dome lamps are off, press the switch ② (depressed) to turn on all the dome lamps; press the switch ② (popping up) again to turn off all the dome lamps.

#### **i** NOTE

The switch ② will be ineffective if it is not used to turn on the front dome lamps.



- When the front dome lamps are off, press the switch ③ (depressed) to turn on the front dome lamp on the corresponding side; press the switch ③ (popping up) again to turn it off.

#### **i** NOTE

The switch ③ will be ineffective if it is not used to turn on the front dome lamps.



## 4. Operation of systems and equipment

### Second-row dome lamp

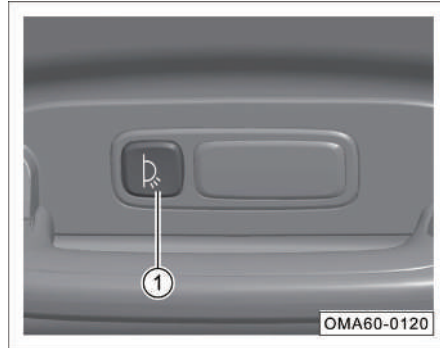

- When the second-row dome lamps are off, press the switch ① to turn on the dome lamp on the corresponding side; press the switch ① again to turn it off.

#### **i** NOTE

The switch ① will be ineffective if it is not used to turn on the second-row dome lamps.

### Third-row dome lamp



- When the third-row dome lamp is off, press the end ㄱ or end O of the selection button to turn on/off the third-row dome lamp.
- When the third-row dome lamp switch is in the flat state, i.e. in the position ㄱ, the third-row dome lamp can be turned on by opening the door or pressing the front dome lamp switch.

### Glove box lamp\*

- If the glove box is opened, the glove box lamp will come on automatically.
- If the glove box is closed, the glove box lamp will go out automatically.

### Trunk lamp

- If the liftgate is opened, the trunk lamp will come on automatically.
- If the liftgate is closed, the trunk lamp will go out automatically.

### Cigarette lighter light

- If the position lamp is turned on, the cigarette lighter light will come on automatically.
- If the position lamp is turned off, the cigarette lighter light will go out automatically.

### Vanity mirror lamp

- If the vanity mirror cover is opened, the vanity mirror lamp will come on automatically.

## 4. Operation of systems and equipment

- If the vanity mirror cover is closed, the vanity mirror lamp will go out automatically.

### Smart ambient light\*

Click on the 3D vehicle model in the main interface of AV system or the “My Car” soft key in the application interface to enter the My Car interface, and then select “Light Effect→Ambient Light” soft key to enter the interior ambient light effect setting interface.

Operation interface:

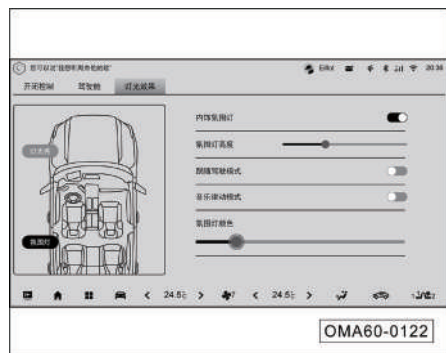

1. Ambient light switch
  - Click the interior ambient light soft key to activate/deactivate the ambient light function.
  - When the ambient light function is deactivated, other parameters cannot be adjusted; when the ambient light function is activated with IGN ON, the ambient light stays on.
2. Ambient light brightness adjustment
  - Users can adjust the brightness of ambient light by clicking or sliding the ambient light brightness progress bar among 8 levels as desired.
3. Drive mode following switch
  - When the drive mode following function is activated, the color of the ambient light will change along with the drive mode. That is to say, when the user changes the drive mode, the ambient light color will change accordingly.
4. Music rhythm mode
  - If the music rhythm mode is activated, the ambient light brightness will change along with the music rhythm when the music is played.
5. Ambient light color
  - Users can select the ambient light color by dragging or clicking on the color bar.

### 4.3.3 Wiper combination switch

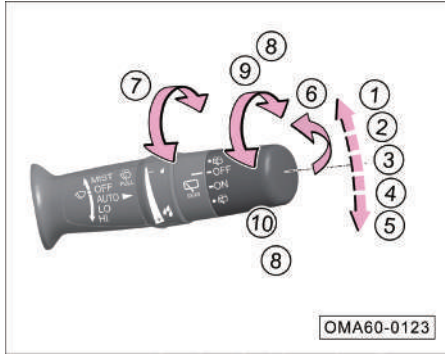

When the ignition is in the “ON” position, the wiper combination switch can be operated as follows:

- ① MIST: continuous wiping
- ② OFF: front windshield wiper off
- ③ AUTO: automatic wiping
- ④ LO: wiping at low speed
- ⑤ HI: wiping at high speed
- ⑥ front windshield washer system on
- ⑦ automatic wipe sensitivity adjustment knob

- ⑧ : rear windshield washer system on
- ⑨ OFF: rear windshield washer or wiper off
- ⑩ ON: rear wiper on

#### MIST: continuous wiping

- If the wiper combination switch is turned to the MIST position ①, the front wiper will start wiping continuously.
- If the wiper combination switch is released to automatically return to the OFF position ②, the front wiper will stop wiping.

#### OFF: wiper off

- If the wiper combination switch is turned to the OFF position ②, the front wiper will stop wiping.

#### AUTO: automatic wiping

- If the wiper combination switch is turned to the AUTO position ③, the automatic wiping function will be activated, and the wiper system will adjust the wiper speed according to the current rainfall and the real-time vehicle speed.
- Adjust the wiping sensitivity by turning the knob / ⑦ up/down.

- This function can be activated or deactivated by selecting “Settings → Body Accessories → Other Accessories → Auto Wiping” on the A/V system display.

#### CAUTION

- If the instrument cluster displays “Sensor Failure, Please Manually Control Wiper”, for the sake of safety, you should manually control the wiper and go to the GAC Motor authorized shop for inspection in time.
- Before activating the automatic wiping function in winter, please check whether the wiper blade is frozen.
- It is recommended to deactivate the automatic wiping function when washing the vehicle, in dusty weather and in rainless weather to avoid unintentional action of the wipers which may cause damage or personal injury.
- The automatic wiping function is an assist, so the driver should manually operate the wipers when necessary according to the driving situation to ensure driving safety.

## 4. Operation of systems and equipment

---

### LO: slow speed wiping

- If the wiper combination switch is turned to the LO position (4), the front wiper will wipe at a slow speed.

### HI: high speed wiping

- If the wiper combination switch is turned to the HI position (5), the front wiper will wipe at a high speed.

### Front windshield washer system on

- If the wiper combination switch is turned toward the rear of the vehicle to the (6) position, the front washer will start spraying water and then the front wiper will start wiping.
- If the wiper combination switch is released to return to its original position, the front windshield washer system will be turned off.
- After the front wiper stops wiping for 6 s, it will wipe once again so as to clear the residual water stains from the glass.

### Rear windshield washer system on

- If you turn the rear wiper knob up/down to the limit position (8) with liftgate closed, the washer will start spraying water and then the rear wiper will start wiping.
- After the front wiper stops wiping for 6 s, it will wipe once again so as to clear the residual water stains from the glass.

### ON: rear wiper on

- When the liftgate is closed, if you turn the rear wiper knob to the ON position (10), the rear wiper will start wiping.
- Reverse Link: When the liftgate is closed and the front wiper is turned on, moving the shift lever to R will operate the rear wiper.

### OFF: Rear windshield washer or rear wiper off

- If you turn the rear wiper knob to the OFF position (9), the rear windshield washer system will be turned off or the rear wiper will stop wiping.

### Front wiper maintenance

- When the wiper switch is in the "OFF" position, the wiper can be set to the high position by clicking the "Wiper Maintenance Mode" soft key on the right side in the "Settings → Body Accessories → Other Accessories" interface on the AV system display, and can be moved to the original position by clicking the soft key.

### Voice control of wiper system

With IGN ON, the wiper system can be controlled by voice:

- Control the front wiper to run at low speed or high speed by voice command.
- Control the rear wiper to work by voice command.
- The front washer will be on for 3s and then turned off automatically each time it is turned on by voice control.
- The rear washer will be on for 3s and then turned off automatically each time it is turned on by voice control.

### 4.3.4 Windshield

#### Windshield glass



The green sound-insulation and laminated anti-scattering glass is used for the front windshield, which can effectively reduce the personal injury in an accident.

#### WARNING

- Always keep the glass surface clean.
- Please affix the necessary identifications according to local traffic laws, rules and regulations. Do not stick paper or hang objects on the surface of the front windshield glass, otherwise the front view will be obstructed, which may easily cause traffic accidents.

### 4.3.5 Rearview mirror

#### Interior rearview mirror

Automatic anti-dazzling interior rearview mirror

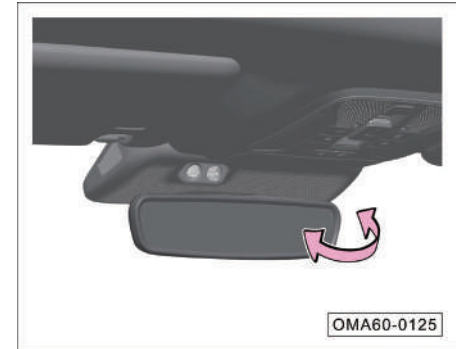

Automatic anti-dazzling interior rearview mirror will monitor the intensity of light from the rear traffic in real time and automatically adjust the mirror reflection effect accordingly so as to soften the strong light to be reflected into the driver's eyes.

- Before driving, be sure to adjust the interior rearview mirror to the appropriate angle.
- Hold the interior rearview mirror and adjust it up and down and left and right to the best rearview position.

## 4. Operation of systems and equipment

### CAUTION

Do not adjust the rearview mirror during driving, as you will be distracted from driving, causing loss of control to vehicle and dangerous accident thereafter.

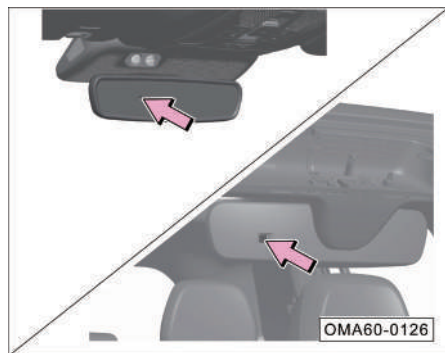

### CAUTION

To ensure the normal function of the sensor for anti-dazzling rearview mirror, do not cover the sensor (indicated by the arrow) with your finger or cloth.

### Exterior rearview mirror

### WARNING

Although the curved (convex and spherical) rearview mirror can expand the field of view, the reflected object image is smaller and farther than the real object. Therefore, when changing the lanes, do not judge the distance between your vehicle and the following vehicle by the reflected image, otherwise accidents may occur due to wrong judgment.

### i NOTE

If the function of the exterior rearview mirror fails, please go to the GAC Motor authorized shop for inspection in time.

### Electric adjustment

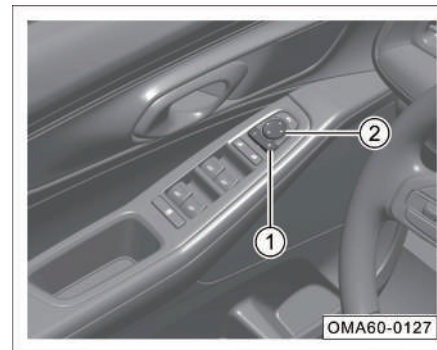

- Press “L” or “R” end on the selection button ① to select the left or right exterior rearview mirror.
- Press the adjusting button ② to adjust the selected exterior rearview mirror to the appropriate rearview angle.
- After adjusting the exterior rearview mirror, restore the selection button ① to its original state.

## 4. Operation of systems and equipment

### Electric folding

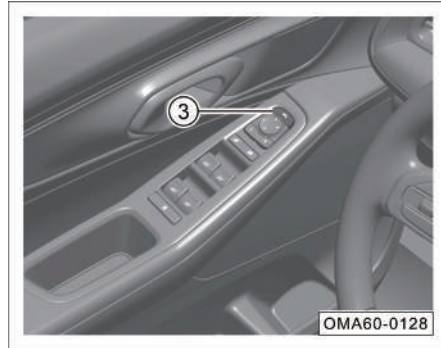

- Press the folding button ③ to fold the exterior rearview mirror electrically.
- Press the folding button ③ again to unfold the exterior rearview mirror electrically.

### Automatic folding

- If the vehicle is locked from outside, the exterior rearview mirror will be folded automatically.
- If the vehicle is unlocked from outside, the exterior rearview mirror will be unfolded automatically.

### NOTE

This function can be activated or deactivated by selecting “Settings → Body Accessories → Other Accessories → Auto Folding of Exterior rearview Mirror” on the AV system display.

### CAUTION

- If the electric folding function fails, the mirror can be manually folded, and if the mirror is manually folded, manual unfolding is required when necessary. A click sound can be heard when the mirror is manually unfolded.
- Be careful when operating the electric folding function of the exterior rearview mirror to prevent your fingers from being pinched by the rearview mirror and its base.

### Reverse tilt-down\*

Memory of reverse tilt-down position of exterior rearview mirror is as follows:

1. Manual memory of reverse tilt-down position of exterior rearview mirror:
  - With IGN ON, select “Settings → Body Accessories → Other Accessories” on the AV system display, and then activate the “Reverse Tilt-down” function.
  - Depress the brake pedal and move the shift lever to R.
  - Adjust the corresponding exterior rearview mirror to a suitable position for reversing. After the adjustment, release the brake pedal, and then this position is memorized as the tilt-down position of exterior rearview mirror when reversing.
2. Automatic memory of reverse tilt-down position of exterior rearview mirror:
  - With IGN ON, select “Settings → Body Accessories → Other Accessories” on the AV system display, and then activate the “Reverse Tilt-down” function.

## 4. Operation of systems and equipment

- Click the “Setting” soft key for automatic angle adjustment of exterior rearview mirror to adjust the exterior rearview mirrors on both sides to suitable positions for reversing. After the adjustment, click the “OK” soft key, and then this position is memorized as the tilt-down position of exterior rearview mirror when reversing.

The reverse tilt-down function is only a reverse assistance function for users, and is off by default; users can switch on the reverse tilt-down function and set the reverse tilt-down position by selecting “Settings → Body Accessories → Other Accessories → Reverse Tilt-down\*” on the AV system display. When you move the shift lever to R, the rearview mirrors on both sides will tilt down, and when you shift out of the “R” position, the mirror will automatically return to the original position. If the reverse tilt-down function is switched off, the rearview mirror will not tilt down when you move the shift lever to R.

### 4.3.6 Sun visor

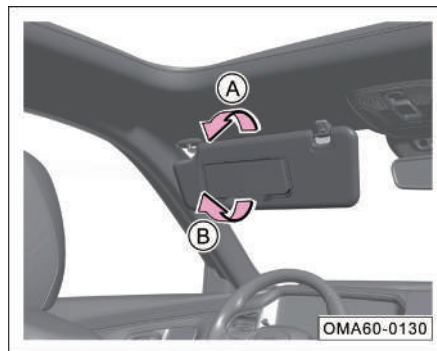

- Turn down the sun visor on the driver's side or front passenger's side in the direction of arrow A to shelter from the incoming sunlight from the front windshield.
- To use the vanity mirror, flip down the sun visor and pull open the vanity mirror cover in the direction of arrow B, and then the vanity mirror lamp \* comes on automatically.

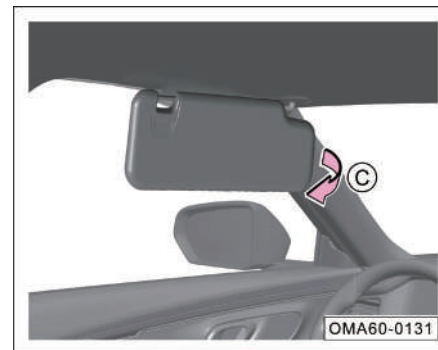

- After turning down the sun visor on the driver's side or front passenger's side, pull it out from the movable bracket in the direction of arrow C to shelter from the incoming sunlight from the side window.

#### **i** NOTE

If the vanity mirror cover is opened, the vanity mirror lamp will go out automatically a few minutes after the ignition is switched to the “OFF” position or the vehicle is locked.



### 4.4 Seats and storage facilities

#### 4.4.1 Headrest

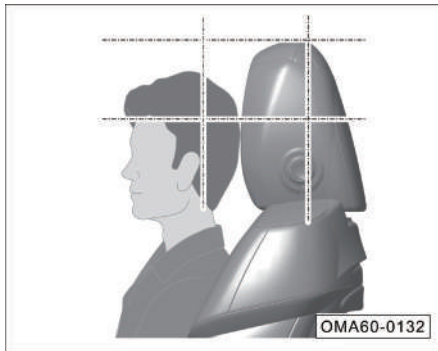

Correct adjustment of the headrests is essential to protect the occupants and reduce the personal injuries in accidents.

Always adjust the head restraint to the correct position (as shown in the figure) according to their body shape.

#### WARNING

In order to reduce the risk of accidental casualties, please strictly observe the followings:

- Do not adjust the headrest while driving.
- Always keep the head restraint in its installation position. If the headrest is removed or installed improperly, the driver may be seriously injured in an accident.

Height adjustment of front passenger's head restraint (for manual adjustment of four-way head restraint)\*

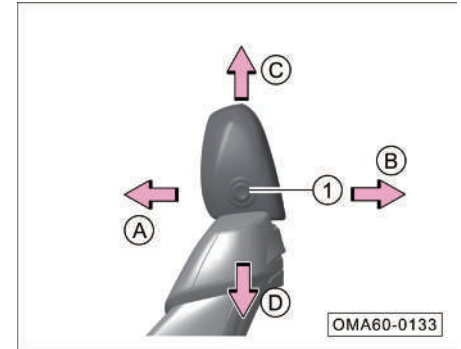

Forward and backward adjustment of head restraint

- Press and hold the lock button ① and push the head restraint in the direction of arrow A or B to move the head restraint forward or backward.

Upward and downward adjustment of head restraint

- Upward adjustment: Lift up the head restraint directly to the desired position in the direction of arrow C.
- Downward adjustment: Press and hold the lock button ①, and press down the head restraint to the desired position in the direction of arrow D.

## 4. Operation of systems and equipment

### Height adjustment of front passenger's head restraint (for manual adjustment of two-way head restraint)\*



- Downward adjustment: Press and hold the lock button ①, and press down the head restraint to the desired position.
- Upward adjustment: Lift up the head restraint directly to the desired position.

#### **i** NOTE

The adjustment method of second-row head restraints is the same as that of third-row head restraints\*.

### 4.4.2 Front seats

#### **i** NOTE

When measuring the depth of the seat cushion, be sure to adjust the front and rear positions of the seat to the middle of the slide rail and the seat back to the normal operating state (25°).

#### **⚠** WARNING

- **Do not place objects under the front seats, for these objects may be caught between the seat and the slider rail, hindering the seat from being locked.**
- **Do not adjust the seats when the vehicle is traveling as this is likely to cause casualties. Therefore, please adjust the front seat only when the vehicle is in a stationary state.**
- **Never leave children alone in the vehicle, because the power seat\* adjustment mechanism still works after the ignition is switched to the "OFF" position, and if the children accidentally operate the power seat, it may cause an accident.**

### Power seat

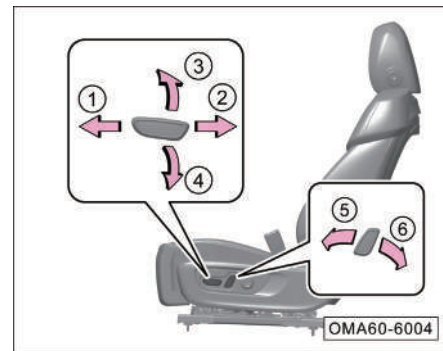

Forward and backward adjustment of seat:

- Push the switch in the direction of arrow ① or ② to adjust the seat to slide forward or backward.

Upward and downward adjustment of seat (for driver's seat):

- Pull the switch in the direction of arrow ③ or ④ to adjust the seat upward or downward.

Upward and downward adjustment of front end of seat cushion (for driver's seat)\*:

- Pull the switch in the direction of arrow ⑤ or ⑥ to adjust the front end of the seat cushion upward or downward.

## 4. Operation of systems and equipment

### Adjustment of driver's seat lumbar support\*



- Press the switch in the direction of arrow ① or ② to extend or retract the lumbar support.

### Seat ventilation \*

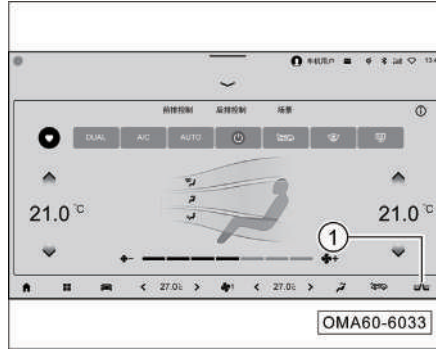

Set the ENGINE START/STOP button to "ON" position, and click the seat ventilation icon at the bottom ① of the main interface of the AV system to show the seat ventilation interface.

### Ventilation

- When you click "Ventilation", the seat ventilator will work in the 3rd ventilation level by default, and you can click the key 1/2/3 to adjust the heater to the desired ventilation level.
- The seat ventilator has three ventilation positions, among which the 3rd position has the highest fan speed followed by the 2nd position, and the 1st position has the lowest fan speed.

### Intelligence

- Click "Intelligent" to turn on the intelligent seat ventilation mode.

### Off

- Click "OFF" to turn off the seat ventilation function.

### **i** NOTE

When the ENGINE START/STOP button is in "ON" position and the AV system is turned on normally, you can control the seat ventilation level by voice.

## 4. Operation of systems and equipment



### CAUTION

- Do not kneel on the seat or apply pressure to a point on the seat cushion or seat back, so as to avoid damaging the electrical components in the seat.
- If the seat fan is found failing to work after the seat ventilation function is turned on, please turn off the seat ventilation function immediately and go to the GAC Motor authorized shop for inspection in time.

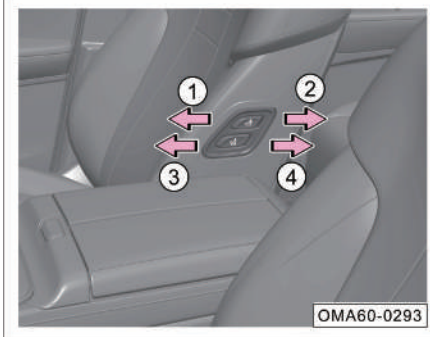
### Adjustment of front passenger's seat rear adjusting switch\*



Forward and backward adjustment of seat:

- Press the switch  in the direction of arrow ① or ② to adjust the seat back of the front passenger's seat forward or backward.
- Press the switch  in the direction of arrow ③ or ④ to adjust the front passenger's seat forward or backward.

### NOTE

- When the driver's seating position is manually adjusted, a message will pop up on the AV system interface to prompt the driver to save the new position or restore the previously saved position (if such saving or restoring are not required, ignore this prompt message), and if such saving is necessary, confirm the saving to update the seating position.
- The power seat cannot be adjusted within 5 seconds after a collision.

### WARNING

- **Do not adjust the seat during driving, otherwise accidents may occur due to distraction caused by seat movement.**
- **When the power seat control unit or the driver's power seat is replaced or the driver's seat frame is repaired, the memory seating position must be cleared, otherwise the driver and passenger may be pinched and injured thereafter.**

### 4.4.3 Second/third-row seat

#### 2nd-row seats adjustment

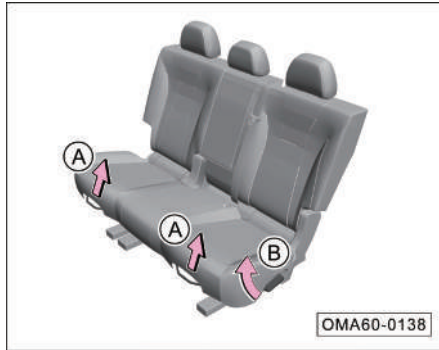

Forward and backward adjustment of seat:

- Pull the adjusting handle in the direction of arrow A to adjust the seat forward or backward. Then release the adjusting handle, and slide the seat forward or backward slightly until the seat is firmly locked.

Forward and backward adjustment of seat back:

- Pull up the adjusting handle in the direction of arrow B to adjust the seat back to a desired position, and then release the handle, and confirm that the seat back is locked securely.

#### Electric folding of 2nd-row seat back \*

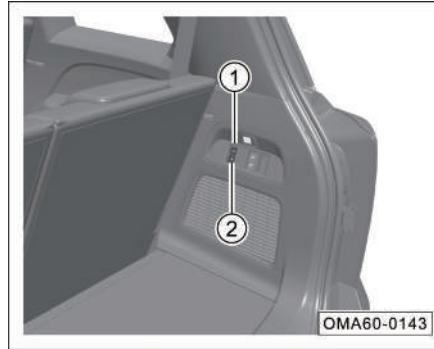

Press buttons ① and ② to electrically fold the 2nd-row seat backs. After folding, you need to manually reset the seat backs to the appropriate position and confirm that the seat backs are locked firmly.

#### Second-row central armrest



- Turn down the central armrest forward to use it.

#### **i** NOTE

The central armrest shall not be seated by anyone, and shall be stowed to the seat back if the seating position needs to be used.

## 4. Operation of systems and equipment

### Manual adjustment of 3rd-row seat back \*

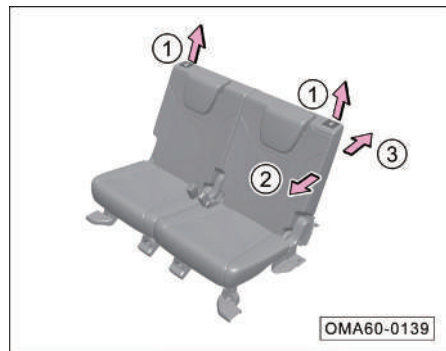

- Pull the adjusting handle in the direction of arrow ①.
- Push the seat back to the desired position in the direction of arrow ② or ③, and then, release the adjusting handle, and confirm that the seat back is properly locked.

### Electric adjustment of 3rd-row seat back \*

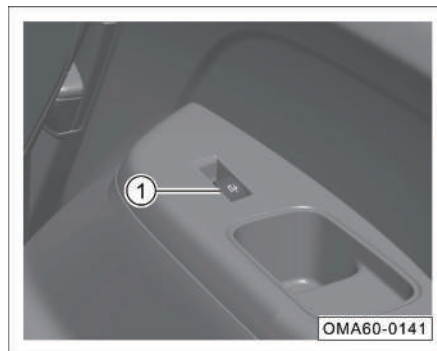

- Lift the button ①, adjust the 3rd-row right seat back backward to the appropriate position, and then release the button.
- Press the button ①, adjust the 3rd-row right seat back forward to the appropriate position, and then release the button.

### Accessing to third-row seat



- Press the switch on the shoulder of the second-row seat back as arrowed to fold the seat back, and then unlock the slide rail to slide the right seat forward, so that the occupants of third-row seat can enter or exit smoothly.
- Restore the seat back to the normal seating state and push the seat back until both the slide rail and the seat back are locked into position. Before driving, confirm that the seat back and slide rail are locked firmly.

## 4. Operation of systems and equipment

### Manual folding/reset of 3rd-row seat \*

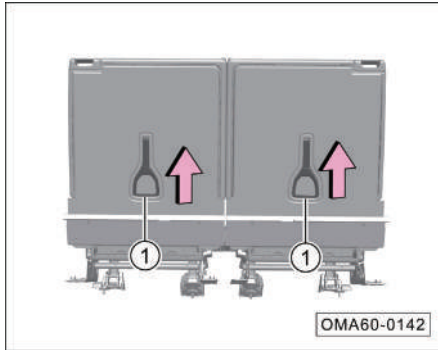

- Adjust the head restraint of the third-row seat to the lowest position.
- Pull the handle ① to manually fold the third-row seat. When necessary, return the handle ① to the original position, and confirm that the seat is locked securely.

### Electric folding/reset of 3rd-row seat \*

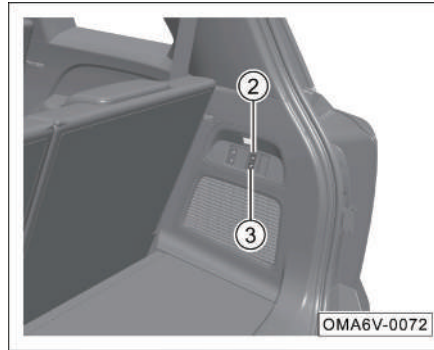

- Adjust the head restraint of the third-row seat to the lowest position.
- Press the buttons ② and ③ to electrically fold the 3rd-row seats, and lift the buttons ② and ③ to electrically reset the 3rd-row seats.

### 4.4.4 Storage facilities

#### Storage compartment on door interior trim panel



- Place beverage bottles, map manuals and other articles here.

## 4. Operation of systems and equipment

### Storage box on lower guard plate of cab



- Open the storage box on lower protective plate of cab as arrowed to place small articles.
- Push back to close the storage box until a “click” is heard.

### Cup holder

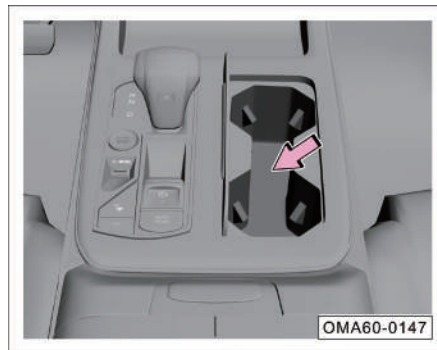

- Front cup holder: Press to open the front cup holder cover automatically and place beverage bottles.

### Second-row cup holder



- Rear cup holder: Turn down the central armrest forward and then place beverage bottles.

### WARNING

**Do not place hot beverages on the cup holder, or hot beverages may spill out when the vehicle is running, causing scalding passengers.**



## 4. Operation of systems and equipment

### Third-row cup holder

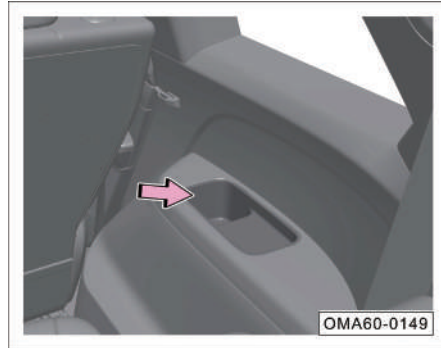

- For placing beverage bottles.

### Spectacle case

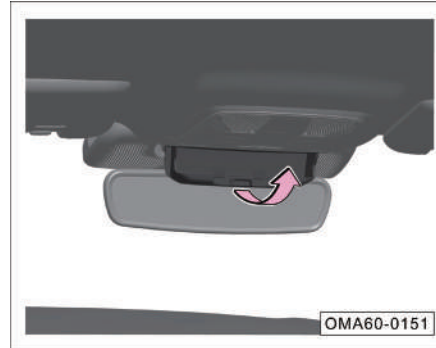

- Press to slowly open the spectacle case and place small articles such as sunglasses.
- Push back to close the spectacle case until a "click" is heard.

### Instrument panel front storage compartment



- Place small articles here.

### **i** NOTE

For models equipped with mobile phone wireless charging function, this area is used as the mobile phone wireless charging area, so be sure to deactivate the mobile phone wireless charging function before placing articles in it. => See page 103

## 4. Operation of systems and equipment

Front central armrest box

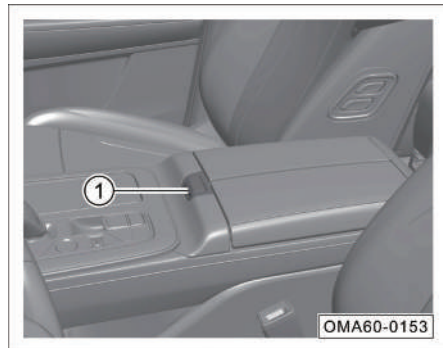

- Press the switch ① to open the front center console armrest box cover and place wallets and other articles.

Storage compartment on the back of front center console armrest box\*



- Place small articles here.

Storage bag on the back of front seat

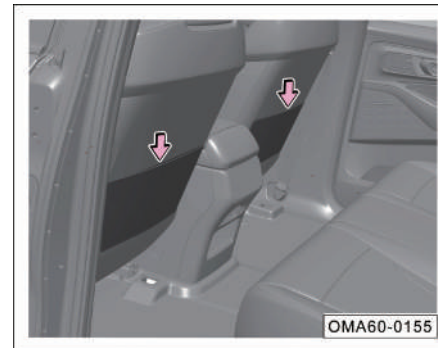

- Pull open the storage bag to put books, foldable umbrellas and other articles in it.

## 4. Operation of systems and equipment

### Front passenger's glove box

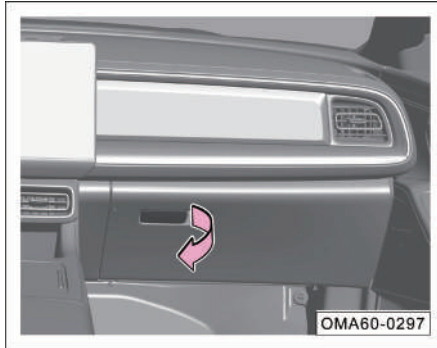

- Pull the handle to open the glove box for placing articles such as file bags.
- Push back to close the glove box until a “click” is heard.

#### WARNING

**The glove box must be closed when the vehicle is traveling, otherwise the articles in the glove box may fly out and cause personal injury to the occupants in case of an emergency braking or an accident.**

### 4.4.5 Power outlet/USB port

#### Front 12V power outlet



- With the ENGINE START/STOP button in “ACC” or “ON” position, the power outlet can be used once the plug cap is pulled out.

#### USB charging port on the back of front center console armrest box



- With the ignition in the “ACC” or “ON” position, a device to be charged can be connected directly for charging.

#### NOTE

The rear USB port is for charging only.

## 4. Operation of systems and equipment

### Front USB port

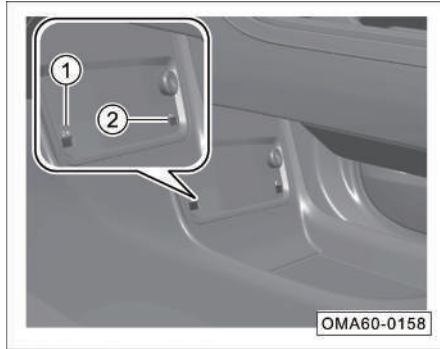

- With the ignition in the “ACC” or “ON” position, a mobile device can be connected directly for use.

#### **i** NOTE

- USB1 port ① supports the charging, media source playback and OTG functions.
- USB2 port ② supports charging and media playback.

### Trunk power outlet

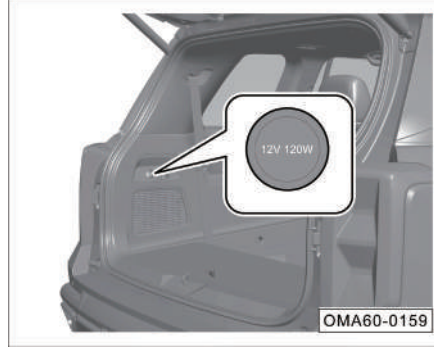

- With the ignition in the “ACC” or “ON” position, after the rear power outlet cover plate is opened, a device to be charged can be connected.

#### **i** NOTE

Devices up to 12V/120W are supported.

### USB interface at interior rearview mirror \*

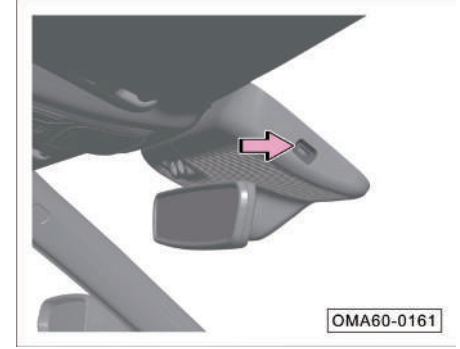

- With the ignition in the “ACC” or “ON” position, a device can be connected directly for use.

## 4. Operation of systems and equipment

### 4.4.6 Mobile phone wireless charging system\*

The mobile phone wireless charging system utilizes electromagnetic induction to realize the charging of the mobile phone without the need for wire connections.

#### CAUTION

The mobile phone wireless charging system is only suitable for the Qi-certified mobile phones. GAC will not assume liabilities and losses for any accident caused by the use of mobile phones or other wireless charging receivers that have not passed the “Qi” certification.

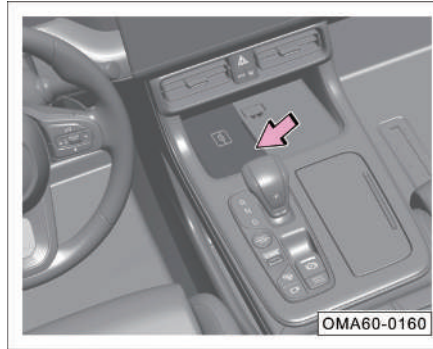

The wireless charging effective zone is in the storage slot in front of the shift lever. To charge the mobile phone, please align its charging coil with the “Qi” logo to ensure the normal charging.

### Mobile phone wireless charging switch

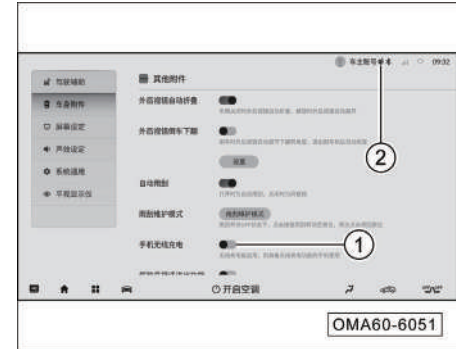

When the ignition is in the “ON” position, select “Settings → Body Accessories → Mobile Phone Wireless Charging” on the AV system display:



- Click the soft key ① to switch on or off the mobile phone wireless charging system.
- The mobile phone wireless charging function is activated by default.

## 4. Operation of systems and equipment

### i NOTE

After the mobile phone wireless charging system is switched on, a symbol ② will be displayed on the status bar of interface. The symbol status will change as the mobile phone wireless charging system is used, and if you click the symbol, the corresponding text message will pop up.

### Symbol status

Symbol	Color	Status	NOTE
	White	Standby	The mobile phone wireless charging function is activated, and please use the Qi-certified mobile phone.
	Green	Charging/ Fully charged	—
	Red	Charging failure	Please refer to "Mobile phone wireless charging failure" table

### Mobile phone wireless charging failure

Causes	Troubleshooting
The internal temperature of the wireless charging module is too high.	The temperature is too high, so please move away the mobile phone and make another attempt later.
There are metallic foreign objects in the wireless charging module area, or the mobile phone is not centered in the wireless charging module area	There are metallic foreign objects or the mobile phone is placed improperly, so please clear the foreign objects or relocate the mobile phone.
The power supply voltage of the wireless charging module is too low or too high.	The voltage is abnormal, so please move away the mobile phone and make another attempt later.
The mobile phone request charging power is too high, or the wireless charging module transmit power is too high.	The power is abnormal, so please move away the mobile phone and make another attempt later.
The mobile phone status is abnormal.	The charging is interrupted, so please move away the mobile phone and make another attempt later.

## 4. Operation of systems and equipment

### NOTE

- GAC will not assume responsibility for any problem caused by abnormal use (such as the use of external wireless charging coil); if the product is disassembled or modified without any authorization, the free warranty service will be invalidated.
- Only charge one mobile phone at a time.
- On bumpy roads, the mobile phone wireless charging function may be intermittently discontinued. If the mobile phone deviates from the charging area and its charging stops, please move the mobile phone back to the charging area.
- The effectiveness of wireless charging function depends on both the infotainment unit and the mobile phone, and if either of them is faulty, it may cause charging failure.
- The charging of the mobile phone may be discontinued when the temperature is too high, and will be continued after the temperature decreases.

### CAUTION

- Do not spill water into the storage box, so as to prevent any damage to the electronic components due to water entering the wireless charging module (WCM).
- Please do not place heavy objects in the charging area to avoid damage to the mobile phone wireless charging system.
- If the product is faulty and cannot be used normally, please stop using it and go to the GAC Motor authorized shop for inspection in time.
- If there is a metal foreign object between the mobile phone and the charging area during the wireless charging, do not remove the metal object immediately by hand for fear of finger scalding, and instead, deactivate the wireless charging system and wait until the metal object cools down.

### WARNING

- **Please do not place anything between the mobile phone and the charging pad during the charging. Non-metallic articles may cause the charging performance degradation. Magnetic cards, chip cards or other similar articles may be damaged. Metal foreign objects such as keys and coins may be heated, causing hidden driving safety hazards.**
- **To place metal foreign objects in the wireless charging zone, please first deactivate the wireless charging function through the corresponding menu on the AV system display to prevent the metal objects from sliding into the charging area and being heated during driving, which may cause hidden safety hazards.**
- **When the driver is not in the vehicle, please do not charge the mobile phone in the vehicle, so as to avoid unnecessary safety accidents.**
- **While driving a vehicle, do not check the charging status of your mobile phone for a long time, so as to avoid unexpected traffic accidents.**

## 4. Operation of systems and equipment

### 4.4.7 Trunk

In order to ensure the maneuvering stability of the whole vehicle, the luggage shall be placed as evenly as possible, and the heavy objects shall be placed at the front of the trunk.

#### WARNING

- **The center of gravity of the vehicle carrying heavy objects may change. If heavy objects in the trunk suddenly slip, the maneuvering stability of the vehicle will change.**
- **Articles in the trunk must be fixed, otherwise they may fly forward and cause injuries to the occupants in case of emergency braking or an accident.**
- **Never place fragile, flammable and explosive articles in the trunk!**

#### Trunk space

- The trunk volume can be enlarged by folding down the seat backs of second-row seats and third-row seats. => See [page 95](#)

#### CAUTION

When placing liquids in the trunk, make sure that the container is sealed and the liquid does not leak. Avoid placing liquids on the seat back folded down to prevent liquid leakage and thus wetting the seat.

#### Rear trunk storage box

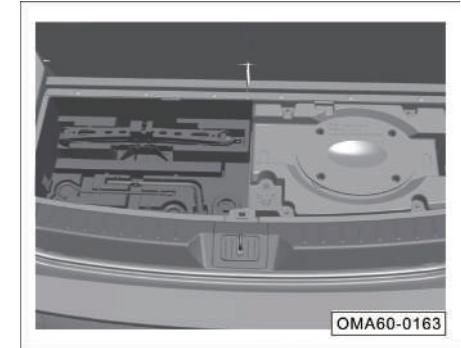

- When you lift the trunk rear carpet, you will find a warning triangle and other driver's tools in the rear storage box.



## 4. Operation of systems and equipment

### 4.4.8 Luggage rack

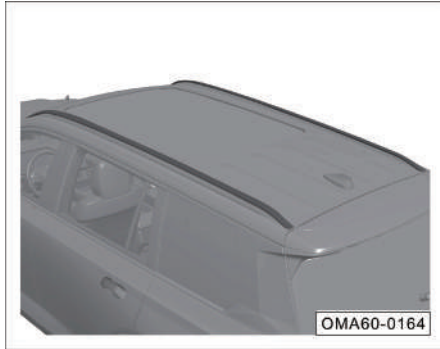

This vehicle is equipped with a luggage rack with a maximum loading capacity of 50kg.

#### WARNING

**Do not carry objects more than 50kg on the luggage rack!**

### 4.4.9 Accessories and modification

Data labels and signs indicating important data and information about the use of the vehicle are affixed to the fuel tank cap, engine hood latch and other components of the delivered vehicle. Do not remove or damage these labels and signs, and always keep the data and information on them legible.

The vehicle is designed with the latest safety technologies by GAC to ensure excellent active safety and passive safety. Therefore, in order to maintain the excellent characteristics of this vehicle, please be sure to consult the GAC Motor authorized shop before installing accessories or replacing parts.

It is recommended to use accessories and parts approved by GAC. Other parts than those GAC genuine parts will not be covered by the warranty.

#### WARNING

**The installation of inappropriate accessories or the modification of the vehicle may affect the maneuvering stability and other performance of the vehicle, and even may cause serious casualties.**

To install a car phone, alarm device, transceiver, low-power AV system, etc., ensure that they will not interfere with the electronic control unit such as anti-lock braking system (ABS) on the vehicle.

## 4. Operation of systems and equipment

Before installing the accessories, please ensure that:

1. The accessories neither dim the lamps, nor affect the normal operation or performance of the vehicle.
2. For the vehicle equipped with side curtain airbags, do not install any accessories on the B-pillar or across the rear door window, as they may cause interference to the normal deployment of the side curtain airbags.

### NOTE

When additions (such as headrest, seat cover, floor mat, sun protection mat, etc.) are required, inferior additions may contain VOCs that do not meet national standards, and may emit unusual odors, causing hidden dangers that affect the air quality in the vehicle; therefore, the genuine high-quality additions are recommended to ensure a comfortable driving environment.

### Modification of vehicle

Dismantling the parts from the vehicle or replacing the genuine parts with non-GAC Motor parts will seriously damage the maneuvering stability and reliability of the vehicle. For example:

- The installation of larger or smaller wheel and tire will interfere with the normal operation of the anti-lock braking system (ABS) and other systems.
- The modification of the steering wheel and other safety devices may cause the system failure.

### WARNING

- **Improper modification of the vehicle or installation of inappropriate accessories may easily cause failures and accidents. The accessories and parts approved by GAC are always recommended, because the adaptability, reliability and safety of these accessories and parts have been strictly verified by GAC.**

### WARNING

- **Improper modification or maintenance of the vehicle may weaken the protective effect of the airbag, resulting in the system failures and fatal accidents. The accessories such as beverage cup holder and mobile phone holder shall not be installed or connected to the cover of the airbag assembly or within the working range of airbags.**
- **Improper operation or modification of the vehicle (such as the modification of the engine, brake system, or components that affect the performance of the wheels and tires) will affect the SRS function, causing serious casualties.**
- **Do not install wheels and tires that are not approved by GAC.**
- **The modifications of the front and the engine compartment of the vehicle may weaken the function of the pedestrian detection system and violate road traffic regulations.**

### 4.5 A/C system

#### 4.5.1 General description

The A/C filter can filter pollen and dust entering the air inlet of A/C system.

The A/C filter must be regularly cleaned and replaced according to "Regular Maintenance Schedule" in Warranty Manual.

If the vehicle often runs in areas with poor air quality, the replacement interval of the A/C filter should be shortened. If the airflow from the A/C air outlet is not as smooth as usual, it may be due to the dirty and clogged A/C filter. In this case, clean or replace the A/C filter as soon as possible.

#### WARNING

**If the air in the vehicle is foul, it will make the driver easily fatigued, lack of energy, and distracted, which is easy to cause an accident, resulting in personal injury or even death. Therefore, enable the air circulation mode according to the actual situation.**

#### CAUTION

If the A/C system has failures (such as no cooling, odor in outlet air, etc.), please go to the GAC Motor authorized shop for inspection.

#### NOTE

- When the ignition switch is in "ON" position, the A/C system can be operated.
- When the A/C is turned on, there will be water dripped under the vehicle. Prolonged parking with the A/C on will cause accumulated water, which is normal.
- Regularly clean the front windshield wiper cover and remove snow, ice, and leaves to avoid clogging the A/C air intake and ensure normal air intake.
- The A/C system can achieve its maximum effect with the windows and sunroof \* closed. However, when the inside temperature is high under hot sun, open the windows briefly to dissipate the inside heat, and then enable the A/C for cooling.

## 4. Operation of systems and equipment

### 4.5.2 A/C system

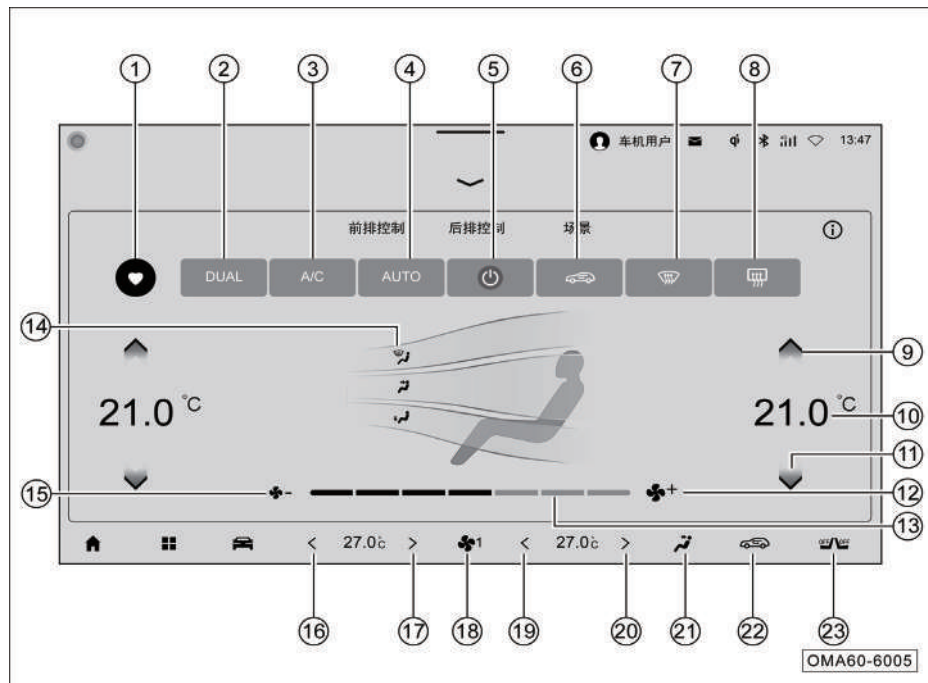







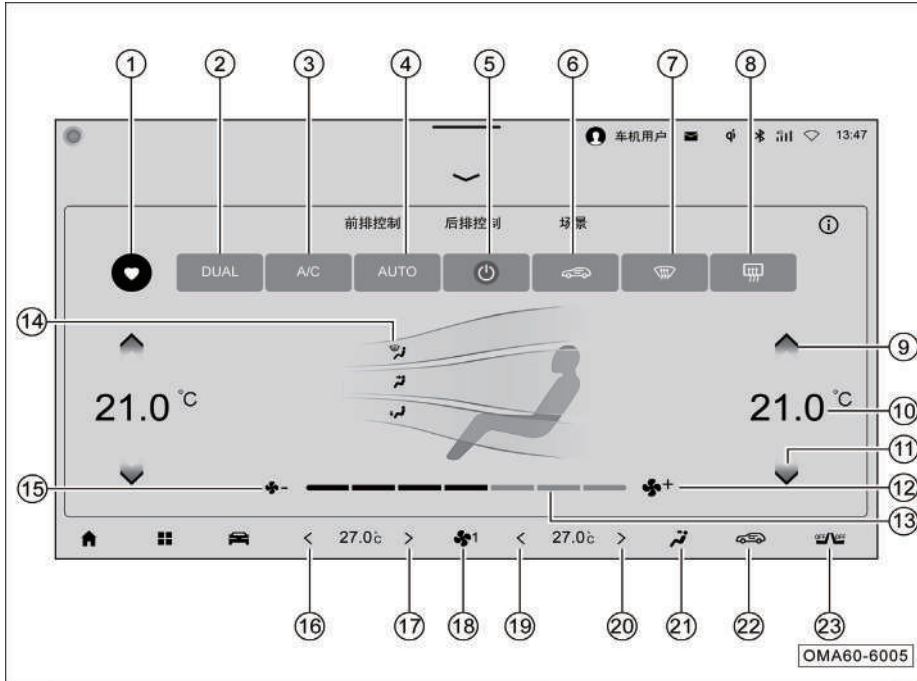





#### Description of HCP

- ① ♥ Favorites button
- ② “Sync” button
- ③ Cooling button
- ④ AUTO mode button
- ⑤ ⏻ ON/PFF button
- ⑥ 🔄 Recirculation/fresh air mode button
- 🔄 Recirculation mode button
- 🌬 Fresh air mode button
- ⑦ 🌬 Front windshield defrosting/defogging button
- ⑧ 🌬 Rear windshield defrost/defog button
- ⑨ ▲ Temperature Up button
- ⑩ Temperature display (single zone left and right synchronization)
- ⑪ ▼ Temperature Down button
- ⑫ 🌬 Fan speed increase button

## 4. Operation of systems and equipment



### Description of front A/C control interface (continued)

- ⑬ Air volume level display
  - Display the air volume (7 levels), swipe the button left and right to adjust the air volume.
- ⑭  Air supply mode button
- ⑮  Fan speed decrease/A/C off button
- ⑯  Driver side temperature Down button
- ⑰  Driver side temperature Up button
- ⑱  Fan speed control button
- ⑲  Front passenger side temperature Down button
- ⑳  Front passenger side temperature Up button
- ㉑  Air supply mode button
- ㉒  Recirculation/fresh air mode button
  -  Recirculation mode button
  -  Fresh air mode button
- ㉓  Seat ventilation button

## 4. Operation of systems and equipment

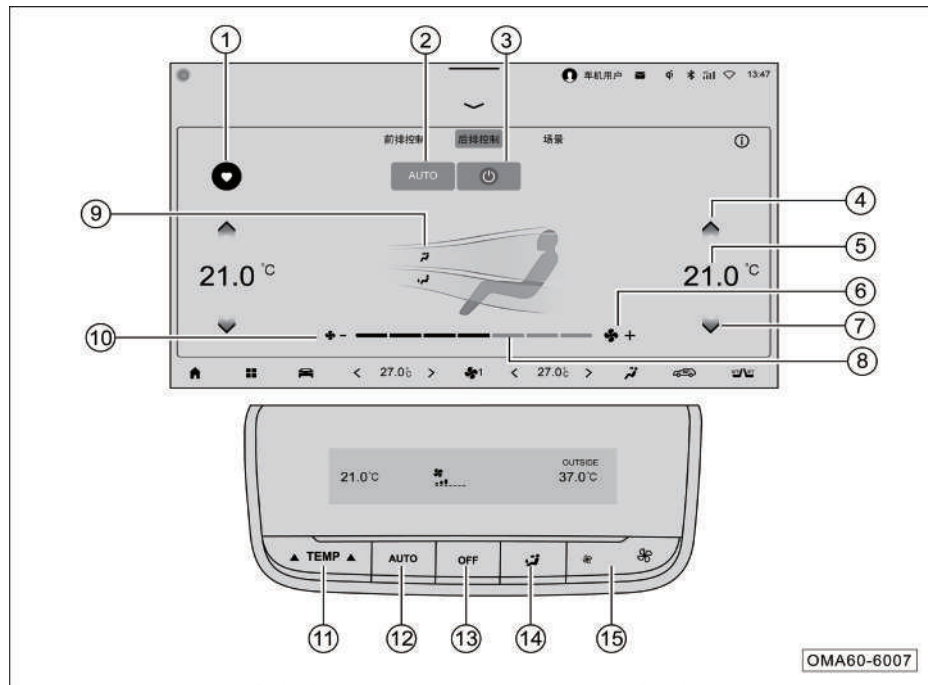

### Description of rear A/C control

- ① ♥ Favorites button
- ② AUTO mode button
- ③ ⏻ ON/OFF button
- ④ ▲ Temperature Up button
- ⑤ Temperature display (single zone left and right synchronization)
- ⑥ 🌀+ Fan speed increase button
- ⑦ ▼ Temperature Down button
- ⑧ Air volume level display
- Display the air volume (7 levels), swipe the button left and right to adjust the air volume.
- ⑨ 🌀 Air supply mode button

## 4. Operation of systems and equipment

- ⑩ Fan speed down button
- ⑪ Temperature control button
- ⑫ AUTOMode button
- ⑬ OFFbutton
- ⑭ Air supply mode button
- ⑮ Fan speed adjustment button

### Temperature display

The temperature setting button on the front A/C interface of the AV system is used to set the target temperature of the left and right front areas, and the temperature values are respectively displayed on the display of the AV system.

The temperature setting button on the rear HCP and the temperature setting button on the rear A/C interface of the AV system can be used to set the rear temperature, which is displayed on the LCD of the rear HCP and the AV system display.

- Press "TEMP" on the AV system display to adjust the temperature by swiping up and down in increments of 0.5°C.

### Temperature control button

- The indoor temperature can be set by operating the and buttons. The temperature starts to scroll when the button is pressed and held or (more than 0.5s), and stops scrolling when the button is released.
- The set temperature is adjustable within 18.5~31.5°C at increments/decrements of 0.5°C. When the set temperature is lower than 18.5°C, the temperature is displayed as LO, when the set temperature is higher than 31.5°C, the temperature is displayed as HI.

In AUTO mode, when LO/HI is displayed, the system will keep high air volume.

In AUTO mode, in order to obtain the most satisfactory indoor temperature, it is recommended to set the temperature to 25.0°C, and adjust the temperature if necessary.

### CAUTION

The temperature value displayed on the AV system display is the target value of temperature setting, not the actual measured value of the indoor temperature.

### A/C button

The A/C system will start cooling if the A/C button is pressed.

The A/C system will stop cooling if the A/C button is pressed again.

### Air volume setting

Press or to increase/decrease the air speed by one level. The AV system display shows the corresponding fan speed level.

In AUTO mode, the A/C system will automatically control the fan speed, and operating the or button will change the system state from AUTO mode to manual mode.







### Turning off of A/C

Click the soft key on the AV system display or the rear A/C OFF button to turn off the A/C system.

After the A/C system is turned off:

- Operating the button, button or will not turn on the A/C system.

## 4. Operation of systems and equipment



- Operating the  temperature Up button,  temperature Down button, or “Sync” button will be invalid.
- Operating the  OFF button, A/C button,  button,  button,  button, AUTO button will turn on the A/C system.

### Air circulation (AUTO)\*

The A/C system will work, the button indicator lamp  will come on, and the recirculation/fresh air damper will work in the recirculation/fresh air mode if the “AUTO” physical button of the A/C or the “AUTO” soft key on the front A/C control panel of the ACU is clicked. This mode automatically controls the air intake mode according to the quality of outside air and ambient temperature. When the quality of outside air is poor, the recirculation mode will be set; when the quality of outside air is good, the fresh air mode will be set.

### Air circulation (manual control)\*

Repeatedly click the  soft key to switch the air circulation between the auto recirculation/fresh air mode, recirculation mode and fresh air mode.

-  Recirculation: The air circulation is set to recirculation mode.
-  Fresh air: The air circulation is set to fresh air mode.



### CAUTION

- Long-term recirculation mode will cause accumulation of carbon dioxide in the vehicle, which is not conducive to keeping driver clearheaded.
- The recirculation mode in cold or rainy days can easily cause the windows to mist up, affecting the driver's visibility and probably causing serious accidents.



### AUTO mode

The button indicator lamp will come on and the front and rear A/C systems will enter the auto running mode if the “AUTO” soft key on the AV system front/rear A/C display interface and the “AUTO” button on the rear A/C panel are pressed. The following functions will be automatically controlled according to the set temperature:

- Outlet air temperature.
- Air volume at the air outlet.
- Air supply mode.
- Air circulation mode.
- Working state of the A/C cooling function.

Press the  and  soft keys or  soft key to exit the auto mode of the A/C system.

### Front windshield defrost/defog function

The button indicator lamp will come on and the front windshield defrost/defog function will be activated if the  button on the A/C panel or the  soft key on the AV system A/C interface is pressed.

The button indicator lamp will go out, front windshield defrost/defog function will be turned off and the state before defrosting/defogging will be restored if the  button is pressed again; or press the AUTO button to enter the AUTO mode or turn off the front windshield defrost/defog function.



### CAUTION

- When the temperature is set to the lowest, the defrost/defog function will cause the outer surface of the windshield to mist up, affecting the driver's visibility and probably causing serious accidents. To use the defrost function, it is recommended to set the temperature to a hot or warm position.
- When using the defrost/defog function, if you manually turn off the A/C cooling function, it will cause the front windshield to mist up, affecting the driver's visibility and probably causing serious accidents.
- To use the defrost and defog functions, for quick defrosting and defogging, the default air volume level is higher than 5, and the noise of the air outlet is relatively large. If you want to reduce the noise, you can manually reduce the air volume on the premise of ensuring the driver's sight.

### Rear windshield defrost/defog function

If the  button is pressed, the rear windshield defrost/defog function will be activated, and the rear windshield will be electrically heated.

If the  button is pressed again, the rear windshield defrost/defog function will be deactivated. If you do not manually turn off the rear windshield defrost/defog function, this function will be automatically deactivated after 15 minutes.



### NOTE

- With the engine shut down, using the rear windshield defrost function for a long time will cause low battery voltage, making it impossible to start the engine.
- The rear defrost function is limited to ensure starting performance under low battery.



### Air supply mode

Front air supply mode



Click the air supply mode button on the front A/C control interface of the AV display or in the resident toolbar at the bottom of the AV display to adjust the front air supply mode.

Switch the AV system to the A/C system control interface, click the  soft key to switch the air supply mode manually; in the AUTO mode, the A/C system will automatically control the air supply mode, and when the  soft key is pressed, the system will exit the AUTO mode.

When manually selecting through the front A/C control interface, click the  soft key to switch cyclically according to the following air supply modes:

-  Panel mode: Air flows out from the panel outlets.
-  Panel/floor mode: Air flows out from the panel and floor outlets.
-  Floor mode: Air flows out from the floor outlets.

## 4. Operation of systems and equipment

-  Floor/defrost mode: Air flows out from the front windshield defrost outlets and floor outlets.
-  Defrost mode: Air flows out from the front windshield defrost outlets.

### Rear air supply mode

Press the air supply mode button on the rear A/C panel or the rear air supply mode adjustment button of the AV unit to control the rear air supply mode. The air supply mode is displayed on the rear A/C panel.

Press the mode button  of rear air supply mode adjustment buttons on the front AV to cycle among the  panel mode,  floor/panel mode, and  floor mode.

In auto mode, the air supply mode, as part of the automatic control logic, is automatically selected by the A/C system. The basic factor that affects the air supply mode is the outlet air temperature: when the outlet air temperature is high, most of the air will be directed through the floor outlets; when the outlet air temperature is low, most of the air will be directed through the panel outlets.

### i NOTE

- The panel/floor  mode is mainly used when the outside temperature is slightly lower in spring and autumn. Therefore, the temperature of the upper outlets is slightly lower than that of the lower outlets, which is a normal phenomenon.
- The air supply mode, set temperature and comfort curve can be adjusted for personal comfort.
- In order to ensure that the A/C system can effectively control all the air supply modes automatically, please keep all air outlets open.
- During cold start in winter, in the auto mode, the A/C system will start from the defrost mode and enable a gradual transition to other modes.

### Sync mode

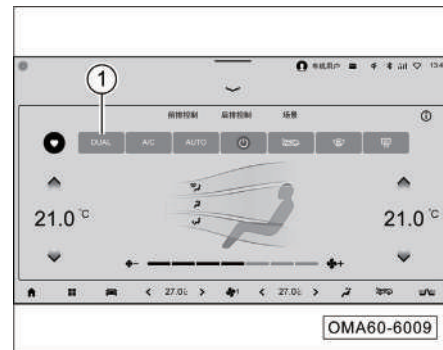

Switch the AV system to the A/C system control interface, click the “Sync” soft key . The soft key indicator lamp comes on, the sync mode is enabled, the A/C system exits the three zone control mode and enters the single zone control mode, and the temperatures in all zones will be controlled simultaneously.

Click the “Sync” soft key . The soft key indicator lamp turns gray, the sync mode is disabled, the A/C system enters the three zone control mode, and temperatures in the left and right zones and rear zone are controlled independently.

### A/C scene\*

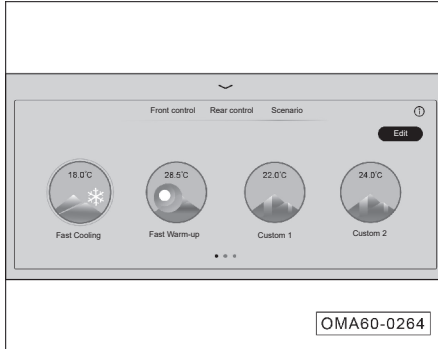

Switch the AV system to the A/C system control interface, and click "Scene" soft key to enter the A/C scene interface.

1. Preset scene 1
  - Fast Cooling: 18°C, AUTO: On, the A/C curve is "Fast", and the temperature is rapidly decreased until the target temperature is reached.
2. Preset scene 2

- Fast Warm-up: 28°C, AUTO: On, the A/C curve is "Fast", the temperature is rapidly increased, and the maximum power is maintained until the target temperature is reached.
3. Add custom items
    - Add the current A/C status as a custom scene as needed.

### A/C control buttons

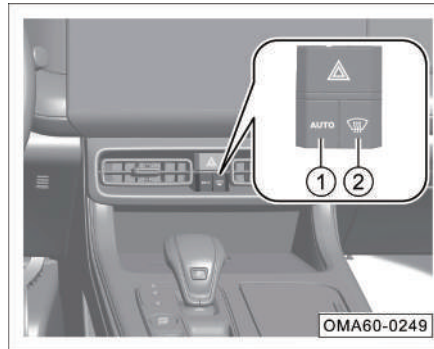

- ① AUTO button
- ② Front windshield defrost/defog button

### 4.5.3 A/C air outlet

#### Panel side air outlet

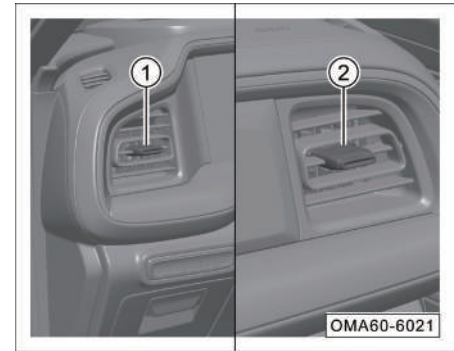

- Toggle the paddle ①/② to adjust the air direction.
- Toggle the paddle ① left / toggle the paddle ② right to the limit position to close the air outlet.

## 4. Operation of systems and equipment

Panel center air outlet

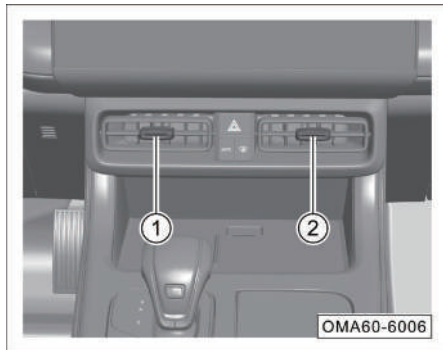

- Toggle the paddle ①/② to adjust the air direction.
- Toggle the paddle ① right / toggle the paddle ② left to the limit position to close the air outlet.

Panel compensation air outlet

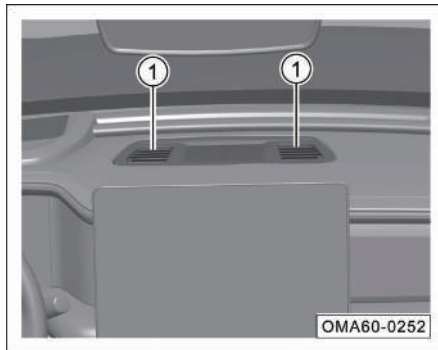

- The compensation air outlet ① is automatically opened in the panel mode, and closed in other modes.

2nd/3rd row air outlet

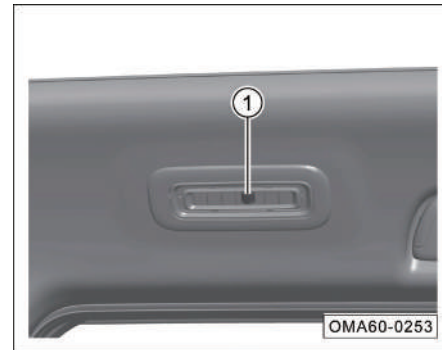

- Toggle the paddle ① to adjust the air direction, or close the air outlet.

### Armrest box air outlet \*

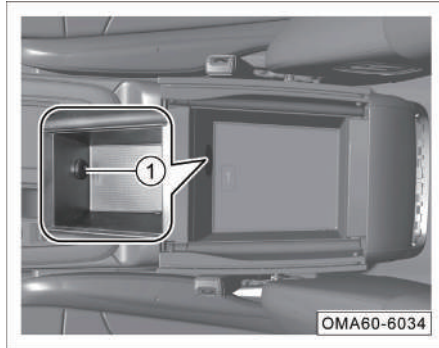

- Turn the knob ① to adjust the air volume or close the air outlet.

## 4. Operation of systems and equipment

### 4.6 AV system

#### 4.6.1 Buttons on the right of the steering wheel

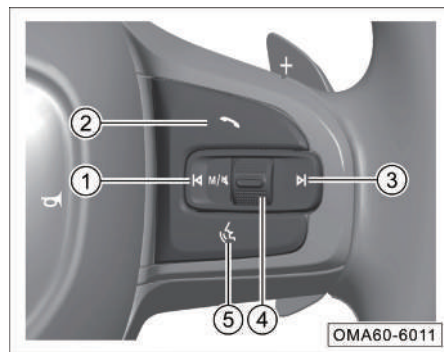

##### ① ◀ button

- In radio mode, press this button to automatically search for a valid station with lower frequency. If a valid station is found, the automatic search will be stopped and the station will start playing.
- In media source playing mode, press this button to skip to the previous track.

##### ② Answer/Hang up

Press:

- When there is no Bluetooth connection, press the button to enter the Bluetooth Connection interface.
- When there is Bluetooth connection, press the button to enter the Bluetooth Call interface.
- When there is Bluetooth connection, if there is an incoming call, press the button to answer the call.
- During a call, press the button to hang up the call.

Press and hold:

- Long press on this button has no effect.
- ③ ▶ button
  - In radio mode, press this button to automatically search for a valid station with higher frequency. If a valid station is found, the automatic search will be stopped and the station will start playing.
  - In media source playing mode, press this button to skip to the next track.
- ④ Audio source switching button/Volume adjustment button/Mute button
  - Press this button continuously to switch between the interfaces as follows: FM → AM → Online Radio \* → USB1 → USB2 → Bluetooth Music → Online Music \* → FM.

- Press and hold this button to mute the media source, and then press this button to unmute the media source.
- Toggle up/down this button to adjust the sound volume.

##### ⑤ Voice control

Press:

- Press the button to enter Yealink APP.

## 4. Operation of systems and equipment

### 4.6.2 Basic operation

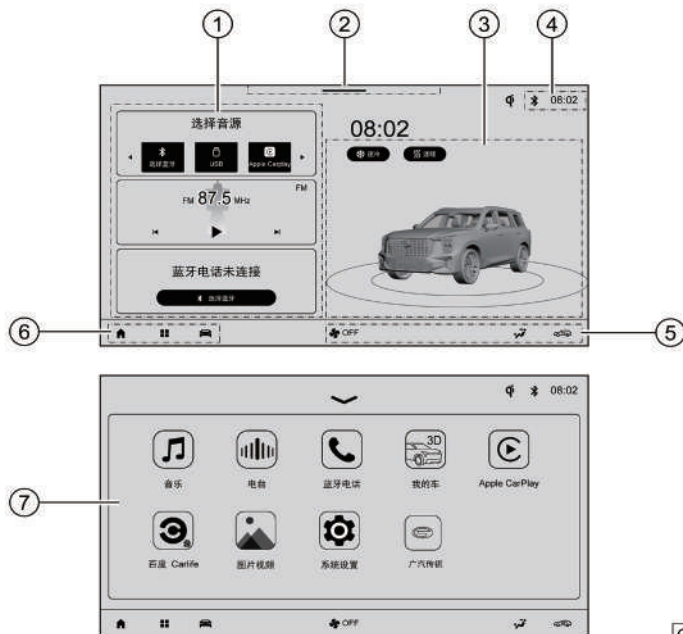

OMA60-0257

Description of function areas in AV main interface:

- ① Smart card area
  - Click the cards to quickly enter the corresponding function interfaces.
  - Cards can be added and sorted in a user-defined way.
- ② Drop-down menu bar area
  - Swipe down to enter the drop-down menu bar control interface.
- ③ Smart scene area
  - The smart scene area includes 3D vehicle model and A/C scene (fast cooling and fast heating).
- ④ System status bar
  - This area indicates “Time”, “Bluetooth Connection”, etc. Click an icon to enter the corresponding function interface.
- ⑤ A/C information display/control bar area
  - This area indicates the A/C state. Click here to enter the A/C control interface.
- ⑥ System navigation bar area
- ⑦ Application menu interface

## 4. Operation of systems and equipment

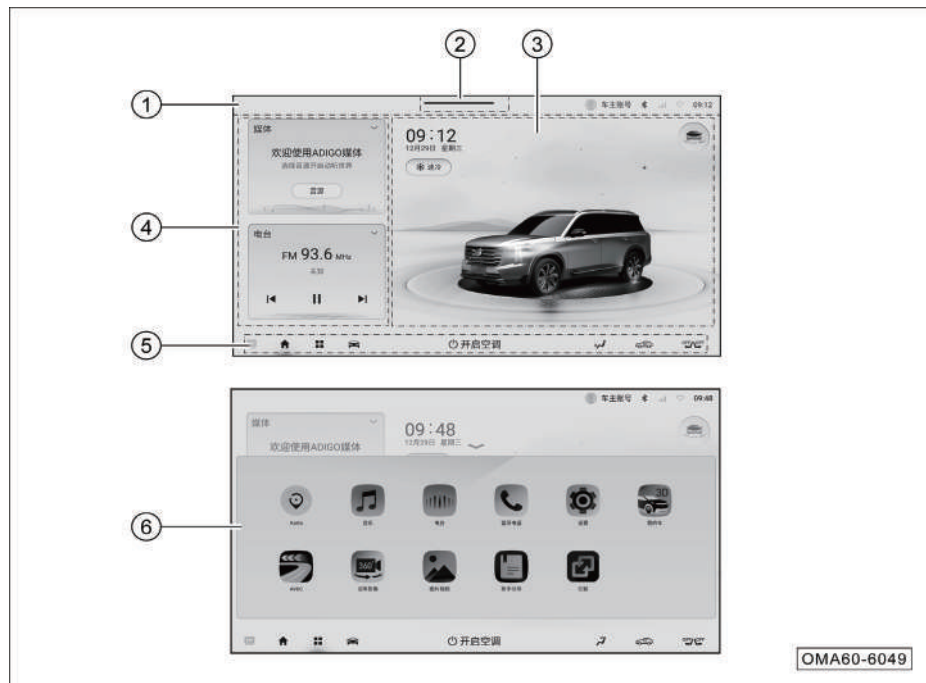





Description of function areas in AVN main interface:

- ① System status bar
  - This area indicates “account shortcut entry, message center, DVR display and entry, wireless charging, connection display and shortcut entry, time display and format quick adjustment entry”, etc. Click an icon to enter the corresponding function interface.
- ② Drop-down menu bar area
  - Swipe down to enter the drop-down menu bar control interface.
- ③ Smart scene area
  - The display can be switched between two different scenes, that is, scene body and scene cruise map.
- ④ Smart card area
  - Click the cards to quickly enter the corresponding function interfaces.
  - Cards can be added and sorted in a user-defined way.



## 4. Operation of systems and equipment

- ⑤ Bottom toolbar
- Home button  : Click it to return to the main interface.
  - System menu button  : Click it to enter the application menu interface.
  - Driving control panel button  : Click to enter the driving control panel.
  - Seat module button  : Click the button to enter the seat ventilation interface.
  - A/C information display/control bar area: Display the current A/C information, click the left/right A/C area to enter the A/C setting interface.
- ⑥ Application menu interface
- Click the menu button  in the toolbar at the bottom of the desktop to enter the application menu interface.

### Time setting

#### Vehicles with AV unit

- Set the time through “System Settings→System Settings→Basic Settings→Time and Date”.

#### Vehicles with AVN unit

- The AVN unit will automatically and synchronously refresh the GPS time, without manual setting.

### Drop-down menu bar

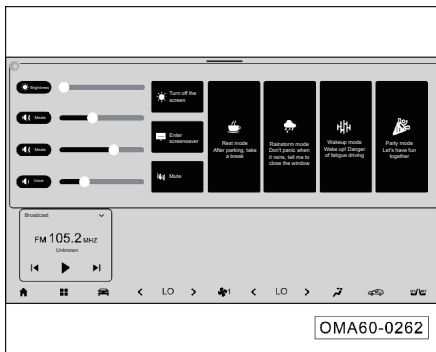

In any other interface, swipe down from the top of the screen (drop-down menu bar) to show the drop-down menu. Click it  or swipe it up to hide the drop-down menu bar. In the drop-down menu bar interface, if there is no operation, the drop-down menu will be automatically hid after 20s.

Click any function button in the drop-down menu bar to turn on/off the corresponding function, or enter the corresponding function interface.

### i NOTE

The AVN unit is taken as an example in the illustration. The operation of the AV unit is similar. Please refer to the actual vehicle configuration for specific functions and interfaces.

### My Car

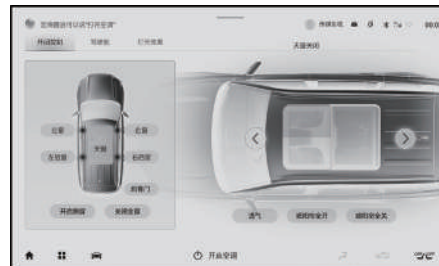

After the AV system works normally, click on the 3D car model in the smart scene area in the main interface or the “My Car” soft key in the application menu interface to enter the My Car interface.

“Opening/closing control (sunroof\*, windows, liftgate)”, “Cabin (seat adjustment, rearview mirror adjustment)”, “Lighting effect (light show, ambient lamp)” can be adjusted.

## 4. Operation of systems and equipment

### i NOTE

The AVN unit is taken as an example in the illustration. The operation of the AV unit is similar. Please refer to the actual vehicle configuration for specific functions and interfaces.

### CarPlay\*



The CarPlay allows you to use navigation, make calls, send and receive messages, and enjoy music while focusing on driving.

- Use a USB cable to connect the phone and the USB port of the main unit. After successful connection, the system will automatically switch to the CarPlay main interface, and the CarPlay icon in the system interface will be highlighted.
- In other function interfaces, you can access the Apple CarPlay system by clicking on the Carplay icon in the main interface card or the Apple Carplay icon in the application menu interface.

### i NOTE

- For the functions and applications supported by CarPlay, refer to the Apple's official website. According to the information released by Apple in 2019, Apple CarPlay supports iPhone5 and above.
- When using CarPlay, make sure that the CarPlay function is enabled via "Settings → General → Access Restriction" on the iPhone, otherwise the iPhone will only be used as an iPod and the Apple CarPlay will not be available.
- Please use the genuine iPhone data cable, otherwise connection failure may occur.

### Voice\*

After the AV system is turned on and works normally, wake up the voice recognition engine in the following ways before issuing a voice command to the voice recognition engine that needs to be waken up:

- Press the button  on the right side of the steering wheel to enter the voice mode.
- Wake-up word: The default wake-up-word is "Hello, GAC", and another wake-up word can be customized.

Customize wake-up word as follows:

1. Wake up the voice assistant by saying "Hello, GAC", and say "Give you a name XXX" to set another wake-up word.
2. The user can set the voice function through "Settings → Voice Settings → Voice Assistant".

After you wake up the voice recognition engine and hear a beep, you can perform the voice control setting.

### i NOTE

Whether the voice recognition can work is affected by external factors such as the objective environment (including ambient noise, network signal, etc.), user habits and pronunciation. The specific recognition effect depends on the usage scenarios of the actual vehicle.

### Voice settings\*



Enter the "Settings→Voice Settings→Voice Assistant" interface of the AV system to set the voice function, and select on/off.

## 4. Operation of systems and equipment

### 4.6.3 Radio

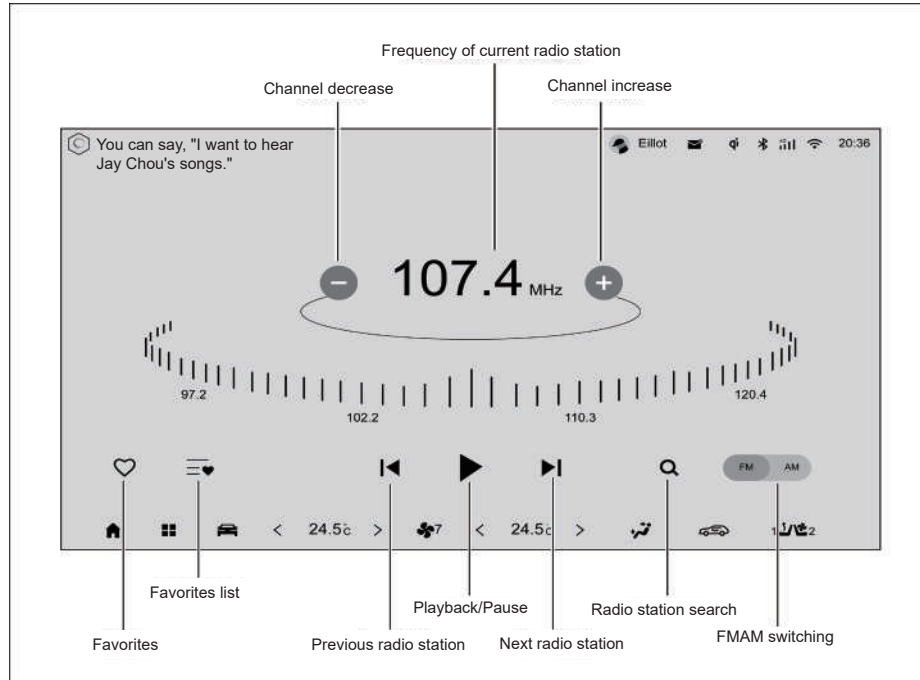

Enter the Radio interface in the following ways:

- Click the "Radio" card in the main interface to enter the radio mode.
- Press the button on the right side of the steering wheel repeatedly to switch to the radio mode.
- Enter the radio interface by clicking the "Radio" soft key in the application menu interface.

#### **i** NOTE

The radio station is divided into two modes: local radio and online radio. Only local radio is described here.

## 4. Operation of systems and equipment

### 4.6.4 Local music

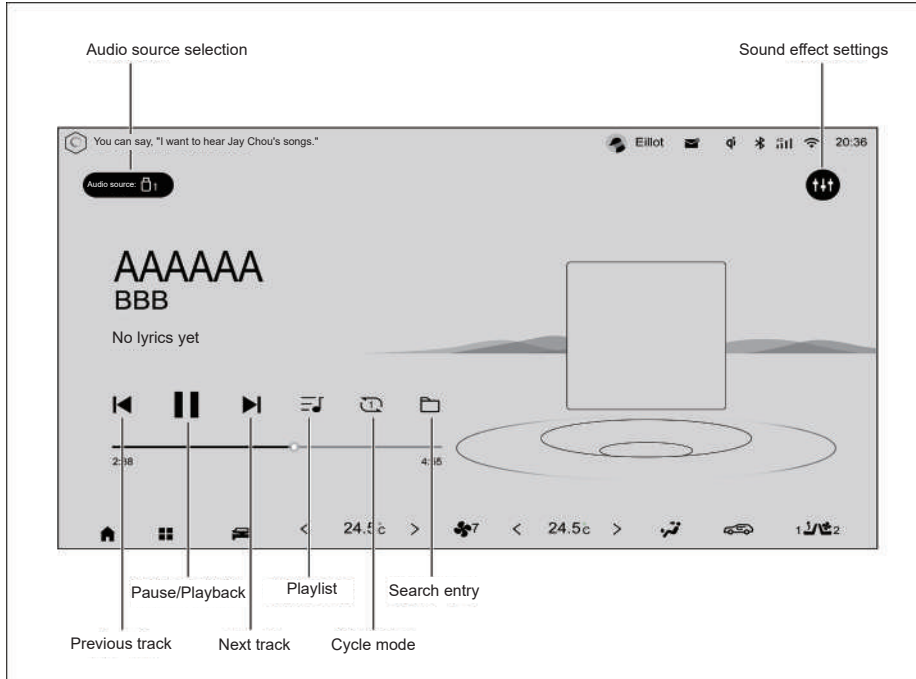

Enter the local music playback interface in the following ways:

- Click the “Music” card in the main interface to enter the local music interface.
- Press the button on the right side of the steering wheel repeatedly to switch to the local music interface.
- Click the “Music” soft key in the application menu interface to enter the local music interface.

#### **i** NOTE

- In case of online music, click “Music” card in the main interface to enter the online music playback interface, and not to enter the local music interface.
- The AVN unit music application has two functions: “online music and local music”, and only local music function will be described herein.
- The AV system only supports the use of USB devices in FAT16/32 format.

## 4. Operation of systems and equipment

### 4.6.5 Bluetooth function

#### Bluetooth mode of AV unit

Enter the Bluetooth mode in the following ways:

- Click the “Bluetooth phone” soft key in the application menu interface to enter the Bluetooth mode.
- Click the “Bluetooth phone” card in the main interface in the card mode to enter the Bluetooth mode.
- Click the soft key in the drop-down menu  to enter the Bluetooth mode.

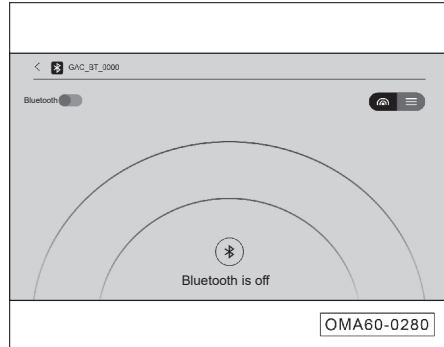

- If there is no Bluetooth device connected, enter the Bluetooth connection interface in the above way.

- After turning on the Bluetooth function by clicking the “Bluetooth ON/OFF” soft key , the IHU will automatically search for nearby Bluetooth devices. The Bluetooth connection interface displays two display modes: “Radar” and “List”.

#### Radar display mode



- Bluetooth device: The names of nearby Bluetooth devices that can be connected will be displayed, and select the device to be connected and click to connect it.
- Switch to list display mode: Click the  soft key to switch to the list mode, the number displayed in the list mode is the number of Bluetooth devices that can be connected around.

#### List display mode

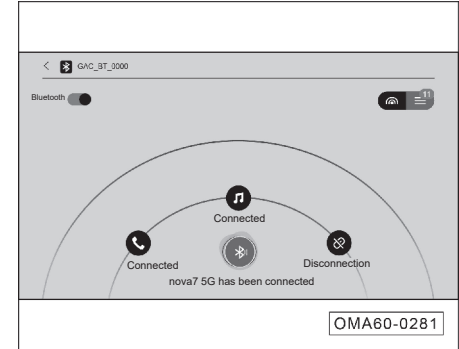
- Bluetooth device: Bluetooth devices that can be connected around will be displayed in a list.
- Switch to radar display mode: Click the  soft key to switch to the radar display mode, the number of Bluetooth devices that can be connected around will be displayed.



After the Bluetooth connection, the status bar icon will be highlighted, and the connected Bluetooth device name will be displayed on the Bluetooth connection interface:

- Click the  soft key to synchronize phone numbers, contacts and other information.
- Click the  soft key to synchronize the song name, lyrics and other information of Bluetooth music.
- Click the  soft key again to disconnect the Bluetooth.

## 4. Operation of systems and equipment



### Bluetooth mode of AVN unit

Enter the Bluetooth mode in the following ways:

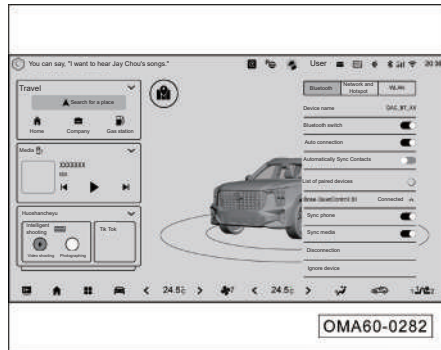
- Click the “Bluetooth phone” soft key in the application menu interface to enter the Bluetooth mode.
- Click the “Bluetooth phone” card in the main interface to enter the Bluetooth mode.
- Click  icon in the status bar in the upper right corner of the AV system interface to turn on Bluetooth.



- If there is no Bluetooth device connected, enter the Bluetooth connection interface in the above way.

- After turning on the Bluetooth function by clicking the “Bluetooth ON/OFF” soft key , the main unit will automatically search for nearby Bluetooth devices.
- After the Bluetooth connection is made, the status bar icon will be highlighted.
- Click the “Auto Sync Contacts” soft key  to synchronize phone numbers, contacts, media and other information.
- Click the Bluetooth  soft key again to disconnect the Bluetooth.

### Bluetooth connection failure

Possible cause	Action
The device's Bluetooth function is set incorrectly	Set the device's Bluetooth so that it can be “Visible to Everyone” or can be searched or opened for detection
The current device is not compatible with the in-car Bluetooth system	Confirm the compatibility of the device with the Bluetooth version, update the operating system of the mobile phone to the latest version and try again
The mobile phone's Bluetooth was connected to other devices	It is recommended to delete the Bluetooth devices that were connected

## 4. Operation of systems and equipment

### 4.6.6 System setting (applicable to cars with AV main unit)

Click the “System Settings” soft key in the menu interface to enter the system settings interface. In the settings interface, click on an option to select it, click on the slider  to enable or disable the function, and drag the progress bar for adjustment.

Settings group	Function	Function	Options
Device connection	Bluetooth	Device name	/
		Bluetooth switch	On/Off
		Auto connection	On/Off
		Automatically Sync Contacts	On/Off
		List of Connectable Devices	/
Sound Settings	System sound effect	Multimedia volume	Range: 0~39
		Call volume	Range: 0~10
		Optimal listening position	Off/Driver/All occupants
		Touch tone	Modern/retro/off
		Startup volume	Adaptive/Invariant
		Warning sound volume	Low/medium/high
		Unlock/lock prompt sound	On/Off
	Interactive sound effect	Touch tone	Modern/retro/off
		Interface sound effect	On/Off



## 4. Operation of systems and equipment

Settings group	Function	Function	Options
Driving assistance	Safe driving reminder	Safe speed reminder	Range: 0~200
	Longitudinal vehicle control assist	Forward collision warning*	On/Off
		Forward collision warning distance setting*	Far/medium/near
		Speed alarm sound*	On/Off
	Lateral vehicle control assist	Active brake assist*	On/Off
		Steering mode	Comfort/Standard/Sport
Towing mode		On/Off	
Body Accessories	Exterior Light	Follow me home	Off/Low beam only/Low beam and rear fog lamp
		Daytime running lamp	On/Off
	Lock/Unlock	Remote unlock	All doors/Driver's door only
		Auto unlock	On/Off
Screen Display	Console display	Console screen brightness mode	Range: 0~100
		A/C interface hold time	5s/10s/15s/30s
System Settings	Basic settings	Time and date	/
		24-hour system	On/Off
	System information	Hardware version	/
		Software version	/
		Memory size	/
		Cleanup acceleration	Cleanup
		Current language	Chinese/English
		Supported languages	Chinese/English
Factory reset	Reset		

## 4. Operation of systems and equipment

---

### 4.6.7 Settings (applicable to vehicles with AVN unit)

Click the “Settings” soft key in the application menu interface to enter the system settings interface. In the settings interface, click on an option to select it, click on the slider  to enable or disable the function, and drag the progress bar for adjustment.

Settings group	Function	Function	Options
Display setting	Center console	Center console display brightness	Range: 0 ~ 100
		Language setting	/
	Instrument	Instrument volume	Low/medium/high
		Language setting	/
		Odometer	Reset
		Distance unit	km/mi
		Unit of measurement of temperature	°C/°F
		Unit of measurement of pressure	kPa/bar/psi
		Backlight of instrument panel	Range: 0 ~ 8
		Rear seat belt reminder	On/Off

## 4. Operation of systems and equipment

Settings group	Function	Function	Options
Driving assistance	Safe driving reminder	Driver status warning	ON/OFF (available settings: Fatigue/Distracted/Fatigue and distraction reminder)
		Safe speed warning (km/h)	OFF ~200
		Prompt type	Tone/Seat vibration/Tone and seat vibration
		Current driving mode memory	On/Off
	Lateral vehicle control assist	Steering mode	Comfort/Standard/Sport
		LKA*	ON/OFF (available settings: Steering /Warning/Steering and warning)
		Automatic lane change *	On/Off
		Emergency lane keeping *	On/Off
	Longitudinal vehicle control assist	Speed limit sign identification*	On/Off
		Speed alarm sound*	On/Off
		Intelligent speed limit*	On/Off
		Forward collision warning*	On/Off
		Forward collision warning distance setting*	Far/medium/near
	Blind spot driving assistance	AEB *	On/Off
		BSD *	On/Off
		Door opening warning*	On/Off
Intersection assist *		ON/OFF (available settings: Warning/Auxiliary braking and warning)	
Rear crossing traffic alert*		ON/OFF (available settings: Warning/Auxiliary braking and warning)	

## 4. Operation of systems and equipment

---

Settings group	Function	Function	Options
		Rear approach alert*	On/Off
		Rear automatic emergency braking *	On/Off
	Parking assist	Parking assist chime	On/Off
		APA voice prompt *	On/Off
		APA parking space push *	On/Off

## 4. Operation of systems and equipment

Settings group	Function	Function	Options
Body Accessories	Lock	Remote unlock	All doors/Driver's door only
		Auto unlock	On/Off
		Intelligent active lock	On/Off
		Intelligent active unlock	On/Off
		Vehicle speed lock	On/Off
		Easy open of liftgate*	Off/on/prompt sound on
		PLG *	On/Off
	Exterior Light	Intelligent high beam*	On/Off
		Intelligent courtesy lamp*	On/Off
		Adaptive light *	On/Off
	Other accessories	Auto folding of exterior rearview mirror	On/Off
		Turning down of exterior rearview mirror when reversing*	ON/OFF/Settings
		Automatic wiper	On/Off
		Wiper maintenance mode	On/Off
		Mobile phone wireless charging*	On/Off
		Driver's seat welcome function	On/Off
		Automatic window closing when hirecar	On/Off
	A/C	Automatic air volume setting	Low air volume*/Medium air volume*/High air volume*
		Intelligent control of recirculation/fresh air mode	On/Off
		A/C comfort curve	Soft/Normal/Fast
Air quality sensor		Low sensitivity/Medium sensitivity/High sensitivity	
Automatic defogging		Low sensitivity/Medium sensitivity/High sensitivity/OFF	

## 4. Operation of systems and equipment

Settings group	Function	Function	Options
Sound Settings	System sound effect	Multimedia volume	Range: 0 ~ 39
		Navigation volume	Range: 0 ~ 10
		Call volume	Range: 0 ~ 10
		3D sound effect	Driver/All occupants/OFF
		Treble	Range: -10 ~ 10
		Alto	Range: -10 ~ 10
		Bass	Range: -10 ~ 10
		Sound field	Reset
		Speed-sensitive volume control	On/Off
		Startup volume	Unchanged/Adaptive
		Unlock/lock prompt sound	On/Off
		Driving assist chime and media sound	Unchanged/Mute
	Interactive sound effect	Touch tone	Modern/retro/off
		Interface sound effect	On/Off

## 4. Operation of systems and equipment

Settings group	Function	Function	Options
General setting	Voice settings	Customized wake-up word	Edit
		Continuous conversation	On/Off
		Wake-up-free duration	15s/30s/60s/90s
		Continuous conversation display mode	All conversations/Effective conversations only
		Global wake-up-free	On/Off
	Basic settings	Time and date	/
		GPS time synchronization	On/Off
		24-hour system	On/Off
		Message push	On/Off
	Navigation signal mode	Navigation signal mode	GPS/BeiDou/GPS+BeiDou
	System information	System version	/
		Review of version features	Review
		System update	Update
		Storage space	Cleanup
Factory reset		Reset	
HUD*	Turning HUD on or off	On/Off	
	Brightness control	Range: 1~20	
	Height adjustment	Range: 1~20	
	Tilt adjustment	Range: 1~20	
	Display information settings	Navigation system/cruise assist system/speed limit information	

## 4. Operation of systems and equipment

### 4.7 Emergency rescue

The emergency rescue functions include automatic call after crash and manual emergency call. Automatic call after crash will be automatically enabled by GAC Motor T-BOX under certain circumstances, while manual emergency call needs to be manually enabled by pressing the emergency call button.

Both the automatic call after crash and manual emergency call can call the emergency contact.

- Automatic call after crash: When the vehicle is involved in an accidental collision and the airbag is deployed, GAC Motor T-BOX will activate the automatic call after crash function to automatically call the set emergency contact.
- Manual emergency call: When the automatic call after crash function does not work, manually press the emergency call button to activate the manual emergency call function to call the emergency contact.

Emergency call button



1. ① SOS button: Press and hold this button for 3s to have the GAC Motor T-BOX make an emergency call and call the emergency contact.

#### **i** NOTE

- The emergency contact phone number is that you designated when you purchase the vehicle.
- Please use the emergency call button only when necessary.



### 5.1 Starting and driving

#### 5.1.1 ENGINE START/STOP button

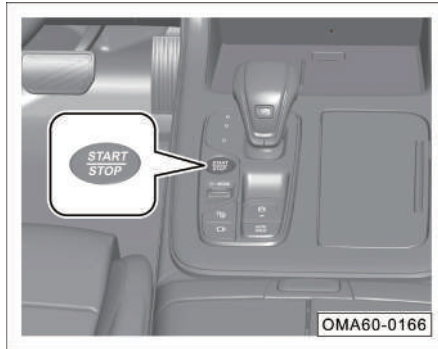

The ENGINE START/ STOP button works only when the intelligent remote control key is detected in the vehicle.

When the transmission gearshift lever is in “P” position and the brake pedal is depressed, the ENGINE START/STOP button backlight will turn green. At this time, press the ENGINE START/STOP button to start the engine.

When the transmission gearshift lever is set to “P” position and the brake pedal is not depressed, press the ENGINE START/STOP button to switch between positions in the following order: “OFF → ACC → ON → OFF”.

- OFF: The ENGINE START/STOP button backlight goes out, and the ENGINE START/STOP button is switched off.
- ACC: The ENGINE START/STOP button backlight turns orange, and the 12V power supply and other accessories can be used.
- ON: The ENGINE START/STOP button backlight turns orange, the instrument cluster backlight comes on, and all electrical consumers can be used.

#### Limphone mode

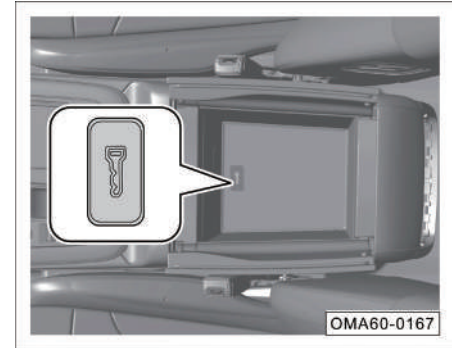

When “No key detected” appears on the instrument cluster display due to low battery of the intelligent remote control key, you can try to place the key horizontally at the mark on the bottom of the front cup holder, then press the ENGINE START/STOP button to switch it to “ACC” or “ON” position and depress the brake pedal, and after the ENGINE START/STOP button backlight turns green, press the ENGINE START/STOP button to start the engine.

This method is intended for emergency start. Please replace the battery of the intelligent remote control key as soon as possible.

## 5. Driving guide

### 5.1.2 Engine start

- Enter the vehicle with the intelligent remote control key.
- Make sure the gearshift lever is in "P" or "N" position.
- Depress the brake pedal and ensure that the ENGINE START/STOP button backlight turns green.
- Press the ENGINE START/STOP button to start the engine.

#### NOTE

In case of a cold start, run the engine at idle speed to warm up it before driving. At the same time, the valve tappet takes a few seconds to reach the normal working pressure and operation noise will occur, which is normal.

#### CAUTION

- The engine start time shall not exceed 15s. If the engine is not started successfully, you must wait about 30s before next attempt.
- Do not depress the accelerator pedal hard to make the engine run at high speed or overload after starting. Otherwise, the engine is likely to be damaged.
- If the battery level is low and the engine cannot be started, try to start it by a jumper cable. => See page 297
- It is prohibited to start the engine by pushing or towing the vehicle.

#### WARNING

- **Do not keep starting the engine for a long time in a poorly ventilated place or an enclosed place. The engine exhaust contains harmful gases which can make people comatose and even suffocate.**
- **Never let the engine idle unattended.**
- **Do not add a starting aid for starting the engine, as it is likely to make the engine run at high speed or cause an explosion.**

### 5.1.3 Engine shutdown

- Park the vehicle steadily and apply the parking brake.
- Set the gearshift lever to the “P” position.
- Release the brake pedal, and press the ENGINE START/STOP button to shut down the engine.

#### **i** NOTE

After the engine is shut down, the radiator fan may still run for a while.

#### Emergency shutdown

When the vehicle is running, press and hold the ENGINE START/STOP button or quickly press it three times to switch it from “ON” to “ACC” position for emergency shutdown of the engine.

The engine can only be restarted in a few seconds after emergency shutdown. Restart the engine as follows:

- After setting the gearshift lever to “P” or “N”, press the ENGINE START/STOP button to start the engine.

#### **⚠** WARNING

**Emergency shutdown is forbidden during normal driving, as it is likely to lead to vehicle damage, safety and power steering failure, and traffic accidents.**

#### Precautions for parking

When parking, set the gearshift lever to “P” or “N” position, and pay attention to the following:

- Pay attention to the direction the vehicle is parked, for fear of damage to the green belt with the exhaust spraying on the plants.
- Try to park on a flat and straight road instead of a steep slope.
- When parking on a slope, regardless of whether the vehicle is facing the top or bottom of the slope, the front wheels should be turned towards the curb.
- Apply the parking brake, shut down the engine, and turn off all lamps and electrical consumers.
- Before leaving the vehicle, be sure to carry valuables and the key with you, and check that the sunroof, windows, doors, and liftgate are closed or locked.

#### **⚠** WARNING

- When leaving the vehicle, be sure to shut down the engine, apply the parking brake and take away the key.
- Do not leave any person in the vehicle. Otherwise, suffocation, coma and even death can easily occur in the closed space.
- Do not park near flammable and explosive materials.

## 5. Driving guide

### 5.1.4 Gear description

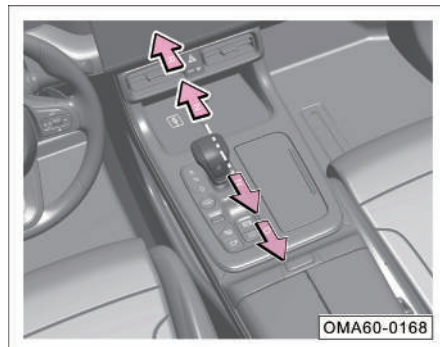

There are “P, R, N, D and S” positions. The engagement/disengagement of P gear and the activation/deactivation of driving mode are controlled by buttons. When the ignition switch is in “ON” position, the corresponding indicator lamp on the shift panel will come on and the instrument cluster will display the corresponding gear after gearshifting.

#### WARNING

**The “R” or “P” gear can be engaged only when the vehicle is completely stationary, otherwise the transmission will be damaged.**

### P: Parking

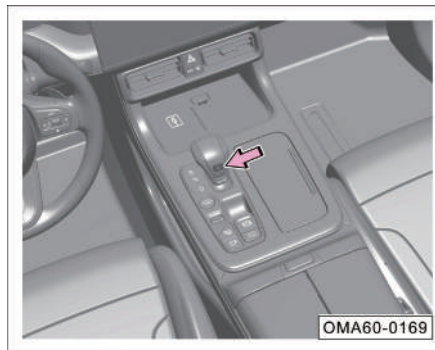

- When the vehicle is completely stationary with transmission in other positions than P, press the “P” button to shift to the “P”.
- Depress the brake pedal and push the gearshift lever forward or backward to shift the gearshift lever out of “P”.

#### NOTE

When the shift system fails and the “P” gear can not be disengaged, please contact the GAC Motor authorized shop for repair.

### R: Reverse

- When the vehicle is stationary, depress the clutch pedal and set the gearshift lever to “R” position until the reversing warning sound is heard.
- Release the brake pedal and slowly depress the accelerator pedal to reverse the vehicle.

### N: Neutral

- When the gearshift lever is in “P” position, depress the clutch pedal and gently push the gearshift lever forward to engage the “N” gear.
- The gearshift lever can be directly set from “R” or “D” position to “N” position.
- Depress the brake pedal when setting the gearshift lever out of “N” position.

#### CAUTION

Do not make the vehicle coast with the gearshift lever in “N” position. Otherwise, it is likely to cause an accident.

### D: Drive

- If the “D” gear is engaged during driving, the transmission system will automatically perform upshift or downshift according to the engine load and vehicle speed.
- Depress the brake pedal, and pull the gearshift lever backward to shift from “P”, “N” or “R” position to “D” position.

### Driving mode

The shift system has the following modes, which can be selected and switched by operating the D-MODE button:

- ECO: In this mode, the slight power hysteresis occurs and fuel consumption is more economical.
- COMFORT: In this mode, the dynamic response and fuel consumption are more balanced.
- DYNAMIC: In this mode, the dynamic response is fast and the fuel consumption is high.
- SNOW \*: This mode is suitable for driving on snowy roads. (4WD)
- SAND \*: This mode is suitable for driving on sandy roads. (4WD)

- MUD \*: This mode is suitable for driving on muddy roads. (4WD)

If you switch the driving mode to SNOW \*, SAND \* or MUD \*, the instrument cluster will display “Driving on paved roads is prohibited in the current mode”.

#### CAUTION

In some cases, the driving mode may automatically jump, for example, in ECO mode, when the vehicle is climbing a steep slope or is under powered, the vehicle may automatically switch to COMFORT mode.

## 5. Driving guide

### Driving mode selection

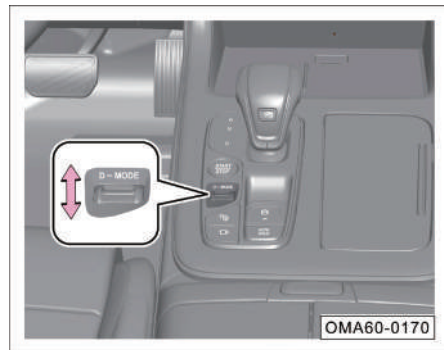

1. Set the ENGINE START/STOP button to "ON" position, and turn the D-MODE knob up/down to switch the driving mode: "ECO → COMFORT → DYNAMIC → SNOW \* → SAND \* → MUD \* → ECO...".



2. On the AV system interface, click the driving control panel key  on the bottom toolbar to view the current driving mode or select the corresponding driving mode.

#### **i** NOTE

Click the back button on the AV system interface or stay for 5s without any operation to hide the mode pop-up window.



If the D-MODE button on the center console is turned, the AV system will pop up the "Driving Mode" interface, and in this case, click "Current Mode Setting" to set the current driving mode parameters.

#### **i** NOTE

If you want to memorize the current driving mode, you need to enable the memory via "Settings → Driving Assistance → Driving Prompt → Current Driving Mode Memory" in the AV system. The current driving mode will be defaulted to the next time you start the vehicle.

### Steering wheel paddles\*



When the vehicle is traveling normally, the driver can complete the upshift or downshift operation by turning the paddles on the steering wheel:

- ① Downshift paddle: Downshift.
- ② Upshift paddle: Upshift.

## 5.2 Braking system

### 5.2.1 Service brake

Under certain driving and weather conditions, squeaks, screams, or other noises may be heard from brakes when the brake pedal is depressed for the first time or lightly stepped on, or braking noise during light or moderate braking, especially for new vehicles (as their brakes have not undergone running-in), which is normal, and does not constitute a failure symptom of braking system nor has effects on the braking safety and performance.

#### CAUTION

- If there is metal friction rasp, the brake lining may be worn to the limit. Please go to the GAC Motor authorized shop for inspection as soon as possible
- If the steering wheel vibrates or twitches continuously during braking, go to the GAC Motor authorized shop for inspection as soon as possible.

#### NOTE

- Do not rest your foot on the brake pedal during driving, otherwise the brakes will heat up to an abnormally high temperature, and the brake linings and brake pads will wear excessively, increasing the braking distance.
- When driving down a long slope or a steep slope, downshift to a low gear (in manual mode) to avoid continuous application of the brake, so as to make full use of engine braking and reduce brake load.
- Continuous application of the brake will cause brake overheat and result in a temporary loss of braking performance.

## 5. Driving guide

---

### NOTE

- Under normal driving conditions, brake linings will wear, and dust will accumulate on wheels, which is inevitable but yet has no effect on the braking performance.
- If rust and corrosion exist because the brake linings and brake discs are not used or used rarely, noise may be heard from brakes for the first use. This is normal. It is recommended to choose a safe area and good road conditions and brake the vehicle several times to clean the brake linings and brake discs.

### Brake booster

The brake booster is used to increase the pressure applied by the driver on the brake pedal, and it only works when the engine is running.

If the brake booster does not work properly due to a fault, or when the vehicle is towed, the force on the brake pedal must be increased to compensate for the assist power loss of the brake booster.

### WARNING

- **Never make the vehicle coast with the engine shut down, because at this moment, the brake booster does not work, the braking distance will be greatly increased, and an accident is likely to be caused.**
- **If the brake booster does not work (for example, when the vehicle is being towed), please depress the brake pedal with force much greater than that applied under normal condition.**

### Braking effect and braking distance

The braking effect and braking distance mainly depend on the driving environment, road conditions and driving style,

With worn brake linings, the vehicle cannot be braked effectively. The wear rate of brake linings mainly depends on the vehicle operation conditions and driving style. If the vehicle often runs for urban driving, short-distance driving, or as a racing vehicle, it is recommended that the driver checks the brake lining thickness more frequently based on the maintenance cycle specified in the Warranty Manual.

After wading, heavy rain or vehicle washing, brake linings may get wet or icy (in winter), resulting in a reduction in braking effects. In this case, the brake pedal must be lightly depressed to heat the brake by friction and evaporate the moisture to restore braking effects.



### WARNING

A new tire and brake lining having not undergone running-in do not have the best adhesion and friction characteristics.

- New tires do not yet have the best adhesion, so please drive carefully for the first 500km to avoid accidents!
- New brake linings in the first 200km to 300km driving distance do not get the best friction characteristics, and braking effects are not as good as expected, so new brake linings must be subject to running-in. Braking effects can be compensated by increasing the force applied to the brake pedal. New brake linings must also be subject to running-in.
- During driving, do not get too close to other vehicles or bring the vehicle to a situation where emergency braking is necessary. Take care especially when driving with a new tire and new brake lining having not undergone running-in, for fear of accidents!

### WARNING

When the brake is wet or icy or when the vehicle is running on a salted road, the braking lag may occur, resulting in a longer braking distance. Therefore, be careful to prevent accidents.

- A longer braking distance or a fault in the braking system will increase the accident rate.
- Lightly depress the brake pedal to check the brake.
- Lightly depress the brake pedal to dry brakes or remove ice or anti-skid salt from brakes.

### WARNING

When brakes are overheated, braking effects will reduce, increasing the braking distance!

- Take care to avoid overheating brakes.
- When driving downhill, brakes are likely to be overheated as the brake load increases.
- It is recommended to engage a low gear (in manual mode) before driving down a long and steep slope to reduce the vehicle speed, and make full use of the engine braking effect to reduce the brake load.
- Do not keep depressing the brake pedal. Otherwise, the brake will overheat and the braking distance increases. Brake the vehicle intermittently according to road and traffic conditions.

## 5. Driving guide

### WARNING

- The brake fluid must be changed every two years. If the brake fluid stays in the brake system for a long period, air resistance may occur in the pipeline during braking, reducing the braking effect significantly and impairing driving safety, and even causing failure of the brake system, resulting in an accident thereby!
- If the front spoiler is out of standard or damaged, it will block the cooling airflow to brakes, causing brakes to overheat and degrading the braking effect.

### 5.2.2 Electric park brake (EPB)

The driver can apply or release the parking brake by operating the EPB button. HSA can be applied for driving on a slope. When the accelerator pedal is depressed with the vehicle parked, the EPB will be automatically released to provide driving assistance for the driver.

### CAUTION

The EPB will apply a fixed force according to the gradient for braking.

- If the vehicle slides downwards after parking, the EPB will automatically increase the brake force.
- If the vehicle continues to slide after the braking force is automatically increased, please depress the brake pedal and drive the vehicle to a flat road. Contact the GAC Motor authorized shop for inspection in time.

### Application of static park brake

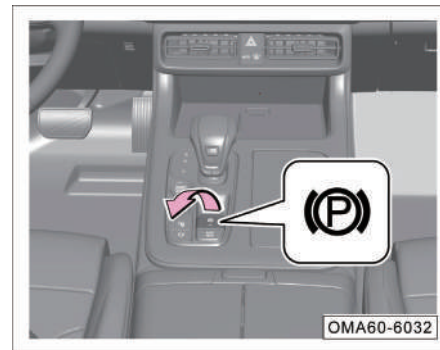

- When the vehicle is stationary, pull up the EPB button as arrowed. The button indicator lamp and the indicator lamp (P) on the instrument cluster will come on, indicating that the EPB has been applied.
- When the gearshift lever is moved to the "P" position from other positions, the EPB will be applied automatically.
- When the vehicle is powered off, the EPB will be applied automatically.

### WARNING

When the vehicle is running, do not apply the EPB for speed reduction unless necessary, as the EPB only applies braking force to rear wheels, which is likely to cause traffic accidents.

### NOTE

- The EPB can also be applied when the vehicle power switch is set to "OFF" position.
- After the vehicle is parked steadily, the EPB should be applied first.
- When the EPB is working, operating noise can be heard, which is normal.
- If the vehicle is coupled with a trailer or is to be parked on a steep slope, it is recommended to pull up the EPB button again after the first application of EPB to ensure the maximum braking effect.

### NOTE

- On a slope with a gradient of 17% to 30%, in 5 minutes after the EPB is applied for the first time, it will be applied again. At this time, operating noise can be heard, which is normal.
- Be sure to apply the EPB during parking.

### Release static park brake

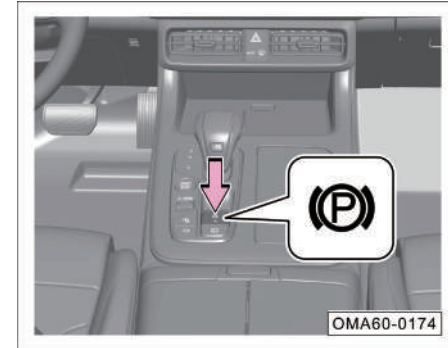

- When the vehicle power switch is set to "ON" position, depress the brake pedal.
- Press the EPB button as arrowed. The button indicator lamp and the indicator lamp (Ⓟ) on the instrument cluster will go out, indicating that the EPB has been released.

## 5. Driving guide

### **i** NOTE

- If the EPB cannot be released statically when the gearshift lever is at “P” position, the instrument cluster will give an alarm to remind you.
- If the EPB button is pressed without depressing the brake pedal, the EPB will not be released, and the instrument cluster will give a visible warning tell-tale together with an audible beep alarm.
- When the EPB is being released, operation noise will occur, which is normal.
- When the battery is low, the system cannot release the EPB. If conditions permit, you can connect a jumper cable for emergency start, and then release the EPB. Contact the GAC Motor authorized shop for inspection.
- If the EPB has not been used for a long time, the system will perform automatic test, and operation noise will be heard at this time.

### Application of dynamic emergency brake

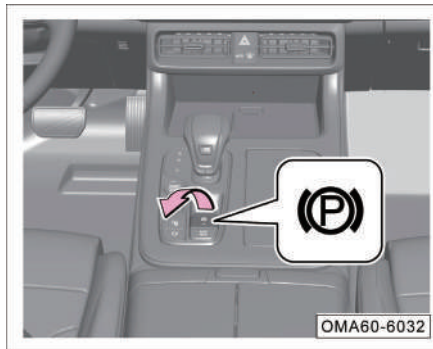

- During driving, dynamic emergency braking can be achieved by pulling up the EPB button continuously as arrowed. If the accelerator pedal is depressed during the emergency braking process, the system will release the brake. If a non-driver operation causes emergency braking, please depress the accelerator pedal to the floor repeatedly to release the brake.

### **👁** CAUTION

In the following cases, operate the EPB button again. If the fault is not eliminated, please contact the GAC Motor authorized shop for inspection.

- If the indicator lamp (👁) flashes red continuously, it indicates that the EPB is partially engaged/disengaged or the system is malfunctioning.
- If the indicator lamp (👁) comes on in red when EPB is not applied, it indicates that the system is abnormal.
- If the indicator lamp (👁) comes on in yellow, it indicates that a fault is detected in EPB and the EPB is degraded.

### CAUTION

Do not use dynamic emergency braking unless necessary, as it is likely to cause traffic accidents. Moreover, the braking distance is longer than braking by depressing the brake pedal, and the service life of the parking brake system will be shortened.

### NOTE

- If you pull up the EPB button when the vehicle is running, the instrument cluster display will give a visible warning tell-tale together with an audible beep alarm.
- If you release the EPB or depress the accelerator pedal during dynamic emergency braking, the EPB will be released. If the EPB button is pulled up until the vehicle stops, the EPB will remain engaged.

### AUTO HOLD

#### On and Off

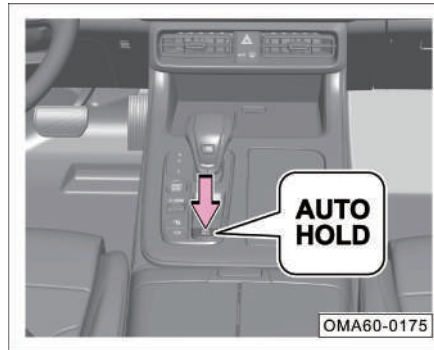

- When the engine is started, the driver's door is closed and the driver's seat belt is fastened, press the AUTO HOLD button. Then, the button indicator lamp comes on, and the AUTO HOLD is enabled. Press this button again. The button indicator lamp goes out, and the AUTO HOLD is disabled.

#### Activation

When this function is enabled, it supports automatic brake application and release under stop & go conditions. When the driver brakes the vehicle, the vehicle will be automatically parked to avoid slide at startup.

#### Exit

Under the following conditions, AUTO HOLD will be disabled and the parking brake will not be locked:

1. The accelerator pedal is depressed at startup.
2. The engine stops while the vehicle is running.
3. The EPB is manually released.
4. The AUTO HOLD button is pressed when the brake pedal is depressed.

## 5. Driving guide

For the sake of safety, the AUTO HOLD will be disabled and the parking brake will be locked under one or more of the following conditions:

1. The vehicle is powered off.
2. The driver's door is opened or the seat belt is unfastened when the vehicle is stopped.
3. The AUTO HOLD button is pressed to disable AUTO HOLD.

### CAUTION

When driving into a mechanism such as a vehicle washing device that transports the vehicle with a conveyor belt, be sure to disable the AUTO HOLD, otherwise the vehicle cannot move or may run off the path.

## 5.3 Electronic service brake system

### 5.3.1 Electronic stability program (ESP)

ESP can effectively reduce the risk of sideslip.

ESP determines the driving intention of the driver according to the steering wheel angle and the vehicle speed, and compares it with the actual driving condition of the vehicle continuously. If the vehicle deviates from the normal driving route (such as sideslip), ESP will correct it by applying brake force to the corresponding wheels.

ESP restores the vehicle to a stable driving state via the torsional force generated by braking.

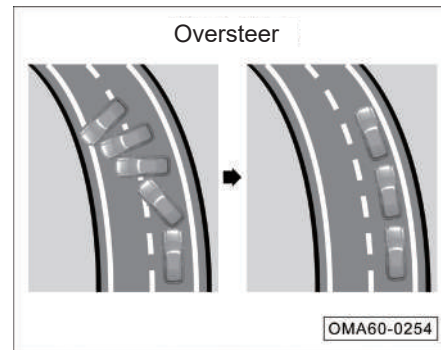

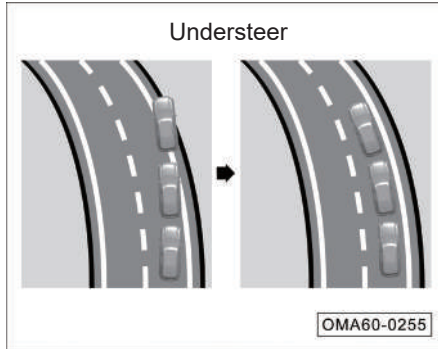

- When the vehicle tends to oversteer (i.e., drift), the system will apply braking force mainly to the front wheel on the outer side of the curve.



- When the vehicle tends to understeer (i.e., excessive turning radius), the system will apply braking force mainly to the rear wheel on the inner side of the curve.
- A vehicle without ESP deviates from the normal driving route due to sideslip. A vehicle with ESP can correct the braking force according to sideslip, to prevent deviation from the route.

### On and Off



ESP is on by default when the vehicle is running. Access the AV system interface, click the driving control panel button  on the bottom toolbar to enter the driving control panel interface. If the “ESP” soft key is clicked, the ESP will be deactivated, the indicator lamp  on the instrument cluster will come on and an alarm message will be displayed.

Since the electronic stability program (ESP) works only when the vehicle is running, the ESP shall be activated for driving safety. The ESP can be disabled in the following special cases:

- When the vehicle runs with tire chains.
- When the vehicle runs on roads covered with deep snow or on soft grounds.
- When the vehicle is trapped on muddy roads, etc., and you need to move it back and forth.

### CAUTION

Improper operation or modifications (such as modifications to the brake system, wheels, tires and other components) of the vehicle will affect the function of ESP.

## 5. Driving guide

---



### WARNING

- **Be sure to adjust the vehicle speed according to weather, road and traffic conditions at any time. Never risk driving merely by virtue of the additional safety functions provided by the systems.**
- **ESP cannot overcome the physical limit of road adhesion; be careful while driving the vehicle on a wet and slippery road or with a trailer coupled.**
- **The driver should adjust the driving style at any time according to the road and traffic conditions.**
- **ESP cannot reduce the risk of accidents caused by improperly driving such as driving at a high speed or driving too close to the vehicle in front.**

### Traction control system (TCS)

TCS refers to traction control system. It determines if the driving wheel slips based on the speed of the driving wheel and the drive wheel, and if the former exceeds the latter, it will limit the speed of the driving wheel. When the vehicle brakes on a smooth road, the wheels will slip, even making the direction out of control. Likewise, when the vehicle starts or accelerates rapidly, the driving wheel may also slip, and the direction may be out of control on a smooth road covered with ice, snow, etc. The TCS is used to automatically control the driving force during vehicle acceleration, so as to keep the slippage of tires within a reasonable range and maintain the driving stability of the vehicle.

### 5.3.2 Anti-lock braking system (ABS)

Anti-lock brake system (ABS), is an active safety device. When the vehicle is braking, if the front wheels are locked, the vehicle will be unable to make a turn. In this case, steering maneuvers necessary for the driver to avoid obstacles and pedestrians during braking and for driving on curves cannot be achieved. If the rear wheels are locked, the braking stability of the vehicle will be deteriorated, and the vehicle will drift or even turn around under the influence of small lateral force (such as lateral wind force). In addition, when the wheels are locked, local severe friction of tire will significantly shorten the tire life.

For anti-lock brake system (ABS) installed on the vehicle, an electronic control unit is added to the original brake system of the vehicle. Its function is to automatically adjust the wheel braking force and prevent the wheels from being locked during braking, so as to obtain the best braking performance and greatly improve the driving safety.



### Advantages of ABS

- Give full play to the effectiveness of brakes and shorten the stopping time and distance.
- Effectively prevent the vehicle from sideslip and drift during emergency braking, delivering good driving stability.
- Achieve steering during emergency braking, delivering good steering control.
- Avoid severe friction between tires and the ground, reducing the wear of tires.
- ABS is composed of anti-lock electronic control system and ordinary brake system. The anti-lock electronic control system consists of the sensor, the control unit and the actuator.

### Self-diagnosis of ABS

- The ABS ECU has self-diagnosis and fail-safe protection functions. When the vehicle power switch is set to "ON" position, ABS performs self-test. If ABS does not run normally, the ABS indicator lamp (ⓘ) will stay on. In this case, stop the ABS, restore normal braking, and go to the GAC Motor authorized shop for inspection as soon as possible.

#### WARNING

**Be sure to adjust the vehicle speed according to weather, road and traffic conditions at any time. Never risk driving merely by virtue of the additional safety functions provided by the systems.**

#### CAUTION

- Improper operation or modifications (such as modifications to the brake system, wheels, tires and other components) of the vehicle will affect the function of ABS.
- Tires must be of a specified size. Incorrect tire size or inconsistent sizes of all tires will affect the normal working of ABS.

### Electronic brake force distribution (EBD)

As a part of ABS, the electronic brake force distribution (EBD) balances the distribution of braking force on the front and rear wheels according to the vehicle load during normal braking.

### Hydraulic brake assist (HBA)

Hydraulic Brake Assist (HBA) is capable of assisting a driver in braking a vehicle under an emergent condition. It determines whether it is necessary to carry out full braking based on the speed at which the driver depresses the brake pedal. As long as the driver depresses the pedal to the floor all the time, the HBA will automatically increase the braking force to the threshold at which the ABS is activated. If the driver releases the brake pedal, the HBA will reduce the braking force to the specified value.

#### WARNING

**HBA is only an assist system for improving the driving safety, but it is subject to the limitation of the laws of kinematics. Therefore, please adjust the driving speed according to the road conditions and traffic regulations.**

## 5. Driving guide

### 5.3.3 Hill hold control (HHC)

The hill-start hold control (HHC) is an active safety system from software function extension on the basis of ESP, which is mainly used to help the driver to pull away successfully on a steep slope.

When the vehicle is stationary, the HHC detects whether the vehicle is on a slope through the longitudinal acceleration sensor. Subsequently, when the vehicle goes up the slope from the stationary state (through forward traveling or reversing), the HHC will automatically enter the working state. At starting, when the driver releases the service brake pedal, the HHC will maintain the previous brake pressure to ensure that the vehicle still stops and gradually reduce the brake pressure with the increase of driving torque to realize the effect that the vehicle does not slide in the opposite direction without parking braking applied, which greatly improves the vehicle starting on a slope, frequent stops, starting, parking, etc.

At starting on a slope, the HHC prevents the vehicle from sliding backwards in the interval between the driver releasing the brake pedal and depressing the accelerator pedal, thus improving the safety and reliability of the vehicle during starting on a slope.

#### Working conditions



- The accelerator pedal is not depressed.
- The vehicle is stationary.
- The EPB is not applied.
- On the premise of meeting the above basic conditions, if the driver depresses the brake pedal with the vehicle stopped, the HHC is activated.

### 5.3.4 Hill descent control (HDC)

The Hill Descent Control (HDC) is a subsystem of ESP. If the driver does not depress the brake pedal while going downhill, HDC helps the driver to decelerate while going downhill via the ESP actively applying braking force.

#### On and Off



- With the vehicle power switch set to “ON” position, access the AV system interface, click the driving control panel button  on the bottom toolbar to enter the driving control panel interface, and click the “HDC” soft key to activate the HDC. When the HDC is working, the corresponding indicator lamp  will stay on or flash, and a message reading “HDC is working”

will be shown on the instrument cluster display. If the HDC is faulty, the buzzer will sound, and an alarm message reading "Please check HDC" will be shown on the instrument cluster display.

- Press the button again to deactivate the HDC, and then the indicator lamp  goes out.

If the HDC function has been activated, the vehicle runs and maintains at the speed of at least 8 km/h while going downhill.

In addition, the driver can adjust the vehicle speed by depressing the accelerator pedal or the brake pedal. If the vehicle speed is within 8-35 km/h when the pedal is released, HDC will be activated again to keep the vehicle going downhill at the current speed.

- When the vehicle speed is higher than 60 km/h, HDC is automatically deactivated.
- When the HDC is active, ESP automatically intervenes in driving if the wheels slip excessively.

### NOTE

- When the HDC has a fault, the function is deactivated and a graphic prompt is displayed on the instrument cluster display with an audible alarm lasting for about 5 s. In this case, HDC cannot work properly, and the driver should depress the brake pedal for deceleration instead of trying to use the system to go down a steep slope. In addition, the driver should go to the GAC Motor authorized shop for inspection as soon as possible.
- In some special environments, the HDC enters the thermal protection mode due to too high braking temperature. For example, when the system operates at a high ambient temperature for a long time, the temperature of the brake system constantly increases due to friction. When the upper limit of temperature has been reached, the HDC enters the thermal protection mode (i.e., the HDC function is active but inoperative) and is temporarily deactivated, and the vehicle shows signs of acceleration. When the temperature of the brake system drops to the level where the brake system can work effectively, HDC resumes normal operation.

### 5.3.5 Hydraulic boost failure compensation (HBC)

When the vacuum booster fails, the HBC can compensate for the temporary low vacuum pressure caused by the vacuum failure and increase the brake pressure. Meanwhile the instrument cluster will display the alarm message. In this case, please contact the GAC Motor authorized shop for inspection as soon as possible.

## 5. Driving guide

### 5.4 Driver assistance systems

#### 5.4.1 Cruise control\*

The cruise control allows the car to run without depressing the accelerator pedal at the set car speed of 40~120 km/h.

#### WARNING

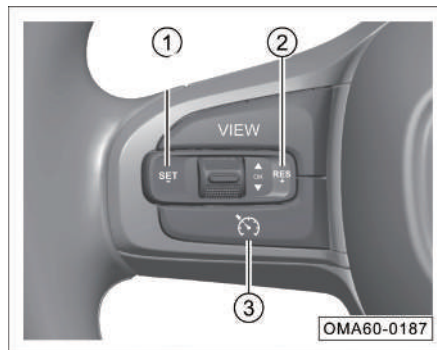

- The cruise control shall be used with caution. After setting the vehicle speed, ensure that the vehicle maintains a safety distance from the lead vehicle.
- The cruise control shall be used with caution. After setting the vehicle speed, ensure that the vehicle maintains a safe distance from the lead vehicle.
- After exiting the cruise control mode, deactivate the cruise control in time.
- The cruise control is only used as an assist for driving and cannot replace automatic driving, so the driver must be vigilant to drive and control the vehicle.

#### Control buttons



- ① SET/-: activating the cruise control/ decelerating
- ② RES/+ : resuming the cruise control/ accelerating
- ③ : activating/deactivating the cruise control

#### Activating cruise control

- If the  button is pressed, the cruise control will be enabled, and the indicator lamp  on the instrument cluster will come on in white.
- Increase the vehicle speed above 40 km/h.
- If the SET/- button is pressed, the indicator lamp  on the instrument cluster will turn green, and the vehicle will enter the cruise control status. After that, release the accelerator pedal.

#### Deactivating cruise control

The cruise control can be deactivated as follows:

- Depress the brake pedal.
- Press the button  (after this, the set vehicle speed will be cleared).
- Activate the ESP.
- Set the gearshift lever to “N” position.

### Resuming cruise control

When the brake pedal is depressed, the indicator lamp  on the instrument cluster will become white, and the cruise control can be reset by pressing the RES/+ button:

- When the vehicle speed is higher than 40 km/h, if the RES/+ button is pressed, the indicator lamp  on the instrument cluster will turn green from white, and the vehicle speed will return to the value set during the last cruise control.

### Increasing cruising speed

- Press the RES/+ button; each time the button is pressed, the vehicle speed increases by 1.0 km/h.
- Press and hold the RES/+ button to increase the vehicle speed continuously until the button is released.

### NOTE

- The maximum setable cruising speed is 120 km/h. When the vehicle speed is higher than 120 km/h, it cannot be adjusted by the RES/+ button.
- When the accelerator pedal is depressed for acceleration, the vehicle will temporarily deactivate the cruise control and run at the increased speed; after the accelerator pedal is released, the vehicle will resume the cruise control.

### Decreasing cruising speed

- Press the SET/- button; each time the button is pressed, the vehicle speed reduces by 1.0 km/h.
- Press and hold the SET/- button to decrease the vehicle speed continuously until the button is released.

### NOTE

When the vehicle speed is lower than 40 km/h, it can no longer be adjusted by the SET/- button.

### 5.4.2 Adaptive cruise control (ACC)\*

The adaptive cruise control, abbreviated to ACC, can automatically adjust the distance from the vehicle ahead in the cruise control mode, for which the applicable cruising speed is 0~130 km/h.

ACC detects the relative distance and speed with the vehicle ahead on the same path according to the signals from the radar installed on the front of the vehicle and the IFC installed on the windshield.

- If a vehicle ahead is stopped, ACC controls the vehicle to stop automatically; if the vehicle ahead is started, ACC controls the vehicle to start again automatically within a short time. After stop for a period of time, the vehicle can be started by setting the multi-function “OK” button upward or depressing the accelerator pedal as the vehicle ahead is started.
- When the speed of vehicle ahead is lower than the target speed set by the driver, ACC controls your vehicle at a safe distance from the vehicle ahead.
- When no vehicle is in front, ACC controls your vehicle to travel at the target speed set before.

## 5. Driving guide

### **i** NOTE





Precautions for use of radars and cameras.  
=> See page 204

### **⚠** WARNING

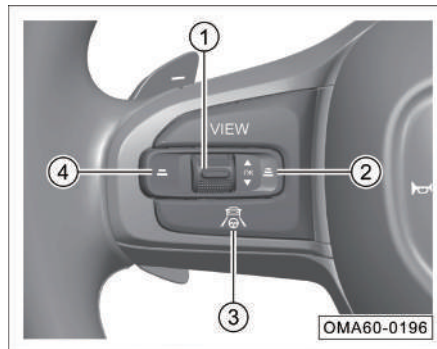
- ACC is not a safety system, obstacle detector, collision alarm or anti-collision system, but a comfort system, so the driver must always keep control of the vehicle and take full responsibility for the vehicle.
- The ACC system must be used cautiously according to the visibility, weather conditions, road and traffic conditions at the time. The driver must always keep control of the car and take full responsibility for the speed of the car and the distance from other vehicles.
- ACC cannot substitute for driver's attention and judgment. The driver should always be responsible for ensuring that the car travels safely at an appropriate speed and maintains an appropriate distance from other vehicles.

### Control buttons





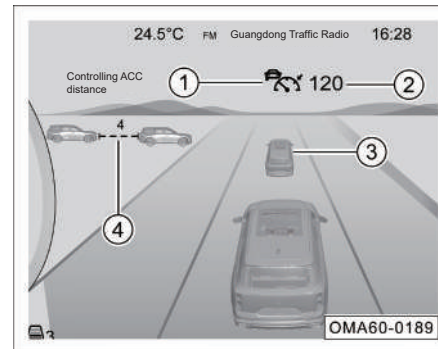

- ①  : multi-function "OK" button
  - resetting ACC/acceleration (by moving up)
  - confirmation/setting (by pressing)
  - deceleration (by moving down)
- ②  : headway increasing button
- ③  : activating/deactivating ACC (by pressing)/switching the cruise mode (by pressing and holding)
- ④  : headway decreasing button

### Interface description



When ACC is activated, the instrument interface automatically jumps to the Intelligent driving theme. In the intelligent driving theme interface, buttons on the left side of the steering wheel respond as follows:



- ① ACC indicator lamp:
  - If the gray ACC indicator lamp  comes on, it indicates that ACC is in the suppression or ready state, and there is a target vehicle ahead; if the blue ACC indicator lamp  comes on, it indicates that ACC is working, and there is a target vehicle ahead.
  - If the gray ACC indicator lamp  comes on, it indicates that ACC is in the suppression or ready state, and there is

no target vehicle ahead; if the blue ACC indicator lamp  comes on, it indicates that ACC is working, and there is no target vehicle ahead.

- If the yellow ACC indicator lamp  comes on, it indicates that ACC is faulty. In that case, go to the GAC Motor authorized shop for inspection in time.
- ② indicates the stored cruising speed.
- ③ indicates the detected vehicle ahead.
- ④ indicates the set cruising distance from the vehicle ahead.

When the braking capacity of ACC is not enough to maintain a proper distance from the vehicle ahead, ACC will send a message reading "Please take over the steering wheel immediately", and the instrument cluster will give a visible alarm and an audible alarm. In this case, the driver shall depress the brake pedal to reduce the vehicle speed according to the system requirements.

### Activating ACC

- If the button  is pressed, the corresponding blue indicator lamp  on the instrument cluster will come on, and the vehicle will enter the ACC status.

### NOTE

- The minimum setable target cruising speed is 30 km/h.
- When the transmission is in other positions than D, ACC cannot be activated.

### Canceling ACC

ACC can be canceled by:

- opening the driver's door.
- unfastening the driver's seat belt.
- Depress the brake pedal.
- setting the gearshift lever to a position other than D.
- pressing the button  (after that, the corresponding indicator lamp on the instrument cluster will turn gray, ACC will be deactivated, but the set speed will be kept).
- pressing the EPB button.
- deactivating the ESP.
- activating the HDC.

If deactivated by the following ways, ACC may be resumed by moving up the multi-function "OK" button:

- depressing the brake pedal.
- pressing the button .
- setting the gearshift lever to a position other than D (the gearshift lever should be moved to D position).
- pressing the EPB button (it is required to release EPB).
- switching off the ESP (it is required to switch on the ESP for resuming the ACC).

## 5. Driving guide



### Resuming ACC

When the corresponding gray indicator lamp on the instrument cluster comes on, ACC can be reset by the following ways:

- moving up the multi-function “OK” button, after which the corresponding blue indicator lamp on the instrument cluster will come on, the vehicle speed will return to the value set during the last cruise, and the cruise control will be resumed.
- If no cruising speed has been stored, ACC will set the current vehicle speed as the cruising speed (if the current vehicle speed is less than 30 km/h, the cruising speed will be set at 30 km/h).





### Increasing cruising speed

To increase the vehicle speed, please operate as follows:

- depress the accelerator pedal to increase the vehicle speed to a target value and move up the multi-function “OK” button  (keep the accelerator pedal depressed) for cruising at the increased speed.
- move up the multi-function “OK” button  for a short time to increase the vehicle speed by 5 km/h each time.
- move up the multi-function “OK” button  for a long time to increase the cruising speed at an increment of 5 km/h until the button is released.

### Decreasing cruising speed

To reduce the vehicle speed, please operate as follows:

- move down the multi-function “OK” button  for a short time to decrease the vehicle speed by 5 km/h each time.
- move down the multi-function “OK” button  for a long time to decrease the cruising speed at an increment of 5 km/h until the button is released.
- during the cruising process, press the button  of steering wheel (with ACC deactivated), make the vehicle coast or slightly depress the brake pedal until the target speed is reached, and press the button  to cruise at the target speed.

### i NOTE



- The maximum cruising speed that can be set is 130km/h.
- When the accelerator pedal is depressed for acceleration, the vehicle will temporarily deactivate the cruise control and accelerate according to the driver’s intention; after the accelerator pedal is released, the vehicle will resume the ACC and the set cruising speed.

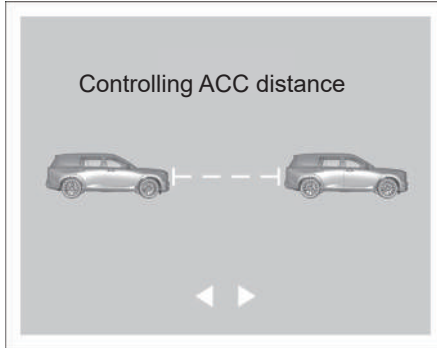

### Controlling ACC distance





After the vehicle power switch is set to “ON” position, when ACC is activated, the default distance setting is in the fourth range (the following distance in the fourth range is the farthest).

By pressing the button  , the distance setting can be changed in the order of “first range → second range → third range → fourth range” and “fourth range → third range → second range → first range”. At the same time, the instrument cluster will display the same number of cross bars as the ordinal number of the range.

### Activating ACC after following stop

When following a vehicle ahead, your vehicle will also be stopped if the vehicle ahead is stopped. During a certain period after such stop, ACC will keep your vehicle stationary by active pressurization of ESP; after this period, ACC will keep your vehicle stationary by activating EPB. When the vehicle in front drives off, the ACC may be activated as follows:

1. If the blue ACC indicator lamp  comes on, ACC can be reset actively and re-drive the vehicle after the vehicle ahead is driven off.
2. If the gray ACC indicator lamp  comes on and EPB is not activated, the instrument cluster will display the message “Waiting for ACC”; if there is a vehicle ahead, ACC can be reactivated by moving up the multi-function “OK” button or depressing the accelerator pedal; if there is no vehicle ahead, for the sake of safety, ACC can be reactivated by depressing the accelerator pedal.
3. If the gray ACC indicator lamp  comes on and EPB is activated, ACC may be reset and re-drive the vehicle by releasing EPB first and then moving up the multi-function “OK” button.

### System limitations

ACC is subject to limitation of physical laws, and thus in some driving environments, the driver may feel a response lag of ACC or may fail to control the vehicle as expected; therefore, the driver must always be ready to take over the vehicle.

The following conditions will affect functions of the radar, so the driver must be particularly alert under these conditions:

1. Decelerating to stop. If a vehicle ahead is stopped by emergency braking, ACC will also decelerate your vehicle or send a hands-on operation request. The driver should actively intervene in the brake according to the hands-on operation request to stop your vehicle completely.

## 5. Driving guide

---

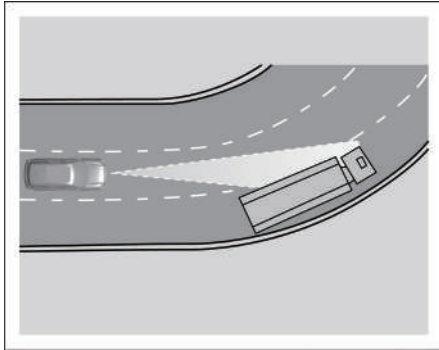

2. Driving through a curve. During driving through a curve, the radar or camera may fail to capture the vehicle ahead in this lane, or may react to vehicles in adjacent lanes. In this case, ACC may not respond to the vehicle ahead, or may brake the vehicle to reduce the vehicle speed. ACC can be exited by depressing the brake pedal or manually deactivating ACC.

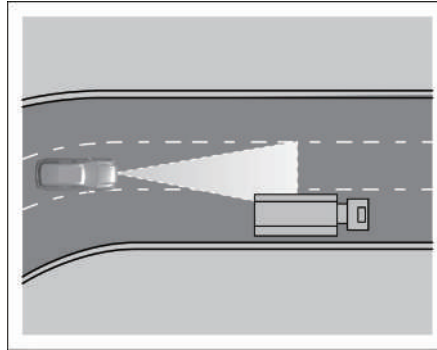

3. Driving out of a curve. During driving out of a long curve, as ACC will calculate the lane in advance, the radar may respond to the vehicles in adjacent lanes and apply the brake of your vehicle. This braking process can be interrupted by depressing the accelerator pedal.

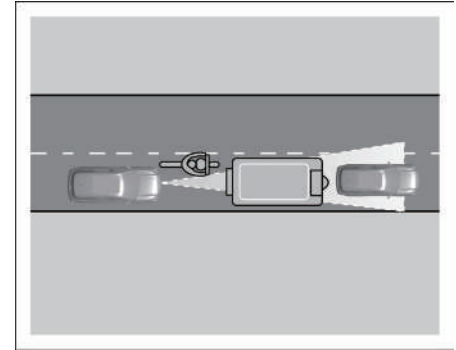

4. Narrow vehicles and Z-shaped traffic in front. The narrow vehicles and Z-shaped traffic in front can be detected by the radar sensor only when they enter the detection range of the radar sensor. That is to say, the system cannot identify vehicles out of the detection range of the sensor. ACC may be unable to identify narrow vehicles such as motorcycles, and has a risk of failing to accurately identify the distance from modified vehicles and vehicles involving non-standard transportation in front, so it is not recommended to take such vehicles as the target vehicle ahead.

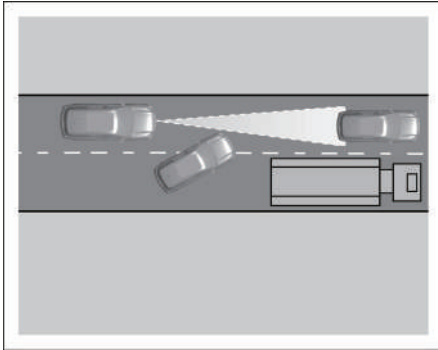

5. When another vehicle changes the lane. When a vehicle in the adjacent lane moves into the lane in which your vehicle travels, the front radar may fail to detect it if it is not in its detection range, thus resulting in a response lag of ACC.

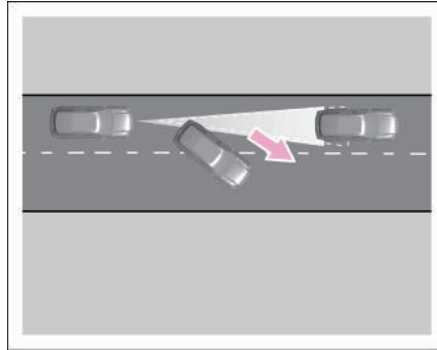

6. If the target vehicle in front is driven out suddenly and a stationary vehicle appears at close range, the radar sensor and brake actuator will incur a response lag, causing delayed braking response.

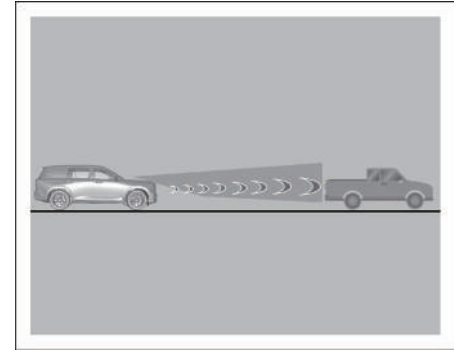

7. ACC should not be used in cities with traffic jams and poor visibility (night/backlighting/rain/snow/dense fog, etc.). ACC may not take braking measures in face of people, animals, narrow vehicles such as bicycles, motorcycles or electromobiles, drop frame trailers, approaching or stationary vehicles, and low-speed or stationary trucks/small pickup trucks, so the driver should be particularly alert and always be ready to take over the vehicle.

## 5. Driving guide

---

8. Influencing factors that may deteriorate the sensor function:
  - Heavy rain, water mist, ice, snow or sludge may deteriorate the function of the radar sensor. As a result, ACC is deactivated temporarily. Meanwhile the instrument cluster displays the following text messages: "The forward radar is blocked" and "Cruising conditions are not met". At this time, ACC and FCM are unable to play their roles.
  - Frosting or fogging of front windshield due to temperature difference or frost in low-temperature and alpine areas, which will obstruct the camera sensor, and cause display of following telltales on the instrument cluster: "The view of IFC is obstructed" and "Cruising conditions are not met". At this time, ACC and FCM are unable to play their roles.
9. Brake overheating. If the brake is overheated due to emergency braking or driving down a steep slope, ACC will be deactivated automatically, and meanwhile the instrument cluster will display a tell-tale reading "Cruising conditions are not met". After that, ACC can no longer be activated, until the brake temperature drops to a reasonable degree.



### WARNING

- **The adaptive cruise control (ACC) function cannot cover all driving scenarios and traffic, weather and road conditions.**
- **The function of ACC is only to supplement the driving assistance function, and cannot replace your attention and judgment. It is your responsibility to maintain a safe distance and speed, and you must be ready to intervene if the ACC fails to maintain a proper speed or distance from the vehicle ahead.**
- **For the sake of safety, do not use ACC under conditions such as urban driving, traffic jams, multi-curve roads and poor road conditions (e.g. icing, fog, gravel, heavy rain, and phenomena prone to water skiing).**

### WARNING

- Do not activate ACC during driving in roadless areas or on earth roads. ACC can only be activated on flat roads paved with pitch, cement, etc.
- The takeover indication alarm of ACC only warns the driver of vehicles detected by its radar and camera sensors, so ACC may not send an alarm, or may send an alarm with a certain delay. Therefore, the driver shall apply the brake as required instead of waiting for the AEB system to operate.
- The adaptive cruise control (ACC) is not a collision avoidance system. If your vehicle is getting closer and closer to the vehicle ahead at a speed higher than that of the vehicle ahead and the braking effect of ACC is unable to stop the vehicle safely before a collision with the vehicle ahead, the driver must depress the brake pedal to reduce the vehicle speed.

### WARNING

ACC will make no or limited response to the followings:

- large speed difference with the vehicle ahead.
- driving on different roads, lane changes or driving on curves with small radius.
- pedestrians, animals, bicycles, tricycles, stationary vehicles or unexpected obstacles.
- complex traffic conditions.
- oncoming traffic or cross traffic.
- low trailers or trucks, and vehicles with irregular or non-standard characteristics.

Therefore, be sure to notice traffic conditions and respond accordingly. Do not wait for the system to identify the target or apply the brake, but apply the brake as needed.

### NOTE

- Do not bump the radar sensors. If the sensor is misaligned due to bumps, it will deteriorate the system performance and even cause the system shutdown even through maintenance and correction are made.
- If the surface of the radar or camera sensor is dirty or covered by heavy rain, ice, snow, sludge, etc., ACC may not function, and the instrument cluster will display the message "The forward radar is blocked" and "The view of IFC is obstructed". After the dirt is cleaned off the sensor surface, ACC will return to normal.
- Do not spray the front bumper with vehicle paint without permission, otherwise the performance of the frontal radar may be degraded.
- ACC may not respond to people, animals and vehicles crossing or approaching the vehicle in the same lane.

## 5. Driving guide

---

### i NOTE

- When driving through crossroads, speed bumps, steep roads and zebra crossings, or at changing lanes, highway access, ramps or construction sections, it is required to exit ACC for manual driving, lest the vehicle should be automatically accelerated to the set speed, causing traffic accidents.
- ACC can automatically drive the vehicle out after a short stop or confirmation from the driver (control of buttons or accelerator pedal). During this period, the driver must ensure that there are no obstacles or other traffic participants such as pedestrians or bicycles in front of the vehicle.
- If ACC fails to function properly, stop using it, and go to the GAC Motor authorized shop for inspection in time.

### i NOTE

- ACC may not respond under certain circumstances. For example, when your vehicle approaches a stationary obstacle such as a broken-down vehicle or a vehicle stuck in traffic jams, or when a vehicle traveling in the same lane approaches your vehicle.
- ACC can only provide limited braking force, and thus cannot be used for emergency braking.
- Prevent placing your foot on the accelerator pedal when not required; otherwise, ACC cannot function for braking, as the depressing of accelerator pedal will cause excessive control of vehicle speed and distance.
- When the vehicle is traveling in heavy rain or snow such that ACC is difficult or unable to identify the vehicle ahead, it is required to switch off the ACC.

### i NOTE

- When ACC is turned on, its status displayed on the instrument cluster display may be overwritten by other functions (for example, during a telephone call).
- When ACC brakes the car automatically after activation, there will be a sound different from manual braking sounds or the brake pedal will be depressed automatically, which is normal. Such sound and pedal action are caused by the operation of the brake system, so there is no need to worry.
- The stored cruising speed will be deleted after the vehicle is powered off.
- The accelerator pedal can be depressed when required to increase the vehicle speed. After the accelerator pedal is released, ACC will readjust the vehicle speed to the previously set cruising speed.
- If the vehicle enters a tunnel, the radar and camera may enter the blind mode, and ACC may be turned off temporarily.

### 5.4.3 Integrated cruise assist (ICA)\*

Integrated cruise assist is abbreviated as ICA. ICA can automatically adjust the distance from the vehicle ahead during cruise control and keep the vehicle traveling in the middle of the lane (hereinafter referred to as “steering assist”) at the cruising speed of 0~130 km/h.

ACC detects the relative distance and speed with the vehicle ahead in the same path according to the signals from the MMW radar installed on the front of the vehicle and the IFC installed on the front windshield, and detects the lane marking through the IFC.

ICA can improve driving comfort and provide a more relaxing driving experience, such as during long-distance driving in smooth traffic on a highway.

#### i NOTE

Precautions for use of radars and cameras.  
=> See page 204

#### Operation instruction

- On the AV system “Settings→ADIGO Intelligent Driving→ADIGO Driving Assistance→Cruise Assist Mode” interface, select ICA to activate ICA or ACC to deactivate ICA.
- After selected, ICA can be activated according to the operation method of ACC. => See page 159



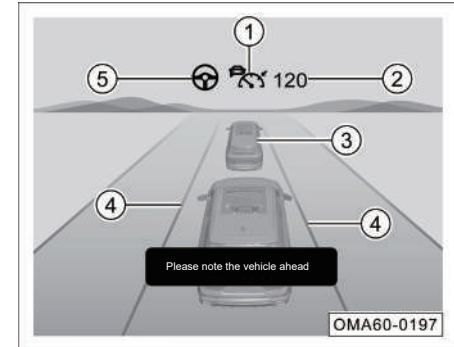

#### i NOTE

- The cruise mode can be changed regardless of the status of ACC, including OFF/ON/Active.
- When ICA has a specific fault not affecting ACC, the cruise mode will automatically jump back to ACC mode. At this time, the driver cannot choose to enter the TJA/ICA mode, but ACC can still be used normally.
- TJA/ICA has cruise mode memory function, so that the cruise mode the same as that before last shutdown will be selected after the engine is restarted.

#### Instrument cluster display interface





#### ① ACC indicator lamp:

- If the gray ACC indicator lamp  comes on, it indicates that ACC is in the ready state, and there is a target vehicle ahead; if the blue ACC indicator lamp  comes on, it indicates that ACC is working, and there is a target vehicle ahead.
- If the gray ACC indicator lamp  comes on, it indicates that ACC is in the ready state, and there is no target vehicle ahead; if the blue ACC indicator lamp  comes on, it indicates that ACC is working, and there is no target vehicle ahead.

## 5. Driving guide

---

- ② indicates the stored cruising speed.
- ③ indicates the detected vehicle ahead.
- ④ indicates a lane marking.
- It will not be displayed if the system fails to detect a valid lane marking, turn gray if the system detects a valid lane marking, and turn blue if ICA is activated or LKA functions. It will turn red if LKA gives an alarm.
- ⑤ indicates an ICA indicator lamp.
- If the gray ICA indicator lamp  on the instrument cluster comes on, it indicates that ICA has been activated and is on standby. In this case, as long as the ACC activation process is followed, the vehicle will activate the ICA and turn on the blue ICA indicator lamp .

The function of ICA is dependent on the lane markings set on a road. When ICA is activated, the ICA indicator lamp may still be gray; if the system detects a valid lane marking, the steering assist will be activated automatically, and the steering assist indicator lamp will turn blue.

Please perform the following operations before activating ICA; otherwise, ICA cannot be activated, and a message reading "The operating conditions of cruise control are not met" will pop up on the instrument cluster. For more precautions for operation, please refer to



section "ACC". => See page 159

- Close all doors properly.
- Fasten the seat belt.
- Set the gearshift lever to D position.
- Release the brake.

### Interrupting steering assist

The steering control of the vehicle by ICA can be temporarily interrupted by the following ways:

- continuously turning the steering wheel.
- turning on the turn signal lamp.
- The hazard warning lamp is turned on.
- manually making a lane change.

When the above operation is performed, the steering assist indicator lamp on the instrument cluster turns gray  from blue , indicating that the steering assist has been deactivated temporarily. After the above operation is stopped, ICA will be resumed automatically when the relevant conditions are met.

### Steering assist

In ICA mode, it will be automatically activated if valid lane markings are detected on both sides and ACC is activated.

ICA will keep the vehicle traveling in the middle between the lane markings on both side.

ICA will be disabled and give a lateral assist function prompt under the following conditions:

- no lane markings on the road or unclear lane markings.
- high curvature of lane marking (before a sharp curve).
- hands-on reminder given by the system when both hands are off the steering wheel for a long time.
- too wide or narrow lanes.
- vehicle speed higher than 130 km/h.



### **i** NOTE

When the steering assist functions, the driver can still turn the steering wheel to control the vehicle. When the torque applied by the system is found improper, the driver can control the vehicle to travel according to his intention when required.

### Hands-on detection and reminder



When detecting that the steering wheel is out of the driver's hands for a long time, ICA will issue a hands-on reminder. In this case, a hands flashing picture  will appear above the ICA indicator lamp, and a message will pop up. If the driver still does not take over the steering wheel, the reminder will be upgraded, and the instrument cluster will display the figure above, accompanied by audible alarm.

The driver shall immediately hold the steering wheel immediately after receiving the hands-on reminder. Don't panic or turn the steering wheel fiercely. After ICA recognizes that the driver is holding the steering wheel by detecting the torque manually applied to the steering wheel, the hands-on reminder

disappears. In this case, ICA is automatically reactivated.

If the driver does not take over the steering wheel within a period of time after a steering wheel hands-on reminder is issued, the steering assist function of ICA will be interrupted.

### **i** NOTE

ICA may mistake driver's hands lightly placed on the steering wheel as hands taken off the steering wheel. In this case, the driver only needs to hold the steering wheel tightly or shake the steering wheel slightly, so that the system can detect the torque applied to the steering wheel. Afterwards the hands-on reminder will disappear.

## 5. Driving guide

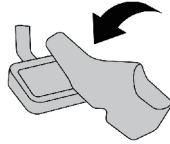

Please take over the steering wheel immediately

OMA60-0199

The braking capacity of service brake system that can be used by ICA is limited, and when ICA requires the driver to intervene in braking, the instrument cluster will give a visible alarm, accompanied by audible alarm.

When receiving the hands-on reminder, the driver shall immediately depress the brake pedal for proper braking.

After the brake pedal is depressed, ICA will be deactivated. If ICA reactivation is required after an emergency is eliminated, press the button  or move up the multi-function “OK” button to reactivate or resume ICA.

### Others

The operation methods of resuming ICA, adjusting the cruising speed, adjusting the following distance, and start after following stop, are the same as that of ACC. For details, please refer to section “ACC” => [See page 159](#)

### Function limitations

The capacity of steering system and brake system that can be used by ICA is limited, and ICA cannot maintain an appropriate distance from the vehicle ahead or keep the vehicle in the lane under all road conditions.

ICA may incorrectly detect lane markings or fail to detect lane markings, or may incorrectly detect target vehicles or fail to detect target vehicles ahead.

Even if enabled and being working, ICA may be affected, malfunction or not function under the following conditions:

- poor line of sight due to rain, snow, rain, sandstorm, etc.
- dirty, damaged or foggy front windshield, or obstruction in the camera area.
- poor line of sight due to direct sunlight, light glare of oncoming vehicles, reflected light from road water-logging, etc.
- dramatic changes in lighting conditions, such as entering/exiting tunnels.
- poor night lighting conditions.
- nonstandard lane markings.
- special lane marking colors, like in construction areas.
- unobvious lane markings, such as too thin, worn, blurred or dirt/braking mark/snow/water-covered ones.
- no lane marking, or lane marking color similar to road surface or curb color.
- Isolation strips or other objects casting shadows on lane markings.
- close distance from the vehicle ahead or partial or all lane markings blocked by the vehicle ahead.
- lane markings blocked by construction facilities, etc.
- marks or objects similar to lane markings on roads, such as braking marks, other signs on road surfaces, curbs and lane seams.
- increase or decrease in lanes.

- complicated routing of lane markings.
- More than two lane markings on the left and right sides of the vehicle.
- Too wide or narrow lanes.
- short-term change of marking, such as ramp entrance and exit.
- high curvature or dramatic change (such as at an S-bend) of lane marking.
- driving on steep slopes or inclined or curved roads.
- bumpy, icy or waterlogged roads.
- Severe shaking of the vehicle.

The speed assist of ICA is the same as that of ACC. For more limitation conditions, please refer to section "ACC" => [See page 159](#).

The lateral assist control performance of TJA/ICA may be affected under the following conditions:

- vehicle overload.
- abnormal tire pressure.
- uneven road.
- strong crosswinds.
- modification of vehicle control-related parts by the driver.

- replacement of vehicle control-related parts with non-genuine parts.
- improper assembly of vehicle control-related parts.

### WARNING

- **The driver should determine whether the traffic environment, etc. are suitable for ICA. Under conditions such as urban traffic, crossroads, water-logged or snowy roads, adverse weather, mountain roads, rough roads and highway access, it is recommended not to use ICA. Do not use ICA when a trailer is coupled.**
- **Improper use of ICA or negligence may lead to accidents. The driver always takes full responsibility for driving, even when ICA is working.**
- **The driver shall always be responsible for compliance with traffic safety codes and safe and civilized driving, even when ICA is working.**

### WARNING

- **ICA only provides a driving assistance function and cannot address all road, traffic and weather conditions. The driver always takes full responsibility for driving, and shall always check the road conditions and actively control the vehicle.**
- **Before using TJA/ICA, the driver must read through all sections about this function in the User Manual to understand the system limitations.**
- **TJA/ICA is not a collision avoidance system. When TJA/ICA does not take proper control, the driver must intervene.**
- **ICA cannot cope with all driving conditions or replace the driver. The driver must hold the steering wheel all the time to actively control the vehicle. When ICA does not provide proper assist or provides improper assist, the driver shall intervene timely.**

## 5. Driving guide

### WARNING

ICA has limitations. Example:

1. ICA may wrongly identify or even don't identify a lane marking due to bad weather, damaged lane markings, etc., and thus it may not generate steering assist or may generate unnecessary steering assist by mistake when needed.
2. The capability of steering system that can be used by ICA is limited, so it cannot cope with all driving conditions.
3. ICA cannot address all traffic conditions. For example, the lateral assist may be suddenly exited under road conditions such as high curvature of lane marking before a sharp curve, and roads without lane markings.

### 5.4.4 Forward collision mitigation (FCM)\*

The FCM assesses the danger level of pre-collision by detecting the relative distance and speed with the vehicle ahead in the same path according to the signal from the MMW radar installed on the front of the vehicle and the IFC installed on the front windshield and the driver's other operations (such as depressing the brake pedal or accelerator pedal), gives an alarm to remind the driver to take measures in time in case of a collision risk, and applies the brake automatically when an impending collision is detected. When the driver is braking while the braking force is insufficient to avoid a collision, the system will automatically increase the braking force to avoid or alleviate the collision.

Detectable objects:



- vehicles
- two-wheelers
- pedestrians

### NOTE

Refer to precautions for use of radars and cameras. => See page 204

### FCW

FCW issues an alarm for impending collision to alert the driver by detecting objects ahead according to the signal from the MMW radar installed on the front bumper and the IFC installed on the front windshield.

The FCM alerts the driver by the following three methods:

#### 1. Distance warning

When the distance warning of the FCM is triggered, the FCWS indicator lamp  on the instrument cluster will flash, accompanied by the visual prompt.

#### 2. Proximity warning

When the early of the FCM is triggered, the FCWS indicator lamp  on the instrument cluster will flash, accompanied by the audible alarm and visual prompt.

#### 3. Brake jerk warning

When the vehicle has a high risk of colliding with the moving target vehicle, brake jerk is triggered to remind the driver that the brake shall be applied immediately.

### Active brake assist

When a collision is about to occur, the system will issue an alarm to alert the driver that the vehicle is ready to apply emergency braking according to the signal from the MMW radar installed on the front bumper and the IFC installed on the front windshield, and then will assist in braking and activate the active brake assist function.

### Active braking level

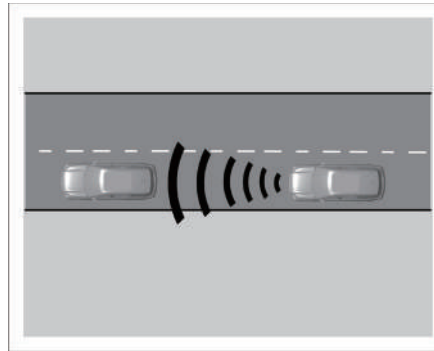

- First-level braking: Brake jerk warning is provided when your vehicle is approaching a vehicle ahead.

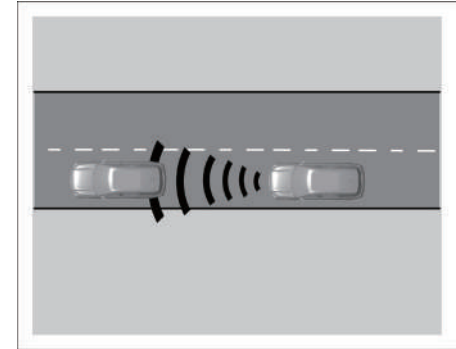

- Second-level braking: Slight automatic emergency braking is applied if your vehicle continues to approach the vehicle ahead after the first-level warning.

## 5. Driving guide

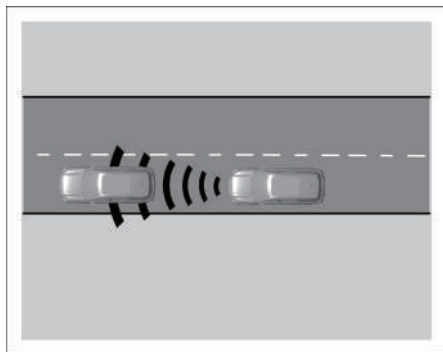

- Third-level braking: Full braking is applied automatically when a rear-end collision is inevitable.

### On and Off



- When the vehicle power switch is set to "ON" position, the forward collision warning and active brake assist functions are activated automatically.
- Go to "Settings → Driving Assistance → Longitudinal Driving Assistance → FCW" in the AV system, and press the  soft key on the right side to activate or deactivate "FCW" or "AEB".
- When FCW or AEB is being deactivated, a reconfirmation window will pop up on the multi-function touch screen. In this case, click "OK" or "Cancel" to confirm the operation.

### i NOTE

- "Far, Medium and Near" can be set via "Settings → Driving Assistance → Longitudinal Driving Assistance → Forward Collision Warning Distance Setting" in the AV system. There is a memory function for the warning distance of the FCW system to remember the last set warning distance.
- After being turned off, FCW and AEB will no longer give an alarm or apply the brake in case of any target vehicle and pedestrian.
- After FCW or AEB is deactivated, they will be activated automatically by default if the vehicle power switch is switched from "OFF" position to "ON" position again.

### System limitations

The FCM is subject to physical and system limitations. For example, the forward collision warning and active brake assist functions may be activated unintentionally or after a certain delay due to intervention by the driver. Therefore, the driver shall stay vigilant and take over control of the vehicle if necessary.

The FCM may work after a certain delay or fail to work when:

- The ground clearance of vehicle ahead is large, such as a semi-trailer.
- The rear of vehicle ahead is low, such as a low bed trailer.
- The vehicle ahead has an irregular shape, such as a tractor or a sidecar.
- The brightness of surrounding environment changes abruptly, such as tunnel entrances and exits.
- The rear of vehicle ahead is small, such as an unladen truck.
- A detectable object ahead performs emergency acceleration, deceleration and steering.
- A detectable object ahead is suddenly driven in front of the vehicle.
- There is a bicycle with a special shape ahead, such as a tandem bicycle.
- The vehicle is driven at a very high speed.
- The vehicle is driven on a slope.
- The vehicle is running on a narrow curve.
- The accelerator pedal is depressed to the floor or the vehicle accelerates quickly.
- The assist function is deactivated or operates abnormally.
- The ESP is manually deactivated.
- The ESP control is activated.
- The surface of area where IFC is located or the radar sensor surface is dirty or covered by foreign objects.
- The vehicle is reversing.
- Traffic is chaotic.
- The vehicle is towing another vehicle.
- A pedestrian is standing on a refuge island or a curve.
- A pedestrian is completely or partially covered by other objects, such as a worker holding a ladder or a pedestrian holding an umbrella.
- A pedestrian is wearing fancy clothes or a mask, such as the carnival costume.
- External conditions such as sunset, night, ice, snow, heavy rain, fog and backlight lower the visibility.
- If a collision is impossible, the system may work when
- There is a detectable object in front of the vehicle.
- The vehicle is overtaking a vehicle that is changing lanes or turning right/left.
- The vehicle is overtaking a vehicle that is ready to turn right/left.
- There is a detectable object at the entrance of a curve.
- The vehicle changes lanes while overtaking a detectable object.
- The vehicle approaches a detectable object ahead while running on a winding lane or changing the driving route.
- The vehicle runs under portal frames, billboards, road signs, etc.
- There are metal objects such as manhole covers and steel plates in front of the vehicle.

## 5. Driving guide

- The vehicle approaches a roadside telegraph pole, railing, tree, etc.
- The vehicle runs over grass, branches, banners and other objects that may come in contact with it.
- The vehicle runs near an object reflecting radio waves.

### WARNING

**The active brake assist function must be deactivated when**

- The vehicle is towed.
- The vehicle is on a chassis dynamometer.
- A radar sensor or camera sensor has a fault.
- An external force (such as a rear-end collision) acts on the radar sensors.

### WARNING

- **FCM can improve the driving safety, but it is still subject to the limitations of laws of physics, and thus shall never be used for risky driving. The driver must always be ready to apply the brake to reduce the vehicle speed or avoid obstacles.**
- The FCM only provides warning and collision mitigation for vehicles/pedestrians detected by the radar and camera, so there may be no response or a certain delay in the response. Therefore, the driver shall apply the brake if necessary instead of waiting for the FCM to operate.
- The FCM only provides the driver with warning to avoid collision and limited braking to mitigate collision injuries, and cannot prevent a vehicle accident or injuries on its own. The driver must always keep control of the vehicle and take full responsibility for the vehicle speed and the distance from other vehicles.

### WARNING

- **When the FCM is activated, the driver shall always keep control of the vehicle during driving and take full responsibility for the vehicle speed and the distance from other vehicles.**
- **Never ignore any suddenly activated warning lamp and reminder displayed on the instrument cluster, otherwise a traffic accident and even serious injuries may occur.**
- **Therefore, the driver shall always observe traffic conditions instead of completely relying on the active brake assist function. As it is only a driver assistance function, the driver shall be fully responsible for keeping a proper distance from the vehicle ahead, controlling the speed and braking in time. The driver must always be ready for braking or steering.**



### i NOTE

- The FCW alerts and the active brake assist function's intervention in braking can be stopped by depressing the accelerator pedal or turning the steering wheel.
- In a complex driving environment (such as traveling on a circuitous road), the FCW and active brake assist functions may give an unnecessary warning and brake the vehicle unnecessarily.
- When the active brake assist function is activated, the vehicle will be braked, and the foot may feel hard or vibration from the brake pedal, which is normal.
- When AEB is negatively affected by the environmental factors (for example, electromagnetic interference or the target itself), the detection function will be interfered and the AEB performance will be degraded.

### 5.4.5 Traffic sign recognition\*

Traffic sign recognition is abbreviated to TSR. TSR provides the driver with speed limit information by detecting speed limit signs ahead on the road through the IFC installed on the front windshield and combining with data from the navigation of the AV system, and alerts the driver to overspeed when the speed limit is exceeded.

#### On and Off



Go to “Settings → Driving Assistance → Longitudinal Driving Assistance” in the AV system, and press the  soft key on the right side of “TSR” to activate or deactivate this function.

When this function is activated, the speed limit sign on the instrument cluster will flash for a period of time if the speed limit sign is displayed on the instrument cluster and the actual speed of the vehicle is slightly higher than the value indicated on the speed limit sign.

### i NOTE

The system has a button state memory function, so that when the vehicle is restarted, the system will work in the state before last shutdown.

## 5. Driving guide

### Description of display interface

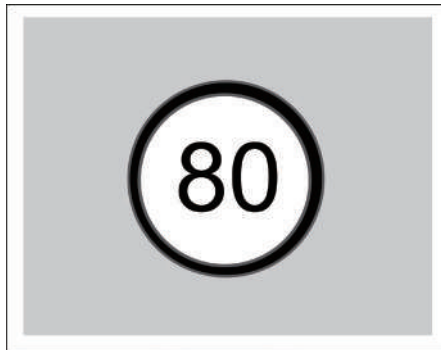

It indicates the recognized road speed limit, covering but not limited to general speed limit signs, combined speed limit signs and divided lane speed limit signs.

When the actual speed of the vehicle is slightly higher than the speed limit indicated by the instrument, the speed limit sign on the instrument cluster will flash for a period of time.

### WARNING

**To avoid interfering with the driver frequently, the overspeed alert will only be triggered once under the conditions of constant road speed limit and continuous overspeed; therefore, the driver shall drive carefully, pay attention to the speed and not rely too much on this function.**

### Deactivating/activating speed alarm sound

Go to “Settings → Driving Assistance → Longitudinal Driving Assistance” in the AV system, and press the  soft key on the right side of “Overspeed Sound Warning” to activate or deactivate this function.

After this function is activated, when the actual speed of the vehicle is slightly higher than the speed limit indicated by the instrument and there is an electronic eye for speed measurement on the current road, except that the speed limit sign on the instrument cluster will flash for a period of time, a speed alarm sound will also be given to remind the driver.

The system has a button state memory function, so that when the vehicle is restarted, the system will work in the state before last shutdown.

### Deactivating/activating intelligent speed limit

Go to “Settings → Driving Assistance → Longitudinal Driving Assistance” in the AV system, and press the  soft key on the right side of “Intelligent speed limit” to activate or deactivate this function.

This function is an auxiliary function of ACC/ICA and only works when ACC/ICA is activated.

After this function is activated, if the road speed limit identified by the system is greater than the current set cruising speed, the system will trigger the following prompt:

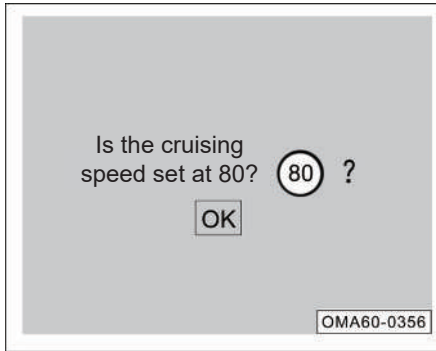

To set the cruising speed according to the current road speed limit, just press the “OK” button on the left side of the steering wheel; in this case, the cruise assist function of ACC/ICA will automatically adjust the set speed. If the driver does not want to modify the set cruising speed, he/she can simply ignore the prompt; in this case, the pop-up window will disappear automatically after a period of time.

### Function limitations

The TSR, even activated, may involve wrong or failed detection of speed limit sign due to inevitable environmental factors and conditions. The system may become affected or inoperative under the following conditions:

- The camera is blocked or disturbed by strong light.
- The headlamp is not turned on or cannot fully illuminate the speed limit sign at night or when the light is low in tunnels.
- The speed limit sign is partially or completely blocked.
- The speed limit sign is worn, blurred or dirty.
- The speed limit sign is not properly placed, such as involving twisting or tilting.
- The speed limit sign is obstructed by vehicles in the adjacent lane or obstacles.
- The speed limit has been changed due to temporary road construction.
- Navigation data is not updated online in a timely manner or accurate.
- Other guide boards are misidentified as speed limit signs due to the non-standard road.

- Road speed limit information for other vehicles is output due to inaccurate navigation and positioning.

### WARNING

- **The TSR can only recognize speed-related signs instead of other signs on the road.**
- **The TSR can only recognize the speed limit for this road. Do not rely on the TSR to determine the appropriate driving speed, but always drive within the safe speed range according to the speed limit and road conditions.**
- **The TSR can only work under some conditions. The driver shall always assume the ultimate responsibility for safe driving and comply with applicable laws and road traffic rules.**

## 5. Driving guide

### 5.4.6 Lane departure warning (LDW) system\*

The lane departure warning system is designed to reduce accidents caused by unintentional lane departure.

The lane departure warning system detects the lane markings on the road through the camera installed on the front windshield, analyzes the driving behavior of the driver and moving status of the vehicle, and gives a warning or interferes with the steering wheel to correct the lane departure when the vehicle unconsciously deviates from the lane due to fatigue, distraction or phone calls of the driver. It usually gives a warning or interferes with the steering wheel when the front wheel crosses a lane marking.

When the driver selects “Steering” or “Steering and Warning” as the LKA mode and the operating conditions of the lane departure warning system have met, the system monitors the torque applied to the steering wheel. When the driver keeps his hands off the steering wheel for a long time, the system will alert the driver.

#### On and Off

Go to “Settings → Driving Assistance → Longitudinal Driving Assistance” in the AV system, and click the  soft key on the right

side of “Lane Keeping Assist” to activate or deactivate this function.

When the function is turned on, the button will be in on state, and the lane departure warning system indicator lamp  on the instrument cluster will come on; when the function is turned off, the button will be in off state, and the lane departure warning system indicator lamp on the instrument cluster will go out.

The system has a button state memory function, so that when the vehicle is restarted, the system will work in the state before last shutdown.

#### Select the LKA mode

With the ENGINE START/STOP button in “ON” position, go to “Settings → Driving Assistance → Longitudinal Driving Assistance” in the AV system to select the lane keeping assist mode.

1. Steering
  - When “Steering” is selected, the system only intervenes in turning of steering wheel for corrective steering adjustment.
2. WARNING
  - When “Warning” is selected, the system only works for alarming.
3. Steering and warning

- When “Steering and Warning” is selected, the system will not only issue a warning but also intervene in turning of the steering wheel for corrective steering adjustment.

#### NOTE

The LDW has the lane keeping assist mode memory function, so the lane keeping assist mode before last shutdown will be selected when the vehicle is restarted.

#### How it alerts the driver

The lane departure warning is only activated when “Warning” or “Steering and warning” has been selected as the LKA mode.

- When the instrument shows a speed greater than 65km/h and the system detects at least one valid lane marking on one side, the indicator lamp  on the instrument cluster turns green, it indicates that the system may issue a lane departure warning in this case. When only the lane marking on one side is detected, the system will only alert the driver to that side.

When the indicator lamp  is green, the system may not issue a warning and the indicator lamp turns white if the vehicle departs from the lane under one of the following conditions.

- The accelerator pedal is quickly depressed.
- The brake pedal is slammed for deceleration.
- The corresponding turn signal lamp is turned on.
- The hazard warning lamp is turned on.
- The driver quickly turns the steering wheel.
- The interval after the last warning is short.
- The vehicle keeps rolling on the lane marking.
- The system alerts the driver to take over the steering wheel because the steering wheel is out of the driver's hands.

When the indicator lamp  is green, if no condition mentioned above happens and the vehicle drifts out of lane (such as due to the driver's fatigue, distraction or phone calls, etc.), the system alerts the driver by flashing the red lane marking on the instrument cluster and audible alarm.

### Steering assist

The corrective steering adjustment indication of lane departure warning system is triggered only when the assist mode is "Steering" or "Steering and warning".

When the instrument shows a speed greater than 65 km/h and the system detects valid lane marking on at least one side,

the indicator lamp  on the instrument cluster turns green. This indicates that the system may intervene in turning of steering wheel for corrective steering adjustment. When only the lane marking on one side is detected, the system only works for lane keeping assist to that side.

When the indicator lamp  comes on green, the system will not implement corrective steering adjustment under one of the following conditions.

The accelerator pedal is quickly depressed.

- The brake pedal is slammed for deceleration.
- The corresponding turn signal lamp is turned on.
- The hazard warning lamp is turned on.
- The driver quickly turns the steering wheel.
- The interval after the last warning is short.
- The vehicle keeps rolling on the lane marking.
- The system alerts the driver to take over the steering wheel because the steering wheel is out of the driver's hands.

When the system intervenes in turning of steering wheel for corrective steering adjustment, the driver can feel the torque applied to the steering wheel by the system and the instrument cluster shows the blue lane marking indication.

### Hands-on reminder



When the lane departure warning system detects that the steering wheel is out of the driver's hands for a long time, the system issues a hands-on reminder while the instrument cluster displays the icon above and an audible alarm is issued.

The driver shall immediately hold the steering wheel immediately after receiving the hands-on reminder. Don't panic or turn the steering wheel fiercely. After the lane departure warning system recognizes that the driver is holding the steering wheel by detecting the torque manually applied to the steering wheel, the hands-on reminder disappears. Meanwhile, the lane departure warning system is automatically reactivated.

## 5. Driving guide

---

### **i** NOTE

The condition that the driver's hands are lightly holding on the steering wheel may be misinterpreted by the system as the steering wheel out-of-hand. In this case, when the system issues a steering wheel hands-on reminder, the driver only needs to hold the steering wheel tightly or shake the steering wheel slightly, so that the system can detect the torque applied to the steering wheel. Afterwards, the hands-on reminder will disappear.

### **Other indications**

When it is detected that the camera is inoperative, a text message reading "The sight of front cameras is blocked" will pop up on the instrument cluster.

Usually, it is caused by dirty windshield glass or the camera directly exposed sunlight. The lane departure warning system will not be damaged on that and it does not need to be overhauled.

The driver may try to clean the front windshield by spraying water on it and activating the windshield wiper.

When a fault is detected, the message reading "Please check the LDW" will pop up on the instrument cluster and the indicator lamp 

turns red. In this case, please go to the GAC Motor authorized shop for inspection in time.

### **Function limitations**

The lane departure warning system may wrongly detect a lane marking or not detect any lane marking at all due to inevitable environmental factors and conditions even if it is activated and working. The system may become affected or inoperative under the following conditions:

- Poor line of sight, such as snow, rain, fog or water spots.
- Dirty or foggy windshield, or obstruction in front of the windshield camera.
- Overtemperature around the camera due to direct sunlight.
- Glare due to direct sunlight, oncoming traffic, reflected light from road water-logging, etc.
- Sudden changes in outdoor brightness, such as entering/exiting tunnels.
- Headlamp not turned on at night or when the light illumination is low in tunnels.
- No lane marking, or difficulty in distinguishing the lane marking color from the road surface color.

- Unobvious, too thin, worn, blurred or dirt/snow-covered lane markings.
- Increase or decrease in lanes, or complicated routing of lane markings.
- More than two lane markings on the left and right sides of the vehicle.
- Marks or objects similar to lane markings on roads.
- Isolation strips or other objects casting shadows on lane markings.
- Short-term change of marking, such as ramp or highway exit.
- Driving on steep slopes or curved roads.
- Close distance from the vehicle ahead or lane markings blocked by the vehicle ahead.
- Severe shaking of the vehicle.

Under the following conditions, the performance of the system may be affected while it intervenes in turning of steering wheel for corrective steering adjustment:

- vehicle overload.
- abnormal tire pressure.
- uneven road.
- strong crosswinds.
- modification of vehicle control-related parts by the driver.
- replacement of vehicle control-related parts with non-genuine parts.
- improper assembly of vehicle control-related parts.

### **i** NOTE

When the lane departure warning system intervenes in turning of the steering wheel for corrective steering adjustment, the driver may still turn the steering wheel to control the vehicle. When the torque applied by the system is found improper, the driver can control the vehicle to travel according to his intention when required.

### CAUTION

- When the lane departure warning system detects an unintentional lane departure, it issues a warning or intervenes in turning of the steering wheel to assist in corrective steering adjustment. Neither panic nor turn the steering wheel fiercely.
- When the lane departure warning system detects that the steering wheel is out of the driver's hands for a long time, it issues a warning. In this case, don't panic, neither turn the steering wheel fiercely or shake the steering wheel. and instead, please hold the steering wheel and drive the vehicle as usual.
- When "Warning" is selected as the LKA mode, the system will not intervene in turning of the steering wheel. When "Steering" is selected as the LKA mode, the system will not issue any visual and audible alarms.

### WARNING

- **The lane departure warning system is just an assist system and cannot actively control the vehicle to change lanes or keep it in the lane. The driver must always check the road conditions, hold the steering wheel and actively control the vehicle.**
- **Improper use of the lane departure warning system or negligence may cause an accident. Do not rely on the lane departure warning system completely or drive the vehicle at risk with the aid of the LKA system.**

## 5. Driving guide

---

### WARNING

- The lane departure warning system is not always able to identify a lane marking and a lane edge. The system may wrongly identify or even don't identify a lane marking or a lane edge due to bad weather, poor night lighting, water or snow on road, damaged or blurry lane markings, or shade on roads.
- If this occurs, missing and false activation of the lane departure warning system may occur, so drivers shall concentrate on observing road and traffic conditions and drive carefully.

### WARNING

- Protect the camera against strong impact, moisture or heat; and never remove and refit any part without authorization. Do not place reflective objects on the instrument panel, which may not only cause dazzling to the driver but also reflect the light to the IFC, causing abnormal operation.
- Do not color or coat the front windshield with any material not meeting the corresponding specifications. Any additional objects that negatively affecting the sight of the system camera may lead to improper operation of the system.
- Lane keep aid system with curb recognition uses signals from millimeter-wave radar sensor. Avoid impact or modification of the bumper or vehicle body; otherwise the LKA system may operate abnormally.

### WARNING

- If the system fails to detect the lane marking or judges that the driver deliberately deviates from the lane (for example, detected fast turning of the steering wheel), or the vehicle speed is not less than 130km/h or not higher than 60km/h, the LDW will not issue a warning or perform steering intervention even if the vehicle deviates or departs from the lane.
- The system can only adjust limited steering angle, so it can't promise that the car will be driven back into the lane under any circumstances.
- The sound inside or the noise outside may prevent you from hearing the warning beep, so you may not notice the warning issued from the LDW system under any circumstances.



### 5.4.7 Shadow driver

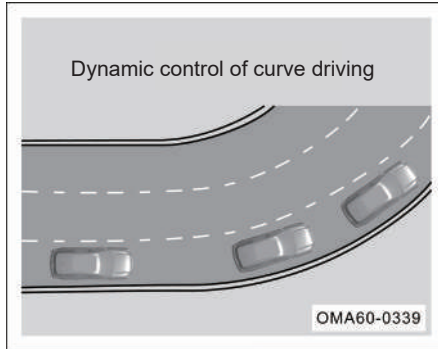

Shadow driver is a kind of adaptive vehicle dynamic control (AVDC for short) technology. It mainly applies slight longitudinal acceleration/deceleration intervention to the vehicle during steering, so as to reduce the lateral acceleration and rolling of the vehicle and reduce the driver's action load of the accelerator and steering wheel, improving cornering stability and driving comfort.



Shadow driver has five modes: Off, Steady, Aggressive, Ice and Snow, and Adaptive. Go to "Driving Mode - Current Driving Mode" on the AV system display to select the corresponding "Shadow driver" mode.

- "Off" mode: the shadow driver function is turned off.
- "Steady" mode: the shadow driver control is moderate and appropriate for regular driving.
- "Aggressive" mode: the shadow driver control is less intense to reduce interference with driver's actions.
- "Ice and Snow" mode: the shadow driver control is strongest. This mode should be used on icy and snowy roads. If it is used on regular roads, the driver's action may be interfered too much.

- "Adaptive" mode: the intensity of the shadow driver is automatically adjusted based on the driver's actions. In this mode, the vehicle automatically adjusts the throttle sensitivity according to the vehicle state and the driver's action.

## 5. Driving guide

---

### CAUTION

- In "Adaptive" mode, the driver cannot adjust the throttle sensitivity.
- For 4WD vehicles, in "Snow mode\*", "Mud mode\*" or "Sand mode\*", the shadow driver function is disabled, the AV system interface is gray, and the shadow driver mode cannot be adjusted.

### Adjustment of throttle sensitivity

Throttle sensitivity is a way to adjust the effects of the throttle, the higher the throttle sensitivity is, the faster the engine torque response is. Generally, low throttle sensitivity is suitable for low speed and congested road conditions, while high throttle sensitivity is suitable for high speed and mountain roads that require high power output.

- When the shadow driver is not in the "Adaptive" mode, the user can set the throttle sensitivity in the "Driving Mode - Current Driving Mode" interface.
- Alternatively, the throttle sensitivity can also be adjusted by setting the multi-function "OK" button upward/downward on the left side of the steering wheel.

### 5.4.8 Intelligent headlight control\*

The intelligent headlight control (IHC) detects the traffic and environmental conditions in real time via the IFC installed on the upper edge of the windshield and automatically switches between the low beam and high beam. For example, if the driver activates the IHC during driving on a road with poor lighting at night, IHC will switch on the high beam automatically when it is detected that the operating conditions of high beam are met; and switches the headlamp from high beam to low beam when a front vehicle is detected close.



### Activating IHC



1. With the ENGINE START/STOP button in "ON" position, go to "Settings → Body Accessories → Lamps" in the AV system, and press the  soft key on the right side of "IHC" to activate this function.

#### i NOTE

The IHC has the memory function, so that it will work in the state before last shutdown when the vehicle is restarted.

2. Turn the lamp switch to AUTO position to switch on the automatic headlamp function.
  - After the intelligent headlight control function is enabled, it is in a standby state. When high beam conditions are not met or the driver does not manually turn on the high beams, the indicator lamp  on the instrument cluster will be white.
  - When the intelligent headlight control function is enabled, if high beam conditions are met, the system will automatically switch to the high beam, and the indicator lamp  on the instrument cluster will turn blue.

### Deactivating IHC

If one of the following conditions is met, turn off the intelligent headlight control function:

- Turn the lamp switch to a position other than AUTO.
- Go to "Settings → Body Accessories → Lamps" in the AV system, and press the  soft key on the right side of "IHC" to deactivate this function.
- Shut down the engine.

#### i NOTE

- The high beam and headlamp flashing light can be manually switched on/off when required.
- In the case of heavy fog, rain, etc., which may cause dazzling to the driver, a request to turn on low beam will be initiated.

### Disabling conditions of IHC

The high beam will be disabled when:

- The driver turns on the high beams manually.
- The vehicle speed is less than 15km/h.
- The fog lamps are turned on.
- The wipers are turned to the HI position for a period of time.
- The ambient light is brighter than the threshold.
- A street light, a near vehicle ahead or an oncoming vehicle is detected.

The high beam will not be actively activated when:

- Driving is violent, turns are sharp, ABS or ESP is activated, etc.

## 5. Driving guide

---

- The vehicle speed is less than 35km/h.
- turning on the turn signal lamp.

### Function limitations

When the IHC is activated, the automatic switching of high beam and low beam may be delayed or even unavailable when:

- The windshield surface in front of the IFC is covered with ice, snow, fog, dirt, sticker or other objects.
- There is highly reflective object on a low-lit street.
- The vehicle meets a pedestrian or a cyclist on a road with poor lighting or on a roadside.
- The light of the front oncoming vehicle is blocked by a crash barrier, a high bow-top road fence, a green belt, etc.
- The brightness of the tail lamps of the vehicle ahead is low or does not comply with national standards when the vehicle is following the vehicle ahead.
- The vehicle meets another incoming vehicle in case of an extremely tight turn/mountain road/low-lying ground.
- The vehicle is running on a slope or a bumpy road.

- The vehicle is running in a heavily rainy, snowy or foggy day.
- The IFC is damaged or its power supply is cut off.

### WARNING

**IHC is a driver assist function, and it can help you to select the lighting way best suitable for the actual condition. The driver shall always be responsible for manual switching between the high and low beams under the traffic and environmental conditions.**

- **The IHC may not be able to correctly identify all driving environments and cannot operate properly in some environments.**
- **If the IFC is blocked by dirt, stickers, ice and snow, etc., the IHC may become inoperative.**
- **If the car's lighting system is modified (for example, the headlights are modified), the performance of the intelligent high beam may be degraded or its function may be inoperative.**

### 5.4.9 Adaptive driving beam system\*

Adaptive driving beam system, referred to as ADB for short, is an intelligent high beam control system that can adaptively change the type of high beam according to road conditions. According to the driving status of the vehicle, the environmental status and the status of other vehicles on the road, the ADB system automatically turns on or off the high beams for the driver; according to the vehicle position in the front view of own vehicle, the high beam type is adaptively changed to avoid dazzling other road users.

### Turn on the adaptive driving beam system



1. With the ENGINE START/STOP button in "ON" position, go to "Settings → Body Accessories → Lamps" on the AV system display, and press the soft key  on the right side of "Adaptive driving beam" to turn on it, so the ADB function enters the standby state. When this function is turned off, the vehicle cannot trigger the ADB function.



2. Turn the lamplight switch to the AUTO position ① and the low beam position. Provided that the ambient brightness is low and the low beam is automatically turned on, if the vehicle speed is greater than 25km/h, the adaptive high beam ADB function is allowed to be activated. At this time, the high beam enters the intelligent control state. If the vehicle speed is lower than 15km/h, the adaptive high beam function will be automatically disabled.

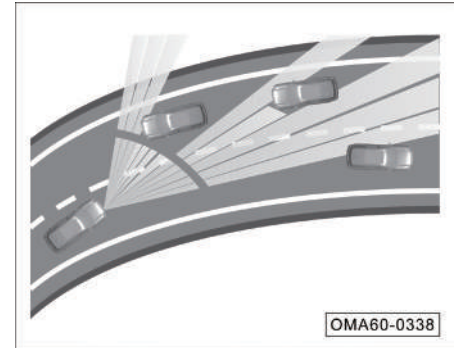

- If the IFC detects that there are rows of street lights on the current road, the high beams will not automatically turn on.
- On roads without street lights, the system will automatically switch the high beam type according to the position of the vehicle ahead to avoid dazzling the driver of the vehicle ahead, while maintaining high beam lighting in other areas.

## 5. Driving guide

### CAUTION

- In inclement weather such as heavy fog (when the user manually turns on the fog lamps) or heavy rain (the wipers are quickly moving), the high beams will not be turned on automatically to ensure driving safety.
- The high beams will not automatically turn on when the parts involved in the function implementation fail or there is a system failure.

### 5.4.10 Blind spot detection (BSD) system\*

The BSD system detects the vehicles in the blind spot and the area behind the blind spot via the sensor installed at the rear of the vehicle. If it detects that another vehicle is approaching quickly, the BSD will alert the driver through the visual signal on the exterior rearview mirrors.

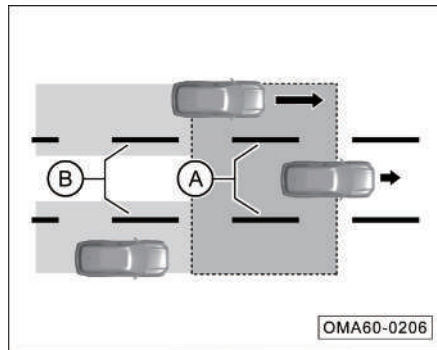

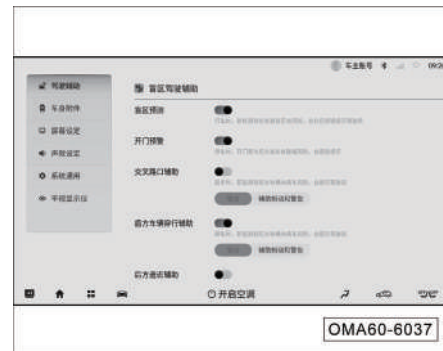

- A: Blind spot in the adjacent lane.
- B: Area behind the blind spot.

### On and Off



With the ENGINE START/STOP button in “ON” position or after the engine is started, go to “Settings → Driving Assistance → Blind Spot Driving Assistance” in the AV system, and press the  soft key on the right side of “BSD” to activate or deactivate this function.

If the BSD system is switched on properly, the indicator lamps on exterior rearview mirrors will come on temporarily, and the indicator lamp  on the instrument cluster will turn green. If a fault is detected in the BSD system, the indicator lamp  will turn red, and a fault indication will be shown on the instrument cluster display. If the BSD is switched off, the indicator lamp will go out.

### **i** NOTE

The system has a memory function for the switch state and mode selection, so when the vehicle is restarted, the system will work in the state and mode before last shutdown.

### How it alerts the driver

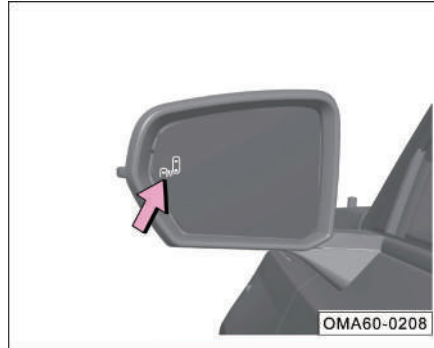

The BSD alerts the driver via the yellow indicator lamp  on the exterior rearview mirror, whose illuminance can be adjusted automatically according to the ambient light.

### **👁** CAUTION

When the vehicle has been started or the system has been switched on, the yellow indicator lamp  will come on for two seconds, indicating that the function is switched on normally.

### Working conditions

Under the following three conditions during driving (vehicle speed >15km/h):

- Another vehicle enters the blind spot from the rear or from one side.
- Another vehicle approaches quickly from the rear of the adjacent lane.
- Other vehicles enter the blind spot from the front and stay there longer than a certain period of time.

In any of the three situations above, the BSD issues an alarm and the indicator lamp on the corresponding exterior rearview mirror comes on, and if the turn signal lamp on the same side is turned on in this case, the indicator lamp will flash to alert you the risk of changing lane.

### **👁** CAUTION

When the vehicle overtakes another vehicle ahead at a very high speed, the alarm will not be activated for the vehicle in the blind spot as the time that the vehicle stays in the blind spot is too short.

## 5. Driving guide

### False alarm

When there is no vehicle in the blind spot, the system may issue a false alarm in case of the following conditions:

- The vehicle is near a road guardrail.
- The vehicle is near a highway concrete wall.
- The vehicle is in a building area.
- The vehicle is passing a sharp turn around a building.
- The vehicle is near shrubs and trees.

#### CAUTION

The false alarm, if triggered, just lasts for a short time and can be corrected automatically.

### Radar sensor



The BSD radar sensors are installed as shown above.

#### CAUTION

Make sure that the area around the rear bumper sensors is not covered by ice, snow or other objects.

If any sensor is interfered, the system performance will be degraded and the instrument cluster will display a prompt “BSD sensor is blocked” and issue an alarm. The system will automatically return to normal if any of the following conditions is met:

- A vehicle is detected on both sides of the vehicle.
- The vehicle is powered off and the engine is restarted.

If the sensor is still interfered when the engine has been restarted, the reminder will be given again and an alarm will be issued. If the message reading “Please check the side assist system” is displayed on the instrument cluster, it indicates that the system is faulty, please go to the GAC Motor authorized shop for inspection in time.



The BSD system may not work properly or even be inoperative under the following special conditions:

- The detected target is too small, such as a bicycle, an electric self-balancing scooter, etc.
- The target is stationary.
- The weather is too severe (such as rain, snow, etc.).
- The vehicle is running on a curved road, a ramp, etc.

### 5.4.11 Rear crossing traffic alert (RCTA)\*

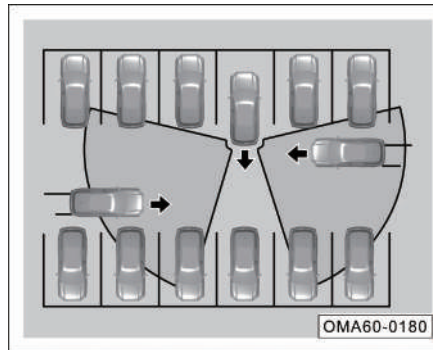

The rear crossing traffic alert (RCTA) system detects blind spots on both sides of the rear of the vehicle via the BSD sensor installed at the rear of vehicle. If it is detected that another vehicle is approaching quickly during reversing, the RCTA alerts the driver through the visual signal on the exterior rearview mirrors and the panoramic image.

#### WARNING

- The RCTA is only a driver assist system, and thus it cannot be substituted for the driver to observe the external traffic conditions or to make judgments.
- The driver shall correctly use the interior rearview mirror and both exterior rearview mirrors instead of completely relying on the BSD sensor to ensure safety.

## 5. Driving guide

### On and Off

With the ENGINE START/STOP button in "ON" position or after the engine is started, go to "Settings → Driving Assistance → Blind Spot Driving Assistance" in the AV system, and press the  soft key on the right side of "Rear Crossing Traffic Alert" to activate or deactivate this function.

When the engine is started or the system is turned on, the indicator lamp  on the rearview mirror will stay on for two seconds, indicating that the system is switched on normally.

### i NOTE

The system has a button state memory function, so that when the vehicle is restarted, the system will work in the state before last shutdown.

### How it alerts the driver

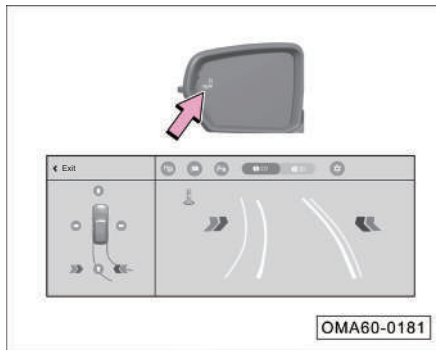

- Visual prompt: the RTCA alerts the driver via the yellow indicator lamp  on the exterior rearview mirror and the red flashing arrow on the incoming vehicle side in the panoramic image. The illuminance of indicator lamp can be automatically adjusted according to the ambient light.
- Audible alarm: there will be an audible alarm as a supplementary reminder at the same time.
- Active braking: When the braking mode is activated and the risk of a collision continues to increase, the system actively applies brakes. The driver can select the desired warning method in the AV system.

### i NOTE

Go to "Settings → Driving Assistance → Blind Spot Driving Assistance" in the AV system, and press the  soft key on the right side of "Rear Automatic Emergency Braking" to activate or deactivate the active braking alarm mode.

### Working conditions

The preconditions required for activating the function are as follows:

- The vehicle is reversing and the gearshift lever is in "R" position.
- The vehicle speed is lower than 10km/h.
- The function is enabled and has no fault.

When the radar detects that the vehicle is reversing and another vehicle is approaching to the vehicle on either side from the rear and may collide with the vehicle, the RCTA will alert the driver in the following way:

- On the side with risk of collision, the yellow indicator lamp  on the exterior rearview mirror flashes.

- In the panoramic image, a red light bar flashes at the rear of the vehicle on the side with risk of collision.
- When the driver selects the assist mode as the brake mode, the system will actively activate the brakes until the vehicle comes to a standstill.

### CAUTION

This function cannot penetrate through another vehicle or obstacle and detect objects behind it.

### CAUTION

The false alarm, if triggered, just lasts for a short time and can be corrected automatically.

#### False alarm

When there is no vehicle in the detection area, the system may issue a false alarm in case of the following conditions:

- The vehicle is near a road guardrail.
- The vehicle is near a highway concrete wall.
- The vehicle is in a building area.
- The vehicle is passing a sharp turn around a building.
- The vehicle is near shrubs and trees.
- The vehicle is too close to the vehicle behind during parking.
- The vehicle is in an indoor parking area.

### 5.4.12 Rear approach alert system\*

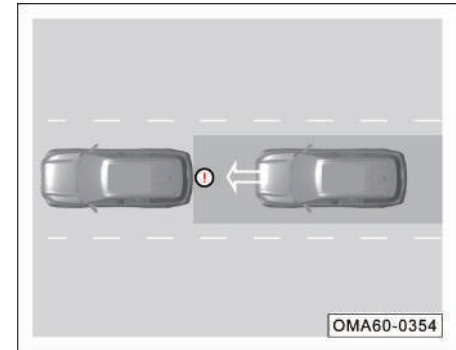

The rear approach alert function monitors the target directly behind the vehicle in real time through the BSD sensor installed at the rear of the vehicle. When the driver drives the vehicle normally on the road and there is a target rapidly approaching in this lane behind, the system will send out an alarm message and a rear-end collision warning signal to the vehicle behind.

## 5. Driving guide

---

### CAUTION

The rear approach alert function is only for assist and cannot replace the driver to monitor the external traffic conditions. The driver should always be alert to the surrounding environment.

### On and Off

With the ENGINE START/STOP button in "ON" position, go to "Settings → Driving Assistance → Blind Spot Driving Assistance" in the AV system, and press the  soft key on the right side of "Rear Approach Alert" to activate or deactivate this function.

### NOTE

The system has the button state memory function, so that when the vehicle is restarted, the system will work at the state before last shutdown.

### How it alerts the driver

The rear approach alert function automatically activates and quickly flashes the hazard warning lamps to alert the rapidly approaching vehicles behind.

### Working conditions

The preconditions required for activating the function are as follows:

- The vehicle is started and the gearshift lever is in a position other than R.
- The function is enabled and has no fault.

When the radar detects that there is a vehicle approaching at a high speed in this lane behind, the function will be activated to alert the driver in the vehicle behind to reduce the risk of rear-end collision.

### CAUTION

- This function cannot detect objects behind another vehicle or obstacle.
- When the vehicle behind is moving too fast, this function may not issue an alarm in time.
- This function does not trigger an alarm when the driver has turned on the hazard warning lamp switch.

### False alarm

When there is no vehicle in the detection area, the system may issue a false alarm in case of the following conditions:

- The vehicle is in a parking lot.
- The vehicle is on uneven roads.
- The vehicle is in a building area.
- The vehicle is near shrubs and trees.

### CAUTION

The false alarm, if triggered, just lasts for a short time and can be corrected automatically. oft damp cloth to avoid scratching it.

### 5.4.13 Door open warning (DOW)\*

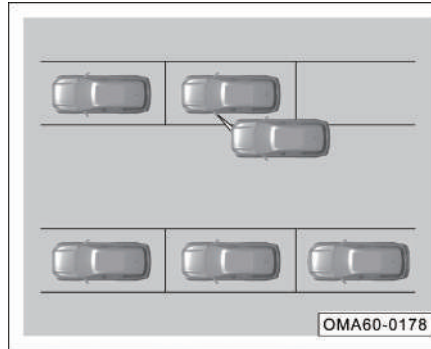

The door open warning (DOW) system uses the BSD sensor installed at the rear of the vehicle to detect the adjacent lane during parking, and when another vehicle is detected approaching quickly and will cause risk of collision if the door is opened, alerts the driver via the visible signal on the exterior rearview mirror and the audible alarm.

### WARNING

- The DOW is only a driver assist system, and thus it cannot be substituted for the driver to observe the external traffic conditions or to make judgments.
- The driver shall correctly use the interior rearview mirror and both exterior rearview mirrors instead of completely relying on the BSD sensor to ensure safety.

## 5. Driving guide

### On and Off

With the ENGINE START/STOP button in "ON" position or after the engine is started, go to "Settings → Driving Assistance → Blind Spot Driving Assistance" in the AV system, and press the  soft key on the right side of "Door Opening Warning" to activate or deactivate this function.

#### NOTE

The system has the button state memory function, so when the vehicle is restarted, the system will be in the state before last shutdown.

### How it alerts the driver

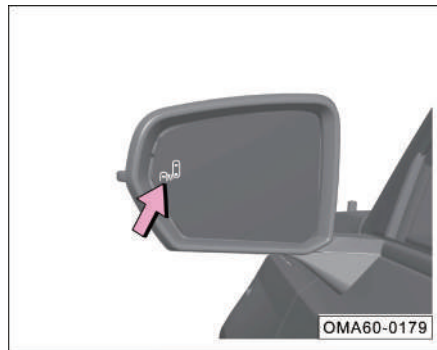



The door open warning system alerts the driver via the yellow indicator lamp  on the exterior rearview mirror. The indicator lamp can automatically adjust the brightness according to the external lighting conditions.

### Working conditions

The preconditions required for activating the function are as follows:

- The vehicle is parked.
- The ENGINE START/STOP button is in "ON" position, or switched from "ON" position to "ACC" or "OFF" position for not more than 3 minutes.
- The function is enabled and has no fault.

When the radar detects a vehicle behind in the adjacent lane and there is a risk of collision if the driver opens the door, the yellow warning lamp  on the exterior rearview mirror on the danger side will come on. If the driver continues to open the door, the warning lamp  will flash and an audible alarm will be issued.

#### CAUTION

This function cannot penetrate through another vehicle or obstacle and detect objects behind it.

### False alarm

When there is no vehicle in the detection area, the system may issue a false alarm in case of the following conditions:

- The vehicle is near a road guardrail.
- The vehicle is near a highway concrete wall.
- The vehicle is in a building area.
- The vehicle is passing a sharp turn around a building.
- The vehicle is near shrubs and trees.
- The vehicle is too close to the vehicle behind during parking.

### CAUTION

The false alarm, if triggered, just lasts for a short time and can be corrected automatically.

### 5.4.14 Emergency lane keep aid (LKA) system\*

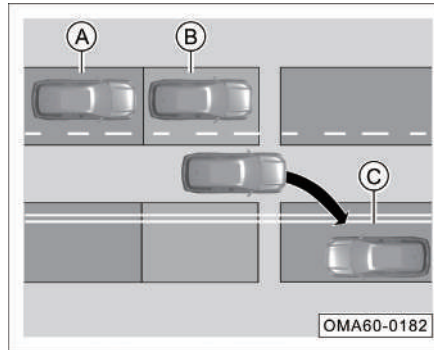

- A: Blind spot in the adjacent lane.
- B: Area behind the blind spot.
- C: incoming area in the adjacent lane.

The emergency lane keeping aid function monitors the adjacent lane area in front and behind the vehicle in real time through the rear BSD sensor, IFC and front IFC. When the vehicle deviates from the lane and there is a risk of collision with vehicles in the adjacent lane, the system will alert the driver and actively keep the vehicle in the lane to reduce the risk of collision.

### On and Off

With the ENGINE START/STOP button in "ON" position, go to "Settings → Driving Assistance → Lateral Driving Assistance" in the AV system, and press the  soft key on the right side of "Emergency Lane Keeping" to activate or deactivate this function.

### NOTE

- When the driver turns on the emergency lane keep assist function, the blind spot detection function is automatically turned on.
- The system has the button state memory function, so when the vehicle is restarted, the system will be in the state before last shutdown.

## 5. Driving guide

### How it alerts the driver

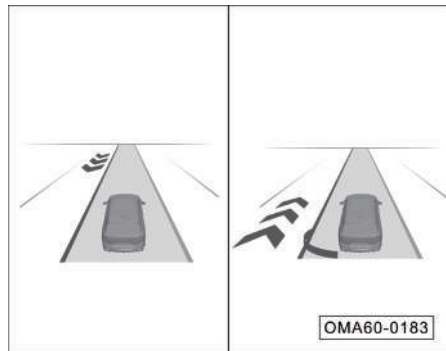

- Visual alarm: there will be a visual alarm on the instrument cluster, the lane marking on the dangerous side will turn red, and the dangerous target vehicle will turn red as a reminder. If the blind spot detection alarm conditions are met at this time, the exterior rearview mirror indicator lamp will come on.
- Steering assist: the system will actively control the steering wheel to keep the vehicle in its own lane, and the driver can feel the torque exerted by the system on the steering wheel.

### Working conditions

The preconditions required for activating the function are as follows:

- The vehicle is set in forward gear and the vehicle speed is greater than 65km/h.
- The blind spot detection system is turned on.
- The blind spot detection system and the lane departure warning system are not faulty.

When it is detected that the vehicle is at risk from changing lanes, the system actively controls the steering and issues a reminder on the instrument cluster.

### CAUTION

- Emergency lane keep assist is only an auxiliary function and cannot replace the driver to monitor traffic conditions. The driver should always be alert to the surrounding environment. This function cannot detect objects behind other vehicles or obstacles.
- The driver shall always hold the steering wheel to actively control the vehicle.

### CAUTION

- When the road environment cannot meet the operating conditions of the lane departure warning system, this function may not work properly. => See [page 184](#)
- When the forward radar does not work properly, this function also does not work.
- When the blind spot detection function does not work properly, this function may not work properly too.
- When the system detects that the steering wheel is out of the driver's hands for a long time, it issues a warning. In this case, don't panic or turn the steering wheel fiercely. and instead, please hold the steering wheel and drive the vehicle as usual.
- When ICA intervenes in the steering wheel for steering assist, the driver can still turn the steering wheel to control the vehicle. When the torque applied by the system is found improper, the driver can control the vehicle to travel according to his intention when required.



### False alarm

When there is no vehicle in the detection area, the system may issue a false alarm in case of the following conditions:

- Poor line of sight, such as snow, rain, fog or water spots.
- Dirty or foggy windshield, or obstruction in front of the windshield camera.
- Overtemperature around the camera due to direct sunlight.
- Glare due to direct sunlight, oncoming traffic, reflected light from road water-logging, etc.
- Sudden changes in outdoor brightness, such as entering/exiting tunnels.
- Headlamp not turned on at night or when the light illumination is low in tunnels.
- No lane marking, or difficulty in distinguishing the lane marking color from the road surface color.
- Unobvious, too thin, worn, blurred or dirt/snow-covered lane markings.
- Too wide or narrow lanes.
- Increase or decrease in lanes, or complicated routing of lane markings.
- More than two lane markings on the left and right sides of the vehicle.
- Marks or objects similar to lane markings on roads.
- Short-term change of marking, such as ramp or highway exit.
- Driving on steep slopes or curved roads.
- Close distance from the vehicle ahead or lane markings blocked by the vehicle ahead.
- Severe shaking of the vehicle.
- The vehicle passes by road guardrails, highway concrete walls, trees, shrubs, etc.
- The vehicle passes over speed bumps or potholes.
- The vehicle passes through dense buildings.
- The vehicle is running on a steep slope or curvy road.
- The forward radar and the left and right rear BSD radars are covered with dirt, rainwater or snow.

### CAUTION

The false alarm, if triggered, just lasts for a short time and can be corrected automatically.

Under the following conditions, the performance of the system may be affected while it intervenes in turning of steering wheel for corrective steering adjustment:

- vehicle overload.
- abnormal tire pressure.
- uneven road.
- strong crosswinds.
- Any part involved in vehicle control is modified or replaced with a non-genuine part.
- improper assembly of vehicle control-related parts.

## 5. Driving guide

### 5.4.15 Radar and camera sensor\*

#### Millimeter-wave (MMW) radar sensor

The MMW radar sensor is installed in the middle of the grille under the front bumper to monitor the traffic conditions and detect the front vehicles at a certain distance from own vehicle.

The radar sensor must be adjusted and calibrated under the following conditions:

- The fixing bracket of the MMW radar sensor is removed and refitted.
- The MMW radar sensor is removed and refitted.
- The toe or rear wheel camber is adjusted during the four-wheel alignment.
- The vehicle has a collision.

#### NOTE

- Special tools are required in adjustment and calibration of the MMW radar sensor. If the MMW radar sensor needs adjustment and calibration, please go to the GAC Motor authorized shop for relevant operation.
- When the MMW radar sensor has a failure or maladjustment, it may affect the normal operation of ACC \*, ICA \* and FCM \*.

#### **Special considerations on MMW radar sensor**

The MMW radar sensor is installed at the front of the vehicle, and no obstacle shall be present in its detection area. Do not install the obstacles such as the license plate frame when installing the front license plate. Otherwise, it will affect the detection performance of the MMW radar sensor, resulting in working failure of ACC \*, ICA \* and FCM \*.

#### CAUTION

- If the MMW radar sensor is dirty, blocked by the license plate frame, or covered by any foreign matters such as heavy rain, ice, snow, mud, the related functions of the radar sensor may not work and the instrument cluster will give disable/fault indication for these functions. To restore these functions to normal, clean the dirt and/or foreign matters.
- When strong reflection of the MMW radar is involved, such as in parking lots, the related functions of the radar sensor may be affected.
- Prevent the front and surrounding of the MMW radar from being covered by objects like sticker, driving assistance lamp, license plate frame, etc., otherwise the related functions of the radar sensor may be affected.
- It is recommended that the snow on the sensor is removed with a brush and the ice on the surface is removed with an insoluble de-icer spray.

### CAUTION

- Bodywork of the front end of vehicle may change the direction of the radar sensor and affect the related functions of the MMW radar (ACC \*/ ICA \*/ FCM \*). Therefore, please go to the GAC Motor authorized shop for service in time.
- If the MMW radar sensor is damaged or its direction changes, please deactivate its related functions (ACC \*/ ICA \*/ FCM \*), and go to the GAC Motor authorized shop for recalibration in time.
- The direction of the MMW radar sensor may be changed due to vibration, for example, when the part near the front bumper radar bumps against a curb/flower bed. Change of the direction of the sensor may affect the performance of the functions dependent on the radar or even cause abnormal deactivation of these functions.

### IFC

An IFC is installed on the upper part of the windshield glass to detect the surrounding environment, which can identify pedestrians up to 80m away from the vehicle when no obstacle is present (in case that the environmental factors such as lighting are ideal) with a height not less than 0.8m. The IFC sensor must be calibrated under the following conditions:

- The windshield or the camera bracket has been removed and replaced.
- The IFC sensor has been removed and replaced.

### NOTE

If the IFC fails, ACC \*, ICA \*, LDW \*, FCM \* and IHC \* will fail as well.

### NOTE

- Special tools are required to be used for calibration of the IFC. If the calibration of the IFC sensor is required, please go to the GAC Motor authorized shop for relevant operation.
- When the IFC sensor fails or is maladjusted or blocked, the normal operation of the functions such as ACC \*, FCM \*, LDW \*, ICA \* and IHC \* may be affected.

## 5. Driving guide

---

### CAUTION

- Poor lighting conditions, night, backlight, heavy rain, mist, ice, snow or sludge may affect the IFC, leading to interruption/performance degradation and even failure of FCM \*, ACC \*, ICA \*, AEB \*, LDW \* and IHC \*. In this case, the instrument cluster will display alarm messages relevant to intelligent driving assistance such as “The MRR is blocked”, “The sight of the IFC is blocked”, “Please check the LDW”, “Please check the ACC”, “Please check the FCM”.

### CAUTION

- Obstacles such as dust, sediment, mist, ice, snow, or sludge on the front windshield may block the sight of the IFC. If this occurs, the functions such as LDW \*, FCM \*, ACC \*, ICA \* and IHC \* will be disabled. In this case, please wipe the area around the camera on the front windshield or activate the A/C defrost/defog function. Thereafter, the functions will return to normal.

### CAUTION

- If the interference of IFC is cleared, the PDS will work normally again.
- Low light conditions at sunset or night may affect the functioning of PDS. Never block the sight around the IFC with stickers or opaque objects; otherwise, the PDS may not work properly.
- Before driving the vehicle, please check whether there is any obstacle in the area around the camera.
- Keep the sight of the camera on windshield glass free from any obstacle.

### 5.4.16 Tire pressure monitoring system (TPMS)

The TPMS monitors the pressure and temperature of the tire, and displays them on the instrument cluster. In case of tire anomalies such as low/high pressure, rapid air leakage and high temperature, the instrument cluster will display an alarm message accordingly.

If the vehicle has not been used for more than seven days or the battery has been disconnected, when the ENGINE START/STOP button is in "ON" position, the tire pressure and temperature will be displayed as "---" on the instrument cluster, and after the vehicle speed reaches above 25km/h for several minutes, the real-time tire pressure and temperature will be displayed on the instrument cluster.

#### Alarm description

- If the tire pressure is higher than 330Kpa, the TPMS indicator lamp will come on, and the alarm message about high tire pressure will be displayed on the instrument cluster; when the tire pressure is lower than 300kPa, the fault is eliminated and the tire pressure warning lamp goes out.
- If the tire pressure is lower than 75% of the normal set value, the indicator lamp of the TPM system comes on and the alarm message on the instrument display indicates that the tire pressure is low; when the tire pressure (cold tire pressure) rises to the normal set value, the fault is eliminated and the tire pressure warning lamp goes out.
- If the tire pressure keeps reducing by more than 30kPa/min, the TPMS indicator lamp comes on and the alarm message on the instrument display indicates that the tire has air leakage; the vehicle is powered on again, the fault is eliminated and the tire pressure warning lamp goes out.
- If the tire temperature is higher than 85°C, the tire pressure monitoring system indicator lamp will come on, and the text alarm will be displayed on the instrument cluster reading "Tire temperature is high"; when the tire temperature drops to 80°C, the fault is eliminated and the tire pressure warning lamp goes out.

#### CAUTION

After replacing the tire pressure sensor or rotating the tires, you do not need to go to the GAC Motor authorized shop for re-learning and calibration, provided that the tire pressure sensor is correctly installed for the model, because the TPMS can automatically complete the learning and calibration in the next few driving cycles.

#### NOTE

If the low tire pressure alarm does not disappear while you continue to drive as the tire pressure sensor is missing when a spare tire or a new tire has been replaced in another place. Please do not interpret that as abnormal tire pressure.

## 5. Driving guide

### 5.4.17 Cabin monitoring system\*

The cabin monitoring system monitors the facial features and behaviors of the driver and passengers in the vehicle through two cameras installed in left front of the driver (A-pillar) and on the interior rearview mirror cover. The following functions are achieved: distraction reminder, fatigue relief, smart ventilation, call-time sound reduction, sight-wakened screen, track skipping with gesture, and mood music. In the future, intelligent child attention, child care mode, getting off with peace of mind, remote viewing, journey record, etc. will be realized through OTA.

#### **i** NOTE

Some models are equipped with an intelligent cabin. All image information collected by the system will not be saved or uploaded except for the photos actively taken and saved by the people in the vehicle.

#### On and Off

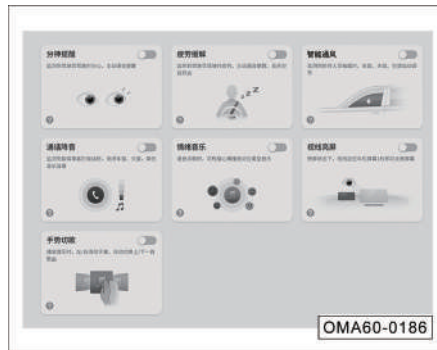

With the ENGINE START/STOP button in "ON" position, you can click the "Intelligent sensing" APP through the unit's application menu interface to enter this APP, and turn on or off the specific reminders of the corresponding monitoring function by clicking soft keys.

#### Reminder mode

##### 1. Fatigue relief

The cabin monitoring system can detect driver fatigue as: mild fatigue, moderate fatigue, and severe fatigue.

- When the cabin monitoring system is triggered by mild fatigue, a voice reminder will be issued to warn the driver to drive safely.
- When the cabin monitoring system is triggered by moderate fatigue, a voice reminder sounding "Dear, I noticed that you are very tired. May I play a song for you for refreshing?" will occur, and a pop-up box will appear. When you click OK or the pop-up box is not clicked till timeout, the refreshing music will be played; when you click Cancel, there will be no response.
- When the cabin monitoring system is triggered by severe fatigue, a voice reminder sounding "Dear, you have dozed off. For your driving safety, may I activate the wake-up mode for you?" will occur, and a pop-up box will appear. When you click OK or the pop-up box is not clicked after timeout, the refreshing music will be played, and at the same time, the A/C will be turned on in cooling mode, accompanied by red atmosphere lighting; when you click Cancel, there will be no response.

2. Distraction reminder
  - If the cabin monitoring system detects that the driver is distracted, it will remind the driver by voice sounding "Dear, please pay attention".
  - When the driver is on the phone without using the in-car Bluetooth, the voice sounding "For your safety, please use the in-car Bluetooth for calls" will occur and a pop-up box will appear (and disappear after 5s).

### **i** NOTE

The voice reminder will not repeat. After the first reminder, the alarm will not be activated again in 6 minutes.

3. Call-time sound reduction
  - When the front passenger is on the phone without using the in-car Bluetooth: A pop-up box reading "A comfortable call environment will be provided you" will appear (and disappear after 5s), the volume will be turned down, and the front passenger side anti-pinch window and the sunroof \* will be closed.
- When both the driver and front passenger are on the phone, and the in-car Bluetooth is in use: A pop-up box reading "As the AVN is in the Bluetooth call state, the media volume cannot be adjusted temporarily. For your convenience, the windows and sunroof \* will be closed now." will appear (and disappear after 5s), and all anti-pinch windows and sunroof \* will be closed.
- After the call ends, if the media volume is turned down for response before, the windows, sunroof \* and volume will be restored to the states before. If manual adjustment is performed, they will not be restored.
4. Sight-wakened screen
  - When the screen is in a black state and it is detected that the driver is looking at the screen for more than 1s, the screen will automatically turn on; if the sight leaves, the screen will automatically turn off.
5. Smart ventilation
  - When smoke is detected, a voice sounding "As it is detected that the front row occupant is smoking, ventilation will be automatically start" will occur and a pop-up box will appear. When you click OK or the pop-up box is not clicked till timeout, if it is not raining and the sunroof \* is closed, it will be set to the lifted state, the windows will be opened, the A/C

will be turned on and set to the fresh air mode; when you click Cancel, there will be no response. If it is raining, the sunroof \* and windows will not respond, while only the A/C will respond.

- After the smart ventilation is triggered, if no smoke is detected for a period of time, the windows, sunroof \*, and A/C will be restored to their original states.
6. Mood music

When the driver and passengers wake up the voice assistant and inform that music is needed with no specified song information, the cabin monitoring system analyzes whether the driver's current mood is natural, happy or unhappy according to the facial characteristics of the driver and passengers, then broadcasts the following voices respectively and plays the corresponding type of songs:

- For natural mode: "OK. Dear, the destination of language is music. Enjoy the music now".
- For happy mode: "OK. Dear, music is our simplest happiness. Let's swim in the ocean of music".
- For unhappy mode: "OK. Dear, music is the cure for all unhappiness. Enjoy it now".

## 5. Driving guide

---

### 7. Track skipping with gesture

When the music is on, within the visual range of the in-car monitoring camera, if the driver and passengers point their fingers to the front of the vehicle:

- Wave the palm from right to left, so the music will automatically skip to the previous track.
- Wave the palm from left to right, so the music will automatically skip to the next track.

#### Working conditions

- The face can be clearly detected by the system.
- The system completes the initialization.
- The power supply of the AV system is normal.
- For fatigue and distraction reminders, the vehicle speed should be greater than 30km/h.

#### i NOTE

- When the cabin monitoring system detects the face or behavior of the driver and passengers, it needs to operate within the effective range of the camera (that is, the camera can clearly identify full face features of the driver and passengers and the behavior above the waist).
- If such identification fails due to an invalid operating range, please adjust the position or posture.

#### False alarm

- Potential situations of false alarms: the vehicle is in a curve, the driver is turning the vehicle, entering or exiting a tunnel, or the camera is blocked.
- In some cases: direct sunlight on faces and seat or steering wheel adjustment will result in failure of face monitoring, etc., and the monitoring performance may be degraded.
- The system uses an infrared camera, which may be interfered with by some sunglasses, resulting in performance degradation.
- If the camera is interfered, the performance of the system will degrade.



### NOTE

The system will automatically return to normal if any of the following conditions is met:

- The camera re-identifies the driver's face information.
- The vehicle is powered off and the engine is restarted.

### CAUTION

After the function enters the working mode, due to the characteristics of the fatigue algorithm, the fatigue monitoring function needs 1 minute to complete the initialization and will not work in this process.

### WARNING

- **Even if the cabin monitoring system is provided, you are still responsible for concentrating on driving with care.**
- **If you feel tired, take regular breaks as needed and do not keep driving till the system warns you.**
- **Some special circumstances may cause the system to issue a warning even if you are not tired, for example, your eyes are closed for a certain period of time.**
- **The system cannot guarantee accurate identification of every driver, and some drivers' facial features may not be accurately captured.**
- **The system does not recognize the need for a break in all situations.**

### CAUTION

- Please abide by the national road traffic safety law and relevant implemented regulations for driving safety.
- Do not block the driver monitoring camera on the left front (A pillar) and the interior monitoring camera above the interior rearview mirror.
- Do not put trims on covers over the left front A-pillar and interior rearview mirror, neither install any other parts on these covers. Covers over the left front A pillar and interior rearview mirror contain sophisticated detection devices. The behavior described above may damage the devices or cause failure to correctly detect the real-time status of the driver.
- The cabin monitoring system function relies on a clear state image of the driver and passengers. Some cases such as strong direct sunlight, seat or steering wheel adjustment and rear occupants' faces blocked by front seats will result in incomplete monitoring data of the driver and passengers, and may cause performance degradation.

## 5. Driving guide

### CAUTION

- When the driver response function is turned on for detection, it will take some time to complete the initialization, and the monitoring function will not work in this process.
- Do not drive in fatigue state.
- For now, the intelligent cabin monitoring system only displays some functions. You can enter the APP store to update this APP in the future. New functions will be added, and the existing functions will be optimized and upgraded.
- If it is found that the camera is not working, please power the vehicle off and restart the engine. If the system still does not work normally, it is recommended that you go to the Go to the GAC Motor authorized shop for inspection in time.

### 5.4.18 Interior monitoring radar system \*

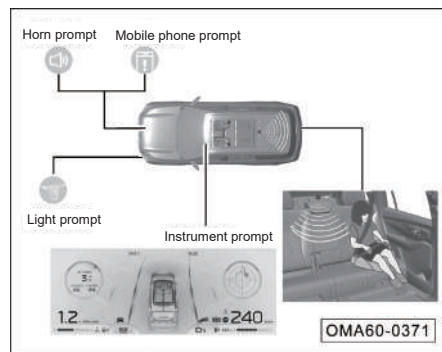

The interior monitoring radar system detects whether there is a life micro-motion signal in the rear seats through the MMW radar installed at the roof. When the vehicle is parked and locked, the radar will enter the working state within 10min. If vital signs are detected, the horn will sound, the position lamp will flash, and the driver's mobile phone will receive an alarm message, so that life will not be forgotten and the safety of occupants will be improved.

### On and Off

With the ENGINE START/STOP button in "ON" position, go to "Settings → ADiGO Intelligent Driving → ADiGO Active Safety → Life Presence Reminder" in the AV system to activate or deactivate this function. It is activated by default.

### WARNING

**Because the single radar system monitors the 2nd-row and 3rd-row seats at the same time, there is a certain risk of missing alarms. Therefore, it cannot replace the driver's judgment on the interior environment. Please check the actual situation of the rear occupants and then lock the vehicle.**

### 5.4.19 Head-up display (HUD)\*

#### HUD description

The head-up display or heads-up display is referred to as HUD for short. The HUD image is projected onto the front windshield through the HUD device in the instrument cluster.

The HUD image will automatically darken or brighten to compensate for changes in outside light. The brightness of the HUD image can be adjusted manually if necessary. Depending on the angle and position between the sunlight and the HUD, the HUD image will temporarily brighten, which is normal.

#### **i** NOTE

- Make sure the HUD image is in proper brightness and in comfortable field of view.
- Polarized sunglasses may make it harder to see the HUD image.

#### Interface display

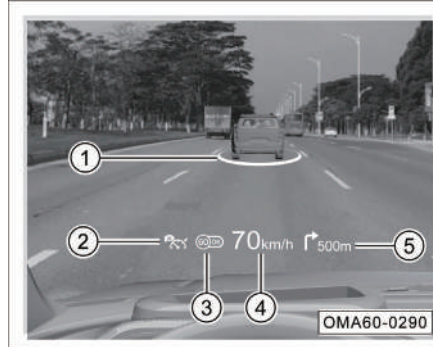

- ① Adaptive /integrated cruise control is working
- ② ADAS state
- ③ Speedlimit sign
- ④ Vehicle speed
- ⑤ Navigation information

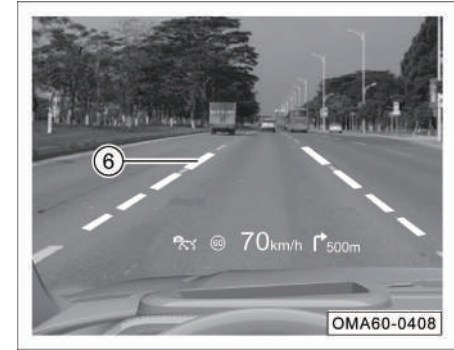

- ⑥ Blue line: the lane keeping assist function is triggered

## 5. Driving guide

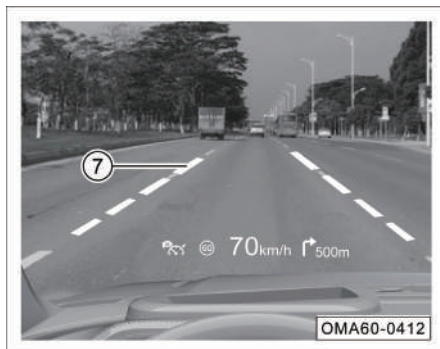

⑦ Red line: the lane departure warning function is triggered

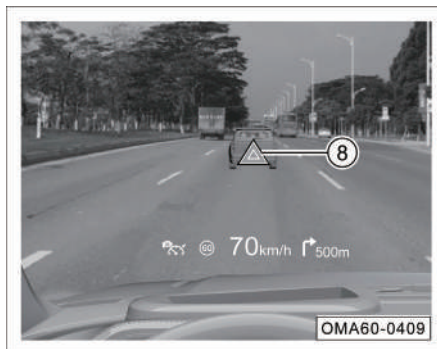

⑧ Forward collision warning level 1 is triggered

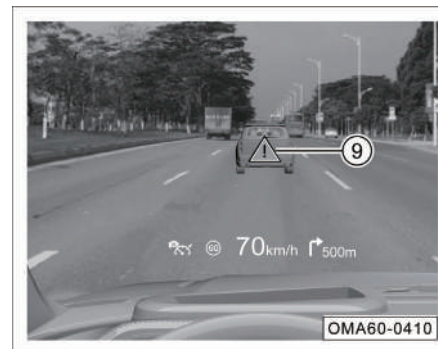

⑨ Forward collision warning level 2 is triggered

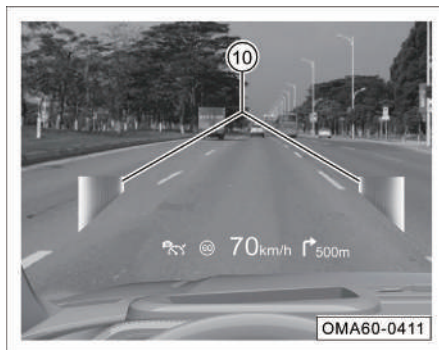

⑩ Red warning belt: blind spot detection function is triggered

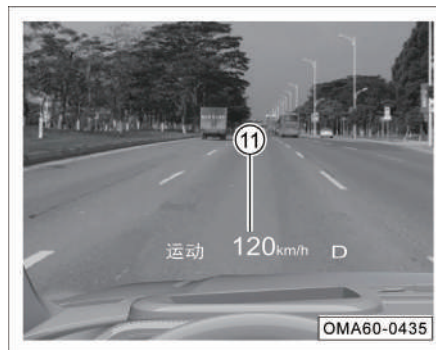



⑪ Gear position and driving mode

### **i** NOTE

The HUD interface is for reference only. Please refer to the actual vehicle.

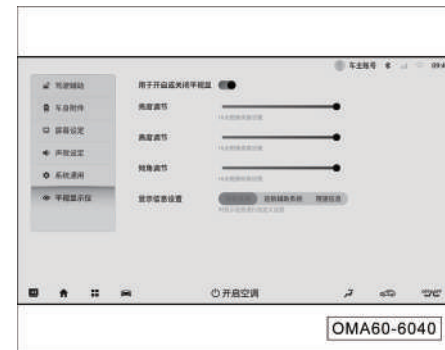
### HUD settings



Go to “Settings → HUD” in the AV system, press the  soft key on the right side of “HUD Switch” to activate or deactivate this function, and make corresponding settings.

### **i** NOTE

- HUD setting can be performed only when the vehicle is parked.
- During setting of the adjustment function, the corresponding interface is displayed on the HUD screen synchronously, and disappears 3 seconds if no operation is performed.

## 5. Driving guide

---

### HUD maintenance

- Clean the inner side of the front windshield to remove dirt or film that may reduce the brightness or clarity of the HUD image.
- Clean the top curved surface of the HUD with a soft cloth wet with glass cleaner, wipe it gently, and let it dry.

#### **i** NOTE

The front windshield of the vehicle equipped with HUD is specially made. If you need to replace the front windshield, you need to replace it with the corresponding type. Otherwise, there will be problems such as HUD image ghosting.

### 5.5 Parking assist system (PAS)

#### 5.5.1 Reversing parking aid (RPA) system

The RPA sends and receives the ultrasonic waves through RPA sensors and uses the ultrasonic waves sent and reflected by obstacles to measure the distance between the vehicle and obstacles.

##### On and Off

- When the ENGINE START/STOP button is in "ON" position, and the vehicle runs at a speed less than 10km/h with parking brake released and gearshift lever set to "R" position, the RPA will start working.
- When the forward speed is less than 10km/h, the front ultrasonic sensor starts to operate; when the forward speed is greater than 12km/h, the front ultrasonic sensor stop operating; when the forward speed decreases from 12km/h above to below 10km/h, the front ultrasonic sensor starts to operate again.
- When the vehicle speed is greater than 12km/h, the front and rear ultrasonic sensors will stop working; move the gearshift lever out of the "R" position, and apply the parking brake, so the ENGINE START/STOP button will exit the "ON" position and the reversing parking aid system is out of work.

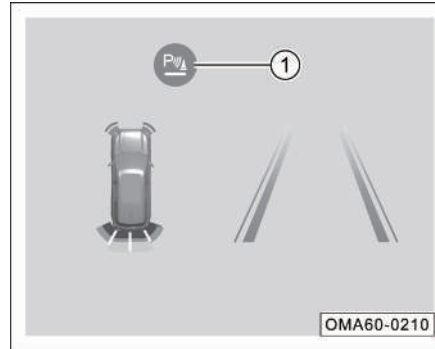

- When the RPA is activated during reversing, the audible alarm can be turned off and on manually by clicking the soft key ① P<sub>PA</sub>. The audible alarm of the RPA will be on by default when the engine is restarted.

#### **i** NOTE

It is recommended that the RPA audible alarm is activated during reversing.

##### Dynamic view\*



The dynamic view on the left of the display shows the distance between the front/rear of the vehicle and the obstacle. In the figure, the indication sectors of radar of the vehicle is red-orange-yellow-yellow from inner side to outer side. When an obstacle is getting closer and closer to the vehicle, the color sections will gradually reduce from the outermost.

Change of dynamic view is synchronized with that of the distance audible alarm.

## 5. Driving guide

Distance to detected obstacle						Audible alarm level
Front left sensor	Front right sensor	Rear left sensor	Rear right sensor	Rear left middle sensor	Rear right middle sensor	
No display & alarm	No display & alarm	No display & alarm	No display & alarm	150~90cm	150~90cm	No audible alarm
No display & alarm	No display & alarm	No display & alarm	No display & alarm	90 ~ 60 cm	90~60cm	Regular medium audible alarm
60~30cm	60~30cm	60~30cm	60~30cm	60~30cm	60~30cm	Regular rapid audible alarm
< 30cm	< 30cm	< 30cm	< 30cm	< 30cm	< 30cm	Continuous audible alarm

### Distance audible alarm

The audible alarm changes with reference to the distance between a detected obstacle and the front/rear bumper. In addition, the color of activated sector shown on the AV system display changes accordingly.



### Distribution of RPA sensors

Applicable to the model without automated parking:

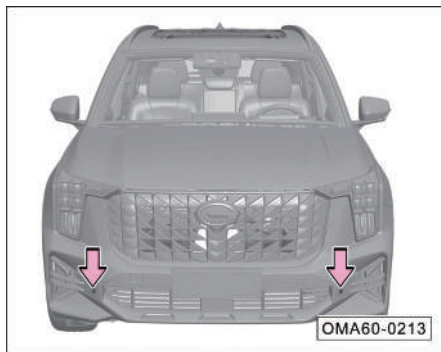

The front ultrasonic radar sensors are installed on the front bumper.



The rear ultrasonic radar sensors are installed on the rear bumper.

Applicable to the model with automated parking:

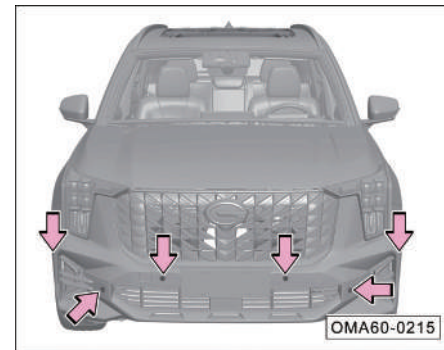

The front ultrasonic radar sensors are installed on the front bumper cover.

## 5. Driving guide

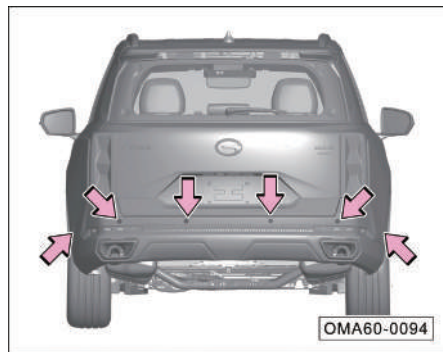

The rear ultrasonic radar sensors are installed on the rear bumper cover.

### CAUTION

- Always keep the surfaces of the RPA sensors clean and never cover a RPA sensor.
- Keep the RPA sensors on the bumpers clean and protect them from freezing to ensure the RPA sensors operate properly.
- Clean the RPA sensor surface with a piece of soft damp cloth to avoid scratching.

### WARNING

- **The RPA cannot take the place of the driver's observation of the surrounding environment. The driver shall focus on safe reversing and position adjustment according to the practical conditions.**
- **The RPA sensors have blind spots while they are detecting obstacles. During reversing, the driver shall observe the surrounding environment carefully to avoid scratches or collisions.**
- **When the vehicle is reversing at a narrow place or on an uphill slope, the RPA sensors may not detect railings, trees or slope surfaces, which is normal.**
- **When the reversing speed is high, the detection accuracy of the RPA sensor reduces. Thus the reversing speed had better not to exceed 10km/h. When the RPA sends the continuous audible alarms, it indicates that the vehicle is extremely close to the detected obstacle, and reversing shall be stopped immediately to prevent an accident.**

### WARNING

- When a high-pressure cleaner is used, clean the radars in snatches gently, with the nozzle at least 30cm away from the sensor.
- If water drops are on the surface of the RPA sensor on the bumper, the sensitivity of the sensor will reduce. Wiping off them can restore the sensitivity of the radar.
- The surface of some materials cannot reflect the signal from the RPA sensors, so that the RPA sensors cannot detect such materials or people wearing the clothing made of such materials.
- Noise sources outside the vehicle may interfere with the RPA sensors, preventing them from detecting any object.
- The RPA sensor is a precision component, which shall not be removed, refitted and repaired without authorization. Otherwise, GAC will not assume any responsibility for the damage arising therefrom.

### 5.5.2 Reverse image system \*

The reverse image system can provide video recorded at wide angle up to 130° and display a wide-range image behind the vehicle on the AV system display to allow the driver to know various complex road conditions behind the vehicle and improve the safety of reversing.

#### Activating and deactivating reverse image system

With ignition switch set in "ON", the reverse image system will automatically start working if the gearshift lever is moved to the "R" position. In this case, the AV system display will begin to show the image behind the vehicle and display the dynamic trajectory in the reverse image.

If the gearshift lever is move out of the "R" position, the reverse image system will automatically stop working and the AV system display will exit from the reverse image.

### WARNING

The reverse image system cannot take the place of the driver's observation to the surrounding environment. The driver shall be concentrated and reverse safely according to the actual conditions.

#### Dynamic trajectory

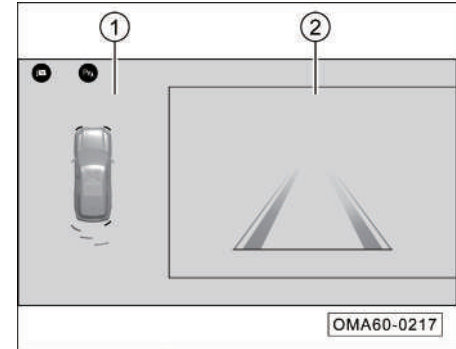

The display screen shows the track of the wheels and the driving route of the vehicle body:

- ① RPA sensor display area
- ② Reversing image display area

## 5. Driving guide

### CAUTION

The above-mentioned tracks are obtained by tests on the flat ground, and are only used as reference for visual distance judgment. In case of driving on a slope, the above tracks may have deviations.

### NOTE

- The vertical lines on both sides of the distance reference lines can be used as reference lines for judging the parking space you need during reversing.
- The distance reference lines can be adjusted from time to time as the steering wheel is turned.

### CCD



CCD is installed next to the license plate lamp.

### WARNING

- The CCD have blind spots, for example, it may not detect young children or small pets. Therefore, the driver is required to pay special attention to the young children or small pets around the vehicle during reversing.
- The CCD may not be able to recognize the vertical objects at high position, such as wall flange.

 CAUTION

- Always keep the CCD surface clean. Clean the surface of the CCD with a piece of soft damp cloth to avoid scratching.
- Do not use a high-pressure cleaner to clean the CCD for a long time, and if it to be used, please keep the nozzle at least 30 cm away from the CCD.
- Do not cover the CCD.

## 5. Driving guide





### 5.5.3 Around view monitor (AVM)\*

The AVM collects the left, right, front, rear images of the vehicle and integrate them into a 360° bird's-eye view of the surrounding environment, which is displayed on the AV system display to provide the driver with information on the surrounding environment of the vehicle and to reduce blind spots during driving. In addition, it can take the parameters such as steering wheel angle and vehicle dimensions into consideration to predict the vehicle's motion trajectory as well as superimpose the predicted track on the panoramic image to provide the driver with full information on the vehicle's direction of traveling, helping the driver to determine whether reversing is safe.

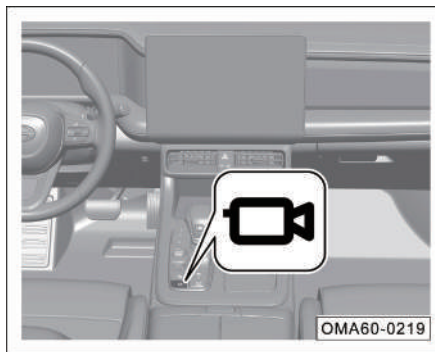
#### On and Off

1. With vehicle power switch in the "ON" position, the AVM can be activated/deactivated via the gearshift lever:
  - When the gearshift lever is moved to the "R" position, the AVM will be activated automatically.
  - When the gearshift lever is moved out of the "R" position and the driver do not carry out any relevant operation, the AVM will be deactivated automatically after 30s.



2. With vehicle power switch in the "ON" position, the AVM can be activated/deactivated by pressing the button 
  - When the button  is pressed, the button indicator lamp will come on and the AVM will be activated.
  - When the button  is pressed again, the button indicator lamp will go out and the AVM will be deactivated.
3. With vehicle power switch in the "ON" position, the AVM function can be activated by touching the icon  in the AV system menu bar to enter the AV system interface and then touching the "AVM" icon.

#### i NOTE

- When the AVM is activated, the AV system display will show the image around the vehicle and the reversing guidelines.
- If the forward speed is greater than 20km/h, the system will be automatically deactivated.
- When the gearshift lever is not in the "R" position and the AVM has been activated for more than 30s, the AVM will be automatically deactivated (at zero vehicle speed).
- If the AV system is not completely activated, the AVM cannot function properly.

### Interface description

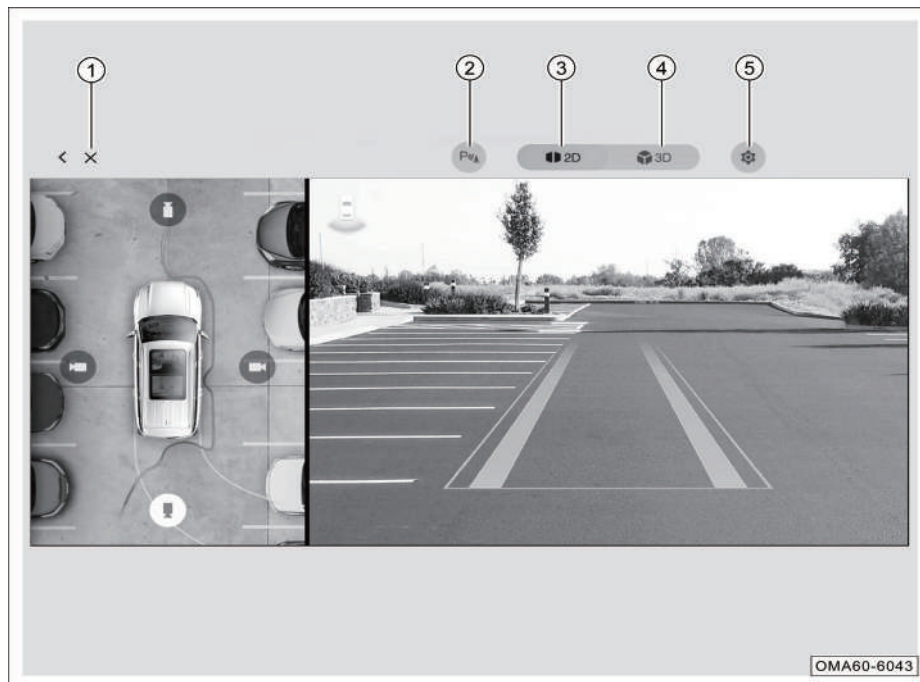

- ① Exit
- ② Radar audible alarm switch
- ③ 2D view soft button
- ④ 3D view soft button
- ⑤ Settings

## 5. Driving guide

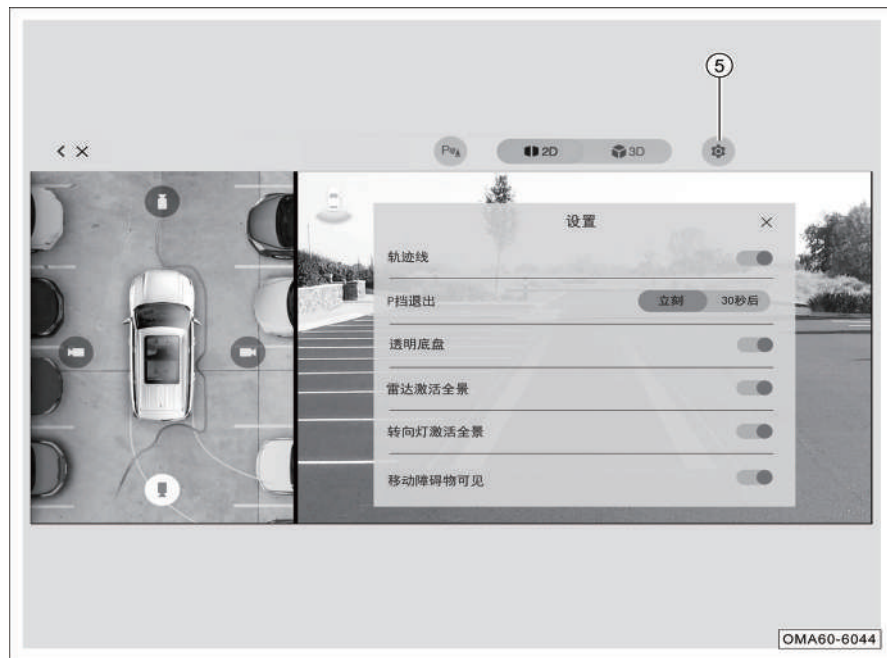

### AVM settings:

Press the Settings button (5) to enter the AVM settings interface, and the followings can be set:

- Trajectory: Activate or deactivate the lane trajectory in the panoramic view and AR view.
- Exit after gearshift lever in P position: When the gearshift lever is moved from R position to P position, you can choose to exit the interface immediately or delay 30s to exit the interface.
- Transparent Chassis: Activate or deactivate the transparent body function.
- Panoramic view after activation of radars: Activate or deactivate the radar activation function. After this function is activated, when the vehicle speed is  $\leq 20\text{km/h}$  and the radars detect an obstacle, an audible alarm will be issued and the panoramic view will be shown automatically.
- Panoramic view after activation of turn signal lamps: Turn on or off the left/right turn signal lamps to switch between the left/right views. After this function is activated, when the vehicle speed is  $\leq 20\text{km/h}$  and the left/right turn signal lamps are turned on, the panoramic view will be shown automatically, displaying the corresponding time. When the turn signal lamps are turned off, the panoramic view will disappear automatically.
- Visible moving obstacle (only for configuration with APA).



## 5. Driving guide

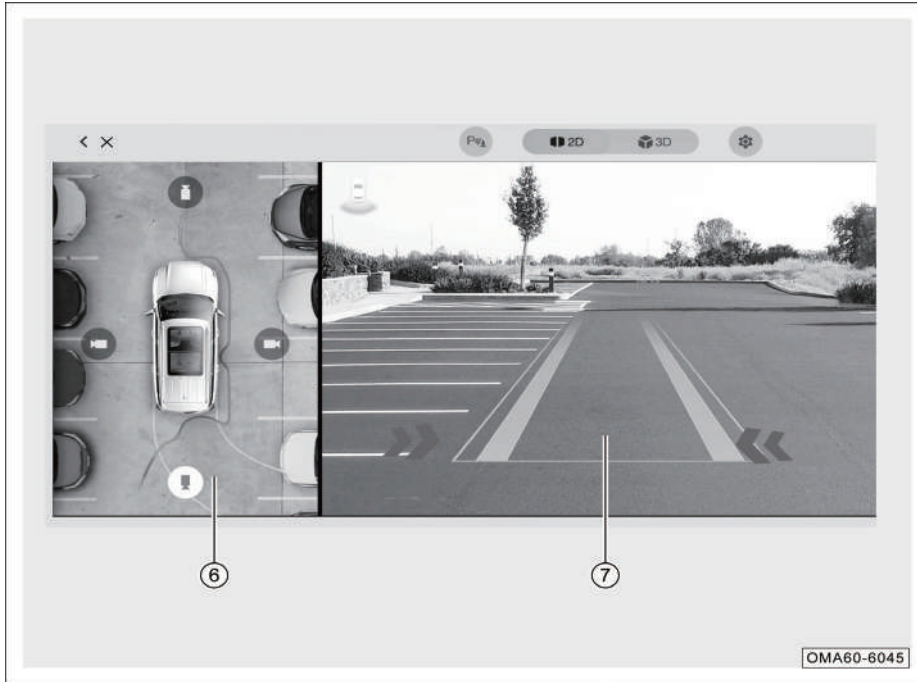

When the AVM starts working, the 2D view will be shown:

- ⑥ 2D view interface: 4 camera views, that is, front, rear, left and right views. The cameras can be selected to switch among the reversing images.
- ⑦ Trajectory.

### **i** NOTE

- The description of display interface is for reference only. In case of any discrepancy, the actual vehicle shall prevail.
- The 3D view interface can be shown by touching the  3D view button.
- When the gearshift lever is moved to “R” position, the rear view interface will be shown by default; when the gearshift lever is moved out of the “R” position, the front view interface will be shown by default.

## 5. Driving guide

### Layout of cameras

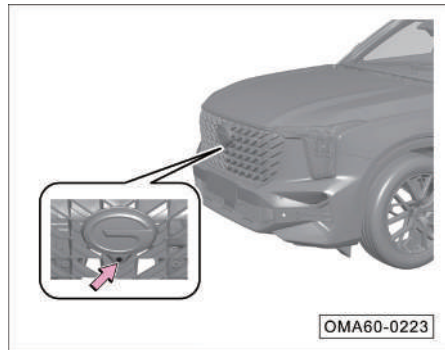

The front camera is installed under the front logo.

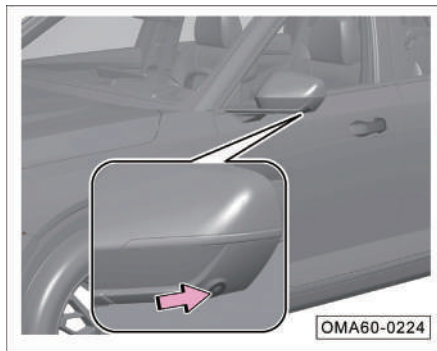

The left & right cameras are installed on the left & right exterior rearview mirrors.

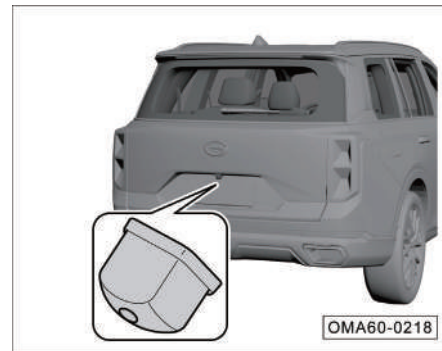

CCD is installed next to the license plate lamp.

### CAUTION

- Please keep the camera surface clean.
- Do not use a high-pressure cleaner to clean the camera for a long time, and be sure to keep the nozzle at least 30 cm away from the camera during cleaning.

### AVM DVR

The AVM is integrated with a data video recorder (DVR), and after a TF card is inserted, the real-time image, album and setting functions of DVR can be operated. The DVR collects and processes the video taken in the front, rear, left and right sides of the vehicle, and displays and plays the video on the AV system display; the recorded videos are stored in the TF card of the AVM ECU.

When the vehicle power switch is set to "ON" position, the AVM background will start video recording by default. After the TF card is installed and the loop recording switch is turned on in the Settings, the user can enter the DVR interface in the following two ways:

1. Enter the system menu interface by touching the icon  in the AV system menu bar, and then touch the "REC" icon to turn on the DVR function.

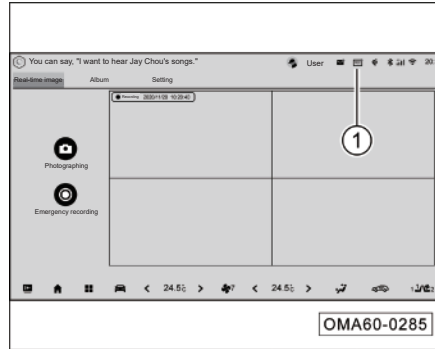

2. Touch the icon  ① in the status bar at the top right of the AV system interface to turn on the DVR function.

### NOTE

- The vehicle is not installed with a TF card upon delivery. Users need to buy a TF card before use. The TF card shall meet the CLASS10 standard and has a capacity above 16G.
- Do not pull out the TF card directly during video recording, and instead, operate after the power supply is cut off.

### Installation location of DVR TF card

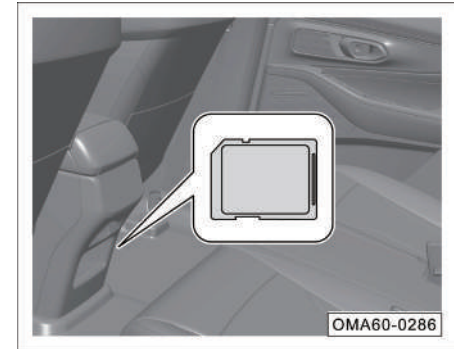

- The TF card installation location is behind the bottom of the front passengers' seat, and it can be accessed by unfastening the hook & loop fastener on the carpet.

## 5. Driving guide

### Interface description

#### Real-time image function area

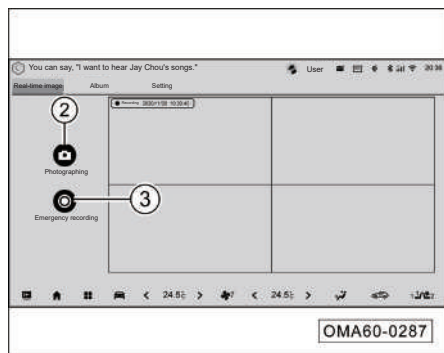

- The current panoramic image of the vehicle is displayed in real time.
- Touch the “Photographing” button ② to take a photo record of the current real-time image and save it in “Album→Photo”.
- Touch the “Emergency recording” button ③ to record a video of 15s automatically and save it in “Album→Locked Video”.

#### Album function area

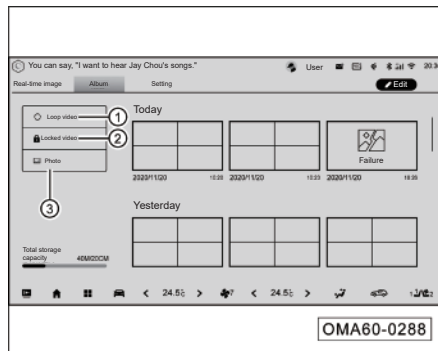

- “Loop video” ① is a video recorded and saved automatically, which can be selected for playback and other operations.
- “Locked video” ② is a video recorded and saved in emergency, which can be selected for playback.
- “Photo” ③ is an image saved after photographing, which can be deleted in the list.

#### Settings function area

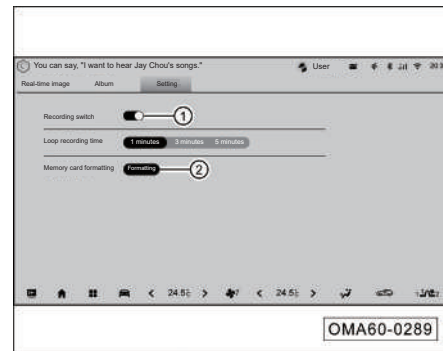

- Recording switch: After the soft button ① is touched, the system will automatically record and save in a loop.
- Loop recording time: This can be set manually.
- Memory card formatting: Touch the “Formatting” soft button ② for formatting.

### 5.5.4 APA \*

The APA automatically searches for parking bays on the left/right side of the vehicle through ultrasonic sensors and AVM cameras. When a suitable parking bay is searched, the driver can park according to the on-screen prompts, touch to select a parking bay and touch the parking button, and then the automatic parking mode can be activated.

In the automatic parking mode, the system can automatically plan and calculate the parking trajectory, and at the same time control the steering, vehicle speed, gear position, etc. of the vehicle to drive it into the parking bay. And the driver can release the steering wheel, brake pedal and accelerator pedal. Then the automatic parking in and out can be completed without need of any operation.

#### WARNING

- **Only the front and rear of the vehicle are equipped with radars. The sides of the vehicle are detection blind spots. If an obstacle enters the side of the vehicle, the APA cannot detect it, so the driver needs to actively observe it, and if there is a danger of collision, the driver needs to brake the vehicle in time.**
- **During parking, the driver should always pay attention to the surrounding environment of the vehicle and be ready to brake the vehicle at any time to avoid the APA not being able to recognize some obstacles such as columns, stones, sharp and thin objects, strip/flake-like objects, low objects, suspended objects, etc. which may affect the parking safety.**
- **Please find a legal, suitable and safe parking bay while using the system. The APA may be not always able to detect the objects on the parking bay. Therefore, be sure to visually inspect that the parking bay is suitable and safe.**



#### WARNING

- **Although the APA can provide assistance to the driver during parking, it cannot substitute for the driver, so the driver shall be vigilant during such automated parking!**
- **The APA is only a driver assist system, and thus the driver shall still take full responsibility for the vehicle safety.**
- **During parking, the driver shall observe the surrounding environment to avoid the driving safety from being affected by obstacles out of the detection range of the APA.**

## 5. Driving guide

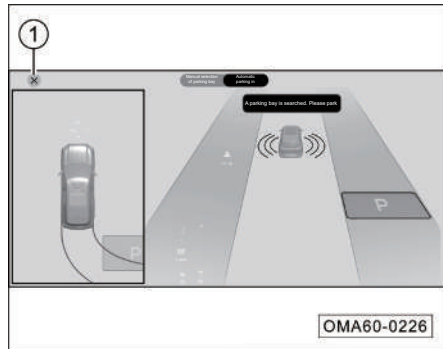
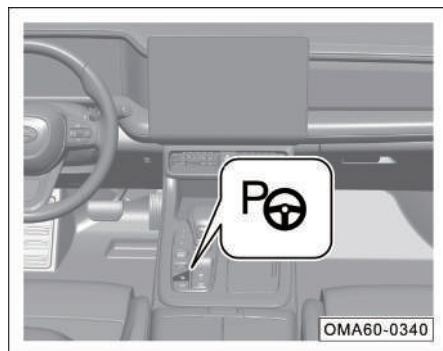
### Activation/deactivation/pause/interruption of APA



1. Activation
  - APA button: After the vehicle is started, press the APA button  to activate the APA.
  - Voice wake-up: Activate the APA by saying "Turn on APA", "Activate APA" or "Start APA".
2. Close
  - APA button: Press the APA button  again to deactivate the APA.
  - Exit button: Touch the "x"  ① in the upper left corner to deactivate the APA.
3. Pause
  - After the APA is activated, the driver can press the APA button, or depress the brake pedal, or opening a non-driver's door to pause the APA.

4. Interruption
  - After the APA is activated, the driver can touch the exit button, or turn the steering wheel, or depress the accelerator pedal, or operate the gearshift lever, or press the "P" position button, or unfasten the seat belt, or open the driver's door to interrupt the APA.

### Limitations

APA may involve safety risk and fail to operate normally under the following conditions:

- Narrow parking bays.
- Existence of the following objects in the parking bay: objects that cannot reflect the radar signal well, and objects that are not within the detection range of the ultrasonic sensor, such as columns, stones, sharp and thin objects, strip/flake-like objects, suspended objects, ground locks and other low objects, etc.
- Large road slopes.
- Poor visibility (due to night, heavy rain, snow, fog, etc.).
- Curb made of other materials than stone, or low curb out of the detection range.

- One or more ultrasonic sensors or AVM cameras contaminated or blocked by obstacles (such as mud, ice and snow).
- Bad weather (such as heavy rain, snow, fog, incredibly high or low temperature) which cause interference with the operation of the ultrasonic sensors or cameras.
- Sensors affected by other electrical equipment or devices which can generate ultrasonic waves.
- Too high or low tire pressure.
- Failure to recognize the parking bay due to unclear parking bay lines or blurred contrast with the ground.
- Failure to recognize the parking bay due to too narrow vehicle passage.
- Wrong recognition due to a vehicle in a relatively far position in the parking bay.
- During manual selection of parking bay, the user needs to ensure that the selected parking bays are legal, suitable and safe. When there is an obstacle in the selected parking bay, the APA may not be able to recognize it, so the user needs to observe it at all times, and if there is a risk, the user needs to brake the vehicle in time.

### i NOTE

- When the APA starts working, do not touch the steering wheel, or the APA will be deactivated.
- When the APA is activated, please follow the prompts on the multimedia display;
- Please drive at a low speed while searching for an available parking bay, because the APA will not work well when the vehicle speed exceeds 20km/h.
- Keep the vehicle body 0.5~1.5m away from the parking bays while the APA is searching for available parking bays.
- When searching for available parking bays, drive straight as far as possible, do not turn the steering wheel, and keep the heading angle between the vehicle body and the parking bay at  $\pm 6^\circ$ .
- For the ultrasonic detection, the effective length of standard horizontal parking bay is 6.3m, and the effective width of standard vertical parking bay is 3.2m.

### i NOTE

- The dimensions of the standard horizontal and vertical parking bays detected by the cameras are 6x2.5m, the dimensions of the standard angled parking bay are 7x2.5m, and the angle of the angled parking bay is  $45^\circ/60^\circ$ .
- The APA cannot always search a parking bay or can park the vehicle successfully. If no parking bay is searched or the parking is not successful, the APA can be re-activated for a second try.
- When the vehicle is approaching the target parking bay, the APA may pause for a short time, which is normal.
- The vehicle shall maintain standard tire pressures.

## 5. Driving guide

### i NOTE

Solutions in case of fault or interruption:

- After the vehicle is faulty or the function is interrupted, the APA can be re-activated by pressing the APA button under normal circumstances.
- In some cases, the vehicle must be shut down and restarted. If the APA fails to be re-activated after the vehicle is restarted and others systems cool down, please go to the GAC Motor authorized shop for inspection.

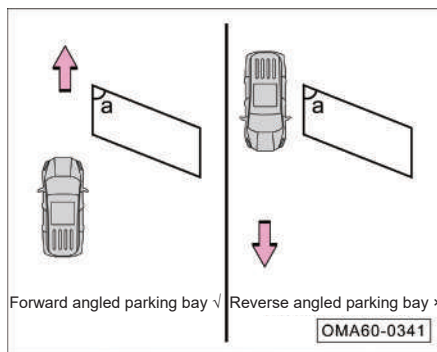
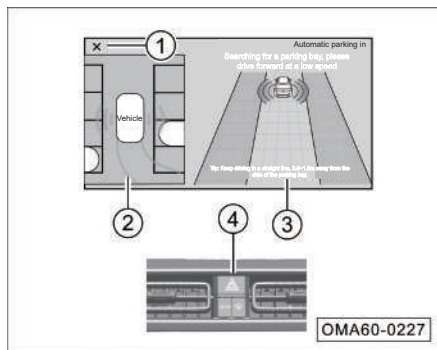

### i NOTE

- In the process of automatically searching for parking bays, ② and ③ areas will display the parking bays at the same time; ② area is subject to the image view, and there may be situations where the parking bay cannot be fully displayed, and in this case, the parking bay can be selected in ③ area.
- When the vehicle is parked in the parking bay, the vehicle will automatically turn on the hazard warning lamp to increase the parking safety; on the premise of ensuring the surrounding safety, this lamp can be turned off by operating the button ④.
- For an angled parking bay, the APA can only search it in the forward direction, not in the reverse direction. The forward angle (a) is 45°/60°.
- The automatic parking out is only applicable to horizontal parking bays, not applicable to vertical and angled parking bays.



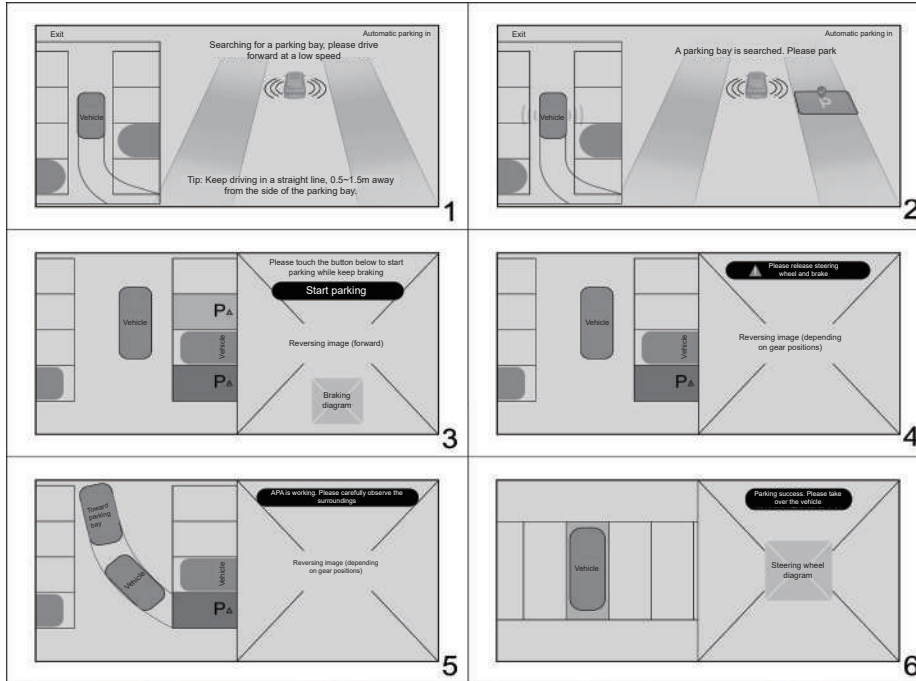

### Operation instruction

Take the automatic parking in as an example:

1. After the vehicle is started, press **PA** on the console. Then the APA enters the interface for searching the parking bays.
2. There is a prompt indicating "A parking bay is searched. Please park".
3. After the vehicle is parked, the "Start parking" button appears, and please keep braking.
4. After the "Start parking" button is pressed, there is a prompt indicating "Please release steering wheel and brake". At this time, it means that the vehicle is in the APA mode now, and please wait for the automatic parking success or manually deactivate the APA.
5. There is a prompt indicating "APA is working. Please carefully observe the surroundings".
6. Automatic parking success.

## 5. Driving guide

### 5.6 Electric power steering (EPS)

The EPS is a power steering system which directly uses the motor for providing torque. It is mainly composed of a torque sensor, a motor, a retarding mechanism and an electric power steering control unit (ECU).

The EPS ECU controls the torque provided by the EPS motor in real time by detecting the torque applied by the driver, the vehicle speed, the engine speed and other status signals of the vehicle to augment the steering effort in the best way so as to ensure the easiness of steering at a low speed and the stability of steering at a high speed, and to improve the driving comfort and vehicle safety.

#### CAUTION

After the four-wheel alignment of the vehicle, the midpoint of the steering angle sensor will be affected, so it is necessary to recalibrate the midpoint of the EPS torque and angle sensor (TAS). The difference between the left and right limit angles of the steering wheel is within 20°.

#### EPS indicator lamp

With vehicle power switch in “ON” position, the indicator lamp  lights up for a few seconds and then goes out after the system completes the self-test, indicating that the EPS works normally.

If the indicator lamp  does not go out after the engine is started or comes on during driving, it indicates that the EPS is faulty, and in the meanwhile, an alarm message indicating “Please check EPS” will be displayed on the instrument cluster display. In this case, it is required to park the vehicle in a safe place, and shut down and restart the engine. If the indicator lamp does not go out or comes on again while driving, stop driving, and contact the GAC Motor authorized shop for inspection.

#### Steering mode

There are three steering modes: Light, Comfort and Sport modes, where the hand force of the driver turning the steering wheel in Light mode will be small, in Comfort mode will be moderate, and in Sport mode will be large. The system is set to the Comfort mode by default. There are two ways to select the steering mode: ① On the AV system interface, select “Drive mode→Current mode setting→Steering mode”; ② If the drive mode is switched, the system can automatically set the steering mode (see “Drive mode”)

#### CAUTION

Please select the steering mode when the vehicle keeping still and the steering wheel is released.

### 5.7 Off-road modes \*

#### Drive mode switch

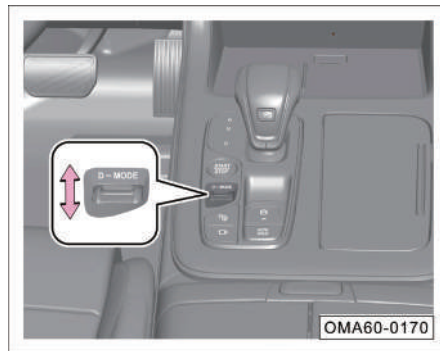

By the use of “D-mode” switch, the following off-road modes can be selected: snow mode, mud mode, and sand mode. The mode selection is at the same level as the economy mode, comfort mode, and sport mode.

When the off-road modes are selected, the corresponding mode information will be displayed on the instrument cluster and the AV system interface, and there will be a prompt indicating “XXX mode is not suitable for flat roads” for 10s on the instrument cluster.

#### Snow mode

- This mode is only applicable on off-road terrain or roads with deep snow.
- Avoid using this mode on roads with shallow snow, as it will occasionally make it difficult for the driver to control the vehicle.
- If the driver wants to drive on roads with shallow snow, please use dynamic drive mode and try not to use snow mode.

#### Mud mode

- This mode is only applicable on off-road muddy terrain. It is forbidden to use this mode on paved roads, as it will cause transmission failure.
- On slightly muddy roads, please use comfort mode or economy mode instead of mud mode.
- The mud mode is different from the snow mode. When the driver turns the steering wheel and depresses the accelerator pedal on non-muddy terrain, it is more difficult to control the vehicle than in the snow mode.

#### Sand mode

- This mode is only applicable on off-road terrain. It is forbidden to use this mode on paved roads, as it will cause transmission failure.
- The sand mode is the strongest off-road performance among the three off-road modes. It not only provides superior driving performance in deep sand, but also on off-road slopes.
- On muddy roads, please use mud mode instead of sand mode.

#### How to deal with “4WD system overheating” warning

- If the vehicle overheats in the economy/comfort/sport/snow/mud mode, just wait a few minutes for the warning to disappear and then the 4WD function will be recovered. If the warning appears again after a while, alternatively change to a relatively flat route, and if not feasible, wait 20 minutes for the transmission to cool down.
- If overheating occurs on off-road sand roads and the driver is not in trouble, just wait for the overheating to disappear.

## 5. Driving guide

---

### WARNING

Once there is a warning, please release the accelerator pedal immediately, otherwise the front wheels will be stuck and you can only wait for rescue.

### NOTE

Please select the appropriate off-road mode according to the actual terrain. Do not select the off-road mode on flat roads, otherwise the following situations will occur:

- When turning, you will feel jitter and a strong sense of resistance, which will increase fuel consumption and tire wear.
- Due to the improvement of off-road performance in off-road modes, the calibration parameters of each system are more radical. On flat roads, you need to drive the vehicle carefully to avoid losing control of the vehicle due to violent driving.

## 5.8 Driving skills

### 5.8.1 Pre-driving safety inspection

#### Routine inspection

- Check the tire for high/low pressure, cuts, bulges, damage or excessive wear.
- Check whether the wheel studs are missing or loose.
- Check whether the headlamp, brake lamp, tail lamp, turn signal lamp and other lamps work properly; check the lighting direction of the headlamp.
- Check that the seat belt is not worn or damaged; check that the seat belt is fastened securely after fastening the seat belt.
- Check that the free travel of the pedal is sufficient.
- Check whether the levels of coolant, engine oil, brake fluid and windshield washer fluid are normal.
- Check the battery terminals for corrosion or looseness, and check the battery case for cracks or deformation caused by expansion.
- Check for leakage of fuel, engine oil, water or other fluids under the vehicle, and pay attention that water drip found after A/C operation is normal.

#### Inspections after starting/during driving

- Check whether the instrument cluster works properly; check whether any indicator lamp comes on or any alarm message is shown, etc.
- Check whether all controls (such as the lamplight combination, wiper combination and defrost switches) work properly.
- Check that the vehicle does not deviates to one side during braking on a road without safety risks.
- Check for other anomalies, such as part looseness, leakage and unusual noise.

### 5.8.2 Driving during running-in period

In order to prolong the service life of the vehicle, the vehicle shall be subject to running-in of certain mileage before it is brought into use. Please comply with the following rules in the running-in period:

- The mileage in the running-in period shall be 1500km.
- Choose roads in good condition and drive it at reduced load and limited speed.
- Do not start the engine with full throttle or drive with harsh acceleration.
- Avoid emergency braking in first 300 km.
- Strictly follow the operating procedures and make sure that the engine has reached normal operating temperature. Do not change the oil before regular maintenance.
- Carry out daily maintenance of the vehicle carefully; check and tighten the external bolts and nuts frequently; check the sound and temperature changes of the assemblies generated by operation and adjust them timely.

#### Engine running-in

The mileage in the running-in period of a new engine shall be 1500km. Do not perform the following operations within the first 1000km of driving:

- Keep the vehicle speed no more than 3/4 of the maximum allowable speed.
- Do not drive the vehicle with full throttle.
- Avoid running the engine at high speed.
- Do not tow any trailer.

Within 1000km-1500km, it is allowed to increase the engine & vehicle speeds gradually to the maximum allowable range.

The internal frictional resistance of the engine at the beginning of running-in is much greater than that after running-in, and all the moving parts of the engine can have the best fitting after running-in.

After fully running in, both the service life and the fuel efficiency of the engine can be improved.

#### Running-in of tire and brake lining

Within the first 500km of driving, drive the vehicle at a moderate speed to get the new tires run in fully.

Within the first 200km-300km of driving, the brake linings have not reach the optimal friction condition, so please drive at a low speed and avoid emergency braking as much as possible.

#### WARNING

- **A new tire and brake lining will not have the best adhesion and friction characteristics without running-in. Therefore, drive the vehicle cautiously within the first 500km to get the tires fully run in to prevent accidents.**
- **Newly replaced brake lining shall be run in according to the above requirements as well.**
- **During driving, keep an appropriate distance from other vehicles to prevent emergency braking, as the new tires and brake linings have not been fully run in at this time and if an emergency braking is applied, a traffic accident is likely to occur.**

## 5. Driving guide



### WARNING

- If a brake is wet or icy or the vehicle travels on a salted road, the braking effect will be reduced.
- When the vehicle is running downhill, the brake works under a high load so the brake is very easy to overheat. It is recommended to downshift and reduce the vehicle speed before driving downhill so as to make full use of the braking effect of the engine to reduce the load on the brake.
- Apply the brake according to road and traffic conditions; do not depress the brake pedal when unnecessary, otherwise the brake will overheat due to friction, resulting in longer braking distance and excessive brake wear.
- Do not coast with engine shut down, because, when the engine is off, the brake booster cannot work and the braking distance will increase greatly, and an accident is likely to occur.

### 5.8.3 Driving essentials

#### Precautions under various road conditions:

- When the vehicle is driving on a road with crosswinds and gusts, please decelerate in advance and control the speed and steering wheel.
- Avoid driving on sharp-edged objects or other road obstacles, otherwise it may cause serious damage such as tire burst.
- Reduce the speed and drive at a low speed while driving on a bumpy or uneven road; otherwise the chassis may be scratched, which result in vehicle damage.
- When driving the vehicle downhill, decelerate in advance; avoid emergency braking, otherwise the brake system will overheat or be worn prematurely.
- When driving the vehicle on a slippery road, be careful during accelerating or braking; avoid sudden acceleration or emergency braking, otherwise it is likely to cause wheel slip.
- When the vehicle is running on an icy or snowy road, drive at a low and constant speed; avoid sudden acceleration or emergency braking and install tire chains for the wheels when necessary.

#### Precautions when driving over a water-logged road section

1. Before driving over a water-logged road section, check the depth of water, which shall not be higher than the lower edge of the vehicle body.
2. Before driving through water, switch off the A/C before starting, decelerate and then gently depress the accelerator pedal without release to drive over the water-logged road section at a stable and low speed.
3. Do not stop the vehicle, reverse or shut down the engine in water.
4. After successfully driving through the water-logged road section, gently depress the brake pedal for several times to evaporate the moisture on the brake discs so as to restore the braking performance as soon as possible.

### **i** NOTE

The brake linings and brake discs are soaked in water while the vehicle is washed or driven over a road with deep water logging, and the braking effect will be greatly reduced; the braking distance will be longer than usual and the vehicle may be deviated to one side, and the parking brake cannot hold the vehicle still. In this case, it is recommended to drive the vehicle at a low speed and constantly depress the brake pedal slightly to remove residual moisture in the brake to recover the braking effect to the normal level. And then, normal driving can be resumed.

### **Driving essentials in winter**

1. Check if the coolant is in good condition and if it has good anti-freeze effect as follows:
  - Fill the cooling system with the coolant of the same type as the original one according to the ambient temperature.
  - Adding unsuitable coolant may cause damage to the engine.
2. Check the battery and cables as follows:
  - A low temperature in chilly days will reduce the capacity of battery, and therefore, fully charge the battery for start-up in winter.
3. Prevent the door lock from being frozen by ice and snow as follows:
  - Spray some de-icer spray or glycerin into the door lock hole to prevent the door lock from being frozen.
4. Use washer fluids containing antifreeze:
  - These products are available at GAC Motor authorized shop.
  - The mix ratio of water to antifreeze shall comply with the manufacturer's instructions.
5. Avoid accumulated ice and snow beneath the mudguard:
  - Accumulated ice and snow beneath the mudguard may result in difficult steering. Stop the vehicle regularly to check for accumulated ice or snow beneath the mudguard while driving the vehicle in severe cold winter.
6. It is recommended to bring some necessary emergency items according to the road conditions, such as:
  - Tire chains, a window scraper, a bag of sand or salt, a flashing light, a plough staff, connecting cables, etc., which are recommended to be placed in the vehicle.
7. In cold winter (especially in northern China), avoid starting the engine frequently and shutting down the engine immediately after a short-time start. If the engine is often in an alternating heat & cold cycle, the condensed water is likely to form in the engine, and when the condensed water adheres to the engine oil, it may give an illusion of water-in-oil emulsion, and after the engine is restarted and warmed up, this illusion will be shattered; in addition, please change the oil regularly as required in the Warranty Manual.

## 5. Driving guide

---

### 5.8.4 Efficient use of vehicle

- Before driving, make sure that the parking brake is completely released and the parking brake indicator lamp is off.
  - Maintain sufficient tire pressure, as a too low tire pressure can cause premature tire wear and higher fuel consumption.
  - Ensure that the wheel alignment is accurate. Otherwise it will cause premature tire wear, increased engine load and higher fuel consumption.
  - Do not overload the vehicle, and unload unnecessary items from the vehicle, as excessive load will increase the engine load and the fuel consumption thereafter.
  - Accelerate the vehicle slowly and smoothly to avoid rapid acceleration.
  - Avoid roads with traffic jams as much as possible, as driving in traffic jam will increase the fuel consumption.
  - Follow the instructions of traffic lights or maintain a safe distance with other vehicles while driving to avoid unnecessary stop or emergency braking, so as to save fuel and reduce wear on the brake system.
- Do not step on the brake pedal when the vehicle is running, for fear of premature wear and overheating of brake linings and waste of fuel.
  - When driving, select good road surface. If driving on uneven roads, control the vehicle speed to avoid collision or scratches.
  - If the chassis is stained with objects such as excessive dirt, clean them in time to reduce the vehicle's weight and prevent corrosion.
  - Perform regular maintenance on the vehicle to maintain its optimal working condition, as dirty air cleaner, spark plugs, oil, and grease will reduce the engine performance and increase fuel consumption.
  - When starting the engine at a low temperature, drive slowly for a few minutes, and ensure the engine is warmed up before acceleration.
  - Do not open windows when driving at high speed.
  - Properly use the A/C, etc.
  - In case of parking for a long time, please shut down the engine to avoid wasting fuel due to long time idling of engine.

### 5.8.5 Fire prevention

In order to prevent vehicle fires, pay attention to the followings during use:

1. Never store flammables or explosives in the vehicle:
  - In hot summer days, the inside temperature of vehicles parked in the sun can be as high as 70°C or more. If flammables or explosives such as lighters, cleaning agents and perfumes are stored in the vehicle, fire and even explosion will be likely to occur.
  - Items with risk of fire such as lithium batteries or power banks left in the vehicle by passengers are also likely to cause fire.
2. Make sure the cigarette butts are completely extinguished after smoking:
  - If the cigarette butts are not completely extinguished, fire may be caused.
3. It is recommended to regularly drive to the GAC Motor authorized shop for inspections:
  - Also subject all electric lines of the vehicle to regular inspections. Specifically speaking, check whether the connectors, insulation, and fixing positions of electrical components and harnesses are normal, and handle any problems found during inspection in a timely manner.



4. Never modify the electrical circuits or install additional electrical components:
  - Installation of additional electrical consumers (such as high-power audio device) will cause excessive load on the electrical line, causing overheating and even fire of harnesses.
  - Never use fuses that exceed the rated specifications of the electrical consumer or other metal wires to replace the fuses.
5. Precautions for driving:
  - During driving and parking, especially in summer, be sure to check if there are flammables such as hay, dry branches, leaves and wheat stalks under the vehicle, as they may be ignited by the components heated after long-time driving, such as engine exhaust pipe.
  - Do not park the vehicle in places involving serious rat infestation, such as garbage dumps, and do not place items that attract rats, such as snacks in the vehicle, because rats will bite through the harnesses and a fire will be caused therefrom.
6. Always place a lightweight fire extinguisher in the vehicle, and know its operation method:
  - In order to ensure the safety of the vehicle, place a fire extinguisher in the vehicle, and regularly check and replace it; at the same time, be familiar with the operation method of the fire extinguisher, so as to be prepared for handling any unexpected fire accident.

## 6. In-service maintenance

### 6.1 Maintenance instructions

#### Safety precautions

To avoid potential hazards, please read this section before work and confirm that you have the necessary tools and techniques.

- Make sure that the vehicle is parked on a level ground, shut down the engine and apply the parking brake.
- When cleaning parts and components, use the commercially available de-greaser or parts cleaner, instead of gasoline.
- Keep lit cigarettes, sparks, and open flames away from batteries and all fuel system related components.
- When working on batteries or with compressed air, wear goggles and protective clothing.

#### WARNING

**Incorrect vehicle maintenance or driving the vehicle before the problem is solved may cause a traffic accident, resulting in serious injury or death.**

#### Potential hazards of the vehicle

- Carbon monoxide: carbon monoxide in the exhaust gas of the engine is toxic. Be sure to operate the engine in a well-ventilated place.
- Burns: The engine and exhaust system are at high temperature during operation, which can easily cause burns. Therefore, wait till the engine and exhaust system cool down before touching the related parts and components.

#### CAUTION

This section lists some of important safety precautions. We cannot list all the dangers you may encounter during maintenance work.

### 6.2 Interior maintenance

#### Cleaning and maintenance of instruments and plastic parts

Clean the surface of instruments and plastic parts with a clean soft cloth and clean water.

If it cannot be cleaned, it is required to use a special solvent-free plastic cleaning agent for cleaning.

#### CAUTION

Solvent-based cleaning agents can damage plastic parts.

#### WARNING

**It is forbidden to use cab sprays and solvent-based cleaning agents to clean the surface of the instrument panel and airbag assembly. Otherwise, it may loosen the surface and trigger the airbag, which may cause serious injury to occupants.**

### Cleaning and maintenance of carpet

Vacuum the dust on the carpet frequently.

Scrub the carpet regularly with detergent to keep it clean.

#### CAUTION

Please perform the cleaning in strict accordance with the operating instructions of cleaning agents.

#### WARNING

**It is forbidden to add water to the foam cleaner. The carpet shall be kept as dry as possible.**

### Cleaning and maintenance of leather\*

- Vacuum the dust.
- Clean the leather with a clean soft cloth and clean water.
- Wipe the leather dry with another dry soft cloth.
- If the cleaning methods described above are not enough to clean stains, please combine these methods with special leather cleaning soap or detergent.

#### CAUTION

If a leather stain remover is used, wipe it dry with a soft dry cloth as soon as possible.

#### WARNING

**Never leave a soft cloth wet with leather stain remover on any part of the interiors for a long time. Avoid discoloring or breaking the resin or fibers of interior fabrics.**

### Cleaning and maintenance of seat belts

- Pull the seat belt out slowly and keep it being extracted.
- Remove dirt from the seat belt by using a soft brush and neutral soapy water.
- After seat belts dry completely, retract the seat belts.

#### CAUTION

- Wait till the seat belts dry completely before retracting them. Otherwise, seat belt retractors may be damaged.
- Regularly check all the seat belts in the vehicle to ensure that the seat belts are clean and avoid hindering the normal operation of seat belts.

## 6. In-service maintenance

---

### WARNING

- **If the seat belt webbing, connectors, retractor mechanism or buckles are damaged, please go to the GAC Motor authorized shop for replacement as soon as possible.**
- **For the overhaul of an accident vehicle, seat belts must be replaced, no matter whether they are damaged.**
- **Avoid foreign objects or liquids entering the seat belt buckles, which may result in the buckles and seat belts not working properly.**
- **Under any circumstances, it is forbidden to remove or modify seat belts without authorization.**
- **It is forbidden to use chemical cleaning agents to clean the seat belts, for fear of damaging the seat belt webbing and impairing the function of seat belt.**

### Cleaning and replacement of filters

The vehicle is equipped with an air cleaner, an A/C filter, an oil filter, a fuel filter, etc. They aim to filter gases or fluids. If they are too dirty or clogged, the normal operation of corresponding systems will be affected. Therefore, it is recommended to regularly clean or replace the filters at the GAC Motor authorized shop according to the provisions of the Warranty Manual.

## 6.3 Exterior maintenance

### Vehicle washing

Washing the vehicle frequently helps to protect its appearance.

Vehicle washing shall be performed in a cool place, rather than under direct sunlight. If the vehicle is left in the sun for a long time, wait till the vehicle body surface cools down before washing the vehicle.

When using an automatic vehicle washer, be sure to follow the instructions of the operator of the automatic vehicle washer.

### WARNING

**The vehicle power switch must be set to “OFF” position before vehicle washing.**

### CAUTION

The paint surface of the vehicle body is strong enough to withstand the washing of the automatic vehicle washer. However, it is important to pay attention to the effects on the paint surface. The structure of the automatic vehicle washer, the cleaning agent, the filtering state of the clean water, and the type of wax solvent that do not meet the requirements may cause damage to the paint surface.

### Manual vehicle washing

- Rinse the vehicle with plenty of water to remove floating dust.
- Prepare a bucket of water and add a special cleaning agent for vehicle washing to it.
- Gently scrub the vehicle with a soft cloth, sponge or soft brush and rinse it several times from top to bottom.
- Rinse the parts such as wheels and door sills at last. Replace sponges or soft cloth while washing the vehicle.
- After scrubbing, rinse the vehicle thoroughly with plenty of water.
- After washing, carefully dry the paint surface of the vehicle using a soft towel or antelope skin.

### CAUTION

When the vehicle body has dirt such as asphalt, it needs to be cleaned with a special cleaning agent, and then rinsed with clean water to avoid damaging the surface finish of the vehicle body. Check the body for paint peeling and scratches while wiping the body. If any, drive to the GAC Motor authorized shop for touch-up.

When using a steam cleaner or a high-pressure cleaner to wash the vehicle, be sure to be very careful. Be sure to wash the vehicle in accordance with the operation instructions and requirements of the steam cleaner or high-pressure cleaner. Pay attention to the working pressure, temperature and spraying distance:

- When using a steam cleaner or a high-pressure cleaner to wash the vehicle, keep a sufficient water spray distance from the vehicle, and ensure the temperature does not exceed 60°C.

- If the vehicle is equipped with a power sunroof, keep the water spray distance more than 80 cm when washing the vehicle. If the high-pressure cleaner is close to the vehicle, or if excessive pressure or temperature is used, the vehicle may be damaged.
- Do not wash a radar sensor or a parking assist camera with a high-pressure cleaner for a long time; when washing the radar sensor or parking assist cameras, keep the water spray distance more than 30 cm.

### WARNING

- **When washing the vehicle manually, pay attention to personal safety and beware of angular parts at the bottom of the vehicle to avoid being scratched.**
- **When washing the vehicle, pay special attention to the bottom of the vehicle and the inner side of wheelhouses. Do not hurt hands and arms with sharp parts.**
- **Never spray water directly into the engine compartment when washing the vehicle. Otherwise, it will affect the service life of various parts and components in the engine compartment.**

## 6. In-service maintenance

---

### Waxing

Regular waxing can protect the paint surface of the vehicle body and keep the vehicle body clean. In order to effectively protect the paint surface of the vehicle body, it is recommended to apply high-quality hard wax once a year to protect the paint surface against corrosion by external bad environments and to resist light mechanical scratch.

Be sure to wipe the appearance of the entire vehicle dry before waxing. Before waxing the vehicle, please select a high-quality wax protectant. High-quality wax protectant generally falls into the following two types:

- Vehicle body wax: a wax used to protect the paint surface against damage by external bad environments such as sun exposure and air pollution. This type of wax is generally used for new vehicles.
- Polishing wax: a wax which can restore the gloss of the paint surface that has been oxidized or tarnished. This type of wax is generally used to restore the gloss of paint surface.

### Cleaning and maintenance of external plastic parts

External plastic parts are generally washed with clean water, soft cloth and soft brushes. If they cannot be cleaned, please use the special solvent-free plastics cleaner approved by our company.

#### CAUTION

Do not use solvent-based cleaning agents when washing plastic parts. Otherwise, it is easy to damage the plastic parts.

### Washing of window glasses and rearview mirrors

Clean the window glasses and rearview mirrors with alcohol-based glass cleaner, and then wipe the glass surface dry with a clean, lint-free soft cloth or antelope skin.

After curing the surface of the vehicle body, remove the wax residue on the glasses with a special cleaning agent and cleaning cloth. Avoid scratching the wiper blades.

Remove snow from the windows and rearview mirrors using a small brush.

Remove accumulated ice using de-icer spray. An ice shovel can also be used, but special care must be taken to avoid damage to the components, and ice must be shaved in the same direction.

### CAUTION

- It is forbidden to scrape the surface back and forth.
- It is forbidden to remove ice and snow from the windshields and rearview mirrors using warm water or hot water. Otherwise, the windshields may burst.
- If there are residual objects such as rubber, grease and silicone on the glass, they must be removed with a special window cleaner or silicone cleaner.

### Cleaning of wiper blades

- Set the vehicle power switch to the "ON" position and then to the "OFF" position.
- Set the wiper combination switch to the "MIST" position within 10 s. Then the wiper arm stops after moving for half a circle.
- Raise the wiper arm and carefully wipe off the dust and dirt on the wiper blade with a soft cloth.
- After cleaning, gently lower the wiper arm back to the windshield.
- Set the vehicle power switch to the "ON" position. Then the wiper automatically returns to the original position.

### CAUTION

- Be careful when lowering the wiper arm to prevent it from falling and hitting the windshield instantly.
- The wiper blades are coated with a layer of graphite which makes the wiping operation smooth and does not produce scraping noise. Solvent-based cleaning agents, hard sponges and sharp objects can damage the graphite layer. Damaged graphite layer will increase the wiping noise of the wiper, and the wiper shall be replaced in time.
- In winter or cold conditions, be sure to check whether the wiper blade is frozen together with the windshield before using the wiper. If so, perform de-icing first. Otherwise, the wiper blade and wiper motor will be damaged.

### Cleaning and maintenance of wiper cover

Try to avoid parking the vehicle under a tree frequently/for a long time. In case of leaves or other debris on the surface of the wiper cover, please clean them in time.

### Maintenance of sealing strips

Frequent and proper protection of the rubber sealing strips of the doors, windows and other parts of the vehicle is intended to maintain their flexibility and prolong their service life. Such protection can also improve the tightness, make the door easy to open, reduce the impact sound of closing the door, and prevent freezing in winter.

When performing maintenance on sealing strips, remove dust and dirt from surfaces using a soft cloth. Apply special protective agent to rubber sealing strips regularly.

### Cleaning and maintenance of wheels

Regularly remove anti-skid salts on the wheels and debris on the brake linings, which can keep the wheels aesthetic, maintain the surface smooth and prolong the service life of wheels. It is recommended to perform the following operations regularly:

- Remove anti-skid salts on the wheels and debris on the brake linings using acid-free wheel cleaner every two weeks.
- Apply high-quality hard wax to the alloy wheels every three months.

## 6. In-service maintenance

### CAUTION

- It is prohibited to maintain the wheel surface with vehicle polish or other abrasives.
- The wheels with damaged protective coating on surface must be repaired in time.
- Using a high-pressure cleaner may cause permanent visible or invisible damage to the wheels, resulting in serious injury or death.
- It is forbidden to use cluster head nozzles to spray the tires. Otherwise the tires will be damaged, causing traffic accidents.

## 6.4 Inspecting and adding fluids

### 6.4.1 Fuel

As the amount of fuel decreases when the vehicle is running, the fuel gauge scale will gradually decrease. => See page 40

When the fuel level is too low, the yellow indicator lamp flashes, and the instrument cluster will give an alarm message. At this time, fuel shall be added as soon as possible



### Adding fuel



- Press and hold the fuel tank cap opening button  to make the fuel tank cap pop up.



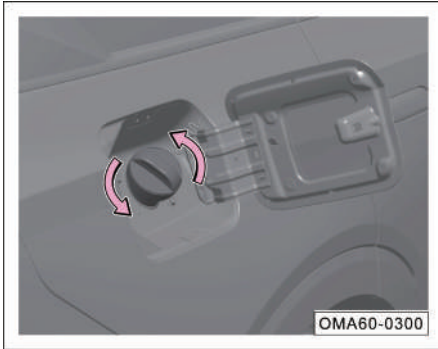

- Open the fuel tank cap completely, and slowly unscrew the fuel filler cap counterclockwise as arrowed. Keep the fuel filler cap at the original place for a while before it is unscrewed completely to allow fuel tank to release the fuel vapor inside, and then remove it.



- Hang the fuel filler cap on the inner side of the fuel tank cap and start adding fuel.
- After adding the fuel, tighten the fuel filler cap clockwise till a click is heard, which indicates that the fuel filler cap has been tightened.

### **i** NOTE

Grade of fuel: 95# or above high-quality unleaded gasoline.

### **i** NOTE

This model complies with China VI emission standards. The fuel supply system of China VI is designed with a closed fuel and gas recovery system. During refueling, the fuel gun switch may be triggered due to high ambient temperature or high fuel flow rate, and the fuel gun is switched off when the fuel tank is not filled fully. This is a normal phenomenon. At this time, the refueling speed shall be slowed down.

### **👁** CAUTION

Low-grade fuel or substandard fuel may damage the engine or make the engine fail to meet performance requirements.

## 6. In-service maintenance

### WARNING

- At any time, be sure to shut down the engine when refueling, and pay attention to open flames and fire.
- Please avoid contact of fuel with skin or clothing.
- Please refuel the vehicle according to the vehicle fuel grade. If fuel not complying with the regulations is added accidentally, do not start the engine. Please contact the GAC Motor authorized shop immediately for treatment.

### Emergency opening of fuel tank cap

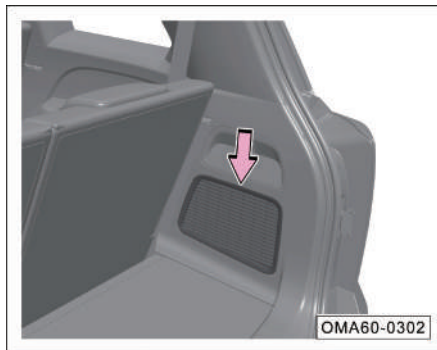

An emergency cable for the fuel tank cap is installed on the right side of the trunk. In special circumstances, the fuel tank cap can be opened from the inside:

- Pry open the trim cover as arrowed.

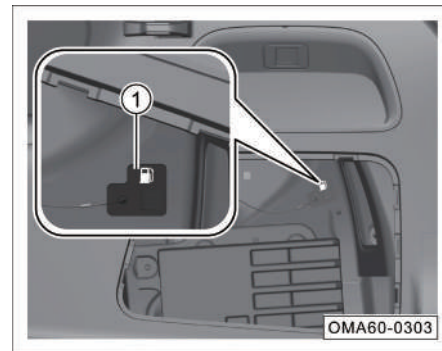

Pull the emergency cable ① to open the fuel tank cap.

### 6.4.2 Engine oil

#### Function of engine oil

Engine oil has functions such as lubrication, sealing, cooling, anti-rusting and cleaning.

#### Specifications of engine oil

The engine has been filled with high-quality engine oil, which can be used in the year-round climate except for extreme cold weather before delivery.

When purchasing engine oil, please check whether the specifications indicated on the outer packaging of the engine oil are suitable for the engine of this vehicle.

#### i NOTE

- Engine oil grade: SN and above.
- Oil viscosity: SAE 5W-30.

#### ⚠ WARNING

**Always use the engine oil approved by our company. Otherwise, the ensuing engine damage will not be covered by the warranty.**

#### i NOTE

- Be sure to go to the GAC Motor authorized shop to change the engine oil according to the period specified in the *Warranty Manual*.
- If the vehicle is running under severe conditions, fuel with high sulfur content is used, engine idles for a long time (e.g., a taxi), the vehicle is driven in a high-dust area, the vehicle often tows a trailer, or the vehicle is used in an alpine area, the maintenance cycle shall be shortened and the maintenance times shall be increased.

#### Engine oil pressure warning lamp

When driving, if the warning lamp  comes on, be sure to stop the vehicle in a safe place and shut down the engine. After the engine cools down, check the oil level.

If the engine oil level is normal, but the warning lamp is still on after the engine is started, do not continue to start the engine. In this case, contact the GAC Motor authorized shop timely for inspection.

#### ⚠ WARNING

- **Ignoring the warning lamps and related warning instructions may damage the engine.**
- **The low oil pressure warning lamp cannot indicate the oil level, and the oil level must be checked regularly.**

## 6. In-service maintenance

### Inspecting the oil level

Be sure to check the oil level regularly. Park the vehicle on a level ground, apply the park brake, and shut down the engine. After the engine cools down, open the engine hood and check the oil level.

#### WARNING

- Be extremely careful while working in the engine compartment.
- The engine compartment is a high-risk area. Be sure to read and follow the relevant warning instructions carefully before opening the engine hood.

#### NOTE

While checking the oil level, ensure the engine is cold.

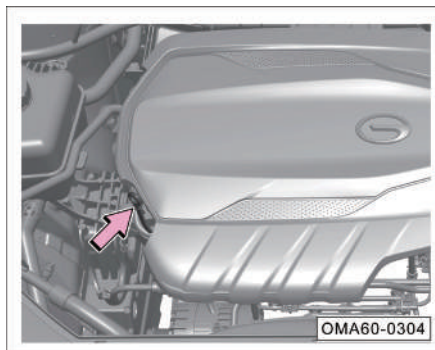

- Pull out the oil dipstick.

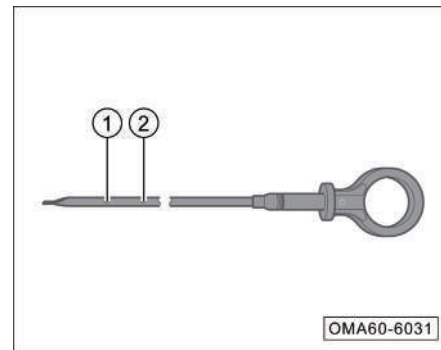

- Wipe off the oil stains on the dipstick using a clean cloth, and then insert the oil dipstick to the end.
- Pull out the dipstick again and read the measured oil level: The oil level shall be between the minimum scale mark ① and maximum scale mark ②.
- If there is too little engine oil, please add engine oil in time. Otherwise, poor lubrication will damage the engine.

### Adding engine oil

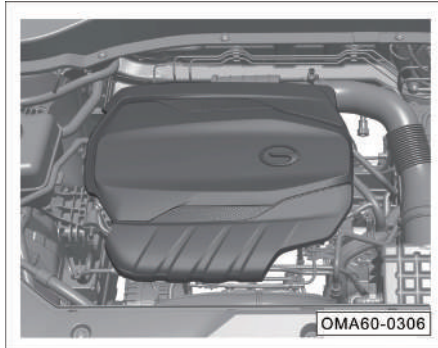

After checking the oil level, if required, add engine oil following the steps below:

- Lift up to remove the engine upper guard plate.

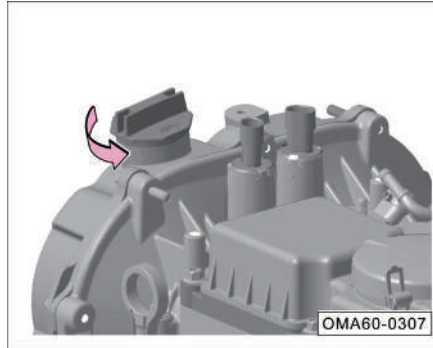

- Unscrew the oil filler cap counterclockwise.
- Add small amounts of engine oil repeatedly, and check the oil level after each filling.
- When the oil level is close to the maximum scale mark ②, indicating the engine oil is sufficient, stop adding oil, refit the oil filler cap and tighten it clockwise.

### WARNING

- Be careful while adding the engine oil. Do not spill it. If the engine oil gets on skin, be sure to rinse the skin thoroughly.
- If too much oil is added, do not start the engine. In this case, please contact the GAC Motor authorized shop as soon as possible. Otherwise, the three-way catalytic converter may be damaged.
- After filling, be sure to tighten the oil filler cap to prevent the engine oil from splashing when the engine is being started, for fear of a fire.
- Since engine oil is toxic, it shall be stored in the original container and kept out of children's contact to avoid poisoning due to accidental ingestion.
- Do not add any lubricants to the engine oil. Otherwise, the engine will be damaged. Engine failure caused by adding lubricants is not covered by the warranty.

## 6. In-service maintenance

### 6.4.3 Coolant

#### Function of coolant

Coolant has functions such as cooling, anti-freezing and anti-corrosion.

#### Specifications of coolant

The cooling system has been filled with coolant before delivery. This coolant can be used in the year-round climate except for extreme cold weather. It can also prevent corrosion of cooling system alloy components and system scale incrustation.

#### **i** NOTE

- Specifications of coolant: DF-6, -35°C .
- Be sure to go to the GAC Motor authorized shop to change the coolant according to the period specified in the *Warranty Manual*.
- If the coolant discolors, the maintenance cycle shall be shortened and the coolant shall be changed at the GAC Motor authorized shop.

#### High engine coolant temperature indicator lamp

When driving, always observe the indication of the engine coolant temperature gauge to know the coolant temperature.

If the coolant temperature is too high, the indicator lamp  on the instrument cluster comes on in red, and an alarm message is given to prompt the driver; at this time, the vehicle must be stopped in a safe place and the engine shut down. After the engine cools down, check the coolant level.

If the coolant level is normal but the indicator lamp is still on after the engine is started, do not continue to start the engine. In this case, contact the GAC Motor authorized shop timely for overhaul.

#### Inspecting the coolant level

Be sure to check the coolant level regularly. Park the vehicle on a level ground, apply the parking brake, and shut down the engine. After the engine cools down, open the engine hood and then check the coolant level.



#### WARNING

- **Be extremely careful while working in the engine compartment.**
- **The engine compartment is a high-risk area. Be sure to read and follow the relevant warning instructions carefully before opening the engine hood.**
- **If steam or coolant flows out from the engine compartment, do not open the engine hood, for fear of burns; wait till there is no steam or coolant overflowing and the engine cools down before opening the engine hood.**

## 6. In-service maintenance

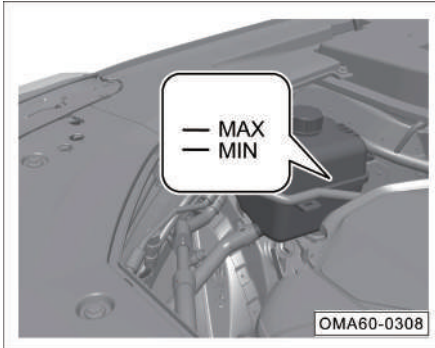

Check whether the coolant level in the expansion tank is between the upper limit mark "MAX" and the lower limit mark "MIN".

### **i** NOTE

When the engine is not cooled, the coolant level will be high, and there will be errors in checking the coolant level.

### **eye** CAUTION

When the coolant level is lower than the lower limit mark "MIN", coolant must be added. Insufficient coolant will affect the cooling effect and cause engine damage.

### Adding coolant

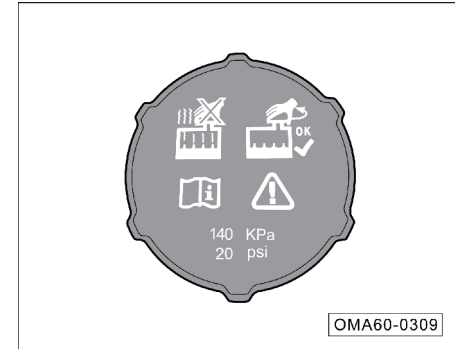

After checking the coolant level, if required, add coolant following the steps below:

- Wrap the expansion tank cap with a thick cloth and unscrew it counterclockwise.
- Add the coolant until the coolant level reaches the "MAX" mark.
- Turn the expansion tank cap clockwise to the locking point.

## 6. In-service maintenance

---

### CAUTION

- When the engine is not cooled, the cooling system is under high pressure. In this case, do not open the expansion tank cap, otherwise the emerging coolant will cause scald.
- Coolant can only be added after the engine has cooled down. The coolant level after filling must not exceed the maximum scale mark "MAX". Otherwise, when the engine is started and the cooling system is under high pressure, coolant will overflow.
- Only fresh coolant is allowed to be added.

### WARNING

- **It is forbidden to mix coolant that is not approved by our company into the original coolant, otherwise the engine may be damaged due to incompatibility.**
- **In case of emergency, if other coolant is used or pure water is added, go to the GAC Motor authorized shop to clean the cooling system and change the coolant in time.**
- **If the too much coolant is consumed or it is consumed too fast, there may be a leak in the cooling system. In this case, please go to the GAC Motor authorized shop for inspection in time.**
- **Coolant must be contained in the original container, and kept out of children's contact to avoid poisoning due to accidental ingestion.**



### 6.4.4 Windshield washer fluid and wiper blades

#### Adding windshield washer fluid

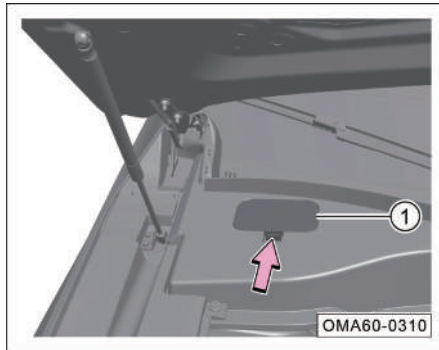

- Press the buckle as arrowed to remove the cover ①.



- If the level of the washer fluid is too low, the washer fluid shall be added in time.
- Install the cover ① after adding the fluid.

#### CAUTION

Do not mix and use the windshield washer fluid with other cleaning liquids. Otherwise, the washer fluid will decompose and block the nozzle of the windshield washer.

#### WARNING

- Be extremely careful while working in the engine compartment. Before operation, be sure to carefully read and follow the relevant warning instructions.
- Do not misuse coolant or any other additives as windshield washer fluid. Otherwise, oil stains will be left on the windshield during cleaning of the windshield, which will affect the visibility and easily cause accidents.
- It is forbidden to use windshield washer fluid with more than 10% ethanol content. Under high temperature environment, this type of windshield washer fluid will cause corrosion of lamps and crack lamps. It is recommended to use methanol washer fluid.

## 6. In-service maintenance

### Replacing front windshield wiper blades

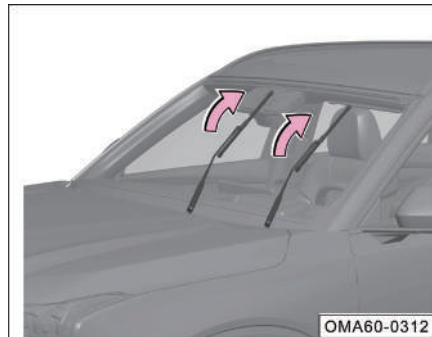

- Set the vehicle power switch to the "ON" position and then to the "OFF" position.
- Set the wiper combination switch to MIST within 10 s. The wiper arm will stop after running for half a circle.

#### i NOTE

With the wiper switch in the "OFF" position, if the soft button on the right of "Wiper Maintenance Mode" is touched on the AV system "Settings→Body Accessories→Other Accessories" interface, the wiper arm will stop after moving for half a circle. If the soft button on the right is touched again, the wiper arm will be reset.

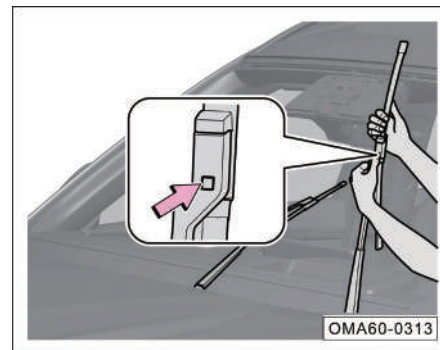

- Lift up the wiper arm, and press the lock button as arrowed to remove the wiper blade.
- Disconnect the wiper blade from the washer hose, and remove the wiper blade.
- Slowly lower the wiper arm.
- Install the new wiper blade into the wiper arm in reverse steps. It is installed in place when a "click" is heard.
- Gently put the wiper arm back on the windshield.
- Set the vehicle power switch to the "ON" position or start the engine. Then the wiper automatically returns to the original position.

### Replacing rear windshield wiper blades

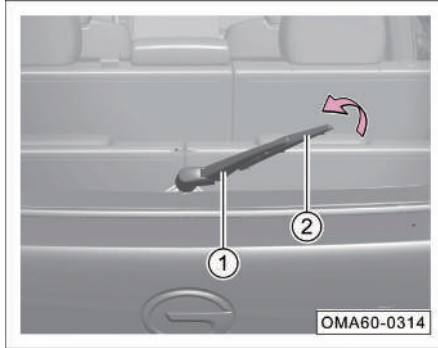

- Hold the wiper arm ① by hand, and push the wiper blade ② as arrowed to remove it.
- Slowly lower the wiper arm.
- Install the new wiper blade into the wiper arm in reverse steps. It is installed in place when a “click” is heard.
- Gently put the wiper arm back on the windshield.

If replacing wiper blades is required, it is recommended to go to the GAC Motor authorized shop for replacement.

#### CAUTION

- When lifting the wiper arm, please grasp the wiper arm with hands, rather than grasp the soft wiper blade.
- New wiper blades with the same length and specifications as the previous ones must be used.
- Be careful while lowering the wiper arm to prevent it from falling and hitting the windshield instantly.
- The status of the wiper blades must be checked regularly, and the wiper blades must be replaced as specified. Damaged wiper blades must be replaced in time.
- Excessively worn or dirty wiper blades are very easy to scratch the windshield and will affect the field of vision when used, reducing driving safety.

### 6.4.5 Brake fluid

#### Function of brake fluid

Brake fluid is used to transmit power in the hydraulic brake system of the vehicle.

The brake fluid is water-absorbent, so it can continuously absorb moisture in the surrounding air during use. If the brake fluid stays in the system for too long and absorbs too much moisture, air resistance will generate in the system pipeline during braking, reducing the braking effect and impairing driving safety; it may even cause the complete failure of the brake system, resulting in accidents. Therefore, be sure to go to the GAC Motor authorized shop to check the brake fluid level or change the brake fluid according to the period specified in the *Warranty Manual*.

#### NOTE

Specifications of brake fluid: DOT4.

## 6. In-service maintenance

### WARNING

- Using waste brake fluid or using brake fluid not applicable to the vehicle will remarkably reduce the braking effect and even cause the brake system to fail! The company does not assume any responsibility (including quality guarantee) for vehicle failures and damage caused thereby.
- Brake fluid in use must meet the criteria and be fresh.

### Brake system indicator lamp

When the vehicle is running, if the  indicator lamp comes on in red, and the instrument cluster displays the information "Please add brake fluid", be sure to immediately stop the vehicle at a safe place and check whether the brake fluid level is normal.

### Inspecting brake fluid level

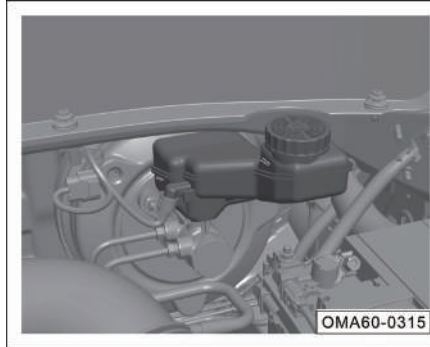

When the engine cools down, remove the rear upper guard plate of engine compartment, and check whether the brake fluid level is between the maximum scale mark "MAX" and the minimum scale mark "MIN".

During vehicle use, the brake fluid level will slightly drop due to the worn brake linings and automatic adjustment.

If the brake fluid level drops significantly in a short period of time or drops below "MIN", it indicates that the brake system may leak.

### NOTE

- Be sure to read and follow the relevant warning instructions carefully before opening the engine hood.
- After check of the brake fluid level, if the fluid level is below "MIN", brake fluid must be added.
- If the brake system warning lamp does not go out or comes on again after the brake fluid is added, there may be a leak in the brake system, causing the brake fluid level to drop quickly, or the brake system malfunctions. In this case, do not continue to drive and contact the GAC Motor authorized shop in time for inspection.

### Adding brake fluid

In order to ensure the normal operation of the brake system, the added brake fluid shall meet the specifications:

- Open the brake fluid reservoir cap counterclockwise.
- Add fresh brake fluid to the maximum scale mark "MAX" and stop adding.
- Tighten the brake fluid reservoir cap clockwise.

#### CAUTION





The brake fluid will corrode the paint surface of the vehicle body. Brake fluid splashed on the paint surface shall be wiped off in time.

#### WARNING

- **Brake fluid is toxic. It must be contained in the original sealed container, placed in a safe place, and kept out of children's contact to avoid poisoning due to accidental ingestion.**
- **Brake fluid must be stored in accordance with environmental protection laws.**

### 6.4.6 Battery

#### Warning symbols and instructions for battery operation

	Goggles must be worn during operation!
	The battery electrolyte is highly corrosive. Protective gloves and goggles must be worn during operation!
	Open flames, sparks, uncovered lamps and smoking are prohibited in the workplace!
	Very explosive gas mixture is generated when the battery is being charged!
	Children must stay away from electrolytes and vehicle batteries!

In case of unfamiliarity with the operation process or no special tools, never carry out any operations on the electrical system of the vehicle, and contact the GAC Motor authorized shop.

## 6. In-service maintenance

### Charging system warning lamp

The warning lamp is used to indicate alternator failure.

This  warning lamp will come on when the engine is not started with the vehicle power switch set to “ON” position, and will go out after the engine is started.

When the vehicle is running, if the warning lamp comes on, it indicates that the alternator is no longer charging the battery. In this case, please go to the GAC Motor authorized shop for inspection in time.

### Inspecting the battery

The battery must be checked according to the period specified in the *Warranty Manual*.

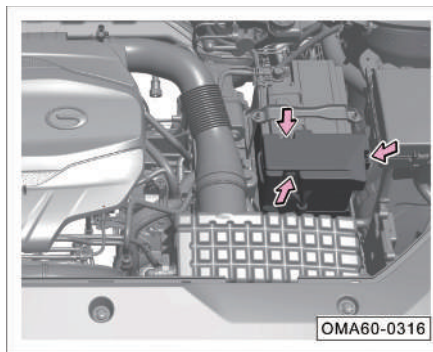

- Remove the rear upper guard plate of engine compartment.
- Remove the cover of the battery positive terminal.
- Check the connection of the battery connector and the cable for corrosion or looseness; check the appearance of the battery for cracks, swelling, etc. If the phenomena above are found, please go to the GAC Motor authorized shop for inspection in time.
- If the vehicle is not in use for a long period of time, check the battery condition frequently.

### NOTE

- If the battery is low in power or damaged, making the engine difficult to start, please contact the GAC Motor authorized shop to charge or replace the battery.
- If it is required to replace the battery, please go to the GAC Motor authorized shop for replacement; if a wrong type of battery is used, the vehicle may not run due to incompatibility or the electrical system may fail.

### Instructions for using the battery

After the engine is turned off, the battery will quickly discharge when an electrical consumer on the vehicle is being used:

1. Do not use an electrical consumer on the vehicle for a long time after the engine is turned off.
2. While leaving the vehicle, make sure that the doors are closed and all electrical consumers (e.g., lamps) are turned off.

#### CAUTION

- If the vehicle can not be started due to depleted battery, please try emergency start. If the vehicle still can not be started, please contact the GAC Motor authorized shop for inspection.
- To avoid damage to the electrical system of the vehicle, never connect power generation equipment such as solar panels or vehicle battery chargers to a power outlet.
- The battery contains toxic substances such as sulfuric acid and lead, so it must be disposed of properly and must not be treated as ordinary household waste.

### 6.5 A/C filter

#### Inspecting and cleaning the A/C filter

Check or clean the A/C filter regularly according to the provisions in the *Warranty Manual*. If the vehicle is running in a dusty environment and the A/C filter is too dirty, it is recommended to replace the A/C filter earlier.

The A/C filter is located inside the front passenger's glove box. When removing the A/C filter, it is more complicated to disassemble the parts. In order to avoid unnecessary component damage, it is recommended to check and clean or replace the A/C filter at the GAC Motor authorized shop.

### 6.6 Replacing bulb

#### Instructions for replacing bulbs

All vehicle lamps are LED lamps, which cannot be disassembled or replaced individually. If the bulb is damaged or malfunctions, please go to the GAC Motor authorized shop for inspection in time.

#### WARNING

**It is forbidden to modify external lighting devices and tell-tales.**

## 6. In-service maintenance

### 6.7 Wheels

#### WARNING

Within the first 500 km, the road adhesion of new tires is unlikely to reach the best condition. Therefore, the vehicle shall be driven carefully at a moderate speed to prevent accidents.

- Inadequate road adhesion of tires not subject to running-in period or excessively worn can directly affect the braking effect.
- If it is found that the vehicle is abnormally vibrating or deviating, stop the vehicle immediately and check whether the tires are damaged.
- If it is found that the tires are unevenly and excessively worn, please go to the GAC Motor authorized shop for inspection as soon as possible.

#### WARNING

If tires burst or leak when the vehicle is running, it is very easy to cause serious traffic accidents.

- Never use damaged tires and wheels, or use tires of which the treads have been worn to the wear indicators. Otherwise, it is very easy to cause an accident, because such tires may burst during driving, causing traffic accidents and injury. Such tires and wheels shall be replaced in time.
- The tire pressure must meet the regulations. Otherwise, it may cause an accident. If the tire pressure is insufficient, the continuous high-speed running of the vehicle will cause the tire to deflect, and the tire is extremely easy to overheat, which may cause tread separation or tire burst.
- Be careful not to expose the tires to chemicals, oil, grease, fuel and brake fluid.

#### WARNING

- Never use old wheels and tires of unknown origin under any circumstances. Although such wheels and tires do not have visible damage, they may have been damaged. During driving, they may cause the vehicle to lose control and lead to traffic accidents.
- It is not recommended to use recycled tires. For such tires, the carcass may degrade as the service time passes, and the durability may also be restrained, impairing the driving safety.



### Precautions for wheel failure

- When driving over curbs or similar obstacles, keep a slow speed in the vertical direction of the obstacles as much as possible.
- Be careful not to let the tires contact with grease, oil and fuel.
- Regularly check the damage status of tires (i.e., splitting, abrasion, shedding, deformation or bulging).
- Regularly remove debris embedded in the grooves of the tire pattern.

### Instructions for storing tires

- Before removing the tire, make a mark on the tire to indicate the rotation direction of the tire. Refit the tire according to the mark to ensure the rotation direction and the dynamic balance of the wheel are unchanged.
- Store the removed wheels or tires in a cool, dry place, and preferably in a dark place.
- The tire mounted on the rim must not be stored upright.

### New tires and wheels

- Select the new tire and wheel carefully, and make sure that the dimensions, load range, rated speed and structure type of new tire are the same as those of original one.
- Replace at least two tires on the same axle at the same time, rather than only one tire individually.
- Do not use tires of different dimensions or types, and do not mix summer tires, all-season tires and winter tires in use.
- Once wheels are installed, check whether the tightening torque of the wheel bolts ( $125\pm 10\text{Nm}$ ) meets the requirements.

### Non-full-size spare tires

Spare tires and standard tires are different in aspects such as structure, pattern, speed rating and load index, and cannot be exchanged.

After emergency use of the spare tire, it is necessary to drive safely to the GAC Motor authorized shop or the wheel repair shop as soon as possible to replace it with a full-size spare tire, so as to avoid the hidden safety hazards of long-term use of the spare tire.

#### **WARNING**

- **Spare tires can only be used temporarily for emergency, and the maximum driving speed shall not exceed 80 km/h.**
- **The storage and service life of spare tires is 6 years. It is prohibited to use them beyond the time limit.**

## 6. In-service maintenance

### Summer tires

Summer is a rainy season. The tire tread depth directly affects the driving safety in rainy days. In summer, when the tire tread depth is less than 3 mm, there is a high risk of water slippage.

### Winter tires

Winter tires still have good grip performance when roads are covered with snow and ice. The specially designed rubber tread makes the tires less affected by low temperature environment and excellent braking ability, ensuring driving safety.

- Use winter tires on all the four wheels.
- Only use radial winter tires of the same dimensions, load range and rated speed as original ones and approved for this vehicle.

- Please note that the tread of winter tires shall have patterns deep enough (tread depth not less than 4 mm; otherwise, the applicability in winter will be limited).
- After installation of tires, check the tire inflation pressure.

### WARNING

- **Winter and summer tires are designed according to their respective typical lane conditions under the corresponding seasonal conditions. It is recommended to use winter tires in winter. At low temperatures, the adaptability of summer tires is significantly poorer, thereby losing road adhesion and braking ability.**
- **If summer tires are used in severe cold conditions, cracks may appear on the tires, thereby completely damaging the tires, and causing excessive tire noise and loss of balance.**

### WARNING

- **Winter tires may lead to decreased traction force of the vehicle on dry roads, increased road noise and shortened service life of tread. Please pay attention to the performance change of the vehicle in terms of maneuvering and braking after the winter tires are used.**
- **Please note that the maximum speed for winter tires is relatively low. Do not exceed the allowable maximum speed for the tires.**
- **Please note that replace the winter tires with summer tires in time in order to ensure driving safety and performance when driving in the environment at the atmospheric temperature rising above 7 °C .**
- **When driving with winter tires, if a spare tire is installed, unstable steering characteristics may occur due to different tires, weakening driving stability. In this case, driving styles need to be adjusted and driving shall be performed carefully.**

### Inspecting tire pressure

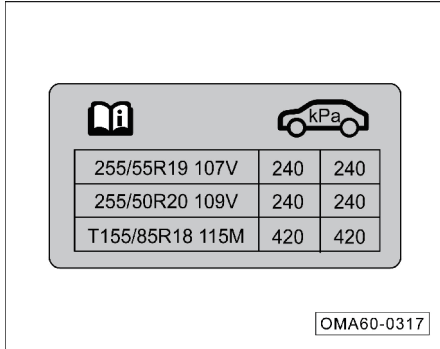

The standard tire pressure data label of the original tire of this vehicle is attached to the B pillar on the driver's side.

- Check the tire pressure applicable to the vehicle from the data label (the listed pressure applies to both summer and winter tires).
- Unscrew the valve cap (if the valve cap is missing, a new one shall be provided in time).
- A high-quality tire pressure gauge is required to check the tire pressure. It is impossible to determine whether the tire pressure is appropriate only by visual inspection.

- Attach the tire pressure gauge to the valve.
- For inspection of tire pressure, the tire must be in a cold state. When the temperature increases, the tire pressure can be slightly higher than the specified value, and it is not necessary to reduce the tire pressure.
- Balance the weight of occupants and luggage, avoid slopes and adjust tire pressure according to vehicle load.
- Check the tire pressure of the spare wheel or emergency spare wheel at the same time.
- Install and tighten the valve cap.

### i NOTE

- The current tire pressure of the wheel can be checked through the information on the instrument cluster display for some models.
- Be sure to refit the valve cap to the valve core. The valve cap can prevent dust and moisture from entering the tire.

### ⚠ WARNING

- **Abnormal tire pressure may cause tire burst, resulting in a traffic accident, injury or even death.**
- **Check the tire pressure at least once a month or before long-distance driving. The tire pressure must meet the specified requirements to prevent accidents.**
- **Insufficient tire pressure will exacerbate tire deflection, and tires are extremely prone to overheating, which may lead to tread separation and tire burst.**
- **Abnormal tire pressure, too low or too high, will cause early wear of tires and reduce the maneuvering stability of the vehicle.**

## 6. In-service maintenance

### Service life of tires

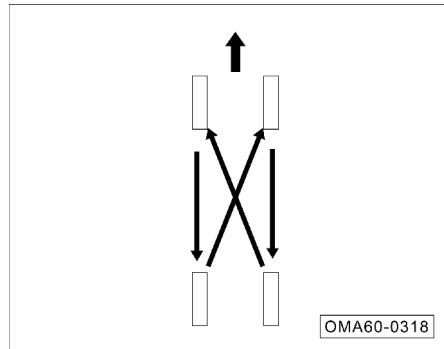

Service life of tires depends on tire pressure, driving style and tire assembly conditions.

If the front tires are worn more serious than the rear tires, it is recommended to perform tire rotation for the front and rear wheels as shown, so as to make the service life of all tires about the same.

### Tread wear indicator

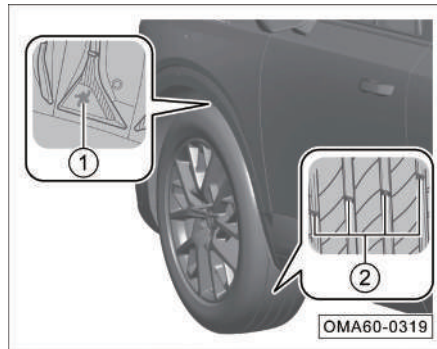

The mark ① is used to indicate the wear condition of the tire outer circle pattern. If the tire outer circle pattern wears to the condition as shown, the tire can no longer be used safely and must be replaced immediately.

The tread wear indicator ② is 1.6 mm in height. If the tread pattern wears to the indicator surface, the tire can no longer be used safely and must be replaced immediately.

### Wheel balance

The wheels of the new vehicle are already balanced. Due to various reasons, the wheels may go unbalanced during operation, which can be manifested by the vibration of the steering mechanism.

Because unbalanced wheels can cause excessive wear on the steering system, wheel suspension mechanism and tires, the wheels shall be rebalanced.

In addition, wheels must be rebalanced after installation of a new tire or tire repair for any wheel.

### Wheel misalignment

Wheel misalignment will cause uneven and excessive wear of the tires, affecting driving safety. If uneven and excessive wear of the tires is found, please go to the GAC Motor authorized shop to check the wheel alignment in time.

### 6.8 Tire chain

In winter, driving in harsh environments such as snowy or icy roads can increase the degree of tire wear or cause other failures. To reduce failures in winter, the following opinions must be followed:

- When driving in deep snow, it is necessary to install tire chains on the tires. In this case, be sure to choose an equivalent product whose size and type meet the specifications of the tires on the vehicle. Failure to do this will adversely affect the performance and safety of the vehicle. Moreover, operations such as full-load driving, speeding, emergency acceleration, emergency braking, and emergency turning are potentially dangerous.
- During deceleration, make full use of the engine braking function. Emergency braking on snowy or icy roads will cause the vehicle to drift and slip. Maintain an appropriate safety distance from the vehicle in front, step on the brake pedal slightly, and pay attention to that installing tire chains on the tires can increase certain friction force, but can not prevent side slipping.

#### NOTE

Various countries and regions have different regulations on tire chains. Before assembling tire chains, please refer to the laws and regulations of the corresponding country and region. Do not install tire chains without understanding the laws and regulations of the corresponding country and region that may restrict the use of tire chains.

#### CAUTION

- For installation of tire chains on all tires, ensure that the vehicle can be driven in a balanced manner in all weathers. It shall be borne in mind that after installation of tire chains, the vehicle may be underpower. Even if the road surface is in good condition, drive carefully. While driving, neither exceed the specified speed limit of tire chains nor exceed 50 km/h, whichever is lower.

#### CAUTION

- If tire chains are installed on the tires, the size and type of tire chains shall be consistent with those of the standard tires of the vehicle. Otherwise, the driving safety and maneuvering of the vehicle will be adversely affected.
- Tire chains must be installed in pairs on the front wheels rather than on the rear wheels.
- Do not install the tire chain on an emergency spare tire. If a spare tire is installed on the front wheel and a tire chain is required, be sure to exchange the positions of the spare tire and the rear tire.
- Do not use tire chains on dry ground. After driving to snow-free roads, remove tire chains.
- After installing the tire chains as closely as possible to the front tires, drive 0.5~1.0 km, and then tighten the tire chains again.

## 7. Technical data

### 7.1 VIN

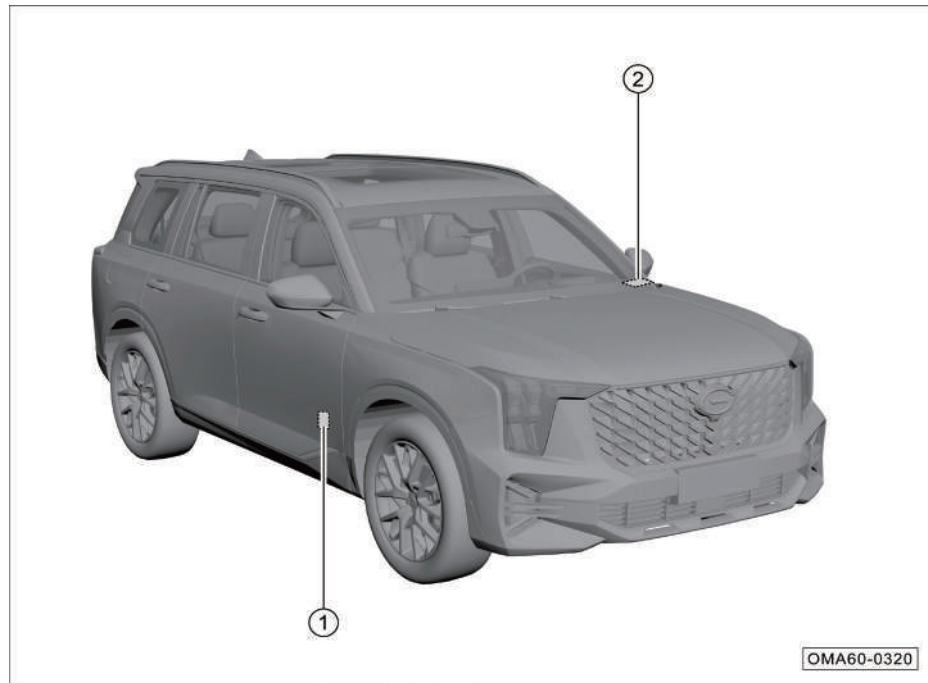

The locations of the vehicle identification number (VIN) is shown in the figure:

- ① VIN: under the carpet in front of the front passenger's seat.
- ② VIN: on the left side of the instrument panel.

#### **i** NOTE

The position indication and quantity of vehicle identification number (VIN) are not complete. Please refer to the actual vehicle.

### OBD DLC

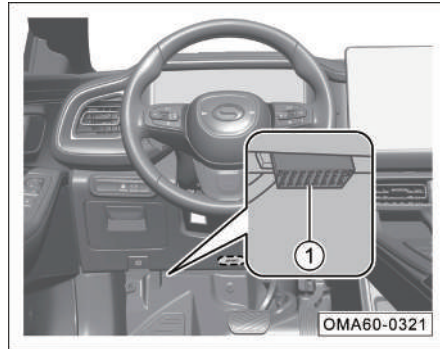

The OBD DLC ① for reading the electronic VIN is located at the lower left of the instrument panel. Data such as the electronic VIN and vehicle status information can be read through a special diagnostic scan tool.

### i NOTE

If you need to buy a diagnostic scan tool, please go to the GAC Motor authorized shop for consultation and purchase.

### Vehicle nameplate



The vehicle nameplate is attached on the B-pillar on the driver side.

### Engine model and factory number

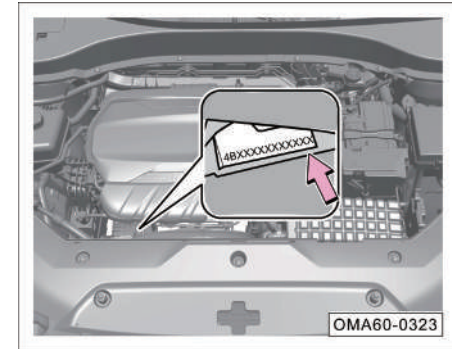

Engine model and factory number as arrowed are indicated on the engine block (behind the alternator).

## 7. Technical data

### 7.2 Dimensions & parameters of vehicle

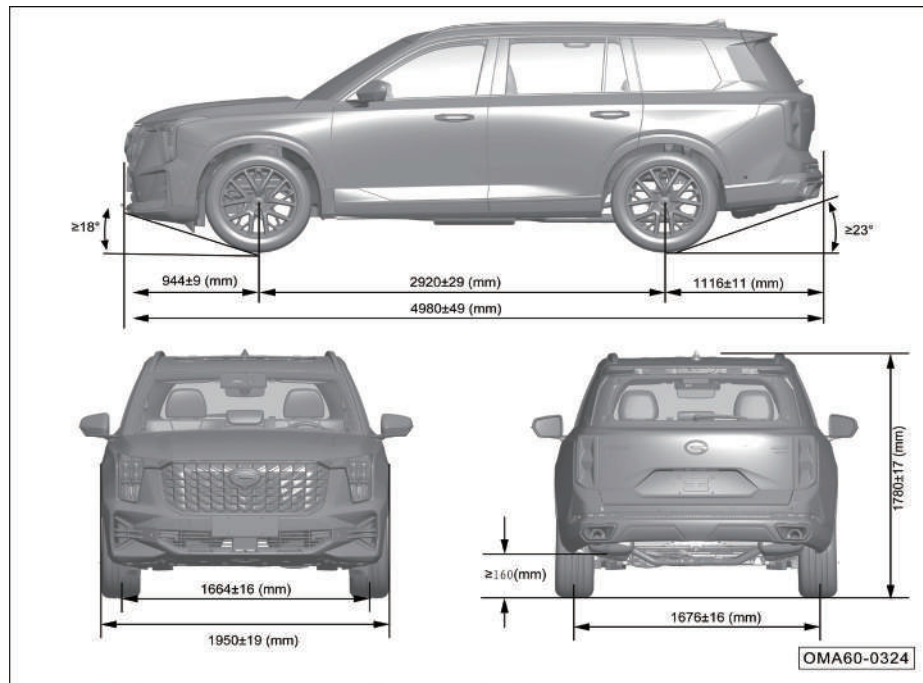

#### Dimensions

Item	Parameters		
	Numerical value	Unit	
Overall length	4980±49	mm	
Overall width	1950±19	mm	
Overall height	1780±17	mm	
Wheelbase	2920±29	mm	
Wheel track	Front wheel	1664±16	mm
	Rear wheel	1676±16	
Front overhang	944±9	mm	
Rear overhang	1116±11	mm	
Minimum ground clearance (full load)	≥160	mm	
Approach angle (full load)	≥18	°	
Departure angle (full load)	≥23	°	

Note: external rearview mirrors (respective one on the right and left) near the junction of the lower end of the A pillar and the front door and the antenna above the rear of the roof are not included in the overall width.



7.3 Vehicle mass & parameters of engine and fluids

Mass

Vehicle model	Kerb mass of vehicle (kg)				Gross vehicle weight rating (kg)		
	VIN (first eight characters)	Kerb mass (kg)	Front axle load	Rear axle load	Gross vehicle weight rating	Front axle load	Rear axle load
GAC6501JDA6A	LMGJU1G5	1880	1035	843	2460	1159	1301
	LMGJU1G8	1920	1050	870			
GAC6501JDA6B	LMGJU3G5	2000	1076	924	2556	1192	1364
	LMGJU3G8	2000	1076	924			
	LMGJU3G5	2030	1092	938			

## 7. Technical data

---

### Comprehensive parameters

Item	Corresponding model parameters		Unit
	GAC6501JDA6A	GAC6501JDA6B	
STT	Non-STT	Non-STT	
Seating capacity	7		Person
Minimum turning diameter	≤12.2		m
Maximum gradeability	≥40		%
Maximum speed	≥210	≥200	km/h
Comprehensive fuel consumption	≤8.5 (NEDC) 13.2 (CAFE)	≤9.0 (NEDC) ≤12.5 (CAFE)	L/100km

## 7. Technical data

### Parameters of engine

Model	4B20J1
Layout	Front mounted, transverse layout
Type	Gasoline engine, spark-ignition, in-line, four-cylinder, four-stroke, water-cooled, GDI, double overhead camshaft, exhaust gas turbocharging
Number of cylinders	4
Ignition order	1-3-4-2
Bore (mm)	83
Travel (mm)	92
Displacement (mL)	1991
Compression ratio	(10±0.3): 1
Rated power/speed (kW/(r/min))	185/5250
Maximum net power/speed (kW/(r/min))	170/5250
Maximum torque/speed (N·m/(r/min))	400/1750~4000
Maximum net torque/speed (N·m/(r/min))	380/1750~4000
Stable idling speed (r/min)	700±50
Emission level	China VI

## 7. Technical data

### Specifications and capacity of fuel/oil/fluid

Item	Specification	Capacity	
Fuel <sup>1)</sup>	95# or above high-quality unleaded gasoline	Total	65L
Engine coolant <sup>2)</sup>	DF-6, -35°C coolant	Total	10.2L
Engine oil:	Engine oil grade: SN and above Oil viscosity: SAE 5W-30.	Total <sup>3)</sup>	5.3L±0.1L
		Replace <sup>4)</sup>	4.5L
8AT transmission fluid	ATF AW-1	Total	6.6±0.1L
PTO gear oil	Castrol syntrax long life 75W-90	4WD model	0.45L
Rear differential & reducer gear oil	Castrol syntrax long life 75W-90	4WD model	0.45L
Torque transfer device fluid	OIL SL 12-301	Total	0.63±0.03L
Brake fluid	DOT4	Total	0.82L
Windshield washer fluid	44% methanol, and 56% water with hardness not more than 205 g/t	Total	3L
A/C refrigerant	R134a	Total	880±20g
Compressor oil	ND-OIL8	Total <sup>5)</sup>	5mL

- Note: 1) Long-term use of fuels with sulfur content higher than the standard value may result in excessive emissions. Please use fuels that comply with local standards for vehicles.
- 2) Including the coolant in the expansion tank and the residual coolant in the engine.
- 3) The oil capacity for overhaul of engine assembly.
- 4) Including the oil capacity for replacement of oil filter.
- 5) Compressor oil filling volume only for maintenance of A/C cooling system.

### 7.4 Specifications of transmission, chassis and bulb

#### Transmission parameters

Model	8AT*
Type	AT, 8 gears
Drive	2WD/4WD
Final ratio	3.329
1st gear	5.250
2nd gear	3.029
3rd gear	1.950
4th gear	1.457
5th gear	1.221
6th gear	1.000
7th gear	0.809
8th gear	0.673
Reverse gear	4.015

#### Suspension

Type	Front suspension	Rear suspension
	McPherson, independent	Multi-link independent suspension

#### Wheels

Specifications of rim	8J × 19*, 8J × 20*	
Tire specification	255/55R19*, 255/50R20*	
Tire pressure	Front wheel	Rear wheel
	240 kPa	240 kPa
Specifications of spare wheel rim	4J×18	
Specifications of spare tire	T155/85R18	
Pressure of spare tire	420 kPa	

Note: The standard tire pressure data label of the original tire of this vehicle is attached under the B pillar on the driver's side.

#### Steering gear

Type	Rack and pinion type electric power steering gear
Power steering type	Electric power steering

#### Brake

Type	X-type double circuit, hydraulic brake, vacuum booster
Front wheel	Disc brake
Rear wheel	Disc brake
Parking brake	Electric park brake (EPB)

## 7. Technical data

### Dynamic balance of wheels

Designation		Residue dynamic unbalance
Front wheel	Inner side	≤8g
	Outer side	≤8g
Rear wheel	Inner side	≤8g
	Outer side	≤8g

### Free travel of brake pedal

Designation	Parameters
Travel	108 mm
Free travel	≤8mm

### Technical parameters of brake linings

Designation	Parameters
Wear limit of front wheel brake lining (excluding the backplate of brake lining)	2 mm
Wear limit of rear wheel brake lining (excluding the backplate of brake lining)	2 mm

### Wheel alignment parameters

Designation		Parameters
Front wheel	Individual toe-in	5'±3'
	Wheel camber	-22'±30'
	Kingpin caster angle	6°34'±45'
	Kingpin inclination angle	13°41'±45'
Rear wheel	Individual toe-in	5'±3'
	Wheel camber	-1°2'±30'

### Battery

Model		SLI H6
Parameters	Rated voltage	12 V
	Capacity at 20 hr	75 Ah
	Low temperature start current (EN)	680CCA

### Lamps

Lamps	Model	Power
High beam	LED	/
Low beam	LED	/
Daytime running lamp*	LED	/
Front turn signal lamp*	LED	/
Front position lamp	LED	/
Rear fog lamp	LED	/
Side turn signal lamp	LED	/
Brake lamp	LED	/
Rear position lamp	LED	/
High-mounted stop lamp	LED	/
Rear turn signal lamp	LED	/
Reverse lamp	LED	/

Lamps	Model	Power
License plate lamp	LED	/
Front dome lamp	LED	/
Glove box lamp*	LED	/
Dome lamps of 2nd and 3rd rows	LED	/
Trunk lamp	LED	/
Cigarette lighter light	LED	/
Vanity mirror lamp	LED	/
Driver's footwell atmosphere lamp *	LED	/
Front passenger's footwell atmosphere lamp *	LED	/
Courtesy lamp *	LED	/
Smart ambient light*	LED	/

Replacing bulbs => [See page 265.](#)

## 7. Technical data

### Fuses in instrument panel PDU

The fuses may slightly vary from vehicle to vehicle. In this regard, the actual vehicle shall prevail.

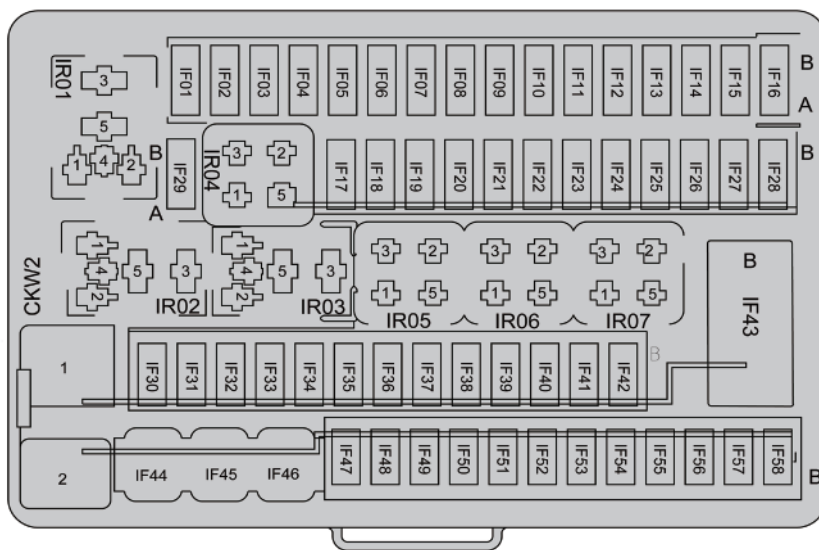

OMA60-0234



## 7. Technical data

No.	Rated value	Feature/component
IF01	20A	Cigarette lighter
IF02	7.5A	Integrated BCM/GWM
IF03	7.5A	ACU/DSM ECU *
IF04	7.5A	Rear USB port/mobile phone WCM */DVR USB port */2nd-row left seat (USB port) *
IF05	20A	Trunk 12V auxiliary power supply
IF06	—	—
IF07	7.5A	GWM/T-BOX ECU
IF08	—	—
IF09	20A	Left front seat connector (front seat controller) *
IF10	—	—
IF11	10A	GWM/HVAC control unit/left front seat connector (front seat controller) */mobile phone WCM *
IF12	15A	8AT TCU *
IF13	7.5A	Electronic anti-dazzling interior rearview mirror */defogger relay (ER07)/integrated BCM/rear blower relay (ER08)
IF14	20A	Integrated BCM
IF15	10A	Instrument cluster/HUD *
IF16	—	—
IF17	10A	SRS ECU
IF18	7.5A	ECM/8AT TCU

No.	Rated value	Feature/component
IF19	7.5A	T-BOX ECU/instrument cluster */GWM */integrated BCM
IF20	7.5A	4WD electronic control unit */brake switch
IF21	7.5A	ESPI
IF22	7.5A	EPS ECU/GSM/shift-by-wire actuator module/HVAC control unit
IF23	7.5A	RCP/left front seat connector (front seat controller) */panorama sunroof ECU */front dome lamp assembly
IF24	7.5A	3rd row right connector (3rd row seat controller) *
IF25	7.5A	ALS switch * lighting controller */front combination lamp 1 */rear combination lamp A1 */right front combination lamp (ALS motor) */left front combination lamp (ALS motor) */air quality sensor *
IF26	7.5A	ACU/HUD */RPA ECU */AVM ECU */APA ECU *
IF27	—	—
IF28	—	—
IF29	—	—
IF30	30A	4WD electronic control unit *
IF31	20A	Integrated BCM (door lock power supply)
IF32	10A	Lighting controller */RF receiver module/DSM ECU *

## 7. Technical data

No.	Rated value	Feature/component
IF33	20A	Integrated BCM (rear wiper power supply)
IF34	7.5A	RLS/right rear BSD ECU */left rear BSD ECU */APA ECU */AVM ECU */clock spring/GSM
IF35	7.5A	GWM
IF36	15A	Integrated BCM (turn signal lamp power supply)
IF37	30A	8AT TCU/integrated BCM/instrument cluster/ HUD *
IF38	10A	IAL */EPB switch/AV display/RCP
IF39	30A	3rd row right connector (3rd row seat controller) *
IF40	20A	Integrated BCM (main lighting power supply 1)
IF41	10A	OBD DLC/fuel filler cap lock motor/fuel filler cap lock relay (IR05)/OBD DLC 1
IF42	20A	Integrated BCM (main lighting power supply 2)
IF43	Dark current switch	Left front seat connector (memory seat module) */GWM/HVAC control unit/mobile phone WCM *
IF44	30A	PLGM
IF45	30A	Right front door control module
IF46	30A	Left front door control module
IF47	10A	Right rear combination lamp A1*
IF48	20A	ACU

No.	Rated value	Feature/component
IF49	20A	3rd row right connector (3rd row seat controller) *
IF50	10A	IG2 power supply
IF51	20A	Left front seat connector (front seat controller/ seat adjusting switch) *
IF52	20A	Right front seat connector (seat adjusting switch power supply) *
IF53	15A	Integrated BCM (windshield washer motor power supply)
IF54	30A	3rd row right connector (3rd row seat controller) *
IF55	20A	Panorama sunroof ECU *
IF56	20A	Panorama sunroof sunshade *
IF57	—	—
IF58	10A	Left rear combination lamp A1*
IR01	—	ACC relay
IR02	—	Lock-up relay 1
IR03	—	Lock-up relay 2
IR04	—	IG1 relay
IR05	—	Fuel filler cap lock relay
IR06	—	—
IR07	—	IG2 relay

## 7. Technical data

### Fuses in engine compartment PDU

The fuses may slightly vary from vehicle to vehicle. In this regard, the actual vehicle shall prevail.

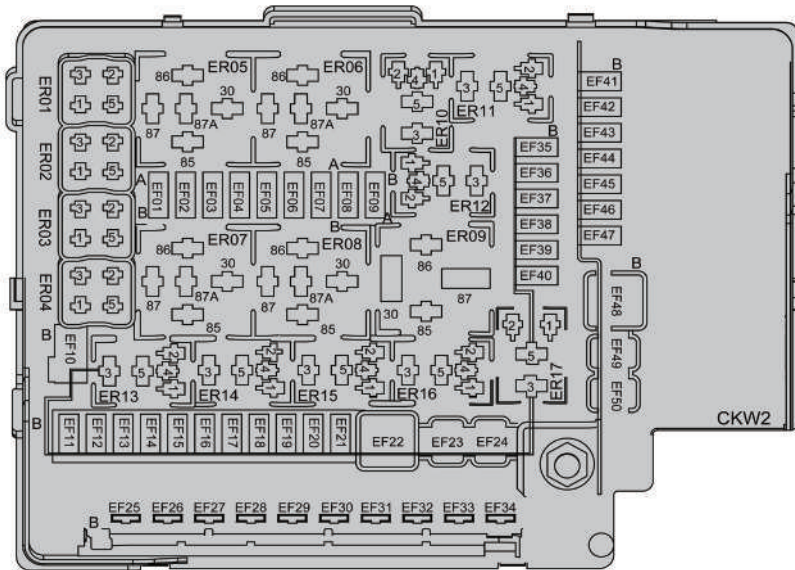

OMA60-0235

## 7. Technical data

No.	Rated value	Feature/component
EF01	—	—
EF02	—	—
EF03	—	—
EF04	7.5A	ECM
EF05	—	—
EF06	—	—
EF07	—	—
EF08	—	—
EF09	—	—
EF10	—	—
EF11	—	—
EF12	15A	Horn relay (ER03)/horn
EF13	—	—
EF14	7.5A	MRR module */LDW ECU *
EF15	30A	Shift-by-wire actuator module
EF16	20A	Main fuel pump
EF17	20A	Wiper/wiper speed control relay (ER11)/wiper relay (ER12)
EF18	7.5A	Brake switch
EF19	7.5A	Main relay (ER17)/ECM
EF20	30A	Shift-by-wire actuator module

No.	Rated value	Feature/component
EF21	30A	Amplifier module*
EF22	60A	To instrument panel PDU
EF23	40A	ESPI
EF24	30A	IG1 On
EF25	30A	Starter excitation coil
EF26	40A	ACC power supply
EF27	40A	Front blower
EF28	40A	Rear windshield defogger heater
EF29	50A	Front seat connector (front seat controller) */ GWM/T-BOX ECU/HVAC control unit/mobile phone WCM *
EF30	—	—
EF31	—	—
EF32	60A	To instrument panel PDU
EF33	—	—
EF34	—	—
EF35	10A	Cooling fan control module/fuel pump relay (ER14)
EF36	15A	Ignition coil 1/ignition coil 2/ignition coil 3/ignition coil 4
EF37	15A	ECM (main relay power supply)

## 7. Technical data

No.	Rated value	Feature/component
EF38	10A	Upstream oxygen sensor/downstream oxygen sensor/compressor relay (ER04)/starter relay 1 (ER15)/starter relay 2 (ER16)
EF39	10A	PCV heater relay (ER10)/PCV heater/canister vent valve/electronic intake air recirculation valve/canister solenoid valve/oil control valve (intake)/oil control valve (exhaust)/electronic thermostat
EF40	—	—
EF41	—	—
EF42	20A	Right front combination lamp 1 *
EF43	—	—
EF44	20A	Left front combination lamp 1 *
EF45	7.5A	A/C compressor/blower relay (ER05)
EF46	—	—
EF47	15A	2nd row right seat connector (slider motor switch power supply)
EF48	40A/60A	ESPI
EF49	—	—
EF50	40A	Rear blower
ER01	—	—
ER02	—	—
ER03	—	Horn relay

No.	Rated value	Feature/component
ER04	—	Compressor relay
ER05	—	Blower relay
ER06	—	—
ER07	—	Defogger relay
ER08	—	Rear blower relay
ER09	—	—
ER10	—	PCV heater relay
ER11	—	Wiper speed control relay
ER12	—	Wiper relay
ER13	—	—
ER14	—	Fuel pump relay
ER15	—	Starter relay 1
ER16	—	Starter relay 2
ER17	—	Main relay

## 8. Accident handling

### 8.1 Driver's tools and spare tire

#### Driver's tools

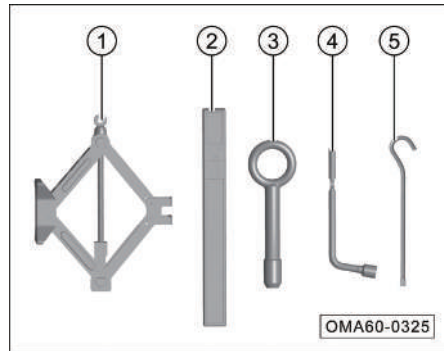

The following tools are provided in the trunk. After use, they shall be cleaned in time and placed back.

- ① Jack
- ② Warning triangle
- ③ Towing hook
- ④ Wheel bolt removal wrench
- ⑤ Special wrench for jack

#### First aid kit

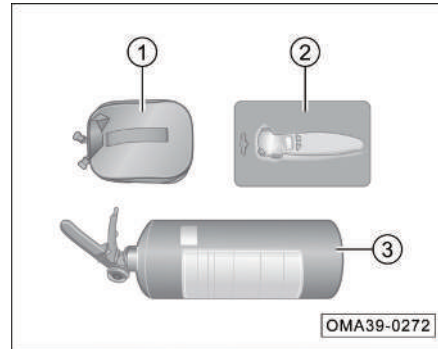

The first aid kit of this vehicle includes:

- ① Medical kit: The medical kit contains trauma emergency medical supplies (e.g. medical gauze package, medical adhesive tape, medical ventilated bandage, triangular bandage, iodine swabsticks, dressing tweezers, safety scissors) for stopping bleeding and dressing; for trauma emergency treatment.
- ② Tire pressure gauge: Used to measure tire pressure.
- ③ Portable dry powder fire extinguisher: Used for emergency fire extinguishing in case of fire in the vehicle.

#### Installing spare tire

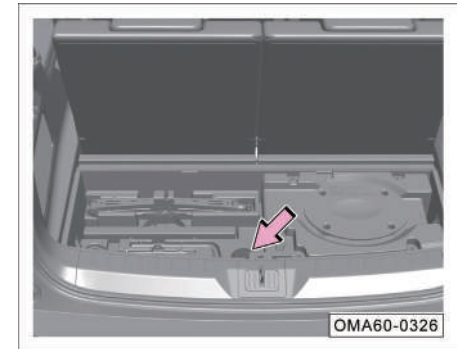

Remove the spare tire:

- Open the liftgate.
- Take out the trunk carpet.
- Pry open the trim cover.

## 8. Accident handling

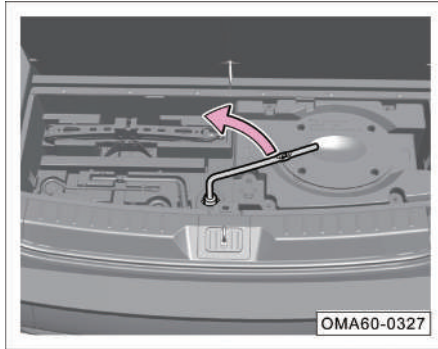

- Take out the wheel bolt removal wrench.
- Set the wheel bolt removal wrench firmly on a wheel bolt.
- Turn the wheel bolt removal wrench counterclockwise until it stops and the spare tire is fully lowered to the ground.

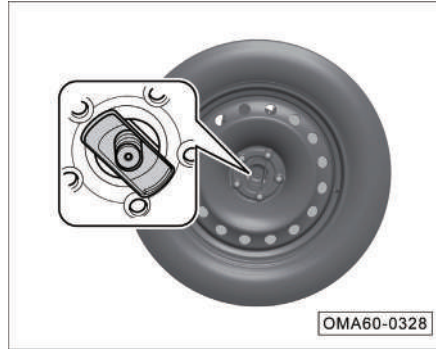

- Raise the spare tire and tilt it to release the spare tire lower fixing bracket.
- Take out the spare tire.
- Install it in the reverse order.

### WARNING

- A full-size tire must not be hung under the vehicle, and shall be stored and secured in the vehicle.
- If a full-size tire is hung under the vehicle, it will come into contact with the exhaust heat shield, which cannot effectively secure the tire and will cause irreversible damage to the tire.

### NOTE

The spare tire has been inflated. Check its pressure regularly to ensure that it is at the specified maximum tire pressure, and perform multiple inspections every year.

## 8. Accident handling



### WARNING

- The spare tire shall be used strictly in accordance with its use requirements to avoid danger.
- It is strictly prohibited to install and use more than 1 spare tire at the same time.
- It is forbidden to use spare tires that have been damaged or worn to the limit.
- The storage and service life of spare tires is 6 years. It is prohibited to use them beyond the time limit.
- After installing the spare tire, check the tire pressure as soon as possible to keep it within the specified range.
- The maximum speed of spare tires must not exceed 80 km/h, and sharp acceleration and emergency braking shall be avoided.

### 8.2 Use of warning triangle

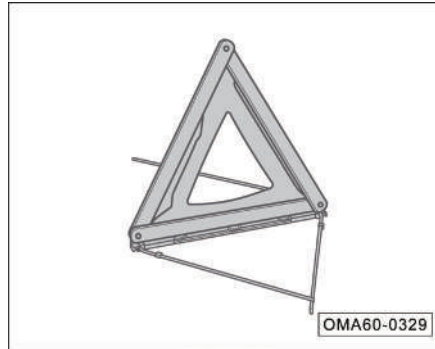

- Open the liftgate.
- Lift the trunk carpet.
- Take out the warning triangle and unfold it for use.

### Placement distance

Ordinary highway		Expressway
Daytime	Night	
≥50m	≥80m	≥150m



### CAUTION

The data above is for reference only. Please place the warning triangle at the distance specified by traffic regulations.



### 8.3 Use of reflective vest

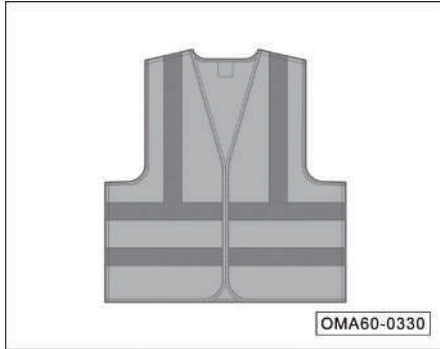

- If it is necessary to stop the vehicle due to an accident or other failures, take out the reflective vest from the glove box to put on it well before getting off the vehicle for checking and troubleshooting.

#### **i** NOTE

- While handling vehicle accidents, be sure to wear a reflective vest as required to attract the attention of passersby or other drivers regardless of the lighting conditions.
- After using the reflective vest, please store it in the glove box properly. If necessary, clean it according to the indication on the collar mark to maintain the reflective performance.

### 8.4 Replacing flat tires

#### Preparations

- Apply the parking brake.
- Set the gearshift lever to “P” position.
- Turn the vehicle power switch to the “OFF” position, and turn on the hazard warning lamp.
- Place a warning triangle in a suitable position behind the vehicle.
- Find a suitable object to wedge the wheel in the diagonal position of the one to be replaced to prevent the vehicle from moving.
- Take out the driver's tools and the spare tire.

#### **⚠** WARNING

- **Relevant regulations must be strictly followed.**
- **All occupants must leave the vehicle and wait in a safe place.**

## 8. Accident handling

### Unscrewing the wheel bolts

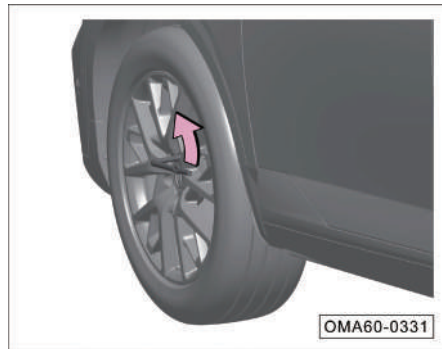

Set the wheel bolt removal wrench firmly on a wheel bolt, and unscrew the wheel bolt counterclockwise.

#### CAUTION

Loosen the wheel bolts just one turn before lifting the vehicle. After lifting the car, unscrew the wheel bolts completely, and then remove the flat tire.

### Lifting the vehicle

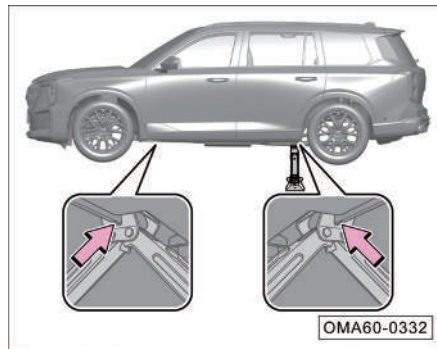

- Place the jack directly under the spine closest to the flat tire.
- Extend the jack high to ensure that the groove of the jack can engage with the spine.
- Check whether the jack is stable and tightly attached to the ground.

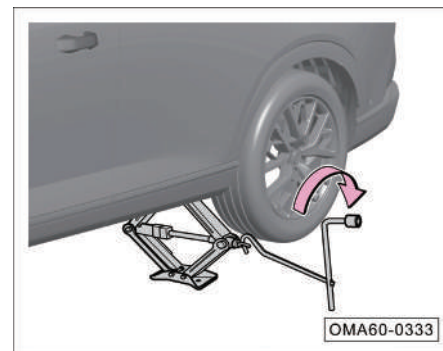

- Assemble the wheel bolt removal wrench, the special wrench for jack and the jack.
- Extend the jack clockwise to lift the vehicle and lift the tire off the ground.

## 8. Accident handling

### WARNING

Improper use of jacks will cause serious injury.

- The jack must be used on a hard and flat ground, and a hard pad (height not more than 1 cm) can also be placed under the jack as needed.
- Strictly observe the precautions for jack operation.
- If a trailer is connected to the vehicle, the trailer must be separated from the vehicle.
- Observe the status of the vehicle continuously during the lifting. If the vehicle body is noticeably tilted, stop the lifting, identify the problem, and then lift the vehicle after solving the problem.

### WARNING

- The jack on the vehicle can only be used to lift the vehicle rather than other heavy objects or vehicles.
- While using the jack, do not start the engine; otherwise an accident may occur.
- When lifting the vehicle with a jack, remember not to place any part of your body under the vehicle to avoid accidents.
- If it is required to work under the vehicle, be sure to place a suitable protective support under the vehicle.

#### Removing the flat tire

- With the vehicle lifted up, use a wheel bolt removal wrench to screw off the loosened wheel bolts.
- Remove the flat tire.

#### Installing spare tire

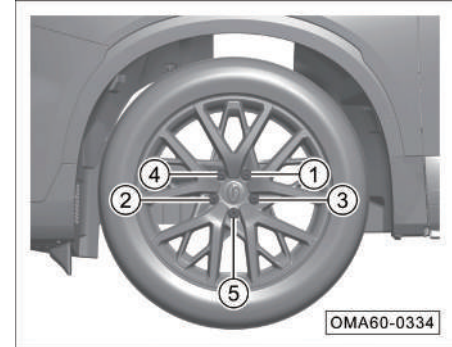

- Install the spare tire to the vehicle.
- Install all the wheel bolts, and pre-tighten them using the wheel bolt removal wrench in the order of ①~⑤ as shown.
- Give a verbal alert to confirm that nobody is around the vehicle, and then rotate the jack wrench counterclockwise to lower the vehicle.
- Tighten all wheel bolts using the wheel bolt removal wrench.

## 8. Accident handling

- In order to avoid the noise of the vehicle during driving later on, please remember the locations of various tools, put them back in place after use and fix them.

### CAUTION

After installing the wheel, please go to the GAC Motor authorized shop in time to check the tightening torque of the wheel bolts ( $125 \pm 15\text{N}\cdot\text{m}$ ). Otherwise, the bolts may be loose while the vehicle is running, easily causing traffic accidents.

### WARNING

- **The thread on the wheel bolt and the hub must be kept clean and free from adherent matters such as grease so that the bolt is easy to tighten.**
- **For replacement of a tire, if the bolts are rusted or difficult to be tightened, they must be replaced and the thread hole cleaned.**
- **When the spare tire is not in use, it must be securely fixed in the place where the spare tire is mounted.**

## 8.5 Microwave window



- The microwave window is set on the right of the front windshield corresponding to the interior rearview mirror.

### i NOTE

The microwave window can be used for installation of ETC card.

### 8.6 Fuse

#### Instrument panel PDU



- Open the cab lower protective plate storage box and pull it out to see the fuse in the instrument panel PDU (as shown in dashed shaded area).

#### Engine compartment power distribution unit (PDU)

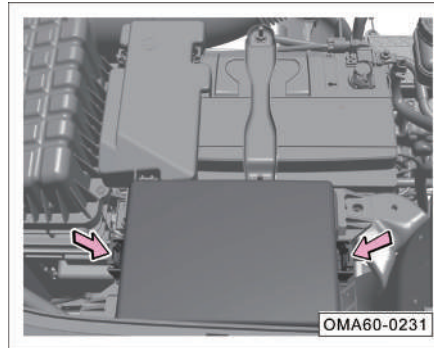

- Open the engine hood.
- Press the fixing clip in the direction of arrow to release the cover of the PDU.
- The fuse above the engine compartment PDU is exposed when the cover of the PDU is removed.

#### WARNING

**Never clean the engine compartment fuse box with a high-pressure water gun.**

#### Replacing fuse

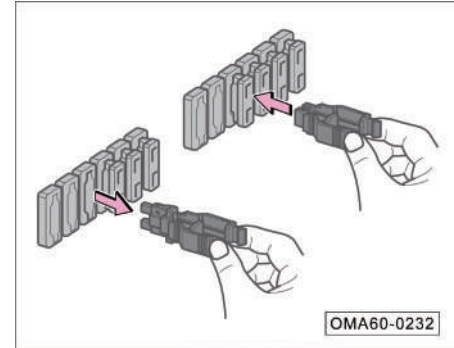

- Remove or install the fuse using the fuse puller in the engine compartment PDU.

## 8. Accident handling

### Blown fuse

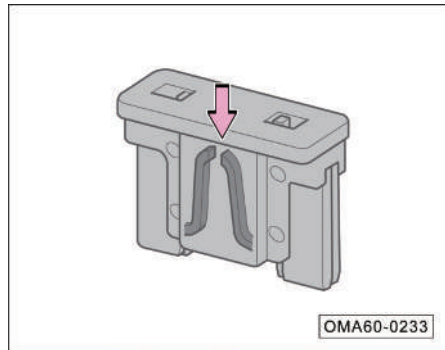

- If the fuse is blown (as arrowed), it is recommended to replace it with a new fuse of the same color and identification in a GAC Motor authorized shop.

#### **i** NOTE

Some electrical consumers may be equipped with multiple fuses each, or multiple electrical consumers may share a single fuse.

#### **👁** CAUTION

- All electrical consumers must be turned off before replacement of fuses.
- If it is required to replace the fuse, please consult the GAC Motor authorized shop.

#### **⚠** WARNING

- Fuses must not be reused.
- Do not use a fuse with rated current higher than the specified value; otherwise other components of the electrical system will be damaged.
- Using an inappropriate or repaired fuse will cause a short circuit or even a fire.
- The color and logo of the replaced fuse must be exactly the same as the original one.
- Never replace a fuse with metal sheets, clips, etc.
- The PDU must be kept clean inside. Pay attention to protection against moisture.

### 8.7 Emergency start

#### Jumper cable

If the engine cannot be started due to low battery power, it can be started by connecting this battery to the battery of another vehicle with jumper cables.

#### WARNING

- The engine compartment is a high-risk area. Improper operation can easily cause casualties.
- Before starting work on the battery, be sure to carefully read and follow the warning instructions for safety related to battery operation.

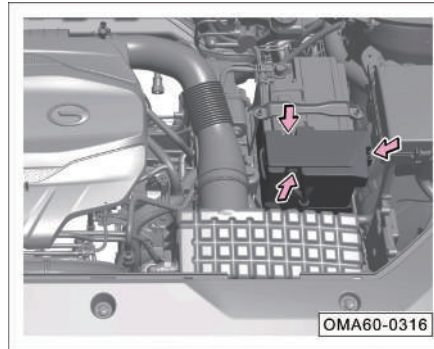

1. Turn off all electrical consumers (such as A/C and AV system).
2. Open the engine hood, remove the rear upper guard plate of engine compartment, and press the fixing clip as arrowed to remove the fuse box cover above the battery.

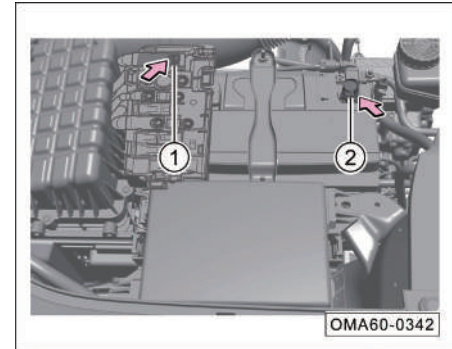

3. Connect the clamp of the red positive jumper cable to the battery positive ① of the vehicle, and connect the clamp on the other end to the battery positive of another vehicle; connect the clamp of the black negative jumper cable to the battery negative ② of the vehicle, and connect the clamp on other end to the engine block of another vehicle or a metal part firmly connected to the engine block of another vehicle.
4. Start the engine of the vehicle with power battery and let it idle. Then, start the engine of the vehicle with the depleted battery till the engine runs smoothly.
5. After the engine runs smoothly, remove the jumper cables in the reverse order.

## 8. Accident handling

### CAUTION

- While connecting the batteries of two vehicles, be sure to first connect the positive terminal and then the negative terminal.
- Properly place the jumper cable to avoid contact between the cable and the moving parts of the engine.

### WARNING

- **Be sure to turn off the headlamps before removing the jumper cables.**
- **Turn on the blower and rear windshield heater of the vehicle with the depleted battery to reduce the voltage peak generated when the cable are being removed.**
- **Remove the jumper cables with the engine running in the reverse order.**

### WARNING

The jumper cable should be properly connected to the positive and negative terminals instead of other positions of the battery as mentioned above, otherwise it may cause blown fuse or failure of some vehicle functions, and GAC will not assume any responsibility for such damage.

### WARNING

Improper use of jumper cables may cause battery explosion and serious injury.

- The voltage of the power battery must be the same as that of the depleted battery, and the capacities of the two batteries shall also be the same. Otherwise, it may cause an explosion.
- Never expose the battery to an open flame, for fear of an explosion.
- Never connect the negative cable directly to the negative terminal of a depleted battery. There shall be no static electricity near the battery. Otherwise, the combustible gas produced by the battery may be ignited by sparks, causing an explosion accident.
- Never connect the negative cable to a fuel system component or a brake line. Never lean over the battery during operation. Be careful not to get burned by acid.



### 8.8 Vehicle towing

If the vehicle needs to be towed, it shall be towed by the GAC Motor authorized shop or a professional towing company.

It is recommended to use a rollback tow truck for towing. If the conditions can not be met, a wheel-lift truck can also be used for towing the vehicle as appropriate.

#### Being towed by a rollback tow truck

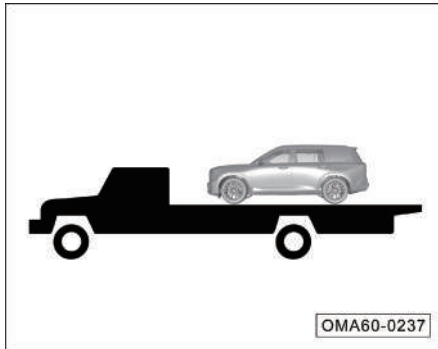

#### Being towed by a wheel-lift truck from the front

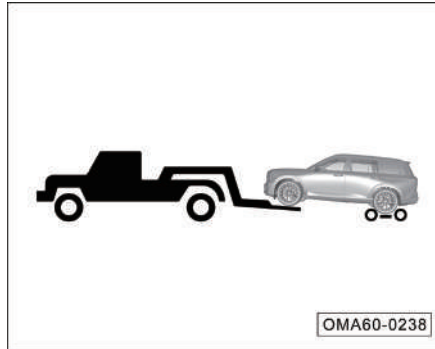

- Place a dolly under the rear wheels.

#### Being towed by a wheel-lift truck from the rear

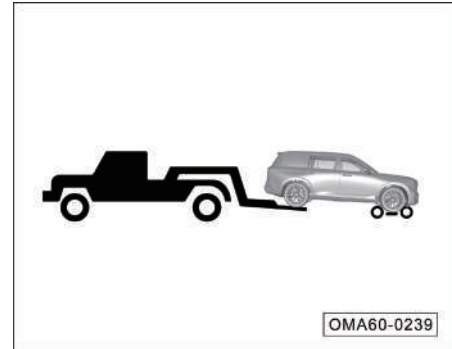

- Place a dolly under the front wheels.

## 8. Accident handling

### Emergency towing

If it is impossible to find a tow truck in an emergency, fasten the towing cable or towing chain in the emergency towing ring to temporarily tow the vehicle. However, this method is only suitable for low speed and short distance towing on a solid and flat road.

#### WARNING

**In emergency towing, drive slowly to avoid violent operation. Excessive towing force will damage the vehicle**

### Installing a towing hook

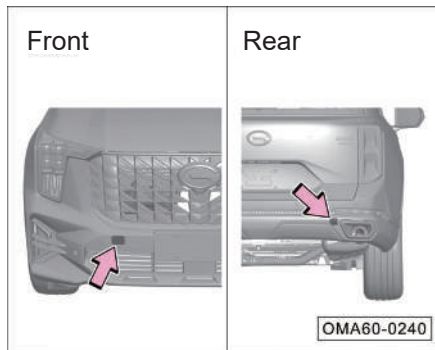

- Pry off the towing hook cover in the arrowed position using a slotted screwdriver wrapped with a cloth.

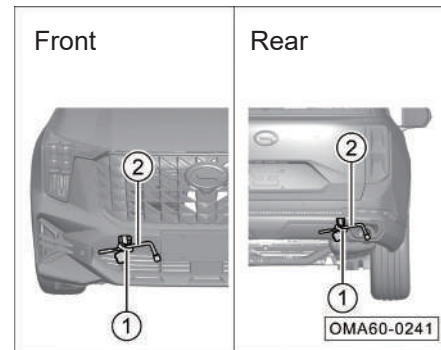

- Take out the towing hook ① and wheel bolt removal wrench ② from the tool kit in the trunk.
- Screw the towing hook ① clockwise into the thread hole.
- Insert the wheel bolt removal wrench ② into the round opening of the towing hook, and turn the wheel bolt removal wrench clockwise to make the towing hook be firmly screwed into the thread hole.

### Precautions for towing

Before emergency towing, be sure to follow the instructions below:

- Hazard warning lamps of both towing and towed vehicles must be turned on, and local traffic regulations must be complied with.
- The towing hook must be firmly tightened in the thread hole. Otherwise, the towing hook may slip out of the thread hole during towing.
- The towed vehicle must be shifted into "N".
- For the towed vehicle, set the vehicle power switch to the "ON" position and turn the steering wheel back and forth to confirm that the steering wheel can be turned.

During the emergency towing, be sure to follow the instructions below:

- Start the engine and drive at a slow speed till the towing rope is tight and then accelerate the vehicle slowly.
- Be sure to drive steadily and avoid sharp acceleration, sharp deceleration or abrupt turning.
- During towing, the towed vehicle shall be braked earlier than in normal conditions with the brake pedal lightly depressed.
- During towing, the towing rope must always be in a tight state.

### 8.9 Getting out of a trap

If the vehicle is stuck on a soft road such as sandy, muddy or snowy road, follow the steps below to get out of a trap:

1. Observe the areas in front of and behind the vehicle to ensure that there are no obstacles.
2. Turn the steering wheel to the left and to the right to grind areas around the front wheels to remove mud, snow or sand trapped around the tires.
3. Place wooden blocks, stones or other materials to help increase tire friction.
4. Start the engine and accelerate the vehicle slowly to get the vehicle out of the trap.
5. If the vehicle still cannot get out of the trap after attempts for several times, it is required to have a tow truck for rescue.

#### **i** NOTE

In the acceleration process, human assistance can be provided to push the vehicle from the front and rear for driving the vehicle out of the trap.

**This manual describes related information of entire GAC Motor series, including their configuration, functions, performance parameters and product schematic diagrams. Its content is valid when allowed to be printed. However, the actual configuration and function of the vehicles are subject to the specific vehicles delivered. If there is any difference between the schematic diagrams and the specific vehicle delivered, the actual vehicle shall prevail.**

**GAC Motor (Hangzhou) Co., Ltd. reserves the right to change, supplement or terminate the contents and technical specifications in this manual without prior notice.**

**GAC Motor Co., Ltd. owns the copyright of this manual. Without the written consent of GAC Motor Co., Ltd., it is not allowed to photocopy or extract the contents of this manual.**

**GAC Motor Co., Ltd.**