Thank you for choosing SAIC MAXUS Automotive Co.,Ltd. May our products and services bring fresh joy to your life!

Please take time to read and understand this Handbook and other publications supplied with it. Thus you can familiarize yourself with the vehicle and enjoy a driving experience with comfort, safety as well as economy.

This Driver's Handbook will provide you with the information necessary for getting familiar with your vehicle, including how to drive the vehicle, how to carry out routine maintenance checks, and what to do in an emergency.

This Handbook contains the latest information upon the time of printing and all modifications, interpretations and explanations should be reserved by the company. Based on the consideration that the products will be upgraded or in any other way(s) modified constantly, the company reserves the right to apply these changes mentioned here before without notice when the Handbook has been hereby printed and published and will accept no liability.

This Handbook is an indispensable part of the vehicle. If you want to sell the vehicle, please remember to provide the new owner with this Handbook.

Special Announcement

Driver's Handbook and Warranty & Service Handbook specify the agreement between the company and the user on establishment and termination of rights and obligations concerning the quality warranty and after-sales service of product. Please be sure to read the Driver's Handbook and Warranty & Service Handbook carefully before using the product. If any damage is caused by misuse, neglect, incorrect operation or unauthorized refit, the user will have no right of claim, and any warranty request will be refused by SAIC MAXUS Automotive Co.,Ltd Service Dealer(hereinafter referred to as "Service Dealer").

Unauthorized re-production of this Handbook, whether electrically, physically or in any other way, and/or storing the Handbook in any inquiry system of any form or type shall not be permitted.

Wish you a pleasant driving!

SAIC MAXUS Automotive Co.,Ltd. Address: #2500, Jun Gong Road, Yang Pu District, Shanghai Postcode: 200438

SAIC MAXUS Automotive Co.,Ltd reserves the final right to interpret this Handbook

Contents

Perface	1	Front passenger seat adjustment.....	26
Manual Introduction	1	2nd row seats adjustment.....	26
About this manual.....	1	3rd row seats adjustment.....	30
Prompt information.....	1	Seat middle armrest adjustment.....	31
Precautions	3	Head restraints.....	32
Hazardous materials.....	3	Occupant Protection Device	33
Child/Animal.....	3	Properly seated.....	33
Personal safety.....	3	Seat belt.....	33
Vehicle Identification	4	Seat belt pretensioner.....	40
Vehicle Identification Number (VIN).....	4	Airbag.....	40
Engine number.....	4	Child restraints (not available with the vehicle).....	43
Vehicle plate.....	5	Instruments and Controls	48
1 Before You Drive	7	Instrument Cluster	49
Keys	8	Speedometer.....	50
Ordinary key.....	8	Tachometer.....	50
Remote key.....	8	Fuel gauge.....	50
Extension/Retraction of mechanical key portion.....	9	Engine coolant temperature gauge.....	50
Replace battery in remote key.....	10	Information Center	51
Doors and Locks	12	Information center type I.....	51
Preventing the vehicle from theft.....	12	Information center type II.....	53
Central lock system.....	12	Alarm messages.....	55
Manual tailgate.....	15	Fatigue driving detection and reminder.....	56
Power tailgate.....	16	Tire pressure monitoring system.....	57
Child safety door lock.....	19	Warning Lamps and Indicators	58
Windows	20	Direction Indicator.....	58
Power window.....	20	Front Fog Lamp Indicator.....	58
Power sunroof.....	22	Headlamp High Beam Indicator.....	58
Seats	23	Rear Fog Lamp Indicator.....	58
Driver seat adjustment.....	23	Position Lamp Indicator.....	58
		AFS (Adaptive Front Lighting System) Warning Lamp.....	58

Contents

Airbag Warning Lamp.....	58	ECO Indicator Lamp.....	66
Driver and Front Passenger Seat Belt Warning Lamp.....	59	SPORT Indicator Lamp.....	66
Rear Seat Belt Warning Lamp.....	59	Fuel Filter Water Level Warning Lamp.....	66
Brake System Warning Lamp.....	59	Glow Plug Indicator.....	66
ABS (Anti-lock Brake System) Warning Lamp.....	60	DPF (Diesel Particulate Filter) Warning Lamp.....	67
EBD (Electronic Brake Force Distribution) Warning Lamp.....	60	Instrument Panel Switch.....	67
ESP (Electronic Stability Program) Indicator Lamp.....	60	Instrument panel illumination control switch.....	67
ESP (Electronic Stability Program) OFF Indicator Lamp.....	60	Headlamp leveling switch.....	68
Hill Descent Indicator Lamp.....	61	Adaptive front-lighting System.....	68
Engine Malfunction Warning Lamp.....	61	Hazard warning lamp switch.....	69
Emission MIL.....	61	Floor Console Switches.....	69
Oil Pressure Warning Lamp.....	61	Switch group in left front side of the shift lever.....	69
Engine Immobiliser Warning Lamp.....	61	Switch group in left rear side of the shift lever.....	70
Body Theft Deterrent Warning Lamp.....	62	Switch group in right side of the shift lever.....	72
Tire Pressure Monitoring System Warning Lamp.....	62	Switches on Steering Column and Steering Wheel.....	74
Battery Charging Indicator Lamp.....	62	Ignition switch and steering lock.....	74
Constant Speed Cruise Indicator Lamp.....	62	Combination lamp control & direction indicator lamp stalk switch.....	75
Adaptive Cruise Control Indicator Lamp.....	62	Wiper & washer stalk switch.....	77
Adaptive Cruise Vehicle-to-Vehicle Distance Indicator Lamp.....	63	Instrument cluster selection and cruise switch.....	79
4WD Malfunction Warning Lamp.....	63	Voice control, Bluetooth phone, steering wheel heating and customized switch.....	81
Lane Departure Alert Warning Lamp.....	63	Steering Wheel Adjustment.....	82
Intelligent Start/Stop System Indicator Lamp.....	63	Horn.....	82
AUTO HOLD Indicator Lamp.....	64	Heating, Ventilation and Air Conditioning.....	83
Electronic Parking Brake (EPB) Indicator Lamp.....	64	Front vents.....	83
Electronic Parking Brake (EPB) Malfunction Indicator Lamp.....	65	Rear vent.....	84
Electric Power Steering (EPS) System Failure Warning Lamp.....	65	Automatic A/C front control panel.....	85
Front Collision Warning (FCW)/Automatic Emergency Braking (AEB) Warning Lamp.....	65	Electronic A/C front control panel.....	89
Ahead Vehicle Indicator Lamp.....	65	Automatic A/C rear control panel.....	91
Electronic Differential Lock Indicator Lamp.....	65	Electronic A/C rear control panel.....	93
Traffic Signs Warning Lamp.....	66		

Contents

Recommendation for A/C operation	94	MP5+Radio (Type 2)	121
Rearview Mirrors	94	Common troubleshooting	122
Exterior Rearview Mirrors	94	2 Starting and Driving	125
Interior rearview mirror	96	Before Starting and Driving	126
Interior Devices	97	Ignition Switch	126
Ceiling reading lamps	97	Key start	126
On-board inverter	98	Keyless start	127
USB port.....	99	Keyless Start System	129
12V power outlet	100	Keyless unlocking.....	129
Cigar lighter	101	Keyless locking.....	129
Ashtray	101	Keyless start.....	129
Cup holder.....	102	Backup starting.....	130
Storage box	103	Emergency flameout	130
Glove box	104	Engine Immobilizer System	131
Sun visor and vanity mirror.....	104	Keys	131
Glasses box.....	105	Enable/disable.....	131
Fire extinguisher.....	105	Start/Stop the Engine	132
Vehicle tools	107	Starting	132
MP3+Radio	108	Warm-up.....	133
Panel features description	108	Self-protection mode	133
Audio adjustment.....	109	Shutdown	133
Radio reception	110	Intelligent Start/Stop System	133
Playing in USB mode	111	Basic conditions of usage.....	133
Bluetooth	113	Shutdown and startup of engine.....	134
AUX IN interface	116	Instructions	135
Volume during reversing.....	116	Driving	136
Common troubleshooting	117	"Running-in" of new vehicle.....	136
MP5+Radio	119	Driving	137
Precautions before use	119	Catalytic converter	138
MP5+Radio (Type 1)	120		

Contents

DPF (Diesel Particulate Filter).....	139	EPB (Electronic Parking Brake).....	172
Fuel.....	142	AUTO HOLD.....	175
Fuel filler cap.....	142	Warning lamp.....	176
Refueling.....	143	Constant Speed Cruise Control System.....	176
Gasoline detergent.....	144	Set cruise control.....	177
Save fuel.....	144	Terminate the cruise control.....	179
Precautions for cold weather.....	145	Clear speed memory.....	179
Manual Transmission.....	146	Parking Assist System.....	179
Gear Shift.....	146	Reverse radar sensors.....	179
6AT Automatic Transmission.....	147	Front and rear radar sensors.....	180
Operation.....	147	Reverse cameras.....	182
Gears.....	148	360° Around-view system.....	183
Manually release P gear lock.....	149	Intelligent Semi-Automatic parking assist system.....	184
8AT Automatic Transmission.....	149	Driver Assist System.....	186
Gear.....	149	Adaptive Cruise Control (ACC).....	191
Auto park function.....	156	FCW and AEB.....	199
Manual release of P gear lock (Towing mode).....	157	Lane Keeping Assist (LKA).....	205
Electric Power Steering Device.....	158	Traffic Sign Recognition (TSR).....	208
Four Wheel Drive System (4WD).....	159	Blind Spot Detection (BSD).....	209
Part-Time 4WD System.....	159	Lane Change Assistance (LCA).....	211
Real-Time 4WD System.....	161	Rear Cross Traffic Alert (RCTA).....	212
All-Terrain Four Wheel Drive System (ATS).....	163	Door Opening Warning (DOW).....	213
Electronic Differential Lock.....	166	Tires.....	214
Precautions before EDL use.....	166	Winter tires.....	215
EDL use instruction.....	166	Tire chain.....	216
Brake System.....	167	Loading.....	216
Service brake.....	167	Luggage compartment.....	217
ABS (Anti-lock brake system).....	168	Roof rack and load carrier.....	220
ESP (Electronic Stability Program).....	170	3 Emergency Troubleshooting.....	221

Contents

Hazard Warning Lamps	222	Gasoline engine vehicles	244
Warning Triangle	222	Diesel engine vehicles.....	245
Wheel Replacement	223	Engine Hood	246
Jack	223	Open the engine hood.....	246
Spare wheel	223	Close the engine hood	246
Wheel replacement	225	Engine Oil	247
Vehicle Towing	228	Check and refill.....	247
Towing eye	228	Engine oil consumption	249
Towing	230	Coolant	249
Fuel Filter Water Drain	230	Check and refill.....	250
Jump Start	231	Brake Fluid	251
Battery disconnection	231	Check and refill.....	251
Jump start.....	232	Washer Fluid	252
Fuse Replacement	233	Check and refill.....	252
Driver compartment fuse box	233	Washer Nozzles	252
Front compartment fuse box	235	Adjust and clean	252
Fuse replacement.....	238	Wiper Blade	253
Bulb Replacement	239	Check	253
Bulb specification	239	Replacement	253
Bulb replacement	240	Maintenance.....	253
4 Maintenance and Service	241	Seat Belt	254
Safety	242	Check	254
Regular Maintenance	243	Maintenance.....	254
Owner Checks	243	Battery	255
Daily check	243	Car parking period.....	256
Weekly check or check before a long trip.....	244	Winter operation	256
Severe working conditions	244	Battery charge with ground equipment.....	256
Front Compartment	244	Battery removal	257
		Battery replacement	258

Contents

Battery installation	258
Tires	258
Tire pressures	258
Wear indicators	259
Tire check and rotation	260
Other Maintenance	261
Vehicle wash	261
Engine carbon deposit cleaning	261
Underbody corrosion protection	262
Seat and interior trim	262
Door seals	262
Windows	262
5 General Technical Parameters	263
Main Vehicle Dimension Parameters	264
Complete Vehicle Mass Parameters	265
Complete Vehicle Performance Parameters	267
Main Engine Parameters	268
Chassis Technical Parameters	269
Recommended Fluids	270
Wheels and Tires	272
Wheel Alignment Parameters	273

Preface

Manual Introduction

About this manual

This manual applies to D90 series Passenger car.

Caution
The information covered by this manual does not aim to certain model and variant, thus some contents in this manual may be inapplicable to your model.

This vehicle product follows enterprise standard Q31/0110000019C040.

The figures in the manual are schematics, for your reference only.

Prompt information

Warning



This sign means that you must abide by relevant steps strictly and accurately in order to avoid causing personal injuries to yourself and other persons.

Caution

Caution
This sign means you must abide by relevant steps to avoid damaging your vehicle.

Preface

Note

Note: *This is suggestive description which is useful for you.*

Environmental protection



Everyone is obliged to protect the environment.

This symbol intends to remind you to pay attention to environmental protection.

Arrows



It indicates the described object.



It indicates the moving direction of an object.

Please refer to

The content referred. It indicates the name of "Section".

Precautions

Hazardous materials

 Most liquids and some substances used on a motor vehicle are toxic. It is strictly prohibited to drink them, and keep injuries away from them as far as possible. Battery acid, coolant, brake fluid, power steering fluid, fuel, cleaning solution, lubricant, refrigerant and other liquids and various adhesives contain these toxic substances. Be sure to carefully read and strictly follow the instructions printed or stamped on parts. This kind of instructions are shown for the sake of your health and personal safety. Please treat them with caution.

For your safety, please read this manual carefully.

Child/Animal

 An accident and personal injury may be caused if any unsupervised child or animal operates the control devices and switches installed on the vehicle or contacts any equipment or objects transported by the vehicle.

In order to prevent the accident or personal injury caused by a child or animal, do not leave the child or animal in the vehicle without adult supervision. In hot days, the child or animal left in the vehicle may suffocate.

Personal safety

 Each seat on your vehicle is equipped with a seat belt to lower the possibility of personal injury in case of an accident. All occupants are required to wear seat belts. In addition, your vehicle has been installed with supplementary restraint system (SRS) comprising an airbag and a seat belt pre-tensioner, providing extra protection for the driver and front passenger.

Please refer to "Supplementary Restraint System (SRS)" in the Before You Drive section. The misoperation of airbag may lead to personal injuries.

Preface

Vehicle Identification

When you contact our Service Dealer, you shall provide the vehicle identification number (VIN).

The engine number may also be required if the engine is involved during communication.

Vehicle Identification Number (VIN)

VINs on the vehicle:

- On the right front longitudinal beam of vehicle (seal position).
- On the vehicle identification plate located on the door frame of left front door.
- On the instrument panel at the right lower corner of windshield, visible through the right lower corner of windshield.

This vehicle is equipped with an OBD data link connector, located under the instrument cluster. You can contact our Service Dealer to read VIN information from the electronic control unit with the special equipment.

Engine number

Gasoline engine vehicles: Engine number is printed on the rear side of engine exhaust side cylinder.

Diesel engine vehicles: Engine number is printed on the front of engine cylinder.

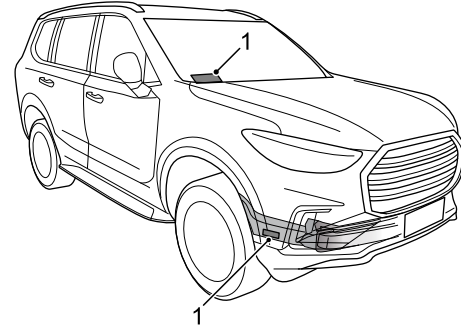

1 Vehicle Identification Number (VIN)

Preface

Vehicle plate

Information contained on the vehicle plate

- Vehicle identification number
- Type
- Engine Model
- MNEP(Maximum net engine power)
- Engine displacement
- GVW
- Seat No.
- Built Date
- Manufacturer
- Manufacturing country

Location of vehicle identification plate

The vehicle identification plate (1) is located on the door frame of front door.

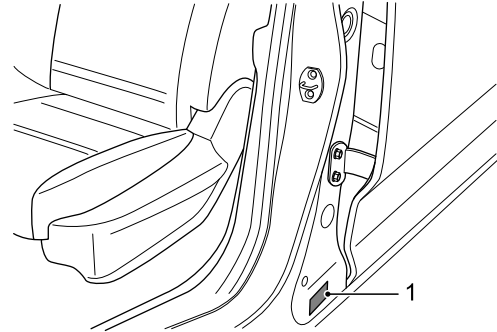

Before You Drive

- 8 Keys
 - 12 Doors and Locks
 - 20 Windows
 - 23 Seats
 - 33 Occupant Protection Device
 - 48 Instruments and Controls
 - 49 Instrument Cluster
 - 51 Information Center
 - 58 Warning Lamps and Indicators
 - 67 Instrument Panel Switch
 - 69 Floor Console Switches
 - 74 Switches on Steering Column
and Steering Wheel
 - 82 Steering Wheel Adjustment
 - 82 Horn
 - 83 Heating, Ventilation and Air
Conditioning
 - 94 Rearview Mirrors
 - 97 Interior Devices
 - 108 MP3+Radio
 - 119 MP5+Radio
-

Before You Drive

Keys

The vehicle is equipped with 1 ordinary key and 1 remote key, or 2 remote keys or 2 remote keys with passive entry & passive start system (hereinafter referred to as PEPS).

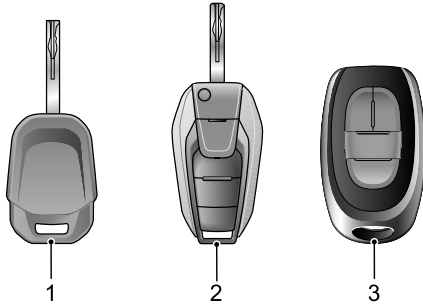

- 1 Ordinary key
- 2 Remote key
- 3 Remote key with PEPS

Note: *If a key is lost, you must provide the key number on the metal or plastic plate attached with the key, and our Service Dealer will provide the replacement. To ensure safety, you are recommended to keep the metal or plastic plate attached with key properly. For the sake of safety, the key has been electronically coded with the engine immobilizer system and can be used with the system in the matching way only. Special procedures shall be followed*

to manufacture a same key with the lost one. Any uncoded key cannot start the engine but can lock/unlock doors.

Ordinary key

The ordinary key is mainly used for activating the engine immobilizer system and starting the system and also can be used for locking/unlocking the driver door. Please refer to "Doors and Locks" as well as "Switches on Steering Column and Steering Wheel" in this section for more details about the ordinary key.

Remote key

Remote key is a control component of automobile central locking system. It can be used for locking/unlocking all doors.

Note: *The remote key/keys have been electronically coded with the locking/unlocking system and can be used with the system in the matching way only. Special procedures shall be followed to manufacture a same remote key with the lost one. All Service Dealer are ready to provide assistance for you. Please refer to "Central Locking System" in this section for more details about the remote key.*

Caution

The engine immobilizer system can accept 8 coded keys at most (including ordinary keys and remote keys). The engine immobilizer system can accept 4 coded keys at most (for remote keys with PEPS function).

Before You Drive

Extension/Retraction of mechanical key portion

Mechanical key portion of remote key can be extended or retracted, hereinafter referred to as mechanical key portion.

Mechanical key portion

Press the release button on the remote key, and the mechanical key portion will extend from the key body.

To retract the mechanical key portion, directly insert it into the body of remote key with PEPS and close the rear trim panel.

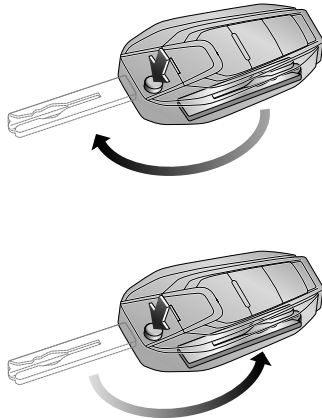

Mechanical key portion of a remote key with PEPS

Press the release button on the remote key with PEPS, remove the rear trim panel and pull the mechanical key portion from the key body.

To retract the mechanical key portion, directly insert it into the body of remote key with PEPS and close the rear trim panel.

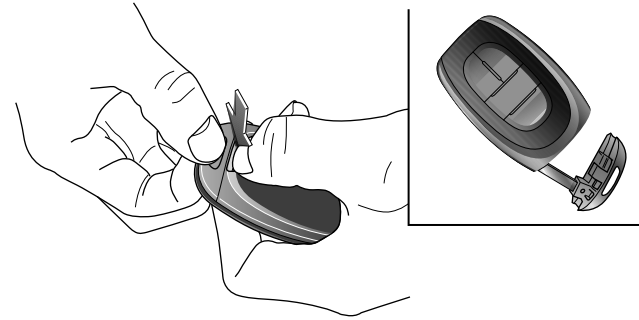

Before You Drive

Replace battery in remote key

! Key battery has the risks of fire, explosion and combustion. Do not charge the battery. The used battery shall be disposed in a proper way. Keep the battery in the place out of reach by children.

! **WARNING:** Do not ingest the battery, chemical Burn Hazard.

This product contains coin/button cell battery. If the coin/button cell battery is swallowed, it can cause severe internal burns in just 2 hours and can lead to death. Keep new and used batteries away from children. If the battery compartment does not close securely, stop using the product and keep it away from children. If you think batteries might have been swallowed or placed inside any part of the body, seek immediate medical attention.

WARNING



To replace the battery, operate as per the following steps:

Replace battery in remote key

- 1 Extend the mechanical key portion;
- 2 Pry off the battery cover from the key body;
- 3 Take out the battery and place a new one;

Note: *It is recommended to use a CR2032 battery.*

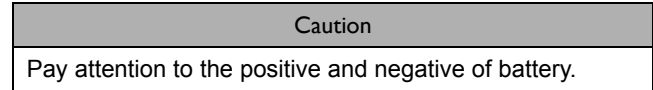

- 4 Then install the battery cover onto the key body.

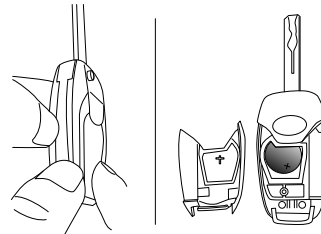

Before You Drive

Remote key with PEPS battery replacement

- 1 Release the button on the remote key with PEPS.
- 2 Remove the key head from the key itself.
- 3 Pry the upper and lower panels of the main body, remove the PCB (with battery) from the lower panel.

Caution

Never use a metal tool to pry the PCB.

- 4 Withdraw the old battery and fit the new battery.

Note: Batteries of type CR2032 are recommended.

Caution

It is essential that the correct battery polarization is observed.

- 5 Put the plastic support with battery into the lower panel of the main body, and install the PCB subsequently.
- 6 Refit the upper and lower panels of the main body.

Caution

Do not miss the waterproof shim onto the upper panel.

- 7 Press the key head into the main body.

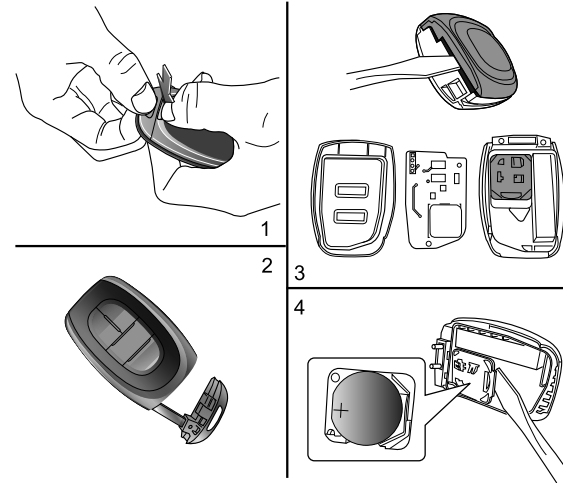

Caution

It is complicated to replace the battery in the remote key with PEPS. In order to prevent the key from being damaged due to misassembly or misoperation, you are recommended to have the battery replaced by our Service Dealer.

Before You Drive

Doors and Locks

Preventing the vehicle from theft



If you leave the vehicle while occupants are left in it, even if the departure time is very short, be sure to remove the key from the ignition switch, and special attention shall be paid especially when a child is left in the vehicle. Otherwise, they may start the engine or operate the electrical device, thus may result in a risk of accident.

Please close all windows before leaving the vehicle.

Please make sure that all doors are fully closed before locking.

Door Lock/Unlock

You may lock/unlock all doors from outside with the ordinary key, remote key, or remote control with PEPS. You may lock/unlock all doors from inside with the central lock switch. All doors can be locked automatically depending on vehicle speed. Please refer to "Central Lock System" in this section.

Note: *When all doors are successfully locked with the remote key, all turning signal lamps will flash once, and the horn sounds once as the reminder. When all doors are successfully unlocked with the remote key, all turning signal lamps will flash twice as the reminder.*

Central lock system

Using ordinary key, mechanical key section of remote control

Perform manual lock/unlock operation on the driver door from outside with the ordinary key or mechanical key section of remote control, all doors can be locked/unlocked.

When locking, turn the ordinary key or mechanical key section of remote control counterclockwise.

When unlocking, turn the ordinary key or mechanical key section of remote control clockwise.

Using remote key

With the buttons on the remote key, you can lock/unlock all doors through the central lock system.

Note: *The system can operate properly only when all doors are fully closed.*

Before You Drive

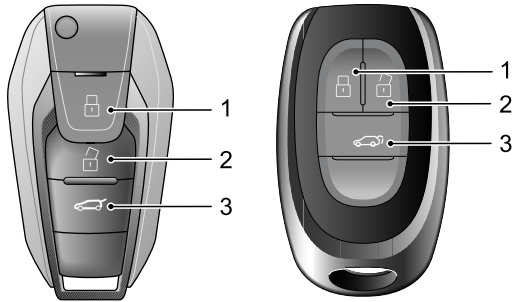

- 1 Center console LOCK button
- 2 Center console UNLOCK button
- 3 Manual tailgate UNLOCK button/Power tailgate UNLOCK & LOCK button

Caution

For vehicles with PEPS system, when locking with the LOCK button on the remote key with PEPS, if there is other legal remote key with PEPS in the vehicle, then the latter key will be disabled, and the passive entry and one touch start feature will be lost. To activate it: Close all doors, operate the UNLOCK button on the remote key with PEPS in a normal manner, the key being shielded inside the vehicle will be activated.

Locking all doors

Press the button (1) to lock all doors, but the prerequisite is that all doors are closed.

Note: All turning signal lamps flashing once represents the confirmation for locking, if any door is not fully closed, there will be no audio alarm, please press the button (1) again after closing all doors.

Unlocking all doors

Press the button (2) to unlock all doors.

Note: If no door is opened within 30 seconds, all doors will be automatically locked again.

Tailgate button

Long press the button (3) for 2 seconds, and the tailgate can be opened (power tailgate can be closed).

Before You Drive

Remote door lock with PEPS

PEPS system allows you to lock or unlock the doors without taking the remote key out of your pocket, wallet, or suitcase.

Unlock with the remote key with PEPS

As long as there is a legitimate remote key existing within the range of 1 meter around the vehicle, press the micro switch on the door handle, and the door will be unlocked.

Lock with the remote key with PEPS

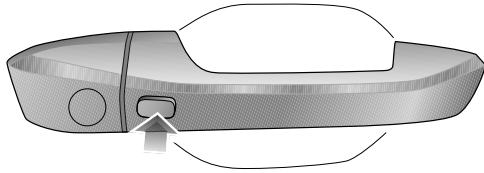

Turn off the ignition switch, leave the vehicle and close the door, then touch the micro switch with your thumb, the door will be locked, and there is no need to press the LOCK button on the remote key.

Using central lock switch

This switch can enable or disable all door locks from inside. Press the LOCK button to lock all doors. Press the UNLOCK button to unlock all doors.

Note: If the driver door is not closed, the lock motor will not activate, if the other door is not closed, the lock motor will activate.

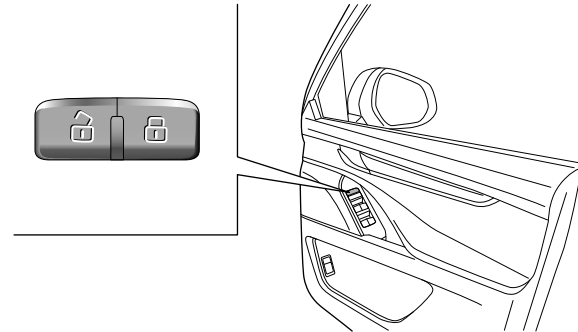

Before You Drive

The door can also be unlocked by pulling the inner handle twice.

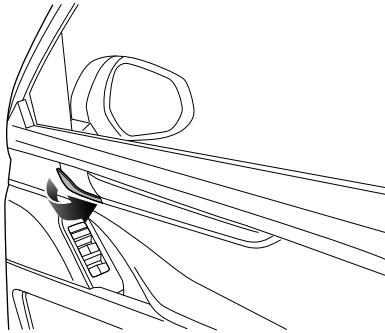

Note: During the driving, all doors shall be fully closed and all door locks shall be enabled, so as to avoid accidental opening of doors.

Speed related locking

This function will automatically lock all doors when the vehicle speed is over 8km/h.

Note: When the key is turned to "LOCK" position, remove the key, and the doors will be automatically unlocked.

Manual tailgate

Door unlock/opening from outside

When all doors are locked or unlocked with the key, remote key or central locking switch, the tailgate will also be locked or unlocked. If the tailgate is unlocked, it can be opened by pressing the handle button (1) and pulling it up.

Note: The tailgate swings up to open. When opening the tailgate, make sure there are no objects or people near the rear of the vehicle.

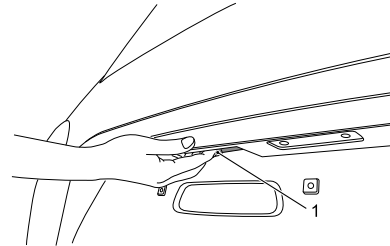

Door closing/lock from outside

To close the tailgate, lower the tailgate and press down firmly. Confirm that the tailgate is firmly locked.

Note: Confirm that the tailgate has been closed before driving. Driving the vehicle with the tailgate not closed may result in damage to the tailgate pneumatic lifter and other components.

Before You Drive

Power tailgate

Note: *The tailgate swings up to open. When opening the tailgate, make sure there are no objects or people near the rear of the vehicle. Confirm that the tailgate has been closed before driving. Driving the vehicle with the tailgate not closed may result in damage to the tailgate pneumatic lifter and other components.*

The power tailgate has 4 power opening modes, you may open and close the tailgate according to the configuration of your vehicle.

Tailgate opening/closing switch at the reading lamp

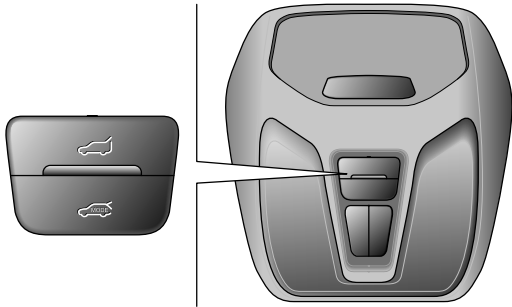

Press the switch , and the tailgate will perform the opening/closing action.







Remote key

Long press the  on the remote key for 2 seconds, and the tailgate will perform the opening/closing action.

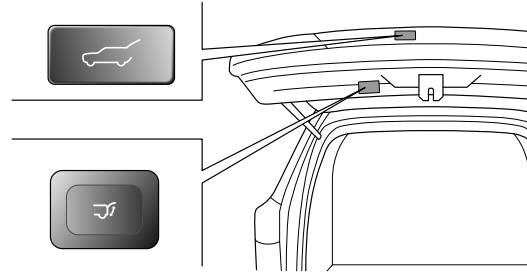
Switch on the tailgate

Press the tailgate exterior panel switch  to perform the tailgate opening action. Please ensure that the vehicle is in unlock state, if the vehicle is not entirely unlocked, you need to bring the remote key near the tailgate, and perform the opening/closing action with the tailgate exterior panel switch .



Press the tailgate interior panel switch  to perform the tailgate opening and closing. If the tailgate is open, press the tailgate interior trim panel switch  to close the power tailgate. The switch  can achieve the 2-way action, that is, during the tailgate opening or closing, press the switch to stop the tailgate action, and press it again to perform the reverse action.

Before You Drive

Foot kick sensing switch on the tailgate

The tailgate is equipped with an inductive opening system, with the remote key (The remote key must be in a semicircular area with a radius of about 1 m of the tail gate of the vehicle), take a kick action under the rear bumper to open the tailgate. When doing this, gently kick forward with a foot toward the bottom of the rear bumper (as shown in the figure) and then take it back, but do not touch the bumper.

Note: *Confirm that the tailgate has been closed before driving. Driving the vehicle with the tailgate not closed may result in damage to the tailgate pneumatic lifter and other components.*

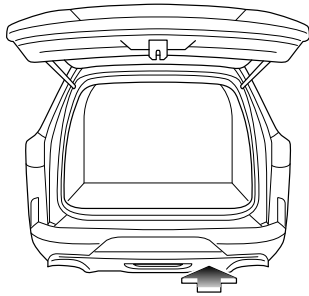

Caution

When operating the power tailgate, ensure that no one is in the opening and closing path of the tailgate, or you or others may be injured. During washing your car, ensure that the remote key is kept far away from the rear bumper detection area, for water flushing may cause the tail gate opening. If the rear bumper is covered by a large amount of ice and snow, dirt or similar materials, the Easy-Open Tail Gate feature may be degraded or disabled, so please keep the cleanliness of the rear bumper.

1

Before You Drive

Tailgate height setting

Fully open mode

The fully open mode is the vehicle default mode.

Garage mode

For the garage mode, you need to press the tailgate garage mode switch  mode button at the reading lamp, and then the tailgate will be opened to the set garage height in each opening. The default opening of the tailgate in the garage mode is 75%.

Setting of the garage mode: manually open the tailgate to the desired height, long press the tailgate interior panel switch button for 3 seconds, if ticks are heard, it indicates that the setting is successful. Press the garage mode switch, the tailgate will be opened to the garage height in the following opening.

Emergency lock function of the tailgate

The tailgate has emergency lock function, in case of whole vehicle power-off or other power tailgate failures, you may open the cover at the lower end of tailgate interior trim panel, push the lever in it to open the tailgate.

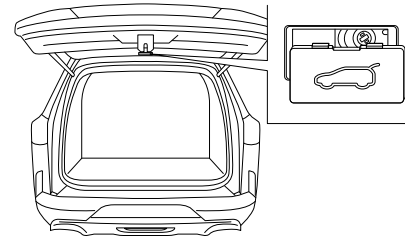

Note: For vehicle models with automatic transmission, only when the shift lever is placed in “P” position can the power tail gate be opened or closed; for vehicle models with manual transmission, the power tail gate can be opened or closed whichever gear position the shift lever is placed in.

If no operating instruction is received 15 minutes after the power tailgate is opened, the tailgate enters the suspend mode. The customer needs to close the door manually once to restore the power mode. When the power tailgate is opened again, it can be opened and closed electrically.

The power tailgate cannot be opened and closed consecutively for 10 cycles, or the thermal protection may be activated. If the tailgate thermal protection of your vehicle is activated, be sure not to operate the tailgate, and wait for 1 minute, and proceed the tailgate operation after the thermal protection disappears.

If the tailgate encounters an obstacle in the power opening or closing cycle, the tailgate will automatically move in the

Before You Drive

opposite direction to avoid the obstacle. After the obstacle removal, you may operate the power tailgate again. If the tailgate encounters obstacles for consecutive 3 times in the power closing or opening process, the power function will be disabled. After the obstacle is removed, manually close the tailgate, and the normal power operation can be restored. The anti-pinch sensor is located at the side of the tailgate, when the tailgate is closed, if there is an obstacle between the tailgate and vehicle and the sensor is squeezed, the tailgate will rotate 5° in the opposite direction.

When operating the power tailgate, ensure that no one is in the opening and closing path of the tailgate, or you or others may be injured.

Tailgate follow-up movement strategy: when the power tailgate is in the ajar position, it will be automatically closed when a force is applied on it.

Please do not forcibly open or close the tailgate by hand in the power operating cycle.

When the vehicle is on a ramp of 12° or above, please close the tailgate with the assist of your hands, and please note that the closing action must be slow, and do not close the tailgate rapidly and forcibly.

If the battery is disconnected or the voltage is too low, then the tailgate cannot be opened. When the battery is reconnected or charging, the tailgate will resume its operation.

Child safety door lock

! Where a child sits in the rear passenger seat, the doors should be locked by the child safety door locks.

Each side rear door of your car is provided with a child safety door lock. These doors are used to prevent passenger, especially the child, from opening the side rear door due to careless pulling of the internal door handle.

Caution

When the child safety lock is locked, do not pull the internal door handle with a heavy force. This practice will cause damage to the internal door handle.

The left rear door's child safety door lock

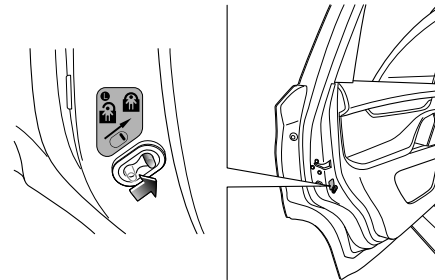

Before You Drive

The right rear door's child safety door lock

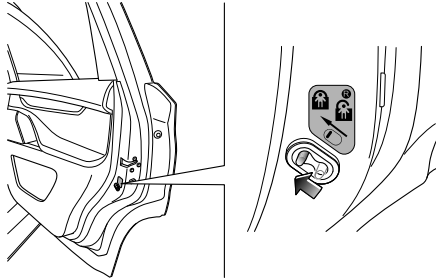

To start the child safety door lock:

- 1 Open the side rear door you want to lock.
- 2 Find the child safety lock control lever.
- 3 Pull the control lever to the locking position .

Caution

Each side rear door is provided its respective lock. The child safety door lock of each side rear door must be activated or deactivated by hand, regardless of the lock at right side or left side.

To open the side rear door after the child safety door lock is activated, the door can be opened only by the external door handle. To deactivate the child safety door lock, it is necessary to push the control lever up to the unlocking position .

Windows

 It is dangerous to leave children, incapacitated adults or pets on the vehicle with windows closed. They may faint out due to high temperature, or suffer permanent injury or even death due to heat stroke. Do not leave children, incapacitated adults or pets on the vehicle, especially in the warm or hot weather, with the windows closed.

Power window

 Always take care when operating the power window. There is a risk of injury, especially for the children. Please pay close attention when closing the window. Ensure that no objects are stuck in it while the window is moving.

Driver door window

There are 4 window switches  on the driver door. You can operate driver door window, front passenger door window and rear door windows respectively with these 4 switches.

When operating, press the front part of the switch to open the window. Pull the front part of the switch to close the window.

The driver may operate the lock button  to disable the power windows for rear occupants. To enable this function, press the lock button again.

Before You Drive



Automatic lifting function of driver door window

Your vehicle may be equipped with one-touch up/down or one-touch down function. Button 1 has 2 levels: auto up/down and stroke up/down, so it can conveniently control the window glass up/down process. Briefly press the window button up or down to the second level, and the window glass will automatically move up or down.

Resume the automatic up/down function

If the vehicle battery cable is re-connected after the disconnection, or the battery was drained once, or the anti-pinch function has been enabled for consecutive 3 times at the same position when the window glass moves up, the automatic up/down function may not work, it must be re-learned to restore the function.

Close all doors, pull up the window glass lifting button, until the window is fully closed, hold the button for about several seconds after the window is fully closed; then press the window glass lifting button until the window is fully open, hold the button for about several seconds after the window is fully open, the automatic up/down function will resume.

Occupant door windows

There is only 1 window switch on each occupant door , which can only operate the corresponding occupant door window.

When operating, press the front part of the switch to open the window. Pull the front part of the switch to close the window.

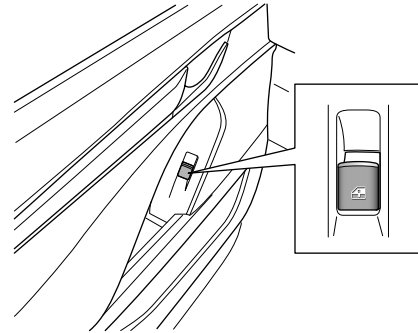

Note: Power windows can operate only when the ignition switch is in "ON" position.

Before You Drive

Power sunroof

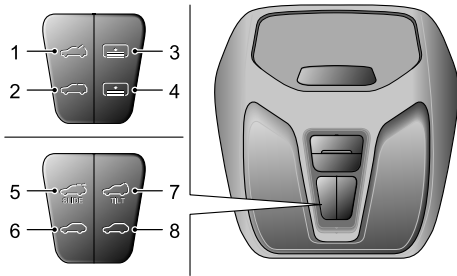

Position 1 – : panoramic sunroof Open switch.

Position 2 – : panoramic sunroof Close switch.

Note: The opening and closing of panoramic sunroof has 2 gears: tilt for ventilation and fully open, makes it easy to control the opening and closing process of the sunroof. With the first gear of the switch, the sunroof will be opened or closed to the tilt for ventilation position, with the second gear of the switch, the sunroof will be fully opened or closed. Meanwhile, both the opening and closing of panoramic sunroof switch are equipped with jog and auto function, make it easy to control the opening and closing process of the sunroof. Short press the second gear of the operating button, the sunroof will be automatically opened or closed. Long press the first gear for jog function.

Position 3 – : sunshade Open switch.

Position 4 – : sunshade Close switch.

Note: Both the opening and closing of sunshade switch are equipped with jog and auto function, make it easy to control the opening and closing process of the sunshade. Short press the second gear of the operating button, the sunshade will be automatically opened or closed. Long press the first gear for jog function.

Position 5 – : sunroof Slide Open switch. When the sunroof slides open, release the button to stop the sunroof at the desired position.

Position 6 – : sunroof Slide Close switch. When the sunroof slides close, release the button to stop the sunroof at the desired position.

Note: Both the opening and closing of sunroof switch are equipped with jog and auto function, make it easy to control the opening and closing process of the sunroof. Short press the second gear of the operating button, the sunroof will be automatically opened or closed. Long press the first gear for jog function.

Position 7 – : sunroof Tilt Open switch. When the sunroof tilts open, release the button to stop the sunroof at the desired position.

Position 8 – : sunroof Tilt Close switch. When the sunroof tilts close, release the button to stop the sunroof at the desired position.

Before You Drive

Seats

Driver seat adjustment

 Do not adjust the driver seat while the vehicle is running. If so, the vehicle may be out of control and result in an accident.

Manually adjusted driver seat

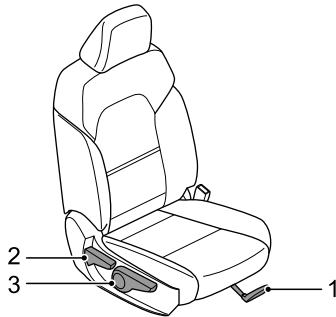

Forward/backward sliding

Pull up the handle (1), and slide the seat to the desired position. Release the handle (1) and confirm that the seat is locked in place.

Backrest adjustment

 The tilt angle of driver seat should not be too large, the seat belt can provide the maximum protection only when the seat back forms an angle of about 25° with the vertical direction.

With the body tilting slightly forward, pull up the adjusting handle (2), the seat back will automatically bounce back, then recline against the seat back to adjust it to the desired angle. Release the adjusting handle (2) and confirm that the seat back is locked in place.

Cushion height adjustment

Pull up the adjusting handle (3) to raise the seat height, and press the handle (3) to lower the seat height. When making significant adjustments, it is required to pull up and press the handle (3) consecutively.

Before You Drive

Electrically adjusted driver seat

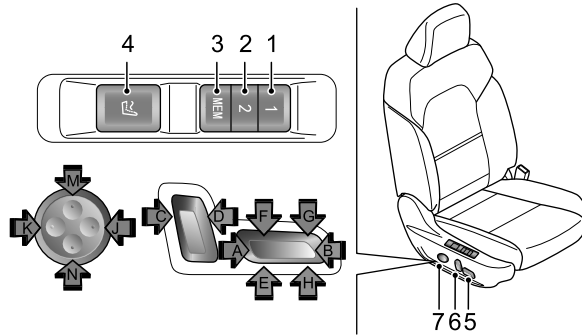

Caution

Regardless of where the ignition switch is placed, the seat can be slid back and forth, the backrest and the tilt angle and height of cushion can be adjusted. But the electrical adjustment is power consuming, which may drain the battery. The lumbar support adjustment and massaging and memory position functions can be enabled after the engine start.

Forward/backward sliding

When the button (5) is pushed forward (arrow A), the seat will move forward, and when the seat slides to the desired position, release the button (5) to stop the seat sliding.

When the button (5) is pushed backward (arrow B), the seat will move backward, and when the seat slides to the desired position, release the button (5) to stop the seat sliding.

Backrest adjustment

! The tilt angle of driver seat should not be too large, the seat belt can provide the maximum protection only when the seat back forms an angle of about 25° with the vertical direction.

When the button (6) is rotated forward (arrow C), the seat backrest will tilt forward, when the seat backrest tilts to the desired position, release the button (6) to stop the tilting.

When the button (6) is rotated backward (arrow D), the seat backrest will tilt backward, when the seat backrest tilts to the desired position, release the button (6) to stop the tilting.

Cushion inclination adjustment

When the front end of button (5) is pulled upward (arrow H), the front end of cushion will raise, when the cushion tilts to the desired position, release the button (5) to stop the cushion movement.

When the front end of button (5) is pulled downward (arrow G), the front end of cushion will lower, when the cushion tilts to the desired position, release the button (5) to stop the cushion movement.

Cushion height adjustment

When the rear end of button (5) is pulled upward (arrow E), the cushion will move upward, when the cushion raises to the desired position, release the button (5) to stop the cushion movement.

When the rear end of button (5) is pulled downward (arrow F), the cushion will move downward, when the cushion lowers to the desired position, release the button (5) to stop the cushion movement.

Lumbar support adjustment

When the front end of button (7) is pressed and hold (arrow J), the lumbar support will move forward, when the lumbar support moves to the desired position, release the button to stop the lumbar support movement.

When the rear end of button (7) is pressed and hold (arrow K), the lumbar support will move backward, when the lumbar support moves to the desired position, release the button to stop the lumbar support movement.

When the upper end of button (7) is pressed and hold (arrow M), the lumbar support will move upward, when the lumbar support moves to the desired position, release the button to stop the lumbar support movement.

When the lower end of button (7) is pressed and hold (arrow N), the lumbar support will move downward, when the lumbar support moves to the desired position, release the button to stop the lumbar support movement.

Massaging

Press the button (4) to carry out a massaging, 10 minutes later, the massaging will be automatically turned off after the completion of 30 seconds' bleeding. If the button (4) is pressed again within 10 minutes, the massaging will be turned off.

Memory position function setting

- Storage

Press (press and release) the memory switch button (3) first, then press the button (1) in 3 seconds until a sound of buzz is heard, which indicates the successful completion of memory and that the seat posture and the position of exterior rearview mirrors at the time have been stored in the button (1).

Press (press and release) the memory switch button (3) first, then press the button (2) in 3 seconds until a sound of buzz is heard, which indicates the successful completion of memory and that the seat posture and the position of exterior rearview mirrors at the time have been stored in the button (2).

- Recall

Press the button (1) or (2), to recall the seat posture and the position of exterior rearview mirrors stored correspondingly. During the recall, operate any adjusting switch of the seat or the exterior rearview mirror to stop the recall; press the corresponding button again to continue the recall.

Before You Drive

Front passenger seat adjustment

Manually adjusted front passenger seat

Only forward/backward sliding and seat backrest adjustment can be made, and its adjustment is consistent with that of manually adjusted driver seat.

Electrically adjusted front passenger seat

Only forward/backward sliding, seat backrest adjustment and lumbar support adjustment can be made, and its adjustment is consistent with that of electrically adjusted driver seat.

2nd row seats adjustment

Type I

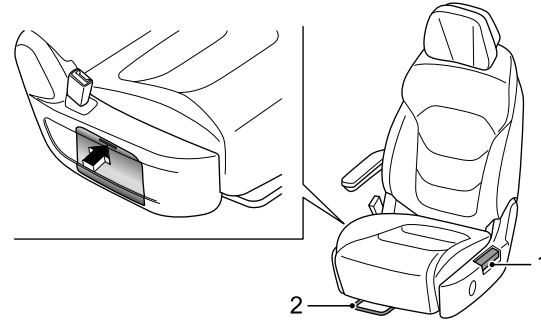

Seat backrest adjustment

With the body tilting slightly forward, pull up the handle (1), then recline against the seat back to adjust it to the desired angle. Release the handle (1) and confirm that the seat backrest has been locked in place.

Forward/backward sliding

Pull up the unlock lever (2), pull forward or push backward with your feet to adjust the seat position, release the unlock lever (2), and confirm that the seat backrest has been locked in place.

Before You Drive

Lumbar support adjustment

Its adjustment is consistent with that of electrically adjusted driver seat.

Lumbar support massaging

Its adjustment is consistent with that of electrically adjusted driver seat.

Foldable cup holder

The left individual seat is equipped with a foldable cup holder, press the location indicated by the arrow, the cup holder will eject. Press the cup holder inward when it is not in use.

Armrest adjustment

There are 6 positions for the armrest adjustment, from the lowest position upward to the desired position.

To adjust the armrest from the high position to the low position, it is required to adjust it to the highest position first, then to the lowest position and then adjust it upward to the desired position.

Type II

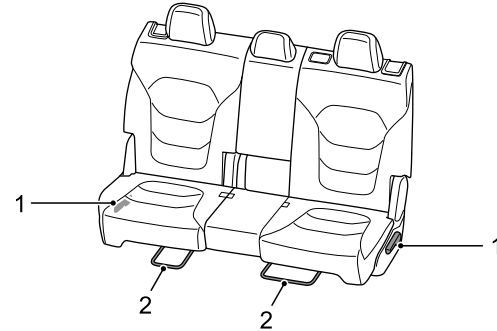

Seat backrest adjustment

With the body tilting slightly forward, pull up the handle (1), then recline against the seat back to adjust it to the desired angle. Release the handle (1) and confirm that the seat backrest has been locked in place.

Seat backrest folding adjustment

Move the head restraint to the lowest position before the adjustment. Pull up the handle (1), the seat can be automatically flattened.

The user can also flatten the 2nd row seats from the luggage compartment (if equipped). Pull the handle (3) outward, the right

Before You Drive

2nd row seat will be automatically flattened. Pull the handle (4) outward, the left 2nd row seat will be automatically flattened.

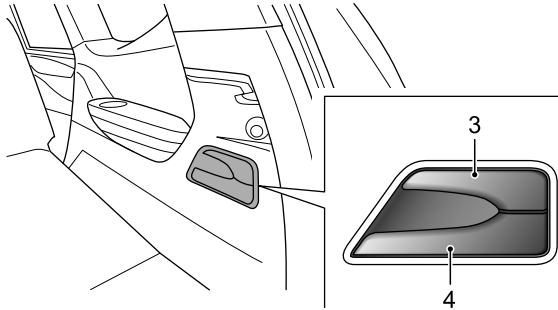

Lift the seat backrest until it is locked, so that the seat backrest is restored to the position for normal use.

Caution

When the 2nd row seat backrests are folded, they may interfere with the front seats, be careful to avoid bumping.

Forward/backward sliding

Pull up the unlock lever (2), pull forward or push backward with your feet to adjust the seat position, release the unlock lever (2), and confirm that the seat has been locked in place.

Easy entry function for the 2nd row three-abreast seats

This function will provide convenience for the entry/exit of 3rd row passengers.

Entry/exit of 3rd row passengers from the right side

Pull up the unlock lever (5), tilt the seat backrest forward at a certain angle, and move the seat to the foremost position. At this time, the rear passengers can get on/off the vehicle from the right side.

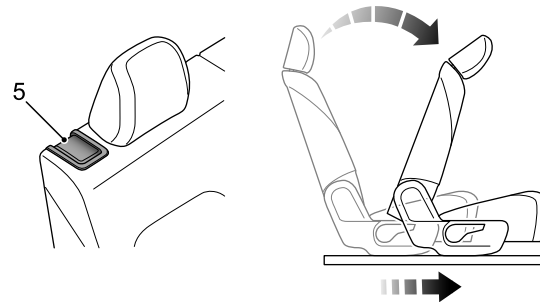

After the entry/exit of rear passengers, restore the seat backrest position, and move the seat backward to the locked position.

Before You Drive

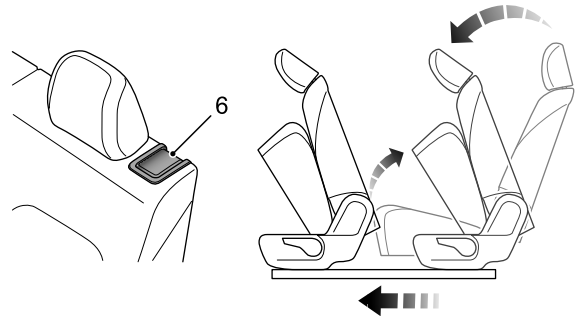
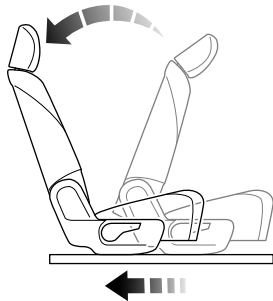

1

Entry/exit of 3rd row passengers from the left side

Pull up the unlock lever (6), tilt the seat backrest forward at a certain angle, the seat cushion will be automatically folded upward, and then move the seat to the foremost position. At this time, the rear passengers can get on/off the vehicle from the left side.

After the entry/exit of the passenger, restore the seat backrest position, and press the cushion downward to the locked position after the backrest is locked. If necessary, adjust the seat forward or backward to the appropriate position through the slide rod.

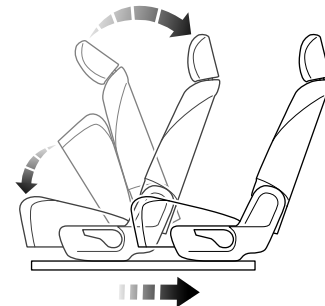

Before You Drive

3rd row seats adjustment

Seat backrest folding forward

Caution

With the 2nd row seat backrests tilting backward, folding the 3rd row seats may interfere with the 2nd row seats, at this time, please move the 2nd row seats forward or decrease the tilting angle of 2nd row seat backrests.

Straighten the buckle and webbing and put the buckle back in the seat slot, otherwise the buckle will protrude against the seat back when the seat back is laid flat, which tends to cause damage to the seat trim cover.

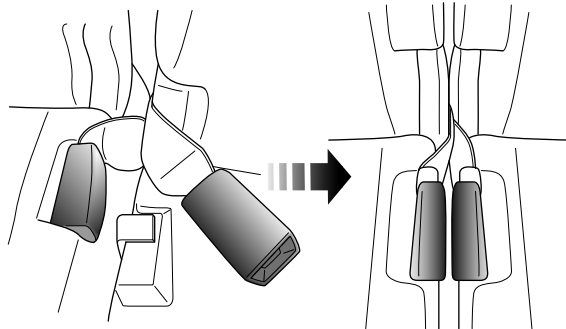

Move the head restraint to the lowest position before the adjustment. Pull the unlock strap at the upper part of the seat backrest, fold the backrest forward until it is against the cushion.

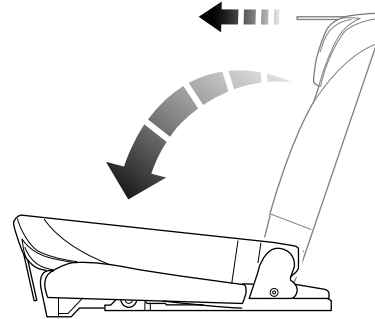

Before You Drive

Seat backrest unfolding backward

Pull the unlock strap at the back of the seat backrest to rear upper side, to unfold the seat backrest backward to the locked position. Adjust the head restraint to the locked position.

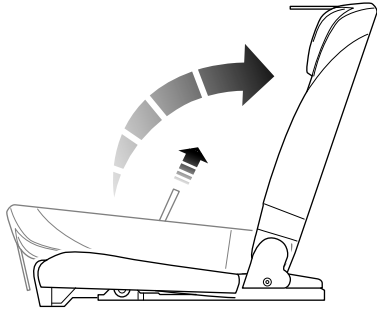

Caution

When the third row seats are being used, the head restraint must be lifted up and out of the stowage position and locked in the use position.

Seat middle armrest adjustment

Pull it down and push it forward for use.

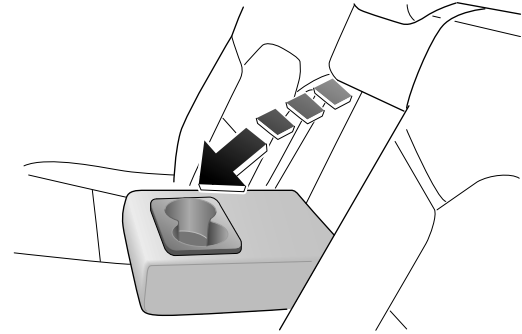

Caution

Do not sit on the central armrest or place heavy objects on it.

Before You Drive

Head restraints

! To reduce the risk of neck or head injury, the head restraints shall be adjusted to support the back of the head rather than the neck. Before driving, adjust and ensure that the head restraints of front and rear seats are in locked position (this locked position is the safe use position). Do not adjust the head restraint while the vehicle is running.

Type I

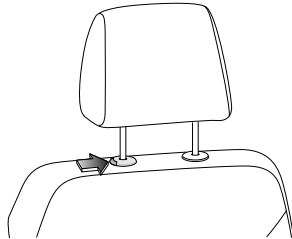

Pull the head restraint upward to adjust it to the desired position. To remove the head restraint after lifting it to the highest position, press the button indicated by the arrow.

Press the button indicated by the arrow to push the head restraint downward to the desired position.

Type II

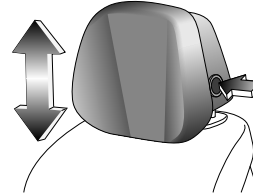

Press the button indicated by the arrow to push the head restraint downward or pull it upward, so as to adjust the head restraint to the desired position.

The head restraint can be adjusted back and forth, pull the head restraint hard to the desired position, then release it. When the head restraint is pulled to the very front, it will restore to the final position after release.

Both sides of the head restraint are adjustable. Rotate both sides of the head restraint hard to the desired position, then release it.

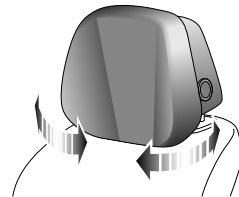

Occupant Protection Device

Properly seated

The seats and the occupant protection device are designed to minimize the risks of personal injuries when accident occurs. Observe the following points to achieve the best results.

- Do not make the seat too close to the steering wheel.
- Do not tilt the seat excessively. Do not tilt the seat back more than 30°, so that you can seat yourself vertically with the slightly bent arms and the root of the spine should be backward as possible as you can.
- The center of the head restraints should be adjusted to the back of your head, rather than the neck.
- The shoulder belt should go through the center of your shoulder (adjust its height as necessary), while the lap belt should be put around the hip tightly, rather than the abdomen.

Seat belt



Improper seat belt wearing or use may result in the serious personal injury or death. The seat belt is one of life-saving equipments. In the event of accidents, the unprotected occupant may knock against any part of the vehicle or be thrown out of the vehicle, resulting in himself/herself or others being injured.

The driver and any adults (including children with body height similar to that of an adult) must always wear a seat belt on all journeys. Do not loosen the belt that fastened on your body. The seat belt must be always fastened tightly around the body to achieve the best protection. Avoid wearing the thick and big volume clothing. Have the shoulder belt of seat belt across the middle of the shoulder and the lap belt across the crotch against the body. The use of loose or twisted seat belt is strictly prohibited, and the seat belt cannot be worn twisted.

Each belt should be used by just one occupant only. Do not put a belt around a child seated on the occupant's lap. The seat belt is intended for use by adult-sized occupants only. Children should be restrained in the correct child restraint device.

The belt should be straight and fastened when you wear it. Otherwise, the belt can not be operated smoothly. The buckle button must be facing outward.

Before You Drive

 Do not hold an infant or child on your lap. They will become too heavy to restrain in case of collision.

Prevent the foreign materials (especially the sugary food and drinks) from entering the seat belt buckle, as those materials may cause the buckle fault.

If the seat belt has been used in a severe accident or shows signs of severe fraying or having been cut, or when a seat belt is equipped with a pre-loading device, when the latter has been activated, the seat belt assembly shall be replaced.

The expectant mother should ask the doctor about the safest method to wear the belt.

Do not modify or change the seat belt in any way as this may cause the belt fault. Do not disassemble, repair or lubricate the retractor or buckle mechanism.

Each seat belt is equipped with a retractor, when a seat belt is pulled out slowly, the retractor can ensure the smooth retraction of the belt. But if a seat belt is pulled out too fast, or in a sudden impact (hard deceleration, acceleration, and a sharp turn), the seat belt will be locked. Please refer to "Seat Belt" in Maintenance and Service section for specific check methods.

 When not in use, be sure to fully retract the seat belt webbing, straighten the webbing and put the locking tab in place, keep the webbing and locking tab clean and away from dust and impurities.

Care shall be taken to avoid erosion to the webbing caused by polishing agents, oils and chemicals (especially battery acid). The belts can be safely cleaned with mild soap and water. The seat belt shall be replaced when the webbing has wear, erosion and damage occurred.

This vehicle series are equipped with lap-shoulder belts, and the lap-shoulder belts are classified into the adjustable seat belt without pretensioner, the adjustable set belt with pretensioner, and the adjustable seat belt with dual pretensioners. Only the front seats can be equipped with the adjustable seat belt with dual pretensioners. Only the front seats and outboard seats of the second row may be equipped with the adjustable seat belt with pretensioner.

 When the locking tab is pushed into the buckle, the seat belt is locked until a clear "clicks" is heard.

Before You Drive

Adjustable Seat Belt with Pretensioner (Shoulder Belt Pretensioner)

In the event of serious collision accident, the pretensioner (integrated into the retractor) will be activated by the sensor, the shoulder belt (1) will be retracted a little immediately to prevent the occupants from moving forward and make them seated securely, so that it improves the function of the seat belt further.

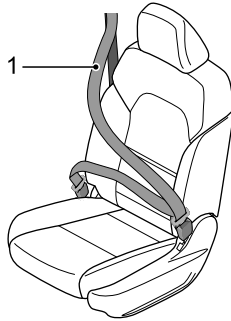

Adjustable Seat Belt with Dual Pretensioners (Shoulder / Lap Belt Pretensioner)

In the event of serious collision accident, the dual pretensioners (one integrated into the retractor, the other integrated into the side lap belt alarm) will be activated by the sensor, the shoulder belt (1) and the lap belt (2) will be retracted a little immediately at the same time to prevent the occupants from moving forward and make them seated securely, so that it improves the function of the seat belt further.

1

Caution

The outer locking tab (3) does not need to be unlocked in the daily use. The outer locking tab (3) should be unlocked by using the special tool, please ask our Service Dealer to unlock it, if necessary.

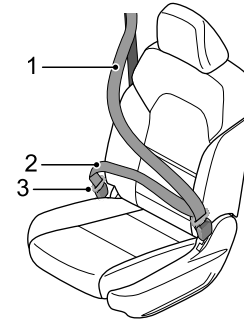

Before You Drive

Seat Belts for Front Seats

Fastening

Pull out the seat belt slowly, have it passed over the shoulder and then the front of the body, confirm that it is not twisted or tied, then push the locking tab into the buckle until a click is heard.

Releasing

Press the red button on the buckle, then the locking tab will pop out under the action of the elastic force. Deliver the locking tab back manually, so that the automatic seat belt retractor can fully retract the seat belt more smoothly.

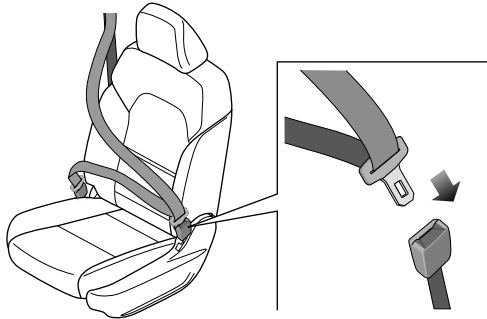

Seat Belts for 2 Seats in Second Row

The seat belts for 2 seats in 2nd row are fastened and released in the same way as the seat belts for front seats.

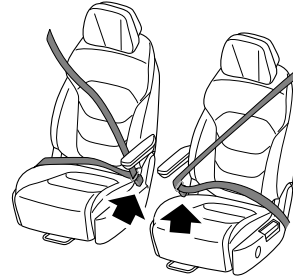

Seat Belts for 3 Seats in Second Row

The seat belts for 3 seats in second row are fastened and released in the same way as the seat belts for front seats.

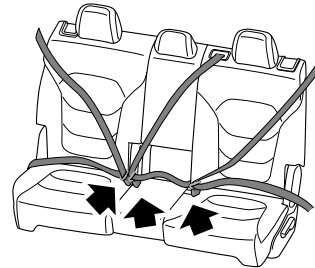

Before You Drive

Seat Belts for 2 Seats in Third Row

The seat belts for 2 seats in third row are fastened and released in the same way as the seat belts for front seats.

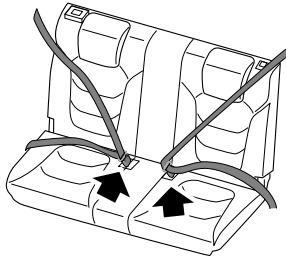

Seat Belts for 2 Outboard Seats in Third Row

The seat belts for 2 outboard seats in third row (with 3 seats) are fastened and released in the same way as the seat belts for front seats.

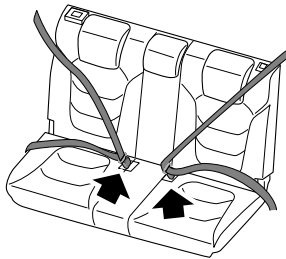

Ceiling Seat Belt for Middle Seat in Third Row (With 3 Seats)

Fastening

Pull out the seat belt from the ceiling, have the fixed locking tab (2) pushed into the left buckle, and have the movable locking tab (1) passed over the abdomen and pushed into the right buckle.

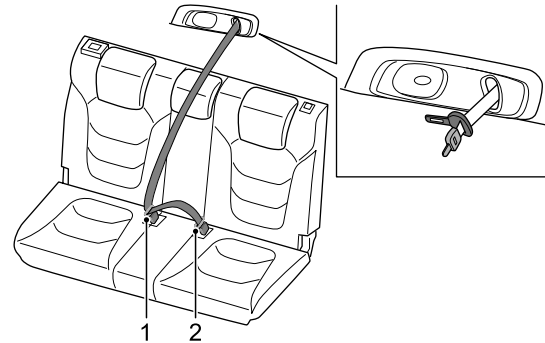

Seat Belt Comfort Guide Ring

The seat belt comfort guide ring is fitted on the shoulder belt, which can take the shoulder belt away from the head of the left occupant.

Take the guide ring out of the seat back storage bag.

Before You Drive

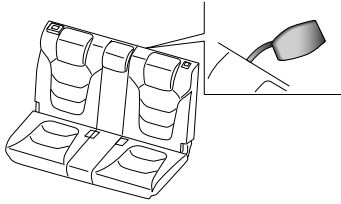

Put the guide ring on the shoulder belt, then insert both edges of the seat belt into the opening of the guide ring.

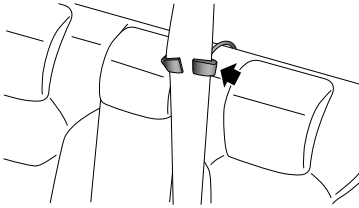

Ensure the seat belt is smooth, and the guide ring must be above the seat belt.

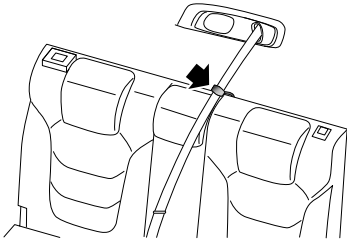

Releasing

To withdraw the seat belt comfort guide ring, squeeze both edges of the seat belt together and remove the seat belt from the guide ring. Then stow the guide ring in the seat back storage bag.

The movable locking tab (1) is unlocked by pressing the red button on the right buckle.

The fixed locking tab (2) can be drawn out by inserting a key or other sharp objects into the left buckle unlocking hole. Deliver the locking tab back manually, so that the automatic seat belt retractor can fully retract the seat belt more smoothly.

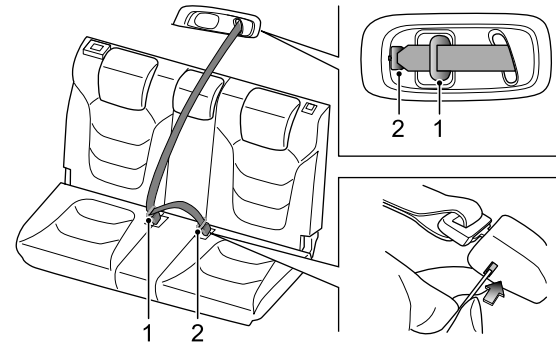

Note: After the seat belt is retracted to the ceiling, the locking tab can be clipped on the ceiling.

Before You Drive

Plastic Hooks for Side Seat Belts

When not in use, the side seat belts for second and third rows can be snapped into the side seat belt hooks.

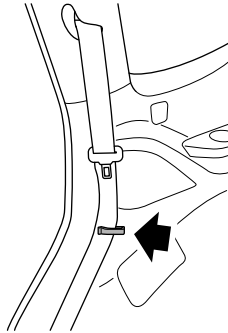

Seat Belt Warning Lamp

For the specific details of "Seat Belt Warning Lamp", please refer to "Information Center" and "Warning Lamps and Indicators" in this section.

Seat Belt Height Adjustment

! Ensure that the sliding adjuster is secured after the adjustment.

Do not adjust the height of the driver seat belt when driving, or the vehicle may be out of control.

Only the height of the driver and front passenger seat's lap-shoulder belt can be adjusted.

Push the button (1) upward and slide the height adjuster on the top of the belt up and down to suit the occupant height. Release the button (1) at the proper position, pull the seat belt forcibly to ensure that the vertical adjuster is locked reliably.

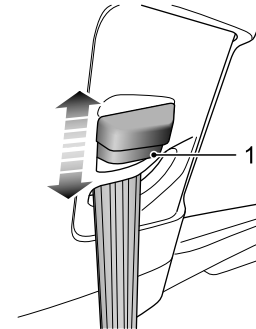

1

Before You Drive

Seat belt pretensioner

 Do not damage or repair the pretensioner. As it contains the ignition device, so it can only be repaired by our Service Dealer.

The pretensioner will be invalid once being activated, so it must be replaced. Ensure that our Service Dealer has checked and repaired the pretensioners and all seat belt components after the collision.

The seat belt pretensioner works with the airbag to reduce the risk of injury caused by the frontal impact. Refer to "Airbag" in this chapter for more information.

Airbag

 None protection device is absolutely safe, when used to avoid the occurrence of serious collision, it may result in the personal injury or death. Even though the seat belt is worn properly and the airbag is inflated, it may also result in the personal injury or death.

When inflated, some components of the airbag will be hot, so do not contact it before cooling down.

Airbag inflation may lead to the occupant facial abrasions or other injuries, such injuries can be minimized only if you and your occupants wear the seat belt.

The driver seat should be adjusted to the back as far as possible without affecting your driving.

Always hold the steering wheel rim, so that the airbag would not be interfered when inflating.

Do not put any accessory (eg. mobile phone holder, cup base, tray) on the steering wheel cover or the airbag cover plate of the instrument panel, also do not paste (or insert) any objects onto the airbag module cover. Otherwise, it will affect the airbag inflation, or these objects will be blown to any area of the interior when the airbag is inflated, resulting in the occupant injury.

Before You Drive



For the seat with seat airbag, it is forbidden to set the seat cover or other decorative items that affect the deployment of seat airbag.

Do not modify the seat with seat airbag.

Do not paste any sharp items on the A/B/C/D pillar of the vehicle or modify these pillars to avoid injury to occupants during the operation of airbag.

The occupants must not contact or access to the airbag cover plate of the instrument panel with their foot, knee or other body parts, or it may impede the deployment of the airbag.

The seat belt pretensioner works with the airbag to reduce the risk of injury caused by the frontal impact.

Do not remove or knock the steering wheel violently, also do not punch the steering wheel.

The space between the driver and the airbag deployment area should not be occupied by others, animals or objects. So is the occupant side equipped with airbag.

Do not repair the steering wheel, steering column, any airbag unit, pretensioner component or airbag component surrounded with wiring by yourself, or the airbag may be activated accidentally, resulting in personal injury. Do not modify the front of the vehicle in any way as this may affect the deployment of airbag.



The disposal of the undeployed airbag on the vehicle exists the potential risk, it should be deployed before the disposal. This operation must be performed by the professionals.

This vehicle can be equipped with the driver airbag, front passenger airbag, front seat side airbag and side curtain airbag.

Note: *Both the airbag and the pretensioner are supplementary protection device, while the seat belt is still the main protection device and must be worn during driving.*

Caution

- A loud noise may be heard and a little of gases similar to smoke and the dust will be released when the airbag is activated. Such smoke would not be harmful to the health. The dust may cause the skin irritation, so wash the skin area with soap and water.
- For safety reasons, the airbag should be replaced every 10 years, you are recommended to have it replaced by our Service Dealer. The owner has the obligation to inform the buyer about the Notices and Cautions listed above when the vehicle is sold. The original owner is considered to fulfill his/her obligation once these instruction files (see Owner Warranty and Maintenance Manual) are delivered to new owner.

Before You Drive

Airbag and Pretensioner Inspection

⚠ If the ignition switch is turned on, the warning light is not turned on or not turned off after 6 seconds, or turned on when driving, it indicates that the airbag pretensioner or the airbag is faulty. Please contact our Service Dealer for service as soon as possible.

Once the ignition switch is turned to the ON position, "Airbag



warning light (red)" will blink for about 6 seconds, indicating that the airbag and the seat belt pretensioner are being checked; after 6 seconds of blinking, the light will go out, indicating that the airbag and the seat belt pretensioner are normal.

Airbag Deployment

In the event of a collision, the airbag control unit monitors the rate of deceleration or acceleration induced by the collision, then determines whether the airbags should be deployed.

Operation of the airbag is not dependent on the vehicle's speed, but on the collision objects, the collision direction, the collision location and the changing rate of the vehicle's speed. Deployment of the airbag should not be determined by the vehicle's damage severity.

Airbag deployment is virtually instantaneous and occurs with considerable force, accompanied by a loud noise. The deployed airbag, together with the seat belt restraint system, limit the

movement of the driver and the front passenger, thereby reducing the risk of injury to the head and upper torso.

After the deployment, the airbags deflate immediately, which ensures that the driver's forward vision is not obscured.

Note: When it is deployed, some airbag components are hot, so do not contact it before cooling down.

- Schematic Diagram for Deployment Area of Driver and Front Passenger Airbags

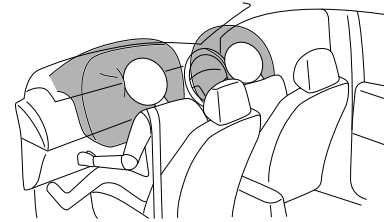

- Schematic Diagram for Deployment Area of Side Airbags and Curtain Airbags

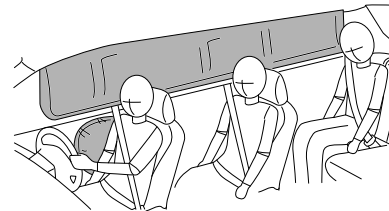

Before You Drive

Replacement of SRS Components after a Collision

⚠ Collision accidents may damage the SRS on the vehicle. Airbags may not function properly after damage, and can not protect you and other passengers when a collision accident occurs, which may cause the serious personal injury or death. To ensure that SRS can function properly after the collision, please ask our Service Dealer to check and repair the SRS as necessary.

Once the airbag is inflated, the parts of SRS need to be replaced. Please contact our Service Dealer for service as soon as possible.

Child restraints (not available with the vehicle)

⚠ May result in death or serious injury!
The airbag can kill the children under 12-year old. The backward-facing child or infant restraint device is prohibited being installed on the front seat, otherwise it will result in the serious children or infant injury or death when the airbag is expanded. Seat yourself far away from the airbag as possible as you can.

Observe the instructions provided by the infant or child restraint device's manufacturer if you are installing or using such device.

WARNING: child restraint anchorages are designed to withstand only those loads imposed by correctly fitted child restraints. Under no circumstances are they to be used for adult seatbelts, harnesses, or for attaching other items or equipment to the vehicle.



Before You Drive

Compared with adults, children are more vulnerable by the expanded airbag. So, it is recommended that the children under 12 years old should seat on the rear seat. Generally the babies under 2 years old should use the infant restraints, and the children aged from 2 to 4 years old should use the children restraints. The infant or children restraints are available in the market.

There are various size and types of infant or children restraints, you are recommended to choose the suitable protection device depending on the infant's or children's age and weight to achieve the best protection. When making the choices, it is important to note that if this protection device is suitable for your vehicle.

Child Seat Anchor

The three-abreast seat in 2nd row of the vehicle has 4 ISOFIX standard interfaces, and there are also 3 TOP TETHER interfaces on the seat back panel. The individual seat in 2nd row has 2 ISOFIX standard interfaces, and there is also a TOP TETHER interface on the seat back panel. Please observe the instructions provided by the child seat manufacturer for removal and installation.

Installation Methods for Child Seats

- 1 Route the top tether strap over the seatback and attach to the corresponding child restraint anchorage hook, being careful not to twist the strap. When securing, you must make sure that the top strap passes through the seat headrest(This step only applies to those models with TOP TETHER

anchorage). Unless using ISOFIX lower anchorages, use the seatbelt complete the installation in line with the child restraint manufactures instructions.

- 2 Insert the child seat into the ISOFIX retaining ring until it is engaged reliably, the heard "click" sound indicates that it is installed in place.
- 3 When ISOFIX is correctly connected, press down the child seat with your body and tighten the ISOFIX tether to fix the seat firmly on the vehicle.

Caution

It would be best to fix the infant or child restraint device on the rear seat. If the infant or child restraint device must be placed on the front seat when driving, you must use the forward-facing infant or child restraint device. The infant or child restraint device must be fixed correctly regardless of its installation position. Keep in your mind that if the infant or child restraint device is not fixed, it may move and hurt other passengers in the vehicle in the event of collision or sudden braking. Therefore, all infant or child restraint devices must be properly secured in the vehicle even there are no infants or children sitting inside.

Before You Drive

Type I of 2nd row seat

Front of vehicle

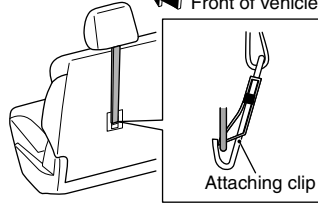
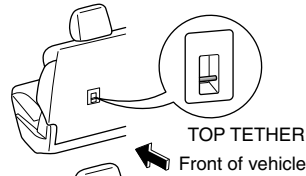
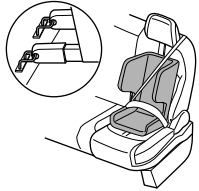
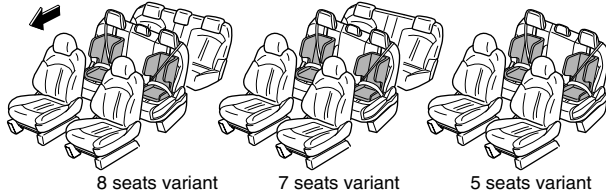

Type II of 2nd row seat

Front of vehicle

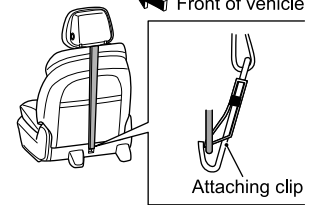
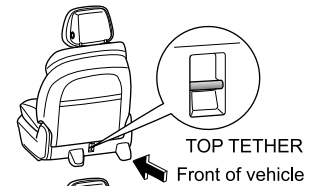
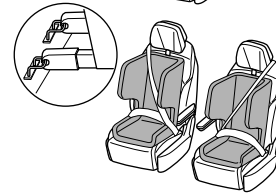
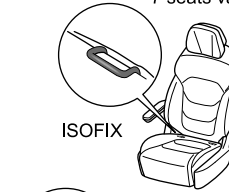
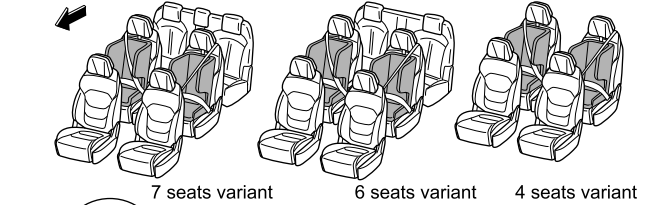

Before You Drive

Child seat groups and installation positions

Only the child restraints which are approved and suitable for children are allowed to use. Children above 1.5m in height can directly use the seat belt. The child seats shall comply with relevant regulations or standards, such as European regulations ECE-R44, ECE-R129, and Chinese regulations GB27887-2011.

Applicability of child restraints in different seating positions

Mass Group	Seating Position			
	First-row	Second-row Left	Second-row Right	Third-row
0 Group (Less than 10kg)	X	U	U	X
0+ Group (Less than 13kg)	X	U	U	X
I Group (9 ~ 18kg)	X	U	U	X
II Group (15 ~ 25kg)	X	U	U	X
III Group (22 ~ 36kg)	X	U	U	X

Note: The letter filled in the table means

U = Universal child restraint systems which have obtained the approval for this mass group are applicable.

X = Child restraint systems for this mass group are not applicable in this seating position.

Before You Drive

Adaptability of ISOFIX child restraints in different ISOFIX positions

Mass Group	Size Categories	Fixed Module	ISOFIX Positions on the Vehicle			
			First-row	Second-row Left	Second-row Right	Third-row
Portable Bed	F	ISO/L1	Without ISOFIX Device	IL	IL	Without ISOFIX Device
	G	ISO/L2		IL	IL	
0 Group (Less than 10kg)	E	ISO/ R1		IL	IL	
	E	ISO/R1		IL	IL	
0+ Group (Less than 13kg)	D	ISO/R2		IL	IL	
	C	ISO/R3		IL	IL	
	D	ISO/R2		IL	IL	
I Group (9 ~ 18kg)	C	ISO/R3		IL	IL	
	B	ISO/F2		IUF	IUF	
	B1	ISO/F2X		IUF	IUF	
	A	ISO/F3	IUF	IUF		
	A	ISO/F3	IUF	IUF		

Note: The letter filled in the table means

IUF = Forward-facing universal ISOFIX child restraint systems which have obtained the approval for this mass group are applicable.

IL = Special ISOFIX child restraint systems on the list are applicable. These restraint systems could be special vehicle type, restricted type or semi-universal type.

Note: For universal and semi-universal child seats, the ISOFIX size categories can be divided into Grade A to G, these classification information can be found on the ISOFIX child seats. The ISOFIX child seats currently recommended for Group 0+ is Britax Romer Baby Safe Plus. The ISOFIX child seats currently recommended for Group I is Britax Romer Duo Plus.

Note: The ISOFIX child seats currently recommended for Group II-III is KidFix XP.

Before You Drive

Instruments and Controls

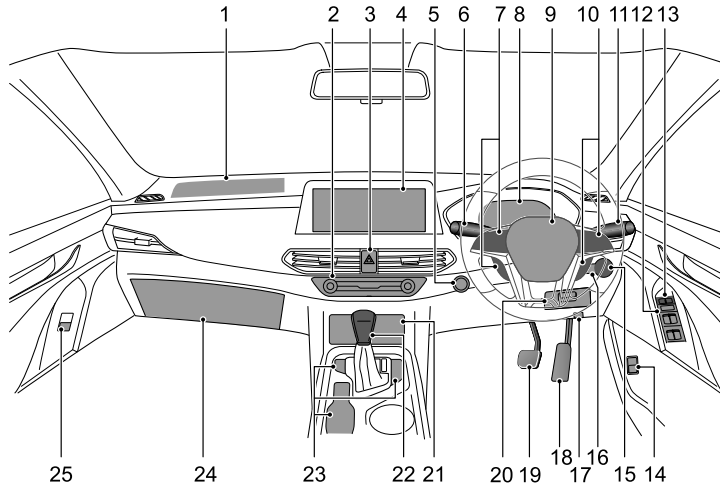

- 1 Front passenger airbag
- 2 A/C control panel
- 3 Hazard warning lamp switch
- 4 Entertainment system
- 5 Ignition switch
- 6 Wiper & washer stalk switch
- 7 Instrument cluster selection and cruise switch
- 8 Instrument pack
- 9 Driver airbag
- 10 Voice control, Bluetooth phone, steering wheel heating and customized switch
- 11 Combination lamp control & direction indicator lamp stalk switch
- 12 Door window control switches
- 13 Central lock switch
- 14 Fuel filler flap release switch
- 15 Exterior rearview mirror power adjustment switch
- 16 Headlamp leveling switch, instrument panel illumination control switch
- 17 Hood release
- 18 Accelerator pedal
- 19 Brake pedal
- 20 Storage compartment
- 21 Storage compartment
- 22 Shift lever
- 23 Floor console switches
- 24 Glove box
- 25 Front passenger door and window control switch

Before You Drive

Instrument Cluster

Instrument cluster type I

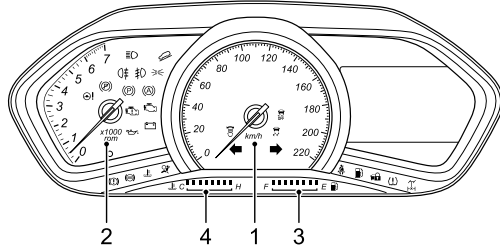

Instrument cluster type II

Trip computer interface

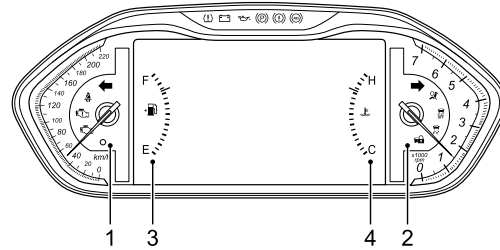

Other interfaces

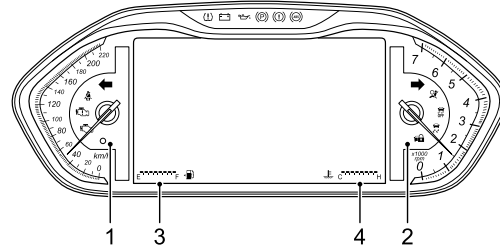

Before You Drive

- 1 Speedometer
- 2 Tachometer
- 3 Fuel gauge
- 4 Engine coolant temperature gauge

Caution

Do not place any objects in front of the instrument cluster, so as not to obstruct the dial and warning lamps.

Speedometer

The speedometer displays the vehicle speed in kilometers per hour (km/h).

Tachometer

The tachometer indicates the engine speed in revolutions per minute (x1000).

Caution

Never allow the pointer to remain in the red sector of the gauge for prolonged periods, otherwise the engine may be damaged.

Fuel gauge

Indicates the approximate amount of fuel in the fuel tank. When the "Low Fuel Warning Lamp (yellow)" does not go out or illuminate, please refuel as soon as possible.

Engine coolant temperature gauge

Indicates the approximate temperature of the engine coolant. If the coolant overheats, the "Engine Coolant Temperature Warning Lamp (red)" will illuminate.

Caution

If the red warning lamp illuminates, stop the engine as soon as possible to cool the coolant. Check the engine cooling system.

Caution

For vehicles with diesel engine, if low coolant level warning function is available, when the coolant level is too low, the red warning lamp will come on, accompanied with an audible alarm. Please stop the vehicle as soon as possible when the safety permits, turn off the engine and contact Service Dealer to check the engine cooling system.

Information Center

Information center type I

The information center display is located at the right side of the instrument cluster.

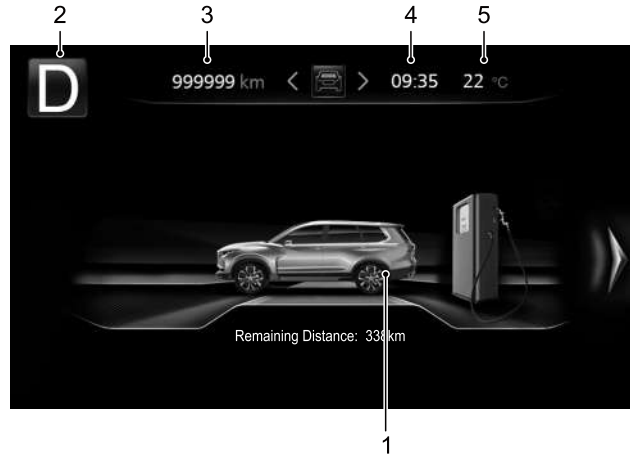

- 1 Trip computer interface
- 2 Gear display
- 3 Total mileage
- 4 Current time
- 5 Ambient temperature

Short press the ◀ or ▶ button in the instrument cluster selection



switch on the steering wheel to achieve the switching of following interfaces: Trip Computer interface→Active Safety interface(when your vehicle is equipped with this function)→Settings interface→Failure Inquiry interface (if a failure is available)→Trip Computer interface.

Trip computer interface

Short press the ▲ or ▼ button in the instrument cluster selection



switch on the steering wheel to achieve the switching of following interfaces:

- Driving mileage

This function automatically calculates and displays the remaining driving mileage for the vehicle before the fuel is used up. The mileage will change correspondingly after refueling.

- Instantaneous fuel consumption

This function automatically displays the instantaneous fuel consumption of currently operating engine.

- Digital vehicle speed

It displays the current speed.

- Since the startup

Displays the trip, average speed, driving time, average fuel consumption since the ignition switch is turned on.

Before You Drive

- Since the reset

Displays the trip, average speed, driving time, average fuel consumption since the last reset.

Long press the OK button in this interface to reset the trip, average speed, driving time and average fuel consumption.

- Tire pressure monitoring

In normal mode, it displays the current tire pressure in real time.

Note: *For vehicles equipped with tire pressure monitoring system, after the tires are inflated or deflated in static state, when the inflation and deflation is greater than 8kPa, the tire pressure information display value on the instrument cluster will be updated automatically.*

- Battery voltage

Displays current voltage of battery.

- Mileage to next maintenance

This message reminds you of the remaining mileage of your vehicle before the next maintenance.

Settings interface

Short press the ▲ or ▼ button in the instrument cluster selection



switch on the steering wheel to achieve the switching of following interfaces:

- Backlight brightness

You can set the instrument cluster display brightness.

- Time setting

You can set the time on the instrument cluster.

- Time format

You can set the time on the instrument cluster in 12 hour time format or 24 hour time format.

- Language setting (if equipped)

You can set the language based on the actual configuration.

- Overspeed alarm (if equipped)

You can turn on and off the overspeed alarm. When the overspeed alarm is turned on, the overspeed alarm triggering speed value can be adjusted.

Failure inquiry interface

You can inquire the relevant vehicle alarm and failure information in this interface.

Before You Drive

Information center type II

The information center display screen is located in the middle of instrument cluster.

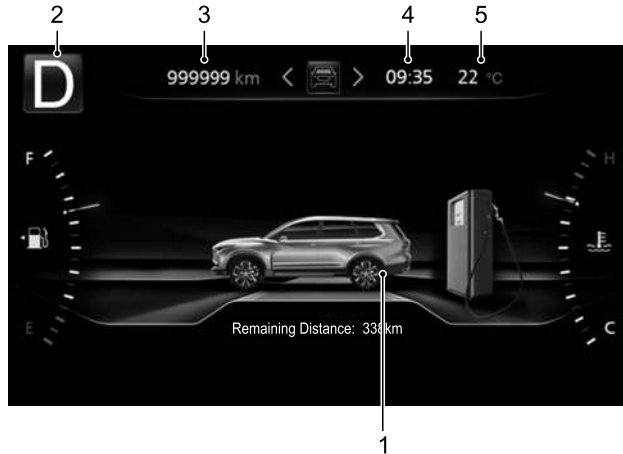

- 1 Trip computer interface
- 2 Gear display
- 3 Total mileage
- 4 Current time
- 5 Ambient temperature

Short press the < or > button in the instrument cluster selection

switch  on the steering wheel to achieve the switching

of following interfaces: Trip Computer interface→Navigation Map interface(when your vehicle is equipped with this function)→Multimedia interface→Contacts interface→Active Safety interface(when your vehicle is equipped with this function)→Settings interface→Failure Inquiry interface (if a failure is available)→Trip Computer interface.

Trip computer interface

Short press the ▲ or ▼ button in the instrument cluster selection

switch  on the steering wheel to achieve the switching of following interfaces:

- Driving mileage

This function automatically calculates and displays the remaining driving mileage for the vehicle before the fuel is used up. The mileage will change correspondingly after refueling.

- Instantaneous fuel consumption

This function automatically displays the instantaneous fuel consumption of currently operating engine.

- Digital vehicle speed

It displays the current speed.

- Since the startup

Displays the trip, average speed, driving time, average fuel consumption since the ignition switch is turned on.

- Since the reset

Before You Drive

Displays the trip, average speed, driving time, average fuel consumption since the last reset.

Long press the OK button in this interface to reset the trip, average speed, driving time and average fuel consumption.

- Tire pressure monitoring

In normal mode, it displays the current tire pressure in real time.

Note: *For vehicles equipped with tire pressure monitoring system, after the tires are inflated or deflated in static state, when the inflation and deflation is greater than 8kPa, the tire pressure information display value on the instrument cluster will be updated automatically.*

- Battery voltage

Displays current voltage of battery.

- Mileage to next maintenance

This message reminds you of the remaining mileage of your vehicle before the next maintenance.

Navigation map interface

It displays the current navigation information.

Multimedia interface

It displays the current listening music/radio program information.

Contacts interface



It displays the contacts information.

Active safety interface

It displays the relevant driver assistant information.

- Adaptive cruise
- Lane departure
- Lane keeping
- Emergency brake
- Traffic signs
- Automatic parking

Settings interface

Short press the  or  button in the instrument cluster selection



switch  on the steering wheel to achieve the switching of following interfaces:

- Backlight brightness

You can set the instrument cluster display brightness.

- Time setting

You can set the time on the instrument cluster.

- Time format

You can set the time on the instrument cluster in 12 hour time format or 24 hour time format.

- Language setting (if equipped)

You can set the language based on the actual configuration.

- Overspeed alarm (if equipped)

You can turn on and off the overspeed alarm. When the overspeed alarm is turned on, the overspeed alarm triggering speed value can be adjusted.

- Display theme (if equipped)

You can set the instrument cluster theme: comfort/sports.

Failure inquiry interface

You can inquire the relevant vehicle alarm and failure information in this interface.

Alarm messages

Most of the alarm messages will have a corresponding graphic and text description on the instrument cluster. When the message is displayed, the alarm indicator will also illuminate.

If more than one alarm message is activated, the display will show them circularly in the priority sequence, each message will be displayed for 3 seconds.

The priority of alarm messages is higher than that of trip computer information, after the one-touch start switch is turned on, the alarm messages will be displayed first.

Please operate in strict accordance with the instructions in the alarm message, if no relevant instruction is available, please stop the vehicle to check, or consult our Service Dealer.

Important alarm messages

For the currently displayed important alarm message, it can be temporarily hidden by short pressing the OK button on the steering wheel or will be automatically hidden after 9 seconds, if the alarm is not canceled, you can view it in the alarm inquiry interface.

If all alarm messages are hidden, the trip computer information will be normally displayed.

After the alarm is canceled, its corresponding alarm message will be canceled at the same time.

Before You Drive

Prompt messages

Prompt messages will automatically disappear after 3 seconds.

Caution

Do not ignore the alarm messages, or severe damage to the vehicle may occur. If an alarm indicator illuminates, stop the vehicle as soon as possible while ensuring the safety.

Fatigue driving detection and reminder

! **Fatigue driving detection and reminder function is to remind drivers not to drive the vehicle at the time of fatigue. The system will record the continuous driving time, while monitoring the steering wheel input in real-time, to identify whether the driver needs to rest.**

Fatigue reminder

- During the driving, when the system detects that the steering wheel rotation law meets the fatigue driving conditions, the instrument cluster display will display the following interface, accompanied with voice prompts.



It indicates that the system suggests the driver to take a break, please stop the vehicle for a rest.

- During the driving, when the system detects that the continuous driving time exceeds 2 hours and the vehicle

Before You Drive

1

speed is higher than 65km/h, the instrument cluster display will display the following interface, accompanied with voice prompts.



It indicates that the system suggests the driver to take a break, please stop the vehicle for a rest.

Caution

- Do not drive the vehicle at the time of fatigue. A driver is always responsible for his driving competence.
- In a long time driving, enough rest needs to be taken at a regular basis.
- The system cannot identify the needs for rest in all cases.

Tire pressure monitoring system

The tire pressure monitoring system can conduct real-time automatic monitoring on the tire conditions, providing an effective safety assurance for driving.

During the driving, when insufficient pressure, excessive pressure, rapid air leakage occur on the tires or the system fails, the "Tire Pressure Monitoring System Warning Lamp (yellow)"



on the instrument cluster will illuminate, accompanied with voice prompts, and the instrument cluster display will display the alarm interface.

Before You Drive

Warning Lamps and Indicators

Direction Indicator



The right or left "direction indicator (green)" blinks when making a turn. The right and left direction indicators blink simultaneously when the hazard warning lamp switch is pressed.

Note: *If either direction indicator is blinking quickly, this indicates that the bulb of turning signal lamp on this side is faulty.*

Front Fog Lamp Indicator



"Front Fog Lamp Indicator (green)" illuminates when the front fog lamp is turned on.

Headlamp High Beam Indicator



If the headlamp high beam is turned on or the headlamp is blinking, "Headlamp High Beam Indicator (blue)" illuminates.

Rear Fog Lamp Indicator



"Rear Fog Lamp Indicator (yellow)" illuminates when the rear fog lamp is turned on.

Position Lamp Indicator



"Position Lamp Indicator (green)" illuminates when the position lamp is turned on.

AFS (Adaptive Front Lighting System) Warning Lamp



When the ignition switch is turned to the ON position, if the "AFS warning lamp (yellow)" stays on, or illuminates during driving, it indicates that the AFS system or headlamp high beam, low beam has a malfunction, please contact our Service Dealer for service as soon as possible.

Airbag Warning Lamp



When the ignition switch is turned to the ON position, "Airbag Warning Lamp (red)" is turned on, the system conducts the self-check and the lamp goes off after several seconds.

If this warning lamp does not illuminate or blinks, stays on, or illuminates or blinks during driving, it indicates that the SRS has

a malfunction. Please contact our Service Dealer for service as soon as possible.

Refer to "Airbags" in this section for more information.

Driver and Front Passenger Seat Belt Warning Lamp



When the ignition switch is placed in ON position, "Driver and Front Passenger Seat Belt Warning Lamp (red)" illuminates, the system conducts the self-check and the lamp goes off after several seconds. When the driver or front passenger seat belt is not properly fastened, the "Driver and Front Passenger Seat Belt Warning Lamp (red)" illuminates. When the vehicle speed is greater than 20km/h, the audible warning "seat belt unfastened" will sound, meanwhile the "Driver and Front Passenger Seat Belt Warning Lamp (red)" blinks. After the seat belt is fastened, the "Driver and Front Passenger Seat Belt Warning Lamp (red)" goes out, and the audible warning stops.

Rear Seat Belt Warning Lamp



When the ignition switch is placed in ON position, if the "Rear Seat Belt Warning Lamp (yellow)" is on for a short time, it indicates that the rear seat belt is not properly secured, please fasten your seat belt. When the vehicle speed is higher than 25km/h, the "Rear Seat Belt Warning Lamp (yellow)" is on for

a short time or flash for a short time and sound a warning, it indicates that the rear seat belt is not properly secured, please fasten your seat belt.

Brake System Warning Lamp



When the ignition switch is turned to the ON position, if the parking brake is applied, "Brake System Warning Lamp (red)" illuminates, it will go off once the parking brake is released completely.

When the brake fluid level is below the normal range, "Brake System Warning Lamp (red)" will also illuminate.

If the warning lamp stays on when the parking brake is released, it indicates that the brake system is faulty, stop the vehicle immediately, and contact Service Dealer for service as soon as possible.

If your vehicle is equipped with Electronic Brake Force Distribution (EBD) system, when the ignition switch is placed in ON position, the "Brake System Warning Lamp (red)" illuminates, the system conducts the self-check and the lamp goes out after several seconds. If the warning lamp stays on or illuminates during driving, it indicates that the brake system has a malfunction, please contact Service Dealer for service as soon as possible.

ABS (Anti-lock Brake System) Warning Lamp



When the ignition switch is turned to the ON position, "ABS warning lamp (yellow)" illuminates, the system conducts the self-check and the lamp goes off after several seconds.

If the warning lamp stays on or illuminates while driving, it indicates that the ABS has a malfunction, please contact Service Dealer for service as soon as possible.

Note: Even if the ABS is faulty, the brake system can still be used for braking (ABS is disabled at this time). Please Refer to "Brake System" in the Starting and Driving section for more information.

EBD (Electronic Brake Force Distribution) Warning Lamp



When the ignition switch is turned to the ON position, "EBD warning lamp (red)" illuminates, the system conducts the self-check and the lamp goes off after several seconds.

If the warning lamp stays on or illuminates during driving, it indicates that the brake system has a malfunction, please contact Service Dealer for service as soon as possible.

ESP (Electronic Stability Program) Indicator Lamp



When the ignition switch is turned to the ON position, "ESP Indicator Lamp (yellow)" illuminates, the system conducts the self-check and the lamp goes off after several seconds.

"ESP Indicator Lamp (yellow)" blinks when the electronic stability program is operating.

If the warning lamp remains on, it indicates that the electric stability program has a malfunction, please contact Service Dealer for service as soon as possible. Please Refer to "Brake System" in the Starting and Driving section for more information.

ESP (Electronic Stability Program) OFF Indicator Lamp



When the ignition switch is placed in ON position, the "ESP OFF Indicator Lamp (yellow)" illuminates, the system conducts the self-check and the lamp goes out after several seconds.

When the ESP OFF switch is pressed and the ESP is turned off, "ESP OFF Indicator Lamp (yellow)" illuminates. Please Refer to "Floor Console Switches" in this section for more information.

Hill Descent Indicator Lamp



When the Hill Descent is turned on and the operating conditions are met, the "Hill Descent Indicator Lamp (green)" blinks. Refer to "Floor Console Switches" in this chapter for information on the hill descent switch. If the Hill Descent system fails, the "Hill Descent Indicator Lamp (yellow)" illuminates. Please Refer to "Brake System" in the Starting and Driving section for more information.

Engine Malfunction Warning Lamp



When the ignition switch is turned to the ON position, "Engine Malfunction Warning Lamp (yellow)" illuminates, the system conducts the self-check and the lamp goes off after several seconds.

If the warning lamp illuminates, it indicates that the engine-related parts are faulty. Please contact our Service Dealer for service as soon as possible.

Emission MIL



When the ignition switch is turned to the ON position, "Emission MIL (yellow)" illuminates, and goes off after the engine is started. If the warning lamp illuminates, it indicates that the engine performance and the emission system are faulty.

Please contact Service Dealer for service as soon as possible, meanwhile, avoid the too high engine speed or fast acceleration.

Oil Pressure Warning Lamp



When the ignition switch is turned to the ON position, "Oil Pressure Warning Lamp (red)" illuminates, the system conducts the self-check and the lamp goes off after several seconds. After the engine is started or during the driving, the "Oil Pressure Warning Lamp (red)" illuminates, it indicates that the oil pressure is faulty, please shut down the engine immediately and check the oil level. Refer to "Engine Oil" in the Maintenance and Service chapter.

Caution
Even if the oil level is normal, do not restart the engine, please contact Service Dealer for service as soon as possible.

Engine Immobiliser Warning Lamp



When the ignition switch is turned to the ON position, "Engine Immobiliser Warning Lamp (yellow)" illuminates, the system conducts the self-check and the lamp goes off after several seconds. If the engine immobiliser is authenticated successfully, "Engine Immobiliser Warning Lamp (yellow)" remains dark and the engine can be started.

Before You Drive

If the "Engine Immobiliser Warning Lamp (yellow)" blinks, it indicates that the immobiliser control system has a malfunction, the engine can not be started, please contact Service Dealer for service immediately.

Body Theft Deterrent Warning Lamp



When the vehicle is in the armed state, "Body Theft Deterrent Warning Lamp (red)" blinks.

When the vehicle is out of the armed state, "Body Theft Deterrent Warning Lamp (red)" goes off.

If the theft deterrent alarm is triggered, the "Body Theft Deterrent Warning Lamp (red)" blinks, accompanied with audible and visible alarm.

Tire Pressure Monitoring System Warning Lamp



When the ignition switch is turned to the ON position, "Tire Pressure Monitoring System Warning Lamp (yellow)" illuminates, the system conducts the self-check and goes off after several seconds. When the tire pressure monitoring system has a malfunction, "Tire Pressure Monitoring System Warning Lamp (yellow)" illuminates, please contact Service Dealer for service as soon as possible.

Battery Charging Indicator Lamp



When the ignition switch is turned to the ON position, "Battery Charging Indicator Lamp (red)" illuminates, and goes off after the engine is started.

Caution

If the warning lamp stays on after the engine is started or illuminates during driving, it indicates that the charging system has a malfunction, please contact Service Dealer for service as soon as possible.

Constant Speed Cruise Indicator Lamp



With the ignition switch placed in ON position, when the cruise system is in standby state, the "Constant Speed Cruise Indicator Lamp (white)" illuminates, when the system is in activation state, the "Constant Speed Cruise Indicator Lamp (green)" illuminates. Please Refer to "Constant Speed Cruise Control System" in the Starting and Driving section for more information.

Adaptive Cruise Control Indicator Lamp



With the ignition switch placed in ON position, turn on the adaptive cruise, when the adaptive cruise system meets the activation conditions, the "Adaptive Cruise Control (ACC)

Indicator Lamp (green)" illuminates. When the adaptive cruise control system is in standby mode, the "Adaptive Cruise Control (ACC) Indicator Lamp" on the instrument cluster will change from green to white. Please Refer to "Driver Assistant System" in the Starting and Driving section for more information.

Adaptive Cruise Vehicle-to-Vehicle Distance Indicator Lamp



With the ignition switch placed in ON position, turn on the adaptive cruise, when setting the vehicle-to-vehicle distance, the "Adaptive Cruise Vehicle-to-Vehicle Distance Indicator Lamp (yellow)" illuminates. Please Refer to "Driver Assistant System" in the Starting and Driving section for more information.

4WD Malfunction Warning Lamp



When the ignition switch is turned to the ON position, "4WD Malfunction Warning Lamp (red)" illuminates or illuminates during driving, it indicates that the 4WD system has a malfunction, please contact Service Dealer for service as soon as possible. Please Refer to "Four Wheel Drive (4WD)" in the Starting and Driving section for more information.

Lane Departure Alert Warning Lamp



With the ignition switch placed in ON position, when the lane departure alert is in standby state, the "Lane Departure Alert Warning Lamp (white)" illuminates.

When the lane departure alert is in operating state, the "Lane Departure Alert Warning Lamp (green)" illuminates.

When the lane keeping assist is in operating state, the "Lane Departure Alert Warning Lamp (blue)" illuminates.

When the lane departure alert is in operating state and gives an alarm, the "Lane Departure Alert Warning Lamp (yellow)" blinks.

When the lane departure alert is in off state or has a malfunction, the "Lane Departure Alert Warning Lamp (yellow)" illuminates.

If the warning lamp illuminates yellow when the lane departure alert is on, it indicates that the lane departure alert has a malfunction, please contact our Service Dealer for service as soon as possible. Please Refer to "Driver Assistant System" in the Starting and Driving section for more information.

Intelligent Start/Stop System Indicator Lamp



With the ignition switch placed in ON position, turn on the start/stop system, when the start/stop

Before You Drive

conditions are not met, the "Intelligent Start/Stop System

Indicator Lamp (white)"  illuminates.

With the ignition switch placed in ON position, turn on the start/stop system, when the engine automatically stops, the

"Intelligent Start/Stop System Indicator Lamp (green)"  illuminates.

With the ignition switch placed in ON position, turn on the start/stop system, when the start/stop system has a malfunction, the "Intelligent Start/Stop System Indicator Lamp (yellow)"

 illuminates.

Please Refer to "Intelligent Start/Stop System" in the Starting and Driving section for more information.

AUTO HOLD Indicator Lamp

 With the ignition switch placed in ON position, turn on the AUTO HOLD, the "AUTO HOLD Indicator Lamp (green)" illuminates; when the AUTO HOLD is activated, the "AUTO HOLD Indicator Lamp (green)" blinks.

AUTO HOLD has the memory capability. When the AUTO HOLD is on, after the driver unbuckles the seat belt, the "AUTO HOLD Indicator Lamp (green)" goes out, but the On state is still memorized by the AUTO HOLD system. When the AUTO

HOLD is on, the vehicle speed exceeds 3 km/h and the seat belt is not fastened, the "AUTO HOLD Indicator Lamp (green)" illuminates to remind the driver that the AUTO HOLD On state has been recalled, and the AUTO HOLD can be activated just by fastening the seat belt again. When the AUTO HOLD is on, the vehicle speed is lower than 3 km/h and the seat belt is not fastened, the AUTO HOLD cannot be activated due to unfastened seat belt, and the "AUTO HOLD Indicator Lamp (green)" goes out.

With the ignition switch placed in ON position, turn on the AUTO HOLD, when the AUTO HOLD has a malfunction, the "AUTO HOLD Indicator Lamp (yellow)" illuminates.

Please Refer to "Brake System" in the Starting and Driving section for more information.

Electronic Parking Brake (EPB) Indicator Lamp

 With the ignition switch placed in ON position, turn on the electronic parking brake, when the parking brake is applied, the "EPB Indicator Lamp (red)" illuminates, and goes out immediately after the parking brake is fully released.

Please Refer to "Brake System" in the Starting and Driving section for more information.

Electronic Parking Brake (EPB) Malfunction Indicator Lamp



When the ignition switch is turned to the ON position, "EPB Malfunction Indicator Lamp (yellow)" illuminates, the system conducts the self-check and the lamp goes off after several seconds. If the "EPB Malfunction Indicator Lamp (yellow)" illuminates after the electronic parking brake is released, it indicates that the brake system has a malfunction, please stop the vehicle immediately, and contact our Service Dealer for service as soon as possible.

Please Refer to "Brake System" in the Starting and Driving section for more information.

Electric Power Steering (EPS) System Failure Warning Lamp



With the ignition switch placed in ON position, the "EPS System Failure Warning Lamp (red)" illuminates, it indicates that the EPS system has a malfunction, please stop the vehicle immediately, and contact our Service Dealer for service as soon as possible.

Front Collision Warning (FCW)/Automatic Emergency Braking (AEB) Warning Lamp



With the ignition switch placed in ON position, when the front collision warning system is operative, and the automatic emergency braking warning system does not give a warning, the "FCW/AEB Warning Lamp (yellow)" blinks; with the ignition switch placed in ON position, when the automatic emergency braking warning system gives a warning, the "FCW/AEB Warning Lamp (red)" illuminates. Please Refer to "Driver Assistant System" in the Starting and Driving section for more information.

Ahead Vehicle Indicator Lamp



With the ignition switch placed in ON position, when any of the ACC/FCW/AEB is turned on, and a vehicle within the front monitoring distance is detected, the "Ahead Vehicle Indicator Lamp (green)" illuminates. Please Refer to "Driver Assistant System" in the Starting and Driving section for more information.

Electronic Differential Lock Indicator Lamp

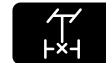

With the ignition switch placed in ON position, press the differential lock switch, when the electronic differential lock

Before You Drive

is successfully locked, the "Electronic Differential Lock Indicator Lamp (yellow)" illuminates.

With the ignition switch placed in ON position, the "Electronic Differential Lock Indicator Lamp (red)" illuminates, it indicates that the electronic differential lock system has a malfunction, please stop the vehicle immediately, and contact our Service Dealer for service as soon as possible. Please Refer to "Electronic Differential Lock (EDL)" in the Starting and Driving section for more information.



Traffic Signs Warning Lamp



With the ignition switch placed in ON position, when a speed limit sign is detected, the "Traffic Signs Warning Lamp (white)" illuminates. Please Refer to "Driver Assistant System" in the Starting and Driving section for more information.



ECO Indicator Lamp



Turn the ignition switch to ON position. For models with the ECO mode switch, press the ECO switch, "ECO Indicator Lamp (green)" turns on; for models with the driving mode switch , press the  switch once, and the "ECO Indicator Lamp (green)" turns on.

SPORT Indicator Lamp



Turn the ignition switch to ON position. For models with the SPORT mode switch, press the SPORT switch, "SPORT Indicator Lamp (green)" turns on; for models with the driving mode switch , press the  switch twice, and the "SPORT Indicator Lamp (green)" turns on.

Fuel Filter Water Level Warning Lamp

Note: It applies to vehicles equipped with diesel engine.



When the ignition switch is turned to the ON position, if the "Fuel Filter Water Level Warning Lamp (yellow)" illuminates during driving, stop the vehicle as soon as possible and drain the water from the fuel filter. If not the engine will limit torque. Refer to "Water Draining of Fuel Filter" in the Treatments to Emergency Fault for the information on the water draining of the fuel filter.

Glow Plug Indicator

Note: It applies to vehicles equipped with diesel engine.



When the ignition switch is turned to the ON position, if the "Glow Plug Indicator (yellow)" goes off when the preset time elapsed, it indicates that the engine can be started.

Before You Drive

Caution

If the indicator stays on after the engine is started, please contact Service Dealer for service as soon as possible.

DPF (Diesel Particulate Filter) Warning Lamp

Note: *It applies to models equipped with the diesel engine.*



Turn the ignition switch to ON position. When the "DPF Warning Lamp (yellow)" is always on, Level 1 alarm of the diesel particulate filter is prompted, indicating that the DPF tends to be overloaded. Drive the vehicle at high speed (vehicle speed more than 60 km/h) for about 20 minutes when safe and legal, or stop it in a safe environment and press the DPF one-touch regeneration switch in the armrest box for regeneration in situ; when the DPF warning lamp flashes, Level 2 alarm of the diesel particulate filter is prompted, indicating that the particulate filter is clogged and automatic regeneration cannot be performed. Please stop the vehicle in a safe environment and press the DPF one-touch regeneration switch in the armrest box for regeneration in situ. Refer to "Catalytic Converter" in "Starting & Driving" section for details.

Instrument Panel Switch

Instrument panel illumination control switch

The instrument panel illumination control switch is located on the instrument panel at driver side.

1

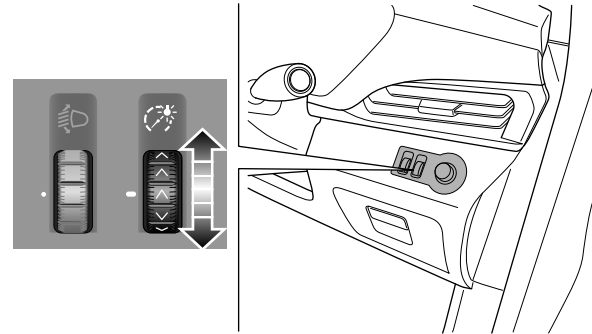

Adjust the instrument panel illumination brightness with the instrument panel illumination control thumbwheel switch .

Move the thumbwheel switch  up/down to brighten or dim the illumination lamp.

Before You Drive

Headlamp leveling switch

The headlamp leveling switch is located on the instrument panel at driver side.

With this function, the headlamp leveling can be adjusted to the condition suitable for vehicle and road. The correction of headlamp leveling can reduce the dazzling light to other drivers.

To adjust the headlamp leveling, headlamp low beam must be turned on.

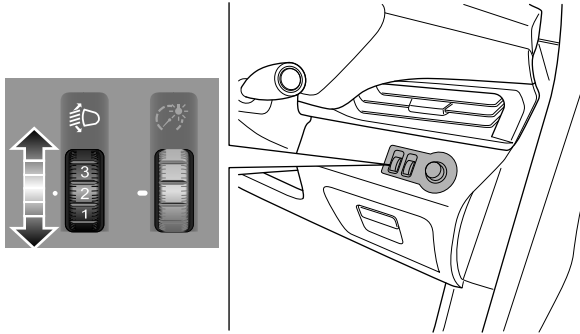

Adjust the headlamp leveling by moving the thumbwheel upwards or downwards. 0 position is the initial position, with the increase in vehicle load, please adjust the headlamp leveling in the sequence of 1-2-3 position.

Adaptive front-lighting System

If your vehicle is equipped with AFS (Adaptive Front-lighting System), the system automatically adjusts the headlamp beam height according to the driving speed, vehicle load and ramp angle.

When driving with passengers or luggages carried, the headlamp beams are automatically adjusted up or down.

Note: The headlamp aiming is very important for safe driving. If an adaptive front-lighting system failure occurs, please contact our Service Dealer for service as soon as possible.

Before You Drive

Hazard warning lamp switch

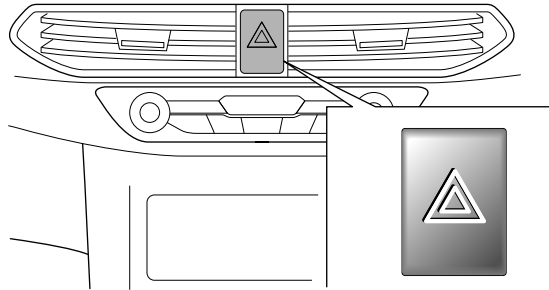

Press the hazard warning lamp switch  to activate all turning signal lamps meanwhile, and the "direction indicator lamp (green)" on the instrument cluster will illuminate and flash. Then press this switch to turn off the above lamps.

Note: *Turn on hazard warning lamps to prompt other vehicles that your vehicle has a malfunction and approaching your vehicle may be dangerous.*

Floor Console Switches

Switch group in left front side of the shift lever

1

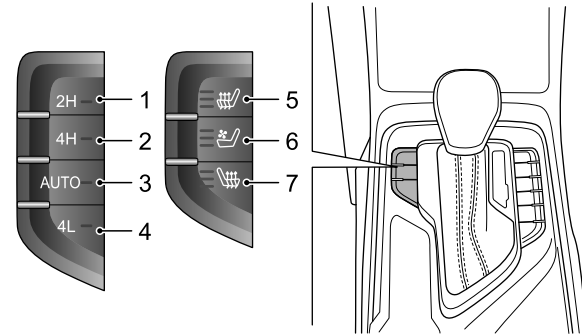

Position 1–2H: two wheel drive switch.

Position 2–4H: high-speed four wheel drive switch.

Position 3–AUTO: automatic mode switch.

Position 4–4L: low-speed four wheel drive switch.

Caution

The 4L mode can be selected only when the 4L switch is long pressed for more than 2 seconds.

Note: *When the vehicle is stopped and the clutch pedal is depressed, you can switch among 2H/4H/AUTO and 4L; press down the switch for about 5 seconds, the target*

Before You Drive

gear indicator lamp of the switch illuminates; for more information, please refer to "Four Wheel Drive (4WD)" in the Starting and Driving section.

Position 5—: driver seat heating. There are three gears for driver seat heating. Press down the switch (5) to start up the driver's seat heating; at the moment, the third heating gear (3 indicator lamps) will be engaged. Press down the switch (5) in turn to shift the driver's seat heating gear accordingly to the second heating gear (2 indicator lamps), the first heating gear (1 indicator lamp), and its function turnoff.

Position 6—: driver's seat ventilation. There are three gears for driver's seat ventilation. Press down the switch (6) to start up the driver's seat ventilation; at the moment, the third ventilation gear (3 indicator lamps) will be engaged. Press down the switch (6) in turn to shift the driver's seat ventilation gear accordingly to the second ventilation gear (2 indicator lamps), the first ventilation gear (1 indicator lamp), and its function turnoff.

Position 7—: passenger seat heating. There are three gears for passenger seat heating. Press down the switch (7) to start up the passenger seat heating; at the moment, the third heating gear (3 indicator lamps) will be engaged. Press down the switch (7) in turn to shift the passenger seat heating gear accordingly to the second heating gear (2 indicator lamps), the first heating gear (1 indicator lamp), and its function turnoff.

Switch group in left rear side of the shift lever

Type I

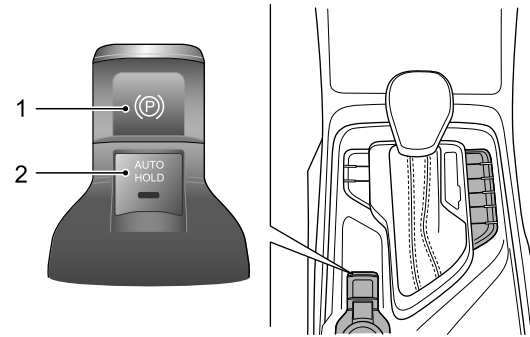

Position 1 – : EPB (electronic parking brake) switch.

Position 2 – : AUTO HOLD (auto-hold automatic parking) switch. Press down the button to light up its indicator lamp.

Note: Please refer to "Brake System" in the Starting and Driving section for more information.

Before You Drive

Type II

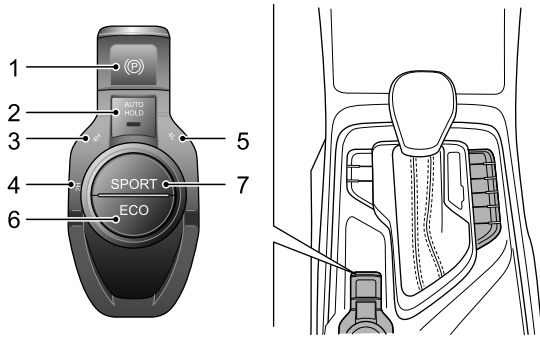

Position 1 – Ⓞ: EPB (electronic parking brake) switch.

Position 2 – AUTO HOLD: AUTO HOLD (auto-hold automatic parking) switch. Press down the button to light up its indicator lamp.

Note: Please refer to "Brake System" in the Starting and Driving section for more information.

Position 3–4H: high-speed four-wheel drive switch.

Position 4–2H: two-wheel drive switch.

Position 5–4L: low-speed four-wheel drive switch.

Note: Please refer to "Four Wheel Drive (4WD)" in the Starting and Driving section for more information.

Position 6–ECO: economic mode switch. Press down this switch to drive the vehicle under the economic mode, under which the engine power will be relatively weak. It is unable to enable the economic mode under the 4L mode.

Position 7–SPORT: sport mode switch. Press down this switch to drive the vehicle under the sport mode, under which the engine power will be relatively strong. It is unable to enable the sport mode under the 4L mode.

Type III

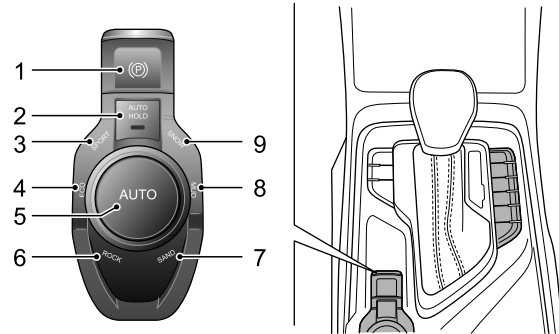

Position 1–Ⓞ: EPB (electronic parking brake) switch.

Position 2–AUTO HOLD: AUTO HOLD (auto-hold automatic parking) switch. Press down the button to light up its indicator lamp.

Note: Please refer to "Brake System" in the Starting and Driving section for more information.

Before You Drive

Position 3–SPORT: sport mode switch.

Position 4–ECO: economic mode switch.

Position 5–AUTO: automatic mode switch.

Position 6–ROCK: rock mode switch.

Position 7–SAND: sand mode switch.

Position 8–MUD: mud mode switch.

Position 9–SNOW: snow mode switch.

Note: Please refer to "Four Wheel Drive (4WD)" in the Starting and Driving section for more information.

Switch group in right side of the shift lever

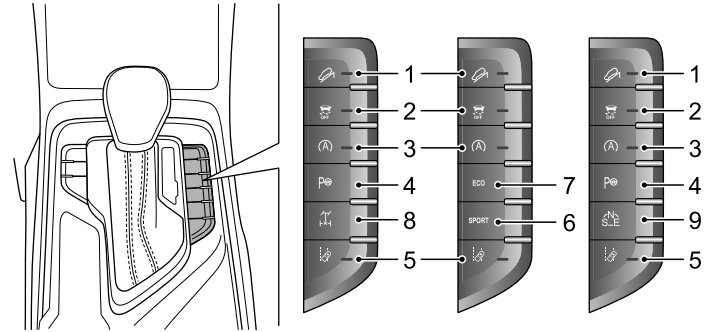

Position 1—: hill descent control switch. Press the switch (1), and the indicator lamp in the switch illuminates and the hill descent control function is enabled; press the switch (1) again to disable the function; for more information, please refer to "Brake System" in the Starting and Driving section.

Position 2—: ESP OFF switch. Press the switch (2), and the indicator lamp in the switch illuminates and the ESP system is turned off; press the switch again to enable the ESP system; after the ESP system is turned off, only ABS and EBD functions can work; for more information, please refer to "Brake System" in the Starting and Driving section.

Position 3—: engine intelligent start/stop system switch. With the ignition switch placed in ON position, the engine intelligent start/stop system will be turned on by default while the indicator lamp in the switch will light up. Press the switch (3) to go out

Before You Drive

its indicator lamp and turn off the engine intelligent start/stop system; re-press the switch to turn on the system. For more information, please refer to "Intelligent Start/Stop System" in the Starting and Driving section.

Position 4—: automatic parking switch.

Note: For more information, please refer to "Intelligent Semi-Automatic Parking Assist System" in the Starting and Driving section.





Position 5—: lane departure alert switch. With the ignition switch placed in ON position, the lane departure alert will be turned on by default while the indicator lamp in the switch will illuminate. Press down the switch to turn off the lane departure warning; and then the indicator lamp on the switch will go off while the "Lane Departure Alert Warning Lamp" on the combination instrument will be lightened in yellow. Re-press the button to enable the lane departure alert. For more information, please refer to "Driver Assist System" in the Starting and Driving section.

Position 6—SPORT: sport mode switch. Press down this switch to drive the vehicle under the sport mode, under which the engine power will be relatively strong.

Position 7—ECO: economic mode switch. Press down this switch to drive the vehicle under the economic mode, under which the engine power will be relatively weak.

Position 8—: electronic differential lock control switch. Use electronic differential lock control switch to select the differential

lock On/Off state with the EDL switch. Please refer to "Electronic Differential Lock (EDL)" in the Starting and Driving section for more details.

Position 9— : driving mode switch. When the  switch is pressed once, the vehicle is driven in the ECO mode, and the engine power is relatively weak; when the  switch is pressed twice, the vehicle is driven in the SPORT mode, and the engine power is relatively strong. When the  switch is pressed again, the vehicle returns to the normal mode.

Before You Drive

Switches on Steering Column and Steering Wheel

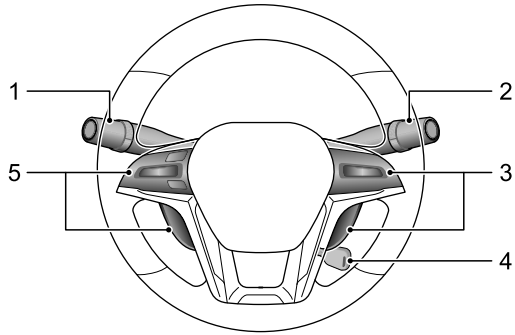

- 1 Wiper & washer stalk switch
- 2 Combination lamp control & direction indicator lamp stalk switch
- 3 Voice control, Bluetooth phone, steering wheel heating and customized switch
- 4 Ignition switch and steering lock
- 5 Instrument cluster selection and cruise switch

Ignition switch and steering lock

Pull out the key. Then the steering lock will be activated to prevent the steering wheel from rotating.



In order to pull out the key from the ignition switch, please turn the key to ACC position. Then press the key towards the ignition switch and continue rotating it to LOCK position. At this time, the key can be pulled out.

Note: If the key on the ignition switch is not pulled out, there will be warning sounds when the driver door is opened.

Please refer to "Ignition Switch" in the Starting and Driving section for more information about ignition switch positions.

Combination lamp control & direction indicator lamp stalk switch

Lighting control switch

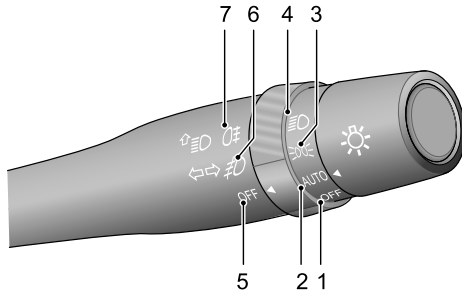

Shift the lighting control switch to the position as shown in the figure, and the corresponding lamps will illuminate.

Position 1 –OFF: Headlamps off. Daytime running lamps will automatically illuminate after the engine is started.

Position 2 –AUTO: Headlamp automatic adjustment. When the headlamp switch is placed in AUTO position, headlamps will illuminate/go off according to the lighting brightness of ambient environment. Daytime running lamps will automatically illuminate when other lamps are not turned on after the engine is started.

Note: Initial position of headlamp switch is suggested to AUTO position.





Position 3 – : Width lamps on. When width lamps are turned on, the following lamps will be turned on meanwhile:

- Width lamps
- License plate lamp
- Instrument panel lamp





Position 4 – : Headlamps on.

Note: Headlamps can be turned on only when the ignition switch is placed in ON position. If headlamps are not turned off when the vehicle is parked, battery will discharge. Then the engine may be unable to start due to low battery. When the ignition switch is placed in LOCK position or the key is pulled out, there will be warning sounds if the headlamp switch is still turned on.

Position 5 –OFF: fog lamp off.

Position 6 – : Front fog lamps on. When the ignition switch is placed in ON position and the lighting control switch is placed in  or  position, turn the switch to , and then front fog lamps will be turned on. When the lighting control switch is placed in AUTO position, and the switch is rotated to  position, the front fog lamps may illuminate and go out with the headlamp according to the ambient circumstances. When the front fog lamps are turned on, the "front fog lamp indicator lamp (green)" on the instrument cluster will illuminate.

Before You Drive

Position 7 – : Rear fog lamps on. When the ignition switch is placed in ON position and the lighting control switch is placed in  or  position, turn the switch to , and then rear fog lamps will be turned on. When the lighting control switch is placed in AUTO position, and the switch is rotated to  position, the rear fog lamps may illuminate and go out with the headlamp according to the ambient circumstances. When the rear fog lamps are turned on, the "rear fog lamp indicator lamp (yellow)" on the instrument cluster will illuminate.

Note: *Rear fog lamps shall not be used until the visibility is obviously restricted (such as heavy fog or snow).*

Turn signal lamps and direction indicator lamps

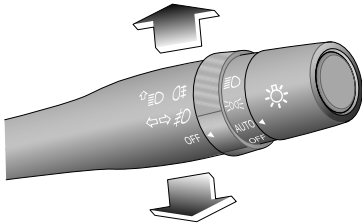

Turn right – push the stalk switch downwards.

Turn left – pull the stalk switch upwards.

Then the corresponding turn signal lamp and the "direction indicator lamp (green)" on the instrument cluster will illuminate simultaneously.

High beam and low beam lamps

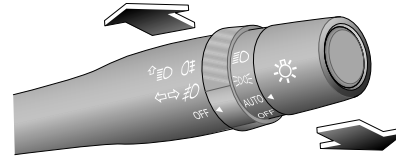

Push the stalk switch away from the steering wheel to change the headlamp mode from low beam to high beam. Pull the stalk switch close to the steering wheel to change the headlamp mode to low beam.

Note: *When the headlamp mode is high beam, the "headlamp high beam indicator lamp (blue)" on the instrument cluster will illuminate. To shift the headlamp mode to flashing, slightly lift the stalk switch towards the steering wheel intermittently.*

Before You Drive

Daytime running lamp

The daytime running lamp make it easier for others to see the front of the vehicle during the daytime.

If your vehicle is equipped with the daytime running lamp, when the ignition switch is placed in ON position, the daytime running lamp will illuminate. When the daytime running lamp illuminates, the low beam, tail lamp, position lamp and other lamps will not illuminate. When the ignition switch is in OFF position, the daytime running lamp will go out.

It is in line with the requirements in ECE R87 for daytime running lamp.

Wiper & washer stalk switch

Front windshield wipers and washer

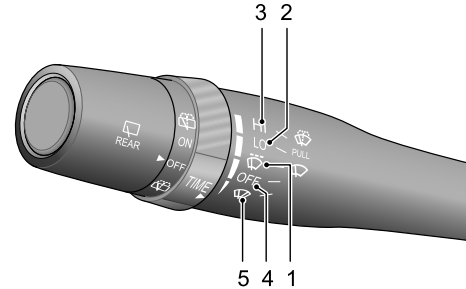

Place the stalk switch to the position required.

Position 1 – : Intermittent wiping. For a vehicle equipped with an automatic wipers, its rain sensor will detect the rainfall on the windshield and automatically adjust the wiping frequency of windshield wipers.

Note: *Ensure the rain sensor is free of dust, dirt and ice.*

Position 2 –LO: Low-speed wiping.

Position 3 –HI: High-speed wiping.

Position 4 –OFF: Turn off wipers.

Position 5 – : Single wiping.

Before You Drive

Intermittent wiping/interval adjustable

! If worn wiper blades cannot clear rain from the front windshield, the forward visibility will be lowered, which may lead to an accident. Be sure to replace worn wiper blades in time.

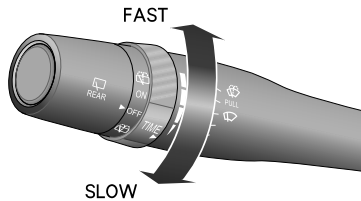

For vehicles not equipped with a rain sensor, when the stalk switch is placed in  (Intermittent) position, rotate the switch to change the wiping interval.

For vehicles equipped with a rain sensor, when the stalk switch is placed in  (Intermittent) position, rotate the switch to change the wiper sensitivity, and adjust the wiping speed of the front wipers.

Caution

In cold or hot days, in order to prevent damaging wipers, please clear barriers from the windshield (such as snow) if wiper blades are frozen or adhere to the windshield. Do not operate wipers when leaving the windshield dry. Otherwise the windshield may be damaged, wiper blades may be worn prematurely, and the driver's vision may be affected.

Washer

Pull the stalk switch towards the steering wheel, and the washer will start operating immediately. After a transient interval, wipers and washer will operate in linkage. The washer will be turned off after the stalk switch is released.

Note: After the stalk switch is released, wipers will continue conducting wiping operations for 3 times.

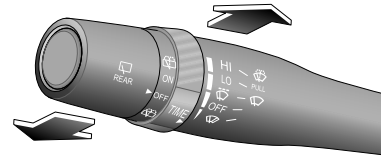

Before You Drive

Rear window wipers and washers

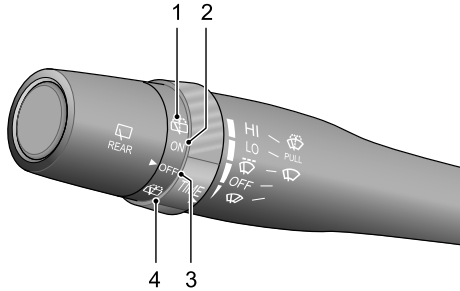

Rotate the stalk switch to the desired position.

Position 1, 4 – : washers spraying water and wipers running.

Position 2 –ON: normal wiper running.

Position 3 –OFF: wiper off.

Instrument cluster selection and cruise switch

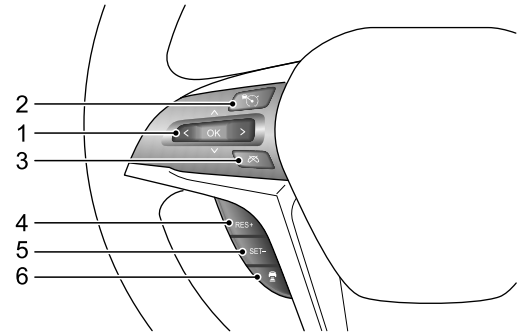

1



Position 1 –  : instrument cluster selection button. Press up, down, left and right to enter the instrument cluster for page up, down, left and right, and press the OK button to confirm the selection.

Before You Drive

Constant speed cruise control system

Position 2 – : Cruise on/off switch. Press this button to turn on/off the cruise control system. The "Constant Speed Cruise Indicator Lamp" on the instrument cluster will illuminate or go out.

Position 3 – : Cruise cancel switch. Press this button to cancel the cruise function without clearing the set speed in the memory.

Position 4 – RES+: Cruise recovery/acceleration switch. To store the set speed, press this button to recover this speed. Press this button again to accelerate (1km/h per time).

Position 5 – SET-: Cruise setting/deceleration switch. Press this button to set the speed. Then the cruise function will be enabled and the "Constant Speed Cruise Indicator Lamp" on the instrument cluster will turn green from white. If the cruise function is enabled at this time, press this button to lower the cruise speed (1km/h per time).

Note: Please refer to "Constant Speed Cruise Control System" in the Starting and Driving section for more description about cruise function.

Adaptive Cruise Control (ACC)

Position 2 – : adaptive cruise master switch, press it to turn the system on or off.

When the ACC is On:

Position 3 – : it is the adaptive cruise exit switch, press it to disable the adaptive cruise control, but do not clear the set cruise speed.

Position 4 – RES+: increase the stored speed or re-activate the adaptive cruise control and resume the stored speed.

Position 5 – SET-: decrease the stored speed or activate the adaptive cruise control and store the current speed.

Position 6 – : vehicle-to-vehicle distance setting, adjust the vehicle-to-vehicle distance of the adaptive cruise control, the vehicle-to-vehicle distance will be cycled among level 1 - 3 by each press.

Note: Please refer to "Driver Assistant System" in the Starting and Driving section for more description about cruise function.

Before You Drive



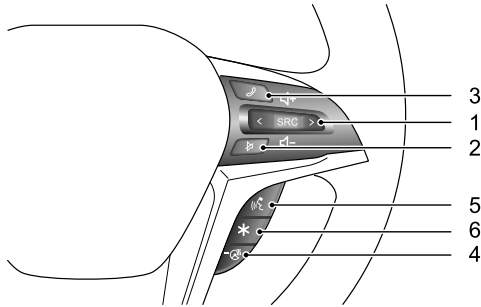

Voice control, Bluetooth phone, steering wheel heating and customized switch

Type I

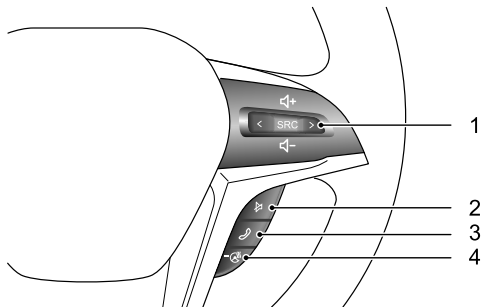



Type II





Position 1 –  : audio source switch. Press SRC to switch between the radio and MP3 playback interfaces, press up to increase the volume, press down to decrease the volume; short press , switch to previous band/MP3 track, long press , fast rewind; short press , switch to next band/MP3 track, long press , fast forward.

Position 2 –  : Mute switch.

Position 3 –  : Bluetooth phone switch. When Bluetooth is connected, this button is the Bluetooth phone answering switch. In the general calling state: In case of an incoming call, short press this button to answer; long press this button to hang up; during a call, short press this button to hang up. In the call waiting state: Short press this button to hung up the call waiting; long press this button to answer the call waiting.

Position 4 –  : steering wheel heating switch. Press this button to activate the steering wheel heating function, and its indicator illuminates. Press it again to disable the steering wheel heating function.

Position 5 –  : Voice dialogue system switch. Press this button to enable voice recognition function; press this button to disable voice recognition function.

Position 6 –  : Custom setting switch. Press this button to conduct custom setting.

Before You Drive

Steering Wheel Adjustment

! Do not adjust the steering wheel position during driving. This is extremely dangerous.

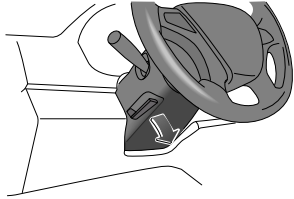

Adjust the steering wheel position to adapt to your driving posture through the following steps:

- 1 Fully release the steering wheel adjusting handle on the steering column downwards;
- 2 Grasp the steering wheel firmly with both hands, and move the steering wheel upwards or downwards, backwards or forwards to adjust it to a proper position;

Note: If it is still difficult to move the steering wheel to a proper position, place the ignition switch in ON position to unlock the steering wheel, and turn the steering wheel to the straight forward position.

- 3 Select a proper driving position, and pull the steering wheel adjusting handle fully up to lock the steering wheel into its new position.

Horn

Regardless of the ignition switch position, the horn can work once you press the button.

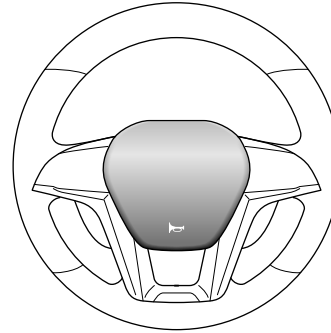

Heating, Ventilation and Air Conditioning

The air conditioning system can cool down the air and remove the moisture and the dust (e.g., pollen) in the air.

The heating system utilizes the heat generated by the engine, so it can heat the air in the vehicle sufficiently only when the engine gets to the normal operating temperature. If equipped with PTC air-conditioning auxiliary heating system, the heating effect of air-conditioning can be improved.

The ventilation system ensures the interior ventilation when driving.

The front and rear A/C air volume selection buttons control the air volume.

HVAC is used to control the cooling, heating and ventilation of the air inside the vehicle. Fresh air is drawn into the vehicle through the air intake grille under the windshield, and flowing through the air conditioning filter. Always keep the air intake grille clean, free of obstructions such as leaves, snow or ice.

Front vents

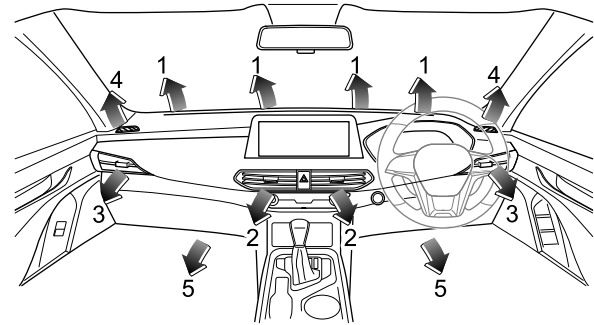

- 1 Windshield vent
- 2 Central vent
- 3 Side vent
- 4 Front window vent
- 5 Front feet vent

Before You Drive

Central vent

Move the lever (1) in the center of the grille up and down, right and left to change the direction of the air distribution.

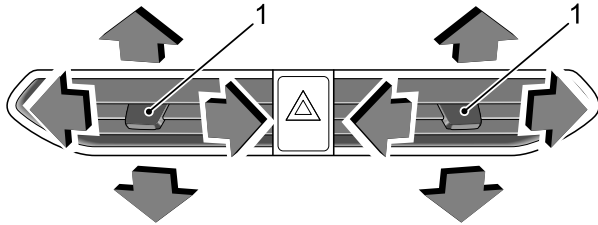

Side vent

Move the lever in the center of the grille up and down, right and left to change the direction of the air distribution.

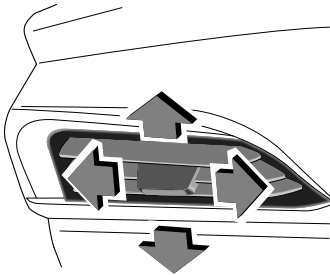

Rear vent

Turn the grille or move the lever (1) in the center of the grille to change the direction of air distribution. There are 4 ceiling vents, 2 on each side.

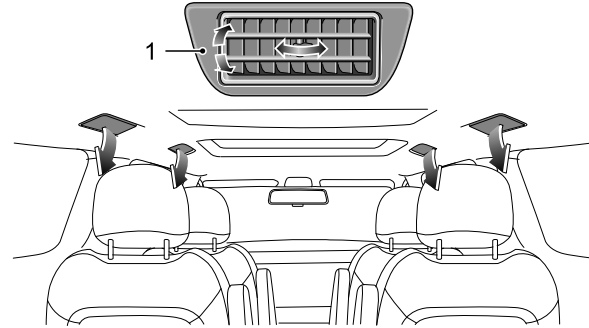

Automatic A/C front control panel

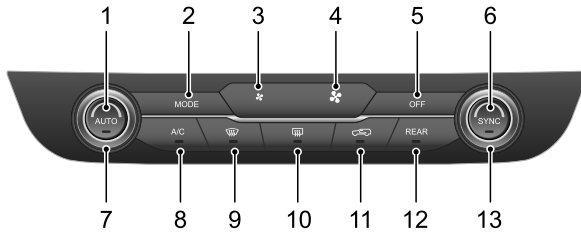

- 1 AUTO button
- 2 MODE button
- 3 Front A/C air volume - selection button
- 4 Front A/C air volume + selection button
- 5 OFF button
- 6 SYNC button
- 7 Left temperature selection knob
- 8 A/C button
- 9 Front defrost button
- 10 Rear defrost button
- 11 Internal/external circulation button
- 12 Rear A/C control button
- 13 Right temperature selection button

AUTO button

This is the automatic air conditioning control mode button.

Press the AUTO button to enter the full AUTO state, each control will enter the automatic working state, the AUTO indicator illuminates, in the full AUTO state, press the AUTO button again to disable it.

In the AUTO state, operate the MODE, air volume, A/C buttons, the panel will exit the full AUTO state, the AUTO indicator goes out, and the relevant functions enter the manual control state, while other functions that are not operated remain in auto control.

In the AUTO state, operate the temperature control knob, the panel still remains in the full AUTO state, and the AUTO indicator stays on.

In the AUTO state, operate the internal/external circulation button, the relevant functions enter in the manual control state, the AUTO indicator stays on, while other functions that are not operated remain in auto control.

In the AUTO state, operate the front defrost button, the A/C enters the front defrost state, and the AUTO indicator goes out.

MODE button

Adjust the air distribution mode.

If MODE button is pressed in the ON state, A/C will switch to the Distribution to Face, Distribution to Face and Feet, Distribution to Feet, Distribution to Feet and Defrost mode in turn, and the

Before You Drive

infotainment display will display the information about the related air distribution mode.

The operation of MODE is invalid in the OFF state, the mode will recover the non-defrosting mode memorized before powered off.

MODE button can be operated to switch the modes in AUTO state, while the mode control will change to the manual control from AUTO control, the AUTO indicator goes off and other features maintain in AUTO state.

Front A/C air volume selection button

There are 2 front A/C air volume selection buttons: the air volume + button and air volume - button. there are totally 8 air volume levels, the air volume indication is displayed on the entertainment system large-screen display.

The air volume of A/C increases by one level once the air volume + button is pressed; the air volume decreases by one level once the air volume - button is pressed.

When the air volume + button is pressed more than 1 seconds, the volume increases to the top level slowly; When the air volume - button is pressed more than 1 seconds, the volume reduces to the minimum level slowly.

If the air volume + or - button is pressed in OFF state, the system starts, the volume level indicator shows the level before power off directly, the air volume slowly increases to this level from level one and other function maintains the non-defrosting state last activated before powered off.

OFF button

When the panel is in the working state, press the OFF button, the A/C panel enters the off state, the A/C output is closed, the air volume is 0, the mode motor, heating and cooling motor, and internal and external circulation motor stop after running to the target position

In the off state, it can be turned on by operating the AUTO mode button, the front defrost button, the A/C button and the air volume adjusting button.

If the engine stalls, the A/C control panel will memorize the power state before stalling, when the vehicle is powered on again, this panel will go back to the non-defrosting mode last activated before stalling.

In the off state, the internal/external circulation indicator lamp, the rear defrost indicator lamp on the panel indicate their current state, and other indicator lamps go out.

SYNC button

The SYNC button is the button to switch the synchronization and asynchronization of front A/C left and right dual zones.

The indicator lamp On indicates the single zone mode, while the indicator lamp Off indicates the dual zone mode.

When the SYNC indicator lamp is on, the user may operate the temperature setting knob at driver side to adjust the temperature at the front passenger side, so that the set temperature at driver side and front passenger side changes synchronously.

When the SYNC indicator lamp is off, the user may adjust the set temperature at driver side or front passenger side without affecting each other.

Temperature Selection Knob

Adjust the A/C set temperatures at driver side or front passenger side.

The temperature selection knob can be rotated and adjusted within 360°, if it is rotated counterclockwise, the set temperature is reduced; if it is rotated clockwise, the set temperature is rising. The set temperature range is LO, 18°C - 32°C, HI, the temperature increment is 1°C if it is rotated one grade, and this set temperature will be displayed on the infotainment display. LO indicates MAX cooling, HI indicates MAX heating.

The first power-on temperature (factory configuration) is the middle level, and the corresponding LCD display is 25°C.

The temperature value will be memorized at the time of shutdown.

A/C Button

Switch on and off the compressor.

If A/C button is pressed regardless of Power OFF or ON, the corresponding indicator comes on and the infotainment display shows the A/C startup information, and the compressor is activated (vehicle is started); if the A/C button is pressed a second time, the A/C button indicator goes off and the compressor is turned off.

A/C is controlled automatically in AUTO mode, and it changes to the manual control from AUTO control by operating the A/C button, then AUTO indicator goes off, other features maintain in AUTO mode.

Front Defrost Button

Adjust the air distribution mode to Front Defrost.

If the Front Defrost button is pressed in OFF or ON state, the corresponding indicator comes on and MAX defrost is shown on the infotainment display. The volume level increases to the 6th level slowly with the automatic system control, the external circulating air enters into the vehicle, AC is turned on and the blower air distribution mode is the maximum defrost. However, the internal/external circulation mode, the air volume and A/C are adjustable.

In Front Defrost state, if the Front Defrost button or MODE button is pressed a second time, the front defrost function is turned off, the front defrost indicator goes off and the system returns to the previous state before the front defrost. If the previous state is OFF, it will return to the non-defrosting state before powered off.

Rear Defrost Button

Switch on the rear defrost state. Rear defrost can be activated only when the ignition switch is turned to On position. The operation of the Rear Defrost button will not change another air conditioning states regardless of power on or off, meanwhile the corresponding indicator and the rear defrost information on

Before You Drive

the infotainment display vary according to the rear defrost state (vehicle is started).

For vehicles equipped with the heated exterior rearview mirror, press the Rear Defrost Button to activate the heated exterior rearview mirror, to help clear the fog or frost on the surface of rearview mirror.

Note: The rear defrost will stop after operating for 15 minutes, and its indicator goes off.

Internal/External Circulation Button

Switch between the internal and external circulation with the button, when the internal circulation indicator lamp illuminates, it indicates that it is in internal circulation, when the indicator lamp goes out, it indicates that it is in external circulation.

when it is in the defrost mode, switch to external circulation forcibly, then you can switch back to internal circulation manually.

Rear A/C control button

When the ignition switch is in ON position, the REAR button can make adjustments. Press the button, the indicator lamp illuminates, which indicates that the front A/C panel can control the rear A/C, at this time, the adjustments made with the mode, air volume, temperature (left or right), AUTO, OFF buttons on the front A/C panel are to adjust the relevant information of rear A/C, if a rear occupant operates the rear A/C control panel at the time, the signal firstly received in 100ms will be executed; press the REAR button again, the indicator lamp goes out, which indicates

that the front A/C control panel resumes its control on the front A/C, and the rear A/C can only be adjusted with the rear A/C control panel.

If the REAR indicator is On, after the passenger stops regulating the front A/C panel for 8 seconds, the indicator automatically goes out, and the front A/C panel will resume its control on the front A/C.

Electronic A/C front control panel

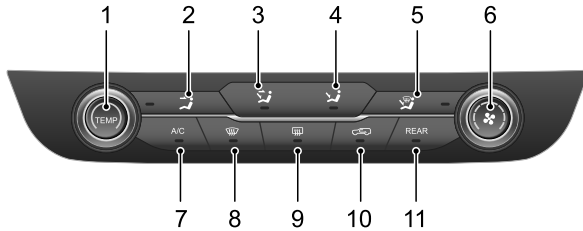

- 1 Temperature selection knob
- 2 Distribution to Face mode button
- 3 Distribution to Face and Feet mode button
- 4 Distribution to Feet mode button
- 5 Distribution to Feet and Defrost button
- 6 Air volume adjusting knob
- 7 A/C button
- 8 Front defrost button
- 9 Rear defrost button
- 10 Internal/external circulation button
- 11 Rear A/C control button

Temperature selection knob

Adjust the A/C set temperature.

The temperature selection knob can be rotated and adjusted in 15 levels, if it is rotated counterclockwise, the set temperature is gradually reduced; if it is rotated clockwise, the set temperature is gradually rising.

Distribution to Face mode button

Adjust the air distribution mode to Distribution to Face.

In the ON state, if the Distribution to Face mode button is pressed, the corresponding indicator comes on and it becomes the Distribution to Face mode, the operation of the Distribution to Face mode button is invalid at this time, and it will change to other modes if another mode button is pressed.

Distribution to Face and Feet Mode Button

Adjust the air distribution mode to Distribution to Face and Feet.

In the ON state, if the Distribution to Face and Feet Mode button is pressed, the corresponding indicator comes on and it becomes the Distribution to Face and Feet Mode, the operation of the Distribution to Face and Feet Mode button is invalid at this time, and it will change to other modes if another mode button is pressed.

Distribution to Feet Mode Button

Adjust the air distribution mode to Distribution to Feet.

Before You Drive

In the ON state, if the Distribution to Feet Mode button is pressed, the corresponding indicator comes on and it becomes the Distribution to Feet Mode, the operation of the Distribution to Feet Mode button is invalid at this time, and it will change to other modes if another mode button is pressed.

Distribution to Feet and Defrost Mode button

Adjust the air distribution mode to Distribution to Feet and Defrost.

In the ON state, if the Distribution to Feet and Defrost Mode button is pressed, the corresponding indicator comes on and it becomes the Distribution to Feet and Defrost Mode, the operation of the Distribution to Feet and Defrost Mode button is invalid at this time, and it will change to other modes if another mode button is pressed.

Air volume adjusting knob

Adjust the blower air volume.

The air volume is divided into 8 levels. Rotate a grid to the right, the A/C air volume will increase by one level; rotate a grid to the left, the air volume will decrease by one level. When the air volume is adjusted to the 8th level, the knob reaches the far right and can no longer be rotated to the right; when the air volume is adjusted to the 0 level, the knob reaches the far left and can no longer be rotated to the left.

A/C button

Switch on and off the compressor.

With the blower in ON state, press the A/C button, the corresponding indicator lamp illuminates and the compressor is turned on (engine is started); press the A/C button again, the A/C indicator lamp goes out and the compressor is turned off.

Front Defrost Button

Adjust the air distribution mode to Front Defrost.

With the blower in the on state, press the front defrost button, the corresponding indicator lamp illuminates, the air volume remains in the current level, air flows into the vehicle through the external circulation, AC is turned on and the air distribution mode is defrost. At this time, the internal/external circulation mode, air volume and A/C are adjustable.

In the Front Defrost state, if the Front Defrost button or other mode buttons are pressed a second time, the front defrost function is off, the front defrost indicator goes off and the system returns to the previous state before the Front Defrost.

Rear Defrost Button

Switch on the rear defrost state. Rear defrost can be activated only when the ignition switch is turned to On position. The operation of the Rear Defrost button will not change other air conditioning states regardless of power on or off, meanwhile the corresponding indicator varies according to the rear defrost state (vehicle is started).

Before You Drive

For vehicles equipped with the heated exterior rearview mirror, press the Rear Defrost Button to activate the heated exterior rearview mirror, to help clear the fog or frost on the surface of rearview mirror.

Note: *The rear defrost will stop after operating for 15 minutes, and its indicator goes off.*

Internal/External Circulation Button

Switch between the internal and external circulation with the button, when the internal circulation indicator lamp illuminates, it indicates that it is in internal circulation, when the indicator lamp goes out, it indicates that it is in external circulation.

when it is in the defrost mode, switch to external circulation forcibly, then you can switch back to internal circulation manually.

It is defaulted to memorize the state before the shutdown at the power-on.

Rear A/C control button

When the ignition switch is in ON position, the REAR button can make adjustments. The REAR button indicator lamp illuminates, which indicates that the rear A/C is in the operating state, press the REAR button at this time, the indicator lamp goes out, and the rear A/C is turned off; the REAR button indicator lamp off indicates that the rear A/C is in off state, press the REAR button at this time, the indicator lamp illuminates, and the rear A/C is turned on.

Automatic A/C rear control panel

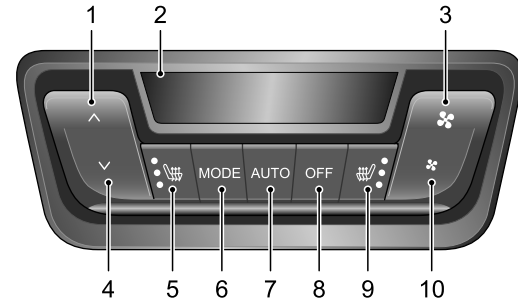

- 1 Rear A/C temperature + selection button
- 2 Rear A/C display
- 3 Rear A/C air volume + adjusting button
- 4 Rear A/C temperature - selection button
- 5 2nd row left seat heating button
- 6 Rear A/C mode button
- 7 Rear A/C AUTO button
- 8 Rear A/C panel OFF button
- 9 2nd row right seat heating button
- 10 Rear A/C air volume - adjusting button

Before You Drive

Rear A/C temperature selection button

There are 2 rear A/C temperature selection button, namely, temperature + button and temperature - button, there are totally 8 temperature levels.

In the OFF state, the temperature + and - buttons are invalid, in other states, the temperature + and - buttons can adjust the temperature, but do not change other states of the controller.

Press the temperature + button once, the set temperature will increase by 1 level, and it will change continuously after long pressing the button for 1 seconds.

Press the temperature - button once, the set temperature will decrease by 1 level, and it will change continuously after long pressing the button for 1 seconds.

Rear A/C air volume adjusting buttons

Adjust the air volume, there are 6 levels for each button.

The air volume of A/C increases by one level once the air volume + button is pressed; the air volume decreases by one level once the air volume - button is pressed.

When long pressing the air volume + button for more than 1 second, the air volume will continuously increase to the 6th level by changing 1 level every 0.5 second.

When long pressing the air volume - button for more than 1 second, the air volume will continuously decrease to the 1st level by changing 1 level every 0.5 second.

Press the air volume button into the OFF state, the controller will exit the OFF state and return to the state before OFF, and the air volume level before OFF in memory will be recalled.

In the OFF state, by pressing the air volume + or - button, the controller will enter the ON state, and the air volume output will gradually increase from the 1st level to the one before OFF in memory, and other functions maintain the state before OFF.

2nd row seat heating buttons

The 2nd row left seat heating button and 2nd row right seat heating button will conduct auxiliary heating to the seats at both sides respectively.

After the 2nd row left seat or right seat heating button is pressed, the corresponding seat heating function is activated (vehicle started), meanwhile the corresponding indicator lamp illuminates, press the button once to decrease by 1 level, and the level is indicated by the indicator lamp in the button.

Pressing the OFF button does not affect the operating state of seat heating.

The 2nd row seat heating is operative only when the engine is started, each time you re-ignite after the shutdown, the seat heating is in the OFF state by default.

Rear A/C mode button

Change the air distribution state of the damper, press the mode button to switch to the following air distribution state of the

Before You Drive

damper in sequence: Distribution to Face mode, Distribution to Face and Feet mode, Distribution to Feet mode.

Rear A/C AUTO button

After pressing the AUTO button, the A/C enters the AUTO control mode, the AUTO icon is displayed on the LCD.

In the AUTO state, press either of the mode, air volume button, the corresponding function will exit the AUTO mode, and other functions remains unchanged, the AUTO icon on the LCD will go out.

Rear A/C panel OFF button

Used for power on/off, in the OFF state, press the mode button again, and the heating and cooling buttons will not respond.

Press the OFF button to switch to the OFF state, the LCD output is closed, the air volume is in 0 level, and the mode motor, the heating and cooling motor stops after running to the position set before OFF.

In the OFF state, operate the air volume button or AUTO button to enter the On state, the air volume, mode, AUTO, set temperature will resume to the state before OFF.

Electronic A/C rear control panel

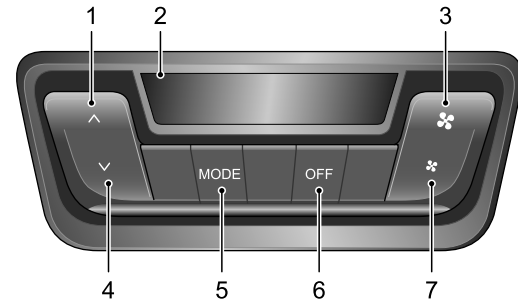

- 1 Rear A/C temperature + selection button
- 2 Rear A/C display
- 3 Rear A/C air volume + adjusting button
- 4 Rear A/C temperature - selection button
- 5 Rear A/C mode button
- 6 Rear A/C panel OFF button
- 7 Rear A/C air volume - adjusting button

Note: Please refer to "Automatic A/C Rear Control Panel" in this section for the operating and control logic of the functions contained in this control panel.

Before You Drive

Recommendation for A/C operation

- If the vehicle is parked in a place that is exposed to the direct sunlight, open the windows before operation.
- If the fogged windows need to be cleaned in a rain day, reduce the moisture in the vehicle by operating the air conditioning. This is very effective in rainy season and a season with heavy moisture.
- If the vehicle is driving in the city, the stop-and-go may cause the insufficient cooling.

Note: *If the air conditioning will not be in use for more than one month, run the engine at idle speed and turn on the system for more than 10 minutes (once every month, including in winter). This aims to maintain the proper lubrication of the compressor and the seals, so as to extend the service life of the system.*

Note: *Condensation may be formed on the evaporator when the A/C is operating. So you may find a small pool of water under the vehicle after the vehicle is stopped.*

Rearview Mirrors

In order to extend the view range, exterior rearview mirrors are convex-shape, which makes objects look smaller and farther than the actual.

Caution

Be sure to check and ensure that all rearview mirrors are clean and bright, and adjusted well before driving; clean and adjust them if necessary.

Exterior Rearview Mirrors

Power rearview mirrors

Press the switchL(left) orR(right) to select the rearview mirror to be adjusted. Move the rearview mirror switch towards front/rear/left/right to adjust the rearview mirror lens to tilt towards up/down/left/right to the position required. Move the switch to the middle position.

Switches not equipped with power folding function

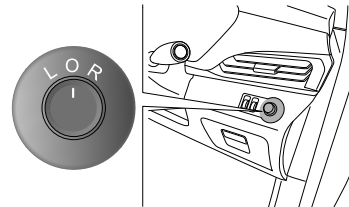

Switches equipped with power folding function

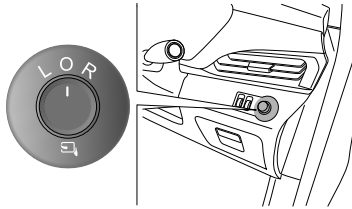

Folding rearview mirrors

Manual folding of rearview mirrors

In order to ensure the safety of pedestrians, exterior mirrors will rotate from their normal mounting positions towards both sides if impacted with a strong force. Reset the rearview mirrors by applying little pressure onto the mirror frames.

Power folding of rearview mirrors

For vehicles equipped with power folding rearview mirrors, it is allowed to fold/unfold exterior mirrors manually/automatically.

- Manual power folding/unfolding of rearview mirrors

When rearview mirrors are folded, turn the ignition switch to "ACC"/"ON" position and move the switch to any of L/O/R position, the rearview mirrors will be unfolded.

When rearview mirrors are unfolded, turn the ignition switch to ACC/ON position and move the switch to  position, the rearview mirrors will be folded.

- Automatic power folding/unfolding of rearview mirrors

When rearview mirrors are folded and the ignition switch is placed in OFF position, the key to unlock, then rearview mirrors will be unfolded automatically. Or, rearview mirrors will be automatically unfolded as long as there is a legitimate remote key with PEPS existing within the range of 1 meter around the vehicle, press the micro switch on the driver door handle.

When rearview mirrors are unfolded and the ignition switch is placed in OFF position, the key to lock, then rearview mirrors will be folded automatically. Besides, when doors are unlocked but not opened, after 30s, doors will be automatically locked again and rearview mirrors will resume to folding state.

Memory position function of front power driver seat

The position of rearview mirrors can be stored in the memory position function of the power driver seat. Please refer to "Seats" in this Section for details.

Heated rearview mirrors

For vehicles equipped with the heated exterior rearview mirror, press the Rear Defrost Button  on the A/C control panel to heat the exterior rearview mirror.

Before You Drive

Exterior rearview mirrors automatically tilt during reversing

When the driver shifts the lever to the R gear position, the exterior rearview mirrors on both sides will tilt automatically, letting the driver see the curbs or rear wheels and facilitating the reverse operation. When the driver moves the shift lever out of the R gear position to finish the reversing, the exterior rearview mirrors will return to their original positions automatically.

The touch buttons on the large-size screen of entertainment system control the enabling and disabling of the automatic tilt function of exterior rearview mirrors during reversing. Please refer to the operating instructions accompanied with the entertainment system head unit for details.

Exterior rearview mirrors automatically tilt during reversing function setting

Place the ignition switch in “ON” position, apply the brake pedal to stop the vehicle. Shift the lever to R gear position, adjust to tilt the left and right rearview mirrors respectively to the desired position. Move the shift lever out of the R gear position and the rearview mirrors will return to their original positions automatically.

Interior rearview mirror

Adjust the rearview mirror to obtain the required rear view.

Manual adjustment of interior rearview mirror

Operate the adjusting lever on the bottom of rearview mirror to reduce reflected glare during night driving.

Power adjustment of interior rearview mirror

For vehicles equipped with power adjusting interior rearview mirror, press the AUTO button (2) on the rearview mirror bottom. Then the green LED lamp (1) will illuminate and rear light sensor will start operating to reduce reflected glare during night driving. Press the button (2) again. Then the green LED lamp will go off and rear light sensor will stop operating.

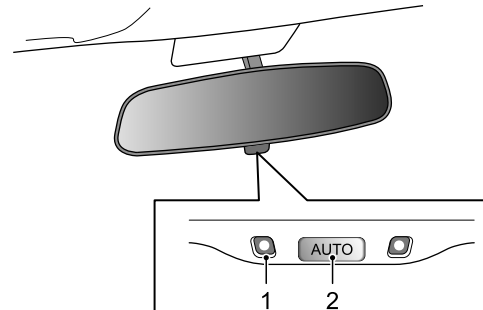

Interior Devices

Ceiling reading lamps

Front ceiling reading lamp



Turn on the reading lamp

Press , to turn on the internal reading lamp.

Turn on door control mode

Press , the internal reading lamps will automatically illuminate after any one door is opened, and go out approximately 30 seconds after the door is closed.

With the doors closed, place the switch in  position, press the black cover, and turn on the internal reading lamp.

Turn off the reading lamp



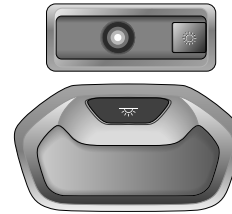

Press , to turn off the internal reading lamp.

With the doors closed, place the switch in  position, press the black cover, and turn on the internal reading lamp.

Rear ceiling reading lamp



On/off switch

When the front ceiling reading lamp is in the door control mode, and all doors are closed, press the  , turn on the rear ceiling reading lamp, and press the   again, turn off the rear ceiling reading lamp. When any door is opened, rear ceiling reading lamps will go on. About 30s after the door is closed, rear ceiling reading lamps will go off automatically. When any door is opened, rear ceiling reading lamps will go on. About 30s after the door is closed, rear ceiling reading lamps will go off automatically.

Note: 15min after any door is opened, rear ceiling reading lamps will go off automatically to prevent battery drain.

Before You Drive

On-board inverter



Please pay attention to electric safety during usage. Prevent children from contacting this outlet. Danger! High voltage!

Do not insert finger or a conductive object into this outlet. Please keep liquid objects away from this outlet.

The maximum rated power of inverter is 150W. Do not use any electric appliance with a power more than 150W.

On-board inverter is located behind the bottom of central armrest between the driver and front passenger seats. Open the panel, and you will see the 220V AC power outlet, which can provide an output power of 150W. When the ignition switch is placed in "ACC" position, the on-board inverter will start operating. Please pay attention to the indicator lamp showing the power supply operating state near the outlet during usage, and operate according to the prompts provided by the indicator lamp:

- 1 Green lamp on: Normal operation.
- 2 Indicator lamp off: low battery voltage. Please remove the electrical appliance, and wait for the battery voltage to return to normal.
- 3 Red lamp flashes:

- High battery voltage. Please wait for the battery voltage to return to normal.
- 220V power supply temperature is excessively high. Please remove the electric appliance and wait for the green lamp to go on.
- 220V power supply output overload. Please remove the electric appliance and restart the engine to recover normal operation.
- External short circuit. Please remove the electric appliance and restart the engine to recover normal operation.

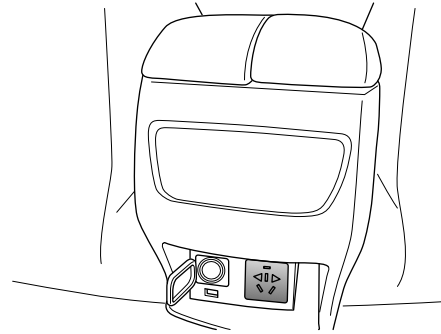

Caution

Please avoid using the on-board inverter for a long time when the ignition switch is placed in ACC position, which will lead to battery drain.

Before You Drive

USB port

The USB ports are located in the storage box of floor console, at the rear bottom side of central armrest, and on the left rear side armrest.

Caution

Please do not use the USB port for a long time when the ignition switch is placed in ACC position, which may lead to battery drain.

The USB port in the storage box of floor console

The USB port in the storage box of floor console can be used for charging and multimedia files playback, please refer to "MP3+Radio" and "MP5+Radio" in this section for the method of multimedia file playback via USB and the file requirements.

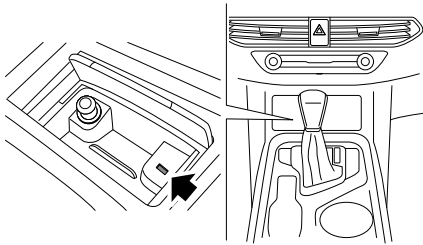

The USB port at the rear bottom side of central armrest

The USB port at the rear bottom side of central armrest can be used for charging or multimedia file playback, (this function depends on the actual configuration of your vehicle), please refer to "MP5+Radio" in this section for the method of multimedia file playback via USB and the file requirements.

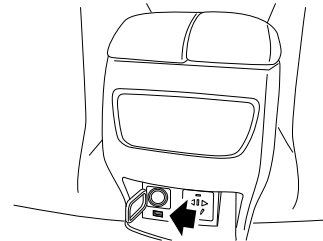

The USB port on the left rear side armrest

The USB port on the left rear side armrest can be used for charging.

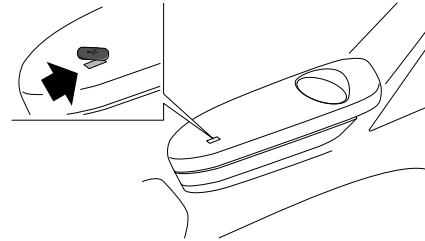

Before You Drive

12V power outlet

The power outlets are located at the rear bottom side of central armrest between the driver and front passenger, on the right rear side armrest, at the left side of luggage compartment, they are mainly used for providing power supply connection for external electric devices.

Caution

Please avoid using the power outlet for a long time when the ignition switch is placed in ACC position, which will lead to battery drain.

Note: *The power outlet can provide power supply for electric devices of which power is no more than 120W.*

Rear bottom side of central armrest

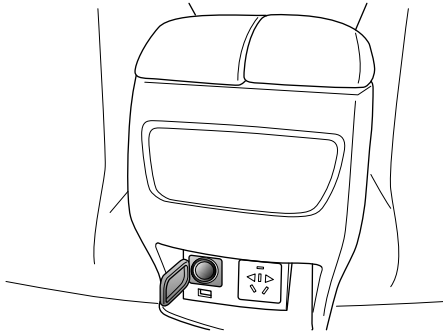

Right rear side armrest

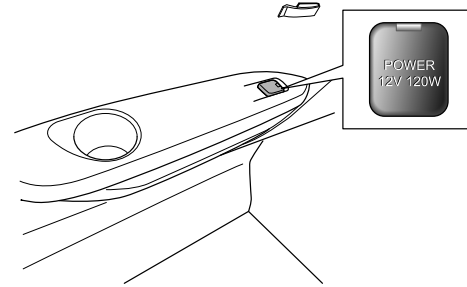

Left side of luggage compartment

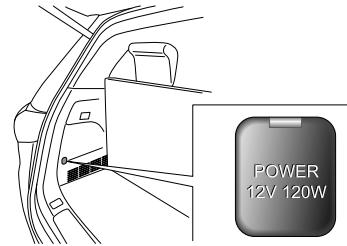

Before You Drive

Cigar lighter

! Release the cigar lighter in time after pressing it, otherwise it may be damaged.

Do not plug any accessory on the cigar lighter outlet.

If leaving a child alone in the vehicle, be sure to remove the cigar lighter just in case.

The cigar lighter is scalding and may cause burn. Therefore, hold the cigar lighter steadily through the knob during usage.

During operation, press down the cigar knob completely and release it. After heating, the knob will pop up partially and can be taken out for usage.

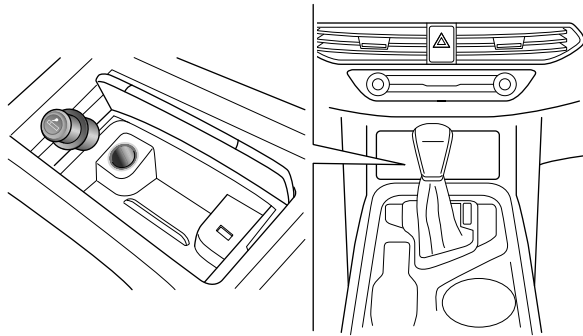

Ashtray

! There is a fire risk in the ashtray. A fire may be caused if you place a lighted cigar and combustible matter together. Do not use the ashtray as a dustbin.

The ashtray of the vehicle is located in the floor console, open the ashtray by opening the ashtray cover.

To empty the ashtray, hold one side of ashtray to remove it.

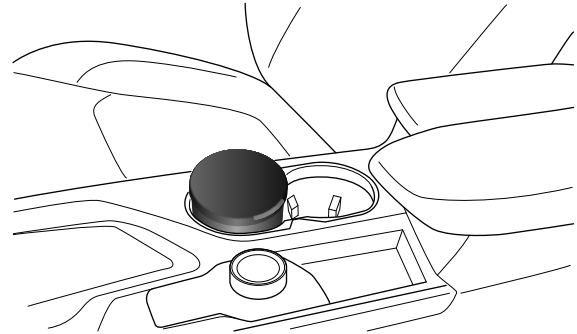

1

Before You Drive

Cup holder

Cup holder on the floor console

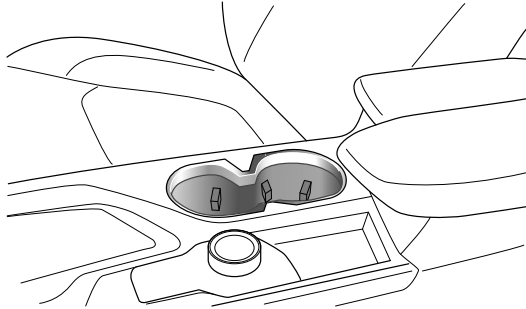

Cup holder on the armrest of second row seats

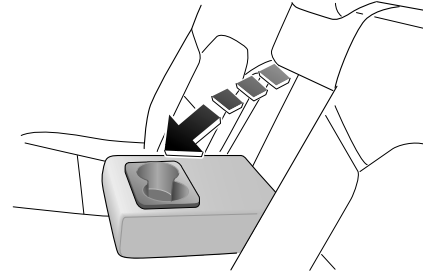

Cup holder at both sides of third row seats

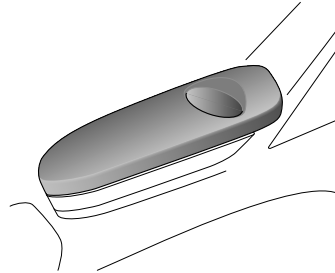

Before You Drive

Storage box

Storage box at driver side

The storage box at driver side is located below the front of the floor console at driver side. It can be opened by releasing the storage box upper buckle.

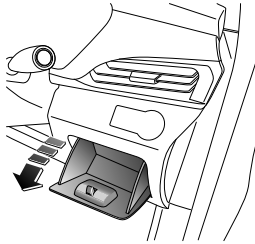

Storage box of floor console

It is located in the front of the floor console, press the storage box to open, and press it again to close.

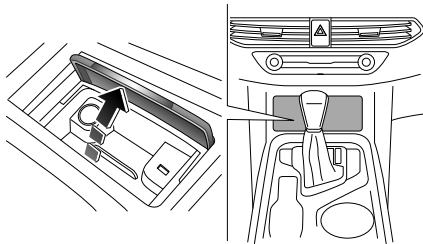

Storage box under the front armrest

Type I

Lift the armrest to open the storage box.

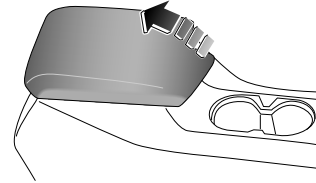

Type II

When the unlock button is pressed, the cover will pop up and open automatically.

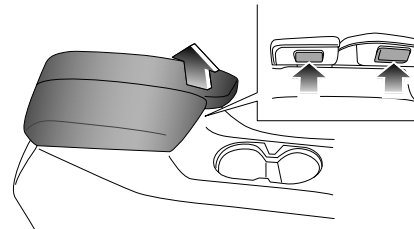

1

Before You Drive

Glove box

! Do not place a sharp, heavy or hazardous object in the glove box at front passenger side.

In case of an accident or sudden braking, the glove box may cause personal injury if not closed. Therefore, please close the glove box during driving.

Press the button on the upper side of glove box to open the glove box (if your vehicle is equipped with a glove box lock, you need to insert the key and turn it counterclockwise to unlock). Push it hard to close it.

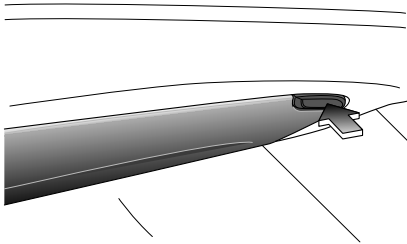

Sun visor and vanity mirror

Pull both sun visors upwards or downwards to block the sunshine through windshield. Besides, sun visors can be rotated towards side windows.

Turn a sun visor downwards and open the vanity mirror cover. Then you can use the vanity mirror.

Driver's vanity mirror shall be used only when the vehicle stops.

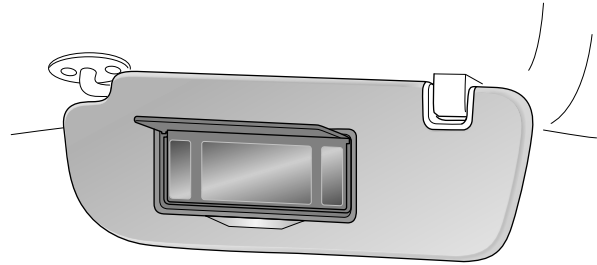

Before You Drive

Glasses box

Flip the glasses box in the direction of the arrow to open it.

Note: *The glasses box should be used when the vehicle is stopped. The glasses box can only be used for glasses with standard frame. Some large Sunglasses may not fit into the case.*

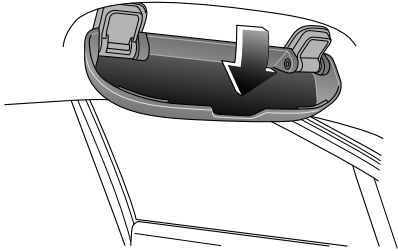

Fire extinguisher

Note: *It is subject to the actual configuration of the vehicle you purchased.*

! Once activated, the fire extinguisher should be replaced even if there are not many jets.

The dry powder fire extinguisher is placed in the storage box of luggage compartment.

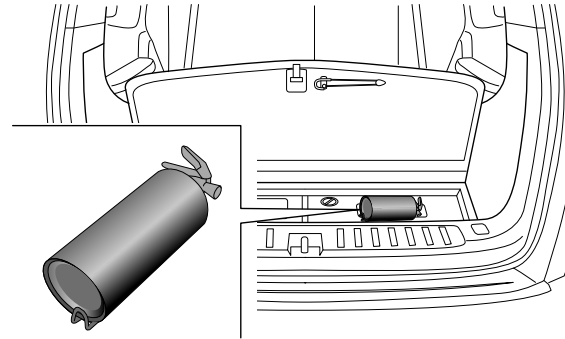

1

Before You Drive

The use of the portable fire extinguisher

- 1 Pull out the safety pin;

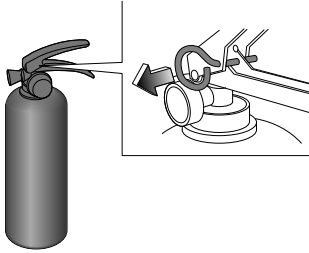

- 2 Aim at the root of the fire source, and push the handle simultaneously to extinguish the fire.

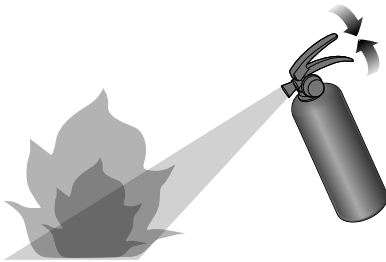

In outdoor use, select to spray at the upwind direction. Intermittent spray may be adopted in its use. When extinguishing the fire of flammable liquid, do not spray by aiming

at the liquid surface directly, so as to prevent the flammable liquid from splashing due to the impact force and expanding the fire, resulting in fire fighting difficulties. When fighting the ordinary fire of solid materials, spray by aiming at the most violent combustion area, and spray in the up and down, left and right direction; when the conditions permit, you may walk and spray around the combustion material, so that the dry powder fire extinguishing agent can be evenly sprayed on the surface of the combustion material, until the flame is fully extinguished. When fighting the fire of energized equipment (not suitable for fighting the fire of equipment with high voltage), cut off the power first. The user of fire extinguisher shall pay attention not to touch the energized equipment, to avoid the occurrence of an electric shock which endangers the personal safety. The fire shall be extinguished completely to prevent the re-ignition of flame.

Fire extinguisher inspection and maintenance

The user shall make the inspection immediately after taking the vehicle, and then make it at the interval of 1 quarter, in the severe environment, the fire extinguisher shall be inspected more frequently, and the contents of the inspection are as follows:

- 1 The pointer of the fire extinguisher pressure indicator shall be in the green zone;
- 2 The safety pin and sealing label shall be intact;

Before You Drive

- 3 The cylinder body is free of rust, deformation, and all components have no deformation and damage.

Note: Non-professionals are not allowed to disassemble the fire extinguisher on their own, to avoid the occurrence of accidents.

Caution

- Each fire extinguisher shall be inspected annually as of the manufacture date of vehicle. The fire extinguishing agent must be replaced every two years and the fire extinguisher must be replaced every ten years.
- The annual inspection and post-usage repair must be performed by an enterprise approved by Fire Department and having relevant qualifications to test, repair and annually inspect fire equipment.
- The vehicle owner is obliged to inform the purchaser of the aforesaid precautions if the vehicle is sold.

Vehicle tools

The vehicle tools are placed at the bottom of the luggage compartment(for vehicles with three rows of seats) or behind the second row of seats(for vehicles with two rows of seats).

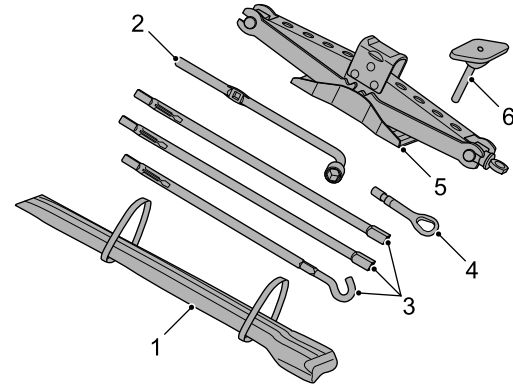

- 1 Vehicle toolkit
- 2 Wheel nut wrench
- 3 Auxiliary rotating extension rod of jack
- 4 Rear towing eye
- 5 Jack
- 6 Jack fixing screw (It is suitable for 4 seats or 5 seats models.)

Before You Drive

MP3+Radio

Panel features description

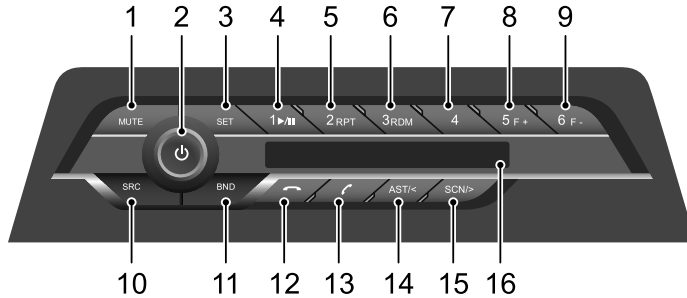

- 1 Mute Button
- 2 PWR/VOL: Power On/Off button
Volume adjustment knob
- 3 System Setting Button
- 4 Preset Button 1/ Pause Button
USB track confirmation function: Press to enter playback state
- 5 Preset Button 2/ Repeat Playback Button
- 6 Preset Button 3/ Random Playback Button
- 7 Preset Button 4
- 8 Preset Button 5/ Next Directory(USB mode)
- 9 Preset Button 6/ Previous Directory(USB mode)
- 10 Audio Source Selection
- 11 Radio Band Selection
- 12 Hang up the incoming Bluetooth call
Disconnect the Bluetooth device(long press)
- 13 Answer the incoming Bluetooth call
Activate the Bluetooth device(long press)
- 14 Search radio stations at lower frequency
Automatic Station Storage(long press)
Select previous track(USB mode)
Fast rewind(USB mode) (long press)
- 15 Search radio stations at higher frequency
Radio Station Browse(long press)
Select next track(USB mode)
Fast forward(USB mode) (long press)
- 16 DISPLAY Interface

Audio adjustment

Power On/Off

With the ignition switch in ACC or ON, short press the PWR/VOL button to turn on the unit, and short press the button again to turn off the unit. With the ignition switch in OFF, long press the PWR/VOL button to turn on the unit, and it will be turned off automatically after operating for half an hour, then repeat this cycle.

Clock Setting and Display

Long press the SET button, then short press it to select the adjustment menu: BEEP (touch-tone) / selection of countries and regions/ Clock.

- In the BEEP state, enter the touch tone selection mode by short pressing the SET button. Select either ON or OFF by rotating the PWR/VOL knob.
- In the Selection of Countries and Regions state, rotate the TUN/AUD knob to select different country or region.
- In the CLOCK state, short press the SET button, the Hour or Minute field begins to blink, rotate the PWR/VOL knob to make the setting, the clock begins to run from the adjusted time.

It will enter the clock screen automatically after 8 seconds if the RADIO is not operated.

Volume

Rotate the PWR/VOL knob to adjust the volume. For safety reasons, please choose the proper volume to ensure that you can still hear the external traffic signal sound (whistle, police whistle, etc).

Audio / EQ Mode Adjustment

Short press the SET button to enter the EQ Setting mode:

Rotate the PWR/VOL knob for setting, then short press the PWR/VOL knob again to enter the next setting mode.

- Enter the EQ mode BASS-TRE to select preset EQ type. Rotate the PWR/VOL knob to select different EQ modes: JAZZ/CLASSIC/VOCAL/ROCK/POP. The display will show the selected EQ after the selection. Such as JAZZ.
- In BASS setting, rotate the PWR/VOL knob to adjust the Bass effect, adjusting range: BASS-7, ..., 0, ..., BASS+7.
- In TREBLE setting, rotate the PWR/VOL knob to adjust the TREBLE effect, adjusting range: TREB-7, ..., 0, ..., TREB+7.
- In BAL setting, rotate the PWR/VOL knob to adjust the volume balance between right and left speakers, adjusting range: L7, ..., MID, ..., R7.
- In FADER setting, rotate the PWR/VOL knob to adjust the volume control of front and rear speakers, adjusting range: R7, ..., MID, ..., F7.

In the digital adjustment mode, all default values are 0. The display will return to the previous operating mode automatically after about 10 seconds.

Before You Drive

Radio reception

Band

Press BND button to select the desired band. The band can be switched among FM1, FM2, FM3, AM1, AM2, then the system will display the selected band.

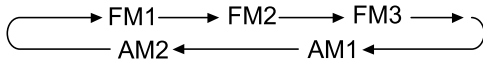

Automatic Station Search

Short press the AST/◀ button to tune to stations at lower frequency.

Short press the SCN▶ button to tune to stations at higher frequency.

Automatic Station Storage

Short press the AST button in FM1-3 bands to save 6 FM stations with strongest signal, or short press the button in AM 1-2 bands to save 6 AM stations with strongest signal. If you are using the Automatic Station Storage function, the previous stations stored in FM 1-3 bands or AM 1-2 bands will be overwritten.

You can store 6 FM stations with strongest signal in FM 1-3 bands or 6 AM stations with strongest signal in AM 1-2 bands. If you are using the Automatic Station Storage function, the

previous stations stored in FM 1-3 bands or AM 1-2 bands will be overwritten.

Long press the AST/◀ button to enter the Automatic Station Storage state, then:

- The display begins to blink.
- It stops blinking after saving.
- The stations are stored to the preset button 1-6.
- The saved stations may be less than 6 when the external radio signal is weak.

Preset Stations

Manually store the stations to the preset button 1-6.

6 stations can be stored in each band with the preset button 1-6.

- Tune to desired station
- Press and hold the desired preset button at least 2 seconds, then the current station can be stored to this preset button.

Recall Preset Station

Press the desired preset button 1-6 once to recall the preset station.

Playing in USB mode

There is no external USB port on the player panel, the USB port is located on the floor console, which can be connected with your U disk or portable media player.

File Decoding Instructions

- Support the audio files with the suffix of *.mp3, *.MP3 or *.WMA.
- Support the USB storage devices of 32Mbyte ~ 4G, which takes the flash memory as storage medium.
- Connect with the USB storage devices that are partitioned in FAT16 and FAT32 file system format.
- Supported sampling frequency range: 8k, 16k, 32k, 11.025k, 22.05k, 44.1k, 12k, 24k, 48kHz.
- Supported Bit Rate: 8k ~ 320kbp, VBR(MP3 PRO).

Device Connection

Please insert your USB storage device into the USB port, press the SRC button to select the USB mode, then LCD will display the word "USB".

Caution

The player is to be initialized to search for MP3 files as the USB storage device is just connected, the waiting time is ranging from a few seconds to more than 10 seconds, depending on the different capacities of USB storage devices and the sizes of its saved files, so do not remove the USB hurriedly during this period.

Playing

The screen will display the following items during normal playback: EQ mode (if selected), current USB track no., elapsed time.

When all tracks in the previous folder are played, the unit will skip to the first MP3 file in the next folder automatically in order.

Repeat playback

Press 2/RPT button during the playback to play the current track repeatedly; the repeat playback of single track and folder is supported.

Press the button again to return to the normal playback state.

Random playback

Press 3/RDM button during the playback to play the tracks in current folder randomly.

Press the button again to return to the normal playback state.

Before You Drive

Fast Forward/Rewind Playback

Long press the SCN/▶ button during the playback to fast forward the track from the current playback node.

Long press the AST/◀ button during the playback to fast rewind the track from the current playback node.

Short press the 1/⏮ button to return to the normal playback state.

Previous / Next Track

Short press the AST/▶ or AST/◀ button to select next or previous track.

Pause

Short press the 1/⏮ button during the playback, the head unit will pause playing, and press it again to continue playing from the pause point.

USB Directory Selection

Press 5/F+ to enter the next Directory (directory no. increases) in the USB for playing.

Press 6/F- to enter the previous Directory (directory no. decreases) in the USB for playing.

Caution

- The USB port of this unit supports to charge external devices whose voltage is within the following range (e.g. mobile phone charging). The charging voltage range is 5+/-0.5V, the charging current is 500mA, and the charging logic is: charging is possible when the RADIO is On, and impossible when the radio is Off.
- If your device can not be recognized or played correctly when inserted into the USB port, please remove and insert your USB device again and ensure that the USB port keeps good contact and is not obstructed by abnormal objects, such as dust.

Bluetooth

The Bluetooth connection between the mobile phone and the system must be completed before operating the system. This connection is based on the mating connection between the mobile phone and the system. The system will store the mobile phone's ID once the pairing connection is established. When the vehicle is started or the system is turned on, it will connect to the mobile phone automatically as long as the Bluetooth switch is turned on. After establishing the connection, you can make calls via the on-board audio system and the microphone.

This system supports 8 Bluetooth pairings, but only the current connected device is activated.

Caution

- The Bluetooth pairing requires your mobile phone supporting HFP (Hands-Free Profile) Bluetooth application protocol. The establishment of Bluetooth connection varies with the mobile phone manufacturers. Refer to the mobile phone's User Guide for more information.
- If your mobile phone is provided with the navigation feature, after the Bluetooth connection is established, the navigation prompt tone for some types of mobile phone can be broadcast via the onboard audio system. This feature needs to be supported by your mobile phone. For the mobile phones that do not support this feature, their navigation prompt tone will be broadcast via the mobile phone.
- For some types of mobile phone, the touch tone will be transmitted via Bluetooth when the Bluetooth connection is established. If you do not want hear the mobile phone's touch tone from the car radio, you are recommended to turn off this tone.

Before You Drive

Bluetooth Connection

Long press "Answer Incoming Bluetooth Call" button to enter the Bluetooth pairing mode. The radio display will display the word "PHONE" for 2 seconds. Set your phone to the search mode at this time to find out the Bluetooth name of "Vision Car BT xxxx".

After entering the Bluetooth pairing mode by long pressing the "Answer Incoming Bluetooth Call" button, the icon will blink if no device is connected, and stays ON after the successful device pairing.

The pairing can be made after the Bluetooth module is found. The Bluetooth module can be paired with up to 8 phones, if the phone number exceeds 8, the memory for the oldest paired phone will be deleted so as to maintain the memory for 8 pairing phones.

Establish the connection with the mobile phone after the successful pairing. When the Bluetooth connection is established, the radio will display the word "PHONE" for 2.5 seconds, and the Bluetooth module can only be connected to one phone simultaneously.

Long press the "Hand up Incoming Bluetooth Call" button 2 seconds to disconnect the phone connection automatically.

Answering and Rejecting Incoming Calls

After the connection is established, when there is an incoming call, the radio will display the word "PHONE", and the incoming call ring tone will sound. Short press the "Answer Incoming Bluetooth Call" button to answer the call, and short press the "Hand up Incoming Bluetooth Call" button to reject the incoming call.

Note: If IPHONE is connected, RADIO will sound the default IPHONE ring tone when answering the calls, if the Android phone is connected, RADIO will sound the "Jingling" ring tone.

Hands Free / Private

When talking on the phone, the bluetooth interface box will output the sound to the audio in hands free form and show the word "PHONE" in the radio display. The calls can be switched between hands free and private by pressing "Answer Incoming Bluetooth Call" button.

Hang up

When talking on the phone, the current call can be hung up by pressing "Hand up Incoming Bluetooth Call" button.

Before You Drive

Redialing of Latest Number and Disconnection

Redialing of Latest Number

After the connection is established, long pressing the "Answer Incoming Bluetooth Call" button will dial the last dialed number in the phone records and the display screen will show the reminder with the word "call out" and the outgoing call number.

Disconnection

After the connection is established, long pressing "Hand up Incoming Bluetooth Call" button will disconnect the connection between the current phone and the on-board bluetooth and turn off the Bluetooth, when the connection is disconnected, the radio will display the word "PHONE" for 1 second.

Automatic Reconnection

The connection will be disconnected if the distance between the phone and the vehicle exceeds the connecting distance; when the phone gets back to the connection range, the phone will be reconnected with the external Bluetooth module automatically. When the external Bluetooth module is powered on, it will reconnect with the last connected phone automatically.

"Answer Incoming Bluetooth Call" button

Under this situation ...	Short press Answering button ...
External calls	Answering Incoming Calls
Talking (Hand free mode)	Enter private mode
Talking (Private mode)	Enter hands free mode

Under this situation ...	Long press Answering Button ...
Standby (not pairing)	Bluetooth module enters visible mode
Standby (connection completed)	Dial the last dialed number in the call records

"Hand up Incoming Bluetooth Call" button

Under this situation ...	Short press Hang Up button ...
External calls	Rejecting
Talking (Hand free / Private)	Hang Up

Under this situation ...	Long press Hang Up button
Standby (connected)	Disconnect Bluetooth connection

Before You Drive

AUX IN interface

There is no external AUX IN port on the player panel, but a standard audio interface of 3.5mm is reserved on the floor console, you can connect an audio playback device with a corresponding audio adapter. When the audio device is connected, press the SRC button to select the AUX IN mode. In AUX IN mode, you can adjust the music volume with the volume adjustment knob.

Volume during reversing

When it is reversing, the infotainment system is controlled by the reversing lines, so the volume of all sound sources will be reduced, then the volume of original source will be resumed when the reversing is completed.

For vehicles with automatic transmission: if the shift lever is in "R (reverse)" position, the volume of all sound sources will be reduced, if it is shifted out of "R (reverse)" position, the volume of original source will be resumed.

Before You Drive

Common troubleshooting

If you find some features of the car audio are inoperative, please read the operating guide in this manual carefully before sending it to repair, then make the inspection according to the following table, this contributes to the troubleshooting.

1

Symptoms	Possible Causes and Solutions
General Conditions	
The unit is inoperative and not displaying	The fuse of unit power supply or vehicle is blown, ask Service Dealer to replace it with the correct type of fuse.
The unit is operative, but with no sound or little sound	Volume up; Check the speaker's BAL and FADER.settings
The unit body is a little hot	It is normal when the unit is operating.
Radio reception	
Poor radio reception	The antenna amplifier in the vehicle may be damaged, please ask Service Dealer to check it. The signal of the desired station is too weak, please tune it manually.
USB Device Playback	
Some audio files can not be played	Please confirm that it is a MP3/WMA file, this unit does not support audio files in formats other than MP3/WMA.
The volume ups and downs when playing MP3 tracks	The sources of MP3 tracks are extensive and have no unified standard, so the inconsistent volume may be set during the compression of MP3 tracks, now you should adjust the volume knob.

Before You Drive

Symptoms	Possible Causes and Solutions
Artist/Track/Title can not be Displayed	This unit does not support the ID3 information display.
The music pauses intermittently during playback	This may be caused by the different compression formats.
Unable to read the tracks in the external hard drive	Confirm that the hard drive has only one partition, as this unit does not support the multiple disk partitions. If two or more disk space have been set, such as E and F disks, or more disk space, this model can not read the MP3 tracks in these disks. If you want to use it, please combine all disk space into one on your computer.
Unable to read the tracks in the storage device	Confirm that this storage device is partitioned in FAT16 or FAT32 format when inquiring on the computer, if not, it can be reset to the standard required by this unit on the computer.
Unable to read MP3 tracks through USB hub	This unit only supports the adapter with one USB port.
Violent Tone/ Noise	This may be caused by the device used to record the original MP3 files and the noise, determine if it is this unit's problem with other player.

Caution

If the failure still exists, take your vehicle to our Service Dealer for service. Do not disassemble the car audio for repair without authorization.

MP5+Radio

Precautions before use

For the instructions of MP5+Radio in the vehicles, please refer to the operating instructions accompanied with the entertainment head unit.

Please read carefully and fully understand the operating instructions accompanied with the entertainment head unit before you use this product.



Please do not install or repair your product without authorization.

If the product is installed or repaired by a person who does not receive the training on electronic equipments and auto parts, a dangerous situation may be posed.

According to the relevant national regulations, watching videos and related operations are prohibited during driving for the personal safety of yourself and others. Please do not watch the screen and make related operations when driving a vehicle.

Never expose the product to any liquid, otherwise short circuit or damage may be caused.

The rear view camera function of the system just serves as a driving aid, please pay attention to the actual situation.

Caution

- The product shall be kept away from moisture.
- Be sure to drive safely.
- Make sure to follow the rules of safe driving and existing traffic regulations.
- Do not do that if the operation of this product (and the rear view camera function) may have your attention diverted when you are safely driving.
- If you have to operate by viewing the screen, please park the vehicle at a safe place and apply the parking brake.
- Do not set the volume of the product too high, or you will not hear the traffic conditions and emergency rescue signals outside.
- For the sake of safety, some features, such as video playback, will be disabled when driving.
- The system can detect the running speed of the vehicle. When the speed exceeds a certain value, the system will prevent you from watching a video when you drive. If you want to watch a video, please park the vehicle in a safe place and apply the parking brake.
- To prevent battery drain, please make sure to start the vehicle when the system is used.

Before You Drive

MP5+Radio (Type 1)

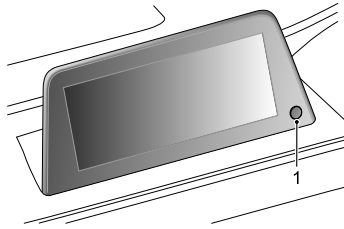

1 HOME Button

Main interface mode, long press for 3 seconds to turn off and long press for 10 seconds to reboot.

Introduction and operation of main interface function



1 Displaying device connection status

The connection status of Bluetooth and USB is displayed. When they are connected, the corresponding icons will be

highlighted. If they are not connected, the relevant icons will not be displayed.

2 Time display

The current system time is displayed.

3 Volume button

The current volume information is displayed. Touch this button to show the volume bar. Slide the volume bar can directly adjust the volume.

4 Vehicle state mode icon

Touch the vehicle state mode icon to enter the vehicle state interface to operate.

5 Contact mode icon

Touch the contact mode icon to enter the contact mode to operate.

6 Main menu mode icon

Touch the menu icon to operate Carplay, A/C, MirrorLink and App, settings.

7 Radio mode icon

Touch the radio mode icon to enter the ratio interface to operate.

8 Multimedia mode icon

Touch the multimedia mode icon to enter the multimedia interface to operate.

Before You Drive

MP5+Radio (Type 2)

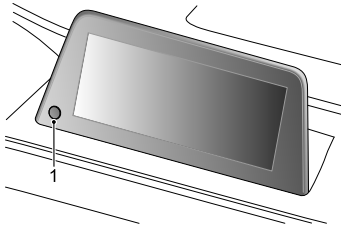

1 HOME Button

In main interface mode, long press for about 3 seconds to power off, then press for about 10 seconds to restart.

Introduction and operation of main interface function

Status bar



- 1 Time display
- 2 Current playback display
- 3 Bluetooth/USB/wifi connection display
- 4 Volume display

Application Center

For the related guide, we prepare for a user manual on the homepage of the screen. Please click and see.

- 1 Click the central icon on the bottom.

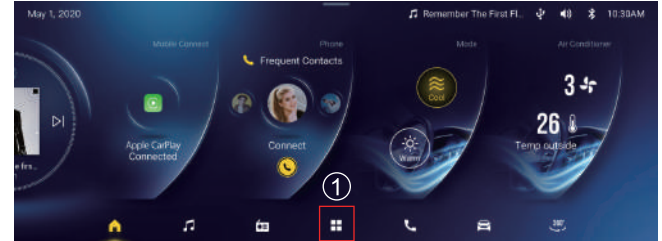

- 2 Click the User Manual.

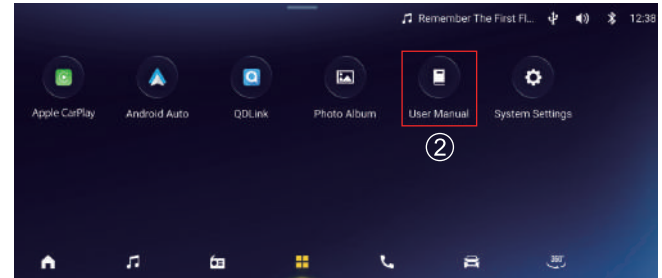

1

Before You Drive

Common troubleshooting

Symptoms	Possible Causes	Solution
Screen Too Dark	Improper Brightness Setting	Enter the screen setting to adjust the brightness of screen.
	Vehicle Headlamp Normally ON	Vehicle Headlamp OFF
Not Power On	Appliance Power Supply or Vehicle Fuse Blown	Please ask Service Dealer to replace it with the fuse of correct type.
No Sound Output	Unit Mute	Short press the mute button on the steering wheel or short press the mute icon on the top.
	When playing a video, you have returned the directory, homepage or entered the setting interface.	The video is in pause state at the moment, then enter the video interface to continue to play.
Bluetooth music mode mutes	It is switched to Bluetooth music but not playing.	Play Bluetooth music from your mobile phone or short press the play button on Bluetooth music.
Low Volume	The volume is adjusted to a low level.	Operate Volume + button to adjust volume.
	The channel balance position is far away from the center.	Enter the setting to adjust the channel balance position to the center.
The radio cannot find valid stations.	The radio antenna is not properly connected.	Connect the radio antenna properly.
A USB flash disk is inserted but it's failed to enter USB mode.	The USB flash disk has poor quality.	Make sure that the USB flash disk is original and quality-assured.
	There is no any audio, video or image resource in the USB flash disk.	Check the USB flash disk for any available media content.

Before You Drive

1

Symptoms	Possible Causes	Solution
Slow response after inserting the USB flash disk.	The USB flash disk has poor quality.	Make sure that the USB flash disk is original and quality-assured.
	The capacity of USB flash disk exceeds the limit of 32G.	Please use the USB flash disk with a capacity within 32G.
	The hierarchical arrangement of folders is too complex and there are too many folders.	Clean up the USB flash disk to guarantee a clear hierarchical arrangement of folders in the USB flash disk.
	There are large capacity files in the USB flash disk.	Clean up the USB flash disk and remove the large capacity non-media files.
A reminder is given that the audio or video file is not supported, it gets stuck or mosaic or no playing, etc happens.	The audio or video file is damaged.	Ensure that the audio or video can be played normally on the home computer.
	The video resolution exceeds 1920*1080 and the bitstream is over 50M/S.	Be sure that the playing file is within the set range.
	Non-video DAT File	DAT is a special format, which is classified into video format and data format. The DAT file of data format is not supported.

Caution

If the failure still exists, take your vehicle to our service dealer for service. Don't disassemble the on-board entertainment system for repair by yourself without authorization.

Starting and Driving

- 126 Before Starting and Driving
 - 126 Ignition Switch
 - 129 Keyless Start System
 - 131 Engine Immobilizer System
 - 132 Start/Stop the Engine
 - 133 Intelligent Start/Stop System
 - 136 Driving
 - 138 Catalytic converter
 - 142 Fuel
 - 146 Manual Transmission
 - 147 6AT Automatic Transmission
 - 149 8AT Automatic Transmission
 - 158 Electric Power Steering Device
 - 159 Four Wheel Drive System
(4WD)
 - 166 Electronic Differential Lock
 - 167 Brake System
 - 176 Constant Speed Cruise
Control System
 - 179 Parking Assist System
 - 186 Driver Assist System
 - 214 Tires
 - 216 Loading
-

Starting and Driving

Before Starting and Driving

- Conduct daily/weekly maintenance checks on the vehicle in accordance with the provisions in Maintenance - Owner Checks.
- Ensure seats are in correct positions through check.
- Ensure all rearview mirrors are adjusted to correct positions through check.
- Ensure all lighting, signal systems and warning indicators operate normally.
- Ensure all passengers have fastened their seat belts correctly through check.

Move the ignition switch in "ON" position, and ensure all warning lamps and gauges operate normally through check. Please refer to "Warning Lamps and Indicator Lamps" in the Before You Drive section.

Caution

Before reading this chapter, please make sure you have read the Before You Drive section in this manual and you have been familiar with your vehicle and on-board equipment.

Ignition Switch

Key start



Do not pull out the key during driving. Otherwise you will lose control of vehicle direction.

Be sure to pull out the key after turning off the ignition switch, especially when you plan to get off and leave a child alone in the vehicle.

Do not coast down with the ignition switch off, because the assistance of brake booster and power steering device will not be provided in this case.

Note: Your vehicle has been installed with the engine immobilizer system. Please refer to "Engine Immobilizer System" in this section.

The ignition switch has the following positions:

LOCK: The ignition switch is off. You can insert or pull out the key only when the ignition switch is placed in this position. After the key is pulled from LOCK position, the ignition switch will lock steering columns to prevent the steering wheel from rotating.

ACC: Steering columns are unlocked, and individual electric appliances and accessories can operate, such as radio and cigarette lighter.

Note: You may need to slightly rotate the steering wheel to unlock the steering lock.

Starting and Driving

Note: Do not leave the key in ACC position for a long time, so as to prevent unnecessary battery power loss.

ON: The ignition switch is on, and all instruments, control devices and circuits can operate.

Note: When the engine is not running, do not leave the key in ON position.

START: The starter motor runs and engine is started. After the engine is started, release the key immediately, and the key will automatically return to ON position from START position.

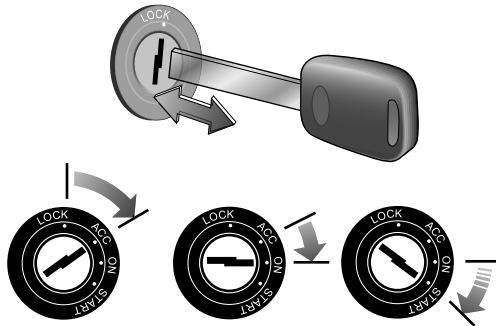

Keyless start

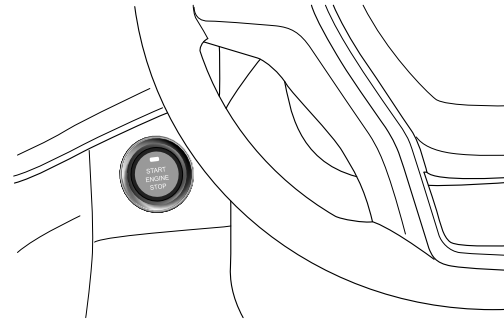

Note: The vehicle is equipped with electronic hands-free key ignition switch, that is, the start-stop switch for button-type start. To start the vehicle, the PEPS must be in the vehicle. For an AT model, if you want to move the shift lever out of P, you must depress the brake pedal with the ignition switch in ON position.

ACC - red lamp

- Start Failure
- Abnormal Parking

In case of engine start failure, the ignition switch will switch to ACC.

When the engine is running and the shift lever is not in N gear (for MT model) or P gear (for AT model), press this button and ignition switch will switch to ACC.

Starting and Driving

- Emergency Flameout

When the vehicle speed is higher than 5km/h during driving, press the ignition switch for 3 times continuously or long press it for 3s, the ignition switch will switch to ACC.

Note: Red lamp flashing 3 times indicates that a legal physical key/Bluetooth key is not detected in the vehicle.

ON - green lamp

When the engine shuts down and the starting conditions are not met, press this switch once, the ignition switch will switch to ON; after the engine is normally started, the ignition switch will switch to ON; when in ON state, all instruments, control devices and circuits can operate.

Note: If the ignition switch is still placed in ACC or ON position after engine shutdown, the battery power will be drained. The vehicle may be unable to start if the battery power drain time is too long.

START - green lamp

This position is used for starting the vehicle. When the engine shuts down, there is an effective remote key in the vehicle and the starting conditions are met, press and release this button, and then engine will be started.

Starting conditions:

- Manual Transmission

Place the shift lever in N position.

Depress the clutch pedal all the way down and hold.

- Automatic Transmission

Place the shift lever in P or N position.

Depress the brake pedal and hold.

OFF

This position shuts down the engine. When the shift lever is placed in N (for MT model) or P (for AT model) position, press this switch and the ignition switch will switch to OFF.

Caution
When the vehicle is close to strong radio antenna signals, there may be an interference effect on the remote door lock system and the start-stop switch will not work.

Keyless Start System

Keyless unlocking

When all doors are locked, enter the sensing area with a remote key and press the microswitch, the central lock will unlock automatically. After unlocking, direction indicator lamps will flash twice. If you do not conduct any of the following operations within 30s after that, the central lock will automatically lock again:

- Open any door
- Shift the power supply position to a non-OFF position
- Operate the central lock to unlock/lock

Note: It is feasible to unlock doors with the central unlocking button on the remote key. Press the central unlocking button once, and the central lock will unlock automatically.

Keyless locking

When the driver's door or front passenger's door is unlocked, enter the sensing area with a remote key, and then press the microswitch on the door handle. The direction indicator lamps will flash once, meanwhile the alarm horn will ring once for a short time (as appropriate). Then all doors will be locked, meanwhile the vehicle enters the fortification state. In any of the following cases, the doors will not be locked after the microswitch is pressed:

- The power supply switch is placed in non-OFF position

- The remote key is left in the vehicle
- The remote key is not in the sensing range
- The remote key battery is low
- The driver's door is open

Note: It is feasible to lock doors with the central locking button on the remote key. Press the central locking button once, and the central lock will lock automatically.

Keyless start

When the remote key is left in the vehicle and the starting conditions are met, press the start-stop switch once at this time, and then the engine will be started. Starting conditions:

- Automatic Transmission

Place the shift lever in P or N position.

Depress the brake pedal and hold.

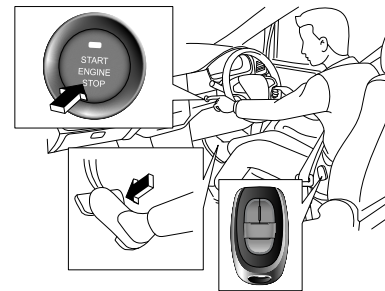

Starting and Driving

Note: *If the starting conditions are not met, every time you press the start-stop switch, the power supply positions will be switched among OFF, ACC and ON in a cycle. If the remote key is not in the vehicle, after depressing the brake pedal, the indicator lamp will not illuminate, and the power supply position switching or ignition action will not be performed after the start-stop switch is pressed.*

Backup starting

When the remote control battery is low, the keyless entry function will fail, but you still can start the engine. Open a door with the mechanical key and enter the vehicle. At this time, the system may be in IMMO state and the alarm may be triggered, which is a normal situation.

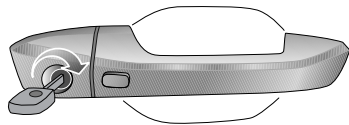

On the premise of meeting starting conditions, lay the key flat in the position with an identification in the storage box which is in front of the central armrest and press the start-stop button. Then the engine can be started.

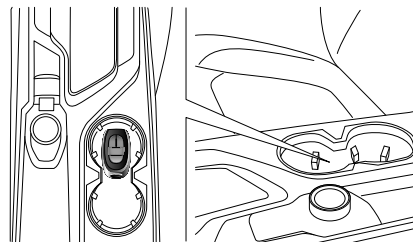

Emergency flameout

If you need to shut down the vehicle immediately during driving due to an emergency, there are two methods to shut down the engine:

- 1 Keep pressing the start-stop switch within 3s.
- 2 Press the start-stop switch for continuous 3 times.

Engine Immobilizer System

Keys

The keys have been coded electronically for your vehicle. The coded keys can be used for the corresponding vehicle only. Only the keys attached with the vehicle can start your engine.

For a vehicle equipped with the PEPS system, its engine can not be started only when the remote key is in the vehicle.

When the immobilizer system is effective, any illegal behavior to start the engine will be prohibited.

Enable/disable

When the key is switched from LOCK position to ON position, if the authentication succeeds, the IMMO warning lamp (yellow) on the instrument cluster will keep off for a long time. If the IMMO warning lamp (yellow) flashes, it is shown that the immobilizer system goes wrong and the engine cannot be started. Contact a service provider authorized by the Company for overhaul immediately.

For a vehicle equipped with the PEPS system, when the start-stop switch is placed in ON position, if the authentication succeeds, the IMMO warning lamp (yellow) on the instrument cluster will keep off for a long time. If the IMMO warning lamp (yellow) flashes, it is shown that the immobilizer system goes wrong and the engine cannot be started. Contact a service provider authorized by the Company for overhaul immediately. If the remote key is not in the vehicle or there is certain interference, the information center on the combination cluster will display the prompt "Key not in the vehicle". If the battery of remote key shall be replaced, the information center on the combination cluster will display the prompt "Please replace the battery of remote key". Please replace the battery of remote key as soon as possible.

Note: *The remote key contains a microchip which guarantees the fault-free data exchange between the key and the vehicle. Do not shield the key with a metal object (such as another key). Prevent it from severe impact. The quantity of keys hung on the keyring shall not exceed 1.*

Starting and Driving

Start/Stop the Engine

Starting



CO is a harmful gas and may cause coma, even death. Avoid inhaling vehicle exhaust because it contains colorless and odorless CO. Do not start the engine or keep the engine running in an airtight and unventilated place. If you find there is exhaust in the vehicle, find out the cause as soon as possible and correct. If you have to operate in this kind of environment, please open all windows completely.

- Manual Transmission

Place the shift lever in N position.

Depress the clutch pedal all the way down and hold.

- Automatic Transmission

Place the shift lever in P or N position.

Depress the brake pedal and hold.

Vehicles with Gasoline Engine

Turn the key to START position to start the engine. After the engine begins running, release the key immediately, and the ignition switch will automatically return to ON position.

For vehicles equipped with the PEPS system, please refer to "Ignition Switch" and "Keyless Start System" in this section.

Note: During starting, do not keep the starter running for 10s above. If the engine is not started, wait for at least 30s after turning off the ignition switch and try again.

Vehicles with Diesel Engine

Place the ignition switch in ON position, and wait for the "glow plug indicator lamp (yellow)" on the instrument cluster to go off. Turn the key to START position to start the engine. After the engine begins running, release the key immediately, and the ignition switch will automatically return to ON position.

For vehicles equipped with the PEPS system, please refer to "Ignition Switch" and "Keyless Start System" in this section.

Note: During starting, do not keep the starter running for 10s above. If the engine is not started, wait for at least 30s after turning off the ignition switch and try again. As the ambient temperature declines, the engine starting time may increase correspondingly. Therefore, please turn off all unneeded electrical appliance temporarily during starting. At a weather with the temperature below -25 °C, please park the vehicle in the garage.

Caution

Avoid high-speed and full-throttle running before the engine reaches the operating temperature.

Starting and Driving

Warm-up

When the engine temperature is relatively low, there will be a poor effect if the engine is warmed up with the vehicle in stationary state. It is recommended to drive the vehicle as soon as possible after the engine is started.

Self-protection mode

In case of an engine fault which may affect driving performance during driving, the engine system will enter the "self-protection mode". In this case, the "engine MIL (yellow)" on the information center display screen will start flashing or stay on. Please contact Service Dealer for service immediately.

Shutdown

Turn the ignition switch from ON to OFF position to shut down the engine.

For vehicles equipped with the PEPS system, please refer to "Ignition Switch" and "Keyless Start System" in this section.

Pull up the parking brake handle.

Caution
For vehicles equipped with diesel engine, keep the engine idling for 10s before shutdown, in order to ensure the turbocharger bearing is fully lubricated during the deceleration.

Intelligent Start/Stop System

Note: *It is suitable for vehicles installed with intelligent start/stop system.*

Basic conditions of usage

The intelligent start/stop system can help to save fuel consumption and reduce CO2 emission. When the intelligent start/stop system is in use, if the vehicle is stopped at a red light, the engine will be shut down automatically when the vehicle is stationary. During the engine stop period, the ignition switch remains On. When necessary, the engine will be automatically started again. When the ignition switch is turned on, the intelligent start/stop system will be activated automatically.

2

Starting and Driving

Basic conditions of usage for the intelligent start/stop system:

- The driver door has been closed.
- The driver has fastened the seatbelt.
- The engine hood has been closed.
- The vehicle travels at a speed of above 10km/h from the last stop.

Note: The engine has been shut down before the vehicle is about to enter in stationary state. However, the full functions of brake booster system and power steering system still can be guaranteed.

Caution

When driving across water, the driver should always keep the intelligent start/stop system inactivated.

Shutdown and startup of engine

Vehicles with automatic transmission

Please conduct a full braking to the vehicle; after the vehicle is stationary, keep depressing the brake pedal to shut down the engine (engine stop phase). Meanwhile, the “Intelligent



Start/Stop System Indicator Lamp (green)” on the information center of the instrument cluster illuminates.

Once the brake pedal is released, the engine will be started again. If the parking assist function is activated, the engine will re-started only when the accelerator pedal is depressed. The indicator lamp goes out.

Additional information about the vehicle with automatic transmission

- Only when the shift lever is in D position will engine be shut down.
- If the shift lever is moved out of the D position during the engine stop phase, the engine will be started again.
- Regardless of whether the engine is shut down or not, you can reduce or increase the braking force at your own. For stop-and-go driving or cornering, if the brake is slightly depressed, the engine will not stop while the vehicle is stationary. Once the brake pedal is depressed hard, the engine will be shut down immediately.

Starting and Driving

Caution

When the engine is shut down, please depress the brake pedal to avoid vehicle slip. If the engine intelligent start/stop system switch^(A) on the floor console is pressed during the engine stop phase, the engine will get started automatically. If the driver door is opened or the driver seat belt is unfastened, the engine will not get started automatically; to start the engine, please move the shift lever to P or N position, and then start the engine with the start button or key.

Instructions

Normal intelligent start/stop action may be interrupted due to different system conditions.

The engine is not shut down

Before and during the engine stop, the system will check whether the particular conditions have been met. Under any of the following circumstances, the engine will not be shut down:

- The engine has not yet reached the minimum temperature at which the start/stop system can operate.
- The windshield is being defrosted.
- The battery charging status is too low.
- After the replacement or reconnection of the battery, the vehicle is not locked for more than 4h.
- The shift lever is not in the D position.
- The slope is very steep.
- The altitude is very high.
- The braking vacuum is insufficient.
- The engine MIL/ESP MIL illuminate.

When the start/stop conditions are not met, the “Intelligent

Start/Stop System Indicator Lamp (white)”  illuminates.

The engine gets started again automatically

During the engine stop phase, under any of the following circumstances, the normal start/stop operation will be

Starting and Driving

interrupted. The engine gets started again without the action of the driver.

- The vehicle rolls like on a slope.
- The windshield is being defrosted.
- The battery charging status is too low.
- High current consumption.
- The braking vacuum is reduced.

If the conditions for intelligent start/stop operation are met again, the engine may be shut down again.

Caution

- On vehicles equipped with automatic transmission, if you shift to D gear after moving into reverse gear, then you must drive the vehicle at a speed of 10 km/h first to facilitate the system's shutdown of the engine again.
- If you do not want to use the system, you can turn it off manually. Press the engine intelligent start/stop system switch^(A) on the floor console, the start/stop system will be turned off; and then the dialog box that "Start/Stop System Off" will be displayed in the information center of the instrument cluster.
- When the "Intelligent Start/Stop System Indicator Lamp (yellow)"  illuminates, it indicates that the system has a malfunction! The function is disabled.
- The intelligent start/stop system has a malfunction. Please contact our Service Dealer for troubleshooting.

Driving

"Running-in" of new vehicle

The vehicle does not need intentional "running-in". In order to improve the long-term operating performance of the vehicle, we strongly recommend that you abide by the following points:

Within the first 3,000km:

- Avoid driving fast and frequent shifting.
- Do not depress the accelerator pedal all the way down at any gear.
- Do not keep the engine run slowly with difficulty at any gear.
- Please try to avoid using the emergency brake excessively.

After the mileage reaches 3,000km, you can gradually increase the vehicle speed to the maximum admissible speed.



Avoid using high engine speed to protect the engine, reduce fuel consumption, lower engine noise level and protect the environment.

Starting and Driving

Driving

 **During driving, do not place any portable container filled with fuel in the vehicle. Otherwise a fire may occur due to leakage.**

Caution

During driving, do not place your foot on the clutch pedal for rest; otherwise the clutch may be worn/damaged.

When driving on a risky road covered with water, snow, ice, mud, sand, etc., please:

- Slow down, drive with care and reserve longer brake distance.
- Avoid any sudden operation during braking, steering or acceleration.
- Apply sand or other anti-skid material under the driving wheels or install tire chains on them to provide the traction needed when the vehicle gets stuck in ice, snow or mud.

Skid

If your vehicle skids on a wet road, you cannot control the vehicle due to the decrease of friction force between the road and tires. Different road surfaces, tire inflating pressures and vehicle speeds may lead to skid. Skid is very dangerous.

The optimum method to stop skid is lowering driving speed and keep cautious when you feel the road is wet enough.

Wading driving

In order to avoid damage to your vehicle, when passing a road with gathered water, please:

- Confirm the water depth before the wading driving. The maximum wading depth of the vehicle is 55cm.
- The driving speed shall not be greater than 10km/h.
- The wave caused by front vehicle and head-on vehicle may exceed the maximum allowed wading depth.
- To avoid vehicle damage, please drive away from the road with puddles as quickly as possible.

Caution

If the engine is shut down in the water by accident, do not restart the engine by yourself, please contact our Service Dealer immediately. When driving across water, the driver should always keep the intelligent start/stop system inactivated.

Starting and Driving

 Water and mud can affect the braking system and lengthen braking distance, leading to an accident!

- Slightly depress the brake pedal to keep brake parts dry and recover performance.
- Do not conduct an emergency brake when passing a slippery road.

Note: The engine, drivetrain, transmission and electronic system of the vehicle may be severely damaged after the vehicle drives on a road with puddles. Salt water is corrosive. The on-board components soaked by salt water must be washed with clean water.

Catalytic converter

 The catalytic converter will release a lot of heat (even within a short time after engine shutdown), which may cause a fire.

Do not operate or park the vehicle on any flammable object (such as paper, dry grassland or dry fallen leaves).

When the engine is running or after it is shut down within a certain period, and before the catalytic converter cools down, prevent any body parts from contacting the exhaust system.

The catalytic converter installed in the exhaust system is used for reducing exhaust pollution.

Caution

In order to protect the catalytic converter from being damaged, the following precautions must be observed:

- Use the fuel suitable for your vehicle. The Company assumes no responsibility for the mistake of filling a wrong type of fuel. If you fill a wrong type of fuel carelessly, contact Our Service Dealer for service immediately. Do not start the engine.
- If the vehicle is difficult to start or driving performance degrades during driving, please drive the vehicle to a nearby Our Service Dealer for service.
- Do not drive under extremely low fuel level. The engine may be unable to start during driving under fuel exhaustion.
- Do not start the vehicle by pushing or trailing it.
- Do not shut down the engine during driving.

DPF (Diesel Particulate Filter)

Note: *It applies to models equipped with diesel engine.*

The main function of DPF is to collect particles in vehicle exhaust, and to remove particles collected in DPF through active and triggered regeneration in a certain period to achieve the function of recovering DPF to collect particles. Active regeneration refers to the function of the engine to automatically start and recover DPF to collect particles in vehicle exhaust according to actual working conditions. Triggered regeneration refers to the regeneration that the current working conditions of the engine cannot meet the active regeneration conditions and requires human intervention.

Switching regeneration of DPF one-key regeneration

Instrument alarm prompt

Level 1 alarm prompt: "Please keep the vehicle speed at more than 60 km/h when safe and legal, or stop the vehicle and press the DPF key in the armrest box for regeneration" is displayed on the instrument cluster for 10 seconds, the buzzer sounds three times, and the "DPF (Diesel Particulate Filter) warning light

(yellow)" on the instrument cluster  stays ON.

Level 2 alarm prompt: "Please stop the vehicle and press the DPF key in the armrest box for regeneration in situ while ensuring surrounding safety" is displayed on the instrument cluster for 10 seconds, the buzzer sounds three times at an

Starting and Driving

interval of 10 seconds, and the "DPF (Diesel Particulate Filter) warning light (yellow)" on the instrument cluster flashes at 1 Hz.

During regeneration, "xx% of DPF regeneration has been completed, please wait patiently" is continuously displayed on the instrument cluster, and the "DPF (Diesel Particulate Filter) warning light (yellow)" on the instrument cluster flashes at 0.5 Hz.

After regeneration, "Regeneration in situ is completed and normal driving is available" is displayed on the instrument cluster for 10 seconds, the buzzer sounds once, and the "DPF (Diesel Particulate Filter) warning light (yellow)" on the instrument cluster turns off.

If the regeneration cannot be accepted, "DPF cannot perform regeneration due to xx (Display the cause code), ** (Display the recommended operations to be performed by the user)" is displayed on the instrument cluster for 10 seconds, the buzzer sounds once, and the "DPF (Diesel Particulate Filter) warning light (yellow)" on the instrument cluster turns off. When DPF cannot perform regeneration due to xx (Display the cause code), the cause code and its corresponding cause are as follows:

- 1: Engine not started
- 2: Coolant failed to reach the proper temperature range
- 3: Oil failed to reach the proper temperature range
- 4: Failed to reach the proper ambient pressure
- 5: Fuel failed to reach the proper temperature range
- 6: Insufficient battery voltage
- 7: Clutch not released
- 8: Not in N gear

- 9: The vehicle speed is not equal to zero
- 10: Engine speed failed to reach the proper range
- 11: Engine torque failed to reach the proper range
- 12: Accelerator pedal not released
- 13: Upstream temperature of DPF failed to reach the proper range 1
- 14: Upstream temperature of DPF failed to reach the proper range 2
- 15: Upstream temperature of DOC (Diesel Oxidation Catalyst) failed to reach the proper range 1
- 16: Upstream temperature of DOC (Diesel Oxidation Catalyst) failed to reach the proper range 2
- 17: DPF particulates below the regeneration limit
- 18: DPF-related faults
- 19: Engine-related faults
- 20: Exceeded the maximum allowable regeneration time
- 21: Upstream temperatures of DOC (Diesel Oxidation Catalyst) and DPF failed to reach the target values within the allowable time range 1
- 22: Upstream temperatures of DOC (Diesel Oxidation Catalyst) and DPF failed to reach the target values within the allowable time range 2
- 23: Exceeded the maximum allowable temperature 1 of upstream DPF
- 24: Exceeded the maximum allowable temperature 2 of upstream DPF
- 25: Exceeded the maximum allowable temperature 1 of upstream DOC (Diesel Oxidation Catalyst)
- 26: Exceeded the maximum allowable temperature 2 of upstream DOC (Diesel Oxidation Catalyst)
- 27: Service station regeneration not activated
- 28: Brake pedal not released

Switching regeneration steps

- 1 Stop the vehicle, shift to N gear for models with the manual transmission (P gear for models with the automatic

Starting and Driving

transmission), apply the parking brake (or activate the parking brake), and turn off the ignition key (or ignition switch) for 2 minutes;

- 2 Start the vehicle;
- 3 Open the central armrest box, and then the one-touch regeneration switch panel. Press the one-touch regeneration switch and hold it for 2 seconds, then DPF regeneration will begin.

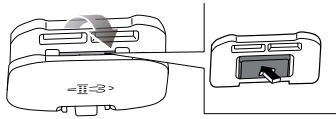

Note: If the engine speed rises to 2,000 rpm, the regeneration trigger is successful; otherwise it is unsuccessful. Turn off the ignition key (or ignition switch) and wait for 2 minutes, and then operate again according to the above steps. Unless driving is necessary after regeneration starts, stay in N gear (models with the manual transmission) / P gear (models with the automatic transmission), and keep the vehicle stopped. Do not perform other operations (e.g. depressing the brake pedal, clutch pedal, accelerator pedal, etc.) until the engine speed returns to idle speed.

Caution

DPF regeneration temperature is very high, please park the vehicle in an open and ventilated place, and make sure there are no inflammables (e.g. hay, oil, etc.) around when using. If it cannot be regenerated successfully for several times, please go to Our Service Dealer for processing.

2

Conditions of regeneration

- The DPF is overloaded, and the particle value exceeds the set value (the instrument panel has level 1 and level 2 alarms).
- The water temperature is above 40 degrees Celsius.
- No DPF-related function error.
- The vehicle speed is 0, and the gear is N for models with the manual transmission and P for models with the automatic transmission.

Possible causes of regeneration failure

- The clutch pedal is depressed.
- The gear is not in N for models with the manual transmission and not in P for models with the automatic transmission.
- The vehicle is not stopped (the vehicle speed is not zero).
- The accelerator pedal is depressed.
- The brake pedal is depressed.
- The engine conditions are not satisfied (for example, the water temperature is too low and the exhaust temperature is too high).
- The engine has DPF-related fault(s).

Starting and Driving

- The regeneration steps were not followed.

Regeneration steps for high load driving

- 1 Carry out high-load conditions cycles, such as high-speed driving (vehicle speed is maintained at 60km/h and above);
- 2 Drive the vehicle for about 20 minutes.

Special driving conditions

Under the following circumstances, the vehicle has almost no triggered regeneration, and the efficiency of active regeneration is generally low or even zero, requiring the attention of the driver to try the best to avoid:

- Repeatedly start and stop the vehicle.
- Operate the vehicle at a low speed and a low load for a long time.
- The vehicle idles for a long time in stationary state.

Caution

The cumulative amount of DPF carbon deposition will increase after a long time idling. If your vehicle needs to keep operating at idle speed for a long time, when the active regeneration function of the vehicle is enabled, please depress the accelerator actively to make the engine speed reach 2,000 ~ 2,500 rpm to assist regeneration.

Fuel

Fuel filler cap

Before opening the fuel filler cap, please turn on the fuel filler flap opening switch (1)  on the driver's door first, and then open the fuel filler flap from the vehicle interior.

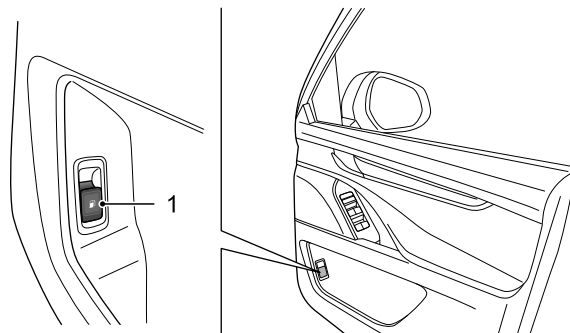

Starting and Driving

Rotate the fuel filler cap counterclockwise to remove it, and secure it on the bracket of the filler flap, then refuel. After refueling, 3 clicks need to be heard when tightening the fuel filler cap clockwise, which indicates that the fuel filler cap has been tightened in place, then close the fuel filler flap.

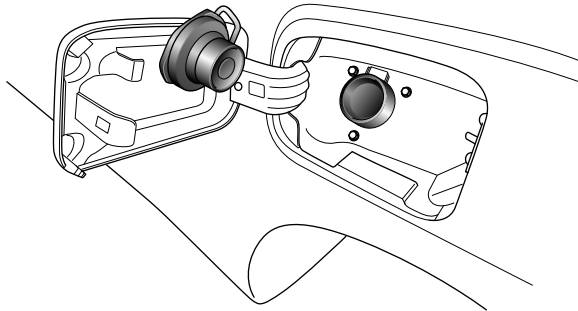

Refueling

! It is prohibited to mix fuel with engine oil, kerosene, paraffin, water or other liquids for use, which may damage the fuel system.

Do not fill so much fuel that the fuel can be seen in the filling port or overflows, leading to a fuel contact risk for you and other persons.

Select the fuel to be added according to the label on the fuel filler port of vehicle's tank. Please refer to "Main Engine Parameters" in the General Technical Parameters section.

Caution

- It is recommended to use high-quality fuel free of additive or other engine cleaner.
- If you fill a wrong type of fuel by accident, contact our Service Dealer for service immediately. Do not start the engine at this time. If the engine is started with a wrong type of fuel filled, the fuel system components will be damaged severely. This kind of damage is not covered by warranty.



In order to prevent fuel from overflowing, please stop refueling when the fuel filler nozzle is automatically closed. If you continue refueling at this time, the fuel tank will be overfilled and the fuel will overflow when the outdoor temperature is high or the vehicle makes a turn.

Starting and Driving

Gasoline detergent

Note: It applies to vehicles equipped with gasoline engine.

The gasoline detergent, with the functions of improving the vehicle driveability, cleaning the gasoline, fuel injector, air intake valve, combustion chamber and fuel pipeline system automatically and avoiding the carbon deposit in the engine, plays an important auxiliary role in protecting the good working condition of the engine, improving the combustion efficiency, lowering the fuel consumption as well as extending the service life of the engine.

Note: Our Service Dealer can provide certified gasoline detergent. For more detailed information about gasoline detergent usage, please consult our Service Dealer.

Caution
<ul style="list-style-type: none">• Please use the gasoline detergent recommended by our Service Dealer.• The gasoline shall be free of any additive unauthorized by the Company.

Save fuel

Fuel consumption is mainly influenced by three factors:

- Vehicle maintenance mode
 - Please go to our Service Dealer for regular maintenance of the vehicle in accordance with the provisions in the "Warranty and Maintenance Manual".
 - Check the tire pressure periodically.
- Vehicle driving mode
 - Avoid high-speed driving at low gears (the gear shall be shifted), otherwise the vehicle will consume more fuel.
 - Frequent cold start and/or short-distance driving consumes a lot of fuel.
 - The vehicle will consume a lot of fuel when driving on a blocked or winding road or driving uphill.
 - Pre-consider possible risks to avoid emergency brake.
 - Make sure the parking brake handle is released completely during driving.
- Vehicle Load
 - The heavier the load is, the higher the fuel consumption is. Do not add unnecessary load.

Starting and Driving



The following driving precautions will help you to save fuel and protect the environment.

- Ensure the tire pressures are correct.
- Avoid accelerating immediately after starting, and avoid depressing the accelerator pedal all the way down.
- The driving time at low gears shall not be excessively long.
- Try to use the top gear when the engine runs steadily.
- Pre-consider possible barriers, crossroads, sharp bends or traffic lights, and adjust vehicle speed correspondingly in advance.
- If it is predicted that the traffic may be blocked for a long time or it is required to wait for a long time, please shut down the engine if allowed by safety conditions.

Precautions for cold weather



It is prohibited to use lamp oil (kerosene) as the additive.

In order to reduce possible problems which may occur in cold weather, please consider the following suggestions:

- Please use the fuel conforming to winter requirements.
- Park the vehicle in an area which can maintain the fuel temperature above -9°C .
- Fill the fuel tank after driving every day. This practice will reduce the possibility of fuel condensation and accordingly reduce the influence of water generated due to temperature rise after condensation on oil quality.
- Replace the element of fuel filter according to the recommended time interval.
- Maintain the battery power in normal state.

Caution

Additive may degrade the lubricating property of fuel, accelerating wear and damage of engine and fuel injector.

Starting and Driving

Manual Transmission

Gear Shift

During the gear shift, depress the clutch pedal completely, and then move the shift lever. After the gear shift, release the clutch pedal slowly.

The shift lever knob is marked with all gears.

6-speed Manual Transmission

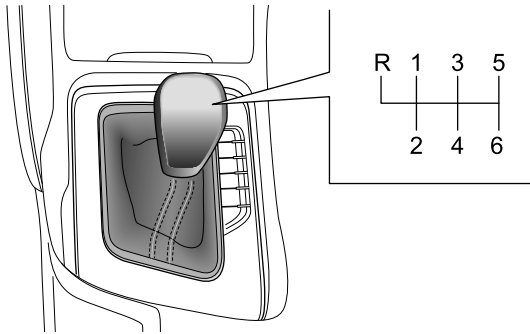

6th gear: Completely push the shift lever to the right side by the force greater than the spring stress, and then push it to the bottom. When shifting to the 5th gear, do not apply a lateral pressure towards left, otherwise the gear may be shifted to the 3rd gear by accident. Then the engine will overspeed as a result.

Note: Do not shift to R gear before the vehicle stops. The shift lever cannot be directly shifted from the 1st to R gear and must be shifted to N first.

R gear: Place the shift lever in N position, press the button in the front end of the shift lever, move it fully to the left, then push it upward.

Caution

Before shifting into/out of R gear, the vehicle must come to a full stop. Depress the clutch pedal, and shift to R gear after a while. Upshift must be done in sequence. It is prohibited to start off with the 2nd gear. Transmission shall not be shifted to N gear for coast down, it is prohibited to shift to N gear, especially when the vehicle drives downhill, so as to prevent the burning damage of the synchronizer and various types of bearings.

6AT Automatic Transmission

Operation

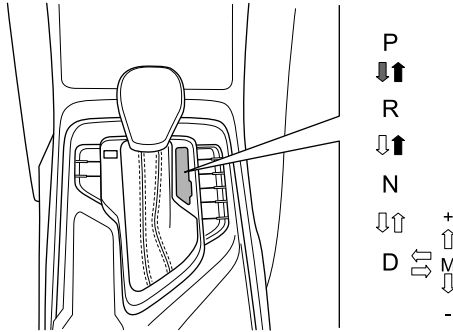

⇒ When the vehicle is started or the ignition switch is in "ON" position, depress (and hold) the brake pedal, and press the lock release button in the upper front of shift lever during gear shift.

➡ Press the lock release button in the upper front of shift lever when moving the lever.

⇔ The shift lever can also be moved without pressing the lock release button.

6AT automatic transmission consists of 6 drive gears and 1 reverse gear. Each gear can be automatically engaged according to the position of shift lever.

To realize smooth driving, depress the brake pedal when shifting from N (neutral gear) to Drive or Reverse gear.

! Check for the condition of pedestrians near the vehicle, especially children, before shifting to D (drive) gear or R (reverse) gear.

Make sure the shift lever is in P (park) position before leaving the driver seat; then set the parking brake and shut down the engine.

Caution

To avoid damages to transmission, do not accelerate the engine under the condition of stepping on the brake pedal and engaging R (reverse) gear or other Drive gears. When parking uphill, do not secure the vehicle with engine power but with the brake or parking brake. When the engine rotating at a speed higher than idle speed, do not shift from N (neutral) gear or P (park) gear to D (drive) or R (reverse) gear.

Starting and Driving

Gears

P (Park)

 **Engaging P (park) gear during vehicle running will cause transmission damage. Do not use P (park) gear to replace the parking brake. Make sure the shift lever is at P (park) gear and the parking brake is completely set.**

Fully stop the vehicle before shifting to P (park) position. The transmission output gear is locked in this position to prevent driving wheel from moving.

R (Reverse)

 **Fully stop the vehicle before shifting to/out of R (reverse) gear; shifting to R gear during vehicle running will cause transmission damage.**

R gear is used for reversing a vehicle.

N (Neutral)

Neither the vehicle nor the transmission is locked. The vehicle will slide down freely from a slightly inclined slope unless the brake pedal is depressed or the parking brake is set.

Note: Don't engage N (Neutral) while driving.

D (Drive)

It is a common Drive gear position. The transmission will automatically shift among 6 gears in sequence to provide the most fuel-efficient and the maximum power.

During overtaking or climbing up a hill, fully depress the accelerator pedal, the transmission will automatically downshift to provide extra power.

Position M (Manual)

No matter the vehicle is idling or running, you can choose the manual mode by switching the shift lever from D (Drive) gear to M (Manual) position. To return to D (Drive) gear, push the shift lever back to D (Drive) position.

Compared to manual transmission, the 6AT automatic transmission allows gear shift to be done with accelerator pedal depressed under manual mode.

(+): Push up the shift lever once to a higher gear.

(-): Pull down the shift lever once to a lower gear.

Note: It does not need to press the lock release button in the front of shift lever and the lever can automatically restore. M represents the position, and there is no sign on the panel.

Manually release P gear lock

In case of a dead battery or transmission computer failure, the vehicle will be unable to recognize the signal from the brake pedal, and it is required to manually release the P gear lock. Push the vehicle to a safe place.

Pry up the small cap on the gear shift panel as shown in the figure, insert the mechanical key portion and press (and hold) the "P gear unlock button" under the cap, while holding the shift lever and pressing the lock button on the lever to pull back the lever from P gear to N gear. Then recover all removed parts, and engage in P gear after parking.

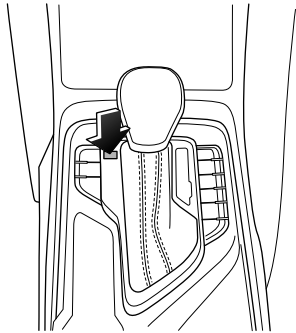

8AT Automatic Transmission

Gear

P (Park Gear)

⚠ Engaging P (park) gear during vehicle running will cause transmission damage. Do not use P (park) gear to replace the parking brake. Make sure the shift lever is at P (park) gear and the parking brake is completely set. The vehicle must be stopped completely before adjusting to P (parking) position. The transmission output gear is locked in this position to prevent driving wheel from moving.

P gear is used to assist in parking and starting the engine.

R (Reverse gear)

⚠ Fully stop the vehicle before shifting to/out of R (reverse) gear; shifting to R gear during vehicle running will cause transmission damage.

R gear is used to reverse.

N (Neutral gear)

⚠ When stopping temporarily in N gear, apply the parking brake or depress the brake pedal, otherwise there is a risk of slipping or accident.

Do not shift to N gear while driving.

Starting and Driving

N gear is powerless and the transmission system does not transfer any power.

D (Drive gear)

D gear is generally a forward gear. When driving normally, it is recommended to use D gear. The transmission can adaptively adjust the gear ratio for optimal economy.

M (Manual)

During acceleration for overtaking or driving uphill and downhill, it is recommended to use M gear.

Gear shift operation (Type 1)

! Situation of the mass surrounding the vehicle especially children must be checked before shifting to D (drive) or R (reverse) gear. Make sure that the shift lever is in P (park) position, apply the parking brake and shut down the engine before leaving the driver seat.

To avoid damages to the transmission, do not accelerate the engine while depressing the brake pedal and shifting to R (reverse) or D (drive) gear. When parking on a slope, do not secure the vehicle with engine power. Please use the parking brake. When the engine rotates at a speed higher than 2,500 rpm, do not shift from N (neutral) or P (park) gear to D (drive) or R (reverse) gear.

After the engine is started, normal gear shift operations can be performed.

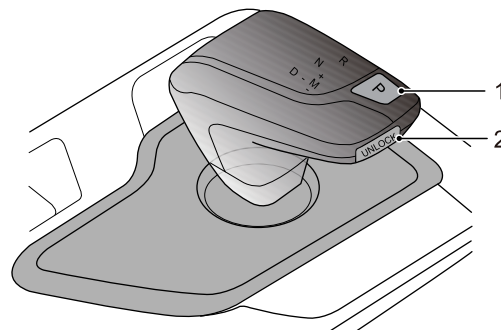

1 P gear button

2 Unlock button

Shift to P gear

When the vehicle is stationary, press the P gear button (1) to shift to P (park) gear.

Starting and Driving

Shift to R, N and D gear

- In P/D gear

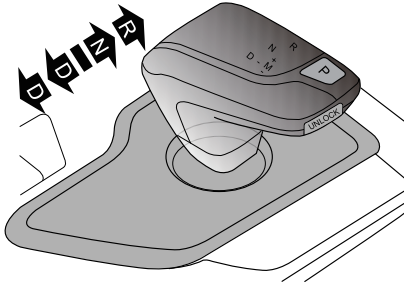

- In N gear

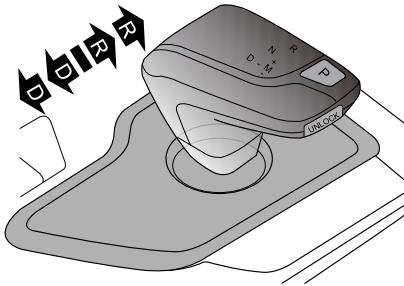

- In R gear

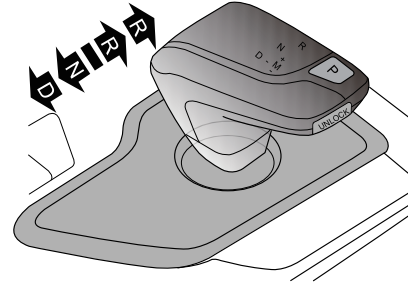

2

Push or pull the shift lever briefly in the desired direction (two positions forward and backward). When the shift lever is released, it will return to the neutral position.

When shifting from P (park) gear to R (reverse) gear, it is necessary to depress the brake pedal and press the unlock button (2); when shifting to D (drive) gear, it is necessary to depress the brake pedal.

The engaged gear will be displayed in the shift lever handle and instrument information center.

Starting and Driving

M gear (Manual)

! M gear can be operated only in the automatic mode D gear; do not try to move the shift lever to the right in other gears.

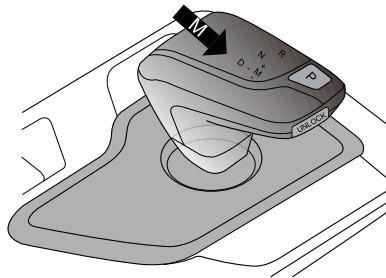

In the automatic mode D gear, move the shift lever to the right to switch to M gear and select the manual mode, and push or pull the shift lever forward or backward to change the gear. To return to D (Drive) gear, move the shift lever to the left D gear.

(+): Push the shift lever forward once to a higher gear.

(-): Pull the shift lever backward once to a lower gear.

The gear displayed in the instrument cluster will indicate the current gear of the vehicle with any of M1 ~ M8.

Note: *When the vehicle is completely stopped in M gear, press the P gear button to directly shift to P (park) gear.*

Caution

If the gear shift time selected by the driver is inappropriate in the manual mode, such as upshifting while the engine speed is too low or downshifting while the vehicle speed is too high, the transmission will not respond, and the vehicle will still be driving in the original gear. When the vehicle is running in a certain gear, the transmission will automatically downshift to the next lower gear to prevent the engine from stalling if the engine speed is lower than a certain value. When the vehicle accelerates and the engine speed continues to rise and reaches the maximum speed allowed by the gear, if there is no upshifting request at this time, the transmission will automatically upshift to the next higher gear to protect the engine.

Starting and Driving

Temporary manual mode (steering wheel paddle)

Note: It applies to models with steering wheel paddle.

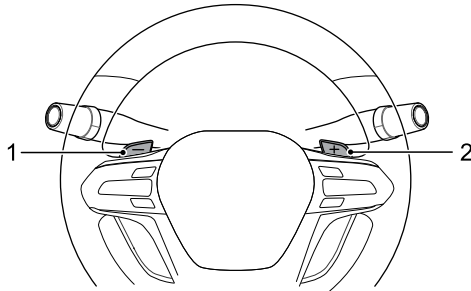

1 Downshift paddle

2 Upshift paddle

In the automatic mode D gear, operate the steering wheel shift paddle directly to enter the temporary manual mode. Upshift or downshift can be achieved by moving the paddle again. The gear displayed in the instrument cluster will indicate the current gear of the vehicle with any of D1 ~ D8.

Note: In the manual mode M gear, upshift or downshift can also be achieved by moving the paddle.

Caution

The temporary manual mode is for temporary use only, not a long-term manual state. If the shift paddle is not operated again for a period of time, the system will return to the automatic mode D gear.

Gear shift operation (Type 2)

! Situation of the mass surrounding the vehicle especially children must be checked before shifting to D (drive) or R (reverse) gear. Make sure that the shift lever is in P (park) position, apply the parking brake and shut down the engine before leaving the driver seat.

To avoid damages to the transmission, do not accelerate the engine while depressing the brake pedal and shifting to R (reverse) or D (drive) gear. When parking on a slope, do not secure the vehicle with engine power. Please use the parking brake. When the engine rotates at a speed higher than 2,500 rpm, do not shift from N (neutral) or P (park) gear to D (drive) or R (reverse) gear.

After the engine is started, normal gear shift operations can be performed.

Starting and Driving

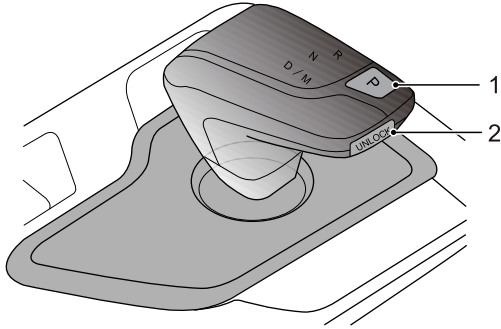

- 1 P gear button
- 2 Unlock button

Shift to P gear

When the vehicle is stationary, press the P gear button (1) to shift to P (park) gear.

Shift to R, N and D gear

- In P gear

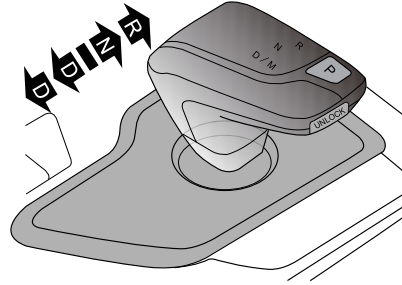

- In N gear

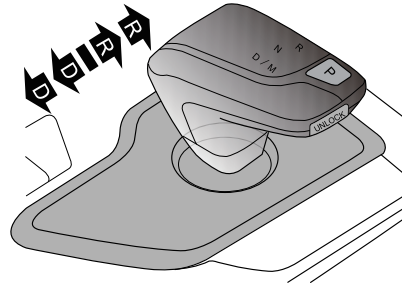

Starting and Driving

- In R gear

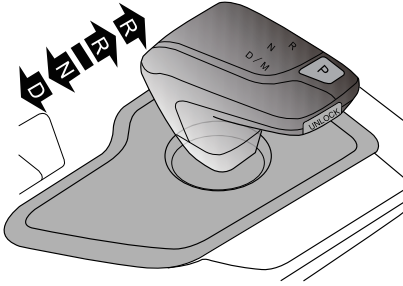

- In D gear

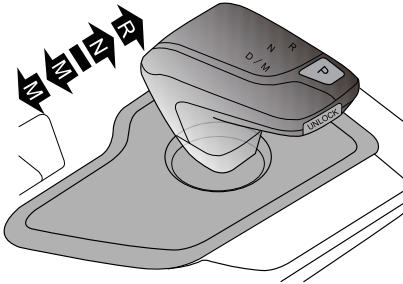

Push or pull the shift lever briefly in the desired direction (two positions forward and backward). When the shift lever is released, it will return to the neutral position.

When shifting from P (park) gear to R (reverse) gear, it is necessary to depress the brake pedal and press the unlock button (2); when shifting to D (drive) gear, it is necessary to depress the brake pedal.

The engaged gear will be displayed in the shift lever handle and instrument information center.

M gear (Manual)

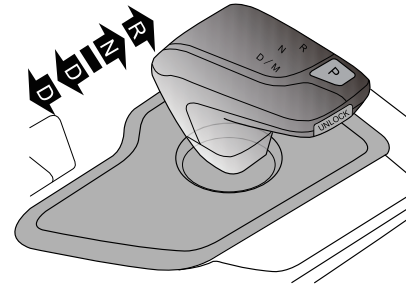

In the automatic mode D gear, move the shift lever to backward to switch to M gear and select the manual mode. To return to D (Drive) gear, move the shift lever to backward D gear.

In the manual mode M gear, upshift or downshift can also be achieved by moving the paddle. The gear displayed in the instrument cluster will indicate the current gear of the vehicle with any of M1 ~ M8.

Starting and Driving

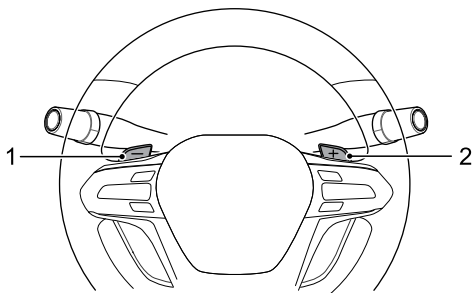

- 1 Downshift paddle
- 2 Upshift paddle

In the automatic mode D gear, operate the steering wheel shift paddle directly to enter the temporary manual mode. Upshift or downshift can be achieved by moving the paddle again. The gear displayed in the instrument cluster will indicate the current gear of the vehicle with any of D1 ~ D8.

Caution

The temporary manual mode is for temporary use only, not a long-term manual state. If the shift paddle is not operated again for a period of time, the system will return to the automatic mode D gear.

Note: *When the vehicle is completely stopped in M gear, press the P gear button to directly shift to P (park) gear.*

Caution

If the gear shift time selected by the driver is inappropriate in the manual mode, such as upshifting while the engine speed is too low or downshifting while the vehicle speed is too high, the transmission will not respond, and the vehicle will still be driving in the original gear. When the vehicle is running in a certain gear, the transmission will automatically downshift to the next lower gear to prevent the engine from stalling if the engine speed is lower than a certain value. When the vehicle accelerates and the engine speed continues to rise and reaches the maximum speed allowed by the gear, if there is no upshifting request at this time, the transmission will automatically upshift to the next higher gear to protect the engine.

Auto park function

For safety, the transmission automatically shifts to P (Park) gear when powered off while the vehicle is in other gears than P.

When the vehicle is stationary, the transmission will automatically shift to P (Park) gear to prevent slipping if the driver does not wear the seat belt and depress the brake pedal and accelerator pedal while opening the door.

Starting and Driving

Manual release of P gear lock (Towing mode)

When the vehicle fails (dead battery, transmission controller failure and shifter failure, etc.), and cannot shift out of P (Park) gear, the transmission shall be shifted manually and forcibly from P (Park) gear to N (Neutral) gear for towing. Otherwise, the transmission will be damaged.

- 1 Go to the second row of seats, grab the lower edge of the rear panel of the auxiliary fascia console with both hands (as shown), and pull it toward the rear of the vehicle to remove the rear panel of the auxiliary fascia console.

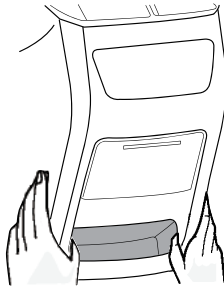

- 2 A yellow pull ring (1) and a metal bracket (2) can be seen after removal.

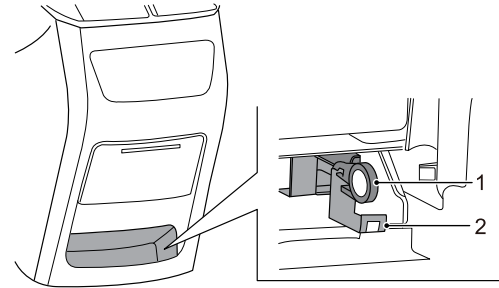

2

- 3 Pass your finger through the pull ring (1) and lift it up, then pull it backward, and stick the pull ring (1) on the metal bracket (2), so that the transmission is shifted from P (Park) gear to N (Neutral) gear.

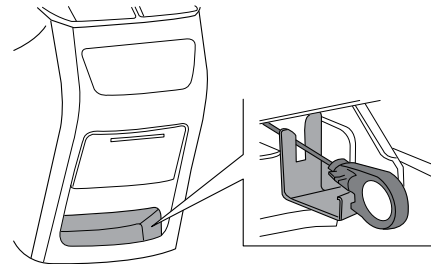

Starting and Driving

Caution

If the vehicle is powered up or started at this time, the instrument will prompt "P gear lock failure", indicating that the transmission is in the P gear unlock state. The prompt will disappear when P gear unlock cable returns to its original position.

- 4 After moving the vehicle, perform the operation steps in the reverse order of the above method immediately for recovery to avoid forced release of the transmission P gear for a long time.

Note: If the manual P gear unlock is required, a problem has occurred in the vehicle. Please contact Our Service Dealer for service. Our professional service personnel will restore P gear unlock cable and the rear panel of the auxiliary fascia console to their original position.

Electric Power Steering Device

The electric power steering gear enables you to make a turn with less force.

When the steering system fails or the engine is turned off (towed by another vehicle), the driver can still maintain the full control over steering, but greater force shall be applied to operate the steering wheel.

Four Wheel Drive System (4WD)

Part-Time 4WD System

The part-time 4WD switch is located on the floor console, and is used to select the mode of 2H (HS 2WD), 4H (HS 4WD) and 4L (LS 4WD). When a certain drive mode is selected, the corresponding prompts and indicator will be shown on the instrument cluster information center.

Precautions before Use

- When driving on a road which is dry and in good condition, if the 4H/4L mode is selected, due to the lack of inter-axle differential function, the tire wear will accelerate, the vehicle noise will increase and it is easy to cause damage to components of the powertrain system, meanwhile risks in driving may exist, so it is required to select the 2H mode, while the 4H/4L mode is prohibited.
- Large-angle turning is prohibited under 4H/4L mode, otherwise it will easily damage the components of powertrain system and cause abnormal wear of tire, even rollover accident in serious cases.
- It is prohibited to choose 4H/4L mode on the road with high adhesion (urban road, expressway, etc.). The speed must be controlled below 80 km/h under 4H mode and 30 km/h under 4L mode. If the speed exceeds 80 km/h, the system will send the audible alarm.



- If “4WD MIL (red)” on the instrument cluster illuminates, please go to our Service Dealer for inspection as soon as possible.
- When the 4H/4L mode is selected, the ESP will be turned off and the HDC, AUTO HOLD, ADAS, and EPB auto clamping/release function will be disabled (but the EPB can be clamped or released manually), corresponding indicators on the instrument panel will illuminate. When switching back to the 2H mode, the above functions will recover automatically.

2

Instructions for Switching Part-Time 4WD System

Switch on Floor Console	2H	4H	4L
Instrument Cluster Information Center	2H Mode	4H Mode	4L Mode
Drive Mode	2H	4H (HS)	4L (LS)
Driving Conditions	For the pavement road in good condition such as the urban road, expressway and etc.	For the road with low adhesion, such as snowy road, grassland, muddy road, sandy road and other roads in poor condition.	For the rough driving conditions with low speed and large torque, such as driving through the puddle, hill and shell-hole, etc.

Starting and Driving

Caution

When shifting to/out of 4L mode, stop the vehicle. For manual transmission models, fully depress the clutch pedal; for automatic transmission models, push the shift lever to N position first. It takes about 3.5 seconds to switch 4L mode. Wait patiently during the switching process until the "4L Mode" is shown on the instrument cluster information center, which indicates that the switching is completed successfully. Then release the clutch pedal or push the transmission shift lever out of N position. Starting off by fully stepping on the accelerator pedal is prohibited during switching, or the transfer case is easy to be damaged.

Switching between 2H and 4H

 **Do not shift the 2H switch to 4H switch when wheels are steering/spinning. Shift the 2H/4H switch only after the wheels stop steering or spinning.**

Place the ignition switch in "ON" mode.

Stop the vehicle stably or keep the vehicle driving in a straight line at a speed lower than 80km/h.

Note: If the vehicle speed exceeds 80km/h, when shift to 4H mode, "Please slow down" will be displayed on the instrument cluster information center, meanwhile a warning sound will be sent.

When the 2H/4H switch on the floor console is selected, "The 2H/4H mode has been selected" will be displayed on the instrument cluster information center; when the switching is completed successfully, "2H/4H Mode" will be shown on the instrument cluster information center.

Switching between 2H & 4L and 4H & 4L.

Stop your vehicle and place the ignition switch in "ON" mode.

For manual transmission models, fully depress the clutch pedal when switching; for automatic transmission models, push the shift lever to N position when switching.

Note: Switching can be made after above-mentioned conditions are met. When the 4L mode is selected, the driving modes of AUTO/NORMAL/SPORT are disabled.

When the 2H/4H/4L switch on the floor console is selected to switch the mode, if incorrect operations occur, relevant prompt information will be displayed on the instrument cluster information center. When the switching is completed successfully, the corresponding "2H/4H/4L Mode" will be shown on the instrument cluster information center.

4L mode is a special driving condition. There is a mechanical operation of gear movement in the transfer case when switching, which may cause the gear stuck. When the switching between 2H and 4H fails, please drive the vehicle forwards or backwards slowly at the speed lower than 3km/h to clear the gear stuck.

Starting and Driving

Real-Time 4WD System

The real-time 4WD switch is located on the floor console, and is used to select the mode of 2H (HS 2WD), AUTO(automatic), 4H(HS 4WD) and 4L (LS 4WD). When a certain drive mode is selected, the corresponding prompts and indicator will be shown on the instrument cluster information center.

Precautions before Use

- when driving on a road which is dry and in good condition, if the 4H/4L mode is selected, the tire wear will accelerate, the fuel efficiency will decrease while the vehicle noise will increase, and it is easy to cause damage to the powertrain system. Therefore 2H/AUTO mode is recommended under such driving condition.
- Large-angle turning is prohibited under 4H/4L mode on the road with high adhesion (urban road, expressway, etc.), otherwise it will easily damage components of powertrain system and cause abnormal wear of tire, even rollover accident in serious cases.
- It is prohibited to choose 4H and 4L mode on the road with high adhesion (urban road, expressway, etc.).
- Avoid driving the vehicle on sandy road or muddy road for a long time. If the vehicle drives on sandy road or muddy road for a long time, the overheat protection function of the system may be activated to quit out of 4WD state and switch to 2WD to protect the 4WD system.



- If “4WD MIL (red)” on the instrument cluster information center illuminates, please go to our Service Dealer for inspection as soon as possible.

Instructions for Switching Real-Time 4WD System

Switch on Floor Console	2H	AUTO	4H	4L
Instrument Cluster Information Center	2H Mode	AUTO Mode	4H Mode	4L Mode
Drive Mode	2H	AUTO	4H(4WD HS)	4L(4WD LS)
Driving Conditions	Use common drive mode on the road with high adhesion, such as expressway, urban road and other road in good condition.		For the road with low adhesion, such as snowy road, grassland, muddy road, sandy road and other roads in poor condition.	For the rough driving conditions with low speed and large torque, such as driving through the puddle, hill and shell-hole, etc.

Starting and Driving

Caution

When shifting to/out of 4L mode, stop the vehicle. For manual transmission models, fully depress the clutch pedal; for automatic transmission models, push the shift lever to N position. It takes about 3.5 seconds to switch 4L mode. Wait patiently during the switching process until the "4L Mode" is shown on the instrument cluster information center, which indicates that the switching is completed successfully. Then release the clutch pedal or push the transmission shift lever out of N position. Starting off by fully stepping on the accelerator pedal is prohibited during switching, or the transfer case is easy to be damaged.

Switching between 2H & AUTO, 4H & AUTO and 2H & 4H

Place the ignition switch in "ON" mode.

When the 2H/AUTO/4H switch on the floor console is selected, "The 2H/AUTO/4H mode has been selected" will be displayed on the instrument cluster information center; when the switching is completed successfully, "2H/AUTO/4H Mode" will be shown on the instrument cluster information center.

Switching between 2H & 4L, 4H & 4L and AUTO & 4L

Stop your vehicle and place the ignition switch in "ON" mode.

For manual transmission models, fully depress the clutch pedal when switching; for automatic transmission models, push the shift lever to N position when switching.

Note: *Switching can be made after above-mentioned conditions are met.*

When the 2H/AUTO/4H/4L switch on the floor console is selected to switch the mode, if incorrect operations occur, relevant prompt information will be displayed on the instrument cluster information center. When the switching is completed successfully, "2H/AUTO/4H/4L Mode" will be shown on the instrument cluster information center.

Note: *To prevent the false triggering of 4L mode, the 4L mode can be selected only when the 4L button is long pressed for more than 2 seconds.*

4L mode is a special driving condition. There is a mechanical operation of gear movement in the transfer case when switching, which may cause the gear stuck. When "4L Mode" cannot be switched successfully, please drive the vehicle forwards or backwards slowly at the speed lower than 3km/h.

All-Terrain Four Wheel Drive System (ATS)

ATS system optimizes the relevant control system between the powertrain, chassis and etc., controls the vehicle by operating the ATS knob, can provide help for users lack of off-road driving experience and can promote driving skills of users with rich experience in off-road driving. Users select the appropriate drive mode according to the road condition under different road conditions. ATS system can optimize all control system of the vehicle according to the drive mode selected by users to adapt the corresponding terrain. Not needing specialized knowledge, users can drive the vehicle easily and enhance effectively the trafficability, driving stability and off-road performance of the vehicle.







All-terrain four wheel drive system (ATS) switch is located on the floor console, and is used to select the AUTO (automatic), ECO (Economic), SNOW, MUD, SAND, and ROCK to switch. When a certain drive mode is selected, the corresponding prompts and indicator will be shown on the instrument cluster information center.

Precautions before Use

- When driving on a road which is dry and in good condition, if the SAND, MUD or ROCK mode is selected, the tire wear will accelerate, and fuel efficiency will decrease. Meanwhile, it will increase vehicle noise level and cause damage to the powertrain system. Therefore, it is recommended to the appropriate drive mode according to road conditions.
- Large-angle turning is prohibited under the SAND, MUD and ROCK mode, otherwise it will easily damage the components of powertrain system and cause abnormal wear of tire, even rollover accident in serious cases.
- It is prohibited to choose the SAND, MUD and ROCK mode on the road with high adhesion (urban road, expressway, etc.).
- Avoid driving the vehicle on sandy road or muddy road for a long time. If the vehicle drives on sandy road or muddy road for a long time, the overheat protection function of the system may be activated to quit out of 4WD state and switch to 2WD to protect the powertrain system.
- If “4WD MIL (red)”  on the instrument cluster information center illuminates, please go to our Service Dealer for inspection as soon as possible.
- To prevent the vehicle from slipping when it starts off on a snowy/icy road, it shall be started off in SNOW mode with the transmission at 2nd gear, so as to improve the start-off stability and safety of the vehicle.

Starting and Driving

Instructions for Switching All-Terrain 4WD System

Switch on Floor Console	ATS Mode Indicator	Drive Mode	Driving Conditions	ESP System	Constant Speed Cruise System	Adaptive Cruise System
ECO	ECO	ECO(Economy)	For general highways and expressways (2WD state and better fuel economy).	On by default	Available	Available
AUTO		AUTO(Automatic)	For general highways and expressways (real-time 4WD state).	On by default	Available	Available
SPORT		SPORT(Sport)	For general highways and expressways (real-time 4WD state, higher upshift/downshift speed and more adequate power reserve).	On by default	Available	Available
SNOW		SNOW(Snow)	For roads with low adhesion coefficient, such as roads with snow, grass, rain or snow days and etc.	On by default	Use is prohibited	Use is prohibited
MUD		MUD(Mud)	Non-pavement roads such as: roads with mud, deep ditches, loose or rough roads and roads with deep snow.	On by default	Use is prohibited	Use is prohibited
SAND		SAND(Sand)	Loose sandy road, dry sandy road/sandy bench/sand dune/desert and roads with deep gravel.	On by default	Use is prohibited	Use is prohibited
ROCK		ROCK(Rock)	Dry river channels, Gobi, great altitude difference, steep slopes and other poor road conditions.	Off by default	Use is prohibited	Use is prohibited

Starting and Driving

Caution

When switching into or out of the ROCK mode, be sure to stop the vehicle and shift the lever to N gear position. The switching to or out of the ROCK mode may take 3 ~ 5 seconds, please wait in patient until the instrument cluster information center shows the target mode, which indicates the switching is completed. Then, shift the transmission out of the N gear position. During the switching into the ROCK mode, the transfer case will perform 4L mode switching. If you continue rotating the ATS switch at the moment, the transfer case motor may be damaged, the ATS alarm function may be triggered and the 4WD ATS MIL may be illuminated by the instrument. If the ATS alarm function is triggered by accident, you can continue rotate the ATS switch slowly to other modes but the ROCK mode to cancel the failure warning state. DO NOT slam on the accelerator pedal to start the vehicle during the switching, or the transfer case may easily be damaged.

Switching between modes of ECO, AUTO, SPORT, SNOW, MUD and SAND

Place the ignition switch in "ON" mode.

When the ECO/AUTO/SPORT/SNOW/MUD/SAND switch on the floor console is selected, "The ECO/AUTO/SPORT/SNOW/MUD/SAND mode has been selected" will be shown on the instrument cluster information center; when the switching is completed successfully,

"ECO/AUTO/SPORT/SNOW/MUD/SAND Mode" will be displayed on the instrument cluster information center.

Switching between modes of ECO/AUTO/SPORT/SNOW/MUD/SAND - ROCK

Stop your vehicle and place the ignition switch in "ON" mode.

For automatic transmission models, push the shift lever to N position when switching.

Note: *Switching can be made after above-mentioned conditions are met.*



When the ECO/AUTO/SPORT/SNOW/MUD/ROCK switch on the floor console is selected to switch the mode, if incorrect operations occur, relevant prompt information will be displayed on the instrument cluster information center. When switching is completed successfully, "ECO/AUTO/SPORT/SNOW/MUD/ROCK Mode" will be displayed on the instrument cluster information center.

ROCK is a special driving condition. There is a mechanical operation of gear movement in the transfer case when switching, which may cause the gear stuck. When "ROCK Mode" cannot be switched successfully, please drive the vehicle forwards or backwards slowly at the speed lower than 3km/h.

Electronic Differential Lock

The electronic differential lock (EDL) switch is located on the floor console, select the differential lock On/Off state with the EDL switch. The electronic differential lock can rigidly connect two half axles of rear wheels, when a rear wheel slips, the vehicle can still obtain a large driving force.

Precautions before EDL use

- The EDL is suitable for slippery roads, such as roads with grass, mud, sand, mud pits and other bad road conditions. When driving on a road which is dry and in good condition, if the EDL mode is selected, the tire wear will accelerate, the vehicle noise will increase, and it is easy to cause damage to drivetrain components, meanwhile risks in driving may exist, so it is recommended to turn off the EDL in this road condition.
- After the EDL is locked, the rear wheels are equivalent to a rigid axle connection, at this time, it is required to avoid large angle turning operation, otherwise it will easily damage the drivetrain components and cause abnormal tire wear, and even rollover accident in serious cases.
- If the "EDL Indicator Lamp (yellow)"  fails to go out or illuminate when the user operates the EDL switch, or the "EDL Indicator Lamp (red)"  illuminates, please go to our service dealer for inspection as soon as possible.

EDL use instruction

EDL Locking

When the wheel speed difference between two rear wheels is less than 10km/h, and the vehicle speed is less than 5km/h, long press the EDL switch for more than 2 seconds, and the "EDL Indicator Lamp (yellow)" on the instrument cluster illuminates, it indicates that EDL is successfully locked. When the wheel speed difference between two rear wheels is greater than 10km/h, or the vehicle speed is greater than or equal to 5km/h, long press the EDL switch for more than 2 seconds, EDL will not perform the locking operation, and "Please Slow Down to Lock EDL" will be displayed on the instrument cluster.

EDL Unlocking

When the EDL is in locked state, and the vehicle speed is less than or equal to 30km/h, long press the EDL switch for more than 2 seconds, and the "EDL Indicator Lamp (yellow)" on the instrument cluster goes out, it indicates that the EDL is successfully unlocked. When the EDL is in locked state, and the vehicle speed is greater than 30km/h (only for vehicles equipped with Real-Time 4WD System and All-Terrain Four Wheel Drive System) or 60km/h (only for vehicles equipped with Part-Time 4WD System), the EDL will be automatically unlocked, the "EDL Indicator Lamp (yellow)" on the instrument cluster goes out, it indicates that the EDL is successfully unlocked. And it will no longer be automatically locked after the vehicle speed drops.

Brake System

Service brake

Dual-pipeline hydraulic brake system



During driving, if one hydraulic pipeline fails, the



"Brake System Warning Lamp (red)" on the instrument cluster will illuminate, the failure may lead to the increase of brake pedal stroke and applied force, a longer braking distance, and even the vehicle pulling to one side. Do not try to restore the brake pedal pressure by the way of alternate press and release. If one brake pipeline has pressure failure, you must find out the cause. Please stop the vehicle immediately with care. Contact our Service Dealer for service immediately. Do not continue to drive.

If one hydraulic pipeline fails, the other hydraulic pipeline will continue working.

General status



Ensure carpet or other objects will not hinder the operation of brake pedal.

Do not take the brake pedal as the foot rest, since it may lead to brake overheat, efficiency degradation and excessive wear. Excessive worn brake pad / brake shoe will emit harsh noise or whistle, brake efficiency may be affected when the brake is applied. Please contact our Service Dealer for service as soon as possible.

If the engine stops running due to some causes, brake booster will stop working after 2 pedal operations, to achieve the expected brake effect, a larger force shall be applied on the pedal. In this case, the brake distance may be longer.

If the vehicle is not frequently in use or parked in the garage for an extended period of time, the efficiency of brake system will also be reduced. Please contact our Service Dealer for service as soon as possible.

Starting and Driving

Wet conditions



When driving in a heavy rainy day or on a muddy road, the efficiency of vehicle brake system will decline significantly. At this time, while ensuring a safe distance with other vehicles, slightly depress the brake pedal intermittently to keep the brake friction components dry. In a extremely wet weather, it may be required to repeat above operation every few kilometers.

In winter, there may be frozen ice or accumulated salt content on brake pads and brake discs. Slightly depressing the brake pedal intermittently may remove the ice and accumulated salt content.

Driving down a steep slope



Overheated brake may reduce its brake efficiency, and lead the vehicle pulling to one side.

For a steep slope which requires to apply the brake constantly, a lower gear shall be selected before driving downhill to reduce the required brake force.

ABS (Anti-lock brake system)

ABS is used to prevent wheels from locking in an emergency brake, thus to help you maintain the control on direction. No special driving skills are required.

In normal brake (the road surface has enough friction to prevent wheels from locking), ABS will not be activated.

As an important part of brake system, electronic brake-force distribution system (EBD) is used to optimize the rear wheel brake force in full load.

Important rules for emergency brake with ABS On:

- 1 Depress the clutch pedal and then completely depress the brake pedal.
- 2 Bypass the obstacle. No matter how much brake force is used, you can always maintain the control on direction.

ABS function



ABS may not be able to shorten the brake distance, depending on road surface conditions, brake distance may vary significantly. In fact, when the vehicle without ABS drives on some roads (e.g., gravel road or snowy road), the brake distance may be shorter.

When the vehicle runs at a high speed or wheels spin on slippery wet road (if there are water on the road surface, tires will fail to fully contact with road), ABS can not provide a shorter brake distance due to some physical limits.

ABS can better protect yourself and other road users from unnecessary risks. But you are still obliged to observe general safety rules and consider road, weather and traffic conditions as appropriate.

If the brake force applied exceeds the adhesion between tires and ground, which is enough to lock one or more wheels, ABS will automatically come into operation. You will hear a rapid vibration sound, and feel a slight vibration through the brake pedal.

Even when making emergency braking on a slippery road surface, be sure to depress the clutch pedal and fully depress the brake pedal. ABS is activated immediately and will continuously monitor the speed of each wheel, and change its brake pressure according to the friction available.

This can prevent the wheels from being locked to ensure the control on direction.

Precautions for driving a vehicle with ABS

- In case of emergency braking, depress the clutch pedal, meanwhile fully depress the brake pedal.
- In case of normal braking, apply force steadily on the brake pedal, and do not adopt the rapid depressing and releasing alternatively.
- Please keep in mind that steering control is still available when braking.
- Some risks can not be eliminated with ABS, such as too close with the front vehicle in driving, driving on a slippery road, and excessive pursuit of speed in driving.
- ABS can not guarantee a shorter brake distance.
- Please take it easy if a slight brake pedal vibration is heard or felt. This is a normal phenomenon when the ABS is in operation.

Starting and Driving

ESP (Electronic Stability Program)

ESP function

ESP covers the functions of ABS, EBD, TCS, VDC, EBA, RMI, HAS, AUTO HOLD, ATS and HDC.

When the ESP is enabled, ESP indicator will blink on the instrument cluster. You may hear some noise or feel the vibration of brake pedal, it is a normal phenomenon.

When the ignition switch is placed in "ON" position, ESP



indicator (yellow) will illuminate, and go off after 3 seconds. In normal driving conditions, ESP indicator keeps off, and ESP is in monitoring state. When the ESP indicator blinks, it indicates ESP is operating. You may hear some noise or feel the operation vibration of brake pedal, it is a normal phenomenon. In case of ESP failure, ESP indicator will stay on. Please take the vehicle to our Service Dealer for ESP inspection.

ESP can be turned off with ESP OFF switch , after the ESP function is turned off, the "ESP OFF Indicator Lamp



(yellow)" illuminates, and only ABS and EBD functions are available.

EBD (Electronic Brake-force Distribution)

EBD automatically detects the grip conditions between wheels and ground, distributes the brake force optimally to 4 wheels, so as to improve brake efficiency and driving stability.

TCS (Traction Control System)

TCS automatically controls the driving force at the start-off and acceleration to prevent wheels from spinning, so as to maintain the driving stability.

VDC (Vehicle Dynamics Control)

VDC is an advanced computer system, which can help you to control the vehicle driving direction in severe driving conditions. When the computer detects the deviation between the expected driving route and the actual driving direction, VDC system may selectively apply brake pressure on one or more brakes of the vehicle so as to keep the vehicle driving in the direction commanded.

EBA (Electronic Brake Assist)

In case of an emergency, the force applied by a driver on the brake pedal is usually insufficient. EBA can identify this rapid action with insufficient force on the brake pedal and automatically establishes a brake pressure up to the lock level to shorten the brake distance greatly.

RMI (Roll Movement Intervention)

RMI can identify the vehicle rollover trend as early as possible by monitoring the turning angle of steering wheel and lateral acceleration, and apply braking to one or more wheels to prevent the rollover to the greatest extent.

Starting and Driving

HAS (Hill-start Assist System)

When the vehicle drives uphill, HAS can prevent the vehicle from sliding backwards after the driver releases the brake pedal. The driver has up to 1.5s to move his foot from the brake pedal to the accelerator pedal for hill-start.

AUTO HOLD

ESP and EPB function together, to help your vehicle to park in any static conditions, without the need of depressing the brake pedal all the time. Please refer to "AUTO HOLD" in this section for its specific use.

ATS (All Terrains System)

In different drive modes, ESP responds to different road conditions by its control on different torque requests of the engine and braking force. Please refer to "Four Wheel Drive (4WD)" in this section for more information.



HDC (Hill Descent Control)

When driving on a long downhill road with a relatively great gradient (4°-26°), if the vehicle speed is within 8-35km/h, there is no need for the driver to depress the brake pedal and accelerator pedal, and the vehicle will run at a low speed automatically, so as to ensure the vehicle goes downhill steadily, at this time, the driver may correct the speed with the brake pedal and accelerator pedal.

When the vehicle speed is less than 8km/h or within 35-60km/h, HDC does not work but is in standby state.

When the vehicle speed exceeds 60km/h, HDC function will exit automatically; to re-activate it, you need to press the HDC switch  again.

When the ignition switch is placed in ON position, HDC is in off state by default, and other functions of ESP are all in standby state. When the HDC switch  is turned on, the "HDC Indicator

Lamp (green)"  on the instrument cluster illuminates, and the HDC function is in monitoring state, at this time, if HDC works, the "HDC Indicator Lamp (green)" will blink; if the "HDC Indicator Lamp (yellow)" illuminates, it indicates that HDC has a malfunction. Please take the vehicle to our Service Dealer of our company for ESP inspection. When the HDC switch  is turned off, the "HDC Indicator Lamp (green)" on the instrument cluster will go out, and the HDC function is disabled.

Instructions on ESP Off in 4WD Mode of 4WD system (only for ESP system of vehicles equipped with Part-Time 4WD System)

To ensure the vehicle's breakout capability on the rugged and slippery roads, after the 4WD system confirms the switching to 4H or 4L mode, the ESP system will be automatically turned off, and the "ESP OFF Indicator Lamp (yellow)", "HDC Indicator Lamp (yellow)", "AUTO HOLD Indicator Lamp (yellow)", "EPB Malfunction Indicator Lamp (yellow)" stay on, and the ESP

Starting and Driving

OFF switch is disabled at this time, the EPB can be manually clamped or released. When the 4WD system confirms the switching to 2H mode, the ESP system automatically resumes on, and the "ESP OFF Indicator Lamp (yellow)", "HDC Indicator Lamp (yellow)", "AUTO HOLD Indicator Lamp (yellow)", "EPB Malfunction Indicator Lamp (yellow)" go out. Please refer to "Four Wheel Drive (4WD)" for the details about the 4H or 4L mode of 4WD system.

Instructions on ESP Off in Rock Mode of 4WD system (only for ESP system of vehicles equipped with ATS)

To ensure the vehicle's breakout capability on the rugged and slippery roads, after the 4WD system confirms the switching to ROCK mode, the ESP system will be automatically turned off, and the "ESP OFF Indicator Lamp (yellow)" stays on, and the ESP OFF switch is disabled at this time. When the 4WD system confirms the switching out of the Rock mode, the ESP system automatically resumes on, and the "ESP OFF Indicator Lamp (yellow)" goes out. Please refer to "Four Wheel Drive (4WD)" in this section for the details about the ROCK mode of 4WD system.

Precautions for driving a vehicle with ESP

ESP can detect and analyze vehicle conditions and correct driving mistakes, to ensure safety by taking precautions measures. As everything has an upper limit, if a driver drives too fast exceeding the limit, all existing safety devices will be paralyzed.

EPB (Electronic Parking Brake)

The EPB switch  is located in the switch group which is in front of the central armrest and at the lower left side of the shift lever, you can control the application and release of the parking brake with the EPB switch.

Precautions before EPB Use

- With the ignition switch in ACC/ON position, the EPB is always available. To prevent excessive battery discharge, when the vehicle is not running, avoid the repeated operation of the EPB switch. When the battery power is low, the EPB system can no be applied or released.
- When starting on a slope, EPB can prevent the vehicle from inadvertent slip. EPB can be automatically released only when the traction force of the vehicle is greater than the slipping component force.
- When the normal braking operation of the vehicle fails, the emergency braking function can still brake the vehicle, refer to "Emergency Braking Function" in this section for details.
- A slight noise will be produced when the electronic parking brake is turn on or off, which is a normal phenomenon and does not have to be disturbed.
- When the vehicle power is interrupted, the parking brake can not be released in applied state, and can not be applied in release state, please connect to an external power supply.
- If the "EPB Indicator Lamp (red)"  fails to go out or illuminate when you operate the EPB switch, or the "EPB

Starting and Driving

Malfunction Indicator Lamp (yellow)  illuminates, and EPB can not be released with normal operation, please contact our Service Dealer.

- Do not apply the electronic parking brake on the road with a gradient above 30%, or the vehicle may slip. When parking on the ramp with a gradient which exceeds the limit, EPB can not fully brake the vehicle, at this time, the driver may prevent the slipping by depressing the brake pedal.

Vehicle Parking

Manual parking

- 1 When the ignition switch is in ON position or the engine is running.
- 2 The vehicle is in stationary state.
- 3 Pull up the EPB switch , the parking brake will be applied, when the "EPB Indicator Lamp (red)" on the instrument cluster illuminates, it indicates that the parking brake is applied successfully.
- 4 For vehicles equipped with manual transmission, move the shift lever in 1st gear (flat ground or uphill) or R gear (downhill) when parking. For vehicles equipped with automatic transmission, move the shift lever in P gear when parking.

- 5 When the vehicle is on a ramp, please rotate the steering wheel to ensure that the vehicle is aligned with the road edge in case of slipping.

Auto Parking

When the engine is shut down for more than 3 seconds and the vehicle is stationary for more than 1 second, the parking brake is automatically applied, and the "EPB Indicator Lamp (red)" on the instrument cluster will illuminate, thus to prevent the vehicle from inadvertent slipping.

Caution

When the vehicle power is interrupted, the released parking brake can no longer be applied, in this case, please park the vehicle on a level ground and shift into 1st gear (Manual transmission) or place the shift lever in P position (Automatic transmission) to retain the vehicle.

Disabling of Auto Parking

In some special circumstances (for example, in a car wash or when the brake disc may be covered by ice in a cold weather), if you do not need the Auto Parking function of EPB, press and hold the EPB switch in 3 seconds after the ignition switch is turned off, allow the EPB to be in release state, and observe the "EPB Indicator Lamp (red)", if the lamp illuminates, the vehicle will not enable the Auto Parking.

Starting and Driving

Starting off

Manually release the EPB.

- 1 The ignition switch is placed in ACC/ON position.
- 2 Depress the brake pedal.
- 3 Press the EPB switch  to release the parking brake, when the "EPB Indicator Lamp (red)" goes out, it indicates the parking brake is released.

Automatic Release of EPB

 **When the vehicle is stopped and the engine is running, if shifting into a gear, then it is not allowed to depress the accelerator pedal at will. Otherwise the vehicle will move immediately on its own, a risk of accident may exist.**

- 1 The ignition switch is turned on.
- 2 The driver wears the seat belt.
- 3 The transmission is shifted into a gear.
- 4 Depress the accelerator pedal. When starting off on a level or ramp road, depress the accelerator pedal, when the traction force is greater than the slipping component force, the parking brake will be automatically released, the "EPB Indicator Lamp (red)" on the instrument cluster will go out, and the vehicle starts to move.

Emergency Braking Function

Pull up and hold the EPB switch to activate the emergency braking function. At the time, the vehicle will brake all four wheels by activating the hydraulic braking system, and its braking effect is just like depressing the brake pedal with a great force. Once the EPB switch is released or the accelerator pedal is depressed with a great force, the emergency braking will be suspended.

Caution
This function applies to the situation that the normal braking operation fails.

Starting and Driving

AUTO HOLD

The AUTO HOLD switch AUTO HOLD is located in the switch group which is in front of the central armrest and at the lower left side of the shift lever, you can control the start assist system on or off with this switch.

When the vehicle often encounters the traffic lights or stop-and-go drivings, the AUTO HOLD system provides support for the driver to reduce driving fatigue. AUTO HOLD function allows the parking brake to be automatically released when the vehicle starts off, and automatically applied when the vehicle is stationary.

AUTO HOLD On

Caution

To turn on AUTO HOLD, the following conditions need to be met: the driver door is closed, the driver seat belt is fastened and the engine starts.

Press the AUTO HOLD AUTO HOLD switch, the LED in the switch illuminates, and the "AUTO HOLD Indicator Lamp (green)"



on the instrument cluster illuminates. After the vehicle is stationary, when the "AUTO HOLD Indicator Lamp (green)" on the instrument cluster blinks, AUTO HOLD is operative, and the driver may release the brake pedal. When AUTO HOLD is operative, firstly it will apply the ESP pressure retaining parking, if the vehicle is still in stationary state after 10 minutes, ESP will

request the EPB clamping parking. The "AUTO HOLD Indicator Lamp (green)" goes out, and the "EPB Indicator Lamp (red)" illuminates.

When AUTO HOLD is operative, opening a door or unfastening a seat belt will activate the EPB, the "AUTO HOLD Indicator Lamp (green)" goes out, and the "EPB Indicator Lamp (red)" illuminates.

If you shift into a gear and depress the accelerator pedal as usual, the parking brake will be automatically released, and the vehicle starts off. The "AUTO HOLD Indicator Lamp (green)" on the instrument cluster stays on, and AUTO HOLD is in standby state.

AUTO HOLD Off

Press the AUTO HOLD AUTO HOLD switch, the LED in the switch goes out, the "AUTO HOLD Indicator Lamp (green)" on the instrument cluster goes out, and the AUTO HOLD function is turned off.

 **Do not apply AUTO HOLD on the road with a gradient above 30%, or the vehicle may slip.**



When the "AUTO HOLD Indicator Lamp (yellow)" on the instrument cluster illuminates, it indicates that the AUTO HOLD system has a malfunction, please go to our Service Dealer for inspection as soon as possible.

Warning lamp

The warning lamps related to the brake system are: "Brake System Warning Lamp (red)", "ABS Warning Lamp (yellow)", "EBD Warning Lamp (red)", "ESP Indicator Lamp (yellow)", "ESP OFF Indicator Lamp (yellow)", "EPB Indicator Lamp (red)", "EPB Malfunction Indicator Lamp (yellow)", "AUTO HOLD Indicator Lamp (green)" and "HDC Indicator Lamp (green)", please refer to "Warning Lamps and Indicators" in the Before You Drive section.

Constant Speed Cruise Control System



Cruise control can be dangerous where you can not drive safely at a steady speed. Therefore, do not use the cruise control on winding roads or in heavy traffic. It is also dangerous to use the cruise control system while driving on a slippery road. On such roads, fast changes in tire traction can cause excessive wheel spin, and you could lose control. Do not use the cruise control on a slippery road.

Your vehicle may be equipped with the constant speed cruise control system. With the cruise control, you can maintain the vehicle speed at 40km/h or above without keeping depressing the accelerator pedal. The constant speed cruise control system does not work when the vehicle speed is less than 40km/h.

For safety's sake, when the vehicle is started, the constant speed cruise control system can only be enabled after valid brake signal is detected.

For vehicles with the traction control system or electronic stability control system, the system starts to limit wheel spinning when the constant speed cruise control system is working. In case of this situation, the cruise control will be automatically disabled.

Set cruise control

Set cruise control

! If the cruise control stays on when you do not use it, you may touch the button and accidentally enter the cruise state. Then you may get scared and lose control of the vehicle. Therefore, keep the cruise control switch "Off" until you need to use the cruise function.

The cruise control buttons are located on the steering wheel.

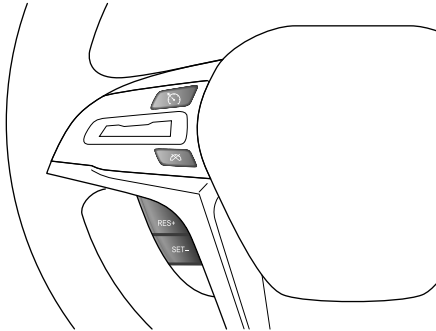

: Cruise on/off switch. Press this button to turn on/off the constant speed cruise control system. The "Constant Speed Cruise Indicator Lamp" on the instrument cluster will illuminate or go out.

: Cruise cancel switch. Press this button to cancel the cruise function without clearing the set speed in the memory.

RES+: Cruise recovery/acceleration switch. To store the set speed, press this button to recover this speed. Press this button again to accelerate (1km/h per time).

SET-: Cruise setting/deceleration switch. Press this button to set the speed. Then the cruise function will be enabled and the "Constant Speed Cruise Indicator Lamp" on the instrument cluster will turn green from white. If the cruise function is enabled at this time, press this button to lower the cruise speed (1km/h per time).

2

Set Speed

- 1 Press  to turn on the cruise control system. The "Constant Speed Cruise Indicator Lamp (white)" on the instrument cluster will illuminate.
 - 2 Accelerate to the speed required.
- Note: This speed must be higher than 40km/h.**
- 3 Press SET- button and then release, the current speed will be stored and maintained, the "Constant Speed Cruise Indicator Lamp" on the instrument cluster will turn green from white.
 - 4 Release the accelerator pedal, and then the vehicle will run at the speed set steadily. The cruise control function will be disabled when the brake is enabled.

Starting and Driving

Resume set speed

If you have set the cruise speed of constant speed cruise control system, the cruise control function will be disabled when you depress the brake pedal or press , but this set speed in the memory will not be cleared. To resume the pre-set speed, press RES+ button when the vehicle speed reaches 40km/h or above, and then the vehicle speed will be resumed to the pre-set value.

Accelerate with the cruise control system enabled

There are two method to accelerate:

- Accelerate by depressing the accelerator pedal.
- If the constant speed cruise control system has been enabled, press RES+ button and hold it until the vehicle accelerates to the desired speed, and then release it. To accelerate by minor increment, press RES+ button, and then release it. Every time this operation is done, the vehicle will speed up by about 1km/h.

Decelerate with the cruise control system enabled

If the constant speed cruise control system has been enabled:

- Press SET- button and hold it until the vehicle decelerates to the desired speed, and then release it.
- To decelerate by minor increment, press SET- button and then release it. Every time this operation is done, the vehicle will slow down by about 1km/h.

Overtaking with the cruise control system enabled



Speed up with the accelerator pedal. When you release the accelerator pedal, the vehicle will decelerate to the pre-set cruise control speed.

Applying cruise control on a ramp

The performance of the constant speed cruise control system on a ramp depends on vehicle speed, load and gradient of the ramp. When the vehicle runs uphill, it may be required to depress the accelerator pedal to maintain the vehicle speed. When the vehicle runs downhill, it may be required to brake or shift to a low gear to maintain the vehicle speed. The cruise control function will be disabled when the brake is enabled.

Terminate the cruise control

There are three ways to disable the cruise control:

- Slightly depress the brake pedal once; the "Constant Speed Cruise Indicator Lamp" on the instrument cluster will change from green to white when the cruise control is disabled.
- Press .
- Press  to turn off the constant speed cruise control system completely. The cruise control speed will not be resumed.

Clear speed memory

The cruise control set speed memory will be cleared when you press  or turn off the ignition switch.

Parking Assist System

Note: *The type of parking assist system equipped on your vehicle is subject to the actual vehicle configuration purchased.*

Reverse radar sensors

 **The parking assist system is not always reliable. It only plays the guiding role! Reverse radar sensors may be unable to detect certain types of barriers, such as fine objects like wire entanglement or rope, small objects close to the ground, tapered objects and some objects with unreflecting surfaces.**

Reverse radar sensors shall be free of dirt, ice and snow. Deposits on the surface of a reverse radar sensor will hinder the sensor's normal operation. Avoid spraying reverse radar sensors directly with high-pressure washer at a close range when washing the vehicle.

Four reverse radar sensors in the rear bumper scan the area behind the vehicle and judge whether there is any barrier. If detecting any barrier, the sensor will compute the distance between the barrier and vehicle rear end and remind the driver of the barrier through alarm sound signals. It is important to know that this system is a parking assist system only and cannot be regarded as a replacement for observation and personal judgment.

Starting and Driving

Operating state of reverse radar parking assist system:

When the R gear is selected and the vehicle speed is less than 15km/h, the system will activate the detection function.

Note: If the system keeps ringing for a long time after the gear is shifted to "R", it indicates that the system has a malfunction. Contact our Service Dealer for service as soon as possible.

During reversing:

The alarm device will start making alarm sounds when the distance between the vehicle and a barrier behind it is about 1.5m. The shorter the distance between the vehicle and barrier is, the more hurried the alarm sounds are.

When the distance between the vehicle and the barrier behind it is less than 0.4m, the alarm device will make continuous alarm sounds. At this time, if you continue reversing, the barrier cannot be identified effectively.

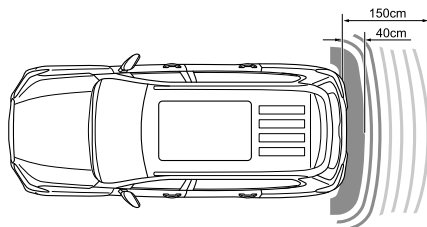

Front and rear radar sensors

⚠ The parking assist system is not always reliable. It only plays the guiding role! Reverse radar sensors may be unable to detect certain types of barriers, such as fine objects like wire entanglement or rope, small objects close to the ground, tapered objects and some objects with unreflecting surfaces.

Reverse radar sensors shall be free of dirt, ice and snow. Deposits on the surface of a reverse radar sensor will hinder the sensor's normal operation. Avoid spraying reverse radar sensors directly with high-pressure washer at a close range when washing the vehicle.

Radar sensors in the front bumper scan the area in front of the vehicle, and four radar sensors in the rear bumper scan the area behind the vehicle, and judge if there is any obstacle. If any obstacle is detected, the sensor will calculate its distance from the vehicle, and communicate this information to the driver by sounding warning chimes. It is important to know that this system is a parking assist system only and cannot be regarded as a replacement for observation and personal judgment.

Starting and Driving

Operating state of reverse radar parking assist system:

When the D gear or N gear is selected and the vehicle speed is less than 15km/h, the system will activate the detection function, at this time, the front parking radar enables the audible and visual warning function, while the rear radar only enables the azimuth display function (mute).

When the R gear is selected and the vehicle speed is less than 15km/h, both the front and rear radar will activate the detection function, at this time, both the front and rear parking radar enable the audible and visual warning function.

Note: *If the system keeps ringing for a long time after the gear is shifted to "R", it indicates that the system has a malfunction. Contact our Service Dealer for service as soon as possible.*

Note: *For vehicles without entertainment system display screen but with the 360° Around-view System, there is no visual warning function for front/rear radar.*

During reversing:

The device will begin to sound warning chimes when the rear of the vehicle is 1.5m away from the obstacle, or the front of the vehicle is 0.6m away from the obstacle, the shorter the distance with the obstacle is, the more hurried the warning chimes are.

When the distance between the vehicle and the barrier is less than 0.4m, the alarm device will make continuous alarm sounds. At this time, if you continue reversing, the barrier cannot be identified effectively.

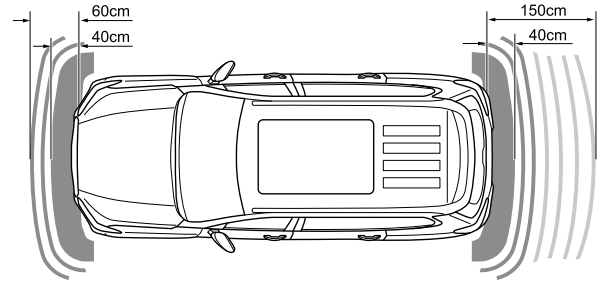

Starting and Driving

Reverse cameras

! The reverse camera parking assist system is not always reliable. It only plays the guiding role! Reverse cameras have limited view ranges and cannot detect barriers outside the view ranges.

Operating state of reverse camera parking assist system:

After shifting the gear to R, the image of entertainment system display screen will be switched to the reverse camera operating state, and the entertainment system display will show the scene image behind the vehicle for the driver's reference during reversing.

When you place the shift lever in other positions, the reverse camera parking assist system will stop operating, and the entertainment system display screen will recover to the pre-reversing state.

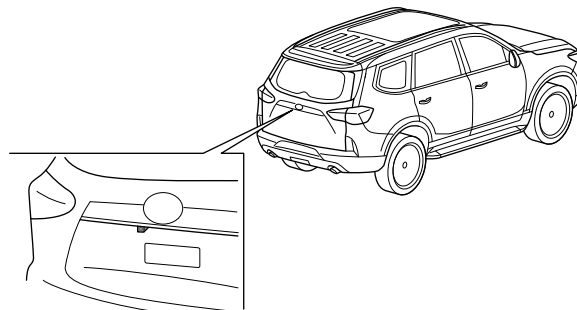

Note: When the vehicle enters the reversing state, cameras will output static reversing tracks which are displayed on the entertainment system display screen, take the horizontal plane as reference, and identify the area behind the vehicle in segments divided by red, yellow and green lines.

360° Around-view system

⚠ The parking assist system is not always reliable. It only plays the guiding role! Reverse cameras have limited view ranges and cannot detect barriers outside the view ranges.

The 360° around-view system includes 4 cameras, which are respectively installed in the front, rear, left and right of vehicle body.

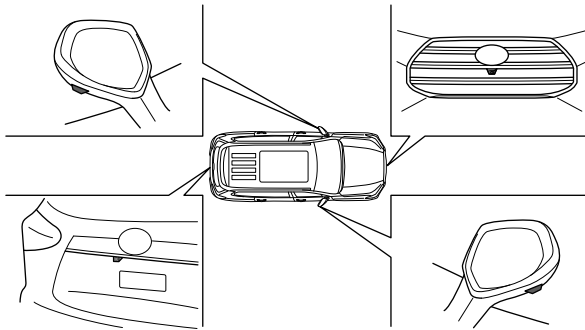

Operating state of 360° around-view system:

After shifting the gear to R, the entertainment system display screen will automatically switch to the 360° around-view interface, and then you can judge the relative position between the vehicle and barrier according to the image. Please refer to the Operating Instructions of the entertainment system mainframe.

When the vehicle speed is less than 15km/h, press the 360° around-view switch on the entertainment system display screen to turn on the 360° around-view system. Then the entertainment system display screen will switch to the 360° around-view interface of left turn, right turn or normal driving according to the current vehicle operation.



Note: Select the area to be viewed by touching the front, rear, left or right button on the entertainment system display screen.

Starting and Driving

Intelligent Semi-Automatic parking assist system

! The system is a parking assist system, which is not applicable in all cases, and can not completely replace the driver in driving and judgment, even if the system is running, the driver must be careful in driving and judgment, to avoid the risk of collision (Intervene steering wheel and brake if necessary).

Pull-in function (with D gear is selected)

- 1 Press the automatic parking switch  on the floor console to select the parking mode, the default is right-side parallel parking mode, press the  again to switch to perpendicular parking mode, after selecting the mode, it will enter the parking space search interface.



- 2 Choose left-side or right-side parking space search by turning on the turning signal lamps, search in the forward direction according to the instrument cluster information

center display, and the parking assist system searches for the parking space and determines whether the space is spacious enough; when an appropriate parking space is found, it will display the Parking Space Found interface, then the vehicle movement direction will be displayed in the instrument cluster information center interface.



- 3 Make gear shifts and control brake according to the prompts on the instrument cluster information center.

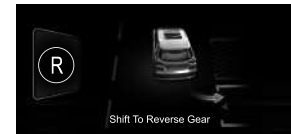

- 4 Park the vehicle, the instrument cluster information center shows "Parking Success" after the vehicle is successfully parked.

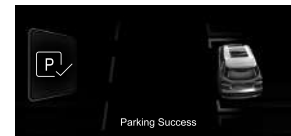

Starting and Driving

Pull-out function of parallel parking mode (with P gear is selected)

- 1 Press the automatic parking switch $P^{\text{Ⓢ}}$ on the floor console to switch to pull-out function, and switch the pull-out direction by turning on the turning signal lamps (Left pull-out is the system default).



- 2 After selecting the pull-out direction, if the system identifies by calculation that there is enough space for vehicle movement, the steering wheel will be taken over by the electronic steering system.

Steering Intervention,
Be Careful Of Ambient Environment



- 3 According to the driving direction, gear position and braking displayed in the instrument cluster information center, control the vehicle movement, to realize the semi-automatic pull-out.



Caution

During the parking, the system still maintains the radar detection warning chimes and obstacle azimuth display, to inform the driver of the obstacle information in real time to ensure the parking safety.

Intelligent Semi-Automatic Parking Assist System Exit

- Press the $P^{\text{Ⓢ}}$ button to exit the parking.
- Manually hold the steering wheel.
- When driving the vehicle to search a parking place, the vehicle speed is higher than 35km/h for more than 30 seconds.
- During the automatic steering, the vehicle speed is higher than 10km/h.
- The EPS system is invalid.
- The parking time exceeds 3 minutes.
- The steps (gear shift) during the parking exceeds 10.
- There is no obstacles and vehicle ahead when driving away from the park.

Starting and Driving

Precautions for Semi-Automatic Parking

- Before parking, please make sure there are no obstacles in the parking space, such as Stones, thin pillars, towbars or bicycles etc, as the system may not be able to detect such obstacles.
- When parking the vehicle in a parking place adjacent to the edge of the road with the intelligent semi-automatic parking assist system, the running track set by the system may go beyond the edge of the road, which results in damage to the tires or rims of the vehicle by protruding road shoulder, so pay attention to the surrounding environment, control the speed, and make manual intervention if necessary.
- Do not clean the sensor with a high pressure cleaner or a steam cleaner to avoid sensor damage. In a vehicle wash, rinse the sensor surface with a small water flow in a short time, and keep a distance of at least 10cm above.

Driver Assist System

Note: *The type of driver assist system on your vehicle depends on the actual configuration of your vehicle.*

This vehicle is equipped with the multiple functions of the driver assist system, which can provide the following functions of the active driver assist system:

- Adaptive Cruise Control (ACC)
- Forward Collision Warning (FCW)
- Autonomous Emergency Braking (AEB)
- Lane Keeping Assist (LKA)
- Lane Departure Warning (LDW)
- Traffic Sign Recognition (TSR)
- Blind Spot Detection (BSD)
- Parking Assist System
- Lane Change Assistance (LCA)
- Rear Cross Traffic Alert (RCTA)
- Door Opening Warning (DOW)

Camera of Drive Assist System

The camera of the drive assist system is used to realize the following functions:

- Adaptive Cruise Control (ACC)
- Forward Collision Warning (FCW)
- Autonomous Emergency Braking (AEB)
- Lane Keeping Assist (LKA)
- Lane Departure Warning (LDW)

Starting and Driving

- Traffic Sign Recognition (TSR)

Restrictions for Cameras

There are some restrictions for the camera unit, which limit the function of the unit.

- Limited view



Like human eyes, the view of the camera is also limited, i.e. the camera will have poor sight in storm, blizzard, fog, severe dust storm or snowy weather, etc. In these situations, reliance on the function of the camera system may be reduced or released temporarily.

When using it to scan the lane to detect the pedestrian, cyclist and other vehicles, the strong oncoming light, reflection from the lane, ice and snow on the road, dirty or unclear lane line, etc may greatly degrade the function of the camera.

Do not place, post or install any article on the outside/inside windshield before or around the camera unit, this may interfere with the related functions of the camera.

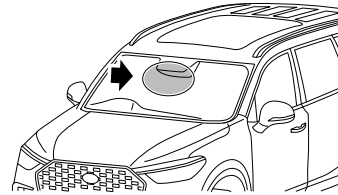

The camera unit is located at the upper side of the windshield, if the information center of the instrument cluster displays "Please Clean Windshield", "Camera System Failure", then the camera unit cannot detect other vehicles in front of the vehicle. The table below shows the example of the possible cause for the related fault displayed and the corresponding actions:

Cause	Action
The windshield before the camera unit has dirt or ice/snow.	Remove the dust, ice or snow on the windshield before the camera unit.
The view of the camera is blocked by fog, heavy rain or snow.	No remedy available. Sometimes, the recognition function of the camera unit is degraded in heavy rain or snow.
Dirt may occur between the inside windshield and the camera unit.	We suggest you drive to our Service Dealer for cleaning of the windshield in the unit cover.

Starting and Driving

Cause	Action
Direct sunlight and strong oncoming light or severe road reflection.	No remedy available. Sometimes, the recognition function of the camera is degraded in strong direct sunlight.
Damaged camera unit hardware	We suggest you drive to our Service Dealer for service.

- Damaged windshield



If the windshield before any camera unit of the windshield is cracked, scratched or damaged by stone impact, and the affected area is about 0.5x3.0mm or greater, then contact our Service Dealer for the windshield replacement and service. Failure to take any action may degrade the performance of the driver assist system using the camera unit. To avoid operation failure, insufficient or delayed operation of the driver assist system using the camera unit, please also follow the suggestions below:

- We recommend you replace the whole windshield instead of repairing the crack, scratch or damage by stone impact on the area before the camera unit.
- Before windshield replacement, please contact our Service Dealer to ensure you select and install an appropriate windshield.
- When replacing the windshield wiper, install the wiper of the same type or one approved by the Company.
- After windshield replacement, seek our Service Dealer to recalibrate the camera unit and ensure proper operation of the system functions based on the camera.

Starting and Driving

- Limited view

The camera unit has a limited view. In some cases, the camera cannot detect another vehicle, or the detection starts later than expected.

- On the curves, the ACC may respond to the vehicle in another lane, or it may not have time to respond to the vehicle in the same lane. In this case, the vehicle may collide with the front vehicle or be out of control. Particular care shall be taken for curves, and apply the brake when necessary. For driving on the curve, select an appropriate speed.

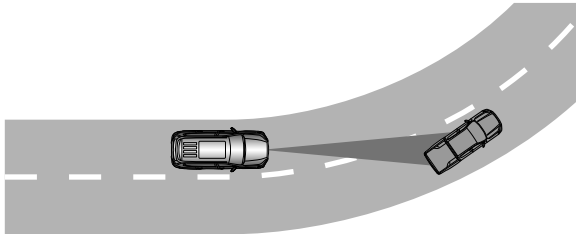

- When the vehicle from the adjacent lane drives ahead of your vehicle, if it is not within the detection range of the sensor, it cannot be detected by the sensor, this will delay the reaction of the ACC. The driver shall pay close attention to the action of the vehicle in the adjacent lane, and take active intervention when necessary.

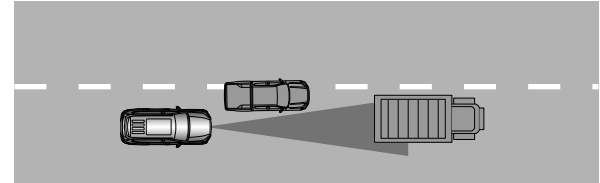

- Do not use the ACC on steep ramps. The ACC cannot detect any vehicle in the same lane on steep ramps. Normally, the driver shall control the acceleration and brake by himself on steep ramps. If the brake is applied, the ACC will be disabled. In addition, inaccurate speed control may occur when the adaptive cruise is applied on a sloped road.

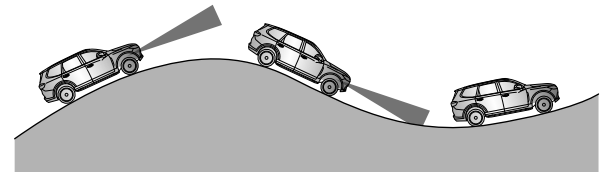

- The ACC cannot determine the accurate width of the front lane, so when the front lane is narrow, and the driver thinks that the vehicle cannot pass through it, the driver shall

Starting and Driving

disable the ACC by brake intervention immediately and control the vehicle by himself.

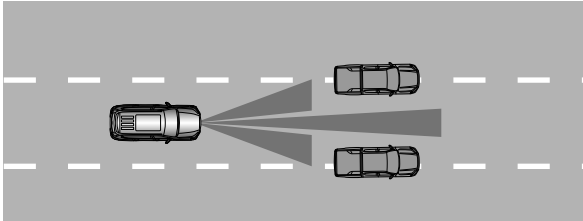

- The ACC cannot detect all kinds of vehicles on the road, especially for narrow vehicles, such as bicycle, motorbike, etc. The driver shall pay close attention to the narrow vehicle before the vehicle.

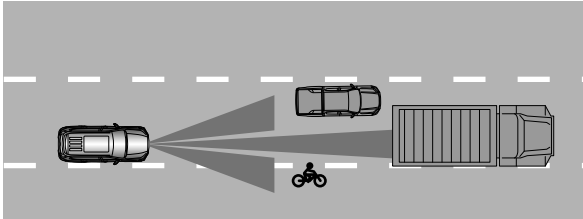

Driver assistance system millimeter-wave radar

The millimeter-wave radar of the driver assistant system is used to realize the following functions:

- Blind Spot Detection (BSD)
- Lane Change Assistance (LCA)
- Rear Cross Traffic Alert (RCTA)
- Door Opening Warning (DOW)

There are some restrictions for the millimeter-wave radar, so that the function of the radar is restricted.

- In a heavy rain, heavy snow or severe sandstorm, etc, the function may be restricted.
- When driving on sharp bends, slopes, very wide or narrow lanes, the function is restricted.

Adaptive Cruise Control (ACC)

The ACC helps the driver to maintain the same speed with the front vehicle and keep the preset interval. For long distance driving on the uncrowded motorway and long straight road, the ACC can allow you to enjoy a more comfortable and pleasant driving experience. The driver can set the desired speed and interval with the front vehicle. When the camera unit detects that the front vehicle slows down, the vehicle will automatically decelerate accordingly. When the front road is smooth again, the vehicle resumes to the set speed.

 **The driver shall always pay attention to the current traffic and intervene when the ACC does not maintain the correct speed or distance. The ACC cannot handle all traffic conditions, weather and road conditions.**

Please read all sections related to the ACC in this Manual to understand the restrictions for this function, the driver shall master these restrictions before using the function.

The driver shall always assume the ultimate responsibility for maintaining a correct distance and speed, even if the ACC is enabled.

Overview

The distance between the vehicle and the front vehicle is measured by the camera unit. The ACC controls the speed by accelerating and braking. When the ACC applies the brake, the brake will give a low noise, this is a normal situation.

The purpose of the ACC is to follow the front vehicle in the same lane at the interval set by the driver. If the camera unit cannot see any front vehicle, then the speed set/stored by the driver will be maintained. If the speed of the front vehicle exceeds the speed stored, the above may occur.

The purpose of the ACC is to control the speed steadily. When emergency braking is required, the driver shall apply the brake by himself. Also when the driver of the front vehicle suddenly depresses the brake, this involves large speed variation. Accidental braking or brake failure may occur due to restrictions for the camera unit.

The ACC is able to follow another vehicle at the speed from stationary to 150km/h.

 **The ACC is not an anti-collision system. If the system does not detect the front vehicle, then the driver shall intervene.**

The ACC does not take the brake invention for human or animal and small vehicles, such as bicycle, motorcycle, electric bicycle, including drop frame trailer, approaching, slowly moving or stationary vehicles and animals.

Starting and Driving

! Do not use the ACC for city traffic, intersection, slippery road, flooded or muddy road, overcast, rainy/snowy weather, poor visibility, twisted road or entrance/exit of the motorway.

The driver assist system is not suitable for the situations when the sunlight slants to the camera from the front; when entering/leaving the tunnel and when the main beam of the coming vehicle shines on the camera at night.

Switches of ACC

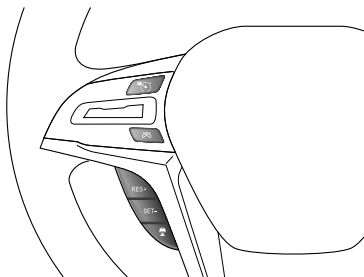

: ACC master switch, press it to turn on/off the system.

When the ACC is On:

: ACC exit switch, press it to turn off the ACC without clearing the set cruise speed.

RES+: increase the stored speed or re-activate the adaptive cruise control and resume the stored speed.

SET-: decrease the stored speed or activate the adaptive cruise control and store the current speed.

: vehicle-to-vehicle distance setting, adjust the vehicle-to-vehicle distance of the adaptive cruise control, the vehicle-to-vehicle distance will be cycled among level 1-3 by each press.

Instrument cluster display



: Vehicle-to-vehicle distance setting.

: ACC state.

: Target cruise speed.

: Ahead vehicle indicator lamp. When your car is a safe distance from the vehicle ahead of you, the ahead vehicle recognition indicator displays a solid green light; when your car is too close to the vehicle ahead, the ahead vehicle recognition indicator displays a solid yellow light.

Starting and Driving

Information center display of instrument cluster

 The ACC gives warning only to the vehicles detected by the camera, so it may not send an alarm, or there may be a certain delay for the alarm. When braking is required, apply the brake before receiving the warning.

When there is a potential risk of collision, the information center of the instrument cluster will give prompts:



The ACC can use about 40% of the braking capacity of the foot brake, if the front vehicle suddenly brakes on the motorway, the ACC cannot decelerate the vehicle to a safe speed range, then the instrument cluster will display "Press Brake Pedal", the driver shall take the brake intervention immediately.

Enable/disable ACC

When using the ACC to control speed, enable it first.

Enable ACC

- When pressing the master switch of the ACC , the instrument cluster displays:



It indicates the ACC is in STANDBY mode, ahead vehicle indicator lamp depends on whether the front vehicle is detected by the camera system.

To enable the ACC, the following requirements shall be met:

- The seat belt of the driver seat shall be properly fastened, and the driver door shall be closed.
- When the speed of the front vehicle shall achieve at least 30km/h,
- With the ACC in normal STANDBY mode, press the steering wheel button SET-, When the ACC is enabled, the instrument cluster displays:



current speed is saved to the memory as the desired speed and it is displayed on the speedometer in digital.

Note: If the information center of the instrument cluster displays *Cruise Not Available*, then the camera unit cannot detect other vehicles in front of the vehicle or the conditions for the ACC are not met.

Starting and Driving

Set ACC speed

Different ACC speed can be set. When the ACC is enabled, the cruise speed can be changed by the button on the steering wheel.

- Short press or long press the button on the steering wheel RES+ or SET- button to change the speed saved:
 - Short press the button to change the speed at +/- 5km/h: one press of the button can change +/- 5km/h.
 - Change at +/- 1km/h, hold the button, and release it when the indicator of the driver display indicates the speed required, the value pressed for the last time will be saved to the memory.

If the driver accelerates by the accelerator pedal before pressing the button on the steering wheel, then the speed saved by the button becomes the vehicle speed, provided that the driver's foot locates on the accelerator pedal at the moment the button is pressed.

Use the accelerator pedal to accelerate temporarily, for example, this will not affect the set speed during overtaking. When the accelerator pedal is released, the vehicle resumes the speed saved for the last time.

Caution

The minimum set speed of the ACC is 30km/h, i.e., this speed allows the ACC and another vehicle to decelerate till they stop, but the speed below 30km/h cannot be selected/stored.

Note: When the ACC is enabled, increase the vehicle speed by the accelerator pedal, during the period from depressing the accelerator pedal to releasing the pedal, the cruise control will be disabled, and the information center of the instrument cluster displays Accelerator Applied, Cruise Control Failure.

Interval for setting ACC

Different ACC intervals can be set.

Different intervals can be selected for the front vehicle, which are displayed as 1 - 3 horizontal lines on the information center of the instrument cluster: the more lines there, the longer the interval will be. One line represents the interval between the vehicle and the front vehicle is around 1.5s, and 3 lines indicate the interval is around 2.5s. This sign will also be displayed when the distance warning function is activated.



Note: When the ahead vehicle indicator lamp is displayed, the ACC follows the front vehicle at the interval preset.

When the ACC is activated, use the button on the steering wheel to set the vehicle-to-vehicle interval, the default value is level 3.

Starting and Driving

- When pressing the  button on the steering wheel, the vehicle-to-vehicle interval will shift within level 1 - 3 in a circular manner.

In some cases, the ACC allows the interval to change dramatically so that the vehicle can follow the front vehicle steadily and comfortably. For short distance driving at low speed, the ACC will slightly increase the interval.

Caution

In case of any unexpected situation, short interval requires the driver to respond or act within a short period of time.

Note: *The higher the speed is, the longer the distance (m) within a given interval is.*

Disable/cancel ACC

You can disable the ACC for a short time, set it to the STANDBY mode and reinitialize it later or just cancel the function.

- When pressing the  button on the steering wheel, the ACC

indicator  on the instrument cluster changes from green to white. Enable the ACC and set it to the STANDBY mode, cancel the function for a short time and set it to the STANDBY mode.

- When pressing the  button on the steering wheel, the ACC function is fully disabled, the cruise control speed will not be resumed, the ACC indication on the driver display will disappear.

Standby mode under driver intervention

Under the following situations, you can disable the ACC for a short time and set it to the STANDBY mode:

- Apply foot brake

Use the accelerator pedal to accelerate temporarily, for example, this will not affect the settings during overtaking; when the accelerator pedal is released, the vehicle resumes the speed stored for the last time.

Reactivate ACC at STANDBY mode

Press steering wheel button RES+, then, the vehicle speed is set to the speed stored lately.

Caution

When the speed is resumed by the button on the steering wheel, the vehicle accelerates significantly.

Auto STANDBY mode

The ACC is dependent on other systems, for example, ESP. If any system stops functioning, then the ACC will be disabled automatically.

In this case, the system sends an acoustic signal and the driver display will show a message. The driver shall intervene and match the speed and distance between the vehicle and the front vehicle.

The cause for auto deactivation:

Starting and Driving

- When the vehicle speed is below 5km/h, and the ACC cannot be sure whether it is a stationary vehicle or other objects in the front, for example, speed hump.
- When the vehicle speed is below 5km/h, and the front vehicle is turning, and the ACC stops to follow the vehicle.
- The driver door is open.
- The driver seat belt is unfastened.
- Low/high engine speed.
- The wheels lose grip.
- Hot brake.
- Apply the parking brake.
- ESP function is activated.
- When the ESP is OFF (i.e. press the ESP OFF switch, the indicator on the switch will illuminate, the ESP OFF indicator on the instrument pack will illuminate, and the ESP system will be turned off).
- The camera unit is affected by direct sunlight or its capacity for identifying oncoming strong light is degraded.

Target change and auto braking by ACC

At some speed, the ACC can change the target and brake.

Target Change

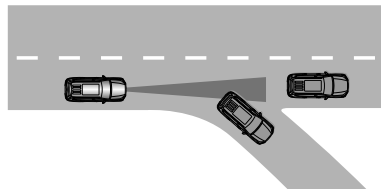

If the front target vehicle turns suddenly, the front traffic might be stationary. When the ACC follows another vehicle at a speed below about 30km/h, and the moving target vehicle becomes stationary, the ACC will brake according to the stationary vehicle.

! When the ACC follows another vehicle at a speed above about 30km/h, and the moving target vehicle becomes stationary, the ACC will ignore the stationary vehicle and select the speed stored. Then, the driver shall intervene actively and apply the brake.

Disable the ACC and set it to the STANDBY mode:

- When the vehicle speed is below 5km/h, and the ACC cannot be sure whether the target object is a stationary vehicle or other objects, for example, a speed hump.

Starting and Driving

- When the front vehicle is turning at a speed below 5km/h, the ACC stops to follow it.

Auto Braking

For short stay related to slow motion at slow traffic or traffic lights, if the stay is less than 3s, the driving resumes automatically. If the front vehicle starts to move after a long period of time, then the ACC will be set to STANDBY mode by auto braking.

Enable the ACC by one of the following methods:

- Press steering wheel button.
- Depress the accelerator pedal.

Caution
The ACC allows the vehicle to stop for at most 10min. Then the parking brake will be applied, and the ACC will be disabled. The ACC can be enabled only when the parking brake is released.

Cancel auto braking

In some cases, the auto braking stops after it is stationary, and the ACC enters into the STANDBY mode. This will cause the brake to be released, and the vehicle may start to move, so the driver shall intervene and brake manually to maintain the original state.

This may occur under the following conditions:

- Place your foot on the brake pedal.
- Apply the parking brake.

- Shift to P, N or R gear.
- The ACC is set to the STANDBY mode by the driver.

Auto Activation of Parking Brake

Under some circumstances, apply the parking brake to stop the vehicle. This may occur when the ACC keeps the vehicle stationary, and:

- The driver door is open or the driver seat belt is unfastened.
- The ACC keeps the vehicle stationary for about more than 5min.
- The brake is hot.
- The engine is OFF.

2

Starting and Driving

Restrictions for ACC





The ACC will be restricted under some situations. Always use the ACC on level roads. When driving on the steep downhill under heavy load, it is hard to keep a correct distance between your vehicle and the front vehicle by this function, in this case, you shall take particular care and get ready for braking.

Applying Cruise Control on a Ramp

The performance of cruise control system on a ramp depends on vehicle speed, load and gradient of the ramp. When the vehicle runs uphill, it may be required to depress the accelerator pedal to maintain the vehicle speed. When the vehicle runs downhill, it may be required to brake or shift to a low gear to maintain the vehicle speed.

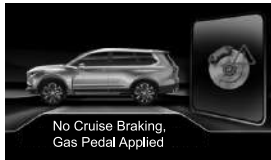
Symbol and Message of ACC

The information center of the instrument cluster will display some symbols and messages related to the ACC.

Symbol	Message	Meaning
	Please slightly depress the accelerator pedal or press the RES+ button	Restart the ACC at the STANDBY mode.
	Accelerator Applied, Cruise Control Braking Failure	If you depress the accelerator pedal when the ACC is enabled, the function will fail automatically.
	Press Brake Pedal	The driver shall intervene.
	Camera System Failure	The system is in abnormal state. Please contact our Service Dealer for service.
	Cruise Unavailable	The system is not available for the moment.

FCW and AEB

The FCW alerts the driver of the front pedestrian, bicycle or vehicle by visual and acoustic signals. If the driver fails to take actions within a rational time, the system will trigger the AEB automatically.

The FCW can prevent collision or decrease collision speed, providing aid when there is a risk of collision with the pedestrian, bicyclist or other vehicles.

The AEB is an auxiliary function which helps the driver to avoid collision at traffic jams, for example, when an accident may occur due to change of the front traffic or distraction. When a collision is going to happen, the function can provide aid for the driver by applying the brake automatically when the driver does not apply the brake and/or when he/she does not avoid an obstacle due to slow action.

The AEB provides short, quick braking and it stops the vehicle under normal situations, exactly behind the front vehicle. For most of the drivers, this is not a normal driving style, so they may feel uneasy.

The AEB is enabled only when the driver applies the brake in advance, therefore, it cannot help the driver in all cases.

To avoid unnecessary intervention, the design of the AEB requires late initiation.

Normally, the driver or passenger notices the AEB only when a collision is coming.

The AEB can decrease the vehicle speed to 40km/h at most, this avoids collisions with the front vehicle or bicycle.

If the speed difference is higher than 40km/h, then the AEB cannot avoid the collision automatically. To completely avoid the collision in this situation, the driver shall apply the brake in advance.

 **The AEB shall not be the reason for the driver to change the driving style at will. If the driver totally relies on the AEB, a collision will happen sooner or later.**

2

Enable FCW and AEB

Set in the vehicle state mode in entertainment system: Vehicle State Mode→Vehicle Control→Driving Assist; Options: OFF/Alarm/Alarm + Auto braking.

The FCW and AEB perform three procedures in the sequence below:

1 Collision Warning

First warn the driver of a possible collision. The FCW can detect the pedestrian, bicyclist, stationary vehicle or vehicle moving in the same direction before the driver's vehicle. When there is a risk of collision with the pedestrian, bicyclist or other vehicles, the vehicle will alert the driver via the



blinking "FCW/AEB Warning Lamp (yellow)"
acoustic signal and mild tactile warning in the form of

Starting and Driving

cadence braking. For low speed, emergency braking or acceleration, no tactile warning is provided.

2 Brake Support

If the risk of collision has already escalated, then the auxiliary brake will be enabled. If the system thinks the braking force is not sufficient to avoid the collision, it will strengthen the braking force of the driver by the auxiliary brake.

3 Auto Braking

The auto braking is enabled at the final step. In this case, if the driver still does not take any anti-collision action, and a collision is going to happen, then the auto braking will be triggered. This happens whether the driver applies the brake or not. Apply the maximum braking force to reduce collision speed, or apply a limited braking force sufficient to avoid a collision. When the AEB successfully avoids a collision with the static object, the vehicle will come into a standstill to expect for the driver's action. In the event that the slow speed of the front vehicle causes the vehicle to stop, the vehicle speed will be decreased to the same level as the front vehicle. The driver can stop the brake intervention by depressing the accelerator pedal at any time.

Caution

When AEB applies the brake, the brake lamps illuminate.

When the AEB is enabled and the brake is applied, the



"FCW/AEB Warning Lamp (red)" on the instrument cluster will illuminate, and it will send an acoustic alarm to indicate that the function is enabled or has been initiated.



The AEB is just an auxiliary function, so it cannot work under all driving conditions, traffic, weather and road conditions. The alarm is triggered only when a collision is likely to happen. Before using the AEB, the driver shall read this section to understand the specified restrictions.

When the vehicle speed is above 80km/h, the alarm and brake intervention function for the pedestrian and bicyclist will be disabled. The auto braking function of the AEB can prevent collision or decrease collision speed. To ensure a full braking performance, the driver shall always depress the brake pedal, even for auto braking.

The AEB will not enable the auto braking option under heavy acceleration. The driver shall always keep a correct distance and speed, and never wait the system to send a collision warning or the AEB takes an intervention.

Sensitivity Setting of FCW

With the FCW enabled, set the sensitivity.

Starting and Driving

Set in the vehicle state mode in entertainment system: Vehicle State Mode→Vehicle Control→Driving Assist; Options: High/Medium/Low.

The sensitivity determines the warning distance of the system and controls the distance triggered by visual, acoustic and tactile warnings. If the warning is excessive or it disturbs the driver, reduce the sensitivity. This will cause the system warning to occur later and the number of the warning to be decreased.

! When there is a risk of collision, the FCW will send a warning to the driver, but this function cannot shorten the response time of the driver. To ensure the function of the AEB, high sensitivity is recommended for all drivings.

In some cases, the driver may be aware of the warning later even if high sensitivity is set, for example, when the speed changes dramatically or when the front vehicle stops suddenly.

No automatic system can work 100% under all conditions. Therefore, never driver around the pedestrian or vehicle when testing the FCW/AEB, this can cause serious damage and casualty.

Obstacle Detection by FCW and AEB

The FCW/AEB can detect obstacles such as vehicle, bicycle and pedestrian.

Vehicle

The FCW/AEB is able to detect most of the static vehicles and the vehicle moving in the same direction. To ensure the FCW/AEB can detect vehicles at night, the headlamp and tail lamp shall work properly.

Bicyclist

The best example of what kind of target will be considered as a bicyclist by the FCW/AEB is as follows:



Clear outline of the body and bicycle.

To make the best use of the system, the system function for bicyclist detection shall try to acquire accurate information about the outline of the human body and bicycle, this means the system can identify the bicycle, head, hand, shoulder, thigh, upper body and lower body by combining the standard movement of the human.

If the camera cannot capture a larger part of the bicyclist's body or bicycle, then the system is unable to detect the bicyclist. To detect the bicyclist, he/she must be an adult and the bicycle must be an adult bicycle.

Starting and Driving

! The FCW/AEB is an auxiliary function which cannot detect all bicyclists for all cases, nor can it see any vague bicyclist, for example, bicyclists who cover their body with the clothes, bicycles which load large cargoes.

The driver shall always select a proper driving style and drive at a speed that can ensure a safe distance.

Pedestrian

The best example of the system detecting the pedestrian with clear body outline is as follows:

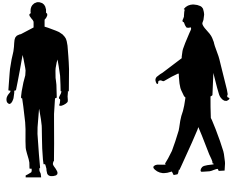

To make the best use of the system, the system function for pedestrian detection shall try to acquire accurate information about the outline of the human body, this means the system can identify the head, arm, shoulder, thigh, upper body and lower body by combining the standard movement of the human.

To detect the pedestrian, the pedestrian shall form a contrast with the background, this is subject to the clothes, background and weather. If the contrast is low, it is impossible to detect the pedestrian immediately or no pedestrian can be detected, this

means the warning and braking will be delayed or cannot be realized.

The pedestrian can also be detected by the headlamp, FCW/AEB at night.

! The FCW/AEB is an auxiliary function which cannot detect all pedestrians for all cases, the pedestrian cannot be detected under the following conditions: for example, when the pedestrian is partly covered, the clothes of the pedestrian makes his/her body difficult to identify or when the pedestrian is shorter than 80cm; when the pedestrian has a low contrast with the background, the warning and brake intervention will occur later or will never occur; and when the pedestrian carry large objects.

The driver shall always select a proper driving style and drive at a speed that can ensure a safe distance.

Restrictions for FCW and AEB

The FCW/AEB will be limited for some cases.

Ambient environment

- Low object
 - Dropping object, for example, the flag/pennant used to mark the cargo or accessories higher than the engine cover such as auxiliary lamp and bumper, will restrict the function.
- Skid

The brake distance will be prolonged on wet and slippery roads, this can degrade the anti-collision capacity of the AEB. Under these conditions, the anti-lock brake and ESP will apply the optimum braking force and maintain the stability.

- Oncoming Light

The visual warning signal on the instrument will be ignored when there is strong sunlight, reflection or when the driver wears sunglasses, or when the driver does not look straight ahead.

- View of Camera Unit

The view of the camera is limited, so it cannot detect any pedestrian, bicycle and vehicle for some cases, or the detection result will come later than expected. In dark night, the time for detecting dirty vehicles may be longer than that for other vehicles, the time for detecting the motorbike may be prolonged or no motorbike can be detected.

If the text message on the driver display indicates that the camera unit is blocked, the FCW/AEB cannot detect the pedestrian, bicycle, vehicle or road line before the vehicle. This indicates a possible degradation of the functionality of the FCW/AEB.

However, blockage of the windshield sensor does not necessarily cause an error. Therefore, the driver shall ensure the area before the windshield and camera unit is free from any obstacle.

Driver Intervention

- Reverse

When reversing your vehicle, the FCW/AEB will be disabled for the moment.

- Low Speed

The FCW/AEB will not be enabled at low speed (below 8km/h), and the system will not intervene when the driver approaches the front vehicle at a low speed, for example, when parking.

- Active Driver Action

The command of the driver always takes the priority, so the FCW/AEB will not intervene or delay the warning/intervention when the driver turns the steering wheel and accelerates, even if the collision cannot be avoided. Active and conscious driving style can delay collision warning and intervention time and minimize unnecessary warnings. When the driver actively turns off the ESP (i.e. press the ESP OFF switch, the indicator on the switch will illuminate, the ESP OFF indicator on the instrument pack will illuminate, and the ESP system will be turned off), the AEB will not intervene.

Starting and Driving

! If the camera unit fails to detect the pedestrian, bicyclist or vehicle accurately due to any traffic condition or external factor, then the system may delay or cancel the warning and brake intervention.

To detect the vehicle at night, the headlamp and tail lamp shall work and provide bright light.



Warnings for static vehicle or slow moving vehicle will be canceled due to darkness or poor visibility.

When the vehicle speed is higher than about 80km/h, the warning and brake intervention for the vehicle, pedestrian and bicyclist will be disabled.

Do not place, post or install any article on the outside/inside windshield before or around the camera unit, this may interfere with the related functions of the camera.

Symbol and Message of FCW/AEB

The information center of the instrument cluster will display some symbols and messages related to the FCW/AEB.

Symbol	Message	Meaning
	FCW System OFF	The acoustic warning and light warning of the FCW is off.
	AEB System OFF	The AEB is off.
	FCW/AEB Alarm	FCW Yellow Flash. AEB Red Illuminate.

Starting and Driving

Lane Keeping Assist (LKA)

The purpose of the LKA is to help the driver to reduce the risk of unexpected departure on the motorway or similar road for some cases.

The lane assist system has two versions:

- Lane Departure Warning (LDW): the system warns the driver by acoustic signal and light signal.
- Lane Departure Warning + Lane Keeping Assist (LDW+LKA): the system warns the driver by acoustic signal and light signal and controls the vehicle to come back to the lane.

The LDW will be enabled when the vehicle speed is within 60 ~ 150km/h and the road line is visible. The LKA will be enabled when the vehicle speed is within 75 ~ 130km/h and the road line is visible.

The function cannot be used on narrow roads, in this case, it will enter into the STANDBY mode. The function will work again when the road is sufficiently wide.

LDW interface:



LKA interface :



The action of the lane assist system depends on the version and setting:

- 1 Enabling the steering assist (LDW+LKA): when the vehicle approaches the lane line, the LKA will actively control the vehicle to return to the lane by applying a small torque to the steering wheel.
- 2 Activating warning (LDW): if the vehicle is about to go across the lane line, the system will warn the driver by acoustic signal and light signal.

When the direction indicator lamp illuminates, no steering correction information or warning from the lane assist system will be received.

! The lane assist system is just an auxiliary function, so it cannot work under all driving conditions or traffic, weather and road conditions. The driver shall always hold the ultimate responsibility for driving safety and observe the applicable laws and road regulations.

Starting and Driving

Steering Assist

The steering assist (LKA) can be enabled when the driver holds the steering wheel with both hands. The system will keep monitoring this operation. If the driver does not do so, the symbol system and LKA will use the steering message to alert the driver to control the vehicle by the information center of the instrument cluster. When the driver virtual hold or touch the steering wheel very gently, the information center of the instrument cluster may also display "Operate The Steering Wheel".



If the driver does not respond to the alert to manipulate the vehicle, an acoustic warning will be sent and the LKA will be set to the STANDBY mode. Then, the function will become unavailable as the information center of the instrument cluster displays "LKA Disabled, Take Over Steering".



No Intervention of Lane Assist

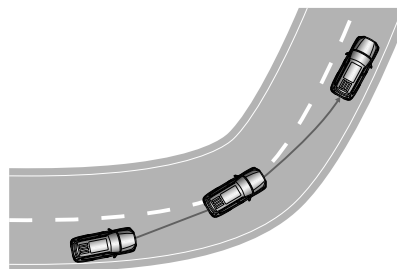

Under some circumstances, the lane assist allows the vehicle to go across the lane line without enabling the steering assist or warning. This may occur when using the direction indicator lamp or when the driver passes through a sharp turn. When the driver actively turns off the ESP (i.e. press the ESP OFF switch, the indicator on the switch will illuminate, the ESP OFF indicator on the instrument pack will illuminate, and the ESP system will be turned off), the LKA will not intervene.

Under some harsh conditions, the lane assist cannot provide right aid for the driver. For this situation, please cancel the function. Example of this condition is as follows:

- Road construction.
- Poor road surface, unclear lane line, and road conditions with interference on the lane lines.
- A sharp curb or surface line rather than a lane line.
- Extremely dynamic driving style.

Starting and Driving

- Working conditions in a tunnel.
- Winter road.
- Severe weather with reduced visibility and sloping roads.

Enable/Disable LKA

Enable LDW/LKA

Set in the vehicle state mode in entertainment system: Vehicle State Mode→Vehicle Control→Driving Assist; Options: OFF/Alarm/Alarm + Lane keeping.

Enable/Disable

The LDW can be set/canceled the function by the Personalization option of the entertainment system, or enable/disable the function by the LDW switch  on the auxiliary instrument platform.

- LDW

When the system is enabled, the display interface of the information center of the instrument cluster is as follows:



White lane markings are displayed in the instrument cluster information center interface. The LDW warning lamp



illuminates white.

When the vehicle runs at a speed above 60km/h and the system detects the left/right lane line, green lane line occurs on the display interface of the information center of the

instrument cluster, the LDW warning lamp  will illuminate in green. At this time, if the vehicle departs from the original lane line without turning on the direction indicator lamp, this warning lamp will flash in yellow with buzzer alarm.

- LKA

When the system is enabled, the display interface of the information center of the instrument cluster is as follows:



The LKA status icon  in the display of information center of instrument cluster illuminates white.

When the vehicle speed is above 75km/h, and the system detects the lane line normally, the LKA system is enabled, the LKA status icon  in the display of information

Starting and Driving

center of instrument cluster will illuminate in blue and the LDW

warning lamp  will illuminate in blue.

Sensitivity Setting of LDW

When the LDW function is enabled, its sensitivity can be set.

Set in the vehicle state mode in entertainment system:
Vehicle State Mode→Vehicle Control→Driving Assist; Options:
High/Medium/Low.

The sensitivity determines the warning distance of the system and controls the distance triggered by visual, acoustic and tactile warnings. If the warning is excessive or it disturbs the driver, reduce the sensitivity. This will cause the system warning to occur later and the number of the warning to be decreased.

Traffic Sign Recognition (TSR)

The TSR helps the driver to observe the speed sign when the vehicle passes.

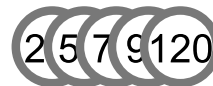

Traffic Sign Display

The TSR can use different ways to record and display the traffic sign according to the specific sign and condition.

When the TSR detects a speed limit sign with mandatory speed

limit, the sign  will be displayed as a symbol on the instrument cluster, if it is detected that the current vehicle speed is higher than that on the speed limit sign, the speed limit sign will flash and is accompanied with audible alarm, and the duration of display and flash is 3s.

Starting and Driving

Enable/disable TSR

Set in the vehicle state mode in entertainment system: Vehicle State Mode→Vehicle Control→Driving Assist, optional function: Enable/disable TSR.

Restrictions for TSR

The TSR will be limited for some cases. The example of degrading the TSR is as follows:

- Discolored sign.
- Curve sign.
- Rotating or damaged sign.
- Sign above the road.
- Partly/completely covered sign or improperly located sign.
- Signs partly/completely covered by frost, snow and/or dust.

Blind Spot Detection (BSD)

! The BSD is not always reliable. It is not the alternative but the supplementary to safe driving mode and exterior mirrors.

The BSD warning lamps are located on both exterior rearview mirrors.

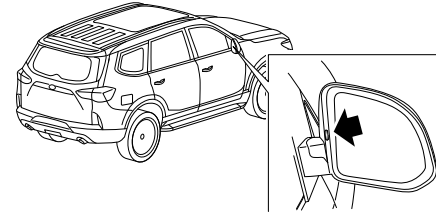

Detection areas:

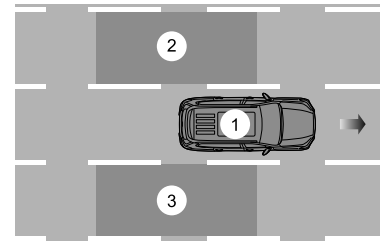

1 Main vehicle

Starting and Driving

2 Left adjacent area

3 Right adjacent area

Early warning mode

When there is a target vehicle in the left adjacent area ② or right adjacent area ③, the system will prompt the main vehicle and the warning lamp on the corresponding side will be normally on.

When there is a target vehicle overtaking the main vehicle at high speed in the left adjacent area ② or right adjacent area ③, the system will prompt the main vehicle and the warning lamp on the corresponding side will be normally on.

Emergency warning mode

When there is a target vehicle in the left adjacent area ② or right adjacent area ③, and the main vehicle is intended to change the lane (the side direction indicator lamp is on), the system will send a warning to the main vehicle and the warning lamp on the corresponding side will flash.

In the following situations, the blind spot monitoring system may not alarm:

- When the speed difference between the target vehicle and the host vehicle is too large.
- When the target vehicle is long, such as a large bus, coach, truck, etc.
- When the driving direction of the target vehicle is opposite to that of the host vehicle.

- When multiple vehicles pass the area ② or area ③ in succession, alarm may be issued only for the first vehicle passed by, and may not be issued for the subsequent vehicles.

In the following situations, the blind spot monitoring system may be interfered:

- When there is water mist or dirt on the surface of the sensor, the system may be interfered.
- Under weather conditions such as heavy rain, heavy snow and fog, the system may be interfered.
- When there are plenty of puddles on the road, the system may be interfered.
- When there are bushes or fences on both sides of the road where the vehicle runs, the system may be interfered.

Note: The BSD will be enabled when the vehicle speed is above 30km/h and below 120km/h.

Note: The system provides detection only for a limited area beside the vehicle, it cannot provide sufficient warning when a rear vehicle is approaching the vehicle.

Lane Change Assistance (LCA)

The lane change assistance system warning lights are located on both exterior mirrors. The LCA system can be switched on/off with a touch button on the entertainment system.

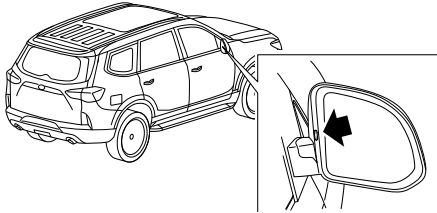

Blind spot detection

When the target vehicle enters the detection zone ①, the lane change assistance system warning light on the corresponding side will remain on.

If the direction indicator on the corresponding side will be turned on at the moment, the lane change assistance system warning light will change to flash.

Zone ① the monitoring range is the left and right areas with a width of 3 meters from the visual blind spot to 3 meters behind the vehicle.



Lane change assistance

When the target vehicle enters the detection zone ②, and rapidly approaches your vehicle, lane change could cause collision, the lane change assistance system warning light on the corresponding side will remain on.

If the direction indicator on the corresponding side will be turned on at the moment, the lane change assistance system warning light will change to flash.

Zone ② is the monitoring area of lane change auxiliary system, and the monitoring range is the left and right areas 7 ~ 70 meters behind the vehicle and 3 meters wide.

Note: The functions of blind spot detection and lane change assistance can be activated only when the vehicle speed is greater than 15 km/h.

Starting and Driving

Rear Cross Traffic Alert (RCTA)

The lane change assistance system warning lights are located on both exterior mirrors. The RCTA system can be switched on/off with a touch button on the entertainment system.

When the vehicle is backing out of the warehouse, the target vehicle enters the monitoring area (about 30 meters on both sides) and there is a collision risk, the warning light of lane change auxiliary system on the corresponding side flashes. At the same time, the alarm icon is displayed in the rear direction corresponding to the reverse image screen for 3 seconds.

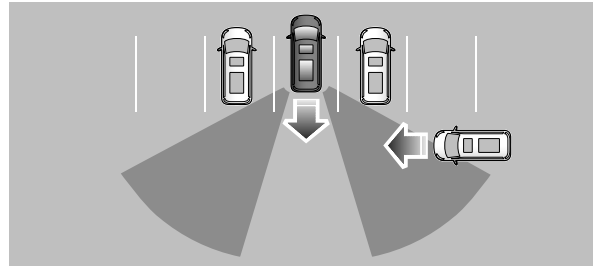
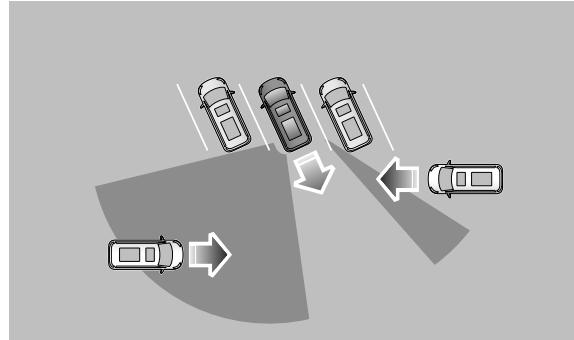

Note: The function of vehicle detection while reversing can be activated only when the speed of target vehicle is more than 10 km/h and the speed of your vehicle is less than 10 km/h.

Door Opening Warning (DOW)

! DOW only serves as an auxiliary safety system, and the perceived distance may differ from the actual one. Don't rely on the DOW solely to identify the vehicle's surrounding risks, please carefully observe the vehicle surroundings.

The DOW warning lights are located on the exterior rearview mirrors at both sides. The DOW system can be switched on/off with a touch button on the entertainment system.

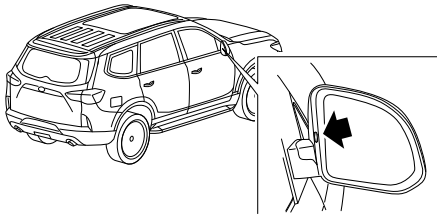

When the vehicle is pulled over, the vehicle's side rear radars will detect moving targets in the adjacent monitoring area at both sides in real time, and when it senses that there is a risk of collision between the rear side moving target and the vehicle's opening door, the DOW system activates an alert mechanism to warn the driver of the risk of door opening collision. This function is designed to enhance customer safety during parking and door opening.

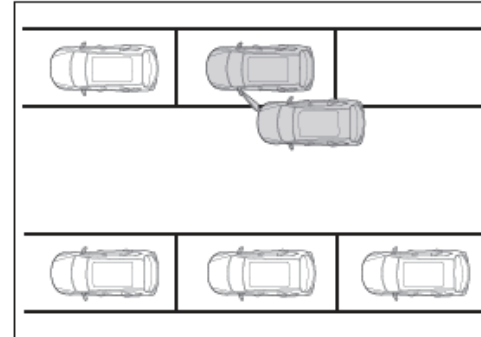

Note: The DOW function will be activated only when the vehicle is not in R gear and the vehicle speed is below 5 km/h.

Note: The function can be activated only when the vehicle is stationary or the vehicle speed is below 3 km/h; and alert can be given only when the speed of the target vehicle is greater than 10 km/h.

Starting and Driving

Monitoring area

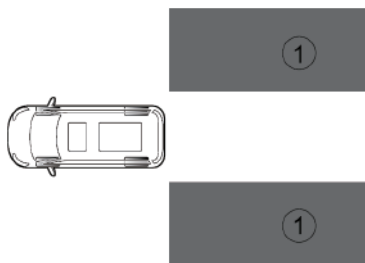

Pre-alert mode:

When a moving target enters the monitoring area ①, and the system determines that door opening presents a risk, the DOW warning light at the corresponding side will stay on.

Emergency alert mode:

After entering the pre-alert mode, when the system detects an opening door at the same side of the vehicle, the DOW warning light at the corresponding side of the vehicle will flash, a reminder will pop up on the instrument and the buzzer will sound.

Note: *The system only provides the monitoring on a limited area next to the vehicle, it cannot provide sufficient alerts for vehicles directly behind or moving targets in close proximity to the vehicle.*

Tires

! It is very dangerous to use nonconforming or damaged tires!

Do not drive the vehicle if you find a tire or tires are excessively worn, damaged or have incorrect inflating pressure.

Vehicle overload is forbidden.

Incorrect tire inflating pressure or imbalance between wheel and tire assembly may affect the vehicle stability severely, especially during driving under high load or at high speed. Under-inflation will increase rolling resistance, increase fuel consumption and accelerate tire wear, resulting in tire damage, even an accident.

Be sure to consider the situation of tires during driving. The common causes for tire faults include:

- Colliding with curb.
- Driving by a deep pit.
- Tire under-inflation or pressure overload during driving.

Wheel alignment error may lead to uneven tread wear.

Starting and Driving

Winter tires



The vehicle speed shall not exceed the maximum speed allowed by the winter tires installed. It's very likely to cause accidents due to sudden loss of pressure, thread separations or even tire blowouts when the vehicle speed exceeds the maximum allowable speed.

Always adjust the speed according to the current weather, road and traffic conditions, and never take risks with the anti-slip property of the winter tires, for fear of causing accidents!

Winter tires can improve the handling stability and the braking performance of the vehicle during its driving in low-temperature environment or on an icy road. It is recommended to change the tires to winter types when the temperature drops under 7°C.

Winter tires can significantly improve the handling stability and the braking performance of the vehicle during its driving in wintertime road conditions while the performance of anti-slip property of non-winter tires is relatively poor in low-temperature environment or on icy roads due to their structure, i.e. tire width, rubber composition, tread pattern types.

Winter tires of the same size and load index with the original ones are recommended. Install winter tires for all four wheels.

The anti-slip property of the winter tire tread will be significantly weakened when tread depth reaches 4 mm.

The maximum vehicle speed allowed by the winter tire is subject to the tire speed code.

Speed Code	Maximum Speed (km/h)
C	60
D	65
E	70
F	80
G	90
J	100
K	110
L	120
M	130
N	140
P	150
Q	160
R	170
S	180
T	190
H	210
V	240
W	270
Y	300

Starting and Driving

In addition, it is recommended to set the overspeed alert. Specific operations: the touch button on the big screen of the entertainment system controls the ON/OFF state of the overspeed alert function.

When the temperature rises over 7°C, it is recommended to replace the non-winter tires.

Tire chain

It is recommended to mount S-shape tire chains to driving wheels when the vehicle is about to run in snow.

Tire chains can improve the driving traction on road in winter. If you plan to mount tire chains, pay attention to the following points:

- 1 Not all combinations between wheels and tires are suitable for tire chain mounting. Make ensure select approved tire dimensions when mounting tire chains.
- 2 Mount the tire chains to the driving wheels. Please comply with the mounting instructions provided by the tire chain manufacturer.

Drive at the maximum speed allowed by the tire chains used only when the vehicle runs in snow. Please comply with the regulatory requirements of the resident country. Remove tire chains immediately after the vehicle runs back to the road free of snow.

Loading

In accordance with regulations, each driver is obliged to ensure his vehicle is free of overload.

Note: The maximum allowed total mass is indicated on the vehicle identification plate which is located in the lower front of B-pillar. This manual introduces correct complete vehicle mass parameters. Please refer to "Complete Vehicle Mass Parameters" in General Technical Parameters section.

Note: Fix all goods in the vehicle to prevent them from moving and accordingly causing personal injuries. The driver is obliged to ensure all goods have been fixed correctly.

In accordance with legal provisions, a vehicle carrying certain kind of dangerous good shall be marked with a specific warning sign outside.

Starting and Driving

Luggage compartment

Luggage compartment binding rings

Use the binding rings when it is required to secure and protect the objects on the luggage compartment floor. The maximum weight that the binding ring can bear is 50kg. Please withdraw the binding rings when they are not in use.

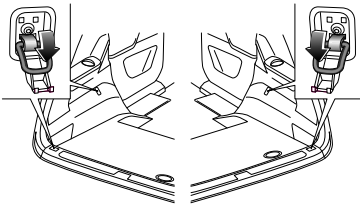

Hooks

There is a hook at both sides of the cargo area respectively. The hook is used to hold light loads, the maximum weight that it can bear is 20 kg.

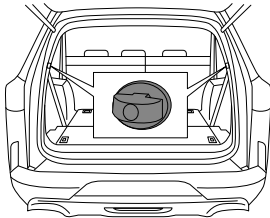

Luggage compartment net bags

The luggage compartment net bags has two types: vertical net bags and bottom net bags.

Vertical net bags

hook two lower binding straps of the net bag to the luggage compartment binding rings, and tie two upper binding straps of the net bag on the hooks, as shown in the figure below.

2

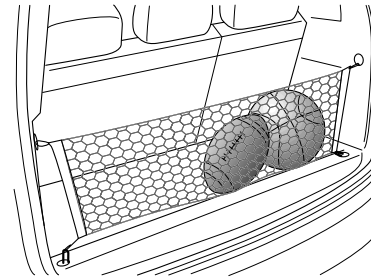

Bottom net bags

First, you need to fold the seat back of third-row seats forward until they are flat (refer to "Seats" in the Before You Drive section for specific operation), then tie four binding straps of the net bag to the binding rings, as shown in the figure below.

Starting and Driving

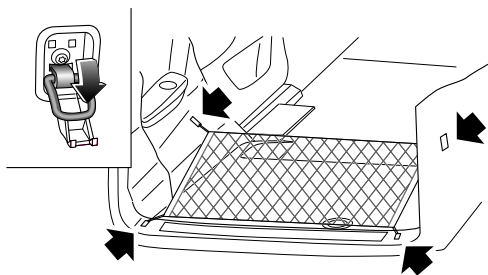

Luggage compartment storage box cover

When taking articles in the storage box under the luggage compartment lid, you may hang the hook of the luggage compartment storage box cover on the rear seat head restraint guide rod, so that the cover opens at a certain angle, to facilitate the article pickup.

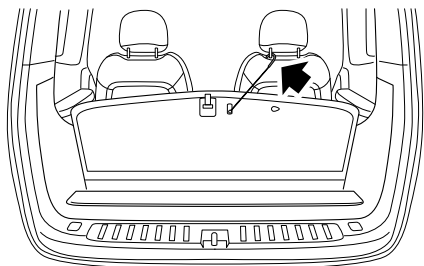

Luggage compartment cover curtain

! Do not place the luggage on the cover curtain, otherwise the cover curtain may be damaged.

Cover Curtain Usage

- 1 Firstly, take the luggage compartment cover curtain out of the luggage compartment. Take up (1) from the right end with your right hand, then take out in parallel with (2) shown in the figure.

Note: When using the cover curtain, the rear seats must be folded first for some models.

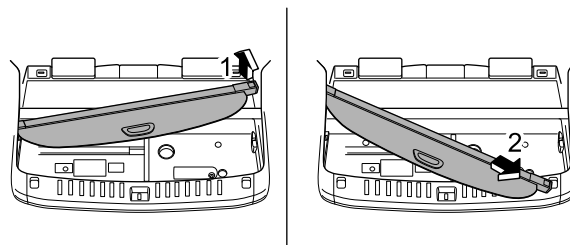

Starting and Driving

- 2 Press the button at both sides of the cover curtain to extend the cover curtain arm.

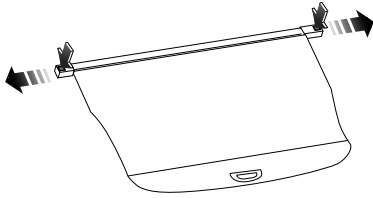

- 3 Fit both sides of cover curtain arm into the mounting holes on the rear side panel.

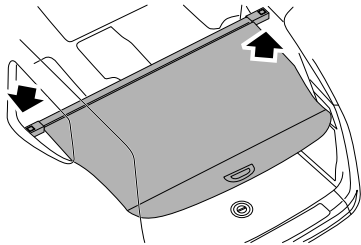

- 4 Pull out the rear side of the curtain, and then snap the mounting flange into the guide grooves on both sides of the rear opening.

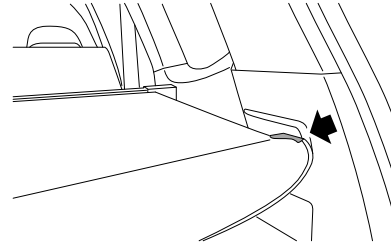

2

Cover Curtain Retraction

- 1 Shrink the support arms at the two sides of the cover curtain.
- 2 Put the left side of cover curtain into the left side of bin.
- 3 Make the end cap stuck in the slot of bin while pushing the end cap to the left.

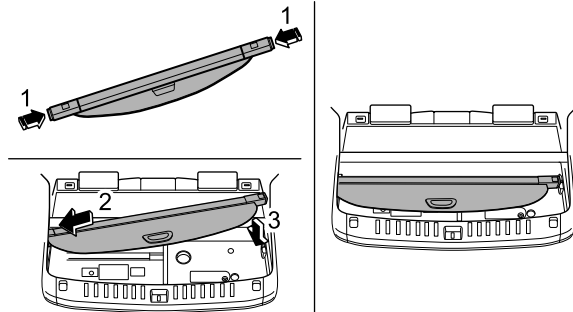

Starting and Driving

Roof rack and load carrier



Be sure to properly place the luggage on the roof rack, otherwise it may lead to an accident. Under no circumstance should the maximum roof load, maximum axle load or maximum total vehicle load be exceeded, otherwise it may lead to an accident. The roof rack with luggage carried will reduce the stability of the vehicle, especially when turning and experiencing crosswind. When heavy or bulky luggages are placed on the roof rack, the shift of the center of gravity and wind resistance may affect the vehicle handling and lead to an accident. In this case, you should adjust your driving style and speed according to the actual situations. It is not recommended to take an off-road driving when the roof rack is carried with luggages. The roof rack can only be used when the sunroof is closed, otherwise the roof rack or the luggages placed on it may endanger the surrounding person.

Vehicle handling may be affected by the carried luggages. Only install the roof rack system designed for your vehicle use. Please consult our service dealer for more information.

For the roof rack system certified by our company, the maximum load capacity during driving is 75 kg. For the certified roof rack system, its own weight is not included in the load capacity.

If other roof rack system is used, its own weight must be included in the load capacity.

The load must be evenly distributed, and cannot be left unsupported on the roof rack. After traveling 50 km, check if the roof rack and load are still firmly connected.

Emergency Troubleshooting

222 Hazard Warning Lamps

222 Warning Triangle

223 Wheel Replacement

228 Vehicle Towing

230 Fuel Filter Water Drain

231 Jump Start

233 Fuse Replacement

239 Bulb Replacement

Emergency Troubleshooting

Hazard Warning Lamps

When you need to stop or slow down the vehicle in case of a vehicle failure, always press the hazard warning lamp switch  on the instrument panel. The "Direction Indicator (green)" on the instrument cluster flashes, and all the turning signal lamps shall flash at the meantime to warn other road users as well as let the police know that you are in trouble.

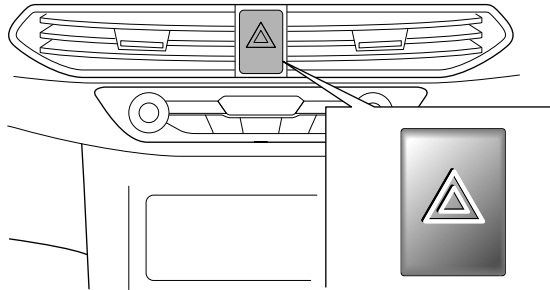

Warning Triangle

The warning triangle is placed at the bottom of the luggage compartment (for vehicles with three rows of seats) or behind the second row of seats (for vehicles with two rows of seats).

If you have to stop your vehicle on the roadside in case of a vehicle failure, you must place a warning triangle approximately 100 meters behind your vehicle to warn the oncoming vehicles.

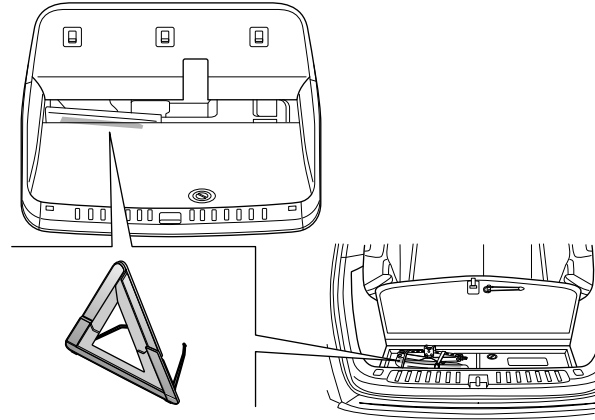

Emergency Troubleshooting

Wheel Replacement

Jack

Placement

The jack is placed at the bottom of the luggage compartment (for vehicles with three rows of seats) or behind the second row of seats (for vehicles with two rows of seats).

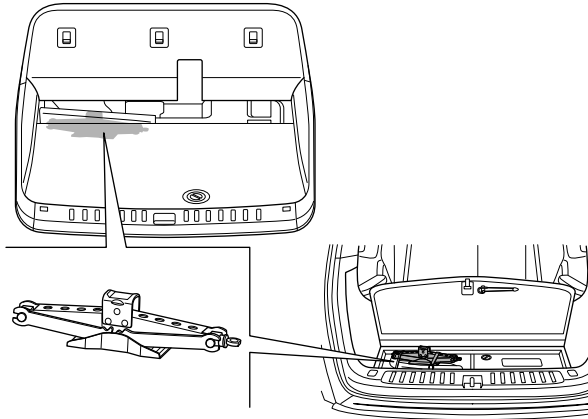

Specification

! This jack is for tire replacement only. Do not use it for other purposes. This jack is for your vehicle model only and thus should not be used for other models.

Spare wheel

! Regularly check the air pressure of spare wheel. The use of a spare wheel with incorrect tire pressure will affect wheel stability, which may lead to dangerous consequences and will cause permanent damage to the tire.

The spare wheel is mounted at the rear bottom of the body; the wheel nut wrench and jack auxiliary rotary post in the vehicle tool kit can be used to rotate the pillar bolt of drive mechanism, thus releasing or tightening the rope for the spare wheel to achieve the function of spare wheel replacement.

3

Caution

After replacing with the small size spare tire, the vehicle speed shall not exceed 120 km/h, or the risk of accident may occur. Avoid wide open throttle acceleration, hard braking and sharp turn as much as possible. It is better to replace the small size spare tire with the full size tire as soon as possible, thus to extend the service life of the spare tire and keep it in good state.

Spare wheel removal

- 1 Take out the vehicle tool.
- 2 Fold the seat back of third-row seats (if available) forward.
- 3 Mount the auxiliary rotary post and the wheel nut wrench.

Emergency Troubleshooting

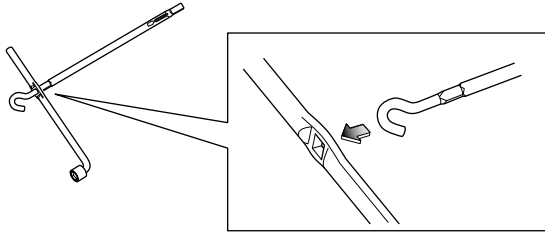

- 4 Unscrew the spare wheel rotary cap.

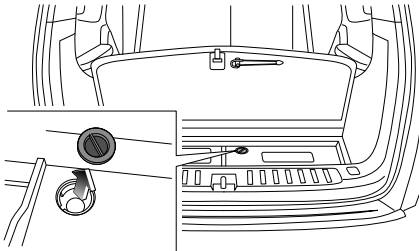

- 5 Insert the rotary post into the spare wheel loading/unloading hole through the rotary cap hole, rotate the wheel nut wrench counterclockwise to lower the spare wheel until it reaches the ground.

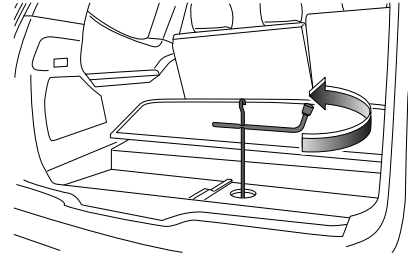

- 6 After the spare wheel reaches the ground, rotate the wheel nut wrench counterclockwise continuously and pull out the spare wheel. Excessive rotation of the wrench is prohibited, or the spare wheel device will be damaged.
- 7 Remove the tray from the spare wheel.

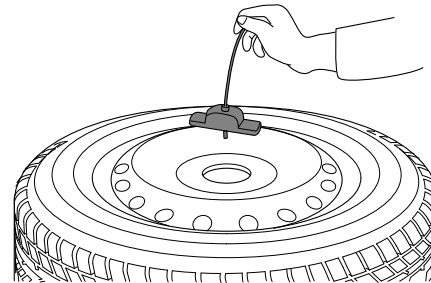

Emergency Troubleshooting

Spare wheel storage

- 1 Place the wheel on the ground with the air valve facing up (be careful not to place it reversely).
- 2 Place the wheel at the rear bottom of the vehicle.
- 3 Place the spare wheel tray in the rim center, and then adjust the tray to a proper position to allow it to be tightly connected with the spare wheel.
- 4 Rotate the wheel nut wrench clockwise until a click is heard, and the spare wheel is loaded in place.

Caution

After placing the wheel on the spare wheel holder, check whether the wheel mounting is tight. If the wheel is loose, it may fall off owing to vibration and cause an accident.

- 5 Screw the spare wheel rotary cap, and close the luggage compartment rear lid.

Wheel replacement

Vehicle parking



Please choose a solid and flat place to park the vehicle, where will neither hinder the traffic, nor throw you into a traffic accident. If your vehicle is parked on a public road, please turn on the hazard warning lamp and place a warning triangle.

Make sure that the ground where the jack is located is solid enough to support the jack and the vehicle to be lifted, or the jack may become unstable and move, thus damaging the vehicle and/or causing personal injury. Please use appropriate wheel wedges to hold other wheels.

If your vehicle is parked on a slippery place, please do not use the jack. If the conditions are not suitable for use of the jack, or you are lack of confidence to complete the task in a safe manner, please call for help. Make sure the front wheels point straight ahead.

When the engine is turned off, pull up the parking brake handle, if your vehicle is equipped with electronic parking brake system, pull up the electronic parking brake (EPB) switch to activate the electronic parking brake system, and move the shift lever to 1st/R gear (MT) or P gear (AT).

Emergency Troubleshooting

Jack placement

! The jack should be used on level firm ground wherever possible. It is recommended that the wheels of the vehicle be chocked.

No person should remain in a vehicle that is being jacked. **WARNING:** do not get under a vehicle that is supported by a jack. No person should place any portion of their body under a vehicle that is supported by a jack.

Use the jack at the specified jack point only. The height jacked up should not exceed that required by wheel replacement (for example, it should not be 30cm higher than the ground).

Before using the jack, please make sure that all occupants have left the vehicle. When the vehicle is jacked up, do not allow any person to stretch any part of his/her body under the vehicle.

During the lifting, the jack should be perpendicular to the vehicle body.

Keep the jack clean and well lubricated reapply grease every 3 months.

The jack points for front wheels are located on lower plane of longitudinal member (between the 4th cross member and the 2nd suspension). The jack points for rear wheels are located on the bracket of horizontal stabilizer bar, and the concave of the

jack should be aligned with the camber of the horizontal stabilizer bar bracket.

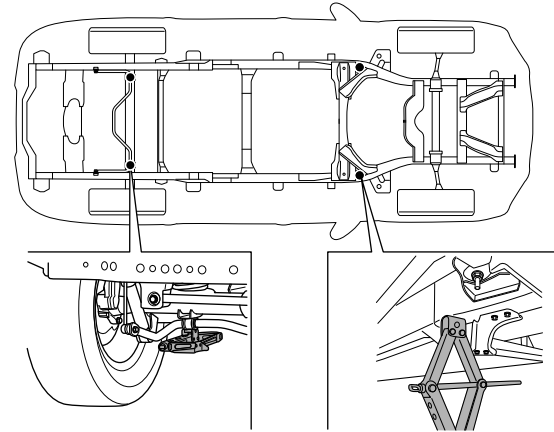

Emergency Troubleshooting

Spare wheel replacement

! During the lifting, do not start the engine. Do not stand under the lifted vehicle.

Before removing the wheel nut, make sure the vehicle is stable and will not slide or move.

It is required to use a torque wrench to accurately check the tightening torque of wheel nuts, and check the tire pressure as soon as possible after replacing the wheel.

Be sure to put the replaced wheel, jack and vehicle tool kit in the specified position. If they are placed randomly or improperly, they may move in the event of impact or emergency brake, thus causing damage or personal injury.

- 1 Remove the spare wheel, refer to "Spare Wheel" in this section.
- 2 Check whether the jack is still perpendicular to the jack point; change the position as necessary.
- 3 Use the wheel nut wrench in the vehicle tool kit to loosen the wheel nut counterclockwise.

- 4 Mount the auxiliary rotary post and then rotate the wheel nut wrench clockwise till the wheel to be replaced gets off the ground.

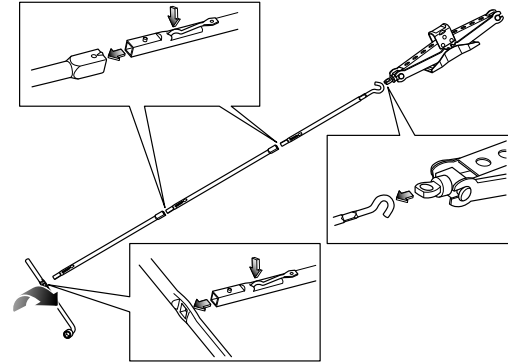

- 5 Remove the securing nuts of the wheel and then carefully remove the wheel.
- 6 Replace it with the spare wheel and then tighten the wheel nuts clockwise.
- 7 Lower the vehicle and remove the jack.
- 8 Fully tighten the securing nuts of the wheel in a diagonal order (see the diagram); the wheel nut torque is $125\pm 13\text{Nm}$.
- 9 The replaced wheel shall be loaded in the position of spare wheel, please refer to "Spare Wheel Storage" in this section.

Emergency Troubleshooting

10 Put away the replaced wheel, auxiliary rotary post of the jack, wheel nut wrench, jack and vehicle tool kit.

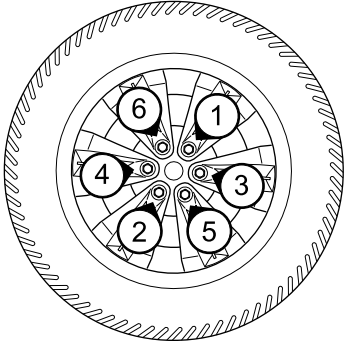

Caution

Be sure to fully lift and tighten the tray of the spare wheel device even if no spare wheel is mounted.

Vehicle Towing

When towing a vehicle or making a vehicle be towed, be sure to observe relevant national regulations on vehicle towing.

Towing eye

Front towing eye

The front towing eye is located at the lower side of front bumper.

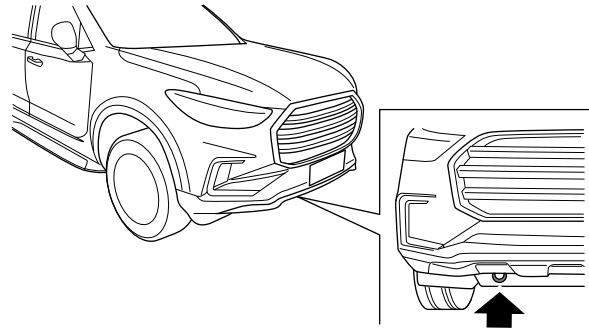

Caution

The mass that the front towing eye can bear is 1/2GVW (total mass). Do not tow a vehicle with a mass more than this value.

Emergency Troubleshooting

Rear towing eye

If it is required to tow a vehicle from rear side, remove the towing eye plug from the left side of rear bumper, and screw the rear towing eye in the vehicle tool kit into the rear bumper.

After completing the vehicle towing, unscrew the rear towing eye and place it in the vehicle tool kit, and replace the towing eye plug.

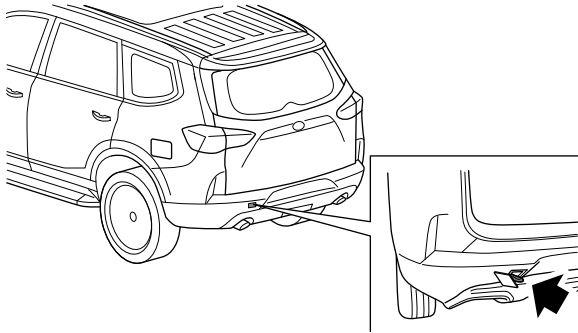

Caution

The mass that the rear towing eye can bear is 1/2GVW (total mass). Do not tow a vehicle with a mass more than this value.

The application range of towing rope is as shown below:

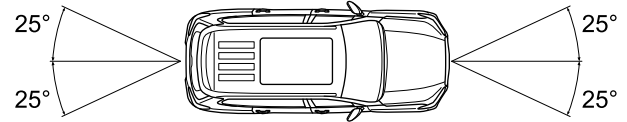

Emergency Troubleshooting

Towing

Before being towed

 To ensure the steering gear can rotate freely, turn the ignition switch to "ON" position and keep it in this position during towing process. This is to ensure the steering is unlocked, and the steering indicator and brake lamp can operate.

While being towed

When the vehicle is being towed, release the parking brake and engage N gear.

 When the engine is not operating, it is not assisted by brake booster and power steering. In this case, it needs to operate the brake pedal with larger force and rotate the steering wheel for longer time.

Caution

- When towing vehicles, for 2WD AT models, be sure to lift the driving wheels off the ground, and maintain the towing speed less than 50km/h. When the towing distance is less than 50km, place the shift lever in N gear.
- When towing vehicles, for 2WD MT models, the shift lever must be placed in N gear.
- When towing vehicles, for 4WD models, please tow the whole vehicle with a flat bed trailer.

Fuel Filter Water Drain

Note: It applies to vehicles equipped with diesel engine.

 Be sure to wear proper gloves to protect hands from touching diesel.

Drain water according to the following steps:

- 1 Turn the ignition switch to "LOCK" position.
- 2 Put a proper container under the fuel filter drain bolt and unscrew the drain bolt (1) with a proper tool.
- 3 Drain till clean diesel appears, then re-tighten the drain bolt (1) to 2 ~ 2.5 N.m.
- 4 Start the engine. "Fuel filter water level warning lamp (yellow)" shall go out in 2 seconds. Check the filter for fuel leakage.

Caution

If "fuel filter water level warning lamp" on the instrument cluster illuminates during driving, please park the vehicle in a safe place, shut down the engine and drain water.



Do not pour diesel fuel into domestic or public sewage system. Please use locally approved waste treatment equipment.

Emergency Troubleshooting

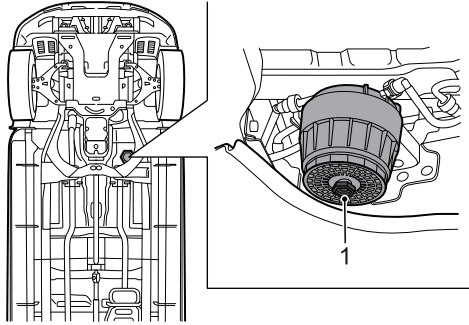

Jump Start

Battery disconnection

! Wear protective gloves and goggles during the operations related to battery.

Do not use open fires, generate sparks or smoke in the battery area. Or you will be injured and the vehicle will be damaged.

To disconnect the battery, be sure to disconnect the negative (-) grounding terminal first and then the positive (+) one. When connecting the battery, please install and tighten positive cable (+) first and then negative (-) cable. And cover the terminals with Vaseline.

3

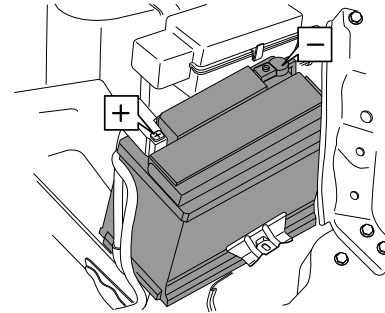

Emergency Troubleshooting

Caution

- Before disconnecting the battery, be sure to shut down the engine and turn off all electrical appliances for more than 2 minutes. Please avoid the terminals from contacting with metal components of the body during disconnection. The resulted short circuit may generate electric sparks.
- Reverse connection of positive and negative cables will cause damage to electrical system.

Jump start



It is never allowed to start the vehicle by pushing or towing.

Make sure that both batteries are of the same rated voltage (12V), and the jumper cables are approved for use with 12V car batteries.

Jumper

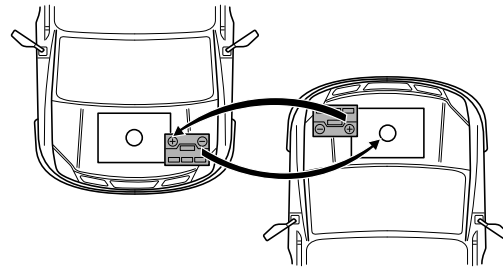

- 1 Make two vehicles close enough.
- 2 Shut down the engine and turn off all electrical equipment.
- 3 Connect the positive terminals (+) of both batteries with a red jumper cable.
- 4 Connect a black jumper cable between the negative terminal (-) of power supply battery and the grounding point (not negative terminal) of the battery to be charged.

Emergency Troubleshooting

- 5 Make sure all connecting devices contact well.
- 6 Check whether jumper cables contact with any moving parts when engine starts.
- 7 Check whether the parking brake handles of both vehicles have been engaged and whether the shift lever is in N gear.

Starting

Start the vehicle with power supply battery and allow it idle for several minutes.

- 1 Start the vehicle with battery to be charged.
- 2 Allow the engine idle for 2 minutes and above after it is started.

Note: *If it fails to start after several attempts, the vehicle probably needs service.*

Disconnection

- 1 Shut down the engine of the donor vehicle.
- 2 Make sure the wire terminals will not contact with each other and will not contact any moving parts of engine during disconnection.
- 3 Remove the jumper cables. Removal is the reverse of connection.

Fuse Replacement

Fuses of this vehicle are respectively placed in two boxes.

Caution

Any electrical components of the vehicle will be damaged after being splashed with fluid. Be sure to cover any electrical components. The contents in the fuse specification list are subject to continuous modification according to vehicle configuration and technical state. Please follow the list based on actual condition of your vehicle.

3

Driver compartment fuse box

Driver compartment fuse box is located behind the lower storage box at driver side.

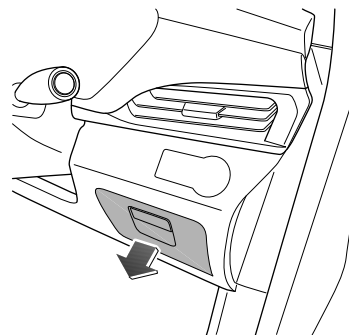

Emergency Troubleshooting

Fuses in the driver compartment fuse box can be identified by the label on the back of lower storage box cover at driver side.

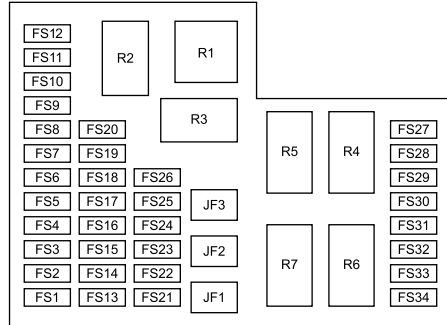

Specifications of driver compartment fuse

Fuse	Specification	Function
FS1	15A	Heated steering wheel
FS2	10A	IG power: IMMO base station/instrument cluster/body control module
FS3	10A	IG Power : supply airbag control module
FS4	15A	PEPS controller
FS5	10A	IG power: auto anti-dazzle rearview mirror/LDWS/LKA
FS6	10A	IG power: front A/C panel/EPB switch/rearview mirror adjusting switch
FS7	7.5A	Lane departure aid
FS8	25A	Front sunroof/Sunshade
FS9	25A	Passenger's side power seat
FS10	25A	Driver's side power seat

Fuse	Specification	Function
FS11	15A	ACC4(Cigar lighter)
FS12	10A	Active noise control
FS13	10A	TBOX/12-inch display screen
FS14	10A/15A	Ignition switch/(PEPS ECU/kick sensor)
FS15	10A	Front blower feedback
FS16	10A	Rear blower feedback
FS17	10A	ACC2(Wireless charging module/occupant door power window switch/rearview mirror adjustment switch/front blower/power sunroof)
FS18	10A	ACC3(Audio power amplifier/antenna/radio)
FS19	15A	ACC1(Right rear 12V outlet)
FS20	30A	Power amplifier
FS21	10A	Instrument cluster
FS22	15A	Automatic transmission
FS23	25A	MP5/Radio
FS24	10A	Diagnosis interface
FS25	10A	Front A/C control panel/lumbar/driving mode switch/trunk lamp/ambient lamp/air purifier
FS26	/	Reserved
FS27	/	Reserved
FS28	/	Reserved
FS29	25A	Driver's side power window lifter
FS30	25A	Passenger's side power window lifter
FS31	/	Reserved
FS32	/	Reserved
FS33	/	Reserved
FS34	10A	Rear view mirror heating
JF1	30A	Digital fan(used for diesel engine vehicles)
JF2	40A	Power seat

Emergency Troubleshooting

Fuse	Specification	Function
JF3	30A	Panoramic sunroof
R1	/	Front blower relay
R2	/	ACC relay
R3	/	IG relay
R4	/	Trunk light relay
R5	/	Rear view mirror/Rear window heating relay
R6	/	Digital fan relay(used for diesel engine vehicles)
R7	/	Puddle lamp relay

Front compartment fuse box

The front compartment fuse box is located at the right of compartment wall at the front hood bottom and behind the right headlamp (viewed from the front of vehicle).

Type I

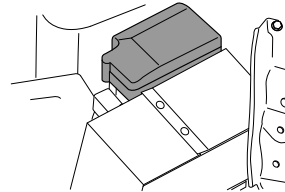

Type II

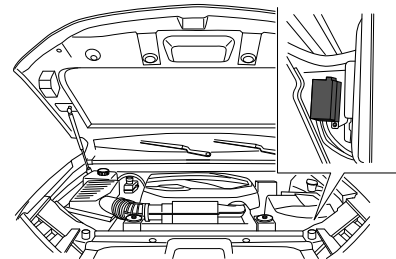

Emergency Troubleshooting

Caution

Before opening the fuse box cover, make sure its surroundings are dry and no fluid flow from any direction into the opened fuse box, otherwise the fuse box will be damaged, leading to serious consequences.

Fuse can be accessed by just removing the cover of front compartment fuse box. Fuses in the front compartment fuse box can be identified by the label printed at the back of the fuse box cover.

Type I

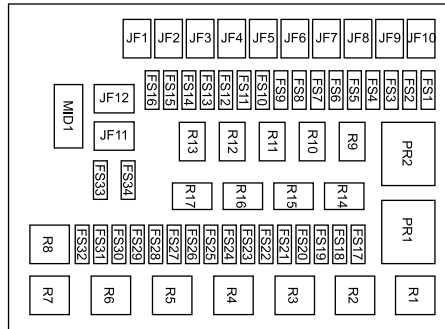

Type II

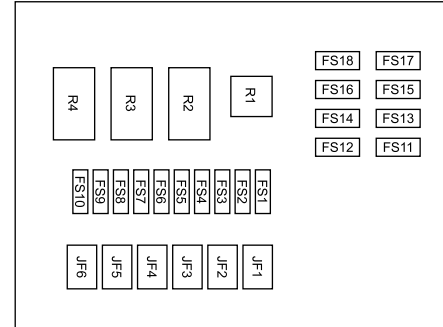

Specifications of front compartment fuse

Type I

Fuse	Specification	Function
FS1	10A	KL30 PWR
FS2	25A	Heated rear window/rearview mirror/cargo lamp
FS3	30A	IEC power supply 5
FS4	25A	Fuel pump
FS5	25A	ABS/ESP valve
FS6	15A	Engine control module
FS7	30A	Front wiper
FS8	15A	Electronic water pump(used for gasoline engine vehicles)
FS8	15A	SCR relay power(used for diesel engine vehicles)

Emergency Troubleshooting

Fuse	Specification	Function
FS9	15A	A/C compressor/battery sensor
FS10	30A	IEC power supply 3
FS11	25A	Fog lamp/position lamp/daytime running lamp
FS12	25A	IEC power supply 8
FS13	25A	Low beam
FS14	20A	High beam
FS15	30A	IEC power supply 2
FS16	30A	IEC power supply 4(used for gasoline engine vehicles)
FS16	30A	BCM KL30(used for diesel engine vehicles)
FS17	/	Reserved
FS18	15A	Front lambda oxygen sensor(used for gasoline engine vehicles)
FS18	20A	Nitrogen oxygen sensor/PM sensor(used for diesel engine vehicles)
FS19	5A	Rear oxygen sensor(used for gasoline engine vehicles)
FS19	15A	WCAC coolant pump(used for diesel engine vehicles)
FS20	15A	Ignition coil(used for gasoline engine vehicles)
FS20	15A	Engine harness inline supply
FS21	15A	Main relay power supply
FS22	20A	Horn
FS23	10A	Starter feedback(used for gasoline engine vehicles)
FS24	10A	Rear fog lamp/position lamp/daytime running lamp
FS25	10A	Rearview mirror folding/tailgate/fuel tank cap
FS26	25A	Central lock
FS27	10A	BCM_interior lamp/vanity/mirror/rain light sensor

Fuse	Specification	Function
FS28	15A	Left high beam
FS29	15A	Right high beam
FS30	15A	Left low beam
FS31	15A	Right low beam
FS32	10A	Headlamp leveling
FS33	25A	Exterior lamps
FS34	15A	Washer/rear wiper
JF1	30A	Main relay
JF2	50A	Electronic parking
JF3	30A	Starter
JF4	30A	IG power supply
JF5	60A	ACC power supply
JF6	40A	IEC power supply 9
JF7	40A	DC stabilizer 2
JF8	40A	ABS/ESP_motor
JF9	40A	Front blower
JF10	40A	Rear blower
JF11	60A	Power window(used for gasoline engine vehicles)
JF11	60A	IEC power supply 1(used for diesel engine vehicles)
JF12	60A	IEC power supply 6
MID1	100A	Cooling fan
PR1	/	PTC1 relay
PR2	/	PTC2 relay
R1	/	SCR relay(used for diesel engine vehicles)
R2	/	PTC3 relay
R3	/	Horn relay
R4	/	Starter relay
R5	/	Fuel pump relay

Emergency Troubleshooting

Fuse	Specification	Function
R6	/	Wiper power relay
R7	/	Wiper speed relay
R8	/	Main relay
R9	/	A/C compressor relay
R10	/	Rear fog lamp relay
R11	/	Position lamp relay
R12	/	Left front fog lamp relay
R13	/	Right front fog lamp relay
R14	/	Low beam lamp relay
R15	/	High beam lamp relay
R16	/	Left daytime running lamp relay
R17	/	Right daytime running lamp relay

Type II

Fuse	Specification	Function
FS1	20A	Inverter
FS2	10A	Gateway
FS3	10A	Differential lock controller
FS4	25A	Left rear power window
FS5	10A	Tire pressure monitoring/360 BSV
FS6	15A	Front seat heating
FS7	15A	Rear seat heating
FS8	30A	TCCU power supply 1
FS9	30A	TCCU power supply 2
FS10	25A	Right rear power window
FS11	30A	ACC 1(Left rear 12V power socket/central 12V power socket)
FS12	10A	ACC 2(220V vehicle inverter/gateway/USB/rear blower/left rear door power window switch/right rear door power window switch)

Fuse	Specification	Function
FS13	10A	IG power supply 1
FS14	10A	IG power supply 2
FS15	10A	IG power supply 3
FS16	10A	IG power supply 4
FS17	15A	Front axle clutch
FS18	30A	Diesel filter relay power(used for diesel engine vehicles)
JF1	60A	GCU(used for diesel engine vehicles)
JF2	40A	HCU(used for diesel engine vehicles)
JF3	40A	PTC1
JF4	25A	Power liftgate controller
JF5	40A	PTC2
JF6	40A	PTC3
R1	/	ACC relay
R2	/	Diesel filter relay(used for diesel engine vehicles)
R3	/	Rear blower relay
R4	/	IG relay

Fuse replacement



Replace only with the fuse of identical specification or rated current. Installation of non-specified fuse will cause damages to electrical system and even cause fire. Turn off the ignition switch and power off all electrical equipment before replacing the fuse. Any unauthorized change to electrical system of the vehicle will cause serious adverse effects to electrical management system and cause fire.

Emergency Troubleshooting

Pull out the fuse with a puller provided in the fuse box to remove the fuse. Determine whether the fuse is blown according to wires inside the fuse (as indicated by the arrow).

Note: Repeated failure with the same fuse is the indication of circuit failure. Please contact our Service Dealer as soon as possible.

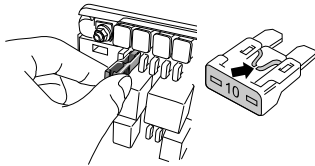

Caution

Unauthorized change to electrical system of the vehicle will invalidate the warranty.

Bulb Replacement

Before replacing any bulb, turn off the ignition switch and lighting switches to avoid any possible short circuit. When removing or installing the bulb, do not touch the bulb with hands. If touched, wipe away the hand print with a piece of cloth or alcohol.

Caution

The bulb replacement must be identical with the original one in type and specification.

Bulb specification

Bulb	Specification
Low/high beam	HIR2
Front turning signal lamp	PY21W
Front fog lamp	H11
Rear turning signal lamp (type I)	PY21W
Reverse lamp (type I)	W21W
Brake lamp/rear width lamp (type I)	P21/5W
Rear turning signal lamp (type II)	WY21W
Reverse lamp (type II)	W21W
License plate lamp	W5W
Front ceiling reading lamp	W5W
Rear ceiling reading lamp	W5W

Emergency Troubleshooting

Bulb replacement

The method for bulb removal is shown below. For other bulbs to be replaced but not in the list, please contact with authorized service provider immediately. Installation of bulb is the reverse of removal, which will not be covered here.

Front Combination Lamp

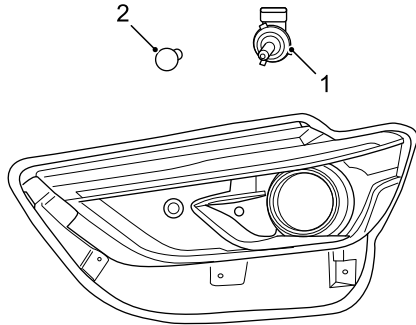

1 Low/High Beam

Open the engine hood, then you can find it at the rear of front combination lamp:

- Rotate the bulb cover counterclockwise to remove it.
- Remove the low/high beam bulb.

2 Front Turning Signal Lamp

Open the engine hood, then you can find it at the rear of front combination lamp:

- Rotate the bulb cover counterclockwise to remove it.
- Remove the bulb of turning signal lamp.

Rear Ceiling Reading Lamp

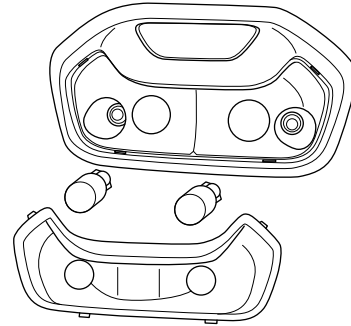

Carefully pry up the lamp shade with a screwdriver or equivalent.

Remove the bulb of rear ceiling reading lamp.

Maintenance and Service

- 242 Safety
 - 243 Regular Maintenance
 - 243 Owner Checks
 - 244 Front Compartment
 - 246 Engine Hood
 - 247 Engine Oil
 - 249 Coolant
 - 251 Brake Fluid
 - 252 Washer Fluid
 - 252 Washer Nozzles
 - 253 Wiper Blade
 - 254 Seat Belt
 - 255 Battery
 - 258 Tires
 - 261 Other Maintenance
-

Safety

During vehicle inspection or maintenance, take care to reduce risks of personal injury or vehicle damage, and always observe the following safety precautions.



Turn off the ignition switch and pull out the key, unless otherwise specified in special procedures.

When the engine is running, be sure to keep hands, tools and clothes away from drive belt and belt pulley.

Radiator fan may start at any time (even when the engine is not running). Always ensure your hands, loose clothing (such as ties, scarves, etc.) stay away from fan blades.

After the engine is starting/running, many components under the engine hood will be hot, such as engine, exhaust system, cooling system and power steering fluid reservoir, etc. Do not touch until it is cooled down.

Do not touch wires or components with the ignition switch in "ON" position. Keep in mind that the batteries and wires carry with high current or voltage possibly causing personal injury. Avoid short circuit.

Do not start the engine in unventilated place as poisonous gases exhausted is very dangerous.

If possible, operate the engine compartment after engine shut-down and battery disconnection (refer

to "Jump Start" in Emergency Troubleshooting section). If components under the engine hood shall be inspected when the engine is running, make sure the vehicle is on a level ground, the parking brake handle has been pulled up and the shift lever is in N or P position. Keep match and open fire away from the battery area and all fuel related components. Do not smoke near these areas and components.

Most fluid used for motor vehicles are toxic. Do not drink or contact with skin or eye. These fluid include battery acid, coolant, brake fluid, power steering fluid, fuel, detergent, lubricating oil, refrigerant, etc. Please wear protective gloves to refill the fluid. And observe all instructions on labels and containers. When operating on or under the vehicle, wear protective glasses if it is possible to touch splashed or fallen articles and sprayed fluid.

Long-term contact with engine oil may cause skin diseases, including dermatitis and skin cancer. Clean it thoroughly after contact.

Be sure to keep children and pets away from the vehicle. Nobody is allowed to stay in the vehicle (except those work in the vehicle according to your instruction). Be sure to keep children away from oil, fluid and lubricating grease.

Regular Maintenance

Regular maintenance of the vehicle will be beneficial to the economy, safety and reliability of your vehicle. It is important to remember that the responsibility for ensuring vehicle safety and suitable for road travel is ultimately your own (owner / operator).

Specify the maintenance required and interval for it to maintain your vehicle properly. Please go to Service Dealer for regular maintenance of the vehicle in accordance with the provisions in the "Warranty and Maintenance Manual".

Regular maintenance of your vehicle in accordance with the requirements will ensure your best interests.

Our Service Dealer has qualified personnel, required equipment and pre-established maintenance plan, which can provide the most reliable service for the vehicle. Therefore, it is recommended to carry out regular maintenance at our Service Dealer.

Owner Checks

To ensure the reliability and economy of driving, the vehicle owner must carry out the following simple but important checks:

Daily check

- The function of lighting (make sure all lens are clean), horn, instrument cluster, warning lamps and indicator lamps, wipers and washers.
- Whether the seat belt is intact.
- Whether the brakes operate normally.
- Visually check if there is water, oil, fuel, exhaust fume and other leakage under the vehicle.

Maintenance and Service

Weekly check or check before a long trip

- Check fluid level / refill.
 - Engine Oil
 - Coolant
 - Windshield Washer Fluid
 - Power steering fluid
 - Brake fluid
- Check the condition and pressure of all tires (including spare wheel).
- Check and operate air conditioning system.

Severe working conditions

It is advised to shorten the maintenance interval if the vehicle is used in severe working conditions frequently.

Please go to Service Dealer for regular maintenance of the vehicle in accordance with the provisions in the "Warranty and Maintenance Manual".

Front Compartment

Gasoline engine vehicles

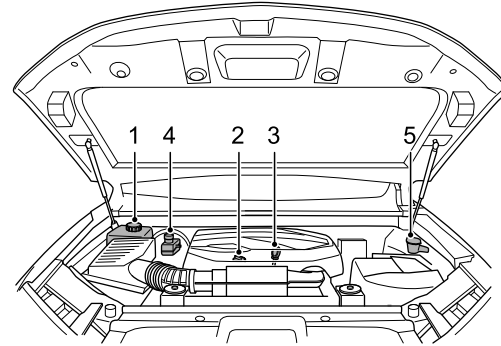

- 1 Engine coolant reservoir
- 2 Oil filler cap
- 3 Oil dipstick (blue)
- 4 Brake fluid reservoir
- 5 Washer fluid reservoir

Diesel engine vehicles

Type 1

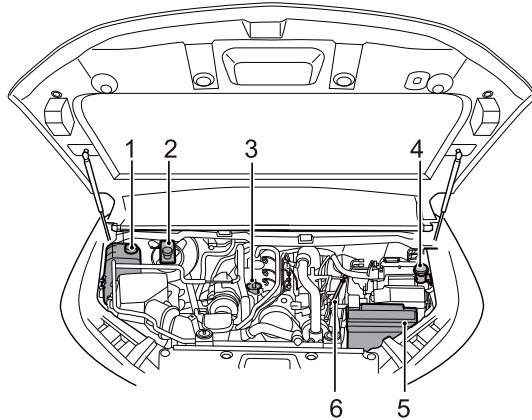

- 1 Engine coolant reservoir
- 2 Brake fluid reservoir
- 3 Oil fill cap
- 4 Washer fluid reservoir
- 5 Battery
- 6 Oil dipstick

Type 2

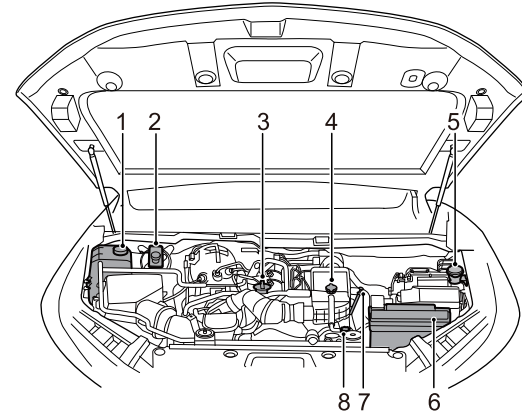

- 1 Engine coolant reservoir
- 2 Brake fluid reservoir
- 3 Oil fill cap
- 4 Water-air intercooler pressure cap
- 5 Washer fluid reservoir
- 6 Battery
- 7 Oil dipstick
- 8 Water-air intercooler coolant reservoir cap

Engine Hood

Open the engine hood

Pneumatic Rod

- 1 Pull the engine hood release lever below the splash guard at driver side to unlock the engine hood.

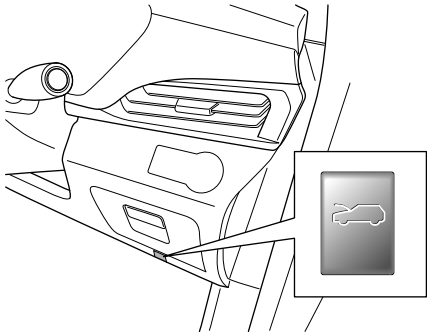

- 2 Slightly raise the front part of the engine hood, push the lever to the right and lift the engine hood.

Close the engine hood

! When the ignition switch is in "ON" position, the radiator fan may start at any time (even if the engine is not running). Always ensure your hands, loose clothing (such as ties, scarves, etc.) stay away from fan blades.

If the engine is running, keep your hands, clothing, etc. away from the rotating pulley, drive belt, fan blades and other devices.

Pneumatic Rod

Press down on the front part of the engine hood until you hear the sound which indicate the latch is snapped. Try pulling the engine hood up to check if the locking mechanism is properly snapped.

Caution

Before closing, check if there is any tool, cloth, equipment or etc. left in the area under the engine hood.

Engine Oil

It is recommended to use the oil of correct grade, please refer to "Recommended Fluids" in the General Technical Parameters section for the specifications.

Our authorized dealers are willing to provide you with the latest changes and improvements on the recommended oil. If the temperature in your area is extremely low (below -30°C), it is recommended to use special oil for winter use in your engine. Please contact our authorized dealers for details.

Caution

Do Not use oil that does not meet the requirements of the specified grade. Improper use of the oil can cause damage to the engine and void warranty.

Check and refill



Do not exceed the maximum mark when refilling.

Long-term frequent exposure to used engine oil can cause severe skin disease. Please avoid excessive skin contact with engine oil, in case of contact, rinse your skin thoroughly.

Keep the engine oil out of the reach of children and pets.

Park the vehicle on a flat ground, idle the engine for 1 ~ 2 minutes, then turn off the ignition switch and wait for about 10 minutes to check the oil level.

Pull out the oil dipstick and wipe the blade with a paper or lint-free cloth. Completely insert the oil dipstick back and then pull out.

Gasoline engine vehicles

The oil level indication must be between "MAX" and "MIN".



Maintenance and Service

Diesel engine vehicles

The oil level indication must be between "MAX" and "MIN".



Caution

Check the engine oil level frequently, and refill as necessary. Both excessive and insufficient refilling of engine oil is likely to damage the engine, and the damage are not covered by warranty.

If you need to refill, please unscrew the oil filler cap, then add new oil of correct specification in several times and in small quantities. Repeat the oil level check process after the oil drops into the tank. Refill as necessary until the oil level is correct.



Empty containers and used oil can not be discarded randomly, so as to avoid environment pollution.

Gasoline engine vehicles

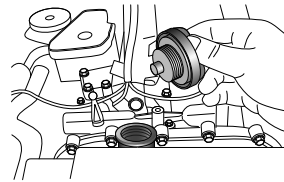

Diesel engine vehicles

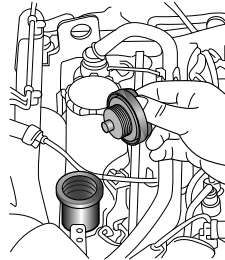

Engine oil consumption

The engine oil consumption is affected by a variety of factors (these factors also affect fuel consumption), of which the oil type and driving pattern (especially in the "running-in" period) are the two most important factors. Generally, the engine oil consumption is higher in the "running-in" period and in continuous high-speed operation. You must follow the suggestions on driving tips in this manual. Please refer to "Driving" in Starting and Driving section.

Coolant



The coolant is harmful, Don't swallow it. Do not allow coolant come into contact with your skin and eyes. In case of contact, rinse with plenty of clean water immediately .

The coolant of correct specification can not only protect the engine from frozen damage , but also offer corrosion protection throughout the year. If coolant of correct specification is not added, do not drive the vehicle. Refer to "Recommended Fluid" in the General Technical Parameters section for the coolant specification.

The fluid in the cooling system must be discharged at a specified interval, then the system shall be rinsed, and the appropriate amount of coolant should be refilled.

Caution

Only use the specified coolant for filling or replacing. If a non-recommended coolant is used, the cooling system may be damaged and the warranty may become invalid.

Maintenance and Service

Check and refill

! Do not remove the expansion tank cap while the system is hot, for escaped water vapor or hot coolant may cause injury. If you have to add coolant when the engine is hot, please wait for 10 minutes, cover a thick cloth on the expansion tank cap, slowly rotate the coolant reservoir cap counterclockwise to release the pressure inside the coolant reservoir, and then remove the reservoir cap.

Be sure to check the coolant level when the vehicle is parked on a flat ground and the engine is not running (in cold state).

The fluid level is visible on the expansion tank, and the normal level should be between the "MAX" (the maximum amount) and "MIN" (the minimum amount) marks.

If the level drops to the "MIN" mark, clean the area around the coolant reservoir cap and rotate the reservoir cap counterclockwise to remove it. Refill the specified coolant to the level between "MAX" (the maximum amount) and "MIN" (the minimum amount). Replace the reservoir cap.

Note: *The coolant may expand which it becomes hot, so the liquid level may be higher than the level mark.*

Note: *Excessive refill may cause the coolant overflow when the engine temperature rises, which undermines the cooling effect. Simply refill the fluid to the indicated level when the engine is cool.*

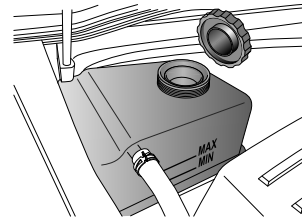

Caution

If the fluid level drops significantly or frequent refilling is required, consider if leakage or overheat conditions exist. If so, contact our Service Dealer for service as soon as possible.

Precautions in cold weather

To reduce the possible problems caused by the use of coolant in cold weather, the following recommendations should be taken into consideration:

- The standard freezing point of coolant used in the vehicle is -35°C (the mixture ratio of coolant and water is 1:1), therefore it is required to park the vehicle in an area that can maintain the coolant temperature above -35°C .
- When the vehicle is used in an extremely cold area where the temperature is lower than -35°C , a suitable proportion of coolant based on the local temperature is recommended. (Refractometer T10007 can be used to detect the freezing point of coolant.)

Brake Fluid

! If the brake fluid level drops obviously, contact Service Dealer for service as soon as possible.

Only new brake fluid of specified type can be used. Using brake fluid which is used or of non-specified type may impair the brake performance.

It is crucial to keep the brake fluid clean. If any dust enters in the system, it may result in brake performance decline.

Don't allow brake fluid to contact your skin and eyes, In case of contact, rinse with plenty of water . Keep the brake fluid out of the reach of children.

Do not allow brake fluid flowing onto the engine, otherwise it may be ignited when the engine heats up, causing a fire and damage to the engine.

Note: Fluid used by the hydraulic clutch also comes from the brake fluid reservoir.

Caution

- Only the brake fluid that conforms to the DOT4 specification can be filled in the master cylinder of the brake. Do not use brake fluid of other types.
- If the brake fluid contacts the paint, it will cause damage to the paint. Wipe clean immediately and rinse with clean water.

Check and refill

Be sure to check the brake fluid level after the vehicle is parked on a flat ground and the system is in cold state. The brake fluid level is visible on the reservoir, and the normal level should be between the "MAX" (the maximum amount) and "MIN" (the minimum amount) marks. If the level drops to the "MIN" mark, clean the area around the fluid refill cap and rotate the reservoir cap counterclockwise to remove it. Refill the specified new brake fluid to the level between "MAX" and "MIN", then replace the reservoir cap.

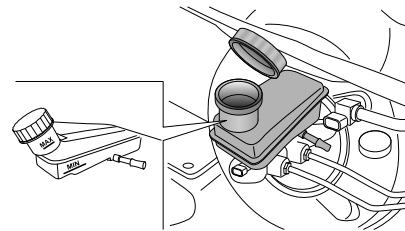

If the level is lower than the "MIN" mark, "Brake System Warning Lamp (red)" on the screen of information center will illuminate. It indicates that the brake system is malfunctional. Figure out the reason immediately. If you are driving, stop the vehicle carefully and immediately. Please contact our Service Dealer for service as soon as possible. Do not continue to drive.



Do not discard the used brake fluid randomly, so as to avoid environment pollution.

Maintenance and Service

Washer Fluid

Check and refill

! It is dangerous to drive the vehicle while the washer system is inoperative. be sure to check the system before driving.

The windshield washer fluid reservoir is located in the engine compartment. When refilling is needed, please lift the front part of the refilling cap to add the washer fluid, and then close the cap. Refer to "Recommended Fluid" in the General Technical Parameters section for washer fluid specifications.

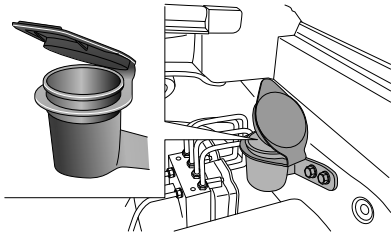

Caution

Don't use unqualified washer fluid. Don't use tap water since the mineral substance in tap water will block the pipe or nozzle of the windshield washer fluid.

Washer Nozzles

Adjust and clean

Front Washer Nozzle

Front washer nozzle is not adjustable.

Make sure that the washer reservoir contains washer fluid before cleaning the nozzle. If the nozzle is blocked, carefully clean it with a fine line or needle.

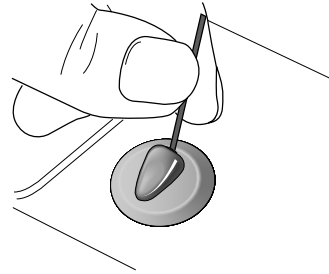

Rear Washer Nozzle

Rear washer nozzle is not adjustable.

Wiper Blade

Check

Check the edge of wiper blades for roughness or damage, and check if the blade rubber is secure from top to bottom.

Note: If there are grease or other impurities on the rubber blades, it may cause the wiper work improperly and may damage the windshield.

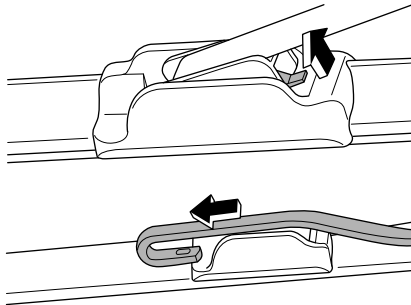

Replacement

Removal

- Lift the wiper arm from the windshield to make an angle of about 15 degrees between the blade and the arm.
- Push the retaining clip (in the direction of the arrow), slide the blade bracket along the direction of the arrow to the arm so as to loosen the pivot of the bracket from the hook of the arm.

Note: Remember the relative location of hook and bracket because the replacement blade is required to be fitted later in the same way.

Installation

- Install the blade holder on the hook.
- Snap the pivot into the hook and push it in place, until hearing an audible sound of snapping into place.

Maintenance

Wash it with high-quality or neutral detergent, and wipe with a lint-free dry soft cloth.

Seat Belt

Check



The seatbelt is equipped with a sensitive retractor, which will be locked only in hard acceleration, deceleration or drastically bend.

Don't test the locking device by fiercely and intentionally bending your upper body forward.

Check all the seat belts as shown below:

- Check all the seat belt anchor point for safety.
- Insert the locking tab into the buckle and check if the locking action is definite. Push the red button and check if the locking tab pops neatly.
- With the belt partially loose, hold the locking tab and pull it suddenly. Check if the safety device can be locked automatically and prevent further looseness.

Maintenance



Don't try to fix retractor or buckle mechanism by any means or modify the seat belt. If the seat belt has been stretched in the event of an accident, please ask Service Dealer to replace it and check the anchor point.

Check the seat belt webbing for signs of scratch or wear on a regular basis, and pay special attention to the anchor point and adjuster.

Clean the seat belt with a sponge dipped in warm water and mild soap; it can be naturally dried, and should not be directly heated or exposed to sunlight. Do not allow water penetrating into the retractor. Never bleach or dye the seat belt, as doing so may reduce its strength.

Battery

Warning notice on battery:



Wear glasses!



Wear protective gloves and glasses since battery acid is highly corrosive!



Open flames, electric sparks, strong light and smoking are prohibited!



Explosive mixed gas may be produced during battery charging!



Children should be kept away from acid and battery!



Risk of injury, corrosion, accident and fire exists when operating on vehicle battery and electrical appliance!

Wear protective glasses. Prevent acidic or lead particles from falling into eyes, on skin or clothes.

Wear protective gloves and glasses since battery acid is highly corrosive! The battery can not be turned over because the acid may flow out of the air vent. If the acid splashes into eyes, wash with clean water for a few minutes, then go to see a doctor immediately. If the acid splashes on skin or clothes,

immediately neutralize it with rich soap solution and rinse with plenty of water. If you mistakenly drink acid, go to see a doctor immediately.

Open flames, electric sparks, strong light and smoking are prohibited! Avoid sparking when handling cables and electrical equipment and removing electrostatic loads. Battery electrode must not be short-circuited because sparks with high energy pose a risk of injury.

Battery charging may produce explosive mixed gas, you must ensure that the battery air vent is open to successfully discharge the gas. The battery should be located in a well ventilated space during charging.

Children should be kept away from acid and battery.

Turn off the engine, ignition switch and all the electrical appliances before working on electrical appliances. Remove the battery negative cable. Turn off the lamp in bulb replacement.

Please pay attention to the polarity of power supply. check if the polarity of power supply matches before energizing.

Each energizing period should not be less than 5 seconds, to avoid frequent or fast on and off operation.

Maintenance and Service

 **First remove the negative cable, then the positive one to remove the battery.**

Turn off all the electrical appliances before energizing the battery again. First connect the positive cable, then the negative one. Do not connect the wrong cable - Risk of fire!

Unauthorized removal and installation of battery are prohibited, because in some cases, this operation will lead to serious damage to the battery and fuse box. Please contact Service Dealer.

Do not disconnect the battery when the ignition switch is on or the engine is running, otherwise it may damage the electrical appliances (electrical components).

To prevent the battery case from being exposed to ultraviolet light, do not expose the battery to sunlight.

Car parking period

If the vehicle is to be parked for an extended period of time, the static current electrical appliance (like clock, security devices) will drain the battery, and the battery has to be recharged. To avoid such case, charge the battery or disconnect the battery negative cable during the vehicle parking.

Note: Please pay attention to the warnings & instructions for battery before working on it.

Caution

Always turn off the ignition switch when parking, otherwise, it will greatly reduce the parking time.

Winter operation

Vehicle battery has particularly stringent requirements in winter. In addition, the starting power provided by battery at low temperature is only part of that at room temperature. So we recommend that before the cold season comes, it is better to have vehicle battery checked at Service Dealer, and recharge it as necessary.

If the vehicle will not be in use for a few weeks in an extremely cold situation, you should remove the vehicle battery and store it in an unfrozen room so that it will not be frozen and damaged.

Battery charge with ground equipment

 **Don't charge the frozen battery for the risk of explosion. Even if the battery has been unfrozen, battery acid may still overflow, resulting in corrosion damage. The frozen battery must be replaced.**

Turn off the ignition switch and all electrical appliances before charging.

If the vehicle has been stored for an extended period of time, and can not be started due to battery undercharge (general terminal voltage $\leq 12V$), the battery must be removed from the vehicle

Maintenance and Service

and charged with ground equipment (operating in accordance with the charging device manufacturer's instructions).

When charging with a low current (such as a small charging device) , generally it is not required to remove the battery connecting cables. But you must pay attention to the instructions given by the charging equipment manufacturer.

Before the quick charge, that is, before the high current charge, you must remove two connecting cables.

Note: Please pay attention to the warnings & instructions for battery before working on it. When charging, the power supply of charging device can be switched on only after the charging device electrode chuck clipped to the battery electrode as specified. After charging, first turn off the charging device, unplug the power cord, and then remove the electrode chuck of charging device from the battery.

Caution

- Keep children away from the battery, battery acid and charging devices.
- The battery can only be charged in an ventilated space. Smoking, open flame and electrical sparks are prohibited, because explosive mixed gas will be produced during battery charging!
- To protect your eyes and face, please stay away from the battery.
- If the acid splashes into eyes or on skins, rinse with clean water for a few minutes and go to see a doctor immediately.
- Battery fast charging is dangerous and should be performed by Service Dealer, because it requires specialized charging equipment and knowledge.
- Replace the frozen or unfrozen battery. Cracking may occur on the battery case because of freezing. Battery acid may leak and damage the vehicle.

Battery removal

Turn off the ignition switch and all electrical appliance before removing the battery.

To remove the battery, you should first remove the negative cable, next the positive cable, and then remove bolts on the battery retaining bracket , finally remove the battery.

Maintenance and Service

Battery replacement

Battery installed on your vehicle is designed according to appropriate mounting position. If the battery is to be replaced, the new battery should have the same voltage (12V), structure form and safety mark as those of the original one. The current intensity and capacity should be in line with that of the original battery. Service Dealer can provide genuine battery.

Please note that the ignition switch and the electrical appliance have been turned off when installing the battery.



In regard of the old battery disposal, it is better to have the battery replaced by Service Dealer. In addition, the battery contains sulfuric acid and lead, so it absolutely can't be treated as household waste.

Battery installation

Turn off the ignition switch and all electrical appliance before removing the battery.

Place the battery in the mounting position and secure it with battery bracket.

Secure the positive cable then the negative one, then energize the battery.

Caution

To avoid battery discharge, please turn off the ignition switch when leaving the vehicle.

Tires



It is very dangerous to use nonconforming or damaged tires! Do not drive the vehicle if you find a tire or tires are excessively worn, damaged or have incorrect inflating pressure.

Regularly check the tire and its sidewall for any sign of distortion (boss), cut or wear. Remove gravel and other sharp objects with an appropriate blunt. They may pierce tires if you ignoring them.

Tire pressures



If you drive the vehicle in the case of wrong tire inflation, it may affect the stability of the vehicle, increase the rolling resistance, result in accelerated tire wear, and may permanently damage the tire layer.

Remember the provisions on tire wear and inflation. The driver is responsible for ensuring that tires conform to these requirements.

Please check the tire pressure (including spare tire) every week and adjust the tire pressure as necessary according to the "Tire pressure mark" on the front side door frame. This manual describes the correct pressure of tire in cold state. Refer to "Wheels and Tires" in the General Technical Parameters section.

Maintenance and Service

The spare tire should maintain the recommended maximum pressure and make adjustments before use. An accurate tire pressure gauge should be used to check the air pressure when the tire is cold, instead making an impairment calculation when the tire is hot, since the pressure of hot tire will be higher than the normal pressure due to the temperature. The valve cap must be mounted to prevent dust from entering into the valve.

After a period of time, natural air pressure drop may occur on tires; if abnormal pressure drop exists, you should immediately identify the cause and correct it.

Note: *Specified pressure applies to a cold tire, while the pressure of hot tire should be higher.*

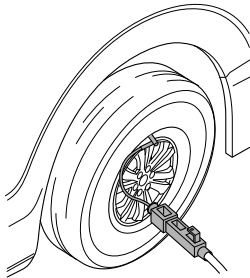

Wear indicators

There are wear indicators in the treads of the original tire. When the tire wears to the degree that the tread is 1.6 mm left, the tread of the entire cross-surface will show wear indicators.

If you see any part of the wear indicator, replace the tire immediately. Note, however, that the safety and performance of the tire will be impaired even before the wear indicator is reached. For instance, a seriously worn tire can increase the risk of slipping.

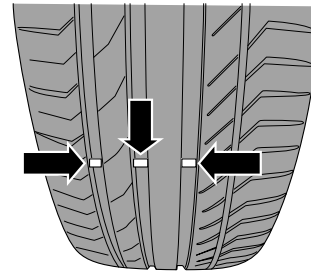

Maintenance and Service

Tire check and rotation

To ensure even tire wear, it is recommended to have the tire check every 5,000 kilometers. When uneven tire wear is found, the tire position should be changed. After the tire rotation, check the tires for proper dynamic balance.

During the tire rotation, check for uneven tire wear and damage. Abnormal tire wear is often the result of incorrect tire pressure, wheel misalignment, poor wheel dynamic balance, emergency braking or emergency turn. Check the tread or side of the tire for bruise or bulge; if one of the conditions is found, or the fabric or cord is seen, replace the tire. After the tire rotation, adjust the inflation pressure of the front and rear tires as indicated by the tire pressure label on the vehicle and check the tightening torque of the wheel nuts.

Tire Rotation Patterns for Vehicles Equipped with Full-size Spare Tires

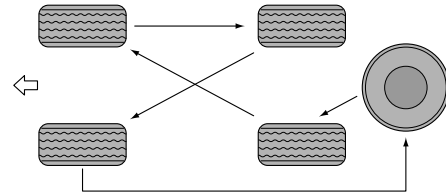

Tire Rotation Patterns for Vehicles Equipped with Small-size Spare Tires

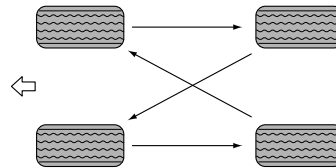

Other Maintenance

Vehicle wash



When driving the vehicle for the first time after washing, gently depress the brake pedal several times to remove the water on the brake disc.

Wash the tires carefully. Don't use high-pressure nozzle because it may damage the tire. If any damage is found, please replace the tire.

Don't wash the front part of inner vehicle (adjacent to instrument panel) to avoid unnecessary damage to relevant parts.

The following points contribute to the vehicle value preservation:

- Wash the vehicle with cold or warm water. Hot water may impair vehicle paint in extremely cold weather.
- Don't wash the vehicle under intensive direct sunlight in hot weather.
- Use vehicle-specific cleaner to remove grease and tar spots on the vehicle body. When the body is wet, wash it with a soft sponge and an appropriate amount of water. Rinse thoroughly and wipe dry with a chamois leather.
- When cleaning the vehicle with a hose, it is prohibited to spray the water directly to the window, the door, or the brake through the gap of the wheel.

- After cleaning, you should check whether there is damage or stone chips on the paint. If necessary, repair the paint. Use polishing wax occasionally to protect the paint surface.
- Keep the sprayer moving when using a high pressure cleaning device. Do not directly wash the engine, radiator, door gap, seals, electrical components or components connected to it.

Note: Please timely remove the substances on the surface of the paint which seem harmless but in fact corrosive, such as bird droppings, resin, insect wreckage, tar spots, road salt and industrial dust. If not removing them timely, stain and damage may be permanently left.

Caution

It is prohibited to open the engine hood and directly rinse the engine compartment, as this may cause short circuits of electrical components in the engine compartment. Don't use steam to clean the underbody, wheelhouse or transmission portion, as this will damage the protective wax layer.

Engine carbon deposit cleaning

In view of the quality of domestic fuel products, it is recommended to use the fuel system carbon deposit cleaner certified by our company every 5,000 km to 10,000 km regularly. Please consult our Service Dealer for details.

Underbody corrosion protection

The underbody of your vehicle has been treated with corrosion protection. Check the corrosion protection of vehicle underbody regularly.

You can use a sprayer to clean the dust or mud accumulated on the underbody. Especially in winter, when salt is used on icy and snowy road.

Seat and interior trim

Remove dust accumulated on the fibers with a vacuum cleaner or a soft brush frequently. Wipe the interior trim with clean cloth frequently. Ordinary interior dust, spots or stains can be removed using a special cleaner. Clean the leather trim with specialized cleaner.

Door seals

To prevent rubber door seals from freezing in cold weather, use rubber care products or silicone sprays to protect it.

Windows

Frequently clean the windshield with glass cleaner.

The headlamp lens is a transparent plastic material. Please clean the windows with high-quality cleaner or neutral detergent. Do not use friction agent or chemical solvents.

General Technical Parameters

264 Main Vehicle Dimension
Parameters

265 Complete Vehicle Mass
Parameters

267 Complete Vehicle
Performance Parameters

268 Main Engine Parameters

269 Chassis Technical Parameters

270 Recommended Fluids

272 Wheels and Tires

273 Wheel Alignment Parameters

General Technical Parameters

Main Vehicle Dimension Parameters

Product Model	SV9A-1300	SV9A-1310	SV9A-1100	SV9A-1110
Driving type	4X2, Front-engine Rear-drive	4X4, Front-engine 4WD	4X2, Front-engine Rear-drive	4X4, Front-engine 4WD
Length of overall dimension, mm	5005			
Width of overall dimension, mm	1932			
Height of overall dimension, mm	1875			
Wheel base, mm	2950			
Front/Rear suspension, mm	935/1120			
Front wheel track, mm	1600			
Rear wheel track, mm	1620			
Minimum turning circle diameter, m	12			

General Technical Parameters

Complete Vehicle Mass Parameters

Product Model	SV9A-1300	SV9A-1310
Engine Model	20L4E	20L4E
Total Mass, kg	2800, 2900	2960
Curb weight, kg	2130, 2210	2330
Axle load (Front/rear axle load under total mass), kg	1140/1660 1180/1720	1270/1690
Axle load (Front/rear axle load under curb weight), kg	1060/1070 1100/1110	1180/1150
Number of Seats	7	7

General Technical Parameters

Product Model	SV9A-1100					
Engine Model	SC20M163Q5A			SC20M218Q5A		
Total Mass, kg	2900, 3000	2900, 3000	2900, 3000	2900, 3000	2900, 3000	2900, 3000
Curb weight, kg	2200, 2265	2230, 2310	2240, 2320	2210, 2280	2245, 2320	2255, 2330
Axle load (Front/rear axle load under total mass), kg	1330/1570 1320/1680	1280/1620 1320/1680	1270/1630 1320/1680	1340/1560 1380/1620	1310/1590 1350/1650	1280/1620 1340/1660
Axle load (Front/rear axle load under curb weight), kg	1160/1040 1180/1085	1160/1070 1180/1130	1150/1090 1180/1140	1170/1040 1190/1090	1170/1075 1180/1140	1160/1095 1190/1140
Number of Seats	5	6	7	5	6	7

Product Model	SV9A-1110		
Engine Model	SC20M218Q5A		
Total Mass, kg	3100	3100	3100
Curb weight, kg	2370	2410	2420
Axle load (Front/rear axle load under total mass), kg	1410/1690	1410/1690	1410/1690
Axle load (Front/rear axle load under curb weight), kg	1230/1140	1250/1160	1260/1160
Number of Seats	5	6	7

General Technical Parameters

Complete Vehicle Performance Parameters

Product Model	SV9A-1300	SV9A-1310	SV9A-1100	SV9A-1100	SV9A-1110
Engine Model	20L4E	20L4E	SC20M163Q5A	SC20M218Q5A	SC20M218Q5A
Maximum design speed, km/hour	185	185	175	185	180
Maximum gradability, %	45 (2WD)	55 (4WD)	45 (2WD)	45 (2WD)	55 (4WD)
Emission level reached when the complete vehicle leaving factory	Euro V	Euro V	Euro V	Euro V	Euro V

General Technical Parameters

Main Engine Parameters

Engine Model	20L4E	SC20M163Q5A	SC20M218Q5A
Type	In-line 4-cylinder, water-cooled, turbochargd intercooled, in-cylinder central direct injection gasoline engine	In-line 4-cylinder, water-cooled, turbochargd , intercooled, direct injection, diesel engine	In-line 4-cylinder, water-cooled, turbochargd , intercooled, direct injection, diesel engine
Displacement, L	1.995	1.996	1.996
Number of Cylinder	4	4	4
Cylinder Bore, mm	88	83	83
Stroke, mm	82	92	92
Volume Compression Ratio	10:1	15.9:1	15.9:1
Engine speed at rated power, rev/min	5300	4000	4000
Maximum net power, KW	160	118.5	158.5
Maximum torque, Nm	350	375	480
Engine speed at maximum torque, rev/min	2500 ~ 3500	1500 ~ 2400	1500 ~ 2400
Idle speed, rev/min	750±30	750±25	750±25
Fuel Type and Grade	Gasoline of 92# or above, conforming to Euro V and above standards	Diesel, conforming to Euro V and above standards	Diesel, conforming to Euro V and above standards
Fuel tank capacity, L	75	75	75

General Technical Parameters

Chassis Technical Parameters

Item	Parameters
Front Suspension Structure	Double wishbone independent suspension
Rear Suspension Structure	Five-link non-independent suspension
Dynamic Balance Requirements of Steel Wheels	Residual dynamic unbalance allowable at one side: below 10 grams Maximum balance block applied at outer side is 60 grams, and the total of two sides shall not exceed 120 grams
Dynamic Balance Requirements of Aluminum Wheels	Residual dynamic unbalance allowable at one side: below 8 grams Maximum balance block applied at one side is 80 grams, and the total of two sides shall not exceed 160 grams
Rational Range of Brake Pedal Free Stroke	within 10 mm
Rational Use Range of Brake Friction Pair	Friction material thickness is greater than 2 mm

General Technical Parameters

Recommended Fluids





Item	Grade	Capacity
20L4E Engine lubricating oil, L	ACEA C3 5W-30	5.6
SC20M163Q5A Engine lubricating oil, L	SAE 5W-30 ACEA C3	4.7
SC20M218Q5A Engine lubricating oil, L	SAE 5W-30(PRO) ACEA C3	4.7
20L4E Engine coolant, L	D-35(-35°C)	11.5
SC20M163Q5A, SC20M218Q5A Engine coolant, L	D-35(-35°C)	13.5
SC20M218Q5A Engine Water-air intercooler(open system) coolant, L	D-35(-35°C)	3.6
SC20M218Q5A Engine Water-air intercooler(closed system) coolant, L	D-35(-35°C)	4.0
6th speed manual transmission oil (SAGW), L	Fuchs MTF SAE 75W-85, Castrol BOT581, Shell MTF GJ, SK MTF 75W-85 201005	2.5(±0.1)
6th speed manual transmission oil (DYMOS), L	Fuchs MTF SAE 75W-85, Castrol BOT581, Shell MTF GJ, SK MTF 75W-85 201005	2.5
6th speed automatic transmission oil, L	petro-Canada Dexron VI	10.2
8th speed automatic transmission oil, L	Shell L12108	8.77
Brake fluid, L	Laike 901-4 DOT 4	0.66
Washer fluid, L	General low freezing point detergent	2.2
Air conditioning refrigerant, g	R134a	900 ± 30 (with rear internal A/C) 620 ± 30 (without rear internal A/C, dual A/C)
Front axle lubricant, L	TEMPO GL-5 80W-90	0.9

General Technical Parameters

Item	Grade	Capacity
Rear axle lubricant, L	TEMPO GL-5 80W-90	1.74
Transfer case lubricant (real-time 4WD system), L	Mobil LT	1.5
Transfer case lubricant (all terrain 4WD system of gasoline engine model), L	Mobil LT	1.5
Transfer case lubricant (all terrain 4WD system of diesel engine model), L	MERCON LV	1.5
Transfer case lubricant (part-time 4WD system), L	ATF-DEXRON III	1.5

General Technical Parameters

Wheels and Tires

Item			Parameters			
Wheel Specification			7Jx17	7.5Jx18	7.5Jx19	8.5Jx21
Tire specification			255/65R17	255/60R18	255/55R19	265/45R21
Tire Pressure (cold)	Front wheels	1-3 	220kPa/2.2bar/32psi	220kPa/2.2bar/32psi	220kPa/2.2bar/32psi	230kPa/2.3bar/33psi
		4-8 	220kPa/2.2bar/32psi	220kPa/2.2bar/32psi	220kPa/2.2bar/32psi	230kPa/2.3bar/33psi
	Rear wheels	1-3 	220kPa/2.2bar/32psi	220kPa/2.2bar/32psi	220kPa/2.2bar/32psi	230kPa/2.3bar/33psi
		4-8 	270kPa/2.7bar/39psi	270kPa/2.7bar/39psi	270kPa/2.7bar/39psi	280kPa/2.8bar/41psi
Small Size Spare Tire Specification			245/65R17	245/65R17	245/65R17	245/65R17
Small Size Spare Tire Pressure (cold state)			290kPa/2.9bar/42psi	290kPa/2.9bar/42psi	290kPa/2.9bar/42psi	290kPa/2.9bar/42psi
Full Size Spare Tire Specification			255/65R17	255/60R18	255/55R19	265/45R21
Full Size Spare Tire Pressure (cold state)			270kPa/2.7bar/39psi	270kPa/2.7bar/39psi	270kPa/2.7bar/39psi	280kPa/2.8bar/41psi

General Technical Parameters

Wheel Alignment Parameters

Item		Parameters
Front wheels	Toe-in angle	$0 \pm 0.15^\circ$ Total toe-in $\leq 0.15^\circ$
	Camber angle	$0 \pm 0.5^\circ$ Difference value between left and right $\leq 0.5^\circ$
	Kingpin caster	$3.6 \pm 0.5^\circ$ Difference value between left and right $\leq 0.5^\circ$
Rear wheels	Toe-in angle	$0^\circ \pm 0.25^\circ$
	Camber angle	$0^\circ \pm 0.5^\circ$
	Thrust Angle	$0^\circ \pm 0.25^\circ$