Thank you for choosing SAIC MAXUS Automotive Co.,Ltd. May our products and services bring fresh joy to your life!

Please take time to read and understand this Handbook and other publications supplied with it. Thus you can familiarize yourself with the vehicle and enjoy a driving experience with comfort, safety as well as economy.

This Driver's Handbook will provide you with the information necessary for getting familiar with your vehicle, including how to drive the vehicle, how to carry out routine maintenance checks, and what to do in an emergency.

This Handbook contains the latest information upon the time of printing and all modifications, interpretations and explanations should be reserved by the company. Based on the consideration that the products will be upgraded or in any other way(s) modified constantly, the company reserves the right to apply these changes mentioned here before without notice when the Handbook has been hereby printed and published and will accept no liability.

This Handbook is an indispensable part of the vehicle. If you want to sell the vehicle, please remember to provide the new owner with this Handbook.

Special Announcement

Driver's Handbook and Warranty & Service Handbook specify the agreement between the company and the user on establishment and termination of rights and obligations concerning the quality warranty and after-sales service of product. Please be sure to read the Driver's Handbook and Warranty & Service Handbook carefully before using the product. If any damage is caused by misuse, neglect, incorrect operation or unauthorized refit, the user will have no right of claim, and any warranty request will be refused by SAIC MAXUS Automotive Co.,Ltd Service Dealer(hereinafter referred to as "Service Dealer").

Unauthorized re-production of this Handbook, whether electrically, physically or in any other way, and/or storing the Handbook in any inquiry system of any form or type shall not be permitted.

Wish you a pleasant driving!

SAIC MAXUS Automotive Co.,Ltd. Address: #2500, Jun Gong Road, Yang Pu District, Shanghai Postcode: 200438

SAIC MAXUS Automotive Co.,Ltd reserves the final right to interpret this Handbook

Contents

Perface	1	Power windows	19
Introduction	1	Seats	21
About this handbook	1	Driver's seat adjustment	21
Precautions	2	Front passenger seat adjustment.....	23
Dangerous substances.....	2	Rear occupant seat adjustment.....	23
Children/Animals	2	Headrest.....	25
Personal safety.....	2	Passenger restraint system	25
Vehicle identification	3	Sitting correctly.....	25
Vehicle identification number (VIN)	3	Seat belts	26
Type and number of drive motor	3	Airbag(s).....	29
VIN plate.....	4	Child restraints (not supplied with the vehicle).....	38
Instructions for using electric vehicle	5	Instruments and controls	40
Ambient temperature for using vehicle.....	5	Instrument cluster	41
Driving range	5	Drive motor power percentage gauge	41
Equalizing charge.....	6	High-Voltage battery pack electric quantity	41
Recycle instructions for high-voltage battery packs	6	Speedometer.....	42
High voltage system	7	Information center	42
Instructions when accident occurs	8	Alarm messages.....	45
1 Before You Drive	9	Service interface reminders.....	46
Keys	10	Warning lights and indicators	47
Ordinary key	10	Direction indicator.....	47
Remote key	11	Headlight high beam indicator.....	47
Extension/retraction of mechanical key portion.....	11	Rear fog light indicator	47
Replace the battery in a remote key.....	12	Position light indicator	47
Door locks	14	Airbag warning light.....	47
To protect your vehicle against theft.....	14	Seat belt warning light.....	47
Central door lock system.....	15	Brake system warning light	48
Tailgate.....	18	ABS (Anti-lock Braking System) warning light.....	48
Windows	19	EBD (Electronic Brake Distribution) warning light	49

Contents

ESC (Electronic Stability Control) indicator	49	Front vents	64
ESC (Electronic Stability Control) OFF indicator	49	Rear vent	65
HDC (Hill Descent Control) indicator	49	Electronic A/C control panel	66
EPS (Electric Power Steering) system MIL	49	Recommendation for A/C operation	68
Drive motor theft deterrent warning light	50	Rearview mirrors	68
Body theft deterrent warning light	50	Exterior rearview mirrors	68
Battery no-charge warning light	50	Interior rearview mirror	69
Drive motor overheat warning light	50	Interior equipment	70
Power system failure warning light	50	Front roof vanity light	70
High-voltage battery pack low warning light	50	Rear roof vanity light	71
High-voltage battery pack failure warning light	51	On-board inverter	71
Charging connection indicator	51	12V power outlet	72
Charging status indicator	51	USB port	74
Ready indicator	51	Cup holders	74
Insulation failure warning light	52	Storage box	75
Limited power indicator	52	Glove box	75
Trailer indicator	52	Sun visor and vanity mirror	76
Instrument panel switch	52	MP5+Radio	76
Headlamp leveling switch	52	Precautions before use	76
Hazard warning light switch	53	Entertainment system control switch	77
Entertainment system control switch	54	Introduction and operation of main interface functions	78
Floor console switch	54	2 Starting and Driving	79
Switches on steering column and steering wheel	55	Before starting and driving	80
Ignition switch and steering lock	56	Ignition switch	80
Combination lamp control & direction indicator lamp stalk switch	56	Key start	80
Wiper & washer stalk switch	59	Keyless start	81
Volume control, mute, audio source and Bluetooth phone switch	61	PEPS system	83
Steering wheel adjustment	62	Keyless unlocking	83
Horn	63	Keyless locking	83
Heating, ventilation and air conditioning	63		

Contents

Keyless start.....	84	Parking sensor	110
Backup starting.....	84	Parking camera	112
Emergency flameout	85	Tires	113
Starting/Stopping.....	85	Winter tires	113
Starting	85	Anti-skid chain	115
Stopping	85	Loading	115
Driving	86	Load carrying.....	116
Gear shifting	87	Load restraint	116
Charging requirement.....	88	Hazardous loads	117
Requirements for charging equipment	89	Roof Rack and Load Device.....	118
Safety instructions for charging with residential electricity	89	Trailer towing	119
Requirements for charging environment	91	Instructions of trailer towing.....	119
Influence of charging operation on special personnel	91	Trailer control module.....	121
Charging mode.....	92	Recommended towing weight	122
Fast charging.....	93	Installation of trailer device.....	122
Slow charging.....	95	Maintenance.....	123
Charging information	100	3 Emergency Troubleshooting	125
Equalizing charge.....	100	Hazard warning light.....	126
Charging time	101	Warning triangle	126
Acoustic vehicle alerting system (AVAS)	102	Self tire repair	127
Acoustic vehicle alerting system (AVAS) sound effect	102	Precautions	127
Electric power steering unit.....	103	Tire repair kit	128
Brake system	103	Usage.....	129
Service brake	103	Towing a vehicle	134
ABS (Anti-lock Braking System).....	105	Towing hitch.....	134
ESC (Electronic Stability Control).....	106	Jump start.....	135
Manual parking brake.....	109	Battery disconnection	135
Warning Light	110	Jump start.....	136
Parking assist system	110	Fuse replacement	137

Contents

Driver compartment fuse box	137	Maintenance and service	157
Front compartment fuse box	140	Seat belts	158
Battery fuse box	144	Inspection	158
Fuse replacement.....	144	Maintenance and service	158
Bulb replacement.....	145	Battery	159
Bulb specification	146	Duration of storing the vehicle.....	160
Bulb replacement	146	Operating in winter	161
4 Maintenance and Service.....	149	Charging the battery with ground equipment	161
 Regular maintenance.....	150	Removing the battery	162
 Owner's check	150	Replacing the battery	163
Daily checks	150	Installing the battery	163
Weekly checks or check before a long journey	151	High-voltage battery pack.....	164
Harsh conditions.....	151	Instructions and restricted conditions	164
 Front compartment.....	151	Tires	166
 Front compartment hood.....	152	Tire pressure	166
Open front compartment hood	152	Wear indicator	167
Close front compartment hood	152	Other maintenance	168
 Coolant	153	Vehicle cleaning	168
Check and refill.....	153	Anti-corrosion of underbody	169
 Brake fluid.....	154	Seat and trim	169
Check and refill.....	155	Door seal	169
 Washer fluid.....	155	Window glass	169
Check and refill.....	155	5 General Technical Parameters	171
 Washer nozzle.....	156	 Major vehicle dimension parameters	172
Adjustment and cleaning.....	156	 Vehicle weight parameters	173
 Wiper blades	156	 Dynamic performance index.....	174
Check	156	 Major parameters of drive motor	175
Replacement	157	 Chassis technical parameters	176

Contents

Recommended fluids.....	177
Wheel and tire.....	178
Wheel alignment parameters.....	179

<https://www.automotive-manuals.net>

Preface

Introduction

About this handbook

This Handbook applies to T90 series of pure electric multi-purpose truck.

Caution

The information contained in this Handbook is designed to cover more than one model option and variant, and therefore some of the items mentioned here may not apply to your vehicle.

The applicable executive enterprise standard is Q31/0110000019C032.

The drawings contained in this Handbook are illustrations for references only.

Indicative information

Warning



This symbol indicates that: In order to avoid the possibility of personal injury or injury to others, relevant procedures must be followed strictly and precisely.

Caution

Caution

Relevant procedures must be followed to avoid the possibility of vehicle damage.

Note

Note: This is suggestive description which is useful for you.

Environmental protection



Everyone is obliged to protect the environment. This symbol intends to remind you to pay attention to environmental protection.

Arrows



It represents the described object.



It represents its direction of motion.

See

The contents are referred by the "Section" title.

Precautions

Dangerous substances

 Many liquids and other substances used in motor vehicles are poisonous and should under no circumstances be consumed and should, so far as possible, be kept away from open wounds. These substances among others include battery acid, coolant, brake fluid, washer fluid, lubricants, refrigerant and various adhesives. Always read carefully the instructions printed on the labels or stamped on components and obey them implicitly. These instructions are for the sake of your health and personal safety. Please treat them with prudence.

For your safety, observe instructions contained in this Handbook.

Children/Animals

 Accidents and injury may be caused by unsupervised children or animals operating controls and switches fitted to your vehicle, or playing with equipment or goods being transported in it.

In order to prevent the accident or personal injury caused by a child or animal, do not leave the child or animal in the vehicle without adult supervision. Also they can become suffocated in hot weather conditions.

Personal safety

 Seat belts are fitted to all seats in your vehicle to reduce the possibility of personal injury in the event of an accident. It is required that all occupants wear a seat belt. In addition, a **Supplementary Restraint System (SRS)** is fitted for additional protection of the driver and front occupants, comprising air bags and seat belts.

See "Occupant restraint system" in Before You Drive section. Misuse of an air bag can result in injury.

Vehicle identification

When communicating with our Service Dealer, you should provide the vehicle identification number (VIN).

Vehicle identification number (VIN)

Vehicle identification number (VIN) on the vehicle :

- On the right front girder of vehicle (seal position).
- On the VIN plate on the left B pillar.
- On the windshield lower cross member at the right lower corner of the windshield through where the VIN can be seen easily.

This vehicle is equipped with an OBD data link connector, which is located at the lower side of the instrument cluster. You can contact Our Service Dealer to read VIN information from the electronic control unit of the vehicle with the special device from our company.

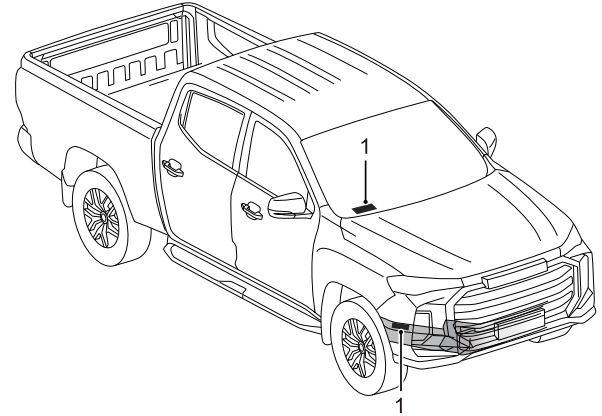

1 Vehicle identification number (VIN)

Type and number of drive motor

The type and number of the drive motor are engraved on the housing of the drive motor.

Preface

VIN plate

VIN plate may contain the following information, please refer to the actual vehicle.

- The manufacture's company name
- The whole vehicle type-approval number
- VIN
- The technically permissible maximum laden mass
- The technically permissible maximum mass of the towing
- The technically permissible maximum mass on each axle listed in order from front to rear

Location of VIN plate

The VIN plate (1) is located at the front of the left B pillar.

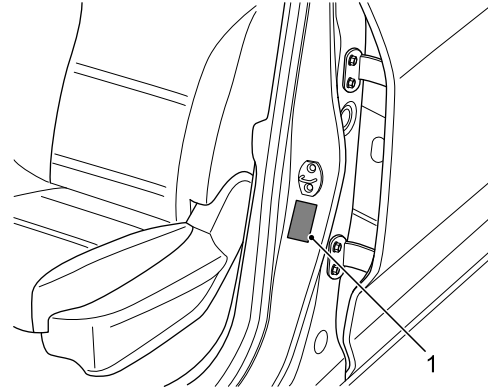

Instructions for using electric vehicle

Ambient temperature for using vehicle

The working performance of high-voltage battery pack of vehicle power system is related to the ambient temperature, therefore it is recommended that the vehicle should be used within the temperature range of $-15^{\circ}\text{C} \sim 45^{\circ}\text{C}$, to ensure that the vehicle is at the best working state, and meanwhile extend the service life of high-voltage battery pack. High or low temperatures can affect the performance of the high-voltage battery pack and the vehicle.

Driving range

Driving range depends on the battery capacity available to the vehicle, the age of the vehicle (service life of the current battery), weather, temperature, road condition, driving habits, etc. Please note:

- Driving range is related to the depth of discharge (DOD). To avoid high DOD affecting the performance of high-voltage battery pack, it is recommended that you recharge the battery in time upon seeing the illuminated "high-voltage battery pack low battery warning light" on the instrument cluster.
- The actual driving range decreases with the increase of the age of the vehicle.
- The use of air conditioning will reduce the driving range.
- The driving range varies with the speed.

- When the vehicle is used at low temperatures, the driving range will be reduced due to temperature characteristics of the battery.
- In the case of extreme temperatures and low battery, weak acceleration or lack of power may occur due to battery characteristics. Driving range can be increased by:
 - Having the vehicle maintained regularly;
 - Maintaining proper tire pressures;
 - Using the vehicle as few as possible at high or cold temperatures.
 - Charging the battery at once after the vehicle is stopped in winter;
 - Lightening the load by removing unnecessary items;
 - Turning off high-power electrical equipment such as the air conditioning, or adjusting the heating or cooling base temperature as necessary to minimize the energy consumed by high-power electrical equipment and increase the driving range.
 - Closing the windows under the condition that the vehicle is running at a high speed, so as to reduce air resistance and power consumption.
 - Keeping a steady speed.
 - Depressing the accelerator pedal as lightly as possible while accelerating.

Preface

- Releasing the accelerator pedal and not applying the brakes or depressing the brake pedal lightly during deceleration to allow the energy regeneration system to increase the driving range as much as possible.

Equalizing charge

To extend its service life, the high-voltage battery pack must be maintained regularly by means of an equalizing charge. It is recommended using the vehicle at least once a month. It is also recommended conducting over-10h slow charging for the vehicle every month to extend the service life of high-voltage battery pack.

Recycle instructions for high-voltage battery packs

The high-voltage battery pack mounted at chassis position contains many lithium cells. Arbitrary disposal may cause pollution and harm to the environment. It is forbidden to dismantle and discard without approval. It will be disposed of by professional institution. Please refer to the following information or requirements for recycling. Details about recycling and disposal of high-voltage battery pack can be obtained through consulting our Service Dealer.

- Personnel requirements: Dismantling must be done by qualified professionals.
- High voltage safety: Insulation protection measures must be adopted for internal high-voltage components such as lithium

batteries and high-voltage harnesses before uncovering or dismantling.

- Transportation: High-voltage battery packs are classified as Class 9 dangerous goods and must be transported by vehicles qualified for the transportation of Class 9 dangerous goods.
- Storage: The removed high-voltage battery pack should be stored in a dry, room temperature environment, away from inflammables, heat sources, water sources and other hazard sources.
- Internal composition: The high-voltage battery pack consists of a series of components such as lithium cells (batteries), circuit boards, electric wires and metal shells.

It is recommended that you hand over the used high-voltage battery pack due to vehicle scrapping or other reasons to the recycling service outlet designated by our company for disposal. Details about servicing, recycling and disposal of high-voltage battery pack can be obtained through consulting our Service Dealer.

Note: In case of environmental pollution or safety accidents caused by handing over the used high-voltage battery pack to another unit or individual, or removing and dismantling the high-voltage battery pack without permission, the owner of the high-voltage battery pack shall bear the corresponding responsibilities.

High voltage system

⚠ High voltage system on vehicle includes AC and DC high voltage power (can reach over 410V). High voltage power is very dangerous and may cause serious injury such as burns, electric shock and even death.

- It is forbidden to contact high voltage cables and its connectors to avoid personal injury.
- Parts with orange labels are parts of high voltage system. These parts are equipped with warning label of high voltage system. Requirements on warning label of high voltage system must be abided by.
- Non-professional maintenance personnel are prohibited from contacting, dismantling or installing any component of high voltage system without permission.
- Untrained personnel are prohibited from contacting or operating the manual service switch on the high-voltage battery pack.

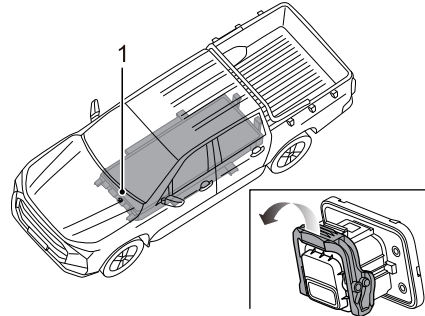

1 Manual service switch

Instructions when accident occurs



- Keep the vehicle in N gear, and turn off the Ignition switch.
- If cables on the vehicle are exposed or damaged, it is forbidden to contact any cable to prevent electric shock.
- If fire disaster occurs, personnel shall immediately leave the vehicle and use ammonium carbonate salt fire extinguisher to put out the fire or use lots of water to put out the fire. It is strictly prohibited that any person contacts or enters ignited vehicle during the rescue period. After fire has been put out, continuous observation is required. Professional personnel will remove the vehicle to spacious area after confirming power battery does not have abnormal sound and smoke. Professional personnel will confirm battery state before vehicle transfer.
- If vehicle is collided, vehicle cannot be re-started. In addition, the manual service switch will be disconnected when rescuing.
- When vehicle is completely or partially immersed into water, personnel will turn off the vehicle and timely escape. The manual service switch will be disconnected before transporting vehicle that has been refloated. If there is not bubble or abnormal sound when refloating, refloating operation can

be conducted; if there is bubble or abnormal sound, operation can be conducted when there is not bubble or abnormal sound.

- After accident has been disposed of, please contact our Service Dealer.

Before You Drive

- 10 Keys
 - 14 Door locks
 - 19 Windows
 - 21 Seats
 - 25 Passenger restraint system
 - 40 Instruments and controls
 - 41 Instrument cluster
 - 42 Information center
 - 47 Warning lights and indicators
 - 52 Instrument panel switch
 - 55 Switches on steering column and steering wheel
 - 62 Steering wheel adjustment
 - 63 Horn
 - 63 Heating, ventilation and air conditioning
 - 68 Rearview mirrors
 - 70 Interior equipment
 - 76 MP5+Radio
-

Before You Drive

Keys

The vehicle is equipped with 1 ordinary key and 1 remote key or 2 remote keys with passive entry passive start system (hereinafter referred to as PEPS).

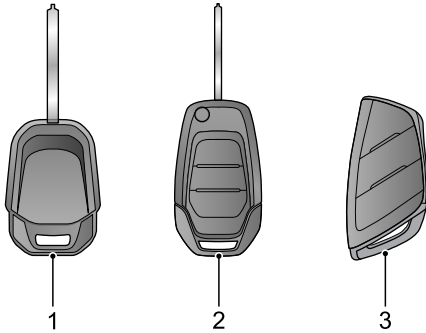

- 1 Ordinary key
- 2 Remote key
- 3 Remote key with PEPS

Note: *If a key is lost, you must provide the key number on the metal or plastic plate attached with the key, and the Our Service Dealer will provide the replacement. To ensure safety, you are recommended to keep the metal or plastic plate attached with key properly. For the sake of safety, the key has been electronically coded with the vehicle immobilizer system and can be used with the system in the*

matching way only. Special procedures shall be followed to manufacture a same key with the lost one. Any uncoded key cannot start the vehicle but can lock/unlock doors.

Ordinary key

The common key is mainly used for activating the vehicle immobilizer system and starting the system and also can be used for locking/unlocking the driver door and passenger doors. Use of an ordinary key in either of these doors (driver's door excluded) will lock/unlock that door only. For further information on the use of the ordinary key, see "Doors and locks" and "Ignition switch and steering lock" in this section.

Before You Drive

Remote key

Remote key is a control component of automobile central locking system. It can be used for locking/unlocking all doors; the car locating button on the remote key also can help you locate your car.

Note: The remote key has been electronically coded with the locking/unlocking system and can be used with the system in the matching way only. Special procedures shall be followed to manufacture a same remote key with the lost one. Our Service Dealer will be pleased to assist you. For further information on the use of the remote key, see "Central door lock system" in this section.

Caution

The vehicle immobilizer system can accept 8 coded keys at most (including common keys and remote keys). The vehicle immobilizer system can accept 4 coded keys at most (for remote keys with PEPS function).

Extension/retraction of mechanical key portion

Mechanical Key Portion of Remote Key can be extended or retracted, hereinafter referred to as mechanical key portion.

Mechanical key portion

Press the release button on the remote key, and the mechanical key portion will extend from the key body.

To retract the mechanical key portion, press the release button on the remote key meanwhile rotate the mechanical key portion into the key body.

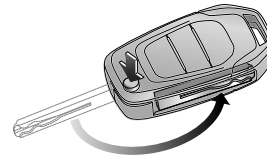
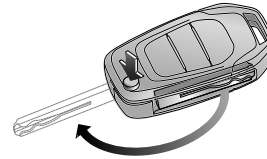

Before You Drive

Mechanical key portion of a remote key with PEPS

Press the release button on the remote key with PEPS, and pull the mechanical key portion from the key body.

To retract the mechanical key portion, directly insert it into the body of remote key with PEPS.

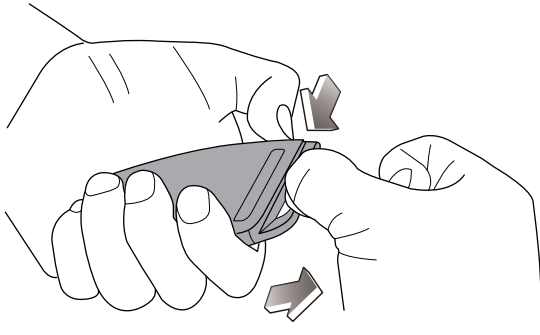

Replace the battery in a remote key

! Batteries may present the risk of fire, explosion and burning. Never charge the battery. Properly dispose the used battery. Keep the battery out of reach of children.

! **WARNING:** Do not ingest the battery, chemical Burn Hazard.

This product contains coin/button cell battery. If the coin/button cell battery is swallowed, it can cause severe internal burns in just 2 hours and can lead to death. Keep new and used batteries away from children. If the battery compartment does not close securely, stop using the product and keep it away from children. If you think batteries might have been swallowed or placed inside any part of the body, seek immediate medical attention.

WARNING



Before You Drive

To replace the battery, following procedures must be observed:

Replace the battery in a remote key

- 1 Extend the mechanical key portion;
- 2 Pry the battery cover from the key body (with a coin);
- 3 Remove the used battery and install a new one;

Note: It is recommended to use a CR2032 battery.

Caution

Pay attention to the positive and negative of battery.

- 4 Then install the battery cover onto the key body.

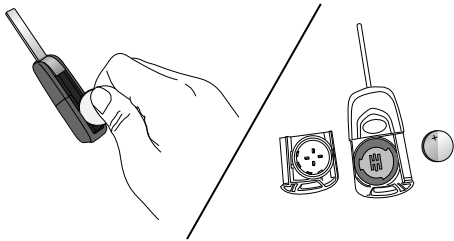

Replace the battery in the remote key with PEPS

- 1 Press the release button on the remote key with PEPS;
- 2 Pull the mechanical key portion out of the key body;
- 3 Pry off the upper and lower panels of the body; the circuit board may fall off from the upper panel assembly when prying off them, and reinstall them;

Caution

Do not damage the circuit board when prying off the upper and lower panels.

- 4 Remove the used battery from the lower panel assembly and install a new one;

Note: It is recommended to use a CR2032 battery.

Caution

Pay attention to the positive and negative of battery.

- 5 Refit the upper and lower panels of the battery body, and press their circumference to ensure they are clamped in place;

Caution

Do not ignore the waterproof shim and circuit board onto the upper panel of the key body.

- 6 Press the mechanical key portion into the key body.

Before You Drive

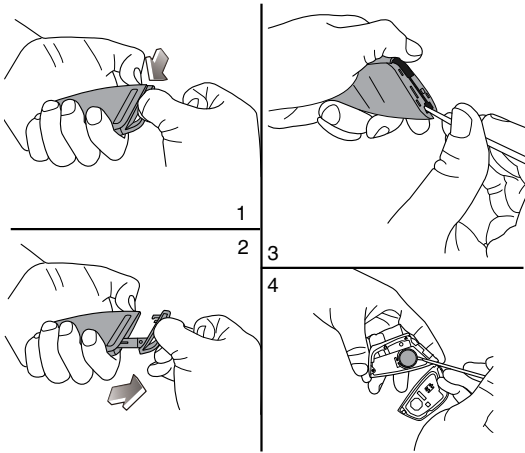

Caution

It is complicated to replace the battery in the remote key with PEPS. In order to prevent the key from being damaged due to misassembly or misoperation, you are recommended to have the battery replaced by Our Service Dealer.

Door locks

To protect your vehicle against theft

! If leaving the vehicle with passengers inside, even briefly, always carry the key around and turn off the ignition switch, particularly if children are left in the vehicle. Otherwise, they may start the vehicle or operate the electrical device, which may result in a risk of accident.

Close all windows before leaving the vehicle.

Ensure all doors are fully closed before locking them.

Lock/unlock

You may lock/unlock all doors from outside with the ordinary key, remote key, or the remote key with PEPS. All doors can be locked/unlocked from the inside using central lock switch. All doors can be automatically locked according to the vehicle speed. See "Central door lock system" in this section.

Note: *When all doors are successfully locked with the remote key, all turn signal lamps will flash once, and the horn will sound once to indicate successful locking.*

Note: *When all doors are successfully unlocked with the remote key, all turn signal lamps will flash twice to indicate successful unlocking.*

Before You Drive

Central door lock system

Using the ordinary key or mechanical key portion

All doors can be locked/unlocked by manually locking/unlocking the driver door using the ordinary key or mechanical key portion from the outside.

To lock, turn the ordinary key or mechanical key portion counterclockwise. To unlock, turn the ordinary key or mechanical key portion clockwise.

Using the remote key

The doors can be locked/unlocked through the central door lock system using the buttons on the remote key.

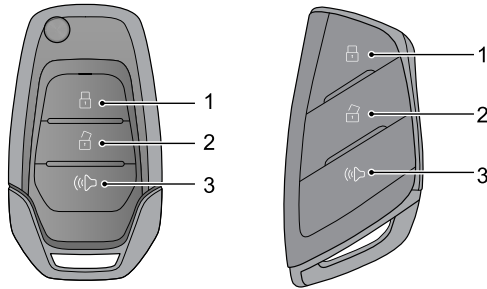

- 1 Central locking button
- 2 Central unlocking button
- 3 Car locator button

Note: All doors must be fully closed for the system to operate correctly.

Caution

For vehicles with PEPS system, when locking with the LOCK button on the remote key with PEPS, if there is other legal remote key with PEPS in the vehicle, then the latter key will be disabled, and the passive entry and one touch start feature will be lost. To activate it: close all doors, operate the unlock button on the remote key with PEPS in a normal manner, the key shielded inside the vehicle will be activated.

All doors locking

Press the button (1) to lock all doors, provided that all doors have been closed.

Note: All turn signal lamps flashing once represents the confirmation for locking; if any door is not fully closed, there will be no audio alarm, please press the button (1) again after closing all doors.

All doors unlocking

Press the button (2) to unlock all doors.

Note: If no door is opened within 30 seconds, all doors will be automatically locked again.

Before You Drive

Car locator

Long press the button (3) for 1 second, the vehicle will emit audible and visual alarm.

Remote door lock with PEPS

PEPS system allows you to lock or unlock the doors without taking the remote key out of your pocket, wallet, or suitcase.

Unlock with the remote key with PEPS

As long as there is a legitimate remote key existing within 1 meter around the vehicle, press the micro switch on the door handle, and the door will be unlocked.

Lock with the remote key with PEPS

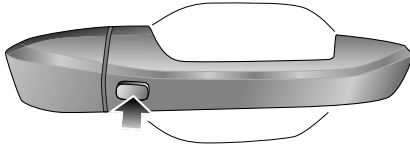

Turn off the ignition switch, leave the vehicle and close the door, then touch the micro switch on the door handle with your thumb, and the door will be locked, without pressing the lock button on the remote key.

Using the central door lock switch

All doors can be unlocked or locked from the inside using the switch. Press the lock button to lock all doors. Press the unlock button to unlock all doors.

Note: If driver door is not closed, the lock motor will not operate. If any other door is not closed, the lock motor will operate.

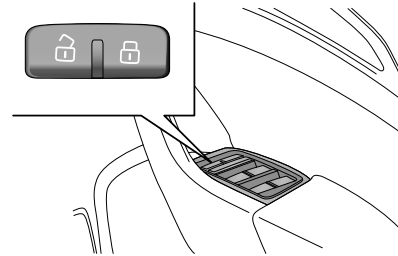

The door can also be unlocked by pulling the inner handle twice.

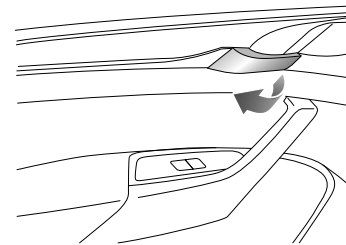

Before You Drive

Note: During the driving, all doors shall be fully closed and all door locks shall be enabled, so as to avoid accidental opening of doors.

Power-saving transportation mode

Note: Suitable for models equipped with power-saving transportation mode.

- Entering power-saving transportation mode

Turn on the ignition switch as well as the hazard warning lamp, press and hold the center console Lock button for 15 seconds, the instrument cluster will display that the transportation mode is ON (applicable to the instrument cluster equipped with such function) when a “click” sound is heard, and a flashing “body theft deterrent warning light (red)”

(red)”  indicates that the transportation mode is entered, then turn off the hazard warning lamp and lock the door with the mechanical key at this time.

Caution

After entering the transportation mode, the driver cannot locate the vehicle with the remote key, and can only lock/unlock the vehicle with the mechanical key, and the vehicle won't enter the defensive state (in which the vehicle will give an alarm with sound and light if the door of the vehicle is opened without the key) when it is locked with a mechanical key.

Caution

After entering the transportation mode, the remote monitoring module will be powered off and the vehicle will no longer possess the remote function. For vehicles equipped with keyless start, the PEPS remote key needs to be placed in the marked area of the storage compartment in front of the shift lever for ease of finding as the vehicle is started in the transportation mode. When the ignition switch is turned on in the transportation mode, the “body theft deterrent warning light (red)” will flash continuously.

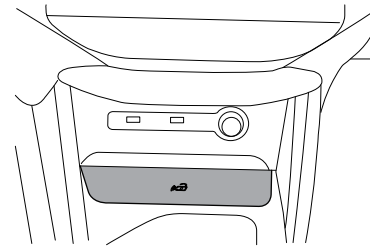

- Exiting power-saving transportation mode

Turn on the ignition switch as well as the hazard warning lamp, press and hold the center console Lock button for 15 seconds, the instrument cluster will display that the transportation mode is OFF (applicable to the instrument cluster equipped with such function), and the “body theft

Before You Drive

deterrent warning light (red)" will be off, which indicates that the power-saving transportation mode is exited.

Locking according to the vehicle speed

When the vehicle speed exceeds 8 km/h, all doors can be locked automatically under this function.

Note: When the key is turned to "LOCK" position, remove the key, and the doors will be automatically unlocked.

Tailgate

For models configured with tailgate key cylinder, the tailgate can be locked or unlocked by using the ordinary key or the mechanical key portion.

For models not configured with the tailgate key cylinder, the tailgate can be opened or closed directly through the outer handle on the tailgate.

You may open the tailgate through the outer handle on the tailgate, and fold the tailgate up to close it.

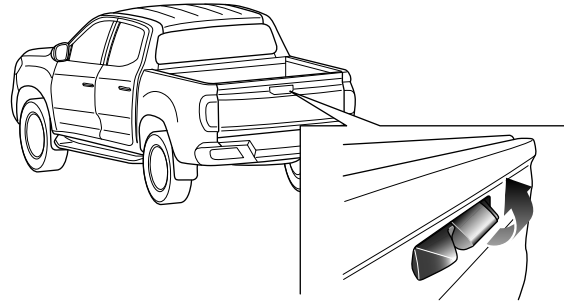

Note: During the driving, the tailgate shall be fully closed, so as to avoid accidental opening of tailgate.

Windows

! It is dangerous to leave children, incapacitated adults or pets on the vehicle with windows closed. They may faint out due to high temperature, or suffer permanent injury or even death due to heat stroke. Do not leave children, incapacitated adults or pets on the vehicle with the windows closed, especially in the warm or hot weather.

Power windows

! Always take care when operating the power window. There is a risk of injury, especially for children. Please pay close attention when closing the window. Ensure that no objects are stuck in it while the window is moving.

Driver door window

There are 4 window switches  on the driver door. You can operate driver door window, front passenger door window and rear door windows respectively with these 4 switches.

Press the front of the switch to open the window. Lift the front of the switch to close the window.

The driver may operate the lock switch  to disable the power windows of rear passengers. To enable this function, press the lock switch again.

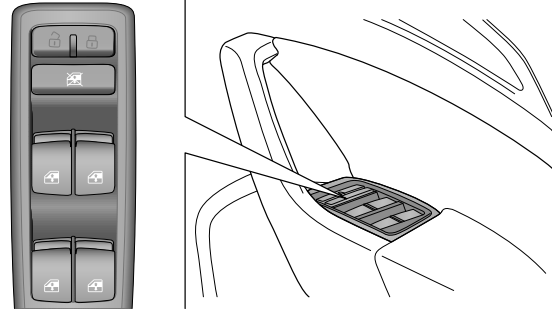

Automatic up/down function of window

Your vehicle may be configured with one-key up/down or one-key down function, please refer to the actual configuration of your vehicle. The window switch has 2 gears: automatic up/down and inching up/down, which can conveniently control the window glass up/down process. Briefly press the window switch up or down to the second gear, and the window glass will automatically move up or down.

Resume the automatic up/down function

If the vehicle battery cable is re-connected after the disconnection, or the battery was drained once, or the anti-pinch function has been enabled for consecutive 3 times at the same position when the window glass moves up, the automatic up/down function may not work, it must be re-learned to restore the function.

Before You Drive

Close all doors, pull up the window up/down switch, until the window is fully closed, hold the switch for about several seconds after the window is fully closed; then press the window up/down switch until the window is fully open, hold the switch for about several seconds after the window is fully open, the automatic up/down function will be recovered.

Passenger door windows

There is only 1 window switch on each passenger door , which can only operate the corresponding passenger door window.

Press the front of the switch to open the window. Lift the front of the switch to close the window.

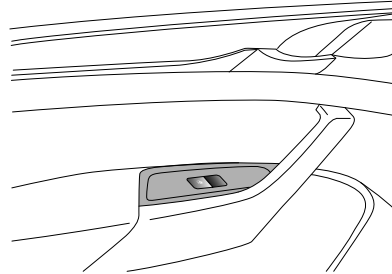

Note: Power windows can operate only when the ignition switch is in "ON" position.

Seats

Driver's seat adjustment

 Do not carry out driver's seat adjustment while the vehicle is moving. Otherwise, the vehicle may lose control and cause an accident.

Manually adjusted driver seat

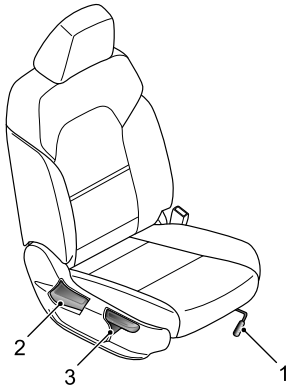

Forward/backward sliding

Pull up the handle (1), and slide the seat to the desired position. Release the handle (1) and confirm that the seat is locked in place.

Backrest adjustment

 Do not recline the driver seat excessively, as the seat belt provides maximum protection only when the angle between the backrest and the upright position is near 25°.

With the body tilting slightly forward, pull up the adjusting handle (2), the seat backrest will automatically bounce back, then recline against the seat backrest to adjust it to the desired angle. Release the adjusting handle (2) and confirm that the seat backrest is locked in place.

Cushion height adjustment

Pull up the adjusting handle (3) to raise the seat height, and press the handle (3) to lower the seat height. When making significant adjustments, it is required to pull up or press the handle (3) consecutively.

Before You Drive

Electrically adjusted driver seat

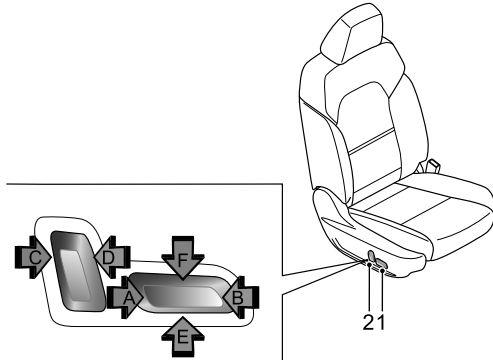

Caution

Regardless of where the ignition switch is placed, the seat can be freely adjusted. But the electrical adjustment is power consuming, which may drain the battery.

Forward/backward sliding

When the button (1) is pushed forward (arrow A), the seat will move forward, and when the seat slides to the desired position, release the button (1) to stop the seat sliding.

When the button (1) is pushed backward (arrow B), the seat will move backward, and when the seat slides to the desired position, release the button (1) to stop the seat sliding.

Backrest adjustment

! Do not recline the driver seat excessively, as the seat belt provides maximum protection only when the angle between the backrest and the upright position is near 25°.

When the button (2) is rotated forward (arrow C), the seat backrest will tilt forward, when the seat backrest tilts to the desired position, release the button (2) to stop the tilting.

When the button (2) is rotated backward (arrow D), the seat backrest will tilt backward, when the seat backrest tilts to the desired position, release the button (2) to stop the tilting.

Cushion height adjustment

When the button (1) is pulled upward (arrow E), the cushion will move upward, when the cushion raises to the desired position, release the button (1) to stop the cushion movement.

When the button (1) is pressed downward (arrow F), the cushion will move downward, when the cushion falls to the desired position, release the button (1) to stop the cushion movement.

Before You Drive

Front passenger seat adjustment

Manually adjusted front passenger seat

Only forward/backward sliding and seat backrest adjustment can be made, and its adjustment is consistent with that of manually adjusted driver seat.

Electrically adjusted front passenger seat

Its adjustment is consistent with that of electrically adjusted driver seat.

Rear occupant seat adjustment

Forward folding of seats

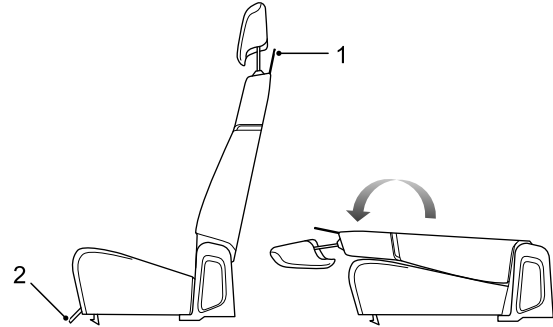

Pull up the tether (1) to unlock the backrest, fold the backrest forward until it snugs against the cushion.

When restoring the seat to its original position, rotate the backrest to the utmost rear end, and press the seat backrest rearward to lock it on the body. When restoring the seat to its original position, please note not to get the seat belt buckle stuck between the rear seat and the panel behind the rear seat.

Before You Drive

Rearward folding of seats

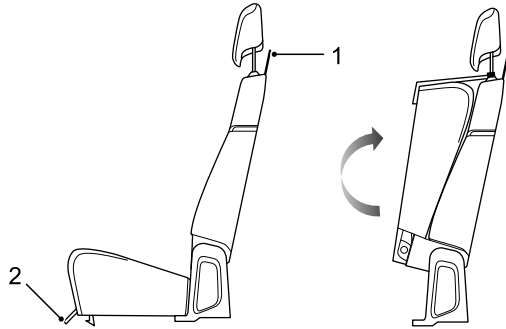

Pull the strap (2) forward below to unlock the cushion, fold the cushion backward until it snugs against the backrest. Take out the hook from the seat bag above the straps (2), then hook it to the head restraint guide rod.

When restoring the seat to its original position, withdraw the hook from the head restraint guide rod, fold the cushion to the utmost front end, and press the cushion down to lock it on the body.

Central armrest

Pull it down and push it forward for use.

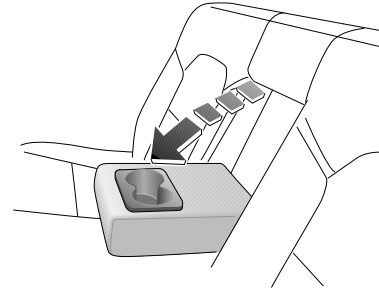

Caution

Do not sit on the central armrest or place heavy objects on it.

Headrest

Note: It applies to vehicles with adjustable headrest.

! To reduce the risk of neck or head injury, the headrest should be adjusted to support the back of the head but not the neck. Before driving, adjust the headrests of front and rear rows, and ensure that they are in lock position (i.e., the position for safe use). Do not adjust the headrest while the vehicle is in motion.

Press the arrowed button to push down or pull up the headrest to adjust the headrest to the desired position.

When pulling to a proper position, the headrest can be pulled out.

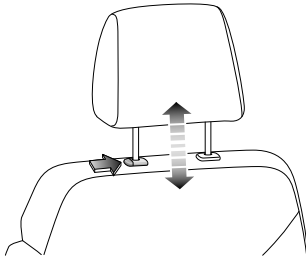

Passenger restraint system

Sitting correctly

The seat and its occupant restraint system have been designed to reduce personal injury to a minimum in the event of an accident. For optimum effectiveness, the following points should be observed.

- Do not position the seat nearer to the steering wheel than is necessary.
- Do not over-recline the seat. Adjust the rake of the backrest to no more than 30° angle so that you sit in an upright position with your arms slightly bent, and the base of your spine as far back as possible.
- Your headrest should be adjusted so that its center is level with the back of your head, not your neck.
- The shoulder belt should go through the center of your shoulder (adjust its height as necessary), while the lap strap fit tightly across the hips, not the stomach.

Before You Drive

Seat belts

 Improperly wearing or using seat belts may cause serious personal injury or death. Seat belts are life saving equipment. In a collision, unrestrained passengers may collide anywhere inside the vehicle or be possibly thrown out, resulting in injury to themselves or to other passengers.

When riding in a vehicle, the driver and any adult (or any adult sized child) must always fix the seat belt. Do NOT slacken the webbing by pulling the belt away from your body. To be fully effective, the webbing must remain tightly around your body at all times. Avoid wearing thick, bulky clothing. Put the shoulder belt of seat belt across the center of the shoulder and the lap belt close to the body to go over the hips. Strictly prohibit the use of slack and twisted seat belts, and seat belts can not be twisted to wear.

Never use a seat belt for more than one adult, and never use it to secure an additional object or a child. Each seat belt can only be used by one passenger. It's dangerous to wrap a seat belt around a child in the passenger arms.

When wearing a seat belt, ensure that it is not twisted or slack. Otherwise the smooth operation of the belt may be impeded. The buckle release button must face outwards.

 Do not allow a baby or infant to be carried on the lap. The force of a crash can increase effective body weight, making it impossible to hold onto the child.

Do not allow foreign matters (particularly sugary food and drinks) to enter the seat belt buckle- such substances may render the buckle inoperative.

If the seat belt has been used in a serious accident, or is seriously worn, or has been cut, or the visual load meter shows that the seat belt is no longer available, the seat belt assembly must be replaced.

Pregnant women should ask their doctor for advice about the safest way to wear seat belts.

A seat belt must not be altered or modified in any way, since such changes may render the belt ineffective. Do not attempt to dismantle, repair or lubricate the retractor or buckle mechanisms.

Each seat belt is fitted with a retractor. When the seat belt is pulled out slowly, the retractor can ensure that the seat belt is retracted freely. But if the seat belt is pulled out too fast or under a sudden impact (a sudden deceleration, acceleration, sharp turn), the seat belt will be locked. See "Seat belts" in Maintenance and Service section for the specific inspection methods.

Before You Drive

! When the seat belt is not used, be sure to retract the seat belt webbing completely, straighten the webbing and put the tongue in place, and keep the webbing and tongue clean to prevent dust and impurities.

Be careful to avoid the erosion of webbing by polishing agents, oils and chemicals (especially battery acid). It can be cleaned safely with mild soap and water. After wear, erosion or damage of the webbing occurs, the seat belt assembly should be replaced.

The driver and front passenger seats of the vehicles of this series can be configured with adjustable force-limiting seat belts without pretensioners, and the rear seats are equipped with three-point seat belts.

! Insert the tongue into the buckle until a distinct click is heard, which indicates the belt is locked.

Adjustable force-limiting seat belt without pretensioner

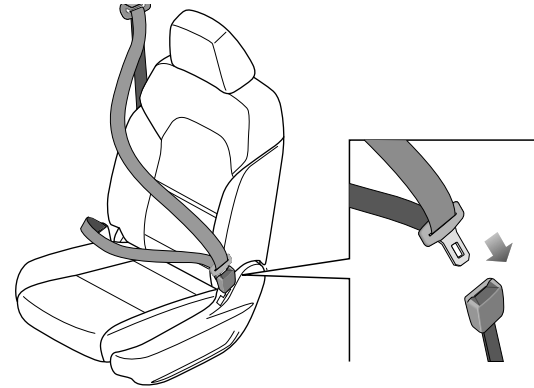

Fastening

The seat belt is pulled out of the scroll smoothly, passes through the shoulder to be fastened in front of the body, verify that the belt is not twisted or tied, then push the locking tab into the buckle.

Loosening

Press the red button on the buckle, then the tongue will pop out under the action of the elastic force. Push the tongue back manually, so that the automatic seat belt retractor can contract the whole seat belt more easily.

Before You Drive

Three-point seat belt on both sides of rear seats

The fastening and loosening methods for the three-point seat belt on both sides of rear seats are the same as that for front seat belts.

Three-point seat belt in the middle of rear seats

Fastening

Pull the seat belt out of the rear quarter, push the fixed tab (2) into the left buckle, then the movable tab (1) is passed through the abdomen and pushed into the right buckle.

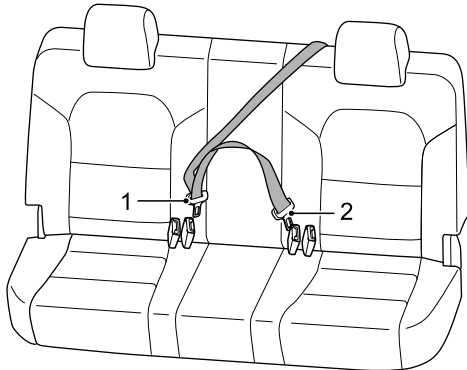

Loosening

The movable tab (1) is unlocked by pressing the red button on the right buckle.

The fixed tab (2) can be drawn out by inserting the key or other sharp objects into the left buckle unlocking hole. Push the tongue back manually, so that the automatic seat belt retractor can contract the whole seat belt more easily.

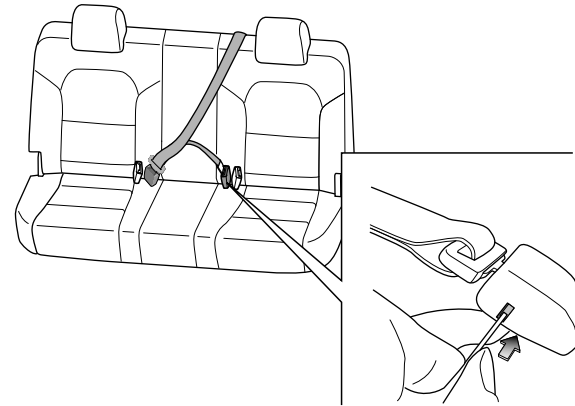

Seat belt warning light

See "Message center" and "Warning lights and indicators" in this section for the specific description of the "Seat belt warning light".

Before You Drive

Seat belt height adjustment

! Ensure that the slide adjuster is secure after making an adjustment.

Do not adjust the height of the driver seat belt while driving, as the control of vehicle may be lost.

Only the height of the driver seat and front passenger seat shoulder-to-hip belt can be adjusted.

Pull the button (1) outward and slide the vertical adjuster on the top of the belt up and down to suit the passenger height. Release the button (1) at the proper position, pull the seat belt forcibly to ensure that the height adjuster is locked reliably.

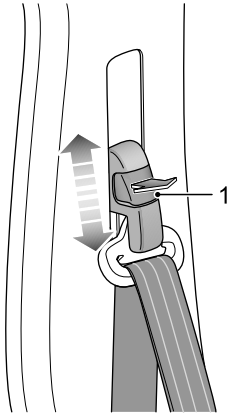

Airbag(s)

! No safety system can provide complete protection for personal injury or death in a severe crash. Injuries or death can occur, even if seat belts are worn properly and the airbags are inflated.

After inflation some airbag components are hot - Do NOT touch until they have cooled.

An airbag is inflated with considerable force and can cause facial abrasions and other injuries. These effects can be minimized by ensuring that you and your passenger(s) are wearing seat belts.

The driver seat should be adjusted to be as far rearwards as possible while maintaining the proper control of the vehicle.

Always hold the steering wheel by its rim, so that the airbag can be inflated without obstruction.

Never attach accessory items e.g. a mobile phone bracket, cup holder, cassette tray, etc. to the steering wheel cover or the airbag module cover, or stick/insert anything to an airbag module cover. Otherwise, these objects could interfere with inflation of the airbag. or after the airbag is inflated, they will be propelled into the vehicle to cause injury to passengers.

Before You Drive



Do not allow a passenger to obstruct the deployment of the airbag by putting feet, knees, etc. in contact with, or in close proximity to the airbag module cover.

Do not attempt to remove or pierce the steering wheel, or hit it violently.

Do not allow another person, animal or object to occupy the space between the driver and the deploying range of the airbag. The same applies on the passenger side if an airbag is fitted.

Do not attempt to maintain the steering wheel, steering column, any airbag system component, or the airbag components with wiring around. Otherwise, it could cause inadvertent activation of the system resulting in personal injury.

Do not modify the front of the vehicle in any way as this could adversely affect airbag deployment.

If the vehicle is to be scrapped, undeployed airbags are potentially dangerous and should be deployed before scrapping. This operation must be done by professional staff.

This series of vehicle can be equipped with the driver airbag, front passenger airbag, front seat side airbag and side curtain airbag.

Note: The airbag is a supplementary protection device, while the seat belt is still the main protection device and must be worn during driving.

Caution

- When an airbag is triggered, a loud noise may be heard and a small amount of smoke-like gas and dust will be released. This smoke does not constitute a health hazard. The dust may be an irritant to the skin and therefore should be washed off with soap and water.
- For safety reasons you are recommended to have the airbag(s) renewed by Our Service Dealer every 10 years. If the vehicle is sold, its owner is obliged to notify the purchaser of the cautions and warnings listed. This obligation is met by handing over these instructions (See Warranty & Service Handbook) to the new owner.

Before You Drive

Airbag check

 If the ignition switch is turned on, the warning light is not ON or OFF after 6 seconds, or ON when driving, it indicates that the airbag is faulty. Contact our Service Dealer for service as soon as possible.

The "Airbag warning light (red)" on the instrument cluster will flash for 6 seconds each time the ignition switch is turned to ON

position,  which indicates that the airbag inspection is in progress.

Airbag deployment

 Incorrect sitting posture or sitting or resting on the place close to the airbag will result in serious and even fatal injuries when the airbag is deployed.

In order to reduce the injuries caused during the airbag deployment, the seat belt must be always worn properly. The driver and front passenger must have a good sitting posture, and adjust their seat positions to enable them to be far enough away from the front airbag, so as to avoid causing serious injury or death when the airbag is deployed. For vehicles equipped with side airbags and side air curtains, it is also important to ensure that upper extremities are far enough away from the side of the vehicle, avoiding injuries due to airbag deployment.

When the airbag is deployed, children not properly protected may suffer serious injury and even death. Do not allow children to ride on a vehicle without protection, and it is prohibited to stick any part of the body out of the window.

The airbag deployment may cause body surface abrasion or bruise or burns due to explosion.

There must be no obstacle in the airbag inflation channel. It is prohibited to place any object between the passenger and the airbag. It is prohibited to fix or place any object on the steering wheel cover or

Before You Drive

the frontal airbag cover of instrument cluster and its vicinity. It is prohibited to place accessories around the airbag system. If there is obstacle between the passenger and the airbag, the airbag may not be properly inflated, or squeeze the obstacle into the body of passenger, causing serious injury or death.

Do not knock on or crash the airbag or positions of relevant components, to avoid causing serious injury or death due to airbag deployment.

When it is deployed, some airbag components are hot, so do not contact it before cooling down.

In case of crash, airbag control module detects speed change caused by crash to determine airbag deployment. The airbag will deploy instantaneously and powerfully with a loud noise.

When the vehicle is subject to serious front crash, fully deployed airbag along with properly worn seat belt can limit the movement of the driver and the front passenger, thereby reducing the risk of injury to the head and chest. For vehicles equipped with side airbags and side air curtains, if the side of vehicle is seriously crashed, fully deployed side airbag will form an air cushion between the passenger and the side of vehicle, thereby reducing the risk of injury to the side of passenger body.

When you are sitting upright in the seat and leaning against the seat backrest, the seat belt and the airbag can provide the most effective protection. In case of a serious crash, the airbag deploys violently. At this moment, if you or other passenger does

not properly use the seat belt, and tilts the body forward, reclines or has other incorrect posture, the possibility of serious injury or death in an accident will be high.

Caution

- The airbag cannot protect the lower part of passenger body.
- The airbag is not designed for rear collision or slight frontal impact or vehicle overturn, and it does not work during the emergency braking.
- Airbag deployment and contraction are completed in a very short time, and will not provide protection from effects of possible subsequent second impact.
- Upon deployment, the airbag will shrink immediately to ensure the driver could look forward without block.

Before You Drive

- Schematic diagram for deployment area of driver and front passenger airbags

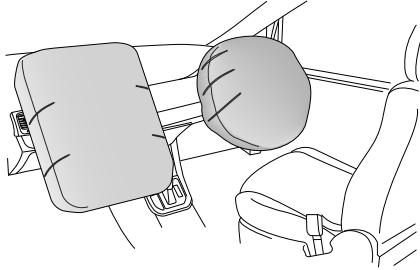

- Schematic diagram for deployment area of side air curtains

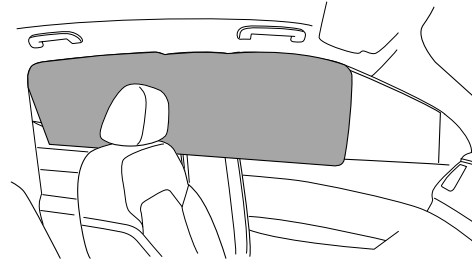

- Schematic diagram for deployment area of front seat side airbags

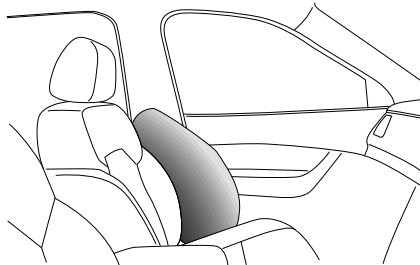

Before You Drive

Frontal airbag

! Do not install the children restraints on the front passenger seat. Frontal airbag deployment will cause serious injury or death to children.

The driver and the front passenger shall not let their feet, knees or other parts of body contact with or get close to the frontal airbag cover

The airbag may deploy in the event of violent jolt or accidental impact to the vehicle chassis. Therefore, be extra careful when driving on a bumpy road, to avoid injuries caused by accidental airbag deployment.

The frontal airbag is designed to deploy in the event of front impact or similar collision. The airbag will deploy under any of the following situations or similar situations.

- Front impact at a relatively high speed with solid wall which cannot move or deform.

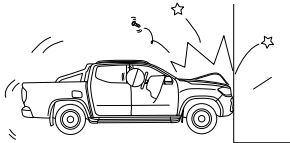

- When the vehicle chassis is seriously damaged. When the vehicle collides with the curbstone, road pavement edge or

solid surface, and falls into the deep ditch or deep hole, or violent contact with the ground after vehicle jump may cause serious damage to the chassis.

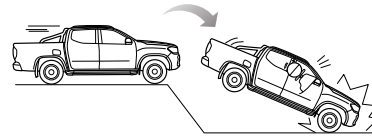
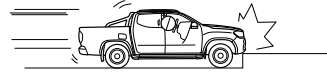

Before You Drive

Side airbag

⚠ The structure and material of seat is critical for the operation of airbag. Therefore, do not install the seat cover, which will affect the deployment of side airbag.

In case of serious side impact, the front seat side airbag on the side subject to impact will pop out from the seat cover and deploy rapidly. The side airbag on the side not subject to impact will not deploy. The side airbag will deploy under any of the following situations or similar situations.

- Side impact occurs between the vehicle and the general passenger car at a relatively high speed.

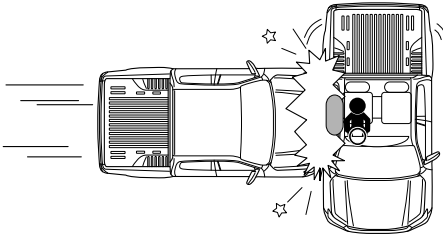

Side air curtain

In case of serious side impact, the side air curtain on the side subject to impact will pop out from the headliner and deploy rapidly. The side air curtain on the side not subject to impact will not deploy. The side air curtain will deploy under any of the following situations or similar situations.

- Side impact occurs between the vehicle and the general passenger car at a relatively high speed.

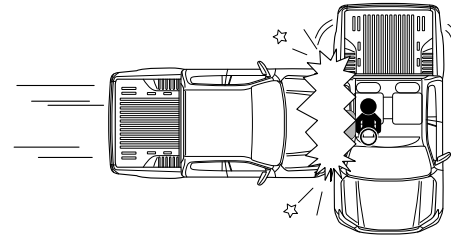

Before You Drive

Conditions for airbag undeployment

Airbag will deploy based on the crash object, direction and vehicle deceleration caused by crash rather than vehicle speed. When the impact force of crash is absorbed or dispersed on the vehicle body, the airbag may not deploy; but based on the impact condition during the accident, the airbag may sometimes explode. Therefore, damage severity of vehicle shall not be considered as the judgment of airbag deployment.

Frontal airbag

The side airbag may not deploy under any of the following situations or similar situations.

- When the impact direction deviates from the center of vehicle.
- When front impact occurs with solid electric pole, traffic sign post, trees and other small objects.

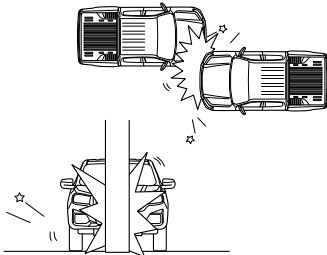

- Impact with lower part of truck tailgate; piercing-type impact with truck or vehicles with higher chassis.
- Front offset impact with guardrail.

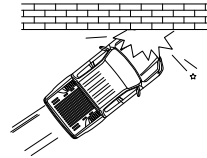
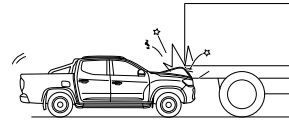

- Side or rear impact.
- Vehicle rollover.

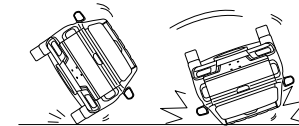

Before You Drive

Side airbag and side air curtain

The side airbag and side air curtain may not deploy under any of the following situations or similar situations.

- Impact at a certain angle with the side.
- Side impact with a two-wheel motorcycle.

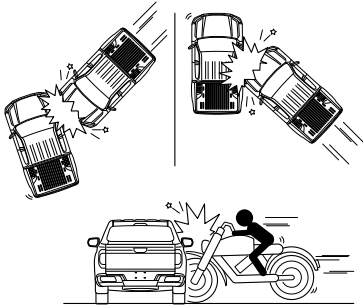

- Side impact with the front compartment of vehicle.
- Side impact with the rear of vehicle.
- Vehicle rollover.

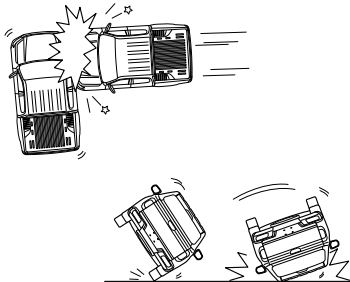

- Front offset impact with guardrail.
- Side impact with a post.

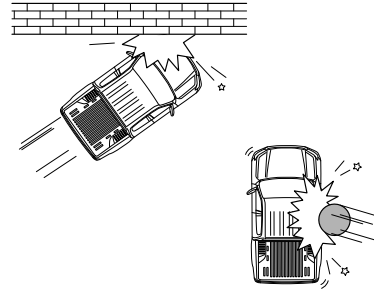

- Front impact with a stationary or moving vehicle.
- Rear impact.

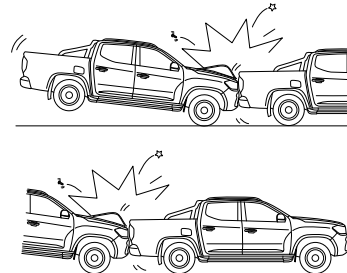

Before You Drive

Replace airbag system components after a collision accident

 The airbag system could be damaged due to a collision accident. Thus the airbag system cannot operate normally to protect you and passengers in future collision accidents resulting in serious injury even death. To ensure the airbag system remains valid after a collision accident, consult Our Service Dealer to make inspection and necessary replacement of components.

Once the airbag is inflated, it is required to replace the components of the airbag system. Contact Our Service Dealer for service as soon as possible.

Child restraints (not supplied with the vehicle)

 **May result in death or serious injury!**
The airbag can kill the children under 12-year old. The backward-facing child or infant restraint device is prohibited being installed on the front seat, otherwise it will result in the serious children or infant injury or death when the airbag is expanded. Seat yourself far away from the airbag as possible as you can.



Observe the instructions provided by the infant or child restraint device's manufacturer if you are installing or using such device.

WARNING: child restraint anchorages are designed to withstand only those loads imposed by correctly fitted child restraints. Under no circumstances are they to be used for adult seatbelts, harnesses, or for attaching other items or equipment to the vehicle.

As a child is much easier to be injured by the expanded airbag than an adult, so a child under 12 years old is suggested taking the rear seat. Usually, infants under 2 years old shall use a infant restraint and children under 2-4 years old shall use the child restraint. Infant or child restraints are available in the market.

Before You Drive

Because there are various size and types of infant or children restraints, you are recommended to choose the suitable protection device depending on the infant's or children's age and weight to achieve the best protection. At the same time, you should check that the restraint is suitable for your vehicle as well.

Child restraint anchor

This vehicle has 4 ISOFIX standard interfaces on the three-abreast rear seat and some models also have 2 TOP TETHER interfaces on the seat back panel. Observe the instructions provided by the child restraint seat manufacturer for removal and installation.

Installation methods for child restraints

- 1 Route the top tether strap over the seatback and attach to the corresponding child restraint anchorage hook, being careful not to twist the strap. When securing, you must make sure that the top strap passes through the seat headrest(This step only applies to those models with TOP TETHER anchorage). Unless using ISOFIX lower anchorages, use the seatbelt complete the installation in line with the child restraint manufactures instructions.
- 2 Insert the child restraint into the ISOFIX retaining rings until it is engaged reliably, the heard "click" sound indicates that it is installed in place.

- 3 When ISOFIX is correctly connected, press down the child restraint with your body and tighten the ISOFIX tether to fix the seat firmly on the vehicle.

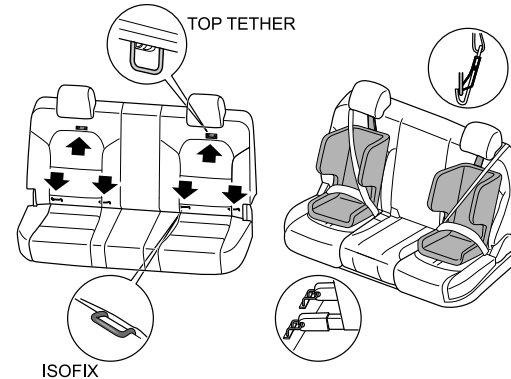

Caution

It is preferable to fit the infant or child restraint on the rear seat. In the case the infant or child restraint must be positioned on the front seat while the vehicle is in motion, the infant or child restraint must face forward. No matter what location, ensure properly secure the infant or child restraint. Note that an unsecured infant or child restraint may move and run into other passengers when any crash or heavy braking occurs. Even if there is no infant or child, any infant or child restraint must be properly secured in the vehicle.

Before You Drive

Instruments and controls

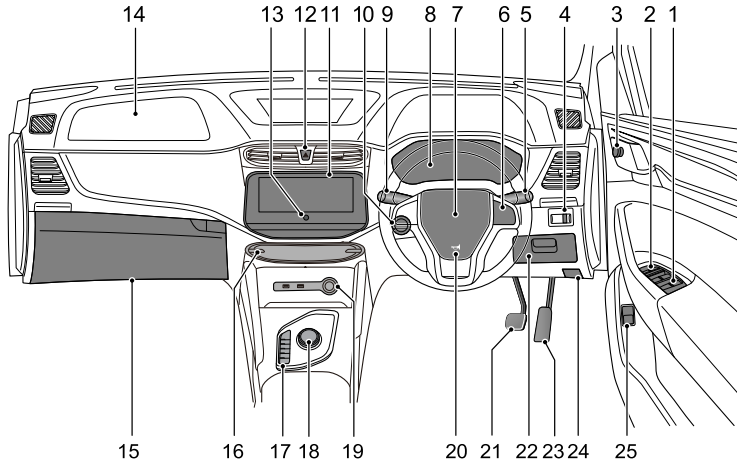

- 1 Door window control switches
- 2 Central control door lock switch
- 3 Exterior rearview mirror power adjustment switch
- 4 Headlight leveling switch
- 5 Combination lamp control and direction indicator lamp stalk, instrument cluster setting switch
- 6 Volume control, mute, audio source and bluetooth
- 7 Driver airbag
- 8 Instrument cluster
- 9 Wiper and washer stalk, instrument cluster menu switch
- 10 Ignition switch
- 11 Entertainment system
- 12 Hazard warning lamp switch
- 13 Entertainment system control switch
- 14 Front passenger airbag
- 15 Glove box
- 16 A/C control panel
- 17 Floor console switch
- 18 Shift knob
- 19 USB port, 12V power socket
- 20 Horn button
- 21 Brake pedal
- 22 Storage compartment
- 23 Accelerator pedal
- 24 Front compartment hood release switch
- 25 The charging port panel release switch

Instrument cluster

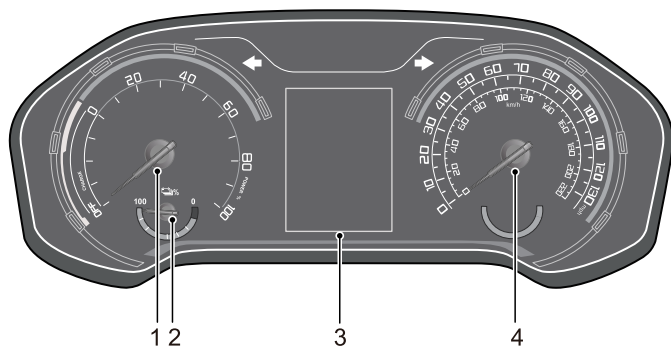

- 1 Drive motor power percentage gauge
- 2 High-Voltage battery pack electric quantity
- 3 Information center
- 4 Speedometer

Caution

Don't place any object in front of the instrument cluster to avoid shielding dial and warning light.

Drive motor power percentage gauge

Displays the power percentage of the power system.

A value below zero represents a negative percentage; a value above zero represents a positive percentage.

If the drive motor power percentage is displayed as a positive value, it means that the power system outputs power to drive the vehicle; if the drive motor power percentage is displayed as a negative value, it means that some of the kinetic energy of the power system is converted into electric energy.

High-Voltage battery pack electric quantity

It indicates the state of high voltage battery pack electric quantity. When the electric quantity of the battery is too low, the red strip-type bar will be lit, and the "High-Voltage battery pack low battery warning lamp (yellow)" will be lit.

Note: A low high-voltage battery pack will make some functions of the vehicle lose effect.

Caution

When the high-voltage battery pack is low, the battery will be charged as soon as possible.

Ensure enough power is stored in the high-voltage battery pack before running.

Once the battery is fully charged, the battery management system will have an automatic calibration function. If the vehicle has been shallowly charged (less than 99%) every two or three times, you need to fully charge (100%) the vehicle once.

Before You Drive

Speedometer

The speedometer indicates the current road speed in miles per hour or in kilometers per hour.

Information center

The information center display screen is located in the middle of instrument cluster.

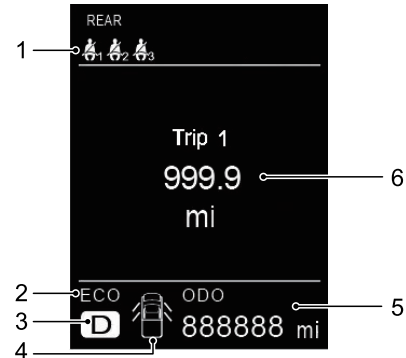

1 Driving Mode

It displays the current driving mode of the vehicle. The information center of the instrument pack displays: ECO(Economy mode), PWR(Sport mode). You can switch the driving mode through the ECO and PWR switches on the console.

2 Gear display

3 Door ajar reminder

4 Total mileage

5 Trip computer interface

6 Rear seat belt warning light

Trip computer interface

Short press the instrument cluster menu switch button  on the combination switch to switch between the following interface contents:

- Trip A

Displays the driving mileage of the vehicle since last setting. The trip will automatically reset to zero and continue counting after it reaches the maximum reading. Reset the trip by long pressing the instrument cluster setting switch SET button on the combination switch.

- Trip B

Displays the driving mileage of the vehicle since last setting. The trip will automatically reset to zero and continue counting after it reaches the maximum reading. Reset the trip by long pressing the instrument cluster setting switch SET button on the combination switch.

- Average power consumption

It displays the power consumption per 100 km. The average value is the average power consumption of the vehicle since the last reset. Reset the trip by long pressing the instrument cluster setting switch SET button on the combination switch.

- Instantaneous power consumption

This function automatically displays the instantaneous power consumption.

- Driving range

It displays the mileage that the vehicle can travel before the high-voltage battery pack runs out of power.

Note: *The driving range is related to the driving conditions, vehicle status, use of accessories, etc. When the battery is low, the driving range is for reference only.*

- Remaining maintenance mileage

This message reminds you of the remaining mileage of your vehicle before the next maintenance.

The remaining maintenance mileage can be reset through key operation: in the remaining maintenance mileage interface, quickly and briefly press the instrument cluster setting switch SET button on the combination switch for 5 times within 3 seconds to reset the maintenance mileage.

- Average speed

Average speed displays the approximate average speed calculated on the basis of the accumulated mileage and ignition switch-on time recorded in the menu item since last reset. It can be reset by long pressing the instrument cluster setting switch SET button on the combination switch.

- Current speed

It displays the current speed.

- Tire pressure information

In normal mode, it displays the current tire pressure in real time.

Before You Drive

Note: For vehicles equipped with the tire pressure monitoring system, after tires are inflated or deflated in static state, the tire pressure display value will not be updated until the vehicle speed reaches 30km/h.

- High-voltage battery voltage

It displays the current high-voltage battery voltage.

- High-voltage battery current



It displays the current high-voltage battery current.

- Drive motor speed

It displays the current drive motor speed.

Note: If the vehicle is not equipped with relevant functions, this interface will not be displayed.

Fault message interface

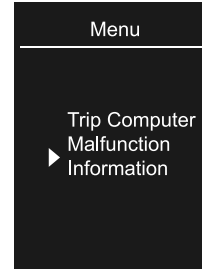

Long press the instrument cluster menu switch button  to enter the menu selection interface; short press the instrument cluster menu switch button  to select "Fault message".

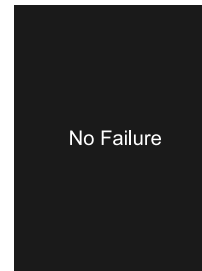

Short press the instrument cluster setting switch SET button on the combination switch to enter the fault message interface. "No fault at present" will be displayed if there is no fault.



The corresponding warning message interface will be displayed if there is any fault.

Short press the instrument cluster menu switch button  on the combination switch to switch between the warning interfaces. Long press the instrument cluster menu switch button  on the combination switch to return to the previous interface.

Note: The fault message interface can be operated only when the vehicle speed is zero. It will automatically return to the Trip Computer interface when the vehicle speed is more than zero. It will automatically return to the Trip Computer interface if no operation is conducted within 10s.

Caution

If multiple warning messages exist at the same time, they are displayed in order of priority.

Alarm messages

Most of alarm messages will have a corresponding graphic and text description in the instrument cluster. If more than one alarm message is activated, the new alarm message will be first displayed for 9 seconds, then the alarm messages will be displayed in a cycle; each alarm message will be displayed for 3 seconds. Some alarm messages will be displayed in a cycle. Only when the alarm is canceled will the cycled alarm disappear.

Please operate in strict accordance with the instructions in the alarm message. If there is no relevant instructions, please stop the vehicle for inspection or consult our Service Dealer.

Important alarm messages

The currently displayed important alarm message can be temporarily canceled by short press the instrument cluster setting switch SET button on the combination switch. It can also be viewed in the alarm query interface after canceled.

Caution

For the user's safety, when the door is open or the vehicle is in driving status, the alarm message cannot be canceled by short pressing the SET button. The user must close the door and enter the trip computer interface to perform relevant operations when the vehicle is stationary.

If all the alarm messages are canceled, the trip computer information will be displayed normally. When the conditions

Before You Drive

of alarm activation are canceled, the corresponding alarm messages are also canceled to display.

Indicative messages

Indicative messages disappear automatically after 3 seconds.

Caution

Don't neglect the alarm messages, otherwise it may cause serious damage to the vehicle. If the warning light is on, please stop the vehicle as soon as possible if it is safe to do so.

Service interface reminders

Next maintenance reminder

This message reminds you of the remaining mileage of your vehicle before the next maintenance.



Remaining
Distance to Service
999
mi

Warning lights and indicators

Direction indicator



The left or right "direction indicators (green)" flash when making a turn. When the hazard warning light switch is pressed, the left and right direction indicators flash simultaneously.

Note: If a direction indicator flashes rapidly, it indicates that the bulb in this direction indicator is faulty.

Headlight high beam indicator



The "headlight high beam indicator (blue)" illuminates when the headlights are on high beam or flash on.

Rear fog light indicator



The "rear fog light indicator (yellow)" illuminates when the rear fog lights are on.

Position light indicator



The "position light indicator (green)" illuminates when the position lights are on.

Airbag warning light



When the ignition switch is turned to ON position, if the "airbag warning light (red)" illuminates or flashes, it indicates that the airbag system is faulty. Contact Our Service Dealer for service as soon as possible.

Seat belt warning light

Note: This vehicle can be equipped with the front passenger and rear seat belt unfastened warning functions, which shall be subject to the actual configuration of the vehicle you purchased.



When the ignition switch is turned to ON position, if the driver seat belt is not fastened correctly, the "seat belt warning light (red)" will illuminate. When the speed is greater than 22 km/h, if the driver seat belt is not correctly fastened, the instrument cluster will activate a seat-belt-unfastened audible warning, and the "seat belt warning light (red)" will flash for about 90 seconds. When the seat belt is fastened, the "seat belt warning light (red)" goes out and the audible warning stops. When the vehicle is in reverse gear or the speed is less than 10 km/h, if the driver seat belt is not correctly fastened, the instrument cluster will not activate any audible warning, while the "seat belt warning light (red)" will illuminate. When the seat belt is fastened, the "seat belt warning light (red)" goes out.

Before You Drive

When the ignition switch is turned to ON position, if the front passenger seat belt (equipped with front passenger seat belt unfastened warning function) is not fastened properly, the "seat belt warning light (red)" will illuminate. When the speed is greater than 22 km/h, if the front passenger seat belt is not correctly fastened, the instrument cluster will activate a seat-belt-unfastened audible warning, and the "seat belt warning light (red)" will flash for about 90 seconds. When the seat belt is fastened, the "seat belt warning light (red)" goes out and the audible warning stops. When the vehicle is in reverse gear or the speed is less than 10 km/h, if the front passenger seat belt is not correctly fastened, the instrument cluster will not activate any audible warning, while the "seat belt warning light (red)" will illuminate. When the seat belt is fastened, the "seat belt warning light (red)" goes out.

When the rear passenger seat belt (equipped with rear passenger seat belt unfastened warning function) is not fastened properly, the "seat belt warning light (red)" illuminates. When the speed is greater than 22 km/h and the rear passenger seat belt (equipped with the rear passenger seat belt unfastened warning function) is not properly fastened, the instrument cluster activates a seat-belt-unfastened audible warning, and the "seat belt warning light (red)" flashes for about 90 seconds and there is seat map showing the specific unfastened seat. When the rear passenger seat belt (equipped with the rear passenger seat belt unfastened warning function) is fastened properly, the "seat belt warning light (red)" goes out and the audible warning stops. When the speed is less than 10 km/h and the passenger seat

belt (equipped with the rear passenger seat belt unfastened warning function) is not properly fastened, the "seat belt warning light (red)" illuminates. When the rear passenger seat belt (equipped with the rear passenger seat belt unfastened warning function) is fastened properly, the "seat belt warning light (red)" goes out.

Note: Opening the door will reset the time when the seat belt warning light flashes. Front passenger and rear passenger seat belt unfastened warning function can only be triggered when there is passenger on the seat.

Brake system warning light



When the ignition switch is turned to ON position, if the brake fluid level is abnormal or the brake system breaks down, the "brake system warning light (red)" will illuminate. Please immediately stop the vehicle safely, and contact Our Service Dealer for service as soon as possible.

ABS (Anti-lock Braking System) warning light



When the ignition switch is turned to ON position, the "ABS warning light (yellow)" illuminates and goes out after several seconds.

If the ABS warning light fails to go out or illuminates again while driving, it indicates that the ABS breaks down; please contact our Service Dealer for service as soon as possible.

Note: The brake system can be used even if ABS is faulty (ABS failure). See "Brake system" in Starting and Driving section for important information about ABS.

EBD (Electronic Brake Distribution) warning light



When the ignition switch is turned to ON position, if the "EBD warning light (red)" illuminates while driving, it indicates that the brake system is faulty. Please contact Our Service Dealer for service as soon as possible.

ESC (Electronic Stability Control) indicator



When the ignition switch is turned to ON position, "ESC indicator (yellow)" flashes when the electronic stability control system is operating. If the indicator illuminates, it indicates that the electronic stability control system is faulty, please contact Our Service Dealer for service as soon as possible.

ESC (Electronic Stability Control) OFF indicator



When the ignition switch is turned to ON position, if the ESC OFF switch is pressed to disable the ESC function, the "ESC OFF indicator (yellow)" will illuminate.

See "Brake system" in Starting and Driving section for more information.

HDC (Hill Descent Control) indicator



When the ignition switch is turned to ON position, if the HDC function is enabled, the "HDC indicator (yellow)" illuminates. When the HDC system is working, "HDC indicator (yellow)" flashes. When the HDC function is disabled, "HDC indicator (yellow)" goes out. See "Dashboard switch" in this section for information on the HDC switch.

If the hill descent is turned off or the system is faulty, "HDC indicator (yellow)" goes off. Please contact Our Service Dealer for service as soon as possible. See "Brake system" in Starting and Driving section for more information.

EPS (Electric Power Steering) system MIL



When the ignition switch is turned to ON position, the "EPS system MIL (red)" illuminates and goes out after several seconds.

If the EPS system MIL fails to go out or illuminates again while driving, it indicates that the EPS system breaks down; please stop the vehicle immediately, and contact our Service Dealer for service as soon as possible. See "Power steering unit" in Starting and Driving section for more information.

Before You Drive

Drive motor theft deterrent warning light



When the ignition switch is turned to ON position, if the theft deterrent authentication is successful, the "drive motor theft deterrent warning light (yellow)" goes out and the vehicle can start. If the warning light flashes, it indicates that the theft deterrent control system is faulty and the vehicle will not start. Please contact our Service Dealer for service immediately.

Body theft deterrent warning light



When the vehicle enters the antitheft state, the "body theft deterrent warning light (red)" flashes.

When the vehicle exits the antitheft state, the "body theft deterrent warning light (red)" goes out.

If the theft deterrent alarm is triggered, the "body theft deterrent warning light (red)" flashes, accompanied with audible and visible alarm.

Battery no-charge warning light



When the ignition switch is turned to ON position, the "battery no-charge warning light (red)" illuminates and goes out after the vehicle is started.

Caution

If the light fails to go out after the drive motor is started or illuminates while driving, it indicates that the charging system breaks down. Please contact our Service Dealer for service as soon as possible.

Drive motor overheat warning light



When the ignition switch is turned to the ON position, the "drive motor overheat warning light (red)" illuminates, and goes out after several seconds. When the drive motor is hot, the light flashes. Please contact our Service Dealer for service as soon as possible.

Power system failure warning light



When the ignition switch is turned to the ON position, the "power system failure warning light (red)" illuminates, and goes out after several seconds. When the power system fails, the light illuminates. Please contact our Service Dealer for service as soon as possible.

High-voltage battery pack low warning light



When the ignition switch is turned to the ON position, "high-voltage battery pack low warning light (yellow)" illuminates,

Before You Drive

and goes out after several seconds. If the warning light stays on, or illuminates again during driving, it indicates that the high voltage battery pack is too low in power and needs to be charged as soon as possible. Please recharge as much as possible before the light comes on.

Note: *The warning light is on to indicate that the vehicle speed limit function is enabled. The vehicle speed will decrease along with the battery power drop until it stops.*

High-voltage battery pack failure warning light



When the ignition switch is turned to the ON position, "high-voltage battery pack failure warning light (red)" illuminates, and goes out after several seconds. If the warning light stays on, or illuminates again during driving, it indicates that the high voltage battery pack is faulty.

Charging connection indicator



When the charging gun is connected to the charging port, the "charging connection indicator (red)" illuminates.

Charging status indicator



When the high-voltage battery pack is charging, the "charging status indicator (yellow)" on the instrument pack

illuminates. When the high-voltage battery pack is fully charged, the indicator goes out.

When the high-voltage battery pack is being heated, the "charging status indicator (yellow)" on the instrument cluster illuminates.

Note: *If the "charging status indicator (yellow)" flashes, it means that battery is faulty and it cannot be charged. Contact our Service Dealer for service as soon as possible.*

Ready indicator



This light is used to indicate that the vehicle is ready to go. After the vehicle is started, the "READY indicator (green)" illuminates, and it will not go out during driving.

Caution

Before the "READY indicator (green)" illuminates, press the A/C switch and the A/C compressor will not work. Before the "READY indicator (green)" illuminates, do not turn on the blower control knob, and do not use headlights, radios and other electrical appliances for a long time. There is a risk that the vehicle cannot move.

Before You Drive

Insulation failure warning light



When the ignition switch is turned to the ON position, the "insulation failure warning light (red)" illuminates, and goes out after several seconds. If the warning light stays on or illuminates again during driving, it indicates that there is a insulation failure.

Limited power indicator



In normal driving conditions, the "limit power indicator (yellow)" remains off. When the "limited power indicator (yellow)" of the vehicle illuminates, the power of the vehicle will be limited, and the acceleration performance will be greatly reduced, please contact our Service Dealer for service as soon as possible.

Trailer indicator

Note: It applies to vehicles configured with trailer indicator.



When the ignition switch is turned to the ON position, if the trailer is connected successfully, when the turn signal lamp is turned on, "trailer indicator (green)" on the instrument cluster flashes. When the trailer connection fails, "trailer indicator (green)" on the instrument cluster goes off.

Instrument panel switch

Headlamp leveling switch

The headlamp leveling switch is located on the instrument panel at driver side, which is on the outboard side of the steering wheel.

With this function, the headlamp leveling can be adjusted to the condition suitable for vehicle and road. The correction of headlamp leveling can reduce the dazzling light to other drivers.

To adjust the headlamp leveling, headlamp low beam must be turned on.

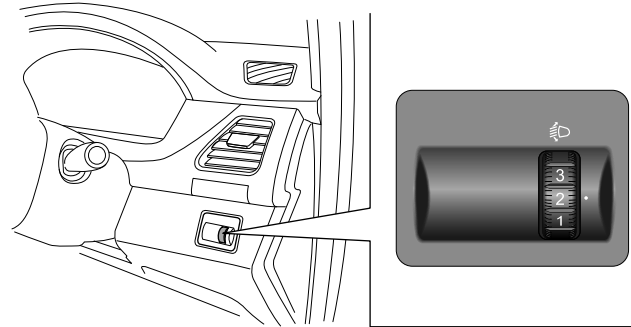

Adjust the headlamp leveling by moving the thumbwheel upwards or downwards. With the change of vehicle load, please adjust headlamp leveling in accordance with the following requirements.

- Position 0: The front passenger seat is occupied.

Before You Drive

- Position 1: All seats are occupied.
- Position 2: All seats are occupied and there is goods in the cargo compartment.
- Position 3: The driver's seat is occupied and there are goods in the cargo compartment.

Hazard warning light switch

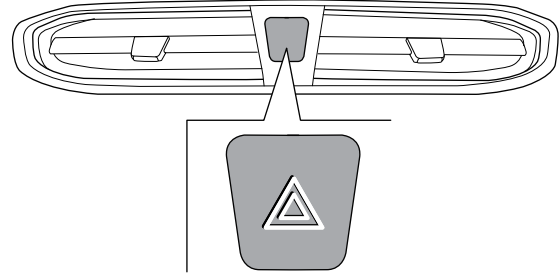



Press the hazard warning light switch  to activate all the turn signal lamps simultaneously, and the "direction indicator (green)" in the instrument cluster will illuminate and flash. Press the switch again to turn off the above lights.

Note: *Turn on hazard warning lights to prompt other vehicles that your vehicle has a malfunction and approaching your vehicle may be dangerous.*

Before You Drive

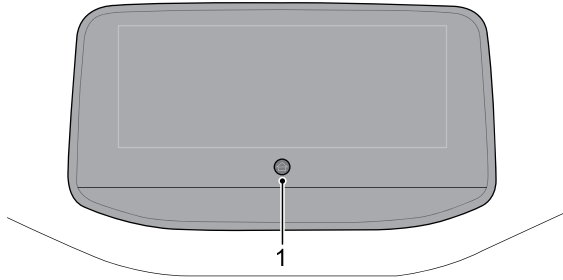
Entertainment system control switch



Position 1 — : HOME Button. In main interface mode, long press for about 3 seconds to power off, then press for about 10 seconds to restart.

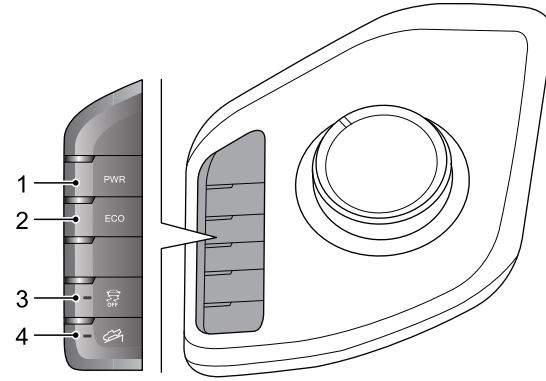

Floor console switch





Position 1—PWR: PWR (Power mode) switch. Press the PWR switch, the vehicle's drive mode is switched to PWR (Power mode), and the "PWR indicator" on the instrument cluster illuminates, under the PWR (Power mode), the output power of vehicle drive motor is relatively strong.

Position 2—ECO: ECO (Economy mode) switch. Press the ECO switch, the vehicle's drive mode is switched to ECO (Economy mode), and the "ECO indicator" on the instrument cluster illuminates, under the ECO (Economy mode), the output power of vehicle drive motor is relatively weak.

Before You Drive

Position 3 – : ESC OFF switch. Press , then the indicator lamp in the switch will illuminate and the ESC system will be turned off. Press the button again to activate ESC system; only ABS and EBD functions work after ESC is turned off. Please refer to "Brake System" in the Starting and Driving section for relevant ESC instructions.

Position 4 – : Hill descent control switch. Press , then the indicator lamp on the switch will go on and the HDC function will be enabled. Press the button again to turn off the HDC function. Please refer to "Brake System" in the Starting and Driving section for relevant HDC instructions.

Switches on steering column and steering wheel

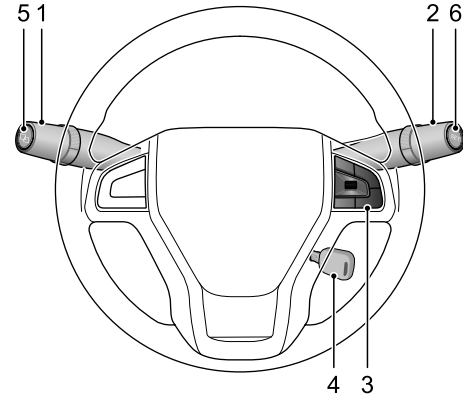

- 1 Wiper & washer stalk switch
- 2 Combination lamp control & direction indicator lamp stalk switch
- 3 Volume control, mute, audio source and Bluetooth phone switch
- 4 Ignition switch and steering lock
- 5 Instrument menu switch
- 6 Instrument setting switch

Before You Drive

Ignition switch and steering lock

Pull out the key. Then the steering lock will be activated to prevent the steering wheel from rotating.



In order to pull out the key from the ignition switch, please turn the key to ACC position. Then press the key towards the ignition switch and continue rotating it to LOCK position. At this time, the key can be pulled out.

Note: If the key on the ignition switch is not pulled out, there will be warning sounds when the driver door is opened.

Please refer to "Ignition Switch" in the Starting and Driving section for more information about ignition switch positions.

Combination lamp control & direction indicator lamp stalk switch

Lighting control switch

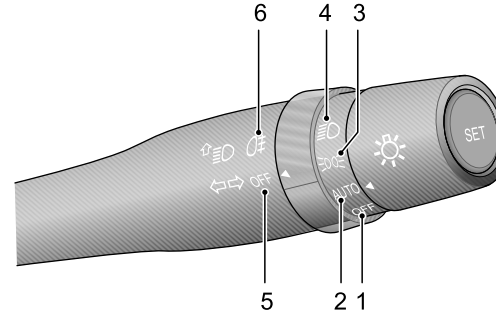

Shift the lighting control switch to the position as shown in the figure, and the corresponding lamps will illuminate.

Position 1 – OFF: Headlamps off. Daytime running lamps will automatically illuminate after the vehicle is started.

Position 2 – AUTO: Headlamp automatic adjustment. When the headlamp switch is placed in AUTO position, headlamps will illuminate/go off according to the lighting brightness of ambient environment. Daytime running lamps will automatically illuminate when other lamps are not turned on after the vehicle is started.

Before You Drive





Position 3 – : Width lamps on. When width lamps are turned on, the following lamps will be turned on meanwhile:

- Width lamps
- License plate lamp
- Instrument panel lamp

Position 4 – : Headlamps low beam on.

Note: Headlamps can be turned on only when the ignition switch is placed in ON position. If headlamps are not turned off when the vehicle is parked, battery will discharge. Then the vehicle may be unable to start due to low battery. When the ignition switch is placed in LOCK position or the key is pulled out, there will be warning sounds if the headlamp switch is still turned on.

Position 5 – OFF: fog lamp off.

Position 6 – : Rear fog lamps on. When the ignition switch is placed in ON position and the lighting control switch is placed in high beam or  low beam position, turn the switch to , and then rear fog lamps will be turned on. When the lighting control switch is placed in AUTO position, turn the switch to , and then rear fog lamps will illuminate or go off along with headlamps according to ambient environment. When the rear fog lamps are turned on, the rear fog lamp indicator lamp (yellow) on the instrument cluster will illuminate.

Note: Rear fog lamps shall not be used until the visibility is obviously restricted (such as heavy fog or snow).

Turn signal lamps and direction indicator lamps

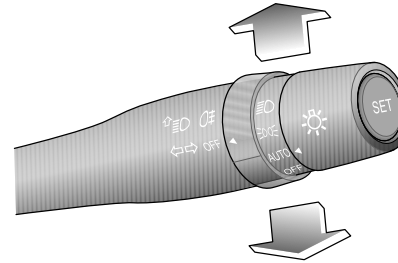

Turn right – push the shifter lever switch upwards.

Turn left – pull the shifter lever switch downwards.

Then the corresponding turn signal lamp and the "direction indicator lamp (green)" on the instrument cluster will illuminate simultaneously.

Before You Drive

High beam and low beam lamps

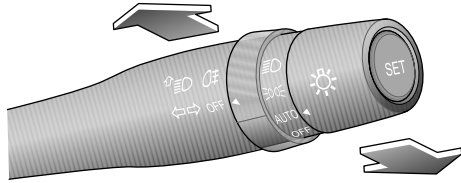

Push the shifter lever switch away from the steering wheel to change the headlamp mode from low beam to high beam. Pull the shifter lever switch close to the steering wheel to change the headlamp mode to low beam.

Note: *When the headlamp mode is high beam, the "headlamp high beam indicator lamp (blue)" on the instrument cluster will illuminate. To shift the headlamp mode to flashing, slightly lift the shifter lever switch towards the steering wheel intermittently.*

Daytime Running Lamps

Daytime running lamps make it easier for others to see the front of the vehicle during daytime.

If your vehicle is equipped with daytime running lamps, when the ignition switch is in "ON" position, the daytime running lamps will illuminate. When the daytime running lamps illuminate, the headlamp low beam, tail lamps, width lamps, and other lamps will not illuminate. When the ignition switch is in "OFF" position, the daytime running lamps will go off.

Meet the regulatory requirements of ECE R87 daytime running lights.

Before You Drive

Wiper & washer stalk switch

Front windshield wipers and washer

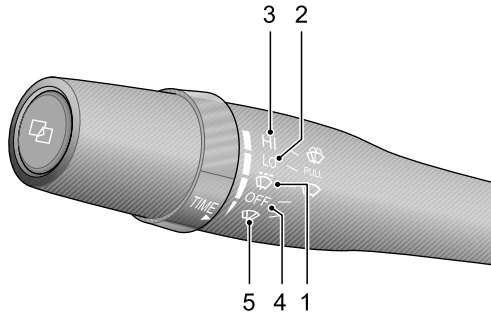

Place the shifter lever switch to the position required.

Position 1 – : Intermittent wiping. For a vehicle equipped with an automatic wipers, its rain sensor will detect the rainfall on the windshield and automatically adjust the wiping frequency of windshield wipers.

Note: *Ensure the rain sensor is free of dust, dirt and ice.*

Position 2 – LO: Low-speed wiping.

Position 3 – HI: High-speed wiping.

Position 4 – OFF: Turn off wipers.

Position 5 – : Single wiping.

Before You Drive

Intermittent wiping/interval adjustable

! If worn wiper blades cannot clear rain from the front windshield, the forward visibility will be lowered, which may lead to an accident. Be sure to replace worn wiper blades in time.

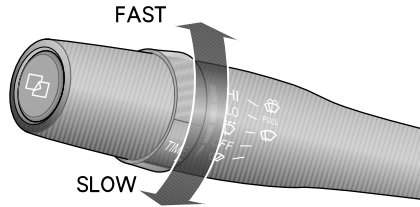

When the shifter lever switch is placed in  (intermittent) position, turn the switch to change the wiping interval.

Caution

In cold or hot days, in order to prevent damaging wipers, please clear barriers from the windshield (such as snow) if wiper blades are frozen or adhere to the windshield. Do not operate wipers when leaving the windshield dry. Otherwise the windshield may be damaged, wiper blades may be worn prematurely, and the driver's vision may be affected.

Washer

Pull the shifter lever switch towards the steering wheel, and the washer will start operating immediately. After a transient interval, wipers and washer will operate in linkage. The washer will be turned off after the shifter lever switch is released.

Note: After the shifter lever is released, wipers will continue conducting wiping operations for 3 times.

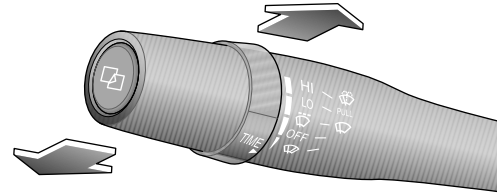

Volume control, mute, audio source and Bluetooth phone switch

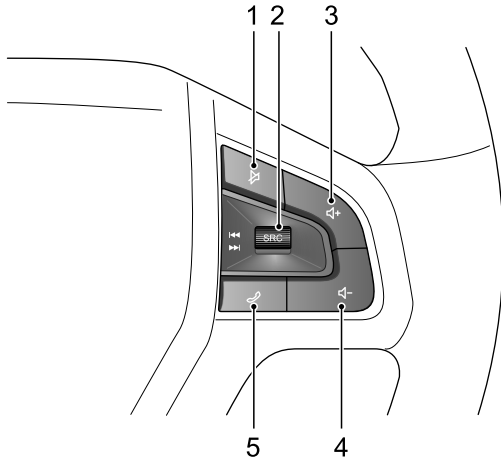

Position 1—: Mute switch.

Position 2— Audio source and control thumbwheel switch upwards or downwards.

- SRC: Audio source switch. Repeat pressing this button to change playback mode. The system will cycle among the following options: radio, music, etc.
- Control the thumbwheel knob upwards or downwards: move the thumbwheel upwards to select the previous preset station or previous CD/MP3 track; move the thumbwheel downwards to select the next preset station or next CD/MP3 track.

Position 3—: Volume up control switch.

Position 4—: Volume down control switch.

Position 5—: Bluetooth phone switch. This button is the phone answering switch when Bluetooth is connected. In the general calling state: In case of an incoming call, short press this button to answer; long press this button to hang up; during a call, short press this button to hang up. In the call waiting state: Short press this button to hung up the call waiting; long press this button to answer the call waiting.

Before You Drive

Steering wheel adjustment

! Do not adjust the steering wheel position during driving. This is extremely dangerous.

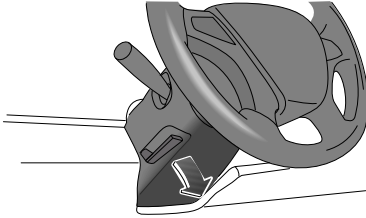

Adjust the steering wheel position to adapt to your driving posture through the following steps:

1 Fully release the steering wheel adjusting handle on the steering column downwards;

2 Grasp the steering wheel firmly with both hands, and move the steering wheel upwards or downwards to adjust it to a proper position;

Note: If it is still difficult to move the steering wheel to a proper position, place the ignition switch in ON position to unlock the steering wheel, and turn the steering wheel to the straight forward position.

3 Select a proper driving position, and pull the steering wheel adjusting handle fully up to lock the steering wheel into its new position.

Horn

Regardless of the ignition switch position, the horn can work once you press the button.

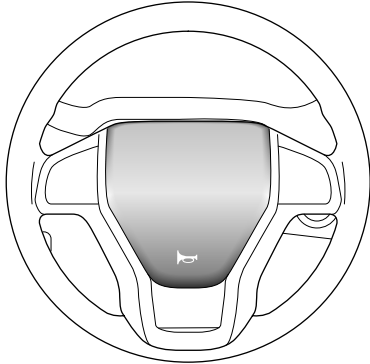

Heating, ventilation and air conditioning

The air conditioning system can cool down the air and remove the moisture and the dust (eg, pollen) in the air.

The heating system utilizes the high voltage electronic heater, so the interior air heating function can be realized only when the vehicle is supplied with a high voltage.

The ventilation system ensures the interior ventilation when driving.

The air speed selection button for the front and rear A/C controls the air volume.

HVAC is used to control the cooling, heating and ventilation of the air inside the vehicle. Fresh air is drawn into the vehicle through the air intake grille under the windshield, and flowing through the air conditioning filter. Always keep the air intake grille clean, free of obstructions such as leaves, snow or ice.

Before You Drive

Front vents

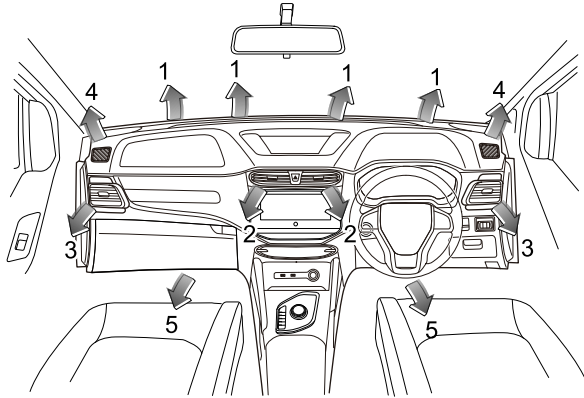

- 1 Windshield vent
- 2 Center vent
- 3 Side vent
- 4 Front window vent
- 5 Front footwell vent

Center vent

Move the lever (1) in the center of the grille up and down, right and left to change the direction of the air distribution.

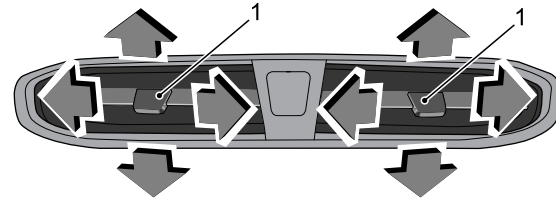

Before You Drive

Side vent

Move the lever in the center of the grille up and down, right and left to change the direction of the air distribution.

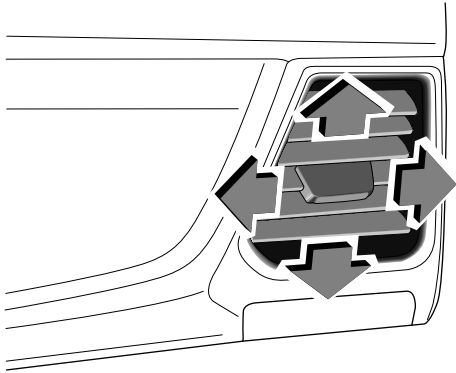

Rear vent

Rotate the thumb wheel (1) to adjust the air volume from the vent. Move the lever (2) in the center of the grille up and down, right and left to change the direction of the air distribution.

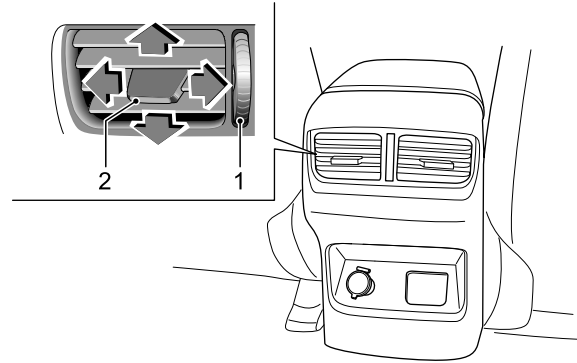

1

Before You Drive

Electronic A/C control panel

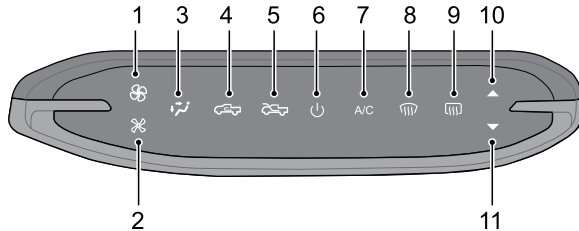

- 1 Air volume increase button
- 2 Air volume decrease button
- 3 Mode button
- 4 Internal circulation button
- 5 External circulation button
- 6 Power button
- 7 A/C button
- 8 Front defrost button
- 9 Rear defrost button
- 10 Temperature increase button
- 11 Temperature decrease button

Air volume increase button

Turn on/off and increase the blower air volume.

The air volume increases by one level with each touch, and the maximum air volume corresponds to Level 8.

Air volume decrease button

Turn on/off and decrease the blower air volume.

The air volume decreases by one level with each touch, and the minimum air volume corresponds to Level 1.

Mode button

The mode is adjusted once with each touch, and the sequence of mode adjustment is Air Distribution to Face, Air Distribution to Face and Footwell, Air Distribution to Footwell, and Air Distribution to Footwell and Defrost.

Internal circulation button

When the internal button is pressed, the characters illuminate in yellow to indicate the internal circulation state.

External circulation button

When the external button is pressed, the characters illuminate in yellow to indicate the external circulation state.

When the external button is pressed, the internal button in yellow are off. Regardless of the on/off of A/C panel, the internal/external circulation operates normally to execute the corresponding functions.

Power button

Control the on/off of the A/C system.

Touch the power button to turn on the A/C and return to the non-defrost state before turning off, and the characters illuminate in yellow. Touch the power button again to turn off the A/C, and meanwhile the characters enter the red backlight state.

A/C button

Switch on and off the compressor

Touch the A/C button to turn on the compressor (the vehicle has been started), and the characters illuminate in yellow; press the A/C button again to turn off the compressor, and meanwhile the characters enter the red backlight state.

Front defrost button

Switch on the front defrost state.

If the front defrost button is operated, meanwhile the characters illuminate in yellow, and the default features include external circulation, A/C on, and defrost as the air outlet mode. In the Front Defrost state, press the Front Defrost button or other mode buttons again to exit the defrost state, and the characters return to the red backlight state.

Rear defrost button

Switch on the rear defrost state.

When the rear defrost button is operated, the characters illuminate in yellow, and the rear defrost function is enabled, the on/off of which will not affect other A/C states.

For vehicles equipped with heated exterior rearview mirrors, the function of heated exterior rearview mirror will be automatically enabled when the rear defrost is activated, helping remove fog or frost from the surface of the rearview mirror.

Note: Enabling/disabling this function will not affect other A/C states. The rear defrost will be automatically disabled after being operated for 15 minutes, and the corresponding indicator will be turned off.

Temperature increase button

Turn on/off and increase the A/C target temperature.

The temperature increases by 1°C with each touch, and the maximum temperature is 33°C with HI displayed.

Temperature decrease button

Turn on/off and decrease the A/C target temperature.

The temperature decreases by 1°C with each touch, and the minimum temperature is 17°C with Lo displayed.

Before You Drive

Recommendation for A/C operation

- If the vehicle is parked in a place that is exposed to the direct sunlight, open the windows before operation.
- If the fogged windows need to be cleaned in a rain day, reduce the moisture in the vehicle by operating the air conditioning. This is very effective in rainy season and a season with heavy moisture.
- If the vehicle is driving in the city, the stop-and-go may cause the insufficient cooling.

Note: *If the air conditioning will not be in use for more than one month, run the vehicle at idle speed and turn on the system for more than 10 minutes (once every month, including in winter). This aims to maintain the proper lubrication of the compressor and the seals, so as to extend the service life of the system.*

Note: *Condensation may be formed on the evaporator when the A/C is operating. So you may find a small pool of water under the vehicle after the vehicle is stopped.*

Rearview mirrors

In order to extend the view range, exterior rearview mirrors are convex-shape, which makes objects look smaller and farther than the actual.

Caution

Be sure to check and ensure that all rearview mirrors are clean and bright, and adjusted well before driving; clean and adjust them if necessary.

Exterior rearview mirrors

Power rearview mirrors

Press the switch L(left) or R(right) to select the rearview mirror to be adjusted. Move the rearview mirror switch towards front/rear/left/right to adjust the rearview mirror lens to tilt towards up/down/left/right to the position required. Move the switch to the middle position.

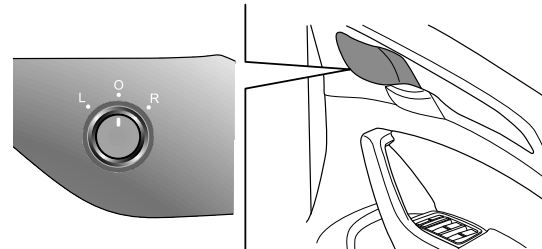

Before You Drive

Folding rearview mirrors

In order to ensure the safety of pedestrians, exterior mirrors will rotate from their normal mounting positions towards both sides if impacted with a strong force. Reset the rearview mirrors by applying little pressure onto the mirror frames.

Interior rearview mirror

Adjust the rearview mirror to obtain the required rear view.

Operate the adjusting lever on the bottom of rearview mirror to reduce reflected glare during night driving.

1

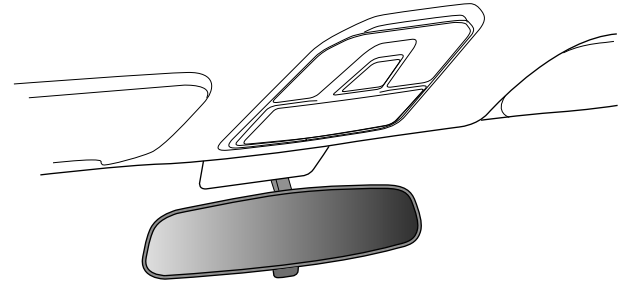

Interior equipment

Front roof vanity light

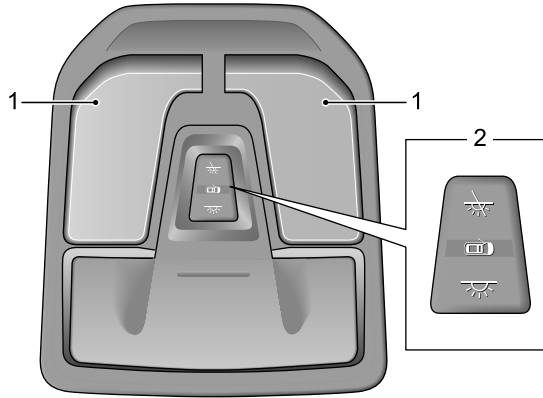

- 1 Left/right front roof vanity light control switch
- 2 Three-gear switch

Front reading lamp control

When the three-gear switch (2) is located at , the front roof vanity light is turned on.

When the three-gear switch (2) is located at , the front roof vanity light will automatically illuminate after any door is opened and go off 30s after the door is closed. After the door is closed, press the left/right front roof vanity light control switch (1) to turn on and off the corresponding front roof vanity light.

When the three-gear switch (2) is located at , press (1) to turn on and off the corresponding front roof vanity light.

Rear roof vanity light



On/off switch

When the front ceiling reading lamp button is placed in the door control position and all doors are closed, press ☀ to turn on rear ceiling reading lamps; press ☀ again to turn off rear ceiling reading lamps.

When any door is opened, rear ceiling reading lamps will go on. About 30s after the door is closed, rear ceiling reading lamps will go off automatically.

Note: 15min after any door is opened, rear ceiling reading lamps will go off automatically to prevent battery drain.

On-board inverter

! Please pay attention to electric safety during usage. Prevent children from contacting this outlet. **Danger! High voltage! Do not insert finger or a conductive object into this outlet. Please keep liquid objects away from this outlet. Do not use it in a humid, hot (more than 85°C) and unventilated environment. The maximum rated power of inverter is 150W. Do not use any electric appliance with a power more than 150W.**

On-board inverter is located behind the bottom of central armrest between the driver and front passenger seats. Open the panel, and you will see the 220V AC power outlet, which can provide an output power of 150W. When the ignition switch is placed in "ACC" position, the on-board inverter will start operating. Please pay attention to the indicator lamp showing the power supply operating state near the outlet during usage, and operate according to the prompts provided by the indicator lamp:

- 1 Green lamp on: Normal operation.
- 2 Indicator lamp off: low battery voltage. Please remove the electrical appliance, and wait for the battery voltage to return to normal.
- 3 Red lamp flashes:
 - High battery voltage. Please wait for the battery voltage to return to normal.

Before You Drive

- 220V power supply temperature is excessively high. Please remove the electric appliance and wait for the green lamp to go on.
- 220V power supply output overload. Please remove the electric appliance and restart the vehicle to recover normal operation.
- External short circuit. Please remove the electric appliance and restart the vehicle to recover normal operation.

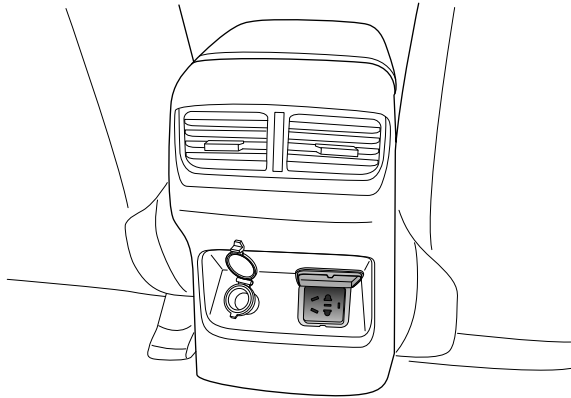

12V power outlet

12V power socket provides power supply connection for external electric devices. 12V power sockets are respectively located at the center bottom of dashboard and on the rear bottom of central armrest, which are subject to the actual configuration of the vehicle you purchased.

Caution

Please avoid using the power socket for a long time when the ignition switch is placed in "ACC (unlocked)" position, which will lead to battery drain.

Note: *The power socket can provide power supply for electric devices of which power is no more than 120W.*

Caution

Please avoid using the on-board inverter for a long time when the ignition switch is placed in ACC position, which will lead to battery drain.

Before You Drive

12V power socket located at the center bottom of dashboard

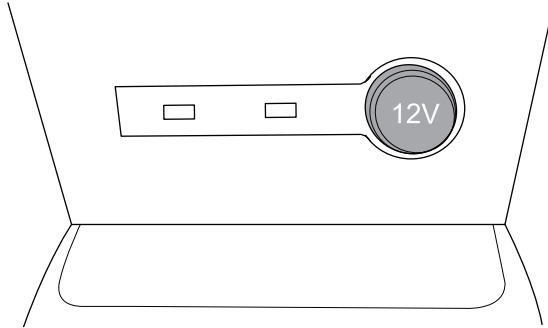

12V power socket located on the rear bottom of central armrest

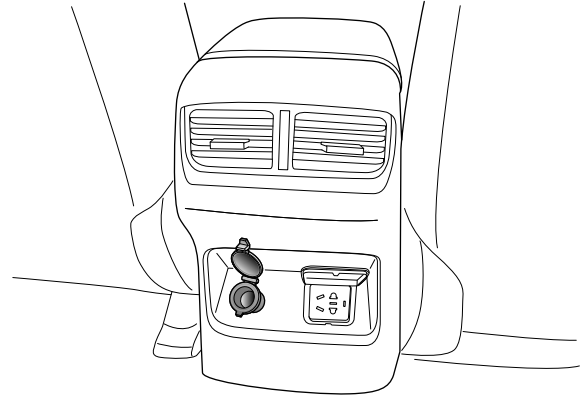

1

Before You Drive

USB port

The USB ports are located at the center bottom of dashboard. The left USB port can support audio/video playback, picture browsing, charging and mobile phone interconnection. The right USB port can support audio/video playback, picture browsing, charging.

Caution

Please avoid using the USB ports for a long time when the ignition switch is placed in "ACC (unlocked)" position, which will lead to battery drain.

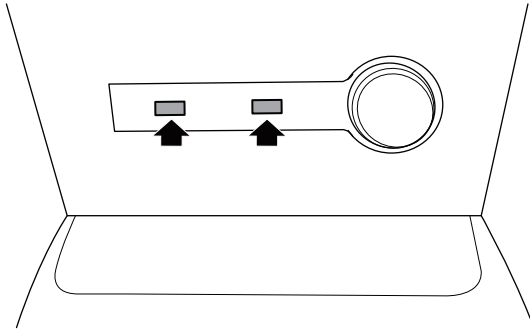

Cup holders

The cup holders are located on both sides of instrument panel. To open a cup holder, push it inwards and then release it to unlock, and then pull it outwards completely. To retract the cup holder, keep pushing it inwards until it is locked.

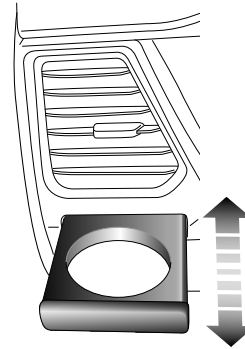

Before You Drive

Storage box

The storage box at driver side is located below the cup holder at driver side. It can be opened by releasing the storage box upper buckle.

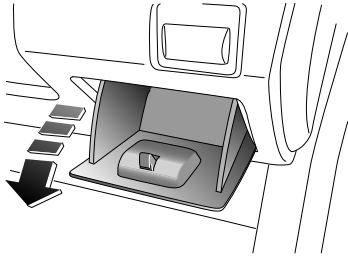

Glove box

! Do not place a sharp, heavy or hazardous object in the glove box at front passenger side.

In case of an accident or sudden braking, the glove box may cause personal injury if not closed. Therefore, please close the glove box during driving.

Press the PUSH button on the upper left side of glove box to open the glove box (if your vehicle is equipped with a glove box lock, you need to insert the key and turn it counterclockwise to unlock). Push it hard to close it.

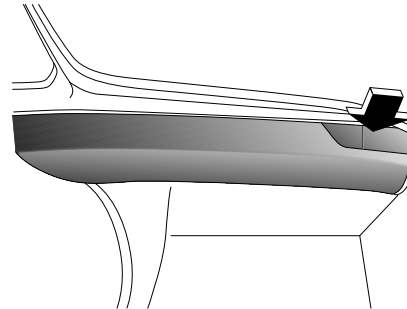

Before You Drive

Sun visor and vanity mirror

Pull both sun visors upwards or downwards to block the sunshine through windshield. Besides, sun visors can be rotated towards side windows.

Turn a sun visor downwards and open the vanity mirror cover. Then you can use the vanity mirror.

Driver's vanity mirror shall be used only when the vehicle stops.

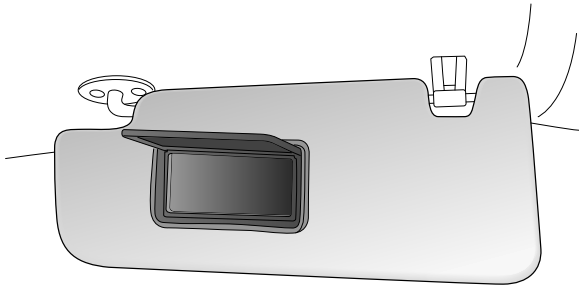

MP5+Radio

Precautions before use

The contents of this Handbook are simple instructions for the operation of the product. Please read carefully and fully understand the operating instructions accompanied with the entertainment system head unit before you use this product.

⚠ Please do not install or repair your product without authorization. If the product is installed or repaired by a person who does not receive the training on electronic equipment and auto parts, a dangerous situation may be posed. Never expose the product to any liquid, otherwise short circuit or damage may be caused.

According to the relevant national regulations, watching videos and related operations are prohibited when driving, for the personal safety of yourself and others. Please do not watch the screen and perform related operations when driving a vehicle.

Please pay attention to all precautions mentioned in this section of the Handbook and strictly follow the operating instructions.

The rear view camera function of the system just serves as a driving assist. Please pay attention to the actual situation.

Before You Drive

Caution

- The product shall be kept away from moisture.
- If the product is started for the first time or reconnected after the disconnection of vehicle power supply, the date shown on each interface of the head unit needs to be adjusted manually.
- Be sure to drive safely. Make sure to follow the rules of safe driving and existing traffic regulations.
- Do not operate the product (and the rear view camera function) if it may distract you from safe driving.
- If you have to operate by watching the screen, park the vehicle in a safe place and apply the parking brake.
- Do not set the volume of the product too high, or you will not be able to hear the traffic and emergency signals outside.
- For the sake of safety, some features, such as video playback, will be disabled when driving.
- The system can detect the running speed of the vehicle. When the speed exceeds a certain value, the system will prevent you from watching video while driving. If you want to watch the video, park the vehicle in a safe place and apply the parking brake.
- To prevent the battery from running out, make sure to start the vehicle when using the system.
- The pictures in this Handbook are schematic diagrams which may be slightly different from the real car in details and are for reference only. As for the specific colors and functions of the interface, please refer to the real car.

Entertainment system control switch

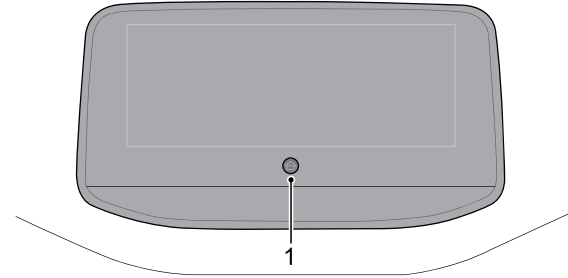

1 HOME Button

In main interface mode, long press for about 3 seconds to power off, then press for about 10 seconds to restart.

Before You Drive

Introduction and operation of main interface functions

Status bar



- 1 Current playback display
- 2 Bluetooth/USB connection display
- 3 Volume display
- 4 Time display

Application center

For the related guide, we prepare for a user manual on the homepage of the screen. Please click and see.

- 1 Click the central icon on the bottom.



- 2 Click the User Manual.

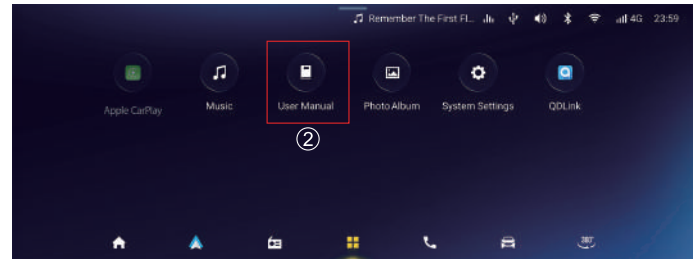

Starting and Driving

- 80 Before starting and driving
 - 80 Ignition switch
 - 83 PEPS system
 - 85 Starting/Stopping
 - 86 Driving
 - 87 Gear shifting
 - 88 Charging requirement
 - 102 Acoustic vehicle alerting system (AVAS)
 - 103 Electric power steering unit
 - 103 Brake system
 - 110 Parking assist system
 - 113 Tires
 - 115 Loading
 - 119 Trailer towing
-

Starting and Driving

Before starting and driving

- Ensure that the daily/weekly maintenance checks have been done as detailed in the section "Maintenance and Service - Owner's Check".
 - Check that the seat is in the right position.
 - Check that the adjustment of all the rearview mirrors is in place.
 - Check that all lights, signal systems and warning indicators operate normally.
 - Check that all passengers have correctly fastened seat belts.
- Move the ignition switch in "ON" position, and check all warning lights and gauges operate normally. Please see "Warning lights and indicators" in Before You Drive section.

Caution

Be sure you have read the "Before You Drive" section of this Handbook and a good understanding of your vehicle and its equipment before reading this section.

Ignition switch

Key start



Never remove the key during vehicle driving, otherwise you will not be able to steer the vehicle.

Always remove the key after switching off, particularly if leaving children unattended in the vehicle.

Freewheeling with the ignition switched-off is dangerous as assistance from the brake booster and the power steering is not available under these conditions.

Ignition switch can offer positions below:

LOCK: Ignition switch turned off. The key can only be inserted or removed in this position. After removing the key from "LOCK" position, the ignition switch shall lock the steering column to avoid turning the steering wheel.

ACC (unlock): With steering column unlocked, individual electrical device and accessory can work, such as radio, etc.

Note: *You may need to slightly rotate the steering wheel to unlock the steering lock.*

Note: *Do not leave the key in "ACC" position for a long time, so as to prevent unnecessary battery power loss.*

Starting and Driving

ON: The ignition is switched on and instruments, controls and electrical circuits become operative.

START: The starter motor runs and vehicle is started. After the vehicle is started, release the key immediately, and the key will automatically return to "ON" position from "START" position.

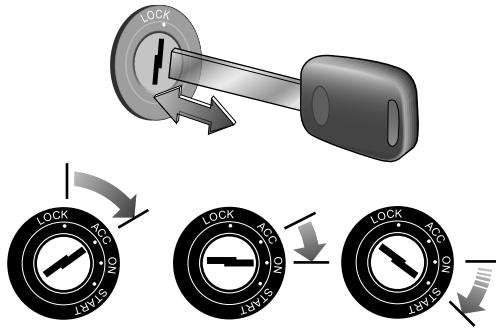

Keyless start

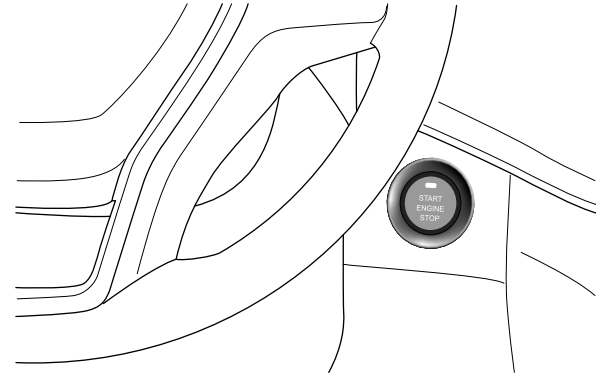

2

Note: The vehicle is equipped with an one touch start switch, that is, the ignition switch for button-type start. To start the vehicle, the remote key with PEPS feature must be in the vehicle. If you want to move the shift knob out of park gear, you must depress the brake pedal with the ignition switch placed in ON position.

ACC - red light

- Start failure

In case of the vehicle start failure, the ignition switch will switch to ACC.

- Abnormal parking

Starting and Driving

When the vehicle is driving and the shift knob is not in N position, press this button and the ignition switch will switch to ACC.

- Emergency flameout

When the vehicle speed is higher than 5km/h during driving, press the ignition switch for 3 times continuously or long press it for 3s, the ignition switch will switch to ACC.

ON - green light

When the motor is not running and the starting conditions are not met, press this switch once, the ignition switch will switch to ON; after the motor is normally started, the ignition switch will switch to ON; when in ON state, all instruments, control devices and circuits can operate.

Note: If the ignition switch is still placed in ACC or ON position after the motor is turned off, the battery power will be drained. The vehicle may be unable to start if the battery power drain time is too long.

START - green light

This position is used for starting the vehicle. When the motor is turned off, there is a valid remote key in the vehicle and the starting conditions are met, press and release the Start Stop button, and the motor will be started.

Starting conditions:

- The shift knob will be adjusted to N.
- Depress the brake pedal and hold it.

OFF

The motor turns off when the shift knob is switched to this position. When the shift knob is placed in N position, press this switch and the ignition switch will switch to OFF.

Caution
When the vehicle is close to strong radio antenna signals, there may be an interference effect on the remote door lock system and the Start Stop button will not work.

PEPS system

Note: *It applies to vehicles configured with PEPS system.*

Keyless unlocking

When all doors are locked, enter the sensing area with a remote key and press the micro switch on the door handle, the central lock will unlock automatically. After unlocking, turn signal lamps will flash twice. If you do not conduct any of the following operations within 30s after that, the central lock will automatically lock again:

- Open any door
- Shift the power supply position to a non-OFF position
- Operate the central lock to unlock/lock

Note: *It is feasible to unlock doors with the central unlocking button on the remote key. Press the central unlocking button once, and the central lock will unlock automatically.*

Keyless locking

When the driver's door or front passenger door is unlocked, enter the sensing area with a remote key, and then press the micro switch on the door handle. The direction indicators will flash once, meanwhile the alarm horn will ring once for a short time (as appropriate). Then all doors will be locked, meanwhile the vehicle enters the fortification state. In any of the following cases, the doors will not be locked after the micro switch is pressed:

- The power supply switch is placed in non-OFF position
- The remote key is left in the vehicle
- The remote key is not in the sensing range
- The remote key battery is low
- The driver's door is open

Note: *It is feasible to lock doors with the central locking button on the remote key. Press the central locking button once, and the central lock will lock automatically.*

Starting and Driving

Keyless start

When the remote key is left in the vehicle and the starting conditions are met, press the ignition switch once at this time, and then the vehicle will be started.

Starting conditions:

- Place the shift knob in N position.
- Depress the brake pedal and hold it.

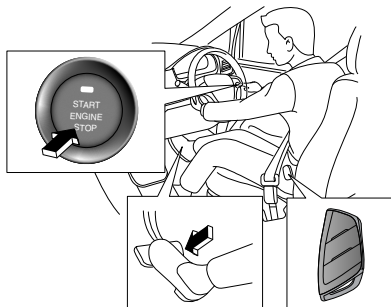

Note: If the starting conditions are not met, every time you press the ignition switch, the power supply positions will be switched among OFF, ACC, ON in a cycle. If the remote key is not in the vehicle, after depressing the brake pedal, the indicator will not go on; the power supply position switching or ignition action will not be performed after the ignition switch is pressed.

Backup starting

When the remote control battery is low, the keyless entry function will fail, but you still can start the vehicle. Open a door with the mechanical key and enter the vehicle. At this time, the system may be in IMMO state and the alarm may be triggered, which is a normal situation.

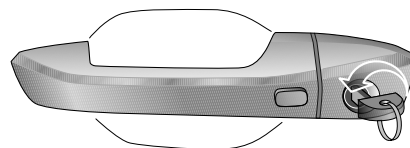

On the premise of meeting starting conditions, lay the key flat in the position with an identification in the storage box which is in front of the central armrest and press the ignition switch. Then the vehicle can be started.

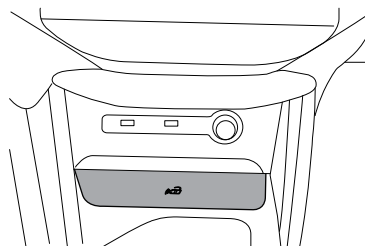

Starting and Driving

Emergency flameout

If you need to shut down the vehicle immediately during driving due to an emergency, please press the ignition switch three times within 3 seconds.

Starting/Stopping

Starting

Place the shift knob in N position.

Depress the brake pedal and hold it.

The key will be adjusted to the "START" position, the vehicle will be started. After the motor starts to operate, the key will be immediately loosened; ignition switch will be automatically switched over to the "ON" position.

For vehicles equipped with the PEPS system, please refer to "Ignition Switch" and "Keyless Start System" in this section.

Caution
The "READY indicator lamp (green)" on the instrument cluster is used to indicate that the vehicle is ready for running. After the vehicle is started, the "READY indicator lamp (green)" will be lit and this lamp will not go out in the running process.

Stopping

The ignition switch will be adjusted to "OFF" position from "ON" position to stop the motor.

For vehicles equipped with the PEPS system, please refer to "Ignition Switch" and "Keyless Start System" in this section.

Pull up the parking brake handle.

Starting and Driving

Driving

 **When driving, never place any portable container with fuel on the vehicle. Otherwise it may leak and a fire may result.**

When driving on a risky road covered with water, snow, ice, mud, sand, etc., please:

- Slow down, drive with care and reserve longer brake distance.
- Avoid any sudden operation during braking, steering or acceleration.
- Apply sand or other anti-skid material under the drive wheels or install tire chains on them to provide the traction needed when the vehicle gets stuck in ice, snow or mud.

Skid

If your vehicle skids on a wet road, you cannot control the vehicle due to the decrease of friction force between the road and tires. Different road surfaces, tire inflating pressures and vehicle speeds may lead to skid. Skid is very dangerous.

The optimum method to stop skid is lowering driving speed and keep cautious when you feel the road is wet enough.

Wading driving

In order to avoid damage to your vehicle, when passing a road with gathered water, please:

- Confirm the water depth before the wading driving. The maximum wading depth of the vehicle is 55 cm.
- Do not drive faster than 10 km/h.
- The wave caused by front vehicle and head-on vehicle may exceed the maximum allowed wading depth.
- To avoid damage to your vehicle, please drive away from the flooded road as soon as possible.

 **Water and mud can affect the braking system and lengthen braking distance, leading to an accident!**

- **Slightly depress the brake pedal to keep brake parts dry and recover performance.**
- **Do not conduct an emergency brake when passing a slippery road.**

Note: The motor, high-voltage battery pack, drive system and electronic system of the vehicle may be severely damaged after the vehicle drives on a road with gathered water. Salt water is corrosive. The on-board components soaked by salt water must be washed with clean water.

Gear shifting

! Situation of the mass surrounding the vehicle especially children must be checked before adjusting to D (drive) or R (reverse) gear. Before leaving the driver's seat, you must confirm that the shift knob is at the N (neutral) position; then, the parking brake will be set and the motor will be turned off.

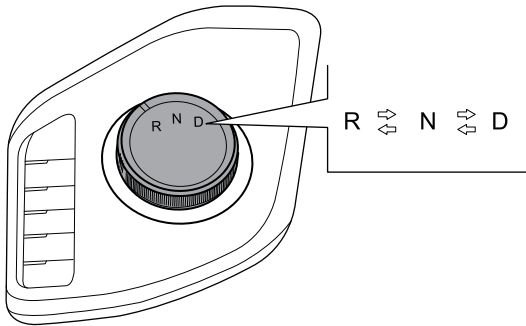

Rotate the shift knob to shift between R (Reverse), N (Neutral) and D (Drive) gears, depress the brake pedal by changing from N (Neutral) to D (Drive) or R (Reverse) position.

R (Reverse gear)

! Completely stop the vehicle before shifting to/out of R (reverse) gear.

This gear will be used to back off.

Depress the brake pedal when shifting to R (reverse) gear. If not, "R" will be displayed on the instrument cluster, indicating "Apply the brakes to shift gears".

N (Neutral & Park gear)

The vehicle must be completely stopped before adjusting to N position. The vehicle will automatically slip even on small slope, unless stamping brake or setting parking brake.

D (Drive gear)

It is the position of forward gear.

Caution

The speed of the motor cannot be increased when the brake pedal is being pressed to adjust to R (reverse) gear or D (drive) gear. You will use brake or parking brake when the vehicle stops on the slope.

Charging requirement

 Slow charging is generally recommended for the vehicle; frequent use of fast charging should be avoided.

Check will be conducted to confirm whether the inlets and jacks are in good condition or not before charging.

It is recommended that the charging connector should be connected to the charging inlet in the body before operating the charging equipment.

In the process of charging operation, surrounding personnel cannot contact operators, vehicle and power supply equipment.

After charging, turn the power of the charging equipment off first, then disconnect the charging connector from the charging inlet in the vehicle body, and close the charging inlet cover as well as the charging port panel on the body.

When the charging pile breaks down, immediately notify the relevant professional, and the operator cannot handle it without authorization.

Charging can be conducted in rainy days, but rainproof measures will be adopted for charging connector and charging port in the process of removing and inserting charging connector.

 Charging operation need be stopped in extreme weather such as storm.

In the charging process, key cannot be inserted for starting. It is strictly forbidden to charge when there is a person in the vehicle.

Do not conduct fast charging and slow charging simultaneously.

Requirements for charging equipment

Requirements for battery charger

- Insulation resistance $\geq 10M\Omega$.
- Low voltage auxiliary power supply of battery charger is between 15A and 20A.
- As low-voltage platform of the vehicle is 12V, charging pile whose low voltage output is 12V will be used for charging to avoid damaging low voltage equipment of vehicle.
- The high voltage output of the charger is greater than 410V.

Special requirements

- The charging equipment must meet Standard IEC 62196.

Safety instructions for charging with residential electricity

Basic principles

- Charging pile is not provided for charging with residential electricity. For charging piles purchased by customers themselves, it is recommended being installed by professionals.
- When charging from a household outlet, avoid using other electrical equipment on the same power line.
- Power supply circuit at the customer side shall be evaluated by qualified professionals.

Requirements for electricity leakage protection device

- Electricity leakage protection device shall be used on the power supply circuit at the customer side, and installed at the frontmost end of the power supply circuit.
- High-sensitivity high-speed electricity leakage protection devices with a sensitive current of 30mA or smaller leakage current value are recommended.

Requirements for over-current protector (air switch)

- Over-current protector must be installed on the power supply circuit, behind and close to the electricity leakage protection device.

Starting and Driving

Requirements for circuit cable

- Power supply circuit at the customer side must be a special circuit, and circuit wiring shall conform to the related requirements for building and electricity.
- For old buildings, it is recommended arranging new special circuit.
- The diameter of power supply circuit cable at the customer side shall be no less than 4 mm² and the total length of cable shall be no more than 50 m.
- Circuit wiring shall avoid the humid or water logged area and be free of flammable substances around.

Requirements for household socket outlet

- Socket must be arranged in positions convenient for vehicle parking and charging operation.
- Standard 220V/13A (Users in British standard area) or 220V/16A (Users in German standard area) AC power sockets are recommended.
- The wiring of the socket should be correct (live wire, neutral wire and earth wire), and the earth wire should be reliably earthed.
- Transfers using adapters, reels, power strips, etc. are prohibited.
- The socket must be protected from rain, sun and foreign objects, and there is no heat source around.
- The socket shall conform to the requirements of IEC 60884, and be reliable in quality.

Miscellaneous

- After the battery is fully charged, disconnect the charging cable; if it is needed to actively stop the charging, first disconnect the charging connector from the vehicle, and remove the plug at the power supply side.
- During charging operation in rainy days, rain shall be avoided from entering the charging connector and inlet.
- Check the connector/inlet for deformation, blackening or ablation before each charge, and replace it immediately if any abnormal condition is found. Even if there is no abnormal condition, if it is used for over 3 years, replace it with a new one.
- If there is peculiar smell, smoking, overheating or other abnormal conditions during charging, immediately turn off the charging circuit, stop the charging operation and check the connector and inlet.
- If the over-temperature fault lamp for charging cable illuminates, check the connector/inlet for deformation, blackening or ablation, and replace it immediately if any abnormal condition is found.

Requirements for charging environment

- Spark may be generated in some modules of charging equipment. To avoid accident, do not conduct charging operation in gas station and places where there are inflammable gases or liquid.
- Charging operation time will be affected by external temperature. Charging time will be extended at low temperatures.

Influence of charging operation on special personnel

When conducting fast charging, the operation area may have magnetic field interference. It is recommended that users who carry implantable heart pacemaker and implantable angiocardy defibrillator keep away from vehicles under charging.

Magnetic field interference may affect normal effect of electronic medical equipment such as implantable heart pacemaker and implantable angiocardy defibrillator. Users who carry implantable heart pacemaker and implantable angiocardy defibrillator may be injured or die.

If you carry implantable heart pacemaker and implantable angiocardy defibrillator, please guarantee when vehicle is under charging operation:

- Don't stay in the vehicle.
- Don't enter into the vehicle for taking objects in the passenger compartment.
- Don't open the tail gate or enter into the vehicle for taking objects at the tail gate.

Note: *When the vehicle does not conduct charging operation, special personnel can ride and drive vehicles.*

Starting and Driving

Charging mode

Charging pile DC charging (fast charging)

Use the public DC charging piles to charge your vehicle.

Please refer to the following table and attached drawings. The **K** label on the vehicle charging port indicates that the vehicle supports the fast charging shown in the following table.

Household single-phase AC charging (slow charging)

Connect the vehicle to a household standard household socket to charge the vehicle, if the socket is not well grounded, the charging device will have a failure prompt for unable to charge. You need to contact a professional electrician to repair the ground wire or connect it to a well-grounded socket for charging. Check the power socket in the process of charging. If it is hot, do not continue to use it. Contact a qualified electrician for servicing the power socket.

Always use the standard household socket which meets the provisions in IEC 60884 for charging.

If a 'Electric Leakage' prompt is displayed, contact a professional electrician to check the insulation status of the hot wire or the neutral wire.

Special power sockets should be selected for battery charging, as they can prevent line damage and protection trip caused by high-power charging from affecting the normal use of other equipment. Over time, the power socket may wear out due to

normal use and may even be damaged, making it no longer suitable for charging an electric vehicle.

When used outdoors, plug it into a power socket that is protected from rain.

Charging pile AC charging (slow charging)

Use the public AC charging piles to charge your vehicle.

Please refer to the following table and attached drawings. The **C** label on the vehicle charging port indicates that the vehicle supports the slow charging shown in the following table.

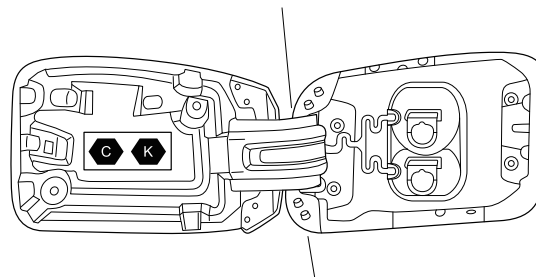

Configuration	Type of accessory	Voltage range	Identifier
TYPE 2	Vehicle inlet	≤480V RMS	C
FF	Vehicle inlet	50V ~ 500V	K

Fast charging

Note: *Fast charging should be conducted by the personnel in the fast charging station according to the operation instructions for charging pile.*

To perform a fast charging for the vehicle, turn the power switch off, remove the key, wait for 3 ~ 5 minutes, and then follow the instructions below:

- 1 Select a standard DC charging connector that matches your vehicle.
- 2 Open the charging port door opening switch  on the driver's door, unlock the charging port door from the vehicle, and open the charging port door to the maximum position.

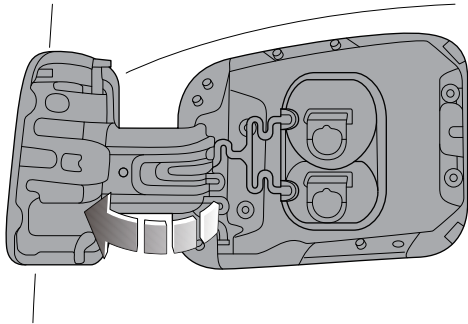

- 3 Open the cover on the charging inlet.

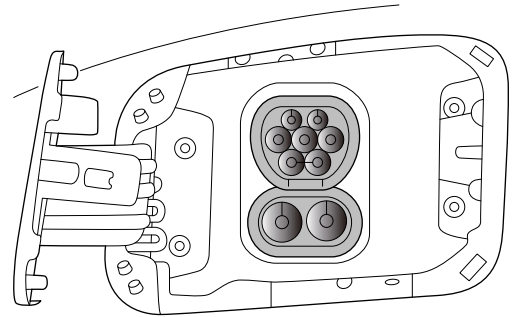

- 4 Remove the DC charging connector from the charging pile.
- 5 Connect the charging connector with the charging socket, and lock the connection of the charging connector and charging socket using the locking mechanism on the charging connector handle.
- 6 Connect the charging connector to the charging equipment, and turn the power of the charging equipment on according to the instructions on the charging pile.

Note: *Before charging, check whether there is any abnormality in the charging equipment. In the charging process, the "charging status indicator (yellow)" on the instrument cluster illuminates. If the equipment can not be charged after 3 consecutive attempts, it is recommended to replace other equipment for attempts.*

Starting and Driving

If the equipment can be charged after replacement, the previous charging equipment may be damaged.

Note: Please check whether the PP and CP pins of the charging connector are rusted. If so, please clean them before charging to prevent charging failure.

- 7 After the charging connector is properly connected, the "charging connection indicator (red)" on the instrument cluster will come on.

Note: Please make sure that the charging connector is fully inserted into the charging stand to avoid that the electronic lock cannot be locked, resulting in charging failure, as shown below.

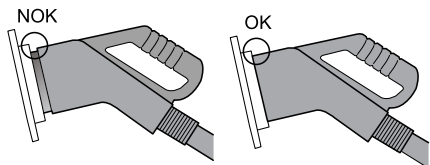

- 8 In the charging process, the "charging status indicator (yellow)" on the instrument cluster illuminates.

- 9 Upon completion of charging, the "charging status indicator (yellow)" goes out. Please turn the power of the charging equipment off before removing the charging connector.

- 10 Close the cover on the charging inlet.

- 11 Close the charging port panel.

Caution

Select a standard DC charging pile or charging equipment that matches your vehicle. Once the battery is fully charged, the battery management system will have an automatic calibration function. If the vehicle has been shallowly charged (less than 99%) every two or three times, you need to fully charge (100%) the vehicle once.

Slow charging

There are three ways to slow charge. The charging method on your vehicle depends on the actual configuration of your vehicle.

- 1 Mode 2 charging is shown in the figure below. One end of the charging in this mode is connected to the household socket and the other end is connected to the vehicle. (This connector is optional for users)

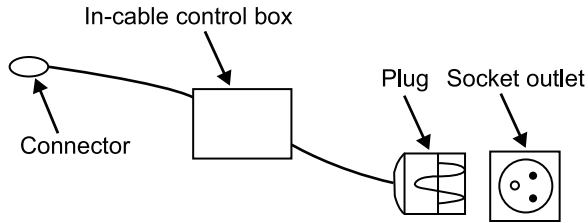

The LED words on the In-cable control box are as follows:

Charging status	Status description			
	Power (Green)	Charging (Red)	Fault (Red)	Complete (Green)
Initial state	On	Flash	Flash	Flash
To be connected	On	On	Off	Off
Normal charging	On	Off	Off	On
Charging completed	On	Off	Off	On

Power-on self-test failed	On	Off	Flash	Off
Abnormal communication	On	On	Flash	Off
Over/under voltage	On	Off	On	Off
Ungrounded	On	Off	On	Flash
Over current	On	Flash	On	Off
Current leakage	On	Off	Flash	Flash
Over temperature	On	On	On	On

- 2 Mode 3 charging is shown in the figure below. One end of the charging in this mode is connected to the charging piles and the other end is connected to the vehicle. (This connector is optional for users)

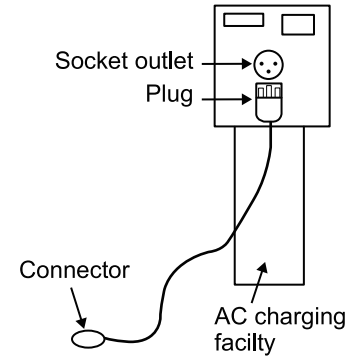

Starting and Driving

3 Direct charging with charging post.

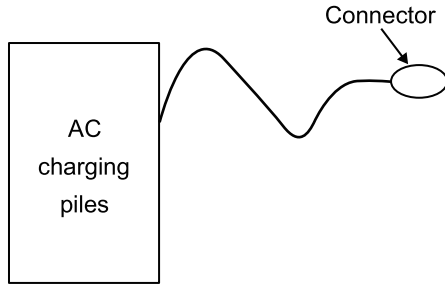

Note: Slow charging is a way of charging high-voltage battery pack to reach the optimal equilibrium state.

To perform a slow charging for the vehicle, turn the power switch off, remove the key, wait for 3 ~ 5 minutes, and then follow the instructions below:

- 1 Select the standard 13A socket (British standard socket) or 16A socket (German standard socket) with reliable earthing or AC charging piles.
 - British standard socket.

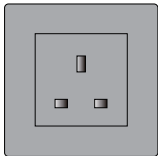

- German standard socket.

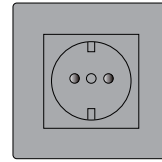

- 2 Take the charging connector out from its package.
- 3 Insert the AC input cable plug of the charging connector into the socket or AC charging piles.
- 4 Open the charging port door opening switch  on the driver's door, unlock the charging port door from the vehicle, and open the charging port door to the maximum position.

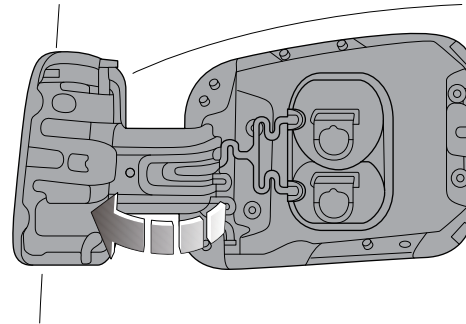

Starting and Driving

- 5 Open the cover on the charging inlet.

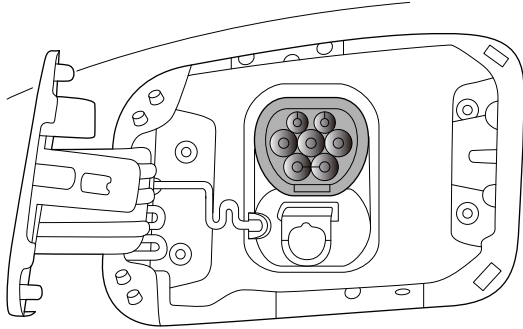

- 6 Connect the charging connector to the charging inlet.

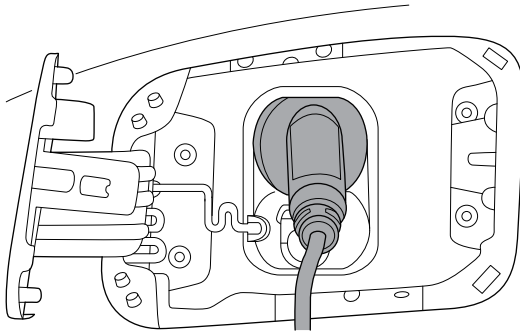

- 7 After the charging connector is properly connected, the "charging connection indicator (red)" on the instrument cluster comes on and the electronic lock of the charging inlet is enabled, which guarantees that the charging connector will not be unplugged whilst charging.

Note: Please make sure that the charging connector is fully inserted into the charging stand to avoid that the electronic lock cannot be locked, resulting in charging failure.

- 8 After the above operations are completed, the system will be charged automatically within about 20 seconds.
- 9 During charging, the "charging status indicator (yellow)" on the instrument cluster is on.

Note: After charging is finished, the key will be locked again if the connector is not pulled out. If the key is switch on the position run, you need to be unlocked through the central control.

Note: If charging with a public AC charging pile, connect the charging connector to the charging equipment, and charge according to the instructions on the AC charging pile.

Note: If charging with a public AC charging pile, before charging, check whether there is any abnormality in the charging equipment. In the charging process, the "charging status indicator (yellow)" on the instrument cluster illuminates. If the equipment can't be charged

Starting and Driving

after 3 consecutive attempts, it is recommended to replace other equipment for attempts. If the equipment can be charged after replacement, the previous charging equipment may be damaged.

Note: *If charging with a public AC charging pile, please check whether the PP and CP pins of the charging connector are rusted. If so, please clean them before charging to prevent charging failure.*

- 10 Once the battery is fully charged, the "charging status indicator (yellow)" on the instrument cluster will go out, and the electronic lock of the charging socket will be unlocked automatically. Press the button switch on the charging connector to remove the charging connector.

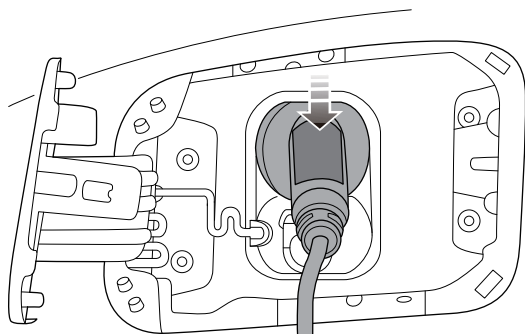

Note: *If it is required to end the charging in advance and remove the charging connector, unlock the vehicle with*

a smart key or an ordinary key, and the electronic lock of the charging interface will be automatically unlocked. Press the button switch on the charging connector to remove the charging connector (If the charging connector is not removed in 27 seconds, the electronic lock of the charging interface will be locked again), and finally turn the ignition switch back to the Lock position.

- 11 Close the cover on the charging inlet.
12 Close the charging port panel.
13 Stow the charging connector in its package.

Caution

Emergency treatment: In the event of an emergency such as fire, smoke or burnt smell, turn the socket power switch off immediately to completely power off the system. If the vehicle has been shallowly charged (less than 99%) every two or three times, you need to fully charge (100%) the vehicle once.

Starting and Driving

Caution

- If any unidentified foreign matters are found in the charging plug, insulator, pin and socket, the charging process shall be terminated immediately.
- It is strictly prohibited to insert the charging plug and charging base obliquely.
- It is strictly prohibited to shake the charging plug up, down, left and right when inserting / pulling it out, and it must be inserted / pulled out with vertical force.
- During charging, the cable of charging plug must be smoothed, and it is not allowed to distort to force the charging connector seat during use.
- During the charging process, in case of extremely severe weather such as typhoon, rainstorm and hail, the charging process shall be terminated immediately.
- During the charging process, if the charging interface continuously emits strong and irritating odor, the charging process shall be terminated immediately.

Charging inlet emergency cable

The AC charging inlet has an electronic lock function, which prevents children from touching or accidental unplugging of the charging connector in the process of charging. After the charging connector is inserted into the AC charging inlet, the electronic lock in the charging inlet locks along with the main control switch of the vehicle. Do not force the charging connector out, or it may cause damage to the vehicle. The charging connector can only be pulled out after the vehicle is unlocked using the key or the main control switch. If the key or the main control switch cannot be used to unlock the charging connector, you may pull out the emergency cable located under the rear left seat to unlock the charging connector.

2

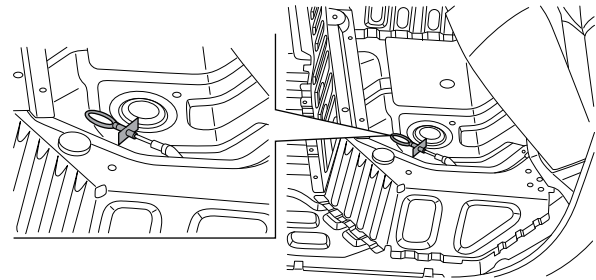

Starting and Driving

Charging information

Rated charging voltage	Charging power	Charging stand standard	Slow charging standard	Fast charging standard	Anti theft of slow charging connector
401.5V	Max. 88.55kWh(80.3kW)	CCS2	IEC61851	DIN70121	Anti theft

Equalizing charge

Equalizing charge means the battery management system realizes basically the same voltage of all battery cells after charging, so as to ensure the whole performance of the high-voltage battery pack. It is recommended using the vehicle at least once a month. It is also recommended conducting over-10h slow charging for the vehicle every month to extend the service life of high-voltage battery pack.

Charging time

Charging time of high-voltage battery pack is related to many factors, such as current electric quantity, charging mode, ambient temperature and charging device power.

Fast charging time

Under the normal temperature state, if the charging equipment has an output capacity of over 105 kW, it will take approx. 45 minutes to charge the high-voltage battery from 20% to 80%.

- About 45 minutes (applicable to models equipped with 88.55kWh high-voltage battery pack)

Caution

- At a low temperature and in an extremely high temperature environment, the required charging time will be extended.
- If the output capacity of charging device is insufficient, the required charging time will be extended.

Note: *In order to protect the high voltage-battery pack and to speed up the temperature rise of the battery, when performing a fast charge in a low temperature environment, the high voltage-battery pack may have a drop in capacity for a short period of time, it is normal.*

Slow charging time

Under the normal temperature state, from the alarm state (the low high-voltage battery pack warning lamp on the instrument cluster illuminates) to the full charge state, depending on the different high-voltage battery pack configurations and charging method, it is divided into the following types:

- About 9.5 hours (applicable to models equipped with 88.55kWh high-voltage battery pack which perform three-phase AC charging at normal temperature)
- About 15 hours (applicable to models equipped with 88.55kWh high-voltage battery pack which perform single-phase AC charging at normal temperature)

Caution

- At a low temperature, the required charging time will be extended.
- If equalizing charge has not been conducted for a long time, the required charging time will be extended.
- Equalizing charge shall be conducted before the first use of long-time parked vehicle, and the charging time shall be appropriately extended to complete the equalizing charge.

Note: *The slow charging time mentioned above means the time required by the vehicle to use AC charging pile for charging. When the residential electricity is used for charging, corresponding charging time will be about 2.5 times of that required for adopting AC charging pile.*

Acoustic vehicle alerting system (AVAS)

Battery electric vehicles are quieter when driven at low speeds, resulting in a higher probability of traffic accidents with pedestrians (especially blind people) than with conventional cars. The acoustic vehicle alerting system (AVAS) can emit warning tones or beeps at low speeds, helping reduce the probability of traffic accidents with pedestrians.

The balance between ensuring safety and reducing noise pollution is achieved through audible warning and sound effect design for different groups of people with different sound sensitivity.

Acoustic vehicle alerting system (AVAS) sound effect

When the vehicle travels at a speed of 0 to 20 km/h, the AVAS will simulate the sound of engine running and give out an audible warning. The warning tone gradually increases as the vehicle speeds up and decreases as the vehicle slows down, thereby reminding people outside that the vehicle is passing by. The minimum average frequency shift speed of this frequency meets $\geq 0.8\% / (\text{km/h})$.

Note: When the vehicle travels at 0 km/h, the AVAS will not give a warning sound.

When reversing, the AVAS will emit an audible warning that simulates the sound of engine running to remind people outside that the vehicle is reversing. The warning tone increases as the vehicle speeds up and decreases as the vehicle slows down.

Note: When the vehicle is reversed at 0 km/h, the AVAS will not give a warning sound.

Electric power steering unit

 **If the electric power steering fails or cannot operate, the steering will appear very heavy, which will affect driving safety.**

The electric power steering system only works when the vehicle is starting. The system operates via a motor with assistance levels automatically adjusted based on vehicle speed, steering torque and steering wheel angle.

The electric power steering system has the advantages of simple structure and energy saving. Compared with the traditional hydraulic power steering system, the electric power steering system only needs energy in actual steering, so that power loss can be reduced in this operating way of power consumption according to the need.

Note: When the electric power steering system operates, holding the steering wheel on full lock for long periods will result in a reduction in power assistance and cause a heavier feel to the steering.

EPS (Electric Power Steering) system MIL

See "Warning lights and indicators" in Before You Drive section. If the battery is disconnected or lacks power seriously, this light may illuminate. At this point, fully turn the steering wheel to the left then the right, thus the system initialization is completed, and the light will go out.

Brake system

Service brake

Dual brake hydraulic system

 **A failure in one of the hydraulic pipelines will be indicated by illumination of the "braking system**

warning light (red)"  on the instrument cluster while driving; it will result in increased brake pedal travel and effort, longer braking distance and may cause the vehicle to pull to one side. Do not pump the brake pedal in an attempt to restore pedal pressure. If there is pressure failure in one of the brake pipelines, the cause must be investigated. IMMEDIATELY bring the vehicle carefully to a halt. You should contact Our Service Dealer immediately. Do NOT continue driving.

Should one of the hydraulic pipelines fail the other circuit will continue to function.

Starting and Driving

General state

 Always ensure that floor mats or other objects do not disturb brake pedal movement.

Never rest your foot on the brake pedal as this may overheat the brakes, reduce their efficiency and cause excessive wear. If brake pads/shoes have worn excessively, a squealing or screeching noise will be heard when the brakes are applied, and braking efficiency will be affected. Contact Our Service Dealer for service as soon as possible.

If the motor stops running due to some causes, brake booster will stop working after 2 pedal operations; to achieve the expected brake effect, a larger force shall be applied on the pedal. In these circumstances the braking distance may be longer.

If the vehicle is not in regular use or is garaged for long periods, the efficiency of the braking system could be impaired. Contact Our Service Dealer for service as soon as possible.

Wet state

 Driving in heavy rain and slushy roads will considerably reduce braking efficiency. At this time, keep safe distance from other vehicles and gently depress the brake pedal intermittently to dry the brake friction components. In severe wet weather, this drying process may need to be repeated every few miles.

In winter, ice can form or salt may accumulate on the brake pads and discs. Ice and salt accumulation will be cleaned off after intermittently light applications of the brake pedal.

Descending steep hills

 Overheating the brakes will reduce braking efficiency and may also cause the vehicle to pull to one side.

ABS (Anti-lock Braking System)

ABS is used to prevent the road wheels from locking under emergency braking, thereby helping you maintain steering control. No special driving technique is needed.

Under normal braking (where sufficient road surface friction exists to prevent wheel lock), the ABS will not be activated.

An integral feature of this braking system is Electronic Brake Distribution (EBD), which is used to optimize the braking force at the rear wheels under full load condition.

ABS function



ABS may not be able to shorten the brake distance, depending on road surface conditions, brake distance may vary significantly. In fact, when the vehicle without ABS drives on some roads (e.g., gravel road or snowy road), the brake distance may be shorter.

ABS cannot overcome the physical limitations of stopping your vehicle in too short a distance, cornering at high speed, or aquaplaning, i.e. where a layer of water prevents adequate contact between the tires and the road surface.

ABS can better protect yourself and other road users from unnecessary risks. You still have a duty to drive within normal safety margins, having due considerations for the road surface, weather and traffic conditions.

If the braking force you use exceeds the available adhesion between the tires and the road, causing one or more wheels to be locked, then ABS will automatically come into operation. You will hear the sound of a rapid pulsation which will also be felt through the brake pedal.

Even when making emergency braking on a slippery road surface, be sure to depress the clutch pedal and fully depress the brake pedal. ABS is activated; it constantly monitors the

Starting and Driving

speed of each wheel and varies the braking pressure to each according to the amount of friction available.

This prevents the wheels from locking and enables steering control to be maintained.

Precautions for driving a vehicle with ABS

- In case of emergency braking, for vehicles equipped with manual transmission, depress the clutch pedal, meanwhile fully depress the brake pedal; for vehicles equipped with automatic transmission, fully depress the brake pedal.
- Under normal braking, apply steady pressure to the brake pedal - DO NOT PUMP IT.
- Remember that steering control will always be available during braking.
- The availability of ABS does not eliminate the dangers of driving too close to the vehicle in front, aquaplaning, excessive cornering speeds, etc.
- ABS does NOT guarantee shorter braking distances.
- Do not be alarmed if you hear and feel a pulsing at the brake pedal. This is normal and indicates that the ABS is in operation.

ESC (Electronic Stability Control)

Functions of ESC

ESC covers the functions of ABS, EBD, TCS, VDC, EBA, RMI, HHC and HDC.

ESC indicator on the instrument cluster flashes when the ESC is operating. You may hear some noise or feel the vibration of brake pedal, which is normal.

When the ignition switch is placed in "ON" position, "ESC

indicator (yellow)"  will illuminate and go off after several seconds. In normal driving conditions, ESC indicator keeps off, and ESC is in monitoring state. When the ESC indicator flashes, it indicates ESC is operating. You may hear some noise or feel the vibration of brake pedal, which is a normal phenomenon. In case of ESC failure, ESC indicator will stay On. Please take the vehicle to Our Service Dealer for ESC inspection.

ESC can be turned off with ESC OFF button, and when ESC

function is turned off, "ESC OFF indicator (yellow)"  illuminates and only ABS and EBD functions are available.

Starting and Driving

EBD (Electronic Brake-force Distribution)

EBD automatically detects the grip conditions between wheels and ground, distributes the brake force optimally to 4 wheels, so as to improve brake efficiency and driving stability.

TCS (Traction Control System)

TCS automatically controls the driving force at the start-off and acceleration to prevent wheels from spinning, so as to maintain the driving stability.

VDC (Vehicle Dynamics Control)

VDC is an advanced computer system, which can help you to control the vehicle driving direction in severe driving conditions. When the computer detects the deviation between the expected driving route and the actual driving direction, VDC system may selectively apply brake pressure on one or more brakes of the vehicle so as to keep the vehicle driving in the direction commanded.

EBA (Electronic Brake Assist)

In case of an emergency, the force applied by a driver on the brake pedal is usually insufficient. EBA can identify this rapid action with insufficient force on the brake pedal and automatically establishes a brake pressure up to the lock level to shorten the brake distance greatly.

RMI (Roll Movement Intervention)

RMI can identify the vehicle rollover trend as early as possible by monitoring the turning angle of steering wheel and lateral acceleration, and apply braking to one or more wheels to prevent the rollover to the greatest extent.

HHC hill hold control

When the vehicle drives uphill, HHC can prevent the vehicle from sliding backwards after the driver releases the brake pedal. The driver has up to 2s (for AT models) or 3s (for MT models) to move his foot from the brake pedal to the accelerator pedal for hill-start.

Starting and Driving



HDC (Hill Descent Control)

When driving on a long downhill road with a relatively great gradient, if the vehicle speed is within a certain speed range, there is no need for the driver to depress the brake pedal and accelerator pedal, and the vehicle will run at a low speed automatically, so as to ensure the vehicle goes downhill steadily; at this time, the driver can correct the automatically controlled speed of system through brake pedal and accelerator pedal.

When the vehicle speed is within the range of 35 ~ 60 km/h, HDC is inoperative but in standby state.

When the vehicle speed is greater than 60 km/h, HDC function automatically exits, and when it is reactivated, it is required to press the HDC switch  again.

When the ignition switch is placed in "ON" position, HDC is in off state by default, and other functions of ESC are all in standby state. When the HDC switch  is turned on, "HDC indicator

(yellow)"  in the instrument cluster illuminates, and HDC function is in monitoring state. At this time, if HDC operates, "HDC indicator (yellow)" will flash; if "HDC indicator (yellow)" goes off, When the HDC switch  is turned on, it indicates a HDC failure. Please take the vehicle to Our Service Dealer for ESC inspection. When the HDC switch is turned off, "HDC indicator (yellow)" in the instrument cluster goes off, and HDC function is disabled at this time.

Note: *HDC function is used to assist the driver to go downhill steadily at a low speed, and it is not recommended to enable this function on a non-ramp road.*

Precautions for driving a vehicle with ESC

ESC can detect and analyze vehicle conditions, and take preventive measures by correcting wrong driving operation. However, anything has its limit and no safety device is absolutely safe if the driver blindly drives the vehicle over-speeding.

Manual parking brake

Pull up parking brake handle.

- Depress the brake pedal all the way down to make a full stop.
- Pull up the parking brake handle with effort.
- Release the brake pedal and ensure the vehicle is already in stationary state.
- If the vehicle still moves, pull up the parking brake handle with greater effort.

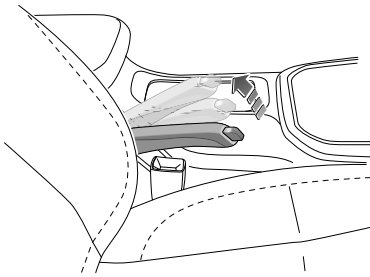

When the ignition switch is placed in "ON" position, pull up the parking brake handle, and "brake system warning light (red)"



in the instrument cluster will illuminate.

Ramp parking

When parking uphill, turn the front wheels away from the curb.
When parking downhill, turn the front wheels to the curb.

Release the parking brake handle

⚠ Before the ignition switch is turned on, do not release the parking brake handle. Otherwise vehicle may slip backwards, and the vehicle can not make a hill start. Before driving, ensure the parking brake handle has been fully released, and "brake system warning light (red)" in the instrument cluster has gone out, because partial braking may lead to overheat, efficiency reduction and excessive wear of rear brakes and even an accident.

Slightly pull up the parking brake handle, then press the button at the end of lever, and push the handle fully down.

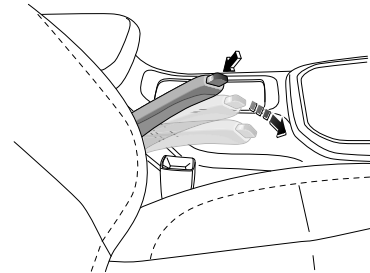

Starting and Driving

Warning Light

Warning lights related to brake system include "brake system warning light (red)", "ABS warning light (yellow)", "EBD warning light (red)", "ESC indicator (yellow)", "ESC OFF indicator (yellow)" and "HDC indicator (green)", please see "Warning lights and indicators" in Before You Drive section.

Parking assist system

Note: *The type of parking assist system equipped on your vehicle is subject to the actual vehicle configuration purchased.*

Parking sensor

 The parking assist system is not always reliable and is only playing the role of guidance! The parking sensors might not detect some types of obstacles, including slim objects (such as wire nets and ropes), small objects close to the ground, conic objects and some objects with non-reflective surfaces.

The parking sensors shall be free of dirt, ice, and snow. The sediment on surfaces of parking sensors will impair the normal functioning of the sensors. Therefore, avoid directly flushing the parking sensors from a short distance by a high pressure water gun while washing your vehicle.

Two parking sensors installed on the rear bumper will scan the rear area of vehicle, in order to judge the presence of obstacles. Upon detection of any obstacle, the parking sensors will calculate its spacing from the rear of the vehicle and send the information to the driver by alerting tones. It's really important that this system is only a parking assist system and can't function as the replacement for your observation and personal judgment.

Starting and Driving

Working status of parking sensor assist system

After shifting into the reverse gear, the parking assist system will give out a short prompt tone to indicate the operation started automatically. When selecting other gears, the parking assist system will stop working.

Note: If the system gives out a long prompt tone after the gear is shifted to "R", it indicates that the system has a malfunction. Contact Our Service Dealer for service as soon as possible.

When reversing the vehicle:

When the vehicle is at about 150 cm distance from the rear barrier, the system will start making alarm sounds. And the alarm sound become harsher when the vehicle is approaching the barrier.

When the distance of the vehicle from the rear barrier is less than 40 cm, the system will produce a long alarm sound. At this moment, it is impossible to effectively identify the barrier if you continue to reverse the vehicle.

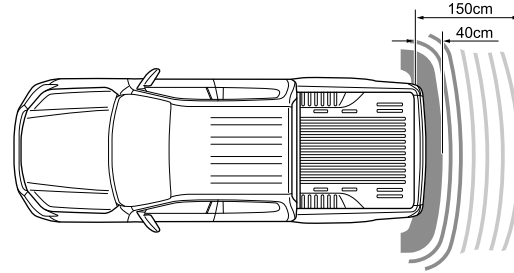

Starting and Driving

Parking camera

! The parking camera assist system is not always reliable and is only playing the role of guidance! Due to limited visual field, the parking camera can't detect any obstacle beyond its visual field.

Working status of parking camera assist system

After shifting the gear to R, the image of entertainment system display screen will be switched to the reverse camera operating state, and the entertainment system display will show the scene image behind the vehicle for the driver's reference during reversing.

When you place the shift knob in other positions, the reverse camera parking assist system will stop operating, and the entertainment system display screen will recover to the pre-reversing state.

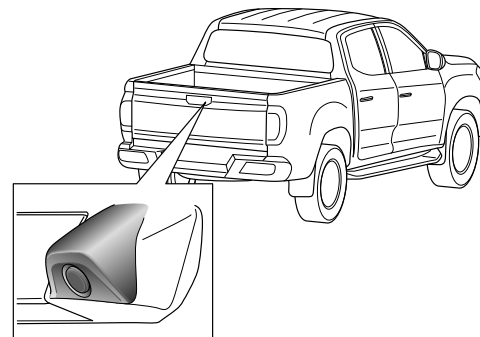

Note: When the vehicle enters the reversing state, cameras will output static reversing tracks which are displayed on the entertainment system display, take the horizontal plane as reference, and identify the area behind the vehicle in segments divided by red, yellow and green lines.

Tires



DEFECTIVE TIRES ARE DANGEROUS!

Do NOT drive your vehicle if any tire is excessively worn, damaged or inflated to an incorrect pressure.

Do NOT overload vehicle.

Incorrect tire inflation pressures or an unbalanced wheel and tire assembly can seriously affect the stability, especially when driving with high payloads or at high speeds. Under-inflation will increase rolling resistance and accelerate tire wear, resulting in tire damage, even an accident.

Always drive with consideration for the condition of the tires; the most common causes of tire failure are:

- Bumping against curbs.
- Driving over deep pot holes.
- Tire under-inflation or pressure overload during driving.

Uneven tread wear can be caused by faulty wheel alignment.

Winter tires



The vehicle speed shall not exceed the maximum allowable speed of the installed winter tires, otherwise the tires may suddenly lose pressure, delaminate, or even burst, which may easily cause accidents!

Be sure to adjust the speed according to the specific climate, roads and traffic conditions. Do not take risks by taking advantage of the anti-skid performance provided by winter tires and beware accidents!

Winter tires can improve the handling stability and braking performance of the vehicle when driving in a low temperature environment or on icy roads. It is suggested that winter tires should be used when the temperature is lower than 7°C.

When a vehicle is running under winter road conditions, winter tires can greatly improve the handling stability and braking performance. Non-winter tires have poor skid resistance at low temperatures or on icy roads due to their structure (tire width, rubber composition, pattern type, etc.).

Starting and Driving

It is recommended to use winter tires of the same size and load index as that of the original tires, and all the four wheels shall use winter tires.

When the tread depth of winter tires is worn to 4mm, the skid resistance will decrease obviously.

The maximum allowable speed of winter tires shall be subject to the speed code on the tires.

Speed symbol	Maximum speed (km/h)
C	60
D	65
E	70
F	80
G	90
J	100
K	110
L	120
M	130
N	140
P	150
Q	160
R	170
S	180
T	190

Speed symbol	Maximum speed (km/h)
H	210
V	240
W	270
Y	300

When the temperature rises above 7°C, it is recommended to replace winter tires with non-winter tires.

Anti-skid chain

When driving a vehicle in the snow, it is recommended to apply S anti-skid chain to the driving wheels.

The anti-skid chain could increase the traction when driving on roads in winter. If you want to install the anti-skid chain, please remember that:

- 1 Not all wheels and tires are suitable for an anti-skid chain.
When installing anti-skid chains, only approved tire size can be used.
- 2 Install anti-skid chains on the drive wheels. Please follow the instructions of anti-skid chain manufacturer.

It is just in the snow that you can drive the vehicle at maximum speed allowed by the anti-skid chain. Please comply with the regulatory requirements of the resident country. Remove the anti-skid chain immediately when driving on the snow-free road.

Loading

It is the driver's responsibility to ensure no overload in accordance with the laws.

Note: The maximum allowed total mass is indicated on the vehicle identification plate which is located in the lower front of on the B pillar. This Handbook introduces the correct vehicle weight parameters, see "Vehicle weight parameters" in General Technical Parameters section.

Starting and Driving

Load carrying

Goods shall be placed between both axles and neither deviate to the front axle loading area nor the rear axle loading area. Heavier goods shall be distributed evenly, and the heaviest goods shall be placed between both axles.

Caution

During the driving of the vehicle, the tailgate of the container shall not be opened. When the vehicle is stopped, the total weight of people and goods shall be controlled below 200kg when using the tailgate of the container to get on and off and load and unload goods.

Load restraint

! Secure all loads in the vehicle to prevent personal injury due to movement of loads.

Note: *The driver is obliged to ensure all goods have been fixed correctly.*

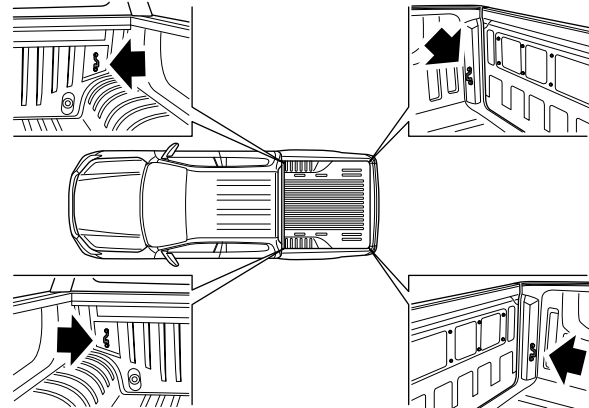

Starting and Driving

Cord hook (strapping ring) in the container can withstand the maximum vertical and 45 ° tensile force of 1500N.

Hazardous loads

There is a legal requirement to display a specific type of external warning sign on the vehicle if certain hazardous goods are being carried.

Roof Rack and Load Device



Be sure to place your luggage properly on the roof rack, otherwise accidents may occur. Under any circumstances, the maximum roof load, maximum axle load or maximum total vehicle load shall not be exceeded, otherwise accidents may occur. The roof rack with loaded items will reduce the vehicle stability, especially during turns and crosswind. When placing heavy or bulky luggage on the roof rack, the centroid position deviation of the vehicle and the wind resistance may affect the vehicle's drivability and cause accidents. Under this circumstances, you should adjust the driving mode and speed according to the actual situation. Off-road driving with items on the roof rack is not recommended.

The drivability of the vehicle may be affected by the loading items. Only the rack system designed for your vehicle can be fitted. Please consult Our Service Dealer for more information.

For the roof rack system of SMC approved by our company, the maximum driving load is 30 kg, and the maximum driving load for other roof rack systems is 50 kg. The weight of the approved rack system is not included in the loading capacity.

If other roof rack system is used, the system's own weight must be included in the loading capacity.

The loading items must be distributed evenly and not suspended on the rack. Check the connection between the rack and the loading items after driving 50 km.

Trailer towing

Note: *It applies to vehicles configured with trailer towing.*

Instructions of trailer towing

The vehicles are designed for use primarily as a passenger and load bearing vehicle. Towing a trailer may create adverse effects on a number of factors including handling, durability, performance and braking. We recommend for the safety of yourself, your passengers and others that the vehicle and trailer is not overloaded.

The warranty does not cover any damages caused by or relating to towing a trailer.

- Weight limits

Establish that gross vehicle weight, trailer tow ball down load, trailer weight and axle weights are all in accordance and not exceeding their individual limits.

- Gross vehicle weight

Please refer to your vehicles data label for reference on what gross vehicle weight must not be exceeded.

Gross vehicle weight is the combined weight total of the trailer towbar, unloaded vehicle, driver, luggage and passengers. This also includes the weight of any accessories or equipment added to the vehicle.

Instructions before use

- The state specific trailer towing regulations must be followed.
- The vehicle speed should not exceed 100 km/h.
- It is only applicable to center axle trailers, and the load specified in "Recommended towing weight" shall not be exceeded when towing trailers.
- When a new vehicle has been driven or a vehicle has had powertrain parts changed to new parts, it is recommended not to tow a trailer until the driving distance reaches 800 km.
- Place the load as close as possible to the trailer axle, fix it securely and place it as low as possible, while ensuring that the towing weight and the load allowed by the tow ball are not exceeded (Refer to "Recommended towing weight" for details). For best stability of the trailer in an unladen vehicle, place the load in the trailer towards the nose within the maximum nose load (Refer to "Recommended towing weight" for details), as this gives the best stability.
- The specified trailer loads are only applicable to an altitude less than 1,000 m. As the air density decreases with the altitude increase, causing the drive motor output and grade ability to drop, the total mass must be reduced by 10% when the altitude increases by 1,000 m.
- The tires of towing vehicle shall be adjusted to the specified pressure, and the pressure of trailer tires shall also be checked, and on the rear tire pressure, at least 20kPa(0.2bar) above the tire pressure as recommended for normal use (i.e. without a trailer attached).

Starting and Driving

- If the traffic conditions behind the trailer are invisible through the standard outside rear view mirrors, two additional rear view mirrors must be installed on the reversible boom and adjusted to ensure sufficient rear view at any time.
- The headlamps shall be checked and adjusted if necessary after a trailer is hitched up.
- Always use a safety chain that is suitable for your vehicle and trailer. Have the safety chain passing through the hole at the lower part of the hitch and attach it to the trailer. The safety chain will prevent the trailer from dropping to the ground in the event that the hitch disengages. For proper use and installation, consult the trailer manufacturer.

Instructions for driving

- Before driving, check all the safety equipment to ensure safe operation. Ensure that the vehicle is properly maintained to avoid mechanical failure.
- Avoid non-loaded towing vehicle and loaded trailer as much as possible when driving. If it is inevitable, drive at low speed due to improper load distribution.
- As the driving stability of towing vehicle and trailer drops with the speed increase, the speed shall be as low as possible without exceeding the specified speed limit under the improper road, weather and strong wind conditions, especially when driving on a slope.
- When the trailer sways, grip the steering wheel firmly to drive straightforward, and release the accelerator pedal to decelerate the vehicle slowly. Do not attempt to eliminate sway by turning the steering wheel or by emergency braking. The higher the speed, the stronger the trailer swaying. If the sway is still not eliminated after deceleration, stop the vehicle to check if the trailer weight distribution is even and the trailer device is installed securely.
- Under any conditions, the vehicle must be decelerated immediately once minor sway is noticed on the trailer, and never try to eliminate the sway through acceleration.
- If an inertia brake is installed on the trailer, first brake slowly and then brake rapidly when braking is required. This can avoid braking impact due to trailer wheel locking.
- Clean, dry and flat concrete or asphalt (or similar) pavement is required for towing.

Starting and Driving

Trailer control module

The trailer control module provides actuation functions for the width lamp, brake lamp, reverse lamp, turn signal lamp and rear fog lamp of the trailer. The trailer control module automatically identifies if a trailer is connected by the trailer detection.

Pull up the parking brake handle and turn off the ignition switch. Connect the trailer; refer to "Installation of Trailer Device" for details. Connect the trailer wiring harness. The harness connection points are as shown below. If the trailer wire harness is required, please contact our Service Dealers.

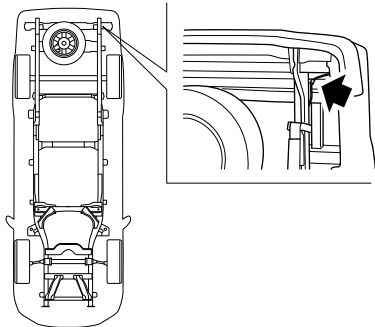

Turn the ignition switch to ON position. When the trailer is connected successfully, when the turn signal lamp is turned

on, "trailer indicator (green)"  on the instrument cluster

flashes. When the trailer connection fails, "trailer indicator (green)" on the instrument cluster goes off.

Caution

- The width lamp, turn signal lamp or both of them on the trailer must be halogen lamp. Otherwise, it may be misjudged that the trailer is not connected, and normal operation of reverse radar system will be affected.
- When the ignition switch is turned to "ON" position, the trailer lamps may flash instantaneously. This is normal as the system is conducting self-check.

2

Starting and Driving

Recommended towing weight

Towing capacity

Without Trailer Brake	With Trailer Brake
750 kg	1,000 kg

Trailer nose weight

Caution

Never exceed the maximum allowable nose weight, for example, the vertical weight on the tow ball. This is important for the vehicle and trailer stability.

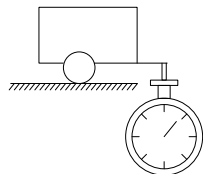

Variant	Maximum Nose Weight
All models	100 kg

Installation of trailer device

Install the trailer device onto the frame. The trailer device shares the same mounting points with the rear bumper bracket. It is required to remove the rear bumper assembly, and install the rear bumper assembly and trailer device together onto the frame, and then tighten the bolts to $87\pm 10\text{Nm}$. If the trailer device is required, please contact our Service Dealers.

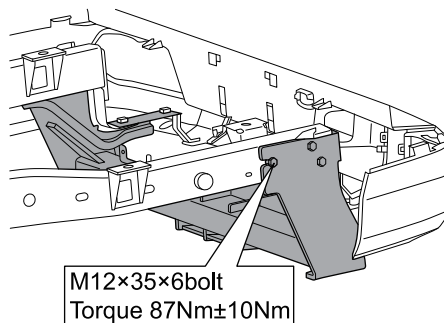

Starting and Driving

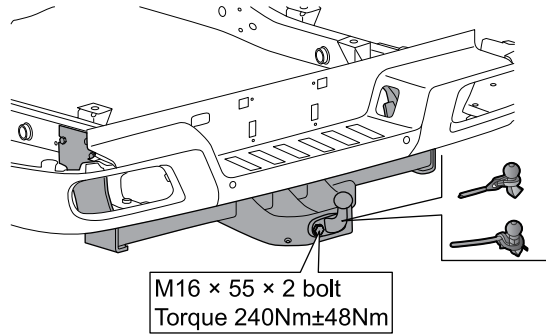

Maintenance

If the vehicle is often used to tow a trailer, additional maintenance shall be made in the maintenance intervals to ensure continuous satisfaction for the vehicle.

Type 8901, class A50-X series trailer device is approved for installation.

Approval number : E49*55R02/01*0005*01

Emergency Troubleshooting

126 Hazard warning light

126 Warning triangle

127 Self tire repair

134 Towing a vehicle

135 Jump start

137 Fuse replacement

145 Bulb replacement

Emergency Troubleshooting

Hazard warning light

When you encounter a problem during driving and have to stop the vehicle or slow down, you shall press the hazard warning light switch  in the dashboard, the "direction indicators (green)" on the instrument cluster will illuminate and flash, meanwhile all direction indicators flash to alert others and make the police know you are in trouble.

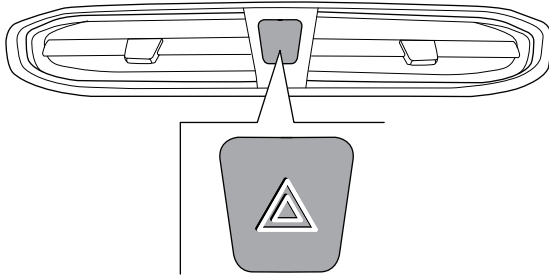

Warning triangle

Warning triangle is placed under the second-row seats.

When you encounters a problem during driving and have to pull the vehicle over, you must place a warning triangle about 100m right behind the vehicle to alert vehicles behind.

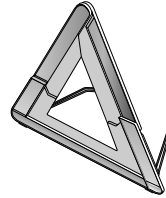

Self tire repair

Precautions



The main components of the tire cement product are natural emulsions, which are inedible, so avoid inhalation or swallowing of them. If ingested by accident, go to the hospital immediately, and do not induce vomiting.

Avoid human skin or eyes from contacting with this tire cement, otherwise skin or eyes discomfort may occur. If this tire cement contacts with skin by accident, rinse the skin thoroughly with water and soap; if this tire cement accidentally gets into the eyes, please rinse the eyes with water immediately.

Keep this product out of the reach of children.

During the use of this product, please obey the road traffic safety laws and other regulations.

- Read the Instructions carefully before using this tire cement.
- After using this product to repair a flat tire, the driving speed shall be maintained within 80 km/h.
- When using this product to repair a flat tire, due to the pressure of the flat tire, it may lead to some tire cement leakage at the connection between the glue tube and the tire, which is a normal phenomenon.
- This product adopts natural emulsion, which is same with the raw material of the tire, has no damage to tires and wheel

hubs, and can be used within the ambient temperature range of -40°C ~ 80°C.

- Please go to Our Service Dealer for inspection and repair as soon as possible after the driving is over.

Emergency Troubleshooting

Tire repair kit

Tire repair kit is placed under the second-row seats.

Tire inflator pump

Upper surface of pump body

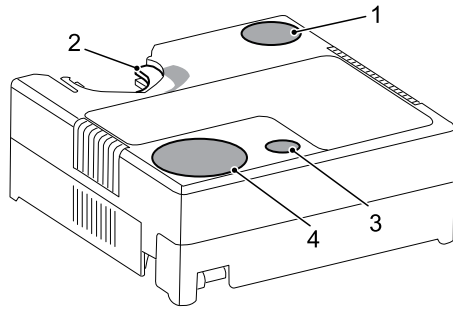

- 1 Power switch (black)
- 2 Glue pot bayonet
- 3 Relief valve switch
- 4 Air pressure gauge

Bottom surface of pump body

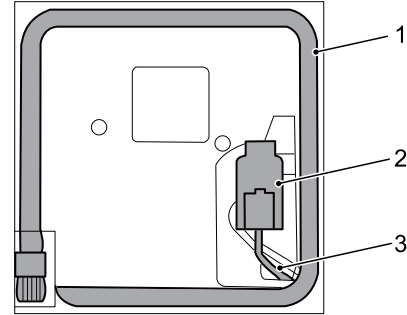

- 1 Inflation tube
- 2 Power connector
- 3 Power cord

Emergency Troubleshooting

Tire repair glue pot

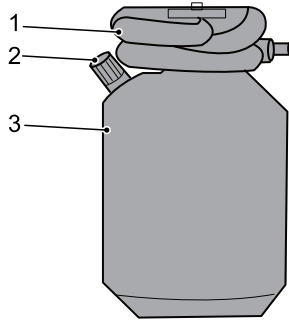

- 1 Glue tube
- 2 Inflation tube connector
- 3 Pot body

Usage

Tire repair kit has the functions of flat tire repair, tire pressure monitoring, tire inflation and deflation, etc.

Before using this product, please complete the following preparations:

- 1 Please park the vehicle in a safe place;
- 2 If a tire is flat in the course of driving, warning signs shall be set in a safe place to avoid accidents;
- 3 Identify the flat tire and determine the cause, and then complete the tire inflation or repair according to the methods for tire inflation or repair in the Instructions;
- 4 Please confirm that the tire repair glue pot and pump body are products of our company, otherwise air leakage, glue spray, adverse conditions and even dangerous consequences may occur. Please confirm that all components of product are intact before using this product;
- 5 When using this product to repair the flat tire, please check whether the glue pot is filled with glue solution.

Emergency Troubleshooting

Methods for tire repair

1 Make sure that the switch is off at this time. Loosen the glue tube on the tire repair glue pot, align and horizontally push the glue pot interface to the glue pot bayonet on the pump body, and then connect the inflation tube to the glue pot after installation is completed.

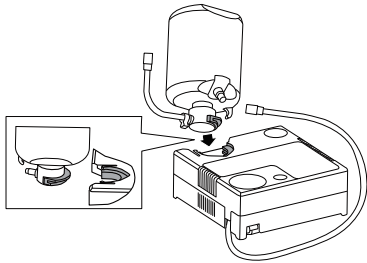

2 Connect the glue tube to the flat tire.

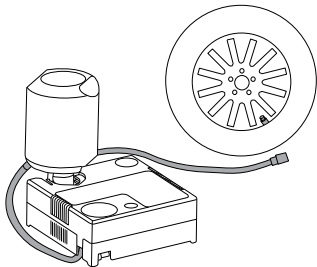

3 Insert the inflator pump power connector into the on-board power socket, and start the vehicle.

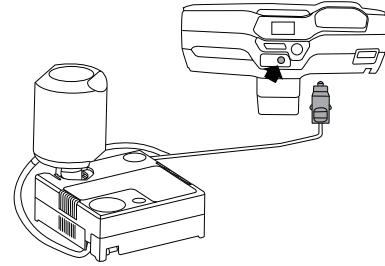

4 Turn on the power switch (black), start injecting the glue solution into the tire, at this time, the value on the pressure gauge will first rise and then slowly reduce to the flat tire pressure; turn off the power switch after the tire pressure reaches the recommended value (please see "Wheels and tires" in General Technical Parameters section), and then pull out the glue tube, inflation tube and power connector in sequence.

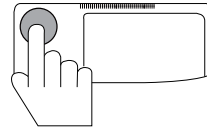

Emergency Troubleshooting

- 5 Restart the vehicle to make it drive at the speed of less than 30 km/h for 3-5 km.

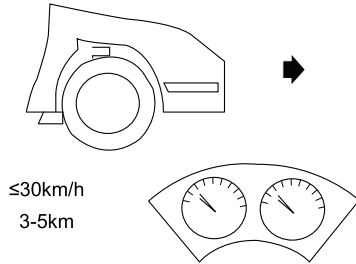

- 6 Park the vehicle in a safe place, and connect the inflation tube to the tire again.

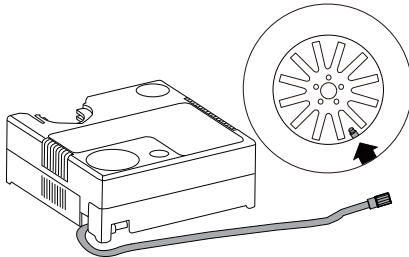

- 7 Observe the air pressure value, and perform the inflation operation if there is obvious pressure decrease. And check the tire pressure after driving for another 3-5 km (if there is still obvious pressure decrease, it indicates that the tire has been badly damaged beyond the usage range of this product, please call for rescue).

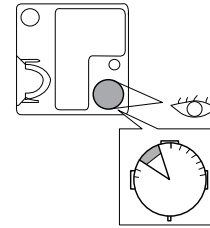

- 8 Remove the sticker with "80" character attached to the glue pot, and paste it onto the steering wheel, to remind the driver that the driving speed shall be maintained within 80 km/h after using this product.

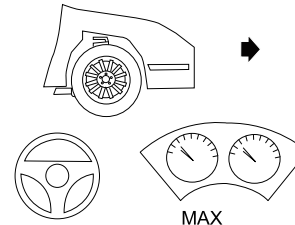

Emergency Troubleshooting

Methods for tire pressure monitoring

1 Remove the inflation tube and connect it to the tire.

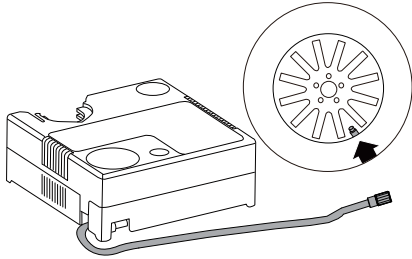

2 Insert the inflator pump power connector into the on-board power socket, and start the vehicle.

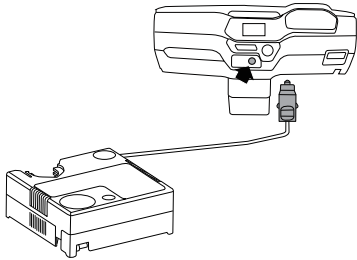

3 Turn on the power switch (black), pump up the tire, and observe the air pressure gauge; turn off the power switch after the tire pressure reaches the recommended value (please see "Wheels and tires" in General Technical Parameters section), and then pull out the inflation tube and power connector.

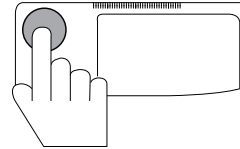

Methods for tire pressure relief

1 Remove the inflation tube and connect it to the tire.

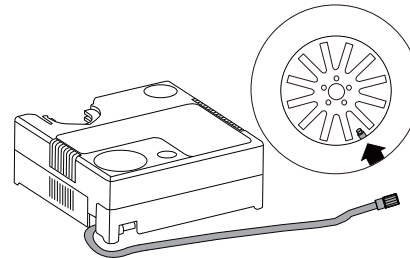

Emergency Troubleshooting

- 2 Press the relief valve switch, and observe the air pressure gauge until the tire pressure reduces to the desired value.

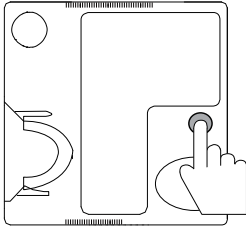

Note: After tire repair with this product, go to Our Service Dealer for tire repair as soon as possible; when professional tire repair is performed, due to residual glue solution in the tire, it is recommended to place the tire horizontally on the level ground to discharge the liquid, and it's better to put a small rag at the tire valve core, to prevent a small amount of glue from splashing out. If the tire cement accidentally drops on the floor or other objects, just wipe it off with a rag, and rinse with water. This tire cement is natural emulsion, which will cause no corrosion or other adverse effects wheel hubs and tires.

Caution

- To repair one tire, it is required to use one bottle of this tire cement product.
- To guarantee the effects in use of this product, it is better not to remove the thorn on the tire; if it is removed, the effects in use will not be influenced.
- Please do not pull out the glue tube directly from the tire during the use of this product; first turn off this product switch after the tire repair is completed, and remove the glue tube from the tire.
- When providing power for this product by starting the vehicle, apply the parking brake in advance, to avoid personal and property damages caused by vehicle movement.
- Store this product in a cool and dry place, keep it away from the fire, and try to place it in the vehicle, to better guarantee the quality of the tire cement.
- There is no side effect on the tire after using this product.
- During the use of this product, due to the compressed air, the inflation tube may become hot, which is a normal phenomenon.

Emergency Troubleshooting

Towing a vehicle

While being towed, relative national regulations about vehicle towing shall be abided by.

! Informing the rescue personnel that the vehicle being towed is a pure electric vehicle before towing. Turn off the ignition switch before towing and disconnect the manual service disconnect on the high-voltage battery pack throughout the towing.

Towing hitch

Front towing hitch

The front towing hitch is located at the lower right side of front bumper.

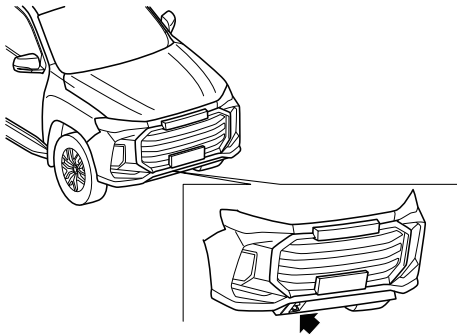

Note: For vehicles configured with front towing hitch cover, when towing the vehicle, it is required to remove the towing hitch cover. First press the upper end of the cover inward, and rotate it to pull out the towing hitch cover. After removal, please note that the towing hitch cover shall be placed in the vehicle in case of loss, and reinstall the towing hitch cover after vehicle towing is completed.

Caution

The mass that the front towing eye can bear is 1/2GVW (total mass). Do not tow the vehicle with a mass more than this value.

The application range of towing rope is as shown below:

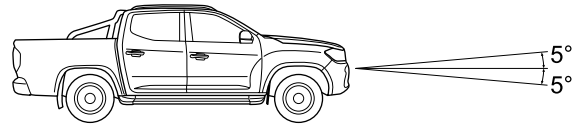

Emergency Troubleshooting

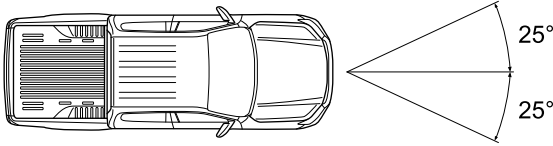

Caution

- It is forbidden to tow with the rear wheels on the ground, or use a scooter for direct consignment.
- When the vehicle is loaded and unloaded from the tractor, the speed shall not be higher than 5km / h when the rear wheels touch the ground.
- When the rear wheel is pulled off the ground, the traction speed shall not be higher than 30km / h and the traction distance shall not be greater than 50km.
- Do not use this vehicle to tow other vehicles.
- Reverse traction is prohibited, otherwise the internal gear mechanism of the electric drive system will be damaged.

Jump start

Battery disconnection

! Always wear protective gloves and eye protecting glasses when working on a battery. Do not use naked light, cause sparks or smoke in the area of the battery. You can be seriously injured and the vehicle damaged.

To disconnect battery, disconnect negative (-) earth terminal first and then positive (+). To connect battery, install and secure positive cable (+) first and then negative (-) cable. Smear the terminals with petroleum jelly.

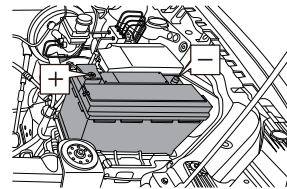

Caution

Before disconnecting the battery, always switch off the motor and all electrical devices for more than 2 minutes. While disconnecting, never allow the terminal to contact with the metal parts of vehicle body. Otherwise short circuit may cause electric spark. Electrical system may be damaged if connecting positive and negative cables reversely.

Emergency Troubleshooting

Jump start



Never pull or tow the vehicle to start.

Ensure the rated voltage of two batteries is the same (12 V) and the jumper cable is acknowledged as the cable used for 12V vehicle battery.

Jumper

- 1 Pull two vehicles together as possible.
- 2 Switch off all electrical devices.
- 3 Connect the positive terminals (+) of two batteries with red jumper cable.
- 4 Connect black jumper cable from power supplying battery negative terminal (-) to earth point (not negative terminal) of battery that needs to be powered.
- 5 Ensure all connection mechanisms are well connected.
- 6 Check that the jumper cable clear of any moving parts when the motor starting.
- 7 Check whether the parking brakes of the two vehicles are applied and the shift lever is in N position.

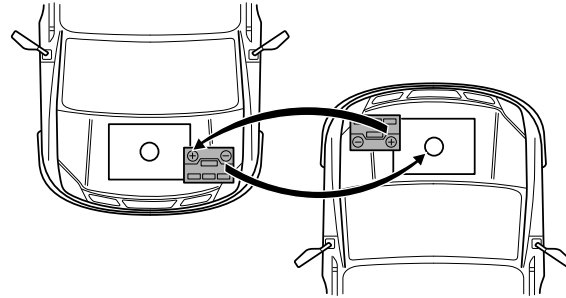

Starting

Start the vehicle whose battery supplies power and allow it to idle for several minutes.

- 1 Start the vehicle whose battery needs to be powered.
- 2 After starting the vehicle, allow it to run for two minutes above.

Note: If it fails to start after several attempts, the vehicle may need maintenance.

Disconnecting

- 1 Switch off the engine or drive motor of the vehicle that supplies power.
- 2 Ensure the cable terminals shall not contact with each other.
- 3 Remove the jumper cable. Removal is the reverse of connection.

Emergency Troubleshooting

Fuse replacement

Fuses of this vehicle are located in three boxes.

Caution

Spillage of liquid to any electric components in the vehicle may damage the components, so it is required to cover any electric components. The content of the fuse specification list will be constantly updated according to the vehicle configuration and technical status, please refer to actual state of your vehicle.

Driver compartment fuse box

Driver compartment fuse box is located behind the lower storage box at driver side.

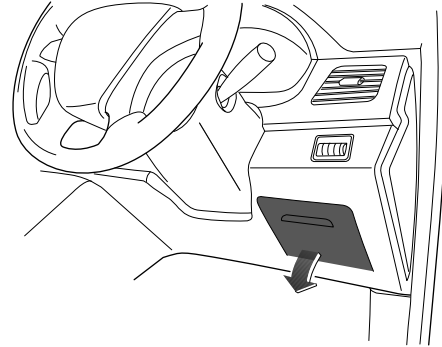

Emergency Troubleshooting

Fuses in the driver compartment fuse box can be identified by the label on the back of lower storage box cover at driver side.

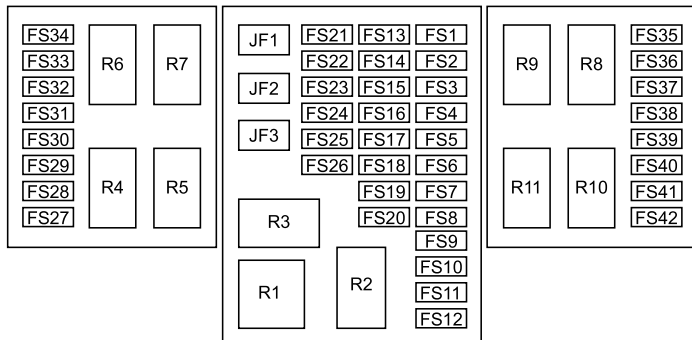

Specifications

Code	Specification	Function
FS1	10A	Low speed alarm/three in one controller/BMS/VMS
FS2	10A	Instrument/BCM/PEPS/BSD
FS3	10A	Airbag control module
FS4	7.5A	ABS/ESC
FS5	10A	Tire pressure monitoring/automatic anti-glare rearview mirror/gateway/LDW
FS6	10A	EPS/front air conditioning panel
FS7	7.5A	BCM_Rearview mirror fold

Code	Specification	Function
FS8	25A	BCM_Central lock
FS9	7.5A	BCM_Interior lamp
FS10	10A	BCM_Charging port panel actuator
FS11	10A	BCM_Windshield washer
FS12	25A	BCM_Exterior lamp
FS13	10A	Entertainment system screen
FS14	25A	Inverter
FS15	10A	Driver seat heater
FS16	10A	Front passenger seat heater
FS17	15A	12V socket/blower relay coil
FS18	10A	PEPS/inverter/rearview mirror adjustment/trailer/power window
FS19	20A	Cigar lighter
FS20	10A	Gateway/radio
FS21	10A	OBD/rear camera/TPMS(tire pressure monitoring)/RF receiver
FS22	10A	Shift control unit
FS23	25A	Entertainment system
FS24	10A	Instrument/IMMO base station
FS25	20A	Horn
FS26	10A	A/C front panel/LDW/rain solar sensor

Emergency Troubleshooting

Code	Specification	Function
FS27	10A	Air conditioning heating/shift control unit/motor control unit kl15 power supply
FS28	10A	Front blower feedback signal
FS29	25A	Driver window regulator motor
FS30	25A	Front passenger window regulator motor
FS31	25A	Rear left window regulator motor
FS32	25A	Rear right window regulator motor
FS33	15A	Gateway
FS34	7.5A	Rearview mirror heater
FS35	/	Reserved
FS36	/	Reserved
FS37	25A	Towing power supply 1
FS38	25A	Towing power supply 2
FS39	/	Reserved
FS40	/	Reserved
FS41	/	Reserved
FS42	/	Reserved
JF1	/	Reserved
JF2	25A	Driver seat adjustment
JF3	25A	Front passenger seat adjustment

Code	Specification	Function
R1	40A	Front blower relay
R2	30A	ACC relay
R3	30A	IG relay
R4	/	Reserved
R5	30A	Horn relay
R6	30A	Left power window relay
R7	30A	Right power window relay
R8	30A	Driver seat adjustment relay
R9	30A	Front passenger seat adjustment relay
R10	30A	Rear window/mirror heating relay
R11	/	Reserved

Emergency Troubleshooting

Front compartment fuse box

Front compartment fuse box is located at the right of compartment wall at the front hood bottom (viewed from the front of vehicle).

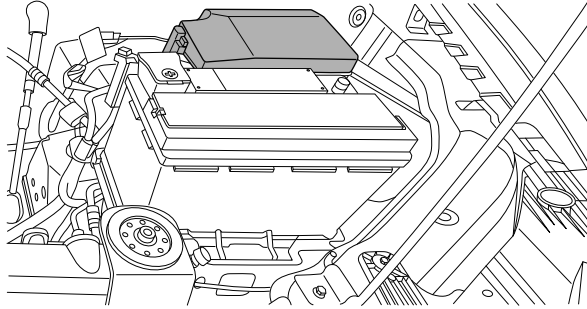

Caution

Before opening the fuse box cover, make sure its surroundings are dry and no fluid flows from any direction into the opened fuse box, otherwise the fuse box will be damaged, leading to serious consequences.

Fuse can be accessed by just removing the cover of front compartment fuse box. Fuses in the front compartment fuse box can be identified by the label printed at the back of the fuse box cover.

Emergency Troubleshooting

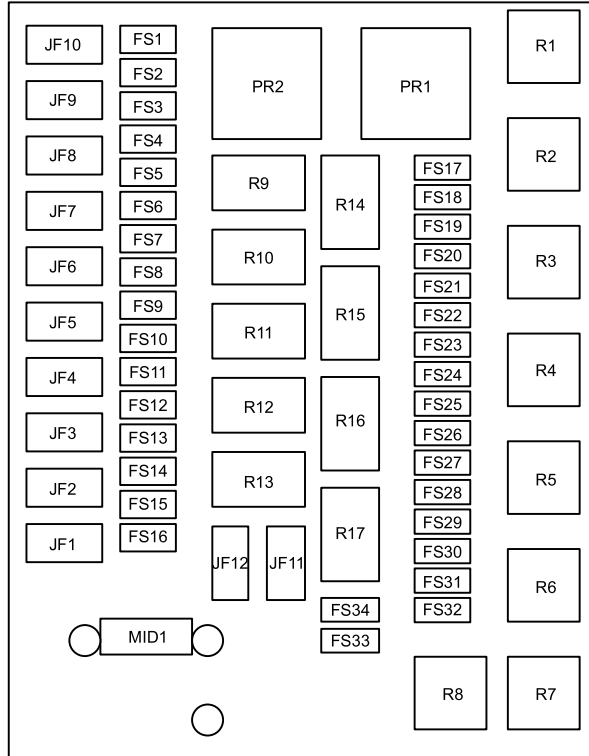

Specifications

Code	Specification	Function
FS1	15A	Motor controller
FS2	25A	Rear window/mirror defrost
FS3	30A	IEC (driver compartment fuse box) power 6 (instrument/anti-theft base station/Horn/front air conditioning control panel/LDW/rain and sunshine sensor)
FS4	/	Reserved
FS5	25A	ABS valve
FS6	30A	Trailer power
FS7	25A	Front wiper motor
FS8	15A/10A	Ignition switch (PEPS/Electronic steering column lock)
FS9	15A	A/C Compressor
FS10	30A	IEC (driver compartment fuse box) power 7 (BCM_Folding, door lock and interior lamp power supply)
FS11	/	Reserved
FS12	30A	IEC (driver compartment fuse box) power 5 (OBD/reversing camera/RF receiver/tire pressure monitoring/shift control/entertainment host)
FS13	25A	Low beam/headlamp regulating motor/dimmer switch

Emergency Troubleshooting

Code	Specification	Function
FS14	20A	High beam
FS15	10A	Daytime running lamp/position lamp/rear fog lamp
FS16	20A	IEC (driver compartment fuse box) power 8(BCM_Charging port panel/front washing motor power input)
FS17	20A	Main relay power supply of VMS
FS18	20A	Water pump power supply
FS19	15A	Coil end of electronic water pump relay(VCU control)
FS20	10A	VMS_KI30 power supply
FS21	/	Reserved
FS22	/	Reserved
FS23	10A	BMS_KI30 power supply
FS24	/	Reserved
FS25	/	Reserved
FS26	10A	Charging and distribution unit_KL30
FS27	/	Reserved
FS28	15A	Left high beam
FS29	15A	Right high beam
FS30	15A	Left low beam
FS31	15A	Right low beam

Code	Specification	Function
FS32	10A	Adjust headlamp leveling motor
FS33	/	Reserved
FS34	/	Reserved
JF1	30A	Main relay
JF2	40A	VMS/high-voltage battery/Charging and distribution unit
JF3	30A	Electronic vacuum pump
JF4	30A	IEC (driver compartment fuse box) power 1(IG relay/inverter)
JF5	30A	IEC (driver compartment fuse box) power 2(ACC relay/left and right power window control terminals)
JF6	30A	IEC (driver compartment fuse box) power 3(Driver's seat adjustment motor/display)
JF7	30A	IEC (driver compartment fuse box) power 4(Passenger seat adjustment/heating of driver's seat and passenger's seat)
JF8	40A	ABS pump
JF9	40A	Front blower
JF10	/	Reserved
JF11	60A	Power window

Emergency Troubleshooting

Code	Specification	Function
JF12	30A	IEC (driver compartment fuse box) power 9(BCM_Exterior lamp power supply/gateway)
MID1	80A	Cooling fan 600W
PR1	/	Reserved
PR2	/	Reserved
R1	/	Reserved
R2	40A	Electronic vacuum pump relay
R3	/	Reserved
R4	/	Reserved
R5	/	Reserved
R6	40A	Wiper power supply relay
R7	40A	Wiper speed adjustment relay
R8	40A	Main relay
R9	/	Reserved
R10	30A	Rear fog lamp relay
R11	30A	Position lamp relay
R12	/	Reserved
R13	/	Reserved
R14	30A	Low beam relay
R15	30A	High beam relay

Code	Specification	Function
R16	30A	Left daytime running lamp relay
R17	30A	Right daytime running lamp relay

Emergency Troubleshooting

Battery fuse box

The battery fuse box is located on the battery positive terminal.

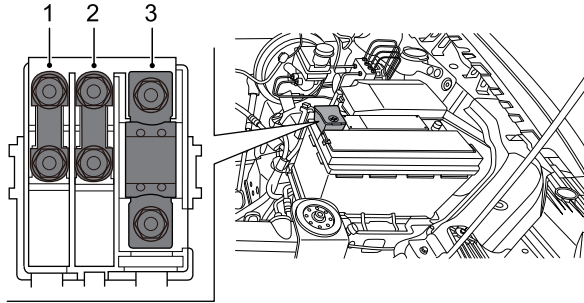

Fuse	Specification	Function
1	175A	UEC (front compartment fuse box)
2	70A	EPS (electric power steering unit)
3	250A	CDU (charging and distribution unit)

Fuse replacement

! Only replace with fuses of the same specifications/rated current. Installing nonspecific fuse will damage electrical system and even cause fire.

Before attempting to replace the fuse, ignition switch and all electrical devices shall be turned off. Any unauthorized change to vehicle electrical system will cause serious adverse effect and fire on the electronic management system.

Pull the fuse outward with puller provided in fuse box to remove the fuse.

Internal wiring of the fuse can be used to identify blown fuse (arrowed).

Note: Repeated failure with the same fuse is the indication of circuit failure. Please contact Our Service Dealer as soon as possible.

Emergency Troubleshooting

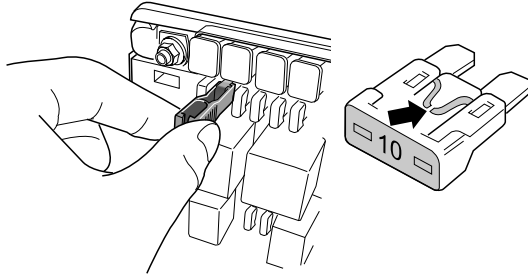

Caution

Unauthorized change to electrical system of the vehicle will invalidate the warranty.

Bulb replacement

Before replacing any bulb, turn off the ignition switch and the lamp switch, to avoid any possible short circuit.

When removing or installing the bulb, do not touch the bulb with hands. If touched, wipe away the hand print with a piece of cloth or alcohol.

Caution

The type and specification of replaced bulb must be the same as that of the original bulb. For the lamp with the bulb of LED type, its bulb cannot be removed or replaced separately.

3

Emergency Troubleshooting

Bulb specification

Lamp	Specification
Low beam (Type 1)	H7
High beam (Type 1)	H7
Front turning signal lamp (Type 1)	LED
Front position lamp (Type 1)	LED
Low beam (Type 2)	LED
High beam (Type 2)	LED
Front turning signal lamp (Type 2)	LED
Front position lamp (Type 2)	LED
Rear turning signal lamp	PY21W
Brake lamp/rear position lamp (Type 1)	P21/5W
Brake lamp/rear position lamp (Type 2)	LED
Reverse lamp	W16W
Rear fog lamp (Type 1)	P21W
Rear fog lamp (Type 2)	LED
License plate lamp	W5W
Front ceiling reading lamp	W5W
Rear ceiling reading lamp	C5W

Bulb replacement

The followings are the methods for removing the bulb; for other unlisted bulbs that need to be replaced, please contact Our Service Dealer for repair. The bulb installation is the reverse of removal, which will not be described below.

Front combination lamp (Type 1)

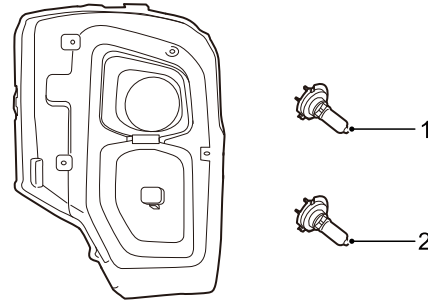

1 Low beam

Open the bonnet, and perform the following operations at the rear of front combination lamp:

- Turn the bulb cover counterclockwise, to remove it.
- Remove the bulb.

Emergency Troubleshooting

2 High beam

Open the bonnet, and perform the following operations at the rear of front combination lamp:

- Turn the bulb cover counterclockwise, to remove it.
- Remove the bulb.

Rear combination lamp (Type 1)

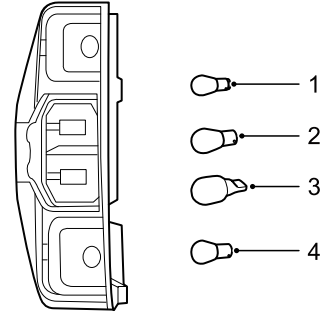

1 Brake lamp/rear position lamp

Open the tailgate, and perform the following operations to remove the rear combination lamp:

- Turn the bulb cover counterclockwise, to remove it.
- Remove the bulb.

2 Rear turning signal lamp

Open the tailgate, and perform the following operations to remove the rear combination lamp:

- Turn the bulb cover counterclockwise, to remove it.
- Remove the bulb.

Emergency Troubleshooting

3 Reverse lamp

Open the tailgate, and perform the following operations to remove the rear combination lamp:

- Turn the bulb cover counterclockwise, to remove it.
- Remove the bulb.

4 Rear fog lamp

Open the tailgate, and perform the following operations to remove the rear combination lamp:

- Turn the bulb cover counterclockwise, to remove it.
- Remove the bulb.

Rear roof vanity light

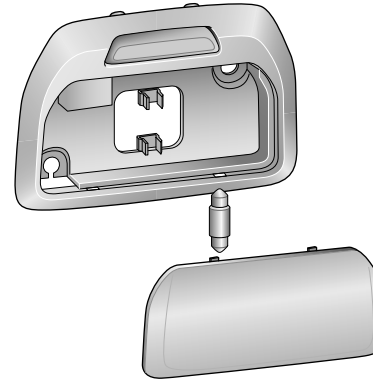

Carefully pry up the lamp shade with a screwdriver or equivalent.
Remove the bulb of rear roof vanity light.

Maintenance and Service

- 150 Regular maintenance
 - 150 Owner's check
 - 151 Front compartment
 - 152 Front compartment hood
 - 153 Coolant
 - 154 Brake fluid
 - 155 Washer fluid
 - 156 Washer nozzle
 - 156 Wiper blades
 - 158 Seat belts
 - 159 Battery
 - 164 High-voltage battery pack
 - 166 Tires
 - 168 Other maintenance
-

Maintenance and Service

Regular maintenance

Regular maintenance is the key to economy, safety and reliability for your vehicle and it must be remembered that the responsibility for maintaining your vehicle in a safe, roadworthy condition rests ultimately on you, the owner/operator.

Necessary maintenance and the intervals have been specified to maintain your vehicle properly. Regular vehicle maintenance shall be done by Our Service Dealer in accordance with Warranty & Service Handbook.

It is in your best interest to have your vehicle regularly maintained in accordance with regulations.

Our Service Dealers are recommended as they have qualified personnel, required facilities and can offer the unique pre-planned service which will give maximum vehicle reliability.

Owner's check

The following are a few simple but important checks which you should make at regular intervals before driving to ensure reliable, economic operation:

Daily checks

- The lighting (make sure all lens are clean), horn, instrument cluster, warning lights and indicators, wipers and washers are functioning.
- The seat belts are intact.
- The brakes operates normally.
- Visually check for signs of water, fluid, exhaust and other leaks under the vehicle.

Maintenance and Service

Weekly checks or check before a long journey

- Check fluid level/refill.
 - Coolant
 - Brake fluid
 - Windshield washer fluid
- Check for condition and pressure of all tires.
- Check and operate AC system.

Harsh conditions

For vehicles often used in harsh conditions, it is recommended to shorten the maintenance interval.

Regular vehicle maintenance shall be done by Our Service Dealer in accordance with Warranty & Service Handbook.

Front compartment

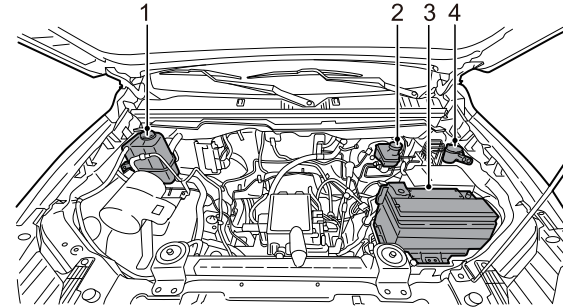

- 1 Coolant reservoir
- 2 Brake fluid reservoir
- 3 Battery
- 4 Washer fluid reservoir

Maintenance and Service

Front compartment hood

Open front compartment hood

- 1 Pull the front compartment hood release switch below the driver side lower guard to release the front compartment hood.

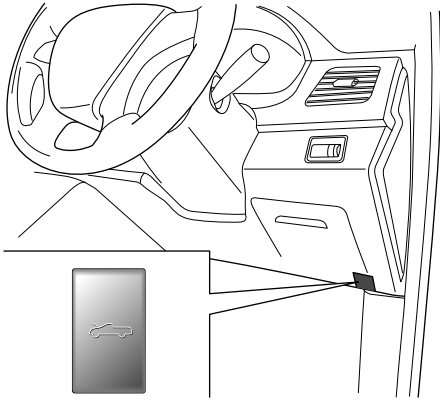

- 2 Slightly raise the front part of front compartment hood, push the lever to right and lift the front compartment hood.

Close front compartment hood

Press the front part of the front compartment hood down until the lock catch is heard to engage. Attempt to pull the front compartment hood upwards to check whether the lock mechanism is properly snapped.

Caution

Before closing, check that there is no tools, rags, equipment, etc. left in the area under the front compartment hood.

Coolant

 **Coolant is harmful if swallowed. Do not allow coolant to contact the eyes or skin. If it does, rinse immediately with plenty of water.**

Please add coolant with correct specification. Never driving the vehicle if coolant of correct specification is not filled. For coolant specifications, see "Recommended fluids" in General Technical Parameters section.

At specified intervals the cooling system should be drained, flushed and refilled with the correct amount of coolant.

Caution

When refilling or replacing coolant, only the specified coolant can be used. The use of non-recommended coolant could cause damage to the cooling system and may invalidate the warranty.

Check and refill

 **Do not remove the expansion tank cap while the cooling system is hot, for overflowed water vapor or hot coolant may cause personal injury. If coolant has to be refilled when the cooling system is hot, please wait for 10 minutes, place a thick cloth over the coolant reservoir cap and turn the cap counterclockwise slowly to release the pressure inside the reservoir, and then remove the cap.**

Always check the coolant level with the vehicle on level ground and the cooling system stationary (cold state).

The fluid level is visible on the coolant expansion tank, and the normal level should be between the "MAX" (the maximum amount) and "MIN" (the minimum amount) marks.

If the level drops to the "MIN" mark, clean the area around the coolant reservoir cap and rotate the cap counterclockwise to remove it. Top up with the specified coolant between "MAX" and "MIN" marks. Install the reservoir cap.

Note: The coolant may expand when it becomes hot, so the liquid level may be higher than the level mark.

Caution

If the level has fallen appreciably, or topping-up is required frequently, suspect leakage or overheating and contact Our Service Dealer for service as soon as possible.

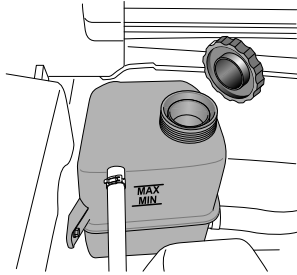

Precautions for cold weather

In order to reduce possible problems which may occur in cold weather, please consider the following suggestions:

- Since the standard freezing point of the coolant used in the vehicle is -35°C (with the mixture ratio of coolant stock solution and water of 1:1), it is necessary to park the vehicle in areas where the coolant temperature can be maintained above -35°C .
- If you are using your vehicle in extremely cold areas where the ambient temperature is below -35°C , please use the coolant of appropriate proportion based on the local temperature. (Refractometer T10007 can be used to detect the freezing point of the coolant)

Brake fluid

! If there is a significant drop in the level of the brake fluid, contact Our Service Dealer for service as soon as possible.

Use only new brake fluid of the specified type. Use of brake fluid which is old or not the specified type can cause loss of braking performance.

Brake fluid cleanliness is essential. Any dirt entering the system can cause loss of braking performance.

Do not allow brake fluid to contact your skin or eyes; If it does, rinse immediately with plenty of water. Keep brake fluid out of the reach of children.

Note: Fluid used in the hydraulic clutch also comes from the brake fluid reservoir.

Caution

- Only refill the brake master cylinder with brake fluid complying with specification DOT4. Do not use brake fluid of any other type.
- Brake fluid will damage the paintwork when coming in contact with it. Wipe it clean immediately and rinse with water.

Check and refill

Be sure to check the brake fluid level after the vehicle is parked on a flat ground and the brake system is in cold state. Brake fluid level is visible on the reservoir and the normal level shall be between "MAX" and "MIN" marks. If the level drops to "MIN" mark, clean the area around the filler cap and then turn the reservoir cap counterclockwise to remove it. Refill with specified new brake fluid to the level between "MAX" and "MIN" marks and close the reservoir cap.

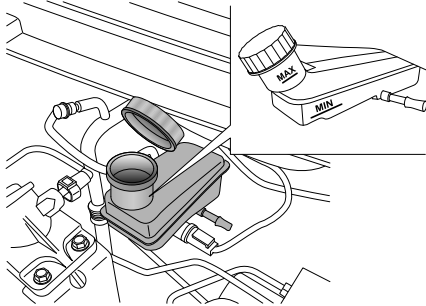

If the level is lower than the "MIN" mark, "Brake System Warning Lamp (red)" on the message center display will illuminate. This indicates a fault in the braking system, the cause must be identified immediately. If driving, IMMEDIATELY bring the vehicle carefully to a halt. Contact Our Service Dealer for service as soon as possible. Do NOT continue driving.



Never discard used brake fluid casually to avoid the environment pollution.

Washer fluid

Check and refill

⚠ Driving with a non-operational washer system can be dangerous; always check it before driving.

The windshield washer fluid reservoir is located in the front compartment. To refill, lift the front of the filler cap to refill washer fluid and then replace it. For washer fluid specifications, see "Recommended fluids" in General Technical Parameters section.

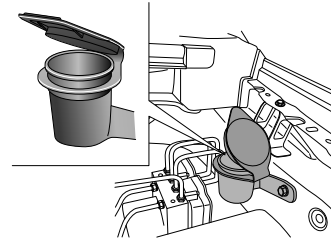

Caution

Do not use washer fluid that does not comply with requirements. Do not use tap water as mineral substance in tap water can easily block the windshield washer fluid pipeline or nozzle, and tap water will freeze below 0°C, and it will easily burn the washing motor in use after freezing.

Washer nozzle

Adjustment and cleaning

Front washer nozzle

Prior to carrying out jet adjustment or cleaning, ensure that the washer reservoir is topped-up. Clean the nozzle with a thin thread or needle carefully if the nozzle is clogged.

The direction of washer jet has been set in manufacturing works and normally no adjustment is required. If any adjustment is required, carefully insert a fine needle into the jet hole to re-position the jet to direct the spray direction towards the middle of the windshield.

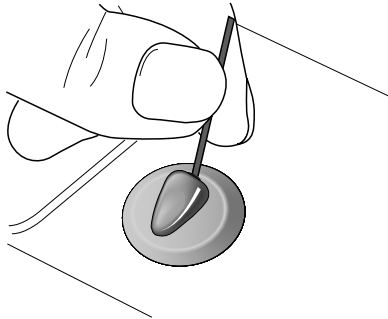

Wiper blades

Check

Examine the edge of the blade for roughness or damage, and check that the blade rubber is secure throughout its length.

Note: *Traces of grease and other impurities on the rubber can prevent the wipers from working correctly, and can also damage the windshield.*

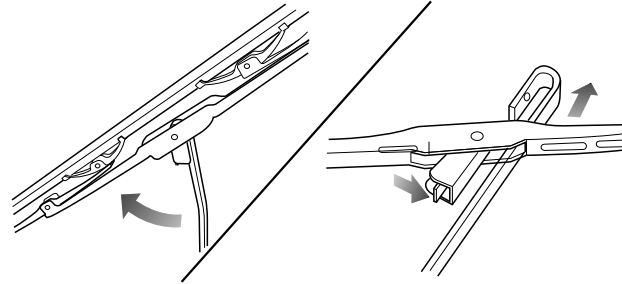

Maintenance and Service

Replacement

Removal

- Lift the wiper arm from the windshield, then make the blade and arm maintain at a right angle.
- Push down the retaining clip (arrow direction), then slide the blade bracket to the lower side of the arm so that the pivot on the bracket can be separated from the hook on the arm.

Note: Remember the relative location of hook and bracket because the replacement blade is required to be fitted later in the same way.

Installation

- Install the blade bracket on the hook.
- Snap the pivot into the hook and push it in place, until hearing an audible sound of snapping into place.

Maintenance and service

Wash with high-quality cleaner or neutral detergent and wipe it clean with a dry, soft cloth that is free of lint.

Maintenance and Service

Seat belts

Inspection



The belts also have a sensitive retractor which is designed to lock only during heavy acceleration, deceleration or sharp turns.

Do NOT attempt to test the locking device by intentionally 'launching' your upper torso in a forward direction.

Check ALL seat belts as follows:

- Inspect all belt anchorage points for safety.
- Insert the locking tab into the buckle and check for a clear locking action. Push the red button and check if the locking tab pops neatly.
- With the belt half unreeled, hold the locking tab and give it a sharp pull. Check if the safety mechanism can be locked automatically and prevent further looseness.

Maintenance and service



Do not attempt to repair the retractor or buckle mechanisms, or to modify the seat belts in any way. Seat belts subjected to strain as a result of an accident shall be replaced and the anchorage points checked by Our Service Dealer.

Regularly inspect the belt webbing for signs of abrasion or wear, paying particular attention to the anchorage points and adjusters.

Clean the seat belt with a sponge dipped with warm water and mild soap; it can be naturally dried, and should not be dried by direct heating or exposure under sunlight. Do not allow water to penetrate into the retractor. Never bleach or dye a seat belt as its strength may be reduced.

Battery

Warnings and instructions for battery:

Wear goggles!

The battery acid is strongly corrosive. Ensure to wear protective gloves and goggles!

Open fires, electric sparks, strong lights and smoking are strictly prohibited!

Explosive gas mixture may be generated during battery recharging!

Ensure to keep any child away from the acid and the battery!

 **There may be risks of injury, corrosion, accident and fire during operations on the battery and any electric apparatus in the vehicle! Ensure to wear goggles. Do not let any acid or leaded grains into your eyes or onto your skin or clothes.**

The acid liquor in battery is strongly corrosive. Ensure to wear protective gloves and goggles. Do not turn over the battery, or acid liquor may be discharged from the exhaust vent.



If any acid liquor touched your eyes, immediately flush with clean water for several minutes before seeing the doctor. If any acid liquor spills onto your skin or clothes, immediately neutralize it with thick liquid soap, and then flush with plenty of water. If any acid liquor is swallowed accidentally, see the doctor immediately.

The acid liquor in battery is strongly corrosive. Ensure to wear protective gloves and goggles. Do not turn over the battery, or acid liquor may be discharged from the exhaust vent. If any acid liquor touched your eyes, immediately flush with clean water for several minutes before seeing the doctor. If any acid liquor spills onto your skin or clothes, immediately neutralize it with thick liquid soap, and then flush with plenty of water. If any acid liquor is swallowed accidentally, see the doctor immediately.

Any open fire, spark, hard light and smoking is strictly forbidden. During working on cables and electric devices and removing electrostatic loads, avoid generating any spark. The electrodes of battery can NEVER be short-circuited, or may cause injury due to large energy spark.

Explosive gas mixture may be generated during battery recharging. The gas vent of battery should be kept unblocked to discharge the gas correctly.

Maintenance and Service



During recharging, the battery should be located in a space with good ventilation.

Ensure to keep any child away from the acid liquor and the battery.

Before working on any electrical equipment, please turn off the power switch and all of the electrical equipment. Remove the negative cable of battery. When replacing bulbs, only the lights are required to be shut down.

Pay attention to the polarities of power supply. Before powering on, the matches of polarities must be checked.

The duration of each powering on should not be less than 5 seconds. Try to avoid powering on and off too frequently.

When removing the battery, please remove the negative cable before positive cable.

Before powering on the battery again, all of the electrical equipment should be shut down. Connect the positive cable before negative cable. Never connect the cables incorrectly - risk of fire!

Unauthorized removing and installing of battery is strictly forbidden. In some cases, such operations may cause severe damage to the battery and fuse box. Please contact our Service Dealer.

Duration of storing the vehicle

If the vehicle is parked for an extended period of time, the static current electrical appliance (like clock, security devices) will drain the battery, and the battery has to be recharged. To avoid such cases, charge the battery or disconnect the negative battery cable during the vehicle parking.

Note: Please pay attention to the warnings & instructions for battery before working on it.

Caution
Ensure to turn off the ignition switch during parking, otherwise the parking duration will be reduced significantly.

Operating in winter

There are particularly strict requirements on the vehicle battery operation in winter. In addition, the starting power provided by the battery at low temperature is only a part of that at normal temperature. Therefore, we recommend to have the vehicle battery checked by Our Service Dealer before the cold season begins, and recharge it if necessary.

If the vehicle is not used for weeks in cold season, please remove the vehicle battery and store in an ice-free room, to prevent it from freezing and damage.

Charging the battery with ground equipment



Do not charge any frozen battery, there is a risk of explosion! Even if the battery has been unfrozen, there may be battery acid spilling out and cause corrosion. Any frozen battery must be replaced.

Turn off the ignition switch and all electrical appliances before charging.

If the vehicle has been parked for a long period and cannot be started due to lack of power (general terminal voltage $\leq 12V$), the battery must be removed from the vehicle and charged with a ground equipment (follow the instructions provided by the manufacturer of the charging equipment).

During charging with small current (e.g., a small charging equipment), it is unnecessary to remove the connecting cables of battery. However, please ensure to read the instructions from the manufacturer of the charging equipment.

Before fast charging (i.e., large current charging), both of the connecting cables must be removed.

Note: Please pay attention to the warnings & instructions for battery before working on it. During the charging, the charging equipment can only be powered on after the electrode clamps of charging equipment is connected to the electrodes of battery as required. After the charging is finished, turn off the charging equipment first, remove

Maintenance and Service

the power cable, and then remove the electrode clamps of charging equipment from the battery.

Caution

- Keep any child away from the battery, battery acid and charging equipment.
- The battery can only be charged in a space with good ventilation. Smoking is prohibited, and keep away from open fires and electric sparks, as explosive gas mixture may be generated when the battery is charged.
- Protect your eyes and face, never be too close to the battery.
- If acid splashes onto your eyes or skin, immediately rinse with clean water for several minutes before seeing the doctor.
- The fast charging of the battery is dangerous, which should be done by Our Service Dealer, because it requires professional charging equipment and knowledge.
- Any frozen or unfrozen battery must be replaced. Because cracks may be found on the frozen battery housing. It may cause leak of battery acid and damage to the vehicle.

Removing the battery

Turn off the ignition switch and all electrical appliances before the battery removal. To remove the battery, firstly remove the negative cable and then the positive cable. And then remove the bolt on the mounting bracket of battery to remove the battery.

Replacing the battery

The battery installed on your vehicle is designed for the corresponding mounting location. To replace the battery, please ensure to use one with the same voltage (12V), structure and safety label. The current strength and capacity should be same with the original battery. Our Service Dealer can offer you with original batteries. When installing the battery, please ensure that the ignition switch is turned off and all electric appliances are turned off.



Concerning the disposal of used battery, it is suggested to have the battery replaced by Our Service Dealer. Additionally, the battery can never be treated as household garbage because it contains sulfuric acid and lead.

Installing the battery

Before installing the battery, please turn off the ignition switch and all electrical appliances. Put the battery in the installation position prepared for it, and fix it with the battery bracket. When connecting the battery, please fix the positive cable before the negative cable.

Caution

To prevent the battery from discharging, please turn off the ignition switch when you leave the vehicle.

High-voltage battery pack

Instructions and restricted conditions

 **According to the characteristics of the lithium battery, the vehicle must be charged and discharged every 30 days in storage period, a long time parking easily results in damage of battery, thereby affects the running of whole vehicle. Failure to do so may result in loss or damage of the power battery, which may affect your enjoyment of the free warranty!**

Pure electric vehicle is different from the conventional vehicle, therefore it has particularity on aspects of operation, storage and maintenance, and now some cautions are informed to you.

1 The vehicle cannot be parked for over eight hours in a place where temperature is over 60°C. Vehicle cannot be parked for over 20 hours in a place where temperature is lower than -30°C. Vehicle shall not be parked for more than 15 days in a place where temperature is above 45°C. If it exceeds maximum limit of the storage environment of vehicle, it will directly affect performance of vehicle and lifetime of high voltage battery pack.

Vehicle cannot be parked in high-temperature places.

2 To better extend the service life of high-voltage battery pack, it is recommended adopting slow charging. Fast charging is mainly used for emergency and long-distance driving.

- 3 Setting the A/C to the heating mode greatly reduces the driving range of the vehicle; setting the A/C to the cooling mode just slightly reduces the driving range of the vehicle. Deep discharge will reduce the battery life; shallow charge shallow discharge will extend the battery life. Low temperatures significantly reduce the driving range of the vehicle; high temperatures have no effect on the driving range of the vehicle. Fast charging has no effect on the driving range of the vehicle.
- 4 Vehicle will be kept dry and cannot be placed in damp environment for long time such as parking place with ponding. If the vehicle is immersed in water or waded into the water, it shall be parked in dry place.
- 5 If the vehicle will not be used for a long time (over three months), make sure the battery level of the high-voltage battery pack is around 50%. Vehicle cannot be parked for over 7 days with the battery level of the high-voltage battery pack below 20%.
- 6 Do not disassemble the high-voltage battery pack and related components for repair without approval, otherwise our Service Dealer will not fulfill the warranty terms.

Maintenance and Service

- 7 It is recommended to use the vehicle at least once a month. It is recommended to conduct a slow-charging on the vehicle for more than 10 hours every month to extend the life of high-voltage battery pack. It is recommended to get the vehicle fully charged every month or every 2000km, and the charging gun will be automatically disconnected after the vehicle is 100% charged (i.e. do not stop charging by manual operation, but wait for the charging pile to charge the vehicle high-voltage battery pack to the cut-off voltage and actively stop charging).
- 8 High voltage battery pack is easily damaged at chassis position through scraping and collision. Therefore, you shall timely contact our Service Dealer if the vehicle has driven on abnormal pavement to check whether the high voltage battery pack has deformation or not and whether enclosure has crack or not.
- 9 If the vehicle encounters collision and scraping in the utilization process, the vehicle will be timely checked by our Service Dealer to confirm whether the high-voltage battery pack has deformation or not and whether the enclosure has crack or not; if serious accident occurs, after accident has been disposed, you shall contact our Service Dealer to transfer the vehicle to our Service Dealer for check.
- 10 After a serious vehicle accident, personnel in the vehicle need leave the vehicle as soon as possible and contact our Service Dealer for disposal at once.
- 11 If the vehicle body need be repaired or painted due to damaged in an accident, you must contact our Service Dealer to avoid manual damage or fire disaster of high-voltage battery pack and relevant operation can be conducted after dismantling the high-voltage battery pack.
- 12 Please fully charge the battery when the vehicle is used for the first time.
- 13 Under a continuous climbing or high-speed driving condition at extremely high temperature in summer, in order to prevent the high-voltage battery pack from overheating, the available power of high-voltage battery pack at high temperature shall be lower than that at normal temperature, otherwise it may cause the vehicle to be unable to continuously travel at its maximum speed.

Maintenance and Service

Tires



DEFECTIVE TIRES ARE DANGEROUS! Do NOT drive your vehicle if any tire is excessively worn or damaged, or is inflated to an incorrect pressure.

Frequently inspect the tires and sidewalls for any sign of distortion (bulges), cuts or wear. Flints and other sharp objects should be removed with a suitable blunt tool. If neglected, they may work through the tire.

Tire pressure



Driving with incorrectly inflated tires can affect vehicle stability, increase rolling resistance, and cause rapid tire wear and possible permanent damage to the cords of the tire casing.

Remember tire wear and inflation pressure regulations. It is the driver's responsibility to ensure that the tires meet these requirements.

Check the tire pressures weekly, and if necessary, adjust in accordance with pressure requirements on the "tire pressure sign" on the B pillar. This Handbook introduces the correct tire pressure in cold condition, see "Wheel and tire" in General Technical Parameters section.

Pressure should be checked with an accurate Tire Pressure Gauge when the tire is cold instead of decreasing the value under warm condition as the pressure will be higher than normal pressure due to temperature. Always refit the valve caps to prevent dirt entry into the valve mechanism.

A natural pressure loss will occur with time; any unusual pressure loss should be investigated and rectified.

Note: Specified pressure applies to a cold tire, while the pressure of hot tire should be higher.

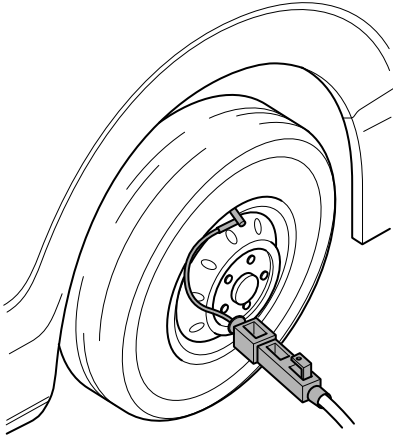

See “Tires” in Starting and Driving section.

Wear indicator

There is wear indicator in tread for all original tires. When the tire has worn down until 1.6 mm of the tread is remaining the wear indicator will appear across the full width of the tread pattern.

A tire should be replaced immediately where any part of the wear indicator becomes visible. However it is in your interest to note that tire safety and performance tends to reduce before the legal limit is reached. For example, badly worn tires will increase the risk of aquaplaning.

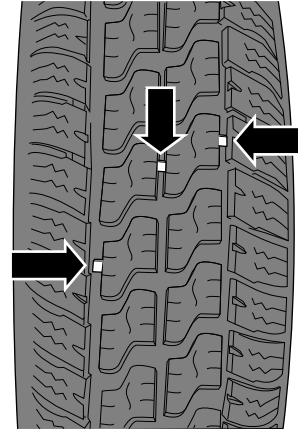

Other maintenance

Vehicle cleaning



For the first driving after washing the vehicle, gently apply the brake pedal several times to ensure all moisture is removed from the brake discs.

Carefully clean tires. Never use a high pressure jet as it may damage tires. If any damage found, replace the tire.

Flushing water on the forepart of the interior car (close to the dashboard area) is prohibited so as not to cause any damage to some related parts.

Never flush the front compartment, battery compartment and surrounding connectors with water.

Careful attention to the following will help to retain the value of your vehicle:

- Clean the vehicle with cold or lukewarm water. Hot water may impair vehicle paint in extremely cold weather.
- No vehicle washing under strong direct sunlight during hot weather.
- Use special vehicle cleaner to remove grease and tar spots on vehicle body and while still wet, wash the paintwork using a soft sponge and generous quantities of water containing car shampoo. Rinse thoroughly and dry off with a chamois leather.

- When cleaning the vehicle with a hose, it is prohibited to spray the water directly to the window, the door, or the brake through the gap of the wheel.
- After cleaning, inspect the paintwork for damage and stone chips; apply touch-up paint if necessary. Use the polishing wax to protect the paintwork from time to time.
- When using high pressure cleaning equipments, the water jet shall be kept moving. Do not directly wash the radiator, door gap, seals, electrical components or components connected to it.

Note: Remove apparently harmless looking but actually aggressive particles from the paintwork immediately - e.g. bird droppings, tree resins, insect remains, tar spots, road salt and industrial fall-out. Otherwise permanent staining or damage will be produced.

Anti-corrosion of underbody

The underbody of your vehicle has been treated with anticorrosion. Check underbody anti-corrosion regularly.

Use a water jet to remove accumulations of caked mud or debris on underbody. Especially in winter, when salt is used on icy and snowy roads.

Seat and trim

Often use vacuum sweeper or soft brush to clean dirt and dust accumulated on fibers. Often use clean cloth to wipe the trim. Use special cleaner to remove general trim dust, staining or spots. Use special cleaner to clean leather parts.

Door seal

To prevent rubber door seals freezing during cold weather, rubber maintenance products or silicone spray shall be used for protection.

Window glass

Often use glass cleaner to clean window glass.

The headlamp lenses are clear plastic. Use good cleaner or neutral detergent rather than abrasive or chemical solvent to wash.

General Technical Parameters

172 Major vehicle dimension parameters

173 Vehicle weight parameters

174 Dynamic performance index

175 Major parameters of drive motor

176 Chassis technical parameters

177 Recommended fluids

178 Wheel and tire

179 Wheel alignment parameters

General Technical Parameters

Major vehicle dimension parameters

Model	SK8C-BA00
Driving type	4X2, Rear-drive
Length of outline dimension, mm	5365
Width of outline dimension, mm	1900
Height of outline dimension, mm	1809
Length of cargo bar board, mm	1485
Width of cargo bar board, mm	1510
Height of cargo bar board, mm	530
Wheel base, mm	3155
Front/Rear suspension, mm	942/1268
Front/Rear wheel track, mm	1580/1580
Minimum turning circle diameter, m	12.6

General Technical Parameters

Vehicle weight parameters

Model	SK8C-BA00
Gross vehicle weight, kg	3300
Curb weight, kg	2300
Axle load (front/rear axle load under gross vehicle weight), kg	1200/2100
Number of seats	5

General Technical Parameters

Dynamic performance index

Item	Parameters
Model	SK8C-BA00
Max. speed, km/h	120
Max. speed, mph	74.6
Maximum gradeability, %	30
Accelerating ability (Accelerating time from 0 to 50 km/h), second	5
Driving range (WLTP condition), km	330

General Technical Parameters

Major parameters of drive motor

Model	TZ220XS612B1
Type	Permanent magnet synchronous motor
Rated speed, r/min	4000
Peak speed, r/min	12000
Rated power, kw	65
Peak power, kw	130
Rated torque, Nm	155
Peak torque, Nm	310

General Technical Parameters

Chassis technical parameters

Item	Parameters
Front suspension	Double wishbone independent suspension
Rear Suspension Structure	Vertical type spring non-independent suspension
Form specifications of steel plate spring	Five leaf spring
Requirements for steel wheel dynamic balance	Both sides of the remaining dynamic imbalance is less than: 10 grams
Dynamic Balance of Aluminum Wheels	Both sides of the remaining dynamic imbalance is less than: 8 grams
Rational range of brake pedal free stroke	within 10 mm
Rational use range of brake friction pair	Friction material thickness is greater than 2 mm

General Technical Parameters

Recommended fluids

Item	Grade	Capacity
Coolant (electric drive system), L	D-35(-35°C)	9.35
Brake fluid, L	Laike 901-4 DOT 4	0.8
Washer fluid, L	Universal low freezing point washer fluid	3.8
Air conditioning refrigerant, g	R1234yf	580±30
Electric drive axle lubricating oil, L	TEMPO GL-5 80W-90	3.5

General Technical Parameters

Wheel and tire

Item	Parameters
Wheel Specification	17x7J
Tire specification	245/65R17 111H
Tire pressure of front wheel(cold condition)	250kPa/2.5bar/36psi
Tire pressure of rear wheel(cold condition)	290kPa/2.9bar/42psi

General Technical Parameters

Wheel alignment parameters

Item		Parameters
Front wheels	Toe-in angle	$0 \pm 0.15^\circ$ Total toe-in $\leq 0.15^\circ$
	Camber angle	$0 \pm 0.5^\circ$ Difference value between left and right $\leq 0.5^\circ$
	Kingpin caster	$3.6 \pm 0.5^\circ$ Difference value between left and right $\leq 0.5^\circ$
Rear wheels	Toe-in angle	$0^\circ \pm 0.25^\circ$
	Camber angle	$0^\circ \pm 0.5^\circ$
	Thrust Angle	$0^\circ \pm 0.25^\circ$