

BMW E39 1996 to 2003 wiring diagrams

Key to circuits

Diagram 1: Information for wiring diagrams.

Diagram 2: Starting, charging, engine cooling fan, horn, heater blower.

Diagram 3: Headlight washer & heated washer jets, front wash/wipe, cigar lighter & charging socket.

Diagram 4: Rear wash/wipe, audio system, Headlight washer & intensive washing system.

Diagram 5: Heated rear window, electric mirrors, electric windows.

Diagram 6: Central locking.

Diagram 7: Stop lights, headlights, side, tail & no plate lights, reversing lights.

Diagram 8: Direction indicators & hazard warning lights, foglights.

Diagram 9: Headlight levelling, interior lighting.

Key to symbols

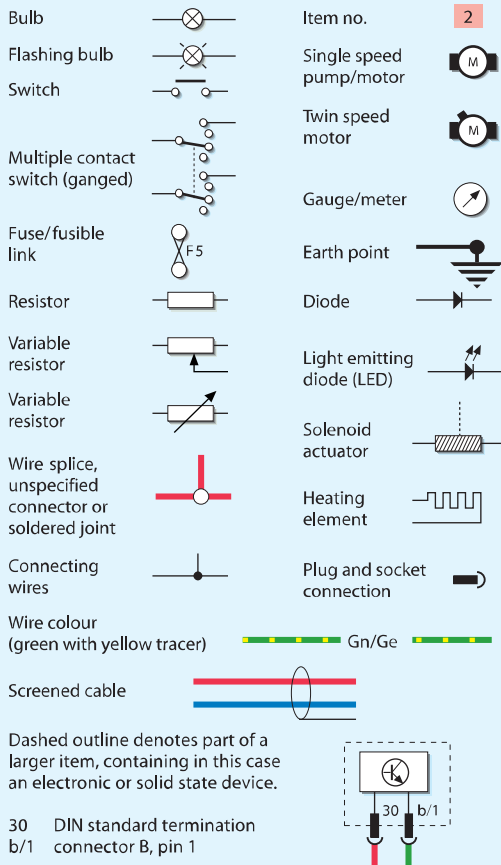

Typical passenger compartment fusebox

Fuse	Rating	Circuit protected
F1	30A	Windscreen wiper
F2	30A	Windscreen washer, headlight washer
F3	15A	Horn
F4	20A	Passenger compartment lighting, luggage compartment lighting, windscreen washer
F5	20A	Sunroof
F6	30A	Electric windows, central locking, electric mirrors
F7	20A	Engine cooling fan
F8	25A	Automatic stability control
F9	15A	Air conditioning, heated washer jets
F10	30A	Passenger seat adjustment
F11	7.5A	Servotronic
F12	5A	Immobilizer
F13	30A	Steering column adjustment, driver's seat adjustment
F14	5A	Engine control
F15	7.5A	Engine control, diagnostic connector
F16	5A	Lighting module
F17	10A	Fuel pump, ABS, automatic stability control
F18	5A	Instrument cluster
F19	-	Not fitted
F20	7.5A	Heated rear window, heater, air conditioning, engine cooling fan, tyre pressure control
F21	5A	Anti-glare interior mirror, driver's seat adjustment, garage door opener, thermal sensor, parking distance control
F22	30A	Engine cooling fan
F23	10A	Heater, independent heater
F24	5A	Instrument cluster, shift gate illumination, tyre pressure control
F25	7.5A	Radio, multi-information display
F26	5A	Windscreen wiper
F27	30A	Central locking, electric windows
F28	30A	Air conditioning, heater blower
F29	30A	Electric mirrors, electric windows, central locking
F30	25A	ABS
F31	10A	ABS automatic stability control, fuel pump,
F32	15A	Heated seats
F33	-	Not fitted
F34	10A	Heated steering wheel
F35	-	Not fitted
F36	-	Not fitted
F37	5A	Immobilizer
F38	5A	Horn, shift gate illumination, diagnostic connector
F39	7.5A	Charging socket, courtesy mirror illumination
F40	5A	Airbag, instrument cluster
F41	5A	Stop light, lighting module, speed control
F42	5A	Airbag
F43	5A	Radio, telephone, on board monitor
F44	5A	Multifunction steering wheel, multi-information display, radio, telephone
F45	7.5A	Roller sun blind
F75	50A	Engine cooling fan
F76	40A	Heater blower

Typical luggage compartment fusebox

Fuse	Rating	Circuit protected
F46	15A	Independent ventilation/heater
F47	15A	Independent heater
F48	5A	Alarm
F49	30A	Air suspension
F50	7.5A	Air suspension
F51	-	Not fitted
F52	30A	Cigar lighter
F53	7.5A	Central locking
F54	15A	Fuel pump
F55	20A	Rear wash/wipe
F56	30A	Rear wash/wipe, CD changer, navigation system, on-board monitor, radio
F57	10A	Telephone
F58	10A	Navigation system, on-board monitor, radio, telephone
F59	-	Not fitted
F60	15A	Electronic damper control
F61	-	Not fitted
F62	-	Not fitted
F63	-	Not fitted
F64	-	Not fitted
F65	-	Not fitted
F66	40A	Heated rear window

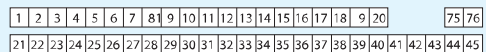

Wire colours

Bl	Blue	Vi	Violet
Br	Brown	Ws	White
Ge	Yellow	Or	Orange
Gr	Grey	Rt	Red
Gn	Green	Sw	Black

Key to items

- | | | | |
|----|----------------------------------|----|-----------------------------|
| 1 | Battery | 11 | Fusible link |
| 2 | Ignition switch | 12 | Horn relay |
| 3 | Starter motor | 13 | LH horn |
| 4 | Alternator | 14 | RH horn |
| 5 | Passenger compartment fusebox | 15 | Horn switch |
| 6 | Engine cooling fan stage 1 relay | 16 | Steering wheel clock spring |
| 7 | Engine cooling fan stage 2 relay | 17 | Heater blower relay |
| 8 | Engine cooling fan stage 3 relay | 18 | Output amplifier |
| 9 | Engine cooling fan motor | 19 | Heater blower motor |
| 10 | Dual temperature switch | | |

Diagram 2

H33054

Typical starting and charging

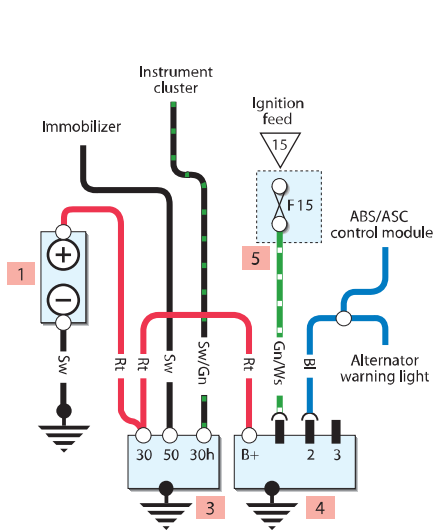

Typical engine cooling fan

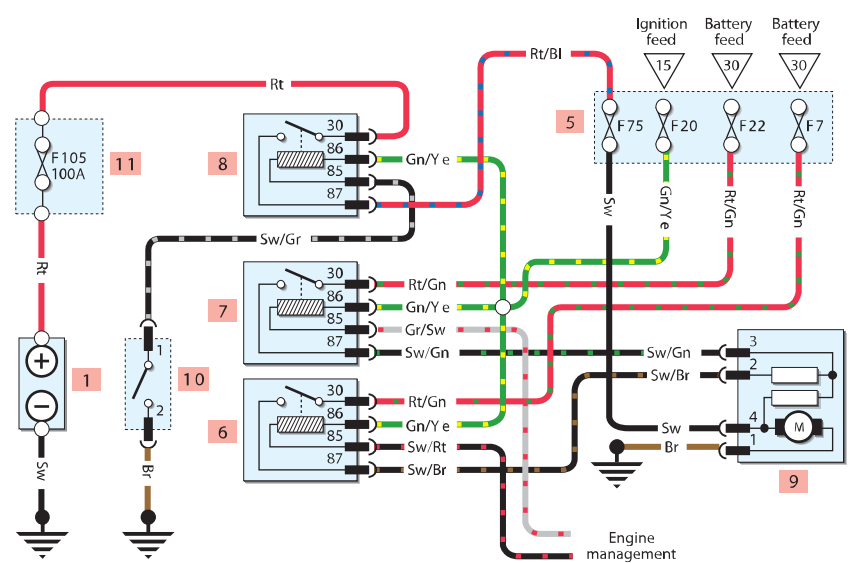

Typical horn

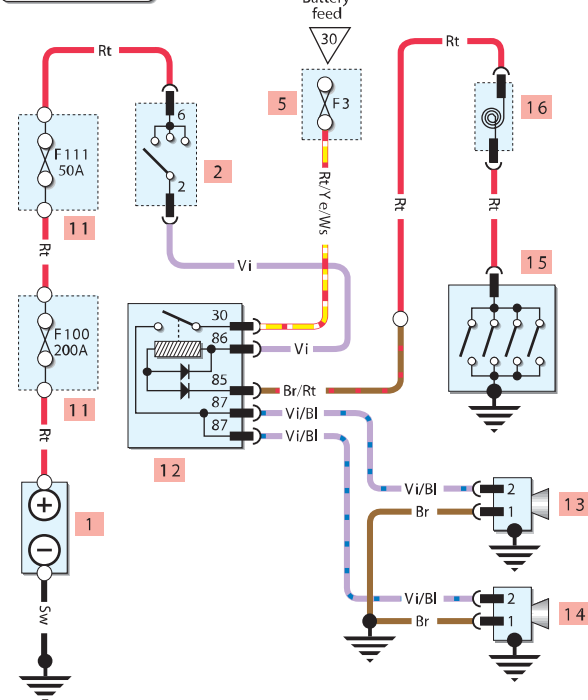

Typical heater blower

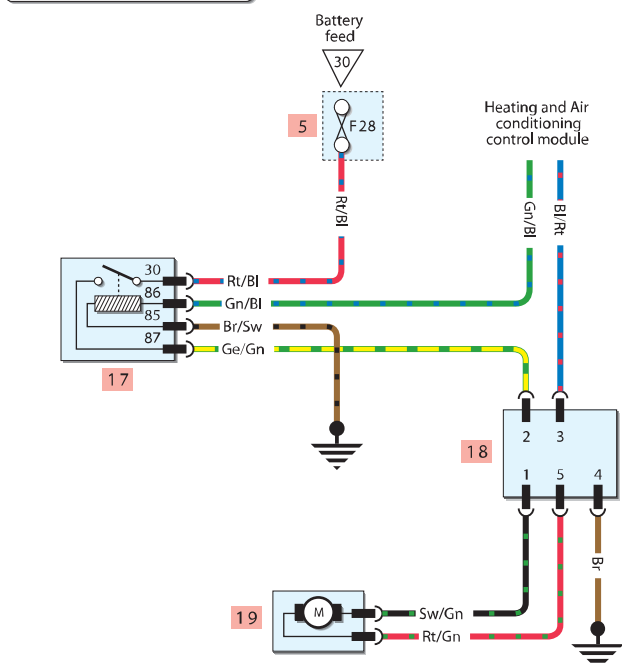

Wire colours

Bl	Blue	Vi	Violet
Br	Brown	Ws	White
Ge	Yellow	Or	Orange
Gr	Grey	Rt	Red
Gn	Green	Sw	Black

Key to items

- | | | | |
|----|-------------------------------|----|------------------------|
| 1 | Battery | 28 | Cigar lighter relay |
| 2 | Ignition switch | 29 | General control module |
| 5 | Passenger compartment fusebox | 30 | Wiper relay 1 |
| 11 | Fusible link | 31 | Wiper relay 2 |
| 22 | Headlight washer module | 32 | Front wiper motor |
| 23 | Headlight washer pump | 33 | Wash/wipe switch |
| 24 | Windscreen washer jet heater | 34 | Washer pump |
| 25 | Luggage compartment fusebox | | |
| 26 | Front cigar lighter | | |
| 27 | Charging socket | | |

H33055

Typical headlight washer & heated washer jets

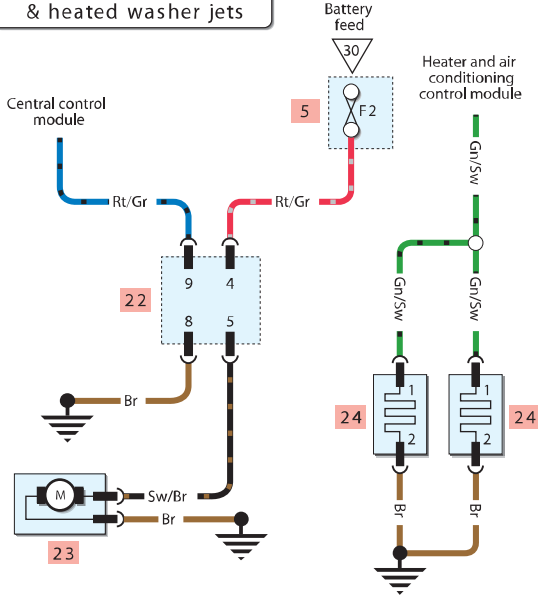

Typical front wash/wipe

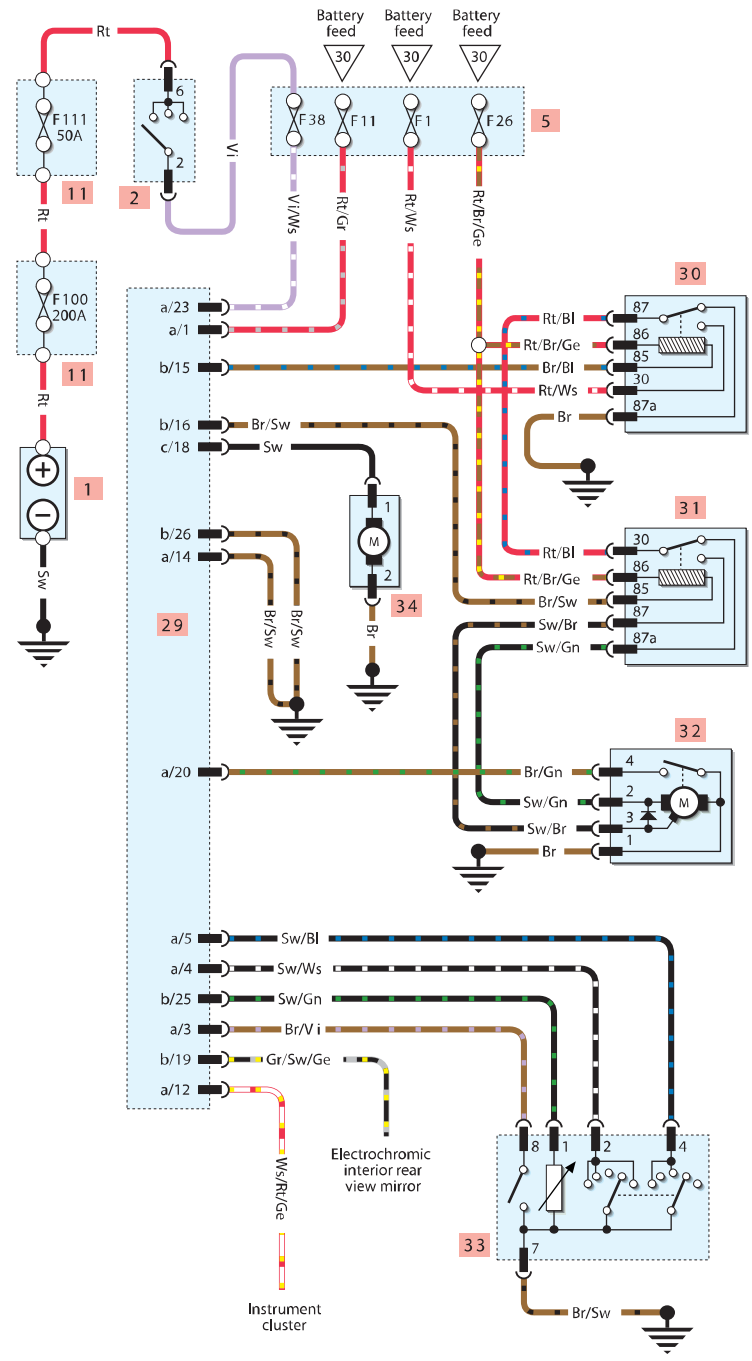

Typical cigar lighter & charging socket

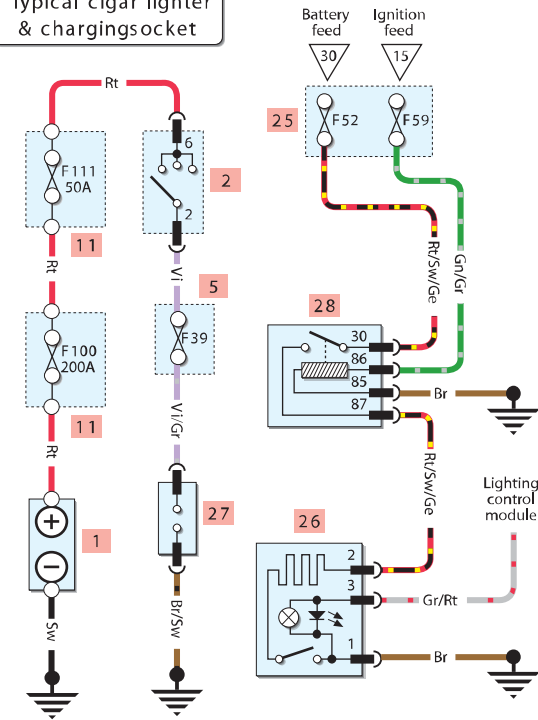

Wire colours

Bl	Blue	Vi	Violet
Br	Brown	Ws	White
Ge	Yellow	Or	Orange
Gr	Grey	Rt	Red
Gn	Green	Sw	Black

Key to items

1	Battery	42	Headlight washer pump	52	RH front speaker
2	Ignition switch	43	Intensive washer pump	53	RH rear speaker
5	Passenger compartment fusebox	44	Unload relay		
11	Fusible link	45	Antenna module		
25	Luggage compartment fusebox	46	CD changer		
33	Wash/wipe switch	47	Audio unit		
38	Rear wash/wipe control unit	48	LH tweeter		
39	Tailgate/boot open switch	49	LH front speaker		
40	Rear washer pump	50	LH rear speaker		
41	Headlight washer module	51	RH front tweeter		

H33056

Typical rear wash/wipe

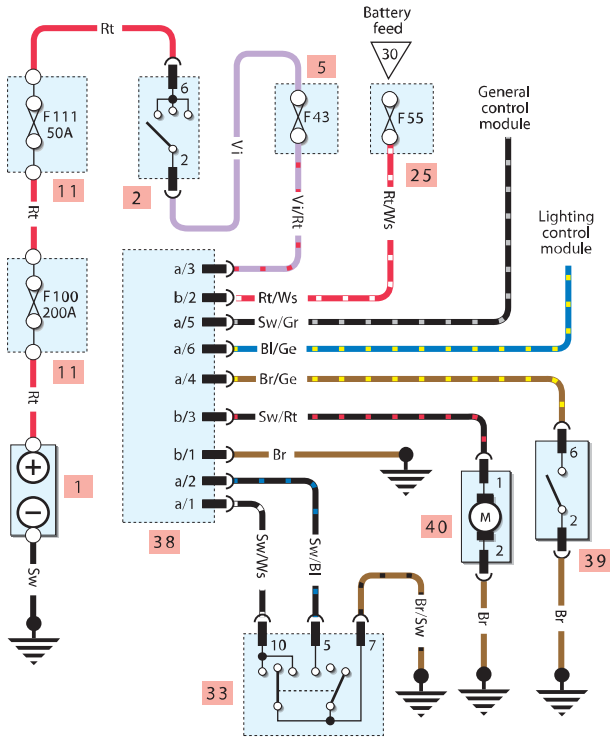

Typical audio system

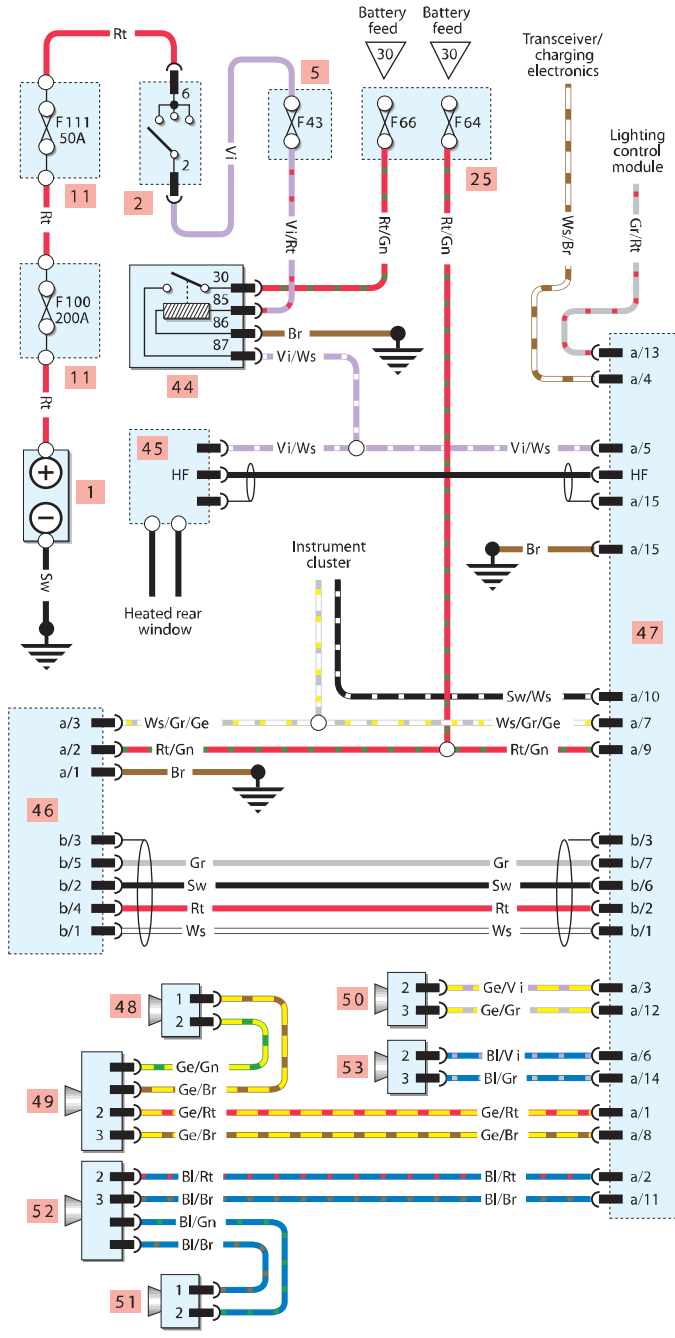

Headlight washer & intensive washing system

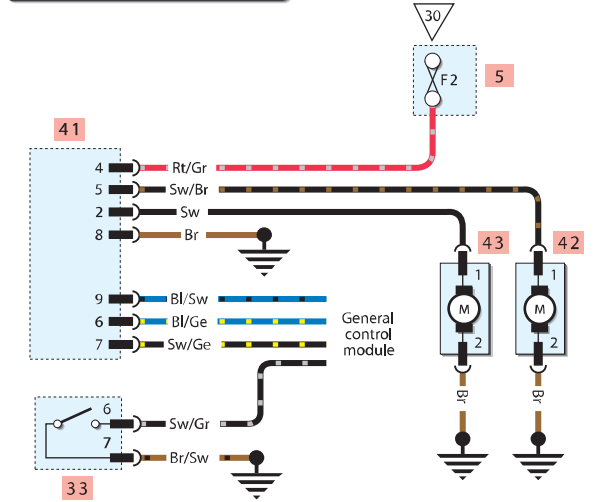

Wire colours

Bl	Blue	Vi	Violet
Br	Brown	Ws	White
Ge	Yellow	Or	Orange
Gr	Grey	Rt	Red
Gn	Green	Sw	Black

Key to items

1	Battery	60	Driver's mirror assembly	69	LH rear window motor
2	Ignition switch	61	Passenger's mirror assembly	70	LH rear jamming switch
5	Passenger compartment fusebox	62	Driver's door module	71	LH rear door window switch
11	Fusible link	63	Driver's window motor	72	RH rear window motor
29	General control module	64	Driver's jamming switch	73	RH rear jamming switch
45	Antenna module	65	Passenger's door module	74	RH rear door window switch
57	Heated rear window relay	66	Passenger's window motor		
58	FM amplifier lockout circuit	67	Passenger's jamming switch		
59	Heated rear window	68	Passenger's door window switch		

Diagram 5

H33057

Typical heated rear window

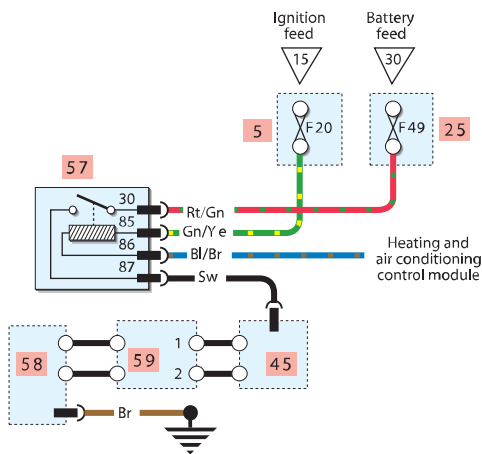

Typical electric mirrors

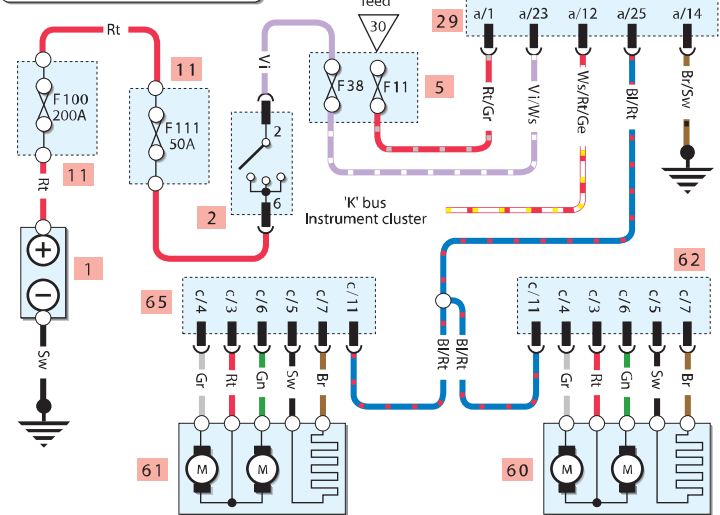

Typical electric windows

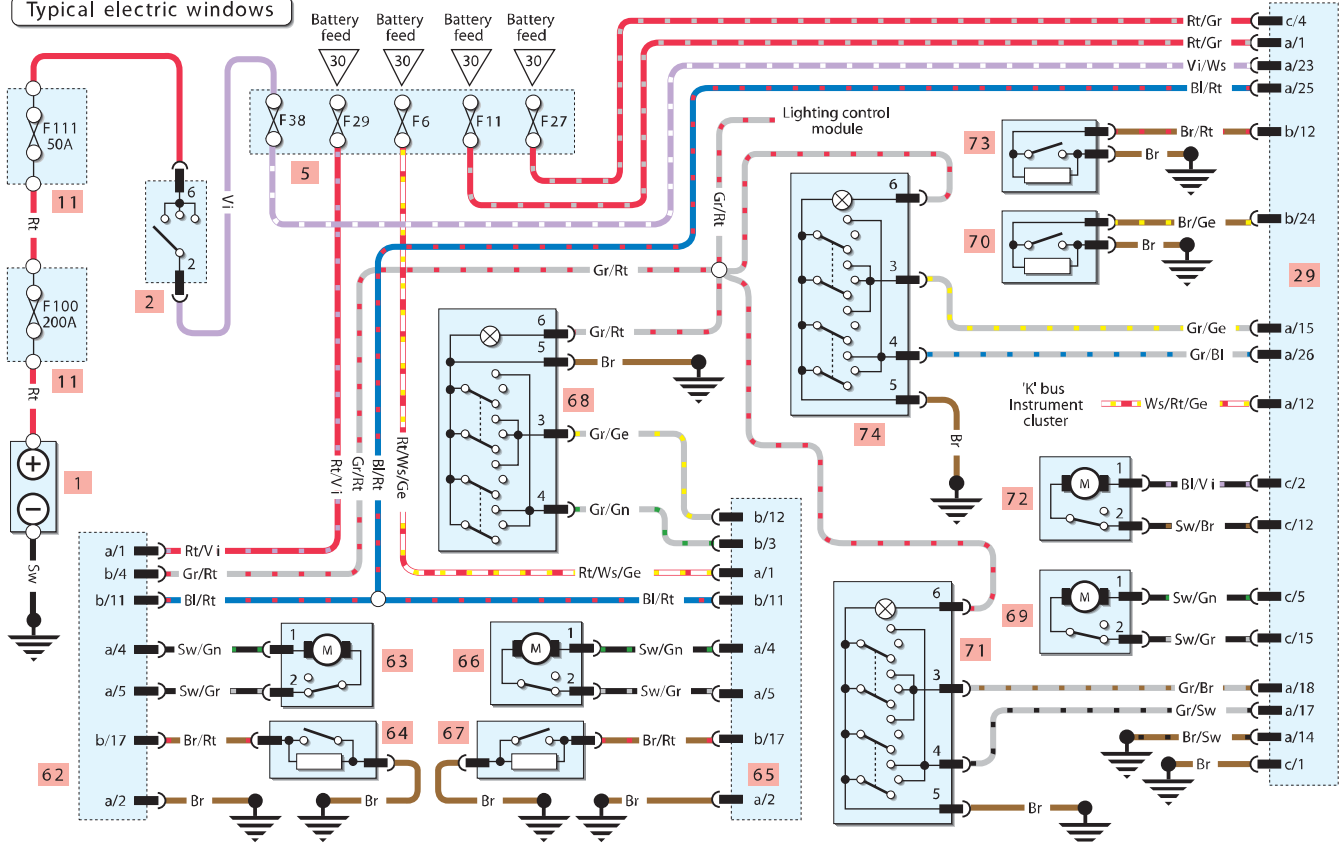

Wire colours

Bl	Blue	Vi	Violet
Br	Brown	Ws	White
Ge	Yellow	Or	Orange
Gr	Grey	Rt	Red
Gn	Green	Sw	Black

Key to items

1	Battery	80	Passenger's door lock switch	90	Passenger's door contact switch
2	Ignition switch	81	Passenger's door lock motor	91	LH rear door contact switch
5	Passenger compartment fusebox	82	Tailgate/boot release switch	92	RH rear door contact switch
11	Fusible link	83	LH rear door lock	93	Tailgate/boot unlocking switch
25	Luggage compartment fusebox	84	RH rear door lock	94	Inertia switch
29	General control module	85	Central locking master switch		
62	Driver's door module	86	Tailgate/boot lock motor		
65	Passenger's door module	87	Fuel filler flap lock motor		
78	Driver's door lock switch	88	Tailgate/boot lock switch		
79	Driver's door lock motor	89	Driver's door contact switch		

Diagram 6

H33058

Typical central locking

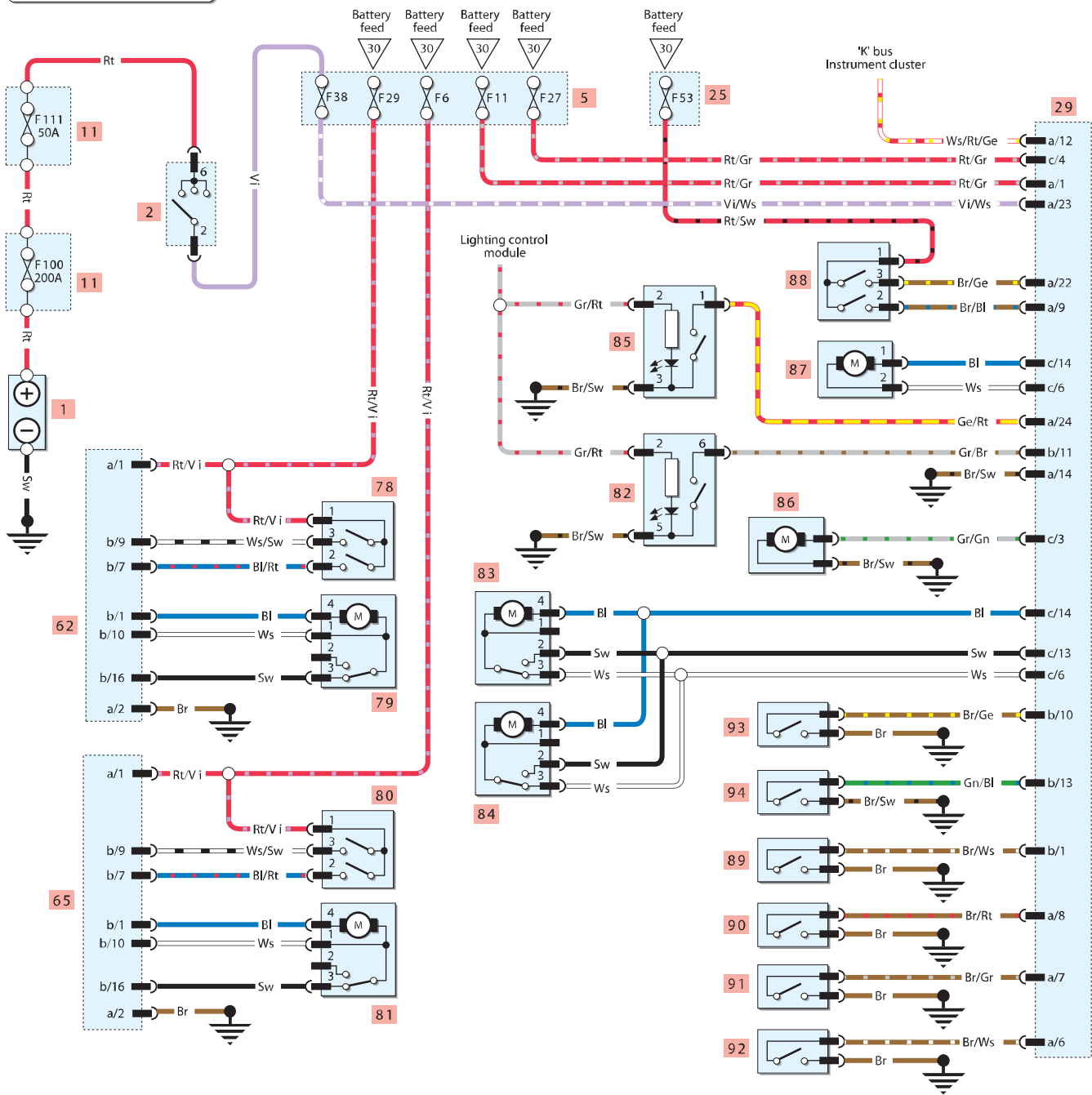

Wire colours

Bl	Blue	Vi	Violet
Br	Brown	Ws	White
Ge	Yellow	Or	Orange
Gr	Grey	Rt	Red
Gn	Green	Sw	Black

Key to items

- 1 Battery
- 2 Ignition switch
- 5 Passenger compartment fusebox
- 11 Fusible link
- 96 Stop light switch
- 97 Lighting control module
- 98 LH stop light
- 99 RH stop light
- 100 High level stop light
- 101 LH reversing light

- 102 RH reversing light
- 103 Reversing light switch
- 104 Light switch
- a = side/headlights
- b = flasher/dip
- 105 RH headlight high beam
- 106 RH headlight low beam
- 107 RH parking light
- 108 LH headlight high beam
- 109 LH headlight high beam

- 110 LH parking light
- 111 RH number plate light
- 112 LH number plate light
- 113 LH tail light
- 114 LH tailgate tail light
- 115 RH tail light
- 116 RH tailgate tail light

Diagram 7

H33059

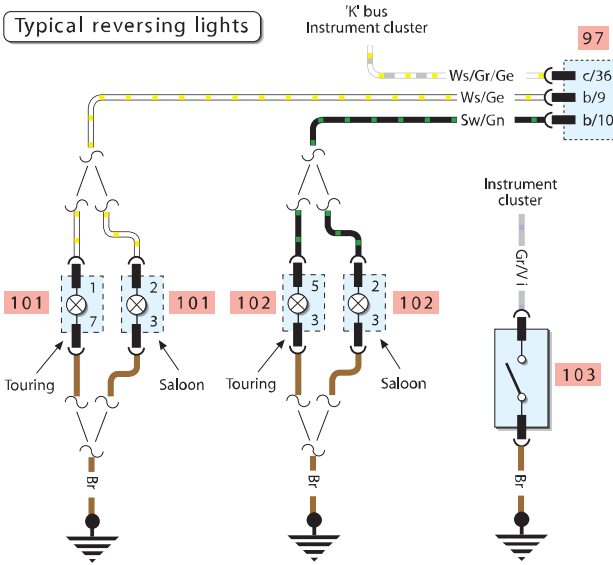
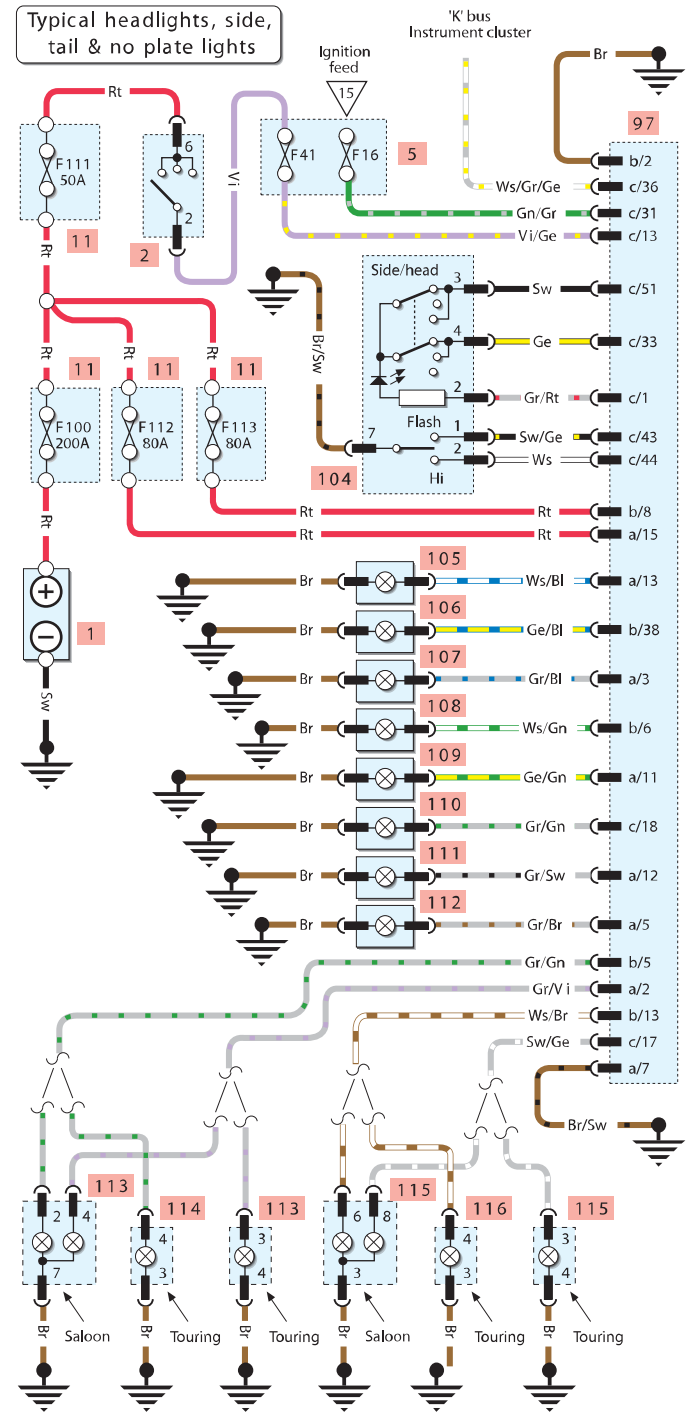
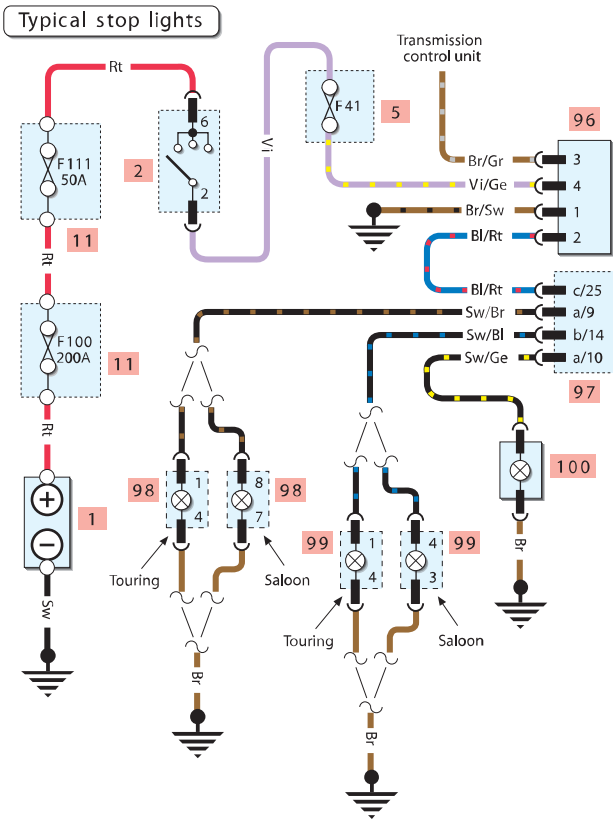

Wire colours

Bl	Blue	Vi	Violet
Br	Brown	Ws	White
Ge	Yellow	Or	Orange
Gr	Grey	Rt	Red
Gn	Green	Sw	Black

Key to items

- 1 Battery
- 2 Ignition switch
- 5 Passenger compartment fusebox
- 11 Fusible link
- 97 Lighting control module
- 104 Light switch
- c = direction indicator switch
- 120 LH front direction indicator
- 121 LH direction indicator side repeater

- 122 LH rear direction indicator
- 123 RH front direction indicator
- 124 RH direction indicator side repeater
- 125 RH rear direction indicator
- 126 Hazard warning switch
- 127 Foglight switch
- 128 LH front foglight
- 129 RH front foglight
- 130 LH rear foglight

- 131 LH tailgate foglight
- 132 RH rear foglight
- 133 RH tailgate foglight

Diagram 8

H33060

Typical direction indicators & hazard warning lights

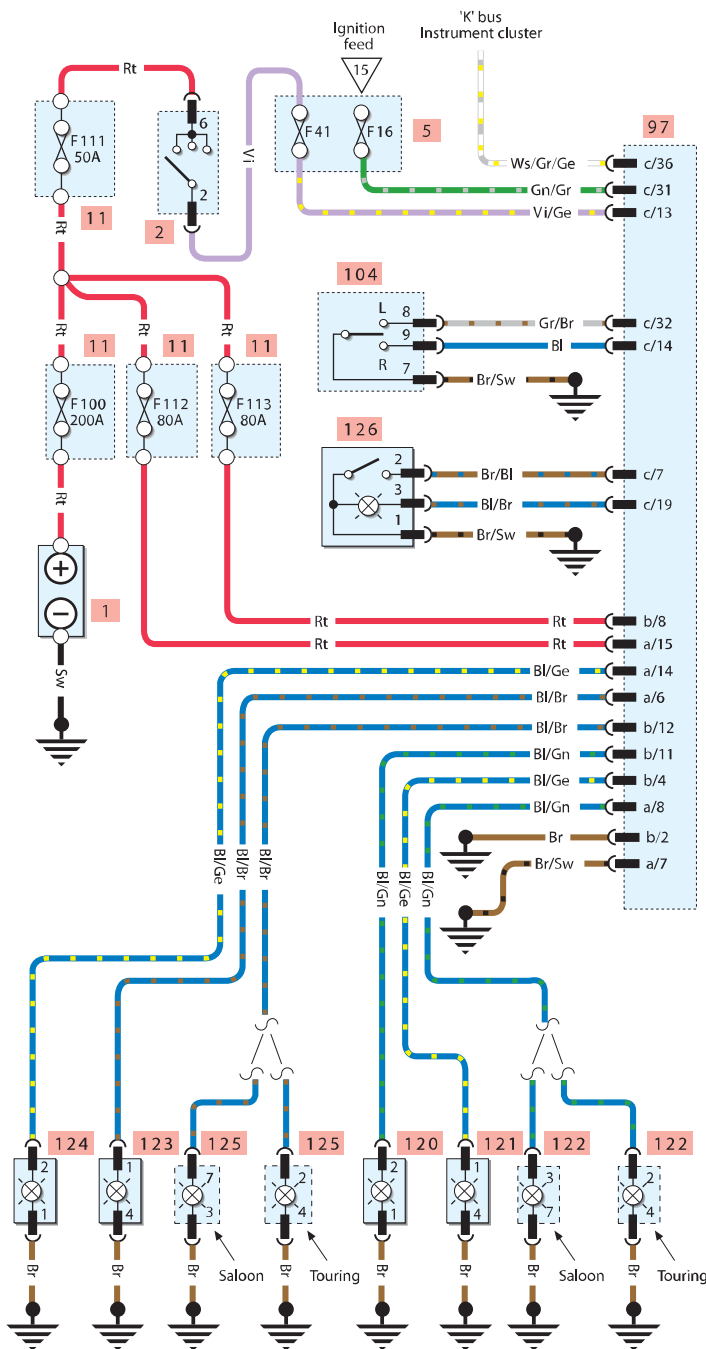

Typical foglights

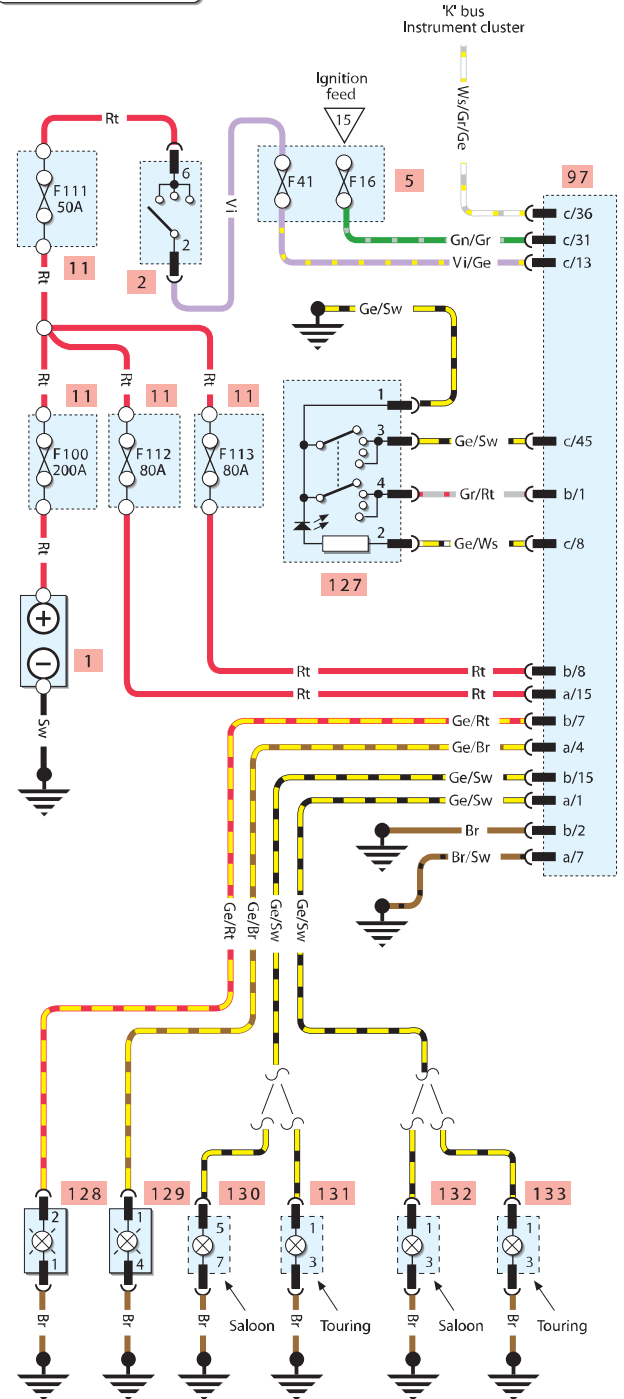

Wire colours

Bl	Blue	Vi	Violet
Br	Brown	Ws	White
Ge	Yellow	Or	Orange
Gr	Grey	Rt	Red
Gn	Green	Sw	Black

Key to items

1	Battery
2	Ignition switch
5	Passenger compartment fusebox
11	Fusible link
29	General control module
86	Tailgate/boot lock motor
89	Driver's door contact switch
90	Passenger's door contact switch
91	LH rear door contact switch
92	RH rear door contact switch

97	Lighting control module
135	Headlight levelling adjuster
136	LH headlight levelling actuator
137	RH headlight levelling actuator
138	Driver's door courtesy light
139	Passenger's door courtesy light
140	LH rear door courtesy light
141	RH rear door courtesy light
142	Driver's vanity mirror light
143	Driver's vanity mirror light switch

144	Passenger's vanity mirror light
145	Passenger's vanity mirror light switch
146	Front interior light
147	Rear interior light (touring)
148	LH rear interior light (saloon)
149	RH rear interior light (saloon)
150	Luggage compartment light
151	Glove box light
152	Glove box light switch

Diagram 9

H33061

